

PROJECT REPORT

TO: **PLANNING COMMISSION**

AGENDA DATE: May 12, 2021

FROM: **PLANNING & DEVELOPMENT SERVICES**

AGENDA TIME 9:00 a.m. / No. 2

PROJECT TYPE: CUP#18-0020 (J.R. Simplot Company) SUPERVISOR DIST #3

LOCATION: 318 W. Harris Road APN: 040-340-043-000

Imperial, CA PARCEL SIZE: 39.96 AC

GENERAL PLAN (existing) Mesquite Lake Specific Plan GENERAL PLAN (proposed) N/A

ZONE (existing) MLI-2 (Mesquite Lake Medium Industrial) ZONE (proposed) N/A

GENERAL PLAN FINDINGS CONSISTENT INCONSISTENT MAY BE/FINDINGS

PLANNING COMMISSION DECISION: HEARING DATE: 05/12/2021

APPROVED DENIED OTHER

PLANNING DIRECTORS DECISION: HEARING DATE: N/A

APPROVED DENIED OTHER

ENVIROMENTAL EVALUATION COMMITTEE DECISION: HEARING DATE: 06/13/2019

INITIAL STUDY: 18-0017

NEGATIVE DECLARATION MITIGATED NEGATIVE DECLARATION EIR

DEPARTMENTAL REPORTS / APPROVALS:

PUBLIC WORKS	<input type="checkbox"/>	NONE	<input checked="" type="checkbox"/>	ATTACHED
AG. COMMISSIONER	<input checked="" type="checkbox"/>	NONE	<input type="checkbox"/>	ATTACHED
APCD	<input type="checkbox"/>	NONE	<input checked="" type="checkbox"/>	ATTACHED
DEH/EHS	<input checked="" type="checkbox"/>	NONE	<input type="checkbox"/>	ATTACHED
FIRE/OES	<input type="checkbox"/>	NONE	<input checked="" type="checkbox"/>	ATTACHED
SHERRIFF'S OFFICE	<input checked="" type="checkbox"/>	NONE	<input type="checkbox"/>	ATTACHED
OTHER	<u>See Attached</u>			

REQUESTED ACTION:

IT IS RECOMMENDED THAT YOU CONDUCT A PUBLIC HEARING AND THAT YOU HEAR ALL THE OPPONENTS AND PROPONENTS OF THE PROPOSED PROJECT. STAFF WOULD THEN RECOMMEND THAT YOU APPROVE CONDITIONAL USE PERMIT #18-0020 BY TAKING THE FOLLOWING ACTIONS:

- 1) ADOPT THE MITIGATED NEGATIVE DECLARATION BY FINDING THAT THE PROPOSED PROJECT, WITH THE PROPOSED MITIGATION MEASURES, WILL NOT HAVE A SIGNIFICANT EFFECT ON THE ENVIRONMENT AS RECOMMENDED AT THE ENVIRONMENTAL EVALUATION COMMITTEE (EEC) MEETING HELD ON THE JUNE 13, 2019;
- 2) MAKE THE DE MINIMUS FINDINGS, AS RECOMMENDED AT THE JUNE 13, 2019 EEC HEARING, THAT THE PROJECT WILL NOT INDIVIDUALLY OR CUMULATIVELY HAVE AN ADVERSE EFFECT ON FISH AND WILDLIFE RESOURCES, AS DEFINED IN SECTION 711.2 OF THE FISH AND GAME CODES;
- 3) ADOPT THE ATTACHED FINDINGS AND RESOLUTION(S), APPROVING CONDITIONAL USE PERMIT #18-0020, SUBJECT TO ALL THE CONDITIONS OF APPROVAL, AND AUTHORIZE THE PLANNING & DEVELOPMENT SERVICES DEPARTMENT DIRECTOR TO EXECUTE THE CUP AGREEMENT.

Planning & Development Services Department

801 MAIN STREET, EL CENTRO, CA, 92243 (442) 265-1736

(Jim Minnick, Director)

S:\AllUsers\APN\040\340\043\CUP #18-0020\PC Pkg\PROJREP - CUP 18-0020.docx

STAFF REPORT
Planning Commission
May 12, 2021
Conditional Use Permit (CUP) #18-0020

Applicant: J.R. Simplot Company

Owner: J.R. Simplot Company
(Fertilizer Terminal Facility)

Project Location:

The proposed project site is located at 318 West Harris Road, Imperial, CA, located within a portion of Tract 141 and 183, Township 14 South, Range 14 East, SBB&M. The 39.96(±)-acre parcel is located on Imperial County Assessor Parcel (APN) 040-340-043-000.

Project Description:

(Proposed Activities): The applicant proposes to relocate its' fertilizer warehouse/terminal, where fertilizer will be received, warehoused and shipped. The project site will receive both solid and liquid fertilizers via Southern Pacific Rail Road, and distribute the fertilizer via trucks. In terms of fertilizer, the facility will utilize segregation for storage purposes. Segregation is a mixture of different kinds of fertilizers in order to obtain a predicted N-P-K¹ chemical composition of solid fertilizer (Miserque, O. and E. Pirard). Therefore, the facility will have the capacity to store 14,075 tons of eight different dry/solid product segregations, and 15,000 tons of four different product segregations of liquid fertilizer. Both the liquid and solid fertilizer will be shipped via truck to recipients.

(Proposed Project Site and Circulation): The primary entrance for the facility is on Harris Road, west of the Southern Pacific Railroad tracks. This primary entrance will receive automobiles for employees and business related traffic. Traffic related activity will include inspection, employees, visitors as well as distribution trucks. Per the County Fire Marshall, a secondary access point will be required for emergency access only. This entrance shall not affect the amount of project traffic counts and will be located just west of the main entrance. Trucks will travel on SR 86 from the distribution to the end users' locations according to the proposed site plan. There will be paved roadway on site for queuing of trucks.

(Operations – Solid Fertilizer): Located at the northern portion of the facility, a proposed rail yard will be used for unloading fertilizer material. At the north/western side of the facility, a 250 TPH drag chain bucket elevator and conveyor will transfer dry fertilizer product from the train cars into Dry Bulk Warehouse #1. The conveyor will receive the product at a shallow rail receiving pit, placed below the working tract, and convey the material to the diverter located within the Dry Bulk Warehouse #1. Once fertilizer reaches

this diverter, there are options. (a) The fertilizer will be diverted via a conveyor belt to be stored within Dry Bulk Warehouse #1; and, (b) the fertilizer will be transported via an additional covered conveyor belt that will run perpendicular from Dry Bulk Warehouse #1 to its destination in Dry Bulk Warehouse #2, where the fertilizer will be stored. Wall separating the different types of fertilizer will be 10' high, made out of large cement blocks, and will be moveable to allow for seasonal and market demand fluctuations. The two warehouse building are identical in size: 100' x 340' with a peak height of 50'. The building will be set up to allow drive through loading. A passageway will be constructed between the buildings to allow a front end loader to travel between the buildings. Prior to operation of the drag chain bucket elevator, applicant will have filed and received permit approval.

(Liquid Fertilizer): Located on the north/eastern side of the facility will be two stations for the unloading of liquid fertilizer from train cars. All unloading stations will have spill containment area construction of curbs and concrete slabs. Five 60-Horse Power (HP) pumps will be located at these unloading stations in order to pump the liquid fertilizer to the Contained Liquid Storage Area, where the liquid fertilizer will be stored in four different storage tanks ranging in sizes. Once liquid fertilizer is ready to be transported to recipients, a 25 HP pump will pump liquid fertilizer to the loading location. This location will have four different outlets connected to the four different storage tanks. The fertilizer will be weighed by a 10' x 80' fully electronic scale located north of the primary access. The product will be weighted via electronic scale upon receipt and before shipping to clients.

(Utilities): The applicant will have an agreement to supply potable water via reservoir tanks. Due to project site location, sewage will be disposed via septic tank and leach bed field. An office and maintenance shop will be provided for employees, along with corresponding amount of parking. Outside lighting will be provided for night operations.

Land Use Analysis:

Under the Land Use Element of the Imperial County General Plan, the project site is designated as "Specific Plan Area" and is zoned "MLI-2 (Mesquite Lake Medium Industrial Zone)" and would be considered consistent with the Imperial County's General Plan, the Mesquite Lake Specific Plan and with the County's Land Use Ordinance requirements with the approval of the Conditional Use Permit.

Surrounding Land Uses, Zoning and General Plan Designations:

The site is bordered by SR 86 and agricultural fields to the north; a concrete ditch, dirt roads and agricultural fields to the east; Baughman Road and agricultural fields to the south; and an IID drain (Trifolium Drain No. 1) and agricultural fields to the west. A total of eight homes are located to the west and south within approximately one-half mile or less from the site.

DIRECTION	CURRENT LAND USE	ZONING	GENERAL PLAN
Project Site	Agriculture	MLI-2	Specific Plan Area
North	Agriculture	MLI-2	Specific Plan Area
South	Agriculture	A-2	Specific Plan Area
East	Agriculture	MLI-2	Specific Plan Area
West	Agriculture	MLI-1	Specific Plan Area

Environmental Determination:

On June 13, 2019, the Environmental Evaluation Committee (EEC) determined that CUP #18-0020 for the proposed relocation of the fertilizer terminal facility located at 302 Danenberg Drive, El Centro, CA. The proposed fertilizer terminal facility to be located at 318 W. Harris Road will receive, warehouse and ship fertilizer, and will not have a significant effect on the environment and recommends a Mitigated Negative Declaration (MND) be prepared. The EEC also made the De Minimus Finding that the project will not individually or cumulatively have an adverse effect on fish and wildlife resources, as defined in Section 711.2 of the Fish and Game Codes.

On June 14, 2019, the public notice for the MND was filed with the Imperial County Clerk-Recorders and was posted and circulated for a 35-day comment period from 06/14/2019 to 07/15/2019.

The project was delayed as item regarding the turn-template was being reviewed by Caltrans. On August 10, 2020, an email was sent from Caltrans stating that they reviewed the template and had no further comments.

Staff Recommendation:

It is recommended that you conduct a public hearing and that you hear all the opponents and proponents of the proposed project. Staff would then recommend that you take the following action:

1. Adopt the Mitigated Negative Declaration by finding that the proposed project with the proposed Mitigation Measures will not have a significant effect on the environment as recommended at the Environmental Evaluation Committee (EEC) meeting held on June 13, 2019;
2. Make the De Minimus Finding as recommended at the June 13, 2019 EEC hearing that the project will not individually or cumulatively have an adverse effect on Fish and Wildlife Resources, as defined in Section 711.2 of the Fish and Game Codes;

3. Adopt the attached Resolution(s) and Supporting Findings, Approving Conditional Use Permit (CUP) #18-0020, subject to all the Conditions and authorize the Planning & Development Services Director to sign the CUP upon receipt from the applicant.

PREPARED BY: David Black, Planner IV
Planning & Development Services



REVIEWED BY: Michael Abraham, AICP, Assistant Director
Planning & Development Services



APPROVED BY: Jim Minnick, Director
Planning & Development Services



ATTACHMENTS:



- A. Location Map
- B. Site Plan
- C. CEQA Resolution
- D. PC Resolution
- E. Conditions of Approval
- F. EEC Package
- G. MND Comment letters

**Attachment A
(Location Map)**

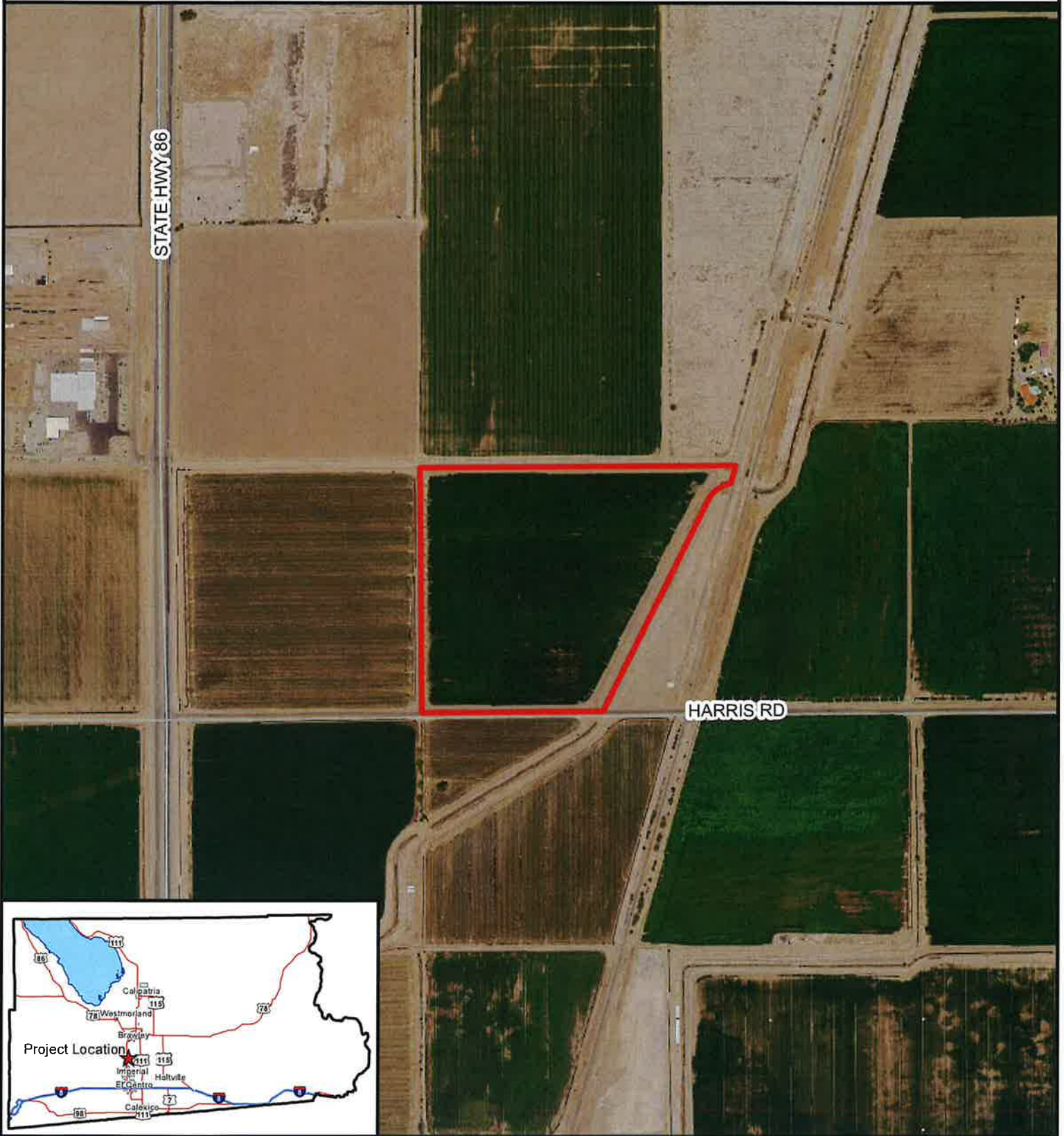
PROJECT LOCATION MAP



J.R. SIMPLOT COMPANY
CUP #18-0020
APN #040-340-043-000

 Parcels selection
 Centerline



Attachment B
(Site Map)

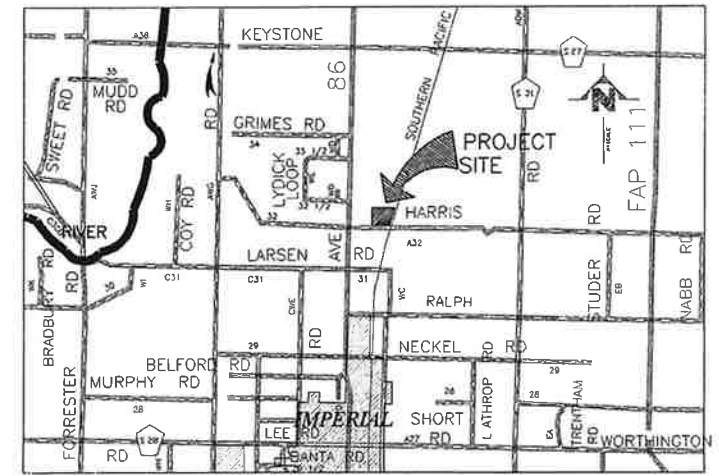
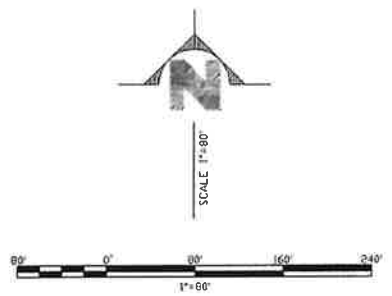
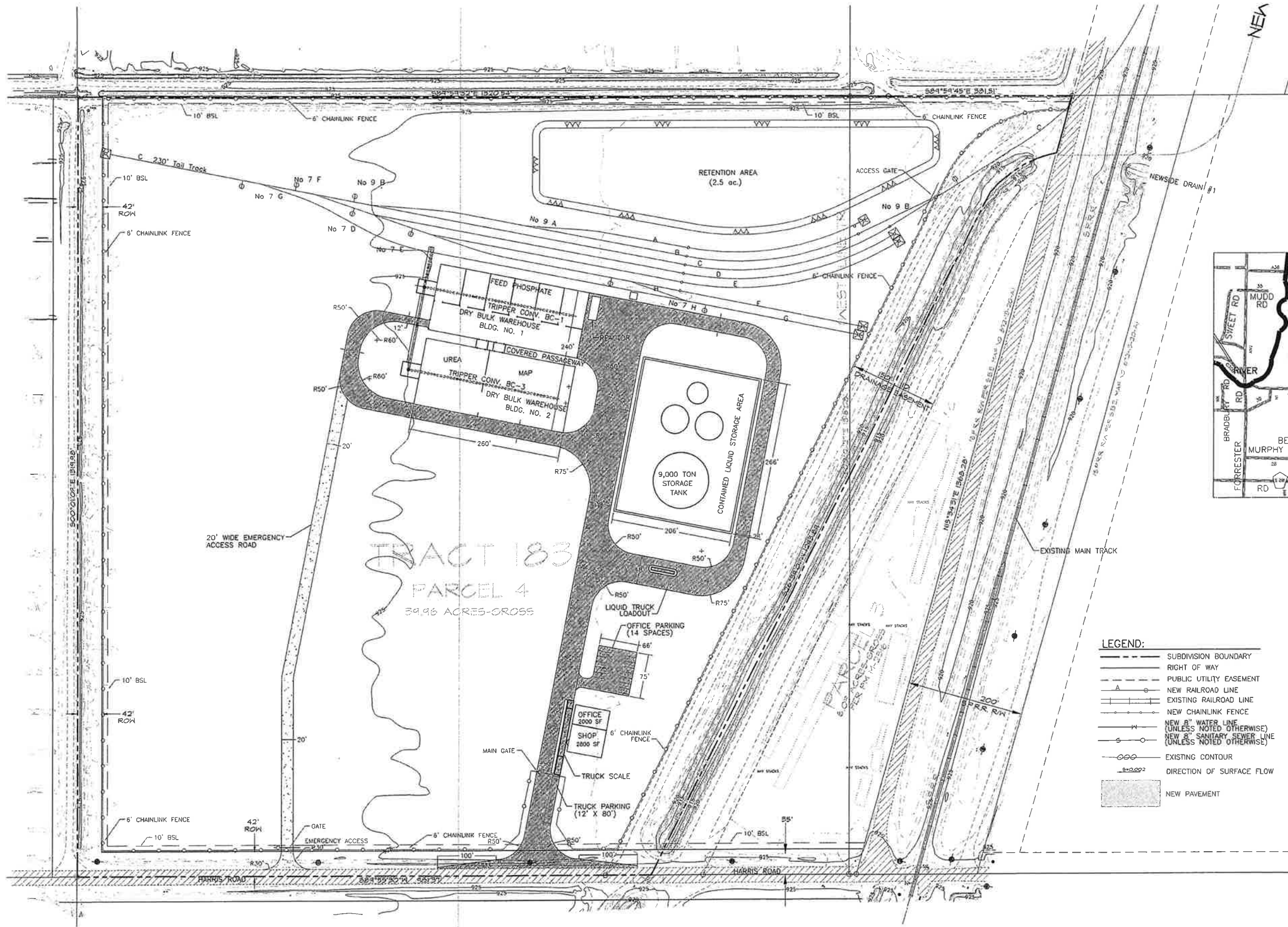

VICINITY MAP

TRACT 183
PARCEL 4
 39.96 ACRES-CROSS

- LEGEND:**
- SUBDIVISION BOUNDARY
 - RIGHT OF WAY
 - PUBLIC UTILITY EASEMENT
 - NEW RAILROAD LINE
 - EXISTING RAILROAD LINE
 - NEW CHAINLINK FENCE
 - NEW 8" WATER LINE (UNLESS NOTED OTHERWISE)
 - NEW 8" SANITARY SEWER LINE (UNLESS NOTED OTHERWISE)
 - EXISTING CONTOUR
 - DIRECTION OF SURFACE FLOW
 - NEW PAVEMENT

ENGINEER/SURVEYOR:
 GORDON O. OLSON, R.C.E., P.L.S.
 DEVELOPMENT DESIGN & ENGINEERING, LLC
 1065 STATE STREET
 EL CENTRO, CALIFORNIA
 TEL (760) 353-8110

OWNER/DEVELOPER
 J.R. SIMPLOT COMPANY
 302 DANENBERG DRIVE
 EL CENTRO, CA 92243
 TEL: (760) 352-8931

GROSS AREA
 39.96 ACRES

CURRENT ZONING
 MLI-2 (LIGHT INDUSTRIAL)

PARKING

OFFICE	1 SPOT/250 SF	2000 SF	= 8
INDUSTRIAL	1 SPOT/500 SF	2800 SF	= 6
TOTAL PARKING PROVIDED			14

A.P.N.
 APN: 040-340-043

LEGAL DESCRIPTION:

THE LAND REFERRED TO IN THIS REPORT IS SITUATED IN THE STATE OF CALIFORNIA, COUNTY OF IMPERIAL AND IS DESCRIBED AS FOLLOWS:
 THOSE PORTIONS OF TRACTS 141 AND 183, TOWNSHIP 14 SOUTH, RANGE 14 EAST, S.B.M., IN AN UNINCORPORATED AREA OF THE COUNTY OF IMPERIAL, STATE OF CALIFORNIA, ACCORDING TO THE OFFICIAL PLAT THEREOF, SHOWN AND DESIGNATED AS PARCELS 3 AND 4 OF PARCEL MAP NO. M-2316 ON FILE IN BOOK 11, PAGE 65 OF PARCEL MAPS IN THE OFFICE OF THE COUNTY RECORDER OF IMPERIAL COUNTY.

No.	DESCRIPTION	BY	DATE	SEAL

FOR PLAN CHECK AND CONSIDERED PRELIMINARY UNTIL APPROVED BY:

 R.C.E. No. _____
 DATE _____ EXP. DATE _____

PREPARED UNDER THE DIRECTION OF:

 CARLOS CORRALES
 55,432
 R.C.E. No. _____
 12/31/08
 EXP. DATE _____

BENCH MARK
 IMPERIAL COUNTY BENCHMARK LOCATED 0.25 MILES NORTH OF THE CROSSING OF HARRIS RD, ABOUT 5 1/2 POLES NORTH AND ACROSS THE TRACK FROM MILE POLE 693, AT THE CROSSING OF NEWSIDE DRAIN IN THE TOP OF THE SOUTHWEST END OF THE SOUTHWEST CONCRETE WINGWALL AND ABOUT 10' LOWER THAN THE TRACK
 (NAVD = 914.60')

Development DESIGN & ENGINEERING

planning - civil engineering - land surveying - project management
 1160 353-8110 1065 State Street info@dde-inc.net
 (760) 352-6406 El Centro, CA 92243 www.dde-inc.net

SITE PLAN
FERTILIZER TERMINAL RELOCATION
COUNTY OF IMPERIAL
TRACT 183, T.14 S., R.14 E., S.B.M.

IMPERIAL COUNTY, CALIFORNIA
 J.R. SIMPLOT

DATE: 1-30-08
 SHEET: 1 OF 1

08/07/04(Engineering)Dwg07064SP2.dwg, 1/30/2008 2:53:07 PM, A.O.

**Attachment C
(CEQA Resolution)**

RESOLUTION NO. _____

A RESOLUTION OF THE PLANNING COMMISSION OF THE COUNTY OF IMPERIAL, CALIFORNIA, ADOPTING THE “MITIGATED NEGATIVE DECLARATION” FOR CONDITIONAL USE PERMIT #18-0020

WHEREAS, on May 31, 2019, a Public Notice was mailed to the surrounding property owners advising them of the Environmental Evaluation Committee hearing scheduled for June 13, 2019;

WHEREAS, a Mitigated Negative Declaration, CEQA findings has been prepared in accordance with the requirements of the California Environmental Quality Act, State Guidelines, and the County's "Rules and Regulations to Implement CEQA, as Amended";

WHEREAS, the Environmental Evaluation Committee recommended to the Planning Commission of the County of Imperial to adopt the Mitigated Negative Declaration & the Mitigation Monitoring and Reporting Program (MM&RP) for Conditional Use Permit #18-0020;

WHEREAS, the Mitigated Negative Declaration was circulated for 35 days from June 14, 2019 to July 15, 2019 (**SCH #2019069064**);

WHEREAS, the Planning Commission of the County of Imperial has been designated with the responsibility of adoptions and certifications;

WHEREAS, public notice of said application has been given, and the Planning Commission has considered evidence presented by the Imperial County Planning & Development Services Department and other comments by interested parties at a public hearing held with respect to this item on May 12, 2021.

NOW, THEREFORE, the Planning Commission of the County of Imperial **DOES HEREBY RESOLVE** as follows:

The Planning Commission has reviewed the attached Mitigated Negative Declaration (MND) & Mitigation Monitoring and Reporting Program (MM&RP) prior to approval of Conditional Use Permit #18-0020. The Planning Commission finds and determines that the MND is adequate and prepared in accordance with the requirements of the California Environmental Quality Act (CEQA) which analyzes the project's environmental effects, based upon the following findings and determinations:

1. That the recital set forth herein are true, correct, and valid; and,
2. That the Planning Commission has reviewed the attached Mitigation Negative Declaration (MND) for Conditional Use Permit #18-0020 and considered the information contained in the MND together with all comments received during the public review period and prior to approving the Conditional Use Permit; and,

3. That the project and associated Mitigated Negative Declaration will not individually or cumulatively have an adverse effect on fish and wildlife resources, as defined in Section 711.2 of the Fish and Game Code; and
4. That the review and approval of Mitigation Negative Declaration (MND) Findings reflects the Planning Commission independent judgment and analysis.

NOW, THEREFORE, based on the above findings, the Planning Commission **DOES HEREBY ADOPT** the Mitigated Negative Declaration (MND) for Conditional Use Permit #18-0020.

**Rudy Schaffner, Chairperson
Imperial County Planning Commission**

I hereby certified that the preceding Resolution was taken by the Planning Commission at a meeting conducted on May 12, 2021 by the following vote:

AYES:

NOES:

ABSENT:

ABSTAIN:

ATTEST:

Jim Minnick,
Secretary to the Planning Commission

**Attachment D
(PC Resolution)**

RESOLUTION NO. _____

A RESOLUTION OF THE PLANNING COMMISSION OF THE COUNTY OF IMPERIAL, CALIFORNIA APPROVING CONDITIONAL USE PERMIT #18-0020 FOR J.R. SIMPLOT COMPANY

WHEREAS, J.R. Simplot Company, Inc. has submitted an application for Conditional Use Permit #18-0020 proposing the relocation of the fertilizer terminal facility located at 302 Dannenberg Drive, El Centro to 318 W. Harris Road, Imperial. The proposed terminal facility will receive, warehouse and ship fertilizer;

WHEREAS, a Mitigation Negative Declaration and CEQA Findings have been prepared in accordance with the requirements of the California Environmental Quality Act, the State Guidelines, and the County's "Rules and Regulations to Implement CEQA, as Amended";

WHEREAS, the Planning Commission of the County of Imperial has been delegated with the responsibility of adoptions and certifications;

WHEREAS, public notice of said application has been given, and the Planning Commission has considered evidence presented by the Imperial County Planning & Development Services Department and other interested parties at a public hearing held with respect to this item on May 12, 2021;

WHEREAS, on June 13, 2019 the Environmental Evaluation Committee heard the proposed project and recommended the Planning Commission adopt the Mitigated Negative Declaration;

NOW, THEREFORE, the Planning Commission of the County of Imperial **DOES HEREBY RESOLVE** as follows:

SECTION 1. The Planning Commission has considered Conditional Use Permit #18-0020 and Conditions of Approval prior to approval; the Planning Commission finds and determines that the Conditional Use Permit and Conditions of Approval are adequate and prepared in accordance with the requirements of the Imperial County General Plan and Land Use Ordinance and the California Environmental Quality Act (CEQA) which analyses environmental effects, based upon the following findings and determinations.

SECTION 2. That in accordance with State Planning and Zoning Law and the County of Imperial Land Use Ordinance, the following findings for the approval of Conditional Use Permit #18-0020 have been made:

- A. The proposed use is consistent with the goals and policies of the adopted County General Plan.**

The County's General Plan Land Use Map designates the project site as "Specific Plan Area" being Mesquite Lake Specific Plan," and since the

proposed use is an agricultural land use allowed by zoning, project is consistent with the Mesquite Lake Specific Plan and the Imperial County General Plan.

B. The proposed use is consistent with the purpose of the zone or sub-zone which the use will be used.

The proposed application is for a fertilizer terminal facility. Under the Imperial County Land Use Ordinance, the project site is zoned MLI-2 (Mesquite Lake Medium Industrial), per zoning map #14-A (§92514.00), which allows for "Heavy Wholesale, Storage and Distribution" with an approved conditional use permit (CUP), pursuant to §90508.02 (mm); therefore, if the proposed CUP is approved, the proposed project will be consistent with the Imperial County Land Use Ordinance and the zone within which the use will be located.

C. The proposed use is listed as a use within the zone or sub-zone or is found to be similar to a listed conditional use according to the procedures of Section 90203.10.

The proposed use is listed as an allowed use with an approved conditional use permit (CUP) in the MLI-2 zone (Section 90508.02).

D. The proposed use meets the minimum requirements of Title 9 applicable to the use and complies with all applicable laws, ordinances and regulations of the County of Imperial and the State of California.

The conditions of approval will ensure that CUP #18-0020 meets all the applicable minimum requirements of Title 9, and it complies with CEQA and other state laws.

E. The proposed use will not be detrimental to the health, safety, and welfare of the public or to the property and residents in the vicinity.

The proposed CUP (#18-0020), with the proposed mitigation measures and conditions of approval, will not be detrimental to the health, safety, and welfare of the public or to the property and residents in the vicinity.

F. The proposed use does not violate any other law or ordinance.

CUP #18-0020 for a fertilizer terminal facility will not violate any other law or ordinance because it is consistent with Title 9, the Land Use Ordinance of the County of Imperial, and CEQA. Additionally, the use will be subject to the conditions imposed through the CUP process, which will enforce any applicable Federal, State and Local regulations.

G. The proposed use is not granting a special privilege.

The proposed uses are not granting any special privilege because the proposed uses as described in the Staff Report and Conditions of Approve

(CUP 18-0020) are allowed with a Planning Commission approved conditional use permit in the (Mesquite Lake Specific Plan) MLI-2 Medium Industrial Zone.

NOW, THEREFORE, based on the above findings, the Imperial County Planning Commission **DOES HEREBY APPROVE** Conditional Use Permit #18-0020, subject to the Conditions of Approval.

Rudy Schaffner, Chairperson
Imperial County Planning Commission

I hereby certify that the preceding resolution was taken by the Imperial County Planning Commission at a meeting conducted on May 12, 2021 by the following vote:

AYES:

NOES:

ABSENT:

ABSTAIN:

ATTEST:

Jim Minnick
Director of Planning & Development Services
Secretary to the Planning Commission

(Conditions of Approval)

When Recorded Return to:

Imperial County Planning & Development
Services Department
801 Main Street
El Centro California 92243

AGREEMENT FOR CONDITIONAL USE PERMIT CUP#18-0020

(J.R. Simplot Fertilizer Terminal)
Planning Commission Approval 05/12/2021
(Assessor's Parcel Number 040-340-043-000)
(Approved by Planning Commission on May 12, 2021)

This Agreement is made and entered into on May____ 2021, by and between J.R. Simplot Inc., hereinafter referred to as "Permittee", and the COUNTY OF IMPERIAL, a political subdivision of the State of California, hereinafter referred to as "COUNTY".

WHEREAS, Permittee is the owner, lessee or successor "in" interest in certain land in Imperial County identified as Parcel 4 of Parcel Map 2316, Tracts 141 and 183, Township 14 South & Township 15 South, Range 14 East, SBB&M also known as Assessor's Parcel Number 040-340-043-000; and,

WHEREAS, Permittee has applied to the "County" for permission to construct and operate a fertilizer distribution and warehouse business; and,

WHEREAS, Permittee will not operate any type of use other than specified herein; and,

WHEREAS, County, after a review of the project, after preparation and circulation of the Mitigated Negative Declaration, after a noticed public hearing

before the Planning Commission, dated May 12, 2021, agreed to issue Conditional Use Permit #18-0020, subject to all of the following conditions:

NOW THEREFORE, the County issues CUP #18-0020 subject to all of the following conditions.

GENERAL CONDITIONS:

The "GENERAL CONDITIONS" are shown by the letter "G". These conditions are conditions that are either routinely and commonly included in all Conditional Use Permits as "standardized conditions" and/or are conditions that the Imperial County Planning Commission has established as a requirement on all CUP's for consistent application and enforcement. The Permittee is hereby advised that the General Conditions are as applicable as the SITE SPECIFIC conditions.

G-1 GENERAL LAW

The Permittee shall comply with all local, state and/or federal laws, rules, regulations, ordinances, and/or standards as they may pertain to the Project whether specified herein or not.

G-2 COSTS

The Permittee shall pay any and all amounts as determined by the County to defray all costs for the review of reports, field inspections, enforcement, monitoring, or other activities related to compliance with this permit, County Ordinances, and/or other applicable regulations.

G-3 PERMITS/LICENSES

The Permittee shall obtain any and all local, state and/or federal permits, licenses, and/or other approvals for the construction and/or operation of the Project. This shall include, but not be limited to, local requirements by the Imperial County EHS/Health Department, Planning and Development Services Department, Imperial County Air Pollution Control District (ICAPCD), Imperial Irrigation District (IID), Imperial County Public Works Department, Imperial County Sheriff/Coroner's office, Imperial County Fire Protection/Office of Emergency Services; among others. Permittee shall likewise comply with all such permit requirements. Additionally, Permittee shall submit a copy of such additional permits and/or licenses to the Planning and Development Services Department within thirty (30) days of receipt, including amendments or alternatives thereto, when requested.

G-4 RECORDATION

This permit shall **not be effective** until it is recorded at the Imperial County Recorder's Office, and payment of the recordation fee shall be the responsibility of the Permittee.

If the Permittee fails to pay the recordation fee within six (6) months from the date of approval, and/or this permit is not recorded within 180 days from the date of approval, this permit shall be deemed null and void, without notice having to be provided to Permittee. Permittee may request a written extension by filing such a request with the Planning Director at least sixty (60) days prior to the original 180-day expiration. The Director may approve an extension for a period not to exceed 180 days. An extension may not be granted if the request for an extension is filed after the expiration date.

G-5 COMPLIANCE/REVOCAION

Upon the determination by the Planning and Development Services Department, (if necessary upon consultation with other Departments or Agency(ies) that the project is or may not be in full compliance with any one or all of the conditions of this Conditional Use Permit, or upon the finding that the project is creating a nuisance as defined by law, the PERMIT and the noted violation(s) shall be brought immediately to the attention of the appropriate enforcement agency or to the Planning Commission for hearing to consider appropriate response including but not limited to the revocation of the CUP or to consider possible amendments to the CUP. The hearing before the Planning Commission shall be held upon due notice having been provided to the Permittee and to the public in accordance with established ordinance/policy.

G-6 PROVISION TO RUN WITH LAND

The provisions of this project are to run with the land/project and shall bind the current and future owner(s) successor(s) of interest, assignee(s) and/or transferee(s) of said project. Permittee shall not without prior notification to the Planning and Development Services Department assign, sell, or transfer, or grant control of this Permit or any right or privilege herein. The Permittee shall provide a written notice a minimum of sixty (60) calendar days prior to such proposed transfer becoming effective.

G-7 RIGHT OF ENTRY

The County reserves the right to enter the premises to make the appropriate inspection(s) at any time, announced or unannounced, in order to make appropriate inspection(s) and to determine if the condition(s) of this permit are

complied with. Access to authorized enforcement agency personnel shall not be denied.

G-8 TIME LIMIT

Unless otherwise specified within the project specific conditions this project shall be limited to a maximum of (3) three years from the recordation date of the CUP. The CUP may be extended for successive three (3) years by the Planning Director upon a finding by the Planning & Development Services Department that the project is in full and complete compliance with all conditions of the CUP and any applicable land use regulation(s) of the County of Imperial. Unless specified otherwise herein, no conditional use permit shall be extended for more than four (4) consecutive periods. If an extension is necessary or requested beyond fifteen (15) years, the Permittee shall file a written request with the Planning Director for a hearing before the Planning Commission. Such request shall include the appropriate extension fee. An extension shall not be granted if the project is in violation of any one or all of the conditions or if there is a history of non-compliance with the project conditions. This time limit is contingent upon initial and continued compliance with Specific Condition S-18 "State & Local Cannabis Activities License/Permits.

G-9 DEFINITIONS

In the event of a dispute the meaning(s) or the intent of any word(s), phrase(s), and/or conditions or sections herein shall be determined by the Planning Commission of the County of Imperial. Their determination shall be final unless an appeal is made to the Board of Supervisors within the required time. In this permit, the term Permittee may also apply to any other facility user whether specified by name herein or not. To the extent that this site may be used by more than one service provider other than the applicant (Permittee), all of the conditions of this permit shall be equally applicable to the other "user(s)" as if they were the "Permittee".

G-10 SPECIFICITY

The issuance of this permit does not authorize the Permittee to construct or operate this project in violation of any state, federal, local law nor beyond the specified boundaries of the project as shown on the application/project description, nor shall this permit allow any accessory or ancillary use not specified herein. This permit does not provide any prescriptive right or use to the Permittee for future addition and/or modification to this project. The site specific use authorized by this permit is listed under the SITE SPECIFIC ("S") conditions, and only the use or uses listed shall be deemed as approved by this permit.

G-11 HEALTH HAZARD

If the County Health Officer determines that a significant health hazard exists to the public, the County Health Officer may require appropriate measures and the Permittee shall implement such measures to mitigate the health hazard. If the hazard to the public is determined to be imminent, such measures may be imposed immediately and may include temporary suspension of the subject operations. However, within forty-five (45) days of any such suspension of operations, the measures imposed by the County Health Officer must be submitted to the Planning Commission for review and approval. Nothing shall prohibit Permittee from requesting a special Planning Commission meeting provided Permittee bears all costs.

G-12 REPORT(S)

Permittee shall file an annual report with the Planning and Development Services Department to show that Permittee is in full compliance with this Conditional Use Permit. The report shall be filed at least fifteen (15) days prior to the anniversary (recordation date) of this permit. It shall be the responsibility of the Permittee to provide all reports and to include the information about other users. The County may request information at any time from the Permittee or other users if applicable; however, it shall be the responsibility of the Permittee to assure that the County receives such information in a timely manner.

G-13 RESPONSIBLE AGENT

Permittee shall maintain on file with the Planning and Development Services Department the name and phone number of the responsible agent for the site. A back-up name shall also be provided, and a phone number for twenty-four (24) hour emergency contact shall also be on file. If there are other users, the same information (as applicable) required from the Permittee shall also be made available to the County from such other users.

G-14 INDEMNIFICATION

As a condition of this Permit, Permittee agrees to defend, indemnify, hold harmless, and release the County, its agents, officers, attorneys, and employees from any claim, action, or proceeding brought against any of them, the purpose of which is to attack, set aside, void, or annul the Permit or adoption of the environmental document which accompanies it. This indemnification obligation shall include, but not be limited to, damages, costs, expenses, attorney's fees, or expert witness fees that may be asserted by any person or entity, including the Permittee, arising out of or in connection with the approval of this Permit, whether or not there is concurrent, passive or active negligence on the part of the County, its agents, officers, attorneys, or employees.

G-15 CHANGE OF OWNER/OPERATOR

In the event the ownership of the site or the facilities or the operation of the site transfers from the current Permittee to a new successor Permittee, the successor Permittee shall be bound by all terms and conditions of this permit as if said successor was the original Permittee. Current Permittee shall inform the County Planning and Development Services Department in writing at least sixty (60) calendar days prior to any such transfer. Failure of a notice of change of ownership or change of operator shall be grounds for the immediate revocation of the CUP. In the event of a change, the new Owner/Operator shall file with the Planning and Development Services Department via Certified Mail, a letter stating that they are fully aware of all conditions and acknowledge that they will adhere to all conditions and/or regulations. If this permit or any subservient or associated permit requires financial surety, the transfer of this permit shall not be effective until the new Permittee has the requisite surety on file. Furthermore, the existing surety shall not be released until a replacement surety is accepted by County Counsel's office.

G-16 MINOR AMENDMENTS

The Planning Director may approve minor changes or administrative extensions, as requested in writing by the Permittee, provided it does not result in additional environmental impacts and/or are generally procedural or technical and/or which may be necessary to comply with other government permit compliance requirements.

G-17 CONDITION PRIORITY

This project shall be constructed and operated as described in the Conditional Use Permit application, the Environmental Assessment, the project description, and as specified in these conditions. Where a conflict occurs, the Conditional Use Permit conditions shall govern and take precedence.

G-18 SEVERABILITY

Should any condition(s) of this permit be determined by a Court or other agency with proper jurisdiction to be invalid for any reason, such determination shall not invalidate the remaining provision(s) of this permit.

G-19 WATER AND SEWER

Permittee shall provide water and sewer to Federal, State and County standards. Water and sewer systems shall be approved by the Environmental Health Services and the Planning and Development Services Department.

G-20 COMMENCEMENT OF WORK

No commencement of work until all conditions pursuant to the CUP has been satisfied. Evidence that all conditions pursuant to the CUP have been satisfied shall be provided to the Planning Director prior to commencement.

G-21 FIRE PROTECTION

Permittee shall provide an adequate fire protection system and accessibility to the site in accordance with the National Fire Protection Act (NFPA), 2013 California Fire Code, and County Fire Department standards. This shall include all requirements by the Imperial County Fire Department regarding fire protection water storage and access roads. Additionally Permittee shall provide to Imperial County Fire Department a plot plan, drawn to scale indicating the exact location and size of the water storage tanks and the access roads.

G-22 INSURANCE

The Permittee shall take out and maintain workers compensation insurance as required by the State of California. The Permittee shall also secure liability insurance and such other insurance as required by state and/or federal law. A Certificate of Insurance is to be provided to the Planning/Building Department by the insurance carrier, and said insurance and certificate shall be kept current for the life of the project. Certificates of Insurance shall be sent directly to the Planning/Building Department by the insurance carrier and shall name the Department as a recipient of both renewal and cancellation notices.

(Total "G" Conditions are 22)

Remainder of Page Intentionally Left Blank

SPECIFIC CONDITIONS:

The "SPECIFIC CONDITIONS" are shown by the letter "S". These conditions are conditions "site specific" to this Conditional Use Permit. The Permittee is advised that the Specific Conditions are as applicable as the other types of conditions or mitigation measures within this Conditional Use Permit, or within those that are incorporated herein by reference whether included hereinafter or not!

FERTILIZER DISTRIBUTION & WAREHOUSE FACILITY:

S-1 The fertilizer distribution and warehouse business shall be permitted to receive, warehouse fertilizer via Union Pacific Railroad, and distribute the fertilizer via trucks. The facility will have capacity to store 14,075 tons of up to eight product segregations of dry fertilizer and 15,000 tons of up to four product segregations of liquid fertilizer. Fertilizer will be weighed by a 10'x80' fully electronic scale, upon receipt at the facility, and before shipping off-site to end user.

S-2 The entire site shall be maintained in a way as to control fugitive emissions, fire hazard, and odors. Measures may include, but are not necessarily limited to watering for dust suppression. A full site plan review shall be approved by Planning and Development Services Department, Fire/OES, EHS/Health Department, Public Works Department, and Agricultural Commissioner/APCD, before permits to operate the facilities will be issued.

HOURS OF OPERATION:

S-3 The facility may operate on a 24 hour day and a seven day per week basis. In the event that nuisances are reported and not resolved in a timely manner, the Planning and Development Services Department shall have the authority to reduce the permitted hours and days of operations, to the level necessary to abate the reported nuisance (see General Condition G-16).

MATERIAL INSPECTION AND HANDLING:

S-4 Prior to issuance of a Certificate of Occupancy Permittee shall prepare and submit to Environmental Health Services, Local Enforcement Agency, County Fire/OES Department, Department of Toxic Substances Control, Planning and Development Services Department, and applicable state and federal agencies, a detailed fertilizer handling plan for review and approval. A copy of any future revised plan shall be sent to Environmental Health Services, Local Enforcement Agency, County Fire/OES Department, Planning and Development Services Department, and applicable state and federal agencies for their review and approval prior to implementation of any changes.

EMERGENCY RESPONSE:

S-5 Prior to issuance of a Certificate of Occupancy, an Emergency Response Plan shall be developed and maintained as applicable by the Permittee and shall

be reviewed and approved by the County Fire/OES Department and the Imperial County Office of Emergency Services (OES).

FIRE PROTECTION:

S-6 Prior to issuance of a Certificate of Occupancy all facilities required for fire protection services shall be installed and in working order as approved by the Imperial County Fire/OES Departments. The permittee must install a fire suppression system that is tested and approved by the Imperial County Fire Department before any permit to operate is approved.

S-7 Prior to issuance of a Certificate of Occupancy, all automatic suppression systems, detection, venting and alarm systems will be tested for acceptance by the Imperial County Fire/OES.

S-8 Prior to issuance of a Certificate of Occupancy Permittee shall provide a trained emergency response team to handle plant accidents. Safety training shall be required and documented for all plant personnel and which will include, Chief Officers, Captions, Medical Responders, Fire Fighters, and facility personnel,. This training will include the steps personnel will take in reporting an emergency. All personnel on-site will be notified of an emergency via visual and audible mechanisms located throughout the facility. Personnel will know how to assist in denying entrance into the plant and knowledge of how to shut down all plant equipment during any emergency. Equipment will not be operated until the Incident Officer gives the approval to do so. A copy of the approved plan, as well as any future revised copy shall be sent to the Planning and Development Services Department, County Fire/OES Department and the Local Enforcement Agency/EHS for review and approval.

S-9 Prior to issuance of a Certificate of Occupancy, the Facility's fertilizer product containment area(s) shall be constructed by Permittee to accommodate both the product, in case of a fire, as well as the water needed to protect or extinguish the tanks. The containment areas need to be shown on site plan. Containment areas shall be reviewed and approved by Imperial County Fire/OES Department.

S-10 Prior to issuance of a Certificate of Occupancy a compatible suppression agent will be stored at project site and there will also be equipment and manpower on-site, to unload and move the suppression agent

S-11 Permittee shall supply waterlines to meet the current California Fire Code requirements.

S-12 Prior to issuance of a Certificate of Occupancy, no portion of any building can be more than 250 feet from a hydrant. Hydrants must be accessible to the apparatus by all-weather roads. The water storage calculation would have to be

determined as well as the supply line to the storage to ensure the flow and duration with all costs for testing and monitoring paid by Permittee.

S-13 The hydrants will have reflectors in the center of the roadways, and will be painted safety yellow.

S-14 Permittee shall indicate on the site plan where the product and water will be directed and retained for later removal of contaminated run-off.

S-15 ADDITIONAL FIRE REQUIREMENTS

1. An approved water supply capable of supplying the required fire flow determined by appendix B in the California Fire Code shall be installed and maintained. Private fire service mains and appurtenance shall be installed in accordance with NFPA 24. (FIRE DEPARTMENT LETTER DATE August 22, 2018).
2. An approved automatic fire suppression system shall be installed on all required structures as per the California Fire Code. All fire suppression systems will be installed and maintained to the current adapted fire code and regulations. (FIRE DEPARTMENT LETTER DATE August 22, 2018).
3. An approved automatic fire detection system shall be installed on all required structures as per the California Fire Code. All fire detection systems will be installed and maintained to the current adapted fire code and regulations. (FIRE DEPARTMENT LETTER DATE August 22, 2018).
4. Fire department access roads and gates will be in accordance with the current adapted fire code and the facility will maintain a Knox Box for access on site. (FIRE DEPARTMENT LETTER DATE August 22, 2018).
5. Compliance with all required sections of the fire code (FIRE DEPARTMENT LETTER DATE August 22, 2018).
6. Applicant shall provide product containment areas(s) for both product and water run-off in case of fire applications and retained for removal (FIRE DEPARTMENT LETTER DATE August 22, 2018).
7. Pay additional capital purchases to assist in servicing this project and costs for services during construction and life shall be approved by the Fire Department prior to the issuance of initial building and grading permits. (FIRE DEPARTMENT LETTER DATE August 22, 2018).

HEIGHT LIMITS:

S-16 Height limits for structures shall not exceed the height of 50' feet from ground level.

NOISE:

S-17 On-site noise shall be governed by CAL-OSHA standards and by the Imperial County General Plan, Noise Element, Mesquite Lake Specific Plan and Land Use Ordinance.

WASTE WATER:

S-18 Permittee shall meet all requirements specified in the Construction Activities (Storm Water and 401 Water Quality Certification) from the Colorado River Basin, Regional Water Quality Control Board.

- (a) Storm Water Construction General Permit 99-08-DWD
- (b) Industrial Stormwater Permit 97-03-DWQ

S-19 Permittee shall monitor waste water to drain in accordance with Discharge Permits (National Pollutant Discharge Elimination System Permit and Waste Discharge Requirements)

- (a) NPDES Permits
- (b) Waste Discharge Requirements

S-20 Permittee shall maintain a disposal system, as approved by EHS and DTSC, for any sanitary waste water.

S-21 Permittee shall maintain a retention basin for collection and evaporation or conveyance to the applicable Imperial Irrigation Drain for on-site storm water runoff.

AIR QUALITY:

S-22 Prior to the operation of the facility the Permittee shall meet all requirements of the Imperial County Air Pollution Control District (APCD) and shall obtain all required permits and approvals from APCD as required (an "Authority to Construct", the "Permit to Operate" and Air Quality Mitigation Measures), and provide to the Imperial County Planning and Development Services Department a copy of all approved APCD permits.

S-23 Permittee shall install all air pollution equipment as required by APCD and ensure that all vehicles used in the facilities (on-site vehicles, transport trucks, and other applicable motorized equipment) shall be in compliance with all local, state and federal clean air laws and regulations at all times.

S-24 The proposed avenue of traffic is by truck and railcar. The traffic study demonstrates that while the impact of the operation alone is not significant cumulatively, the impact becomes significant at certain intersections. Therefore, with the application of Rule 310, these emissions maybe avoided.

S-25 The proposed project shall implement applicable requirements under APCD Regulation VIII. According to the APCD CEQA Handbook, “the standard measures for construction equipment and fugitive PM10 control for construction activities should be implemented at all construction sites, as appropriate and feasible, regardless of the size”.

S-26 Maintain and tune all construction equipment according to manufacturer’s specifications.

S-27 Fuel all off-road and portable diesel powered equipment with CARB-certified motor vehicle diesel fuel (nontaxed version suitable for use off-road).

S-28 Prior to issuance of a Certificate of Occupancy an “Odor Abatement Plan” shall be prepared and instituted by the Permittee with approval by Environmental Health Services, APCD and Planning & Development Services Department. Permittee shall revise plan as required by the above agencies for continued compliance associated with odor abatement at project site.

S-29 After three months of operation, an additional odor survey shall be conducted based on monitoring and modeling methods approved by the County. The survey shall also identify and set odor limits based on odor units for each odor source at the facility as to abate any nuisance to off-site receptors. Quarterly monitoring shall be conducted to ensure compliance with the odor limits and report to Environmental Health Services and Imperial County Planning & Development Services Department on a quarterly basis. If problems or complaints occur, the Permittee shall abate such problems immediately

S-30 The entire site shall be pre-watered for 48 hours prior to clearing and grubbing. Reduce the amount of the disturbed area where possible. Water at least twice daily or otherwise stabilizes all active construction areas. All dirt stock-pile areas should be sprayed daily as needed. Pave, apply water three times daily, or apply (non-toxic) soil stabilizers on all unpaved access roads, parking areas, and staging areas at construction areas. Haul trucks shall cover loads or maintain at least 6 inches of freeboard when traveling on public roads. Pre-moisten, prior to transport, import and export materials that have silt content of 5% or greater. Water all materials with silt content of 5% or greater with a spray bar or cover trucks hauling dirt, sand, or loose materials. (Note that empty trucks and trucks carrying asphalt material are excluded from this requirement.) Sweep streets at the end of each day if visible soil material is carried on to streets, or wash off trucks and equipment leaving the site.

S-31 The project would not have significant PM10 impacts; however, the APCD requires that “discretionary measures for fugitive PM10 control be implemented as appropriate and feasible, at construction sites greater than, or equal to, four (4) acres.” Following are some of the APCD discretionary measures that shall be implemented for the proposed project:

S-32 Vehicle speeds for all construction vehicles shall not exceed 15 miles per hour on unpaved surface at the construction site. Plant ground cover in disturbed areas as soon as possible and where feasible. Cover or apply water to form and maintain a crust on inactive storage piles.

PRODUCT HANDLING/OPERATING/STORAGE PERMIT:

S-33 Prior to the COO and operation of the facility, the Permittee shall obtain all applicable required permits and approvals from the Local Enforcement Agency/Environmental Health Services/Health Department.

S-34 Hazardous material on the property that are equal to or greater than 55-gallons, 200 cubic feet of compressed gas at standard temperature and pressure, or 500 pounds, requires the facility to comply with the Hazardous Materials Release Response Plan and Inventories (Business Plan).

S-35 Should the facility manage hazardous material exceeding the regulatory thresholds including,

- a) any amount of hazardous waste generated onsite, any regulated substances above threshold listed in Table 1, 2 or 3 in Appendix a of the California Accidental Release Prevention (CalARP) Program regulations,
- b) The owner or operator of a tank facility has an aggregate above ground storage capacity greater than or equal to 1,320 gallons of petroleum, would be regulated under the Aboveground Petroleum Storage Act,
- c) the owner or operator has a tank system, including piping, that has 10% or more of the total volume of hazardous material or hazardous substance below grade would require a permit as an underground storage tank facility,

Applicant must contact DTSC Imperial CUPA to ensure compliance with applicable requirements before the facility commences operations.

SYSTEM SHUT DOWN AND SITE ABANDONMENT:

S-36 Prior to recordation of this CUP Agreement, the Permittee shall submit and file a bond, (or other form of security acceptable to Imperial County) in the amount as determined by the Planning and Development Services Director and in a form acceptable to County Counsel. Said bond (security) shall guarantee restoration of the land to its condition prior to development. Additionally, the bond (security) shall have an escalator factor equal to the Los Angeles region consumer price index (CPI).

S-37 When the operation of the facility herein authorized has ceased for any 24 month period, all facilities shall be dismantled and the land involved in the operation of the facility shall be restored to its original condition to the satisfaction of the Planning and Development Services Department. After satisfactory

completion of such restoration, the bond or security shall be released by the County.

SITE PLAN REVIEW:

S-38 Project building materials shall be limited to non-reflective materials, or non-glare materials. Reflective materials shall be coated with an industrial coating material.

S-39 Prior to issuance of building permits, Permittee shall submit an application for site plan review pursuant to the Imperial County Land Use Ordinance. The site plan review application shall consist of a site plan, structure elevations, parking plan, landscape plan, textual narrative on proposed project improvements, and the requisite review fees.

S-40 Prior to issuance of a Certificate of Occupancy the entire facility shall be fenced and maintained in accordance with the Mesquite Lake Specific Plan requirements. All perimeter fencing shall be solid (chain link with slats) and non-translucent or reflective, with the Project frontage (Harris Road having a decorative block wall. Fencing shall be approved by the Planning and Development Services.

LANDSCAPING:

S-41 Permittee shall prepare a landscaping plan (in accordance with the Mesquite Lake Specific Plan. The plan must be reviewed and approved by the Planning and Development Services Department. The landscaping plan shall be done prior to the issuance of building permits. All landscaping must be completed prior to issuance of a Certificate of Occupancy. At a minimum landscaping shall be installed and maintained along the entire perimeter of the site with special attention and concentration along the project frontage (Harris Road) and entrance.

S-42 Permittee shall ensure all signage is in accordance with Imperial County Land Use Ordinance.

HYDROLOGY AND WATER QUALITY

S-43 Prior to the issuance of grading permits permittee shall prepare a Storm Water Pollution and Prevention Plan (SWPPP) to be administered through all phases of grading and project construction. The SWPPP must incorporate Best Management Practices (BMP's) meeting technical standards of the General Construction permit to ensure that potential water quality impacts (including on-site and off-site erosion) during construction phases are minimized and that violation of water quality standards do not occur.

The SWPPP must address spill prevention and include a countermeasure plan describing measures to ensure proper collection and disposal of all pollutants handled or produced on the site during construction, including sanitary wastes, cement, and petroleum products. BMP's included in the SWPPP must be consistent with the California Stormwater Best Management Practices Handbook for Construction. The SWPPP must be submitted to the Region 7 Regional Water Quality Control Board and to Imperial County Public Works for review.

S-44 Prior to issuance of a Certificate of Occupancy permittee shall prepare a Storm Water Pollution and Prevention Plan (SWPPP) governing industrial operations to be administered so long as industrial activities are ongoing. The Industrial SWPPP must incorporate Best Management Practices (BMP's) meeting the technical standards of the General Industrial Permit to ensure that potential water quality impacts during the operational phase are minimized and that violations of water quality standards do not occur. The Industrial SWPPP will include permanent post-construction BMP's meeting the County's requirements under its program implementing the Small MS4 Permit. These post-construction BMP's will be included in the Industrial SWPPP and must be consistent with the California Storm-water Best Management Practices Handbook for Commercial and Industrial operations. The BMP's will include the implementation of detention basins, collectively sized to retain a 100-year frequency storm event from the project site. These detention basins will meet design standards imposed by the County and the Imperial Irrigation District (IID), including draining within 72 hours following a storm event and having outlet structures no larger than 12 inches in diameter and containing a backflow prevention device. The Industrial SWPPP must be submitted to the Region 7 Regional Water Quality Control Board and to Public Works for review.

S-45 Permittee shall obtain IID encroachment permits(s) required for all proposed water, sewer, storm-water, and any other underground utilities that will encroach upon existing and proposed IID right-of-ways. IID permit(s) are also required for all surface improvements, including proposed new streets, driveways, parking lots, and landscape that will encroach upon existing and proposed IID right-of-ways. 5

S-46 IID records indicate that tile lines may exist within the project site. The existing agricultural underground tile system is to be severed and plugged. Non-agricultural subsurface discharge into the IID drainage system is prohibited.

BIOLOGICAL RESOURCES

S-47 The Permittee shall conduct a pre-construction survey within 30 days prior to the commencement of construction activities. Said survey shall be conducted by a qualified biologist in coordination with the United States Department of Fish and Wildlife Services and the State of California Fish & Game Department (CDFG) to determine the presence or absence of active burrowing owl nests within or adjacent to the project site.

S-48 If construction occurs between February 1st and August 31st, a pre-construction survey, within 3 days prior to the commencement of construction activities, shall be conducted by a qualified biologist to determine the presence or absence of active nests of birds included under the protections of the MBTA within or adjacent to the project site.

S-49 Burrowing owl nesting sites shall be flagged and avoided by construction crews. Construction equipment shall be parked within the project area and at least 250 feet away from burrowing owl nesting sites in pre-established construction parking areas and crew members shall be notified to remain 250 feet away from the burrows.

S-50 Construction of the project shall be designed to keep all impacts to sensitive species to a minimum. All attempts to avoid construction within 250 feet of nesting burrowing owls shall be made. If breeding/nesting activity is confirmed, construction activities shall not occur within 250 feet of the active nest until the young birds have fledged and left the nest, as confirmed by a qualified biologist.

S-51 If burrows are to be removed or destroyed by project activities, a consultation with CDFG shall be initiated to determine effective mitigation measures. Possible mitigation could include, but not limited to, installation of artificial burrows; passive relocation, sheltering in place, providing suitable habitat in substitution for any habitat that is being removed by this project, and/or worker training. CDFG-approved mitigation shall be implemented prior to disturbance of the burrows.

CULTURAL & PALEONTOLOGICAL RESOURCES

S-52 The Imperial County Planning and Development Services Department shall be notified immediately if any cultural resources (e.g., prehistoric or historic artifacts) or paleontological resources (e.g., fossils) are uncovered during construction. All construction must stop in vicinity of the find and an archaeologist that meets the Secretary of the Interior's Professional Qualifications Standards in prehistoric or historical archaeology shall be retained to evaluate the finds and recommend appropriate action.

S-53 If human remains are discovered, all work must stop in the immediate vicinity of the find, the Imperial County Planning and Development Services Department shall be notified immediately, and the County Coroner must be notified according to Section 7050.5 of California's Health and Safety Code. If the remains are determined to be Native American, the coroner will notify the Native American Heritage Commission, and the procedures outlined in CEQA Section 15064.5(d) and (e) shall be followed.

HAZARDS AND HAZARDOUS MATERIALS

S-54 A Hazardous Materials Business Plan shall be prepared in accordance with Title 19, Division 2, Chapter 4, and Article 4 of California Code of Regulations. The Hazardous Material Inventory shall be updated annually to the Imperial County Fire/OES Department and the Imperial County Office of Emergency Services, prior to the approval of the grading plan.

S-55 Prior to issuance of a grading plan an Emergency Response Plan shall be prepared by the Permittee in coordination with local fire agencies and the County of Imperial. The Emergency Response Plan shall be updated annually in coordination with the Imperial County Fire/OES Department and the Imperial County Office of Emergency Services (EHS).

S-56 Prior to issuance of building permits an agreement shall be created and implemented with the Permittee and the applicable Fire/OES Department to address special fire services required to service the proposed project. The agreement shall be enacted.

S-57 If the project proposes to store hazardous wastes for greater than 90 days, a State of California Department of Toxic Substance Control (DTSC) hazardous waste facility permit shall be required.

S-58 The project construction may require soil excavation and soil filling in certain areas. Appropriate sampling is required prior to disposal of the excavated soils. If the soil is contaminated it shall be properly disposed of rather than placing it in another location. If the project proposes to import soil to backfill the areas excavated, proper sampling should be conducted to make sure that the imported soil is free of contamination.

S-59 The Permittee shall provide evidence to the Local Enforcement Agency (LEA)

(1) a determination has been made by the County EHS Division on the need for project approval under the CalARP Program to prevent accidental release of regulated toxic and flammable substances from stationary sources that handle more than the threshold quantity of regulated substances; and if applicable to the project,

(2) All local, state, and federal permit requirements to prevent accidental release of regulated toxic and flammable substances pursuant to the CalARP Program have been satisfied, including the requirement for preparation of a Risk Management Plan and an Emergency Response Program.

SEISMICITY/GEOLOGY AND SOILS

S-60 The project site is located in a seismically active area. The Permittee shall design the project in accordance with all applicable seismic and building codes. In addition, prior to Project Construction, site-specific geotechnical investigations shall be performed by a qualified professional to reduce the potential for structural damage to facilities and corollary indirect impacts associated with strong seismic ground shaking.

GEOLOGY/SOILS and MINERAL RESOURCES

S-61 Prior to approval of final engineering and grading plans for the project, the County shall verify that all recommendations contained in the *Geotechnical Report for the JR Simplot Fertilizer Terminal NWC Harris Road and UPRR Tracks* prepared by Landmark Consultants, Inc. (December 2018) have been incorporated into all final engineering and grading plans. The County's soil engineer and engineering geologist shall review grading plans prior to finalization, to verify compliance with the recommendations of the report. All future grading and construction of the project site shall comply with the geotechnical recommendations contained in the geotechnical report.

TRAFFIC CONTROL/ PUBLIC SERVICES AND UTILITIES

S-63 Prior to issuance of a Certificate of Occupancy a traffic control plan shall be prepared and submitted to the Department of Public Works, for implementation by the Permittee to maintain adequate circulation and access for emergency response vehicles.

S-64 Prior to issuance of a building permit, Permittee shall verify that an adequate water supply be provided for the project.

S-65 Prior to issuance of any building permit for any new building within the project, the Permittee shall provide evidence from IID Energy that adequate electrical service exists for the project or that required new facilities would be available.

S-66 Prior to the issuance of building permits permittee shall verify the ability by Southern California Gas Company (SCGC) for natural gas service to provide adequate natural gas for the proposed project.

S-67 The Permittee, in consultation with Union Pacific Railroad and California Public Utilities Commission, shall ensure that the existing railroad crossing shall conform to all Federal, State, and local laws and regulations.

S-68 Prior to issuance of any building permit for any new building within the project, the Permittee shall provide evidence from IID that water service exists for the project, including for irrigation of landscape areas and dust control, and shall provide facilities for on-site treatment of raw water or for storage and distribution of delivered filtered water for hand washing and other sanitary requirements. All facilities required for adequate water service shall be installed and in working order prior to issuance of a Certificate of Occupancy.

S-69 All grading, drainage and retention basin designs shall meet minimum standards within the latest Department of Public Works "County Design Guidelines Manual." Retention pond(s) and all drainage appurtenances, including inlet and outlet structures and storm drain lines are to be maintained by the Permittee. 8

S-70 All Public Improvement Plans and Grading and Drainage Plans shall be reviewed and approved by the Department of Public Works prior to construction of facility by the Permittee. All public improvements must meet the most current County Department of Public Works design guidelines and standards prior to approval.

S-71 The County is implementing a storm water management program as required by the State Water Resources Control Board, which may modify or add to the requirements and guidelines presented elsewhere in this document. This can include on-going monitoring of water quality of storm drain run-off, implementation of Best Management Practices (BMP's) to reduce storm water quality impacts downstream or along adjacent properties. The Permittee shall comply with all required storm water provisions as directed or as approved by Public Works Department.

S-72 Prior to issuance of any building permit, the Permittee shall provide evidence that an adequate system for wastewater disposal exists for the project. All facilities required for adequate wastewater disposal and process water

evaporation shall be installed and in working order prior to issuance of a Certificate of Occupancy.

TRAFFIC/CIRCULATION

S-73

- a. SR-86 is a 65 MPH facility at the intersection with West Harris Road. Trucks are to comply with all California Vehicle Code regulations entering/exiting the facility.
- b. Submit documentation that the type of truck proposed to be used along West Harris Road is allowed by the local agency.
- c. Submit truck turning templates for the type of truck that will be used on your project at the SR-86/West Harris Road intersection.

S-74 Due to the expected truck and vehicular trips, as a minimum, Harris Road shall require a standard commercial type driveway entrance as depicted on Imperial County Department of Public Works Drawing Number: County-410B prior to issue of any building permits.

S-75 The project applicant shall provide a dedicated eastbound left-turn lane and a westbound turn lane on Harris Road at the project driveway and ensure County sight distance requirements are met at this location to the satisfaction of Public Works Department. Half width road improvements shall be provided which include, curb, and gutter and sidewalk and infill paving along the project frontage.

S-76 Prior to issue of any building permits, the applicant must pay a fair share for the signal light at SR-86/Harris Road. The Fair Share amount of 0.2% shall be paid to Planning & Development Services Department.

S-77 Prior to issue of any building permits, the applicant must pay a fair share for the road improvements and traffic light at SR-86/Keystone Road intersection. The Fair Share amount of 0.3% shall be paid to Planning & Development Services Department.

S-78 Prior to issue of any building permits, the applicant must pay a fair share for the road improvements on Dogwood Road from Keystone Road to Harris Road. The Fair Share amount of 0.5% shall be paid to Planning & Development Services Department.

S-79 Prior to issue of any building permits, the applicant must pay a fair share for the road improvements on Dogwood from Harris Road to Worthington Road. The Fair Share amount of 0.3% shall be paid to Planning & Development Services Department.

S-80 Prior to issue of any building permits, the applicant must pay a fair share of 0.2% to Planning & Development Services Department for improvements to lengthen the northbound right turn lane to 500 feet, plus a bay taper of 120 feet with a 4 foot shoulder along Highway 86/Harris Road.

S-81 Prior to issue of any building permits, the applicant must pay a fair share of 0.2% to Planning and Development Services for improvements to lengthen the southbound left turn lane to 500 feet, plus a 120 foot bay taper along Highway 86/Harris Road.

S-82 The truck turn radii will need to be evaluated for all proposed curb returns on SR-86

S-83 Prior to issue of any building permits, an encroachment permit shall be secured for any and all new, altered or unauthorized existing driveways, alteration to public roads and/or connections to public roads that may be necessary to access the properties. Entrance improvements shall meet the appropriate agency's standards, requirements, and/or approvals in effect at the time of construction. A permit must also be issued to include any work within the County road right-of-way such as under-grounding and overhead (dry and wet) utilities and road infrastructures, if required.

S-84 Transportation Permits shall be required for any over-legal loads being transported within County Roads.

S-85 Prior to the Certificate of Occupancy the Permittee shall submit the Traffic Impact fee of \$82.00/ADT (Average Daily Trips) to the County, which equal **108 motor vehicles X \$82.00 for a total of \$8,856**, to off-set the increased traffic impacts to county roads. Said 108 motor vehicles include crew, trucks, general service, miscellaneous as identified in the Traffic Study.

S-86 Permittee shall make arrangements with the Quechan Indian Tribe Ft. Yuma Indian Reservation for tribal monitors to be present for the ground disturbing activities related to this project.

S-87 Legal and Physical access shall be required along west side of parcel 040-340-043 north to the Dahlia Lateral Eight as shown in the approved Mesquite Lake Specific Plan (Circulation Plan on page 61). This access is for future development of a 4 Lane Industrial Collector Road. Please see figure 8 of the Mesquite Lake SP Development Phasing and Infrastructure Plan.

S 88 PUBLIC SERVICES:

- (1) If Permittee receives an exclusion of applicable sales and use tax payable to the County of Imperial under Senate Bill 71 under the State Public Resource Code (Section 26003, et al.) and the California Alternative Energy and Advanced Transportation Financing Authority (CAETFA), Permittee shall pay to the County and Local Transportation Authority an amount equal to the sales tax (currently at 1.5%) which would have been received if Permittee had not obtained such exclusion.
- (2) Permittee shall require that its general construction contractor exercise its option to obtain a Board of Equalization (BOE) sub-permit for the jobsite and allocate all eligible use tax payments to Imperial County and LTA. Permittee will require that the general contractor provide County of Imperial with either a copy of their BOE account number and sub-permit. To accomplish this, Permittee shall either cause its general construction contractor to treat the project in accordance with California Regulation 1521(b)(2)(B), California Regulation 1521(c)(13)(B), and California Regulation 1826(b) for sales and use tax purposes or form a "Buying Company" as defined in the State of California Board of Equalization Regulation 1699(h). Permittee can adopt an alternate methodology to accomplish this goal if such methodology is approved by the County Executive Officer prior to issuance of building permits. Permittee shall require its general construction contractor to use commercially reasonable best efforts to cause its subcontractors and vendors to obtain similar sub-permits for the jobsite and to allocate all eligible sales and use tax payment to Imperial County and LTA.
- (3) Permittee shall direct use taxes on out-of-County taxable purchased construction related items to Imperial County, to the extent permitted and consistent with state use tax law.
- (4) Permittee shall use its best efforts, consistent with state law, to source taxable purchases from price competition construction retail vendors within the County of Imperial in order to further source sales to County.
- (5) The Permittee shall exclude from assessment and taxation under California Revenue and Taxation Code Section 73 (AB 1451) only that property qualifying as an Active Solar Energy System, pursuant to the applicable guidelines issued by the Board of Equalization.
- (6) The Permittee shall install and implement security measures which may include, but not limited to, secured perimeter fencing with barbed wire, sensors, with controlled access points, security alarms, security camera systems, security guard vehicle patrols to deter trespass or unauthorized activities that would interfere with operation of the proposed project.
- (7) Permittee shall compensate the County pursuant to the Department of Environmental Health Fee Schedule for any costs of calls related to bees and mosquitoes.

- (8) The Permittee shall reimburse the Sheriff's Department for any investigations regarding theft on the Project site and related law enforcement.
- (9) All construction supervisors and foremen shall be provided with communication devices, cell phones or walkie-talkies, in the event of an emergency situation on-site.
- (10) All construction-related activities shall take place within the development footprint of the Project as defined by the final engineering plans. The anticipated impact areas, including staging areas, equipment access, and disposal or temporary placement of spoils, shall be delineated with staking and/or orange construction fencing prior to construction to avoid natural resources where possible. No construction-related activities shall occur outside of the designated impact area. All construction materials, staging, storage, dispensing, fueling, and maintenance activities shall be designated on construction maps and shall be situated a minimum of fifty (50) feet from all drainages. Staging and temporary access shall occur on existing roadways whenever possible.

S-89 REPORTING AND MONITORING:

1. The Permittee shall furnish to the County, at its sole cost within a reasonable time, any relevant reports/information which the County requires for monitoring purposes to determine whether cause exists for revoking this permit, or to determine compliance with this permit. The Permittee shall submit all required reports to the Planning Director, County Planning and Development Services Department, 801 Main Street, El Centro, CA 92243.
2. Permittee and Imperial County Planning and Development Services Department Director shall agree upon an environmental consultant for overseeing all the required mitigation, conditional use permit conditions requirements during the construction of project.
3. Permittee shall pay for a third party environmental consultant monitoring and compliance during the construction phase of project.
4. The Planning and Development Services Department, in consultation with the third party Environmental Consultant and the County Executive Office, will require that all mitigation measures be satisfied, all mitigation monitoring and Reporting Program requirements have been satisfied, Conditions of Approval in the Conditional Use Permit are in full compliance and have been satisfied before the Final Certificate of Occupancy Certificate is issued.
5. During the operation of solar facility, an Annual Compliance Report shall be submitted to the Imperial County Planning and Development Services Department, documenting the implementation of the conditions and general measures as well as any resource-specific measures.

6. Permittee shall pay for all costs as required to comply with the Conditions of Approval and MMRP

7. All County staff time will be billed on a time and materials basis. Failure by Permittee to provide any payment required of Permittee to the County in the CUP shall cause Permittee to be in non-compliance of the CUP. Upon Permittee being in such noncompliance, County may, at its sole discretion, cease processing, defending any lawsuit or paying for costs associated with the Project.

End notes:

- 1 Imperial County Fire Department Letter, dated August 22, 2018
- 2 Department of Transportation/Planning letter dated 8-23-2018
- 3 Campo Band of Mission Indians 10-25-2018
- 4 Augustine Band of Cahuilla Indians dated 8/05/2019
- 5 IID Letter, dated March 25, 2008
- 6 Caltrans dated July 16, 2019
- 7 Air Pollution Control District letter dated 08/21/2018 & 07/15/2019
- 8 Public Works Letters, dated 1-22-2019
- 9 Imperial Irrigation District letter dated 08/21/2018

Remainder of Page left intentionally blank

NOW THEREFORE, County hereby issues Conditional Use Permit #18-0020, Permittee hereby accepts such permit upon the terms and conditions set forth herein:

IN WITNESS THEREOF, the parties hereto have executed this Agreement the day and year first written.

PERMITTEE:

By: _____ Date _____
Representative of J.R. Simplot, Inc.

COUNTY OF IMPERIAL, a political subdivision of the STATE OF CALIFORNIA:

By: _____ Date _____
JAMES A. MINNICK,
Planning and Development Services Director

FOR PERMITTEE NOTARIZATION

STATE OF CALIFORNIA

COUNTY OF IMPERIAL} S.S.

On _____ before me, _____,
personally _____ appeared

_____, who proved to me
on the basis of satisfactory evidence to be the person(s) whose name(s) is/are
subscribed to the within instrument and acknowledged to me that he/she/they
executed the same in his/her/their authorized capacity(ies), and that by
his/her/their signature(s) on the instrument the person(s), or the entity upon
behalf of which the person(s) acted, executed the instrument.

I certify under PENALTY OF PERJURY under the laws of the State of California
that the foregoing paragraph is true and correct.

WITNESS my hand and official seal

Signature _____

ATTENTION NOTARY: Although the information requested below is OPTIONAL, it could prevent fraudulent attachment of
this certificate to unauthorized document.

Title or Type of Document _____

Number of Pages _____ Date of Document _____

Signer(s) Other Than Named Above _____

FOR COUNTY NOTARIZATION

STATE OF CALIFORNIA

COUNTY OF IMPERIAL} S.S.

On _____ before me, _____,
personally appeared Jurg Heuberger, who proved to me on the basis of
satisfactory evidence to be the person(s) whose name(s) is/are subscribed to the
within instrument and acknowledged to me that he/she/they executed the same
in his/her/their authorized capacity(ies), and that by his/her/their signature(s) on
the instrument the person(s), or the entity upon behalf of which the person(s)
acted, executed the instrument.

I certify under PENALTY OF PERJURY under the laws of the State of California
that the foregoing paragraph is true and correct.

WITNESS my hand and official seal

Signature _____

ATTENTION NOTARY: Although the information requested below is OPTIONAL, it could prevent fraudulent attachment of
this certificate to unauthorized document.

Title or Type of Document _____

Number of Pages _____ Date of Document _____

Signer(s) Other Than Named Above _____

S:\APN FILES\040\340\043\CUP AGREEMENT FOR JR SIMPLOT Final 082508.doc

(EEC Package)

MITIGATION, MONITORING AND REPORTING PROGRAM

MITIGATION MEASURES PURSUANT TO THE ENVIRONMENTAL EVALUATION COMMITTEE

J.R. Simplot Company
[CUP #18-0020]

(APN 040-430-043-000)

(CEQA – Mitigated Negative Declaration)

Pursuant to the review and recommendations of the Imperial County Environmental Evaluation Committee (EEC) on June 13, 2019, the following Mitigation Measures & Mitigation Monitoring and Reporting Program are hereby recommended for approval for Conditional Use Permit #18-0020:

Biological Resources:

MITIGATION MEASURE #1: (for a)

- Burrowing Owl (BUOW) shelter in place (using hay bales) and remove shelters when project is complete under supervision of qualified biologist. If passive relocation are required, a qualified biologist shall consult with California Department of Fish and Wildlife (CDFW), Palm Desert Office.
- Worker BUOW training sessions.
- Monitoring when construction is within 250 feet (February – August); 160 feet (September – January) if determined necessary by qualified biologist.
- If Construction starts during Migratory Bird Nesting season (February – August) a nesting bird survey should be completed one week prior to start of construction.
- Within 14 days and 24 hours of start of construction, BUOW survey.

(Monitoring Agency: California Department of Fish and Wildlife (CDFW)/Planning & Development Services Department)

Geology and Soils:

MITIGATION MEASURE #2: (1 & 2)

- Type C backfill must be used in wet soils and below groundwater for all buried utility pipelines. Where pipeline excavation are planned below the ground water surface, dewatering (by well points) is required to at least 24 inches below the trench bottom prior to excavation. Type A backfill may be used in the case of a dewatered trench condition in clay soils only.

(Monitoring Agency: Planning & Development Services Department)

Utilities and service systems:

MITIGATION MEASURE #3 (C)

- Prior to issuance of any building permit for any new building within the project, development impact mitigation fees as provided by the County Municipal Code. In addition, the building permit application shall be evidence to the satisfaction of the Planning and Development Services Director and Fire Chief that an adequate system of water storage and pumping for fire protection exists for the project or will be constructed and available for use upon completion of the building. This shall include an agreement between the applicant and property owner with the County Fire Department that a specific minimum volume of water in the storage pond will be maintained at all times. All facilities required for fire protection services shall be installed and in working order prior to issuance of a certificate of occupancy for the building.

(Monitoring Agency: Fire Department/Planning & Development Services Department)

PROJECT REPORT

TO: ENVIRONMENTAL EVALUATION
COMMITTEE

AGENDA DATE: June 13, 2019

FROM: PLANNING & DEVELOPMENT SERVICES

AGENDA TIME 1:30 PM / No. 1

PROJECT TYPE: CUP #18-0020 (J.R. Simplot Company) SUPERVISOR DIST # 3

LOCATION: 318 W. Harris Road APN: 040-340-043-000

Imperial, CA PARCEL SIZE: (±)39.96 AC

GENERAL PLAN (existing) Mesquite Lake Specific Plan GENERAL PLAN (proposed) N/A

ZONE (existing) MLI-2 (Mesquite Lake Medium Industrial) ZONE (proposed) N/A

GENERAL PLAN FINDINGS CONSISTENT INCONSISTENT MAY BE/FINDINGS

PLANNING COMMISSION DECISION:

HEARING DATE: _____

APPROVED DENIED OTHER

PLANNING DIRECTORS DECISION:

HEARING DATE: _____

APPROVED DENIED OTHER

ENVIRONMENTAL EVALUATION COMMITTEE DECISION: HEARING DATE: 06/13/2019

INITIAL STUDY: #18-0017

NEGATIVE DECLARATION MITIGATED NEG. DECLARATION EIR

DEPARTMENTAL REPORTS / APPROVALS:

PUBLIC WORKS	<input type="checkbox"/>	NONE	<input checked="" type="checkbox"/>	ATTACHED
AG	<input checked="" type="checkbox"/>	NONE	<input checked="" type="checkbox"/>	ATTACHED
APCD	<input type="checkbox"/>	NONE	<input checked="" type="checkbox"/>	ATTACHED
E.H.S.	<input checked="" type="checkbox"/>	NONE	<input type="checkbox"/>	ATTACHED
FIRE / OES	<input type="checkbox"/>	NONE	<input checked="" type="checkbox"/>	ATTACHED
SHERIFF	<input checked="" type="checkbox"/>	NONE	<input type="checkbox"/>	ATTACHED
OTHER				

See Attached

REQUESTED ACTION:

(See Attached)

Planning & Development Services
801 MAIN STREET, EL CENTRO, CA, 92243 442-265-1736
(Jim Minnick, Director)

GMJHIS:\APN\040\340\043\CUP #18-0020\EEC Pkg\CUP 18-0020 -EEC PROJREPT.docS:\APN\040\340\043\CUP #18-0020\EEC Pkg\CUP 18-0020 -EEC PROJREPT.doc

EEC ORIGINAL PKG

- NEGATIVE DECLARATION**
 MITIGATED NEGATIVE DECLARATION

*Initial Study & Environmental Analysis
For:*

**Conditional Use Permit #18-0020
J.R. Simplot Company**



Prepared By:

COUNTY OF IMPERIAL
Planning & Development Services Department
801 Main Street
El Centro, CA 92243
(442) 265-1736
www.icpds.com

June 2019

EEC ORIGINAL PKG

TABLE OF CONTENTS

	<u>PAGE</u>
<u>SECTION 1</u>	
I. INTRODUCTION	3
<u>SECTION 2</u>	
II. ENVIRONMENTAL CHECKLIST	8
PROJECT SUMMARY	10
ENVIRONMENTAL ANALYSIS	13
I. AESTHETICS	15
II. AGRICULTURE AND FOREST RESOURCES	15
III. AIR QUALITY	16
IV. BIOLOGICAL RESOURCES	17
V. CULTURAL RESOURCES	18
VI. ENERGY	18
VII. GEOLOGY AND SOILS	18
VIII. GREENHOUSE GAS EMISSION	20
IX. HAZARDS AND HAZARDOUS MATERIALS	20
X. HYDROLOGY AND WATER QUALITY	21
XI. LAND USE AND PLANNING	22
XII. MINERAL RESOURCES	23
XIII. NOISE	23
XIV. POPULATION AND HOUSING	23
XV. PUBLIC SERVICES	24
XVI. RECREATION	24
XVII. TRANSPORTATION	25
XVIII. TRIBAL CULTURAL RESOURCES	25
XIX. UTILITIES AND SERVICE SYSTEMS	25
XX. WILDFIRE	25
<u>SECTION 3</u>	
III. MANDATORY FINDINGS OF SIGNIFICANCE	29
IV. PERSONS AND ORGANIZATIONS CONSULTED	30
V. REFERENCES	31
VI. NEGATIVE DECLARATION - COUNTY OF IMPERIAL	32
27 FINDINGS	33
<u>SECTION 4</u>	
VIII. RESPONSE TO COMMENTS (IF ANY)	34
IX. MITIGATION MONITORING & REPORTING PROGRAM (MMRP) (IF ANY)	35

SECTION 1 INTRODUCTION

A. PURPOSE

This document is a policy-level, project level Initial Study for evaluation of potential environmental impacts resulting with the proposed Conditional Use Permit #18-0020 (Refer to Exhibit "A" & "B"). For purposes of this document, the Conditional Use Permit will be called the "proposed project".

B. CALIFORNIA ENVIRONMENTAL QUALITY ACT (CEQA) REQUIREMENTS AND THE IMPERIAL COUNTY'S GUIDELINES FOR IMPLEMENTING CEQA

As defined by Section 15063 of the State California Environmental Quality Act (CEQA) Guidelines and Section 7 of the County's "CEQA Regulations Guidelines for the Implementation of CEQA, as amended", an Initial Study is prepared primarily to provide the Lead Agency with information to use as the basis for determining whether an Environmental Impact Report (EIR), Negative Declaration, or Mitigated Negative Declaration would be appropriate for providing the necessary environmental documentation and clearance for any proposed project.

According to Section 15065, an EIR is deemed appropriate for a particular proposal if the following conditions occur:

- The proposal has the potential to substantially degrade quality of the environment.
- The proposal has the potential to achieve short-term environmental goals to the disadvantage of long-term environmental goals.
- The proposal has possible environmental effects that are individually limited but cumulatively considerable.
- The proposal could cause direct or indirect adverse effects on human beings.

According to Section 15070(a), a **Negative Declaration** is deemed appropriate if the proposal would not result in any significant effect on the environment.

According to Section 15070(b), a **Mitigated Negative Declaration** is deemed appropriate if it is determined that though a proposal could result in a significant effect, mitigation measures are available to reduce these significant effects to insignificant levels.

This Initial Study has determined that the proposed applications will not result in any potentially significant environmental impacts and therefore, a Negative Declaration is deemed as the appropriate document to provide necessary environmental evaluations and clearance as identified hereinafter.

This Initial Study and Mitigated Negative Declaration are prepared in conformance with the California Environmental Quality Act of 1970, as amended (Public Resources Code, Section 21000 et. seq.); Section 15070 of the State & County of Imperial's Guidelines for Implementation of the California Environmental Quality Act of 1970, as amended (California Code of Regulations, Title 14, Chapter 3, Section 15000, et. seq.); applicable requirements of the County of Imperial; and the regulations, requirements, and procedures of any other responsible public agency or an agency with jurisdiction by law.

Pursuant to the County of Imperial Guidelines for Implementing CEQA, depending on the project scope, the County of Imperial Board of Supervisors, Planning Commission and/or Planning Director is designated the Lead Agency,

in accordance with Section 15050 of the CEQA Guidelines. The Lead Agency is the public agency which has the principal responsibility for approving the necessary environmental clearances and analyses for any project in the County.

C. INTENDED USES OF INITIAL STUDY AND NEGATIVE DECLARATION

This Initial Study and Mitigated Negative Declaration are informational documents which are intended to inform County of Imperial decision makers, other responsible or interested agencies, and the general public of potential environmental effects of the proposed applications. The environmental review process has been established to enable public agencies to evaluate environmental consequences and to examine and implement methods of eliminating or reducing any potentially adverse impacts. While CEQA requires that consideration be given to avoiding environmental damage, the Lead Agency and other responsible public agencies must balance adverse environmental effects against other public objectives, including economic and social goals.

The Initial Study and Mitigated Negative Declaration, prepared for the project will be circulated for a period of 20 days (30-days if submitted to the State Clearinghouse for a project of area-wide significance) for public and agency review and comments. At the conclusion, if comments are received, the County Planning & Development Services Department will prepare a document entitled "Responses to Comments" which will be forwarded to any commenting entity and be made part of the record within 10-days of any project consideration.

D. CONTENTS OF INITIAL STUDY & NEGATIVE DECLARATION

This Initial Study is organized to facilitate a basic understanding of the existing setting and environmental implications of the proposed applications.

SECTION 1

I. INTRODUCTION presents an introduction to the entire report. This section discusses the environmental process, scope of environmental review, and incorporation by reference documents.

SECTION 2

II. ENVIRONMENTAL CHECKLIST FORM contains the County's Environmental Checklist Form. The checklist form presents results of the environmental evaluation for the proposed applications and those issue areas that would have either a significant impact, potentially significant impact, or no impact.

PROJECT SUMMARY, LOCATION AND ENVIRONMENTAL SETTINGS describes the proposed project entitlements and required applications. A description of discretionary approvals and permits required for project implementation is also included. It also identifies the location of the project and a general description of the surrounding environmental settings.

ENVIRONMENTAL ANALYSIS evaluates each response provided in the environmental checklist form. Each response checked in the checklist form is discussed and supported with sufficient data and analysis as necessary. As appropriate, each response discussion describes and identifies specific impacts anticipated with project implementation.

SECTION 3

III. MANDATORY FINDINGS presents Mandatory Findings of Significance in accordance with Section 15065 of the CEQA Guidelines.

IV. PERSONS AND ORGANIZATIONS CONSULTED identifies those persons consulted and involved in

preparation of this Initial Study and Negative Declaration.

V. REFERENCES lists bibliographical materials used in preparation of this document.

VI. NEGATIVE DECLARATION – COUNTY OF IMPERIAL

VII. FINDINGS

SECTION 4

VIII. RESPONSE TO COMMENTS (IF ANY)

IX. MITIGATION MONITORING & REPORTING PROGRAM (MMRP) (IF ANY)

E. SCOPE OF ENVIRONMENTAL ANALYSIS

For evaluation of environmental impacts, each question from the Environmental Checklist Form is summarized and responses are provided according to the analysis undertaken as part of the Initial Study. Impacts and effects will be evaluated and quantified, when appropriate. To each question, there are four possible responses, including:

1. **No Impact:** A "No Impact" response is adequately supported if the impact simply does not apply to the proposed applications.
2. **Less Than Significant Impact:** The proposed applications will have the potential to impact the environment. These impacts, however, will be less than significant; no additional analysis is required.
3. **Less Than Significant With Mitigation Incorporated:** This applies where incorporation of mitigation measures has reduced an effect from "Potentially Significant Impact" to a "Less Than Significant Impact".
4. **Potentially Significant Impact:** The proposed applications could have impacts that are considered significant. Additional analyses and possibly an EIR could be required to identify mitigation measures that could reduce these impacts to less than significant levels.

F. POLICY-LEVEL or PROJECT LEVEL ENVIRONMENTAL ANALYSIS

This Initial Study and Mitigated Negative Declaration will be conducted under a policy-level, project level analysis. Regarding mitigation measures, it is not the intent of this document to "overlap" or restate conditions of approval that are commonly established for future known projects or the proposed applications. Additionally, those other standard requirements and regulations that any development must comply with, that are outside the County's jurisdiction, are also not considered mitigation measures and therefore, will not be identified in this document.

G. TIERED DOCUMENTS AND INCORPORATION BY REFERENCE

Information, findings, and conclusions contained in this document are based on incorporation by reference of tiered documentation, which are discussed in the following section.

1. Tiered Documents

As permitted in Section 15152(a) of the CEQA Guidelines, information and discussions from other documents can be included into this document. Tiering is defined as follows:

"Tiering refers to using the analysis of general matters contained in a broader EIR (such as the one prepared

for a general plan or policy statement) with later EIRs and negative declarations on narrower projects; incorporating by reference the general discussions from the broader EIR; and concentrating the later EIR or negative declaration solely on the issues specific to the later project."

Tiering also allows this document to comply with Section 15152(b) of the CEQA Guidelines, which discourages redundant analyses, as follows:

"Agencies are encouraged to tier the environmental analyses which they prepare for separate but related projects including the general plans, zoning changes, and development projects. This approach can eliminate repetitive discussion of the same issues and focus the later EIR or negative declaration on the actual issues ripe for decision at each level of environmental review. Tiering is appropriate when the sequence of analysis is from an EIR prepared for a general plan, policy or program to an EIR or negative declaration for another plan, policy, or program of lesser scope, or to a site-specific EIR or negative declaration."

Further, Section 15152(d) of the CEQA Guidelines states:

"Where an EIR has been prepared and certified for a program, plan, policy, or ordinance consistent with the requirements of this section, any lead agency for a later project pursuant to or consistent with the program, plan, policy, or ordinance should limit the EIR or negative declaration on the later project to effects which:

- (1) Were not examined as significant effects on the environment in the prior EIR; or
- (2) Are susceptible to substantial reduction or avoidance by the choice of specific revisions in the project, by the imposition of conditions, or other means."

2. Incorporation By Reference

Incorporation by reference is a procedure for reducing the size of EIRs/MND and is most appropriate for including long, descriptive, or technical materials that provide general background information, but do not contribute directly to the specific analysis of the project itself. This procedure is particularly useful when an EIR or Negative Declaration relies on a broadly-drafted EIR for its evaluation of cumulative impacts of related projects (*Las Virgenes Homeowners Federation v. County of Los Angeles* [1986, 177 Ca.3d 300]). If an EIR or Negative Declaration relies on information from a supporting study that is available to the public, the EIR or Negative Declaration cannot be deemed unsupported by evidence or analysis (*San Francisco Ecology Center v. City and County of San Francisco* [1975, 48 Ca.3d 584, 595]). This document incorporates by reference appropriate information from the "Final Environmental Impact Report and Environmental Assessment for the "County of Imperial General Plan EIR" prepared by Brian F. Mooney Associates in 1993 and updates.

When an EIR or Negative Declaration incorporates a document by reference, the incorporation must comply with Section 15150 of the CEQA Guidelines as follows:

- The incorporated document must be available to the public or be a matter of public record (CEQA Guidelines Section 15150[a]). The General Plan EIR and updates are available, along with this document, at the County of Imperial Planning & Development Services Department, 801 Main Street, El Centro, CA 92243 Ph. (442) 265-1736.
- This document must be available for inspection by the public at an office of the lead agency (CEQA Guidelines Section 15150[b]). These documents are available at the County of Imperial Planning & Development Services Department, 801 Main Street, El Centro, CA 92243 Ph. (442) 265-1736.
- These documents must summarize the portion of the document being incorporated by reference or briefly

describe information that cannot be summarized. Furthermore, these documents must describe the relationship between the incorporated information and the analysis in the tiered documents (CEQA Guidelines Section 15150[c]). As discussed above, the tiered EIRs address the entire project site and provide background and inventory information and data which apply to the project site. Incorporated information and/or data will be cited in the appropriate sections.

- These documents must include the State identification number of the incorporated documents (CEQA Guidelines Section 15150[d]). The State Clearinghouse Number for the County of Imperial General Plan EIR is SCH #93011023.
- The material to be incorporated in this document will include general background information (CEQA Guidelines Section 15150[f]). This has been previously discussed in this document.

II. *Environmental Checklist*

1. **Project Title:** Conditional Use Permit #18-0020; J.R. Simplot Company
2. **Lead Agency:** Imperial County Planning & Development Services Department
3. **Contact person and phone number:** Joe Hernandez, Planner IV, (442) 265-1736, ext. 1748
4. **Address:** 801 Main Street, El Centro CA, 92243
5. **E-mail:** joehernandez@co.imperial.ca.us
6. **Project location:** 318 W. Harris Road, Imperial, CA
7. **Project sponsor's name and address:** J.R. Simplot Company
302 Danenberg Drive
El Centro, CA 92243
8. **General Plan designation:** Mesquite Lake Specific Plan Area
9. **Zoning:** ML-I-2 (Mesquite Lake Medium Industrial)
10. **Description of project:** The proposed project is a relocation of the fertilizer terminal facility located at 302 Danenberg Drive, El Centro, CA. The Terminal will receive, warehouse and ship fertilizer. The facility will have capacity to store 14,075 tons of up to eight products segregation of dry fertilizer, and 15,000 tons of up to four products segregations of liquid fertilizer.
11. **Surrounding land uses and setting:** The project site is surrounded by farmland to the North, East, West and South. The Southern Pacific Railroad is located just east of the site.
12. **Other public agencies whose approval is required** Planning Commission, Imperial County Public Works Department, Imperial County Environmental Health Services, Imperial County Fire Department.
13. **Have California Native American tribes traditionally and culturally affiliated with the project area requested consultation pursuant to Public Resources Code section 21080.3.1?** No, a letter has been sent out to the Quechan Indian Tribe on August 20, 2018 and no response has been received.

ENVIRONMENTAL FACTORS POTENTIALLY AFFECTED:

The environmental factors checked below would be potentially affected by this project, involving at least one impact that is a "Potentially Significant Impact" as indicated by the checklist on the following pages.

<input type="checkbox"/> Aesthetics	<input type="checkbox"/> Agriculture and Forestry Resources	<input type="checkbox"/> Air Quality
<input type="checkbox"/> Biological Resources	<input type="checkbox"/> Cultural Resources	<input type="checkbox"/> Energy
<input type="checkbox"/> Geology /Soils	<input type="checkbox"/> Greenhouse Gas Emissions	<input type="checkbox"/> Hazards & Hazardous Materials
<input type="checkbox"/> Hydrology / Water Quality	<input type="checkbox"/> Land Use / Planning	<input type="checkbox"/> Mineral Resources
<input type="checkbox"/> Noise	<input type="checkbox"/> Population / Housing	<input type="checkbox"/> Public Services
<input type="checkbox"/> Recreation	<input type="checkbox"/> Transportation	<input type="checkbox"/> Tribal Cultural Resources
<input type="checkbox"/> Utilities/Service Systems	<input type="checkbox"/> Wildfire	<input type="checkbox"/> Mandatory Findings of Significance

ENVIRONMENTAL EVALUATION COMMITTEE (EEC) DETERMINATION

After Review of the Initial Study, the Environmental Evaluation Committee has:

Found that the proposed project COULD NOT have a significant effect on the environment, and a NEGATIVE DECLARATION will be prepared.

Found that although the proposed project could have a significant effect on the environment, there will not be a significant effect in this case because revisions in the project have been made by or agreed to by the project proponent. A MITIGATED NEGATIVE DECLARATION will be prepared.

Found that the proposed project MAY have a significant effect on the environment, and an ENVIRONMENTAL IMPACT REPORT is required.

Found that the proposed project MAY have a "potentially significant impact" or "potentially significant unless mitigated" impact on the environment, but at least one effect 1) has been adequately analyzed in an earlier document pursuant to applicable legal standards, and 2) has been addressed by mitigation measures based on the earlier analysis as described on attached sheets. An ENVIRONMENTAL IMPACT REPORT is required, but it must analyze only the effects that remain to be addressed.

Found that although the proposed project could have a significant effect on the environment, because all potentially significant effects (a) have been analyzed adequately in an earlier EIR or NEGATIVE DECLARATION pursuant to applicable standards, and (b) have been avoided or mitigated pursuant to that earlier EIR or NEGATIVE DECLARATION, including revisions or mitigation measures that are imposed upon the proposed project, nothing further is required.

CALIFORNIA DEPARTMENT OF FISH AND WILDLIFE DE MINIMIS IMPACT FINDING: Yes No

<u>EEC VOTES</u>	<u>YES</u>	<u>NO</u>	<u>ABSENT</u>
PUBLIC WORKS	<input type="checkbox"/>	<input type="checkbox"/>	<input checked="" type="checkbox"/>
ENVIRONMENTAL HEALTH SVCS	<input checked="" type="checkbox"/>	<input type="checkbox"/>	<input type="checkbox"/>
OFFICE EMERGENCY SERVICES	<input checked="" type="checkbox"/>	<input type="checkbox"/>	<input type="checkbox"/>
APCD	<input checked="" type="checkbox"/>	<input type="checkbox"/>	<input type="checkbox"/>
AG	<input checked="" type="checkbox"/>	<input type="checkbox"/>	<input type="checkbox"/>
SHERIFF DEPARTMENT	<input type="checkbox"/>	<input type="checkbox"/>	<input checked="" type="checkbox"/>
ICPDS	<input checked="" type="checkbox"/>	<input type="checkbox"/>	<input type="checkbox"/>

Jim Minnick

 Jim Minnick, Director of Planning/EEC Chairman

6-13-19

 Date:

PROJECT SUMMARY

- A. Project Location:** The proposed project site is located at 318 West Harris Road, Imperial, CA, located within a portion of Tract 141 and 183, Township 14 South, Range 14 East, SBB&M. The 39.96(±)-acre parcel is located on Imperial County Assessor Parcel (APN) 040-340-043-000.
- B. Project Summary: (*Proposed Activities*):** The applicant proposes to relocate its' fertilizer warehouse/terminal where fertilizer will be received, warehoused and shipped. The project site will receive both solid and liquid fertilizers via Southern Pacific Rail Road and distribute the fertilizer via trucks. In terms of fertilizer, the facility will utilize segregation for storage purposes. Segregation is a mixture of different kinds of fertilizers in order to obtain a predicted N-P-K¹ chemical composition of solid fertilizer (Miserque, O. and E. Pirard). Therefore, the facility will have the capacity to store 14,075 tons of eight different dry/solid product segregations, and 15,000 tons of four different product segregations of liquid fertilizer. Both the liquid and solid fertilizer will be shipped via truck to recipients.

(Proposed Project Site and Circulation): The primary entrance for the facility is on Harris Road, west of the Southern Pacific Railroad tracks. This primary entrance will receive automobiles for employees and business related traffic. Traffic related activity will include inspection, employees, visitors as well as distribution trucks. Per the County Fire Marshall, a secondary access point will be required for emergency access only. This entrance shall not affect the amount of project traffic counts and will be located just west of the main entrance. Trucks will travel on SR 86 from the distribution to the end users' locations according to the proposed site plan. There will be paved roadway on site for queuing of trucks.

(Operations – Solid Fertilizer): Located at the northern portion of the facility, a proposed rail yard will be used for unloading fertilizer material. At the north/western side of the facility, a 250 TPH drag chain bucket elevator and conveyor will transfer dry fertilizer product from the train cars into Dry Bulk Warehouse 1. The conveyor will receive the product at a shallow rail receiving pit, placed below the working tract, and convey the material to the diverter located with the Dry Bulk Warehouse 1. Once fertilizer reaches this diverter, there are options; (a) the fertilizer will be diverted via a conveyor belt to be stored within Dry Bulk Warehouse 1 and (b) the fertilizer will be transported via an additional covered conveyor belt that will run perpendicular from Dry Bulk Warehouse 1 to its destination in Dry Bulk Warehouse 2 where the fertilizer will be stored. Wall separating the different types of fertilizer will be 10' high, made out of large cement blocks, and will be moveable to allow for seasonal and market demand fluctuations. The two warehouse building are identical in size: 100' x 340' with a peak height of 50'. The building will be set up to allow drive through loading. A passageway will be constructed between the buildings to allow a front end loader to travel between the buildings. Prior to operation of the drag chain bucket elevator, applicant will have filed and received permit approval.

(Liquid Fertilizer): Located on the north/eastern side of the facility will be two stations for the unloading of liquid fertilizer from train cars. All unloading stations will be spill containment area construction of curbs and concrete slabs. Five 60 Horse Power (HP) pumps will be located at these unloading stations in order to pump the liquid fertilizer to the Contained Liquid Storage Area, where the liquid fertilizer will be stored in four different storage tanks ranging in sizes. Once liquid fertilizer is ready to be transported to recipients, a 25 HP pump will pump liquid fertilizer to the loading location. This location will have four different outlets connected to the four different storage tanks. The fertilizer will be weighed by a 10' x 80' fully electronic scale located north of the primary access. The product will be weighted via electronic scale upon receipt and before shipping to clients.

(Utilities): The applicant will have an agreement with the County of Imperial to supply potable water via reservoir tanks. Due to project site location, sewage will be disposed via septic tank and leach bed field. An office and maintenance shop will be provided for employees, along with corresponding amount of parking. Outside lighting will be provided for night operations.

- C. Environmental Setting:** The project site is surrounded by farmland to the North, East West and South. The Southern Pacific Railroad is located just east of the site.
- D. Analysis:** Under the Land Use Element of the Imperial County General Plan, the project site is designated as "Specific Plan Area" and is zoned "MLI-2 (Mesquite Lake Medium Industrial Zone)" and would be considered consistent with the Imperial County's General Plan, the Mesquite Lake Specific Plan and with the County's Land Use Ordinance requirements with the approval of the Conditional Use Permit.
- E. General Plan Consistency:** The project is located within the County's General Plan designation of "Specific Plan Area" and within the Mesquite Lake Specific Plan. The Project could be considered consistent with the General Plan.

Exhibit "A"
Vicinity Map

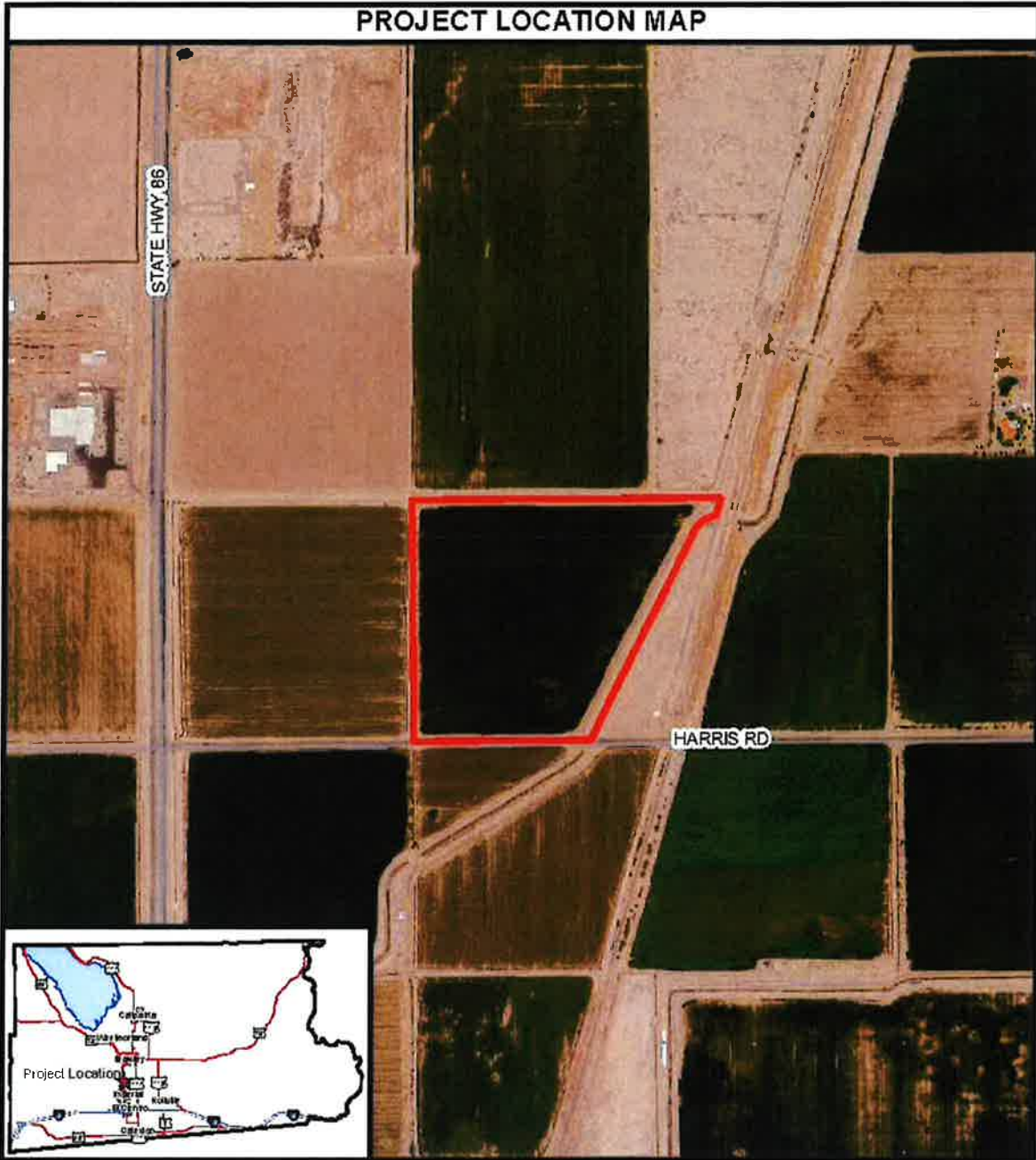

J.R. SIMPLOT COMPANY
CUP #18-0020
APN #040-340-043-000



 Parcels selection
 Centerline



Exhibit "B" Site Plan/Tract Map/etc.

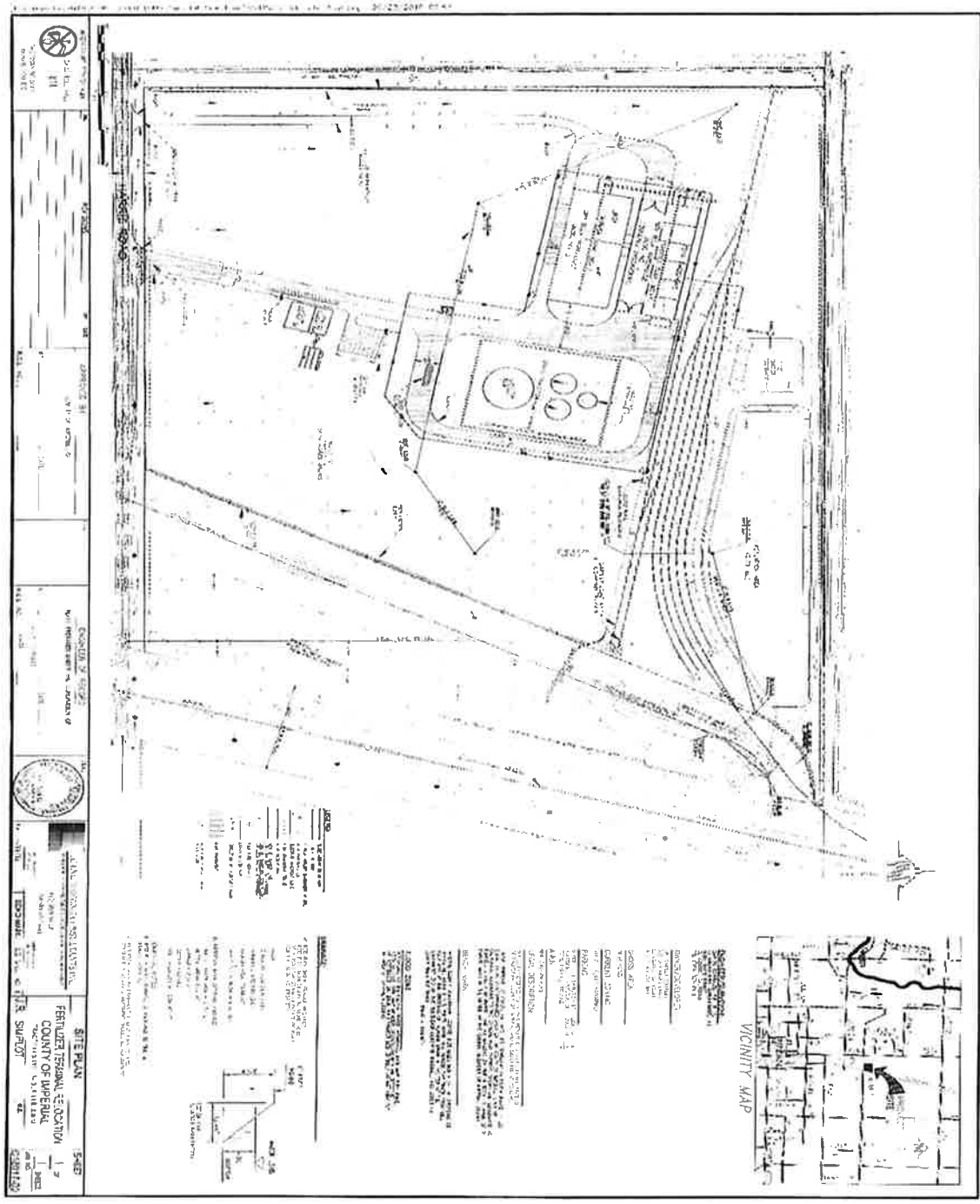

EVALUATION OF ENVIRONMENTAL IMPACTS:

- 1) A brief explanation is required for all answers except "No Impact" answers that are adequately supported by the information sources a lead agency cites in the parentheses following each question. A "No Impact" answer is adequately supported if the referenced information sources show that the impact simply does not apply to projects like the one involved (e.g., the project falls outside a fault rupture zone). A "No Impact" answer should be explained where it is based on project-specific factors as well as general standards (e.g., the project will not expose sensitive receptors to pollutants, based on a project-specific screening analysis).
- 2) All answers must take account of the whole action involved, including off-site as well as on-site, cumulative as well as project-level, indirect as well as direct, and construction as well as operational impacts.
- 3) Once the lead agency has determined that a particular physical impact may occur, then the checklist answers must indicate whether the impact is potentially significant, less than significant with mitigation, or less than significant. "Potentially Significant Impact" is appropriate if there is substantial evidence that an effect may be significant. If there are one or more "Potentially Significant Impact" entries when the determination is made, an EIR is required.
- 4) "Negative Declaration: Less Than Significant With Mitigation Incorporated" applies where the incorporation of mitigation measures has reduced an effect from "Potentially Significant Impact" to a "Less Than Significant Impact." The lead agency must describe the mitigation measures, and briefly explain how they reduce the effect to a less than significant level (mitigation measures from "Earlier Analyses," as described in (5) below, may be cross-referenced).
- 5) Earlier analyses may be used where, pursuant to the tiering, program EIR, or other CEQA process, an effect has been adequately analyzed in an earlier EIR or negative declaration. Section 15063(c)(3)(D). In this case, a brief discussion should identify the following:
 - a) Earlier Analysis Used. Identify and state where they are available for review.
 - b) Impacts Adequately Addressed. Identify which effects from the above checklist were within the scope of and adequately analyzed in an earlier document pursuant to applicable legal standards, and state whether such effects were addressed by mitigation measures based on the earlier analysis.
 - c) Mitigation Measures. For effects that are "Less than Significant with Mitigation Measures Incorporated," describe the mitigation measures which were incorporated or refined from the earlier document and the extent to which they address site-specific conditions for the project.
- 6) Lead agencies are encouraged to incorporate into the checklist references to information sources for potential impacts (e.g., general plans, zoning ordinances). Reference to a previously prepared or outside document should, where appropriate, include a reference to the page or pages where the statement is substantiated.
- 7) Supporting Information Sources: A source list should be attached, and other sources used or individuals contacted should be cited in the discussion.
- 8) This is only a suggested form, and lead agencies are free to use different formats; however, lead agencies should normally address the questions from this checklist that are relevant to a project's environmental effects in whatever format is selected.
- 9) The explanation of each issue should identify:
 - a) the significance criteria or threshold, if any, used to evaluate each question; and
 - b) the mitigation measure identified, if any, to reduce the impact to less than significance

Potentially Significant Impact (PSI)	Potentially Significant Unless Mitigation Incorporated (PSUMI)	Less Than Significant Impact (LTSI)	No Impact (NI)
--------------------------------------	--	-------------------------------------	----------------

I. AESTHETICS

Except as provided in Public Resources Code Section 21099, would the project:

- a) Have a substantial adverse effect on a scenic vista or scenic highway?
 - a) The project site is located near State Highway 86; however, this highway is not designated as a scenic highway under the Circulation and Scenic Highway Element of the Imperial County General Plan. Therefore, no impacts are expected.

Substantially damage scenic resources, including, but not limited to trees, rock outcroppings, and historic buildings within a state scenic highway?

 - b) As explained under A) above, the proposed project would not appear to substantially damage a scenic resource. Therefore, no impacts are anticipated.
- c) In non-urbanized areas, substantially degrade the existing visual character or quality of public views of the site and its surrounding? (Public views are those that are experienced from publicly accessible vantage point.) If the project is in an urbanized area, would the project conflict with applicable zoning and other regulations governing scenic quality?
 - c) The construction of the fertilizer terminal could temporarily alter the local view shed with building materials placed on-site and trucks entering and leaving the site. With implementation of the Mesquite Lake landscaping and industrial development standards. Compliance with the development standards would reduce visual impacts to level less than significant.
- d) Create a new source of substantial light or glare which would adversely affect day or nighttime views in the area?
 - d) The proposed project will include lighting on-site for the offices and include installation of power poles with light standards within the plant operation and parking area that may have an aesthetic impact on those traveling on State Route 86 from these new light sources. But the light shall be pointed downward to avoid glare onto the adjacent properties and SR 86 and to reduce nighttime glare. Lighting is not considered to be a significant, adverse aesthetic impact; and thus less than significant.

II. AGRICULTURE AND FOREST RESOURCES

In determining whether impacts to agricultural resources are significant environmental effects, lead agencies may refer to the California Agricultural Land Evaluation and Site Assessment Model (1997) prepared by the California Department of Conservation as an optional model to use in assessing impacts on agriculture and farmland. In determining whether impacts to forest resources, including timberland, are significant environmental effects, lead agencies may refer to information compiled by the California Department of Forestry and Fire Protection regarding the state's inventory of forest land, including the Forest and Range Assessment Project and the Forest Legacy Assessment project; and forest carbon measurement methodology provided in Forest Protocols adopted by the California Air Resources Board. --Would the project:

- a) Convert Prime Farmland, Unique Farmland, or Farmland of Statewide Importance (Farmland), as shown on the maps prepared pursuant to the Farmland Mapping and Monitoring Program of the California Resources Agency, to non-agricultural use?
 - a) The fertilizer terminal would be considered a farm-related business that supports the local and national agricultural-related businesses and consistent with the current land use zoned ML-I-2 (Mesquite Lake Medium Industrial), so potential impact to the County's agricultural appear to be less than significant. The County of Imperial has zoned the Mesquite Lake Specific Plan Area for future Industrial development and a Master EIR for this area was approved and certified by the Board of Supervisors in 2006. Therefore, less than significant impact would be expected.
- b) Conflict with existing zoning for agricultural use, or a Williamson Act Contract?

	Potentially Significant Impact (PSI)	Potentially Significant Unless Mitigation Incorporated (PSUMI)	Less Than Significant Impact (LTSI)	No Impact (NI)
b) The proposed project site is not under a Williamson Act land contract on the project site, so the project would not conflict with any Williamson Act land contract. Therefore, no impacts are anticipated.				
c) Conflict with existing zoning for, or cause rezoning of, forest land (as defined in Public Resources Code section 12220(g)), timberland (as defined by Public Resources Code section 4526), or timberland zoned Timberland Production (as defined by Government Code Section 51104(g))?	<input type="checkbox"/>	<input type="checkbox"/>	<input type="checkbox"/>	<input checked="" type="checkbox"/>
c) As mentioned in item a) above, the proposed project is located within the Mesquite Lake Specific Plan and will not conflict with existing zoning for, or cause rezoning of, forest land, timberland, or zoned Timberland Production. Therefore, no impacts are expected.				
d) Result in the loss of forest land or conversion of forest land to non-forest use?	<input type="checkbox"/>	<input type="checkbox"/>	<input type="checkbox"/>	<input checked="" type="checkbox"/>
d) As explained under item c) above, the proposed project will not result in the loss of forest land or conversion of forest land to non-forest use. Therefore, no impact is expected.				
e) Involve other changes in the existing environment which, due to their location or nature, could result in conversion of Farmland, to non-agricultural use or conversion of forest land to non-forest use?	<input type="checkbox"/>	<input type="checkbox"/>	<input checked="" type="checkbox"/>	<input type="checkbox"/>
e) As mentioned under item a) above, the proposed fertilizer terminal would be considered a farm-related business that supports the local and national agriculture-related and consistent with the current land use zoned ML-2 (Mesquite Lake Medium Industrial) so any potential impacts to the County's agricultural resources appear to be less than significant.				

iii. AIR QUALITY

Where available, the significance criteria established by the applicable air quality management district or air pollution control district may be relied upon to the following determinations. Would the Project:

- | | | | | |
|--|--------------------------|--------------------------|-------------------------------------|--------------------------|
| a) Conflict with or obstruct implementation of the applicable air quality plan? | <input type="checkbox"/> | <input type="checkbox"/> | <input checked="" type="checkbox"/> | <input type="checkbox"/> |
| a) The proposed project would not appear to conflict with or obstruct implementation of an applicable air quality plan. The applicant will be required to comply with the Imperial County Air Pollution Control District (ICAPCD) Regulation VIII, fugitive dust, Rule 801, and obtain a Permit to Operate, thereby reducing any impacts to a level less than significant. | | | | |
| b) Result in a cumulatively considerable net increase of any criteria pollutant for which the project region is non-attainment under an applicable federal or state ambient air quality standard? | <input type="checkbox"/> | <input type="checkbox"/> | <input checked="" type="checkbox"/> | <input type="checkbox"/> |
| b) The proposed project would not appear to violate any air quality standards or contribute to an existing or project air quality violation. The applicant will be required to obtain a Permit to Operate from the ICAPCD. The permittee must adhere to the Air District's Fugitive Dust Rules (Regulation III-Fugitive dust Rule). Therefore less than significant impacts are expected. | | | | |
| c) Expose sensitive receptors to substantial pollutants concentrations? | <input type="checkbox"/> | <input type="checkbox"/> | <input checked="" type="checkbox"/> | <input type="checkbox"/> |
| c) The proposed project would not appear to expose sensitive receptors to substantial pollutants concentration as the fertilizer is housed inside warehouses. As mentioned under item a) above, the permittee will be required to obtain a Permit to Operate from the ICAPCD. With the adherence of ICAPCD requirements, any impact would remain at a level less than significant. | | | | |
| d) Result in other emissions (such as those leading to odors adversely affecting a substantial number of people)? | <input type="checkbox"/> | <input type="checkbox"/> | <input checked="" type="checkbox"/> | <input type="checkbox"/> |
| d) The project proposed to house the fertilizer inside warehouses; therefore any odor impacts would | | | | |

Potentially Significant Impact (PSI)	Potentially Significant Unless Mitigation Incorporated (PSUMI)	Less Than Significant Impact (LTSI)	No Impact (NI)
--------------------------------------	--	-------------------------------------	----------------

appear to be less than significance.

IV. BIOLOGICAL RESOURCES *Would the project:*

- a) Have a substantial adverse effect, either directly or through habitat modifications, on any species identified as a candidate, sensitive, or special status species in local or regional plans, policies or regulations, or by the California Department of Fish and Wildlife or U.S. Fish and Wildlife Service?

a) The proposed project site is located within disturbed land (farmland). A biological survey was done by Barrett Biological Surveys and showed that no vegetation was found that would be endangered, threatened or species of concern. No vegetation onsite. Two sensitive species, the Burrowing Owl (BUOW), a California Department of Fish & Wildlife (CDFW) species of concern and two occupied burrow were found offsite on Imperial Irrigation District (IID) right of way. Implementation of mitigation measure will ensure that no adverse impacts occur to biological resources on the project site:

Mitigation Measure #1:

- BUOW shelter in place (using hay bales) and remove shelters when project is complete under supervision of qualified biologist. If passive relocation are required, qualified biologist shall consult with CDFW, Palm Desert office.
- Worker BUOW training sessions
- Monitoring when construction is within 250 feet (February–August); 160 feet (September–January) if determined necessary by qualified biologist.
- If Construction started during Migratory Bird Nesting season (February–August) a nesting bird survey should be completed one week prior to start of construction.
- With 14 days and 24 hours of start of construction, BUOW survey.

- b) Have a substantial adverse effect on any riparian habitat or other sensitive natural community identified in local or regional plans, policies, regulations, or by the California Department of Fish and Wildlife or U.S. Fish and Wildlife Service?

b) The proposed project site is farmland and will not have a substantial adverse effect on any riparian habitat or other sensitive natural community. Therefore, no impacts are anticipated.

- c) Have a substantial adverse effect on state or federally protected wetlands (including, but not limited to, marsh, vernal pool, coastal, etc.) through direct removal, filling, hydrological interruption, or other means?

c) The proposed project will not cause a substantial adverse effect on federal protected wetlands as defined by Section 404 of the Clean Water Act. Therefore, no impacts are anticipated.

- d) Interfere substantially with the movement of any resident or migratory fish or wildlife species or with established native resident or migratory wildlife corridors, or impede the use of native wildlife nursery sites?

d) The proposed project is not expected to interfere substantially with the movement of any residential or migratory fish or wildlife species or with established resident or migratory wildlife, corridors or impede the use of native wildlife nursery sites. Therefore, no impact are anticipated.

- e) Conflict with any local policies or ordinance protecting biological resource, such as a tree preservation policy or ordinance?

e) The proposed project is not expected to conflict with any local policy or ordinances protecting biological resources, such as tree preservation policy or ordinance. Therefore, no impacts are anticipated.

	Potentially Significant Impact (PSI)	Potentially Significant Unless Mitigation Incorporated (PSUMI)	Less Than Significant Impact (LTSI)	No Impact (NI)
f) Conflict with the provisions of an adopted Habitat Conservation Plan, Natural Community Conservation Plan, or other approved local, regional, or state habitat conservation plan?	<input type="checkbox"/>	<input type="checkbox"/>	<input type="checkbox"/>	<input checked="" type="checkbox"/>
f) The proposed project would not conflict with the provisions of an adopted Habitat Conservation Plan, Natural Community Conservation Plan, or other approved local, regional, or state habitat conservation plan; therefore, no impacts are expected.				

V. CULTURAL RESOURCES *Would the project:*

- | | | | | |
|--|--------------------------|--------------------------|--------------------------|-------------------------------------|
| a) Cause a substantial adverse change in the significance of a historical resource pursuant to §15064.5? | <input type="checkbox"/> | <input type="checkbox"/> | <input type="checkbox"/> | <input checked="" type="checkbox"/> |
| a) The proposed project area has been historically used for farming for many years. Pursuant to the Cultural Recourse Survey Report dated March 2019, there are no know cultural resources identified within the project area. Therefore, no impacts are expected. | | | | |
| b) Cause a substantial adverse change in the significance of an archaeological resource pursuant to §15064.5? | <input type="checkbox"/> | <input type="checkbox"/> | <input type="checkbox"/> | <input checked="" type="checkbox"/> |
| b) As mentioned under item a) above, the proposed project site has been historically used for farming and is not expected to cause a substantial adverse change in the significance of an archaeological resources. Therefore, no impacts are expected. | | | | |
| c) Disturb any human remains, including those interred outside of dedicated cemeteries? | <input type="checkbox"/> | <input type="checkbox"/> | <input type="checkbox"/> | <input checked="" type="checkbox"/> |
| c) As mentioned under item a) above, the proposed project site is located on disturbed land and is not expected to result in the disturbance of any human remains, including those interred outside of dedicated cemeteries. Therefore, no impacts are expected. | | | | |

VI. ENERGY *Would the project:*

- | | | | | |
|--|--------------------------|--------------------------|--------------------------|-------------------------------------|
| a) Result in potentially significant environmental impact due to wasteful, inefficient, or unnecessary consumption of energy resources, during project construction or operation? | <input type="checkbox"/> | <input type="checkbox"/> | <input type="checkbox"/> | <input checked="" type="checkbox"/> |
| a) The proposed project is not expected to result in potentially significant environment impact due to wasteful, inefficient, or unnecessary consumption of energy resource, either during construction or operation. Therefore, no impact are expected. | | | | |
| b) Conflict with or obstruct a state or local plan for renewable energy or energy efficiency? | <input type="checkbox"/> | <input type="checkbox"/> | <input type="checkbox"/> | <input checked="" type="checkbox"/> |
| b) The proposed project does not appear to conflict with or obstruct a state or local plan for renewal energy or energy efficiency. Therefore, no impacts are expected. | | | | |

VII. GEOLOGY AND SOILS *Would the project:*

- | | | | | |
|---|--------------------------|-------------------------------------|--------------------------|--------------------------|
| a) Directly or indirectly cause potential substantial adverse effects, including risk of loss, injury, or death involving: | <input type="checkbox"/> | <input checked="" type="checkbox"/> | <input type="checkbox"/> | <input type="checkbox"/> |
| a) A Geotechnical Report-2018 prepared by Landmark Consultants, Inc. for the proposed project and the applicant shall follow all geotechnical standards of practice for the proposed project. The project site is considered likely to be subjected to moderate to strong ground motion from earthquake in the region. The project would need to comply with the most recent California Building Code (CBC). Compliance with the CBC in additions to the following Mitigation Measure would reduce the risk to a level less than significant: | | | | |

Potentially Significant Impact (PSI)	Potentially Significant Unless Mitigation Incorporated (PSUMI)	Less Than Significant Impact (LTSI)	No Impact (NI)
--------------------------------------	--	-------------------------------------	----------------

Mitigation Measure #2:

Type C backfill must be used in wet soils and below groundwater for all buried utility pipelines. Where pipeline excavation are planned below the ground water surface, dewatering (by well points) is required to at least 24 inches below the trench bottom prior to excavation. Type A backfill may be used in the case of a dewatered trench condition in clay soils only.

- | | | | | |
|---|--------------------------|-------------------------------------|-------------------------------------|-------------------------------------|
| 1) Rupture of a known earthquake fault, as delineated on the most recent Alquist-Priolo Earthquake Fault Zoning Map issued by the State Geologist for the area or based on other substantial evidence of a known fault? Refer to Division of Mines and Geology Special Publication 42?
1) Review of the Alquist-Priolo Earthquake Fault Zone maps indicated that the nearest mapped Earthquake Fault Zone is the Imperial fault located approximately 1.2 miles east of the project site. However, as stated under item a) above, compliance with the California Building Code (CBC) and with Mitigation Measure #2, any impact would be reduced to a level less than significant. | <input type="checkbox"/> | <input checked="" type="checkbox"/> | <input type="checkbox"/> | <input type="checkbox"/> |
| 2) Strong Seismic ground shaking?
2) As mentioned under item a) above, the proposed project site could be effected by occurrence of seismic activity to some degree, but no more than the surrounding area. Adherence to the CBC would reduce potential impacts to a level less than significance. | <input type="checkbox"/> | <input type="checkbox"/> | <input checked="" type="checkbox"/> | <input type="checkbox"/> |
| 3) Seismic-related ground failure, including liquefaction and seiche/tsunami?
3) As mentioned in item a) above, the proposed project site does not appear to be located on geological units or soil that is unstable or that would become unstable as a result of seismic activity. However, the proposed project will be required to submit a soil report prior to the initial building permit to assure any structure is designed to withstand potential problems related to geology/soils/seismicity. Therefore, less than significant impact are expected. | <input type="checkbox"/> | <input type="checkbox"/> | <input checked="" type="checkbox"/> | <input type="checkbox"/> |
| 4) Landslides?
4) The proposed project site lies within a generally flat topography and therefore will be directly or indirectly affected by a landslide. Therefore no impacts are anticipated. | <input type="checkbox"/> | <input type="checkbox"/> | <input type="checkbox"/> | <input checked="" type="checkbox"/> |
| b) Result in substantial soil erosion or the loss of topsoil?
b) The proposed project site is not located within an erosion susceptible area according to the Imperial County, Seismic and Public Safety Element, Figure 3; therefore, no impacts are expected. | <input type="checkbox"/> | <input type="checkbox"/> | <input type="checkbox"/> | <input checked="" type="checkbox"/> |
| c) Be located on a geologic unit or soil that is unstable or that would become unstable as a result of the project, and potentially result in on- or off-site landslides, lateral spreading, subsidence, liquefaction or collapse?
c) The proposed project site is not located on a geological unit or soil that is unstable or would become unstable due to the expansion of the existing facility therefore, no impacts are expected. | <input type="checkbox"/> | <input type="checkbox"/> | <input type="checkbox"/> | <input checked="" type="checkbox"/> |
| d) Be located on expansive soil, as defined in the latest Uniform Building Code, creating substantial direct or indirect risk to life or property?
d) The proposed project site is not characterized by any expansive soils that would be considered environmentally significant. Potential impact deriving from expansive soils are considered negligible. Therefore, no impacts are anticipated. | <input type="checkbox"/> | <input type="checkbox"/> | <input type="checkbox"/> | <input checked="" type="checkbox"/> |
| e) Have soils incapable of adequately supporting the use of septic tanks or alternative waste water disposal systems | <input type="checkbox"/> | <input type="checkbox"/> | <input type="checkbox"/> | <input checked="" type="checkbox"/> |

	Potentially Significant Impact (PSI)	Potentially Significant Unless Mitigation Incorporated (PSUMI)	Less Than Significant Impact (LTSI)	No Impact (NI)
where sewers are not available for the disposal of waste water?				
e) The proposed project site would appear to have soils that would support the use of septic tanks. is located within the Mesquite Lake Specific Plan which includes sewer facilities. Therefore, no impacts are anticipated.				
f) Directly or indirectly destroy a unique paleontological resource or site or unique geologic feature?	<input type="checkbox"/>	<input type="checkbox"/>	<input type="checkbox"/>	<input checked="" type="checkbox"/>
f) The proposed project has been historically used for farming and is not expected to directly or indirectly destroy a unique paleontological resource or site or unique geologic feature. Therefore, no impacts are expected.				

VIII. GREENHOUSE GAS EMISSION *Would the project:*

- | | | | | |
|--|--------------------------|--------------------------|-------------------------------------|-------------------------------------|
| a) Generate greenhouse gas emissions, either directly or indirectly, that may have a significant impact on the environment? | <input type="checkbox"/> | <input type="checkbox"/> | <input checked="" type="checkbox"/> | <input type="checkbox"/> |
| a) The proposed project is for a new warehouse facility and anticipates 20 truck trips to be generated to ship fertilizer to the recipients, and a total of 7 employees to work with a shift of approximately 7 AM to 4 PM. Due to the small amount of traffic and equipment during construction and operation, the project would not appear to create substantial greenhouse gas emissions and if so, at a level less than significant. | | | | |
| b) Conflict with an applicable plan or policy or regulation adopted for the purpose of reducing the emissions of greenhouse gases? | <input type="checkbox"/> | <input type="checkbox"/> | <input type="checkbox"/> | <input checked="" type="checkbox"/> |
| b) The proposed project does not anticipate to conflict with an applicable plan, policy or regulation adopted for the purpose of reducing the emissions of greenhouse gases. Therefore, no impacts are expected. | | | | |

IX. HAZARDS AND HAZARDOUS MATERIALS *Would the project:*

- | | | | | |
|--|--------------------------|--------------------------|-------------------------------------|-------------------------------------|
| a) Create a significant hazard to the public or the environment through the routine transport, use, or disposal of hazardous materials? | <input type="checkbox"/> | <input type="checkbox"/> | <input checked="" type="checkbox"/> | <input type="checkbox"/> |
| a) The proposed project is a fertilizer facility. The fertilizer will be used for agricultural purposes and transported to agriculture fields in specially approved containers. The fertilizer produced at the Simplot facility has been used on agriculture fields for the production of food crops for many generations. No immediate hazardous condition appears to be significant in either the missing or transportation of product. However, a less than significant impact would be expected. | | | | |
| b) Create a significant hazard to the public or the environment through reasonable foreseeable upset and accident conditions involving the release of hazardous materials into the environment? | <input type="checkbox"/> | <input type="checkbox"/> | <input checked="" type="checkbox"/> | <input type="checkbox"/> |
| b) There appears to be a potential for hazard to the public through the routine transport, use or disposal of potential hazardous products. Assuming that there is compliance with all regulation regarding the collection, holding and shipping of these waste product, the impact is deemed to be less than significant. | | | | |
| c) Emit hazardous emissions or handle hazardous or acutely hazardous materials, substances, or waste within one-quarter mile of an existing or proposed school? | <input type="checkbox"/> | <input type="checkbox"/> | <input type="checkbox"/> | <input checked="" type="checkbox"/> |
| c) The proposed project site is not within ¼ mile of a school and would not pose a risk to school facilities, therefore, no impact is expected. | | | | |
| d) Be located on a site, which is included on a list of hazardous | <input type="checkbox"/> | <input type="checkbox"/> | <input type="checkbox"/> | <input checked="" type="checkbox"/> |

	Potentially Significant Impact (PSI)	Potentially Significant Unless Mitigation Incorporated (PSUMI)	Less Than Significant Impact (LTSI)	No Impact (NI)
materials sites compiled pursuant to Government Code Section 65962.5 and, as a result, would it create a significant hazard to the public or the environment? d) The proposed project site is not located on a site included on a list of hazardous material sites; therefore, no impact is expected.				
e) For a project located within an airport land use plan or, where such a plan has not been adopted, within two miles of a public airport or public use airport, would the project result in a safety hazard or excessive noise for people residing or working in the project area? e) The proposed project site is not located within an Airport Land Use Compatibility Area and would appear not to have any significant impact to people residing or working in the project area. Therefore, no impact is expected.	<input type="checkbox"/>	<input type="checkbox"/>	<input type="checkbox"/>	<input checked="" type="checkbox"/>
f) Impair implementation of or physically interfere with an adopted emergency response plan or emergency evacuation plan? f) The proposed project site does not appear to interfere with an adopted emergency response plan or emergency evacuation plan, therefore, no impact is expected.	<input type="checkbox"/>	<input type="checkbox"/>	<input type="checkbox"/>	<input checked="" type="checkbox"/>
g) Expose people or structures, either directly or indirectly, to a significant risk of loss, injury or death involving wildland fires? g) The proposed project site is not located in an area susceptible to wildland fires, therefore, no impact is expected.	<input type="checkbox"/>	<input type="checkbox"/>	<input type="checkbox"/>	<input checked="" type="checkbox"/>

X. HYDROLOGY AND WATER QUALITY *Would the project:*

a) Violate any water quality standards or waste discharge requirements or otherwise substantially degrade surface or ground water quality? a) The proposed project will not appear to violate water quality standards or waste discharge requirements for any installation of a septic system for any structure generating domestic wastewater will be require and permitted by the Environmental Health Services. No discharge of any industrial or process wastewater is proposed, but if the applicant commences to discharge any industrial or processed wastewater, the applicant will need to work with the Regional Water Quality control Board for permitting and discharge. Therefore, less than significant impacts are anticipated.	<input type="checkbox"/>	<input type="checkbox"/>	<input checked="" type="checkbox"/>	<input type="checkbox"/>
b) Substantially decrease groundwater supplies or interfere substantially with groundwater recharge such that the project may impede sustainable groundwater management of the basin? b) The proposed project will not affect or deplete groundwater supplies or interfere with groundwater recharge. Therefore, no impacts are expected.	<input type="checkbox"/>	<input type="checkbox"/>	<input type="checkbox"/>	<input checked="" type="checkbox"/>
c) Substantially alter the existing drainage pattern of the site or area, including through the alteration of the course of a stream or river or through the addition of impervious surfaces, in a manner which would: c) The proposed project will not substantially alter the existing drainage pattern of the site or area, resulting in substantial erosion or siltation on- or off-site. Prior to any development, the applicant will be required to submit a Drainage and Grading Plan to the Department of Public Works for review and approval which will also include Employment of appropriate Storm Water Best Management Practices. Therefore, less than significant impacts are expected.	<input type="checkbox"/>	<input type="checkbox"/>	<input checked="" type="checkbox"/>	<input type="checkbox"/>

	Potentially Significant Impact (PSI)	Potentially Significant Unless Mitigation Incorporated (PSUMI)	Less Than Significant Impact (LTSI)	No Impact (NI)
(i) result in substantial erosion or siltation on- or off-site; (i) As mentioned under Geology & Soils b) above, the project is not located within an erosion susceptible area. Therefore, no impacts are anticipated.	<input type="checkbox"/>	<input type="checkbox"/>	<input type="checkbox"/>	<input checked="" type="checkbox"/>
(ii) substantially increase the rate or amount of surface runoff in a manner which would result in flooding on- or offsite; (ii) The proposed project site is not expected to increase the rate or amount of surface runoff which would result in flooding on- off-site. Imperial County Public Works will require a Drainage/Grading Plan/Study. Through the implementation of the plan, the impacts would be less than significant.	<input type="checkbox"/>	<input type="checkbox"/>	<input checked="" type="checkbox"/>	<input type="checkbox"/>
(iii) create or contribute runoff water which would exceed the capacity of existing or planned stormwater drainage systems or provide substantial additional sources of polluted runoff; or; (iii) The Proposed project is not expected to create or contribute runoff water which would exceed the capacity of existing stormwater drainage system or provide substantial additional source of polluted runoff. Imperial County Public Works will required a Drainage/Grading Plan Study. Through the implementation of the plan, the impacts would appear to be less than significant.	<input type="checkbox"/>	<input type="checkbox"/>	<input checked="" type="checkbox"/>	<input type="checkbox"/>
(iv) impede or redirect flood flows? (iv) The proposed project does not appear to impede or redirect flood flow. The project site is located within Zone X per Flood Insurance Rate Map, Panel #06025C1375C. Therefore, no impact are expected.	<input type="checkbox"/>	<input type="checkbox"/>	<input type="checkbox"/>	<input checked="" type="checkbox"/>
d) In flood hazard, tsunami, or seiche zones, risk release of pollutants due to project inundation? d) As mentioned under item iv) above, the project site lies within Zone X and is not located in a flood hazard, tsunami, or seiche risk. No impacts are expected.	<input type="checkbox"/>	<input type="checkbox"/>	<input type="checkbox"/>	<input checked="" type="checkbox"/>
e) Conflict with or obstruct implementation of a water quality control plan or sustainable groundwater management plan? e) The proposed project does not appear to conflict or obstruct implementation of a water quality control plan or a sustainable groundwater management plan. No impacts are expected.	<input type="checkbox"/>	<input type="checkbox"/>	<input type="checkbox"/>	<input checked="" type="checkbox"/>

XI. LAND USE AND PLANNING *Would the project:*

- | | | | | |
|---|--------------------------|--------------------------|-------------------------------------|-------------------------------------|
| a) Physically divide an established community?
a) The proposed project will not physically divide an established community; therefore, no impact is expected. | <input type="checkbox"/> | <input type="checkbox"/> | <input type="checkbox"/> | <input checked="" type="checkbox"/> |
| b) Cause a significant environmental impact due to a conflict with any land use plan, policy, or regulation adopted for the purpose of avoiding or mitigating an environmental effect?
b) Under the Land Use Element of the Imperial County General Plan, the project site is designated as "Specific Planned Area and lies within the Mesquite Lake Specific Plan." It is classified as MLI-2 (Mesquite Lake Medium Industrial), and would not conflict with the General Plan or Land Use Ordinance, since it is a permitted use with an approved conditional use permit. Therefore, less than significant impacts are expected. | <input type="checkbox"/> | <input type="checkbox"/> | <input checked="" type="checkbox"/> | <input type="checkbox"/> |

Potentially Significant Impact (PSI)	Potentially Significant Unless Mitigation Incorporated (PSUMI)	Less Than Significant Impact (LTSI)	No Impact (NI)
--------------------------------------	--	-------------------------------------	----------------

XII. MINERAL RESOURCES *Would the project:*

- a) Result in the loss of availability of a known mineral resource that would be of value to the region and the residents of the state?
- a) The proposed project will not remove mineral resources on-site; therefore, no impact is expected.
- b) Result in the loss of availability of a locally-important mineral resource recovery site delineated on a local general plan, specific plan or other land use plan?
- b) The proposed project will not result in the loss of a locally-important mineral resources recovery site; therefore, no impact is expected.

XIII. NOISE *Would the project result in:*

- a) Generation of a substantial temporary or permanent increase in ambient noise levels in the vicinity of the project in excess of standards established in the local general plan or noise ordinance, or applicable standards of other agencies?
- a) The proposed project is not expected to expose persons to or generation of noise levels in excess of standards established in the local general plan or noise ordinance, or applicable standards of other agencies. The uses permitted under the Mesquite Lake Industrial zoning are uses typical of a "Medium Industrial" MLI2 zone area that this project site is located in and any such noise levels associated with those uses are deemed to be acceptable by the their zone classification and listed permitted uses. Therefore less than significant impacts are expected.
- b) Generation of excessive groundborne vibration or groundborne noise levels?
- b) The proposed project is not expected to generate of excessive grounborne vibration or groundborne noise levels. Less than significant impacts are expected.
- c) For a project located within the vicinity of a private airstrip or an airport land use plan or where such a plan has not been adopted, within two miles of a public airport or public use airport, would the project expose people residing or working in the project area to excessive noise levels?
- c) The proposed project is not located within the vicinity of a private airstrip or an airport land use plan or a public airport or public use airport which would exposed people residing or working in the project with excess noise level. Therefore, no impacts are expected.

XIV. POPULATION AND HOUSING *Would the project:*

- a) Induce substantial unplanned population growth in an area, either directly (for example, by proposing new homes and business) or indirectly (for example, through extension of roads or other infrastructure)?
- a) The purpose of the project is to relocate an existing fertilizer warehouse/terminal and would not induce substantial population growth in the area either directly or indirectly. While there would be impacts, the impacts would appear to be less than significant.
- b) Displace substantial numbers of existing people or housing, necessitating the construction of replacement housing elsewhere?

Potentially Significant Impact (PSI)	Potentially Significant Unless Mitigation Incorporated (PSUMI)	Less Than Significant Impact (LTSI)	No Impact (NI)
---	--	--	-------------------

b) The proposed project is not expected to displace substantial numbers of exiting housing, necessitating the construction of replacement housing elsewhere; therefore, no impact is expected.

XV. PUBLIC SERVICES

a) Would the project result in substantial adverse physical impacts associated with the provision of new or physically altered governmental facilities, need for new or physically altered governmental facilities, the construction of which could cause significant environmental impacts, in order to maintain acceptable service ratios, response times or other performance objectives for any of the public services:

<input type="checkbox"/>	<input type="checkbox"/>	<input checked="" type="checkbox"/>	<input type="checkbox"/>
--------------------------	--------------------------	-------------------------------------	--------------------------

(a) The proposed appears to have a less than significant impact upon both fire and police protection in order to respond to any emergency situations, the project site location is near to State Route 86 and this should make any response time quicker and more accessible. The project shall also be reviewed by the applicable Police and Fire response agencies and conditioned for the provision of the necessary public series that they provide. However, less than significant impacts are expected.

1) Fire Protection?

1) The proposed project is not expected to result in substantial impacts on fire protection; however, any new impact would be less than significant.

2) Police Protection?

2) The proposed project is not expected to result in substantial impacts on police protection; any new impact would be less than significant.

3) Schools?

3) The proposed project is not expected to result in impacts to schools.

4) Parks?

4) The proposed project will not result in impacts to parks; therefore, no impacts are expected.

5) Other Public Facilities?

5) As explained in a) above, the proposed project is not expected to result in impacts to other facilities. Less than significant impact would be expected.

XVI. RECREATION

a) Would the project increase the use of the existing neighborhood and regional parks or other recreational facilities such that substantial physical deterioration of the facility would occur or be accelerated?

a) The proposed project site is in an industrial designated area and would not appear to increase the use of the existing neighborhood and regional parks or other recreational facilities; therefore, no impacts are expected.

b) Does the project include recreational facilities or require the construction or expansion of recreational facilities which might have an adverse effect on the environment?

b) The proposed project is in an industrial designated area and does not include recreational facilities or require the construction or expansion of recreation facilities which might have an adverse effect on the environment. Therefore, no impacts are expected.

Potentially Significant Impact (PSI)	Potentially Significant Unless Mitigation Incorporated (PSUMI)	Less Than Significant Impact (LTSI)	No Impact (NI)
--------------------------------------	--	-------------------------------------	----------------

XVII. TRANSPORTATION *Would the project:*

- a) Conflict with a program plan, ordinance or policy addressing the circulation system, including transit, roadway, bicycle and pedestrian facilities?
- a) The proposed project will result in an increase in traffic to and from the project site on local roads. The imperial County Public Works Department has reviewed the proposed project and will require an encroachment permit for work performed within County right-of-way. Per the updated traffic dated April 16, 2019, no significant impacts would occur due to project, and no mitigation measures are not necessary. Therefore, no impact are expected.
- b) Would the project conflict or be inconsistent with the CEQA Guidelines section 15064.3, subdivision (b)?
- b) The proposed project does not appear to conflict or be inconsistent with CEQA Guidelines, section 15064.3(b). There are no transit stops within a one-half mile of the proposed project site; however, any road improvement shall be made to the Imperial County Public Works Department requirements. Less that significant impacts are anticipated.
- c) Substantially increases hazards due to a geometric design feature (e.g., sharp curves or dangerous intersections) or incompatible uses (e.g., farm equipment)?
- c) The proposed project does not appear to substantially increase hazards due to design features or incompatible uses. Additionally, Imperial County Public Works Department will require an encroachment permit which will address the ingress/egress from Harris Road. Therefore, any impact would appear to be less than significant.
- d) Result in inadequate emergency access?
- d) The proposed project would not result in inadequate emergency access; therefore, no impact is expected.

XVIII. TRIBAL CULTURAL RESOURCES

- a) Would the project cause a substantial adverse change in the significance of a tribal cultural resource, defined in Public Resources Code Section 21074 as either a site, feature, place, cultural landscape that is geographically defined in terms of the size and scope of the landscape, sacred place or object with cultural value to a California Native American tribe, and that is:
- a) The project would not cause an adverse change in the significance of a tribal cultural resource, therefore, any impacts are considered less than significant. Based on Figure 6 Known Areas of Native American Sensitivity of the Conservation and Open Space Element of the Imperial County General Plan, the project site is not located with any sensitive area. Additionally, a letter was sent to the Quechan Indian Tribe and on August 20, 2018 and no response has been received. However, no impacts are expected.
- (i) Listed or eligible for listing in the California Register of Historical Resources, or in a local register of historical resources as define in Public Resources Code Section 5020.1(k), or
- (i) The proposed project had been historically farmed and is currently vacant and would not be listed or eligible for listing in the California Register of Historical Resources. Therefore, no impacts are expected.

	Potentially Significant Impact (PSI)	Potentially Significant Unless Mitigation Incorporated (PSUMI)	Less Than Significant Impact (LTSI)	No Impact (NI)
(ii) A resource determined by the lead agency, in its discretion and supported by substantial evidence, to be significant pursuant to criteria set forth in subdivision (c) of Public Resources Code Section 5024.1. In applying the criteria set forth in subdivision (c) of Public Resource Code Section 5024.1, the lead agency shall consider the significance of the resource to a California Native American Tribe.	<input type="checkbox"/>	<input type="checkbox"/>	<input type="checkbox"/>	<input checked="" type="checkbox"/>
(ii) As mentioned in a) above, a letter was sent to the Quechan Indian Tribe and on August 20, 2018 the sent an email stating they have no comments. However, no impacts are expected.				

XIX. UTILITIES AND SERVICE SYSTEMS *Would the project:*

- a) Require or result in the relocation or construction of new or expanded water, wastewater treatment or stormwater drainage, electric power, natural gas, or telecommunications facilities, the construction of which could cause significant environmental effects?
- a) The proposed project is not expected to require or result in the relocation or construction of new or expand water, wastewater treatment or stormwater drainage, electrical power, natural gas, or telecommunications facility. Therefore, no impacts are expected.**
- b) Have sufficient water supplies available to serve the project from existing and reasonably foreseeable future development during normal, dry and multiple dry years?
- b) The proposed project is not expected to exceed the capacity of the current services provider and no new or expanded entitlements are needed. Therefore, no impacts are anticipated.**
- c) Result in a determination by the wastewater treatment provider which serves or may serve the project that it has adequate capacity to serve the project's projected demand in addition to the provider's existing commitments?
- c) In Mesquite Lake Specific Plan EIR, the County of Imperial and its Departments shall review all final maps, grading plans, building permits, use permits, and other applications for development of property within the Specific Plan and shall determine whether adequate public service improvements are provided or planned to accomplish the long-term land use objectives of the Mesquite Lake Specific Plan. While individual development may be allowed to proceed, the County shall determine the need for appropriate fair-share contributions, by fee or facility construction, to be required of any applicant. In addition, the County may require development agreements from project applicants to ensure participation in the formation and funding of a CFD or other public agency to accomplish the construction and operation of the required infrastructure improvements identified in the Specific Plan. Development of the proposed project would require provision of adequate water flows to provide fire protection services to the project site. Sewer and water shall be constructed and maintained to County standards.**

Mitigation Measure #3:

Prior to issuance of any building permit for any new building within the project, development impact mitigation fees as provided by the County Municipal Code. In addition, the building permit applicant shall provide evidence to the satisfaction of the Planning and Development Services Director and Fire Chief that an adequate system of water storage and pumping for fire protection exists for the project or will be constructed and available for use upon completion of the building. This shall include an agreement between the applicant and property owner with the County Fire Department that a specified minimum volume of water in the storage pond will be maintained at all times. All facilities required for fire protection services shall be installed and in working order prior to issuance of a certificate of occupancy for the

	Potentially Significant Impact (PSI)	Potentially Significant Unless Mitigation Incorporated (PSUMI)	Less Than Significant Impact (LTSI)	No Impact (NI)
building.				
d) Generate solid waste in excess of State or local standards, or in excess of the capacity of local infrastructure, or otherwise impair the attainment of solid waste reduction goals? d) The proposed project would appear to generate during construction and operational phases; however, applicant/contractor would require that an approved solid waste hauler be contracted for waste disposal. Therefore, a less than significant impact would be expected.	<input type="checkbox"/>	<input type="checkbox"/>	<input checked="" type="checkbox"/>	<input type="checkbox"/>
e) Comply with federal, state, and local management and reduction statutes and regulations related to solid waste? e) The proposed project shall comply with federal, state and local statutes and regulations related to solid waste. Therefore, less than significant impacts would be expected.	<input type="checkbox"/>	<input type="checkbox"/>	<input checked="" type="checkbox"/>	<input type="checkbox"/>

XX. WILDFIRE

If located in or near state responsibility areas or lands classified as very high fire hazard severity zones, would the Project:

- | | | | | |
|--|--------------------------|--------------------------|--------------------------|-------------------------------------|
| a) Substantially impair an adopted emergency response plan or emergency evacuation plan?
a) The proposed project is not expected to substantially impair an adopted emergency response plan or emergency evacuation plan. No impacts are anticipated. | <input type="checkbox"/> | <input type="checkbox"/> | <input type="checkbox"/> | <input checked="" type="checkbox"/> |
| b) Due to slope, prevailing winds, and other factors, exacerbate wildfire risks, and thereby expose project occupants to pollutant concentrations from a wildfire or the uncontrolled spread of a wildfire?
b) The proposed project is in a flat topographical area and not within a wildfire area. Therefore, no impacts are anticipated. | <input type="checkbox"/> | <input type="checkbox"/> | <input type="checkbox"/> | <input checked="" type="checkbox"/> |
| c) Require the installation or maintenance of associated infrastructure (such as roads, fuel breaks, emergency water sources, power lines or other utilities) that may exacerbate fire risk or that may result in temporary or ongoing impacts to the environment?
c) The project is not located within a very high fire hazard severity zone and will not require infrastructure that may exacerbate fire risk. Therefore, no impacts are anticipated. | <input type="checkbox"/> | <input type="checkbox"/> | <input type="checkbox"/> | <input checked="" type="checkbox"/> |
| d) Expose people or structures to significant risks, including downslope or downstream flooding or landslides, as a result of runoff, post-fire slope instability, or drainage changes?
d) The project area is in a flat topographical area and would not expose people or structures to risk significant risks due to flooding or landslide as a result of runoff, post-fire slope instability or drainage changes. Therefore, no impacts are anticipated. | <input type="checkbox"/> | <input type="checkbox"/> | <input type="checkbox"/> | <input checked="" type="checkbox"/> |

Note: Authority cited: Sections 21083 and 21083.05, Public Resources Code. Reference: Section 65088.4, Gov. Code; Sections 21080(c), 21080.1, 21080.3, 21083, 21083.05, 21083.3, 21093, 21094, 21095, and 21151, Public Resources Code; Sundstrom v. County of Mendocino, (1988) 202 Cal.App.3d 296; Leonoff v. Monterey Board of Supervisors, (1990) 222 Cal.App.3d 1337; Eureka Citizens for Responsible Govt. v. City of Eureka (2007) 147 Cal.App.4th 357; Protect the Historic Amador Waterways v. Amador Water Agency (2004) 116 Cal.App.4th at 1109; San Franciscans Upholding the Downtown Plan v. City and County of San Francisco (2002) 102 Cal.App.4th 658.

Revised 2009- CEQA
Revised 2011- ICPDS

Potentially Significant Impact (PSI)	Potentially Significant Unless Mitigation Incorporated (PSUMI)	Less Than Significant Impact (LTSI)	No Impact (NI)
--------------------------------------	--	-------------------------------------	----------------

Revised 2016 – ICPDS
 Revised 2017 – ICPDS
 Revised 2018 – ICPDS

Potentially Significant Impact (PSI)	Potentially Significant Unless Mitigation Incorporated (PSUMI)	Less Than Significant Impact (LTSI)	No Impact (NI)
--------------------------------------	--	-------------------------------------	----------------

SECTION 3

III. MANDATORY FINDINGS OF SIGNIFICANCE

The following are Mandatory Findings of Significance in accordance with Section 15065 of the CEQA Guidelines.

- | | | | | |
|--|--------------------------|-------------------------------------|-------------------------------------|--------------------------|
| <p>a) Does the project have the potential to substantially degrade the quality of the environment, substantially reduce the habitat of a fish or wildlife species, cause a fish or wildlife population to drop below self-sustaining levels, threaten to eliminate a plant or animal community, substantially reduce the number or restrict the range of a rare or endangered plant or animal, eliminate tribal cultural resources or eliminate important examples of the major periods of California history or prehistory?</p> | <input type="checkbox"/> | <input checked="" type="checkbox"/> | <input type="checkbox"/> | <input type="checkbox"/> |
| <p>b) Does the project have impacts that are individually limited, but cumulatively considerable? ("Cumulatively considerable" means that the incremental effects of a project are considerable when viewed in connection with the effects of past projects, the effects of other current projects, and the effects of probable future projects.)</p> | <input type="checkbox"/> | <input type="checkbox"/> | <input checked="" type="checkbox"/> | <input type="checkbox"/> |
| <p>c) Does the project have environmental effects, which will cause substantial adverse effects on human beings, either directly or indirectly?</p> | <input type="checkbox"/> | <input type="checkbox"/> | <input checked="" type="checkbox"/> | <input type="checkbox"/> |

IV. PERSONS AND ORGANIZATIONS CONSULTED

This section identifies those persons who prepared or contributed to preparation of this document. This section is prepared in accordance with Section 15129 of the CEQA Guidelines.

A. COUNTY OF IMPERIAL

- Jim Minnick, Director of Planning & Development Services
- Michael Abraham, AICP, Assistant Director of Planning & Development Services
- Joe Hernandez, Project Planner
- Imperial County Air Pollution Control District
- Department of Public Works
- Fire Department
- Ag Commissioner
- Environmental Health Services
- Sheriff's Office

B. OTHER AGENCIES/ORGANIZATIONS

- Imperial Irrigation District

(Written or oral comments received on the checklist prior to circulation)

V. REFERENCES

1. "County of Imperial General Plan EIR", prepared by Brian F. Mooney & Associates in 1993; and, as Amended by County in 1996, 1998, 2001, 2003, 2006 & 2008, 2015, 2016.
2. County of Imperial Land Use Ordinance
3. Williamson Act map created in 2012 by the Imperial County Planning & Development Service Department for the Imperial County Board of Supervisors; Order #10a
4. Imperial County Air Pollution Control District's Air Quality Handbook
5. State of California, Aquist-Priolo Earthquake Fault Zone Maps, Revised January 1, 1980, Special Studies Map
6. U.S. Department of Homeland Security, Federal Emergency Management Flood Insurance Rate Maps, effected September 26, 2008.
7. County of Imperial Airport Land Use Compatibility Plan

VI. NEGATIVE DECLARATION – County of Imperial

The following Negative Declaration is being circulated for public review in accordance with the California Environmental Quality Act Section 21091 and 21092 of the Public Resources Code.

Project Name: Conditional Use Permit #18-0020.

Project Applicant: J.R. Simplot Company

Project Location: The proposed project site is located at 318 West Harris Road, Imperial, CA, located within a portion of Tract 141 and 183, Township 14 South, Range 14 East, SBB&M. The ±39.96 acre parcel is located on Assessor Parcel Number 040-340-043-000.

Description of Project: The proposed project is a relocation of the fertilizer terminal facility located at 302 Danenberg Drive, El Centro, CA. The Terminal will receive, warehouse and ship fertilizer. The facility will have capacity to store 14,075 tons of up to eight products segregation of dry fertilizer, and 15,000 tons of up to four products segregations of liquid fertilizer.

VII. FINDINGS

This is to advise that the County of Imperial, acting as the lead agency, has conducted an Initial Study to determine if the project may have a significant effect on the environmental and is proposing this Negative Declaration based upon the following findings:

The Initial Study shows that there is no substantial evidence that the project may have a significant effect on the environment and a NEGATIVE DECLARATION will be prepared.

The Initial Study identifies potentially significant effects but:

- (1) Proposals made or agreed to by the applicant before this proposed Mitigated Negative Declaration was released for public review would avoid the effects or mitigate the effects to a point where clearly no significant effects would occur.
- (2) There is no substantial evidence before the agency that the project may have a significant effect on the environment.
- (3) Mitigation measures are required to ensure all potentially significant impacts are reduced to levels of insignificance.

A NEGATIVE DECLARATION will be prepared.

If adopted, the Negative Declaration means that an Environmental Impact Report will not be required. Reasons to support this finding are included in the attached Initial Study. The project file and all related documents are available for review at the County of Imperial, Planning & Development Services Department, 801 Main Street, El Centro, CA 92243 (442) 265-1736.

NOTICE

The public is invited to comment on the proposed Negative Declaration during the review period.

6-13-19 
Date of Determination Jim Minnick, Director of Planning & Development Services

The Applicant hereby acknowledges and accepts the results of the Environmental Evaluation Committee (EEC) and hereby agrees to implement all Mitigation Measures, if applicable, as outlined in the MMRP.

 6-13-2019
Applicant Signature Date

SECTION 4

VI. NEGATIVE DECLARATION – County of Imperial

The following Negative Declaration is being circulated for public review in accordance with the California Environmental Quality Act Section 21091 and 21092 of the Public Resources Code.

Project Name: Conditional Use Permit #18-0020.

Project Applicant: J.R. Simplot Company

Project Location: The proposed project site is located at 318 West Harris Road, Imperial, CA, located within a portion of Tract 141 and 183, Township 14 South, Range 14 East, SBB&M. The ±39.96 acre parcel is located on Assessor Parcel Number 040-340-043-000.

Description of Project: The proposed project is a relocation of the fertilizer terminal facility located at 302 Danenberg Drive, El Centro, CA. The Terminal will receive, warehouse and ship fertilizer. The facility will have capacity to store 14,075 tons of up to eight products segregation of dry fertilizer, and 15,000 tons of up to four products segregations of liquid fertilizer.

VIII. RESPONSE TO COMMENTS

(ATTACH DOCUMENTS, IF ANY, HERE)

S:\APN\040\340\043\CUP #18-0020\EEC Pkg\Revised IS Form.docx

AIR POLLUTION CONTROL DISTRICT



November 13, 2018

RECEIVED

NOV 13 2018

IMPERIAL COUNTY
PLANNING & DEVELOPMENT SERVICES

Jim Minnick
Planning & Development Services Director
801 Main Street
El Centro, CA 92243

SUBJECT: Conditional Use Permit #18-0020 – J. R. Simplot Company

Dear Mr. Minnick,

The Imperial County Air Pollution Control District (Air District) has reviewed the Recirculation of Conditional Use Permit #18-0020 for the J.R. Simplot Company and is concerned over the lack of potential important information. Based on the submitted information, the J.R. Simplot Company is proposing to relocate their fertilizer terminal facility from 302 Danenberg Drive in El Centro to 318 West Harris Road in Imperial. The terminal will receive, store and ship both solid and liquid fertilizer via the Southern Pacific Rail Road, and distribute the fertilizer via trucks. Although the included information summarizes the general operations it does not seem to properly disclose the potential issues with handling and transportation. The Air District has questions of interest related to the following:

- 1) Unloading of fertilizer material using a 250 TPH drag chain bucket elevator and conveyor —what will be used to power the machinery?
- 2) What is a diverter?
- 3) What element of the Dry Bulk Warehouse 1 and 2 make them distinctly different from each other? Both indicate they are storage.
- 4) Are dry fertilizer storage and handling requirements different from liquid handling and storage? If so, why? Are there pressure considerations and mixtures that are considered in violation of current regulations?
- 5) How will the potential for fires be addressed?
- 6) How are leaks addressed?

Within the last five years the USEPA has promulgated rulemaking which included ammonia as a precursor to PM2.5. Any leakage of ammonia during the handling, storage, or transportation stages could result in unintended consequences to air quality. The Occupational Safety and Health

Administration has published a guide titled "Chemical Advisory: Safe Storage, Handling, and Management of Solid Ammonium Nitrate Prills" which outlines safety guidelines for certain hazardous materials. An example can be found on page 5 of the publication under "Hazard Reduction," and on page 14 under "Information Resources, Codes and Standards" section. The Air District respectfully requests further information on the proposed handling, storage, and transportation procedures of the fertilizer, both dry and liquid, to be used at the Fertilizer Terminal Facility explaining how the facility intends to meet safety storage and handling guidelines.

The ICAPCD urges the applicant to contact the Engineering and Permitting Division of the Air District to further discuss the use of pumps outlined in the CUP to determine the proper permitting requirements, and to determine whether any equipment to be used during construction or operations will require an Authority to Construct/Permit to Operate. Finally, the Air District reminds the applicant that all construction and or earthmoving activities are required to comply with Regulation VIII Fugitive Dust Rules. Air District Rules and Regulations can be found on our website at www.co.imperial.ca.us/AirPollution under the "Planning" tab. Should the applicant have any further questions, please contact our office at (442) 265-1800.

Sincerely,



Curtis Blondell
ICAPCD Environmental Coordinator



AUGUSTINE BAND OF CAHUILLA INDIANS

PO Box 846 84-481 Avenue 54 Coachella CA 92236

Telephone: (760) 398-4722

Fax (760) 369-7161

Tribal Chairperson: Amanda Vance

Tribal Vice-Chairperson: William Vance

Tribal Secretary: Victoria Martin

RECEIVED

November 5, 2018

NOV 13 2018

Joe Hernandez
Imperial County Planning & Development Services
801 Main Street
El Centro, CA 92243

IMPERIAL COUNTY
PLANNING & DEVELOPMENT SERVICES

Re: Project ID: Conditional Use Permit #18-0020 (Recirculation)

Project Location: 318 West Harris Road, Imperial, CA; APN 040-340-043-000

Dear Mr. Hernandez-

Thank you for the opportunity to offer input concerning the development of the above-identified project. We appreciate your sensitivity to the cultural resources that may be impacted by your project, and the importance of these cultural resources to the Native American peoples that have occupied the land surrounding the area of your project for thousands of years. Unfortunately, increased development and lack of sensitivity to cultural resources has resulted in many significant cultural resources being destroyed or substantially altered and impacted. Your invitation to consult on this project is greatly appreciated.

At this time we are unaware of specific cultural resources that may be affected by the proposed project. We encourage you to contact other Native American Tribes and individuals within the immediate vicinity of the project site that may have specific information concerning cultural resources that may be located in the area. We also encourage you to contract with a monitor who is qualified in Native American cultural resources identification and who is able to be present on-site full-time during the pre-construction and construction phase of the project. Please notify us immediately should you discover any cultural resources during the development of this project.

Very truly yours,

Victoria Martin
Tribal Secretary

EEC ORIGINAL PKG

DEPARTMENT OF TRANSPORTATION

DISTRICT 11
4050 TAYLOR STREET, MS-240
SAN DIEGO, CA 92110
PHONE (619) 688-6960
FAX (619) 688-4299
TTY 711
www.dot.ca.gov



*Making Conservation
a California Way of Life.*

August 20, 2018

11-IMP-86
PM 13.32
Simplot Fertilizer Terminal Facility
CUP

Mr. Joe Hernandez, Planner III
Imperial County Planning and Development Services Dept.
801 Main Street
El Centro, CA 92243

Dear Mr. Hernandez:

Thank you for including the California Department of Transportation (Caltrans) in the Conditional Use Permit (CUP) #18-0020 review for the J.R. Simplot Company Fertilizer Terminal Facility. The proposed project is located near State Route 86 (SR-86) and West Harris Road. The mission of Caltrans is to provide a safe, sustainable, integrated and efficient transportation system to enhance California's economy and livability. The Local Development-Intergovernmental Review (LD-IGR) Program reviews land use projects and plans to ensure consistency with our mission and state planning priorities.

Caltrans has the following comments:

Please provide the Traffic Study when available for review.

If you have any questions, please contact Mark McCumsey at (619) 688-6802 or by email at mark.mccumsey@dot.ca.gov

Sincerely,

A handwritten signature in blue ink, appearing to read 'J. Armstrong'.

JACOB ARMSTRONG, Branch Chief
Local Development and Intergovernmental Review Branch

*"Provide a safe, sustainable, integrated and efficient transportation system
to enhance California's economy and livability"*

EEC ORIGINAL PKG



Campo Band of Mission Indians

Chairman Ralph Goff
Vice-Chairman Harry P. Cuero Jr.
Secretary Kerm Shipp
Treasurer Marcus Cuero
Committee Brian Connolly Sr.
Committee Steven M. Cuero
Committee Benjamin Dyche

October 24, 2018

Joe Hernandez

Planner IV

Imperial County Planning and Development Services

801 Main Street

El Centro, CA 92243

Dear Mr. Hernandez

Subject: Simplot Fertilizer Terminal Relocation Project

After review of Simplot Fertilizer Terminal Relocation Project, Campo Band of Mission Indians concludes these areas have a rich history for the Kumeyaay people. There were many villages throughout the Kumeyaay territory. Much of that history was lost when the Kumeyaay people were relocated to other areas. Campo Band of Mission Indians requests a cultural survey completed. Campo Band of Mission Indians also request to have cultural monitors from Campo be present for all future surveys and ground disturbing activities, to ensure Kumeyaay cultural resource are not overlooked. If there are any questions, please feel free to contact Marcus Cuero at marcuscuero@campo-nsn.gov or by phone (619) 478-9046.

Sincerely,

Ralph Goff

Chairman

Campo Band of Mission Indians

ADMINISTRATION / TRAINING

1078 Dogwood Road
Heber, CA 92249

Administration

Phone: (442) 265-6000
Fax: (760) 482-2427

Training

Phone: (442) 265-6011



OPERATIONS/PREVENTION

2514 La Brucherie Road
Imperial, CA 92251

Operations

Phone: (442) 265-3000
Fax: (760) 355-1482

Prevention

Phone: (442) 265-3020

August 22, 2018

RE: Conditional Use Permit #18-0020

J.R. Simplot Company 318 W. Harris Road; APN: 040-340-043

Imperial County Fire Department would like to thank you for the chance to review and comments on the J.R. Simplot Company fertilizer terminal facility located at 318 W. Harris Road, Imperial, CA 92251.

Imperial County Fire Department has the following comments and/or requirements for the fertilizer terminal facility.

- An approved water supply capable of supplying the required fire flow determined by appendix B in the California Fire Code shall be installed and maintained. Private fire service mains and appurtenance shall be installed in accordance with NFPA 24.
- An approved automatic fire suppression system shall be installed on all required structures as per the California Fire Code. All fire suppression systems will be installed and maintained to the current adapted fire code and regulations.
- An approved automatic fire detection system shall be installed on all required structures as per the California Fire Code. All fire detection systems will be installed and maintained to the current adapted fire code and regulations.
- Fire department access roads and gates will be in accordance with the current adapted fire code and the facility will maintain a Knox Box for access on site.
- Compliance with all required sections of the fire code.
- Applicant shall provide product containment areas(s) for both product and water run-off in case of fire applications and retained for removal.
- Fiscal Impacts will remain open until meeting with department head(s) and developer(s), which may include but not limited to:
 - Capital purchases which may be required to assist in servicing this project
 - Costs for services during construction and life of the project
 - Training

Imperial County Fire Department reserves the right to comment at a later time as we feel necessary.

If you have any questions, please contact the Imperial County Fire Prevention Bureau at 442-265-3020 or 442-265-3021.

Sincerely

Andrew Loper

Lieutenant/Fire Prevention Specialist

An Equal Opportunity / Affirmative Action Employer

EEC ORIGINAL PKG

**Imperial County Fire Department
Fire Prevention Bureau**

An Equal Opportunity / Affirmative Action Employer

EEC ORIGINAL PKG



IID

A century of service.

www.iid.com

Since 1911

August 21, 2018

Mr. Joe Hernandez
Planner III
Planning & Development Services Department
County of Imperial
801 Main Street
El Centro, CA 92243

SUBJECT: J.R. Simplot Company Fertilizer Terminal Relocation, CUP Application No. 18-0020

Dear Mr. Hernandez:

On August 7, 2018, the Imperial Irrigation District received from the Imperial County Planning & Development Services Department, a request for agency comments on Conditional Use Permit application no. 18-0020. The applicant, J.R. Simplot Company, proposes to relocate the fertilizer terminal facility at 302 Danenberg Drive in El Centro, CA to 318 West Harris Road in Imperial, CA.

The IID has reviewed the application and has the following comments:

1. In future submittals for this project, applicant should be advised to provide larger site plans as the one provided is very difficult to read and identify the various project components.
2. For electrical service to the new facility, the applicant should be advised to contact Ernie Benitez, IID Customer Project Development Planner at (760) 482-3405 or e-mail Mr. Benitez at eibenitez@iid.com to review the project's scope of work and initiate the electrical service application process. In addition to submitting a formal application for electrical service (see <http://www.iid.com/home/showdocument?id=12923>), the applicant will be required to submit a complete set of approved plans, project schedule, estimated in-service date, project CAD files, one-line diagram of facility, electrical loads, panel size, voltage, and the applicable fees, permits, easements and environmental compliance documentation pertaining to the provision of electrical service to the project. Any stand-by generation will require the submittal of a Regulation 21 application (available at <https://www.iid.com/home/showdocument?id=2563> to the district. A circuit study may be required; the applicant shall be responsible for any and all costs related to providing electrical service to the project, any mitigation measures required would be the financial responsibility of the developer.
3. The Imperial site currently has an overhead primary line with an existing overhead transformer bank on pole #1199212 with 3-75kVA (225Kva) 7.2/12.5kV-277/480V 3 phase 4 wire on the premises (see enclosed map).

4. Applicant should inform IID of its intentions for the existing electrical service to the J.R. Simplot site at the 302 Danenberg Drive location.
5. IID water facilities that may be impacted include the Dahlia Lateral 8 located along the site's northern boundary and the Newside Drain No. 1 located along its eastern boundary.
6. To insure there are no impacts to IID water facilities, grading, drainage and fencing plans should be submitted to IID Water Department Engineering Services prior to final project design. IID Water Engineering can be contacted at (760) 339-9265 for further information.
7. It is important to note that a change in existing drainage discharge locations may substantially alter the drainage pattern of the project site and may adversely impact IID drains. To mitigate these impacts, a comprehensive IID hydraulic drainage system analysis may be required. IID's hydraulic drainage system analysis includes an associated drain impact fee. For further information, applicant should contact IID Water Engineering Services.
8. All flows being discharge into IID's drains will have to be in conformance with the laws and regulations of Imperial County and the various state and federal agencies having jurisdiction over water quality control. Drainage restrictions are outlined in the IID's Rules and Regulations Governing the Distribution and Use of Water available at <http://www.iid.com/home/showdocument?id=7989>. The applicant should review Regulation #36 – Use of Drains, Regulation #46 – Industrial Tailwater Assessment, and Regulation No. 39 – Agricultural Tailwater Structures.
9. To obtain water for the construction phase, the applicant should be advised to contact IID South End Division at (760) 482-9800.
10. The project parcel is located outside the City of Imperial's municipal water service area and will not be receiving municipal water. Per the Safe Drinking Water Act, the applicant will need to have a contract with an approved provider to deliver their drinking water.
11. Any construction or operation on IID property or within its existing and proposed right of way or easements including but not limited to: surface improvements such as proposed new streets, driveways, parking lots, landscape; and all water, sewer, storm water, or any other above ground or underground utilities; will require an encroachment permit, or encroachment agreement (depending on the circumstances). A copy of the IID encroachment permit application and instructions for its completion are available at <http://www.iid.com/departments/real-estate>. The IID Real Estate Section should be contacted at (760) 339-9239 for additional information regarding encroachment permits or agreements. No foundations or buildings will be allowed within IID's right of way.
12. In addition to IID's recorded easements, IID claims, at a minimum, a prescriptive right of way to the toe of slope of all existing canals and drains. Where space is limited and depending upon the specifics of adjacent modifications, the IID may claim additional secondary easements/prescriptive rights of ways to ensure operation and maintenance of IID's facilities can be maintained and are not impacted and if impacted mitigated. Thus,

Joe Hernandez
August 21, 2018
Page 3

IID should be consulted prior to the installation of any facilities adjacent to IID's facilities. Certain conditions may be placed on adjacent facilities to mitigate or avoid impacts to IID's facilities.

- 13. Any new, relocated, modified or reconstructed IID facilities required for and by the project (which can include but is not limited to electrical utility substations, electrical transmission and distribution lines, etc.) need to be included as part of the project's CEQA and/or NEPA documentation, environmental impact analysis and mitigation. Failure to do so will result in postponement of any construction and/or modification of IID facilities until such time as the environmental documentation is amended and environmental impacts are fully analyzed. Any and all mitigation necessary as a result of the construction, relocation and/or upgrade of IID facilities is the responsibility of the project proponent.**

Should you have any questions, please do not hesitate to contact me at 760-482-3609 or at dvargas@ild.com. Thank you for the opportunity to comment on this matter.

Respectfully,



Donald Vargas
Compliance Administrator II

Kevin Kelley – General Manager
Mike Pacheco – Manager, Water Dept.
Enrique B. Martinez – Manager, Energy Dept.
Jamie Asbury – Deputy Manager, Energy Dept., Operations
Enrique De Leon – Asst. Mgr., Energy Dept., Distr., Planning, Eng. & Customer Service
Vance Taylor – Asst. General Counsel
Robert Laurie – Asst. General Counsel
Michael P. Kemp – Superintendent, Regulatory & Environmental Compliance
Harold Walk Jr. – Supervisor, Real Estate
Randy Gray – ROW Agent, Real Estate
Jessica Lovacchio – Environmental Project Mgr. Sr., Water Dept.

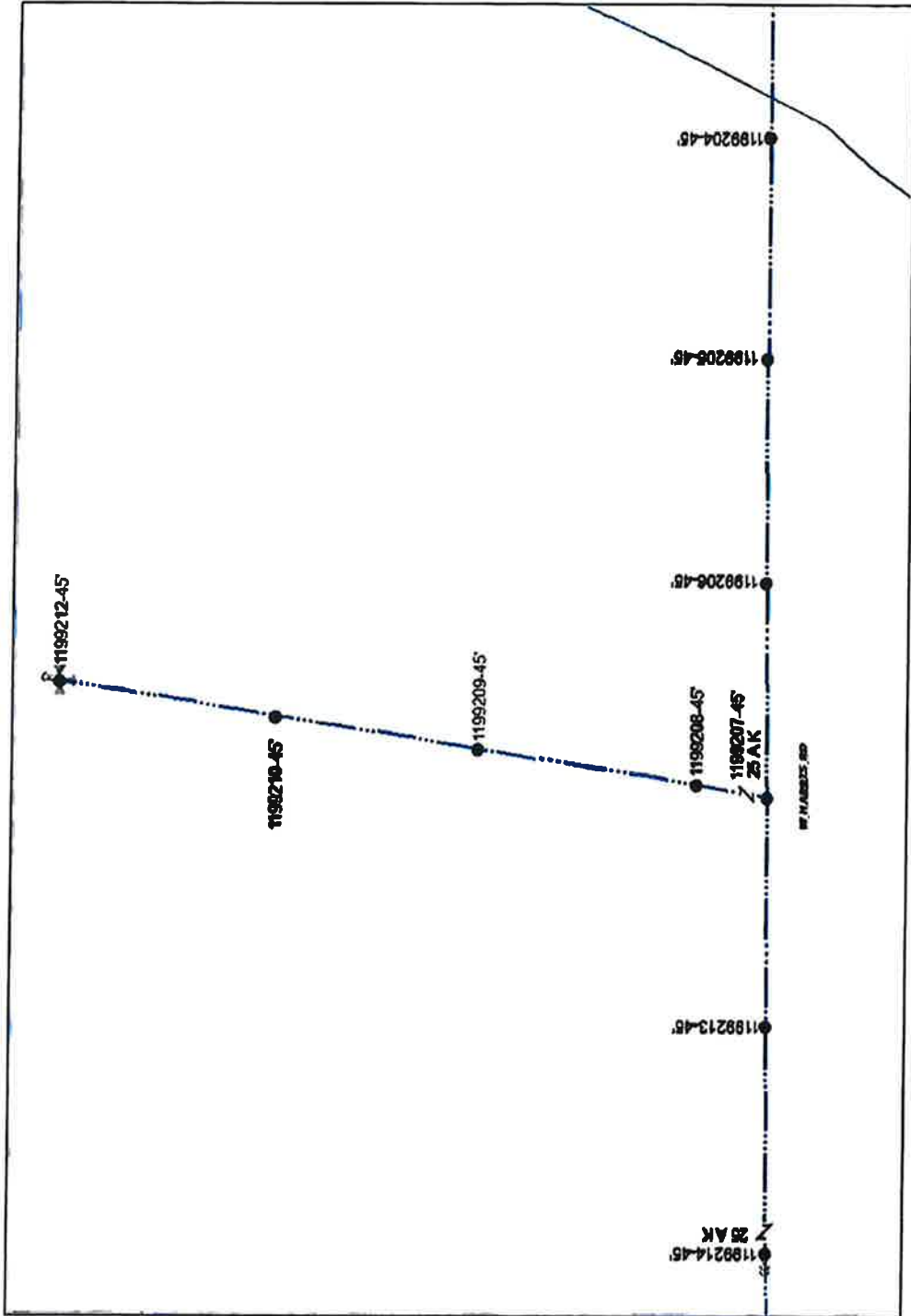

HD Electrical Facilities in the Project Area



IID

A century of service.

www.iid.com

Since 1911

October 23, 2018

**Mr. Joe Hernandez
Planner IV
Planning & Development Services Department
County of Imperial
801 Main Street
El Centro, CA 92243**

SUBJECT: J.R. Simplot Company Fertilizer Terminal Relocation, CUP Application No. 18-0020 (Recirculated)

Dear Mr. Hernandez:

On this date the Imperial Irrigation District received from the Imperial County Planning & Development Services Department, the recirculated request for agency comments on Conditional Use Permit application no. 18-0020. The applicant, J.R. Simplot Company, proposes to relocate the fertilizer terminal facility at 302 Danenberg Drive in El Centro, CA to 318 West Harris Road in Imperial, CA.

The IID has reviewed the application and finds that the comments provided in the August 21, 2018 district letter (see attached letter) continue to apply.

Should you have any questions, please do not hesitate to contact me at 760-482-3609 or at dvargas@iid.com. Thank you for the opportunity to comment on this matter.

Respectfully,

**Donald Vargas
Compliance Administrator II**

**Kevin Kelley – General Manager
Mike Pacheco – Manager, Water Dept.
Enrique B. Martínez – Manager, Energy Dept.
Jamie Asbury – Deputy Manager, Energy Dept., Operations
Enrique De Leon – Asst. Mgr., Energy Dept., Distr., Planning, Eng. & Customer Service
Vance Taylor – Asst. General Counsel
Robert Laurie – Asst. General Counsel
Michael P. Kemp – Superintendent, Regulatory & Environmental Compliance
Randy Gray – Supervisor, Real Estate
Jessica Lovecchio – Environmental Project Mgr. Sr., Water Dept.**



www.iid.com

Since 1911

August 21, 2018

Mr. Joe Hernandez
Planner III
Planning & Development Services Department
County of Imperial
801 Main Street
El Centro, CA 92243

SUBJECT: J.R. Simplot Company Fertilizer Terminal Relocation, CUP Application No. 18-0020

Dear Mr. Hernandez:

On August 7, 2018, the Imperial Irrigation District received from the Imperial County Planning & Development Services Department, a request for agency comments on Conditional Use Permit application no. 18-0020. The applicant, J.R. Simplot Company, proposes to relocate the fertilizer terminal facility at 302 Danenberg Drive in El Centro, CA to 318 West Harris Road in Imperial, CA.

The IID has reviewed the application and has the following comments:

1. In future submittals for this project, applicant should be advised to provide larger site plans as the one provided is very difficult to read and identify the various project components.
2. For electrical service to the new facility, the applicant should be advised to contact Ernie Benitez, IID Customer Project Development Planner at (760) 482-3405 or e-mail Mr. Benitez at elbenitez@iid.com to review the project's scope of work and initiate the electrical service application process. In addition to submitting a formal application for electrical service (see <http://www.iid.com/home/showdocument?id=12923>), the applicant will be required to submit a complete set of approved plans, project schedule, estimated in-service date, project CAD files, one-line diagram of facility, electrical loads, panel size, voltage, and the applicable fees, permits, easements and environmental compliance documentation pertaining to the provision of electrical service to the project. Any stand-by generation will require the submittal of a Regulation 21 application (available at <https://www.iid.com/home/showdocument?id=2563> to the district. A circuit study may be required; the applicant shall be responsible for any and all costs related to providing electrical service to the project, any mitigation measures required would be the financial responsibility of the developer.
3. The Imperial site currently has an overhead primary line with an existing overhead transformer bank on pole #1199212 with 3-75kVA (225Kva)7.2/12.5kV-277/480V 3 phase 4 wire on the premises (see enclosed map).

4. **Applicant should inform IID of its intentions for the existing electrical service to the J.R. Simplot site at the 302 Danenberg Drive location.**
5. **IID water facilities that may be impacted include the Dahlia Lateral 8 located along the site's northern boundary and the Newside Drain No. 1 located along its eastern boundary.**
6. **To insure there are no impacts to IID water facilities, grading, drainage and fencing plans should be submitted to IID Water Department Engineering Services prior to final project design. IID Water Engineering can be contacted at (760) 339-9265 for further information.**
7. **It is important to note that a change in existing drainage discharge locations may substantially alter the drainage pattern of the project site and may adversely impact IID drains. To mitigate these impacts, a comprehensive IID hydraulic drainage system analysis may be required. IID's hydraulic drainage system analysis includes an associated drain impact fee. For further information, applicant should contact IID Water Engineering Services.**
8. **All flows being discharge into IID's drains will have to be in conformance with the laws and regulations of Imperial County and the various state and federal agencies having jurisdiction over water quality control. Drainage restrictions are outlined in the IID's Rules and Regulations Governing the Distribution and Use of Water available at <http://www.iid.com/home/showdocument?id=7989>. The applicant should review Regulation #36 – Use of Drains, Regulation #46 – Industrial Tailwater Assessment, and Regulation No. 39 – Agricultural Tailwater Structures.**
9. **To obtain water for the construction phase, the applicant should be advised to contact IID South End Division at (760) 482-9800.**
10. **The project parcel is located outside the City of Imperial's municipal water service area and will not be receiving municipal water. Per the Safe Drinking Water Act, the applicant will need to have a contract with an approved provider to deliver their drinking water.**
11. **Any construction or operation on IID property or within its existing and proposed right of way or easements including but not limited to: surface improvements such as proposed new streets, driveways, parking lots, landscape; and all water, sewer, storm water, or any other above ground or underground utilities; will require an encroachment permit, or encroachment agreement (depending on the circumstances). A copy of the IID encroachment permit application and instructions for its completion are available at <http://www.iid.com/departments/real-estate>. The IID Real Estate Section should be contacted at (760) 339-9239 for additional information regarding encroachment permits or agreements. No foundations or buildings will be allowed within IID's right of way.**
12. **In addition to IID's recorded easements, IID claims, at a minimum, a prescriptive right of way to the toe of slope of all existing canals and drains. Where space is limited and depending upon the specifics of adjacent modifications, the IID may claim additional secondary easements/prescriptive rights of ways to ensure operation and maintenance of IID's facilities can be maintained and are not impacted and if impacted mitigated. Thus,**

Joe Hernandez
August 21, 2018
Page 3

IID should be consulted prior to the installation of any facilities adjacent to IID's facilities. Certain conditions may be placed on adjacent facilities to mitigate or avoid impacts to IID's facilities.

13. Any new, relocated, modified or reconstructed IID facilities required for and by the project (which can include but is not limited to electrical utility substations, electrical transmission and distribution lines, etc.) need to be included as part of the project's CEQA and/or NEPA documentation, environmental impact analysis and mitigation. Failure to do so will result in postponement of any construction and/or modification of IID facilities until such time as the environmental documentation is amended and environmental impacts are fully analyzed. Any and all mitigation necessary as a result of the construction, relocation and/or upgrade of IID facilities is the responsibility of the project proponent.

Should you have any questions, please do not hesitate to contact me at 760-482-3609 or at dvargas@iid.com. Thank you for the opportunity to comment on this matter.

Respectfully,

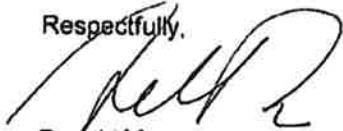

Donald Vargas
Compliance Administrator II

Kevin Kelley - General Manager
Mike Pacheco - Manager, Water Dept.
Enrique B. Martinez - Manager, Energy Dept.
Jamie Asbury - Deputy Manager, Energy Dept., Operations
Enrique De Leon - Asst. Mgr., Energy Dept., Distr., Planning, Eng. & Customer Service
Vance Taylor - Asst. General Counsel
Robert Laurie - Asst. General Counsel
Michael P. Kemp - Superintendent, Regulatory & Environmental Compliance
Harold Walk Jr. - Supervisor, Real Estate
Randy Gray - ROW Agent, Real Estate
Jessica Lovacchio - Environmental Project Mgr. Sr., Water Dept.

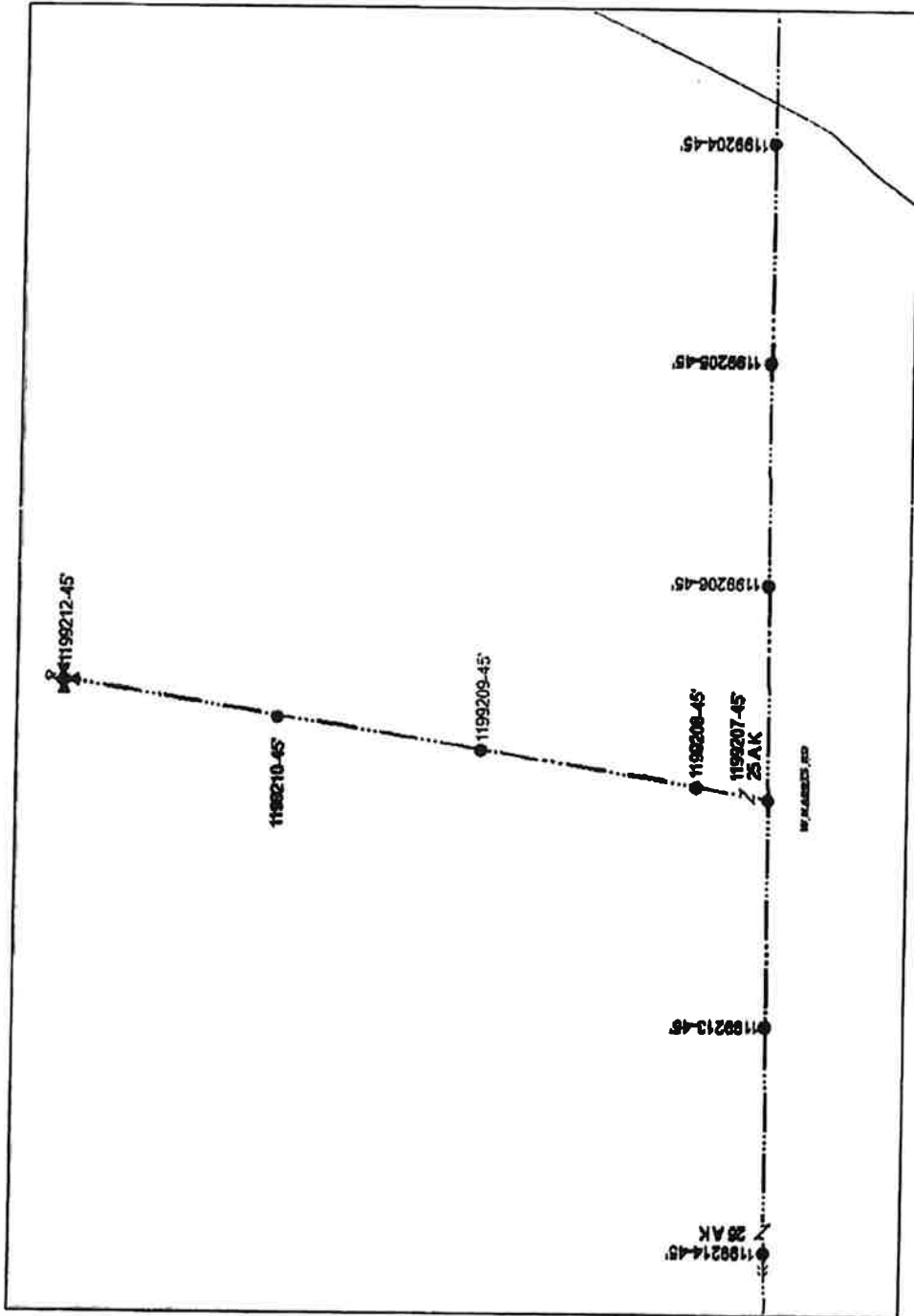

IID Electrical Facilities in the Project Area



Public Works works for the Public



COUNTY OF
IMPERIAL

DEPARTMENT OF
PUBLIC WORKS

155 S. 11th Street
El Centro, CA
92243

Tel: (442) 265-1818
Fax: (442) 265-1858

Follow Us:



www.facebook.com/ImperialCountyDPW



<https://twitter.com/CountyDpw>

January 18, 2019

RECEIVED

JAN 22 2019

IMPERIAL COUNTY
PLANNING & DEVELOPMENT SERVICES

Mr. Jim Minnick, Director
Planning & Development Services Department
801 Main Street
El Centro, CA 92243

Attention: Joe Hernandez, Planner IV

SUBJECT: CUP 18-0020 J.R. Simplot Company
Located on 318 West Harris Road, Imperial, CA 92251
APN 040-340-043

Dear Mr. Minnick:

This letter is in response to your submittal received by this department on August 7, 2018 for the above mentioned project. The project proposes to relocate a fertilizer terminal facility to the location listed above.

Department staff has reviewed the package information and the following comments shall be Conditions of Approval:

1. No road right of way conditions required. Sufficient right of way has been deeded to meet road classification per Doc# 2009-020043. (As directed by Imperial County Board of Supervisors per Minute Order #6 dated 11/22/1994 per the Imperial County Circulation Element Plan of the General Plan).
2. Each parcel created or affected by this project shall abut a maintained road and/or have legal and physical access to a public road before the project documents are recorded.
3. The applicant shall furnish a Drainage and Grading Plan/Study to provide for property grading and drainage control, which shall also include prevention of sedimentation of damage to off-site properties. The Plan/Study shall be prepared per the Engineering Design Guidelines Manual for the Preparation and checking of Street Improvement, Drainage, and Grading Plans within Imperial County and submitted to the Department of Public Works for review and approval. The applicant shall implement the approved plan. Employment of the appropriate Best Management Practices (BMPs) shall be included on the plan.
4. The applicant for grading plans and/or improvement plans is responsible for researching, protecting, and preserving survey monuments per the Professional Land Surveyor's Act (8771 (b)). This shall include a copy of the referenced survey map

and tie card(s) (if applicable) for all monuments that may be impacted by the project whether it be on-site or off-site.

5. Per Section 12.10.020 - Street Improvement Requirements of Imperial County Ordinance:

- a. Street improvements shall be required in conjunction with, but not limited to, any construction, grading, or related work, including the construction of structures, buildings, or major additions thereto, on property located adjacent to any county street or on property utilizing any county street for ingress and egress, except that such improvements may be deferred as described in Section 12.10.040 of this chapter for residential property.
- b. For the purpose of establishing proper standards, specification and directions for design and construction of any road, or other land division improvements required to be constructed in the unincorporated territory of Imperial County, the document entitled "Engineering Design Guidelines Manual for the Preparation and checking of Street Improvement, Drainage, and Grading Plans within Imperial County" revision dated September 15, 2008, is hereby adopted and made a part of this division by reference, three copies of which are on file in the office of the clerk of the board of supervisors and for use and examination by the public. Copies of the manual can also be found at the Imperial County Department of Public Works.

6. Per Section 12.10.030 - Building Permits of Imperial County Ordinance:

- a. No building permit for any structure or building or major addition to a building or structure shall be issued until the improvements required by Section 12.10.010 of this chapter have been installed or a deferral agreement has been executed and recorded as provided in Section 12.10.040 of this chapter. In addition, no building permit shall be issued until there has been compliance with Chapter 12.12 of this title and the requirement that an encroachment permit be obtained.

7. Any activity and/or work within Imperial County right-of-way shall be completed under a permit issued by this Department (encroachment permit) as per Chapter 12.12 – Excavations on or Near a Public Road of the Imperial County Ordinance. Any activity and/or work may include, but not be limited to, construction of primary access driveways, secondary fire access driveways, installation of temporary traffic control devices during construction, etc.

8. Table 8-1 – Near-Term Intersection Operations of the Transportation Impact Analysis lists the intersection of State Route 86 and Harris Road and the

intersection of State Route 86 and Barioni Boulevard with a Level of Service of "D". However, Section 11.0 – Conclusions & Recommendations states that the project would not create significant impacts and that no mitigation measures are necessary.

- a. Objective 1.12 of the Imperial County Circulation and Scenic Highways Element states the following:

Review new development proposals to ensure that the proposed development provides adequate parking and would not increase traffic on existing roadways and intersection to a level of service (LOS) worse than "C" without providing appropriate mitigations to existing infrastructure. This can include fair share contributions on the part of developers to mitigate traffic impacts caused by such proposed developments.

The Developer shall propose mitigation measures for the intersection of State Route 86 and Harris Road (Imperial County) and the intersection of State Route 86 and Barioni Boulevard (City of Imperial). The proposed mitigation measures shall be submitted to this Department for review and approval prior to the approval of this Conditional Use Permit.

Respectfully,

John A. Gay, PE
Director of Public Works

By:



Francisco Olmedo, PE
Senior Engineer

ag

Joe Hernandez

From: Monica Soucier
Sent: Friday, May 10, 2019 11:05 AM
To: Matthew Harmon
Cc: Annette Leon; Joe Hernandez
Subject: RE: J.R. Simplot- Air Quality

Matt

Just to memorialize our verbal conversation. Joe received a response from the Air District indicating that as presented there were not additional issues from the Air District and there were no comments regarding J.R. Simplot's response letter to our comments.

Balancing Science and Technology to achieve cleaner air for a cleaner future

Monica N. Soucier

APC Division Manager
Planning and Monitoring
P. (442) 265-1800
FAX - (442) 265-1799

From: Matthew Harmon <matthew@dubosedesigngroup.com>
Sent: Thursday, May 09, 2019 8:35 AM
To: Monica Soucier <MonicaSoucier@co.imperial.ca.us>
Cc: Annette Leon <annette@dubosedesigngroup.com>; Joe Hernandez <JoeHernandez@co.imperial.ca.us>
Subject: J.R. Simplot- Air Quality

CAUTION: This email originated outside our organization; please use caution.

Morning Monica!

I am circling back around to you regarding the air quality comment letter & response to the comment letter. Were you satisfied with our questions to your comments? I have attached both documents for your reference.

Matt

MATTHEW HARMON, Assistant Planner



1065 State Street, El Centro, CA 92243
Office #: 760-353-8110

IX Mitigation Monitoring & Reporting Program (MM&RP)

MITIGATION, MONITORING AND REPORTING PROGRAM

DRAFT MITIGATION MEASURES PURSUANT TO THE ENVIRONMENTAL EVALUATION COMMITTEE

J.R. Simplot Company
[CUP #18-0020]

(APN 040-430-043-000)

(CEQA – Mitigated Negative Declaration)

Pursuant to the review and recommendations of the Imperial County Environmental Evaluation Committee (EEC) on _____, 2019, the following Mitigation Measures are hereby proposed for the project:

Biological Resources:

MITIGATION MEASURE #1: (for a)

- Burrowing Owl (BUOW) shelter in place (using hay bales) and remove shelters when project is complete under supervision of qualified biologist. If passive relocation are required, a qualified biologist shall consult with California Department of Fish and Wildlife (CDFW), Palm Desert Office.
- Worker BUOW training sessions.
- Monitoring when construction is within 250 feet (February – August); 160 feet (September – January) if determined necessary by qualified biologist.
- If Construction starts during Migratory Bird Nesting season (February – August) a nesting bird survey should be completed one week prior to start of construction.
- Within 14 days and 24 hours of start of construction, BUOW survey.

(Monitoring Agency: California Department of Fish and Wildlife (CDFW)/Planning & Development Services Department)

Geology and Soils:

MITIGATION MEASURE #2: (1 & 2)

- Type C backfill must be used in wet soils and below groundwater for all buried utility pipelines. Where pipeline excavation are planned below the ground water surface, dewatering (by well points) is required to at least 24 inches below the trench bottom prior to excavation. Type A backfill may be used in the case of a dewatered trench condition in clay soils only.

(Monitoring Agency: Planning & Development Services Department)

Utilities and service systems:

MITIGATION MEASURE #3 (C)

- Prior to issuance of any building permit for any new building within the project, development impact mitigation fees as provided by the County Municipal Code. In addition, the building permit application shall be evidence to the satisfaction of the Planning and Development Services Director and Fire Chief that an adequate system of water storage and pumping for fire protection exists for the project or will be constructed and available for use upon completion of the building. This shall include an agreement between the applicant and property owner with the County Fire Department that a specific minimum volume of water in the storage pond will be maintained at all times. All facilities required for fire protection services shall be installed and in working order prior to issuance of a certificate of occupancy for the building.

(Monitoring Agency: Fire Department/Planning & Development Services Department)

Conditional Use Permit Application
(Attachment to application are separated by yellow sheets)

CONDITIONAL USE PERMIT

I.C. PLANNING & DEVELOPMENT SERVICES DEPT.
801 Main Street, El Centro, CA 92243 (760) 482-4236

- APPLICANT MUST COMPLETE ALL NUMBERED (black) SPACES - Please type or print -

1. PROPERTY OWNER'S NAME J.R. Simplot Company		EMAIL ADDRESS Gary.L.Smith@simplot.com / aleon@dde-inc.net	
2. MAILING ADDRESS (Street / P O Box, City, State) 302 Danenberg Drive, El Centro, CA		ZIP CODE 92243	PHONE NUMBER 1-760-352-8931
3. APPLICANT'S NAME J.R. Simplot Company		EMAIL ADDRESS Gary.L.Smith@simplot.com / aleon@dde-inc.net	
4. MAILING ADDRESS (Street / P O Box, City, State) 302 Danenberg Drive, El Centro, CA		ZIP CODE 92243	PHONE NUMBER 1-760-352-8931
4. ENGINEER'S NAME Carlos Corrales	CA. LICENSE NO. 55432	EMAIL ADDRESS carloscorrales@dde-inc.net	
5. MAILING ADDRESS (Street / P O Box, City, State) 1065 W. State Street, El Centro, CA		ZIP CODE 92243	PHONE NUMBER 1-760-353-8110
6. ASSESSOR'S PARCEL NO. 040-340-041	SIZE OF PROPERTY (in acres or square foot) 39.96 +/- acres	ZONING (existing) ML 1-2 (Light Industrial)	
7. PROPERTY (site) ADDRESS Please reference Assessor's Parcel Numbers 318 WEST HARRIS ROAD			
8. GENERAL LOCATION (i.e. city, town, cross street) North side of Harris Road, 1/2 mile east of S.R. 86, and West of Union Pacific Rail Road. Inside the Mesquite Lake Specific Plan Area in Imperial County.			
9. LEGAL DESCRIPTION <u>Please see Attachment A. and Preliminary Title Report</u>			

PLEASE PROVIDE CLEAR & CONCISE INFORMATION (ATTACH SEPARATE SHEET IF NEEDED)

10. DESCRIBE PROPOSED USE OF PROPERTY (list and describe in detail)	
<u>This is a relocation of the fertilizer terminal located at 302 Danenberg Drive, El Centro. The Terminal will receive, warehouse and ship fertilizer. The facility will have capacity to store 14,075 tons of up to eight product segregations of dry fertilizer, and 15,000 tons of up to four product segregations of liquid fertilizer.</u>	
11. DESCRIBE CURRENT USE OF PROPERTY	<u>Agriculture</u>
12. DESCRIBE PROPOSED SEWER SYSTEM	<u>On-site septic system</u>
13. DESCRIBE PROPOSED WATER SYSTEM	<u>Water will be delivered in tanks by truck from a water supplier</u>
14. DESCRIBE PROPOSED FIRE PROTECTION SYSTEM	<u>This site will comply with appropriate county fire protection regulations</u>
15. IS PROPOSED USE A BUSINESS? <input checked="" type="checkbox"/> Yes <input type="checkbox"/> No	IF YES, HOW MANY EMPLOYEES WILL BE AT THIS SITE? <u>6 employees</u>

I / WE THE LEGAL OWNER (S) OF THE ABOVE PROPERTY CERTIFY THAT THE INFORMATION SHOWN OR STATED HEREIN IS TRUE AND CORRECT.

GARY SMITH 7-16-18
Print Name Date
Gary Smith
Signature
Print Name Date
Signature

REQUIRED SUPPORT DOCUMENTS

A. SITE PLAN	_____
B. FEE	_____
C. OTHER	_____
D. OTHER	_____

APPLICATION RECEIVED BY:	<u>Double Jetter</u>	DATE	<u>07.17.18</u>	REVIEW / APPROVAL BY OTHER DEPT'S required
APPLICATION DEEMED COMPLETE BY:	_____	DATE	_____	<input type="checkbox"/> P. W.
APPLICATION REJECTED BY:	_____	DATE	_____	<input type="checkbox"/> E. H. S.
TENTATIVE HEARING BY:	_____	DATE	_____	<input type="checkbox"/> A. P. C. D.
FINAL ACTION:	<input type="checkbox"/> APPROVED <input type="checkbox"/> DENIED	DATE	_____	<input type="checkbox"/> G. E. S.

CUP #
18-0020

ATTACHMENT A

THE LAND REFERRED TO IN THIS REPORT IS SITUATED IN THE STATE OF CALIFORNIA, COUNTY OF IMPERIAL AND IS DESCRIBED AS FOLLOWS:

THOSE PORTIONS OF TRACTS 141 AND 183, TOWNSHIP 14 SOUTH, RANGE 14 EAST, S.B.M., IN AN UNINCORPORATED AREA OF THE COUNTY OF IMPERIAL, STATE OF CALIFORNIA, ACCORDING TO THE OFFICIAL PLAT THEREOF, SHOWN AND DESIGNATED AS PARCELS 3 AND 4 OF PARCEL MAP NO. M-2316 ON FILE IN BOOK 11, PAGE 65 OF PARCEL MAPS IN THE OFFICE OF THE COUNTY RECORDER OF IMPERIAL COUNTY.

J.R. Simplot-Fertilizer Terminal

Relocation

RECEIVED

JUL 17 2018

IMPERIAL COUNTY
PLANNING & DEVELOPMENT SERVICES

Client: J.R. Simplot Company

Engineer: LC Engineering Consultants, Inc.

Planner: DuBose Design Group, Inc.

Location: North side of Harris Road, ¼ mile east of State Route (S.R.) 86, and West of Southern Pacific Rail Road. Within the Mesquite Lake Specific Plan Area in Imperial County.

Project Size: 39.96 +/- Acres

APN: 040-340-043

Date: 6/26/2018

Proposed Activities:

J.R. Simplot Company ("applicant") proposes to relocate its' fertilizer warehouse/terminal where fertilizer will be received, warehoused and shipped. The project site will receive both solid and liquid fertilizers via Southern Pacific Rail Road, and distribute the fertilizer via trucks. In terms of fertilizer, the facility will utilize segregation for storage purposes. Segregation is a mixture of different kinds of fertilizers in order to obtain a predicted N -P -K¹ chemical composition of solid fertilizer (Miserque, O., and E. Pirard). Therefore, the facility will have the capacity to store 14,075 tons of eight different dry/solid product segregations, and 15,000 tons of four different product segregations of liquid fertilizer. Both the liquid and solid fertilizer will be shipped via truck to recipients.

¹ N- Nitrogen, P-Phosphorus, K-Potassium

Proposed Project Site and Circulation:

The entire APN 040-340-043 is currently situated on approximately 39.96 +/- acres of land located within the County of Imperial, about 2 miles north of the City of Imperial². Currently, the project site is zoned ML-I-2 (Medium-Industrial) and is within the Mesquite Lake Specific Plan³, as seen in Figure 1.

The primary entrance for the facility is on Harris Road, west of the Southern Pacific Railroad tracks. This primary entrance will receive automobiles for employees and business related traffic. Traffic related activity will include inspections, employees, visitors as well as distribution trucks. Per the County Fire Marshall, a secondary access point will be required for emergency access only. This entrance shall not affect the amount of project traffic counts and will be located just west of the main entrance. Trucks will travel on S.R. 86 for distribution to the end users' locations according to the proposed site plan. There will be paved roadway on site for queuing of trucks.

Operations:

Solid Fertilizer:

Located at the northern portion of the facility, a proposed rail yard will be used for unloading fertilizer material⁴, as seen in Figure 2. At the north/western side of the facility a 250 TPH drag chain bucket elevator and conveyor will transfer dry fertilizer products from the train cars into Dry Bulk Warehouse 1. The conveyor will receive the product at a shallow rail receiving pit, placed below the working track, and convey the material to a diverter located within the Dry

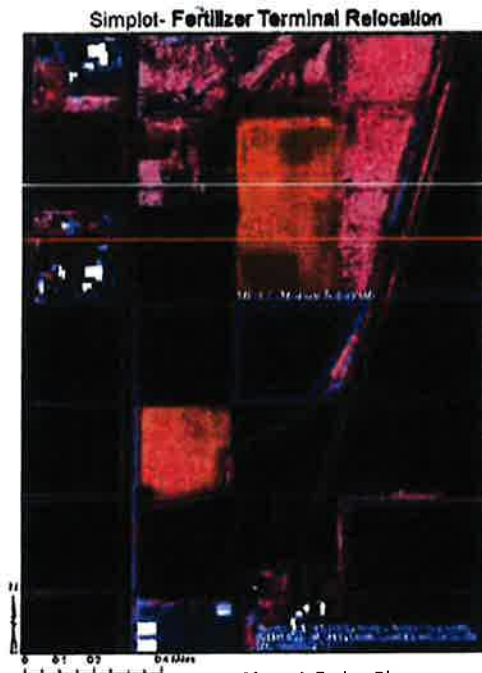

Figure 1. Project Site

² Please Reference Appendix A

³ Please Reference Appendix B

⁴ Please Reference Appendix C

Bulk Warehouse 1. Once fertilizer reaches this diverter, there are two options; (a) the fertilizer will be diverted via a conveyor belt to be stored within Dry Bulk Warehouse 1 and (b) the fertilizer will be transported via an additional covered conveyor belt that will run perpendicular from Dry Bulk Warehouse 1 to its destination in Dry Bulk Warehouse 2 where the fertilizer will be stored.

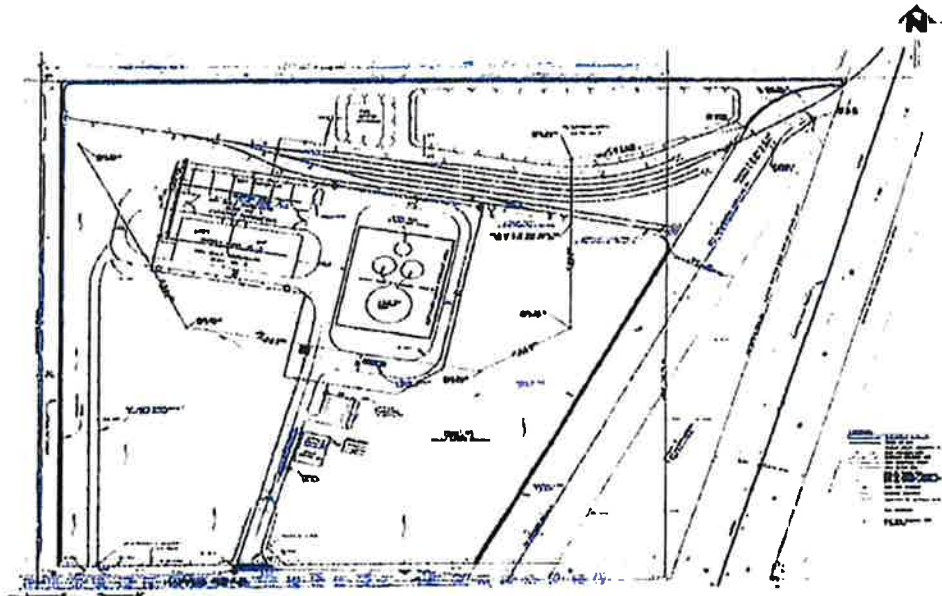

Figure 2. Site Plan

Walls separating the different types of fertilizer will be 10' high, made out of large cement blocks, and will be moveable to allow for seasonal and market demand fluctuations (see Figure 3). The two warehouse buildings are identical in size: 100' x 340' with a peak height of 50'. The buildings will be set up to allow drive through loading. A passageway will be constructed between the buildings to allow a front end loader to travel between the buildings. Prior to operation of drag chain bucket elevator, applicant will have filed and received permitted approval.



Figure 3. Cement Blocks

Liquid Fertilizer:

Located on the north/eastern side of the facility will be two stations for the unloading of liquid fertilizers from train cars⁵. All unloading stations will have spill containment area constructed of curbs and concrete slabs. Five 60 Horse Power (HP) pumps will be located at these unloading stations in order to pump the liquid fertilizer to the Contained Liquid Storage Area, where the liquid fertilizer will be stored in four different storage tanks ranging in sizes⁶. Once liquid fertilizer is ready to be transported to recipients, a 25 HP pump will pump liquid fertilizer to the loading location. This location will have four different outlets connected to the four different storage tanks.

The fertilizer will be weighed by a 10'x80' fully electronic scale located north of the primary access. The product will be weighted via electronic scale upon receipt and before shipping to clients.

Proposed Project Boundary:

This project will be responsible for granting one half of eighty four (84'-00") of Right-of-Way (ROW), along both the western and southern project boundaries. A thirty five (35'-00") ROW already exists along the project's southern boundary (Harris Road); this project will dedicate the additional seven (7'-00") to meet that required forty two (42'-00") of ROW. Additionally, the project will have to dedicate the entire forty two (42'-00") of ROW on the western boundary.

⁵ Please Reference Appendix C

⁶ Please Reference Appendix C

Utilities:

The applicant will have an agreement with the County of Imperial to supply potable water via reservoir tanks. Due to project site location, sewage will be disposed via septic tank and leach bed field. An office and maintenance shop will be provided for employees, along with corresponding amount of parking. Outside lighting will be provided for night operations. Applicant wishes to adhere to all Imperial County land use and zoning regulations required for this location.

Jurisdictions:

- 1) County of Imperial

Applications:

- 1) Conditional Use Permit (CUP) - County of Imperial
- 2) Site Plan

Planned Studies:

- 1) Traffic Study- Linscott, Law & Greenspan
- 2) Phase 1 ESA- GS Lyon
- 3) Geotechnical- LandMark
- 4) Biological/Burrowing Owl-Ultrasonics



WORK CITED

Miserque, O., and E. Pirard. "Segregation of the Bulk Blend Fertilizers." *Science Direct, Elsevier / Chemometrics and Intelligent Laboratory Systems*, 24 June 2004, [orbi.uliege.be/bitstream/2268/41057/1/PUB_2003_04_EP_Fertilizer Blend Segregation.pdf](http://orbi.uliege.be/bitstream/2268/41057/1/PUB_2003_04_EP_Fertilizer_Blend_Segregation.pdf).

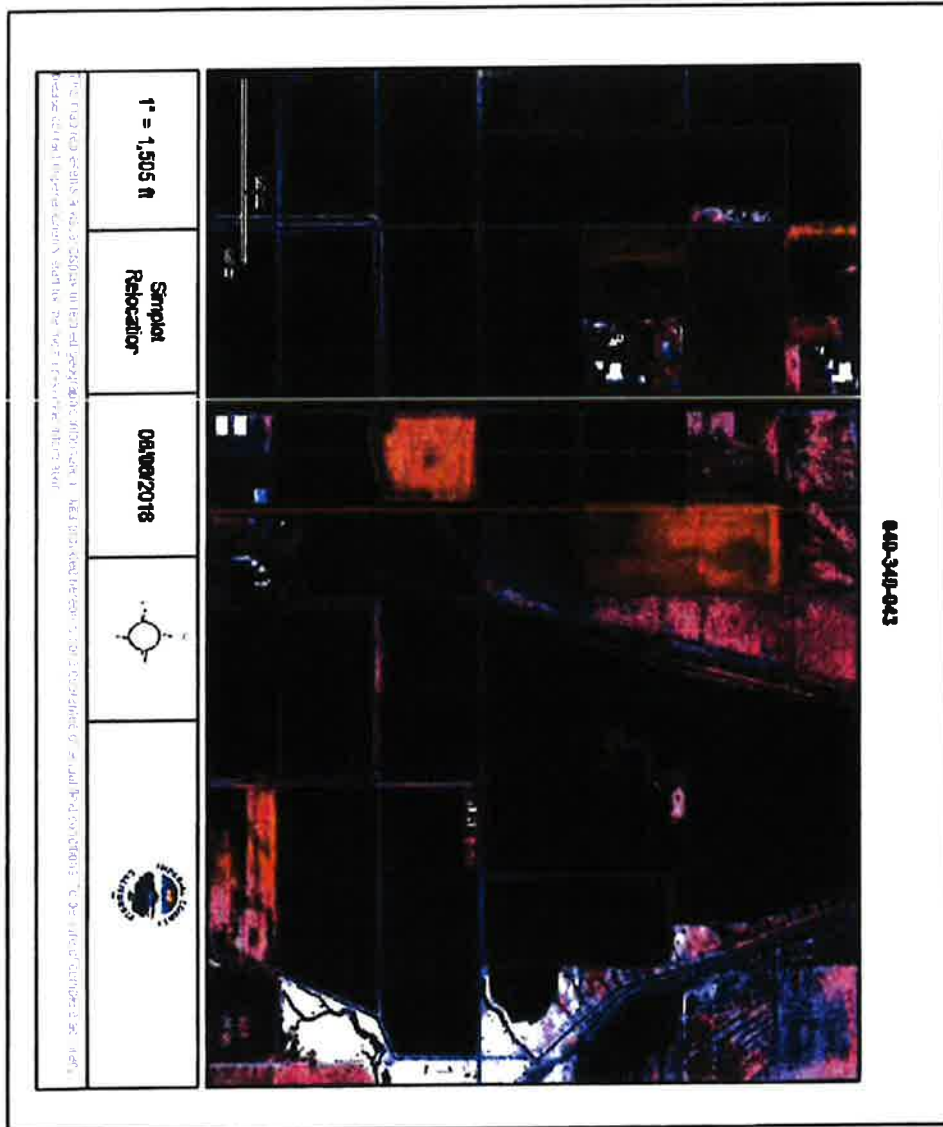
Appendix A



640-340-043

1" = 1,505 ft	Simplex Relocation	08/08/2018		
---------------	--------------------	------------	---	---

The provided aerial photograph is for informational purposes only. It is not intended to be used as a substitute for a professional site visit or other engineering or architectural services. The City of Dallas is not responsible for any errors or omissions in this document.

Appendix B

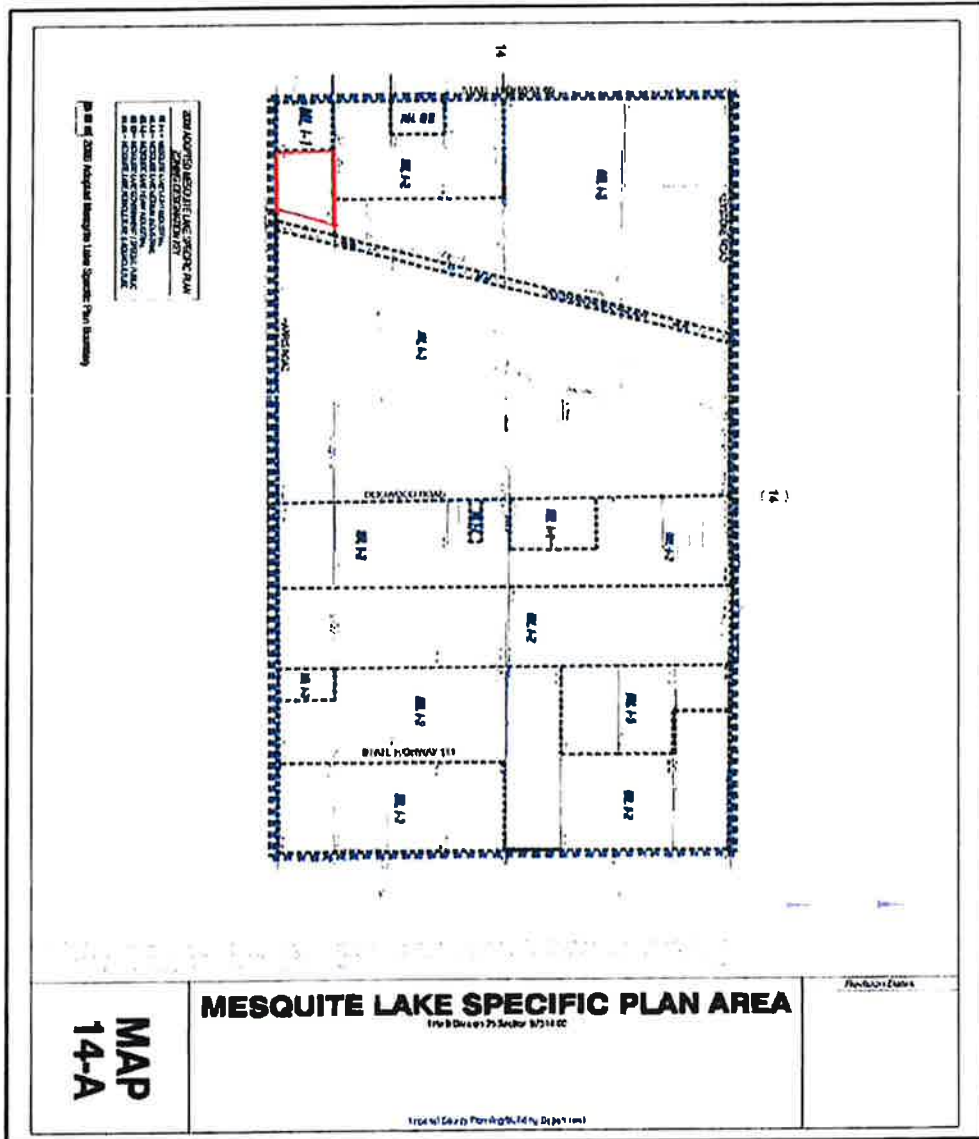

Appendix C

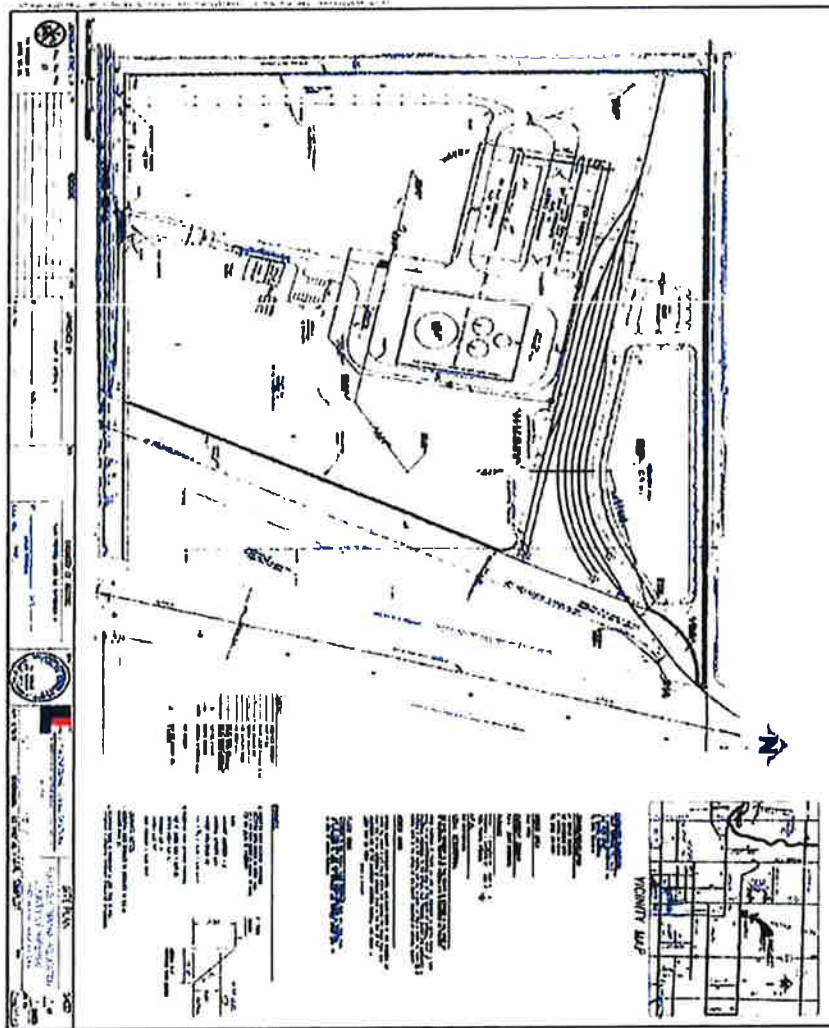

Transportation Impact Analysis (dated April 16, 2019)

EEC ORIGINAL PKG

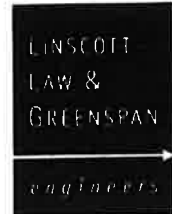

TRANSPORTATION IMPACT ANALYSIS
SIMPLOT-FERTILIZER TERMINAL
RELOCATION PROJECT
County of Imperial, California
April 16, 2019

LLG Ref. 3-18-2968

Prepared by:
Jose Nunez
Transportation Planner II

Under the Supervision of:
John A. Boarman
Principal

**Linscott, Law &
Greenspan, Engineers**
4542 Ruffner Street
Suite 100
San Diego, CA 92111
858.300.8880 T
858.300.8870 F
www.llgengineers.com

EEC ORIGINAL PKG

TABLE OF CONTENTS

SECTION	PAGE
Appendices	ii
List of Figures	iii
List of Tables	iv
1.0 Introduction	5
2.0 Project Description	6
2.1 Project Location	6
2.2 Project Description.....	6
2.3 Project Access.....	6
3.0 Existing Conditions	10
3.1 Existing Street Network.....	10
3.2 Existing Traffic Volumes.....	10
4.0 Analysis Approach and Methodology	14
4.1 Intersections	15
4.2 Street Segments.....	15
5.0 Significance Criteria	17
6.0 Analysis of Existing Conditions	18
6.1 Peak Hour Intersection Levels of Service.....	18
6.2 Daily Street Segment Levels of Service	19
7.0 Trip Generation/Distribution/Assignment	20
7.1 Trip Generation.....	20
7.2 Trip Distribution/Assignment	21
8.0 Cumulative	28
8.1 Existing + Total Project Analysis	28
8.1.1 Intersection Operations	28
8.1.2 Segment Analysis.....	28
8.2 Existing + Total Project + Cumulative Analysis	28
8.2.1 Intersection Analysis.....	28
8.2.2 Segment Analysis.....	28
9.0 Project Access	32

10.0 Conclusions & Recommendations 33

APPENDICES

APPENDIX

- A. Intersection Count Sheets & Caltrans Traffic Volumes**
- B. Peak Hour Intersection Analysis Worksheets**

LIST OF FIGURES

SECTION—FIGURE #	PAGE
Figure 2-1 Vicinity Map	7
Figure 2-2 Project Area Map	8
Figure 2-3 Site Plan	9
Figure 3-1 Existing Conditions Diagram.....	12
Figure 3-2 Existing Traffic Volumes.....	13
Figure 7-1 Project Distribution – Truck Trips.....	22
Figure 7-2 Project Distribution – Employee/Miscellaneous Trips.....	23
Figure 7-3 Project Traffic Volumes – Truck Trips.....	24
Figure 7-4 Project Traffic Volumes – Employee/Miscellaneous Trips.....	25
Figure 7-5 Project Traffic Volumes – Total Trips.....	26
Figure 7-6 Existing + Total Project Traffic Volumes.....	27
Figure 8-1 Existing + Total Project + Cumulative Traffic Volumes.....	31

LIST OF TABLES

SECTION—TABLE #	PAGE
Table 3-1 Existing Traffic Volumes.....	11
Table 4-1 Intersection LOS & Delay Ranges.....	15
Table 4-2 Imperial County Standard Street Classification Average Daily Vehicle Trips	16
Table 5-1 Traffic Impact Significant Thresholds.....	17
Table 6-1 Existing Intersection Operations.....	18
Table 6-2 Existing Street Segment Operations	19
Table 7-1 Trip Generation.....	20
Table 8-1 Near-Term Intersection Operations	29
Table 8-2 Near-Term Street Segment Operations.....	30

TRANSPORTATION IMPACT ANALYSIS
SIMPLOT-FERTILIZER TERMINAL
RELOCATION PROJECT
County of Imperial, California
April 16, 2019

1.0 INTRODUCTION

The following traffic impact analysis has been prepared to determine the potential transportation impacts to the local circulation system due to the Simplot-Fertilizer Terminal Relocation project. The site is located north of Harris Road, immediately west of the railroad tracks and a quarter mile east of SR 86 within the Mesquite Lake Specific Plan Area in the County of Imperial.

This report includes the following sections:

- Project Description
- Existing Conditions
- Analysis Approach and Methodology
- Significance Criteria
- Analysis of Existing Conditions
- Trip Generation / Distribution / Assignment
- Near-Term / Roadway Capacity Analysis
- Project Access discussion
- Conclusions and Recommendations

2.0 PROJECT DESCRIPTION

2.1 Project Location

The 40-acre Jr. Simplot-Fertilizer site is located north of Harris Road, immediately west of the railroad tracks and a quarter mile east of SR 86 in the County of Imperial. The project site is zoned ML-I-2 (Medium-Industrial) and is within the Mesquite Lake Specific Plan.

Figure 2-1 depicts the project vicinity. *Figure 2-2* shows a more detailed project area map. *Figure 2-3* shows the site plan.

2.2 Project Description

The applicant proposes to relocate its fertilizer warehouse/terminal where fertilizer will be received, warehoused, and shipped. The project site will receive both solid and liquid fertilizers via rail (Southern Pacific railroad) and distribute the fertilizer via trucks. The facility will have the capacity to store eight different dry/solid product segregations, and 15,000 tons of four different product segregations of liquid fertilizer. Both the liquid and solid fertilizer will be shipped via truck to recipients.

This transportation study will analyze the potential impacts of these additional trucks to the surrounding street system.

2.3 Project Access

Access to the project site will be via one (1) driveway to Harris Road. A secondary "Emergency Access only" gated driveway will also be provided to the west of the main access driveway.



N:12988-Figures
Date: 09/10/18

Figure 2-1

Vicinity Map

SIMPLOT FERTILIZER TERMINAL RELOCATION PROJECT

EEC ORIGINAL PKG

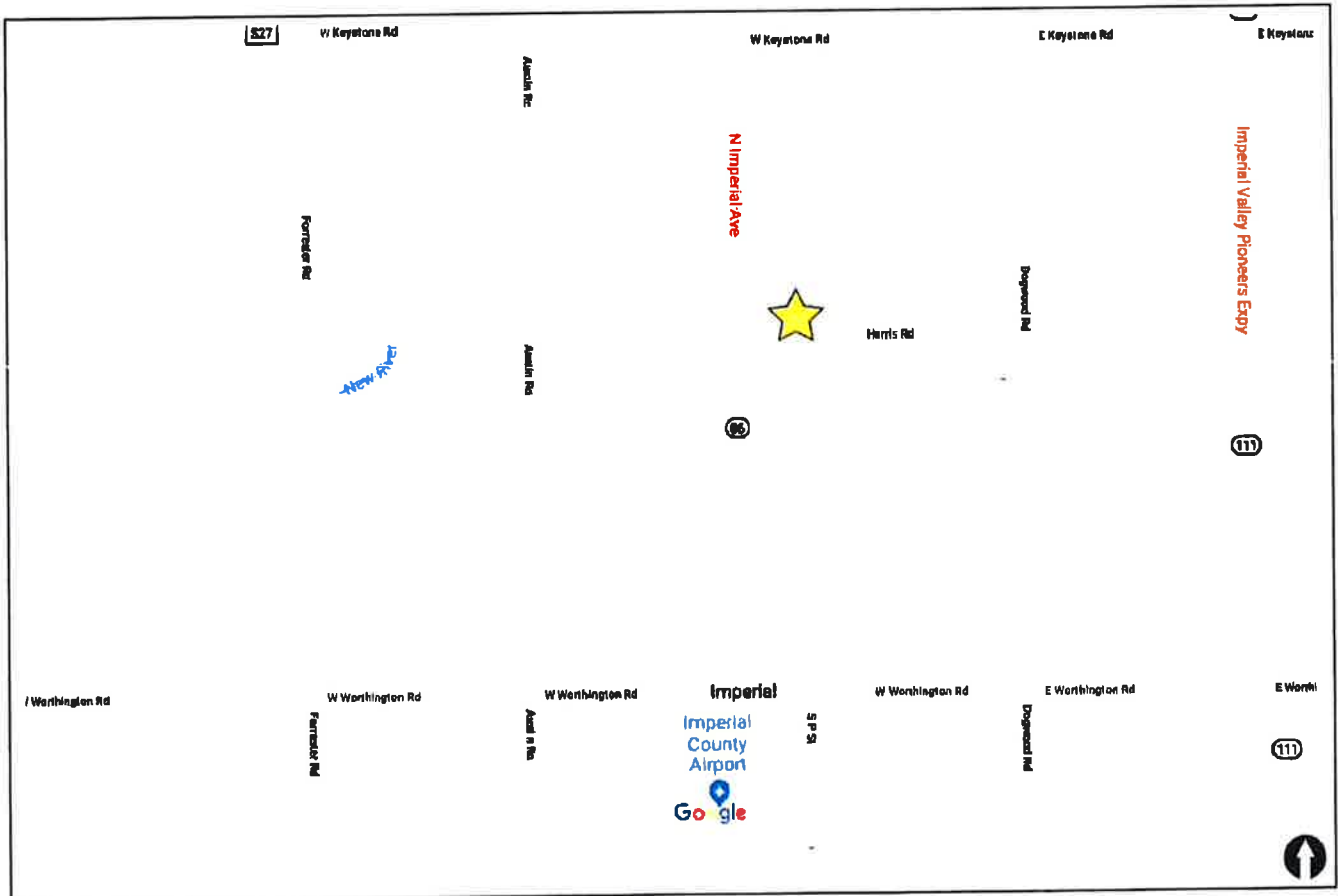
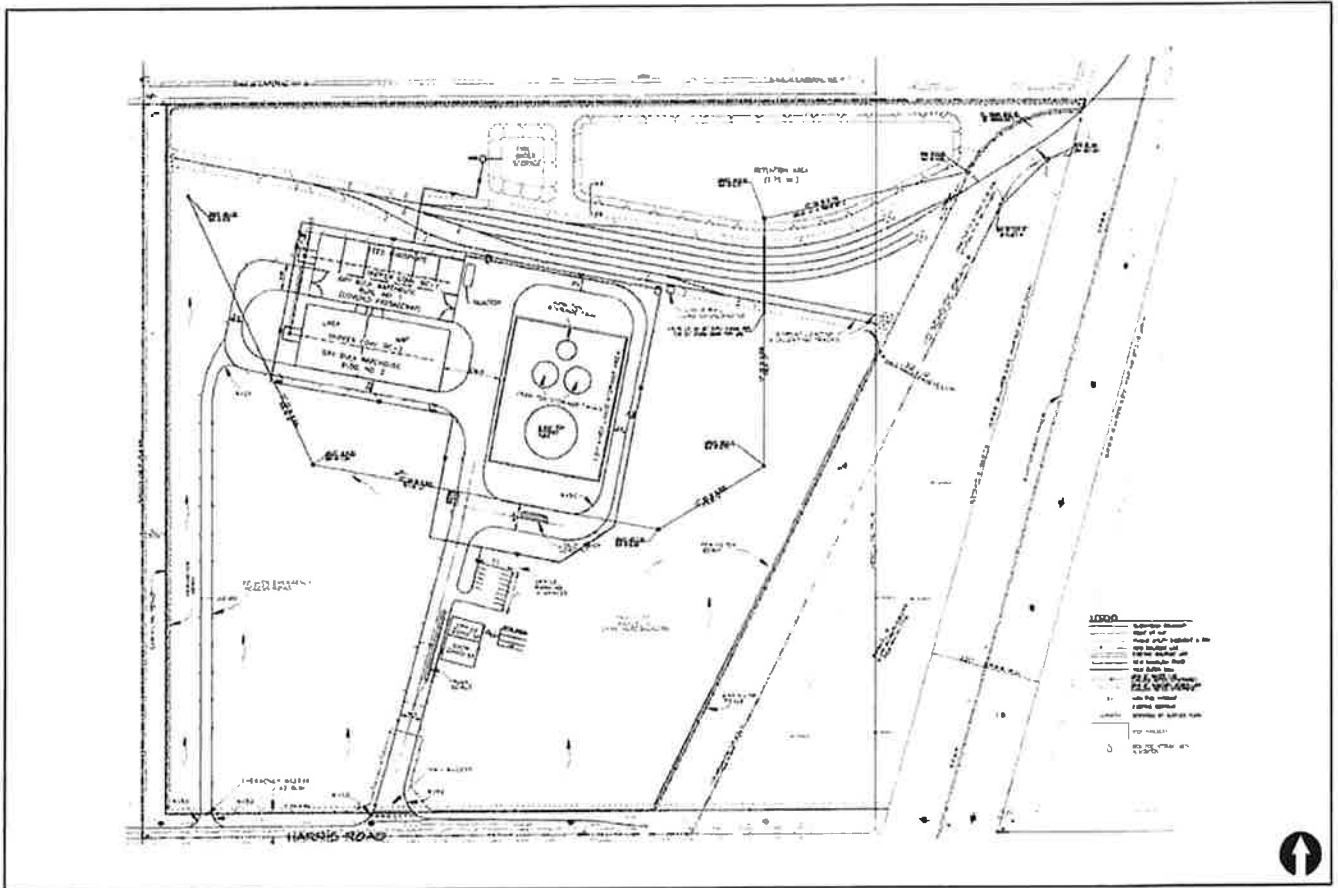

Figure 2-2

Project Area Map

SIMPLOT FERTILIZER TERMINAL RELOCATION PROJECT

 JOHN DEERE
 LAW &
 GREENWAY
 ENGINEERS
 1435007/fig.002
 Date: 08/16/18



UNIST
 IAR &
 GREENBERG
 ENGINEERS

N:22680 figures
 Date: 09/10/18

Figure 2-3
 Site Plan

SIMPLLOT FERTILIZER TERMINAL RELOCATION PROJECT

3.0 EXISTING CONDITIONS

3.1 Existing Street Network

Following is a brief description of the street segments within the project area. *Figure 3-1* illustrates the existing conditions, including the lane geometry, for the key intersections in the study area.

State Route 111 (SR-111) is classified as a State Highway on the Imperial County Circulation Element. SR 111 is a north-south facility located east of the project site. In the vicinity of the project, SR-111 is constructed as a four-lane divided (2-lanes per direction) highway.

State Route 86 (SR-86) is classified as a State Highway on the Imperial County Circulation Element. SR 86 is a north-south facility located west of the project site. In the vicinity of the project, SR-86 is constructed as a four-lane divided (2-lanes per direction) highway.

Dogwood Road is classified as a Prime Arterial on the Imperial County Circulation Element. Dogwood Road is a north-south facility located east of the project site. In the vicinity of the project, Dogwood Road is constructed as a two-lane undivided roadway.

Keystone Road is classified as a Prime Arterial on the Imperial County Circulation Element. Keystone Road is a north-south facility located north of the project site. In the vicinity of the project, Keystone Road is constructed as a two-lane undivided roadway.

Harris Road is classified as a Major Collector on the Imperial County Circulation Element. Harris Road is a two-lane east-west facility which will provide direct access to the project site. In the vicinity of the project, Harris Road is a two-lane undivided roadway. It should be noted that west of SR-86, Harris Road is currently unpaved.

Barioni Boulevard / Worthington Road is classified as a Major Collector on the Imperial County Circulation Element. Worthington Road is a two-lane, east-west facility located south of the project site. It should be noted that Barioni Boulevard changes names to Worthington Road east of Dogwood Road.

It should be noted that no bike lanes were observed within the project vicinity.

3.2 Existing Traffic Volumes

Daily traffic (ADT) volumes on study area segments along SR-86 and SR-111 were obtained from the Caltrans Traffic Census Program for Year 2016, the latest available as of the date of this report. To be conservative, a 10% growth was applied to update the counts to Year 2018 conditions. AM and PM peak hour intersection turning movement volume counts at study area intersections were commissioned by LLG Engineers on August 23rd, 2018, while schools were in session. *Table 3-1* summarizes the segment ADT volumes on all the study area segments.

Figure 3-2 depicts the existing traffic volumes on both an ADT and peak hour basis. *Appendix A* contains the manual intersection count sheets and latest Caltrans traffic volumes.

**TABLE 3-1
EXISTING TRAFFIC VOLUMES**

Street Segment	Source	2018 ADT ^a
SR-86		
Keystone Road to Harris Road	Caltrans	14,850
Harris Road to Barioni Boulevard	Caltrans	14,850
SR-111		
Keystone Road to Harris Road	Caltrans	16,400
Harris Road to Worthington Road	Caltrans	16,400
Harris Road		
SR-86 to Dogwood Road	LLG	350
Dogwood Road to SR-111	LLG	370

Footnotes:

a. Average Daily Traffic Volume.

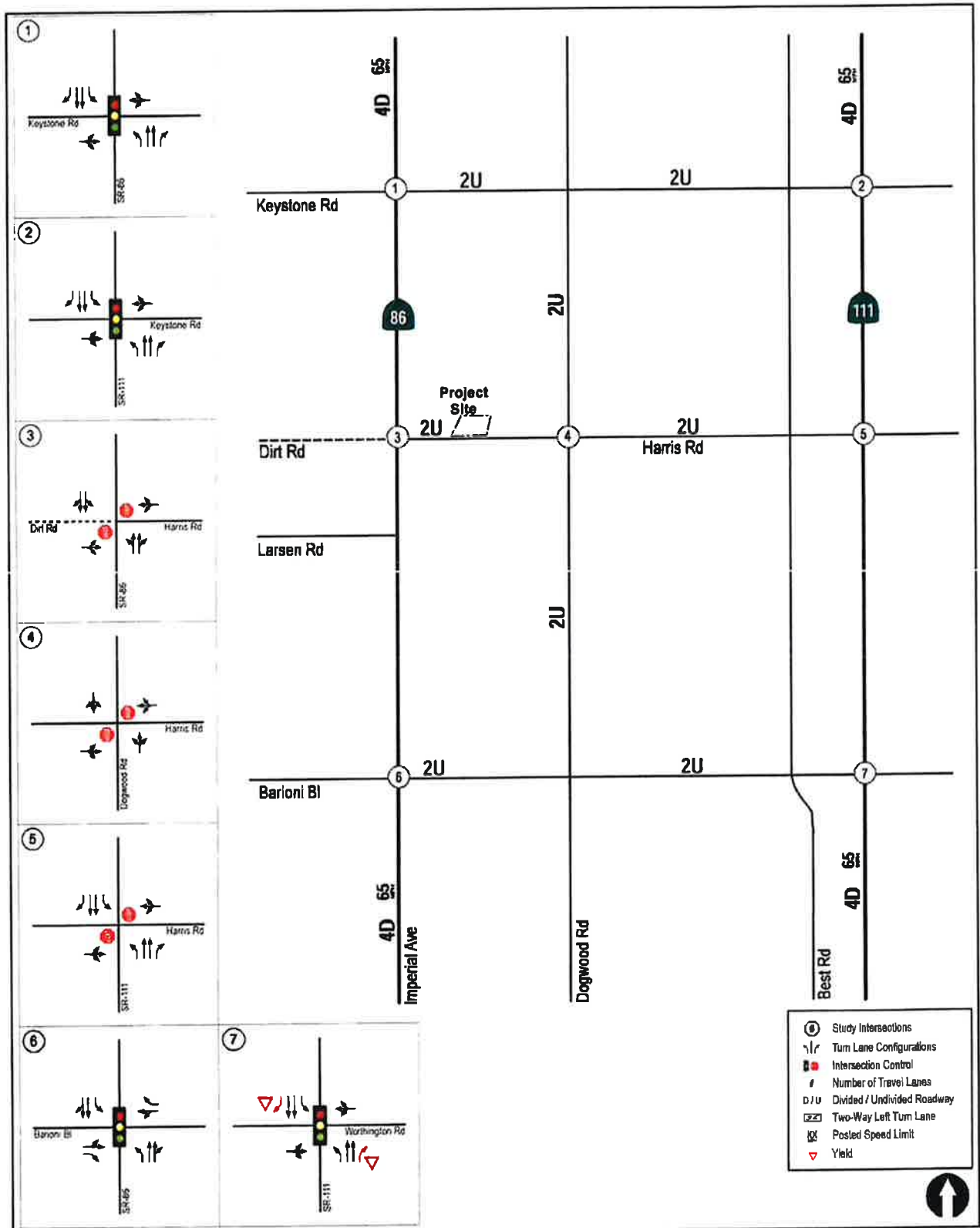

N:\2008\Figures
Date: 08/16/18

Figure 3-1

Existing Conditions Diagram

SIMPLOT FERTILIZER TERMINAL RELOCATION PROJECT

EEC ORIGINAL PKG

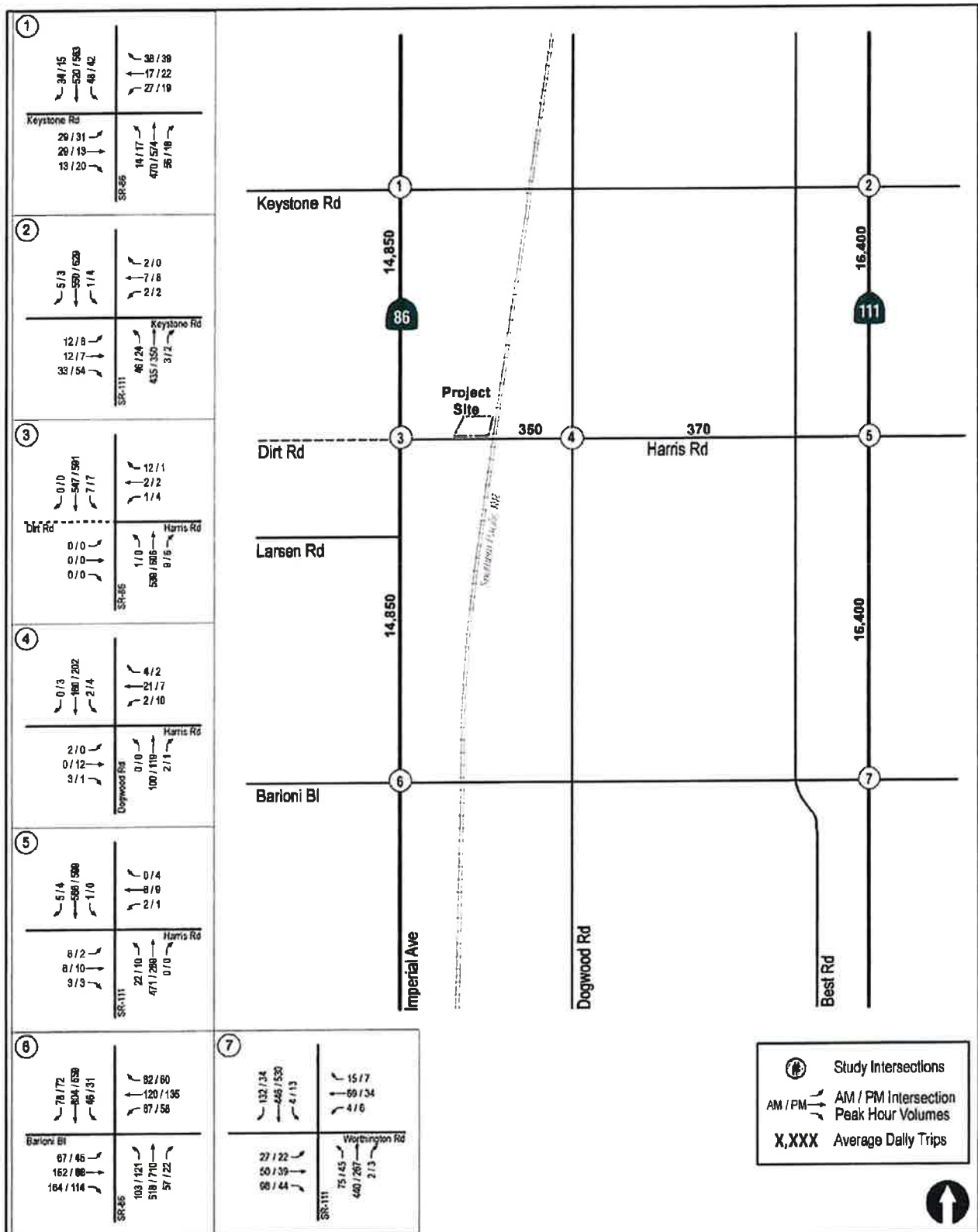

N:\2868\Figures
Date: 09/10/18



4.0 ANALYSIS APPROACH AND METHODOLOGY

Based on the anticipated distribution/assignment of project traffic, the intersections included in the study area are listed below.

Intersections

1. SR-86 / Keystone Road
2. SR-111/ Keystone Road
3. SR-86 / Harris Road
4. Dogwood Road / Harris Road
5. SR-111 / Harris Road
6. SR-86 / Barioni Boulevard
7. SR-111 / Worthington Road

Segments

SR-86: Keystone Road to Harris Road;
SR-86: Harris Road to Barioni Boulevard;
SR-111: Keystone Road to Harris Road;
SR-111: Harris Road to Worthington Road;
Harris Road: SR-86 to Dogwood Road; and
Harris Road: Dogwood Road to SR-111.

This report takes into account the effects of the heavy vehicle traffic associated with the project since this type of traffic is more impactful to the local circulation system than passenger cars (See Section 7.1).

The following scenarios are analyzed in this report.

- *Existing*
- *Existing + Project*
- *Existing + Project + Cumulative traffic*

The operations of the project area intersections and segments are characterized using the concept of "Level of Service" (LOS). LOS is the term used to denote the different operating conditions which occur on a given roadway segment under various traffic volume loads. It is a qualitative measure used to describe a quantitative analysis taking into account factors such as roadway geometries, signal phasing, speed, travel delay, freedom to maneuver, and safety. LOS provides an index to the operational qualities of a roadway segment or an intersection. LOS designations range from A through F, with LOS A representing the best operating conditions and LOS F representing the worst operating conditions. LOS designation is reported differently for signalized and unsignalized intersections, as well as for roadway segments.

Table 4-1 summarizes the level of service and delay in seconds per vehicle associated with each level of service.

4.1 Intersections

Signalized intersections were analyzed under weekday 7:00-9:00 AM and 4:00-6:00 PM peak hour conditions. Average vehicle delay was determined utilizing the methodology found in Chapter 18 of the *2016 Highway Capacity Manual (HCM 6th Edition)*, with the assistance of the *Synchro* (version 10) computer software. The delay values (represented in seconds) were qualified with a corresponding intersection LOS. A more detailed explanation of the methodology is attached in *Appendix B. Table 4-1* shows the signalized intersection delay categorized for each level of service (LOS).

Unsignalized intersections were analyzed under weekday 7:00-9:00 AM and 4:00-6:00 PM peak hour conditions. Average vehicle delay and Levels of Service (LOS) were determined based upon the procedures found in Chapters 19 and 20 of the *HCM 6*, with the assistance of the *Synchro* (version 10) computer software. A more detailed explanation of the methodology is attached in *Appendix B. Table 4-1* shows the unsignalized intersection delay categorized for each level of service (LOS).

TABLE 4-1
INTERSECTION LOS & DELAY RANGES

LOS	Delay (seconds/vehicle)	
	Signalized Intersections	Unsignalized Intersections
A	≤ 10.0	≤ 10.0
B	10.1 to 20.0	10.1 to 15.0
C	20.1 to 35.0	15.1 to 25.0
D	35.1 to 55.0	25.1 to 35.0
E	55.1 to 80.0	35.1 to 50.0
F	≥ 80.1	≥ 50.1

Source: 2010 Highway Capacity Manual

4.2 Street Segments

Street segments were analyzed based upon the comparison of ADT to the County of Imperial *Roadway Classifications, Levels of Service (LOS) and Average Daily Traffic (ADT)* table (see *Table 4-2* below). Segment analysis is a comparison of ADT volumes and an approximate daily capacity on the subject roadway.

**TABLE 4-2
IMPERIAL COUNTY STANDARD STREET CLASSIFICATION AVERAGE DAILY VEHICLE TRIPS**

Road		Level of Service W/ADT*				
Class	X-Section	A	B	C	D	E
Expressway	128 / 210	30,000	42,000	60,000	70,000	80,000
Prime Arterial	106 / 136	22,200	37,000	44,600	50,000	57,000
Minor Arterial	82 / 102	14,800	24,700	29,600	33,400	37,000
Major Collector (Collector)	64 / 84	13,700	22,800	27,400	30,800	34,200
Minor Collector (Local Collector)	40 / 70	1,900	4,100	7,100	10,900	16,200
Residential Street	40 / 60	*	*	< 1,500	*	*
Residential Cul-de- Sac / Loop Street	40/60	*	*	< 1,500	*	*
Industrial Collector	76 / 96	5,000	10,000	14,000	17,000	20,000
Industrial Local Street	44 / 64	2,500	5,000	7,000	8,500	10,000

* Levels of service are not applied to residential streets since their primary purpose is to serve abutting lots, not carry through traffic. Levels of service normally apply to roads carrying through traffic between major trip generators and attractors.

5.0 SIGNIFICANCE CRITERIA

The County of Imperial does not have published significance criteria. However, the County General Plan does state that the LOS goal for intersections and roadway segments is to operate at LOS C or better. Therefore, if an intersection or segment degrades from LOS C or better to LOS D or worse with the addition of project traffic, the impact is considered significant. If the location operates at LOS D or worse with and without project traffic, the impact is considered significant if the project causes the intersection delta to increase by more than two (2) seconds, or the volume to capacity (V/C) ratio to increase by more than 0.02.

A project is considered to have a significant impact if the new project traffic decreases the operations of surrounding roadways by a defined threshold. The defined thresholds for roadway segments and intersections are defined in *Table 5-1* below. If the project exceeds the thresholds in *Table 5-1*, then the project may be considered to have a significant project impact. A feasible mitigation measure will need to be identified to return the impact within the thresholds (pre-project + allowable increase) or the impact will be considered significant and unmitigated.

**TABLE 5-1
TRAFFIC IMPACT SIGNIFICANT THRESHOLDS**

Level of Service with Project ^a	Allowable Increase Due to Project Impacts ^b					
	Freeways		Roadway Segments		Intersections	Ramp Metering
	V/C	Speed (mph)	V/C	Speed (mph)	Delay (sec.)	Delay (min.)
D, E & F (or ramp meter delays above 15 minutes)	0.01	1	0.02	1	2	2 ^c

Footnotes:

- All level of service measurements are based upon HCM procedures for peak-hour conditions. However, V/C ratios for Roadway Segments may be estimated on an ADT/24-hour traffic volume basis (using Table 4-3 or a similar LOS chart for each jurisdiction). The acceptable LOS for freeways, roadways, and intersections is generally "D" ("C" for undeveloped or not densely developed locations per jurisdiction definitions). For metered freeway ramps, LOS does not apply. However, ramp meter delays above 15 minutes are considered excessive.
- If a proposed project's traffic causes the values shown in the table to be exceeded, the impacts are deemed to be significant. These impact changes may be measured from appropriate computer programs or expanded manual spreadsheets. The project applicant shall then identify feasible mitigations (within the Traffic Impact Study [TIS] report) that will maintain the traffic facility at an acceptable LOS. If the LOS with the proposed project becomes unacceptable (see note a above), or if the project adds a significant amount of peak hour trips to cause any traffic queues to exceed on- or off-ramp storage capacities, the project applicant shall be responsible for mitigating significant impact changes.
- The allowable increase in delay at a ramp meter with more than 15 minutes of delay and freeway LOS E is 2 minutes and at LOS F is 1 minute.

General Notes:

- V/C = Volume to Capacity Ratio
- Speed = Arterial speed measured in miles per hour
- Delay = Average stopped delay per vehicle measured in seconds for intersections, or minutes for ramp meters.
- LOS = Level of Service

6.0 ANALYSIS OF EXISTING CONDITIONS

6.1 Peak Hour Intersection Levels of Service

As seen in *Table 6-1*, all study area intersections are calculated to currently operate at LOS C or better during both the AM and PM peak hours.

Appendix B contains the peak hour intersection analysis worksheets.

**TABLE 6-1
EXISTING INTERSECTION OPERATIONS**

Intersection	Control Type	Peak Hour	Existing	
			Delay ^a	LOS ^b
1. SR 86 / Keystone Road	Signal	AM	8.3	A
		PM	8.1	A
2. SR 111 / Keystone Road	Signal	AM	6.4	A
		PM	6.4	A
3. SR-86 / Harris Road	TWSC ^c	AM	13.1	B
		PM	23.8	C
4. Dogwood Road / Harris Road	TWSC ^c	AM	8.3	A
		PM	8.3	A
5. SR 111 / Harris Road	TWSC ^c	AM	24.5	C
		PM	24.3	C
6. SR-86 / Barioni Boulevard	Signal	AM	29.0	C
		PM	24.4	C
7. SR-111 / Worthington Road	Signal	AM	11.5	B
		PM	9.1	A

Footnotes:

- a. Average delay expressed in seconds per vehicle.
- b. Level of Service.
- c. TWSC – Two-Way Stop Controlled intersection (Minor street turn delay is reported).

SIGNALIZED		UNSIGNALIZED	
Delay	LOS	Delay	LOS
0.0 ≤ 10.0	A	0.0 ≤ 10.0	A
10.1 to 20.0	B	10.1 to 15.0	B
20.1 to 35.0	C	15.1 to 25.0	C
35.1 to 45.0	D	25.1 to 35.0	D
45.1 to 80.0	E	35.1 to 50.0	E
> 80.1	F	≥ 50.1	F

6.2 Daily Street Segment Levels of Service

As seen in *Table 6-2*, all study area segments are calculated to currently operate at LOS B or better on a daily basis.

**TABLE 6-2
EXISTING STREET SEGMENT OPERATIONS**

Street Segment	Capacity (LOS E) ^a	ADT ^b	LOS ^c	V/C ^d
SR-86				
Keystone Road to Harris Road	34,200	14,850	B	0.434
Harris Road to Barioni Boulevard	34,200	14,850	B	0.434
SR-111				
Keystone Road to Harris Road	37,000	16,400	B	0.443
Harris Road to Worthington Road	37,000	16,400	B	0.443
Harris Road				
SR-86 to Dogwood Road	16,200	350	A	0.022
Dogwood Road to SR-111	16,200	370	A	0.023

Footnotes:

- a. Roadway capacity corresponding to Level of Service E from Imperial County Standard Street Classification, Average Daily Vehicle Trips table.
- b. Average Daily Traffic volumes
- c. Level of Service
- d. Volume / Capacity ratio.

7.0 TRIP GENERATION/DISTRIBUTION/ASSIGNMENT

7.1 Trip Generation

The project will generate traffic in terms of employee trips and trucks hauling raw material from the project site to Hotville, Brawley, Imperial, Calipatria, Westmorland and El Centro. A maximum of 20 truck trips are estimated to be generated to ship fertilizer to the recipients. A total of 7 employees are expected to work with a shift of approximately 7 AM to 4 PM.

Passenger Car Equivalence (PCE) is defined as the number of passenger cars that are displaced by a single heavy vehicle of a particular type under the prevailing traffic conditions. Heavy vehicles have a greater traffic impact than passenger cars since:

- They are larger than passenger cars, and therefore, occupy more roadway space; and
- Their performance characteristics are generally inferior to passenger cars, leading to the formation of downstream gaps in the traffic stream (especially on upgrades), which cannot always be effectively filled by normal passing maneuvers.

Much of the project-generated traffic consists of heavy vehicles (trucks). Therefore, a PCE factor of 2.0 per truck was applied to the generated truck trips.

Table 7-1 shows the total project traffic generation based on the information described above. The total project is calculated to generate approximately 108 ADT (with PCE factor) with 15 inbound / 9 outbound trips during the AM peak hour and 9 inbound / 15 outbound trips during the PM peak hour.

TABLE 7-1
TRIP GENERATION

Vehicle Type	Daily Inbound Vehicles	Rate	ADT	PCE Value	ADT With PCE	AM Peak Hour		PM Peak Hour	
						In	Out	In	Out
1 Delivery Trucks	20	2*	40	2.0	80	8	8	8	8
2. Staff	7	4**	28	1.0	28	7	1	1	7
Total	27	-	68	-	108	15	9	9	15

Footnotes:

Site specific rates based on number of employees and trucks

Assuming all employees enter and leave the site during peak commuter hours and:

* Assumes each truck enters and exits the site (2 trips).

** Assumes each employee leaves the site once during each day.

The Highway Capacity Manual indicates a Passenger Car Equivalence (PCE) of 2.0 for trucks on level terrain.

7.2 Trip Distribution/Assignment

Separate trip distributions were completed for employee and truck trips. The employee distribution was estimated based on a) proximity to state highways, arterials, and freeways; b) the location of local schools, businesses, and housing; and c) study area roadway characteristics. Truck distribution is based on the truck route information provided by the applicant.

It should be noted that outbound trucks would utilize slightly alternative routes than inbound trucks.

Figures 7-1 & 7-2 shows the regional trip distribution for truck trips and employee trips, respectively. The project traffic was assigned to the street system based on these distributions. *Figure 7-3* depicts the project traffic volume assignment for trucks, *Figure 7-4* represents the project traffic volume assignment for employees, *Figure 7-5* represents the total project traffic volumes and *Figure 7-6* shows the existing + total project traffic volumes.

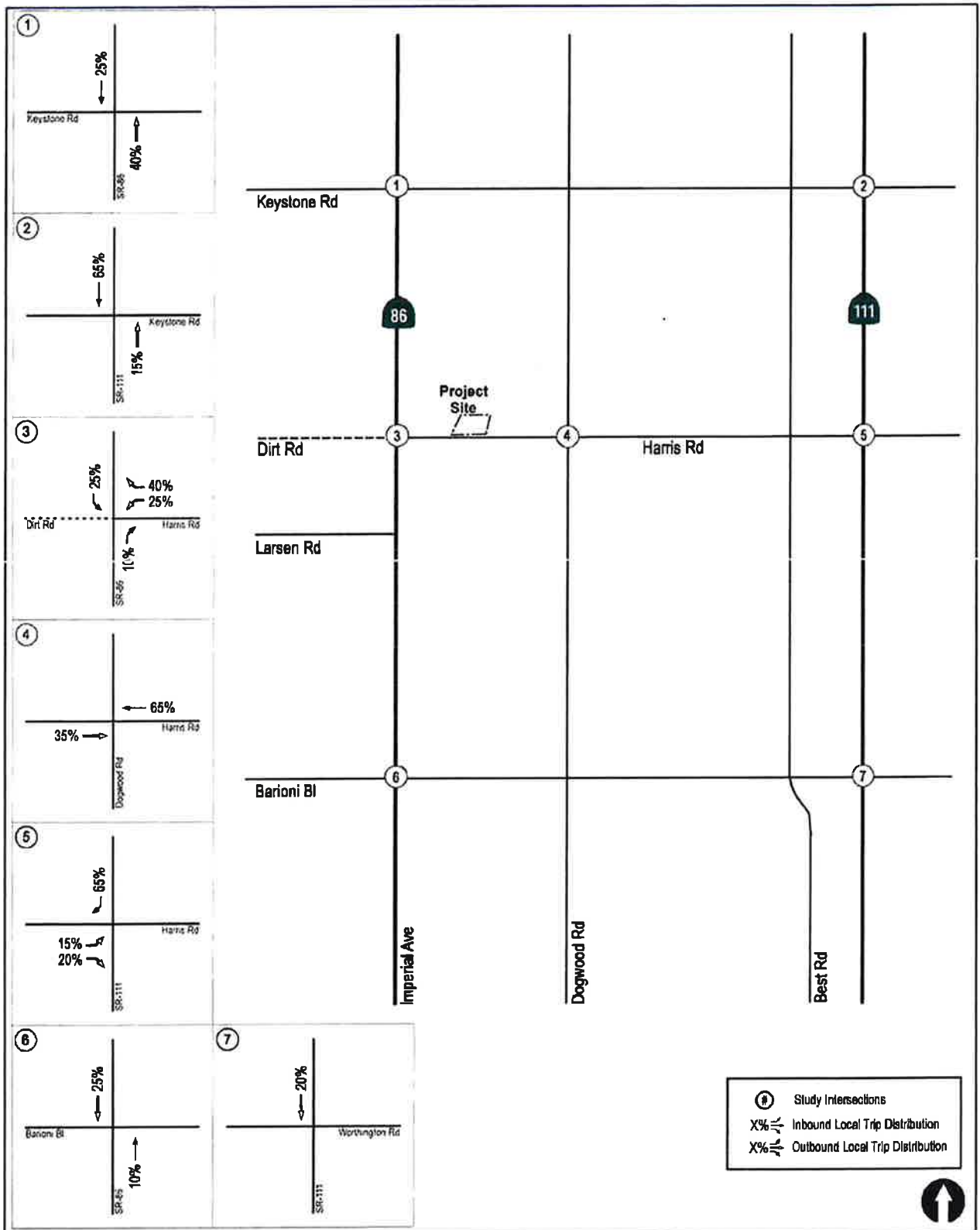

Figure 7-1

**Project Traffic Distribution
Truck Trips**

SIMPLOT FERTILIZER TERMINAL RELOCATION PROJECT

EEC ORIGINAL PKG

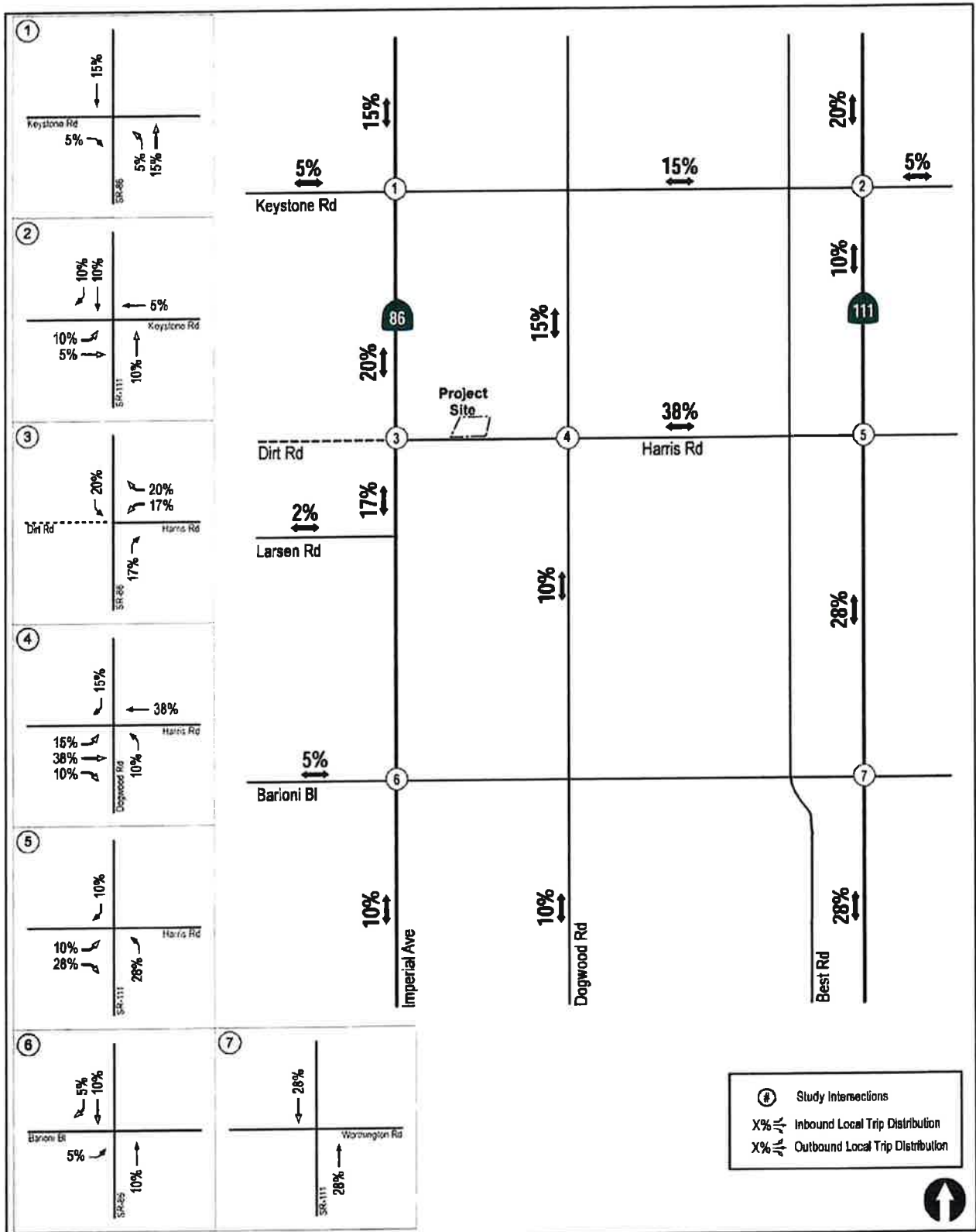
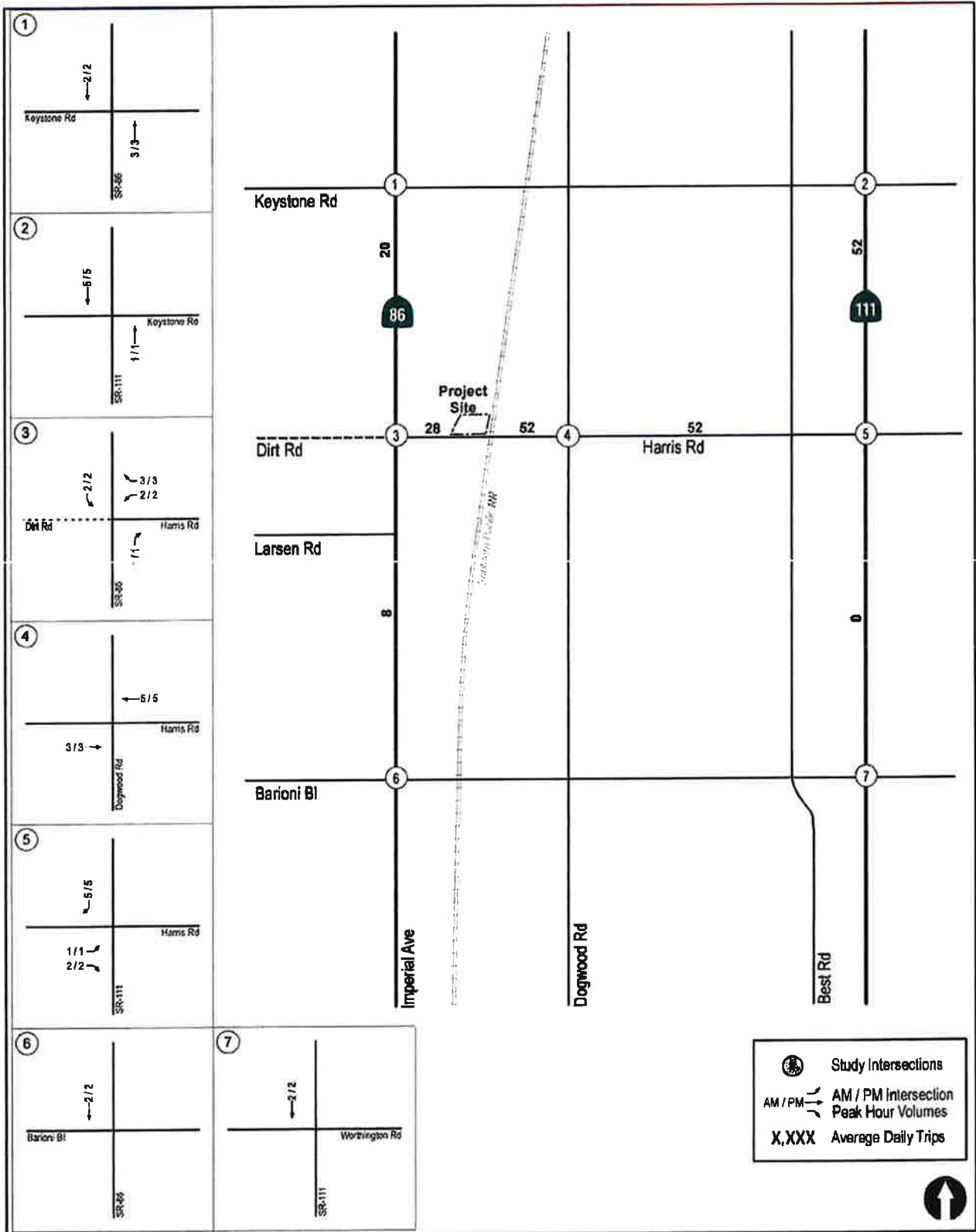

Figure 7-2

Project Traffic Distribution
Employee Trips

SIMPLOT FERTILIZER TERMINAL RELOCATION PROJECT



N:\2966\Figures
Date: 08/18/18



Figure 7-3
Project Traffic Volumes
Truck Trips

SIMPLOT FERTILIZER TERMINAL RELOCATION PROJECT

EEC ORIGINAL PKG

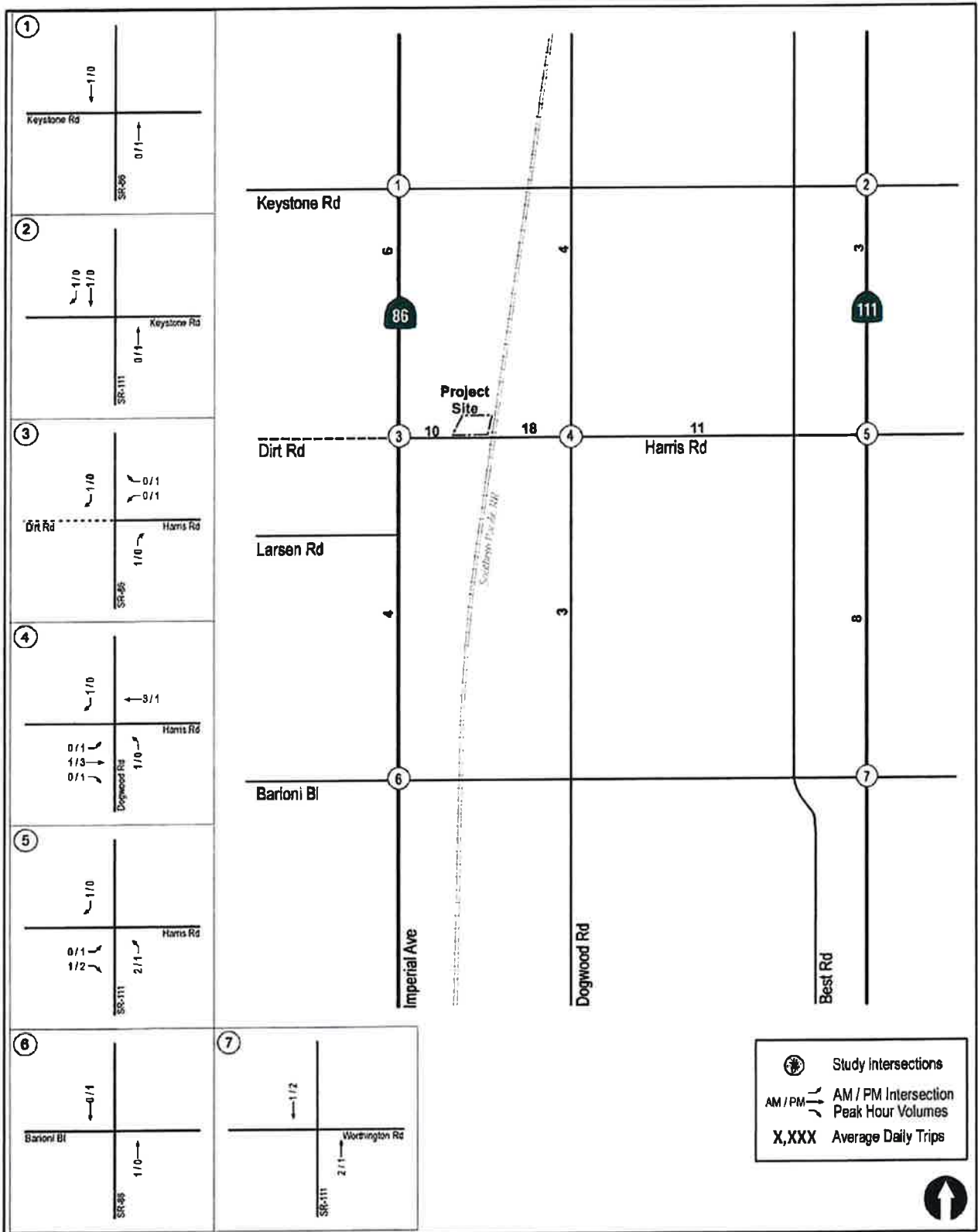

NA2060/Figures
Date: 08/10/18



Figure 7-4
Project Traffic Volumes
Employee Trips

SIMPLOT FERTILIZER TERMINAL RELOCATION PROJECT

EEC ORIGINAL PKG

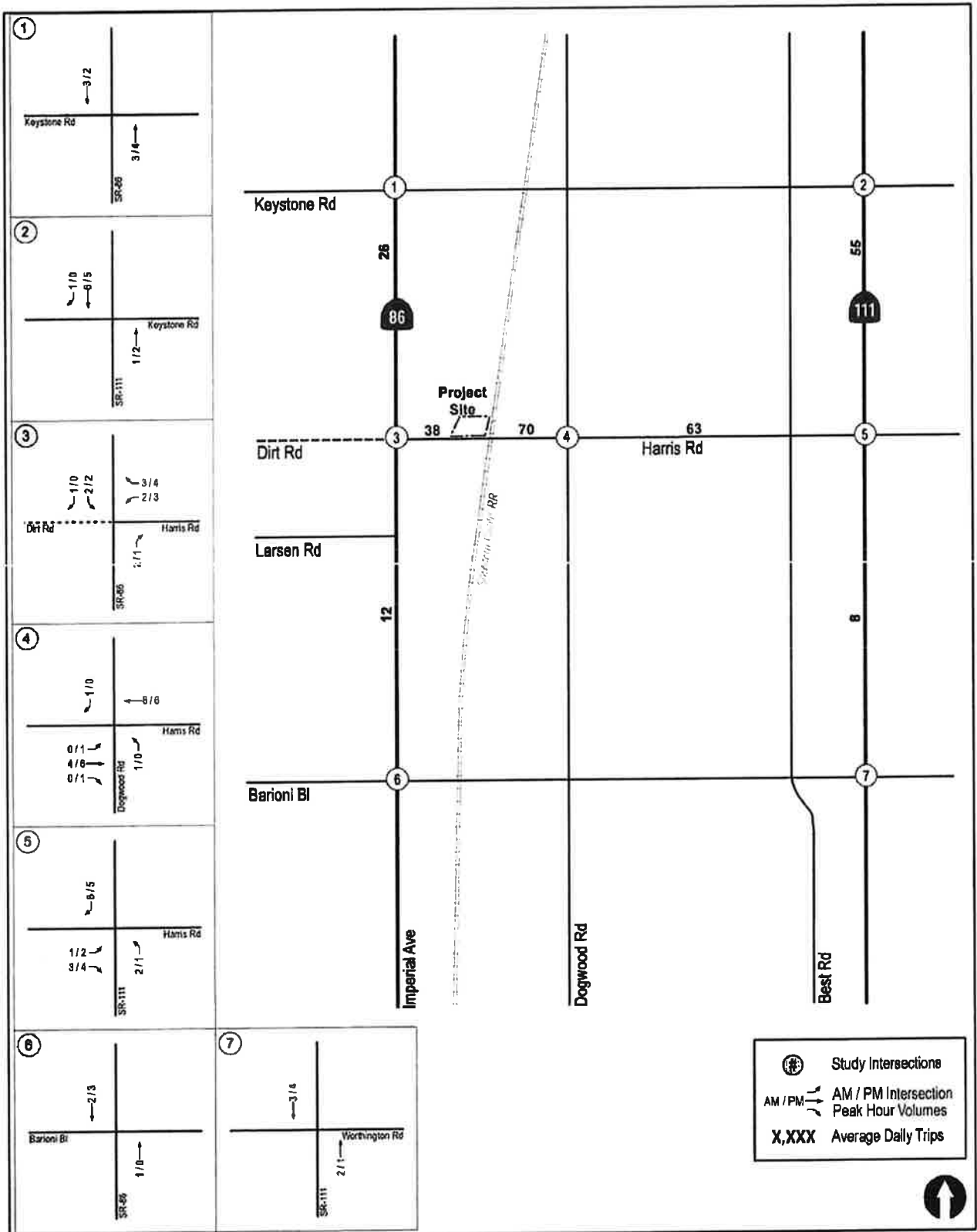

Figure 7-5

Total Project Traffic Volumes

SIMPLOT FERTILIZER TERMINAL RELOCATION PROJECT

EEC ORIGINAL PKG

UNSCD
EAGLE
GEOGRAPHIC
ENGINEERING

N:\2008\Figures
Date: 09/10/18

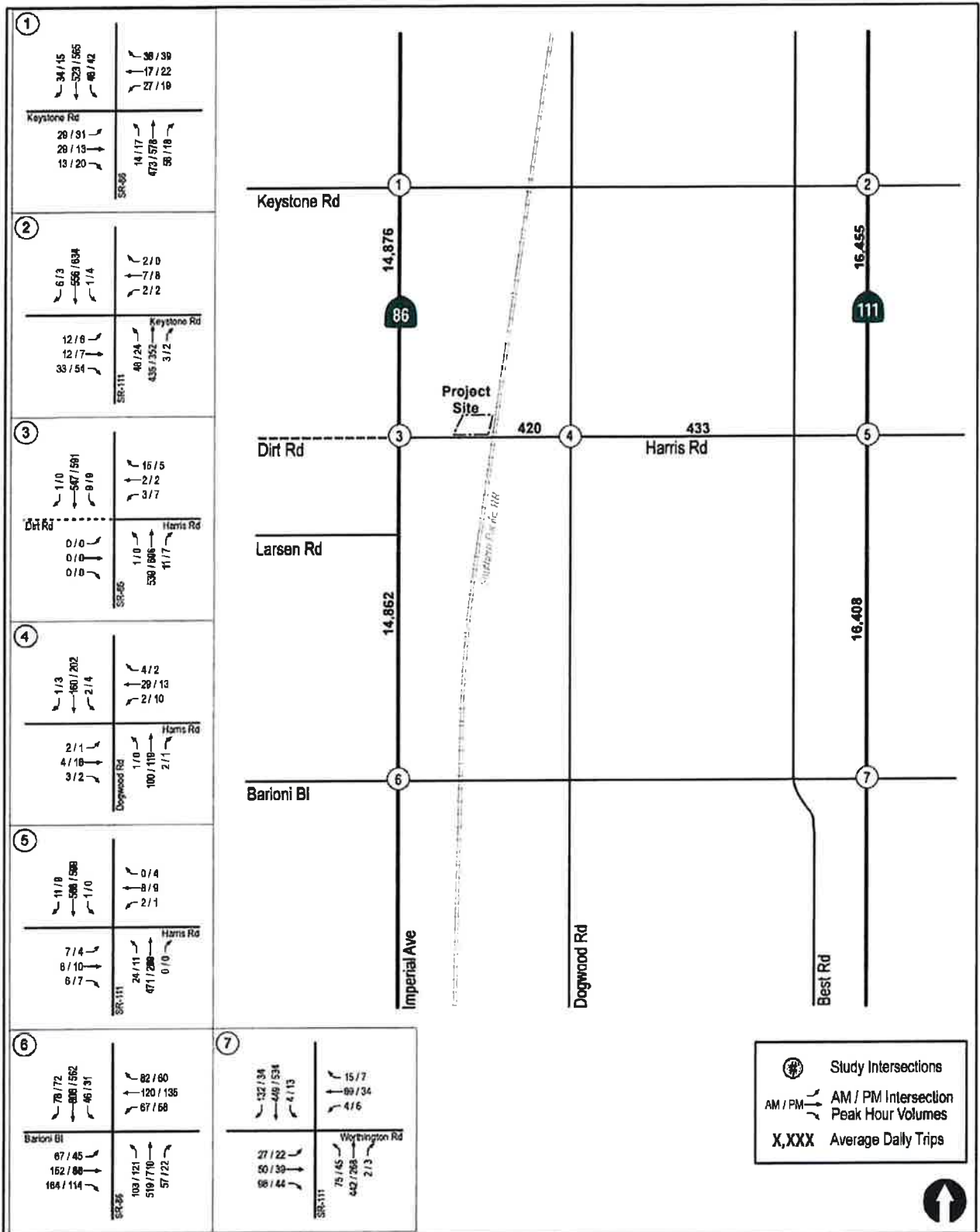

Figure 7-6

Existing + Total Project Traffic Volumes

SIMPLOT FERTILIZER TERMINAL RELOCATION PROJECT

EEC ORIGINAL PKG

8.0 CUMULATIVE

There are no significant planned projects in the area adjacent to the project site that may add traffic to the surrounding roadways. Therefore to account for any unforeseen increase in traffic, a 10% growth factor was applied to the existing traffic volumes to account for cumulative traffic.

Figure 8-1 depicts the Existing + Total Project + Cumulative.

8.1 Existing + Total Project Analysis

8.1.1 Intersection Operations

Table 8-1 summarizes the intersection operations throughout the project study area with the addition of project traffic. *Table 8-1* shows that all of the intersections in the study area are calculated to operate at LOS C or better during the AM and PM peak hours.

8.1.2 Segment Analysis

Table 8-2 summarizes the street segment operations throughout the project study area with the addition of project traffic. *Table 8-2* shows that all of the street segments in the study area are forecasted to operate at LOS B or better on a daily basis.

8.2 Existing + Total Project + Cumulative Analysis

8.2.1 Intersection Analysis

Table 8-1 summarizes the intersection operations throughout the project study area with the addition of cumulative growth. *Table 8-1* shows that all of the intersections in the study area are calculated to continue to operate at LOS C or better during the AM and PM peak hours.

8.2.2 Segment Analysis

Table 8-2 summarizes the street segment operations throughout the project study area with the addition of cumulative traffic. *Table 8-2* shows that all of the street segments in the study area are forecasted to continue to operate at LOS B or better on a daily basis.

**TABLE 8-1
NEAR-TERM INTERSECTION OPERATIONS**

Intersection	Control Type	Peak Hour	Existing + Total Project		Existing + Total Project + Cumulative		Significant?
			Delay ^a	LOS ^b	Delay	LOS	
1. SR-86 / Keystone Road	Signal	AM	8.3	A	8.7	A	No
		PM	8.1	A	8.3	A	No
2. SR-111 / Keystone Road	Signal	AM	6.4	A	6.6	A	No
		PM	6.4	A	6.4	A	No
3. SR-86 / Harris Road	TWSC ^c	AM	13.7	B	14.6	B	No
		PM	20.6	C	23.7	C	No
4. Dogwood Road / Harris Road	TWSC	AM	8.4	A	8.4	A	No
		PM	8.3	A	8.3	A	No
5. SR-111 / Harris Road	TWSC	AM	24.4	C	24.4	C	No
		PM	24.1	C	24.1	C	No
6. SR-86 / Barioni Boulevard	Signal	AM	29.0	C	32.8	C	No
		PM	24.4	C	28.3	C	No
7. SR-111 / Worthington Road	Signal	AM	11.5	B	12.0	B	No
		PM	9.1	A	9.3	A	No

Footnotes:

- a. Average delay expressed in seconds per vehicle.
- b. Level of Service.
- c. TWSC – Two-Way Stop Controlled intersection (Minor street turn delay is reported).

SIGNALIZED		UNSIGNALIZED	
Delay	LOS	Delay	LOS
0.0 ≤ 10.0	A	0.0 ≤ 10.0	A
10.1 to 20.0	B	10.1 to 15.0	B
20.1 to 35.0	C	15.1 to 25.0	C
35.1 to 45.0	D	25.1 to 35.0	D
45.1 to 80.0	E	35.1 to 50.0	E
≥ 80.1	F	≥ 50.1	F

**TABLE 8-2
NEAR-TERM STREET SEGMENT OPERATIONS**

Street Segment	Existing Capacity (LOS E) ^a	Existing + Project			Existing + Project + Cumulative		
		ADT ^b	LOS ^c	V/C ^d	ADT	LOS	V/C
SR-86							
Keystone Road to Harris Road	34,200	14,876	0.435	B	16,361	B	0.478
Harris Road to Barioni Boulevard	34,200	14,862	0.435	B	16,347	B	0.478
SR-111							
Keystone Road to Harris Road	37,000	16,455	0.445	B	18,095	B	0.489
Harris Road to Worthington Road	37,000	16,408	0.443	B	18,048	B	0.488
Harris Road							
SR-86 to Dogwood Road	16,200	420	0.026	A	455	A	0.03
Dogwood Road to SR-111	16,200	433	0.027	A	470	A	0.03

Footnotes:

- a. Roadway capacity corresponding to Level of Service E from Imperial County Standard Street Classification, Average Daily Vehicle Trips table
- b. Average Daily Traffic volumes
- c. Level of Service
- d. Volume / Capacity ratio

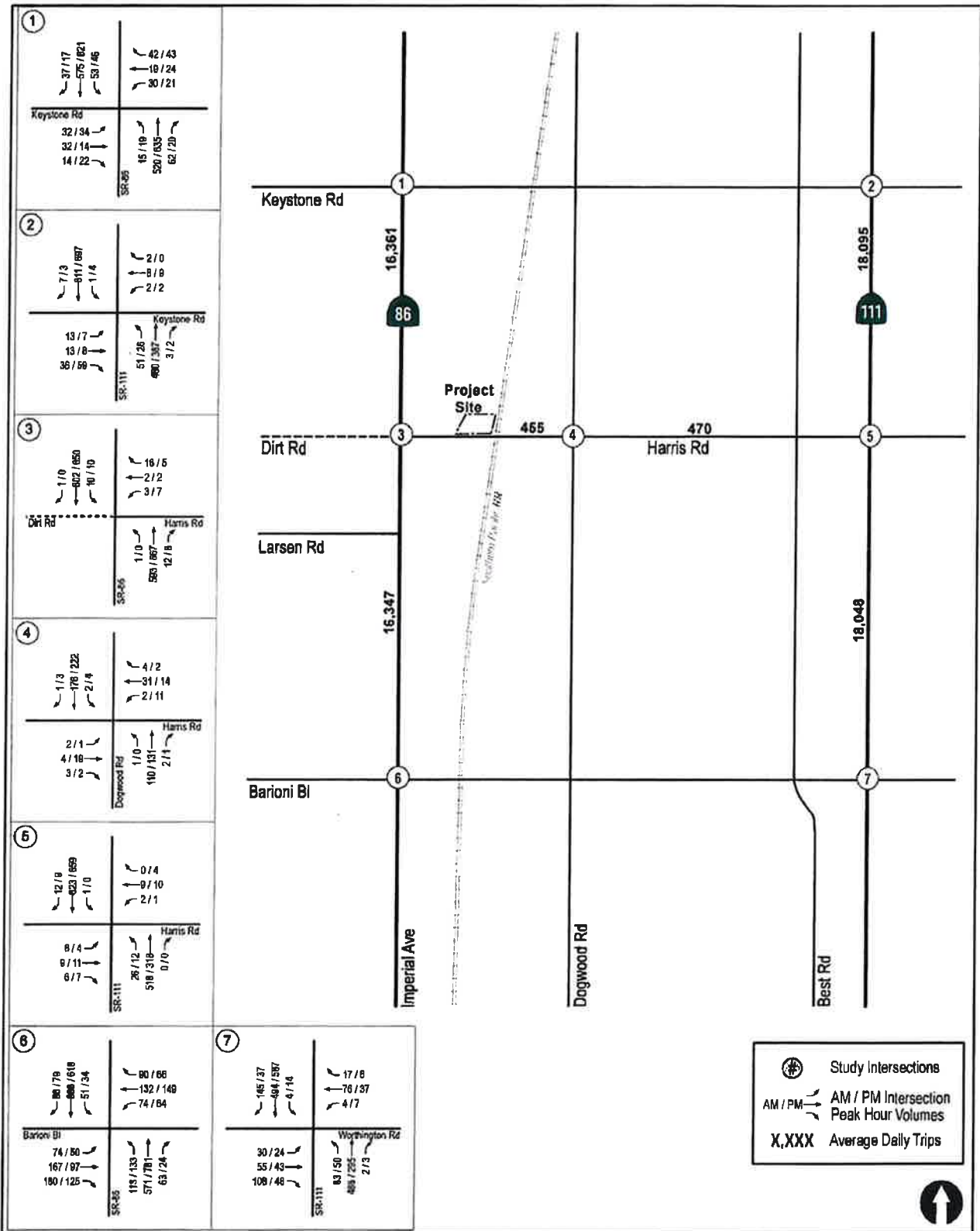

N:\2968\Figures
Date: 04/16/19

Figure 8-1

Existing + Total Project + Cumulative Traffic Volumes

SIMPLOT FERTILIZER TERMINAL RELOCATION PROJECT



9.0 PROJECT ACCESS

The Project will provide one (1) main access driveway to Harris Road with a secondary "Emergency Access only" gated driveway also provided just west of the main access driveway. Based on the location of the driveway, the relatively low amount of project trips, and the very low traffic volumes along Harris Road, the driveway should perform adequately.

10.0 CONCLUSIONS & RECOMMENDATIONS

The capacity analyses performed for the key roadway segments and study area intersections indicate that *no significant impacts would occur* due to the project. Therefore, mitigation measures are not necessary.

Transportation Impact Analysis (dated September 14, 2019)

EEC ORIGINAL PKG

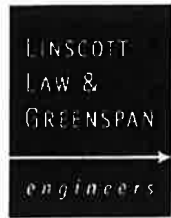

TRANSPORTATION IMPACT ANALYSIS
SIMPLOT-FERTILIZER TERMINAL
RELOCATION PROJECT
County of Imperial, California
September 14, 2018

LLG Ref. 3-18-2968

Prepared by:
Jose Nunez
Transportation Planner II

Under the Supervision of:
John A. Boarman
Principal

**Linscott, Law &
Greenspan, Engineers**
4542 Rufner Street
Suite 100
San Diego, CA 92111
858.300.8800 T
858.300.8810 F
www.llgengineers.com

EEC ORIGINAL PKG

TABLE OF CONTENTS

SECTION	PAGE
Appendices	ii
List of Figures	iii
List of Tables	iv
1.0 Introduction	5
2.0 Project Description	6
2.1 Project Location	6
2.2 Project Description.....	6
2.3 Project Access	6
3.0 Existing Conditions	10
3.1 Existing Street Network.....	10
3.2 Existing Traffic Volumes.....	10
4.0 Analysis Approach and Methodology	14
4.1 Intersections	15
4.2 Street Segments.....	15
5.0 Significance Criteria	17
6.0 Analysis of Existing Conditions	18
6.1 Peak Hour Intersection Levels of Service.....	18
6.2 Daily Street Segment Levels of Service	19
7.0 Trip Generation/Distribution/Assignment	20
7.1 Trip Generation.....	20
7.2 Trip Distribution/Assignment	21
8.0 Cumulative	28
8.1 Existing + Total Project Analysis	28
8.1.1 Intersection Operations	28
8.1.2 Segment Analysis.....	28
8.2 Existing + Total Project + Cumulative Analysis	28
8.2.1 Intersection Analysis.....	28
8.2.2 Segment Analysis.....	28
9.0 Project Access	32

10.0 Conclusions & Recommendations..... 33

APPENDICES

APPENDIX

- A. Intersection Count Sheets & Caltrans Traffic Volumes**
- B. Peak Hour Intersection Analysis Worksheets**

LIST OF FIGURES

SECTION—FIGURE #	PAGE
Figure 2-1 Vicinity Map	7
Figure 2-2 Project Area Map	8
Figure 2-3 Site Plan	9
Figure 3-1 Existing Conditions Diagram.....	12
Figure 3-2 Existing Traffic Volumes.....	13
Figure 7-1 Project Distribution – Truck Trips	22
Figure 7-2 Project Distribution – Employee/Miscellaneous Trips	23
Figure 7-3 Project Traffic Volumes – Truck Trips.....	24
Figure 7-4 Project Traffic Volumes – Employee/Miscellaneous Trips.....	25
Figure 7-5 Project Traffic Volumes – Total Trips.....	26
Figure 7-6 Existing + Total Project Traffic Volumes.....	27
Figure 8-1 Existing + Total Project + Cumulative Traffic Volumes.....	31

LIST OF TABLES

SECTION—TABLE #	PAGE
Table 3-1 Existing Traffic Volumes.....	11
Table 4-1 Intersection LOS & Delay Ranges.....	15
Table 4-2 Imperial County Standard Street Classification Average Daily Vehicle Trips	16
Table 5-1 Traffic Impact Significant Thresholds.....	17
Table 6-1 Existing Intersection Operations.....	18
Table 6-2 Existing Street Segment Operations	19
Table 7-1 Trip Generation.....	20
Table 8-1 Near-Term Intersection Operations	29
Table 8-2 Near-Term Street Segment Operations.....	30

TRANSPORTATION IMPACT ANALYSIS
SIMPLOT-FERTILIZER TERMINAL
RELOCATION PROJECT
County of Imperial, California
September 14, 2018

1.0 INTRODUCTION

The following traffic impact analysis has been prepared to determine the potential transportation impacts to the local circulation system due to the Simplot-Fertilizer Terminal Relocation project. The site is located north of Harris Road, immediately west of the railroad tracks and a quarter mile east of SR 86 within the Mesquite Lake Specific Plan Area in the County of Imperial.

This report includes the following sections:

- Project Description
- Existing Conditions
- Analysis Approach and Methodology
- Significance Criteria
- Analysis of Existing Conditions
- Trip Generation / Distribution / Assignment
- Near-Term / Roadway Capacity Analysis
- Project Access discussion
- Conclusions and Recommendations

2.0 PROJECT DESCRIPTION

2.1 Project Location

The 40-acre Jr. Simplot-Fertilizer site is located north of Harris Road, immediately west of the railroad tracks and a quarter mile east of SR 86 in the County of Imperial. The project site is zoned ML-I-2 (Medium-Industrial) and is within the Mesquite Lake Specific Plan.

Figure 2-1 depicts the project vicinity. *Figure 2-2* shows a more detailed project area map. *Figure 2-3* shows the site plan.

2.2 Project Description

The applicant proposes to relocate its fertilizer warehouse/terminal where fertilizer will be received, warehoused, and shipped. The project site will receive both solid and liquid fertilizers via rail (Southern Pacific railroad) and distribute the fertilizer via trucks. The facility will have the capacity to store eight different dry/solid product segregations, and 15,000 tons of four different product segregations of liquid fertilizer. Both the liquid and solid fertilizer will be shipped via truck to recipients.

This transportation study will analyze the potential impacts of these additional trucks to the surrounding street system.

2.3 Project Access

Access to the project site will be via one (1) driveway to Harris Road. A secondary "Emergency Access only" gated driveway will also be provided to the west of the main access driveway.

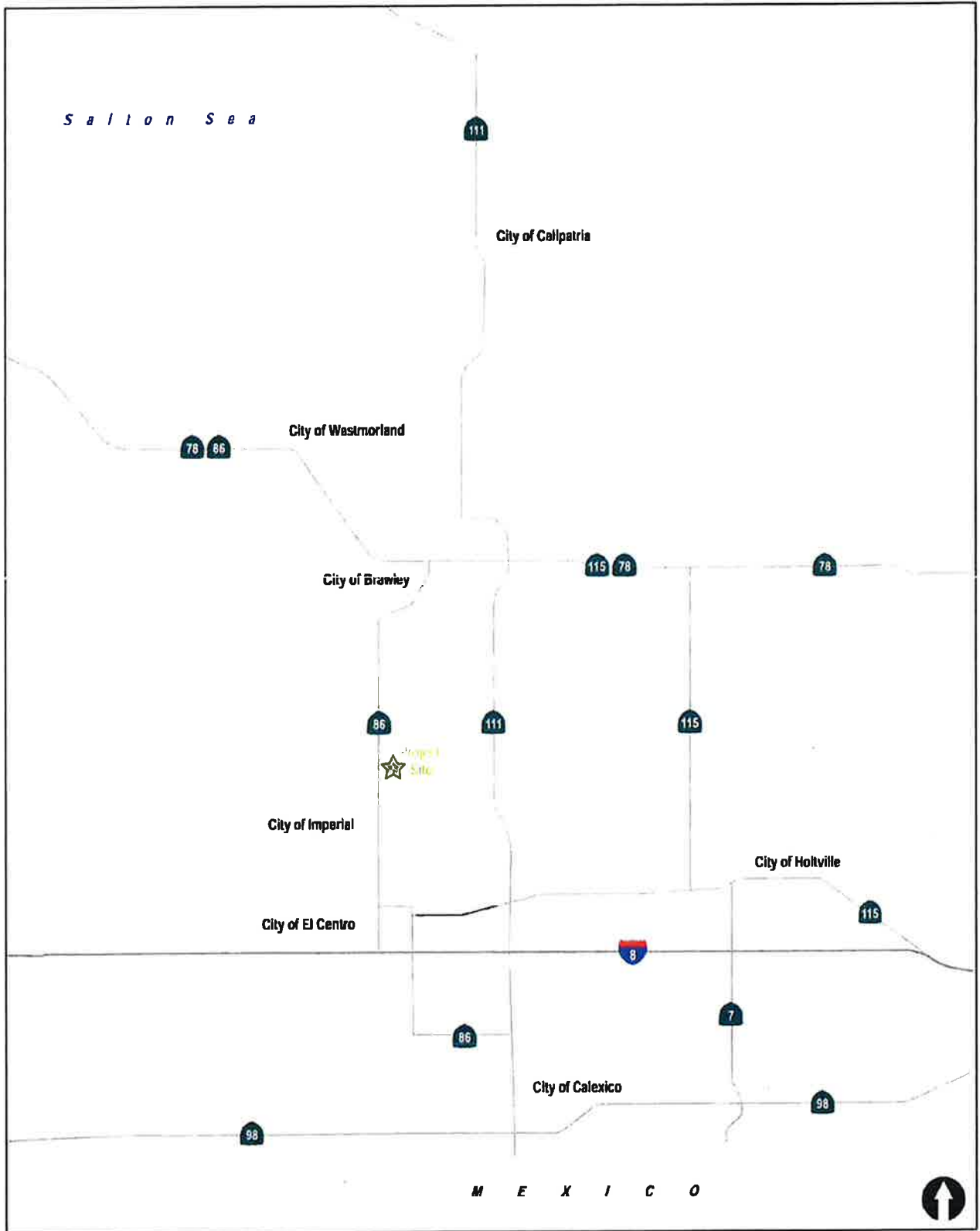

N:\2956\Figures
Data: 03/16/18

Figure 2-1

Vicinity Map

SIMPLOT FERTILIZER TERMINAL RELOCATION PROJECT

EEC ORIGINAL PKG

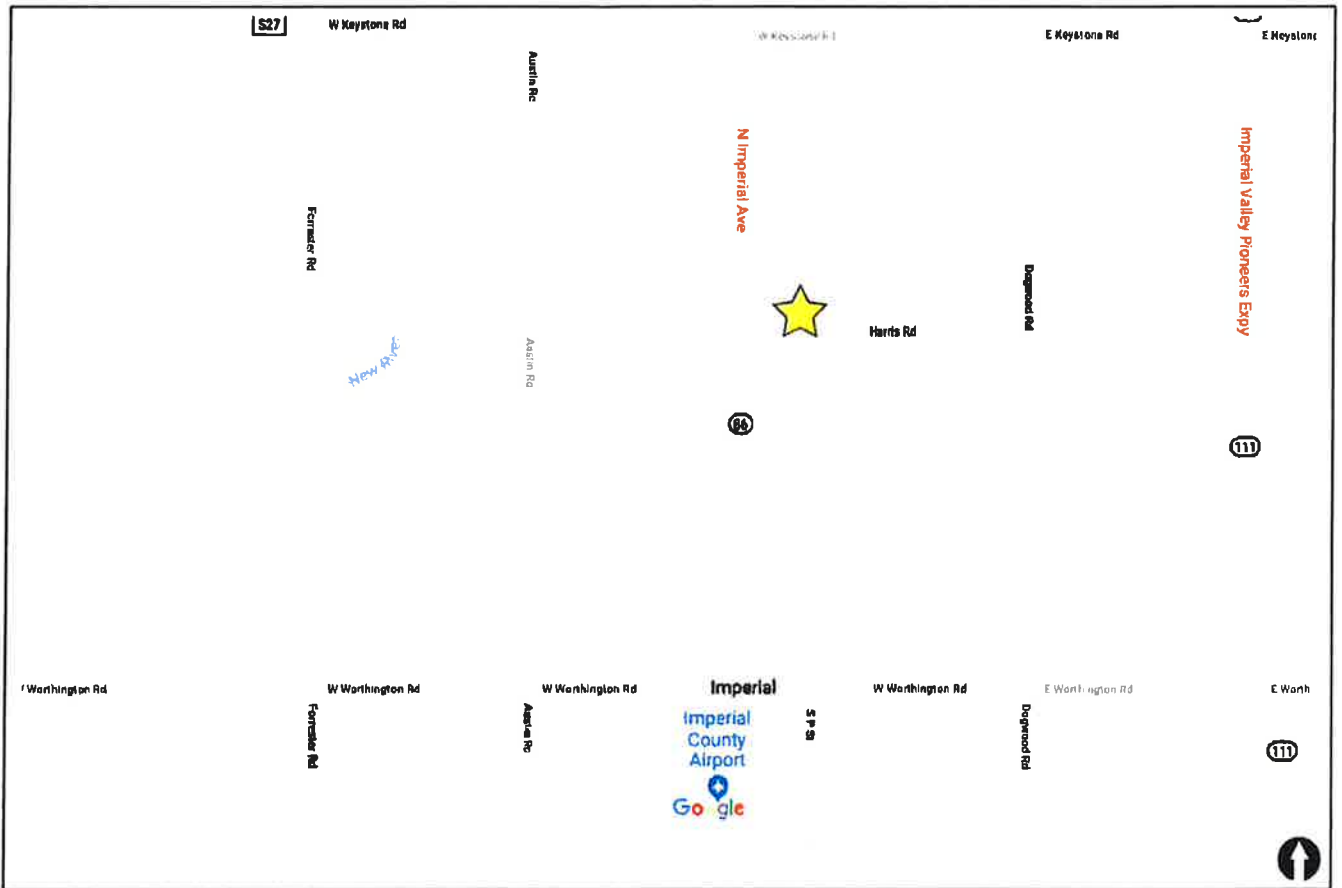

ERSCOTT
 LAM &
 GREENSPAN
 ENGINEERS
 N. 12960 Figures
 Date: 09/10/18

Figure 2-2

Project Area Map

SIMPLOT FERTILIZER TERMINAL RELOCATION PROJECT

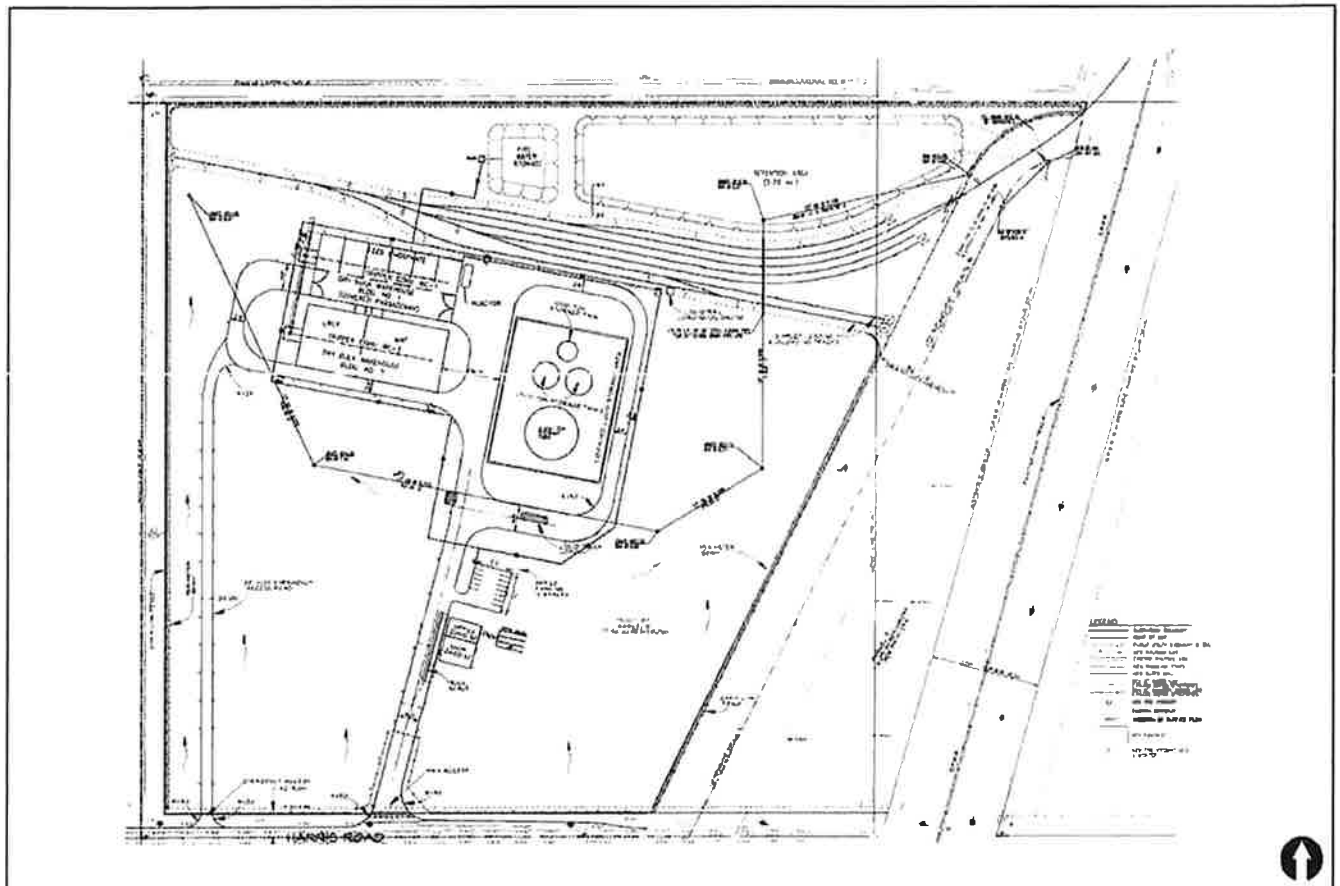

TOWN OF
 L.A. &
 GREYHOUND
 PROJECT

N:\2068\Figures
 Date: 09/10/18

Figure 2-3

Site Plan

SIMPLOT FERTILIZER TERMINAL RELOCATION PROJECT

3.0 EXISTING CONDITIONS

3.1 Existing Street Network

Following is a brief description of the street segments within the project area. *Figure 3-1* illustrates the existing conditions, including the lane geometry, for the key intersections in the study area.

State Route 111 (SR-111) is classified as a State Highway on the Imperial County Circulation Element. SR 111 is a north-south facility located east of the project site. In the vicinity of the project, SR-111 is constructed as a four-lane divided (2-lanes per direction) highway.

State Route 86 (SR-86) is classified as a State Highway on the Imperial County Circulation Element. SR 86 is a north-south facility located west of the project site. In the vicinity of the project, SR-86 is constructed as a four-lane divided (2-lanes per direction) highway.

Dogwood Road is classified as a Prime Arterial on the Imperial County Circulation Element. Dogwood Road is a north-south facility located east of the project site. In the vicinity of the project, Dogwood Road is constructed as a two-lane undivided roadway.

Keystone Road is classified as a Prime Arterial on the Imperial County Circulation Element. Keystone Road is a north-south facility located north of the project site. In the vicinity of the project, Keystone Road is constructed as a two-lane undivided roadway.

Harris Road is classified as a Major Collector on the Imperial County Circulation Element. Harris Road is a two-lane east-west facility which will provide direct access to the project site. In the vicinity of the project, Harris Road is a two-lane undivided roadway. It should be noted that west of SR-86, Harris Road is currently unpaved.

Barioni Boulevard / Worthington Road is classified as a Major Collector on the Imperial County Circulation Element. Worthington Road is a two-lane, east-west facility located south of the project site. It should be noted that Barioni Boulevard changes names to Worthington Road east of Dogwood Road.

It should be noted that no bike lanes were observed within the project vicinity.

3.2 Existing Traffic Volumes

Daily traffic (ADT) volumes on study area segments along SR-86 and SR-111 were obtained from the Caltrans Traffic Census Program for Year 2016, the latest available as of the date of this report. To be conservative, a 10% growth was applied to update the counts to Year 2018 conditions. AM and PM peak hour intersection turning movement volume counts at study area intersections were commissioned by LLG Engineers on August 23rd, 2018, while schools were in session. *Table 3-1* summarizes the segment ADT volumes on all the study area segments.

Figure 3-2 depicts the existing traffic volumes on both an ADT and peak hour basis. *Appendix A* contains the manual intersection count sheets and latest Caltrans traffic volumes.

**TABLE 3-1
EXISTING TRAFFIC VOLUMES**

Street Segment	Source	2018 ADT ^a
SR-86		
Keystone Road to Harris Road	Caltrans	14,850
Harris Road to Barioni Boulevard	Caltrans	14,850
SR-111		
Keystone Road to Harris Road	Caltrans	16,400
Harris Road to Worthington Road	Caltrans	16,400
Harris Road		
SR-86 to Dogwood Road	LLG	350
Dogwood Road to SR-111	LLG	370

Footnotes:

a. Average Daily Traffic Volume.

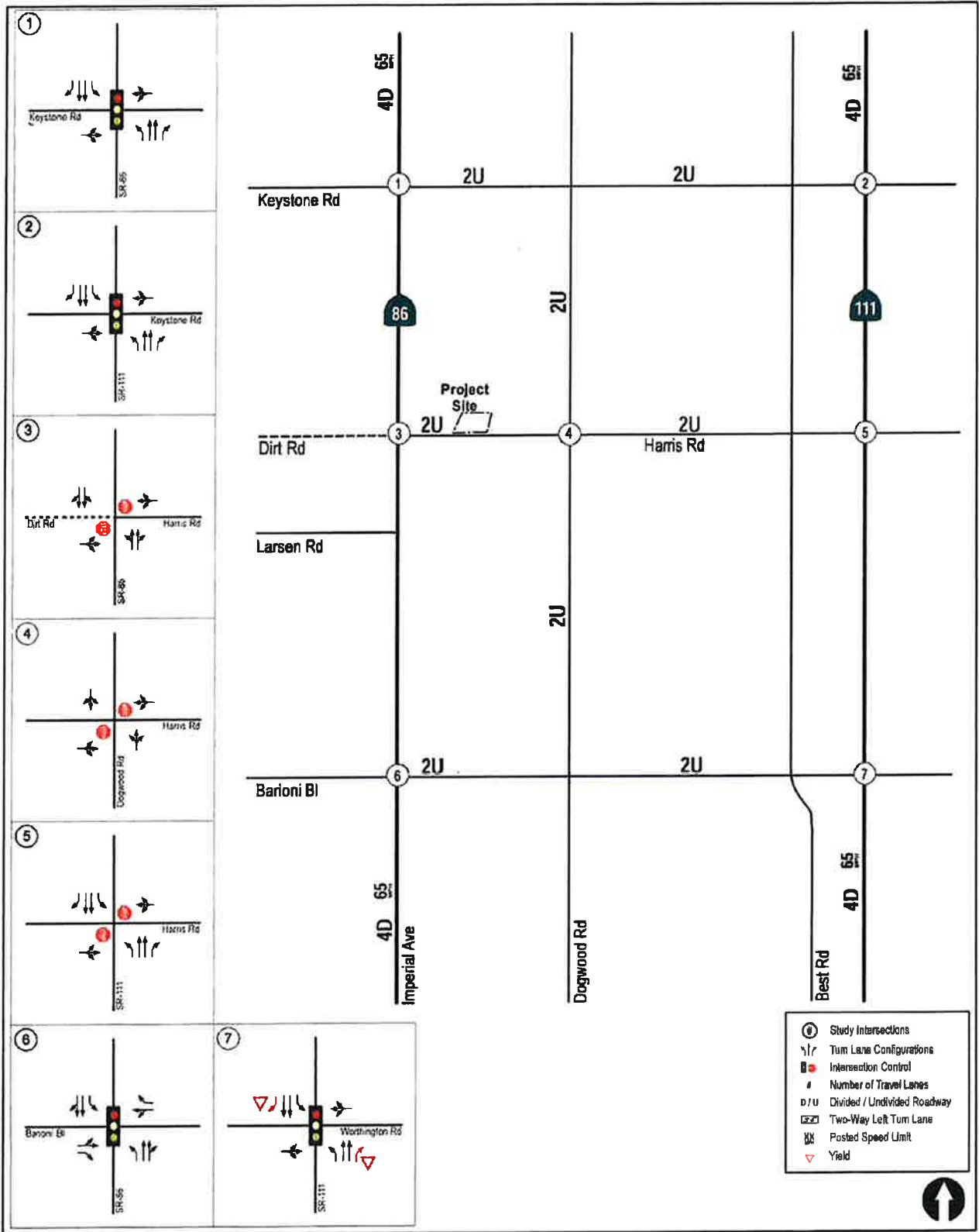

URBAN
 LAW &
 GREENSPAN
 ATTORNEYS
 P.C.

N:12968/Figures
 Date: 09/10/18

Figure 3-1

Existing Conditions Diagram

SIMPLOT FERTILIZER TERMINAL RELOCATION PROJECT

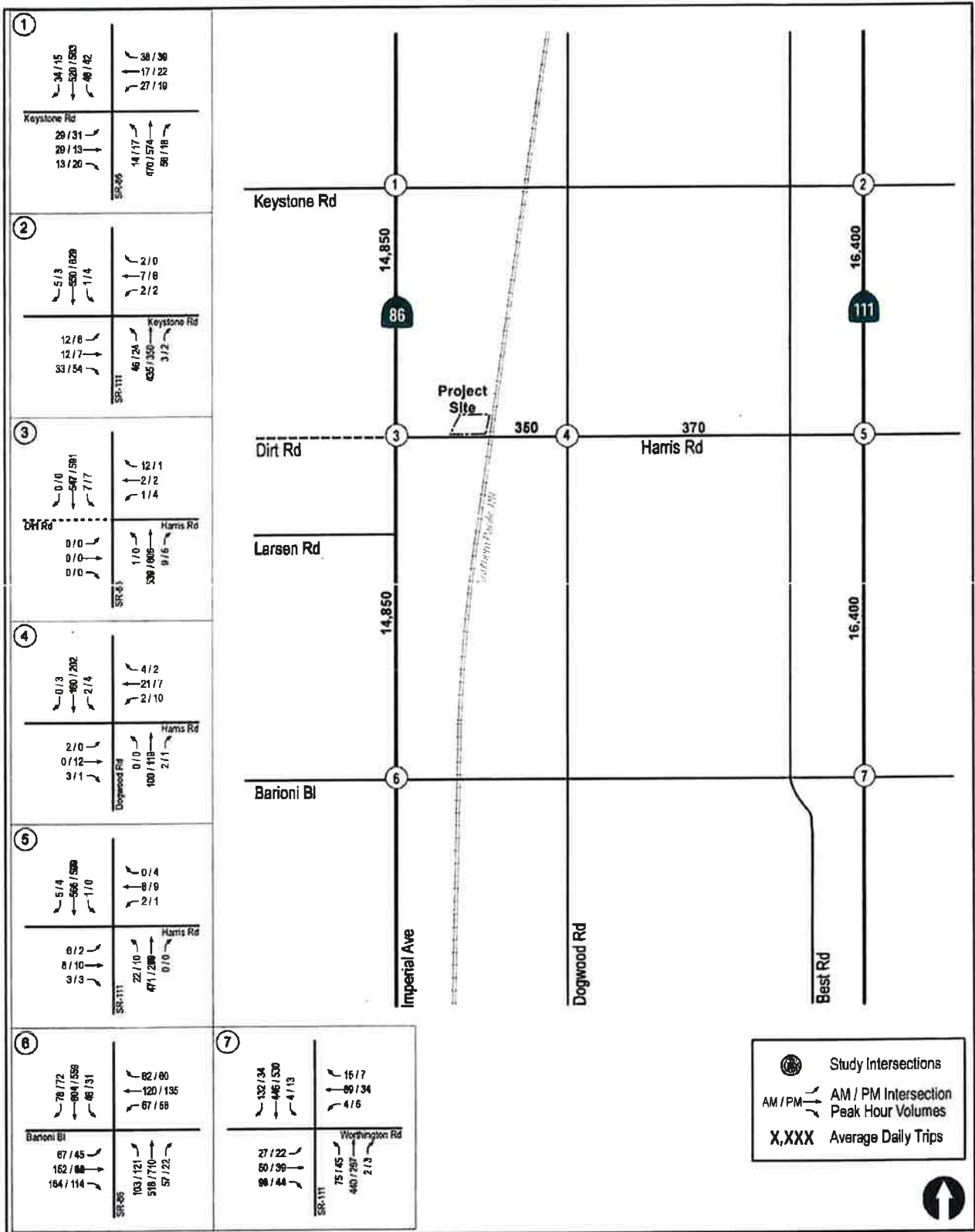

Figure 3-2

Existing Traffic Volumes

SIMPLOT FERTILIZER TERMINAL RELOCATION PROJECT

4.0 ANALYSIS APPROACH AND METHODOLOGY

Based on the anticipated distribution/assignment of project traffic, the intersections included in the study area are listed below.

Intersections

1. SR-86 / Keystone Road
2. SR-111/ Keystone Road
3. SR-86 / Harris Road
4. Dogwood Road / Harris Road
5. SR-111 / Harris Road
6. SR-86 / Barioni Boulevard
7. SR-111 / Worthington Road

Segments

SR-86: Keystone Road to Harris Road;
SR-86: Harris Road to Barioni Boulevard;
SR-111: Keystone Road to Harris Road;
SR-111: Harris Road to Worthington Road;
Harris Road: SR-86 to Dogwood Road; and
Harris Road: Dogwood Road to SR-111.

This report takes into account the effects of the heavy vehicle traffic associated with the project since this type of traffic is more impactful to the local circulation system than passenger cars (See Section 7.1).

The following scenarios are analyzed in this report.

- *Existing*
- *Existing + Project*
- *Existing + Project + Cumulative traffic*

The operations of the project area intersections and segments are characterized using the concept of "Level of Service" (LOS). LOS is the term used to denote the different operating conditions which occur on a given roadway segment under various traffic volume loads. It is a qualitative measure used to describe a quantitative analysis taking into account factors such as roadway geometries, signal phasing, speed, travel delay, freedom to maneuver, and safety. LOS provides an index to the operational qualities of a roadway segment or an intersection. LOS designations range from A through F, with LOS A representing the best operating conditions and LOS F representing the worst operating conditions. LOS designation is reported differently for signalized and unsignalized intersections, as well as for roadway segments.

Table 4-1 summarizes the level of service and delay in seconds per vehicle associated with each level of service.

4.1 Intersections

Signalized intersections were analyzed under weekday 7:00-9:00 AM and 4:00-6:00 PM peak hour conditions. Average vehicle delay was determined utilizing the methodology found in Chapter 18 of the *2016 Highway Capacity Manual (HCM 6th Edition)*, with the assistance of the *Synchro* (version 10) computer software. The delay values (represented in seconds) were qualified with a corresponding intersection LOS. A more detailed explanation of the methodology is attached in *Appendix B. Table 4-1* shows the signalized intersection delay categorized for each level of service (LOS).

Unsignalized intersections were analyzed under weekday 7:00-9:00 AM and 4:00-6:00 PM peak hour conditions. Average vehicle delay and Levels of Service (LOS) were determined based upon the procedures found in Chapters 19 and 20 of the *HCM 6*, with the assistance of the *Synchro* (version 10) computer software. A more detailed explanation of the methodology is attached in *Appendix B. Table 4-1* shows the unsignalized intersection delay categorized for each level of service (LOS).

**TABLE 4-1
INTERSECTION LOS & DELAY RANGES**

LOS	Delay (seconds/vehicle)	
	Signalized Intersections	Unsignalized Intersections
A	≤ 10.0	≤ 10.0
B	10.1 to 20.0	10.1 to 15.0
C	20.1 to 35.0	15.1 to 25.0
D	35.1 to 55.0	25.1 to 35.0
E	55.1 to 80.0	35.1 to 50.0
F	≥ 80.1	≥ 50.1

Source: 2010 Highway Capacity Manual

4.2 Street Segments

Street segments were analyzed based upon the comparison of ADT to the County of Imperial *Roadway Classifications, Levels of Service (LOS) and Average Daily Traffic (ADT)* table (see *Table 4-2* below). Segment analysis is a comparison of ADT volumes and an approximate daily capacity on the subject roadway.

**TABLE 4-2
IMPERIAL COUNTY STANDARD STREET CLASSIFICATION AVERAGE DAILY VEHICLE TRIPS**

Road		Level of Service W/ADT*				
Class	X-Section	A	B	C	D	E
Expressway	128 / 210	30,000	42,000	60,000	70,000	80,000
Prime Arterial	106 / 136	22,200	37,000	44,600	50,000	57,000
Minor Arterial	82 / 102	14,800	24,700	29,600	33,400	37,000
Major Collector (Collector)	64 / 84	13,700	22,800	27,400	30,800	34,200
Minor Collector (Local Collector)	40 / 70	1,900	4,100	7,100	10,900	16,200
Residential Street	40 / 60	*	*	< 1,500	*	*
Residential Cul-de- Sac / Loop Street	40/60	*	*	< 1,500	*	*
Industrial Collector	76 / 96	5,000	10,000	14,000	17,000	20,000
Industrial Local Street	44 / 64	2,500	5,000	7,000	8,500	10,000

* Levels of service are not applied to residential streets since their primary purpose is to serve abutting lots, not carry through traffic. Levels of service normally apply to roads carrying through traffic between major trip generators and attractors.

5.0 SIGNIFICANCE CRITERIA

The County of Imperial does not have published significance criteria. However, the County General Plan does state that the LOS goal for intersections and roadway segments is to operate at LOS C or better. Therefore, if an intersection or segment degrades from LOS C or better to LOS D or worse with the addition of project traffic, the impact is considered significant. If the location operates at LOS D or worse with and without project traffic, the impact is considered significant if the project causes the intersection delta to increase by more than two (2) seconds, or the volume to capacity (V/C) ratio to increase by more than 0.02.

A project is considered to have a significant impact if the new project traffic decreases the operations of surrounding roadways by a defined threshold. The defined thresholds for roadway segments and intersections are defined in *Table 5-1* below. If the project exceeds the thresholds in *Table 5-1*, then the project may be considered to have a significant project impact. A feasible mitigation measure will need to be identified to return the impact within the thresholds (pre-project + allowable increase) or the impact will be considered significant and unmitigated.

**TABLE 5-1
TRAFFIC IMPACT SIGNIFICANT THRESHOLDS**

Level of Service with Project ^a	Allowable Increase Due to Project Impacts ^b					
	Freeways		Roadway Segments		Intersections	Ramp Metering
	V/C	Speed (mph)	V/C	Speed (mph)	Delay (sec.)	Delay (min.)
D, E & F (or ramp meter delays above 15 minutes)	0.01	1	0.02	1	2	2 ^c

Footnotes:

- All level of service measurements are based upon HCM procedures for peak-hour conditions. However, V/C ratios for Roadway Segments may be estimated on an ADT/24-hour traffic volume basis (using Table 4-3 or a similar LOS chart for each jurisdiction). The acceptable LOS for freeways, roadways, and intersections is generally "D" ("C" for undeveloped or not densely developed locations per jurisdiction definitions). For metered freeway ramps, LOS does not apply. However, ramp meter delays above 15 minutes are considered excessive.
- If a proposed project's traffic causes the values shown in the table to be exceeded, the impacts are deemed to be significant. These impact changes may be measured from appropriate computer programs or expanded manual spreadsheets. The project applicant shall then identify feasible mitigations (within the Traffic Impact Study [TIS] report) that will maintain the traffic facility at an acceptable LOS. If the LOS with the proposed project becomes unacceptable (see note a above), or if the project adds a significant amount of peak hour trips to cause any traffic queues to exceed on- or off-ramp storage capacities, the project applicant shall be responsible for mitigating significant impact changes.
- The allowable increase in delay at a ramp meter with more than 15 minutes of delay and freeway LOS E is 2 minutes and at LOS F is 1 minute.

General Notes:

- V/C = Volume to Capacity Ratio
- Speed = Arterial speed measured in miles per hour
- Delay = Average stopped delay per vehicle measured in seconds for intersections, or minutes for ramp meters.
- LOS = Level of Service

6.0 ANALYSIS OF EXISTING CONDITIONS

6.1 Peak Hour Intersection Levels of Service

As seen in *Table 6-1*, all study area intersections are calculated to currently operate at LOS C or better during both the AM and PM peak hours.

Appendix B contains the peak hour intersection analysis worksheets.

**TABLE 6-1
EXISTING INTERSECTION OPERATIONS**

Intersection	Control Type	Peak Hour	Existing	
			Delay ^a	LOS ^b
1. SR 86 / Keystone Road	Signal	AM	8.3	A
		PM	8.1	A
2. SR 111 / Keystone Road	Signal	AM	6.4	A
		PM	6.4	A
3. SR-86 / Harris Road	TWSC ^c	AM	13.1	B
		PM	23.8	C
4. Dogwood Road / Harris Road	TWSC ^c	AM	8.3	A
		PM	8.3	A
5. SR 111 / Harris Road	TWSC ^c	AM	24.5	C
		PM	24.3	C
6. SR-86 / Barioni Boulevard	Signal	AM	29.0	C
		PM	24.4	C
7. SR-111 / Worthington Road	Signal	AM	11.5	B
		PM	9.1	A

Footnotes:

- a. Average delay expressed in seconds per vehicle.
- b. Level of Service.
- c. TWSC – Two-Way Stop Controlled intersection (Minor street turn delay is reported).

SIGNALIZED UNSIGNALIZED

Delay	LOS	Delay	LOS
0.0 ≤ 10.0	A	0.0 ≤ 10.0	A
10.1 to 20.0	B	10.1 to 15.0	B
20.1 to 35.0	C	15.1 to 25.0	C
35.1 to 45.0	D	25.1 to 35.0	D
45.1 to 80.0	E	35.1 to 50.0	E
≥ 80.1	F	≥ 50.1	F

6.2 Daily Street Segment Levels of Service

As seen in *Table 6-2*, all study area segments are calculated to currently operate at LOS B or better on a daily basis.

**TABLE 6-2
EXISTING STREET SEGMENT OPERATIONS**

Street Segment	Capacity (LOS E) ^a	ADT ^b	LOS ^c	V/C ^d
SR-86				
Keystone Road to Harris Road	34,200	14,850	B	0.434
Harris Road to Barioni Boulevard	34,200	14,850	B	0.434
SR-111				
Keystone Road to Harris Road	37,000	16,400	B	0.443
Harris Road to Worthington Road	37,000	16,400	B	0.443
Harris Road				
SR-86 to Dogwood Road	16,200	350	A	0.022
Dogwood Road to SR-111	16,200	370	A	0.023

Footnotes:

- a. Roadway capacity corresponding to Level of Service E from Imperial County Standard Street Classification, Average Daily Vehicle Trips table.
- b. Average Daily Traffic volumes
- c. Level of Service
- d. Volume / Capacity ratio.

7.0 TRIP GENERATION/DISTRIBUTION/ASSIGNMENT

7.1 Trip Generation

The project will generate traffic in terms of employee trips and trucks hauling raw material from the project site to Hotville, Brawley, Imperial, Calipatria, Westmorland and El Centro. A maximum of 20 truck trips are estimated to be generated to ship fertilizer to the recipients. A total of 7 employees are expected to work with a shift of approximately 7 AM to 4 PM.

Passenger Car Equivalence (PCE) is defined as the number of passenger cars that are displaced by a single heavy vehicle of a particular type under the prevailing traffic conditions. Heavy vehicles have a greater traffic impact than passenger cars since:

- They are larger than passenger cars, and therefore, occupy more roadway space; and
- Their performance characteristics are generally inferior to passenger cars, leading to the formation of downstream gaps in the traffic stream (especially on upgrades), which cannot always be effectively filled by normal passing maneuvers.

Much of the project-generated traffic consists of heavy vehicles (trucks). Therefore, a PCE factor of 2.0 per truck was applied to the generated truck trips.

Table 7-1 shows the total project traffic generation based on the information described above. The total project is calculated to generate approximately 108 ADT (with PCE factor) with 15 inbound / 9 outbound trips during the AM peak hour and 9 inbound / 15 outbound trips during the PM peak hour.

TABLE 7-1
TRIP GENERATION

Vehicle Type	Daily Inbound Vehicles	Rate	ADT	PCE Value	ADT With PCE	AM Peak Hour		PM Peak Hour	
						In	Out	In	Out
1 Delivery Trucks	20	2	40	2.0	80	8	8	8	8
2. Staff	7	4	28	1.0	28	7	1	1	7
Total	27	-	68	-	108	15	9	9	15

Footnotes:

Site specific rates based on number of employees and trucks

Assuming all employees enter and leave the site during peak commuter hours and:

* Assumes each truck enters and exits the site (2 trips).

** Assumes each employee leaves the site once during each day.

The Highway Capacity Manual indicates a Passenger Car Equivalence (PCE) of 2.0 for trucks on level terrain.

7.2 Trip Distribution/Assignment

Separate trip distributions were completed for employee and truck trips. The employee distribution was estimated based on a) proximity to state highways, arterials, and freeways; b) the location of local schools, businesses, and housing; and c) study area roadway characteristics. Truck distribution is based on the truck route information provided by the applicant.

It should be noted that outbound trucks would utilize slightly alternative routes than inbound trucks.

Figures 7-1 & 7-2 shows the regional trip distribution for truck trips and employee trips, respectively. The project traffic was assigned to the street system based on these distributions. *Figure 7-3* depicts the project traffic volume assignment for trucks, *Figure 7-4* represents the project traffic volume assignment for employees, *Figure 7-5* represents the total project traffic volumes and *Figure 7-6* shows the existing + total project traffic volumes.

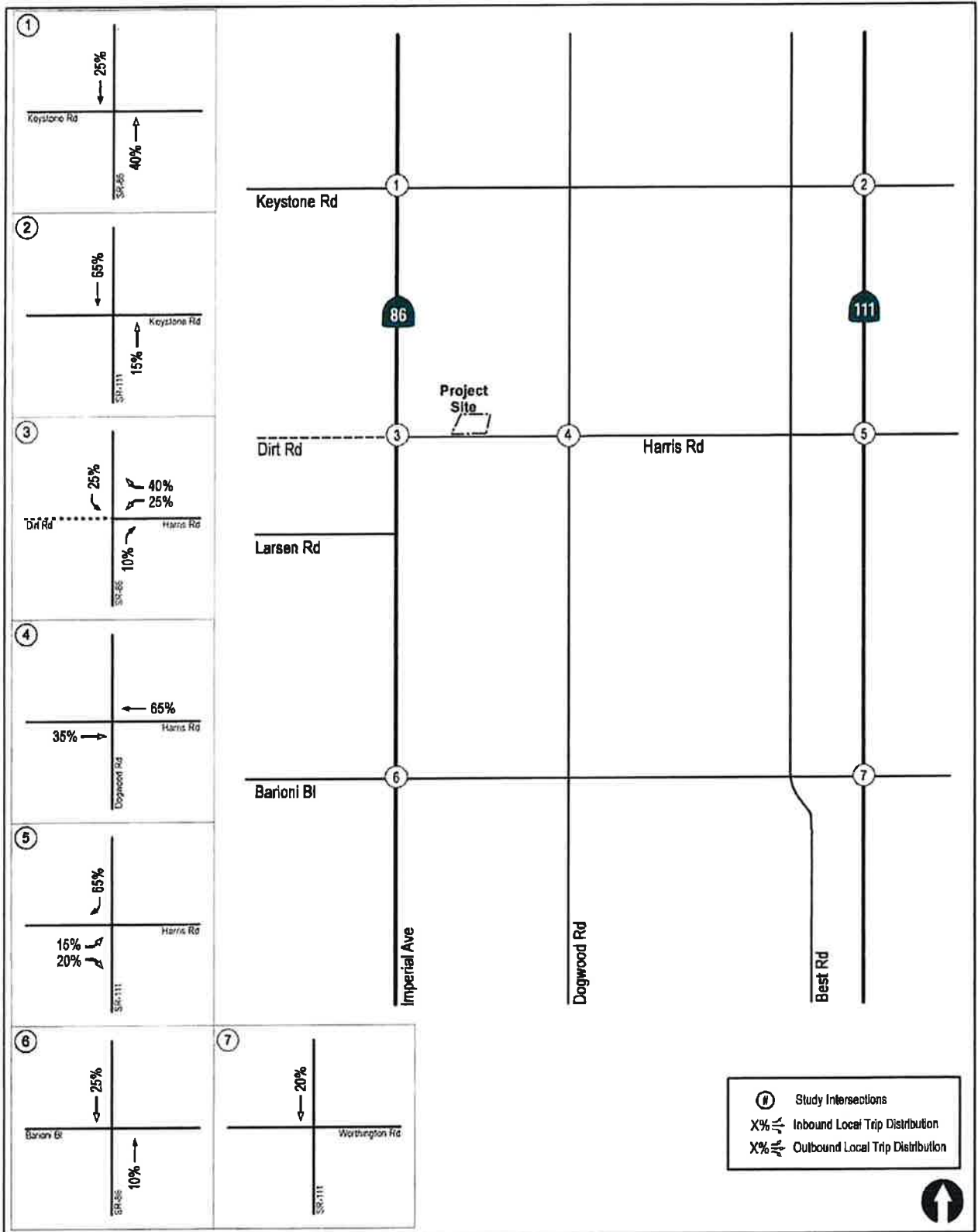

N:\2968\Figures
Date: 09/10/18



Figure 7-1
Project Traffic Distribution
Truck Trips

SIMPLOT FERTILIZER TERMINAL RELOCATION PROJECT

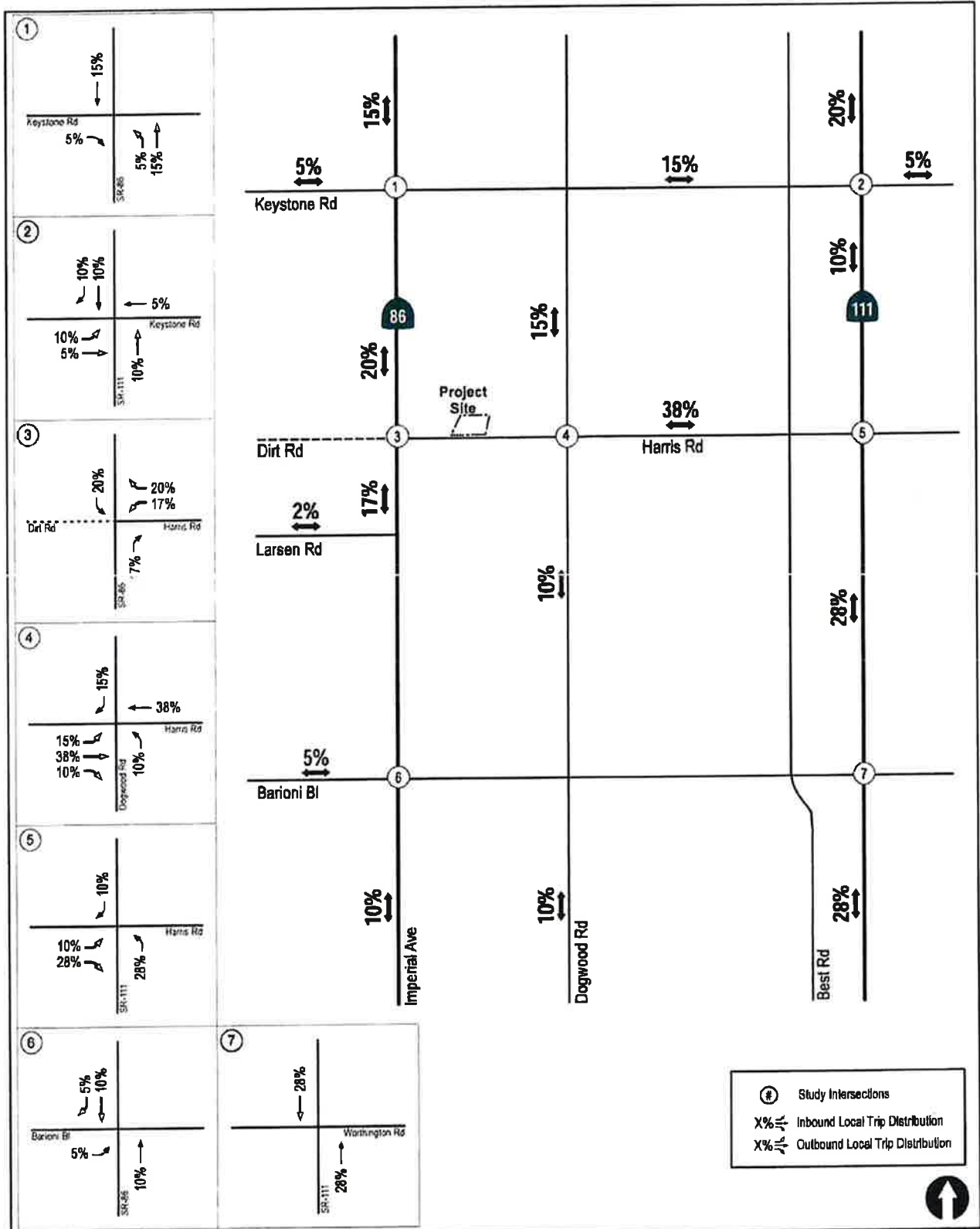

Figure 7-2

**Project Traffic Distribution
Employee Trips**

SIMPLOT FERTILIZER TERMINAL RELOCATION PROJECT



N:12866/Figures
Date: 09/10/18

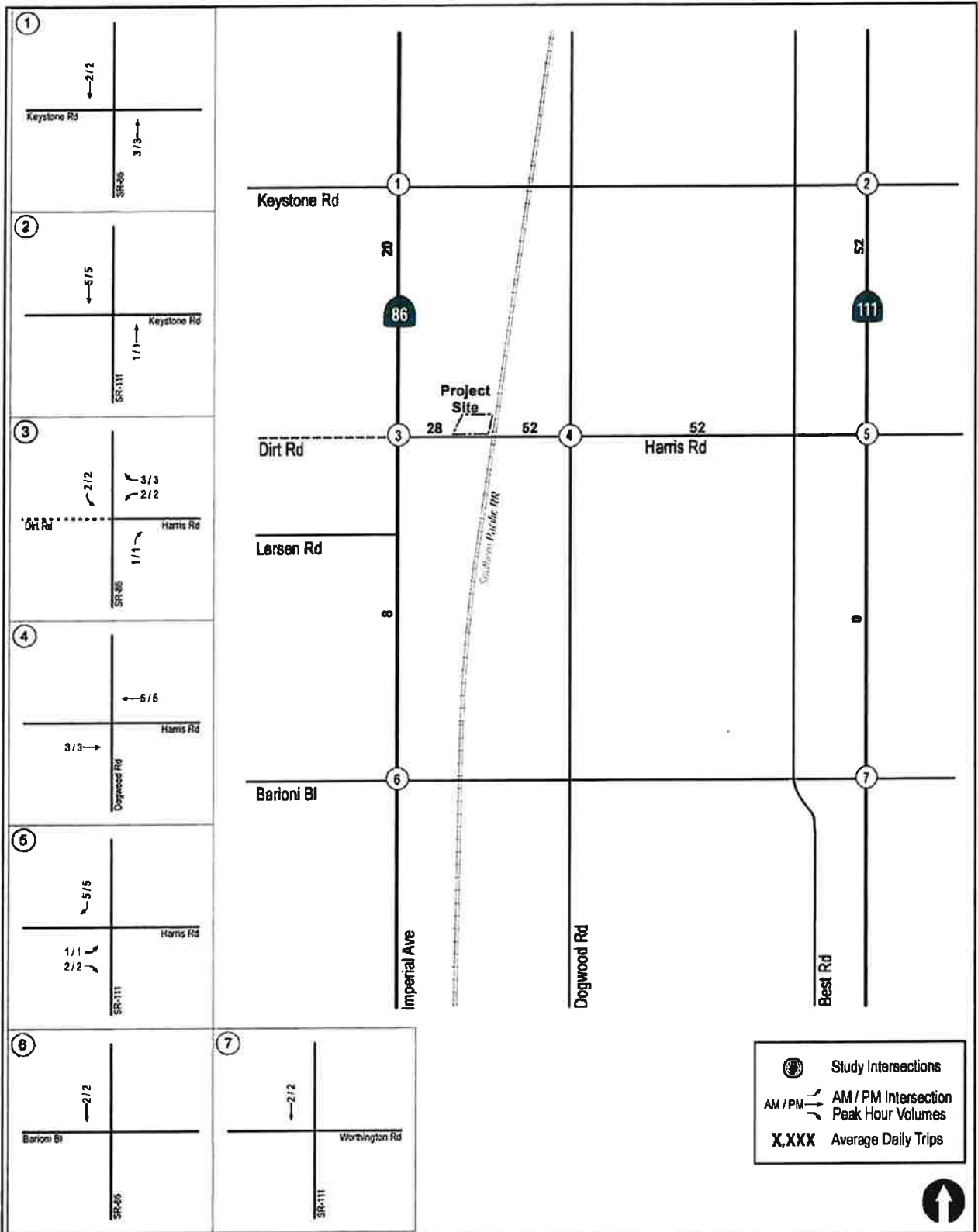

INSLOT
LAW &
GREENSPAN
engineers

N:\2968\Figures
Date: 09/10/18

Figure 7-3
Project Traffic Volumes
Truck Trips

SIMPLOT FERTILIZER TERMINAL RELOCATION PROJECT

EEC ORIGINAL PKG

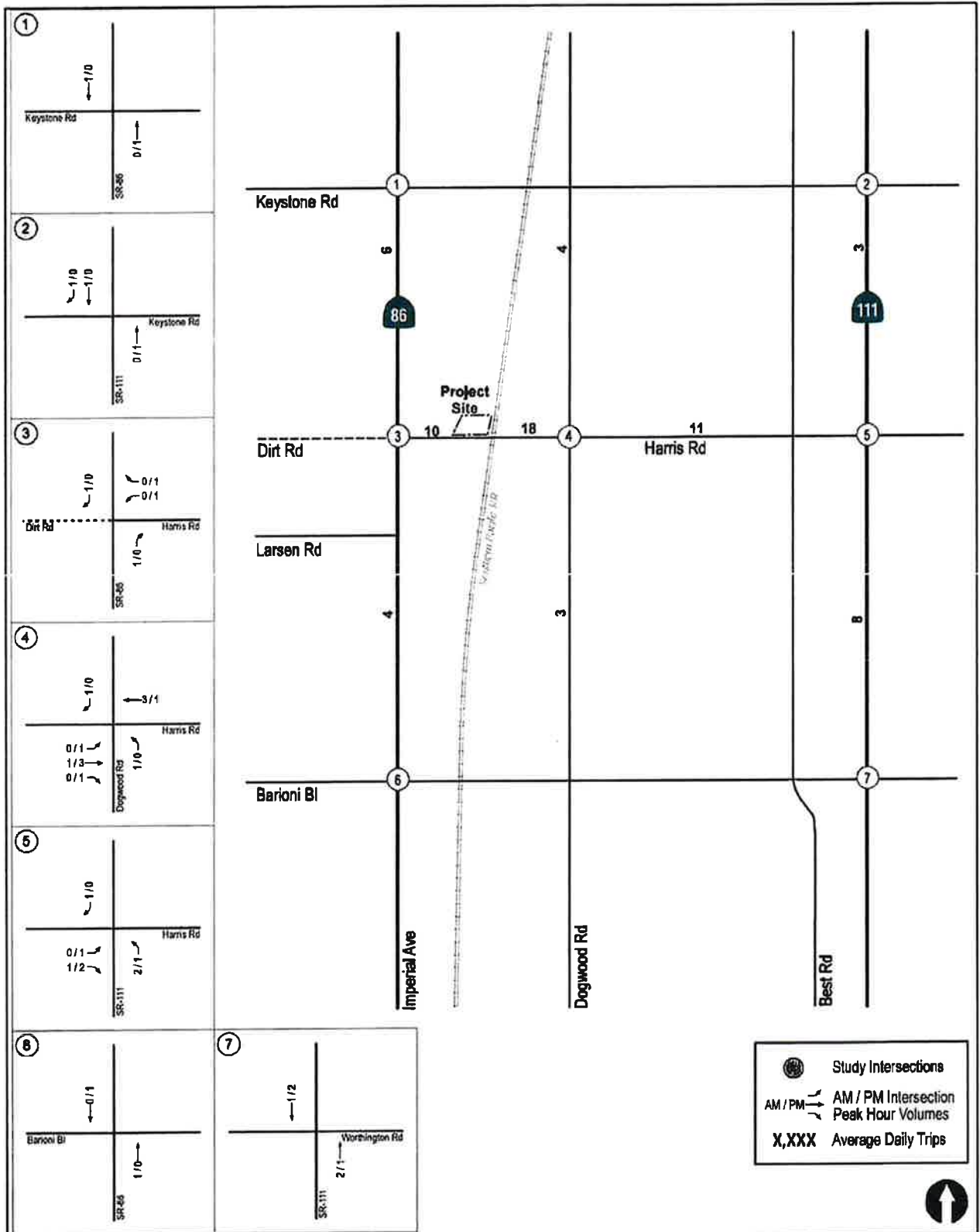

PROJECT
LAWSON
ENGINEERS

N:\2966\Figures
Date: 09/10/18

Figure 7-4
Project Traffic Volumes
Employee Trips

SIMPLON FERTILIZER TERMINAL RELOCATION PROJECT

EEC ORIGINAL PKG

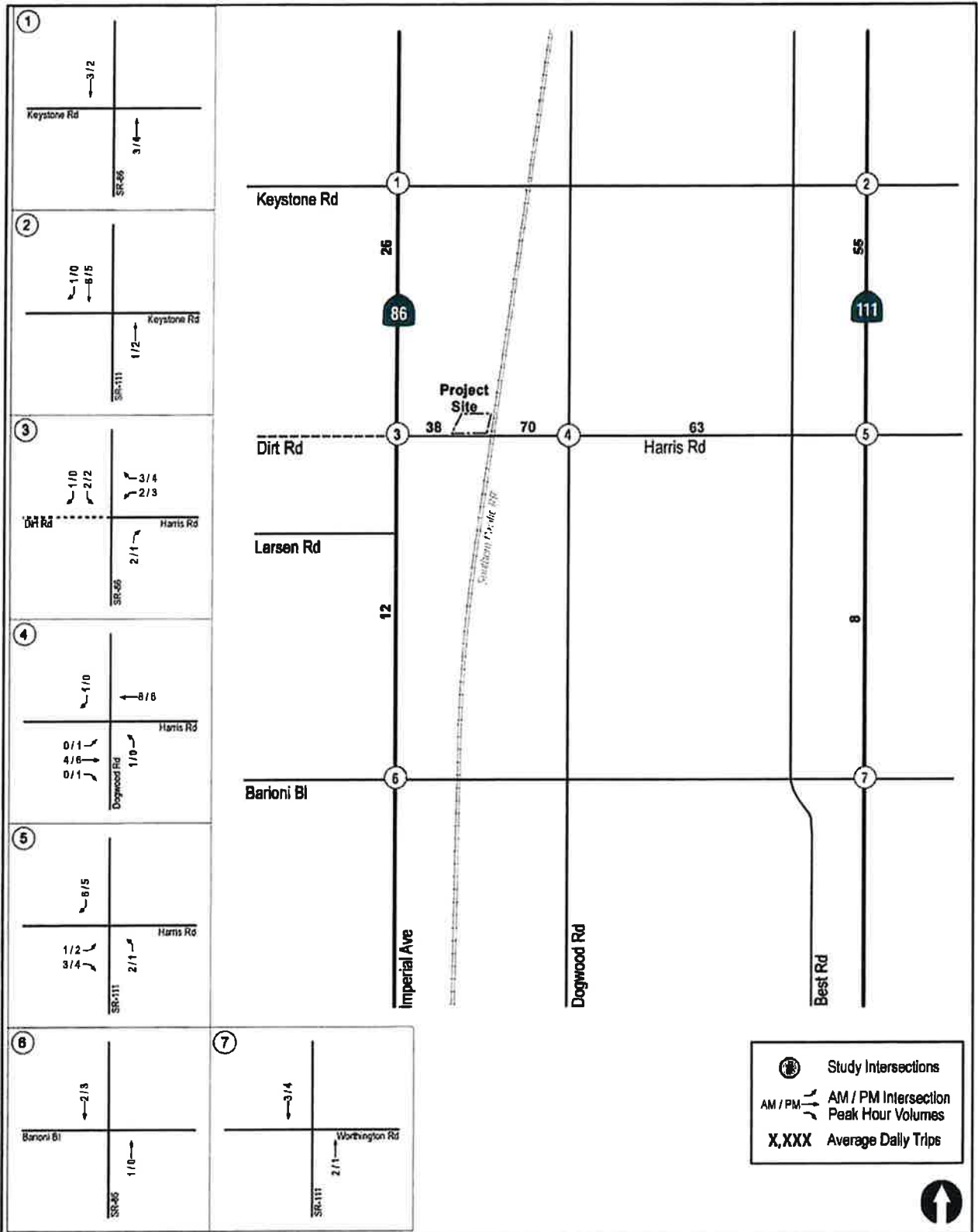

Figure 7-5

Total Project Traffic Volumes

SIMPLOT FERTILIZER TERMINAL RELOCATION PROJECT



N:\2900\Figures
Date: 09/10/18

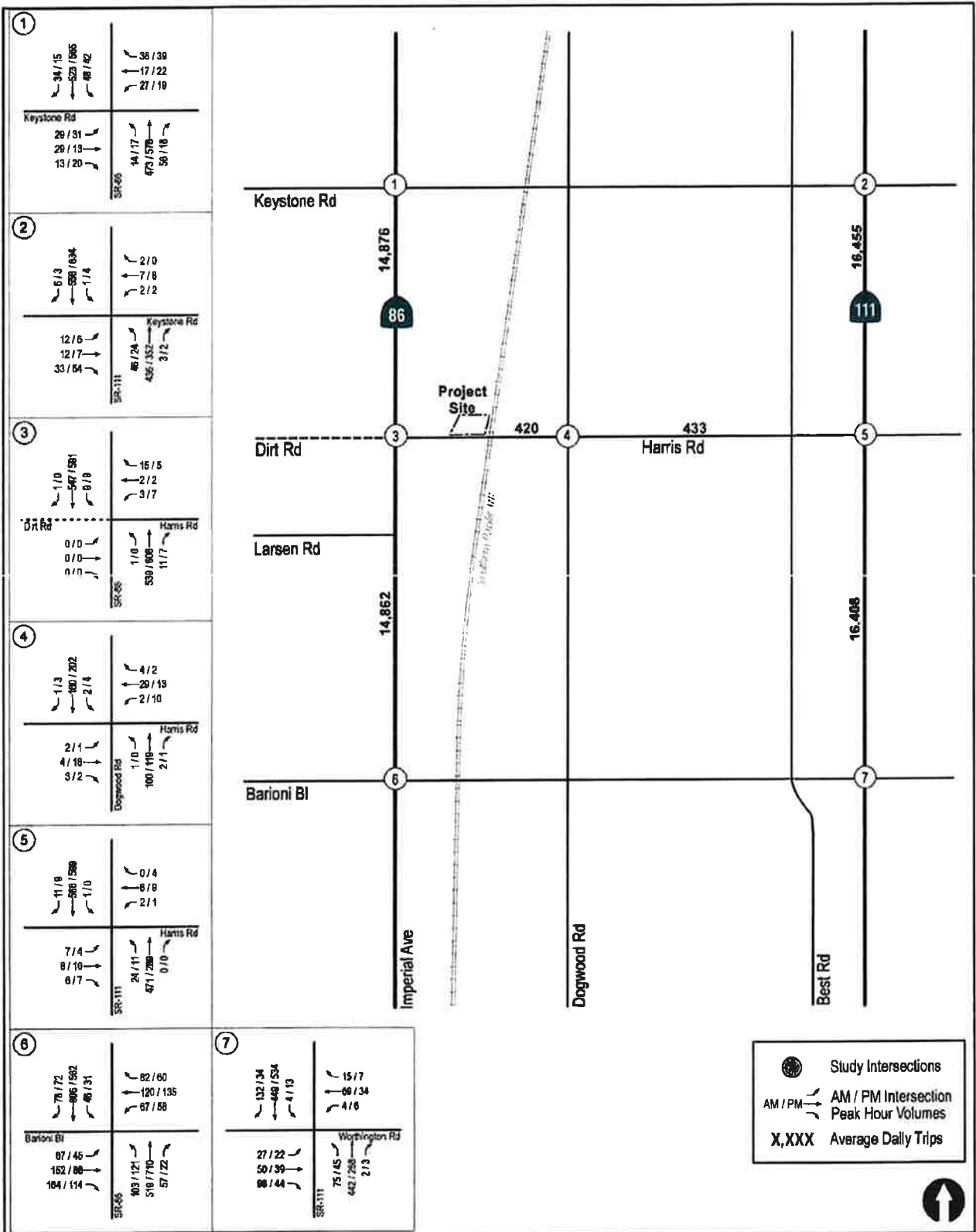

Figure 7-6

Existing + Total Project Traffic Volumes

SIMPLOT FERTILIZER TERMINAL RELOCATION PROJECT

8.0 CUMULATIVE

There are no significant planned projects in the area adjacent to the project site that may add traffic to the surrounding roadways. Therefore to account for any unforeseen increase in traffic, a 20% growth factor was applied to the existing traffic volumes to account for cumulative traffic.

Figure 8-1 depicts the Existing + Total Project + Cumulative.

8.1 Existing + Total Project Analysis

8.1.1 Intersection Operations

Table 8-1 summarizes the intersection operations throughout the project study area with the addition of project traffic. *Table 8-1* shows that all of the intersections in the study area are calculated to operate at LOS C or better during the AM and PM peak hours.

8.1.2 Segment Analysis

Table 8-2 summarizes the street segment operations throughout the project study area with the addition of project traffic. *Table 8-2* shows that all of the street segments in the study area are forecasted to operate at LOS B or better on a daily basis.

8.2 Existing + Total Project + Cumulative Analysis

8.2.1 Intersection Analysis

Table 8-1 summarizes the intersection operations throughout the project study area with the addition of cumulative growth. *Table 8-1* shows that all of the intersections in the study area are calculated to operate at LOS D or better during the AM and PM peak hours.

8.2.2 Segment Analysis

Table 8-2 summarizes the street segment operations throughout the project study area with the addition of cumulative traffic. *Table 8-2* shows that all of the street segments in the study area are forecasted to continue to operate at LOS B or better on a daily basis.

**TABLE 8-1
NEAR-TERM INTERSECTION OPERATIONS**

Intersection	Control Type	Peak Hour	Existing + Total Project		Existing + Total Project + Cumulative		Significant?
			Delay ^a	LOS ^b	Delay	LOS	
1. SR-86 / Keystone Road	Signal	AM	8.3	A	9.0	A	No
		PM	8.1	A	8.3	A	No
2. SR-111 / Keystone Road	Signal	AM	6.4	A	6.8	A	No
		PM	6.4	A	6.4	A	No
3. SR-86 / Harris Road	TWSC ^c	AM	13.7	B	15.6	C	No
		PM	20.6	C	27.7	D	No
4. Dogwood Road / Harris Road	TWSC	AM	8.4	A	8.4	A	No
		PM	8.3	A	8.3	A	No
5. SR-111 / Harris Road	TWSC	AM	24.4	C	24.5	C	No
		PM	24.1	C	24.3	C	No
6. SR-86 / Barioni Boulevard	Signal	AM	29.0	C	39.7	D	No
		PM	24.4	C	28.3	C	No
7. SR-111 / Worthington Road	Signal	AM	11.5	B	12.5	B	No
		PM	9.1	A	9.3	A	No

Footnotes:

- a. Average delay expressed in seconds per vehicle
- b. Level of Service.
- c. TWSC – Two-Way Stop Controlled intersection (Minor street turn delay is reported).

SIGNALIZED

UNSIGNALIZED

Delay	LOS	Delay	LOS
0.0 ≤ 10.0	A	0.0 ≤ 10.0	A
10.1 to 20.0	B	10.1 to 15.0	B
20.1 to 35.0	C	15.1 to 25.0	C
35.1 to 45.0	D	25.1 to 35.0	D
45.1 to 80.0	E	35.1 to 50.0	E
≥ 80.1	F	≥ 50.1	F

**TABLE B-2
NEAR-TERM STREET SEGMENT OPERATIONS**

Street Segment	Existing Capacity (LOS E) ^a	Existing + Project			Existing + Project + Cumulative		
		ADT ^b	LOS ^c	V/C ^d	ADT	LOS	V/C
SR-86							
Keystone Road to Harris Road	34,200	14,876	0.435	B	17,846	B	0.522
Harris Road to Barioni Boulevard	34,200	14,862	0.435	B	17,832	B	0.521
SR-111							
Keystone Road to Harris Road	37,000	16,455	0.445	B	19,735	B	0.533
Harris Road to Worthington Road	37,000	16,408	0.443	B	19,688	B	0.532
Harris Road							
SR-86 to Dogwood Road	16,200	420	0.026	A	490	A	0.030
Dogwood Road to SR-111	16,200	433	0.027	A	507	A	0.031

Footnotes:

- a. Roadway capacity corresponding to Level of Service E from Imperial County Standard Street Classification, Average Daily Vehicle Trips table.
- b. Average Daily Traffic volumes
- c. Level of Service
- d. Volume / Capacity ratio.

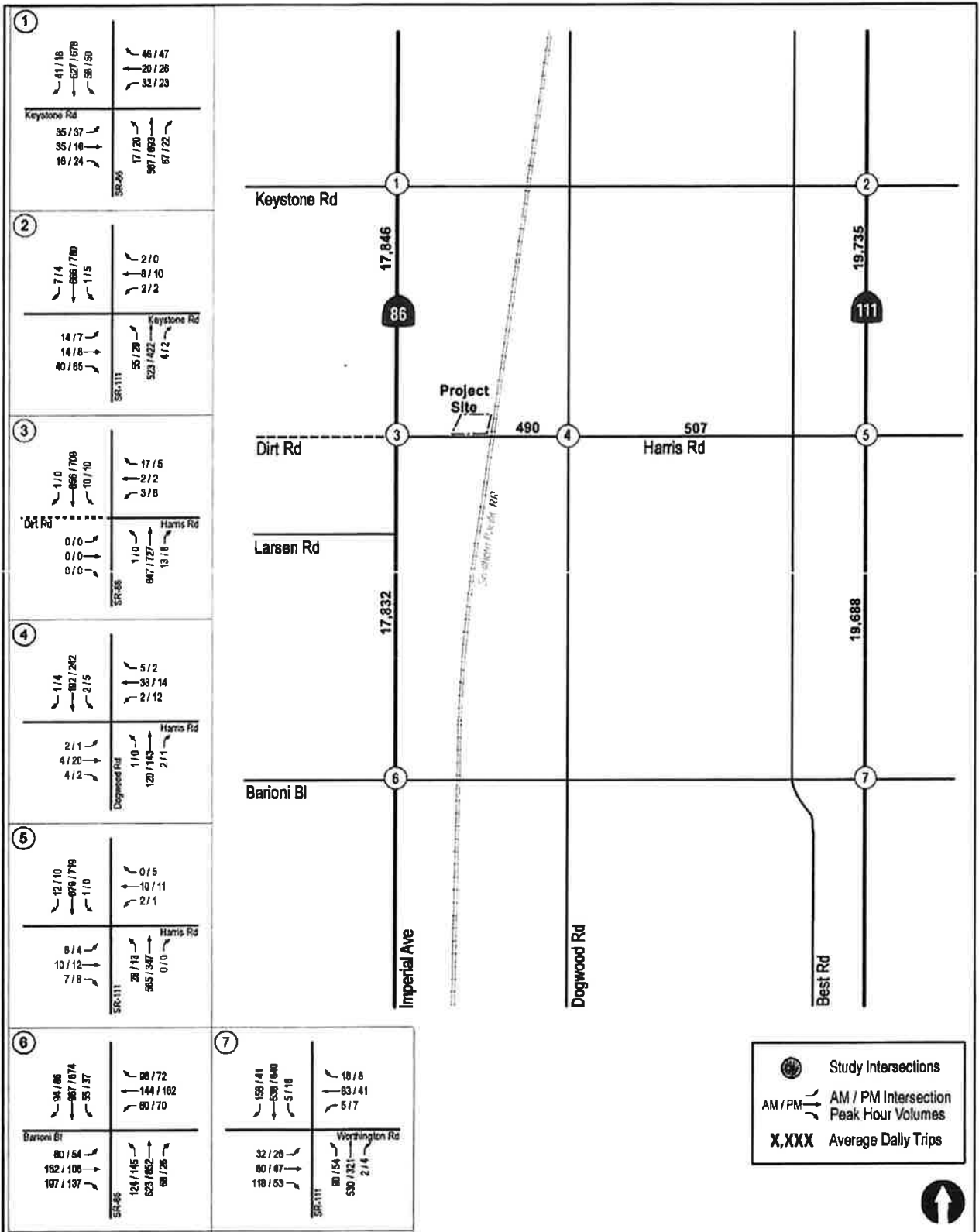

Figure 8-1

Existing + Total Project + Cumulative Traffic Volumes

SIMPLOT FERTILIZER TERMINAL RELOCATION PROJECT

PROJECT
 12345
 678910
 111213

N:\2966\Figures
 Date: 08/10/18

9.0 PROJECT ACCESS

The Project will provide one (1) main access driveway to Harris Road with a secondary “Emergency Access only” gated driveway also provided just west of the main access driveway. Based on the location of the driveway, the relatively low amount of project trips, and the very low traffic volumes along Harris Road, the driveway should perform adequately.

10.0 CONCLUSIONS & RECOMMENDATIONS

The capacity analyses performed for the key roadway segments and study area intersections indicate that *no significant impacts would occur* due to the project. Therefore, mitigation measures are not necessary.

Technical Appendices (dated September 17, 2019)

EEC ORIGINAL PKG

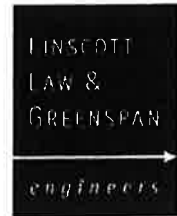

TECHNICAL APPENDICES
SIMPLOT-FERTILIZER TERMINAL
RELOCATION PROJECT
County of Imperial, California
September 17, 2018

LLG Ref. 3-18-2968

**Lincoff, Law &
Greenspan, Engineers**
4542 Ruffner Street
Suite 100
San Diego, CA 92111
858.308.6300 T
858.300.8810 F
www.llgengineers.com

EEC ORIGINAL PKG

APPENDIX A
INTERSECTION AND SEGMENT MANUAL COUNT SHEETS

Intersection Turning Movement - Peak Hour Vehicle Count

COUNT DATA <small>LOW COST TURNING MOVEMENT</small>	Location: #01 Intersection: Imperial Avenue & Keystone Road Date of Count: Thursday August 23, 2018	File Name: ITM-18-120-01 Project: LLG Ref. 3-18-2968 Imperial
---	--	---

AM	Imperial Avenue Southbound			Keystone Road Westbound			Imperial Avenue Northbound			Keystone Road Eastbound			Total
	Left	Thru	Right	Left	Thru	Right	Left	Thru	Right	Left	Thru	Right	
7:00	7	87	7	2	6	7	3	80	9	8	1	2	219
7:15	10	128	5	1	3	3	5	91	12	10	7	7	282
7:30	17	161	14	4	3	7	3	111	18	12	11	0	351
7:45	13	144	8	6	7	9	2	162	19	4	6	3	383
8:00	8	97	7	16	4	19	4	106	7	3	5	3	279
8:15	6	105	4	7	2	8	4	102	5	7	4	4	258
8:30	6	106	7	10	4	5	6	85	2	7	3	4	245
8:45	1	90	3	4	1	4	4	91	3	8	5	3	217
Total	68	908	55	50	30	62	31	828	75	59	42	26	2234
Approach%	6.6	88.1	5.3	35.2	21.1	43.7	3.3	88.7	8.0	46.5	33.1	20.5	
Total%	3.0	40.6	2.5	2.2	1.3	2.8	1.4	37.1	3.4	2.6	1.9	1.2	

AM Intersection Peak Hour: 07:15 to 08:15

Volume	48	520	34	27	17	38	14	470	56	29	29	13	1,295
Approach%	8.0	86.4	5.6	32.9	20.7	46.3	2.6	87.0	10.4	40.8	40.8	18.3	
Total%	3.7	40.2	2.6	2.1	1.3	2.9	1.1	36.3	4.3	2.2	2.2	1.0	
PHF			0.83			0.53			0.74			0.74	

PM	Imperial Avenue Southbound			Keystone Road Westbound			Imperial Avenue Northbound			Keystone Road Eastbound			Total
	Left	Thru	Right	Left	Thru	Right	Left	Thru	Right	Left	Thru	Right	
16:00	11	130	6	20	3	18	6	124	6	6	6	3	339
16:15	10	129	10	2	4	6	3	116	7	5	6	3	301
16:30	11	135	3	7	8	11	2	120	4	11	5	5	322
16:45	13	121	2	4	2	7	3	144	5	9	5	6	321
17:00	7	165	7	3	4	8	5	156	6	5	0	5	361
17:15	11	162	3	5	8	13	7	154	3	6	3	4	369
17:30	5	110	3	5	1	12	2	146	6	10	4	3	307
17:45	5	108	3	3	1	10	4	130	6	10	2	1	281
Total	73	1038	37	49	31	85	32	1090	43	62	31	30	2601
Approach%	6.4	90.4	3.2	29.7	18.8	51.5	2.7	93.6	3.7	50.4	25.2	24.4	
Total%	2.8	39.9	1.4	1.9	1.2	3.3	1.2	41.9	1.7	2.4	1.2	1.2	

PM Intersection Peak Hour: 16:30 to 17:30

Volume	42	563	15	19	22	39	17	574	18	31	13	20	1,373
Approach%	6.8	90.8	2.4	23.8	27.5	48.8	2.8	94.3	3.0	48.4	20.3	31.3	
Total%	3.1	41.0	1.1	1.4	1.6	2.8	1.2	41.8	1.3	2.3	0.9	1.5	
PHF			0.92			0.77			0.91			0.78	

Intersection Turning Movement - Bicycle & Pedestrian Count

URS LOWE'S BUILDINGS 10000 10000	Location: #01	File Name: ITM-18-120-01
	Intersection: Imperial Avenue & Keystone Road	Project: LLG Ref. 3-18-2868
	Date of Count: Thursday August 23, 2018	Imperial

AM	Imperial Avenue Southbound				Keystone Road Westbound				Imperial Avenue Northbound				Keystone Road Eastbound				Totals	
	Ped	B-Left	B-Thru	B-Right	Ped	B-Left	B-Thru	B-Right	Ped	B-Left	B-Thru	B-Right	Ped	B-Left	B-Thru	B-Right	Ped	Bicycle
	7:00	0	0	0	0	0	0	0	0	0	0	0	0	0	0	0	0	0
7:15	0	0	0	0	0	0	0	0	0	0	0	0	0	0	0	0	0	0
7:30	0	0	0	0	0	0	0	0	0	0	0	0	0	0	0	0	0	0
7:45	0	0	0	0	0	0	0	0	0	0	0	0	0	0	0	0	0	0
8:00	0	0	0	0	0	0	0	0	0	0	0	0	0	0	0	0	0	0
8:15	0	0	0	0	0	0	0	0	0	0	0	0	0	0	0	0	0	0
8:30	0	0	0	0	0	0	0	0	0	0	0	0	0	0	0	0	0	0
8:45	0	0	0	0	0	0	0	0	0	0	0	0	0	0	0	0	0	0
Ped Total	0				0				0				0				0	
Bike Total		0	0	0		0	0	0		0	0	0		0	0	0		0

PM	Imperial Avenue Southbound				Keystone Road Westbound				Imperial Avenue Northbound				Keystone Road Eastbound				Totals	
	Ped	B-Left	B-Thru	B-Right	Ped	B-Left	B-Thru	B-Right	Ped	B-Left	B-Thru	B-Right	Ped	B-Left	B-Thru	B-Right	Ped	Bicycle
	16:00	0	0	0	0	0	0	0	0	0	0	0	0	0	0	0	0	0
16:15	0	0	0	0	0	0	0	0	0	0	0	0	0	0	0	0	0	0
16:30	0	0	0	0	0	0	0	0	0	0	0	0	0	0	0	0	0	0
16:45	0	0	0	0	0	0	0	0	0	0	0	0	0	0	0	0	0	0
17:00	0	0	0	0	0	0	0	0	0	0	0	0	0	0	0	0	0	0
17:15	0	0	0	0	0	0	0	0	0	0	0	0	0	0	0	0	0	0
17:30	0	0	0	0	0	0	0	0	0	0	0	0	0	0	0	0	0	0
17:45	0	0	0	0	0	0	0	0	0	0	0	0	0	0	0	0	0	0
Ped Total	0				0				0				0				0	
Bike Total		0	0	0		0	0	0		0	0	0		0	0	0		0

Intersection Turning Movement - Peak Hour Summary



Location: #01	File Name: ITM-18-120-01
Intersection: Imperial Avenue & Keystone Road	Project: LLG Ref. 3-18-2068
Date of Count: Thursday August 23, 2018	Imperial

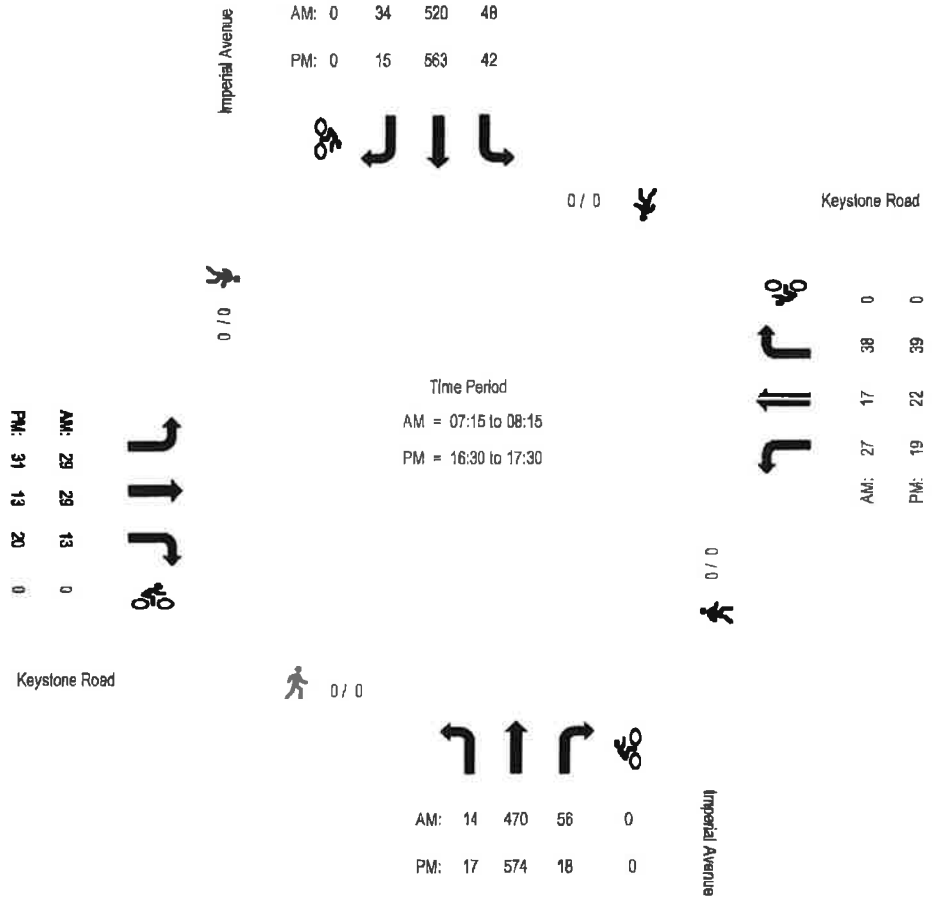

Intersection Turning Movement - Peak Hour Vehicle Count

	Location: #02	File Name: ITM-18-120-02
	Intersection: Imperial Avenue & Harris Road	Project: LLG Ref. 3-18-2988
	Date of Count: Thursday August 23, 2018	Imperial

AM	Imperial Avenue Southbound			Harris Road Westbound			Imperial Avenue Northbound			Harris Road Eastbound			Total
	Left	Thru	Right	Left	Thru	Right	Left	Thru	Right	Left	Thru	Right	
7:00	1	74	0	3	0	8	0	91	1	0	0	0	178
7:15	3	150	0	0	0	1	0	118	1	0	0	0	273
7:30	1	133	0	1	0	5	1	134	2	0	0	0	277
7:45	0	128	0	0	1	4	0	170	4	0	0	0	307
8:00	3	136	0	0	1	2	0	117	2	0	0	0	281
8:15	2	104	0	0	0	2	0	113	1	0	0	1	223
8:30	0	122	0	1	0	2	0	99	1	0	0	1	226
8:45	6	97	0	2	0	3	0	89	1	0	0	0	198
Total	16	944	0	7	2	27	1	931	13	0	0	2	1943
Approach%	1.7	98.3	-	19.4	5.6	75.0	0.1	98.5	1.4	-	-	100.0	
Total%	0.8	48.6	-	0.4	0.1	1.4	0.1	47.9	0.7	-	-	0.1	

AM Intersection Peak Hour: 07:15 to 08:15

Volume	7	547	-	1	2	12	1	539	9	-	-	-	1,118
Approach%	1.3	98.7	-	6.7	13.3	80.0	0.2	98.2	1.6	-	-	-	
Total%	0.6	48.9	-	0.1	0.2	1.1	0.1	48.2	0.8	-	-	-	
PHF			0.91			0.63			0.79			#DIV/0!	

PM	Imperial Avenue Southbound			Harris Road Westbound			Imperial Avenue Northbound			Harris Road Eastbound			Total
	Left	Thru	Right	Left	Thru	Right	Left	Thru	Right	Left	Thru	Right	
16:00	4	135	0	0	0	1	0	135	1	0	0	0	276
16:15	3	142	0	2	0	3	0	95	0	0	0	0	245
16:30	3	145	0	1	0	2	0	107	0	0	0	0	258
16:45	2	136	0	1	0	0	0	161	0	0	0	0	300
17:00	4	165	0	2	1	0	0	138	1	0	0	0	301
17:15	0	178	0	0	1	1	0	162	3	0	0	0	345
17:30	1	122	0	1	0	0	0	145	2	0	0	0	271
17:45	1	113	0	0	0	0	0	130	0	0	0	0	244
Total	18	1126	0	7	2	7	0	1073	7	0	0	0	2240
Approach%	1.6	98.4	-	43.8	12.5	43.8	-	98.4	0.6	-	-	-	
Total%	0.8	50.3	-	0.3	0.1	0.3	-	47.9	0.3	-	-	-	

PM Intersection Peak Hour: 16:45 to 17:45

Volume	7	591	-	4	2	1	-	606	6	-	-	-	1,217
Approach%	1.2	98.8	-	57.1	28.6	14.3	-	98.0	1.0	-	-	-	
Total%	0.6	48.6	-	0.3	0.2	0.1	-	49.8	0.5	-	-	-	
PHF			0.84			0.58			0.93			#DIV/0!	

Intersection Turning Movement - Bicycle & Pedestrian Count

	Location: #02	File Name: ITM-18-120-02
	Intersection: Imperial Avenue & Harris Road	Project: LLG Ref. 3-18-2088
	Date of Count: Thursday August 23, 2018	Imperial

AM	Imperial Avenue Southbound				Harris Road Westbound				Imperial Avenue Northbound				Harris Road Eastbound				Totals	
	Ped	B-Left	B-Thru	B-Right	Ped	B-Left	B-Thru	B-Right	Ped	B-Left	B-Thru	B-Right	Ped	B-Left	B-Thru	B-Right	Ped	Bicycle
7:00	0	0	0	0	1	0	0	0	0	0	0	0	0	0	0	0	1	0
7:15	0	0	0	0	0	0	0	0	0	0	0	0	0	0	0	0	0	0
7:30	0	0	0	0	1	0	0	0	0	0	0	0	0	0	0	0	1	0
7:45	0	0	0	0	0	0	0	0	0	0	0	0	0	0	0	0	0	0
8:00	0	0	0	0	0	0	0	0	0	0	0	0	0	0	0	0	0	0
8:15	0	0	0	0	0	0	0	0	0	0	0	0	0	0	0	0	0	0
8:30	0	0	0	0	0	0	0	0	0	0	0	0	0	0	0	0	0	0
8:45	0	0	0	0	0	0	0	0	0	0	0	0	0	0	0	0	0	0
Ped Total	0				2				0				0				2	
Bike Total		0	0	0		0	0	0		0	0	0		0	0	0		0

PM	Imperial Avenue Southbound				Harris Road Westbound				Imperial Avenue Northbound				Harris Road Eastbound				Totals	
	Ped	B-Left	B-Thru	B-Right	Ped	B-Left	B-Thru	B-Right	Ped	B-Left	B-Thru	B-Right	Ped	B-Left	B-Thru	B-Right	Ped	Bicycle
16:00	0	0	0	0	0	0	0	0	0	0	0	0	0	0	0	0	0	0
16:15	0	0	0	0	0	0	0	0	0	0	0	0	0	0	0	0	0	0
16:30	0	0	0	0	0	0	0	0	0	0	0	0	0	0	0	0	0	0
16:45	0	0	0	0	0	0	0	0	0	0	0	0	0	0	0	0	0	0
17:00	0	0	0	0	0	0	0	0	0	0	0	0	0	0	0	0	0	0
17:15	0	0	0	0	0	0	0	0	0	0	0	0	0	0	0	0	0	0
17:30	0	0	0	0	0	0	0	0	0	0	0	0	0	0	0	0	0	0
17:45	0	0	0	0	0	0	0	0	0	0	0	0	0	0	0	0	0	0
Ped Total	0				0				0				0				0	
Bike Total		0	0	0		0	0	0		0	0	0		0	0	0		0

Intersection Turning Movement - Peak Hour Summary

	Location: #02	File Name: ITM-18-120-02
	Intersection: Imperial Avenue & Harris Road	Project: LLG Ref. 3-18-2968
	Date of Count: Thursday August 23, 2018	Imperial

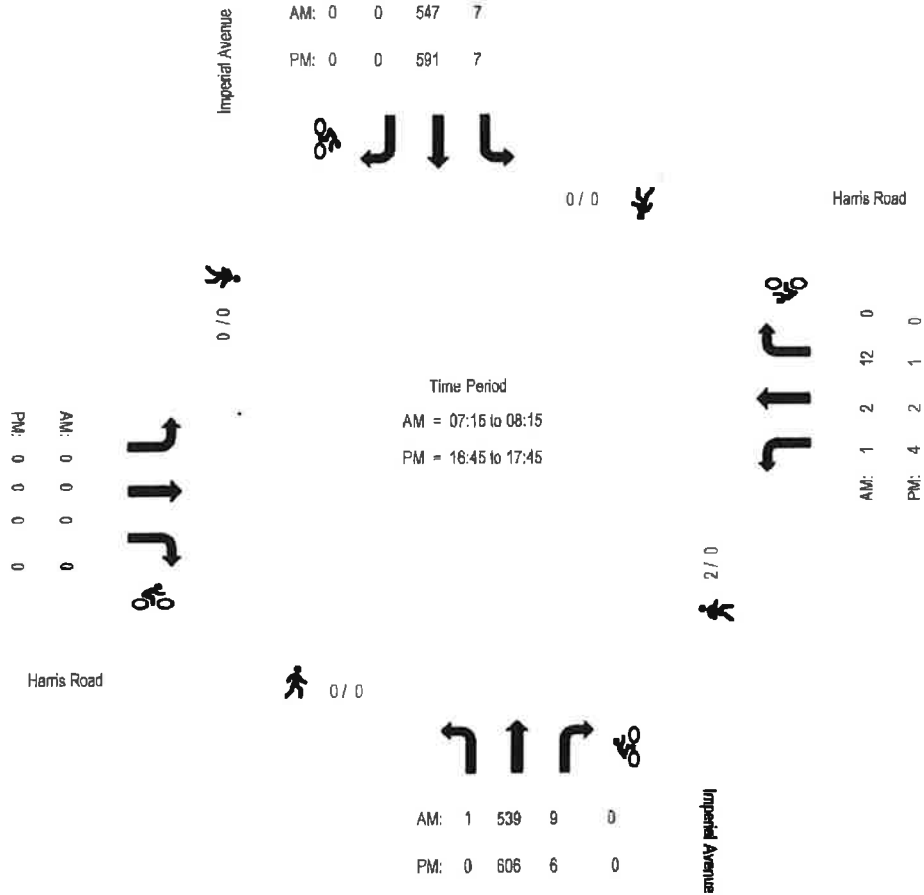

Report Generated by Bearcat Enterprises LLC, DBA "Count Data" | 619-987-5138 | info@yourcountdata.com

Intersection Turning Movement - Peak Hour Vehicle Count

	Location: #03	File Name: ITM-18-120-03
	Intersection: Imperial Avenue & Worthington Road	Project: LLG Ref. 3-18-2968
	Date of Count: Thursday August 23, 2018	Imperial

AM	Imperial Avenue Southbound			Worthington Road Westbound			Imperial Avenue Northbound			Worthington Road Eastbound			Total
	Left	Thru	Right	Left	Thru	Right	Left	Thru	Right	Left	Thru	Right	
7:00	2	110	7	9	13	9	11	82	10	7	15	26	301
7:15	5	160	22	14	21	13	13	107	16	7	33	25	436
7:30	10	227	21	19	34	19	29	153	19	14	36	49	630
7:45	18	262	18	22	37	34	33	122	9	26	47	38	666
8:00	13	155	17	12	28	16	28	136	13	20	36	52	526
8:15	7	151	5	10	14	15	20	94	8	18	14	28	384
8:30	7	138	2	13	20	12	16	90	10	9	19	30	366
8:45	5	125	13	7	19	9	12	93	8	6	16	30	343
Total	67	1328	105	106	186	127	162	877	93	107	216	278	3652
Approach%	4.5	88.5	7.0	25.3	44.4	30.3	14.3	77.5	8.2	17.8	35.9	46.3	
Total%	1.8	36.4	2.9	2.9	5.1	3.5	4.4	24.0	2.5	2.9	5.9	7.6	

AM Intersection Peak Hour: 07:15 to 08:15

Volume	46	804	78	67	120	82	103	518	57	67	152	164	2,258
Approach%	5.0	86.6	8.4	24.9	44.6	30.5	15.2	76.4	8.4	17.5	39.7	42.8	
Total%	2.0	35.6	3.5	3.0	5.3	3.6	4.6	22.9	2.5	3.0	6.7	7.3	
PHF			0.78			0.72			0.84			0.86	

PM	Imperial Avenue Southbound			Worthington Road Westbound			Imperial Avenue Northbound			Worthington Road Eastbound			Total
	Left	Thru	Right	Left	Thru	Right	Left	Thru	Right	Left	Thru	Right	
16:00	6	177	10	11	12	13	19	146	3	7	19	30	453
16:15	6	148	13	13	27	12	22	142	10	6	17	24	440
16:30	9	140	8	16	32	15	19	124	8	14	21	31	437
16:45	10	150	13	17	24	14	22	180	8	20	17	23	498
17:00	5	139	15	10	20	9	26	199	7	12	18	30	490
17:15	12	172	14	16	35	18	33	181	1	10	24	37	553
17:30	7	123	14	20	37	20	27	152	6	11	26	19	462
17:45	7	125	29	12	43	13	35	178	8	12	20	26	510
Total	62	1174	116	115	230	114	203	1302	51	92	162	222	3843
Approach%	4.6	86.8	8.6	25.1	50.1	24.8	13.0	83.7	3.3	19.3	34.0	46.6	
Total%	1.6	30.5	3.0	3.0	6.0	3.0	5.3	33.9	1.3	2.4	4.2	5.8	

PM Intersection Peak Hour: 17:00 to 18:00

Volume	31	559	72	58	135	60	121	710	22	45	88	114	2,015
Approach%	4.7	84.4	10.9	22.9	53.4	23.7	14.2	83.2	2.6	18.2	35.6	46.2	
Total%	1.5	27.7	3.6	2.9	6.7	3.0	6.0	35.2	1.1	2.2	4.4	5.7	
PHF			0.84			0.82			0.92			0.87	

Intersection Turning Movement - Bicycle & Pedestrian Count

	Location:	#03	File Name:	ITM-18-120-03
	Intersection:	Imperial Avenue & Worthington Road	Project:	LLG Ref. 3-18-2988
	Date of Count:	Thursday August 23, 2018		Imperial

AM	Imperial Avenue Southbound				Worthington Road Westbound				Imperial Avenue Northbound				Worthington Road Eastbound				Totals	
	Ped	B-Left	B-Thru	B-Right	Ped	B-Left	B-Thru	B-Right	Ped	B-Left	B-Thru	B-Right	Ped	B-Left	B-Thru	B-Right	Ped	Bicycle
	7:00	1	0	0	0	0	0	0	0	0	0	0	0	0	0	0	0	1
7:15	3	0	0	0	1	0	0	0	0	0	0	0	0	0	0	0	4	0
7:30	2	0	0	0	0	0	0	0	1	0	0	0	0	0	0	0	3	0
7:45	0	0	0	0	0	0	0	0	0	0	0	0	0	0	0	0	0	0
8:00	1	0	0	0	0	0	0	0	2	0	0	0	0	0	0	0	3	0
8:15	0	0	0	0	0	0	0	0	0	0	0	0	0	0	0	0	0	0
8:30	0	0	0	0	0	0	0	0	0	0	0	0	0	0	0	0	0	0
8:45	0	0	0	0	0	0	0	0	0	0	0	0	0	0	0	0	0	0
Ped Total	7				1				3				0				11	
Bike Total		0	0	0		0	0	0		0	0	0		0	0	0		0

PM	Imperial Avenue Southbound				Worthington Road Westbound				Imperial Avenue Northbound				Worthington Road Eastbound				Totals	
	Ped	B-Left	B-Thru	B-Right	Ped	B-Left	B-Thru	B-Right	Ped	B-Left	B-Thru	B-Right	Ped	B-Left	B-Thru	B-Right	Ped	Bicycle
	16:00	0	0	0	0	0	0	0	0	0	0	0	0	0	0	0	0	0
16:15	0	0	0	0	0	0	0	0	0	0	0	0	0	0	0	0	0	0
16:30	1	0	0	0	0	0	0	0	0	0	0	0	0	0	0	0	1	0
16:45	0	0	0	0	0	0	0	0	0	0	0	0	0	0	0	0	0	0
17:00	0	0	0	0	0	0	0	0	0	0	0	0	0	0	0	0	0	0
17:15	0	0	0	0	0	0	0	0	0	0	0	0	0	0	0	0	0	0
17:30	0	0	0	0	0	0	0	0	0	0	0	0	0	0	0	0	0	0
17:45	1	0	0	0	2	0	0	0	0	0	0	0	0	0	0	0	3	0
Ped Total	2				2				0				0				4	
Bike Total		0	0	0		0	0	0		0	0	0		0	0	0		0

Intersection Turning Movement - Peak Hour Summary



Location: #03	File Name: ITM-18-120-03
Intersection: Imperial Avenue & Worthington Road	Project: LLG Ref. 3-18-2088
Date of Count: Thursday August 23, 2018	Imperial

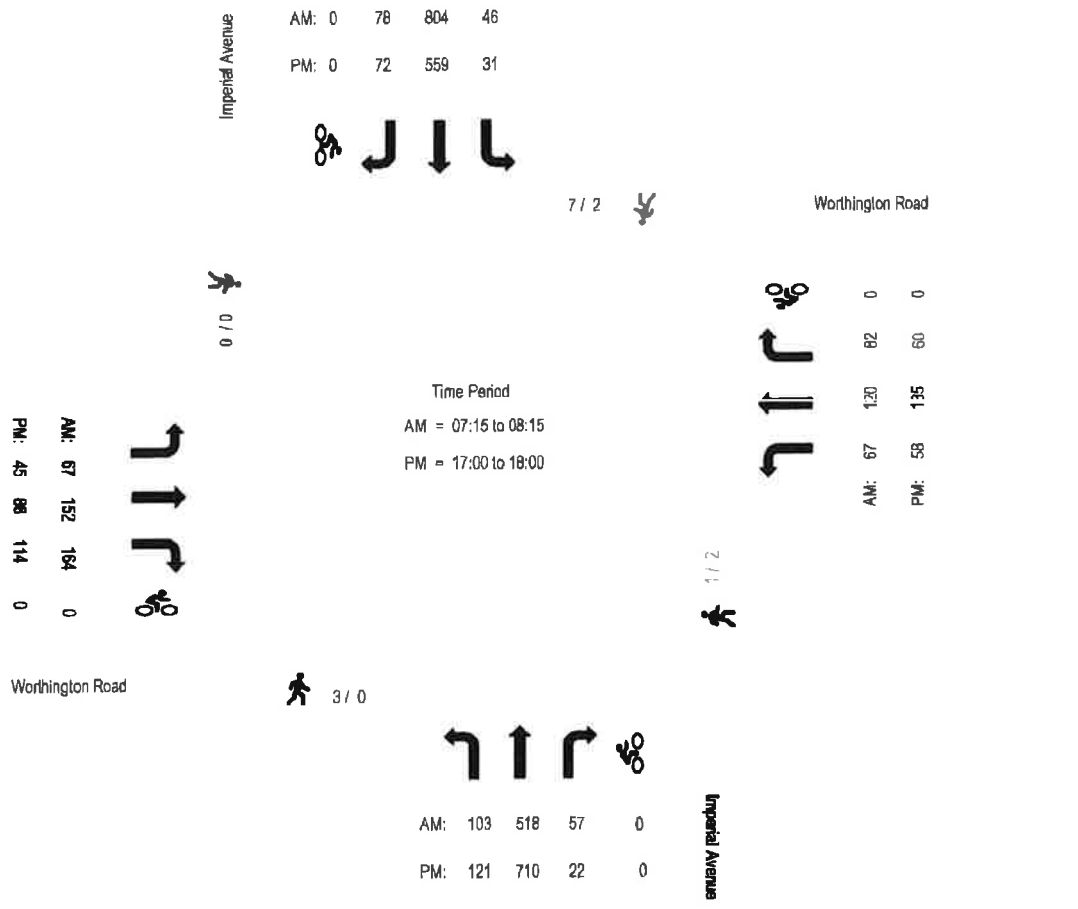

Intersection Turning Movement - Peak Hour Vehicle Count

	Location:	#04	File Name:	ITM-18-120-04
	Intersection:	Dogwood Road & Harris Road	Project:	LLG Ref. 3-18-2968
	Date of Count:	Thursday August 23, 2018		Imperial

AM	Dogwood Road Southbound			Harris Road Westbound			Dogwood Road Northbound			Harris Road Eastbound			Total
	Left	Thru	Right	Left	Thru	Right	Left	Thru	Right	Left	Thru	Right	
7:00	0	27	0	0	7	1	0	15	0	1	0	0	51
7:15	0	28	0	2	3	2	0	23	1	0	0	1	80
7:30	1	45	0	0	6	0	0	29	1	1	0	0	83
7:45	1	60	0	0	5	1	0	33	0	0	0	2	102
8:00	1	26	0	0	3	1	0	17	1	1	0	0	50
8:15	0	23	0	1	2	0	0	14	0	0	0	0	40
8:30	0	27	0	0	2	0	0	13	1	1	0	0	44
8:45	0	22	0	0	5	0	0	15	0	0	0	0	42
Total	3	258	0	3	33	5	0	159	4	4	0	3	472
Approach%	1.1	98.9	-	7.3	80.5	12.2	-	97.5	2.5	57.1	-	42.9	
Total%	0.6	54.7	-	0.8	7.0	1.1	-	33.7	0.8	0.8	-	0.8	

AM Intersection Peak Hour: 07:00 to 08:00

Volume	2	160	-	2	21	4	-	100	2	2	-	3	296
Approach%	1.2	98.8	-	7.4	77.8	14.8	-	98.0	2.0	40.0	-	60.0	
Total%	0.7	54.1	-	0.7	7.1	1.4	-	33.8	0.7	0.7	-	1.0	
PHF			0.66			0.84			0.77			0.63	

PM	Dogwood Road Southbound			Harris Road Westbound			Dogwood Road Northbound			Harris Road Eastbound			Total
	Left	Thru	Right	Left	Thru	Right	Left	Thru	Right	Left	Thru	Right	
16:00	2	36	1	1	2	2	0	33	1	0	5	1	84
16:15	1	38	1	1	1	2	0	43	0	0	2	0	89
16:30	2	60	1	2	3	1	0	18	1	0	4	1	91
16:45	0	34	0	1	0	0	0	20	0	0	2	0	57
17:00	2	55	2	3	1	0	0	37	0	0	5	0	105
17:15	0	53	0	4	3	1	0	46	0	0	1	0	108
17:30	1	48	0	0	0	1	0	33	0	1	3	0	87
17:45	0	30	0	1	1	0	0	21	0	0	0	0	53
Total	8	354	5	13	11	7	0	249	2	1	22	2	674
Approach%	2.2	96.5	1.4	41.9	35.5	22.6	-	99.2	0.8	4.0	88.0	8.0	
Total%	1.2	52.5	0.7	1.9	1.6	1.0	-	36.9	0.3	0.1	3.3	0.3	

PM Intersection Peak Hour: 16:30 to 17:30

Volume	4	202	3	10	7	2	-	119	1	-	12	1	361
Approach%	1.9	96.7	1.4	52.6	36.8	10.5	-	99.2	0.8	-	92.3	7.7	
Total%	1.1	56.0	0.8	2.8	1.9	0.6	-	33.0	0.3	-	3.3	0.3	
PHF			0.83			0.59			0.65			0.65	

Intersection Turning Movement - Bicycle & Pedestrian Count

	Location:	#04	File Name:	ITM-18-120-04
	Intersection:	Dogwood Road & Harris Road	Project:	LLG Ref. 3-18-2068
	Date of Count:	Thursday August 23, 2018		Imperial

AM	Dogwood Road Southbound				Harris Road Westbound				Dogwood Road Northbound				Harris Road Eastbound				Totals	
	Ped	B-Left	B-Thru	B-Right	Ped	B-Left	B-Thru	B-Right	Ped	B-Left	B-Thru	B-Right	Ped	B-Left	B-Thru	B-Right	Ped	Bicycle
7:00	0	0	0	0	0	0	0	0	0	0	0	0	0	0	0	0	0	0
7:15	0	0	0	0	0	0	0	0	0	0	0	0	0	0	0	0	0	0
7:30	0	0	0	0	0	0	0	0	0	0	0	0	0	0	0	0	0	0
7:45	0	0	0	0	0	0	0	0	0	0	0	0	0	0	0	0	0	0
8:00	0	0	0	0	0	0	0	0	0	0	0	0	0	0	0	0	0	0
8:15	0	0	0	0	0	0	0	0	0	0	0	0	0	0	0	0	0	0
8:30	0	0	0	0	0	0	0	0	0	0	0	0	0	0	0	0	0	0
8:45	0	0	0	0	0	0	0	0	0	0	0	0	0	0	0	0	0	0
Ped Total	0				0				0				0				0	
Bike Total		0	0	0		0	0	0		0	0	0		0	0	0	0	0

PM	Dogwood Road Southbound				Harris Road Westbound				Dogwood Road Northbound				Harris Road Eastbound				Totals	
	Ped	B-Left	B-Thru	B-Right	Ped	B-Left	B-Thru	B-Right	Ped	B-Left	B-Thru	B-Right	Ped	B-Left	B-Thru	B-Right	Ped	Bicycle
16:00	0	0	0	0	0	0	0	0	0	0	0	0	0	0	0	0	0	0
16:15	0	0	0	0	0	0	0	0	0	0	0	0	0	0	0	0	0	0
16:30	0	0	0	0	0	0	0	0	0	0	0	0	0	0	0	0	0	0
16:45	0	0	0	0	0	0	0	0	0	0	0	0	0	0	0	0	0	0
17:00	0	0	0	0	0	0	0	0	0	0	0	0	0	0	0	0	0	0
17:15	0	0	0	0	0	0	0	0	0	0	0	0	0	0	0	0	0	0
17:30	0	0	0	0	0	0	0	0	0	0	0	0	0	0	0	0	0	0
17:45	0	0	0	0	0	0	0	0	0	0	0	0	0	0	0	0	0	0
Ped Total	0				0				0				0				0	
Bike Total		0	0	0		0	0	0		0	0	0		0	0	0	0	0

Intersection Turning Movement - Peak Hour Summary



Location: #04	File Name: ITM-18-120-04
Intersection: Dogwood Road & Harris Road	Project: LLG Ref. 3-18-2068
Date of Count: Thursday August 23, 2018	Imperial

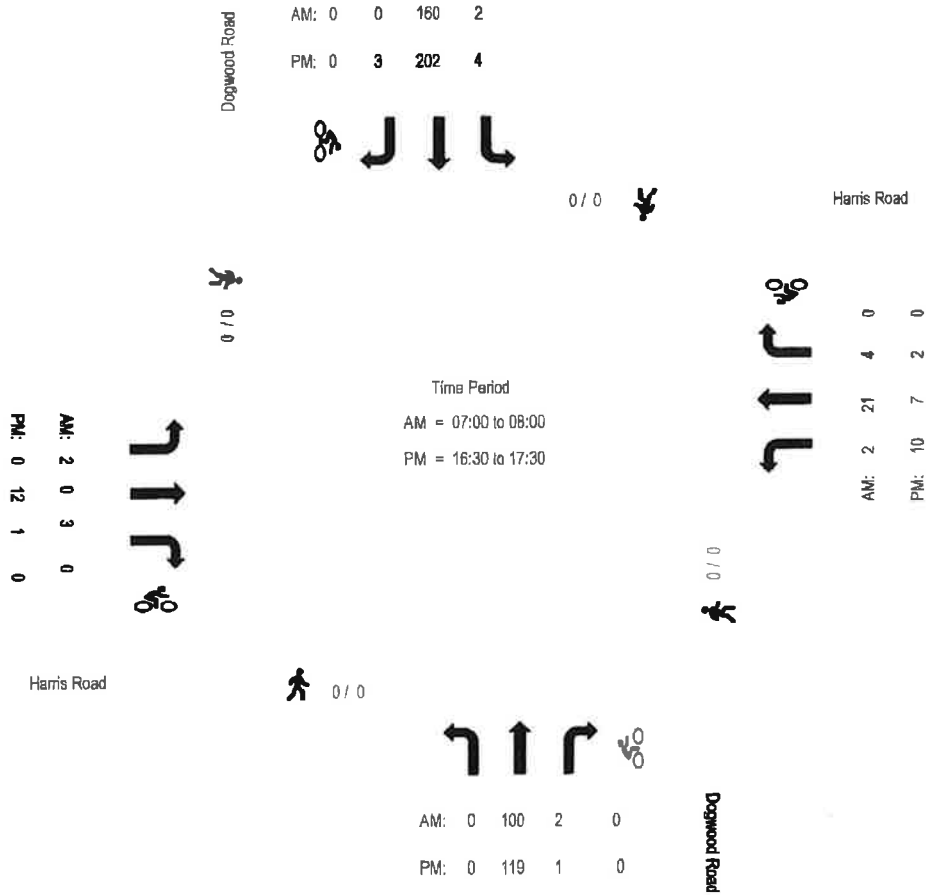

Report Generated by Bearcat Enterprises LLC, DBA "Count Data" | 819-987-5136 | info@yourcountdata.com

Intersection Turning Movement - Peak Hour Vehicle Count

	Location: #05 Intersection: SR-111 & Keystone Road Date of Count: Thursday August 23, 2018	File Name: ITM-18-120-05 Project: LLG Ref. 3-18-2968 Imperial
--	---	---

AM	SR-111 Southbound			Keystone Road Westbound			SR-111 Northbound			Keystone Road Eastbound			Total
	Left	Thru	Right	Left	Thru	Right	Left	Thru	Right	Left	Thru	Right	
7:00	0	101	1	0	4	1	8	97	0	0	1	4	217
7:15	0	128	0	1	3	1	13	123	0	2	4	7	282
7:30	0	171	1	1	2	0	11	113	0	4	2	9	314
7:45	0	154	4	0	1	0	9	109	2	3	3	6	291
8:00	1	97	0	0	1	1	13	90	1	3	3	11	221
8:15	0	98	1	0	3	1	8	82	2	0	2	7	202
8:30	1	83	0	1	6	0	4	87	1	1	0	9	183
8:45	0	100	1	0	2	0	4	72	1	3	5	2	190
Total	2	930	8	3	22	4	70	773	7	16	20	55	1910
Approach%	0.2	98.9	0.9	10.3	75.9	13.8	8.2	90.9	0.8	17.8	22.0	60.4	
Total%	0.1	48.7	0.4	0.2	1.2	0.2	3.7	40.5	0.4	0.8	1.0	2.9	

AM Intersection Peak Hour: 07:15 to 08:15

Volume	1	550	5	2	7	2	46	435	3	12	12	33	1,108
Approach%	0.2	98.9	0.9	18.2	63.6	18.2	9.5	89.9	0.6	21.1	21.1	57.9	
Total%	0.1	49.6	0.5	0.2	0.6	0.2	4.2	39.3	0.3	1.1	1.1	3.0	
PHF			0.81			0.55			0.89			0.84	

PM	SR-111 Southbound			Keystone Road Westbound			SR-111 Northbound			Keystone Road Eastbound			Total
	Left	Thru	Right	Left	Thru	Right	Left	Thru	Right	Left	Thru	Right	
16:00	0	158	0	0	1	0	8	83	1	1	4	18	272
16:15	0	154	1	0	3	0	6	117	1	4	1	15	302
16:30	0	157	0	0	1	0	6	61	1	1	3	11	241
16:45	0	143	0	1	2	0	7	89	0	1	2	18	283
17:00	4	175	2	1	2	0	5	83	0	0	1	10	283
17:15	1	139	2	1	1	0	6	91	0	1	1	10	253
17:30	0	105	3	1	4	0	6	77	0	1	3	14	214
17:45	0	133	1	1	3	0	1	74	1	2	1	5	222
Total	5	1164	9	5	17	0	43	675	4	11	16	101	2050
Approach%	0.4	98.8	0.8	22.7	77.3	-	6.0	93.5	0.6	8.6	12.5	78.9	
Total%	0.2	56.8	0.4	0.2	0.8	-	2.1	32.9	0.2	0.5	0.8	4.9	

PM Intersection Peak Hour: 16:15 to 17:15

Volume	4	629	3	2	8	-	24	350	2	6	7	54	1,089
Approach%	0.6	98.9	0.5	20.0	80.0	-	6.4	93.1	0.5	9.0	10.4	80.6	
Total%	0.4	57.8	0.3	0.2	0.7	-	2.2	32.1	0.2	0.6	0.6	5.0	
PHF			0.88			0.83			0.76			0.80	

Intersection Turning Movement - Bicycle & Pedestrian Count

	Location:	#05	File Name:	ITM-18-120-05
	Intersection:	SR-111 & Keystone Road	Project:	LLG Ref. 3-18-2968
	Date of Count:	Thursday August 23, 2018		Imperial

AM	SR-111 Southbound				Keystone Road Westbound				SR-111 Northbound				Keystone Road Eastbound				Totals	
	Ped	B-Left	B-Thru	B-Right	Ped	B-Left	B-Thru	B-Right	Ped	B-Left	B-Thru	B-Right	Ped	B-Left	B-Thru	B-Right	Ped	Bicycle
	7:00	0	0	0	0	0	0	0	0	0	0	0	0	0	0	0	0	0
7:15	0	0	0	0	0	0	0	0	0	0	0	0	0	0	0	0	0	0
7:30	0	0	0	0	0	0	0	0	0	0	0	0	0	0	0	0	0	0
7:45	0	0	0	0	0	0	0	0	0	0	0	0	0	0	0	0	0	0
8:00	0	0	0	0	0	0	0	0	0	0	0	0	0	0	0	0	0	0
8:15	0	0	0	0	0	0	0	0	0	0	0	0	0	0	0	0	0	0
8:30	0	0	0	0	0	0	0	0	0	0	0	0	0	0	0	0	0	0
8:45	0	0	0	0	0	0	0	0	0	0	0	0	0	0	0	0	0	0
Ped Total	0				0				0				0				0	
Bike Total		0	0	0		0	0	0		0	0	0		0	0	0		0

PM	SR-111 Southbound				Keystone Road Westbound				SR-111 Northbound				Keystone Road Eastbound				Totals	
	Ped	B-Left	B-Thru	B-Right	Ped	B-Left	B-Thru	B-Right	Ped	B-Left	B-Thru	B-Right	Ped	B-Left	B-Thru	B-Right	Ped	Bicycle
	16:00	0	0	0	0	0	0	0	0	0	0	0	0	0	0	0	0	0
16:15	0	0	0	0	0	0	0	0	0	0	0	0	0	0	0	0	0	0
16:30	0	0	0	0	0	0	0	0	0	0	0	0	0	0	0	0	0	0
16:45	0	0	0	0	0	0	0	0	0	0	0	0	0	0	0	0	0	0
17:00	0	0	0	0	0	0	0	0	0	0	0	0	0	0	0	0	0	0
17:15	0	0	0	0	0	0	0	0	0	0	0	0	0	0	0	0	0	0
17:30	0	0	0	0	0	0	0	0	0	0	0	0	0	0	0	0	0	0
17:45	0	0	0	0	0	0	0	0	0	0	0	0	0	0	0	0	0	0
Ped Total	0				0				0				0				0	
Bike Total		0	0	0		0	0	0		0	0	0		0	0	0		0

Intersection Turning Movement - Peak Hour Summary

	Location: #05	File Name: ITM-18-120-05
	Intersection: SR-111 & Keystone Road	Project: LLG Ref. 3-18-2008
	Date of Count: Thursday August 23, 2018	Imperial

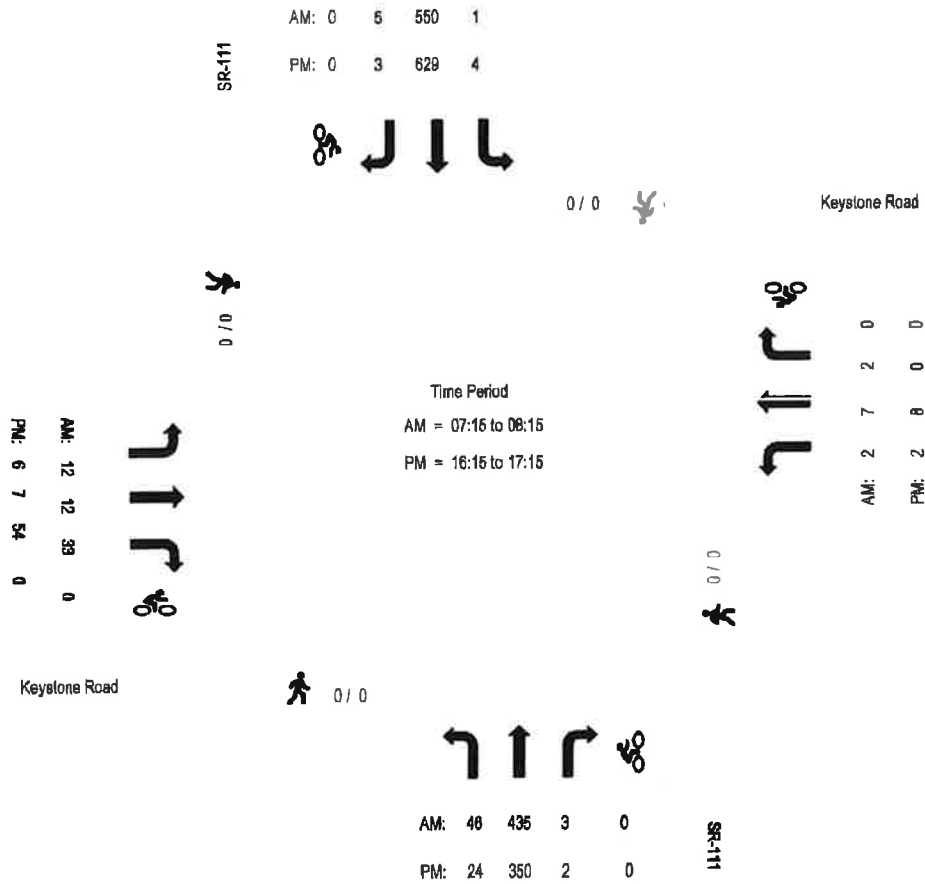

Report Generated by Bearcat Enterprises LLC, DBA "Count Data" | 619-987-5136 | info@yourcountdata.com

Intersection Turning Movement - Peak Hour Vehicle Count

	Location:	#06	File Name:	ITM-18-120-06
	Intersection:	SR-111 & Harris Road	Project:	LLG Ref. 3-18-2068
	Date of Count:	Thursday August 23, 2018		Imperial

AM	SR-111 Southbound			Harris Road Westbound			SR-111 Northbound			Harris Road Eastbound			Total
	Left	Thru	Right	Left	Thru	Right	Left	Thru	Right	Left	Thru	Right	
7:00	0	95	0	1	3	0	3	117	0	2	0	0	221
7:15	1	135	3	0	2	0	5	125	0	2	0	2	275
7:30	0	159	1	2	1	0	3	114	0	3	1	0	284
7:45	0	171	1	0	3	0	6	123	0	1	4	1	310
8:00	0	101	0	0	2	0	8	109	0	0	3	0	223
8:15	0	99	0	0	1	0	2	87	0	0	3	0	192
8:30	0	93	0	0	0	0	2	85	0	2	0	0	182
8:45	0	99	0	0	2	0	1	74	0	0	1	3	180
Total	1	952	5	3	14	0	30	834	0	10	12	6	1867
Approach%	0.1	99.4	0.5	17.6	82.4	-	3.5	98.5	-	35.7	42.9	21.4	
Total%	0.1	51.0	0.3	0.2	0.7	-	1.6	44.7	-	0.5	0.6	0.3	

AM Intersection Peak Hour: 07:15 to 08:15

Volume	1	566	5	2	8	-	22	471	-	6	8	3	1,092
Approach%	0.2	99.0	0.9	20.0	80.0	-	4.5	95.5	-	35.3	47.1	17.6	
Total%	0.1	51.8	0.5	0.2	0.7	-	2.0	43.1	-	0.5	0.7	0.3	
PHF			0.83						0.95			0.71	0.88

PM	SR-111 Southbound			Harris Road Westbound			SR-111 Northbound			Harris Road Eastbound			Total
	Left	Thru	Right	Left	Thru	Right	Left	Thru	Right	Left	Thru	Right	
16:00	0	154	1	0	2	1	1	83	0	3	4	0	249
16:15	0	149	1	0	2	2	2	64	0	0	2	1	223
16:30	0	156	2	1	4	0	4	82	0	2	3	0	234
16:45	0	138	0	0	0	0	1	79	0	0	1	0	219
17:00	0	166	1	0	3	2	3	84	0	0	4	2	255
17:15	0	120	3	0	4	0	2	76	0	0	1	0	208
17:30	0	106	0	0	1	0	0	76	0	0	3	0	186
17:45	0	109	1	0	2	0	2	52	0	0	0	0	166
Total	0	1088	9	1	18	5	15	576	0	5	18	3	1738
Approach%	-	99.2	0.8	4.2	75.0	20.8	2.5	97.5	-	19.2	69.2	11.5	
Total%	-	62.6	0.5	0.1	1.0	0.3	0.9	33.1	-	0.3	1.0	0.2	

PM Intersection Peak Hour: 16:15 to 17:15

Volume	-	599	4	1	9	4	10	289	-	2	10	3	931
Approach%	-	99.3	0.7	7.1	64.3	28.6	3.3	96.7	-	13.3	66.7	20.0	
Total%	-	64.3	0.4	0.1	1.0	0.4	1.1	31.0	-	0.2	1.1	0.3	
PHF			0.95			0.70			0.86			0.63	0.91

Intersection Turning Movement - Bicycle & Pedestrian Count

	Location:	#06	File Name:	ITM-18-120-06
	Intersection:	SR-111 & Harris Road	Project:	LLG Ref. 3-18-2008
	Date of Count:	Thursday August 23, 2018		Imperial

AM	SR-111 Southbound				Harris Road Westbound				SR-111 Northbound				Harris Road Eastbound				Totals	
	Ped	B-Left	B-Thru	B-Right	Ped	B-Left	B-Thru	B-Right	Ped	B-Left	B-Thru	B-Right	Ped	B-Left	B-Thru	B-Right	Ped	Bicycle
7:00	0	0	0	0	0	0	0	0	0	0	0	0	0	0	0	0	0	
7:15	0	0	0	0	0	0	0	0	0	0	0	0	0	0	0	0	0	
7:30	0	0	0	0	0	0	0	0	0	0	0	0	0	0	0	0	0	
7:45	0	0	0	0	0	0	0	0	0	0	0	0	0	0	0	0	0	
8:00	0	0	0	0	0	0	0	0	0	0	0	0	0	0	0	0	0	
8:15	0	0	0	0	0	0	0	0	0	0	0	0	0	0	0	0	0	
8:30	0	0	0	0	0	0	0	0	0	0	0	0	0	0	0	0	0	
8:45	0	0	0	0	0	0	0	0	0	0	0	0	0	0	0	0	0	
Ped Total	0				0				0				0				0	
Bike Total		0	0	0		0	0	0		0	0	0		0	0	0	0	

PM	SR-111 Southbound				Harris Road Westbound				SR-111 Northbound				Harris Road Eastbound				Totals	
	Ped	B-Left	B-Thru	B-Right	Ped	B-Left	B-Thru	B-Right	Ped	B-Left	B-Thru	B-Right	Ped	B-Left	B-Thru	B-Right	Ped	Bicycle
16:00	0	0	0	0	0	0	0	0	0	0	0	0	0	0	0	0	0	
16:15	0	0	0	0	0	0	0	0	0	0	0	0	0	0	0	0	0	
16:30	0	0	0	0	0	0	0	0	0	0	0	0	0	0	0	0	0	
16:45	0	0	0	0	0	0	0	0	0	0	0	0	0	0	0	0	0	
17:00	0	0	0	0	0	0	0	0	0	0	0	0	0	0	0	0	0	
17:15	0	0	0	0	0	0	0	0	0	0	0	0	0	0	0	0	0	
17:30	0	0	0	0	0	0	0	0	0	0	0	0	0	0	0	0	0	
17:45	0	0	0	0	0	0	0	0	0	0	0	0	0	0	0	0	0	
Ped Total	0				0				0				0				0	
Bike Total		0	0	0		0	0	0		0	0	0		0	0	0	0	

Intersection Turning Movement - Peak Hour Summary



Location: #06	File Name: ITM-18-120-06
Intersection: SR-111 & Harris Road	Project: LLG Ref. 3-18-2988
Date of Count: Thursday August 23, 2018	Imperial

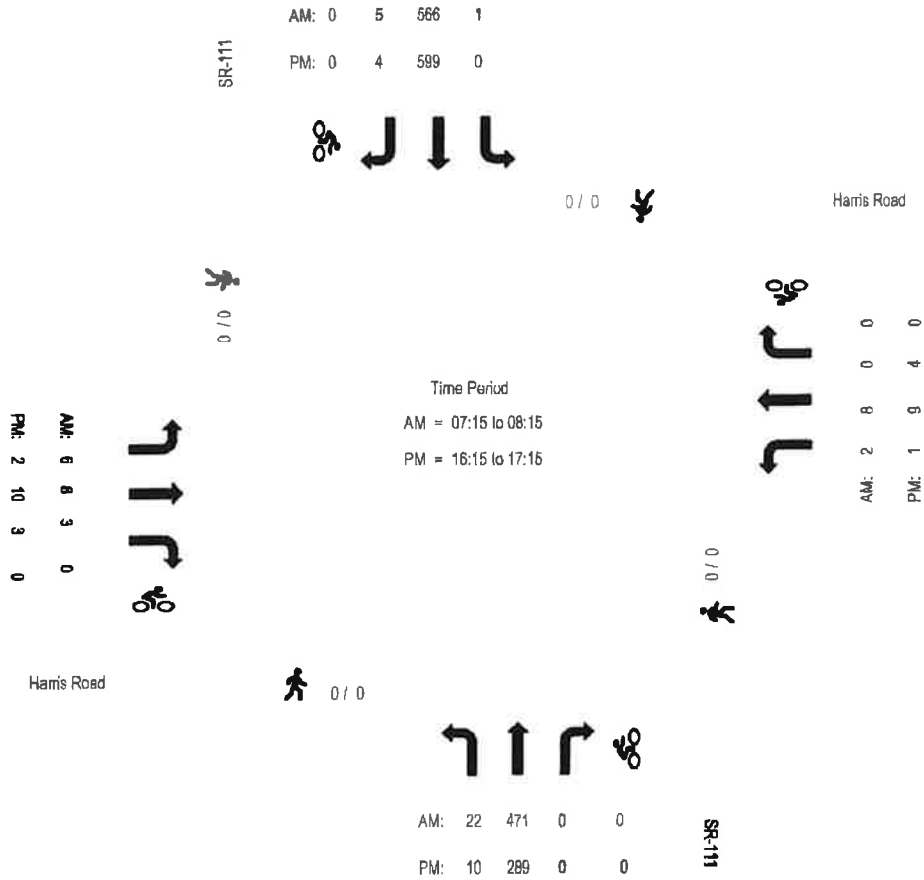

Report Generated by Bearcat Enterprises LLC, DBA "Count Data" | 619-987-5138 | info@yourcountdata.com

Linscott, Law & Greenspan, Engineers

4542 Ruffner Street, Suite 100, San Diego, CA 92111

Average Daily Traffic

Location: Harris Road, between Imperial Avenue and Dogwood Road

Date: Thursday, August 23, 2018		Total Daily Volume: 349																				Description: Total Volume	
0:00	1:00	2:00	3:00	4:00	5:00	6:00	7:00	8:00	9:00	10:00	11:00	12:00	13:00	14:00	15:00	16:00	17:00	18:00	19:00	20:00	21:00	22:00	23:00
0	1	1	1	16	20	28	35	28	23	29	16	20	23	22	19	23	16	13	7	4	1	2	1
0	1	0	0	3	1	3	9	8	5	4	6	2	6	1	5	8	7	3	1	0	0	0	0
0	0	1	0	1	4	2	8	5	9	4	6	6	4	2	6	4	3	1	1	1	1	1	0
0	0	0	0	3	8	13	9	4	5	10	2	7	10	11	6	9	4	7	4	0	0	0	0
0	0	0	1	9	7	10	9	11	4	11	2	5	3	8	2	2	2	2	1	3	0	1	1

Date: Thursday, August 23, 2018		Total Daily Volume: 167																				Description: Eastbound Volume	
0:00	1:00	2:00	3:00	4:00	5:00	6:00	7:00	8:00	9:00	10:00	11:00	12:00	13:00	14:00	15:00	16:00	17:00	18:00	19:00	20:00	21:00	22:00	23:00
0	1	0	1	12	6	8	12	15	10	7	10	14	8	17	12	15	9	3	5	2	0	0	0
0	1	0	0	2	0	1	1	5	1	1	6	2	1	0	2	5	4	1	0	0	0	0	0
0	0	0	0	1	2	1	4	3	5	0	3	4	3	1	5	2	0	0	1	0	0	0	0
0	0	0	0	2	4	5	3	2	3	2	0	3	3	10	4	6	4	2	3	0	0	0	0
0	0	0	1	7	0	1	4	5	1	4	1	5	1	6	1	2	1	0	1	2	0	0	0

Date: Thursday, August 23, 2018		Total Daily Volume: 182																				Description: Westbound Volume	
0:00	1:00	2:00	3:00	4:00	5:00	6:00	7:00	8:00	9:00	10:00	11:00	12:00	13:00	14:00	15:00	16:00	17:00	18:00	19:00	20:00	21:00	22:00	23:00
0	0	1	0	4	14	20	23	13	13	22	6	6	15	5	7	8	7	10	2	2	1	2	1
0	0	0	0	1	1	2	8	3	4	3	0	0	5	1	3	3	3	2	1	0	0	0	0
0	0	1	0	0	2	1	4	2	4	4	3	2	1	1	1	2	3	1	0	1	1	1	0
0	0	0	0	1	4	8	6	2	2	8	2	4	7	1	2	3	0	5	1	0	0	0	0
0	0	0	0	2	7	9	5	6	3	7	1	0	2	2	1	0	1	2	0	1	0	1	1

Report Generated by "Count Data" all rights reserved

Linscott, Law & Greenspan, Engineers

4542 Ruffner Street, Suite 100, San Diego, CA 92111

Average Daily Traffic

Location: Harris Road, between Dogwood Road and Best Road

Date: Thursday, August 23, 2018		Total Daily Volume: 370																			Description: Total Volume		
0:00	1:00	2:00	3:00	4:00	5:00	6:00	7:00	8:00	9:00	10:00	11:00	12:00	13:00	14:00	15:00	16:00	17:00	18:00	19:00	20:00	21:00	22:00	23:00
1	0	2	7	18	27	31	27	22	22	25	18	20	12	33	21	31	24	12	7	4	3	1	2
0	0	1	1	2	1	5	5	7	3	4	3	5	2	5	3	9	10	3	2	0	3	0	0
0	0	1	1	5	6	6	10	5	3	6	6	3	5	7	6	7	7	1	2	2	0	0	0
0	0	0	2	5	10	12	6	4	7	6	5	2	3	13	9	12	5	3	3	0	0	0	1
1	0	0	3	6	10	8	6	6	9	9	4	10	2	8	3	3	2	5	0	2	0	1	1

Date: Thursday, August 23, 2018		Total Daily Volume: 170																			Description: Eastbound Volume		
0:00	1:00	2:00	3:00	4:00	5:00	6:00	7:00	8:00	9:00	10:00	11:00	12:00	13:00	14:00	15:00	16:00	17:00	18:00	19:00	20:00	21:00	22:00	23:00
1	0	1	1	11	11	11	6	14	11	9	9	10	5	20	8	19	10	4	3	3	2	0	1
0	0	1	0	1	0	3	0	5	2	3	2	2	1	2	0	7	5	2	0	0	2	0	0
0	0	0	1	2	1	3	4	4	2	0	4	2	4	3	3	3	1	0	1	1	1	0	0
0	0	0	0	3	6	4	1	2	4	3	1	1	0	10	4	6	4	1	2	0	0	0	1
1	0	0	0	5	4	1	1	3	3	3	2	5	0	5	1	3	0	1	0	2	0	0	0

Date: Thursday, August 23, 2018		Total Daily Volume: 200																			Description: Westbound Volume		
0:00	1:00	2:00	3:00	4:00	5:00	6:00	7:00	8:00	9:00	10:00	11:00	12:00	13:00	14:00	15:00	16:00	17:00	18:00	19:00	20:00	21:00	22:00	23:00
0	0	1	6	7	16	20	21	8	11	16	9	10	7	13	13	12	14	8	4	1	1	1	1
0	0	0	1	1	1	2	5	2	1	1	1	3	1	3	3	2	5	1	2	0	1	0	0
0	0	1	0	3	5	3	6	1	1	6	2	1	1	4	3	4	6	1	1	1	0	0	0
0	0	0	2	2	4	8	5	2	3	3	4	1	3	3	5	6	1	2	1	0	0	0	0
0	0	0	3	1	6	7	5	3	6	6	2	5	2	3	2	0	2	4	0	0	0	1	1

Report Generated by "Count Data" all rights reserved

2016 Traffic Volumes (for ALL vehicles on CA State Highways)

2016 Volumes Home

[Return to Census Program](#) or [Jump to 2011](#) | [2012](#) | [2013](#) | [2014](#) | [2015](#) | [2016](#)

Dist	Rte	CO	Post Mile	Description	Back Peak Hour	Back Peak Month	Back AADT	Ahead Peak Hour	Ahead Peak Month	Ahead AADT
11	086	IMP	9.06	WALL ROAD	2000	23700	22000	1850	22700	21300
11	086	IMP	10.19	IMPERIAL, IMPERIAL AVENUE	1850	22700	21300	1800	22400	20800
11	086	IMP	10.39	IMPERIAL, SECOND STREET	1800	22400	20800	1900	22200	21000
11	086	IMP	10.64	IMPERIAL, FOURTH STREET	1900	22200	21000	1650	20700	19200
11	086	IMP	10.82	IMPERIAL/ BARIONI BLVD	1650	20700	19200	1500	18000	16500
11	086	IMP	11.11	IMPERIAL, TWELFTH STREET	1500	18000	16500	1450	17000	15700
11	086	IMP	11.25	IMPERIAL, FOURTEENTH STREET	1450	17000	15700	1300	15700	14600
11	086	IMP	11.318	IMPERIAL, 15TH STREET	1300	15700	14500	1300	15000	14400
11	086	IMP	11.62	IMPERIAL AVENUE	1300	15000	14400	1250	14300	13500
11	086	IMP	15.32	KEYSTONE ROAD	1250	14300	13500	1350	15800	14000
11	086	IMP	19.19	LEGION ROAD	1400	16100	14300	1900	21200	19100
11	086	IMP	20.08	BRAWLEY, WESTERN AVENUE	1900	21200	19100	1650	18600	16500
11	086	IMP	20.25	BRAWLEY, K STREET	1650	18800	16500	1100	12900	12200
11	086	IMP	20.627	SOUTH JCT. RTE. 78	1100	12900	12200	1500	17500	16800
11	086	IMP	20.99	BRAWLEY, RIO VISTA AVENUE	1500	17500	16800	1750	20400	19500
11	086	IMP	21.25	LAS FLORES DRIVE	1750	20400	19500	980	12100	11500
11	086	IMP R	22.882	KALIN ROAD	980	12100	11500	500	6300	5400
11	086	IMP R	24.057	JCT. RTE. 78	500	6300	5400	830	10100	9500
11	086	IMP R	27.211	WESTMORLAND, B STREET	830	10100	9500	830	9500	8900



2016 Traffic Volumes (for ALL vehicles on CA State Highways)

[2016 Volumes Home](#) | [View](#)

[Return to Census Program](#) or [Jump to 2011](#) | [2012](#) | [2013](#) | [2014](#) | [2015](#) | [2016](#)

Dist	Rte	CO	Post Mile	Description	Back Peak Hour	Back Peak Month	Back AADT	Ahead Peak Hour	Ahead Peak Month	Ahead AADT
11	111	IMP	R 11.299	ATEN RD	1900	23200	20800	1300	17400	16900
11	111	IMP	R 12.874	WORTHINGTON ROAD	1300	17400	16900	1400	16800	14900
11	111	IMP	R 17.385	KEYSTONE ROAD	1400	16800	14900	1350	16800	14600
11	111	IMP	R 22.015	JCT. RTE. 78	1350	16800	14600	840	7700	7200
11	111	IMP	23.538	SHANK ROAD	840	7700	7200	640	6500	6100
11	111	IMP	23.787	DEL RIO RD. RT. Y	640	6500	6100	640	6500	6100
11	111	IMP	24.682	ANDRE RD. F	640	6500	6100	720	6900	5400
11	111	IMP	26.67	RUTHERFORD ROAD	610	7700	6000	900	8600	6800
11	111	IMP	32.01	CALIPATRIA, SOUTH CITY LIMITS	800	7700	6100	790	7600	6000
11	111	IMP	32.513	JCT. RTE 115 EAST	750	7200	5700	710	6700	5400

APPENDIX B
INTERSECTION ANALYSIS WORKSHEETS

HCM 2010 Signalized Intersection Summary
 1: SR-86 & Keystone Road

Ex AM
 09/06/2018

	↖	→	↗	↖	←	↖	↗	↑	↖	↗	↓	↖
Movement	EBL	EBT	EBR	WBL	WBT	WBR	NBL	NBT	NBR	SBL	SBT	SBR
Lane Configurations		↔			↔		↖	↑↑	↗	↖	↑↑	↗
Traffic Volume (veh/h)	29	29	13	27	17	38	14	470	56	48	520	34
Future Volume (veh/h)	29	29	13	27	17	38	14	470	56	48	520	34
Number	7	4	14	3	8	18	5	2	12	1	6	16
Initial Q (Qb), veh	0	0	0	0	0	0	0	0	0	0	0	0
Ped-Bike Adj(A_pbT)	1.00		1.00	1.00		1.00	1.00		1.00	1.00		1.00
Parking Bus, Adj	1.00	1.00	1.00	1.00	1.00	1.00	1.00	1.00	1.00	1.00	1.00	1.00
Adj Sat Flow, veh/h/ln	1900	1863	1900	1900	1863	1900	1863	1863	1863	1863	1863	1863
Adj Flow Rate, veh/h	32	32	14	29	18	41	15	511	61	52	565	37
Adj No. of Lanes	0	1	0	0	1	0	1	2	1	1	2	1
Peak Hour Factor	0.92	0.92	0.92	0.92	0.92	0.92	0.92	0.92	0.92	0.92	0.92	0.92
Percent Heavy Veh, %	2	2	2	2	2	2	2	2	2	2	2	2
Cap, veh/h	141	70	26	124	38	66	33	2209	988	88	2319	1037
Arrive On Green	0.09	0.09	0.09	0.09	0.09	0.09	0.02	0.62	0.62	0.05	0.66	0.66
Sat Flow, veh/h	584	817	307	448	440	775	1774	3539	1583	1774	3539	1583
Grp Volume(v), veh/h	78	0	0	88	0	0	15	511	61	52	565	37
Grp Sat Flow(s),veh/h/ln	1708	0	0	1663	0	0	1774	1770	1583	1774	1770	1583
Q Serve(g_s), s	0.0	0.0	0.0	0.4	0.0	0.0	0.5	3.6	0.8	1.6	3.7	0.5
Cycle Q Clear(g_c), s	2.3	0.0	0.0	2.7	0.0	0.0	0.5	3.6	0.8	1.6	3.7	0.5
Prop In Lane	0.41		0.18	0.33		0.47	1.00		1.00	1.00		1.00
Lane Grp Cap(c), veh/h	237	0	0	228	0	0	33	2209	988	88	2319	1037
V/C Ratio(X)	0.33	0.00	0.00	0.39	0.00	0.00	0.46	0.23	0.06	0.59	0.24	0.04
Avail Cap(c_a), veh/h	1106	0	0	1087	0	0	158	2209	988	158	2319	1037
HCM Platoon Ratio	1.00	1.00	1.00	1.00	1.00	1.00	1.00	1.00	1.00	1.00	1.00	1.00
Upstream Filter(I)	1.00	0.00	0.00	1.00	0.00	0.00	1.00	1.00	1.00	1.00	1.00	1.00
Uniform Delay (d), s/veh	24.5	0.0	0.0	24.7	0.0	0.0	27.2	4.6	4.1	26.1	4.0	3.4
Incr Delay (d2), s/veh	0.8	0.0	0.0	1.1	0.0	0.0	9.5	0.2	0.1	6.2	0.2	0.1
Initial Q Delay(d3),s/veh	0.0	0.0	0.0	0.0	0.0	0.0	0.0	0.0	0.0	0.0	0.0	0.0
%ile BackOfQ(50%),veh/ln	1.2	0.0	0.0	1.4	0.0	0.0	0.3	1.8	0.4	0.9	1.8	0.2
LnGrp Delay(d),s/veh	25.3	0.0	0.0	25.7	0.0	0.0	36.7	4.9	4.2	32.3	4.2	3.5
LnGrp LOS	C			C			D	A	A	C	A	A
Approach Vol, veh/h		78			88			587			654	
Approach Delay, s/veh		25.3			25.7			5.6			6.4	
Approach LOS		C			C			A			A	
Timer	1	2	3	4	5	6	7	8				
Assigned Phs	1	2		4	5	6		8				
Phs Duration (G+Y+Rc), s	7.3	39.5		9.3	5.5	41.2		9.3				
Change Period (Y+Rc), s	4.5	4.5		4.5	4.5	4.5		4.5				
Max Green Setting (Gmax), s	5.0	35.0		36.0	5.0	35.0		36.0				
Max Q Clear Time (g_c+I1), s	3.6	5.6		4.3	2.5	5.7		4.7				
Green Ext Time (p_c), s	0.0	3.9		0.4	0.0	4.3		0.5				
Intersection Summary												
HCM 2010 Ctrl Delay				8.3								
HCM 2010 LOS				A								

HCM 2010 Signalized Intersection Summary
 2: SR-111 & Keystone Road

Ex AM
 09/06/2018

Movement	EBL	EBT	EBR	WBL	WBT	WBR	NBL	NBT	NBR	SBL	SBT	SBR
Lane Configurations		⇄			⇄		↖	↗	↖	↗	↗	↖
Traffic Volume (veh/h)	12	12	33	2	7	2	48	435	3	1	550	5
Future Volume (veh/h)	12	12	33	2	7	2	48	435	3	1	550	5
Number	7	4	14	3	8	18	5	2	12	1	6	16
Initial Q (Qb), veh	0	0	0	0	0	0	0	0	0	0	0	0
Ped-Bike Adj(A_pbT)	1.00		1.00	1.00		1.00	1.00		1.00	1.00		1.00
Parking Bus, Adj	1.00	1.00	1.00	1.00	1.00	1.00	1.00	1.00	1.00	1.00	1.00	1.00
Adj Sat Flow, veh/h/in	1900	1863	1900	1900	1863	1900	1863	1863	1863	1863	1863	1863
Adj Flow Rate, veh/h	13	13	36	2	8	2	50	473	3	1	598	5
Adj No. of Lanes	0	1	0	0	1	0	1	2	1	1	2	1
Peak Hour Factor	0.92	0.92	0.92	0.92	0.92	0.92	0.92	0.92	0.92	0.92	0.92	0.92
Percent Heavy Veh, %	2	2	2	2	2	2	2	2	2	2	2	2
Cap, veh/h	114	25	62	105	84	20	91	2266	1014	4	2090	935
Arrive On Green	0.07	0.07	0.07	0.07	0.07	0.07	0.05	0.64	0.64	0.00	0.59	0.59
Sat Flow, veh/h	298	372	929	216	1264	296	1774	3539	1583	1774	3539	1583
Grp Volume(v), veh/h	62	0	0	12	0	0	50	473	3	1	598	5
Grp Sat Flow(s),veh/h/in1800	0	0	1775	0	0	1774	1770	1583	1774	1770	1770	1583
Q Serve(g_s), s	1.4	0.0	0.0	0.0	0.0	0.0	1.3	2.6	0.0	0.0	3.9	0.1
Cycle Q Clear(g_c), s	1.7	0.0	0.0	0.3	0.0	0.0	1.3	2.6	0.0	0.0	3.9	0.1
Prop In Lane	0.21		0.58	0.17		0.17	1.00		1.00	1.00		1.00
Lane Grp Cap(c), veh/h	200	0	0	209	0	0	91	2266	1014	4	2090	935
V/C Ratio(X)	0.31	0.00	0.00	0.06	0.00	0.00	0.55	0.21	0.00	0.26	0.29	0.01
Avail Cap(c_a), veh/h	992	0	0	1058	0	0	503	2266	1014	503	2090	935
HCM Platoon Ratio	1.00	1.00	1.00	1.00	1.00	1.00	1.00	1.00	1.00	1.00	1.00	1.00
Upstream Filter(I)	1.00	0.00	0.00	1.00	0.00	0.00	1.00	1.00	1.00	1.00	1.00	1.00
Uniform Delay (d), s/veh	21.0	0.0	0.0	20.3	0.0	0.0	21.4	3.5	3.0	23.0	4.7	3.9
Incr Delay (d2), s/veh	0.9	0.0	0.0	0.1	0.0	0.0	5.1	0.2	0.0	32.5	0.3	0.0
Initial Q Delay(d3),s/veh	0.0	0.0	0.0	0.0	0.0	0.0	0.0	0.0	0.0	0.0	0.0	0.0
%ile BackOfQ(50%),veh/ln0.8	0.0	0.0	0.0	0.1	0.0	0.0	0.8	1.3	0.0	0.0	1.9	0.0
LnGrp Delay(d),s/veh	21.8	0.0	0.0	20.4	0.0	0.0	26.5	3.7	3.0	55.6	5.0	3.9
LnGrp LOS	C			C			C	A	A	E	A	A
Approach Vol, veh/h		62			12			526			604	
Approach Delay, s/veh		21.8			20.4			5.8			5.1	
Approach LOS		C			C			A			A	
Timer	1	2	3	4	5	6	7	8				
Assigned Phs	1	2		4	5	6		8				
Phs Duration (G+Y+Rc), s	34.1			7.6	6.9	31.8		7.6				
Change Period (Y+Rc), s	4.5	4.5		4.5	4.5	4.5		4.5				
Max Green Setting (Gmax), s	27.3			26.1	13.1	27.3		26.1				
Max Q Clear Time (g_c+1/2)Q	4.8			3.7	3.3	5.9		2.3				
Green Ext Time (p_c), s	0.0	3.2		0.3	0.1	4.1		0.0				
Intersection Summary												
HCM 2010 Ctrl Delay			6.4									
HCM 2010 LOS			A									

Intersection												
Int Delay, s/veh	0.3											
Movement	EBL	EBT	EBR	WBL	WBT	WBR	NBL	NBT	NBR	SBL	SBT	SBR
Lane Configurations		⇄			⇄			⇄			⇄	
Traffic Vol, veh/h	0	0	0	1	2	12	1	539	9	7	547	0
Future Vol, veh/h	0	0	0	1	2	12	1	539	9	7	547	0
Conflicting Peds, #/hr	0	0	0	0	0	0	0	0	0	0	0	0
Sign Control	Stop	Stop	Stop	Stop	Stop	Stop	Free	Free	Free	Free	Free	Free
RT Channelized	-	-	None	-	-	None	-	-	None	-	-	None
Storage Length	-	-	-	-	-	-	-	-	-	-	-	-
Veh In Median Storage, #	-	0	-	-	0	-	-	0	-	-	0	-
Grade, %	-	0	-	-	0	-	-	0	-	-	0	-
Peak Hour Factor	92	92	92	92	92	92	92	92	92	92	92	92
Heavy Vehicles, %	2	2	2	2	2	2	2	2	2	2	2	2
Mvmt Flow	0	0	0	1	2	13	1	566	10	8	595	0

Major/Minor	Minor2		Minor1		Major1			Major2				
Conflicting Flow All	907	1209	298	907	1204	298	595	0	0	596	0	0
Stage 1	611	611	-	593	593	-	-	-	-	-	-	-
Stage 2	296	598	-	314	611	-	-	-	-	-	-	-
Critical Hdwy	7.54	6.54	6.94	7.54	6.54	6.94	4.14	-	-	4.14	-	-
Critical Hdwy Stg 1	6.54	5.54	-	6.54	5.54	-	-	-	-	-	-	-
Critical Hdwy Stg 2	6.54	5.54	-	6.54	5.54	-	-	-	-	-	-	-
Follow-up Hdwy	3.52	4.02	3.32	3.52	4.02	3.32	2.22	-	-	2.22	-	-
Pot Cap-1 Maneuver	231	182	698	231	183	698	977	-	-	976	-	-
Stage 1	448	482	-	459	492	-	-	-	-	-	-	-
Stage 2	688	489	-	671	482	-	-	-	-	-	-	-
Platoon blocked, %	-	-	-	-	-	-	-	-	-	-	-	-
Mov Cap-1 Maneuver	222	179	698	228	180	698	977	-	-	976	-	-
Mov Cap-2 Maneuver	222	179	-	228	180	-	-	-	-	-	-	-
Stage 1	447	476	-	468	491	-	-	-	-	-	-	-
Stage 2	671	488	-	663	476	-	-	-	-	-	-	-

Approach	EB	WB	NB	SB
HCM Control Delay, s	0	13.1	0	0.2
HCM LOS	A	B		

Minor Lane/Major Mvmt	NBL	NBT	NBR	EBLn1	WB Ln1	SBL	SBT	SBR
Capacity (veh/h)	977	-	-	-	459	978	-	-
HCM Lane V/C Ratio	0.001	-	-	-	0.036	0.008	-	-
HCM Control Delay (s)	8.7	0	-	0	13.1	8.7	0.1	-
HCM Lane LOS	A	A	-	A	B	A	A	-
HCM 95th %tile Q(veh)	0	-	-	-	0.1	0	-	-

HCM 2010 Signalized Intersection Summary
4: Harris Road & Dogwood Rd

Ex AM
09/06/2018

	↖	→	↘	↙	←	↗	↘	↑	↙	↘	↓	↖
Movement	EBL	EBT	EBR	WBL	WBT	WBR	NBL	NBT	NBR	SBL	SBT	SBR
Lane Configurations		↕			↕			↕			↕	
Traffic Volume (veh/h)	2	0	3	2	21	4	0	100	2	2	160	0
Future Volume (veh/h)	2	0	3	2	21	4	0	100	2	2	160	0
Number	7	4	14	3	8	18	5	2	12	1	6	16
Initial Q (Qb), veh	0	0	0	0	0	0	0	0	0	0	0	0
Ped-Bike Adj(A_pbT)	1.00		1.00	1.00		1.00	1.00		1.00	1.00		1.00
Parking Bus, Adj	1.00		1.00	1.00		1.00	1.00		1.00	1.00		1.00
Adj Sat Flow, veh/h/ln	1900	1863	1900	1900	1863	1900	1900	1863	1900	1900	1863	1900
Adj Flow Rate, veh/h	2	0	3	2	23	4	0	109	2	2	174	0
Adj No. of Lanes	0	1	0	0	1	0	0	1	0	0	1	0
Peak Hour Factor	0.92	0.92	0.92	0.92	0.92	0.92	0.92	0.92	0.92	0.92	0.92	0.92
Percent Heavy Veh, %	2	2	2	2	2	2	2	2	2	2	2	2
Cap, veh/h	312	44	366	100	809	100	0	729	13	83	743	0
Arrive On Green	0.40	0.00	0.40	0.40	0.40	0.40	0.00	0.40	0.40	0.40	0.40	0.00
Sat Flow, veh/h	499	111	915	35	1523	249	0	1823	33	4	1857	0
Grp Volume(v), veh/h	5	0	0	29	0	0	0	0	111	176	0	0
Grp Sat Flow(s),veh/h/ln	1526	0	0	1807	0	0	0	0	1857	1861	0	0
Q Serve(g_s), s	0.0	0.0	0.0	0.0	0.0	0.0	0.0	0.0	1.7	0.0	0.0	0.0
Cycle Q Clear(g_c), s	0.1	0.0	0.0	0.4	0.0	0.0	0.0	0.0	1.7	2.8	0.0	0.0
Prop In Lane	0.40		0.60	0.07		0.14	0.00		0.02	0.01		0.00
Lane Grp Cap(c), veh/h	722	0	0	808	0	0	0	0	743	825	0	0
V/C Ratio(X)	0.01	0.00	0.00	0.04	0.00	0.00	0.00	0.00	0.15	0.21	0.00	0.00
Avail Cap(c_a), veh/h	722	0	0	808	0	0	0	0	743	825	0	0
HCM Platoon Ratio	1.00	1.00	1.00	1.00	1.00	1.00	1.00	1.00	1.00	1.00	1.00	1.00
Upstream Filter(I)	1.00	0.00	0.00	1.00	0.00	0.00	0.00	0.00	1.00	1.00	0.00	0.00
Uniform Delay (d), s/veh	8.1	0.0	0.0	8.2	0.0	0.0	0.0	0.0	8.8	8.9	0.0	0.0
Incr Delay (d2), s/veh	0.0	0.0	0.0	0.1	0.0	0.0	0.0	0.0	0.4	0.6	0.0	0.0
Initial Q Delay(d3),s/veh	0.0	0.0	0.0	0.0	0.0	0.0	0.0	0.0	0.0	0.0	0.0	0.0
%ile BackOfQ(50%),veh/ln	0.0	0.0	0.0	0.2	0.0	0.0	0.0	0.0	1.0	1.6	0.0	0.0
LnGrp Delay(d),s/veh	8.1	0.0	0.0	8.3	0.0	0.0	0.0	0.0	9.0	9.5	0.0	0.0
LnGrp LOS	A			A					A	A		
Approach Vol, veh/h		5			29			111			176	
Approach Delay, s/veh		8.1			8.3			9.0			9.5	
Approach LOS		A			A			A			A	
Timer	1	2	3	4	5	6	7	8				
Assigned Phs		2		4		6		8				
Phs Duration (G+Y+Rc), s		22.5		22.5		22.5		22.5				
Change Period (Y+Rc), s		4.5		4.5		4.5		4.5				
Max Green Setting (Gmax), s		18.0		18.0		18.0		18.0				
Max Q Clear Time (g_c+1), s		3.7		2.1		4.8		2.4				
Green Ext Time (p_c), s		0.4		0.0		0.7		0.1				
Intersection Summary												
HCM 2010 Ctrl Delay				9.2								
HCM 2010 LOS				A								

HCM 2010 Signalized Intersection Summary
5: SR-111 & Harris Road

Ex AM
09/06/2018

Movement	EBL	EBT	EBR	WBL	WBT	WBR	NBL	NBT	NBR	SBL	SBT	SBR
Lane Configurations		↕			↕		↖	↗	↖	↗	↖	↗
Traffic Volume (veh/h)	6	8	3	2	8	0	22	471	0	1	566	5
Future Volume (veh/h)	6	8	3	2	8	0	22	471	0	1	566	5
Number	7	4	14	3	8	18	5	2	12	1	6	16
Initial Q (Qb), veh	0	0	0	0	0	0	0	0	0	0	0	0
Ped-Bike Adj(A_pbT)	1.00		1.00	1.00		1.00	1.00		1.00	1.00		1.00
Parking Bus, Adj	1.00	1.00	1.00	1.00	1.00	1.00	1.00	1.00	1.00	1.00	1.00	1.00
Adj Sat Flow, veh/h/ln	1900	1863	1900	1900	1863	1900	1863	1863	1863	1863	1863	1863
Adj Flow Rate, veh/h	7	9	3	2	9	0	24	512	0	1	615	5
Adj No. of Lanes	0	1	0	0	1	0	1	2	1	1	2	1
Peak Hour Factor	0.92	0.92	0.92	0.92	0.92	0.92	0.92	0.92	0.92	0.92	0.92	0.92
Percent Heavy Veh, %	2	2	2	2	2	2	2	2	2	2	2	2
Cap, veh/h	116	27	9	93	49	0	50	2491	1114	3	2396	1072
Arrive On Green	0.03	0.03	0.03	0.03	0.03	0.00	0.03	0.70	0.00	0.00	0.68	0.68
Sat Flow, veh/h	610	784	261	324	1460	0	1774	3539	1583	1774	3539	1583
Grp Volume(v), veh/h	19	0	0	11	0	0	24	512	0	1	615	5
Grp Sat Flow(s),veh/h/ln	1863	0	0	1785	0	0	1774	1770	1583	1774	1770	1583
Q Serve(g_s), s	0.3	0.0	0.0	0.0	0.0	0.0	0.7	2.6	0.0	0.0	3.5	0.1
Cycle Q Clear(g_c), s	0.6	0.0	0.0	0.3	0.0	0.0	0.7	2.6	0.0	0.0	3.5	0.1
Prop In Lane	0.37		0.16	0.18		0.00	1.00		1.00	1.00		1.00
Lane Grp Cap(c), veh/h	151	0	0	143	0	0	50	2491	1114	3	2396	1072
V/C Ratio(X)	0.13	0.00	0.00	0.08	0.00	0.00	0.48	0.21	0.00	0.29	0.26	0.00
Avail Cap(c_a), veh/h	1225	0	0	1306	0	0	172	2491	1114	172	2396	1072
HCM Platoon Ratio	1.00	1.00	1.00	1.00	1.00	1.00	1.00	1.00	1.00	1.00	1.00	1.00
Upstream Filter(I)	1.00	0.00	0.00	1.00	0.00	0.00	1.00	1.00	0.00	1.00	1.00	1.00
Uniform Delay (d), s/veh	24.4	0.0	0.0	24.3	0.0	0.0	24.8	2.7	0.0	25.8	3.3	2.7
Incr Delay (d2), s/veh	0.4	0.0	0.0	0.2	0.0	0.0	7.0	0.2	0.0	41.3	0.3	0.0
Initial Q Delay(d3),s/veh	0.0	0.0	0.0	0.0	0.0	0.0	0.0	0.0	0.0	0.0	0.0	0.0
%ile BackOfQ(50%),veh/ln	0.3	0.0	0.0	0.2	0.0	0.0	0.4	1.3	0.0	0.1	1.8	0.0
LnGrp Delay(d),s/veh	24.8	0.0	0.0	24.5	0.0	0.0	31.7	2.8	0.0	67.1	3.5	2.7
LnGrp LOS	C			C			C	A		E	A	A
Approach Vol, veh/h		19			11			536			621	
Approach Delay, s/veh		24.8			24.5			4.1			3.6	
Approach LOS		C			C			A			A	
Timer	1	2	3	4	5	6	7	8				
Assigned Phs	1	2		4	5	6		8				
Phs Duration (G+Y+Rc), s	4.6	40.9		6.3	6.0	39.5		6.3				
Change Period (Y+Rc), s	4.5	4.5		4.5	4.5	4.5		4.5				
Max Green Setting (Gmax), s	35.0			36.0	5.0	35.0		36.0				
Max Q Clear Time (g_c+1.0), s	4.6			2.6	2.7	5.5		2.3				
Green Ext Time (p_c), s	0.0	3.7		0.1	0.0	4.6		0.0				
Intersection Summary												
HCM 2010 Ctrl Delay				4.4								
HCM 2010 LOS				A								

HCM 2010 Signalized Intersection Summary
6: SR-86 & Worthington Road

Ex AM
09/06/2018

	↖	→	↗	↖	←	↗	↖	↑	↗	↘	↓	↖
Movement	EBL	EBT	EBR	WBL	WBT	WBR	NBL	NBT	NBR	SBL	SBT	SBR
Lane Configurations		↖	↗		↖	↗	↖	↑	↗	↘	↑	↖
Traffic Volume (veh/h)	67	152	164	67	120	82	103	518	57	46	804	78
Future Volume (veh/h)	67	152	164	67	120	82	103	518	57	46	804	78
Number	7	4	14	3	8	18	5	2	12	1	6	16
Initial Q (Qb), veh	0	0	0	0	0	0	0	0	0	0	0	0
Ped-Bike Adj(A_pbT)	1.00		1.00	1.00		1.00	1.00		1.00	1.00		1.00
Parking Bus, Adj	1.00	1.00	1.00	1.00	1.00	1.00	1.00	1.00	1.00	1.00	1.00	1.00
Adj Sat Flow, veh/h/n	1900	1863	1863	1900	1863	1863	1863	1863	1900	1863	1863	1900
Adj Flow Rate, veh/h	73	165	178	73	130	89	112	563	62	50	874	85
Adj No. of Lanes	0	1	1	0	1	1	1	2	0	1	2	0
Peak Hour Factor	0.92	0.92	0.92	0.92	0.92	0.92	0.92	0.92	0.92	0.92	0.92	0.92
Percent Heavy Veh, %	2	2	2	2	2	2	2	2	2	2	2	2
Cap, veh/h	90	204	254	92	164	222	142	1435	158	72	1326	129
Arrive On Green	0.16	0.16	0.16	0.14	0.14	0.14	0.08	0.45	0.45	0.04	0.41	0.41
Sat Flow, veh/h	563	1272	1583	658	1172	1583	1774	3217	353	1774	3259	317
Grp Volume(v), veh/h	238	0	178	203	0	89	112	309	316	50	475	484
Grp Sat Flow(s),veh/h/n	1835	0	1583	1830	0	1583	1774	1770	1800	1774	1770	1807
Q Serve(g_s), s	10.6	0.0	9.0	9.1	0.0	4.3	5.3	10.0	10.0	2.4	18.5	18.5
Cycle Q Clear(g_c), s	10.6	0.0	9.0	9.1	0.0	4.3	5.3	10.0	10.0	2.4	18.5	18.5
Prop In Lane	0.31		1.00	0.36		1.00	1.00		0.20	1.00		0.18
Lane Grp Cap(c), veh/h	295	0	254	257	0	222	142	790	803	72	720	735
V/C Ratio(X)	0.81	0.00	0.70	0.79	0.00	0.40	0.79	0.39	0.39	0.69	0.66	0.66
Avail Cap(c_a), veh/h	400	0	345	399	0	345	219	790	803	148	720	735
HCM Platoon Ratio	1.00	1.00	1.00	1.00	1.00	1.00	1.00	1.00	1.00	1.00	1.00	1.00
Upstream Filter(I)	1.00	0.00	1.00	1.00	0.00	1.00	1.00	1.00	1.00	1.00	1.00	1.00
Uniform Delay (d), s/veh	34.4	0.0	33.7	35.3	0.0	33.3	38.3	15.8	15.8	40.2	20.4	20.4
Incr Delay (d2), s/veh	8.5	0.0	3.9	5.8	0.0	1.2	9.9	1.5	1.4	11.1	4.7	4.6
Initial Q Delay(d3),s/veh	0.0	0.0	0.0	0.0	0.0	0.0	0.0	0.0	0.0	0.0	0.0	0.0
%ile BackOfQ(50%),veh/ln	6.1	0.0	4.2	5.0	0.0	2.0	3.0	5.1	5.2	1.4	9.9	10.1
LnGrp Delay(d),s/veh	42.9	0.0	37.6	41.0	0.0	34.4	48.2	17.2	17.2	51.3	25.1	25.0
LnGrp LOS	D		D	D		C	D	B	B	D	C	C
Approach Vol, veh/h		416			292			737			1009	
Approach Delay, s/veh		40.6			39.0			21.9			26.4	
Approach LOS		D			D			C			C	
Timer	1	2	3	4	5	6	7	8				
Assigned Phs	1	2		4	5	6		8				
Phs Duration (G+Y+Rc), s	0	42.4		18.1	11.3	39.1		16.4				
Change Period (Y+Rc), s	4.5	4.5		4.5	4.5	4.5		4.5				
Max Green Setting (Gmax), s		37.9		18.5	10.5	34.5		18.5				
Max Q Clear Time (g_c+1), s		12.0		12.6	7.3	20.5		11.1				
Green Ext Time (p_c), s		0.0		4.1	1.0	0.1		5.4				
Intersection Summary												
HCM 2010 Ctrl Delay				29.0								
HCM 2010 LOS				C								

HCM 2010 Signalized Intersection Summary
 7: SR-111 & Worthington Rd

Ex AM
 09/06/2018

Movement	EBL	EBT	EBR	WBL	WBT	WBR	NBL	NBT	NBR	SBL	SBT	SBR
Lane Configurations		⇄			⇄		↖	↗	↖	↗	↖	↗
Traffic Volume (veh/h)	27	50	98	4	69	15	75	440	2	4	446	132
Future Volume (veh/h)	27	50	98	4	69	15	75	440	2	4	446	132
Number	7	4	14	3	8	18	5	2	12	1	6	16
Initial Q (Qb), veh	0	0	0	0	0	0	0	0	0	0	0	0
Ped-Bike Adj(A_pbT)	1.00		1.00	1.00		1.00	1.00		1.00	1.00		1.00
Parking Bus, Adj	1.00	1.00	1.00	1.00	1.00	1.00	1.00	1.00	1.00	1.00	1.00	1.00
Adj Sat Flow, veh/h/ln	1900	1863	1900	1900	1863	1900	1863	1863	1863	1863	1863	1863
Adj Flow Rate, veh/h	29	54	107	4	75	16	82	478	0	4	485	0
Adj No. of Lanes	0	1	0	0	1	0	1	2	1	1	2	1
Peak Hour Factor	0.92	0.92	0.92	0.92	0.92	0.92	0.92	0.92	0.92	0.92	0.92	0.92
Percent Heavy Veh, %	2	2	2	2	2	2	2	2	2	2	2	2
Cap, veh/h	103	91	150	75	239	49	117	2040	913	10	1825	817
Arrive On Green	0.16	0.16	0.16	0.16	0.16	0.16	0.07	0.58	0.00	0.01	0.52	0.00
Sat Flow, veh/h	153	561	920	27	1468	303	1774	3539	1583	1774	3539	1583
Grp Volume(v), veh/h	190	0	0	95	0	0	82	478	0	4	485	0
Grp Sat Flow(s), veh/h/ln	1634	0	0	1798	0	0	1774	1770	1583	1774	1770	1583
Q Serve(g_s), s	2.5	0.0	0.0	0.0	0.0	0.0	2.4	3.5	0.0	0.1	4.1	0.0
Cycle Q Clear(g_c), s	5.8	0.0	0.0	2.5	0.0	0.0	2.4	3.5	0.0	0.1	4.1	0.0
Prop In Lane	0.15		0.56	0.04		0.17	1.00		1.00	1.00		1.00
Lane Grp Cap(c), veh/h	345	0	0	364	0	0	117	2040	913	10	1825	817
V/C Ratio(X)	0.55	0.00	0.00	0.26	0.00	0.00	0.70	0.23	0.00	0.42	0.27	0.00
Avail Cap(c_a), veh/h	872	0	0	948	0	0	439	2040	913	439	1825	817
HCM Platoon Ratio	1.00	1.00	1.00	1.00	1.00	1.00	1.00	1.00	1.00	1.00	1.00	1.00
Upstream Filter(I)	1.00	0.00	0.00	1.00	0.00	0.00	1.00	1.00	0.00	1.00	1.00	0.00
Uniform Delay (d), s/veh	20.9	0.0	0.0	19.6	0.0	0.0	24.2	5.5	0.0	26.2	7.2	0.0
Incr Delay (d2), s/veh	1.4	0.0	0.0	0.4	0.0	0.0	7.3	0.3	0.0	26.5	0.4	0.0
Initial Q Delay(d3),s/veh	0.0	0.0	0.0	0.0	0.0	0.0	0.0	0.0	0.0	0.0	0.0	0.0
%ile BackOfQ(50%),veh/ln	2.8	0.0	0.0	1.3	0.0	0.0	1.4	1.7	0.0	0.1	2.0	0.0
LnGrp Delay(d),s/veh	22.3	0.0	0.0	19.9	0.0	0.0	31.5	5.8	0.0	52.7	7.5	0.0
LnGrp LOS	C			B			C	A		D	A	
Approach Vol, veh/h	190			95			580			489		
Approach Delay, s/veh	22.3			19.9			9.5			7.9		
Approach LOS	C			B			A			A		
Timer	1	2	3	4	5	6	7	8				
Assigned Phs	1	2		4	5	6		8				
Phs Duration (G+Y+Rc), s	35.0			13.1	8.0	31.8		13.1				
Change Period (Y+Rc), s	4.5			4.5	4.5	4.5		4.5				
Max Green Setting (Gmax), s	27.3			26.1	13.1	27.3		26.1				
Max Q Clear Time (g_c+T2), s	5.5			7.8	4.4	6.1		4.5				
Green Ext Time (p_c), s	0.0	3.2		1.0	0.1	3.2		0.4				
Intersection Summary												
HCM 2010 Ctrl Delay				11.5								
HCM 2010 LOS				B								

HCM 2010 Signalized Intersection Summary
1: SR-86 & Keystone Road

Ex PM
09/06/2018

Movement	EBL	EBT	EBR	WBL	WBT	WBR	NBL	NBT	NBR	SBL	SBT	SBR
Lane Configurations		↔			↔		↖	↗	↖	↖	↗	↖
Traffic Volume (veh/h)	31	13	20	19	22	39	17	574	18	42	563	15
Future Volume (veh/h)	31	13	20	19	22	39	17	574	18	42	563	15
Number	7	4	14	3	8	18	5	2	12	1	6	16
Initial Q (Qb), veh	0	0	0	0	0	0	0	0	0	0	0	0
Ped-Bike Adj(A_pbT)	1.00		1.00	1.00		1.00	1.00		1.00	1.00		1.00
Parking Bus, Adj	1.00	1.00	1.00	1.00	1.00	1.00	1.00	1.00	1.00	1.00	1.00	1.00
Adj Sat Flow, veh/h/in	1900	1863	1900	1900	1863	1900	1863	1863	1863	1863	1863	1863
Adj Flow Rate, veh/h	34	14	22	21	24	42	18	624	20	46	612	16
Adj No. of Lanes	0	1	0	0	1	0	1	2	1	1	2	1
Peak Hour Factor	0.92	0.92	0.92	0.92	0.92	0.92	0.92	0.92	0.92	0.92	0.92	0.92
Percent Heavy Veh, %	2	2	2	2	2	2	2	2	2	2	2	2
Cap, veh/h	154	38	44	106	47	68	39	2221	994	81	2306	1032
Arrive On Green	0.08	0.08	0.08	0.08	0.08	0.08	0.02	0.63	0.63	0.05	0.65	0.65
Sat Flow, veh/h	693	453	525	308	556	806	1774	3539	1583	1774	3539	1583
Grp Volume(v), veh/h	70	0	0	87	0	0	18	624	20	46	612	16
Grp Sat Flow(s), veh/h/in	1671	0	0	1870	0	0	1774	1770	1583	1774	1770	1583
Q Serve(g_s), s	0.0	0.0	0.0	0.6	0.0	0.0	0.6	4.4	0.3	1.4	4.1	0.2
Cycle Q Clear(g_c), s	2.1	0.0	0.0	2.7	0.0	0.0	0.6	4.4	0.3	1.4	4.1	0.2
Prop In Lane	0.49		0.31	0.24		0.48	1.00		1.00	1.00		1.00
Lane Grp Cap(c), veh/h	237	0	0	221	0	0	39	2221	994	81	2306	1032
V/C Ratio(X)	0.30	0.00	0.00	0.39	0.00	0.00	0.47	0.28	0.02	0.57	0.27	0.02
Avail Cap(c_a), veh/h	1073	0	0	1112	0	0	159	2221	994	159	2306	1032
HCM Platoon Ratio	1.00	1.00	1.00	1.00	1.00	1.00	1.00	1.00	1.00	1.00	1.00	1.00
Upstream Filter(I)	1.00	0.00	0.00	1.00	0.00	0.00	1.00	1.00	1.00	1.00	1.00	1.00
Uniform Delay (d), s/veh	24.3	0.0	0.0	24.6	0.0	0.0	27.0	4.7	3.9	26.1	4.1	3.4
Incr Delay (d2), s/veh	0.7	0.0	0.0	1.1	0.0	0.0	8.4	0.3	0.0	6.1	0.3	0.0
Initial Q Delay(d3),s/veh	0.0	0.0	0.0	0.0	0.0	0.0	0.0	0.0	0.0	0.0	0.0	0.0
%ile BackOfQ(50%),veh/ln	1.1	0.0	0.0	1.4	0.0	0.0	0.4	2.3	0.1	0.8	2.0	0.1
LnGrp Delay(d),s/veh	25.0	0.0	0.0	25.7	0.0	0.0	35.4	5.0	4.0	32.2	4.4	3.4
LnGrp LOS	C			C			D	A	A	C	A	A
Approach Vol, veh/h		70			87			662			674	
Approach Delay, s/veh		25.0			25.7			5.8			6.2	
Approach LOS		C			C			A			A	
Timer	1	2	3	4	5	6	7	8				
Assigned Phs	1	2		4	5	6		8				
Phs Duration (G+Y+Rc), s	7.0	39.5		9.2	5.7	40.8		9.2				
Change Period (Y+Rc), s	4.5	4.5		4.5	4.5	4.5		4.5				
Max Green Setting (Gmax), s	5.0	35.0		36.0	5.0	35.0		36.0				
Max Q Clear Time (g_c+1), s	3.4	6.4		4.1	2.6	6.1		4.7				
Green Ext Time (p_c), s	0.0	4.7		0.4	0.0	4.6		0.5				
Intersection Summary												
HCM 2010 Ctrl Delay				8.1								
HCM 2010 LOS				A								

HCM 2010 Signalized Intersection Summary
2: SR-111 & Keystone Road

Ex PM
09/06/2018

Movement	EBL	EBT	EBR	WBL	WBT	WBR	NBL	NBT	NBR	SBL	SBT	SBR
Lane Configurations		↔			↔		↖	↗	↖	↗	↖	↗
Traffic Volume (veh/h)	6	7	54	2	8	0	24	350	2	4	629	3
Future Volume (veh/h)	6	7	54	2	8	0	24	350	2	4	629	3
Number	7	4	14	3	8	18	5	2	12	1	6	18
Initial Q (Qb), veh	0	0	0	0	0	0	0	0	0	0	0	0
Ped-Bike Adj(A_pbT)	1.00		1.00	1.00		1.00	1.00		1.00	1.00		1.00
Parking Bus, Adj	1.00	1.00	1.00	1.00	1.00	1.00	1.00	1.00	1.00	1.00	1.00	1.00
Adj Sat Flow, veh/h/ln	1900	1863	1900	1900	1863	1900	1863	1863	1863	1863	1863	1863
Adj Flow Rate, veh/h	7	8	59	2	9	0	26	380	2	4	684	3
Adj No. of Lanes	0	1	0	0	1	0	1	2	1	1	2	1
Peak Hour Factor	0.92	0.92	0.92	0.92	0.92	0.92	0.92	0.92	0.92	0.92	0.92	0.92
Percent Heavy Veh, %	2	2	2	2	2	2	2	2	2	2	2	2
Cap, veh/h	95	15	92	110	115	0	55	2214	990	10	2124	950
Arrive On Green	0.07	0.07	0.07	0.07	0.07	0.00	0.03	0.63	0.63	0.01	0.60	0.60
Sat Flow, veh/h	117	207	1275	224	1586	0	1774	3539	1583	1774	3539	1583
Grp Volume(v), veh/h	74	0	0	11	0	0	26	380	2	4	684	3
Grp Sat Flow(s),veh/h/ln1599	0	0	1809	0	0	1774	1770	1583	1774	1770	1583	
Q Serve(g_s), s	1.3	0.0	0.0	0.0	0.0	0.0	0.7	2.0	0.0	0.1	4.4	0.0
Cycle Q Clear(g_c), s	2.0	0.0	0.0	0.3	0.0	0.0	0.7	2.0	0.0	0.1	4.4	0.0
Prop In Lane	0.09		0.80	0.18		0.00	1.00		1.00	1.00		1.00
Lane Grp Cap(c), veh/h	202	0	0	224	0	0	55	2214	990	10	2124	950
V/C Ratio(X)	0.37	0.00	0.00	0.05	0.00	0.00	0.48	0.17	0.00	0.42	0.32	0.00
Avail Cap(c_a), veh/h	999	0	0	1095	0	0	511	2214	990	511	2124	950
HCM Platoon Ratio	1.00	1.00	1.00	1.00	1.00	1.00	1.00	1.00	1.00	1.00	1.00	1.00
Upstream Filter(!)	1.00	0.00	0.00	1.00	0.00	0.00	1.00	1.00	1.00	1.00	1.00	1.00
Uniform Delay (d), s/veh	20.5	0.0	0.0	19.7	0.0	0.0	21.7	3.6	3.2	22.6	4.5	3.6
Incr Delay (d2), s/veh	1.1	0.0	0.0	0.1	0.0	0.0	6.3	0.2	0.0	26.2	0.4	0.0
Initial Q Delay(d3),s/veh	0.0	0.0	0.0	0.0	0.0	0.0	0.0	0.0	0.0	0.0	0.0	0.0
%ile BackOfQ(50%),veh/ln1.0	0.0	0.0	0.0	0.1	0.0	0.0	0.4	1.1	0.0	0.1	2.2	0.0
LnGrp Delay(d),s/veh	21.6	0.0	0.0	19.8	0.0	0.0	26.0	3.7	3.2	48.8	4.9	3.7
LnGrp LOS	C			B			C	A	A	D	A	A
Approach Vol, veh/h		74			11			408			691	
Approach Delay, s/veh		21.6			19.8			5.3			5.2	
Approach LOS		C			B			A			A	
Timer	1	2	3	4	5	6	7	8				
Assigned Phs	1	2		4	5	6		8				
Phs Duration (G+Y+Rc), s4.7		33.0		7.8	5.9	31.8		7.8				
Change Period (Y+Rc), s 4.5		4.5		4.5	4.5	4.5		4.5				
Max Green Setting (Gmax), s		27.3		26.1	13.1	27.3		26.1				
Max Q Clear Time (g_c+I1), s		4.0		4.0	2.7	6.4		2.3				
Green Ext Time (p_c), s		0.0		0.3	0.0	4.8		0.0				
Intersection Summary												
HCM 2010 Ctrl Delay				6.4								
HCM 2010 LOS				A								

Intersection												
Int Delay, s/veh	0.2											
Movement	EBL	EBT	EBR	WBL	WBT	WBR	NBL	NBT	NBR	SBL	SBT	SBR
Lane Configurations		↕			↕			↕			↕	
Traffic Vol, veh/h	0	0	0	4	2	1	0	606	6	7	591	0
Future Vol, veh/h	0	0	0	4	2	1	0	606	6	7	591	0
Conflicting Peds, #/hr	0	0	0	0	0	0	0	0	0	0	0	0
Sign Control	Stop	Stop	Stop	Stop	Stop	Stop	Free	Free	Free	Free	Free	Free
RT Channelized	-	-	None	-	-	None	-	-	None	-	-	None
Storage Length	-	-	-	-	-	-	-	-	-	-	-	-
Veh In Median Storage, #	-	0	-	-	0	-	-	0	-	-	0	-
Grade, %	-	0	-	-	0	-	-	0	-	-	0	-
Peak Hour Factor	92	92	92	92	92	92	92	92	92	92	92	92
Heavy Vehicles, %	2	2	2	2	2	2	2	2	2	2	2	2
Mvmt Flow	0	0	0	4	2	1	0	659	7	8	642	0

Major/Minor	Minor2	Minor1		Major1		Major2						
Conflicting Flow All	989	1324	321	1000	1321	333	642	0	0	666	0	0
Stage 1	658	658	-	663	663	-	-	-	-	-	-	-
Stage 2	331	666	-	337	658	-	-	-	-	-	-	-
Critical Hdwy	7.54	6.54	6.94	7.54	6.54	6.94	4.14	-	-	4.14	-	-
Critical Hdwy Stg 1	6.54	5.54	-	6.54	5.54	-	-	-	-	-	-	-
Critical Hdwy Stg 2	6.54	5.54	-	6.54	5.54	-	-	-	-	-	-	-
Follow-up Hdwy	3.52	4.02	3.32	3.52	4.02	3.32	2.22	-	-	2.22	-	-
Pot Cap-1 Maneuver	201	155	675	197	155	663	939	-	-	919	-	-
Stage 1	420	459	-	417	457	-	-	-	-	-	-	-
Stage 2	656	458	-	651	459	-	-	-	-	-	-	-
Platoon blocked, %	-	-	-	-	-	-	-	-	-	-	-	-
Mov Cap-1 Maneuver	196	153	675	196	153	663	939	-	-	919	-	-
Mov Cap-2 Maneuver	196	153	-	196	153	-	-	-	-	-	-	-
Stage 1	420	453	-	417	457	-	-	-	-	-	-	-
Stage 2	652	456	-	642	453	-	-	-	-	-	-	-

Approach	EB	WB	NB	SB
HCM Control Delay, s	0	23.8	0	0.2
HCM LOS	A	C		

Minor Lane/Major Mvmt	NBL	NBT	NBR	EBLn1	WBLn1	SBL	SBT	SBR
Capacity (veh/h)	939	-	-	-	199	919	-	-
HCM Lane V/C Ratio	-	-	-	-	0.038	0.008	-	-
HCM Control Delay (s)	0	-	-	0	23.8	9	0.1	-
HCM Lane LOS	A	-	-	A	C	A	A	-
HCM 95th %tile Q(veh)	0	-	-	-	0.1	0	-	-

HCM 2010 Signalized Intersection Summary
4: Harris Road & Dogwood Rd

Ex PM
09/06/2018

Movement	EBL	EBT	EBR	WBL	WBT	WBR	NBL	NBT	NBR	SBL	SBT	SBR
Lane Configurations		↕			↕			↕			↕	
Traffic Volume (veh/h)	0	12	1	10	7	2	0	119	1	4	202	3
Future Volume (veh/h)	0	12	1	10	7	2	0	119	1	4	202	3
Number	7	4	14	3	8	18	5	2	12	1	6	16
Initial Q (Qb), veh	0	0	0	0	0	0	0	0	0	0	0	0
Ped-Bike Adj(A_pbT)	1.00		1.00	1.00		1.00	1.00		1.00	1.00		1.00
Parking Bus, Adj	1.00	1.00	1.00	1.00	1.00	1.00	1.00	1.00	1.00	1.00	1.00	1.00
Adj Sat Flow, veh/h/ln	1900	1863	1900	1900	1863	1900	1900	1863	1900	1900	1863	1900
Adj Flow Rate, veh/h	0	13	1	11	8	2	0	129	1	4	220	3
Adj No. of Lanes	0	1	0	0	1	0	0	1	0	0	1	0
Peak Hour Factor	0.92	0.92	0.92	0.92	0.92	0.92	0.92	0.92	0.92	0.92	0.92	0.92
Percent Heavy Veh. %	2	2	2	2	2	2	2	2	2	2	2	2
Cap, veh/h	0	683	53	416	281	61	0	738	6	84	729	10
Arrive On Green	0.00	0.40	0.40	0.40	0.40	0.40	0.00	0.40	0.40	0.40	0.40	0.40
Sat Flow, veh/h	0	1708	131	735	702	151	0	1846	14	8	1823	25
Grp Volume(v), veh/h	0	0	14	21	0	0	0	0	130	227	0	0
Grp Sat Flow(s),veh/h/ln	0	0	1840	1589	0	0	0	0	1860	1855	0	0
Q Serve(g_s), s	0.0	0.0	0.2	0.0	0.0	0.0	0.0	0.0	2.0	0.0	0.0	0.0
Cycle Q Clear(g_c), s	0.0	0.0	0.2	0.3	0.0	0.0	0.0	0.0	2.0	3.8	0.0	0.0
Prop In Lane	0.00		0.07	0.52		0.10	0.00		0.01	0.02		0.01
Lane Grp Cap(c), veh/h	0	0	736	757	0	0	0	0	744	823	0	0
V/C Ratio(X)	0.00	0.00	0.02	0.03	0.00	0.00	0.00	0.00	0.17	0.28	0.00	0.00
Avail Cap(c_a), veh/h	0	0	736	757	0	0	0	0	744	823	0	0
HCM Platoon Ratio	1.00	1.00	1.00	1.00	1.00	1.00	1.00	1.00	1.00	1.00	1.00	1.00
Upstream Filter(I)	0.00	0.00	1.00	1.00	0.00	0.00	0.00	0.00	1.00	1.00	0.00	0.00
Uniform Delay (d), s/veh	0.0	0.0	8.2	8.2	0.0	0.0	0.0	0.0	8.7	9.2	0.0	0.0
Incr Delay (d2), s/veh	0.0	0.0	0.0	0.1	0.0	0.0	0.0	0.0	0.5	0.8	0.0	0.0
Initial Q Delay(d3),s/veh	0.0	0.0	0.0	0.0	0.0	0.0	0.0	0.0	0.0	0.0	0.0	0.0
%ile BackOfQ(50%),veh/ln	0.0	0.0	0.1	0.2	0.0	0.0	0.0	0.0	1.1	2.1	0.0	0.0
LnGrp Delay(d),s/veh	0.0	0.0	8.2	8.3	0.0	0.0	0.0	0.0	9.2	10.1	0.0	0.0
LnGrp LOS			A	A					A	B		
Approach Vol, veh/h		14			21			130			227	
Approach Delay, s/veh		8.2			8.3			9.2			10.1	
Approach LOS		A			A			A			B	
Timer	1	2	3	4	5	6	7	8				
Assigned Phs		2		4		6		8				
Phs Duration (G+Y+Rc), s		22.5		22.5		22.5		22.5				
Change Period (Y+Rc), s		4.5		4.5		4.5		4.5				
Max Green Setting (Gmax), s		18.0		18.0		18.0		18.0				
Max Q Clear Time (g_c+1), s		4.0		2.2		5.8		2.3				
Green Ext Time (p_c), s		0.5		0.0		0.9		0.0				
Intersection Summary												
HCM 2010 Ctrl Delay				9.6								
HCM 2010 LOS				A								

HCM 2010 Signalized Intersection Summary
5: SR-111 & Harris Road

Ex PM
09/06/2018

Movement	EBL	EBT	EBR	WBL	WBT	WBR	NBL	NBT	NBR	SBL	SBT	SBR
Lane Configurations		+			+			+	+		+	+
Traffic Volume (veh/h)	2	10	3	1	9	4	10	289	0	0	599	4
Future Volume (veh/h)	2	10	3	1	9	4	10	289	0	0	599	4
Number	7	4	14	3	8	18	5	2	12	1	6	16
Initial Q (Qb), veh	0	0	0	0	0	0	0	0	0	0	0	0
Ped-Bike Adj(A_pbT)	1.00		1.00	1.00		1.00	1.00		1.00	1.00		1.00
Parking Bus, Adj	1.00	1.00	1.00	1.00	1.00	1.00	1.00	1.00	1.00	1.00	1.00	1.00
Adj Sat Flow, veh/h/ln	1900	1863	1900	1900	1863	1900	1863	1863	1863	1863	1863	1863
Adj Flow Rate, veh/h	2	11	3	1	10	4	11	314	0	0	651	4
Adj No. of Lanes	0	1	0	0	1	0	1	2	1	1	2	1
Peak Hour Factor	0.92	0.92	0.92	0.92	0.92	0.92	0.92	0.92	0.92	0.92	0.92	0.92
Percent Heavy Veh, %	2	2	2	2	2	2	2	2	2	2	2	2
Cap, veh/h	87	42	11	79	41	16	25	2791	1249	3	2429	1087
Arrive On Green	0.03	0.03	0.03	0.03	0.03	0.03	0.01	0.79	0.00	0.00	0.69	0.69
Sat Flow, veh/h	220	1210	330	118	1180	472	1774	3539	1583	1774	3539	1583
Grp Volume(v), veh/h	16	0	0	15	0	0	11	314	0	0	651	4
Grp Sat Flow(s),veh/h/ln	1759	0	0	1770	0	0	1774	1770	1583	1774	1770	1583
Q Serve(g_s), s	0.0	0.0	0.0	0.0	0.0	0.0	0.3	1.0	0.0	0.0	3.6	0.0
Cycle Q Clear(g_c), s	0.4	0.0	0.0	0.4	0.0	0.0	0.3	1.0	0.0	0.0	3.6	0.0
Prop In Lane	0.12		0.19	0.07		0.27	1.00		1.00	1.00		1.00
Lane Grp Cap(c), veh/h	141	0	0	137	0	0	25	2791	1249	3	2429	1087
V/C Ratio(X)	0.11	0.00	0.00	0.11	0.00	0.00	0.44	0.11	0.00	0.00	0.27	0.00
Avail Cap(c_a), veh/h	1303	0	0	1306	0	0	174	2791	1249	174	2429	1087
HCM Platoon Ratio	1.00	1.00	1.00	1.00	1.00	1.00	1.00	1.00	1.00	1.00	1.00	1.00
Upstream Filter(I)	1.00	0.00	0.00	1.00	0.00	0.00	1.00	1.00	0.00	0.00	1.00	1.00
Uniform Delay (d), s/veh	24.0	0.0	0.0	23.9	0.0	0.0	24.9	1.2	0.0	0.0	3.1	2.5
Incr Delay (d2), s/veh	0.4	0.0	0.0	0.3	0.0	0.0	11.6	0.1	0.0	0.0	0.3	0.0
Initial Q Delay(d3),s/veh	0.0	0.0	0.0	0.0	0.0	0.0	0.0	0.0	0.0	0.0	0.0	0.0
%ile BackOfQ(50%),veh/ln	0.2	0.0	0.0	0.2	0.0	0.0	0.2	0.5	0.0	0.0	1.8	0.0
LnGrp Delay(d),s/veh	24.3	0.0	0.0	24.3	0.0	0.0	36.5	1.3	0.0	0.0	3.3	2.5
LnGrp LOS	C			C			D	A			A	A
Approach Vol, veh/h		16			15			325			655	
Approach Delay, s/veh		24.3			24.3			2.5			3.3	
Approach LOS		C			C			A			A	
Timer	1	2	3	4	5	6	7	8				
Assigned Pha	1	2		4	5	6		8				
Phs Duration (G+Y+Rc), s	0.0	44.7		6.3	5.2	39.5		6.3				
Change Period (Y+Rc), s	4.5	4.5		4.5	4.5	4.5		4.5				
Max Green Setting (Gmax), s	35.0			36.0	5.0	35.0		36.0				
Max Q Clear Time (g_c+T), s	3.0			2.4	2.3	5.6		2.4				
Green Ext Time (p_c), s	0.0	2.2		0.0	0.0	5.0		0.0				
Intersection Summary												
HCM 2010 Ctrl Delay				3.7								
HCM 2010 LOS				A								

HCM 2010 Signalized Intersection Summary
6: SR-86 & Worthington Road

Ex PM
09/06/2018

Movement	EBL	EBT	EBR	WBL	WBT	WBR	NBL	NBT	NBR	SBL	SBT	SBR
Lane Configurations		←	↗		←	↗	↖	↑	↖	↗	↑	↖
Traffic Volume (veh/h)	45	88	114	58	135	60	121	710	22	31	559	72
Future Volume (veh/h)	45	88	114	58	135	60	121	710	22	31	559	72
Number	7	4	14	3	8	18	5	2	12	1	6	16
Initial Q (Qb), veh	0	0	0	0	0	0	0	0	0	0	0	0
Ped-Bike Adj(A_pbT)	1.00		1.00	1.00		1.00	1.00		1.00	1.00		1.00
Parking Bus, Adj	1.00	1.00	1.00	1.00	1.00	1.00	1.00	1.00	1.00	1.00	1.00	1.00
Adj Sat Flow, veh/h/m	1900	1863	1863	1900	1863	1863	1863	1863	1900	1863	1863	1900
Adj Flow Rate, veh/h	49	96	124	63	147	65	132	772	24	34	608	78
Adj No. of Lanes	0	1	1	0	1	1	1	2	0	1	2	0
Peak Hour Factor	0.92	0.92	0.92	0.92	0.92	0.92	0.92	0.92	0.92	0.92	0.92	0.92
Percent Heavy Veh, %	2	2	2	2	2	2	2	2	2	2	2	2
Cap, veh/h	69	135	176	80	186	229	166	1709	53	59	1349	173
Arrive On Green	0.11	0.11	0.11	0.14	0.14	0.14	0.09	0.49	0.49	0.03	0.43	0.43
Sat Flow, veh/h	619	1213	1583	551	1285	1583	1774	3504	109	1774	3157	404
Grp Volume(v), veh/h	145	0	124	210	0	65	132	390	406	34	340	346
Grp Sat Flow(s), veh/h/m	1832	0	1583	1835	0	1583	1774	1770	1844	1774	1770	1791
Q Serve(g_s), s	6.2	0.0	6.1	8.9	0.0	3.0	5.9	11.7	11.7	1.5	11.0	11.1
Cycle Q Clear(g_c), s	6.2	0.0	6.1	8.9	0.0	3.0	5.9	11.7	11.7	1.5	11.0	11.1
Prop In Lane	0.34		1.00	0.30		1.00	1.00		0.06	1.00		0.23
Lane Grp Cap(c), veh/h	204	0	176	266	0	229	166	863	899	59	756	766
V/C Ratio(X)	0.71	0.00	0.70	0.79	0.00	0.28	0.80	0.45	0.45	0.58	0.45	0.45
Avail Cap(c_a), veh/h	420	0	363	421	0	363	231	863	899	156	756	766
HCM Platoon Ratio	1.00	1.00	1.00	1.00	1.00	1.00	1.00	1.00	1.00	1.00	1.00	1.00
Upstream Filter(I)	1.00	0.00	1.00	1.00	0.00	1.00	1.00	1.00	1.00	1.00	1.00	1.00
Uniform Delay (d), s/veh	34.6	0.0	34.6	33.3	0.0	30.8	35.8	13.6	13.6	38.5	16.4	16.4
Incr Delay (d2), s/veh	4.5	0.0	5.0	5.2	0.0	0.7	12.3	1.7	1.6	8.8	1.9	1.9
Initial Q Delay(d3), s/veh	0.0	0.0	0.0	0.0	0.0	0.0	0.0	0.0	0.0	0.0	0.0	0.0
%ile BackOfQ(50%), veh/m	8.4	0.0	2.9	4.9	0.0	1.3	3.5	6.0	6.3	0.9	5.8	5.9
LnGrp Delay(d), s/veh	39.1	0.0	39.6	38.5	0.0	31.4	48.1	15.3	15.2	47.2	18.3	18.3
LnGrp LOS	D		D	D		C	D	B	B	D	B	B
Approach Vol, veh/h		269			275			928			720	
Approach Delay, s/veh		39.4			36.9			19.9			19.7	
Approach LOS		D			D			B			B	
Timer	1	2	3	4	5	6	7	8				
Assigned Phs	1	2		4	5	6		8				
Phs Duration (G+Y+Rc), s	7.2	43.9		13.5	12.0	39.0		16.2				
Change Period (Y+Rc), s	4.5	4.5		4.5	4.5	4.5		4.5				
Max Green Setting (Gmax), s	37.9			18.5	10.5	34.5		18.5				
Max Q Clear Time (g_c+Tb), s	13.7			8.2	7.9	13.1		10.9				
Green Ext Time (p_c), s	0.0	5.3		0.8	0.1	4.4		0.8				
Intersection Summary												
HCM 2010 Ctrl Delay			24.4									
HCM 2010 LOS			C									

HCM 2010 Signalized Intersection Summary
7: SR-111 & Worthington Rd

Ex PM
09/06/2018

Movement	EBL	EBT	EBR	WBL	WBT	WBR	NBL	NBT	NBR	SBL	SBT	SBR
Lane Configurations		⇄			⇄		↖	↗	↖	↗	↖	↗
Traffic Volume (veh/h)	22	39	44	6	34	7	45	287	3	13	530	34
Future Volume (veh/h)	22	39	44	6	34	7	45	287	3	13	530	34
Number	7	4	14	3	8	18	5	2	12	1	6	16
Initial Q (Qb), veh	0	0	0	0	0	0	0	0	0	0	0	0
Ped-Bike Adj(A_pbT)	1.00		1.00	1.00		1.00	1.00		1.00	1.00		1.00
Parking Bus, Adj	1.00	1.00	1.00	1.00	1.00	1.00	1.00	1.00	1.00	1.00	1.00	1.00
Adj Sat Flow, veh/h/in	1900	1863	1900	1900	1863	1900	1863	1863	1863	1863	1863	1863
Adj Flow Rate, veh/h	24	42	48	7	37	8	49	290	0	14	576	0
Adj No. of Lanes	0	1	0	0	1	0	1	2	1	1	2	1
Peak Hour Factor	0.92	0.92	0.92	0.92	0.92	0.92	0.92	0.92	0.92	0.92	0.92	0.92
Percent Heavy Veh, %	2	2	2	2	2	2	2	2	2	2	2	2
Cap, veh/h	117	74	73	99	145	29	88	2114	946	31	2000	895
Arrive On Green	0.11	0.11	0.11	0.11	0.11	0.11	0.05	0.60	0.00	0.02	0.57	0.00
Sat Flow, veh/h	250	703	693	135	1375	274	1774	3539	1583	1774	3539	1583
Grp Volume(v), veh/h	114	0	0	52	0	0	49	290	0	14	576	0
Grp Sat Flow(s),veh/h/in	1647	0	0	1784	0	0	1774	1770	1583	1774	1770	1583
Q Serve(g_s), s	1.8	0.0	0.0	0.0	0.0	0.0	1.3	1.7	0.0	0.4	4.1	0.0
Cycle Q Clear(g_c), s	3.2	0.0	0.0	1.3	0.0	0.0	1.3	1.7	0.0	0.4	4.1	0.0
Prop In Lane	0.21		0.42	0.13		0.15	1.00		1.00	1.00		1.00
Lane Grp Cap(c), veh/h	264	0	0	273	0	0	88	2114	946	31	2000	895
V/C Ratio(X)	0.43	0.00	0.00	0.19	0.00	0.00	0.55	0.14	0.00	0.45	0.29	0.00
Avail Cap(c_a), veh/h	966	0	0	1019	0	0	481	2114	946	481	2000	895
HCM Platoon Ratio	1.00	1.00	1.00	1.00	1.00	1.00	1.00	1.00	1.00	1.00	1.00	1.00
Upstream Filter(I)	1.00	0.00	0.00	1.00	0.00	0.00	1.00	1.00	0.00	1.00	1.00	0.00
Uniform Delay (d), s/veh	20.7	0.0	0.0	19.9	0.0	0.0	22.4	4.3	0.0	23.5	5.5	0.0
Incr Delay (d2), s/veh	1.1	0.0	0.0	0.3	0.0	0.0	5.3	0.1	0.0	9.8	0.4	0.0
Initial Q Delay(d3),s/veh	0.0	0.0	0.0	0.0	0.0	0.0	0.0	0.0	0.0	0.0	0.0	0.0
%ile BackOfQ(50%),veh/ln	5	0.0	0.0	0.7	0.0	0.0	0.8	0.9	0.0	0.3	2.1	0.0
LnGrp Delay(d),s/veh	21.8	0.0	0.0	20.2	0.0	0.0	27.7	4.4	0.0	33.1	5.8	0.0
LnGrp LOS	C			C			C	A		C	A	
Approach Vol, veh/h		114			52			339			590	
Approach Delay, s/veh		21.8			20.2			7.8			6.5	
Approach LOS		C			C			A			A	
Timer	1	2	3	4	5	6	7	8				
Assigned Phs	1	2		4	5	6		8				
Phs Duration (G+Y+Rc), s	5.4	33.4		9.6	6.9	31.8		9.6				
Change Period (Y+Rc), s	4.5	4.5		4.5	4.5	4.5		4.5				
Max Green Setting (Gmax), s	27.3			26.1	13.1	27.3		26.1				
Max Q Clear Time (g_c+I), s	3.7			5.2	3.3	6.1		3.3				
Green Ext Time (p_c), s	0.0	1.8		0.5	0.0	3.9		0.2				
Intersection Summary												
HCM 2010 Ctrl Delay					9.1							
HCM 2010 LOS					A							

HCM 2010 Signalized Intersection Summary
1: SR-86 & Keystone Road

Ex+Total Project AM
09/06/2018

	↖	→	↗	↖	←	↖	↗	↑	↖	↗	↓	↖
Movement	EBL	EBT	EBR	WBL	WBT	WBR	NBL	NBT	NBR	SBL	SBT	SBR
Lane Configurations		↕			↕		↖	↗	↖	↖	↗	↖
Traffic Volume (veh/h)	29	29	13	27	17	38	14	473	56	48	523	34
Future Volume (veh/h)	29	29	13	27	17	38	14	473	56	48	523	34
Number	7	4	14	3	8	18	5	2	12	1	6	16
Initial Q (Qb), veh	0	0	0	0	0	0	0	0	0	0	0	0
Ped-Bike Adj(A_pbT)	1.00		1.00	1.00		1.00	1.00		1.00	1.00		1.00
Parking Bus, Adj	1.00	1.00	1.00	1.00	1.00	1.00	1.00	1.00	1.00	1.00	1.00	1.00
Adj Sat Flow, veh/h/ln	1900	1863	1900	1900	1863	1900	1863	1863	1863	1863	1863	1863
Adj Flow Rate, veh/h	32	32	14	29	18	41	15	514	61	52	568	37
Adj No. of Lanes	0	1	0	0	1	0	1	2	1	1	2	1
Peak Hour Factor	0.92	0.92	0.92	0.92	0.92	0.92	0.92	0.92	0.92	0.92	0.92	0.92
Percent Heavy Veh, %	2	2	2	2	2	2	2	2	2	2	2	2
Cap, veh/h	141	70	26	124	38	66	33	2209	988	88	2319	1037
Arrive On Green	0.09	0.09	0.09	0.09	0.09	0.09	0.02	0.62	0.62	0.05	0.66	0.66
Sat Flow, veh/h	584	817	307	448	440	775	1774	3539	1583	1774	3539	1583
Grp Volume(v), veh/h	78	0	0	88	0	0	15	514	61	52	568	37
Grp Sat Flow(s),veh/h/ln	1708	0	0	1863	0	0	1774	1770	1583	1774	1770	1583
Q Serve(g_s), s	0.0	0.0	0.0	0.4	0.0	0.0	0.5	3.6	0.8	1.6	3.7	0.5
Cycle Q Clear(g_c), s	2.3	0.0	0.0	2.7	0.0	0.0	0.5	3.6	0.8	1.6	3.7	0.5
Prop In Lane	0.41		0.18	0.33		0.47	1.00		1.00	1.00		1.00
Lane Grp Cap(c), veh/h	237	0	0	228	0	0	33	2209	988	88	2319	1037
V/C Ratio(X)	0.33	0.00	0.00	0.39	0.00	0.00	0.46	0.23	0.06	0.59	0.24	0.04
Avail Cap(c_a), veh/h	1106	0	0	1087	0	0	158	2209	988	158	2319	1037
HCM Platoon Ratio	1.00	1.00	1.00	1.00	1.00	1.00	1.00	1.00	1.00	1.00	1.00	1.00
Upstream Filter(I)	1.00	0.00	0.00	1.00	0.00	0.00	1.00	1.00	1.00	1.00	1.00	1.00
Uniform Delay (d), s/veh	24.5	0.0	0.0	24.7	0.0	0.0	27.2	4.6	4.1	26.1	4.0	3.4
Incr Delay (d2), s/veh	0.8	0.0	0.0	1.1	0.0	0.0	9.5	0.2	0.1	6.2	0.3	0.1
Initial Q Delay(d3),s/veh	0.0	0.0	0.0	0.0	0.0	0.0	0.0	0.0	0.0	0.0	0.0	0.0
%ile BackOfQ(50%),veh/ln	1.2	0.0	0.0	1.4	0.0	0.0	0.3	1.8	0.4	0.9	1.8	0.2
LnGrp Delay(d),s/veh	25.3	0.0	0.0	25.7	0.0	0.0	36.7	4.9	4.2	32.3	4.2	3.5
LnGrp LOS	C			C			D	A	A	C	A	A
Approach Vol, veh/h		78			88			590			657	
Approach Delay, s/veh		25.3			25.7			5.6			6.4	
Approach LOS		C			C			A			A	
Timer	1	2	3	4	5	6	7	8				
Assigned Phs	1	2		4	5	6		8				
Phs Duration (G+Y+Rc), s	7.3	39.5		9.3	5.5	41.2		9.3				
Change Period (Y+Rc), s	4.5	4.5		4.5	4.5	4.5		4.5				
Max Green Setting (Gmax), s	5.0	35.0		36.0	5.0	35.0		36.0				
Max Q Clear Time (g_c+1), s	3.6	5.6		4.3	2.5	5.7		4.7				
Green Ext Time (p_c), s	0.0	3.9		0.4	0.0	4.3		0.5				
Intersection Summary												
HCM 2010 Ctrl Delay				8.3								
HCM 2010 LOS				A								

HCM 2010 Signalized Intersection Summary
 2: SR-111 & Keystone Road

Ex+Total Project AM
 09/06/2018

	↖	→	↗	↖	←	↗	↖	↑	↗	↘	↓	↖
Movement	EBL	EBT	EBR	WBL	WBT	WBR	NBL	NBT	NBR	SBL	SBT	SBR
Lane Configurations		↔			↔		↖	↗	↖	↗	↗	↖
Traffic Volume (veh/h)	12	12	33	2	7	2	46	436	3	1	551	6
Future Volume (veh/h)	12	12	33	2	7	2	46	436	3	1	551	6
Number	7	4	14	3	8	18	5	2	12	1	6	16
Initial Q (Qb), veh	0	0	0	0	0	0	0	0	0	0	0	0
Ped-Bike Adj(A_pbT)	1.00		1.00	1.00		1.00	1.00		1.00	1.00		1.00
Parking Bus, Adj	1.00	1.00	1.00	1.00	1.00	1.00	1.00	1.00	1.00	1.00	1.00	1.00
Adj Sat Flow, veh/h/ln	1900	1863	1900	1900	1863	1900	1863	1863	1863	1863	1863	1863
Adj Flow Rate, veh/h	13	13	36	2	8	2	50	474	3	1	599	7
Adj No. of Lanes	0	1	0	0	1	0	1	2	1	1	2	1
Peak Hour Factor	0.92	0.92	0.92	0.92	0.92	0.92	0.92	0.92	0.92	0.92	0.92	0.92
Percent Heavy Veh, %	2	2	2	2	2	2	2	2	2	2	2	2
Cap, veh/h	114	25	62	105	84	20	91	2266	1014	4	2090	935
Arrive On Green	0.07	0.07	0.07	0.07	0.07	0.07	0.05	0.64	0.64	0.00	0.59	0.59
Sat Flow, veh/h	298	372	929	216	1264	296	1774	3539	1583	1774	3539	1583
Grp Volume(v), veh/h	62	0	0	12	0	0	50	474	3	1	599	7
Grp Sat Flow(s),veh/h/ln1600	0	0	0	1775	0	0	1774	1770	1583	1774	1770	1583
Q Serve(g_s), s	1.4	0.0	0.0	0.0	0.0	0.0	1.3	2.6	0.0	0.0	3.9	0.1
Cycle Q Clear(g_c), s	1.7	0.0	0.0	0.3	0.0	0.0	1.3	2.6	0.0	0.0	3.9	0.1
Prop In Lane	0.21		0.58	0.17		0.17	1.00		1.00	1.00		1.00
Lane Grp Cap(c), veh/h	200	0	0	209	0	0	91	2266	1014	4	2090	935
V/C Ratio(X)	0.31	0.00	0.00	0.06	0.00	0.00	0.55	0.21	0.00	0.26	0.29	0.01
Avail Cap(c_a), veh/h	992	0	0	1058	0	0	503	2266	1014	503	2090	935
HCM Platoon Ratio	1.00	1.00	1.00	1.00	1.00	1.00	1.00	1.00	1.00	1.00	1.00	1.00
Upstream Filter(I)	1.00	0.00	0.00	1.00	0.00	0.00	1.00	1.00	1.00	1.00	1.00	1.00
Uniform Delay (d), s/veh	21.0	0.0	0.0	20.3	0.0	0.0	21.4	3.5	3.0	23.0	4.7	3.9
Incr Delay (d2), s/veh	0.9	0.0	0.0	0.1	0.0	0.0	5.1	0.2	0.0	32.5	0.3	0.0
Initial Q Delay(d3),s/veh	0.0	0.0	0.0	0.0	0.0	0.0	0.0	0.0	0.0	0.0	0.0	0.0
%ile BackOfQ(50%),veh/ln0.8	0.0	0.0	0.0	0.1	0.0	0.0	0.8	1.3	0.0	0.0	1.9	0.0
LnGrp Delay(d),s/veh	21.8	0.0	0.0	20.4	0.0	0.0	26.5	3.7	3.0	55.6	5.0	3.9
LnGrp LOS	C			C			C	A	A	E	A	A
Approach Vol, veh/h		62			12			527			607	
Approach Delay, s/veh		21.8			20.4			5.8			5.1	
Approach LOS		C			C			A			A	
Timer	1	2	3	4	5	6	7	8				
Assigned Phs	1	2		4	5	6		8				
Phs Duration (G+Y+Rc), s	4.6	34.1		7.6	6.9	31.8		7.6				
Change Period (Y+Rc), s	4.5	4.5		4.5	4.5	4.5		4.5				
Max Green Setting (Gmax), s	27.3			26.1	13.1	27.3		26.1				
Max Q Clear Time (g_c+I), s	4.6			3.7	3.3	5.9		2.3				
Green Ext Time (p_c), s	0.0	3.2		0.3	0.1	4.1		0.0				
Intersection Summary												
HCM 2010 Ctrl Delay					6.4							
HCM 2010 LOS					A							

Intersection												
Int Delay, s/veh	0.3											
Movement	EBL	EBT	EBR	WBL	WBT	WBR	NBL	NBT	NBR	SBL	SBT	SBR
Lane Configurations		↔			↔			↔			↔	
Traffic Vol, veh/h	0	0	0	3	2	15	1	539	11	9	547	1
Future Vol, veh/h	0	0	0	3	2	15	1	539	11	9	547	1
Conflicting Peds, #/hr	0	0	0	0	0	0	0	0	0	0	0	0
Sign Control	Stop	Stop	Stop	Stop	Stop	Stop	Free	Free	Free	Free	Free	Free
RT Channelized	-	-	None	-	-	None	-	-	None	-	-	None
Storage Length	-	-	-	-	-	-	-	-	-	-	-	-
Veh In Median Storage, #	-	-	-	-	0	-	-	0	-	-	0	-
Grade, %	-	0	-	-	0	-	-	0	-	-	0	-
Peak Hour Factor	92	92	92	92	92	92	92	92	92	92	92	92
Heavy Vehicles, %	2	2	2	2	2	2	2	2	2	2	2	2
Mvmt Flow	0	0	0	3	2	16	1	586	12	10	595	1

Major/Minor	Minor2		Minor1		Major1		Major2					
Conflicting Flow All	912	1216	298	912	1210	299	596	0	0	598	0	0
Stage 1	616	616	-	594	594	-	-	-	-	-	-	-
Stage 2	296	600	-	318	616	-	-	-	-	-	-	-
Critical Hdwy	7.54	6.54	6.94	7.54	6.54	6.94	4.14	-	-	4.14	-	-
Critical Hdwy Stg 1	6.54	5.54	-	6.54	5.54	-	-	-	-	-	-	-
Critical Hdwy Stg 2	6.54	5.54	-	6.54	5.54	-	-	-	-	-	-	-
Follow-up Hdwy	3.52	4.02	3.32	3.52	4.02	3.32	2.22	-	-	2.22	-	-
Pot Cap-1 Maneuver	229	180	698	229	181	697	976	-	-	975	-	-
Stage 1	445	480	-	458	491	-	-	-	-	-	-	-
Stage 2	668	488	-	668	480	-	-	-	-	-	-	-
Platoon blocked, %	-	-	-	-	-	-	-	-	-	-	-	-
Mov Cap-1 Maneuver	219	177	698	226	178	697	976	-	-	975	-	-
Mov Cap-2 Maneuver	219	177	-	226	178	-	-	-	-	-	-	-
Stage 1	444	473	-	457	490	-	-	-	-	-	-	-
Stage 2	668	487	-	658	473	-	-	-	-	-	-	-

Approach	EB	WB	NB	SB
HCM Control Delay, s	0	13.7	0	0.2
HCM LOS	A	B		

Minor Lane/Major Mvmt	NBL	NBT	NBR	EBLn1	WBLn1	SBL	SBT	SBR
Capacity (veh/h)	976	-	-	-	434	975	-	-
HCM Lane V/C Ratio	0.001	-	-	-	0.05	0.01	-	-
HCM Control Delay (s)	8.7	0	-	0	13.7	8.7	0.1	-
HCM Lane LOS	A	A	-	A	B	A	A	-
HCM 95th %ile Q(veh)	0	-	-	-	0.2	0	-	-

HCM 2010 Signalized Intersection Summary
4: Harris Road & Dogwood Rd

Ex+Total Project AM
09/06/2018

	↖	→	↗	↖	←	↗	↖	↑	↗	↘	↓	↖
Movement	EBL	EBT	EBR	WBL	WBT	WBR	NBL	NBT	NBR	SBL	SBT	SBR
Lane Configurations		↕			↕			↕			↕	
Traffic Volume (veh/h)	2	2	5	2	24	4	1	100	2	2	180	6
Future Volume (veh/h)	2	2	5	2	24	4	1	100	2	2	180	6
Number	7	4	14	3	8	18	5	2	12	1	6	16
Initial Q (Qb), veh	0	0	0	0	0	0	0	0	0	0	0	0
Ped-Bike Adj(A_pbT)	1.00		1.00	1.00		1.00	1.00		1.00	1.00		1.00
Parking Bus, Adj	1.00	1.00	1.00	1.00	1.00	1.00	1.00	1.00	1.00	1.00	1.00	1.00
Adj Sat Flow, veh/h/ln	1900	1863	1900	1900	1863	1900	1900	1863	1900	1900	1863	1900
Adj Flow Rate, veh/h	2	2	5	2	26	4	1	109	2	2	174	7
Adj No. of Lanes	0	1	0	0	1	0	0	1	0	0	1	0
Peak Hour Factor	0.92	0.92	0.92	0.92	0.92	0.92	0.92	0.92	0.92	0.92	0.92	0.92
Percent Heavy Veh, %	2	2	2	2	2	2	2	2	2	2	2	2
Cap, veh/h	189	197	360	97	823	91	82	728	13	82	710	28
Arrive On Green	0.40	0.40	0.40	0.40	0.40	0.40	0.40	0.40	0.40	0.40	0.40	0.40
Sat Flow, veh/h	229	492	901	30	1557	227	3	1820	33	4	1774	71
Grp Volume(v), veh/h	9	0	0	32	0	0	112	0	0	183	0	0
Grp Sat Flow(s), veh/h/ln	1822	0	0	1813	0	0	1855	0	0	1848	0	0
Q Serve(g_s), s	0.0	0.0	0.0	0.0	0.0	0.0	0.0	0.0	0.0	0.0	0.0	0.0
Cycle Q Clear(g_c), s	0.1	0.0	0.0	0.5	0.0	0.0	1.7	0.0	0.0	3.0	0.0	0.0
Prop In Lane	0.22		0.56	0.08		0.12	0.01		0.02	0.01		0.04
Lane Grp Cap(c), veh/h	747	0	0	810	0	0	823	0	0	820	0	0
V/C Ratio(X)	0.01	0.00	0.00	0.04	0.00	0.00	0.14	0.00	0.00	0.22	0.00	0.00
Avail Cap(c_a), veh/h	747	0	0	810	0	0	823	0	0	820	0	0
HCM Platoon Ratio	1.00	1.00	1.00	1.00	1.00	1.00	1.00	1.00	1.00	1.00	1.00	1.00
Upstream Filter(I)	1.00	0.00	0.00	1.00	0.00	0.00	1.00	0.00	0.00	1.00	0.00	0.00
Uniform Delay (d), s/veh	8.1	0.0	0.0	8.2	0.0	0.0	8.6	0.0	0.0	9.0	0.0	0.0
Incr Delay (d2), s/veh	0.0	0.0	0.0	0.1	0.0	0.0	0.3	0.0	0.0	0.6	0.0	0.0
Initial Q Delay(d3),s/veh	0.0	0.0	0.0	0.0	0.0	0.0	0.0	0.0	0.0	0.0	0.0	0.0
%ile BackOfQ(50%),veh/ln	0.1	0.0	0.0	0.3	0.0	0.0	0.9	0.0	0.0	1.6	0.0	0.0
LnGrp Delay(d),s/veh	8.2	0.0	0.0	8.3	0.0	0.0	9.0	0.0	0.0	9.6	0.0	0.0
LnGrp LOS	A			A			A			A		
Approach Vol, veh/h		9			32			112			183	
Approach Delay, s/veh		8.2			8.3			9.0			9.6	
Approach LOS		A			A			A			A	
Timer	1	2	3	4	5	6	7	8				
Assigned Phs		2		4		6		8				
Phs Duration (G+Y+Rc), s		22.5		22.5		22.5		22.5				
Change Period (Y+Rc), s		4.5		4.5		4.5		4.5				
Max Green Setting (Gmax), s		18.0		18.0		18.0		18.0				
Max Q Clear Time (g_cp+1), s		3.7		2.1		5.0		2.5				
Green Ext Time (p_c), s		0.4		0.0		0.7		0.1				
Intersection Summary												
HCM 2010 Ctrl Delay				9.2								
HCM 2010 LOS				A								

HCM 2010 Signalized Intersection Summary
5: SR-111 & Harris Road

Ex+Total Project AM
09/06/2018

Movement	EBL	EBT	EBR	WBL	WBT	WBR	NBL	NBT	NBR	SBL	SBT	SBR
Lane Configurations		⇄			⇄		↖	↗	↖	↗	↖	↗
Traffic Volume (veh/h)	7	8	4	2	8	0	24	471	0	1	566	6
Future Volume (veh/h)	7	8	4	2	8	0	24	471	0	1	566	6
Number	7	4	14	3	8	18	5	2	12	1	6	16
Initial Q (Qb), veh	0	0	0	0	0	0	0	0	0	0	0	0
Ped-Bike Adj(A_pbT)	1.00		1.00	1.00		1.00	1.00		1.00	1.00		1.00
Parking Bus, Adj	1.00	1.00	1.00	1.00	1.00	1.00	1.00	1.00	1.00	1.00	1.00	1.00
Adj Sat Flow, veh/h/ln	1900	1863	1900	1900	1863	1900	1863	1863	1863	1863	1863	1863
Adj Flow Rate, veh/h	8	9	4	2	9	0	26	512	0	1	615	7
Adj No. of Lanes	0	1	0	0	1	0	1	2	1	1	2	1
Peak Hour Factor	0.92	0.92	0.92	0.92	0.92	0.92	0.92	0.92	0.92	0.92	0.92	0.92
Percent Heavy Veh, %	2	2	2	2	2	2	2	2	2	2	2	2
Cap, veh/h	118	25	11	94	52	0	53	2488	1113	3	2386	1068
Arrive On Green	0.04	0.04	0.04	0.04	0.04	0.00	0.03	0.70	0.00	0.00	0.67	0.67
Sat Flow, veh/h	626	704	313	325	1461	0	1774	3539	1583	1774	3539	1583
Grp Volume(v), veh/h	21	0	0	11	0	0	26	512	0	1	615	7
Grp Sat Flow(s), veh/h/ln	1643	0	0	1786	0	0	1774	1770	1583	1774	1770	1583
Q Serve(g_s), s	0.3	0.0	0.0	0.0	0.0	0.0	0.7	2.6	0.0	0.0	3.6	0.1
Cycle Q Clear(g_c), s	0.6	0.0	0.0	0.3	0.0	0.0	0.7	2.6	0.0	0.0	3.6	0.1
Prop In Lane	0.38		0.19	0.18		0.00	1.00		1.00	1.00		1.00
Lane Grp Cap(c), veh/h	154	0	0	146	0	0	53	2488	1113	3	2386	1068
V/C Ratio(X)	0.14	0.00	0.00	0.08	0.00	0.00	0.49	0.21	0.00	0.29	0.28	0.01
Avail Cap(c_a), veh/h	1211	0	0	1301	0	0	171	2488	1113	171	2386	1068
HCM Platoon Ratio	1.00	1.00	1.00	1.00	1.00	1.00	1.00	1.00	1.00	1.00	1.00	1.00
Upstream Filter(I)	1.00	0.00	0.00	1.00	0.00	0.00	1.00	1.00	0.00	1.00	1.00	1.00
Uniform Delay (d), s/veh	24.4	0.0	0.0	24.3	0.0	0.0	24.8	2.7	0.0	25.9	3.3	2.8
Incr Delay (d2), s/veh	0.4	0.0	0.0	0.2	0.0	0.0	6.7	0.2	0.0	41.6	0.3	0.0
Initial Q Delay(d3), s/veh	0.0	0.0	0.0	0.0	0.0	0.0	0.0	0.0	0.0	0.0	0.0	0.0
%ile BackOfQ(50%), veh/ln	0.3	0.0	0.0	0.2	0.0	0.0	0.5	1.3	0.0	0.1	1.8	0.0
LnGrp Delay(d), s/veh	24.8	0.0	0.0	24.5	0.0	0.0	31.5	2.9	0.0	67.5	3.6	2.8
LnGrp LOS	C			C			C	A		E	A	A
Approach Vol, veh/h		21			11			538			623	
Approach Delay, s/veh		24.8			24.5			4.2			3.7	
Approach LOS		C			C			A			A	
Timer	1	2	3	4	5	6	7	8				
Assigned Phs	1	2		4	5	6		8				
Phs Duration (G+Y+Rc), s	41.0			6.3	6.1	39.5		6.3				
Change Period (Y+Rc), s	4.5	4.5		4.5	4.5	4.5		4.5				
Max Green Setting (Gmax), s	35.0			36.0	5.0	35.0		36.0				
Max Q Clear Time (g_c+I), s	4.6			2.6	2.7	5.6		2.3				
Green Ext Time (p_c), s	0.0	3.7		0.1	0.0	4.6		0.0				
Intersection Summary												
HCM 2010 Ctrl Delay				4.5								
HCM 2010 LOS				A								

HCM 2010 Signalized Intersection Summary
6: SR-86 & Worthington Road

Ex+Total Project AM
09/06/2018

Movement	EBL	EBT	EBR	WBL	WBT	WBR	NBL	NBT	NBR	SBL	SBT	SBR
Lane Configurations		↖	↗		↖	↗	↖	↗		↖	↗	
Traffic Volume (veh/h)	67	152	164	67	120	82	103	519	57	46	806	78
Future Volume (veh/h)	67	152	164	67	120	82	103	519	57	46	806	78
Number	7	4	14	3	8	18	5	2	12	1	6	16
Initial Q (Qb), veh	0	0	0	0	0	0	0	0	0	0	0	0
Ped-Bike Adj(A_pbT)	1.00		1.00	1.00		1.00	1.00		1.00	1.00		1.00
Parking Bus, Adj	1.00	1.00	1.00	1.00	1.00	1.00	1.00	1.00	1.00	1.00	1.00	1.00
Adj Sat Flow, veh/h/ln	1900	1863	1863	1900	1863	1863	1863	1863	1900	1863	1863	1900
Adj Flow Rate, veh/h	73	165	178	73	130	89	112	564	62	50	876	85
Adj No. of Lanes	0	1	1	0	1	1	1	2	0	1	2	0
Peak Hour Factor	0.92	0.92	0.92	0.92	0.92	0.92	0.92	0.92	0.92	0.92	0.92	0.92
Percent Heavy Veh, %	2	2	2	2	2	2	2	2	2	2	2	2
Cap, veh/h	90	204	254	92	164	222	142	1436	157	72	1326	129
Arrive On Green	0.16	0.16	0.16	0.14	0.14	0.14	0.08	0.45	0.45	0.04	0.41	0.41
Sat Flow, veh/h	563	1272	1583	658	1172	1583	1774	3217	353	1774	3260	316
Grp Volume(v), veh/h	238	0	178	203	0	89	112	310	316	50	475	486
Grp Sat Flow(s), veh/h/ln	1835	0	1583	1830	0	1583	1774	1770	1800	1774	1770	1807
Q Serve(g_s), s	10.6	0.0	9.0	9.1	0.0	4.3	5.3	10.0	10.0	2.4	18.5	18.5
Cycle Q Clear(g_c), s	10.6	0.0	9.0	9.1	0.0	4.3	5.3	10.0	10.0	2.4	18.5	18.5
Prop In Lane	0.31		1.00	0.36		1.00	1.00		0.20	1.00		0.18
Lane Grp Cap(c), veh/h	295	0	254	257	0	222	142	790	804	72	720	735
V/C Ratio(X)	0.81	0.00	0.70	0.79	0.00	0.40	0.79	0.39	0.39	0.69	0.66	0.66
Avail Cap(c_a), veh/h	400	0	345	399	0	345	219	790	804	148	720	735
HCM Platoon Ratio	1.00	1.00	1.00	1.00	1.00	1.00	1.00	1.00	1.00	1.00	1.00	1.00
Upstream Filter(I)	1.00	0.00	1.00	1.00	0.00	1.00	1.00	1.00	1.00	1.00	1.00	1.00
Uniform Delay (d), s/veh	34.4	0.0	33.7	35.3	0.0	33.3	38.3	15.8	15.8	40.2	20.4	20.4
Incr Delay (d2), s/veh	8.5	0.0	3.9	5.8	0.0	1.2	9.9	1.5	1.4	11.1	4.7	4.6
Initial Q Delay(d3), s/veh	0.0	0.0	0.0	0.0	0.0	0.0	0.0	0.0	0.0	0.0	0.0	0.0
%ile BackOfQ(50%),veh/ln	6.1	0.0	4.2	5.0	0.0	2.0	3.0	5.1	5.2	1.4	9.9	10.1
LnGrp Delay(d),s/veh	42.9	0.0	37.6	41.0	0.0	34.4	48.2	17.2	17.2	51.3	25.1	25.1
LnGrp LOS	D		D	D		C	D	B	B	D	C	C
Approach Vol, veh/h		416			292			738			1011	
Approach Delay, s/veh		40.6			39.0			21.9			26.4	
Approach LOS		D			D			C			C	
Timer	1	2	3	4	5	6	7	8				
Assigned Phs	1	2		4	5	6		8				
Phs Duration (G+Y+Rc), s	0.0	42.4		18.1	11.3	39.1		16.4				
Change Period (Y+Rc), s	4.5	4.5		4.5	4.5	4.5		4.5				
Max Green Setting (Gmax), s	37.9			18.5	10.5	34.5		18.5				
Max Q Clear Time (g_c+1/4), s	12.0			12.6	7.3	20.5		11.1				
Green Ext Time (p_c), s	0.0	4.1		1.0	0.1	5.4		0.8				
Intersection Summary												
HCM 2010 Ctrl Delay				29.0								
HCM 2010 LOS				C								

HCM 2010 Signalized Intersection Summary
7: SR-111 & Worthington Rd

Ex+Total Project AM
09/06/2018

Movement	EBL	EBT	EBR	WBL	WBT	WBR	NBL	NBT	NBR	SBL	SBT	SBR
Lane Configurations		↔			↔		↖	↗	↖	↗	↖	↗
Traffic Volume (veh/h)	27	50	98	4	69	15	75	442	2	4	447	132
Future Volume (veh/h)	27	50	98	4	69	15	75	442	2	4	447	132
Number	7	4	14	3	8	18	5	2	12	1	6	16
Initial Q (Qb), veh	0	0	0	0	0	0	0	0	0	0	0	0
Ped-Bike Adj(A_pbT)	1.00		1.00	1.00		1.00	1.00		1.00	1.00		1.00
Parking Bus, Adj	1.00	1.00	1.00	1.00	1.00	1.00	1.00	1.00	1.00	1.00	1.00	1.00
Adj Sat Flow, veh/h/in	1900	1863	1900	1900	1863	1900	1863	1863	1863	1863	1863	1863
Adj Flow Rate, veh/h	29	54	107	4	75	16	82	480	0	4	486	0
Adj No. of Lanes	0	1	0	0	1	0	1	2	1	1	2	1
Peak Hour Factor	0.92	0.92	0.92	0.92	0.92	0.92	0.92	0.92	0.92	0.92	0.92	0.92
Percent Heavy Veh, %	2	2	2	2	2	2	2	2	2	2	2	2
Cap, veh/h	103	91	150	75	239	49	117	2040	913	10	1825	817
Arrive On Green	0.16	0.16	0.16	0.16	0.16	0.16	0.07	0.58	0.00	0.01	0.52	0.00
Sat Flow, veh/h	153	561	920	27	1468	303	1774	3539	1583	1774	3539	1583
Grp Volume(v), veh/h	190	0	0	95	0	0	82	480	0	4	486	0
Grp Sat Flow(s),veh/h/in	1634	0	0	1798	0	0	1774	1770	1583	1774	1770	1583
Q Serve(g_s), s	2.5	0.0	0.0	0.0	0.0	0.0	2.4	3.5	0.0	0.1	4.1	0.0
Cycle Q Clear(g_c), s	5.8	0.0	0.0	2.5	0.0	0.0	2.4	3.5	0.0	0.1	4.1	0.0
Prop In Lane	0.15		0.56	0.04		0.17	1.00		1.00	1.00		1.00
Lane Grp Cap(c), veh/h	345	0	0	364	0	0	117	2040	913	10	1825	817
V/C Ratio(X)	0.55	0.00	0.00	0.26	0.00	0.00	0.70	0.24	0.00	0.42	0.27	0.00
Avail Cap(c_a), veh/h	872	0	0	948	0	0	439	2040	913	439	1825	817
HCM Platoon Ratio	1.00	1.00	1.00	1.00	1.00	1.00	1.00	1.00	1.00	1.00	1.00	1.00
Upstream Filter(I)	1.00	0.00	0.00	1.00	0.00	0.00	1.00	1.00	0.00	1.00	1.00	0.00
Uniform Delay (d), s/veh	20.9	0.0	0.0	19.6	0.0	0.0	24.2	5.5	0.0	26.2	7.2	0.0
Incr Delay (d2), s/veh	1.4	0.0	0.0	0.4	0.0	0.0	7.3	0.3	0.0	26.5	0.4	0.0
Initial Q Delay(d3),s/veh	0.0	0.0	0.0	0.0	0.0	0.0	0.0	0.0	0.0	0.0	0.0	0.0
%ile BackOfQ(50%),veh/ln	2.8	0.0	0.0	1.3	0.0	0.0	1.4	1.7	0.0	0.1	2.0	0.0
LnGrp Delay(d),s/veh	22.3	0.0	0.0	19.9	0.0	0.0	31.5	5.8	0.0	52.7	7.6	0.0
LnGrp LOS	C			B			C	A		D	A	
Approach Vol, veh/h	190		95				562			490		
Approach Delay, s/veh	22.3		19.9				9.5			7.9		
Approach LOS	C		B				A			A		
Timer	1	2	3	4	5	6	7	8				
Assigned Phs	1	2		4	5	6		8				
Phs Duration (G+Y+Rc), s	4.8	35.0		13.1	8.0	31.8		13.1				
Change Period (Y+Rc), s	4.5	4.5		4.5	4.5	4.5		4.5				
Max Green Setting (Gmax), s	27.3			26.1	13.1	27.3		26.1				
Max Q Clear Time (g_c+I), s	5.5			7.8	4.4	6.1		4.5				
Green Ext Time (p_c), s	0.0	3.2		1.0	0.1	3.2		0.4				
Intersection Summary												
HCM 2010 Ctrl Delay			11.5									
HCM 2010 LOS			B									

HCM 2010 Signalized Intersection Summary
 1: SR-86 & Keystone Road

Ex + Total Project PM
 09/10/2018

	↖	→	↘	↙	←	↖	↙	↑	↘	↙	↓	↘
Movement	EBL	EBT	EBR	WBL	WBT	WBR	NBL	NBT	NBR	SBL	SBT	SBR
Lane Configurations		↔			↔		↖	↖	↖	↖	↖	↖
Traffic Volume (veh/h)	31	13	20	19	22	39	17	578	18	42	565	15
Future Volume (veh/h)	31	13	20	19	22	39	17	578	18	42	565	15
Number	7	4	14	3	8	18	5	2	12	1	6	16
Initial Q (Qb), veh	0	0	0	0	0	0	0	0	0	0	0	0
Ped-Bike Adj(A_pbT)	1.00		1.00	1.00		1.00	1.00		1.00	1.00		1.00
Parking Bus, Adj	1.00	1.00	1.00	1.00	1.00	1.00	1.00	1.00	1.00	1.00	1.00	1.00
Adj Sat Flow, veh/h/ln	1900	1863	1900	1900	1863	1900	1863	1863	1863	1863	1863	1863
Adj Flow Rate, veh/h	34	14	22	21	24	42	18	628	20	46	614	16
Adj No. of Lanes	0	1	0	0	1	0	1	2	1	1	2	1
Peak Hour Factor	0.92	0.92	0.92	0.92	0.92	0.92	0.92	0.92	0.92	0.92	0.92	0.92
Percent Heavy Veh, %	2	2	2	2	2	2	2	2	2	2	2	2
Cap, veh/h	154	38	44	106	47	68	39	2221	994	81	2306	1032
Arrive On Green	0.08	0.08	0.08	0.08	0.08	0.08	0.02	0.63	0.63	0.05	0.65	0.65
Sat Flow, veh/h	693	453	525	308	556	806	1774	3539	1583	1774	3539	1583
Grp Volume(v), veh/h	70	0	0	87	0	0	18	628	20	48	614	16
Grp Sat Flow(s),veh/h/ln	1671	0	0	1670	0	0	1774	1770	1583	1774	1770	1583
Q Serve(g_s), s	0.0	0.0	0.0	0.6	0.0	0.0	0.6	4.5	0.3	1.4	4.1	0.2
Cycle Q Clear(g_c), s	2.1	0.0	0.0	2.7	0.0	0.0	0.6	4.5	0.3	1.4	4.1	0.2
Prop In Lane	0.49		0.31	0.24		0.48	1.00		1.00	1.00		1.00
Lane Grp Cap(c), veh/h	237	0	0	221	0	0	39	2221	994	81	2306	1032
V/C Ratio(X)	0.30	0.00	0.00	0.39	0.00	0.00	0.47	0.28	0.02	0.57	0.27	0.02
Avail Cap(c_a), veh/h	1073	0	0	1112	0	0	159	2221	994	159	2306	1032
HCM Platoon Ratio	1.00	1.00	1.00	1.00	1.00	1.00	1.00	1.00	1.00	1.00	1.00	1.00
Upstream Filter(I)	1.00	0.00	0.00	1.00	0.00	0.00	1.00	1.00	1.00	1.00	1.00	1.00
Uniform Delay (d), s/veh	24.3	0.0	0.0	24.6	0.0	0.0	27.0	4.7	3.9	26.1	4.1	3.4
Incr Delay (d2), s/veh	0.7	0.0	0.0	1.1	0.0	0.0	8.4	0.3	0.0	6.1	0.3	0.0
Initial Q Delay(d3),s/veh	0.0	0.0	0.0	0.0	0.0	0.0	0.0	0.0	0.0	0.0	0.0	0.0
%ile BackOfQ(50%),veh/ln	1.1	0.0	0.0	1.4	0.0	0.0	0.4	2.3	0.1	0.8	2.1	0.1
LnGrp Delay(d),s/veh	25.0	0.0	0.0	25.7	0.0	0.0	35.4	5.0	4.0	32.2	4.4	3.4
LnGrp LOS	C			C			D	A	A	C	A	A
Approach Vol, veh/h		70			87			666			676	
Approach Delay, s/veh		25.0			25.7			5.8			6.2	
Approach LOS		C			C			A			A	
Timer	1	2	3	4	5	6	7	8				
Assigned Phs	1	2		4	5	6		8				
Phs Duration (G+Y+Rc), s	7.0	39.5		9.2	5.7	40.8		9.2				
Change Period (Y+Rc), s	4.5	4.5		4.5	4.5	4.5		4.5				
Max Green Setting (Gmax), s	5.0	35.0		36.0	5.0	35.0		36.0				
Max Q Clear Time (g_c+I1), s	3.4	6.5		4.1	2.6	6.1		4.7				
Green Ext Time (p_c), s	0.0	4.8		0.4	0.0	4.6		0.5				
Intersection Summary												
HCM 2010 Ctrl Delay				8.1								
HCM 2010 LOS				A								

HCM 2010 Signalized Intersection Summary
 2: SR-111 & Keystone Road

Ex + Total Project PM
 09/10/2018

Movement	EBL	EBT	EBR	WBL	WBT	WBR	NBL	NBT	NBR	SBL	SBT	SBR
Lane Configurations		↔			↔		↔	↑↑	↔	↔	↑↑	↔
Traffic Volume (veh/h)	6	7	54	2	8	0	24	352	2	4	634	3
Future Volume (veh/h)	6	7	54	2	8	0	24	352	2	4	634	3
Number	7	4	14	3	8	18	5	2	12	1	6	16
Initial Q (Qb), veh	0	0	0	0	0	0	0	0	0	0	0	0
Ped-Bike Adj(A_pbT)	1.00		1.00	1.00		1.00	1.00		1.00	1.00		1.00
Parking Bus, Adj	1.00	1.00	1.00	1.00	1.00	1.00	1.00	1.00	1.00	1.00	1.00	1.00
Adj Sat Flow, veh/h/in	1900	1863	1900	1900	1863	1900	1863	1863	1863	1863	1863	1863
Adj Flow Rate, veh/h	7	8	59	2	9	0	26	383	2	4	689	3
Adj No. of Lanes	0	1	0	0	1	0	1	2	1	1	2	1
Peak Hour Factor	0.92	0.92	0.92	0.92	0.92	0.92	0.92	0.92	0.92	0.92	0.92	0.92
Percent Heavy Veh. %	2	2	2	2	2	2	2	2	2	2	2	2
Cap, veh/h	95	15	92	110	115	0	55	2214	990	10	2124	950
Arrive On Green	0.07	0.07	0.07	0.07	0.07	0.00	0.03	0.63	0.63	0.01	0.60	0.60
Sat Flow, veh/h	117	207	1275	224	1586	0	1774	3539	1583	1774	3539	1583
Grp Volume(v), veh/h	74	0	0	11	0	0	26	383	2	4	689	3
Grp Sat Flow(s),veh/h/in	1599	0	0	1809	0	0	1774	1770	1583	1774	1770	1583
Q Serve(g_s), s	1.3	0.0	0.0	0.0	0.0	0.0	0.7	2.1	0.0	0.1	4.4	0.0
Cycle Q Clear(g_c), s	2.0	0.0	0.0	0.3	0.0	0.0	0.7	2.1	0.0	0.1	4.4	0.0
Prop in Lane	0.09		0.80	0.18		0.00	1.00		1.00	1.00		1.00
Lane Grp Cap(c), veh/h	202	0	0	224	0	0	55	2214	990	10	2124	950
V/C Ratio(X)	0.37	0.00	0.00	0.05	0.00	0.00	0.48	0.17	0.00	0.42	0.32	0.00
Avail Cap(c_a), veh/h	999	0	0	1095	0	0	511	2214	990	511	2124	950
HCM Platoon Ratio	1.00	1.00	1.00	1.00	1.00	1.00	1.00	1.00	1.00	1.00	1.00	1.00
Upstream Filter(I)	1.00	0.00	0.00	1.00	0.00	0.00	1.00	1.00	1.00	1.00	1.00	1.00
Uniform Delay (d), s/veh	20.5	0.0	0.0	19.7	0.0	0.0	21.7	3.6	3.2	22.6	4.5	3.6
Incr Delay (d2), s/veh	1.1	0.0	0.0	0.1	0.0	0.0	6.3	0.2	0.0	26.2	0.4	0.0
Initial Q Delay(d3),s/veh	0.0	0.0	0.0	0.0	0.0	0.0	0.0	0.0	0.0	0.0	0.0	0.0
%ile BackOfQ(50%),veh/ln	0.0	0.0	0.0	0.1	0.0	0.0	0.4	1.1	0.0	0.1	2.2	0.0
LnGrp Delay(d),s/veh	21.6	0.0	0.0	19.8	0.0	0.0	28.0	3.7	3.2	48.8	4.9	3.7
LnGrp LOS	C			B			C	A	A	D	A	A
Approach Vol, veh/h		74			11			411			696	
Approach Delay, s/veh		21.6			19.8			5.3			5.2	
Approach LOS		C			B			A			A	
Timer	1	2	3	4	5	6	7	8				
Assigned Phs	1	2		4	5	6		8				
Phs Duration (G+Y+Rc), s	4.7	33.0		7.8	5.9	31.8		7.8				
Change Period (Y+Rc), s	4.5	4.5		4.5	4.5	4.5		4.5				
Max Green Setting (Gmax), s	27.3			26.1	13.1	27.3		26.1				
Max Q Clear Time (g_c+I), s	4.1			4.0	2.7	6.4		2.3				
Green Ext Time (p_c), s	0.0	2.5		0.3	0.0	4.8		0.0				
Intersection Summary												
HCM 2010 Ctrl Delay				6.4								
HCM 2010 LOS				A								

Intersection												
Int Delay, s/veh	0.3											
Movement	EBL	EBT	EBR	WBL	WBT	WBR	NBL	NBT	NBR	SBL	SBT	SBR
Lane Configurations		↔			↔			↔			↔	
Traffic Vol, veh/h	0	0	0	7	2	5	0	606	7	9	591	0
Future Vol, veh/h	0	0	0	7	2	5	0	606	7	9	591	0
Conflicting Peds, #/hr	0	0	0	0	0	0	0	0	0	0	0	0
Sign Control	Stop	Stop	Stop	Stop	Stop	Stop	Free	Free	Free	Free	Free	Free
RT Channelized	-	-	None	-	-	None	-	-	None	-	-	None
Storage Length	-	-	-	-	-	-	-	-	-	-	-	-
Veh in Median Storage, #	-	0	-	-	0	-	-	0	-	-	0	-
Grade, %	-	0	-	-	0	-	-	0	-	-	0	-
Peak Hour Factor	92	92	92	92	92	92	92	92	92	92	92	92
Heavy Vehicles, %	2	2	2	2	2	2	2	2	2	2	2	2
Mvmt Flow	0	0	0	8	2	5	0	659	8	10	642	0

Major/Minor	Minor2		Minor1		Major1		Major2					
Conflicting Flow All	993	1329	321	1004	1325	334	642	0	0	667	0	0
Stage 1	662	662	-	663	663	-	-	-	-	-	-	-
Stage 2	331	667	-	341	662	-	-	-	-	-	-	-
Critical Hdwy	7.54	6.54	6.94	7.54	6.54	6.94	4.14	-	-	4.14	-	-
Critical Hdwy Stg 1	6.54	5.54	-	6.54	5.54	-	-	-	-	-	-	-
Critical Hdwy Stg 2	6.54	5.54	-	6.54	5.54	-	-	-	-	-	-	-
Follow-up Hdwy	3.52	4.02	3.32	3.52	4.02	3.32	2.22	-	-	2.22	-	-
Pot Cap-1 Maneuver	200	154	675	198	156	662	939	-	-	919	-	-
Stage 1	417	457	-	417	457	-	-	-	-	-	-	-
Stage 2	656	455	-	647	457	-	-	-	-	-	-	-
Platoon blocked, %	-	-	-	-	-	-	-	-	-	-	-	-
Mov Cap-1 Maneuver	194	151	675	193	152	662	939	-	-	919	-	-
Mov Cap-2 Maneuver	194	151	-	193	152	-	-	-	-	-	-	-
Stage 1	417	449	-	417	457	-	-	-	-	-	-	-
Stage 2	648	455	-	636	449	-	-	-	-	-	-	-

Approach	EB	WB	NB	SB
HCM Control Delay, s	0	20.6	0	0.2
HCM LOS	A	C		

Minor Lane/Major Mvmt	NBL	NBT	NBR	EBLn1	WBLn1	SBL	SBT	SBR
Capacity (veh/h)	939	-	-	-	246	919	-	-
HCM Lane V/C Ratio	-	-	-	-	0.062	0.011	-	-
HCM Control Delay (s)	0	-	-	0	20.6	9	0.1	-
HCM Lane LOS	A	-	-	A	C	A	A	-
HCM 95th %ile Q(veh)	0	-	-	-	0.2	0	-	-

HCM 2010 Signalized Intersection Summary
 4: Harris Road & Dogwood Rd

Ex + Total Project PM
 09/10/2018

Movement	EBL	EBT	EBR	WBL	WBT	WBR	NBL	NBT	NBR	SBL	SBT	SBR
Lane Configurations		⇕			⇕			⇕			⇕	
Traffic Volume (veh/h)	1	18	2	10	13	2	0	119	1	4	202	3
Future Volume (veh/h)	1	18	2	10	13	2	0	119	1	4	202	3
Number	7	4	14	3	8	18	5	2	12	1	6	16
Initial Q (Qb), veh	0	0	0	0	0	0	0	0	0	0	0	0
Ped-Bike Adj(A_pbT)	1.00		1.00	1.00		1.00	1.00		1.00	1.00		1.00
Parking Bus, Adj	1.00	1.00	1.00	1.00	1.00	1.00	1.00	1.00	1.00	1.00	1.00	1.00
Adj Sat Flow, veh/h/ln	1900	1863	1900	1900	1863	1900	1900	1863	1900	1900	1863	1900
Adj Flow Rate, veh/h	1	20	2	11	14	2	0	129	1	4	220	3
Adj No. of Lanes	0	1	0	0	1	0	0	1	0	0	1	0
Peak Hour Factor	0.92	0.92	0.92	0.92	0.92	0.92	0.92	0.92	0.92	0.92	0.92	0.92
Percent Heavy Veh, %	2	2	2	2	2	2	2	2	2	2	2	2
Cap, veh/h	90	662	64	334	390	49	0	738	6	84	729	10
Arrive On Green	0.40	0.40	0.40	0.40	0.40	0.40	0.00	0.40	0.40	0.40	0.40	0.40
Sat Flow, veh/h	15	1655	159	552	976	122	0	1846	14	8	1823	25
Grp Volume(v), veh/h	23	0	0	27	0	0	0	0	130	227	0	0
Grp Sat Flow(s),veh/h/ln	1830	0	0	1650	0	0	0	0	1860	1855	0	0
Q Serve(g_s), s	0.0	0.0	0.0	0.0	0.0	0.0	0.0	0.0	2.0	0.0	0.0	0.0
Cycle Q Clear(g_c), s	0.3	0.0	0.0	0.4	0.0	0.0	0.0	0.0	2.0	3.8	0.0	0.0
Prop In Lane	0.04		0.09	0.41		0.07	0.00		0.01	0.02		0.01
Lane Grp Cap(c), veh/h	815	0	0	773	0	0	0	0	744	823	0	0
V/C Ratio(X)	0.03	0.00	0.00	0.03	0.00	0.00	0.00	0.00	0.17	0.28	0.00	0.00
Avail Cap(c_s), veh/h	815	0	0	773	0	0	0	0	744	823	0	0
HCM Platoon Ratio	1.00	1.00	1.00	1.00	1.00	1.00	1.00	1.00	1.00	1.00	1.00	1.00
Upstream Filter(I)	1.00	0.00	0.00	1.00	0.00	0.00	0.00	0.00	1.00	1.00	0.00	0.00
Uniform Delay (d), s/veh	8.2	0.0	0.0	8.2	0.0	0.0	0.0	0.0	8.7	9.2	0.0	0.0
Incr Delay (d2), s/veh	0.1	0.0	0.0	0.1	0.0	0.0	0.0	0.0	0.5	0.8	0.0	0.0
Initial Q Delay(d3),s/veh	0.0	0.0	0.0	0.0	0.0	0.0	0.0	0.0	0.0	0.0	0.0	0.0
%ile BackOfQ(50%),veh/ln	0.2	0.0	0.0	0.2	0.0	0.0	0.0	0.0	1.1	2.1	0.0	0.0
LnGrp Delay(d),s/veh	8.3	0.0	0.0	8.3	0.0	0.0	0.0	0.0	9.2	10.1	0.0	0.0
LnGrp LOS	A			A					A	B		
Approach Vol, veh/h		23			27			130			227	
Approach Delay, s/veh		8.3			8.3			9.2			10.1	
Approach LOS		A			A			A			B	
Timer	1	2	3	4	5	6	7	8				
Assigned Phs		2		4		6		8				
Phs Duration (G+Y+Rc), s		22.5		22.5		22.5		22.5				
Change Period (Y+Rc), s		4.5		4.5		4.5		4.5				
Max Green Setting (Gmax), s		18.0		18.0		18.0		18.0				
Max Q Clear Time (g_c+I1), s		4.0		2.3		5.8		2.4				
Green Ext Time (p_c), s		0.5		0.0		0.9		0.1				
Intersection Summary												
HCM 2010 Ctrl Delay				9.6								
HCM 2010 LOS				A								

HCM 2010 Signalized Intersection Summary
5: SR-111 & Harris Road

Ex + Total Project PM
09/10/2018

	↖	→	↗	↖	←	↗	↖	↑	↗	↘	↓	↙
Movement	EBL	EBT	EBR	WBL	WBT	WBR	NBL	NBT	NBR	SBL	SBT	SBR
Lane Configurations		⇄			⇄		↖	↑↑	↗	↖	↑↑	↗
Traffic Volume (veh/h)	4	10	7	1	9	4	11	289	0	0	599	9
Future Volume (veh/h)	4	10	7	1	9	4	11	289	0	0	599	9
Number	7	4	14	3	8	18	5	2	12	1	6	16
Initial Q (Qb), veh	0	0	0	0	0	0	0	0	0	0	0	0
Ped-Bike Adj(A_pbT)	1.00		1.00	1.00		1.00	1.00		1.00	1.00		1.00
Parking Bus, Adj	1.00	1.00	1.00	1.00	1.00	1.00	1.00	1.00	1.00	1.00	1.00	1.00
Adj Sat Flow, veh/h/ln	1900	1863	1900	1900	1863	1900	1863	1863	1863	1863	1863	1863
Adj Flow Rate, veh/h	4	11	8	1	10	4	12	314	0	0	651	10
Adj No. of Lanes	0	1	0	0	1	0	1	2	1	1	2	1
Peak Hour Factor	0.92	0.92	0.92	0.92	0.92	0.92	0.92	0.92	0.92	0.92	0.92	0.92
Percent Heavy Veh, %	2	2	2	2	2	2	2	2	2	2	2	2
Cap, veh/h	94	33	24	80	48	19	27	2775	1241	3	2411	1079
Arrive On Green	0.04	0.04	0.04	0.04	0.04	0.04	0.02	0.78	0.00	0.00	0.68	0.68
Sat Flow, veh/h	295	812	591	118	1184	474	1774	3539	1583	1774	3539	1583
Grp Volume(v), veh/h	23	0	0	15	0	0	12	314	0	0	651	10
Grp Sat Flow(s),veh/h/ln	1899	0	0	1777	0	0	1774	1770	1583	1774	1770	1583
Q Serve(g_s), s	0.2	0.0	0.0	0.0	0.0	0.0	0.3	1.1	0.0	0.0	3.7	0.1
Cycle Q Clear(g_c), s	0.6	0.0	0.0	0.4	0.0	0.0	0.3	1.1	0.0	0.0	3.7	0.1
Prop In Lane	0.17		0.35	0.07		0.27	1.00		1.00	1.00		1.00
Lane Grp Cap(c), veh/h	151	0	0	147	0	0	27	2775	1241	3	2411	1079
V/C Ratio(X)	0.15	0.00	0.00	0.10	0.00	0.00	0.44	0.11	0.00	0.00	0.27	0.01
Avail Cap(c_a), veh/h	1249	0	0	1296	0	0	173	2775	1241	173	2411	1079
HCM Platoon Ratio	1.00	1.00	1.00	1.00	1.00	1.00	1.00	1.00	1.00	1.00	1.00	1.00
Upstream Filter(I)	1.00	0.00	0.00	1.00	0.00	0.00	1.00	1.00	0.00	0.00	1.00	1.00
Uniform Delay (d), s/veh	23.9	0.0	0.0	23.8	0.0	0.0	25.1	1.3	0.0	0.0	3.2	2.8
Incr Delay (d2), s/veh	0.5	0.0	0.0	0.3	0.0	0.0	10.8	0.1	0.0	0.0	0.3	0.0
Initial Q Delay(d3),s/veh	0.0	0.0	0.0	0.0	0.0	0.0	0.0	0.0	0.0	0.0	0.0	0.0
%ile BackOfQ(50%),veh/ln	0.3	0.0	0.0	0.2	0.0	0.0	0.2	0.6	0.0	0.0	1.8	0.0
LnGrp Delay(d),s/veh	24.4	0.0	0.0	24.1	0.0	0.0	35.9	1.4	0.0	0.0	3.5	2.8
LnGrp LOS	C			C			D	A			A	A
Approach Vol, veh/h		23			15			326			661	
Approach Delay, s/veh		24.4			24.1			2.7			3.5	
Approach LOS		C			C			A			A	
Timer	1	2	3	4	5	6	7	8				
Assigned Phs	1	2		4	5	6		8				
Phs Duration (G+Y+Rc), s	0.0	44.8		6.6	5.3	39.5		6.6				
Change Period (Y+Rc), s		4.5		4.5	4.5	4.5		4.5				
Max Green Setting (Gmax), s		35.0		36.0	5.0	35.0		36.0				
Max Q Clear Time (g_c+I), s		3.1		2.8	2.3	5.7		2.4				
Green Ext Time (p_c), s		0.0		0.1	0.0	5.0		0.0				
Intersection Summary												
HCM 2010 Ctrl Delay				4.0								
HCM 2010 LOS				A								

HCM 2010 Signalized Intersection Summary
6: SR-86 & Worthington Road

Ex + Total Project PM
09/10/2018

Movement	EBL	EBT	EBR	WBL	WBT	WBR	NBL	NBT	NBR	SBL	SBT	SBR
Lane Configurations		↔	↗		↖	↗	↖	↕		↗	↖	
Traffic Volume (veh/h)	45	88	114	58	135	60	121	710	22	31	562	72
Future Volume (veh/h)	45	88	114	58	135	60	121	710	22	31	562	72
Number	7	4	14	3	8	18	5	2	12	1	6	16
Initial Q (Qb), veh	0	0	0	0	0	0	0	0	0	0	0	0
Ped-Bike Adj(A_pbT)	1.00		1.00	1.00		1.00	1.00		1.00	1.00		1.00
Parking Bus, Adj	1.00	1.00	1.00	1.00	1.00	1.00	1.00	1.00	1.00	1.00	1.00	1.00
Adj Sat Flow, veh/h/ln	1900	1863	1863	1900	1863	1863	1863	1863	1900	1863	1863	1900
Adj Flow Rate, veh/h	49	96	124	63	147	65	132	772	24	34	611	78
Adj No. of Lanes	0	1	1	0	1	1	1	2	0	1	2	0
Peak Hour Factor	0.92	0.92	0.92	0.92	0.92	0.92	0.92	0.92	0.92	0.92	0.92	0.92
Percent Heavy Veh, %	2	2	2	2	2	2	2	2	2	2	2	2
Cap, veh/h	69	135	176	80	186	229	166	1709	53	59	1350	172
Arrive On Green	0.11	0.11	0.11	0.14	0.14	0.14	0.09	0.49	0.49	0.03	0.43	0.43
Sat Flow, veh/h	619	1213	1583	551	1285	1583	1774	3504	109	1774	3159	403
Grp Volume(v), veh/h	145	0	124	210	0	65	132	390	406	34	342	347
Grp Sat Flow(s),veh/h/ln	1832	0	1583	1835	0	1583	1774	1770	1844	1774	1770	1792
Q Serve(g_s), s	6.2	0.0	6.1	8.9	0.0	3.0	5.9	11.7	11.7	1.5	11.1	11.1
Cycle Q Clear(g_c), s	6.2	0.0	6.1	8.9	0.0	3.0	5.9	11.7	11.7	1.5	11.1	11.1
Prop In Lane	0.34		1.00	0.30		1.00	1.00		0.06	1.00		0.22
Lane Grp Cap(c), veh/h	204	0	176	266	0	229	166	863	899	59	756	766
V/C Ratio(X)	0.71	0.00	0.70	0.79	0.00	0.28	0.80	0.45	0.45	0.58	0.45	0.45
Avail Cap(c_a), veh/h	420	0	363	421	0	363	231	863	899	156	756	766
HCM Platoon Ratio	1.00	1.00	1.00	1.00	1.00	1.00	1.00	1.00	1.00	1.00	1.00	1.00
Upstream Filter(I)	1.00	0.00	1.00	1.00	0.00	1.00	1.00	1.00	1.00	1.00	1.00	1.00
Uniform Delay (d), s/veh	34.6	0.0	34.6	33.3	0.0	30.8	35.8	13.6	13.6	38.5	16.4	16.4
Incr Delay (d2), s/veh	4.5	0.0	5.0	5.2	0.0	0.7	12.3	1.7	1.6	8.8	1.9	1.9
Initial Q Delay(d3),s/veh	0.0	0.0	0.0	0.0	0.0	0.0	0.0	0.0	0.0	0.0	0.0	0.0
%ile BackOfQ(50%),veh/ln	6.4	0.0	2.9	4.9	0.0	1.3	3.5	6.0	6.3	0.9	5.8	5.9
LnGrp Delay(d),s/veh	39.1	0.0	39.6	38.5	0.0	31.4	48.1	15.3	15.2	47.2	18.4	18.4
LnGrp LOS	D		D	D		C	D	B	B	D	B	B
Approach Vol, veh/h	269						275		928		723	
Approach Delay, s/veh	39.4						36.9		19.9		19.7	
Approach LOS	D						D		B		B	
Timer	1	2	3	4	5	6	7	8				
Assigned Phs	1	2	4		5	6	8					
Phs Duration (G+Y+Rc), s	7.2	43.9	13.5		12.0	39.0	16.2					
Change Period (Y+Rc), s	4.5	4.5	4.5		4.5	4.5	4.5					
Max Green Setting (Gmax), s	37.9		18.5		10.5	34.5	18.5					
Max Q Clear Time (g_c+1/3), s	13.7		8.2		7.9	13.1	10.9					
Green Ext Time (p_c), s	0.0	5.3	0.8		0.1	4.4	0.8					
Intersection Summary												
HCM 2010 Ctrl Delay			24.4									
HCM 2010 LOS			C									

HCM 2010 Signalized Intersection Summary
7: SR-111 & Worthington Rd

Ex + Total Project PM
09/10/2018

	↖	→	↗	↖	←	↗	↖	↑	↗	↘	↓	↖
Movement	EBL	EBT	EBR	WBL	WBT	WBR	NBL	NBT	NBR	SBL	SBT	SBR
Lane Configurations		↔			↔		↖	↑↑	↗	↖	↑↑	↗
Traffic Volume (veh/h)	22	39	44	6	34	7	45	268	3	13	534	34
Future Volume (veh/h)	22	39	44	6	34	7	45	268	3	13	534	34
Number	7	4	14	3	8	18	5	2	12	1	6	16
Initial Q (Qb), veh	0	0	0	0	0	0	0	0	0	0	0	0
Ped-Bike Adj(A_pbT)	1.00		1.00	1.00		1.00	1.00		1.00	1.00		1.00
Parking Bus, Adj	1.00	1.00	1.00	1.00	1.00	1.00	1.00	1.00	1.00	1.00	1.00	1.00
Adj Sat Flow, veh/h/ln	1900	1863	1900	1900	1863	1900	1863	1863	1863	1863	1863	1863
Adj Flow Rate, veh/h	24	42	48	7	37	8	49	291	0	14	580	0
Adj No. of Lanes	0	1	0	0	1	0	1	2	1	1	2	1
Peak Hour Factor	0.92	0.92	0.92	0.92	0.92	0.92	0.92	0.92	0.92	0.92	0.92	0.92
Percent Heavy Veh, %	2	2	2	2	2	2	2	2	2	2	2	2
Cap, veh/h	117	74	73	99	145	29	88	2114	946	31	2000	895
Arrive On Green	0.11	0.11	0.11	0.11	0.11	0.11	0.05	0.60	0.00	0.02	0.57	0.00
Sat Flow, veh/h	250	703	693	135	1375	274	1774	3539	1583	1774	3539	1583
Grp Volume(v), veh/h	114	0	0	52	0	0	49	291	0	14	580	0
Grp Sat Flow(s),veh/h/ln	1647	0	0	1784	0	0	1774	1770	1583	1774	1770	1583
Q Serve(g_s), s	1.8	0.0	0.0	0.0	0.0	0.0	1.3	1.7	0.0	0.4	4.1	0.0
Cycle Q Clear(g_c), s	3.2	0.0	0.0	1.3	0.0	0.0	1.3	1.7	0.0	0.4	4.1	0.0
Prop In Lane	0.21		0.42	0.13		0.15	1.00		1.00	1.00		1.00
Lane Grp Cap(c), veh/h	264	0	0	273	0	0	88	2114	946	31	2000	895
VC Ratio(X)	0.43	0.00	0.00	0.19	0.00	0.00	0.55	0.14	0.00	0.45	0.29	0.00
Avail Cap(c_a), veh/h	966	0	0	1019	0	0	481	2114	946	481	2000	895
HCM Platoon Ratio	1.00	1.00	1.00	1.00	1.00	1.00	1.00	1.00	1.00	1.00	1.00	1.00
Upstream Filter(I)	1.00	0.00	0.00	1.00	0.00	0.00	1.00	0.00	1.00	0.00	1.00	0.00
Uniform Delay (d), s/veh	20.7	0.0	0.0	19.9	0.0	0.0	22.4	4.3	0.0	23.5	5.5	0.0
Incr Delay (d2), s/veh	1.1	0.0	0.0	0.3	0.0	0.0	5.3	0.1	0.0	9.6	0.4	0.0
Initial Q Delay(d3),s/veh	0.0	0.0	0.0	0.0	0.0	0.0	0.0	0.0	0.0	0.0	0.0	0.0
%ile BackOfQ(50%),veh/ln	5	0.0	0.0	0.7	0.0	0.0	0.8	0.9	0.0	0.3	2.1	0.0
LnGrp Delay(d),s/veh	21.8	0.0	0.0	20.2	0.0	0.0	27.7	4.4	0.0	33.1	5.8	0.0
LnGrp LOS	C			C			C	A		C	A	
Approach Vol, veh/h		114			52			340			594	
Approach Delay, s/veh		21.8			20.2			7.8			6.5	
Approach LOS		C			C			A			A	
Timer	1	2	3	4	5	6	7	8				
Assigned Phs	1	2		4	5	6		8				
Phs Duration (G+Y+Rc), s	5.4	33.4		9.6	6.9	31.8		9.6				
Change Period (Y+Rc), s	4.5	4.5		4.5	4.5	4.5		4.5				
Max Green Setting (Gmat), s		27.3		26.1	13.1	27.3		26.1				
Max Q Clear Time (g_c+10), s		3.7		5.2	3.3	6.1		3.3				
Green Ext Time (p_c), s	0.0	1.9		0.5	0.0	4.0		0.2				
Intersection Summary												
HCM 2010 Ctrl Delay					9.1							
HCM 2010 LOS					A							

HCM 2010 Signalized Intersection Summary
 1: SR-86 & Keystone Road

Ex+Total Project +CG AM
 09/10/2018

	↖	→	↗	↖	←	↖	↗	↑	↖	↗	↓	↖
Movement	EBL	EBT	EBR	WBL	WBT	WBR	NBL	NBT	NBR	SBL	SBT	SBR
Lane Configurations		↕			↕		↕	↕	↕	↕	↕	↕
Traffic Volume (veh/h)	35	35	16	32	20	46	17	567	67	58	627	41
Future Volume (veh/h)	35	35	16	32	20	46	17	567	67	58	627	41
Number	7	4	14	3	8	18	5	2	12	1	6	16
Initial Q (Qb), veh	0	0	0	0	0	0	0	0	0	0	0	0
Ped-Bike Adj(A_pbT)	1.00		1.00	1.00		1.00	1.00		1.00	1.00		1.00
Parking Bus, Adj	1.00	1.00	1.00	1.00	1.00	1.00	1.00	1.00	1.00	1.00	1.00	1.00
Adj Sat Flow, veh/h/ln	1900	1863	1900	1900	1863	1900	1863	1863	1863	1863	1863	1863
Adj Flow Rate, veh/h	38	38	17	35	22	50	18	616	73	63	682	45
Adj No. of Lanes	0	1	0	0	1	0	1	2	1	1	2	1
Peak Hour Factor	0.92	0.92	0.92	0.92	0.92	0.92	0.92	0.92	0.92	0.92	0.92	0.92
Percent Heavy Veh, %	2	2	2	2	2	2	2	2	2	2	2	2
Cap, veh/h	144	83	31	126	45	77	39	2158	965	98	2276	1018
Arrive On Green	0.10	0.10	0.10	0.10	0.10	0.10	0.02	0.61	0.61	0.06	0.64	0.64
Sat Flow, veh/h	562	835	313	429	455	776	1774	3539	1583	1774	3539	1583
Grp Volume(v), veh/h	93	0	0	107	0	0	18	616	73	63	682	45
Grp Sat Flow(s),veh/h/ln	1710	0	0	1860	0	0	1774	1770	1583	1774	1770	1583
Q Serve(g_s), s	0.0	0.0	0.0	0.6	0.0	0.0	0.6	4.7	1.1	2.0	4.9	0.6
Cycle Q Clear(g_c), s	2.8	0.0	0.0	3.4	0.0	0.0	0.6	4.7	1.1	2.0	4.9	0.6
Prop In Lane	0.41		0.18	0.33		0.47	1.00		1.00	1.00		1.00
Lane Grp Cap(c), veh/h	259	0	0	249	0	0	39	2158	965	98	2276	1018
V/C Ratio(X)	0.36	0.00	0.00	0.43	0.00	0.00	0.47	0.29	0.08	0.64	0.30	0.04
Avail Cap(c_a), veh/h	1078	0	0	1061	0	0	155	2158	965	155	2276	1018
HCM Platoon Ratio	1.00	1.00	1.00	1.00	1.00	1.00	1.00	1.00	1.00	1.00	1.00	1.00
Upstream Filter(I)	1.00	0.00	0.00	1.00	0.00	0.00	1.00	1.00	1.00	1.00	1.00	1.00
Uniform Delay (d), s/veh	24.5	0.0	0.0	24.8	0.0	0.0	27.7	5.3	4.6	26.6	4.5	3.8
Incr Delay (d2), s/veh	0.8	0.0	0.0	1.2	0.0	0.0	8.5	0.3	0.2	6.9	0.3	0.1
Initial Q Delay(d3),s/veh	0.0	0.0	0.0	0.0	0.0	0.0	0.0	0.0	0.0	0.0	0.0	0.0
%ile BackOfQ(50%),veh/ln	1.5	0.0	0.0	1.7	0.0	0.0	0.4	2.4	0.5	1.2	2.5	0.3
LnGrp Delay(d),s/veh	25.3	0.0	0.0	25.9	0.0	0.0	36.3	5.6	4.7	33.4	4.9	3.8
LnGrp LOS	C			C			D	A	A	C	A	A
Approach Vol, veh/h		93			107			707			790	
Approach Delay, s/veh		25.3			25.9			6.3			7.1	
Approach LOS		C			C			A			A	
Timer	1	2	3	4	5	6	7	8				
Assigned Phs	1	2		4	5	6		8				
Phs Duration (G+Y+Rc), s	7.7	39.5		10.2	5.7	41.4		10.2				
Change Period (Y+Rc), s	4.5	4.5		4.5	4.5	4.5		4.5				
Max Green Setting (Gmax), s	5.0	35.0		36.0	5.0	35.0		36.0				
Max Q Clear Time (g_c+1), s	4.0	6.7		4.8	2.6	6.9		5.4				
Green Ext Time (p_c), s	0.0	4.8		0.5	0.0	5.3		0.6				

Intersection Summary		
HCM 2010 Ctrl Delay		9.0
HCM 2010 LOS		A

HCM 2010 Signalized Intersection Summary
2: SR-111 & Keystone Road

Ex+Total Project +CG AM
09/10/2018

Movement	EBL	EBT	EBR	WBL	WBT	WBR	NBL	NBT	NBR	SBL	SBT	SBR
Lane Configurations		⇄			⇄		↑	↑↑	↑	↑	↑↑	↑
Traffic Volume (veh/h)	14	14	40	2	8	2	55	523	4	1	666	7
Future Volume (veh/h)	14	14	40	2	8	2	55	523	4	1	666	7
Number	7	4	14	3	8	18	5	2	12	1	6	16
Initial Q (Qb), veh	0	0	0	0	0	0	0	0	0	0	0	0
Ped-Bike Adj(A_pbT)	1.00		1.00	1.00		1.00	1.00		1.00	1.00		1.00
Parking Bus, Adj	1.00	1.00	1.00	1.00	1.00	1.00	1.00	1.00	1.00	1.00	1.00	1.00
Adj Sat Flow, veh/h/ln	1900	1863	1900	1900	1863	1900	1863	1863	1863	1863	1863	1863
Adj Flow Rate, veh/h	15	15	43	2	9	2	60	568	4	1	724	8
Adj No. of Lanes	0	1	0	0	1	0	1	2	1	1	2	1
Peak Hour Factor	0.92	0.92	0.92	0.92	0.92	0.92	0.92	0.92	0.92	0.92	0.92	0.92
Percent Heavy Veh, %	2	2	2	2	2	2	2	2	2	2	2	2
Cap, veh/h	113	27	68	102	95	20	103	2261	1011	4	2061	922
Arrive On Green	0.07	0.07	0.07	0.07	0.07	0.07	0.06	0.64	0.64	0.00	0.58	0.58
Sat Flow, veh/h	280	378	944	184	1326	275	1774	3539	1583	1774	3539	1583
Grp Volume(v), veh/h	73	0	0	13	0	0	60	568	4	1	724	8
Grp Sat Flow(s),veh/h/ln	1603	0	0	1785	0	0	1774	1770	1583	1774	1770	1583
Q Serve(g_s), s	1.6	0.0	0.0	0.0	0.0	0.0	1.5	3.2	0.0	0.0	5.0	0.1
Cycle Q Clear(g_c), s	2.1	0.0	0.0	0.3	0.0	0.0	1.5	3.2	0.0	0.0	5.0	0.1
Prop In Lane	0.21		0.59	0.15		0.15	1.00		1.00	1.00		1.00
Lane Grp Cap(c), veh/h	208	0	0	217	0	0	103	2261	1011	4	2061	922
V/C Ratio(X)	0.35	0.00	0.00	0.06	0.00	0.00	0.58	0.25	0.00	0.26	0.35	0.01
Avail Cap(c_a), veh/h	978	0	0	1048	0	0	496	2261	1011	496	2061	922
HCM Platoon Ratio	1.00	1.00	1.00	1.00	1.00	1.00	1.00	1.00	1.00	1.00	1.00	1.00
Upstream Filter(I)	1.00	0.00	0.00	1.00	0.00	0.00	1.00	1.00	1.00	1.00	1.00	1.00
Uniform Delay (d), s/veh	21.1	0.0	0.0	20.3	0.0	0.0	21.5	3.6	3.1	23.4	5.1	4.1
Incr Delay (d2), s/veh	1.0	0.0	0.0	0.1	0.0	0.0	5.2	0.3	0.0	33.5	0.5	0.0
Initial Q Delay(d3),s/veh	0.0	0.0	0.0	0.0	0.0	0.0	0.0	0.0	0.0	0.0	0.0	0.0
%ile BackOfQ(50%),veh/ln	0.0	0.0	0.0	0.2	0.0	0.0	0.9	1.7	0.0	0.0	2.5	0.0
LnGrp Delay(d),s/veh	22.2	0.0	0.0	20.5	0.0	0.0	26.7	3.9	3.1	56.9	5.8	4.1
LnGrp LOS	C			C			C	A	A	E	A	A
Approach Vol, veh/h		73			13			632			733	
Approach Delay, s/veh		22.2			20.5			6.1			5.7	
Approach LOS		C			C			A			A	
Timer	1	2	3	4	5	6	7	8				
Assigned Phs	1	2		4	5	6		8				
Phs Duration (G+Y+Rc), s	4.6	34.4		7.9	7.2	31.8		7.9				
Change Period (Y+Rc), s	4.5	4.5		4.5	4.5	4.5		4.5				
Max Green Setting (Gmax), s		27.3		26.1	13.1	27.3		26.1				
Max Q Clear Time (g_c+1), s		5.2		4.1	3.5	7.0		2.3				
Green Ext Time (p_c), s		0.0		0.3	0.1	5.1		0.0				
Intersection Summary												
HCM 2010 Ctrl Delay					6.8							
HCM 2010 LOS					A							

Intersection												
Int Delay, s/veh	0.4											
Movement	EBL	EBT	EBR	WBL	WBT	WBR	NBL	NBT	NBR	SBL	SBT	SBR
Lane Configurations		↕			↕			↕			↕	
Traffic Vol, veh/h	0	0	0	3	2	17	1	647	13	10	656	1
Future Vol, veh/h	0	0	0	3	2	17	1	647	13	10	656	1
Conflicting Peds, #/hr	0	0	0	0	0	0	0	0	0	0	0	0
Sign Control	Stop	Stop	Stop	Stop	Stop	Stop	Free	Free	Free	Free	Free	Free
RT Channelized	-	-	None	-	-	None	-	-	None	-	-	None
Storage Length	-	-	-	-	-	-	-	-	-	-	-	-
Veh in Median Storage, #	-	0	-	-	0	-	-	0	-	-	0	-
Grade, %	-	0	-	-	0	-	-	0	-	-	0	-
Peak Hour Factor	92	92	92	92	92	92	92	92	92	92	92	92
Heavy Vehicles, %	2	2	2	2	2	2	2	2	2	2	2	2
Mvmt Flow	0	0	0	3	2	18	1	703	14	11	713	1

Major/Minor	Minor2		Minor1		Major1		Major2					
Conflicting Flow All	1091	1455	357	1091	1448	359	714	0	0	717	0	0
Stage 1	736	736	-	712	712	-	-	-	-	-	-	-
Stage 2	355	719	-	379	736	-	-	-	-	-	-	-
Critical Hdwy	7.54	6.54	6.94	7.54	6.54	6.94	4.14	-	-	4.14	-	-
Critical Hdwy Stg 1	6.54	5.54	-	6.54	5.54	-	-	-	-	-	-	-
Critical Hdwy Stg 2	6.54	5.54	-	6.54	5.54	-	-	-	-	-	-	-
Follow-up Hdwy	3.52	4.02	3.32	3.52	4.02	3.32	2.22	-	-	2.22	-	-
Pot Cap-1 Maneuver	169	129	639	169	130	638	882	-	-	880	-	-
Stage 1	377	423	-	389	434	-	-	-	-	-	-	-
Stage 2	635	431	-	615	423	-	-	-	-	-	-	-
Platoon blocked, %	-	-	-	-	-	-	-	-	-	-	-	-
Mov Cap-1 Maneuver	159	126	639	166	127	638	882	-	-	880	-	-
Mov Cap-2 Maneuver	159	126	-	166	127	-	-	-	-	-	-	-
Stage 1	376	414	-	388	433	-	-	-	-	-	-	-
Stage 2	612	430	-	602	414	-	-	-	-	-	-	-

Approach	EB	WB	NB	SB
HCM Control Delay, s	0	15.6	0	0.2
HCM LOS	A	C		

Minor Lane/Major Mvmt	NBL	NBT	NBR	EBLn1	WBLn1	SBL	SBT	SBR
Capacity (veh/h)	882	-	-	-	364	880	-	-
HCM Lane V/C Ratio	0.001	-	-	-	0.066	0.012	-	-
HCM Control Delay (s)	9.1	0	-	0	15.6	9.1	0.1	-
HCM Lane LOS	A	A	-	A	C	A	A	-
HCM 95th %ile Q(veh)	0	-	-	-	0.2	0	-	-

HCM 2010 Signalized Intersection Summary
4: Harris Road & Dogwood Rd

Ex+Total Project +CG AM
09/10/2018

	↖	→	↗	↖	←	↗	↖	↑	↗	↘	↓	↘
Movement	EBL	EBT	EBR	WBL	WBT	WBR	NBL	NBT	NBR	SBL	SBT	SBR
Lane Configurations		↕			↕			↕			↕	
Traffic Volume (veh/h)	2	4	4	2	33	5	1	120	2	2	192	1
Future Volume (veh/h)	2	4	4	2	33	5	1	120	2	2	192	1
Number	7	4	14	3	8	18	5	2	12	1	6	16
Initial Q (Qb), veh	0	0	0	0	0	0	0	0	0	0	0	0
Ped-Bike Adj(A_pbT)	1.00		1.00	1.00		1.00	1.00		1.00	1.00		1.00
Parking Bus, Adj	1.00	1.00	1.00	1.00	1.00	1.00	1.00	1.00	1.00	1.00	1.00	1.00
Adj Sat Flow, veh/h/ln	1900	1863	1900	1900	1863	1900	1900	1863	1900	1900	1863	1900
Adj Flow Rate, veh/h	2	4	4	2	36	5	1	130	2	2	209	1
Adj No. of Lanes	0	1	0	0	1	0	0	1	0	0	1	0
Peak Hour Factor	0.92	0.92	0.92	0.92	0.92	0.92	0.92	0.92	0.92	0.92	0.92	0.92
Percent Heavy Veh, %	2	2	2	2	2	2	2	2	2	2	2	2
Cap, veh/h	176	321	267	91	636	85	82	731	11	82	739	4
Arrive On Green	0.40	0.40	0.40	0.40	0.40	0.40	0.40	0.40	0.40	0.40	0.40	0.40
Sat Flow, veh/h	200	802	668	17	1591	212	2	1826	28	3	1847	9
Grp Volume(v), veh/h	10	0	0	43	0	0	133	0	0	212	0	0
Grp Sat Flow(s),veh/h/ln	1671	0	0	1820	0	0	1856	0	0	1860	0	0
Q Serve(g_s), s	0.0	0.0	0.0	0.0	0.0	0.0	0.0	0.0	0.0	0.0	0.0	0.0
Cycle Q Clear(g_c), s	0.2	0.0	0.0	0.7	0.0	0.0	2.1	0.0	0.0	3.5	0.0	0.0
Prop In Lane	0.20		0.40	0.05		0.12	0.01		0.02	0.01		0.00
Lane Grp Cap(c), veh/h	764	0	0	812	0	0	823	0	0	825	0	0
V/C Ratio(X)	0.01	0.00	0.00	0.06	0.00	0.00	0.16	0.00	0.00	0.26	0.00	0.00
Avail Cap(c_a), veh/h	764	0	0	812	0	0	823	0	0	825	0	0
HCM Platoon Ratio	1.00	1.00	1.00	1.00	1.00	1.00	1.00	1.00	1.00	1.00	1.00	1.00
Upstream Filter(I)	1.00	0.00	0.00	1.00	0.00	0.00	1.00	0.00	0.00	1.00	0.00	0.00
Uniform Delay (d), s/veh	8.1	0.0	0.0	8.3	0.0	0.0	8.7	0.0	0.0	9.1	0.0	0.0
Incr Delay (d2), s/veh	0.0	0.0	0.0	0.1	0.0	0.0	0.4	0.0	0.0	0.8	0.0	0.0
Initial Q Delay(d3),s/veh	0.0	0.0	0.0	0.0	0.0	0.0	0.0	0.0	0.0	0.0	0.0	0.0
%ile BackOfQ(50%),veh/ln	0.1	0.0	0.0	0.4	0.0	0.0	1.2	0.0	0.0	1.9	0.0	0.0
LnGrp Delay(d),s/veh	8.2	0.0	0.0	8.4	0.0	0.0	9.1	0.0	0.0	9.9	0.0	0.0
LnGrp LOS	A			A			A			A		
Approach Vol, veh/h		10			43			133			212	
Approach Delay, s/veh		8.2			8.4			9.1			9.9	
Approach LOS		A			A			A			A	
Timer	1	2	3	4	5	6	7	8				
Assigned Phs		2		4		6		8				
Phs Duration (G+Y+Rc), s		22.5		22.5		22.5		22.5				
Change Period (Y+Rc), s		4.5		4.5		4.5		4.5				
Max Green Setting (Gmax), s		18.0		18.0		18.0		18.0				
Max Q Clear Time (g_c+I1), s		4.1		2.2		5.5		2.7				
Green Ext Time (p_c), s		0.5		0.0		0.9		0.1				
Intersection Summary												
HCM 2010 Ctrl Delay				9.4								
HCM 2010 LOS				A								

HCM 2010 Signalized Intersection Summary
5: SR-111 & Harris Road

Ex+Total Project +CG AM
09/10/2018

Movement	EBL	EBT	EBR	WBL	WBT	WBR	NBL	NBT	NBR	SBL	SBT	SBR
Lane Configurations		⇄			⇄		↖	↗	↖	↗	↖	↗
Traffic Volume (veh/h)	8	10	7	2	10	0	28	565	0	1	679	12
Future Volume (veh/h)	8	10	7	2	10	0	28	565	0	1	679	12
Number	7	4	14	3	8	18	5	2	12	1	6	16
Initial Q (Qb), veh	0	0	0	0	0	0	0	0	0	0	0	0
Ped-Bike Adj(A_pbT)	1.00		1.00	1.00		1.00	1.00		1.00	1.00		1.00
Parking Bus, Adj	1.00	1.00	1.00	1.00	1.00	1.00	1.00	1.00	1.00	1.00	1.00	1.00
Adj Sat Flow, veh/h/ln	1900	1863	1900	1900	1863	1900	1863	1863	1863	1863	1863	1863
Adj Flow Rate, veh/h	9	11	8	2	11	0	30	614	0	1	738	13
Adj No. of Lanes	0	1	0	0	1	0	1	2	1	1	2	1
Peak Hour Factor	0.92	0.92	0.92	0.92	0.92	0.92	0.92	0.92	0.92	0.92	0.92	0.92
Percent Heavy Veh, %	2	2	2	2	2	2	2	2	2	2	2	2
Cap, veh/h	113	28	20	91	66	0	60	2473	1106	3	2358	1055
Arrive On Green	0.04	0.04	0.04	0.04	0.04	0.00	0.03	0.70	0.00	0.00	0.67	0.67
Sat Flow, veh/h	529	646	470	270	1529	0	1774	3539	1583	1774	3539	1583
Grp Volume(v), veh/h	28	0	0	13	0	0	30	614	0	1	738	13
Grp Sat Flow(s),veh/h/ln	1645	0	0	1799	0	0	1774	1770	1583	1774	1770	1583
Q Serve(g_s), s	0.5	0.0	0.0	0.0	0.0	0.0	0.9	3.3	0.0	0.0	4.6	0.1
Cycle Q Clear(g_c), s	0.8	0.0	0.0	0.4	0.0	0.0	0.9	3.3	0.0	0.0	4.6	0.1
Prop In Lane	0.32		0.29	0.15		0.00	1.00		1.00	1.00		1.00
Lane Grp Cap(c), veh/h	161	0	0	156	0	0	60	2473	1106	3	2358	1055
V/C Ratio(X)	0.17	0.00	0.00	0.08	0.00	0.00	0.50	0.25	0.00	0.30	0.31	0.01
Avail Cap(c_a), veh/h	1195	0	0	1293	0	0	169	2473	1106	169	2358	1055
HCM Platoon Ratio	1.00	1.00	1.00	1.00	1.00	1.00	1.00	1.00	1.00	1.00	1.00	1.00
Upstream Filter(I)	1.00	0.00	0.00	1.00	0.00	0.00	1.00	1.00	0.00	1.00	1.00	1.00
Uniform Delay (d), s/veh	24.4	0.0	0.0	24.2	0.0	0.0	24.9	2.9	0.0	26.2	3.7	2.9
Incr Delay (d2), s/veh	0.5	0.0	0.0	0.2	0.0	0.0	6.3	0.2	0.0	42.7	0.3	0.0
Initial Q Delay(d3),s/veh	0.0	0.0	0.0	0.0	0.0	0.0	0.0	0.0	0.0	0.0	0.0	0.0
%ile BackOfQ(50%),veh/ln	0.4	0.0	0.0	0.2	0.0	0.0	0.5	1.7	0.0	0.1	2.3	0.1
LnGrp Delay(d),s/veh	25.0	0.0	0.0	24.5	0.0	0.0	31.3	3.1	0.0	68.9	4.0	3.0
LnGrp LOS	C			C			C	A		E	A	A
Approach Vol, veh/h		28			13			644			752	
Approach Delay, s/veh		25.0			24.5			4.4			4.1	
Approach LOS		C			C			A			A	
Timer	1	2	3	4	5	6	7	8				
Assigned Phs	1	2		4	5	6		8				
Phs Duration (G+Y+Rc), s	41.2			6.8	6.3	39.5		6.8				
Change Period (Y+Rc), s	4.5	4.5		4.5	4.5	4.5		4.5				
Max Green Setting (Gmax), s	35.0			36.0	5.0	35.0		36.0				
Max Q Clear Time (g_c+I), s	5.3			2.8	2.9	6.6		2.4				
Green Ext Time (p_c), s	0.0	4.6		0.1	0.0	5.8		0.0				
Intersection Summary												
HCM 2010 Ctrl Delay				4.8								
HCM 2010 LOS				A								

HCM 2010 Signalized Intersection Summary
6: SR-86 & Worthington Road

Ex+Total Project +CG AM
09/10/2018

	↖	→	↗	↖	←	↗	↖	↑	↗	↘	↓	↙
Movement	EBL	EBT	EBR	WBL	WBT	WBR	NBL	NBT	NBR	SBL	SBT	SBR
Lane Configurations		↖	↗		↖	↗	↖	↑	↗	↘	↓	↙
Traffic Volume (veh/h)	80	182	197	80	144	98	124	623	88	55	967	94
Future Volume (veh/h)	80	182	197	80	144	98	124	623	88	55	967	94
Number	7	4	14	3	8	18	5	2	12	1	6	16
Initial Q (Qb), veh	0	0	0	0	0	0	0	0	0	0	0	0
Ped-Bike Adj(A_pbT)	1.00		1.00	1.00		1.00	1.00		1.00	1.00		1.00
Parking Bus, Adj	1.00	1.00	1.00	1.00	1.00	1.00	1.00	1.00	1.00	1.00	1.00	1.00
Adj Sat Flow, veh/h/ln	1900	1863	1863	1900	1863	1863	1863	1863	1900	1863	1863	1900
Adj Flow Rate, veh/h	87	198	214	87	157	107	135	677	74	60	1051	102
Adj No. of Lanes	0	1	1	0	1	1	1	2	0	1	2	0
Peak Hour Factor	0.92	0.92	0.92	0.92	0.92	0.92	0.92	0.92	0.92	0.92	0.92	0.92
Percent Heavy Veh, %	2	2	2	2	2	2	2	2	2	2	2	2
Cap, veh/h	100	227	283	103	185	249	165	1384	151	77	1240	120
Arrive On Green	0.18	0.18	0.18	0.16	0.16	0.16	0.09	0.43	0.43	0.04	0.38	0.38
Sat Flow, veh/h	560	1275	1583	653	1178	1583	1774	3219	352	1774	3260	316
Grp Volume(v), veh/h	285	0	214	244	0	107	135	372	379	60	570	583
Grp Sat Flow(s),veh/h/ln	1835	0	1583	1830	0	1583	1774	1770	1801	1774	1770	1807
Q Serve(g_s), s	14.3	0.0	12.1	12.2	0.0	5.8	7.1	14.3	14.4	3.2	27.8	27.9
Cycle Q Clear(g_c), s	14.3	0.0	12.1	12.2	0.0	5.8	7.1	14.3	14.4	3.2	27.8	27.9
Prop In Lane	0.31		1.00	0.36		1.00	1.00		0.20	1.00		0.18
Lane Grp Cap(c), veh/h	327	0	283	288	0	249	165	761	774	77	673	687
V/C Ratio(X)	0.87	0.00	0.78	0.85	0.00	0.43	0.82	0.49	0.49	0.78	0.85	0.85
Avail Cap(c_a), veh/h	359	0	310	351	0	304	178	761	774	169	673	687
HCM Platoon Ratio	1.00	1.00	1.00	1.00	1.00	1.00	1.00	1.00	1.00	1.00	1.00	1.00
Upstream Filter(I)	1.00	0.00	1.00	1.00	0.00	1.00	1.00	1.00	1.00	1.00	1.00	1.00
Uniform Delay (d), s/veh	37.7	0.0	36.8	39.7	0.0	35.9	42.0	19.4	19.4	44.7	26.8	26.8
Incr Delay (d2), s/veh	18.9	0.0	9.4	14.8	0.0	1.2	23.3	2.2	2.2	15.2	12.6	12.4
Initial Q Delay(d3),s/veh	0.0	0.0	0.0	0.0	0.0	0.0	0.0	0.0	0.0	0.0	0.0	0.0
%ile BackOfQ(50%),veh/ln	8.9	0.0	6.0	7.4	0.0	2.6	4.5	7.4	7.6	1.9	15.8	16.3
LnGrp Delay(d),s/veh	56.6	0.0	46.3	53.5	0.0	37.1	65.3	21.7	21.7	59.8	39.3	39.2
LnGrp LOS	E		D	D		D	E	C	C	E	D	D
Approach Vol, veh/h		499			351			886			1213	
Approach Delay, s/veh		52.2			48.5			28.3			40.3	
Approach LOS		D			D			C			D	
Timer	1	2	3	4	5	6	7	8				
Assigned Phs	1	2		4	5	6		8				
Phs Duration (G+Y+Rc), s	45.1			21.3	13.3	40.4		19.4				
Change Period (Y+Rc), s	4.5	4.5		4.5	4.5	4.5		4.5				
Max Green Setting (Gmax), s	36.4			18.5	9.5	35.9		18.1				
Max Q Clear Time (g_c+H), s	16.4			16.3	9.1	29.9		14.2				
Green Ext Time (p_c), s	0.0	4.7		0.6	0.0	3.6		0.6				
Intersection Summary												
HCM 2010 Ctrl Delay			39.7									
HCM 2010 LOS			D									

HCM 2010 Signalized Intersection Summary
7: SR-111 & Worthington Rd

Ex+Total Project +CG AM
09/10/2018

Movement	EBL	EBT	EBR	WBL	WBT	WBR	NBL	NBT	NBR	SBL	SBT	SBR
Lane Configurations		↕			↕		↖	↗	↖	↗	↖	↗
Traffic Volume (veh/h)	32	60	118	5	83	18	90	530	2	5	538	158
Future Volume (veh/h)	32	60	118	5	83	18	90	530	2	5	538	158
Number	7	4	14	3	8	18	5	2	12	1	6	16
Initial Q (Qb), veh	0	0	0	0	0	0	0	0	0	0	0	0
Ped-Bike Adj(A_pbT)	1.00		1.00	1.00		1.00	1.00		1.00	1.00		1.00
Parking Bus, Adj	1.00	1.00	1.00	1.00	1.00	1.00	1.00	1.00	1.00	1.00	1.00	1.00
Adj Sat Flow, veh/h/ln	1900	1863	1900	1900	1863	1900	1863	1863	1863	1863	1863	1863
Adj Flow Rate, veh/h	35	65	128	5	90	20	98	576	0	5	585	0
Adj No. of Lanes	0	1	0	0	1	0	1	2	1	1	2	1
Peak Hour Factor	0.92	0.92	0.92	0.92	0.92	0.92	0.92	0.92	0.92	0.92	0.92	0.92
Percent Heavy Veh, %	2	2	2	2	2	2	2	2	2	2	2	2
Cap, veh/h	104	105	172	73	274	59	128	1984	888	12	1753	784
Arrive On Green	0.19	0.19	0.19	0.19	0.19	0.19	0.07	0.56	0.00	0.01	0.50	0.00
Sat Flow, veh/h	155	560	915	27	1457	312	1774	3539	1583	1774	3539	1583
Grp Volume(v), veh/h	228	0	0	115	0	0	98	576	0	5	585	0
Grp Sat Flow(s), veh/h/ln	1630	0	0	1797	0	0	1774	1770	1583	1774	1770	1583
Q Serve(g_s), s	3.4	0.0	0.0	0.0	0.0	0.0	3.0	4.7	0.0	0.2	5.5	0.0
Cycle Q Clear(g_c), s	7.2	0.0	0.0	3.0	0.0	0.0	3.0	4.7	0.0	0.2	5.5	0.0
Prop In Lane	0.15		0.56	0.04		0.17	1.00		1.00	1.00		1.00
Lane Grp Cap(c), veh/h	382	0	0	406	0	0	128	1984	888	12	1753	784
V/C Ratio(X)	0.60	0.00	0.00	0.28	0.00	0.00	0.77	0.29	0.00	0.42	0.33	0.00
Avail Cap(c_a), veh/h	836	0	0	910	0	0	422	1984	888	422	1753	784
HCM Platoon Ratio	1.00	1.00	1.00	1.00	1.00	1.00	1.00	1.00	1.00	1.00	1.00	1.00
Upstream Filter(I)	1.00	0.00	0.00	1.00	0.00	0.00	1.00	1.00	0.00	1.00	1.00	0.00
Uniform Delay (d), s/veh	21.0	0.0	0.0	19.4	0.0	0.0	25.1	6.4	0.0	27.3	8.4	0.0
Incr Delay (d2), s/veh	1.5	0.0	0.0	0.4	0.0	0.0	9.2	0.4	0.0	22.0	0.5	0.0
Initial Q Delay(d3),s/veh	0.0	0.0	0.0	0.0	0.0	0.0	0.0	0.0	0.0	0.0	0.0	0.0
%ile BackOfQ(50%),veh/ln	8.4	0.0	0.0	1.5	0.0	0.0	1.8	2.3	0.0	0.1	2.8	0.0
LnGrp Delay(d),s/veh	22.5	0.0	0.0	19.8	0.0	0.0	34.3	6.7	0.0	49.3	8.9	0.0
LnGrp LOS	C			B			C	A		D	A	
Approach Vol, veh/h		228			115			674			590	
Approach Delay, s/veh		22.5			19.8			10.7			9.3	
Approach LOS		C			B			B			A	
Timer	1	2	3	4	5	6	7	8				
Assigned Phs	1	2		4	5	6		8				
Phs Duration (G+Y+Rc), s	4.9	35.4		14.9	8.5	31.8		14.9				
Change Period (Y+Rc), s	4.5	4.5		4.5	4.5	4.5		4.5				
Max Green Setting (Gmax), s	27.3			26.1	13.1	27.3		26.1				
Max Q Clear Time (g_c+1), s	6.7			9.2	5.0	7.5		5.0				
Green Ext Time (p_c), s	0.0	3.9		1.2	0.1	3.9		0.5				
Intersection Summary												
HCM 2010 Ctrl Delay				12.5								
HCM 2010 LOS				B								

HCM 2010 Signalized Intersection Summary
1: SR-86 & Keystone Road

Ex + Total Project + CG PM
09/06/2018

	↖	→	↘	↙	←	↖	↙	↑	↘	↙	↓	↘
Movement	EBL	EBT	EBR	WBL	WBT	WBR	NBL	NBT	NBR	SBL	SBT	SBR
Lane Configurations		↕			↕		↖	↕	↗	↖	↕	↗
Traffic Volume (veh/h)	37	16	24	23	26	47	20	693	22	50	678	18
Future Volume (veh/h)	37	16	24	23	26	47	20	693	22	50	678	18
Number	7	4	14	3	8	18	5	2	12	1	6	16
Initial Q (Qb), veh	0	0	0	0	0	0	0	0	0	0	0	0
Ped-Bike Adj(A_pbT)	1.00		1.00	1.00		1.00	1.00		1.00	1.00		1.00
Parking Bus, Adj	1.00		1.00	1.00		1.00	1.00		1.00	1.00		1.00
Adj Sat Flow, veh/h/ln	1900	1863	1900	1900	1863	1900	1863	1863	1863	1863	1863	1863
Adj Flow Rate, veh/h	40	17	26	25	28	51	22	753	24	54	737	20
Adj No. of Lanes	0	1	0	0	1	0	1	2	1	1	2	1
Peak Hour Factor	0.92	0.92	0.92	0.92	0.92	0.92	0.92	0.92	0.92	0.92	0.92	0.92
Percent Heavy Veh, %	2	2	2	2	2	2	2	2	2	2	2	2
Cap, veh/h	159	47	51	107	54	80	46	2175	973	89	2262	1012
Arrive On Green	0.10	0.10	0.10	0.10	0.10	0.10	0.03	0.61	0.61	0.05	0.64	0.64
Sat Flow, veh/h	665	484	524	293	556	817	1774	3539	1583	1774	3539	1583
Grp Volume(v), veh/h	83	0	0	104	0	0	22	753	24	54	737	20
Grp Sat Flow(s),veh/h/ln	1673	0	0	1866	0	0	1774	1770	1583	1774	1770	1583
Q Serve(g_s), s	0.0	0.0	0.0	0.8	0.0	0.0	0.7	5.9	0.3	1.7	5.4	0.3
Cycle Q Clear(g_c), s	2.5	0.0	0.0	3.3	0.0	0.0	0.7	5.9	0.3	1.7	5.4	0.3
Prop In Lane	0.48		0.31	0.24		0.49	1.00		1.00	1.00		1.00
Lane Grp Cap(c), veh/h	258	0	0	242	0	0	46	2175	973	89	2262	1012
V/C Ratio(X)	0.32	0.00	0.00	0.43	0.00	0.00	0.48	0.35	0.02	0.60	0.33	0.02
Avail Cap(c_a), veh/h	1050	0	0	1088	0	0	156	2175	973	158	2262	1012
HCM Platoon Ratio	1.00	1.00	1.00	1.00	1.00	1.00	1.00	1.00	1.00	1.00	1.00	1.00
Upstream Filter(I)	1.00	0.00	0.00	1.00	0.00	0.00	1.00	1.00	1.00	1.00	1.00	1.00
Uniform Delay (d), s/veh	24.3	0.0	0.0	24.6	0.0	0.0	27.4	5.4	4.3	28.5	4.7	3.8
Incr Delay (d2), s/veh	0.7	0.0	0.0	1.2	0.0	0.0	7.6	0.4	0.0	6.4	0.4	0.0
Initial Q Delay(d3),s/veh	0.0	0.0	0.0	0.0	0.0	0.0	0.0	0.0	0.0	0.0	0.0	0.0
%ile BackOfQ(50%),veh/ln	1.3	0.0	0.0	1.6	0.0	0.0	0.4	3.0	0.2	1.0	2.7	0.1
LnGrp Delay(d),s/veh	25.0	0.0	0.0	25.9	0.0	0.0	35.0	5.8	4.3	32.9	5.1	3.8
LnGrp LOS	C			C			C	A	A	C	A	A
Approach Vol, veh/h		83			104			799			811	
Approach Delay, s/veh		25.0			25.9			6.6			6.9	
Approach LOS		C			C			A			A	
Timer	1	2	3	4	5	6	7	8				
Assigned Phs	1	2		4	5	6		8				
Phs Duration (G+Y+Rc), s	7.4	39.5		10.1	6.0	40.9		10.1				
Change Period (Y+Rc), s	4.5	4.5		4.5	4.5	4.5		4.5				
Max Green Setting (Gmax), s	5.0	35.0		36.0	5.0	35.0		36.0				
Max Q Clear Time (g_c+1), s	3.7	7.9		4.5	2.7	7.4		5.3				
Green Ext Time (p_c), s	0.0	5.9		0.4	0.0	5.7		0.6				
Intersection Summary												
HCM 2010 Ctrl Delay				8.7								
HCM 2010 LOS				A								

HCM 2010 Signalized Intersection Summary
 2: SR-111 & Keystone Road

Ex + Total Project + CG PM
 09/06/2018

Movement	EBL	EBT	EBR	WBL	WBT	WBR	NBL	NBT	NBR	SBL	SBT	SBR
Lane Configurations		↕			↕		↖	↗	↖	↗	↖	↗
Traffic Volume (veh/h)	7	8	65	2	10	0	29	422	2	5	755	4
Future Volume (veh/h)	7	8	65	2	10	0	29	422	2	5	755	4
Number	7	4	14	3	8	18	5	2	12	1	6	18
Initial Q (Qb), veh	0	0	0	0	0	0	0	0	0	0	0	0
Ped-Bike Adj(A_pbT)	1.00		1.00	1.00		1.00	1.00		1.00	1.00		1.00
Parking Bus, Adj	1.00	1.00	1.00	1.00	1.00	1.00	1.00	1.00	1.00	1.00	1.00	1.00
Adj Sat Flow, veh/h/ln	1900	1863	1900	1900	1863	1900	1863	1863	1863	1863	1863	1863
Adj Flow Rate, veh/h	8	9	71	2	11	0	32	459	2	5	821	4
Adj No. of Lanes	0	1	0	0	1	0	1	2	1	1	2	1
Peak Hour Factor	0.92	0.92	0.92	0.92	0.92	0.92	0.92	0.92	0.92	0.92	0.92	0.92
Percent Heavy Veh, %	2	2	2	2	2	2	2	2	2	2	2	2
Cap, veh/h	94	16	102	104	130	0	65	2201	985	12	2095	937
Arrive On Green	0.08	0.08	0.08	0.08	0.08	0.00	0.04	0.62	0.62	0.01	0.59	0.59
Sat Flow, veh/h	106	203	1291	175	1647	0	1774	3539	1583	1774	3539	1583
Grp Volume(v), veh/h	88	0	0	13	0	0	32	459	2	5	821	4
Grp Sat Flow(s), veh/h/ln/1600	0	0	1822	0	0	1774	1770	1583	1774	1770	1583	
Q Serve(g_s), s	1.5	0.0	0.0	0.0	0.0	0.0	0.8	2.6	0.0	0.1	5.7	0.0
Cycle Q Clear(g_c), s	2.5	0.0	0.0	0.3	0.0	0.0	0.8	2.6	0.0	0.1	5.7	0.0
Prop In Lane	0.09		0.81	0.15		0.00	1.00		1.00	1.00		1.00
Lane Grp Cap(c), veh/h	211	0	0	233	0	0	65	2201	985	12	2095	937
V/C Ratio(X)	0.42	0.00	0.00	0.06	0.00	0.00	0.49	0.21	0.00	0.42	0.39	0.00
Avail Cap(c_a), veh/h	985	0	0	1086	0	0	504	2201	985	504	2095	937
HCM Platoon Ratio	1.00	1.00	1.00	1.00	1.00	1.00	1.00	1.00	1.00	1.00	1.00	1.00
Upstream Filter(I)	1.00	0.00	0.00	1.00	0.00	0.00	1.00	1.00	1.00	1.00	1.00	1.00
Uniform Delay (d), s/veh	20.7	0.0	0.0	19.7	0.0	0.0	21.8	3.8	3.3	22.8	5.0	3.8
Incr Delay (d2), s/veh	1.3	0.0	0.0	0.1	0.0	0.0	5.7	0.2	0.0	21.7	0.6	0.0
Initial Q Delay(d3),s/veh	0.0	0.0	0.0	0.0	0.0	0.0	0.0	0.0	0.0	0.0	0.0	0.0
%ile BackOfQ(50%),veh/ln/1.2	0.0	0.0	0.0	0.2	0.0	0.0	0.5	1.3	0.0	0.1	2.9	0.0
LnGrp Delay(d),s/veh	22.0	0.0	0.0	19.8	0.0	0.0	27.5	4.0	3.3	44.5	5.5	3.9
LnGrp LOS	C			B			C	A	A	D	A	A
Approach Vol, veh/h	88			13			493			830		
Approach Delay, s/veh	22.0			19.8			5.5			5.8		
Approach LOS	C			B			A			A		
Timer	1	2	3	4	5	6	7	8				
Assigned Phs	1	2	4		5	6	8					
Phs Duration (G+Y+Rc), s/4.8	33.2		8.1	6.2	31.8		8.1					
Change Period (Y+Rc), s 4.5	4.5		4.5	4.5	4.5		4.5					
Max Green Setting (Gmax), s	27.3		26.1	13.1	27.3		26.1					
Max Q Clear Time (g_c+I), s	4.6		4.5	2.8	7.7		2.3					
Green Ext Time (p_c), s	0.0	3.1		0.4	0.0	5.8		0.0				
Intersection Summary												
HCM 2010 Ctrl Delay				6.8								
HCM 2010 LOS				A								

HCM 2010 TWSC
3: SR-86 & Harris Road

Ex + Total Project + CG PM
09/06/2018

Intersection												
Int Delay, s/veh	0.4											
Movement	EBL	EBT	EBR	WBL	WBT	WBR	NBL	NBT	NBR	SBL	SBT	SBR
Lane Configurations		↔			↔			↕↕			↕↕	
Traffic Vol, veh/h	0	0	0	8	2	5	0	727	8	10	709	0
Future Vol, veh/h	0	0	0	8	2	5	0	727	8	10	709	0
Conflicting Peds, #/hr	0	0	0	0	0	0	0	0	0	0	0	0
Sign Control	Stop	Stop	Stop	Stop	Stop	Stop	Free	Free	Free	Free	Free	Free
RT Channelized	-	-	None	-	-	None	-	-	None	-	-	None
Storage Length	-	-	-	-	-	-	-	-	-	-	-	-
Veh In Median Storage, #	-	-	-	-	0	-	-	0	-	-	0	-
Grade, %	-	0	-	-	0	-	-	0	-	-	0	-
Peak Hour Factor	92	92	92	92	92	92	92	92	92	92	92	92
Heavy Vehicles, %	2	2	2	2	2	2	2	2	2	2	2	2
Mvmt Flow	0	0	0	9	2	5	0	790	9	11	771	0

Major/Minor	Minor2		Minor1			Major1		Major2				
Conflicting Flow All	1189	1592	386	1203	1588	400	771	0	0	799	0	0
Stage 1	793	793	-	795	795	-	-	-	-	-	-	-
Stage 2	396	799	-	408	793	-	-	-	-	-	-	-
Critical Hdwy	7.54	6.54	6.94	7.54	6.54	6.94	4.14	-	-	4.14	-	-
Critical Hdwy Stg 1	6.54	5.54	-	6.54	5.54	-	-	-	-	-	-	-
Critical Hdwy Stg 2	6.54	5.54	-	6.54	5.54	-	-	-	-	-	-	-
Follow-up Hdwy	3.52	4.02	3.32	3.52	4.02	3.32	2.22	-	-	2.22	-	-
Pot Cap-1 Maneuver	143	106	612	140	107	600	840	-	-	819	-	-
Stage 1	348	398	-	347	398	-	-	-	-	-	-	-
Stage 2	601	396	-	591	398	-	-	-	-	-	-	-
Platoon blocked, %	-	-	-	-	-	-	-	-	-	-	-	-
Mov Cap-1 Maneuver	137	104	612	137	105	600	840	-	-	819	-	-
Mov Cap-2 Maneuver	137	104	-	137	105	-	-	-	-	-	-	-
Stage 1	348	398	-	347	398	-	-	-	-	-	-	-
Stage 2	592	396	-	577	389	-	-	-	-	-	-	-

Approach	EB	WB	NB	SB
HCM Control Delay, s	0	27.7	0	0.2
HCM LOS	A	D		

Minor Lane/Major Mvmt	NBL	NBT	NBR	EBLn1	WBLn1	SBL	SBT	SBR
Capacity (veh/h)	840	-	-	-	175	819	-	-
HCM Lane V/C Ratio	-	-	-	-	0.093	0.013	-	-
HCM Control Delay (s)	0	-	-	0	27.7	9.5	0.1	-
HCM Lane LOS	A	-	-	A	D	A	A	-
HCM 95th %ile Q(veh)	0	-	-	-	0.3	0	-	-

HCM 2010 Signalized Intersection Summary
4: Harris Road & Dogwood Rd

Ex + Total Project + CG PM
09/06/2018

	↖	→	↗	↖	←	↖	↗	↑	↖	↗	↓	↖
Movement	EBL	EBT	EBR	WBL	WBT	WBR	NBL	NBT	NBR	SBL	SBT	SBR
Lane Configurations		↕			↕			↕			↕	
Traffic Volume (veh/h)	1	18	4	12	9	2	0	143	1	5	242	9
Future Volume (veh/h)	1	18	4	12	9	2	0	143	1	5	242	9
Number	7	4	14	3	8	18	5	2	12	1	6	16
Initial Q (Qb), veh	0	0	0	0	0	0	0	0	0	0	0	0
Ped-Bike Adj(A_pbT)	1.00		1.00	1.00		1.00	1.00		1.00	1.00		1.00
Parking Bus, Adj	1.00	1.00	1.00	1.00	1.00	1.00	1.00	1.00	1.00	1.00	1.00	1.00
Adj Sat Flow, veh/h/ln	1900	1863	1900	1900	1863	1900	1900	1863	1900	1900	1863	1900
Adj Flow Rate, veh/h	1	20	4	13	10	2	0	155	1	5	263	10
Adj No. of Lanes	0	1	0	0	1	0	0	1	0	0	1	0
Peak Hour Factor	0.92	0.92	0.92	0.92	0.92	0.92	0.92	0.92	0.92	0.92	0.92	0.92
Percent Heavy Veh, %	2	2	2	2	2	2	2	2	2	2	2	2
Cap, veh/h	88	602	116	413	293	51	0	739	5	85	709	27
Arrive On Green	0.40	0.40	0.40	0.40	0.40	0.40	0.00	0.40	0.40	0.40	0.40	0.40
Sat Flow, veh/h	13	1505	289	727	733	127	0	1849	12	8	1772	66
Grp Volume(v), veh/h	25	0	0	25	0	0	0	0	156	278	0	0
Grp Sat Flow(s), veh/h/ln	1807	0	0	1587	0	0	0	0	1861	1847	0	0
Q Serve(g_s), s	0.0	0.0	0.0	0.0	0.0	0.0	0.0	0.0	2.5	0.0	0.0	0.0
Cycle Q Clear(g_c), s	0.4	0.0	0.0	0.4	0.0	0.0	0.0	0.0	2.5	4.8	0.0	0.0
Prop In Lane	0.04		0.16	0.52		0.08	0.00		0.01	0.02		0.04
Lane Grp Cap(c), veh/h	806	0	0	756	0	0	0	0	744	820	0	0
V/C Ratio(X)	0.03	0.00	0.00	0.03	0.00	0.00	0.00	0.00	0.21	0.34	0.00	0.00
Avail Cap(c_a), veh/h	806	0	0	756	0	0	0	0	744	820	0	0
HCM Platoon Ratio	1.00	1.00	1.00	1.00	1.00	1.00	1.00	1.00	1.00	1.00	1.00	1.00
Upstream Filter(I)	1.00	0.00	0.00	1.00	0.00	0.00	0.00	0.00	1.00	1.00	0.00	0.00
Uniform Delay (d), s/veh	8.2	0.0	0.0	8.2	0.0	0.0	0.0	0.0	8.8	9.5	0.0	0.0
Incr Delay (d2), s/veh	0.1	0.0	0.0	0.1	0.0	0.0	0.0	0.0	0.6	1.1	0.0	0.0
Initial Q Delay(d3),s/veh	0.0	0.0	0.0	0.0	0.0	0.0	0.0	0.0	0.0	0.0	0.0	0.0
%ile BackOfQ(50%),veh/ln	0.2	0.0	0.0	0.2	0.0	0.0	0.0	0.0	1.4	2.6	0.0	0.0
LnGrp Delay(d),s/veh	8.3	0.0	0.0	8.3	0.0	0.0	0.0	0.0	9.5	10.7	0.0	0.0
LnGrp LOS	A			A					A	B		
Approach Vol, veh/h		25			25			156			278	
Approach Delay, s/veh		8.3			8.3			9.5			10.7	
Approach LOS		A			A			A			B	
Timer	1	2	3	4	5	6	7	8				
Assigned Phs		2		4		6		8				
Phs Duration (G+Y+Rc), s		22.5		22.5		22.5		22.5				
Change Period (Y+Rc), s		4.5		4.5		4.5		4.5				
Max Green Setting (Gmax), s		18.0		18.0		18.0		18.0				
Max Q Clear Time (g_c+1), s		4.5		2.4		6.8		2.4				
Green Ext Time (p_c), s		0.6		0.0		1.2		0.0				
Intersection Summary												
HCM 2010 Ctrl Delay				10.0								
HCM 2010 LOS				B								

HCM 2010 Signalized Intersection Summary
5: SR-111 & Harris Road

Ex + Total Project + CG PM
09/06/2018

	↖	→	↗	↖	←	↗	↖	↑	↗	↖	↓	↗
Movement	EBL	EBT	EBR	WBL	WBT	WBR	NBL	NBT	NBR	SBL	SBT	SBR
Lane Configurations		↕			↕		↕	↕	↕	↕	↕	↕
Traffic Volume (veh/h)	4	12	6	1	11	5	13	347	0	0	719	5
Future Volume (veh/h)	4	12	6	1	11	5	13	347	0	0	719	5
Number	7	4	14	3	8	18	5	2	12	1	6	16
Initial Q (Qb), veh	0	0	0	0	0	0	0	0	0	0	0	0
Ped-Bike Adj(A_pbT)	1.00		1.00	1.00		1.00	1.00		1.00	1.00		1.00
Parking Bus, Adj	1.00	1.00	1.00	1.00	1.00	1.00	1.00	1.00	1.00	1.00	1.00	1.00
Adj Sat Flow, veh/h/ln	1900	1863	1900	1900	1863	1900	1863	1863	1863	1863	1863	1863
Adj Flow Rate, veh/h	4	13	7	1	12	5	14	377	0	0	782	5
Adj No. of Lanes	0	1	0	0	1	0	1	2	1	1	2	1
Peak Hour Factor	0.92	0.92	0.92	0.92	0.92	0.92	0.92	0.92	0.92	0.92	0.92	0.92
Percent Heavy Veh, %	2	2	2	2	2	2	2	2	2	2	2	2
Cap, veh/h	94	41	22	78	52	22	31	2768	1238	3	2397	1072
Arrive On Green	0.04	0.04	0.04	0.04	0.04	0.04	0.02	0.78	0.00	0.00	0.68	0.68
Sat Flow, veh/h	286	930	501	93	1188	492	1774	3539	1583	1774	3539	1583
Grp Volume(v), veh/h	24	0	0	18	0	0	14	377	0	0	782	5
Grp Sat Flow(s),veh/h/ln	1717	0	0	1773	0	0	1774	1770	1583	1774	1770	1583
Q Serve(g_s), s	0.2	0.0	0.0	0.0	0.0	0.0	0.4	1.3	0.0	0.0	4.7	0.1
Cycle Q Clear(g_c), s	0.7	0.0	0.0	0.5	0.0	0.0	0.4	1.3	0.0	0.0	4.7	0.1
Prop In Lane	0.17		0.29	0.06		0.28	1.00		1.00	1.00		1.00
Lane Grp Cap(c), veh/h	156	0	0	151	0	0	31	2768	1238	3	2397	1072
V/C Ratio(X)	0.15	0.00	0.00	0.12	0.00	0.00	0.45	0.14	0.00	0.00	0.33	0.00
Avail Cap(c_a), veh/h	1254	0	0	1290	0	0	172	2768	1238	172	2397	1072
HCM Platoon Ratio	1.00	1.00	1.00	1.00	1.00	1.00	1.00	1.00	1.00	1.00	1.00	1.00
Upstream Filter(I)	1.00	0.00	0.00	1.00	0.00	0.00	1.00	1.00	0.00	0.00	1.00	1.00
Uniform Delay (d), s/veh	23.9	0.0	0.0	23.9	0.0	0.0	25.1	1.4	0.0	0.0	3.5	2.7
Incr Delay (d2), s/veh	0.4	0.0	0.0	0.3	0.0	0.0	9.7	0.1	0.0	0.0	0.4	0.0
Initial Q Delay(d3),s/veh	0.0	0.0	0.0	0.0	0.0	0.0	0.0	0.0	0.0	0.0	0.0	0.0
%ile BackOfQ(50%),veh/ln	0.4	0.0	0.0	0.3	0.0	0.0	0.3	0.7	0.0	0.0	2.4	0.0
LnGrp Delay(d),s/veh	24.4	0.0	0.0	24.2	0.0	0.0	34.8	1.5	0.0	0.0	3.8	2.7
LnGrp LOS	C			C			C	A			A	A
Approach Vol, veh/h		24			18			391			787	
Approach Delay, s/veh		24.4			24.2			2.7			3.8	
Approach LOS		C			C			A			A	
Timer	1	2	3	4	5	6	7	8				
Assigned Phs	1	2		4	5	6		8				
Phs Duration (G+Y+Rc), s	0.0	44.9		6.8	5.4	39.5		6.8				
Change Period (Y+Rc), s	4.5	4.5		4.5	4.5	4.5		4.5				
Max Green Setting (Gmax), s	35.0			36.0	5.0	35.0		36.0				
Max Q Clear Time (g_c+1), s	3.3			2.7	2.4	6.7		2.5				
Green Ext Time (p_c), s	0.0	2.7		0.1	0.0	6.1		0.1				
Intersection Summary												
HCM 2010 Ctrl Delay				4.2								
HCM 2010 LOS				A								

HCM 2010 Signalized Intersection Summary
6: SR-86 & Worthington Road

Ex + Total Project + CG PM
09/06/2018

Movement	EBL	EBT	EBR	WBL	WBT	WBR	NBL	NBT	NBR	SBL	SBT	SBR
Lane Configurations		↔	↔		↔	↔	↔	↔	↔	↔	↔	↔
Traffic Volume (veh/h)	54	106	137	70	162	72	145	852	26	37	674	86
Future Volume (veh/h)	54	106	137	70	162	72	145	852	28	37	674	86
Number	7	4	14	3	8	18	5	2	12	1	6	16
Initial Q (Qb), veh	0	0	0	0	0	0	0	0	0	0	0	0
Ped-Bike Adj(A_pbT)	1.00		1.00	1.00		1.00	1.00		1.00	1.00		1.00
Parking Bus, Adj	1.00	1.00	1.00	1.00	1.00	1.00	1.00	1.00	1.00	1.00	1.00	1.00
Adj Sat Flow, veh/h/ln	1900	1863	1863	1900	1863	1863	1863	1863	1900	1863	1863	1900
Adj Flow Rate, veh/h	59	115	149	76	176	78	158	926	28	40	733	93
Adj No. of Lanes	0	1	1	0	1	1	1	2	0	1	2	0
Peak Hour Factor	0.92	0.92	0.92	0.92	0.92	0.92	0.92	0.92	0.92	0.92	0.92	0.92
Percent Heavy Veh, %	2	2	2	2	2	2	2	2	2	2	2	2
Cap, veh/h	78	152	199	91	211	260	192	1642	50	63	1251	159
Arrive On Green	0.13	0.13	0.13	0.16	0.16	0.16	0.11	0.47	0.47	0.04	0.40	0.40
Sat Flow, veh/h	621	1211	1583	553	1282	1583	1774	3508	106	1774	3161	401
Grp Volume(v), veh/h	174	0	149	252	0	78	158	467	487	40	410	416
Grp Sat Flow(s),veh/h/ln	1832	0	1583	1835	0	1583	1774	1770	1844	1774	1770	1792
Q Serve(g_s), s	8.0	0.0	7.9	11.6	0.0	3.8	7.6	16.6	16.6	1.9	15.9	15.9
Cycle Q Clear(g_c), s	8.0	0.0	7.9	11.6	0.0	3.8	7.6	16.6	16.6	1.9	15.9	15.9
Prop In Lane	0.34		1.00	0.30		1.00	1.00		0.06	1.00		0.22
Lane Grp Cap(c), veh/h	230	0	199	302	0	260	192	829	863	63	700	709
V/C Ratio(X)	0.76	0.00	0.75	0.84	0.00	0.30	0.82	0.56	0.56	0.63	0.59	0.59
Avail Cap(c_a), veh/h	389	0	336	389	0	336	214	829	863	144	700	709
HCM Platoon Ratio	1.00	1.00	1.00	1.00	1.00	1.00	1.00	1.00	1.00	1.00	1.00	1.00
Upstream Filter(I)	1.00	0.00	1.00	1.00	0.00	1.00	1.00	1.00	1.00	1.00	1.00	1.00
Uniform Delay (d), s/veh	36.8	0.0	36.8	35.3	0.0	32.0	38.1	16.8	16.8	41.5	20.7	20.7
Incr Delay (d2), s/veh	5.0	0.0	5.6	11.7	0.0	0.6	20.6	2.8	2.7	10.0	3.6	3.5
Initial Q Delay(d3),s/veh	0.0	0.0	0.0	0.0	0.0	0.0	0.0	0.0	0.0	0.0	0.0	0.0
%ile BackOfQ(50%),veh/ln	4	0.0	3.8	6.9	0.0	1.7	4.8	8.7	9.0	1.1	8.4	8.5
LnGrp Delay(d),s/veh	41.9	0.0	42.4	47.0	0.0	32.7	58.7	19.5	19.4	51.5	24.3	24.3
LnGrp LOS	D		D	D		C	E	B	B	D	C	C
Approach Vol, veh/h		323			330			1112			866	
Approach Delay, s/veh		42.1			43.6			25.0			25.5	
Approach LOS		D			D			C			C	
Timer	1	2	3	4	5	6	7	8				
Assigned Phs	1	2		4	5	6		8				
Phs Duration (G+Y+Rc), s	7.6	45.3		15.4	13.9	39.0		18.8				
Change Period (Y+Rc), s	4.5	4.5		4.5	4.5	4.5		4.5				
Max Green Setting (Gmax), s	37.9			18.5	10.5	34.5		18.5				
Max Q Clear Time (g_c+I), s	18.6			10.0	9.6	17.9		13.6				
Green Ext Time (p_c), s	0.0	6.2		0.9	0.0	4.9		0.7				
Intersection Summary												
HCM 2010 Ctrl Delay			29.6									
HCM 2010 LOS			C									

HCM 2010 Signalized Intersection Summary
 7: SR-111 & Worthington Rd

Ex + Total Project + CG PM
 09/06/2018

Movement	EBL	EBT	EBR	WBL	WBT	WBR	NBL	NBT	NBR	SBL	SBT	SBR
Lane Configurations		↕			↕		↕	↕	↕	↕	↕	↕
Traffic Volume (veh/h)	26	47	53	7	41	8	54	321	4	16	638	41
Future Volume (veh/h)	26	47	53	7	41	8	54	321	4	16	638	41
Number	7	4	14	3	8	18	5	2	12	1	6	16
Initial Q (Qb), veh	0	0	0	0	0	0	0	0	0	0	0	0
Ped-Bike Adj(A_pbT)	1.00		1.00	1.00		1.00	1.00		1.00	1.00		1.00
Parking Bus, Adj	1.00	1.00	1.00	1.00	1.00	1.00	1.00	1.00	1.00	1.00	1.00	1.00
Adj Sat Flow, veh/h/ln	1900	1863	1900	1900	1863	1900	1863	1863	1863	1863	1863	1863
Adj Flow Rate, veh/h	28	51	58	8	45	9	59	349	0	17	693	0
Adj No. of Lanes	0	1	0	0	1	0	1	2	1	1	2	1
Peak Hour Factor	0.92	0.92	0.92	0.92	0.92	0.92	0.92	0.92	0.92	0.92	0.92	0.92
Percent Heavy Veh, %	2	2	2	2	2	2	2	2	2	2	2	2
Cap, veh/h	116	89	66	96	174	32	99	2066	924	37	1942	869
Arrive On Green	0.12	0.12	0.12	0.12	0.12	0.12	0.06	0.58	0.00	0.02	0.55	0.00
Sat Flow, veh/h	232	720	699	118	1409	259	1774	3539	1583	1774	3539	1583
Grp Volume(v), veh/h	137	0	0	62	0	0	59	349	0	17	693	0
Grp Sat Flow(s),veh/h/ln	1650	0	0	1785	0	0	1774	1770	1583	1774	1770	1583
Q Serve(g_s), s	2.1	0.0	0.0	0.0	0.0	0.0	1.6	2.3	0.0	0.5	5.5	0.0
Cycle Q Clear(g_c), s	3.9	0.0	0.0	1.5	0.0	0.0	1.6	2.3	0.0	0.5	5.5	0.0
Prop In Lane	0.20		0.42	0.13		0.15	1.00		1.00	1.00		1.00
Lane Grp Cap(c), veh/h	291	0	0	303	0	0	99	2066	924	37	1942	869
V/C Ratio(X)	0.47	0.00	0.00	0.20	0.00	0.00	0.59	0.17	0.00	0.46	0.36	0.00
Avail Cap(c_a), veh/h	939	0	0	991	0	0	467	2066	924	467	1942	869
HCM Platoon Ratio	1.00	1.00	1.00	1.00	1.00	1.00	1.00	1.00	1.00	1.00	1.00	1.00
Upstream Filter(I)	1.00	0.00	0.00	1.00	0.00	0.00	1.00	1.00	0.00	1.00	1.00	0.00
Uniform Delay (d), s/veh	20.8	0.0	0.0	19.8	0.0	0.0	22.9	4.8	0.0	24.1	6.3	0.0
Incr Delay (d2), s/veh	1.2	0.0	0.0	0.3	0.0	0.0	5.5	0.2	0.0	8.4	0.5	0.0
Initial Q Delay(d3),s/veh	0.0	0.0	0.0	0.0	0.0	0.0	0.0	0.0	0.0	0.0	0.0	0.0
%ile BackOfQ(50%),veh/ln	1.9	0.0	0.0	0.8	0.0	0.0	0.9	1.1	0.0	0.3	2.7	0.0
LnGrp Delay(d),s/veh	21.9	0.0	0.0	20.1	0.0	0.0	28.5	5.0	0.0	32.5	6.8	0.0
LnGrp LOS	C			C			C	A		C	A	
Approach Vol, veh/h	137			62			408			710		
Approach Delay, s/veh	21.9			20.1			8.4			7.4		
Approach LOS	C			C			A			A		
Timer	1	2	3	4	5	6	7	8				
Assigned Phs	1	2		4	5	6		8				
Phs Duration (G+Y+Rc), s	5.5	33.5		10.7	7.3	31.8		10.7				
Change Period (Y+Rc), s	4.5	4.5		4.5	4.5	4.5		4.5				
Max Green Setting (Gmax), s	27.3			26.1	13.1	27.3		26.1				
Max Q Clear Time (g_c+I), s	4.3			5.9	3.6	7.5		3.5				
Green Ext Time (p_c), s	0.0	2.3		0.7	0.1	4.7		0.2				
Intersection Summary												
HCM 2010 Ctrl Delay				9.8								
HCM 2010 LOS				A								

Geotechnical Report (2018 Update)

EEC ORIGINAL PKG

Geotechnical Report – 2018 Update

**Proposed JR Simplot Fertilizer Terminal
NWC Harris Road and UPRR Tracks
Brawley, California**

Prepared for:

**JR Simplot
302 Danenberg Drive
El Centro, CA 92243**



Prepared by:



**Landmark Consultants, Inc.
780 N. 4th Street
El Centro, CA 92243
(760) 337-1100**

December 2018

EEC ORIGINAL PKG



780 N. 4th Street
El Centro, CA 92243
(760) 370-3000
landmark@landmark-ca.com

77-948 Wildcat Drive
Palm Desert, CA 92211
(760) 360-0665
gchandra@landmark-ca.com

December 4, 2018

Mr. Gary L. Smith
JR Simplot
302 Danenberg Drive
El Centro, CA 92243

**Geotechnical Report – 2018 Update
Proposed JR Simplot Fertilizer Terminal
NWC Harris Road and UPRR Tracks
Brawley, California
LCI Report No. LE18215**

Dear Mr. Smith:

This geotechnical report update is provided for design and construction of the proposed JR Simplot Fertilizer Terminal located north of Harris Road along the west side of the Union Pacific Railroad tracks south of Brawley, California. The enclosed report describes our review of the original geotechnical report and soil engineering site evaluation and presents our professional opinions regarding geotechnical conditions at the site to be considered in the design and construction of the project. The 2007 geotechnical report is provided in Appendix D of this report.

This executive summary presents *selected* elements of our findings and professional opinions. This summary *may not* present all details needed for the proper application of our findings and professional opinions. Our findings, professional opinions, and application options are *best related through reading the full report*, and are best evaluated with the active participation of the engineer of record who developed them. The findings of this study are summarized below:

- Clay soils (CL) of medium to high expansion predominate the site.
- Foundation designs should mitigate expansive soil conditions by one of the following methods:
 1. Remove and replace upper 3.0 feet of clay soils with non-expansive sands.
 2. Design foundations to resist expansive forces in accordance with the 2016 California Building Code (CBC) Chapter 18, Section 1808 or the Post-Tensioning Institute, 3rd Edition. This requires grade-beam stiffened or floor slabs (18 feet maximum on center) or post-tensioned floor slabs. Design soil bearing pressure = 1,500 psf. Differential movement of 1.0 to 1.5 inches can be expected for slab on grade foundations placed on clay soils.
 3. A combination of the methods described above.

EEC ORIGINAL PKG

- The risk of liquefaction induced settlement is low (estimated settlement of ½ inch at 10.5 to 50 feet below ground surface). There is a very low risk of ground rupture should liquefaction occur.
- The site is located approximately 1.2 miles from a major fault (Imperial Fault) with potential of a magnitude 7 event. Strong groundshaking will occur at this site and special structural designs will be required.
- The clay soils are aggressive to concrete and steel. Concrete mixes for concrete placed in contact with native soils shall have a maximum water cement ratio of 0.45 and a minimum compressive strength of 4,500 psi (minimum of 6 sacks Type V cement per cubic yard).
- All reinforcing bars, anchor bolts and hold down bolts shall have a minimum concrete cover of 3.0 inches unless epoxy coated (ASTM D3963/A934). Hold-down straps are not allowed at the foundation perimeter. No pressurized water lines are allowed below or within the foundations.
- The clay soils are non-absorptive and are not suitable for onsite sewage disposal systems or for infiltration in stormwater basins.
- Pavement structural sections should be designed for clay subgrade soils (R-Value = 5).

We did not encounter soil conditions that would preclude development of the proposed project provided the professional opinions contained in this report are considered in the design and construction of this project.

We appreciate the opportunity to provide our findings and professional opinions regarding geotechnical conditions at the site. Please provide our office with a set of the foundation plans and civil plans for review to insure that the geotechnical site constraints have been included in the design documents. If you have any questions or comments regarding our findings, please call our office at (760) 370-3000.

Respectfully Submitted,
Landmark Consultants, Inc.

Steven K. Williams, PG, EG
Senior Engineering Geologist



Jeffrey O. Lyon, PE
President



TABLE OF CONTENTS

	Page
Section 1.....	1
INTRODUCTION	1
1.1 Project Description.....	1
1.2 Purpose and Scope of Work.....	1
1.3 Authorization	3
Section 2.....	4
METHODS OF INVESTIGATION	4
2.1 Field Exploration	4
2.2 Laboratory Testing.....	6
Section 3.....	7
DISCUSSION	7
3.1 Site Conditions.....	7
3.2 Geologic Setting.....	7
3.3 Subsurface Soil	8
3.4 Groundwater	9
3.5 Faulting	10
3.6 General Ground Motion Analysis.....	11
3.7 Seismic and Other Hazards.....	11
3.8 Liquefaction	12
Section 4.....	15
DESIGN CRITERIA	15
4.1 Site Preparation.....	15
4.2 Utility Trench Backfill.....	18
4.3 Spread Footing Foundations and Settlements.....	19
4.4 Steel Tank Foundations and Settlements	22
4.5 Slabs-On-Grade.....	24
4.6 Concrete Mixes and Corrosivity	26
4.7 Excavations.....	28
4.8 Lateral Earth Pressures	29
4.9 Seismic Design.....	30
4.10 Soil Erosion Factors for SWPPP Plans.....	30
4.11 Railroad Spur Line Subgrade Preparation	31
4.12 Pavements	31
Section 5.....	33
LIMITATIONS AND ADDITIONAL SERVICES	33
5.1 Limitations	33
5.2 Additional Services.....	34

Appendices

- APPENDIX A: Vicinity and Site Maps**
- APPENDIX B: Liquefaction Analysis**
- APPENDIX C: References**
- APPENDIX D: 2007 Geotechnical Report**

Section 1
INTRODUCTION

1.1 Project Description

This report presents the findings of our review of the 2007 geotechnical exploration and soil testing by Landmark for the proposed JR Simplot Fertilizer Terminal located on the 40 acre agricultural field north of Harris Road along the west side of the Union Pacific Railroad tracks and Newside Drain No. 1 north of Imperial, California (See Vicinity Map, Plate A-1). The proposed development will consist of several large liquid fertilizer tanks and two large dry fertilizer warehouse buildings. Also, the proposed facility will have an administration office, truck scale, and associated internal roadways. A new rail spur is planned to be located along the north side of the project site.

The office building is planned to consist of slab-on-grade foundation with masonry and/or wood-frame concrete construction. Footing loads at exterior bearing walls are estimated at 1 to 5 kips per lineal foot. The warehouses are planned to consist of slab-on-grade foundation with masonry and/or steel-frame construction. Footing loads at exterior bearing walls are estimated at 1 to 5 kips per lineal foot. Column loads are estimated to range from 5 to 100 kips. The dimensions for the proposed steel storage tanks were not provided at the time that this report was prepared. The estimated loads imposed at ground surface by the loaded tanks have been estimated to range from 1,000 to 4,000 pounds per square foot.

If structural loads exceed those stated above, we should be notified so we may evaluate their impact on foundation settlement and bearing capacity. Site development will include deep foundation installations, building support pad preparation, underground utility installation, roadway and concrete flatwork placement.

1.2 Purpose and Scope of Work

The purpose of this geotechnical report update was to review the subsurface soil at selected locations within the site, evaluation of physical/engineering properties of the site soils, and liquefaction potential during seismic events.

Professional opinions were developed from field and laboratory test data and are provided in this report regarding geotechnical conditions at this site and the effect on design and construction. The scope of our services consisted of the following:

- ▶ Field exploration and in-situ testing of the site soils at selected locations and depths.
- ▶ Laboratory testing for physical and/or chemical properties of selected samples.
- ▶ Review of the available literature and publications pertaining to local geology, faulting, and seismicity.
- ▶ Engineering analysis and evaluation of the data collected.
- ▶ Preparation of this report presenting our findings and professional opinions regarding the geotechnical aspects of project design and construction.

This report addresses the following geotechnical parameters:

- ▶ Subsurface soil and groundwater conditions
- ▶ Site geology, regional faulting and seismicity, near source factors, and site seismic accelerations
- ▶ Liquefaction potential and its mitigation
- ▶ Expansive soil and methods of mitigation
- ▶ Aggressive soil conditions to metals and concrete

Professional opinions with regard to the above parameters are provided for the following:

- ▶ Site grading and earthwork
- ▶ Building pad and foundation subgrade preparation
- ▶ Allowable soil bearing pressures and expected settlements
- ▶ Concrete slabs-on-grade
- ▶ Lateral earth pressures
- ▶ Excavation conditions and buried utility installations
- ▶ Mitigation of the potential effects of salt concentrations in native soil to concrete mixes and steel reinforcement
- ▶ Seismic design parameters
- ▶ Pavement structural sections

Our scope of work for this report did not include additional field or laboratory evaluation of the site.

1.3 Authorization

Mr. Gary Smith of JR Simplot provided authorization by written agreement to proceed with our work on November 15, 2018. We conducted our work according to our written proposal dated November 15, 2018.

Section 2
METHODS OF INVESTIGATION

2.1 Field Exploration

The subsurface exploration for the 2007 report was performed on November 19, 2007 using Holguin, Fahan, & Associates, Inc. of Cypress, California to advance four (4) electric cone penetrometer (CPT) soundings to an approximate depth of 50 feet below existing ground surface. The soundings were made at the locations shown on the Site and Exploration Plan (Plate A-2). The approximate sounding locations were established in the field and plotted on the site map by sighting to discernable site features.

CPT soundings provide a continuous profile of the soil stratigraphy with readings every 2.5cm (1 inch) in depth. Direct sampling for visual and physical confirmation of soil properties has been used by our firm to establish direct correlations with CPT exploration in this geographical region.

The CPT exploration was conducted by hydraulically advancing an instrumented Hogentogler 10cm² conical probe into the ground at a rate of 2cm per second using a 23-ton truck as a reaction mass. An electronic data acquisition system recorded a nearly continuous log of the resistance of the soil against the cone tip (Q_c) and soil friction against the cone sleeve (F_s) as the probe was advanced. Empirical relationships (Robertson and Campanella, 1989) were then applied to the data to give a continuous profile of the soil stratigraphy. Interpretation of CPT data provides correlations for SPT blow count, phi (ϕ) angle (soil friction angle), undrained shear strength (S_u) of clays and over-consolidation ratio (OCR). These correlations may then be used to evaluate vertical and lateral soil bearing capacities and consolidation characteristics of the subsurface soil.

Additional subsurface exploration was performed on November 20, 2007 using 2R Drilling of Ontario, California to advance eight (8) borings to depths of 5 to 51.5 feet below existing ground surface. The borings were advanced with a truck-mounted, CME 55 drill rig using 8-inch diameter, hollow-stem, continuous-flight augers. The approximate boring locations were established in the field and plotted on the site map by sighting to discernable site features. The boring locations are shown on the Site and Exploration Plan (Plate A-2).

A staff engineer observed the drilling operations and maintained a log of the soil encountered and sampling depths, visually classified the soil encountered during drilling in accordance with the Unified Soil Classification System, and obtained drive tube and bulk samples of the subsurface materials at selected intervals. Relatively undisturbed soil samples were retrieved using a 2-inch outside diameter (OD) split-spoon sampler or a 3-inch OD Modified California Split-Barrel (ring) sampler. The samples were obtained by driving the sampler ahead of the auger tip at selected depths. The drill rig was equipped with a 140-pound CME automatic hammer for conducting Standard Penetration Tests (SPT). The number of blows required to drive the samplers 12 inches into the soil is recorded on the boring logs as “blows per foot”. Blow counts reported on the boring logs represent the field blow counts. No corrections have been applied for effects of overburden pressure, automatic hammer drive energy, drill rod lengths, liners, and sampler diameter. Pocket penetrometer readings were also obtained to evaluate the stiffness of cohesive soils retrieved from sampler barrels.

After logging and sampling the soil, the exploratory borings were backfilled with the excavated material. The backfill was loosely placed and was not compacted to the requirements specified for engineered fill.

The subsurface borings logs and interpretive logs of the CPT soundings are presented on Plates B-1 through B-12 in Appendix B (Appendix D of this report). A key to the interpretation of CPT soundings and the borings logs are presented on Plates B-13 and B-14, respectively. The stratification lines shown on the subsurface logs represent the approximate boundaries between the various strata. However, the transition from one stratum to another may be gradual over some range of depth.

2.2 Laboratory Testing

Laboratory tests were conducted on selected bulk (auger cuttings) and relatively undisturbed soil samples obtained in thin-wall tubes from the soil boring to aid in classification and evaluation of selected engineering properties of the site soils. The tests were conducted in general conformance to the procedures of the American Society for Testing and Materials (ASTM) or other standardized methods as referenced below. The laboratory testing program consisted of the following tests:

- ▶ Plasticity Index (ASTM D4318) – used for soil classification, settlement estimates and expansive soil design criteria.
- ▶ Particle Size Analyses (ASTM D422) – used for soil classification and liquefaction evaluation
- ▶ Unit Dry Densities (ASTM D2937) and Moisture Contents (ASTM D2216) – used for insitu soil parameters.
- ▶ One Dimensional Consolidation (ASTM D2435) – used for settlement estimates.
- ▶ Unconfined Compression (ASTM D2166) – used for soil strength estimates.
- ▶ R Value (ASTM D2844) – used for pavement structural section design
- ▶ Chemical Analyses (soluble sulfates & chlorides, pH, and resistivity) (Caltrans Methods) – used for concrete mix evaluations and corrosion protection requirements.

The laboratory test results are presented on the subsurface logs in Appendix B and on Plates C-1 through C-8 in Appendix C (Appendix D of this report).

Engineering parameters of soil strength, compressibility and relative density utilized for developing design criteria provided within this report were either extrapolated from correlations with the subsurface CPT data or from data obtained from the field and laboratory testing program.

Section 3 DISCUSSION

3.1 Site Conditions

At the time of the 2007 report, the project site was vacant, flat-lying with Sudan grass stubble covering the site and consists of approximately 40-acres of agricultural land. The project site is trapezoidal in plan view with the east side of the site angled to the northeast along the Newside Drain No. 1. The site is bounded on the south by Harris Road, a paved two-lane rural road (planned as a 4 to 6 lane county arterial) and the east by the Newside Drain, an earthen agricultural runoff water drainage ditch. The Newside Drain is approximately 8 feet deep. A concrete irrigation ditch is located along the north side of the site and a small earthen irrigation ditch is located on the west side of the site. The Spreckles Sugar sugar beet refining facility is located approximately ¼-mile north of the site. Agricultural fields are located to the north, south, east and west sides of the proposed project property.

The project site lies at an elevation of approximately 80 feet below mean sea level (El. 920 local datum) in the Imperial Valley region of the California low desert. The surrounding properties lie on terrain which is flat (planar), part of a large agricultural valley, which was previously an ancient lake bed covered with fresh water to an elevation of 43± feet above MSL. Annual rainfall in this arid region is less than 3 inches per year with four months of average summertime temperatures above 100 °F. Winter temperatures are mild, seldom reaching freezing.

3.2 Geologic Setting

The project site is located in the Imperial Valley portion of the Salton Trough physiographic province. The Salton Trough is a topographic and geologic structural depression resulting from large scale regional faulting. The trough is bounded on the northeast by the San Andreas Fault and Chocolate Mountains and the southwest by the Peninsular Range and faults of the San Jacinto Fault Zone. The Salton Trough represents the northward extension of the Gulf of California, containing both marine and non-marine sediments deposited since the Miocene Epoch (Morton, 1977). Tectonic activity that formed the trough continues at a high rate as evidenced by deformed young sedimentary deposits and high levels of seismicity. Figure 1 shows the location of the site in relation to regional faults and physiographic features.

The Imperial Valley is directly underlain by lacustrine deposits, which consist of interbedded lenticular and tabular silt, sand, and clay. The Late Pleistocene to Holocene (present) lake deposits are probably less than 100 feet thick and derived from periodic flooding of the Colorado River which intermittently formed a fresh water lake (Lake Cahuilla). Older deposits consist of Miocene to Pleistocene non-marine and marine sediments deposited during intrusions of the Gulf of California. Basement rock consisting of Mesozoic granite and Paleozoic metamorphic rocks are estimated to exist at depths between 15,000 - 20,000 feet.

3.3 Subsurface Soil

The U. S. Soil Conservation Service compiled a map of surface soil conditions based on a thirteen-year study from 1962-1975 (Zimmerman, 1981). The Soil Survey maps were published in 1981 and indicate that surficial deposits at the project site and surrounding area consist predominantly of silty clay and silty clay loams of the Holtville and Imperial soil groups (see Plate A-3). These loams are formed in sediment and alluvium of mixed origin (Colorado River overflows and fresh-water lake-bed sediments).

Subsurface soils encountered during the field exploration conducted on November 19 and 20, 2007 consist of dominantly stiff to very stiff clay and silty clay to a depth of 44 feet with an interbedded layer of silts/clayey silt and silty sand encountered at a depth of 10 feet to 14 feet. Sandy silt and silty sand was encountered at a depth of 44 to 51.5 feet, the maximum depth of exploration. The subsurface logs (Plates B-1 through B-12) depict the stratigraphic relationships of the various soil types.

The native surface clays exhibit moderate to high swell potential (Expansion Index, EI = 50 to 110) when correlated to Plasticity Index tests (ASTM D4318) performed on the native clays. The clay is expansive when wetted and can shrink with moisture loss (drying). Development of building foundations, concrete flatwork, and asphaltic concrete pavements should include provisions for mitigating potential swelling forces and reduction in soil strength, which can occur from saturation of the soil. Causes for soil saturation include landscape irrigation, broken utility lines, or capillary rise in moisture upon sealing the ground surface to evaporation.

Moisture losses can occur with lack of landscape watering, close proximity of structures to downslopes and root system moisture extraction from deep rooted shrubs and trees placed near the foundations. The design engineer (foundations) should consider the effects of non-uniform moisture conditions around the entire foundation when selecting design criteria for the foundations. Typical measures used for similar industrial projects to remediate expansive soil include:

- ▶ Replacement of expansive silts/clays with non-expansive sands or silts.
- ▶ Moisture conditioning subgrade soils to a minimum of 5% above optimum moisture (ASTM D1557) within the drying zone of surface soils.
- ▶ Capping silt/clay soil with a non-expansive sand layer of sufficient thickness (3.0 feet minimum) to reduce the effects of soil shrink/swell.
- ▶ Design of foundations that are resistant to shrink/swell forces of silt/clay soil.
- ▶ A combination of the methods described above

3.4 Groundwater

One (1) 2-inch diameter piezometer was installed in Boring B-2 to a depth of 20 feet at the project site. Groundwater was encountered in the piezometer at a depth of 5 feet on November 22, 2007, two (2) days after placement of the piezometer. There is uncertainty in the accuracy of short-term water level measurements, particularly in fine-grained soil. Groundwater levels may fluctuate with precipitation, irrigation of adjacent properties, drainage, and site grading. The referenced groundwater level should not be interpreted to represent an accurate or permanent condition.

Subsurface agricultural tile drainage pipelines (4-inch diameter plastic or clay perforated pipelines encapsulated by sand/gravel envelope) exist at a depth of 6.0 to 8.0 feet below this site and have assisted in preventing an artificially high groundwater depth. Abandoning and plugging the subsurface drainage pipelines can allow groundwater levels to rise variably across the site. Cutting the subsurface tile drain pipelines with utility trenches will likely result in some localized trench flooding. Base line collectors should be crushed in-place and trench backfill compacted (85-90%).

The 4-inch lateral pipeline drains are not required to be removed or crushed in-place. The 4-inch pipelines should be plugged if encountered during site excavations. A copy of the tile drainage system plat as obtained from Imperial Irrigation District records is attached in Appendix A (Appendix D).

3.5 Faulting

The project site is located in the seismically active Imperial Valley of southern California with numerous mapped faults of the San Andreas Fault System traversing the region. The San Andreas Fault System is comprised of the San Andreas, San Jacinto, and Elsinore Fault Zones in southern California. The Imperial fault represents a transition from the more continuous San Andreas fault to a more nearly echelon pattern characteristic of the faults under the Gulf of California (USGS, 1990). We have performed a computer-aided search of known faults or seismic zones that lie within a 34 mile (54 kilometer) radius of the project site (Table 1).

A fault map illustrating known active faults relative to the site is presented on Figure 1, *Regional Fault Map*. Figure 2 shows the project site in relation to local faults. The criterion for fault classification adopted by the California Geological Survey defines Earthquake Fault Zones along Holocene-active or pre-Holocene faults (CGS, 2018b). Earthquake Fault Zones are regulatory zones that address the hazard of surface fault rupture. A Holocene-active fault is one that has ruptured during Holocene time (within the last 11,700 years). A pre-Holocene fault is a fault that has not ruptured in the last 11,700 years. Pre-Holocene faults may still be capable of surface rupture in the future, but are not regulated by the A-P act.

Review of the current Alquist-Priolo Earthquake Fault Zone maps (CGS, 2018a) indicates that the nearest mapped Earthquake Fault Zone is the Imperial fault located approximately 1.2 miles east of the project site.

3.6 General Ground Motion Analysis

The project site is considered likely to be subjected to moderate to strong ground motion from earthquakes in the region. Ground motions are dependent primarily on the earthquake magnitude and distance to the seismogenic (rupture) zone. Acceleration magnitudes also are dependent upon attenuation by rock and soil deposits, direction of rupture and type of fault; therefore, ground motions may vary considerably in the same general area.

CBC General Ground Motion Parameters: The 2016 CBC general ground motion parameters are based on the Risk-Targeted Maximum Considered Earthquake (MCE_R). The U.S. Geological Survey “U.S. Seismic Design Maps Web Application” (USGS, 2018) was used to obtain the site coefficients and adjusted maximum considered earthquake spectral response acceleration parameters. The site soils have been classified as Site Class D (stiff soil profile). Design spectral response acceleration parameters are defined as the earthquake ground motions that are two-thirds (2/3) of the corresponding MCE_R ground motions. Design earthquake ground motion parameters are provided in Table 2. A Risk Category II was determined using Table 1604A.5 and the Seismic Design Category is E since S_1 is greater than 0.75g

The Maximum Considered Earthquake Geometric Mean (MCE_G) peak ground acceleration (PGAM) value was determined from the “U.S. Seismic Design Maps Web Application” (USGS, 2018) for liquefaction and seismic settlement analysis in accordance with 2016 CBC Section 1803A.5.12 and CGS Note 48 ($PGAM = F_{PGA} * PGA$). A PGAM value of 0.82g has been determined for the project site.

3.7 Seismic and Other Hazards

- ▶ **Groundshaking.** The primary seismic hazard at the project site is the potential for strong groundshaking during earthquakes along the Imperial, Brawley, and Superstition Hills faults.
- ▶ **Surface Rupture.** The California Geological Survey (2016) has established Earthquake Fault Zones in accordance with the 1972 Alquist-Priolo Earthquake Fault Zone Act. The Earthquake Fault Zones consists of boundary zones surrounding well defined, active faults or fault segments. The project site does not lie within an A-P Earthquake Fault Zone; therefore, surface fault rupture is considered to be low at the project site.

- ▶ **Liquefaction.** Liquefaction is a potential design consideration because of underlying saturated sandy substrata. The potential for liquefaction at the site is discussed in more detail in Section 3.8.

Other Potential Geologic Hazards.

- ▶ **Landsliding.** The hazard of landsliding is unlikely due to the regional planar topography. No ancient landslides are shown on geologic maps of the region and no indications of landslides were observed during our site investigation.
- ▶ **Volcanic hazards.** The site is not located in proximity to any known volcanically active area and the risk of volcanic hazards is considered very low.
- ▶ **Tsunamis and seiches.** The site is not located near any large bodies of water, so the threat of tsunami, seiches, or other seismically-induced flooding is unlikely.
- ▶ **Flooding.** The project site is located in FEMA Flood Zone X, an area determined to be outside the 0.2% annual chance floodplain (FIRM Panel 06025C1375C).
- ▶ **Expansive soil.** In general, much of the near surface soils in the Imperial Valley consist of silty clays and clays which are moderate to highly expansive. The expansive soil conditions are discussed in more detail in Section 3.3.

3.8 Liquefaction

Liquefaction occurs when granular soil below the water table is subjected to vibratory motions, such as produced by earthquakes. With strong ground shaking, an increase in pore water pressure develops as the soil tends to reduce in volume. If the increase in pore water pressure is sufficient to reduce the vertical effective stress (suspending the soil particles in water), the soil strength decreases and the soil behaves as a liquid (similar to quicksand). Liquefaction can produce excessive settlement, ground rupture, lateral spreading, or failure of shallow bearing foundations. Four conditions are generally required for liquefaction to occur:

- (1) the soil must be saturated (relatively shallow groundwater);
- (2) the soil must be loosely packed (low to medium relative density);
- (3) the soil must be relatively cohesionless (not clayey); and
- (4) groundshaking of sufficient intensity must occur to function as a trigger mechanism.

All of these conditions exist to some degree at this site.

Methods of Analysis: Liquefaction potential at the project site was evaluated using the 1997 NCEER Liquefaction Workshop methods. The 1997 NCEER methods utilize direct SPT blow counts or CPT cone readings from site exploration and earthquake magnitude/PGA estimates from the seismic hazard analysis. The resistance to liquefaction is plotted on a chart of cyclic shear stress ratio (CSR) versus a corrected blow count $N_{1(60)}$ or Q_{C1N} . A PGA_M value of 0.82g was used in the analysis with a 5-foot groundwater depth and a threshold factor of safety (FS) of 1.3.

The computer program CLiq (Version 2.2.0.32, Geologismiki, 2017) was utilized for liquefaction assessment at the project site. The estimated settlements have been adjusted for transition zones between layers and the post liquefaction volumetric strain has been weighed with depth (Robertson, 2014 and Cetin et al., 2009). Computer printouts of the liquefaction analyses are provided in Appendix B.

The fines content of liquefiable sands and silts increases the liquefaction resistance in that more ground motion cycles are required to fully develop increased pore pressures. The CPT tip pressures (Q_c) were adjusted to an equivalent clean sand pressure (Q_{CINCS}) in accordance with Robertson and Wride (1997).

The soil encountered at the points of exploration included saturated silts and silty sands that could liquefy during a Maximum Considered Earthquake. Liquefaction can occur within several isolated silt and sand layers between depths of 10.5 to 50 feet. The likely triggering mechanism for liquefaction appears to be strong groundshaking associated with the rupture of the Imperial and Superstition Hills faults. The analysis is summarized in the table below.

Table 3. Summary of Liquefaction Analysis

Boring Location	Depth To First Liquefiable Zone (ft)	Potential Induced Settlement (in)
CPT-1	44.5	¼
CPT-2	11.0	½
CPT-3	11.0	½
CPT-4	10.5	½

Liquefaction Induced Settlements: *Based on empirical relationships, total induced settlements are estimated to be about ½ inch should liquefaction occur.* The magnitude of potential liquefaction induced differential settlement is estimated at be two-thirds of the total potential settlement in accordance with California Special Publication 117; therefore, there is a potential for ¼ inch of liquefaction induced differential settlement at the project site.

The differential settlement based on seismic settlements is estimated at ½ inch over a distance of 100 feet. Foundations should be designed for a maximum deflection of $L/720$.

Because of the depth of the liquefiable layer, the 10.5 foot thick non-liquefiable clay layer will likely act as a bridge over the liquefiable layer resulting in a fairly uniform ground surface settlement; therefore, wide area subsidence of the soil overburden would be the expected effect of liquefaction rather than bearing capacity failure of the proposed structures.

Liquefaction Induced Ground Failure: Based on research from Ishihara (1985) and Youd and Garris (1995) small ground fissure or sand boil formation is unlikely because of the thickness of the overlying unliquefiable soil. Sand boils are conical piles of sand derived from the upward flow of groundwater caused by excess porewater pressures created during strong ground shaking. Sand boils are not inherently damaging by themselves, but are an indication that liquefaction occurred at depth (Jones, 2003). Liquefaction induced lateral spreading is not expected to occur at this site due to the planar topography. According to Youd (2005), if the liquefiable layer lies at a depth greater than about twice the height of a free face, lateral spread is not likely to develop. No slopes or free faces occur at this site except for the open drain along the east side of the site, which depths are substantially above the first liquefiable layer.

Mitigation: Based on an estimate of less than ½ inch of liquefaction induced settlements, no mitigation is required at this project site.

Section 4
DESIGN CRITERIA

4.1 Site Preparation

Clearing and Grubbing: All surface improvements, debris or vegetation including grass, crops, and weeds on the site at the time of construction should be removed from the construction area. Root balls should be completely excavated. Organic strippings should be stockpiled and not used as engineered fill. All trash, construction debris, concrete slabs, old pavement, landfill, and buried obstructions such as old foundations and utility lines exposed during rough grading should be traced to the limits of the foreign material by the grading contractor and removed under our supervision. Any excavations resulting from site clearing should be sloped to a bowl shape to the lowest depth of disturbance and backfilled under the observation of the geotechnical engineer's representative.

Mass Grading: Prior to placing any fills, the surface 12 inches of soil should be removed, the exposed surface uniformly moisture conditioned to a depth of 8 inches by discing and wetting to a minimum of optimum plus 5% and recompacted to 85% to 90% of ASTM D1557 maximum density. Onsite native clays placed as engineered fill should be uniformly moisture conditioned by discing and wetting or drying to optimum plus 5 to 10% and compacted in 6 inch maximum lifts to 85% to 90% relative compaction. Clods shall be reduced by discing to a maximum dimension of 1.0 inch prior to being placed as fill.

The site is underlain by tile drain lines at a depth of approximately 6.0 to 8.0 feet below ground surface (see Appendix A). Tile lines should be cut and plugged at the street crossings. The pipelines are likely full of water and may temporarily flood excavations if not capped promptly. Base lines (6 to 8 inch diameter) should be located and crushed in-place with the backfill compacted to a minimum 90% of ASTM D1557 maximum density.

Building Pad Preparation: The existing surface soil within the office, maintenance shop, and other light buildings foundation areas should be removed to 36 inches below the building pad elevation or existing grade (whichever is lower) extending five feet beyond all exterior wall/column lines (including adjacent concreted areas).

Exposed subgrade should be scarified to a depth of 8 inches, uniformly moisture conditioned to 5 to 10% above optimum moisture content and recompact to 85 to 90% of the maximum density determined in accordance with ASTM D1557 methods.

Heavy Loaded Structures Foundation Subgrade Preparation: For heavy loaded structures designed to be founded on structural mat foundations such as steel storage tanks, site preparation should consist of excavating to the bottom of the proposed foundation elevation (2.0 to 4.0 feet below ground surface). Exposed subgrade should be inspected by the geotechnical engineer and if found to be loose, shall be scarified to a depth of 8 inches, uniformly moisture conditioned to 4 to 8% above optimum and recompact to a minimum of 90% of the maximum density determined in accordance with ASTM D1557 methods.

Structural Fill Recommendations: The native soil is suitable for use as engineered fill provided it is free from concentrations of organic matter or other deleterious material. The fill soil should be uniformly moisture conditioned by discing and watering to the limits specified above, placed in maximum 8-inch lifts (loose), and compacted to the limits specified above. Clay soil should not be compacted greater than 90% relative compaction because highly compacted soil will result in increased swelling.

If foundation designs are to be utilized for lightly loaded structures which do not include provisions for expansive soil, an engineered building support pad consisting of 3.0 feet of granular soil, placed in maximum 8-inch lifts (loose), compacted to a minimum of 90% of ASTM D1557 maximum density at 2% below to 4% above optimum moisture, should be placed below the bottom of the slab.

Imported fill soil (for foundations designed for expansive soil conditions) should have a Plasticity Index less than 35 and sulfates (SO₄) less than 3,000 ppm. For foundations not designed for expansive soil conditions, non-expansive, granular soil meeting the USCS classifications of SM, SP-SM, or SW-SM with a maximum rock size of 3 inches and 5 to 35% passing the No. 200 sieve shall be used. The geotechnical engineer should approve imported fill soil sources before hauling material to the site. Imported granular fill should be placed in lifts no greater than 8 inches in loose thickness and compacted to a minimum of 95% of ASTM D1557 maximum dry density at optimum moisture $\pm 2\%$.

In areas other than the building pad which are to receive area concrete slabs, the ground surface should be presaturated to a minimum depth of 36 inches and then scarified to 8 inches, moisture conditioned to a minimum of 5% over optimum, and recompact to 85-90% of ASTM D1557 maximum density just prior to concrete placement.

Moisture Control and Drainage: The moisture condition of the building pad should be maintained during trenching and utility installation until concrete is placed or should be rewetted before initiating delayed construction. If soil drying is noted, a 2 to 3 inch depth of water may be used in the bottom of footings to restore footing subgrade moisture and reduce potential edge lift. Adequate site drainage is essential to future performance of the project. Infiltration of excess irrigation water and stormwaters can adversely affect the performance of the subsurface soil at the site. Positive drainage should be maintained away from all structures to prevent ponding and subsequent saturation of the native clay soil. If landscape irrigation is allowed next to the building, drip irrigation systems or lined planter boxes should be used. The subgrade soil should be maintained in a moist, but not saturated state, and not allowed to dry out. Drainage should be maintained without ponding.

Observation and Density Testing: All site preparation and fill placement should be continuously observed and tested by a representative of a qualified geotechnical engineering firm. Full-time observation services during the excavation and scarification process is necessary to detect undesirable materials or conditions and soft areas that may be encountered in the construction area. The geotechnical firm that provides observation and testing during construction shall assume the responsibility of "*geotechnical engineer of record*" and, as such, shall perform additional tests and investigation as necessary to satisfy themselves as to the site conditions and the geotechnical parameters for site development.

Auxiliary Structures Foundation Preparation: Auxiliary structures such as free standing or retaining walls should have footings extended to a minimum of 30 inches below grade. The existing soil beneath the structure foundation prepared in the manner described for the building pad except the preparation needed only to extend 18 inches below and beyond the footing.

4.2 Utility Trench Backfill

Utility Trench Backfill: Trench backfill for utilities should conform to the specifications shown on Plate D-1 (Appendix D), using either Type A, B or C backfill.

Type A backfill for HDPE pipe (above groundwater) consists of a 4 to 8 inch bed of ¾-inch crushed rock below the pipe and pipezone backfill (to 12" above top of pipe) consisting of crusher fines (sand). Sewer pipes (SDR-35), water mains, and stormdrain pipes of other than HDPE pipe may use crusher fines for bedding. The crusher fines shall be compacted to a minimum of 95% of ASTM D1557 maximum density. Pipe deflection should be checked to not exceed 2% of pipe diameter. Native clay/silt soils may be used to backfill the remainder of the trench. Soils used for trench backfill shall be compacted to a minimum of 90% of ASTM D1557 maximum density, except the top 12 inches shall be compacted to 95% (if granular trench backfill).

Type B backfill for HDPE pipe (shallow cover) requires 6 inches of ¾-inch crushed rock as bedding and to springline of the pipe. Thereafter, sand/cement slurry (3 sack cement factor) should be used to 12 inches above the top of the pipe. Native clay and silt soils may be used in the remainder of the trench backfill as specified above.

Type C backfill for HDPE pipe (below or partially below groundwater) shall consist of a geotextile filter fabric encapsulating ¾-inch crushed rock. The crushed rock thickness shall be 6 inches below and to the sides of the pipe and shall extend to 12 inches above the top of the pipe. The filter fabric shall cover the trench bottom, sidewalls and over the top of the crushed rock. Native clay and silt soils may be used in the remainder of the trench backfill as specified above.

Type C backfill must be used in wet soils and below groundwater for all buried utility pipelines. Where pipeline excavation are planned below the ground water surface, dewatering (by well points) is required to at least 24 inches below the trench bottom prior to excavation. Type A backfill may be used in the case of a dewatered trench condition in clay soils only.

On-site soil free of debris, vegetation, and other deleterious matter may be suitable for use as utility trench backfill above pipezone, but may be difficult to uniformly maintain at specified moistures and compact to the specified densities. Native backfill should only be placed and compacted after encapsulating buried pipes with suitable bedding and pipe envelope material.

Imported granular material is acceptable for backfill of utility trenches. Granular trench backfill used in building pad areas should be plugged with a solid (no clods or voids) 2-foot width of native clay soils at each end of the building foundation to prevent landscape water migration into the trench below the building.

Backfill soil of utility trenches within paved areas should be uniformly moisture conditioned to a minimum of 4% above optimum moisture, placed in layers not more than 6 inches in thickness and mechanically compacted to a minimum of 90% of the ASTM D1557 maximum dry density, except that the top 12 inches shall be compacted to 95% (if granular trench backfill).

4.3 Spread Footing Foundations and Settlements

Shallow spread and continuous wall footings are suitable to support the structures associated with the building for offices, maintenance shop, etc. provided they are structurally tied with grade-beams to continuous perimeter wall footings to resist differential movement associated with expansive soils and potential soil liquefaction at depth. Exterior footings shall be founded a minimum of 24 inches below the surface of the building support pad on a layer of properly prepared and compacted native soil or 18 inches below the surface of the building support pad when supported on a non-expansive granular fill as described in Section 4.1. Interior footings shall have a minimum embedment depth of 12 inches.

The foundations may be designed using an allowable soil bearing pressure of 1,500 psf for compacted native clay soil and 2,000 psf when foundations are supported on imported sands (extending a minimum of 1.0 feet below footings). The allowable soil pressure may be increased by 20% for each foot of embedment depth of the footings in excess of 18 inches and by one-third for short term loads induced by winds or seismic events. The maximum allowable soil pressure at increased embedment depths shall not exceed 3,000 psf (clays).

As an alternative to shallow spread foundations, flat plate structural mats or grade-beam reinforced foundations may be used to mitigate expansive soil heave and/or liquefaction related movement.

Flat Plate Structural Mats: Flat plate structural mats may be used to mitigate expansive soils at the project site. The structural mat shall have a double mat of steel (minimum No. 4's @ 12 inches O.C. each way – top and bottom) and a minimum thickness of 10 inches. Mat edges shall have a minimum edge footing of 12 inches width and 24 inches depth (below the building pad surface). Mats may be designed by CBC Chapter 18, Section 1808A.6.2 methods (*WRI/CRSI Design of Slab-on-Ground Foundations*).

Structural mats may be designed for a modulus of subgrade reaction (K_s) of 50 pci when placed on compacted clay or a subgrade modulus of 300 pci when placed on 3.0 feet of granular fill. Mats shall overlay 2 inches of sand and a 10-mil polyethylene vapor retarder. The building support pad shall be moisture conditioned and recompacted as specified in Section 4.1 of this report.

Grade-beam Reinforced Foundations: Specific soil data for structures with grade-beam reinforced foundations placed on the native clays (without replacement of the surface clays with 3.0 feet of granular fill or lime treated soil placed over native clays) are presented below in accordance with the design method given in CBC Chapter 18 Section 1808A.6.2 (*WRI/CRSI Design of Slab-on-Ground Foundations*):

Weighted Plasticity Index (PI) = 32
Slope Coefficient (C_s) = 1.0
Strength Coefficient (C_o) = 0.9
Climatic Rating (C_w) = 15
Effective PI = 26
Maximum Grade-beam Spacing = 18 feet

Resistance to horizontal loads will be developed by passive earth pressure on the sides of footings and frictional resistance developed along the bases of footings and concrete slabs. Passive resistance to lateral earth pressure may be calculated using an equivalent fluid pressure of 250 pcf (300 pcf for imported sands) to resist lateral loadings.

The top one foot of embedment should not be considered in computing passive resistance unless the adjacent area is confined by a slab or pavement. An allowable friction coefficient of 0.25 (0.35 for imported sands) may also be used at the base of the footings to resist lateral loading.

Foundation movement under the estimated static (non-seismic) loadings and static site conditions are estimated to not exceed 1 inch with differential movement of about two-thirds of total movement for the loading assumptions stated above when the subgrade preparation guidelines given above are followed. Seismically induced liquefaction settlement of the surrounding land mass and structure may be on the order of ½ inch (total) and ¼ inch (differential).

Structural Mat Foundations for Heavy Structures: Structural concrete mat foundations are suitable to support the proposed above ground steel storage tanks. The mat shall be founded on the native clays or a layer of properly prepared and compacted soil as described in the Site Preparation Section. The foundations may be designed using an allowable soil bearing pressure of 1,500 psf at 2.0 foot depth into native clay soils. The allowable soil pressure may be increased by 20% for each foot of embedment depth in excess of 24 inches and by one-third for short term loads induced by winds or seismic events. The maximum allowable soil pressure at increased embedment depths shall not exceed 4,000 psf.

Structural mats may be designed for a modulus of subgrade reaction (K_s) of 100 pci when placed on compacted native clay. The structure support pad shall consist of stiff native clay or shall be moisture conditioned and recompacted as specified in the Site Preparation Section of this Report.

Resistance to horizontal loads will be developed by passive earth pressure on the sides of footings and frictional resistance developed along the bases of footings and concrete slabs. Passive resistance to lateral earth pressure may be calculated using an equivalent fluid pressure of 250 pcf to resist lateral loadings. The top one foot of embedment should not be considered in computing passive resistance unless the adjacent area is confined by a slab or pavement. An allowable friction coefficient of 0.30 may also be used at the base of the structural mat to resist lateral loading.

Settlement estimates (in inches) developed for different footing and mat dimensions embedded a minimum of 2.0 feet into native soils and loaded to 1000, 2,000, 3,000 and 4,000 psf follow:

Table 4: Settlement Estimates (inches)

Load, psf	Size of Footing or Mat (ft.)					
	5 x 5	10 x 10	15 x 15	20 x 20	25 x 25	30 x 30
1,000	0.6	1.0	1.3	1.6	1.8	2.0
2,000	1.0	1.7	2.2	2.7	3.1	3.4
3,000	1.3	2.3	3.0	3.6	4.1	4.6
4,000	1.6	2.8	3.6	4.4	5.1	5.7

4.4 Steel Tank Foundations and Settlements

Site Preparation and Grading: The existing soils underlying the steel storage tanks should be removed to a depth of 36 inches below ground surface extending to a minimum of 5 feet beyond the perimeter of the tanks. The surface 8 inches of native soil exposed at the subexcavation and footing excavation level should be compacted to 85 - 90 % of ASTM D1557 maximum density at 5 to 10% above optimum moisture. The area should then be brought to finish grade with engineered fill consisting of the following components:

- 24 inches of crushed aggregate base
- 8 inches of crushed rock
- 4 inches of oiled sand

As a minimum, a steel ring should be placed to contain the crushed rock subgrade below the tank. The rock fill should be placed to the top of the ring wall. The fill may be crowned about 40% of the total center settlement to allow for differential settlement between the tank perimeter and center.

The engineered fill should be placed in 8-inch maximum loose lifts and compacted to a minimum 95% of ASTM D1557 maximum density within 2% of optimum moisture. The crushed rock tank underlayment should meet the gradation requirements of ASTM C33, size 57 (1" x No. 4 rock). The proposed source of engineered fill and rock should be submitted to the geotechnical engineer for review and testing to verify conformance to these requirements.

Tank Foundations: Flexible steel tanks, which can withstand large settlements, generally require minimal foundations, allowing settlement to occur and using flexible connections to inlet/outlet piping. The tanks should have a perimeter ring wall foundation which supports the tank wall and roof.

The interior footings and the ringwall may be proportioned for a net load of 1,500 to 2,000 psf for roof dead load (plus sustained live load) excluding the weight of the liquid fertilizer. This soil pressure can be increased by one third for transient and seismic loads. The minimum depth of the ring wall footing should be 18 inches below the finished ground surface. The minimum footing width should be 12 inches.

Estimated Tank Settlements: The subsurface clays are saturated and overconsolidated in their natural state. Imposed foundations loads can consolidate the soils by reducing the void ratio through pore water expulsion. The amount of vertical settlement that occurs as a result of soil compression varies with applied loads, foundation shape and width.

Moderately loaded structures, such as the flexible steel tanks which can withstand large settlements, will generally require minimal foundations, allowing settlement to occur and using flexible connections to inlet/outlet utility lines. The silts and clays will consolidate fairly slowly because of their low permeability. Flexible connections such as "Flex-Tend" expansion joints should be used to connect exterior piping with the tank. The tank should be preloaded and monitored for settlement prior to making piping connections. It may be necessary to readjust piping connections after the loading sequence.

Estimated settlements were calculated using the consolidation and field data test data for the silt and clay strata and Schmertman's analysis for the granular strata using the CPT engineering properties correlations. The soils to a depth of the diameter of the tanks (20 to 100 feet) may be significantly stressed so as to contribute to the overall settlement.

The estimated settlements for different tanks heights and diameters are provided in the table below:

Table 5: Estimated Center Settlements of Tanks

Height, ft	Diameter (ft)				
	20	40	60	80	100
20	2.5"	4.0"	4.7"	5.1"	5.4"
24	2.8"	4.4"	5.2"	5.7"	5.9"
28	3.1"	4.9"	5.9"	6.4"	6.7"
36	3.6"	5.8"	6.9"	7.4"	7.8"
50	4.5"	7.1"	8.4"	9.1"	9.5"
60	5.0"	8.0"	9.4"	10.2"	10.6"
70	5.5"	8.7"	10.2"	11.0"	11.6"

The estimated settlements for the tanks are approximately 2.5 to 11.6 inches in the center of the tanks and about 1.0 to 4.9 inches at the edge of the tanks (depending on tank dimensions). Since the settlement is deep seated, little is gained by further excavation and replacement of compacted granular fill to reduce settlements. Ground improvement methods (geopiers, soil-cement mixing, etc.) are may be considered to reduce settlements.

4.5 Slabs-On-Grade

Structural Concrete: Structural concrete slabs are those slabs (foundations) that underlie structures or patio covers (shades). These slabs that are placed over native clay soil should be designed in accordance with Chapter 18 of the 2016 CBC and shall be a minimum of 5 inches thick due to expansive soil conditions. Concrete floor slabs shall be monolithically placed with the footings (no cold joints) unless placed on 3.0 feet of granular fill or lime treated soil.

American Concrete Institute (ACI) guidelines (ACI 302.1R-04 Chapter 3, Section 3.2.3) provide recommendations regarding the use of moisture barriers beneath concrete slabs.

The concrete floor slabs should be underlain by a 10-mil polyethylene vapor retarder that works as a capillary break to reduce moisture migration into the slab section. All laps and seams should be overlapped 6-inches or as recommended by the manufacturer. The vapor retarder should be protected from puncture. The joints and penetrations should be sealed with the manufacturer's recommended adhesive, pressure-sensitive tape, or both. The vapor retarder should extend a minimum of 12 inches into the footing excavations. The vapor retarder should be covered by 4 inches of clean sand (Sand Equivalent SE>30) unless placed on 3.0 feet of granular fill, in which case, the vapor retarder may lie directly on the granular fill with 2 inches of clean sand cover.

Placing sand over the vapor retarder may increase moisture transmission through the slab, because it provides a reservoir for bleed water from the concrete to collect. The sand placed over the vapor retarder may also move and mound prior to concrete placement, resulting in an irregular slab thickness. For areas with moisture sensitive flooring materials, ACI recommends that concrete slabs be placed without a sand cover directly over the vapor retarder, provided that the concrete mix uses a low-water cement ratio and concrete curing methods are employed to compensate for release of bleed water through the top of the slab. The vapor retarder should have a minimum thickness of 15-mil (Stego-Wrap or equivalent).

Structural concrete slab reinforcement should consist of chaired rebar slab reinforcement (minimum of No. 3 bars at 16-inch centers, both horizontal directions) placed at slab mid-height to resist potential swell forces and cracking. Slab thickness and steel reinforcement are minimums only and should be verified by the structural engineer/designer knowing the actual project loadings.

All steel components of the foundation system should be protected from corrosion by maintaining a 3-inch minimum concrete cover of densely consolidated concrete at footings (by use of a vibrator). The construction joint between the foundation and any mowstrips/sidewalks placed adjacent to foundations should be sealed with a polyurethane based non-hardening sealant to prevent moisture migration between the joint. Epoxy coated embedded steel components (ASTM D3963/A934) or permanent waterproofing membranes placed at the exterior footing sidewall may also be used to mitigate the corrosion potential of concrete placed in contact with native soil.

Control joints should be provided in all concrete slabs-on-grade at a maximum spacing (in feet) of 2 to 3 times the slab thickness (in inches) as recommended by American Concrete Institute (ACI) guidelines. All joints should form approximately square patterns to reduce randomly oriented contraction cracks. Contraction joints in the slabs should be tooled at the time of the pour or sawcut ($\frac{1}{4}$ of slab depth) within 6 to 8 hours of concrete placement. Construction (cold) joints in foundations and area flatwork should either be thickened butt-joints with dowels or a thickened keyed-joint designed to resist vertical deflection at the joint. All joints in flatwork should be sealed to prevent moisture, vermin, or foreign material intrusion. Precautions should be taken to prevent curling of slabs in this arid desert region (refer to ACI guidelines).

Non-structural Concrete: All non-structural independent flatwork (sidewalks and housekeeping slabs) shall be a minimum of 4 inches thick and should be placed on a minimum of 2 inches of concrete sand or aggregate base, dowelled to the perimeter foundations where adjacent to the building to prevent separation and sloped 2% (sidewalks) or 1 to 2% (housekeeping slabs) away from the building. Housekeeping slabs with shade structures shall have a perimeter footing (18-inch embedment depth) and shall have interior grade beams (12-inch minimum embedment depth) at 15 feet on center. Planters that trap water between sidewalks and foundations are not allowed.

A minimum of 24 inches of moisture conditioned (5% minimum above optimum) and 8 inches of compacted subgrade (85 to 90%) should underlie all independent flatwork. Flatwork which contains steel reinforcing (except wire mesh) should be underlain by a 10-mil (minimum) polyethylene separation sheet and at least a 2-inch sand cover. All flatwork should be jointed in square patterns and at irregularities in shape at a maximum spacing of 8 feet or the least width of the sidewalk.

4.6 Concrete Mixes and Corrosivity

Selected chemical analyses for corrosivity were conducted in 2007 on bulk samples of the near surface soil from the project site. The native soils were found to have S1 to S2 (moderate to severe) levels of sulfate ion concentration (848 to 3,831 ppm). Sulfate ions in high concentrations can attack the cementitious material in concrete, causing weakening of the cement matrix and eventual deterioration by raveling.

The following table provides American Concrete Institute (ACI) recommended cement types, water-cement ratio and minimum compressive strengths for concrete in contact with soils:

Table 6. Concrete Mix Design Criteria due to Soluble Sulfate Exposure

Sulfate Exposure Class	Water-soluble Sulfate (SO ₄) in soil, ppm	Cement Type	Maximum Water-Cement Ratio by weight	Minimum Strength f _c (psi)
S0	0-1,000	–	–	–
S1	1,000-2,000	II	0.50	4,000
S2	2,000-20,000	V	0.45	4,500
S3	Over 20,000	V (plus Pozzolon)	0.45	4,500

Note: From ACI 318-14 Table 19.3.1.1 and Table 19.3.2.1

A minimum of 6.0 sacks per cubic yard of concrete (4,500 psi) of Type V Portland Cement with a maximum water/cement ratio of 0.45 (by weight) should be used for concrete placed in contact with native soil on this project (sitework including streets, sidewalks, driveways, patios, and foundations). Admixtures may be required to allow placement of this low water/cement ratio concrete. Thorough concrete consolidation and hard trowel finishes should be used due to the aggressive soil exposure.

The native soil has severe to very severe levels of chloride ion concentration (720 to 4,480 ppm). Chloride ions can cause corrosion of reinforcing steel, anchor bolts and other buried metallic conduits. Resistivity determinations on the soil indicate very severe potential for metal loss because of electrochemical corrosion processes.

Mitigation of the corrosion of steel can be achieved by using steel pipes coated with epoxy corrosion inhibitors, asphaltic and epoxy coatings, cathodic protection or by encapsulating the portion of the pipe lying above groundwater with a minimum of 3 inches of densely consolidated concrete. *No metallic water pipes or conduits should be placed below foundations.*

Foundation designs shall provide a minimum concrete cover of three (3) inches around steel reinforcing or embedded components (anchor bolts, etc.) exposed to native soil or landscape water (to 18 inches above grade).

If the 3-inch concrete edge distance cannot be achieved, all embedded steel components (anchor bolts, etc.) shall be epoxy coated for corrosion protection (in accordance with ASTM D3963/A934) or a corrosion inhibitor and a permanent waterproofing membrane shall be placed along the exterior face of the exterior footings. *Hold-down straps should not be used at foundation edges due to corrosion of metal at its protrusion from the slab edge.* Additionally, the concrete should be thoroughly vibrated at footings during placement to decrease the permeability of the concrete. Exterior foundation faces exposed to native soils (without adjacent mowstrips, sidewalks, or patios) should be coated with a permanent waterproofing membrane to prevent salt migration into concrete.

Copper water piping (except for trap primers) should not be placed under floor slabs. All copper piping within 18 inches of ground surface shall be wrapped with two layers of 10 mil plumbers tape or sleeved with PVC piping to prevent contact with soil. The trap primer pipe shall be completely encapsulated in a PVC sleeve and Type K copper should be utilized if polyethylene tubing cannot be used. Pressurized waterlines are not allowed under the floor slab. Fire protection piping (risers) should be placed outside of the building foundation.

4.7 Excavations

All site excavations should conform to CalOSHA requirements for Type B soil. The contractor is solely responsible for the safety of workers entering trenches. Temporary excavations with depths of 4 feet or less may be cut nearly vertical for short duration. Excavations deeper than 4 feet will require shoring or slope inclinations in conformance to CAL/OSHA regulations for Type B soil.

Surcharge loads of stockpiled soil or construction materials should be set back from the top of the slope a minimum distance equal to the height of the slope. All permanent slopes should not be steeper than 3:1 to reduce wind and rain erosion. Protected slopes with ground cover may be as steep as 2:1. However, maintenance with motorized equipment may not be possible at this inclination.

Groundwater was encountered at a depth of 5 feet on November 22, 2007. The contractor is cautioned to evaluate soil moisture and groundwater conditions at the time of bidding. Running ground conditions should be anticipated below 10 feet.

Subsurface agricultural tile drainage pipelines (4-inch diameter plastic or clay perforated pipelines encapsulated by sand/gravel envelope) exist at a depth of 6.0 to 8.0 feet below this site and have assisted in preventing an artificially high groundwater depth. Abandoning and plugging the subsurface drainage pipelines can allow groundwater levels to rise variably across the site. Cutting the subsurface tile drain pipelines with utility trenches will likely result in some localized trench flooding. Base line collectors should be crushed in-place and trench backfill compacted (85-90%).

The 4-inch lateral pipeline drains are not required to be removed or crushed in-place. The 4-inch pipelines should be plugged if encountered during site excavations. A copy of the tile drainage system plat as obtained from Imperial Irrigation District records is attached in Appendix A.

4.8 Lateral Earth Pressures

Earth retaining structures, such as retaining walls, should be designed to resist the soil pressure imposed by the retained soil mass. Walls with granular drained backfill may be designed for an assumed static earth pressure equivalent to that exerted by a fluid weighing 60 (45 silt) (45 sand) pcf for unrestrained (active) conditions (able to rotate 0.1% of wall height), and 100 (100 silt) (60 sand) pcf for restrained (at-rest) conditions. These values should be verified at the actual wall locations during construction.

When applicable (unbalanced retaining wall greater than 6 feet high) seismic earth pressure on walls may be assumed to exert a uniform pressure distribution of $7.5H$ psf against the back of the wall. The total seismic load is assumed to act as a point load at $0.6H$ above the base of the wall. The term H is the height of the backfill against a retaining wall in feet. The recommended value $7.5H$ was derived from the following formula:

$$P_e = \frac{3}{8} (k_h) \gamma H^2$$

where: $k_h = 0.75 a_{max}$ (a_{max} is a pseudo-static maximum of 0.20g)
 $\gamma = 125$ pcf

which equates to $P_e = 7.0H^2$ (acting as a point load at $0.6H$ from base of wall)

A pseudo-static a_{max} is typically used in slope stability analysis.

Surcharge loads should be considered if loads are applied within a zone between the face of the wall and a plane projected behind the wall 45 degrees upward from the base of the wall. The increase in lateral earth pressure acting uniformly against the back of the wall should be taken as 50% of the surcharge load within this zone. Areas of the retaining wall subjected to traffic loads should be designed for a uniform surcharge load equivalent to two feet of native soil.

Walls should be provided with backdrains to reduce the potential for the buildup of hydrostatic pressure. The drainage system should consist of a composite HDPE drainage panel or a 2-foot wide zone of free draining crushed rock placed adjacent to the wall and extending $\frac{2}{3}$ the height of the wall. The gravel should be completely enclosed in an approved filter fabric to separate the gravel and backfill soil. A perforated pipe should be placed perforations down at the base of the permeable material at least six inches below finished floor elevations. The pipe should be sloped to drain to an appropriate outlet that is protected against erosion. Walls should be properly waterproofed. The project geotechnical engineer should approve any alternative drain system.

4.9 Seismic Design

This site is located in the seismically active southern California area and the site structures are subject to strong ground shaking due to potential fault movements along the Brawley, Superstition Hills, and Imperial Faults. Engineered design and earthquake-resistant construction are the common solutions to increase safety and development of seismic areas. Designs should comply with the latest edition of the CBC for Site Class D using the seismic coefficients given in Section 3.6 and Table 2 of this report.

4.10 Soil Erosion Factors for SWPPP Plans

The site soils are classified as heavy clays with greater than 40% clay fraction soil particles (5% sand, 55% silt, and 40% clay). Groundwater can be expected at a depth of 5 feet below ground surface.

4.11 Railroad Spur Line Subgrade Preparation

Option No. 1:

The site preparation for the railroad spur line may consist of the removal of 1.5 feet of native soil (17.33 feet wide) along the spur route. The exposed subgrade soil should be scarified and compacted to a minimum of 90% of ASTM D1557 maximum density at a minimum of 4% above optimum moisture and a geotextile fabric placed over the subgrade as specified below.

Option No. 2:

If it is desired that an “above grade” ballast and sub-ballast be used, the surface 1.5 feet of native soil shall be removed to a width of 23.33 feet and recompacted to at least 90% (ASTM D1557) at a minimum of 4% above optimum moisture. A geotextile stabilization/separation fabric such as Mirafi “Geolon HP 370” or equivalent should be placed over the prepared native clay subgrade prior to placing sub-ballast.

An 18-inch layer of Caltrans Class 2 Aggregate Base (1½ inch grading) material shall be placed as sub-ballast and compacted in 6-inch lifts over the geotextile fabric. If placed above grade, the sub-ballast should be 23.33 feet wide and extend upward with 2:1 outer slopes to a top width of 17.33 feet wide. If no geotextile is used, an additional 6 inches of class 2 aggregate base should be used.

The Class 2 base shall be moisture conditioned ($\pm 2\%$ of optimum moisture) and compacted to a minimum of 95% of ASTM D1557 maximum density. After sub-ballast placement, a minimum of 8 inches of railroad ballast shall be placed below the railroad ties. The ballast shall be sloped no steeper than 3:1 giving a 13.33-foot wide surface to support the rail ties.

4.12 Pavements

Pavements should be designed according to the 2012 Caltrans Highway Design Manual or other acceptable methods. Traffic indices were not provided by the project engineer or owner; therefore, we have provided structural sections for several traffic indices for comparative evaluation. The public agency or design engineer should decide the appropriate traffic index for the site.

Maintenance of proper drainage is necessary to prolong the service life of the pavements.

Based on the current Caltrans method, an R-value of 5 for the subgrade soil and assumed traffic indices, the following table provides our estimates for asphaltic concrete (AC) and Portland Cement Concrete (PCC) pavement sections.

Table 7. Pavement Structural Sections

R-Value of Subgrade Soil - 5		Design Method - Caltrans 2012		
Traffic Index	Flexible Pavements		Rigid (PCC) Pavements	
	Asphaltic Concrete Thickness (in.)	Aggregate Base Thickness (in.)	Concrete Thickness (in.)	Aggregate Base Thickness (in.)
4.0	3.0	6.5	5.0	6.0
5.0	3.0	10.0	5.5	6.0
6.0	4.0	11.5	6.0	8.0
6.5	4.0	14.0	7.0	8.0
8.0	5.0	17.5	8.0	11.0
10.0	5.0	23.5	9.0	13.0

Notes:

- 1) Asphaltic concrete shall be Caltrans, Type B, ¾ inch maximum (½ inch maximum for parking areas), medium grading with PG70-10 asphalt concrete, compacted to a minimum of 95% of the Hveem density (CAL 308) or a minimum of 92% of the Maximum Theoretical Density (ASTM D2041).
- 2) Aggregate base shall conform to Caltrans Class 2 (¾ in. maximum), compacted to a minimum of 95% of ASTM D1557 maximum dry density.
- 3) Place pavements on 12 inches of moisture conditioned (minimum 4% above optimum if clays) native clay soil compacted to a minimum of 90% (95% if sand subgrade) of the maximum dry density determined by ASTM D1557. Prewetting of subgrade soils (to 3.5 feet) may be required depending on moisture of subgrade at time of aggregate base placement.
- 4) Portland cement concrete for pavements should have Type V cement, a minimum compressive strength of 4,500 psi at 28 days, and a maximum water-cement ratio of 0.45.
- 5) Typical Street Classifications (Imperial County).

Parking Areas:	TI = 4.0
Cul-de-Sacs:	TI = 5.0
Local Streets:	TI = 6.0
Minor Collectors:	TI = 6.5
Major Collectors:	TI = 8.0
Minor Arterial:	TI = 10.0

Section 5
LIMITATIONS AND ADDITIONAL SERVICES

5.1 Limitations

The findings and professional opinions within this report are based on current information regarding the proposed JR Simplot Fertilizer Terminal located north of Harris Road along the west side of the Union Pacific Railroad tracks south of Brawley, California. The conclusions and professional opinions of this report are invalid if:

- ▶ Structural loads change from those stated or the structures are relocated.
- ▶ The Additional Services section of this report is not followed.
- ▶ This report is used for adjacent or other property.
- ▶ Changes of grade or groundwater occur between the issuance of this report and construction other than those anticipated in this report.
- ▶ Any other change that materially alters the project from that proposed at the time this report was prepared.

Findings and professional opinions in this report are based on selected points of field exploration, geologic literature, laboratory testing, and our understanding of the proposed project. Our analysis of data and professional opinions presented herein are based on the assumption that soil conditions do not vary significantly from those found at specific exploratory locations. Variations in soil conditions can exist between and beyond the exploration points or groundwater elevations may change. If detected, these conditions may require additional studies, consultation, and possible design revisions.

This report contains information that may be useful in the preparation of contract specifications. However, the report is not worded in such a manner that we recommend its use as a construction specification document without proper modification. The use of information contained in this report for bidding purposes should be done at the contractor's option and risk.

This report was prepared according to the generally accepted *geotechnical engineering standards of practice* that existed in Imperial County at the time the report was prepared. No express or implied warranties are made in connection with our services.

This report should be considered invalid for periods after two years from the report date without a review of the validity of the findings and professional opinions by our firm, because of potential changes in the Geotechnical Engineering Standards of Practice.

The client has responsibility to see that all parties to the project including, designer, contractor, and subcontractor are made aware of this entire report. The use of information contained in this report for bidding purposes should be done at the contractor's option and risk.

5.2 Additional Services

We recommend that a qualified geotechnical consultant be retained to provide the tests and observations services during construction. *The geotechnical engineering firm providing such tests and observations shall become the geotechnical engineer of record and assume responsibility for the project.*

The professional opinions presented in this report are based on the assumption that:

- ▶ Consultation during development of design and construction documents to check that the geotechnical professional opinions are appropriate for the proposed project and that the geotechnical professional opinions are properly interpreted and incorporated into the documents.
- ▶ Landmark Consultants will have the opportunity to review and comment on the plans and specifications for the project prior to the issuance of such for bidding.
- ▶ Observation, inspection, and testing by the geotechnical consultant of record during site clearing, grading, excavation, placement of fills, building pad and subgrade preparation, and backfilling of utility trenches.
- ▶ Observation of foundation excavations and reinforcing steel before concrete placement.
- ▶ Other consultation as necessary during design and construction.

We emphasize our review of the project plans and specifications to check for compatibility with our professional opinions and conclusions. Additional information concerning the scope and cost of these services can be obtained from our office.

TABLES

Table 1
Summary of Characteristics of Closest Known Active Faults

Fault Name	Approximate Distance (miles)	Approximate Distance (km)	Maximum Moment Magnitude (Mw)	Fault Length (km)	Slip Rate (mm/yr)
Imperial	1.2	2.0	7	62 ± 6	20 ± 5
Superstition Hills	4.8	7.6	6.6	23 ± 2	4 ± 2
Brawley *	4.8	7.7			
Superstition Mountain	7.2	11.4	6.6	24 ± 2	5 ± 3
Rico *	10.7	17.1			
Unnamed 1*	14.9	23.8			
Unnamed 2*	15.6	24.9			
Yuha*	16.9	27.0			
Yuha Well *	18.0	28.8			
Shell Beds	18.0	28.8			
Elmore Ranch	19.1	30.6	6.6	29 ± 3	1 ± 0.5
Painted Gorge Wash*	19.9	31.9			
Vista de Anza*	21.1	33.7			
Laguna Salada	21.4	34.3	7	67 ± 7	3.5 ± 1.5
Borrego (Mexico)*	23.4	37.4			
Ocotillo*	25.0	39.9			
San Jacinto - Borrego	26.3	42.1	6.6	29 ± 3	4 ± 2
Cerro Prieto *	27.0	43.2			
Elsinore - Coyote Mountain	27.9	44.7	6.8	39 ± 4	4 ± 2
Pescadores (Mexico)*	29.0	46.4			
Cucapah (Mexico)*	30.3	48.5			
San Andreas - Coachella	33.5	53.5	7.2	96 ± 10	25 ± 5

* Note: Faults not included in CGS database.

Table 2
2016 California Building Code (CBC) and ASCE 7-10 Seismic Parameters

Soil Site Class:	D	<u>CBC Reference</u>
Latitude:	32.8856 N	Table 20.3-1
Longitude:	-115.5636 W	
Risk Category:	II	
Seismic Design Category:	E	

Maximum Considered Earthquake (MCE) Ground Motion

Mapped MCE _R Short Period Spectral Response	S_s	2.139 g	Figure 1613.3.1(1)
Mapped MCE _R 1 second Spectral Response	S₁	0.831 g	Figure 1613.3.1(2)
Short Period (0.2 s) Site Coefficient	F_a	1.00	Table 1613.3.3(1)
Long Period (1.0 s) Site Coefficient	F_v	1.50	Table 1613.3.3(2)
MCE _R Spectral Response Acceleration Parameter (0.2 s)	S_{MS}	2.139 g	= F _a * S _s Equation 16-37
MCE _R Spectral Response Acceleration Parameter (1.0 s)	S_{M1}	1.247 g	= F _v * S ₁ Equation 16-38

Design Earthquake Ground Motion

Design Spectral Response Acceleration Parameter (0.2 s)	S_{DS}	1.426 g	= 2/3 * S _{MS}	Equation 16-39
Design Spectral Response Acceleration Parameter (1.0 s)	S_{D1}	0.831 g	= 2/3 * S _{M1}	Equation 16-40
Risk Coefficient at Short Periods (less than 0.2 s)	C_{RS}	1.065		ASCE Figure 22-17
Risk Coefficient at Long Periods (greater than 1.0 s)	C_{RL}	1.024		ASCE Figure 22-18
	T_L	8.00 sec		ASCE Figure 22-12
	T_O	0.12 sec	= 0.2 * S _{D1} / S _{DS}	
	T_S	0.58 sec	= S _{D1} / S _{DS}	
Peak Ground Acceleration	PGA_M	0.82 g		ASCE Equation 11.8-1

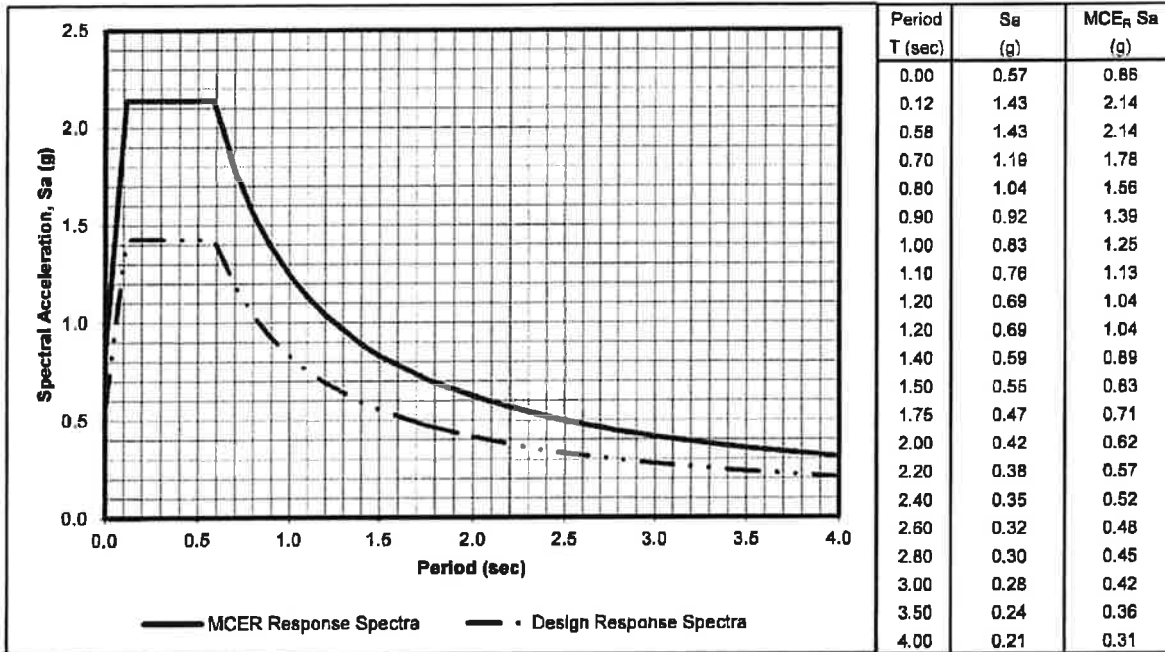

FIGURES

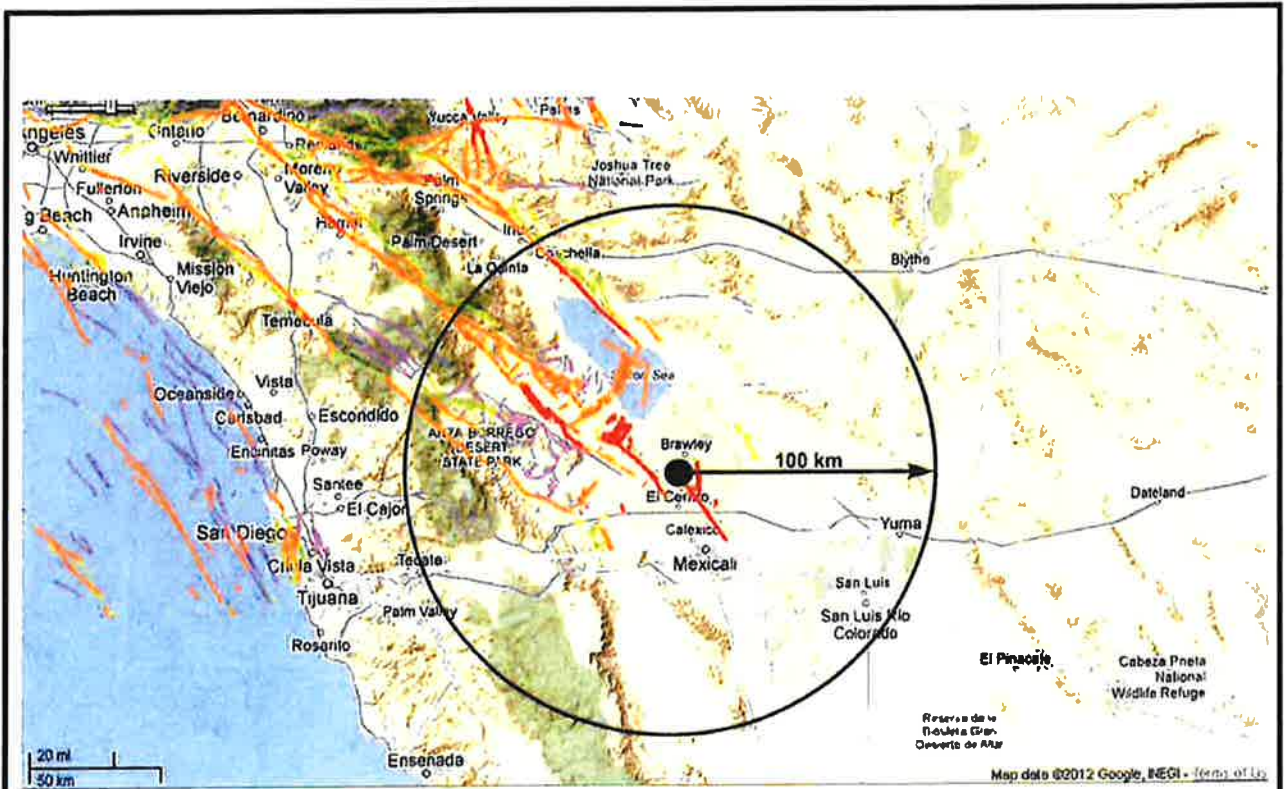

Source: California Geological Survey 2010 Fault Activity Map of California
<http://www.quake.ca.gov/gmaps/FAM/faultactivitymap.htm#>

<p>LANDMARK Geo-Engineers and Geologists Project No.: LE18215</p>	<p>Regional Fault Map</p>	<p>Figure 1</p>
--	----------------------------------	------------------------

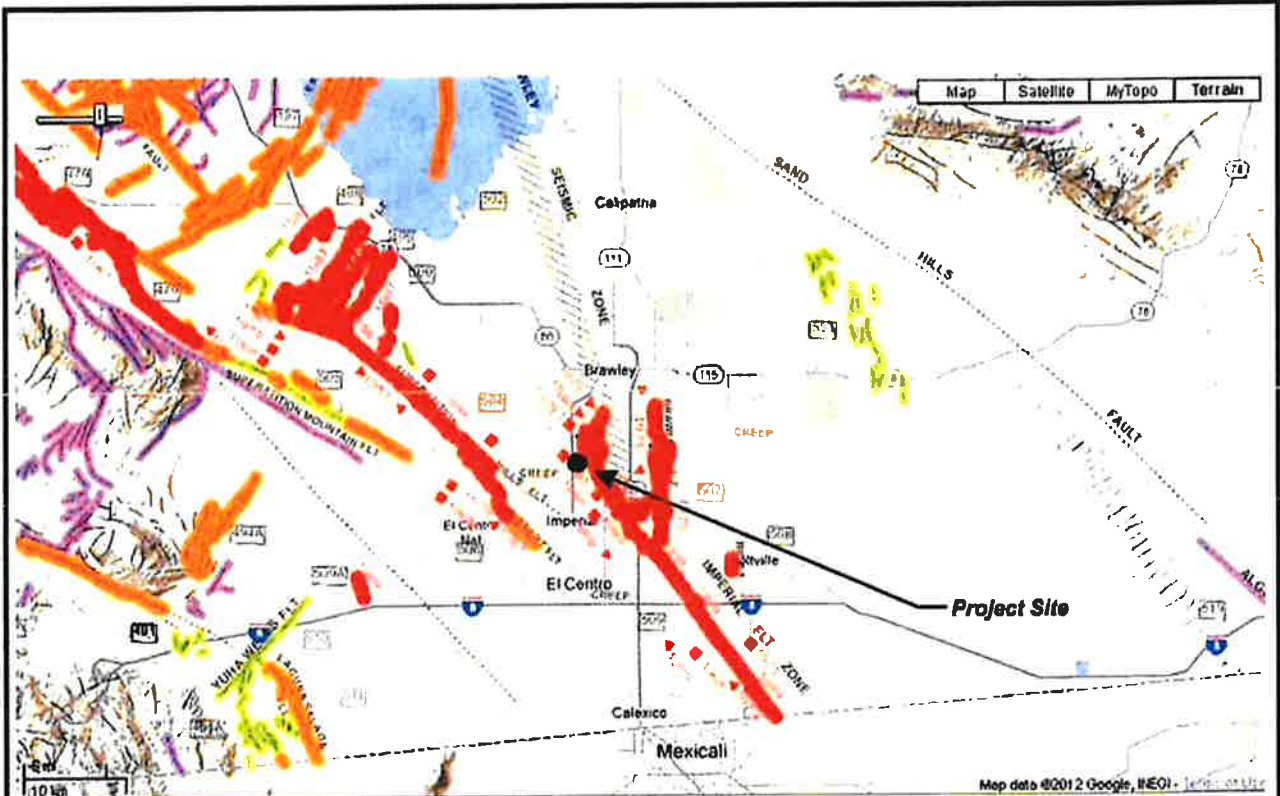

Source: California Geological Survey 2010 Fault Activity Map of California
<http://www.quake.ca.gov/gmaps/FAM/faultactivitymap.htm>

LANDMARK
 Geo-Engineers and Geologists
 Project No.: LE18215











Map of Local Faults

Figure 2



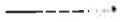

EXPLANATION

Fault traces on land are indicated by solid lines where well located, by dashed lines where approximately located or inferred, and by dotted lines where concealed by younger rocks or by lakes or bays. Fault traces are queried where continuation or extension is uncertain. Concealed faults in the Great Valley are based on maps of selected subsurface horizons, so locations shown are approximate and may indicate structural trend only. All offshore faults based on seismic reflection profile records are shown as solid lines where well defined, dashed where inferred, queried where uncertain.



FAULT CLASSIFICATION COLOR CODE (Indicating Recency of Movement)















-  Fault along which historic (last 200 years) displacement has occurred and is associated with one or more of the following:
 - (a) a recorded earthquake with surface rupture. (Also included are some well-defined surface breaks caused by ground shaking during earthquakes, e.g. extensive ground breakage, not on the White Wolf fault, caused by the Arvin-Tehachapi earthquake of 1952). The date of the associated earthquake is indicated. Where repeated surface ruptures on the same fault have occurred, only the date of the latest movement may be indicated, especially if earlier reports are not well documented as to location of ground breaks.
 - (b) fault creep/slippage - slow ground displacement usually without accompanying earthquakes
 - (c) deformed survey lines
-  A triangle to the right or left of the date indicates termination point of observed surface displacement. Solid red triangle indicates known location of rupture termination point. Open black triangle indicates uncertain or estimated location of rupture termination point.
-  Date bracketed by triangles indicates local fault break.
-  No triangle by date indicates an intermediate point along fault break.
-  Fault that exhibits fault creep/slippage. Measured line indicates linear extent of fault creep. Annotation (creep with loader) indicates representative locations where fault creep has been observed and recorded.
-  Seismicity on fault indicates where fault creep/slippage has occurred that has been triggered by an earthquake on some other fault. Date of causative earthquake indicated. Squares to right and left of date indicate terminal points between which triggered creep/slippage has occurred (creep either continuous or intermittent between these end points).
-  Holocene fault displacement (during past 11,700 years) without historic record. Geomorphic evidence for Holocene faulting includes sand ponds, scars showing little erosion, or the following features in Holocene age deposits: offset stream courses, linear scarps, shutter ridges, and triangular faceted spurs. Recency of faulting offshore is based on the interpreted age of the youngest strata displaced by faulting.
-  Late Quaternary fault displacement (during past 700,000 years). Geomorphic evidence similar to that described for Holocene faults except features are less distinct. Faulting may be younger, but lack of younger overlying deposits precludes more accurate age classification.
-  Quaternary fault (age undifferentiated). Most faults of this category show evidence of displacement sometime during the past 1.6 million years; possible exceptions are faults which displace rocks of undifferentiated Pleistocene age. Unnumbered Quaternary faults were based on Fault Map of California, 1975 See Bulletin 201, Appendix D for source data.
-  Pre-Quaternary fault (older than 1.6 million years) or fault without recognized Quaternary displacement. Some faults are shown in this category because the source of mapping used was of reconnaissance nature, or were not done with the object of dating fault displacements. Faults in this category are not necessarily inactive.

ADDITIONAL FAULT SYMBOLS

-  Bar and ball on downthrown side (relative or apparent)
-  Arrows along fault indicate relative or apparent direction of lateral movement.
-  Arrow on fault indicates direction of dip.
-  Low angle fault (barbs on upper plate). Fault surface generally dips less than 45° but locally may have been subsequently steepened. On offshore faults, barbs simply indicate a reverse fault regardless of sense of dip.

OTHER SYMBOLS

-  Numbers refer to annotations listed in the appendices of the accompanying report. Annotations include fault name, age of fault displacement, and pertinent references including Earthquake Fault Zone maps where a fault has been zoned by the Alquist-Priolo Earthquake Fault Zoning Act. This Act requires the State Geological to delineate zones to encompass faults with Holocene displacement.
-  Structural discontinuity (offshore) separating differing Neogene structural domains. May indicate discont. nukes between basement rocks.
-  Brayley Seismic Zone, a linear zone of seismicity locally up to 10 km wide associated with the releasing step between the Imperial and San Andreas faults.

Geologic Time Scale	Years Before Present (Approx.)	Fault Symbol	Recency of Movement	DESCRIPTION	
				ON LAND	OFFSHORE
Quaternary	Historic / Recent			Quaternary faults along major faults for immediate and recent displacement (see Appendix A for details)	
	200				
	11,700				
Early Quaternary	Pleistocene				
	700,000				
Pre-Quaternary	1,000,000				
	4.6 Billion (Age of Earth)			Faults without recognized Quaternary displacement or showing evidence of no displacement during Quaternary time. Not necessarily inactive.	Fault date times of Pliocene or older age.

* Quaternary now recognized as extending to 2.8 Ma (Webber and Galloway, 2008). Quaternary faults in this map were established using the previous 1.6 Ma criterion.

APPENDIX A

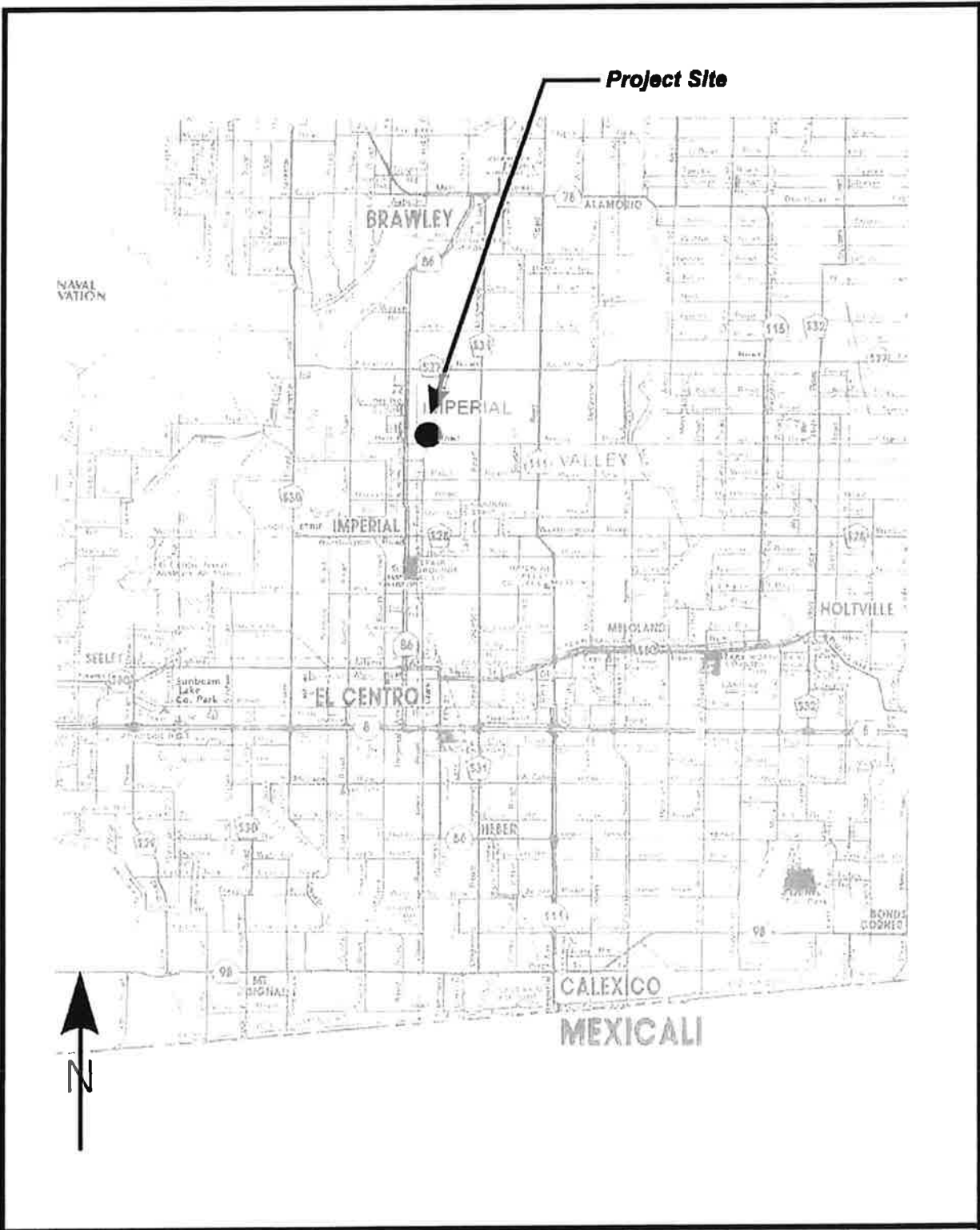

LANDMARK
Geo Engineers and Geologists

Project No.: LE18215

Vicinity Map

Plate
A-1

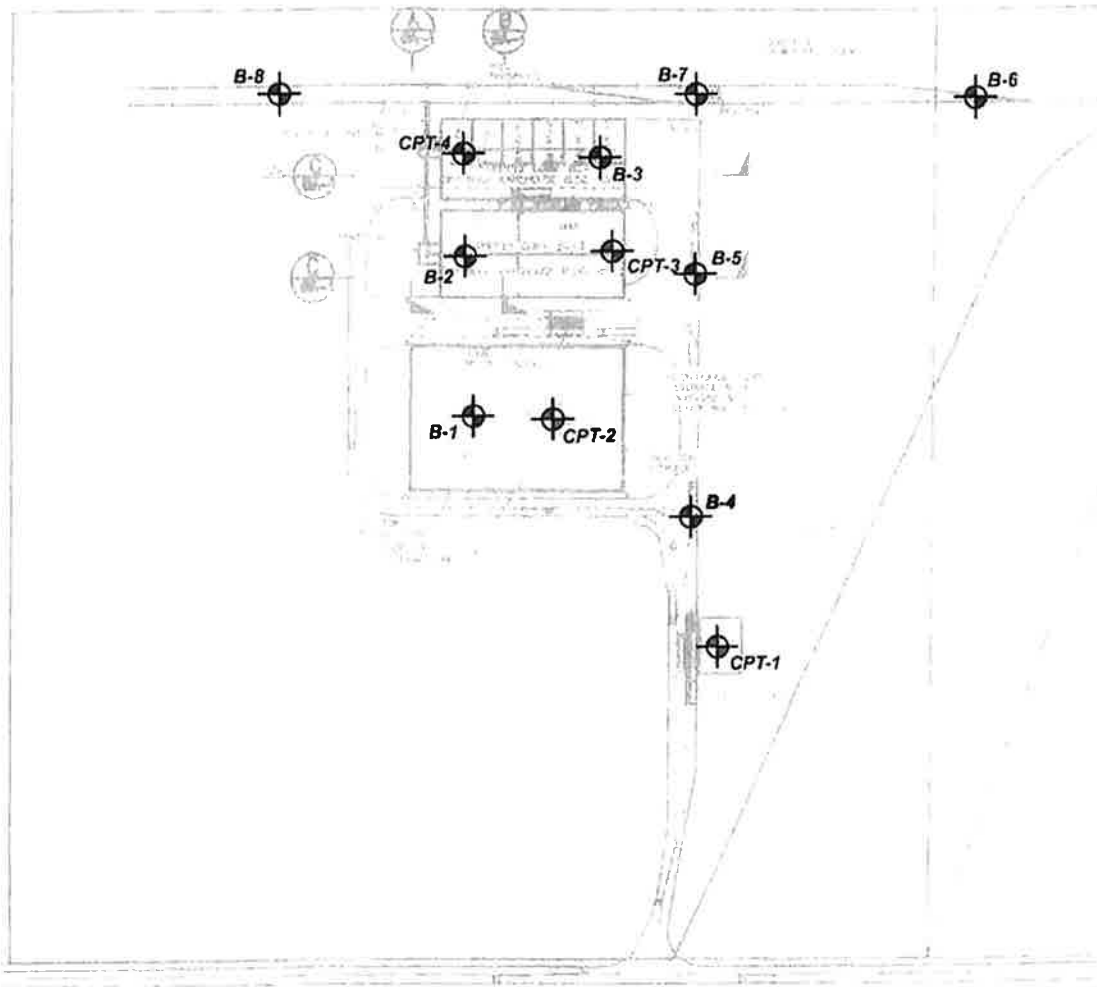

-  *Approximate Boring Location*
-  *Approximate CPT Sounding Location*

(Site and Exploration from Landmark Consultants Report LCI LE07436, dated January 18, 2008)

LANDMARK
 Geo-Engineers and Geologists
 Project No.: LE18215

Site and Exploration Map

**Plate
 A-2**



LANDMARK
Geo-Engineers and Geologists

Project No.: LE18215

Soil Survey Map

Plate
A-3

Soil Survey of
IMPERIAL COUNTY
CALIFORNIA
IMPERIAL VALLEY AREA

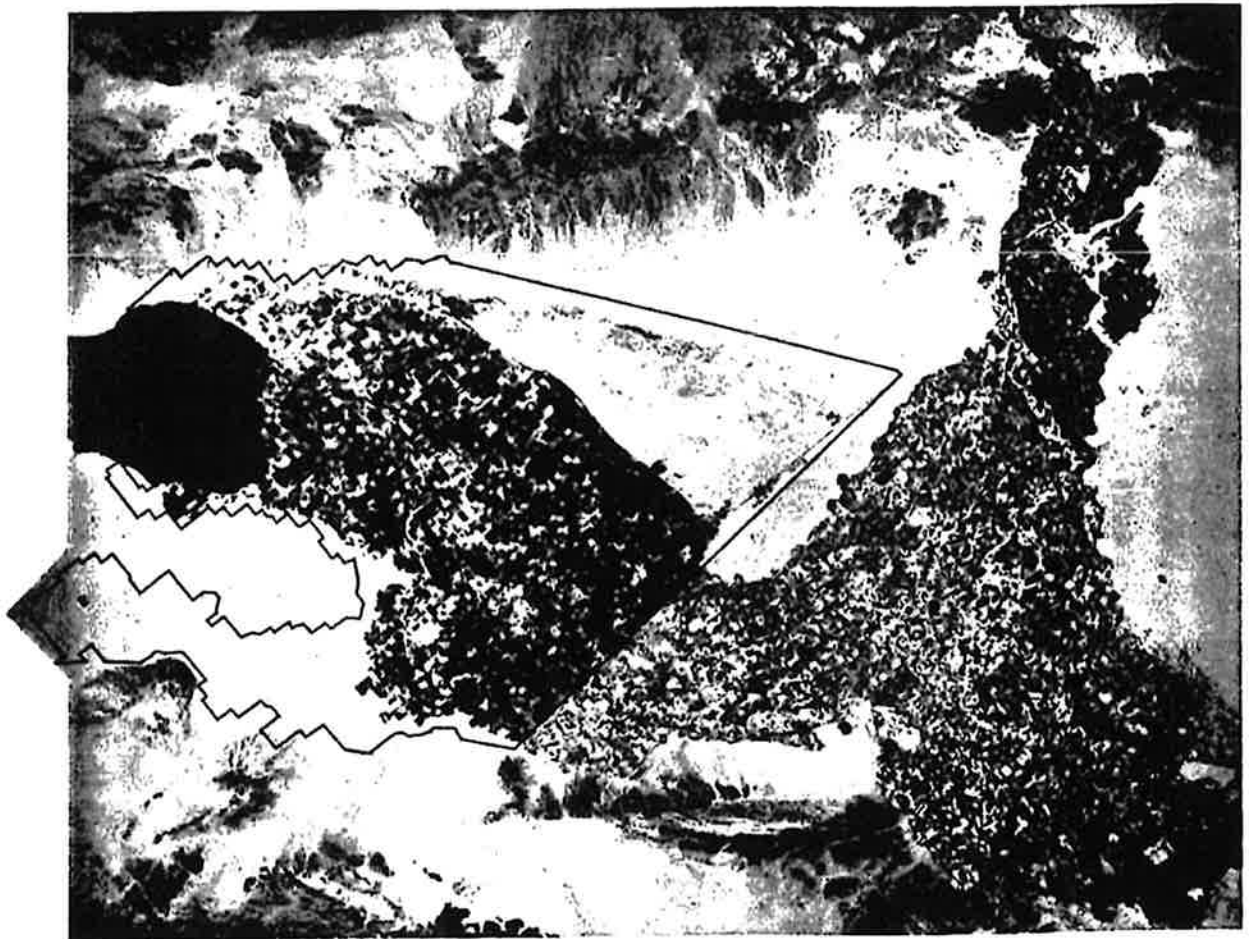

United States Department of Agriculture Soil Conservation Service
in cooperation with
University of California Agricultural Experiment Station
and
Imperial Irrigation District

TABLE 11.--ENGINEERING INDEX PROPERTIES

[The symbol > means more than. Absence of an entry indicates that data were not estimated]

Soil name and map symbol	Depth In	USDA texture	Classification		Frag- ments > 3 inches Pet	Percentage passing sieve number--				Liquid limit Pet	Plas- ticity index
			Unified	AASHTO		4	10	40	200		
100----- Antho	0-13	Loamy fine sand	SM	A-2	0	100	100	75-85	10-30	---	NP
	13-60	Sandy loam, fine sandy loam.	SM	A-2, A-4	0	90-100	75-95	50-60	15-40	---	NP
101*: Antho-----	0-8	Loamy fine sand	SM	A-2	0	100	100	75-85	10-30	---	NP
	8-60	Sandy loam, fine sandy loam.	SM	A-2, A-4	0	90-100	75-95	50-60	15-40	---	NP
Superstition-----	0-6	Fine sand-----	SM	A-2	0	100	95-100	70-85	15-25	---	NP
	6-60	Loamy fine sand, fine sand, sand.	SM	A-2	0	100	95-100	70-85	15-25	---	NP
102*. Badland											
103----- Carsitas	0-10	Gravelly sand----	SP, SP-SM	A-1, A-2	0-5	60-90	50-85	30-55	0-10	---	NP
	10-60	Gravelly sand, gravelly coarse sand, sand.	SP, SP-SM	A-1	0-5	60-90	50-85	25-50	0-10	---	NP
104* Fluvaquents											
105----- Glenbar	0-13	Clay loam-----	CL	A-6	0	100	100	90-100	70-95	35-45	15-30
	13-60	Clay loam, silty clay loam.	CL	A-6	0	100	100	90-100	70-95	35-45	15-30
106----- Glenbar	0-13	Clay loam-----	CL	A-6, A-7	0	100	100	90-100	70-95	35-45	15-25
	13-60	Clay loam, silty clay loam.	CL	A-6, A-7	0	100	100	90-100	70-95	35-45	15-25
107*----- Glenbar	0-13	Loam-----	ML, CL-ML, CL	A-4	0	100	100	100	70-80	20-30	NP-10
	13-60	Clay loam, silty clay loam.	CL	A-6, A-7	0	100	100	95-100	75-95	35-45	15-30
108----- Holtville	0-14	Loam-----	ML	A-4	0	100	100	85-100	55-95	25-35	NP-10
	14-22	Clay, silty clay	CL, CH	A-7	0	100	100	95-100	85-95	40-65	20-35
	22-60	Silt loam, very fine sandy loam.	ML	A-4	0	100	100	95-100	65-85	25-35	NP-10
109----- Holtville	0-17	Silty clay-----	CL, CH	A-7	0	100	100	95-100	85-95	40-65	20-35
	17-24	Clay, silty clay	CL, CH	A-7	0	100	100	95-100	85-95	40-65	20-35
	24-35	Silt loam, very fine sandy loam.	ML	A-4	0	100	100	95-100	65-85	25-35	NP-10
	35-60	Loamy very fine sand, loamy fine sand.	SM, ML	A-2, A-4	0	100	100	75-100	20-55	---	NP
110----- Holtville	0-17	Silty clay-----	CH, CL	A-7	0	100	100	95-100	85-95	40-65	20-35
	17-24	Clay, silty clay	CH, CL	A-7	0	100	100	95-100	85-95	40-65	20-35
	24-35	Silt loam, very fine sandy loam.	ML	A-4	0	100	100	95-100	55-85	25-35	NP-10
	35-60	Loamy very fine sand, loamy fine sand.	SM, ML	A-2, A-4	0	100	100	75-100	20-55	---	NP

See footnote at end of table.

TABLE 11.--ENGINEERING INDEX PROPERTIES--Continued

Soil name and map symbol	Depth In	USDA texture	Classification		Frag- ments > 3 inches Pct	Percentage passing sieve number--				Liquid limit Pct	Plas- ticity index
			Unified	AASHTO		4	10	40	200		
111*: Holtville-----	0-10	Silty clay loam	CL, CH	A-7	0	100	100	95-100	85-95	40-65	20-35
	10-22	Clay, silty clay	CL, CH	A-7	0	100	100	95-100	85-95	40-65	20-35
	22-60	Silt loam, very fine sandy loam.	ML	A-4	0	100	100	95-100	65-85	25-35	NP-10
Imperial-----	0-12	Silty clay loam	CL	A-7	0	100	100	100	85-95	40-50	10-20
	12-60	Silty clay loam, silty clay, clay.	CH	A-7	0	100	100	100	85-95	50-70	25-45
112----- Imperial	0-12	Silty clay-----	CH	A-7	0	100	100	100	85-95	50-70	25-45
	12-60	Silty clay loam, silty clay, clay.	CH	A-7	0	100	100	100	85-95	50-70	25-45
113----- Imperial	0-12	Silty clay-----	CH	A-7	0	100	100	100	85-95	50-70	25-45
	12-60	Silty clay, clay, silty clay loam.	CH	A-7	0	100	100	100	85-95	50-70	25-45
114----- Imperial	0-12	Silty clay-----	CH	A-7	0	100	100	100	85-95	50-70	25-45
	12-60	Silty clay loam, silty clay, clay.	CH	A-7	0	100	100	100	85-95	50-70	25-45
115*: Imperial-----	0-12	Silty clay loam	CL	A-7	0	100	100	100	85-95	40-50	10-20
	12-60	Silty clay loam, silty clay, clay.	CH	A-7	0	100	100	100	85-95	50-70	25-45
Glenbar-----	0-13	Silty clay loam	CL	A-6, A-7	0	100	100	90-100	70-95	35-45	15-25
	13-60	Clay loam, silty clay loam.	CL	A-6, A-7	0	100	100	90-100	70-95	35-45	15-25
116*: Imperial-----	0-13	Silty clay loam	CL	A-7	0	100	100	100	85-95	40-50	10-20
	13-60	Silty clay loam, silty clay, clay.	CH	A-7	0	100	100	100	85-95	50-70	25-45
Glenbar-----	0-13	Silty clay loam	CL	A-6, A-7	0	100	100	90-100	70-95	35-45	15-25
	13-60	Clay loam, silty clay loam.	CL	A-6	0	100	100	90-100	70-95	35-45	15-30
117, 118----- Indio	0-12	Loam-----	ML	A-4	0	95-100	95-100	85-100	75-90	20-30	NP-5
	12-72	Stratified loamy very fine sand to silt loam.	ML	A-4	0	95-100	95-100	85-100	75-90	20-30	NP-5
119*: Indio-----	0-12	Loam-----	ML	A-4	0	95-100	95-100	85-100	75-90	20-30	NP-5
	12-72	Stratified loamy very fine sand to silt loam.	ML	A-4	0	95-100	95-100	85-100	75-90	20-30	NP-5
Vint-----	0-10	Loamy fine sand	SM	A-2	0	95-100	95-100	70-80	25-35	---	NP
	10-60	Loamy sand, loamy fine sand.	SM	A-2	0	95-100	95-100	70-80	20-30	---	NP
120*: Laveen-----	0-12	Loam-----	ML, CL-ML	A-4	0	100	95-100	75-85	55-65	20-30	NP-10
	12-60	Loam, very fine sandy loam.	ML, CL-ML	A-4	0	95-100	85-95	70-80	55-65	15-25	NP-10

See footnote at end of table.

TABLE 11.--ENGINEERING INDEX PROPERTIES--Continued

Soil name and map symbol	Depth in	USDA texture	Classification		Frag- ments > 3 inches Pct	Percentage passing -- sieve number--				Liquid limit Pct	Plas- ticity Index
			Unified	AASHTO		4	10	40	200		
121----- Meloland	0-12	Fine sand-----	SM, SP-SM	A-2, A-3	0	95-100	90-100	75-100	5-30	---	NP
	12-26	Stratified loamy fine sand to silt loam.	ML	A-4	0	100	100	90-100	50-65	25-35	NP-10
	26-71	Clay, silty clay, silty clay loam.	CL, CH	A-7	0	100	100	95-100	85-95	40-65	20-40
122----- Meloland	0-12	Very fine sandy loam.	ML	A-4	0	95-100	95-100	95-100	55-85	25-35	NP-10
	12-26	Stratified loamy fine sand to silt loam.	ML	A-4	0	100	100	90-100	50-70	25-35	NP-10
	26-71	Clay, silty clay, silty clay loam.	CH, CL	A-7	0	100	100	95-100	85-95	40-65	20-40
123*: Meloland-----	0-12	Loam-----	ML	A-4	0	95-100	95-100	95-100	55-85	25-35	NP-10
	12-26	Stratified loamy fine sand to silt loam.	ML	A-4	0	100	100	90-100	50-70	25-35	NP-10
	26-38	Clay, silty clay, silty clay loam.	CH, CL	A-7	0	100	100	95-100	85-95	40-65	20-40
	38-60	Stratified silt loam to loamy fine sand.	SM, ML	A-4	0	100	100	75-100	35-55	25-35	NP-10
Holtville-----	0-12	Loam-----	ML	A-4	0	100	100	85-100	55-95	25-35	NP-10
	12-24	Clay, silty clay	CH, CL	A-7	0	100	100	95-100	85-95	40-65	20-35
	24-36	Silt loam, very fine sandy loam.	ML	A-4	0	100	100	95-100	55-85	25-35	NP-10
	36-60	Loamy very fine sand, loamy fine sand.	SM, ML	A-2, A-4	0	100	100	75-100	20-55	---	NP
124, 125----- Niland	0-23	Gravelly sand---	SM, SP-SM	A-2, A-3	0	90-100	70-95	50-65	5-25	---	NP
	23-60	Silty clay, clay, clay loam.	CL, CH	A-7	0	100	100	85-100	80-95	40-65	20-40
126----- Niland	0-23	Fine sand-----	SM, SP-SM	A-2, A-3	0	90-100	90-100	50-65	5-25	---	NP
	23-60	Silty clay-----	CL, CH	A-7	0	100	100	85-100	80-95	40-65	20-40
127----- Niland	0-23	Loamy fine sand	SM	A-2	0	90-100	90-100	50-65	15-30	---	NP
	23-60	Silty clay-----	CL, CH	A-7	0	100	100	85-100	80-95	40-65	20-40
128*: Niland-----	0-23	Gravelly sand---	SM, SP-SM	A-2, A-3	0	90-100	70-95	50-65	5-25	---	NP
	23-60	Silty clay, clay, clay loam.	CL, CH	A-7	0	100	100	85-100	80-100	40-65	20-40
Imperial-----	0-12	Silty clay-----	CH	A-7	0	100	100	100	85-95	50-70	25-45
	12-60	Silty clay loam, silty clay, clay.	CH	A-7	0	100	100	100	85-95	50-70	25-45
129*: Pits	0-27	Sand-----	SP-SM	A-3,	0	100	80-100	40-70	5-15	---	NP
130, 131----- Rositas	27-60	Sand, fine sand, loamy sand.	SM, SP-SM	A-3, A-1, A-2, A-2, A-1	0	100	80-100	40-85	5-30	---	NP

See footnote at end of table.

TABLE 11.--ENGINEERING INDEX PROPERTIES--Continued

Soil name and map symbol	Depth In	USDA texture	Classification		Frag- ments > 3 inches Pct	Percentage passing sieve number--				Liquid limit Pct	Plas- ticity index
			Unified	AASHTO		4	10	40	200		
132, 133, 134, 135- Rositas	0-9	Fine sand-----	SM	A-3, A-2	0	100	80-100	50-80	10-25	---	NP
	9-60	Sand, fine sand, loamy sand.	SM, SP-SM	A-3, A-2, A-1	0	100	80-100	40-85	5-30	---	NP
136----- Rositas	0-4	Loamy fine sand	SM	A-1, A-2	0	100	80-100	40-85	10-35	---	NP
	4-60	Sand, fine sand, loamy sand.	SM, SP-SM	A-3, A-2, A-1	0	100	80-100	40-85	5-30	---	NP
137----- Rositas	0-12	Silt loam-----	ML	A-4	0	100	100	90-100	70-90	20-30	NP-5
	12-60	Sand, fine sand, loamy sand.	SM, SP-SM	A-3, A-2, A-1	0	100	80-100	40-85	5-30	---	NP
138*: Rositas-----	0-4	Loamy fine sand	SM	A-1, A-2	0	100	80-100	40-85	10-35	---	NP
	4-60	Sand, fine sand, loamy sand.	SM, SP-SM	A-3, A-2, A-1	0	100	80-100	40-85	5-30	---	NP
Superstition-----	0-6	Loamy fine sand	SM	A-2	0	100	95-100	70-85	15-25	---	NP
	6-60	Loamy fine sand, fine sand, sand.	SM	A-2	0	100	95-100	70-85	15-25	---	NP
139----- Superstition	0-6	Loamy fine sand	SM	A-2	0	100	95-100	70-85	15-25	---	NP
	6-60	Loamy fine sand, fine sand, sand.	SM	A-2	0	100	95-100	70-85	15-25	---	NP
140*: Torriorthents Rock outcrop											
141*: Torriorthents Orthids											
142----- Vint	0-10	Loamy very fine sand.	SM, ML	A-4	0	100	100	85-95	40-65	15-25	NP-5
	10-60	Loamy fine sand	SM	A-2	0	95-100	95-100	70-80	20-30	---	NP
143----- Vint	0-12	Fine sandy loam	ML, CL-ML, SM, SM-SC	A-4	0	100	100	75-85	45-55	15-25	NP-5
	12-60	Loamy sand, loamy fine sand.	SM	A-2	0	95-100	95-100	70-80	20-30	---	NP
144*: Vint-----	0-10	Very fine sandy loam.	SM, ML	A-4	0	100	100	85-95	40-65	15-25	NP-5
	10-40	Loamy fine sand	SM	A-2	0	95-100	95-100	70-80	20-30	---	NP
	40-60	Silty clay-----	CL, CH	A-7	0	100	100	95-100	85-95	40-65	20-35
Indio-----	0-12	Very fine sandy loam.	ML	A-4	0	95-100	95-100	85-100	75-90	20-30	NP-5
	12-40	Stratified loamy very fine sand to silt loam.	ML	A-4	0	95-100	95-100	85-100	75-90	20-30	NP-5
	40-72	Silty clay-----	CL, CH	A-7	0	100	100	95-100	85-95	40-65	20-35

* See description of the map unit for composition and behavior characteristics of the map unit.

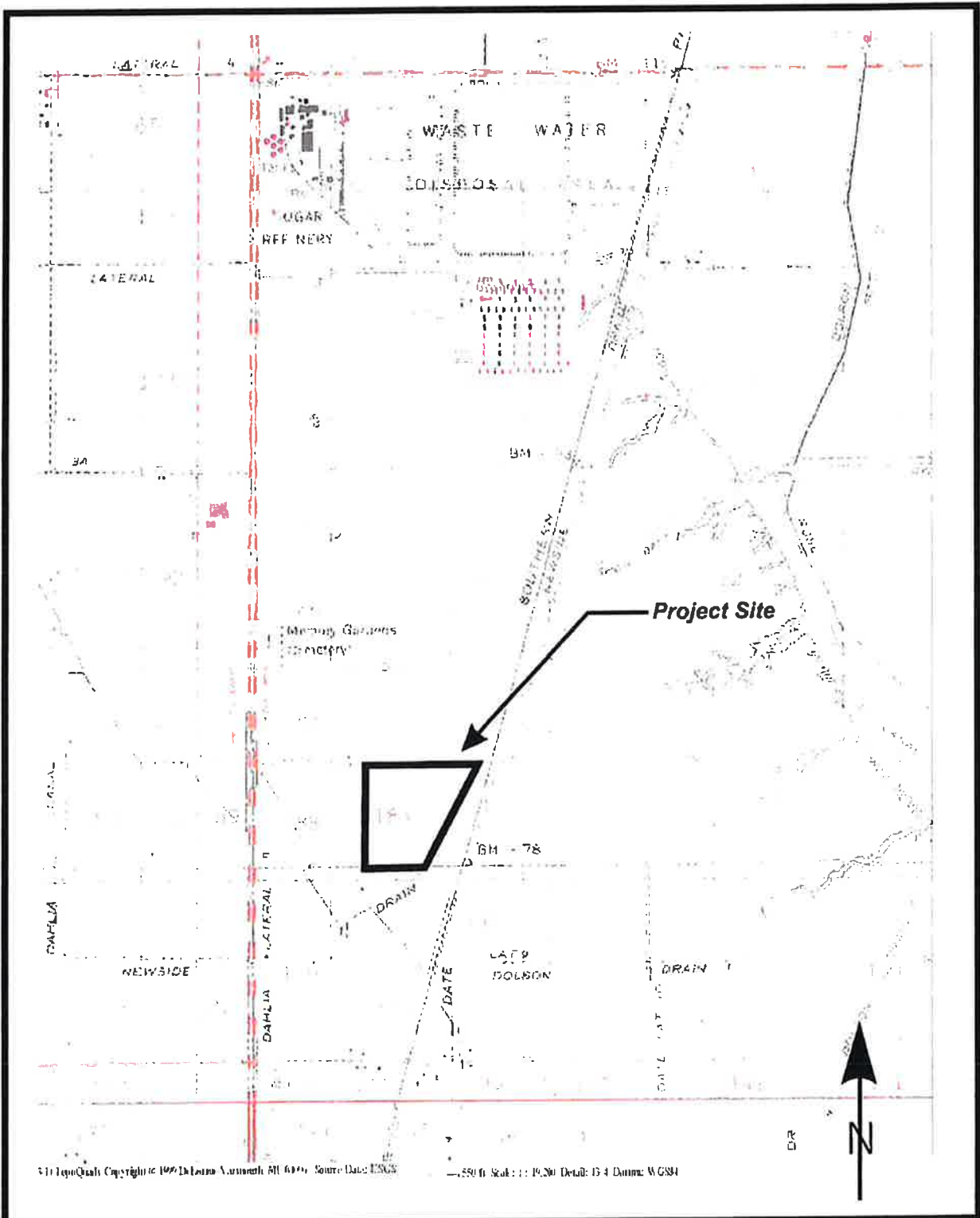

LANDMARK
 Geo-Engineers and Geologists
 Project No.: LE18215

Topographic Map

Plate
 A-4

EEC ORIGINAL PKG

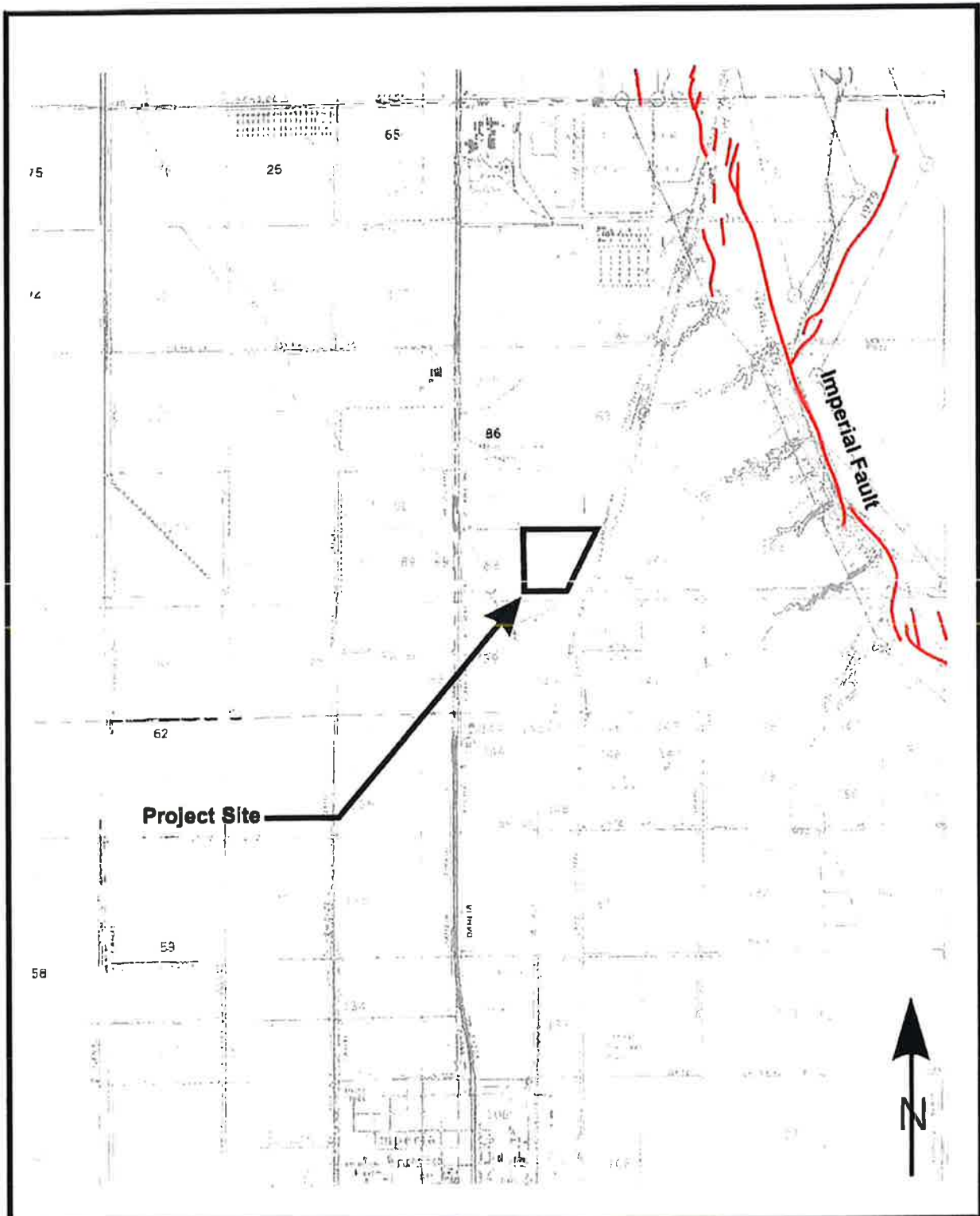

LANDMARK
Geo Engineers and Geologists
Project No.: LE18215

A-P Earthquake Fault Hazard Map

**Plate
A-5**

APPENDIX B

LIQUEFACTION ANALYSIS REPORT

Project title : JR Simplot Fertilizer Facility

Location : Brawley, CA

CPT file : CPT-1

Input parameters and analysis data

Analysis method:	NCEER (1998)	G.W.T. (in-situ):	5.00 ft	Use fill:	No	Clay like behavior	
Fines correction method:	NCEER (1998)	G.W.T. (earthq.):	5.00 ft	Fill height:	N/A	applied:	Sands only
Points to test:	Based on Ic value	Average results interval:	3	Fill weight:	N/A	Limit depth applied:	No
Earthquake magnitude M_w :	7.00	Ic cut-off value:	2.60	Trans. detect. applied:	Yes	Limit depth:	N/A
Peak ground acceleration:	0.82	Unit weight calculation:	Based on SBT	K_0 applied:	Yes	MSF method:	Method based

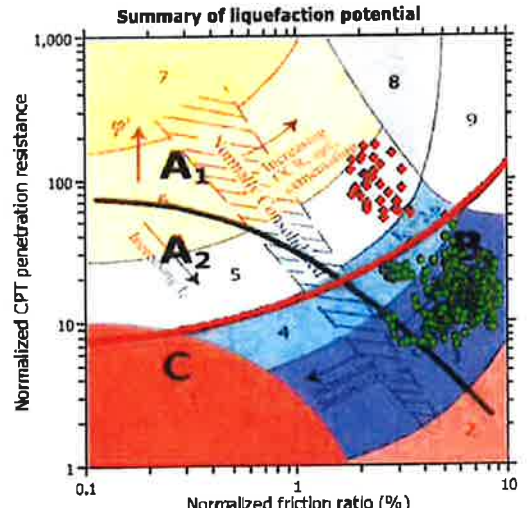
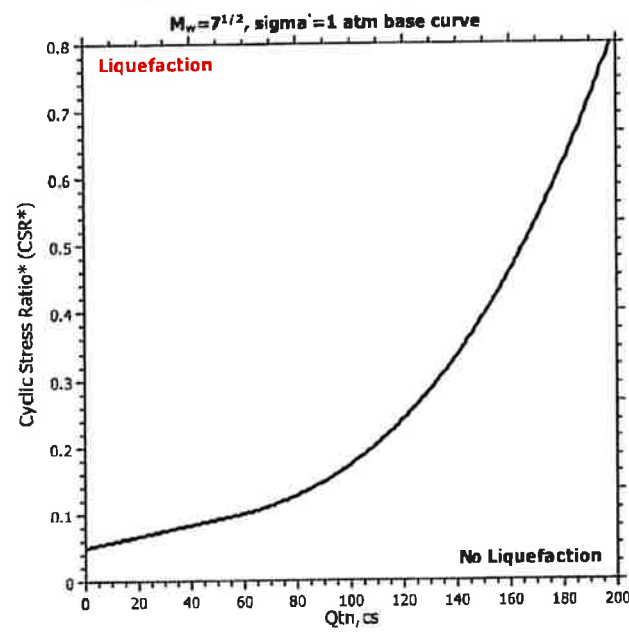
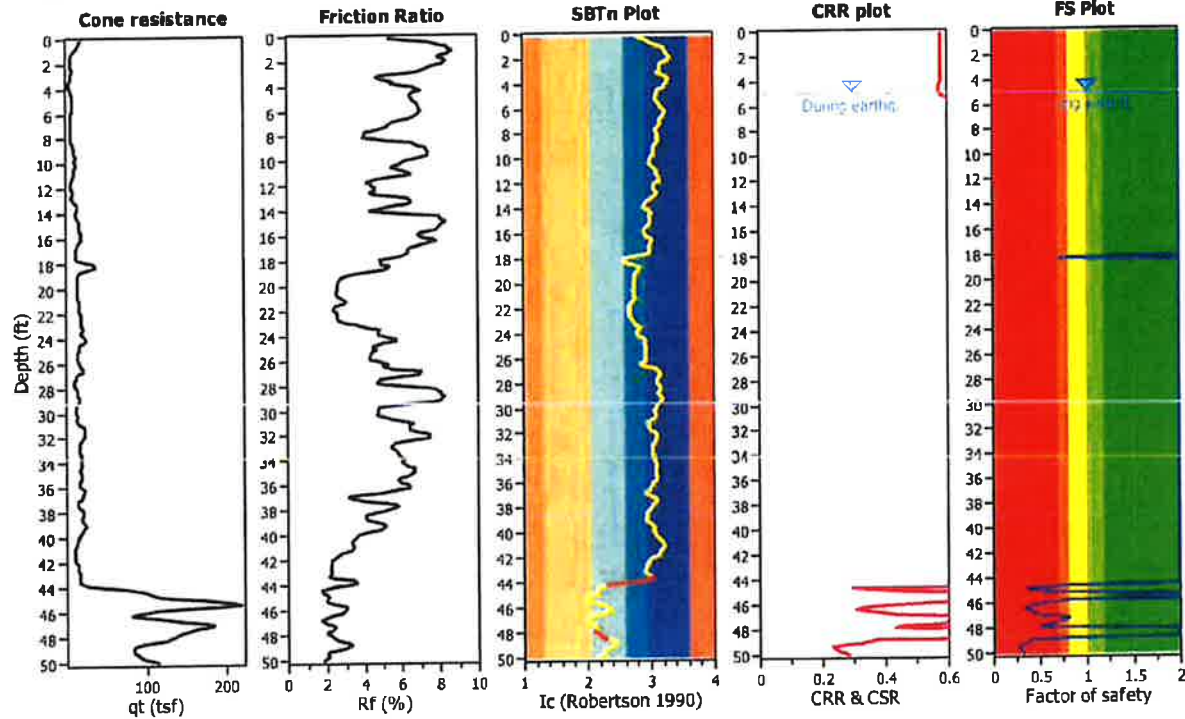

Zone A1: Cyclic liquefaction likely depending on size and duration of cyclic loading
 Zone A2: Cyclic liquefaction and strength loss likely depending on loading and ground geometry
 Zone B: Liquefaction and post-earthquake strength loss unlikely, check cyclic softening
 Zone C: Cyclic liquefaction and strength loss possible depending on soil plasticity, brittleness/sensitivity, strain to peak undrained strength and ground geometry

CPT basic interpretation plots

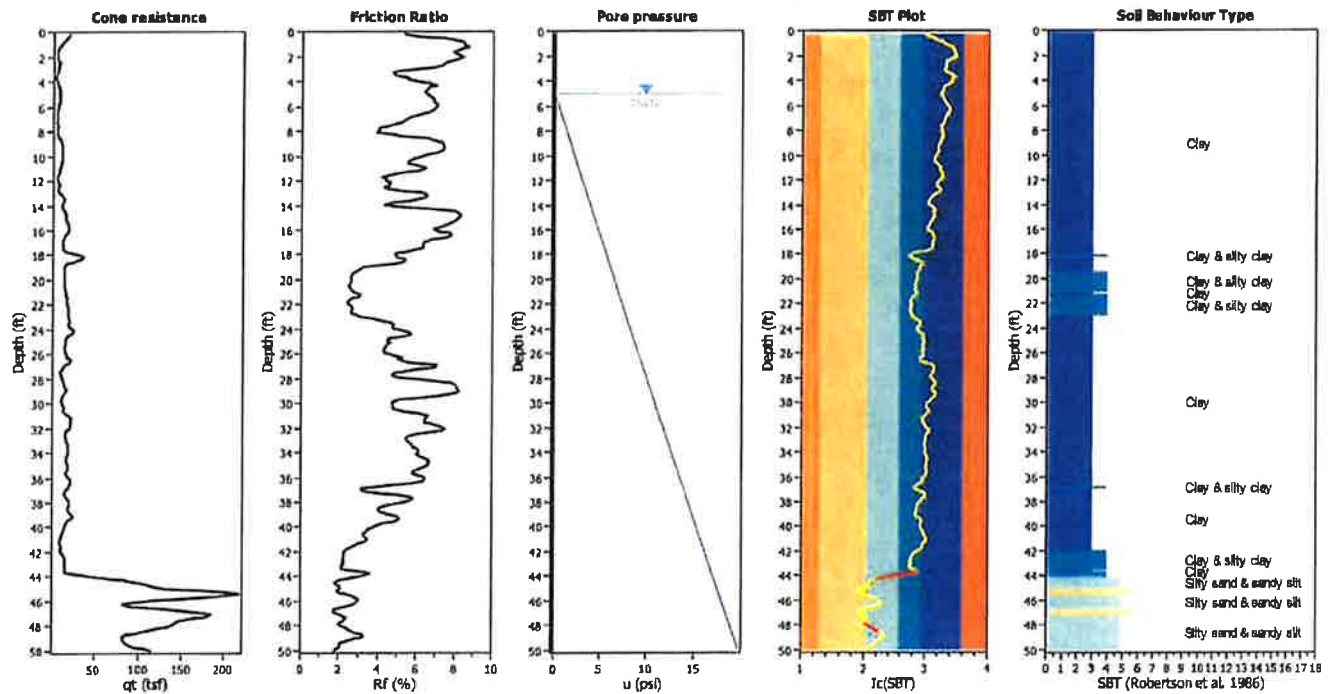

Input parameters and analysis data

Analysis method:	NCEER (1996)	Depth to water table (ortho.):	5.00 ft.	Fill weight:	N/A
Flines correction method:	NCEER (1996)	Average results interval:	3	Transition detect. applied:	Yes
Points to test:	Based on Ic value	Ic cut-off value:	2.60	K _o applied:	Yes
Earthquake magnitude M _w :	7.00	Unit weight calculation:	Based on SBT	Clay like behavior applied:	Sands only
Peak ground acceleration:	0.82	Use fill:	No	Limit depth applied:	No
Depth to water table (Instlu):	5.00 ft	Fill height:	N/A	Limit depth:	N/A

SBT legend

- | | | |
|---------------------------|-----------------------------|----------------------------|
| 1. Sensitive fine grained | 4. Clayey silt to silty | 7. Gravely sand to sand |
| 2. Organic material | 5. Silty sand to sandy silt | 8. Very stiff sand to |
| 3. Clay to silty clay | 6. Clean sand to silty sand | 9. Very stiff fine grained |

Estimation of post-earthquake settlements

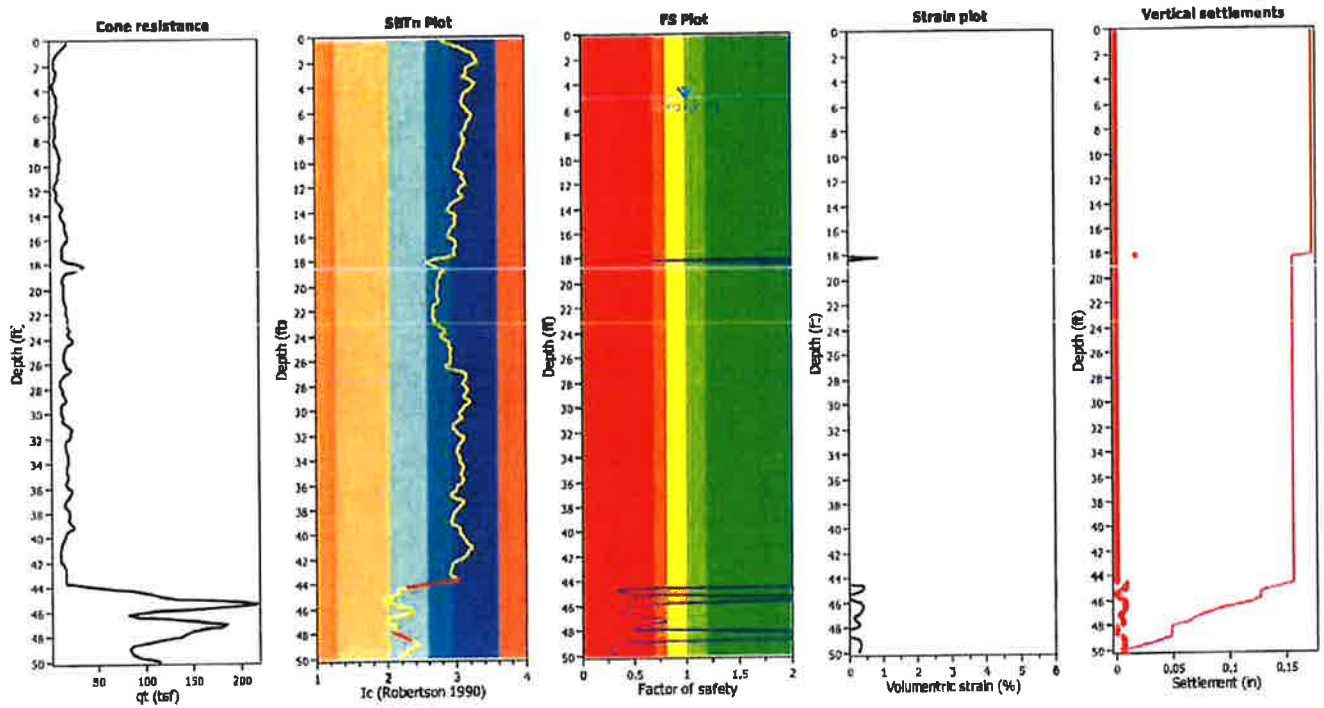

Abbreviations

- q_t : Total cone resistance (cone resistance q_c corrected for pore water effects)
- I_c : Soil Behaviour Type Index
- FS: Calculated Factor of Safety against liquefaction
- Volumetric strain: Post-liquefaction volumetric strain

:: Post-earthquake settlement due to soil liquefaction ::

Depth (ft)	Q _{m,cs}	FS	e _v (%)	DF	Settlement (In)	Depth (ft)	Q _{m,cs}	FS	e _v (%)	DF	Settlement (In)
5.09	113.09	2.00	0.00	0.91	0.00	5.25	114.39	2.00	0.00	0.91	0.00
5.41	113.17	2.00	0.00	0.91	0.00	5.58	110.46	2.00	0.00	0.91	0.00
5.74	108.15	2.00	0.00	0.90	0.00	5.91	104.86	2.00	0.00	0.90	0.00
6.07	99.86	2.00	0.00	0.90	0.00	6.23	97.03	2.00	0.00	0.89	0.00
6.40	94.18	2.00	0.00	0.89	0.00	6.56	92.81	2.00	0.00	0.89	0.00
6.73	90.30	2.00	0.00	0.89	0.00	6.89	89.52	2.00	0.00	0.88	0.00
7.05	88.30	2.00	0.00	0.88	0.00	7.22	86.81	2.00	0.00	0.88	0.00
7.38	84.63	2.00	0.00	0.87	0.00	7.55	82.11	2.00	0.00	0.87	0.00
7.71	78.25	2.00	0.00	0.87	0.00	7.87	76.48	2.00	0.00	0.87	0.00
8.04	75.69	2.00	0.00	0.86	0.00	8.20	82.36	2.00	0.00	0.86	0.00
8.37	93.26	2.00	0.00	0.86	0.00	8.53	107.48	2.00	0.00	0.86	0.00
8.69	117.97	2.00	0.00	0.85	0.00	8.86	125.30	2.00	0.00	0.85	0.00
9.02	130.05	2.00	0.00	0.85	0.00	9.19	133.74	2.00	0.00	0.84	0.00
9.35	136.14	2.00	0.00	0.84	0.00	9.51	133.88	2.00	0.00	0.84	0.00
9.68	128.88	2.00	0.00	0.84	0.00	9.84	124.74	2.00	0.00	0.83	0.00
10.01	122.93	2.00	0.00	0.83	0.00	10.17	120.02	2.00	0.00	0.83	0.00
10.33	115.38	2.00	0.00	0.82	0.00	10.50	112.14	2.00	0.00	0.82	0.00
10.66	112.30	2.00	0.00	0.82	0.00	10.83	113.79	2.00	0.00	0.82	0.00
10.99	113.48	2.00	0.00	0.81	0.00	11.15	108.81	2.00	0.00	0.81	0.00
11.32	96.65	2.00	0.00	0.81	0.00	11.48	84.04	2.00	0.00	0.81	0.00
11.65	76.82	2.00	0.00	0.80	0.00	11.81	79.17	2.00	0.00	0.80	0.00
11.98	84.53	2.00	0.00	0.80	0.00	12.14	90.45	2.00	0.00	0.79	0.00
12.30	91.52	2.00	0.00	0.79	0.00	12.47	87.96	2.00	0.00	0.79	0.00
12.63	85.97	2.00	0.00	0.79	0.00	12.80	94.79	2.00	0.00	0.78	0.00
12.96	110.97	2.00	0.00	0.78	0.00	13.12	127.31	2.00	0.00	0.78	0.00
13.29	136.16	2.00	0.00	0.77	0.00	13.45	135.28	2.00	0.00	0.77	0.00
13.62	125.26	2.00	0.00	0.77	0.00	13.78	112.51	2.00	0.00	0.77	0.00
13.94	105.58	2.00	0.00	0.76	0.00	14.11	116.80	2.00	0.00	0.76	0.00
14.27	135.93	2.00	0.00	0.76	0.00	14.44	155.80	2.00	0.00	0.76	0.00
14.60	165.55	2.00	0.00	0.75	0.00	14.76	167.50	2.00	0.00	0.75	0.00
14.93	165.14	2.00	0.00	0.75	0.00	15.09	164.98	2.00	0.00	0.74	0.00
15.26	167.32	2.00	0.00	0.74	0.00	15.42	169.99	2.00	0.00	0.74	0.00
15.58	168.07	2.00	0.00	0.74	0.00	15.75	163.72	2.00	0.00	0.73	0.00
15.91	162.47	2.00	0.00	0.73	0.00	16.08	164.07	2.00	0.00	0.73	0.00
16.24	165.07	2.00	0.00	0.72	0.00	16.40	157.48	2.00	0.00	0.72	0.00
16.57	146.49	2.00	0.00	0.72	0.00	16.73	136.15	2.00	0.00	0.72	0.00
16.90	132.58	2.00	0.00	0.71	0.00	17.06	133.20	2.00	0.00	0.71	0.00
17.22	133.35	2.00	0.00	0.71	0.00	17.39	131.00	2.00	0.00	0.71	0.00
17.55	128.93	2.00	0.00	0.70	0.00	17.72	138.06	2.00	0.00	0.70	0.00
17.88	152.47	2.00	0.00	0.70	0.00	18.04	171.37	2.00	0.00	0.69	0.00
18.21	177.91	0.65	0.91	0.69	0.02	18.37	175.70	2.00	0.00	0.69	0.00
18.54	154.72	2.00	0.00	0.69	0.00	18.70	130.05	2.00	0.00	0.68	0.00
18.86	106.22	2.00	0.00	0.68	0.00	19.03	95.70	2.00	0.00	0.68	0.00
19.19	91.59	2.00	0.00	0.67	0.00	19.36	89.06	2.00	0.00	0.67	0.00
19.52	87.08	2.00	0.00	0.67	0.00	19.69	85.94	2.00	0.00	0.67	0.00
19.85	85.87	2.00	0.00	0.66	0.00	20.01	86.14	2.00	0.00	0.66	0.00
20.18	85.97	2.00	0.00	0.66	0.00	20.34	85.41	2.00	0.00	0.66	0.00
20.51	84.61	2.00	0.00	0.65	0.00	20.67	84.82	2.00	0.00	0.65	0.00

:: Post-earthquake settlement due to soil liquefaction :: (continued)

Depth (ft)	Q _{m,cs}	FS	e _v (%)	DF	Settlement (in)	Depth (ft)	Q _{m,cs}	FS	e _v (%)	DF	Settlement (in)
20.83	86.38	2.00	0.00	0.65	0.00	21.00	90.85	2.00	0.00	0.64	0.00
21.16	95.46	2.00	0.00	0.64	0.00	21.33	95.89	2.00	0.00	0.64	0.00
21.49	91.38	2.00	0.00	0.64	0.00	21.65	87.10	2.00	0.00	0.63	0.00
21.82	85.90	2.00	0.00	0.63	0.00	21.98	89.47	2.00	0.00	0.63	0.00
22.15	91.08	2.00	0.00	0.62	0.00	22.31	92.71	2.00	0.00	0.62	0.00
22.47	91.97	2.00	0.00	0.62	0.00	22.64	91.62	2.00	0.00	0.62	0.00
22.80	93.35	2.00	0.00	0.61	0.00	22.97	99.74	2.00	0.00	0.61	0.00
23.13	111.58	2.00	0.00	0.61	0.00	23.29	121.23	2.00	0.00	0.61	0.00
23.46	125.14	2.00	0.00	0.60	0.00	23.62	122.82	2.00	0.00	0.60	0.00
23.79	125.16	2.00	0.00	0.60	0.00	23.95	133.57	2.00	0.00	0.59	0.00
24.11	144.78	2.00	0.00	0.59	0.00	24.28	145.22	2.00	0.00	0.59	0.00
24.44	134.81	2.00	0.00	0.59	0.00	24.61	118.94	2.00	0.00	0.58	0.00
24.77	110.96	2.00	0.00	0.58	0.00	24.93	109.05	2.00	0.00	0.58	0.00
25.10	109.24	2.00	0.00	0.57	0.00	25.26	106.71	2.00	0.00	0.57	0.00
25.43	105.19	2.00	0.00	0.57	0.00	25.59	103.47	2.00	0.00	0.57	0.00
25.75	104.53	2.00	0.00	0.56	0.00	25.92	105.60	2.00	0.00	0.56	0.00
26.08	113.24	2.00	0.00	0.56	0.00	26.25	121.75	2.00	0.00	0.56	0.00
26.41	127.47	2.00	0.00	0.55	0.00	26.57	131.35	2.00	0.00	0.55	0.00
26.74	131.42	2.00	0.00	0.55	0.00	26.90	128.46	2.00	0.00	0.54	0.00
27.07	118.82	2.00	0.00	0.54	0.00	27.23	106.92	2.00	0.00	0.54	0.00
27.40	96.45	2.00	0.00	0.54	0.00	27.56	90.19	2.00	0.00	0.53	0.00
27.72	91.34	2.00	0.00	0.53	0.00	27.89	97.96	2.00	0.00	0.53	0.00
28.05	109.35	2.00	0.00	0.52	0.00	28.22	121.20	2.00	0.00	0.52	0.00
28.38	127.20	2.00	0.00	0.52	0.00	28.54	131.09	2.00	0.00	0.52	0.00
28.71	137.61	2.00	0.00	0.51	0.00	28.87	142.99	2.00	0.00	0.51	0.00
29.04	139.24	2.00	0.00	0.51	0.00	29.20	126.52	2.00	0.00	0.51	0.00
29.36	114.06	2.00	0.00	0.50	0.00	29.53	103.56	2.00	0.00	0.50	0.00
29.69	94.73	2.00	0.00	0.50	0.00	29.86	90.80	2.00	0.00	0.49	0.00
30.02	94.24	2.00	0.00	0.49	0.00	30.18	97.79	2.00	0.00	0.49	0.00
30.35	98.13	2.00	0.00	0.49	0.00	30.51	97.55	2.00	0.00	0.48	0.00
30.68	104.68	2.00	0.00	0.48	0.00	30.84	118.88	2.00	0.00	0.48	0.00
31.00	135.05	2.00	0.00	0.47	0.00	31.17	141.49	2.00	0.00	0.47	0.00
31.33	140.33	2.00	0.00	0.47	0.00	31.50	137.97	2.00	0.00	0.47	0.00
31.66	140.75	2.00	0.00	0.46	0.00	31.82	145.24	2.00	0.00	0.46	0.00
31.99	142.54	2.00	0.00	0.46	0.00	32.15	133.27	2.00	0.00	0.46	0.00
32.32	121.05	2.00	0.00	0.45	0.00	32.48	112.94	2.00	0.00	0.45	0.00
32.64	109.06	2.00	0.00	0.45	0.00	32.81	109.06	2.00	0.00	0.44	0.00
32.97	110.44	2.00	0.00	0.44	0.00	33.14	113.68	2.00	0.00	0.44	0.00
33.30	117.04	2.00	0.00	0.44	0.00	33.46	119.16	2.00	0.00	0.43	0.00
33.63	120.09	2.00	0.00	0.43	0.00	33.79	120.02	2.00	0.00	0.43	0.00
33.96	120.58	2.00	0.00	0.42	0.00	34.12	119.10	2.00	0.00	0.42	0.00
34.28	118.59	2.00	0.00	0.42	0.00	34.45	118.97	2.00	0.00	0.42	0.00
34.61	121.24	2.00	0.00	0.41	0.00	34.78	121.70	2.00	0.00	0.41	0.00
34.94	122.84	2.00	0.00	0.41	0.00	35.10	121.27	2.00	0.00	0.41	0.00
35.27	118.50	2.00	0.00	0.40	0.00	35.43	111.46	2.00	0.00	0.40	0.00
35.60	108.18	2.00	0.00	0.40	0.00	35.76	112.75	2.00	0.00	0.39	0.00
35.93	122.51	2.00	0.00	0.39	0.00	36.09	130.12	2.00	0.00	0.39	0.00
36.25	130.25	2.00	0.00	0.39	0.00	36.42	122.59	2.00	0.00	0.38	0.00

:: Post-earthquake settlement due to soil liquefaction :: (continued)

Depth (ft)	Q _{tn,cs}	FS	e _v (%)	DF	Settlement (in)	Depth (ft)	Q _{tn,cs}	FS	e _v (%)	DF	Settlement (in)
36.58	110.32	2.00	0.00	0.38	0.00	36.75	94.96	2.00	0.00	0.38	0.00
36.91	84.19	2.00	0.00	0.37	0.00	37.07	80.08	2.00	0.00	0.37	0.00
37.24	86.27	2.00	0.00	0.37	0.00	37.40	97.54	2.00	0.00	0.37	0.00
37.57	108.99	2.00	0.00	0.36	0.00	37.73	115.06	2.00	0.00	0.36	0.00
37.89	113.88	2.00	0.00	0.36	0.00	38.06	107.76	2.00	0.00	0.35	0.00
38.22	101.97	2.00	0.00	0.35	0.00	38.39	97.52	2.00	0.00	0.35	0.00
38.55	96.12	2.00	0.00	0.35	0.00	38.71	98.69	2.00	0.00	0.34	0.00
38.88	106.72	2.00	0.00	0.34	0.00	39.04	114.77	2.00	0.00	0.34	0.00
39.21	116.37	2.00	0.00	0.34	0.00	39.37	108.86	2.00	0.00	0.33	0.00
39.53	99.70	2.00	0.00	0.33	0.00	39.70	91.49	2.00	0.00	0.33	0.00
39.86	86.87	2.00	0.00	0.32	0.00	40.03	81.03	2.00	0.00	0.32	0.00
40.19	76.60	2.00	0.00	0.32	0.00	40.35	73.45	2.00	0.00	0.32	0.00
40.52	71.19	2.00	0.00	0.31	0.00	40.68	69.71	2.00	0.00	0.31	0.00
40.85	68.90	2.00	0.00	0.31	0.00	41.01	67.10	2.00	0.00	0.30	0.00
41.17	65.43	2.00	0.00	0.30	0.00	41.34	63.97	2.00	0.00	0.30	0.00
41.50	62.36	2.00	0.00	0.30	0.00	41.67	60.46	2.00	0.00	0.29	0.00
41.83	58.79	2.00	0.00	0.29	0.00	41.99	60.18	2.00	0.00	0.29	0.00
42.16	63.13	2.00	0.00	0.29	0.00	42.32	64.75	2.00	0.00	0.28	0.00
42.49	65.45	2.00	0.00	0.28	0.00	42.65	65.86	2.00	0.00	0.28	0.00
42.81	66.36	2.00	0.00	0.27	0.00	42.98	67.04	2.00	0.00	0.27	0.00
43.14	66.09	2.00	0.00	0.27	0.00	43.31	64.89	2.00	0.00	0.27	0.00
43.47	67.54	2.00	0.00	0.26	0.00	43.64	79.80	2.00	0.00	0.26	0.00
43.80	100.10	2.00	0.00	0.26	0.00	43.96	115.84	2.00	0.00	0.25	0.00
44.13	120.87	2.00	0.00	0.25	0.00	44.29	123.32	2.00	0.00	0.25	0.00
44.46	124.23	2.00	0.00	0.25	0.00	44.62	132.25	0.31	0.45	0.24	0.01
44.78	144.25	0.38	0.42	0.24	0.01	44.95	157.69	0.47	0.38	0.24	0.01
45.11	183.60	0.69	0.24	0.24	0.00	45.28	212.69	2.00	0.00	0.23	0.00
45.44	229.58	2.00	0.00	0.23	0.00	45.60	221.87	2.00	0.00	0.23	0.00
45.77	197.90	0.84	0.17	0.22	0.00	45.93	169.84	0.56	0.31	0.22	0.01
46.10	145.40	0.39	0.38	0.22	0.01	46.26	137.16	0.34	0.39	0.22	0.01
46.42	134.36	0.32	0.39	0.21	0.01	46.59	141.83	0.37	0.37	0.21	0.01
46.75	156.35	0.46	0.34	0.21	0.01	46.92	176.04	0.62	0.27	0.20	0.01
47.08	190.48	0.77	0.16	0.20	0.00	47.24	194.13	0.81	0.15	0.20	0.00
47.41	186.74	0.73	0.20	0.20	0.00	47.57	170.50	0.58	0.27	0.19	0.01
47.74	158.87	0.48	0.31	0.19	0.01	47.90	155.62	0.46	0.31	0.19	0.01
48.06	157.98	2.00	0.00	0.19	0.00	48.23	155.83	2.00	0.00	0.18	0.00
48.39	150.42	2.00	0.00	0.18	0.00	48.56	147.26	2.00	0.00	0.18	0.00
48.72	147.98	2.00	0.00	0.17	0.00	48.88	147.05	0.41	0.29	0.17	0.01
49.05	137.21	0.35	0.30	0.17	0.01	49.21	126.02	0.29	0.32	0.17	0.01
49.38	117.77	0.25	0.33	0.16	0.01	49.54	119.63	0.26	0.32	0.16	0.01
49.70	123.06	0.28	0.31	0.16	0.01	49.87	127.47	0.30	0.30	0.15	0.01
50.03	130.13	0.31	0.29	0.15	0.01						

Total estimated settlement: 0.17

Abbreviations

Q_{tn,cs}: Equivalent clean sand normalized cone resistance
 FS: Factor of safety against liquefaction
 e_v (%): Post-liquefaction volumetric strain
 DF: e_v depth weighting factor
 Settlement: Calculated settlement

LIQUEFACTION ANALYSIS REPORT

Project title : JR Simplot Fertilizer Facility

Location : Brawley, CA

CPT file : CPT-2

Input parameters and analysis data

Analysis method:	NCEER (1998)	G.W.T. (In-situ):	5.00 ft	Use fill:	No	Clay like behavior	
Fines correction method:	NCEER (1998)	G.W.T. (earthq.):	5.00 ft	Fill height:	N/A	applied:	Sands only
Points to test:	Based on Ic value	Average results interval:	3	Fill weight:	N/A	Limit depth applied:	No
Earthquake magnitude M_w :	7.00	Ic cut-off value:	2.60	Trans. detect. applied:	Yes	Limit depth:	N/A
Peak ground acceleration:	0.82	Unit weight calculation:	Based on SBT	K_f applied:	Yes	MSF method:	Method based

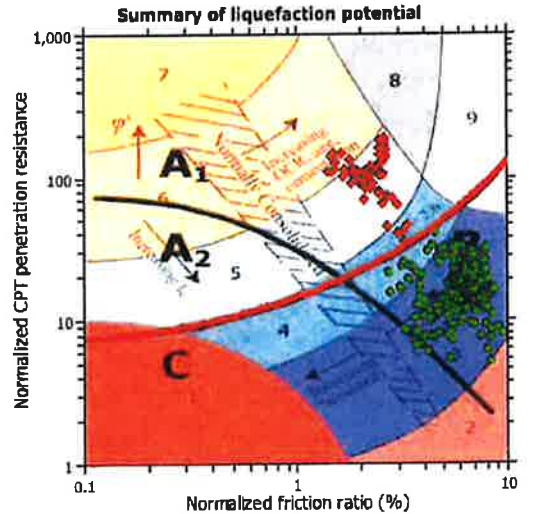
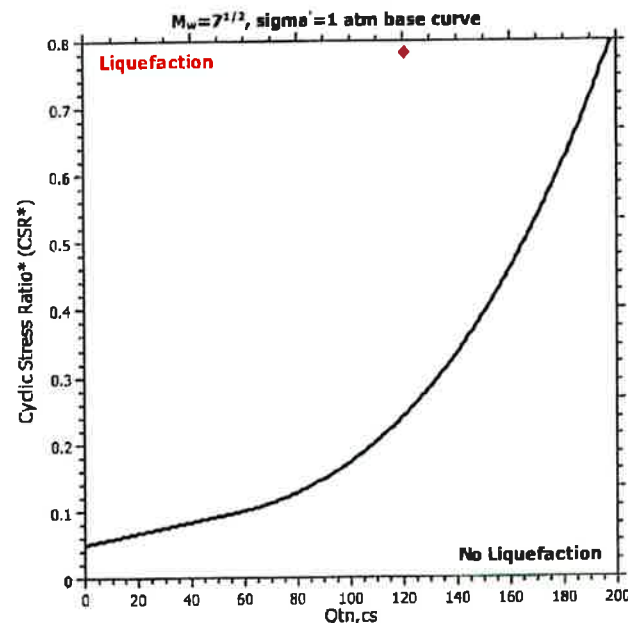
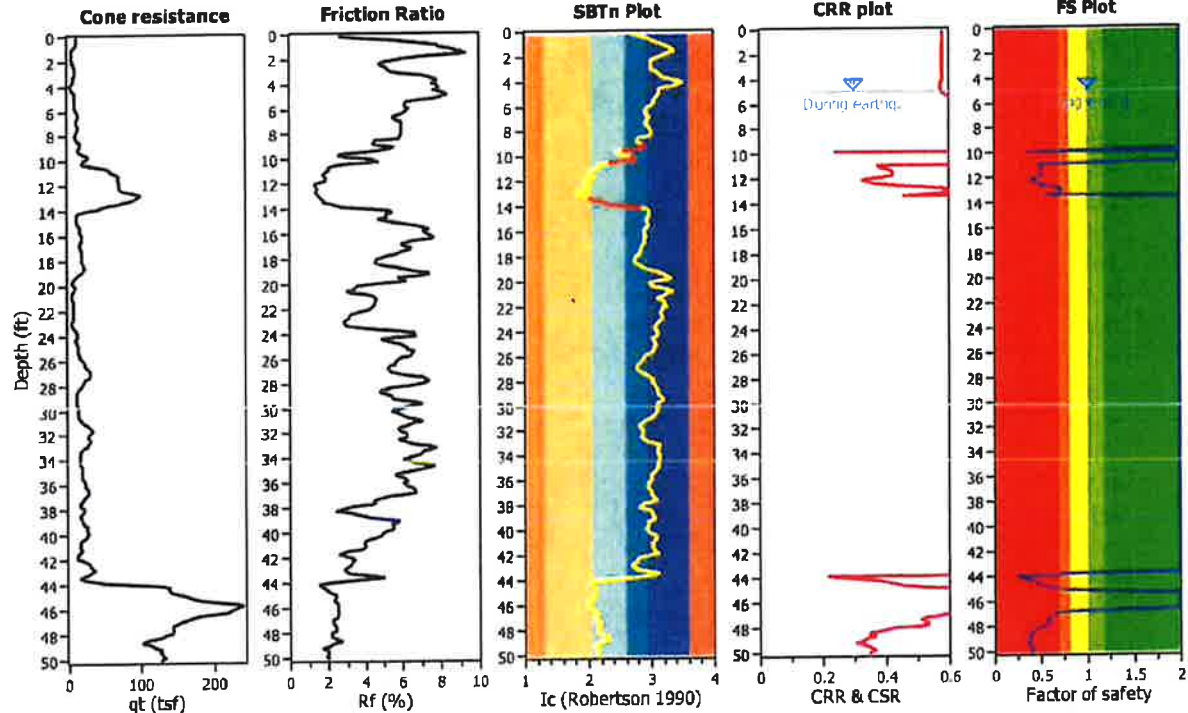

Zone A₁: Cyclic liquefaction likely depending on size and duration of cyclic loading
 Zone A₂: Cyclic liquefaction and strength loss likely depending on loading and ground geometry
 Zone B: Liquefaction and post-earthquake strength loss unlikely, check cyclic softening
 Zone C: Cyclic liquefaction and strength loss possible depending on soil plasticity, brittleness/sensitivity, strain to peak undrained strength and ground geometry

CPT basic interpretation plots

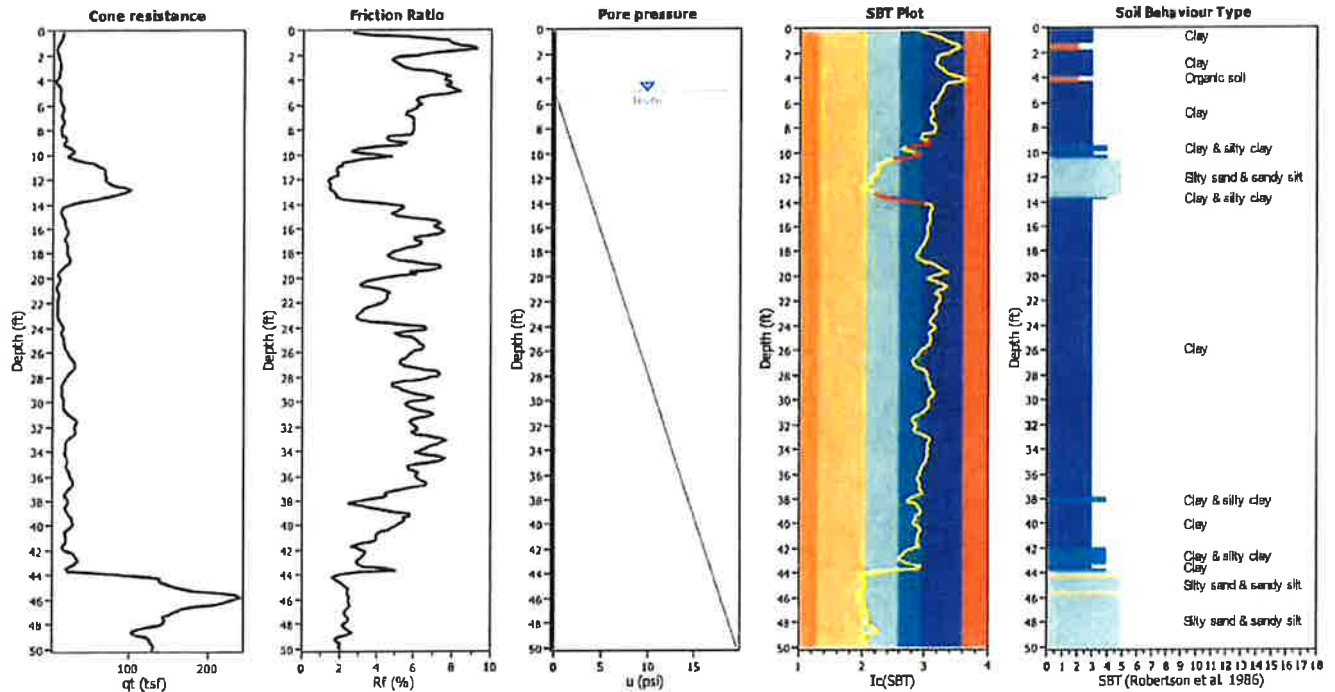

Input parameters and analysis data

Analysis method: NCEER (1998)	Depth to water table (ortho.): 5.00 ft	Fill weight: N/A
Finest correction method: NCFER (1998)	Average results interval: 3	Transition detect. applied: Yes
Points to test: Based on Ic value	Ic cut-off value: 2.60	K_v applied: Yes
Earthquake magnitude M_w : 7.00	Unit weight calculation: Based on SBT	Clay like behavior applied: Sands only
Peak ground acceleration: 0.62	Use fill: No	Limit depth applied: No
Depth to water table (insitu): 5.00 ft	Fill height: N/A	Limit depth: N/A

SBT legend

1. Sensitive fine grained	4. Clayey silt to silty	7. Gravely sand to sand
2. Organic material	5. Silty sand to sandy silt	8. Very stiff sand to
3. Clay to silty clay	6. Clean sand to silty sand	9. Very stiff fine grained

Estimation of post-earthquake settlements

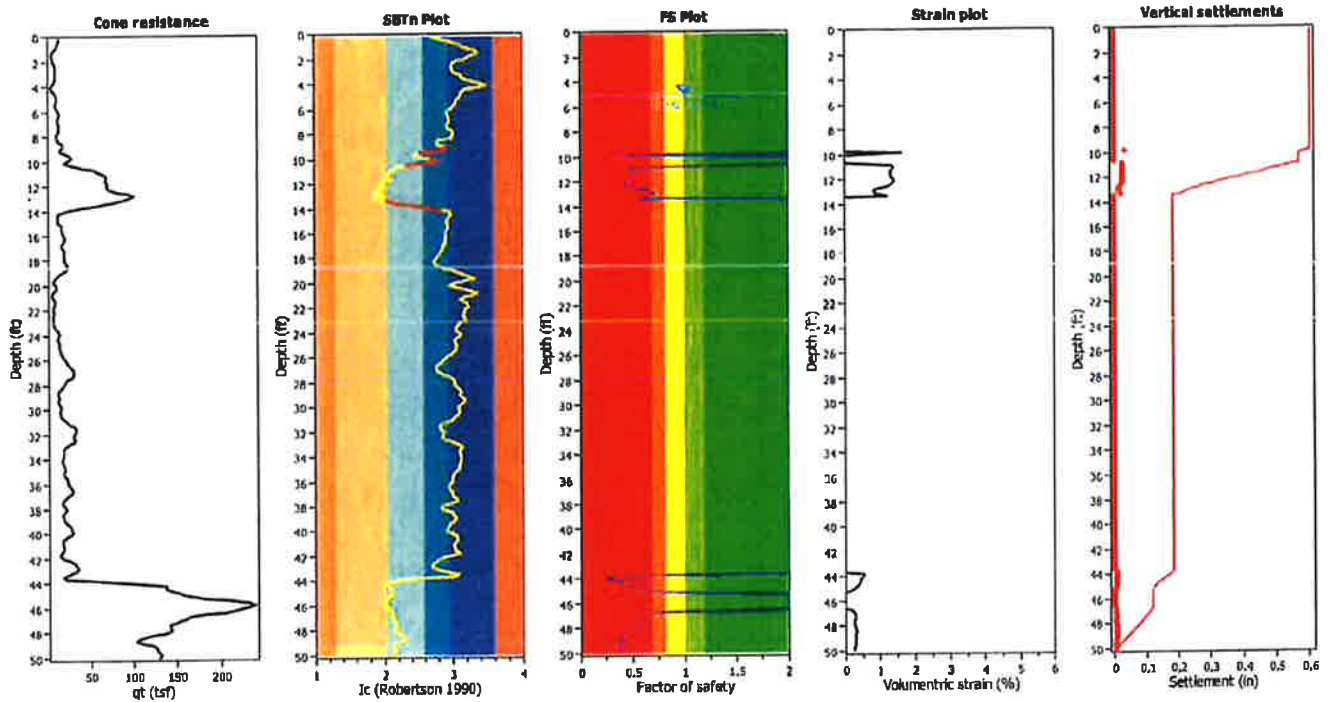

Abbreviations

- q_t : Total cone resistance (cone resistance q_c corrected for pore water effects)
- I_c : Soil Behaviour Type Index
- FS: Calculated Factor of Safety against liquefaction
- Volumetric strain: Post-liquefaction volumetric strain

:: Post-earthquake settlement due to soil liquefaction ::

Depth (ft)	Q _{br,cs}	FS	e _v (%)	DF	Settlement (in)	Depth (ft)	Q _{br,cs}	FS	e _v (%)	DF	Settlement (in)
5.09	127.37	2.00	0.00	0.91	0.00	5.25	119.49	2.00	0.00	0.91	0.00
5.41	113.35	2.00	0.00	0.91	0.00	5.58	113.16	2.00	0.00	0.91	0.00
5.74	117.65	2.00	0.00	0.90	0.00	5.91	125.63	2.00	0.00	0.90	0.00
6.07	130.75	2.00	0.00	0.90	0.00	6.23	132.49	2.00	0.00	0.89	0.00
6.40	127.60	2.00	0.00	0.89	0.00	6.56	121.22	2.00	0.00	0.89	0.00
6.73	117.19	2.00	0.00	0.89	0.00	6.89	120.21	2.00	0.00	0.88	0.00
7.05	126.68	2.00	0.00	0.88	0.00	7.22	131.34	2.00	0.00	0.88	0.00
7.38	131.78	2.00	0.00	0.87	0.00	7.55	126.79	2.00	0.00	0.87	0.00
7.71	121.06	2.00	0.00	0.87	0.00	7.87	117.19	2.00	0.00	0.87	0.00
8.04	117.12	2.00	0.00	0.86	0.00	8.20	119.47	2.00	0.00	0.86	0.00
8.37	119.27	2.00	0.00	0.86	0.00	8.53	121.32	2.00	0.00	0.86	0.00
8.69	124.70	2.00	0.00	0.85	0.00	8.86	128.95	2.00	0.00	0.85	0.00
9.02	129.12	2.00	0.00	0.85	0.00	9.19	127.47	2.00	0.00	0.84	0.00
9.35	122.72	2.00	0.00	0.84	0.00	9.51	116.46	2.00	0.00	0.84	0.00
9.68	114.65	2.00	0.00	0.84	0.00	9.84	120.86	0.31	1.67	0.83	0.03
10.01	131.87	2.00	0.00	0.83	0.00	10.17	136.75	2.00	0.00	0.83	0.00
10.33	129.18	2.00	0.00	0.82	0.00	10.50	131.40	2.00	0.00	0.82	0.00
10.66	138.30	2.00	0.00	0.82	0.00	10.83	146.41	0.46	1.40	0.82	0.03
10.99	147.57	0.47	1.38	0.81	0.03	11.15	150.18	0.48	1.36	0.81	0.03
11.32	153.14	0.51	1.33	0.81	0.03	11.48	154.18	0.51	1.32	0.81	0.03
11.65	154.59	0.51	1.31	0.80	0.03	11.81	149.59	0.47	1.34	0.80	0.03
11.98	140.81	0.41	1.41	0.80	0.03	12.14	138.61	0.39	1.42	0.79	0.03
12.30	145.58	0.44	1.36	0.79	0.03	12.47	157.53	0.53	1.27	0.79	0.02
12.63	168.60	0.62	1.12	0.79	0.02	12.80	177.45	0.71	0.85	0.78	0.02
12.96	179.03	0.72	0.84	0.78	0.02	13.12	172.48	0.65	0.88	0.78	0.02
13.29	159.22	0.53	1.24	0.77	0.02	13.45	146.27	2.00	0.00	0.77	0.00
13.62	141.78	2.00	0.00	0.77	0.00	13.78	142.06	2.00	0.00	0.77	0.00
13.94	145.72	2.00	0.00	0.76	0.00	14.11	132.98	2.00	0.00	0.76	0.00
14.27	119.03	2.00	0.00	0.76	0.00	14.44	112.71	2.00	0.00	0.76	0.00
14.60	111.46	2.00	0.00	0.75	0.00	14.76	108.38	2.00	0.00	0.75	0.00
14.93	116.35	2.00	0.00	0.75	0.00	15.09	130.00	2.00	0.00	0.74	0.00
15.26	149.07	2.00	0.00	0.74	0.00	15.42	157.25	2.00	0.00	0.74	0.00
15.58	159.45	2.00	0.00	0.74	0.00	15.75	158.88	2.00	0.00	0.73	0.00
15.91	165.53	2.00	0.00	0.73	0.00	16.08	175.02	2.00	0.00	0.73	0.00
16.24	178.82	2.00	0.00	0.72	0.00	16.40	169.21	2.00	0.00	0.72	0.00
16.57	151.67	2.00	0.00	0.72	0.00	16.73	141.35	2.00	0.00	0.72	0.00
16.90	144.74	2.00	0.00	0.71	0.00	17.06	155.54	2.00	0.00	0.71	0.00
17.22	158.56	2.00	0.00	0.71	0.00	17.39	153.65	2.00	0.00	0.71	0.00
17.55	144.32	2.00	0.00	0.70	0.00	17.72	137.10	2.00	0.00	0.70	0.00
17.88	133.41	2.00	0.00	0.70	0.00	18.04	132.27	2.00	0.00	0.69	0.00
18.21	132.81	2.00	0.00	0.69	0.00	18.37	139.88	2.00	0.00	0.69	0.00
18.54	148.48	2.00	0.00	0.69	0.00	18.70	155.60	2.00	0.00	0.68	0.00
18.86	156.96	2.00	0.00	0.68	0.00	19.03	150.28	2.00	0.00	0.68	0.00
19.19	132.61	2.00	0.00	0.67	0.00	19.36	110.95	2.00	0.00	0.67	0.00
19.52	92.40	2.00	0.00	0.67	0.00	19.69	85.03	2.00	0.00	0.67	0.00
19.85	87.20	2.00	0.00	0.66	0.00	20.01	90.64	2.00	0.00	0.66	0.00
20.18	86.64	2.00	0.00	0.66	0.00	20.34	77.11	2.00	0.00	0.66	0.00
20.51	64.27	2.00	0.00	0.65	0.00	20.67	60.49	2.00	0.00	0.65	0.00

:: Post-earthquake settlement due to soil liquefaction :: (continued)

Depth (ft)	Q _{m,cs}	FS	e _v (%)	DF	Settlement (in)	Depth (ft)	Q _{m,cs}	FS	e _v (%)	DF	Settlement (in)
20.83	63.43	2.00	0.00	0.65	0.00	21.00	73.99	2.00	0.00	0.64	0.00
21.16	83.74	2.00	0.00	0.64	0.00	21.33	87.98	2.00	0.00	0.64	0.00
21.49	84.64	2.00	0.00	0.64	0.00	21.65	79.41	2.00	0.00	0.63	0.00
21.82	75.84	2.00	0.00	0.63	0.00	21.98	75.52	2.00	0.00	0.63	0.00
22.15	72.96	2.00	0.00	0.62	0.00	22.31	70.01	2.00	0.00	0.62	0.00
22.47	67.39	2.00	0.00	0.62	0.00	22.64	66.02	2.00	0.00	0.62	0.00
22.80	63.43	2.00	0.00	0.61	0.00	22.97	61.31	2.00	0.00	0.61	0.00
23.13	62.43	2.00	0.00	0.61	0.00	23.29	67.42	2.00	0.00	0.61	0.00
23.46	79.39	2.00	0.00	0.60	0.00	23.62	96.34	2.00	0.00	0.60	0.00
23.79	115.78	2.00	0.00	0.60	0.00	23.95	124.36	2.00	0.00	0.59	0.00
24.11	117.81	2.00	0.00	0.59	0.00	24.28	103.27	2.00	0.00	0.59	0.00
24.44	98.49	2.00	0.00	0.59	0.00	24.61	107.32	2.00	0.00	0.58	0.00
24.77	116.03	2.00	0.00	0.58	0.00	24.93	117.41	2.00	0.00	0.58	0.00
25.10	118.11	2.00	0.00	0.57	0.00	25.26	121.63	2.00	0.00	0.57	0.00
25.43	127.56	2.00	0.00	0.57	0.00	25.59	131.21	2.00	0.00	0.57	0.00
25.75	134.30	2.00	0.00	0.56	0.00	25.92	135.35	2.00	0.00	0.56	0.00
26.08	138.32	2.00	0.00	0.56	0.00	26.25	139.70	2.00	0.00	0.56	0.00
26.41	142.59	2.00	0.00	0.55	0.00	26.57	143.52	2.00	0.00	0.55	0.00
26.74	146.30	2.00	0.00	0.55	0.00	26.90	148.78	2.00	0.00	0.54	0.00
27.07	153.24	2.00	0.00	0.54	0.00	27.23	157.13	2.00	0.00	0.54	0.00
27.40	161.54	2.00	0.00	0.54	0.00	27.56	159.33	2.00	0.00	0.53	0.00
27.72	152.14	2.00	0.00	0.53	0.00	27.89	143.29	2.00	0.00	0.53	0.00
28.05	134.80	2.00	0.00	0.52	0.00	28.22	124.27	2.00	0.00	0.52	0.00
28.38	108.25	2.00	0.00	0.52	0.00	28.54	96.08	2.00	0.00	0.52	0.00
28.71	92.35	2.00	0.00	0.51	0.00	28.87	97.40	2.00	0.00	0.51	0.00
29.04	101.07	2.00	0.00	0.51	0.00	29.20	100.91	2.00	0.00	0.51	0.00
29.36	102.76	2.00	0.00	0.50	0.00	29.53	111.04	2.00	0.00	0.50	0.00
29.69	118.27	2.00	0.00	0.50	0.00	29.86	116.65	2.00	0.00	0.49	0.00
30.02	108.68	2.00	0.00	0.49	0.00	30.18	104.42	2.00	0.00	0.49	0.00
30.35	106.70	2.00	0.00	0.49	0.00	30.51	110.90	2.00	0.00	0.48	0.00
30.68	119.28	2.00	0.00	0.48	0.00	30.84	131.25	2.00	0.00	0.48	0.00
31.00	143.34	2.00	0.00	0.47	0.00	31.17	149.71	2.00	0.00	0.47	0.00
31.33	153.20	2.00	0.00	0.47	0.00	31.50	154.93	2.00	0.00	0.47	0.00
31.66	154.98	2.00	0.00	0.46	0.00	31.82	152.65	2.00	0.00	0.46	0.00
31.99	150.91	2.00	0.00	0.46	0.00	32.15	151.61	2.00	0.00	0.46	0.00
32.32	152.30	2.00	0.00	0.45	0.00	32.48	150.02	2.00	0.00	0.45	0.00
32.64	148.28	2.00	0.00	0.45	0.00	32.81	146.08	2.00	0.00	0.44	0.00
32.97	140.50	2.00	0.00	0.44	0.00	33.14	132.83	2.00	0.00	0.44	0.00
33.30	127.45	2.00	0.00	0.44	0.00	33.46	126.48	2.00	0.00	0.43	0.00
33.63	124.59	2.00	0.00	0.43	0.00	33.79	119.28	2.00	0.00	0.43	0.00
33.96	113.00	2.00	0.00	0.42	0.00	34.12	109.48	2.00	0.00	0.42	0.00
34.28	116.14	2.00	0.00	0.42	0.00	34.45	126.76	2.00	0.00	0.42	0.00
34.61	135.08	2.00	0.00	0.41	0.00	34.78	132.53	2.00	0.00	0.41	0.00
34.94	124.15	2.00	0.00	0.41	0.00	35.10	114.35	2.00	0.00	0.41	0.00
35.27	111.88	2.00	0.00	0.40	0.00	35.43	117.66	2.00	0.00	0.40	0.00
35.60	125.53	2.00	0.00	0.40	0.00	35.76	129.07	2.00	0.00	0.39	0.00
35.93	127.95	2.00	0.00	0.39	0.00	36.09	130.03	2.00	0.00	0.39	0.00
36.25	136.67	2.00	0.00	0.39	0.00	36.42	143.56	2.00	0.00	0.38	0.00

:: Post-earthquake settlement due to soil liquefaction :: (continued)

Depth (ft)	$Q_{n,cs}$	FS	e_v (%)	DF	Settlement (in)	Depth (ft)	$Q_{n,cs}$	FS	e_v (%)	DF	Settlement (in)
36.58	145.69	2.00	0.00	0.38	0.00	36.75	140.48	2.00	0.00	0.38	0.00
36.91	129.95	2.00	0.00	0.37	0.00	37.07	115.10	2.00	0.00	0.37	0.00
37.24	100.54	2.00	0.00	0.37	0.00	37.40	92.13	2.00	0.00	0.37	0.00
37.57	92.78	2.00	0.00	0.36	0.00	37.73	95.73	2.00	0.00	0.36	0.00
37.89	91.39	2.00	0.00	0.36	0.00	38.06	83.17	2.00	0.00	0.35	0.00
38.22	76.62	2.00	0.00	0.35	0.00	38.39	81.95	2.00	0.00	0.35	0.00
38.55	83.71	2.00	0.00	0.35	0.00	38.71	95.04	2.00	0.00	0.34	0.00
38.88	102.72	2.00	0.00	0.34	0.00	39.04	113.82	2.00	0.00	0.34	0.00
39.21	118.10	2.00	0.00	0.34	0.00	39.37	121.30	2.00	0.00	0.33	0.00
39.53	123.58	2.00	0.00	0.33	0.00	39.70	124.11	2.00	0.00	0.33	0.00
39.86	123.07	2.00	0.00	0.32	0.00	40.03	118.57	2.00	0.00	0.32	0.00
40.19	108.85	2.00	0.00	0.32	0.00	40.35	97.01	2.00	0.00	0.32	0.00
40.52	88.01	2.00	0.00	0.31	0.00	40.68	85.84	2.00	0.00	0.31	0.00
40.85	86.82	2.00	0.00	0.31	0.00	41.01	89.30	2.00	0.00	0.30	0.00
41.17	89.42	2.00	0.00	0.30	0.00	41.34	84.47	2.00	0.00	0.30	0.00
41.50	73.63	2.00	0.00	0.30	0.00	41.67	65.06	2.00	0.00	0.29	0.00
41.83	67.42	2.00	0.00	0.29	0.00	41.99	80.95	2.00	0.00	0.29	0.00
42.16	93.62	2.00	0.00	0.29	0.00	42.32	99.43	2.00	0.00	0.28	0.00
42.49	100.79	2.00	0.00	0.28	0.00	42.65	100.87	2.00	0.00	0.28	0.00
42.81	99.41	2.00	0.00	0.27	0.00	42.98	96.23	2.00	0.00	0.27	0.00
43.14	91.25	2.00	0.00	0.27	0.00	43.31	86.33	2.00	0.00	0.27	0.00
43.47	88.81	2.00	0.00	0.26	0.00	43.64	102.90	2.00	0.00	0.26	0.00
43.80	113.90	0.23	0.54	0.26	0.01	43.96	122.97	0.27	0.50	0.25	0.01
44.13	139.26	0.35	0.45	0.25	0.01	44.29	148.43	0.40	0.42	0.25	0.01
44.46	152.43	0.43	0.41	0.25	0.01	44.62	159.89	0.48	0.39	0.24	0.01
44.78	171.85	0.58	0.33	0.24	0.01	44.95	182.95	0.69	0.25	0.24	0.00
45.11	192.06	0.78	0.18	0.24	0.00	45.28	201.91	2.00	0.00	0.23	0.00
45.44	220.10	2.00	0.00	0.23	0.00	45.60	240.58	2.00	0.00	0.23	0.00
45.77	249.06	2.00	0.00	0.22	0.00	45.93	243.53	2.00	0.00	0.22	0.00
46.10	234.95	2.00	0.00	0.22	0.00	46.26	230.52	2.00	0.00	0.22	0.00
46.42	221.36	2.00	0.00	0.21	0.00	46.59	204.10	2.00	0.00	0.21	0.00
46.75	186.02	0.73	0.21	0.21	0.00	46.92	177.02	0.64	0.27	0.20	0.01
47.08	172.98	0.60	0.28	0.20	0.01	47.24	168.58	0.56	0.28	0.20	0.01
47.41	166.35	0.55	0.30	0.20	0.01	47.57	169.50	0.57	0.27	0.19	0.01
47.74	169.35	0.57	0.27	0.19	0.01	47.90	166.79	0.55	0.27	0.19	0.01
48.06	154.71	0.46	0.30	0.19	0.01	48.23	147.84	0.41	0.31	0.18	0.01
48.39	141.89	0.37	0.32	0.18	0.01	48.56	142.08	0.38	0.31	0.18	0.01
48.72	144.70	0.39	0.30	0.17	0.01	48.88	141.05	0.37	0.30	0.17	0.01
49.05	137.58	0.35	0.30	0.17	0.01	49.21	134.76	0.34	0.30	0.17	0.01
49.38	138.58	0.36	0.29	0.16	0.01	49.54	141.63	0.38	0.28	0.16	0.01
49.70	144.86	0.40	0.27	0.16	0.01	49.87	143.09	0.39	0.27	0.15	0.01
50.03	141.81	0.38	0.27	0.15	0.01						

Total estimated settlement: 0.61**Abbreviations**

$Q_{n,cs}$:	Equivalent clean sand normalized cone resistance
FS:	Factor of safety against liquefaction
e_v (%):	Post-liquefaction volumetric strain
DF:	e_v depth weighting factor
Settlement:	Calculated settlement

LIQUEFACTION ANALYSIS REPORT

Project title : JR Simplot Fertilizer Facility

Location : Brawley, CA

CPT file : CPT-3

Input parameters and analysis data

Analysis method:	NCEER (1998)	G.W.T. (In-situ):	5.00 ft	Use fill:	No	Clay like behavior	
Fines correction method:	NCEER (1998)	G.W.T. (earthq.):	5.00 ft	Fill height:	N/A	applied:	Sands only
Points to test:	Based on Ic value	Average results interval:	3	Fill weight:	N/A	Limit depth applied:	No
Earthquake magnitude M_w :	7.00	Ic cut-off value:	2.60	Trans. detect. applied:	Yes	Limit depth:	N/A
Peak ground acceleration:	0.82	Unit weight calculation:	Based on SBT	K_f applied:	Yes	MSF method:	Method based

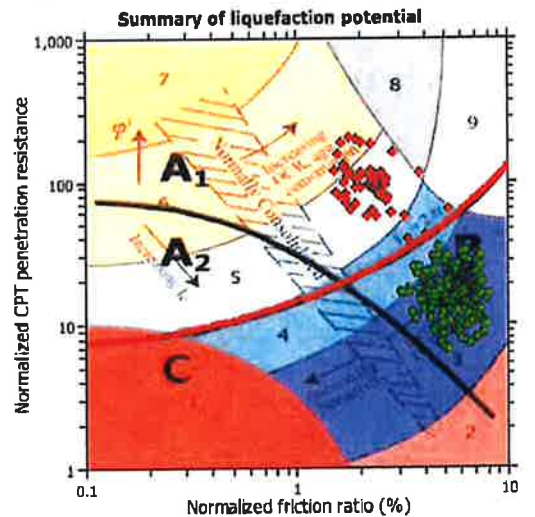
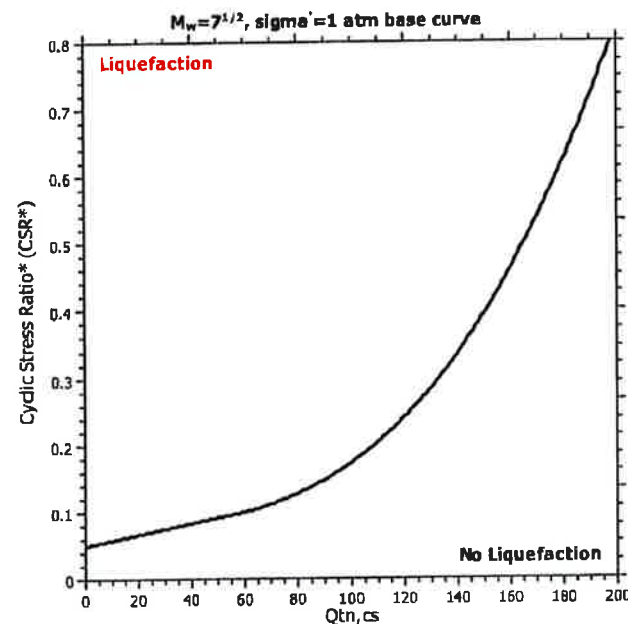
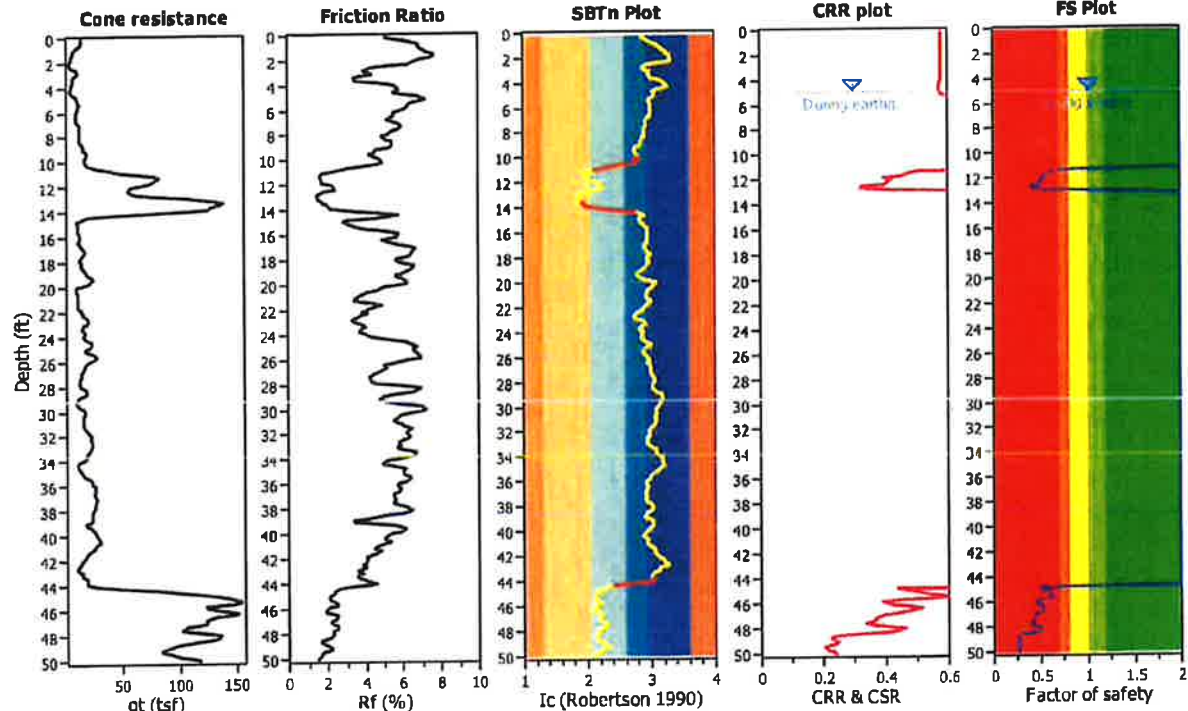

Zone A1: Cyclic liquefaction likely depending on size and duration of cyclic loading
 Zone A2: Cyclic liquefaction and strength loss likely depending on loading and ground geometry
 Zone B: Liquefaction and post-earthquake strength loss unlikely, check cyclic softening
 Zone C: Cyclic liquefaction and strength loss possible depending on soil plasticity, brittleness/sensitivity, strain to peak undrained strength and ground geometry

CPT basic interpretation plots

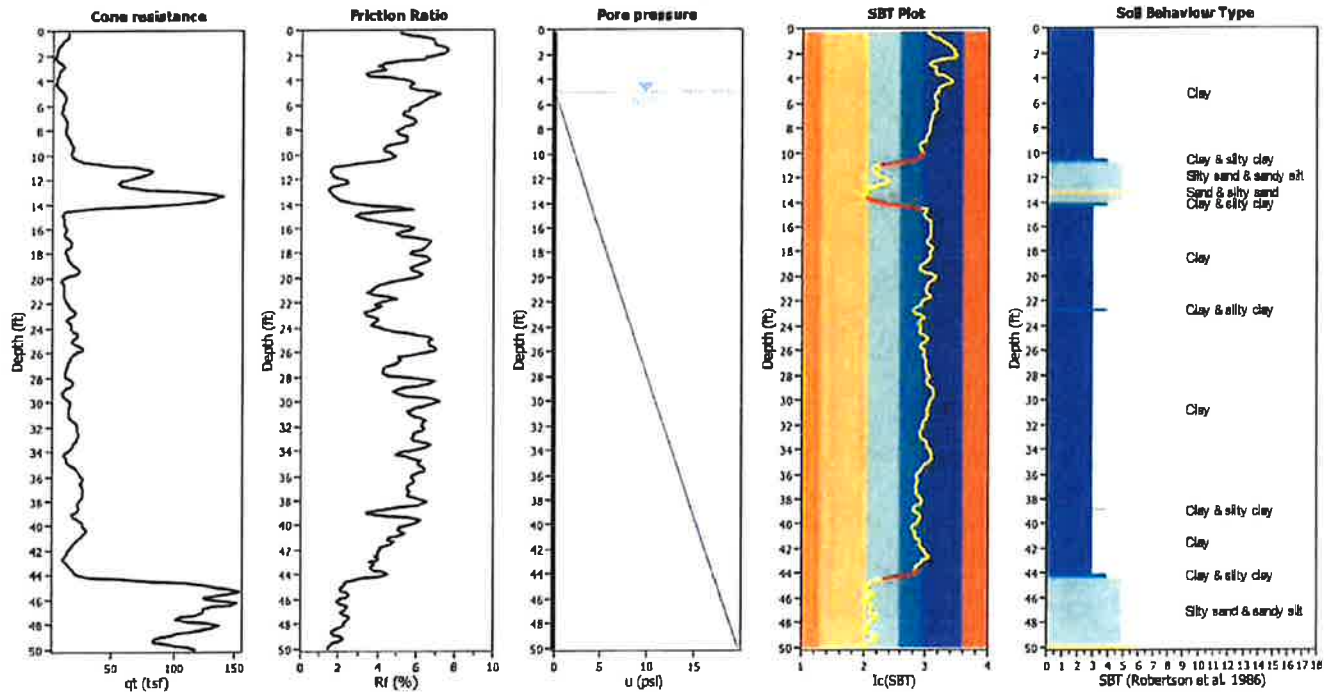

Input parameters and analysis data

Analysis method:	NCEER (1998)	Depth to water table (earthq.):	5.00 ft	Fill weight:	N/A
Fines correction method:	NCEER (1998)	Average results interval:	3	Transition detect. applied:	Yes
Points to test:	Based on Ic value	Ic cut-off value:	2.60	K_f applied:	Yes
Earthquake magnitude M_w :	7.00	Unit weight calculation:	Based on SBT	Clay log behavior applied:	Sends only
Peak ground acceleration:	0.82	Use fill:	No	Limit depth applied:	No
Depth to water table (mslu):	5.00 ft	Fill height:	N/A	Limit depth:	N/A

SBT legend

- | | | |
|---------------------------|-----------------------------|----------------------------|
| 1. Sensitive fine grained | 4. Clayey silt to silty | 7. Gravely sand to sand |
| 2. Organic material | 5. Silty sand to sandy silt | 8. Very stiff sand to |
| 3. Clay to silty clay | 6. Clean sand to silty sand | 9. Very stiff fine grained |

Estimation of post-earthquake settlements

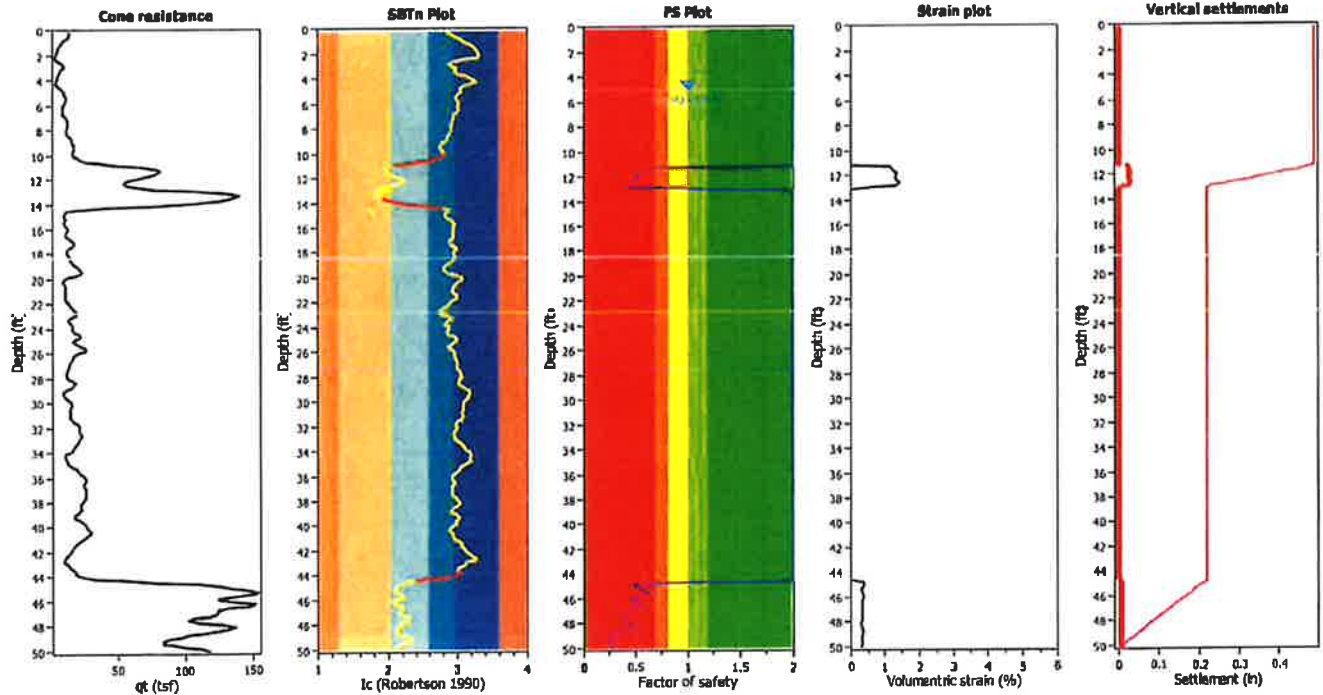

Abbreviations

- q_t : Total cone resistance (cone resistance q_c corrected for pore water effects)
- I_c : Soil Behaviour Type Index
- FS: Calculated Factor of Safety against liquefaction
- Volumetric strain: Post-liquefaction volumetric strain

:: Post-earthquake settlement due to soil liquefaction ::

Depth (ft)	Q _{u,c}	FS	e _v (%)	DF	Settlement (in)	Depth (ft)	Q _{u,c}	FS	e _v (%)	DF	Settlement (in)
5.09	131.35	2.00	0.00	0.91	0.00	5.25	133.76	2.00	0.00	0.91	0.00
5.41	132.28	2.00	0.00	0.91	0.00	5.58	128.20	2.00	0.00	0.91	0.00
5.74	123.44	2.00	0.00	0.90	0.00	5.91	117.36	2.00	0.00	0.90	0.00
6.07	113.96	2.00	0.00	0.90	0.00	6.23	111.56	2.00	0.00	0.89	0.00
6.40	109.50	2.00	0.00	0.89	0.00	6.56	106.03	2.00	0.00	0.89	0.00
6.73	107.64	2.00	0.00	0.89	0.00	6.89	116.11	2.00	0.00	0.88	0.00
7.05	125.45	2.00	0.00	0.88	0.00	7.22	129.47	2.00	0.00	0.88	0.00
7.38	129.08	2.00	0.00	0.87	0.00	7.55	127.21	2.00	0.00	0.87	0.00
7.71	124.34	2.00	0.00	0.87	0.00	7.87	119.29	2.00	0.00	0.87	0.00
8.04	113.97	2.00	0.00	0.86	0.00	8.20	114.89	2.00	0.00	0.86	0.00
8.37	120.82	2.00	0.00	0.86	0.00	8.53	129.21	2.00	0.00	0.86	0.00
8.69	134.17	2.00	0.00	0.85	0.00	8.86	135.30	2.00	0.00	0.85	0.00
9.02	133.22	2.00	0.00	0.85	0.00	9.19	128.74	2.00	0.00	0.84	0.00
9.35	127.40	2.00	0.00	0.84	0.00	9.51	124.25	2.00	0.00	0.84	0.00
9.68	124.15	2.00	0.00	0.84	0.00	9.84	126.27	2.00	0.00	0.83	0.00
10.01	131.05	2.00	0.00	0.83	0.00	10.17	136.37	2.00	0.00	0.83	0.00
10.33	139.45	2.00	0.00	0.82	0.00	10.50	139.51	2.00	0.00	0.82	0.00
10.66	139.39	2.00	0.00	0.82	0.00	10.83	141.51	2.00	0.00	0.82	0.00
10.99	150.55	2.00	0.00	0.81	0.00	11.15	160.46	2.00	0.00	0.81	0.00
11.32	166.52	0.62	1.17	0.81	0.02	11.48	162.52	0.58	1.21	0.81	0.02
11.65	158.55	0.55	1.29	0.80	0.03	11.81	150.29	0.48	1.34	0.80	0.03
11.98	154.59	0.51	1.30	0.80	0.03	12.14	152.97	0.49	1.31	0.79	0.03
12.30	150.73	0.47	1.32	0.79	0.03	12.47	138.02	0.39	1.41	0.79	0.03
12.63	137.56	0.38	1.41	0.79	0.03	12.80	151.20	0.47	1.30	0.78	0.03
12.96	185.15	0.79	0.65	0.78	0.01	13.12	217.87	2.00	0.00	0.78	0.00
13.29	237.00	2.00	0.00	0.77	0.00	13.45	236.80	2.00	0.00	0.77	0.00
13.62	232.68	2.00	0.00	0.77	0.00	13.78	233.32	2.00	0.00	0.77	0.00
13.94	229.89	2.00	0.00	0.76	0.00	14.11	218.83	2.00	0.00	0.76	0.00
14.27	194.89	2.00	0.00	0.76	0.00	14.44	155.33	2.00	0.00	0.76	0.00
14.60	110.46	2.00	0.00	0.75	0.00	14.76	86.67	2.00	0.00	0.75	0.00
14.93	83.75	2.00	0.00	0.75	0.00	15.09	88.49	2.00	0.00	0.74	0.00
15.26	93.29	2.00	0.00	0.74	0.00	15.42	96.52	2.00	0.00	0.74	0.00
15.58	106.56	2.00	0.00	0.74	0.00	15.75	119.29	2.00	0.00	0.73	0.00
15.91	128.71	2.00	0.00	0.73	0.00	16.08	127.73	2.00	0.00	0.73	0.00
16.24	119.11	2.00	0.00	0.72	0.00	16.40	112.08	2.00	0.00	0.72	0.00
16.57	116.46	2.00	0.00	0.72	0.00	16.73	132.09	2.00	0.00	0.72	0.00
16.90	148.86	2.00	0.00	0.71	0.00	17.06	158.25	2.00	0.00	0.71	0.00
17.22	156.88	2.00	0.00	0.71	0.00	17.39	149.31	2.00	0.00	0.71	0.00
17.55	138.49	2.00	0.00	0.70	0.00	17.72	129.85	2.00	0.00	0.70	0.00
17.88	125.00	2.00	0.00	0.70	0.00	18.04	126.82	2.00	0.00	0.69	0.00
18.21	133.95	2.00	0.00	0.69	0.00	18.37	141.49	2.00	0.00	0.69	0.00
18.54	145.26	2.00	0.00	0.69	0.00	18.70	147.97	2.00	0.00	0.68	0.00
18.86	148.21	2.00	0.00	0.68	0.00	19.03	151.27	2.00	0.00	0.68	0.00
19.19	152.81	2.00	0.00	0.67	0.00	19.36	158.48	2.00	0.00	0.67	0.00
19.52	159.96	2.00	0.00	0.67	0.00	19.69	151.92	2.00	0.00	0.67	0.00
19.85	131.30	2.00	0.00	0.66	0.00	20.01	110.03	2.00	0.00	0.66	0.00
20.18	99.30	2.00	0.00	0.66	0.00	20.34	98.95	2.00	0.00	0.66	0.00
20.51	96.83	2.00	0.00	0.65	0.00	20.67	94.65	2.00	0.00	0.65	0.00

:: Post-earthquake settlement due to soil liquefaction :: (continued)

Depth (ft)	Q _{u,cs}	FS	e _v (%)	DF	Settlement (in)	Depth (ft)	Q _{u,cs}	FS	e _v (%)	DF	Settlement (in)
20.83	92.07	2.00	0.00	0.65	0.00	21.00	89.89	2.00	0.00	0.64	0.00
21.16	87.58	2.00	0.00	0.64	0.00	21.33	91.87	2.00	0.00	0.64	0.00
21.49	98.63	2.00	0.00	0.64	0.00	21.65	106.06	2.00	0.00	0.63	0.00
21.82	103.44	2.00	0.00	0.63	0.00	21.98	102.87	2.00	0.00	0.63	0.00
22.15	101.49	2.00	0.00	0.62	0.00	22.31	108.26	2.00	0.00	0.62	0.00
22.47	108.79	2.00	0.00	0.62	0.00	22.64	107.98	2.00	0.00	0.62	0.00
22.80	104.56	2.00	0.00	0.61	0.00	22.97	101.60	2.00	0.00	0.61	0.00
23.13	99.39	2.00	0.00	0.61	0.00	23.29	99.59	2.00	0.00	0.61	0.00
23.46	101.37	2.00	0.00	0.60	0.00	23.62	102.70	2.00	0.00	0.60	0.00
23.79	102.26	2.00	0.00	0.60	0.00	23.95	103.11	2.00	0.00	0.59	0.00
24.11	110.14	2.00	0.00	0.59	0.00	24.28	123.50	2.00	0.00	0.59	0.00
24.44	138.46	2.00	0.00	0.59	0.00	24.61	149.10	2.00	0.00	0.58	0.00
24.77	148.50	2.00	0.00	0.58	0.00	24.93	140.71	2.00	0.00	0.58	0.00
25.10	136.25	2.00	0.00	0.57	0.00	25.26	144.07	2.00	0.00	0.57	0.00
25.43	157.70	2.00	0.00	0.57	0.00	25.59	168.08	2.00	0.00	0.57	0.00
25.75	167.60	2.00	0.00	0.56	0.00	25.92	156.13	2.00	0.00	0.56	0.00
26.08	136.55	2.00	0.00	0.56	0.00	26.25	121.41	2.00	0.00	0.56	0.00
26.41	114.47	2.00	0.00	0.55	0.00	26.57	114.39	2.00	0.00	0.55	0.00
26.74	111.66	2.00	0.00	0.55	0.00	26.90	106.79	2.00	0.00	0.54	0.00
27.07	101.04	2.00	0.00	0.54	0.00	27.23	97.42	2.00	0.00	0.54	0.00
27.40	94.53	2.00	0.00	0.54	0.00	27.56	92.73	2.00	0.00	0.53	0.00
27.72	91.10	2.00	0.00	0.53	0.00	27.89	94.61	2.00	0.00	0.53	0.00
28.05	109.09	2.00	0.00	0.52	0.00	28.22	127.46	2.00	0.00	0.52	0.00
28.38	137.56	2.00	0.00	0.52	0.00	28.54	133.04	2.00	0.00	0.52	0.00
28.71	118.93	2.00	0.00	0.51	0.00	28.87	103.04	2.00	0.00	0.51	0.00
29.04	90.64	2.00	0.00	0.51	0.00	29.20	85.43	2.00	0.00	0.51	0.00
29.36	88.66	2.00	0.00	0.50	0.00	29.53	97.26	2.00	0.00	0.50	0.00
29.69	110.79	2.00	0.00	0.50	0.00	29.86	123.20	2.00	0.00	0.49	0.00
30.02	128.67	2.00	0.00	0.49	0.00	30.18	124.40	2.00	0.00	0.49	0.00
30.35	117.47	2.00	0.00	0.49	0.00	30.51	112.46	2.00	0.00	0.48	0.00
30.68	109.70	2.00	0.00	0.48	0.00	30.84	108.13	2.00	0.00	0.48	0.00
31.00	109.27	2.00	0.00	0.47	0.00	31.17	111.68	2.00	0.00	0.47	0.00
31.33	117.65	2.00	0.00	0.47	0.00	31.50	124.83	2.00	0.00	0.47	0.00
31.66	130.74	2.00	0.00	0.46	0.00	31.82	133.45	2.00	0.00	0.46	0.00
31.99	134.54	2.00	0.00	0.46	0.00	32.15	135.32	2.00	0.00	0.46	0.00
32.32	134.22	2.00	0.00	0.45	0.00	32.48	132.50	2.00	0.00	0.45	0.00
32.64	130.78	2.00	0.00	0.45	0.00	32.81	129.82	2.00	0.00	0.44	0.00
32.97	126.79	2.00	0.00	0.44	0.00	33.14	125.14	2.00	0.00	0.44	0.00
33.30	125.28	2.00	0.00	0.44	0.00	33.46	126.51	2.00	0.00	0.43	0.00
33.63	123.66	2.00	0.00	0.43	0.00	33.79	114.78	2.00	0.00	0.43	0.00
33.96	101.38	2.00	0.00	0.42	0.00	34.12	90.19	2.00	0.00	0.42	0.00
34.28	86.05	2.00	0.00	0.42	0.00	34.45	91.10	2.00	0.00	0.42	0.00
34.61	96.63	2.00	0.00	0.41	0.00	34.78	100.54	2.00	0.00	0.41	0.00
34.94	103.30	2.00	0.00	0.41	0.00	35.10	110.28	2.00	0.00	0.41	0.00
35.27	119.84	2.00	0.00	0.40	0.00	35.43	127.19	2.00	0.00	0.40	0.00
35.60	129.92	2.00	0.00	0.40	0.00	35.76	130.21	2.00	0.00	0.39	0.00
35.93	130.44	2.00	0.00	0.39	0.00	36.09	132.34	2.00	0.00	0.39	0.00
36.25	132.45	2.00	0.00	0.39	0.00	36.42	130.85	2.00	0.00	0.38	0.00

:: Post-earthquake settlement due to soil liquefaction :: (continued)

Depth (ft)	$Q_{b,cs}$	FS	e_v (%)	DF	Settlement (in)	Depth (ft)	$Q_{b,cs}$	FS	e_v (%)	DF	Settlement (in)
36.58	128.44	2.00	0.00	0.38	0.00	36.75	127.20	2.00	0.00	0.38	0.00
36.91	128.56	2.00	0.00	0.37	0.00	37.07	129.44	2.00	0.00	0.37	0.00
37.24	129.64	2.00	0.00	0.37	0.00	37.40	128.62	2.00	0.00	0.37	0.00
37.57	127.71	2.00	0.00	0.36	0.00	37.73	128.70	2.00	0.00	0.36	0.00
37.89	128.56	2.00	0.00	0.36	0.00	38.06	128.42	2.00	0.00	0.35	0.00
38.22	125.95	2.00	0.00	0.35	0.00	38.39	123.33	2.00	0.00	0.35	0.00
38.55	115.83	2.00	0.00	0.35	0.00	38.71	102.77	2.00	0.00	0.34	0.00
38.88	89.18	2.00	0.00	0.34	0.00	39.04	84.99	2.00	0.00	0.34	0.00
39.21	96.49	2.00	0.00	0.34	0.00	39.37	113.03	2.00	0.00	0.33	0.00
39.53	126.41	2.00	0.00	0.33	0.00	39.70	129.82	2.00	0.00	0.33	0.00
39.86	128.00	2.00	0.00	0.32	0.00	40.03	123.97	2.00	0.00	0.32	0.00
40.19	124.02	2.00	0.00	0.32	0.00	40.35	124.99	2.00	0.00	0.32	0.00
40.52	126.66	2.00	0.00	0.31	0.00	40.68	123.42	2.00	0.00	0.31	0.00
40.85	114.96	2.00	0.00	0.31	0.00	41.01	107.21	2.00	0.00	0.30	0.00
41.17	103.10	2.00	0.00	0.30	0.00	41.34	101.94	2.00	0.00	0.30	0.00
41.50	96.66	2.00	0.00	0.30	0.00	41.67	90.56	2.00	0.00	0.29	0.00
41.83	85.16	2.00	0.00	0.29	0.00	41.99	82.64	2.00	0.00	0.29	0.00
42.16	80.34	2.00	0.00	0.29	0.00	42.32	76.44	2.00	0.00	0.28	0.00
42.49	71.58	2.00	0.00	0.28	0.00	42.65	69.12	2.00	0.00	0.28	0.00
42.81	70.04	2.00	0.00	0.27	0.00	42.98	74.28	2.00	0.00	0.27	0.00
43.14	78.08	2.00	0.00	0.27	0.00	43.31	80.67	2.00	0.00	0.27	0.00
43.47	83.91	2.00	0.00	0.26	0.00	43.64	87.48	2.00	0.00	0.26	0.00
43.80	92.14	2.00	0.00	0.26	0.00	43.96	101.57	2.00	0.00	0.25	0.00
44.13	113.76	2.00	0.00	0.25	0.00	44.29	121.45	2.00	0.00	0.25	0.00
44.46	132.32	2.00	0.00	0.25	0.00	44.62	145.14	2.00	0.00	0.24	0.00
44.78	156.91	0.46	0.39	0.24	0.01	44.95	160.28	0.49	0.38	0.24	0.01
45.11	164.25	0.52	0.37	0.24	0.01	45.28	172.65	0.59	0.32	0.23	0.01
45.44	177.69	0.64	0.30	0.23	0.01	45.60	171.50	0.58	0.32	0.23	0.01
45.77	159.18	0.48	0.36	0.22	0.01	45.93	149.51	0.42	0.37	0.22	0.01
46.10	154.80	0.45	0.36	0.22	0.01	46.26	163.14	0.52	0.34	0.22	0.01
46.42	167.10	0.55	0.33	0.21	0.01	46.59	163.61	0.52	0.33	0.21	0.01
46.75	155.58	0.46	0.34	0.21	0.01	46.92	149.83	0.42	0.34	0.20	0.01
47.08	147.33	0.40	0.34	0.20	0.01	47.24	146.19	0.40	0.34	0.20	0.01
47.41	145.71	0.40	0.34	0.20	0.01	47.57	140.58	0.36	0.34	0.19	0.01
47.74	144.90	0.39	0.33	0.19	0.01	47.90	151.73	0.44	0.31	0.19	0.01
48.06	160.15	0.50	0.29	0.19	0.01	48.23	154.22	0.46	0.30	0.18	0.01
48.39	140.37	0.37	0.32	0.18	0.01	48.56	124.20	0.28	0.35	0.18	0.01
48.72	117.65	0.25	0.36	0.17	0.01	48.88	116.99	0.25	0.35	0.17	0.01
49.05	121.13	0.27	0.34	0.17	0.01	49.21	119.90	0.26	0.33	0.17	0.01
49.38	114.60	0.24	0.34	0.16	0.01	49.54	110.83	0.23	0.34	0.16	0.01
49.70	114.12	0.24	0.33	0.16	0.01	49.87	118.46	0.26	0.31	0.15	0.01
50.03	120.74	0.27	0.30	0.15	0.01						

Total estimated settlement: 0.49

Abbreviations

$Q_{b,cs}$:	Equivalent clean sand normalized cone resistance
FS:	Factor of safety against liquefaction
e_v (%):	Post-liquefaction volumetric strain
DF:	e_v depth weighting factor
Settlement:	Calculated settlement

LIQUEFACTION ANALYSIS REPORT

Project title : JR Simplot Fertilizer Facility

Location : Brawley, CA

CPT file : CPT-4

Input parameters and analysis data

Analysis method:	NCEER (1998)	G.W.T. (in-situ):	5.00 ft	Use fill:	No	Clay like behavior applied:	Sands only
Fines correction method:	NCEER (1998)	G.W.T. (earthq.):	5.00 ft	Fill height:	N/A	Limit depth applied:	No
Points to test:	Based on Ic value	Average results interval:	3	Fill weight:	N/A	Limit depth:	N/A
Earthquake magnitude M_w :	7.00	Ic cut-off value:	2.60	Trans. detect. applied:	Yes	MSF method:	Method based
Peak ground acceleration:	0.82	Unit weight calculation:	Based on SBT	K_s applied:	Yes		

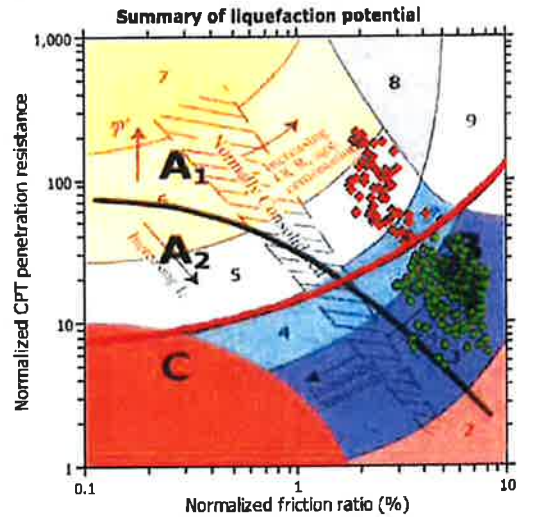
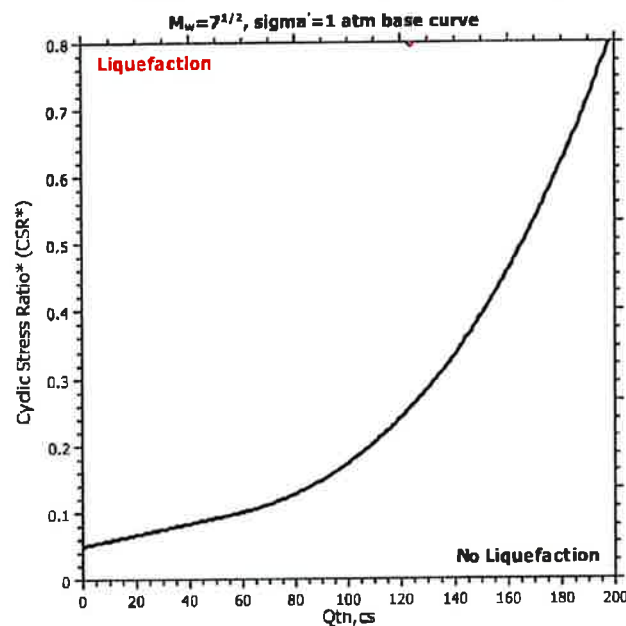
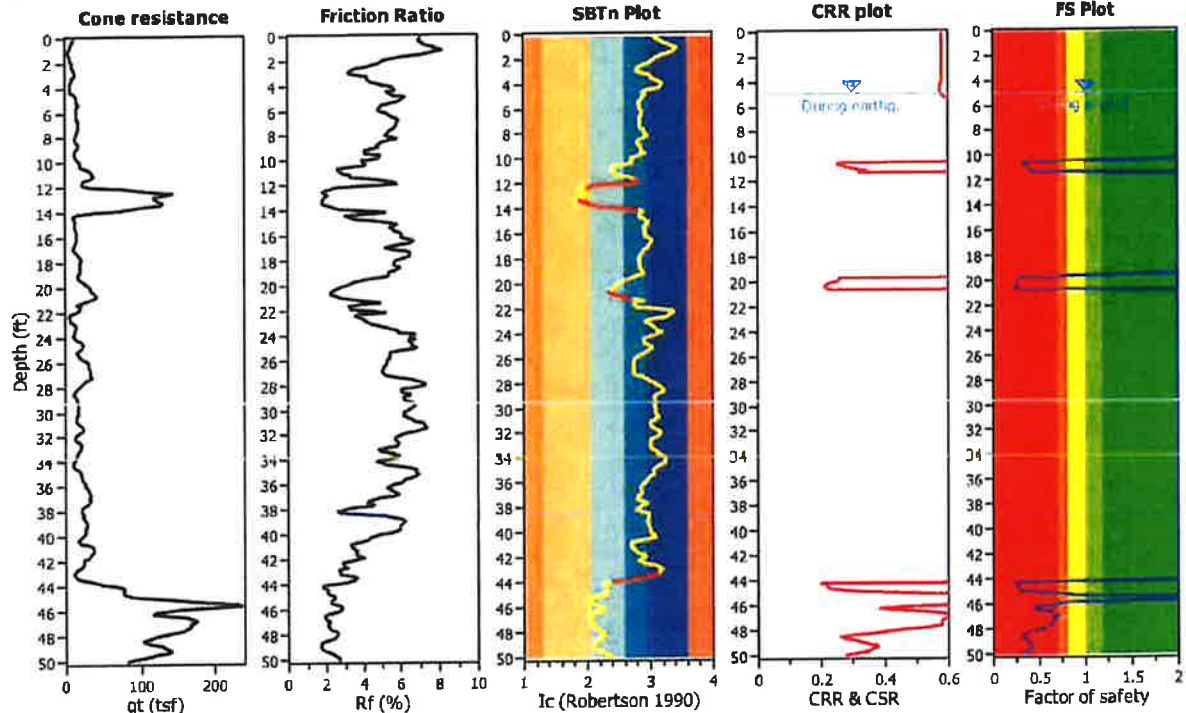

Zone A1: Cyclic liquefaction likely depending on size and duration of cyclic loading
 Zone A2: Cyclic liquefaction and strength loss likely depending on loading and ground geometry
 Zone B: Liquefaction and post-earthquake strength loss unlikely, check cyclic softening
 Zone C: Cyclic liquefaction and strength loss possible depending on soil plasticity, brittleness/sensitivity, strain to peak undrained strength and ground geometry

CPT basic interpretation plots

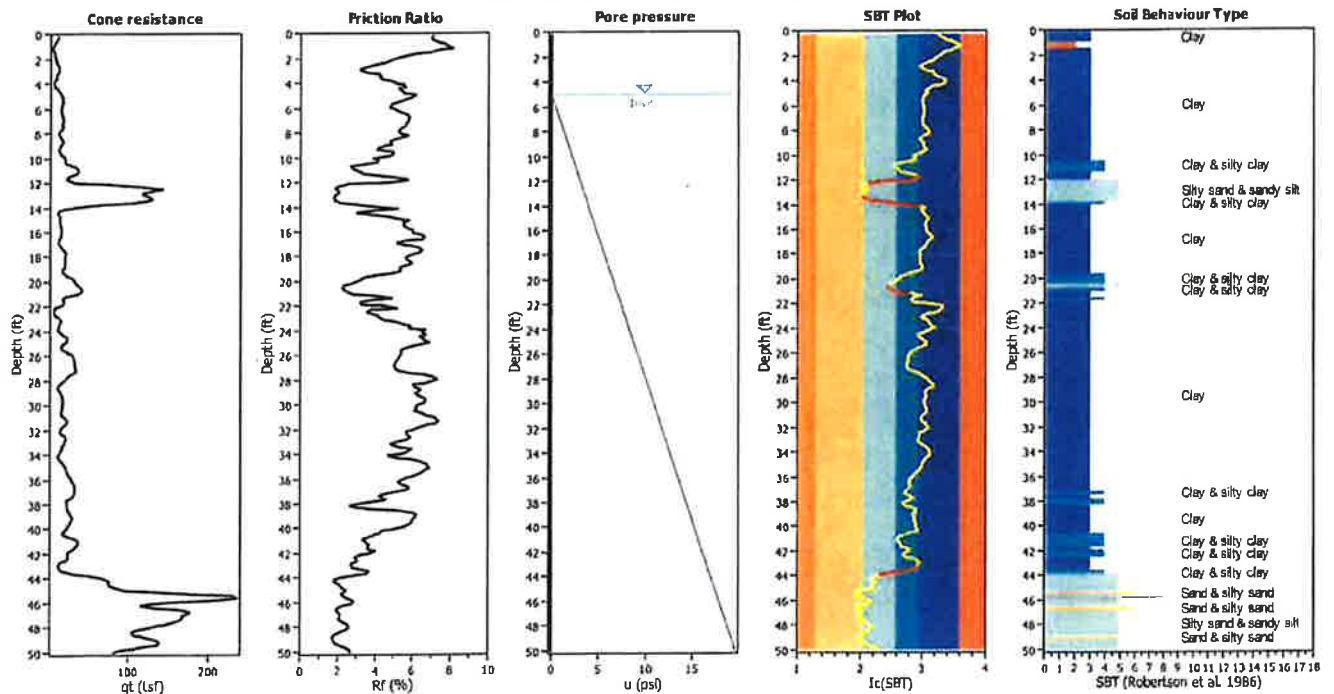

Input parameters and analysis data

Analysis method:	NCEER (1998)	Depth to water table (ortho.):	5.00 ft	Fill weight:	N/A
Fines correction method:	NCFRR (1998)	Average results interval:	3	Transition detect. applied:	Yes
Points to test:	Based on Ic value	Ic cut-off value:	2.60	k_{σ} applied:	Yes
Earthquake magnitude M_w :	7.00	Unit weight calculation:	Based on SBT	Clay like behavior applied:	Sands only
Peak ground acceleration:	0.82	Use fill:	No	Limit depth applied:	No
Depth to water table (instn):	5.00 ft	Fill height:	N/A	Limit depth:	N/A

SBT legend

1. Sensitive fine grained	4. Clayey silt to silty	7. Gravely sand to sand
2. Organic material	5. Silty sand to sandy silt	8. Very stiff sand to
3. Clay to silty clay	6. Clean sand to silty sand	9. Very stiff fine grained

Estimation of post-earthquake settlements

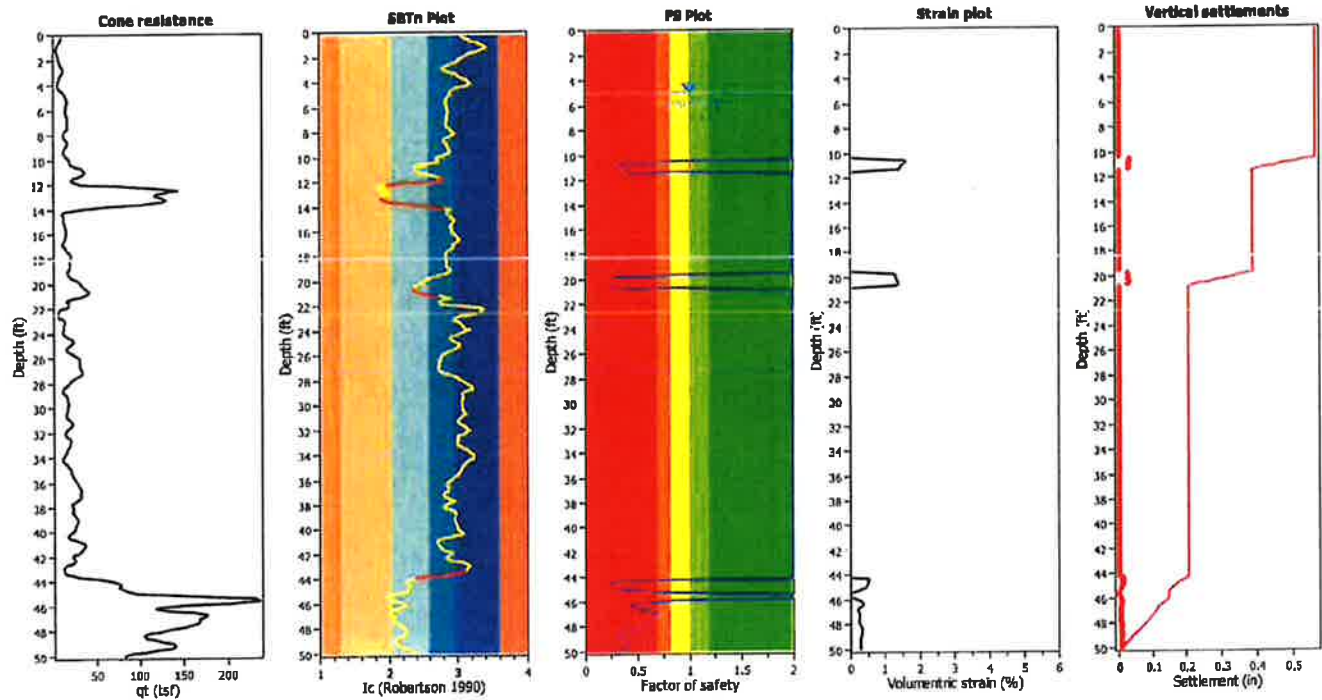

Abbreviations

- q_t : Total cone resistance (cone resistance q_c corrected for pore water effects)
- I_c : Soil Behaviour Type Index
- FS: Calculated Factor of Safety against liquefaction
- Volumetric strain: Post-liquefaction volumetric strain

:: Post-earthquake settlement due to soil liquefaction ::

Depth (ft)	Q _{b,cs}	FS	e _v (%)	DF	Settlement (in)	Depth (ft)	Q _{b,cs}	FS	e _v (%)	DF	Settlement (in)
5.09	139.83	2.00	0.00	0.91	0.00	5.25	138.88	2.00	0.00	0.91	0.00
5.41	134.04	2.00	0.00	0.91	0.00	5.58	127.26	2.00	0.00	0.91	0.00
5.74	122.05	2.00	0.00	0.90	0.00	5.91	120.06	2.00	0.00	0.90	0.00
6.07	122.51	2.00	0.00	0.90	0.00	6.23	127.20	2.00	0.00	0.89	0.00
6.40	133.55	2.00	0.00	0.89	0.00	6.56	139.99	2.00	0.00	0.89	0.00
6.73	143.25	2.00	0.00	0.89	0.00	6.89	143.18	2.00	0.00	0.88	0.00
7.05	141.62	2.00	0.00	0.88	0.00	7.22	141.06	2.00	0.00	0.88	0.00
7.38	139.87	2.00	0.00	0.87	0.00	7.55	134.09	2.00	0.00	0.87	0.00
7.71	124.98	2.00	0.00	0.87	0.00	7.87	116.99	2.00	0.00	0.87	0.00
8.04	117.28	2.00	0.00	0.86	0.00	8.20	124.61	2.00	0.00	0.86	0.00
8.37	129.20	2.00	0.00	0.86	0.00	8.53	130.27	2.00	0.00	0.86	0.00
8.69	126.08	2.00	0.00	0.85	0.00	8.86	121.38	2.00	0.00	0.85	0.00
9.02	112.02	2.00	0.00	0.85	0.00	9.19	104.35	2.00	0.00	0.84	0.00
9.35	103.57	2.00	0.00	0.84	0.00	9.51	114.50	2.00	0.00	0.84	0.00
9.68	123.86	2.00	0.00	0.84	0.00	9.84	129.17	2.00	0.00	0.83	0.00
10.01	124.29	2.00	0.00	0.83	0.00	10.17	124.92	2.00	0.00	0.83	0.00
10.33	124.17	2.00	0.00	0.82	0.00	10.50	123.57	0.32	1.61	0.82	0.03
10.66	122.42	0.31	1.62	0.82	0.03	10.83	130.65	0.36	1.53	0.82	0.03
10.99	136.79	0.39	1.47	0.81	0.03	11.15	141.87	0.42	1.42	0.81	0.03
11.32	136.87	0.39	1.46	0.81	0.03	11.48	143.79	2.00	0.00	0.81	0.00
11.65	152.27	2.00	0.00	0.80	0.00	11.81	165.65	2.00	0.00	0.80	0.00
11.98	171.12	2.00	0.00	0.80	0.00	12.14	183.63	2.00	0.00	0.79	0.00
12.30	221.83	2.00	0.00	0.79	0.00	12.47	251.75	2.00	0.00	0.79	0.00
12.63	244.32	2.00	0.00	0.79	0.00	12.80	226.71	2.00	0.00	0.78	0.00
12.96	218.97	2.00	0.00	0.78	0.00	13.12	224.26	2.00	0.00	0.78	0.00
13.29	227.29	2.00	0.00	0.77	0.00	13.45	221.09	2.00	0.00	0.77	0.00
13.62	202.72	2.00	0.00	0.77	0.00	13.78	180.94	2.00	0.00	0.77	0.00
13.94	161.61	2.00	0.00	0.76	0.00	14.11	133.44	2.00	0.00	0.76	0.00
14.27	99.39	2.00	0.00	0.76	0.00	14.44	85.66	2.00	0.00	0.76	0.00
14.60	95.40	2.00	0.00	0.75	0.00	14.76	111.39	2.00	0.00	0.75	0.00
14.93	120.77	2.00	0.00	0.75	0.00	15.09	125.63	2.00	0.00	0.74	0.00
15.26	124.06	2.00	0.00	0.74	0.00	15.42	127.53	2.00	0.00	0.74	0.00
15.58	131.10	2.00	0.00	0.74	0.00	15.75	136.96	2.00	0.00	0.73	0.00
15.91	139.38	2.00	0.00	0.73	0.00	16.08	139.28	2.00	0.00	0.73	0.00
16.24	139.82	2.00	0.00	0.72	0.00	16.40	137.20	2.00	0.00	0.72	0.00
16.57	128.46	2.00	0.00	0.72	0.00	16.73	114.91	2.00	0.00	0.72	0.00
16.90	112.59	2.00	0.00	0.71	0.00	17.06	123.70	2.00	0.00	0.71	0.00
17.22	140.04	2.00	0.00	0.71	0.00	17.39	152.57	2.00	0.00	0.71	0.00
17.55	159.13	2.00	0.00	0.70	0.00	17.72	159.97	2.00	0.00	0.70	0.00
17.88	154.29	2.00	0.00	0.70	0.00	18.04	147.53	2.00	0.00	0.69	0.00
18.21	144.95	2.00	0.00	0.69	0.00	18.37	148.91	2.00	0.00	0.69	0.00
18.54	150.87	2.00	0.00	0.69	0.00	18.70	145.65	2.00	0.00	0.68	0.00
18.86	134.86	2.00	0.00	0.68	0.00	19.03	130.05	2.00	0.00	0.68	0.00
19.19	129.09	2.00	0.00	0.67	0.00	19.36	129.64	2.00	0.00	0.67	0.00
19.52	126.18	2.00	0.00	0.67	0.00	19.69	123.59	0.27	1.31	0.67	0.03
19.85	123.98	0.28	1.30	0.66	0.03	20.01	122.11	0.27	1.31	0.66	0.03
20.18	116.63	0.24	1.36	0.66	0.03	20.34	111.33	0.22	1.40	0.66	0.03
20.51	113.08	0.23	1.38	0.65	0.03	20.67	115.99	0.24	1.34	0.65	0.03

:: Post-earthquake settlement due to soil liquefaction :: (continued)

Depth (ft)	Q _{u,cs}	FS	e _v (%)	DF	Settlement (in)	Depth (ft)	Q _{u,cs}	FS	e _v (%)	DF	Settlement (in)
20.83	118.63	2.00	0.00	0.65	0.00	21.00	115.89	2.00	0.00	0.64	0.00
21.16	121.59	2.00	0.00	0.64	0.00	21.33	117.86	2.00	0.00	0.64	0.00
21.49	110.90	2.00	0.00	0.64	0.00	21.65	101.15	2.00	0.00	0.63	0.00
21.82	98.28	2.00	0.00	0.63	0.00	21.98	90.87	2.00	0.00	0.63	0.00
22.15	74.54	2.00	0.00	0.62	0.00	22.31	59.81	2.00	0.00	0.62	0.00
22.47	60.80	2.00	0.00	0.62	0.00	22.64	70.02	2.00	0.00	0.62	0.00
22.80	88.63	2.00	0.00	0.61	0.00	22.97	100.58	2.00	0.00	0.61	0.00
23.13	105.46	2.00	0.00	0.61	0.00	23.29	107.47	2.00	0.00	0.61	0.00
23.46	108.73	2.00	0.00	0.60	0.00	23.62	111.23	2.00	0.00	0.60	0.00
23.79	107.35	2.00	0.00	0.60	0.00	23.95	110.23	2.00	0.00	0.59	0.00
24.11	123.82	2.00	0.00	0.59	0.00	24.28	142.91	2.00	0.00	0.59	0.00
24.44	151.22	2.00	0.00	0.59	0.00	24.61	155.69	2.00	0.00	0.58	0.00
24.77	152.35	2.00	0.00	0.58	0.00	24.93	144.88	2.00	0.00	0.58	0.00
25.10	130.89	2.00	0.00	0.57	0.00	25.26	120.49	2.00	0.00	0.57	0.00
25.43	121.01	2.00	0.00	0.57	0.00	25.59	130.03	2.00	0.00	0.57	0.00
25.75	141.65	2.00	0.00	0.56	0.00	25.92	148.94	2.00	0.00	0.56	0.00
26.08	152.01	2.00	0.00	0.56	0.00	26.25	152.42	2.00	0.00	0.56	0.00
26.41	151.61	2.00	0.00	0.55	0.00	26.57	149.88	2.00	0.00	0.55	0.00
26.74	149.31	2.00	0.00	0.55	0.00	26.90	150.54	2.00	0.00	0.54	0.00
27.07	153.13	2.00	0.00	0.54	0.00	27.23	155.86	2.00	0.00	0.54	0.00
27.40	157.99	2.00	0.00	0.54	0.00	27.56	156.30	2.00	0.00	0.53	0.00
27.72	150.82	2.00	0.00	0.53	0.00	27.89	143.56	2.00	0.00	0.53	0.00
28.05	133.94	2.00	0.00	0.52	0.00	28.22	118.85	2.00	0.00	0.52	0.00
28.38	103.13	2.00	0.00	0.52	0.00	28.54	96.90	2.00	0.00	0.52	0.00
28.71	103.28	2.00	0.00	0.51	0.00	28.87	111.96	2.00	0.00	0.51	0.00
29.04	116.80	2.00	0.00	0.51	0.00	29.20	119.01	2.00	0.00	0.51	0.00
29.36	122.33	2.00	0.00	0.50	0.00	29.53	125.94	2.00	0.00	0.50	0.00
29.69	127.03	2.00	0.00	0.50	0.00	29.86	124.30	2.00	0.00	0.49	0.00
30.02	120.36	2.00	0.00	0.49	0.00	30.18	117.21	2.00	0.00	0.49	0.00
30.35	116.06	2.00	0.00	0.49	0.00	30.51	113.88	2.00	0.00	0.48	0.00
30.68	116.12	2.00	0.00	0.48	0.00	30.84	122.20	2.00	0.00	0.48	0.00
31.00	136.05	2.00	0.00	0.47	0.00	31.17	146.22	2.00	0.00	0.47	0.00
31.33	148.73	2.00	0.00	0.47	0.00	31.50	139.78	2.00	0.00	0.47	0.00
31.66	125.67	2.00	0.00	0.46	0.00	31.82	111.57	2.00	0.00	0.46	0.00
31.99	102.80	2.00	0.00	0.46	0.00	32.15	101.55	2.00	0.00	0.46	0.00
32.32	109.21	2.00	0.00	0.45	0.00	32.48	118.94	2.00	0.00	0.45	0.00
32.64	123.89	2.00	0.00	0.45	0.00	32.81	120.80	2.00	0.00	0.44	0.00
32.97	113.15	2.00	0.00	0.44	0.00	33.14	105.15	2.00	0.00	0.44	0.00
33.30	103.45	2.00	0.00	0.44	0.00	33.46	104.94	2.00	0.00	0.43	0.00
33.63	105.01	2.00	0.00	0.43	0.00	33.79	97.93	2.00	0.00	0.43	0.00
33.96	87.52	2.00	0.00	0.42	0.00	34.12	79.73	2.00	0.00	0.42	0.00
34.28	85.24	2.00	0.00	0.42	0.00	34.45	99.19	2.00	0.00	0.42	0.00
34.61	114.55	2.00	0.00	0.41	0.00	34.78	123.21	2.00	0.00	0.41	0.00
34.94	128.04	2.00	0.00	0.41	0.00	35.10	130.78	2.00	0.00	0.41	0.00
35.27	131.30	2.00	0.00	0.40	0.00	35.43	131.63	2.00	0.00	0.40	0.00
35.60	132.36	2.00	0.00	0.40	0.00	35.76	134.07	2.00	0.00	0.39	0.00
35.93	131.92	2.00	0.00	0.39	0.00	36.09	130.78	2.00	0.00	0.39	0.00
36.25	132.96	2.00	0.00	0.39	0.00	36.42	138.94	2.00	0.00	0.38	0.00

:: Post-earthquake settlement due to soil liquefaction :: (continued)

Depth (ft)	$Q_{m,cs}$	FS	e_v (%)	DF	Settlement (in)	Depth (ft)	$Q_{m,cs}$	FS	e_v (%)	DF	Settlement (in)
36.58	142.59	2.00	0.00	0.38	0.00	36.75	144.22	2.00	0.00	0.38	0.00
36.91	140.29	2.00	0.00	0.37	0.00	37.07	132.10	2.00	0.00	0.37	0.00
37.24	120.59	2.00	0.00	0.37	0.00	37.40	114.81	2.00	0.00	0.37	0.00
37.57	111.27	2.00	0.00	0.36	0.00	37.73	104.28	2.00	0.00	0.36	0.00
37.89	92.63	2.00	0.00	0.36	0.00	38.06	83.48	2.00	0.00	0.35	0.00
38.22	85.41	2.00	0.00	0.35	0.00	38.39	98.52	2.00	0.00	0.35	0.00
38.55	115.37	2.00	0.00	0.35	0.00	38.71	129.35	2.00	0.00	0.34	0.00
38.88	136.01	2.00	0.00	0.34	0.00	39.04	136.80	2.00	0.00	0.34	0.00
39.21	134.48	2.00	0.00	0.34	0.00	39.37	130.71	2.00	0.00	0.33	0.00
39.53	128.16	2.00	0.00	0.33	0.00	39.70	124.31	2.00	0.00	0.33	0.00
39.86	117.62	2.00	0.00	0.32	0.00	40.03	105.01	2.00	0.00	0.32	0.00
40.19	92.47	2.00	0.00	0.32	0.00	40.35	87.54	2.00	0.00	0.32	0.00
40.52	93.78	2.00	0.00	0.31	0.00	40.68	103.74	2.00	0.00	0.31	0.00
40.85	107.92	2.00	0.00	0.31	0.00	41.01	112.44	2.00	0.00	0.30	0.00
41.17	113.00	2.00	0.00	0.30	0.00	41.34	113.46	2.00	0.00	0.30	0.00
41.50	108.81	2.00	0.00	0.30	0.00	41.67	104.64	2.00	0.00	0.29	0.00
41.83	99.81	2.00	0.00	0.29	0.00	41.99	94.19	2.00	0.00	0.29	0.00
42.16	90.09	2.00	0.00	0.29	0.00	42.32	86.95	2.00	0.00	0.28	0.00
42.49	81.50	2.00	0.00	0.28	0.00	42.65	71.95	2.00	0.00	0.28	0.00
42.81	62.15	2.00	0.00	0.27	0.00	42.98	60.29	2.00	0.00	0.27	0.00
43.14	63.90	2.00	0.00	0.27	0.00	43.31	72.63	2.00	0.00	0.27	0.00
43.47	88.47	2.00	0.00	0.26	0.00	43.64	105.66	2.00	0.00	0.26	0.00
43.80	115.11	2.00	0.00	0.26	0.00	43.96	110.72	2.00	0.00	0.25	0.00
44.13	107.87	2.00	0.00	0.25	0.00	44.29	108.63	0.21	0.54	0.25	0.01
44.46	114.07	0.23	0.52	0.25	0.01	44.62	116.81	0.24	0.50	0.24	0.01
44.78	123.62	0.27	0.47	0.24	0.01	44.95	140.08	0.36	0.42	0.24	0.01
45.11	165.29	0.53	0.36	0.24	0.01	45.28	198.64	0.86	0.13	0.23	0.00
45.44	233.24	2.00	0.00	0.23	0.00	45.60	244.81	2.00	0.00	0.23	0.00
45.77	228.84	2.00	0.00	0.22	0.00	45.93	195.28	0.82	0.17	0.22	0.00
46.10	163.80	0.52	0.34	0.22	0.01	46.26	148.36	0.41	0.37	0.22	0.01
46.42	153.39	0.44	0.35	0.21	0.01	46.59	168.72	0.56	0.30	0.21	0.01
46.75	180.24	0.67	0.22	0.21	0.00	46.92	182.64	0.69	0.21	0.20	0.00
47.08	177.89	0.65	0.27	0.20	0.01	47.24	175.40	0.63	0.27	0.20	0.01
47.41	174.89	0.62	0.27	0.20	0.01	47.57	175.07	0.62	0.26	0.19	0.01
47.74	172.18	0.60	0.26	0.19	0.01	47.90	166.91	0.55	0.27	0.19	0.01
48.06	157.87	0.48	0.30	0.19	0.01	48.23	144.68	0.39	0.32	0.18	0.01
48.39	131.29	0.32	0.34	0.18	0.01	48.56	125.86	0.29	0.34	0.18	0.01
48.72	127.48	0.30	0.33	0.17	0.01	48.88	134.61	0.33	0.31	0.17	0.01
49.05	140.92	0.37	0.30	0.17	0.01	49.21	146.62	0.41	0.28	0.17	0.01
49.38	147.91	0.42	0.28	0.16	0.01	49.54	145.19	0.40	0.28	0.16	0.01
49.70	141.26	0.38	0.28	0.16	0.01	49.87	134.20	0.33	0.28	0.15	0.01
50.03	128.49	0.31	0.29	0.15	0.01						

Total estimated settlement: 0.57

Abbreviations

$Q_{m,cs}$:	Equivalent clean sand normalized cone resistance
FS:	Factor of safety against liquefaction
e_v (%):	Post-liquefaction volumetric strain
DF:	e_v depth weighting factor
Settlement:	Calculated settlement

APPENDIX C

REFERENCES

- American Concrete Institute (ACI), 2013, ACI Manual of Concrete Practice 302.1R-04
- American Society of Civil Engineers (ASCE), 2010, Minimum Design Loads for Buildings and Other Structures: ASCE Standard 7-10.
- California Building Standards Commission, 2017, 2016 California Building Code. California Code of Regulations, Title 24, Part 2, Vol. 2 of 2.
- Caltrans, 2012, Highway Design Manual.
- California Division of Mines and Geology (CDMG), 1996, California Fault Parameters: available at <http://www.consrv.ca.gov/dmg/shezp/ftindex.html>.
- California Geological Survey (CGS), 2008, Guidelines for Evaluating and Mitigating Seismic Hazards in California, Special Publication 117A, 98p.
- California Geological Survey (CGS), 2018, Fault Activity Map of California <http://www.quake.ca.gov/gmaps/FAM/faultactivitymap.html#>.
- California Geological Survey (CGS), 2018, Alquist-Priolo Earthquake Fault Zone Maps. <http://maps.conservation.ca.gov/cgs/informationwarehouse/index.html?map=regulatorymaps>
- Cetin, K. O., Seed, R. B., Der Kiureghian, A., Tokimatsu, K., Harder, L. F., Jr., Kayen, R. E., and Moss, R. E. S., 2004, Standard penetration test-based probabilistic and deterministic assessment of seismic soil liquefaction potential: ASCE JGGE, Vol., 130, No. 12, p. 1314-1340.
- Geologismiki, 2017, CLiq Computer Program, www.geologismiki.gr
- Ishihara, K. (1985), Stability of natural deposits during earthquakes, Proc. 11th Int. Conf. On Soil Mech. And Found. Engrg., Vol. 1, A. A. Balkema, Rotterdam, The Netherlands, 321-376.
- Jones, A. L., 2003, An Analytical Model and Application for Ground Surface Effects from Liquefaction, PhD. Dissertation, University of Washington, 362 p.
- McCrink, T. P., Pridmore, C. L., Tinsley, J. C., Sickler, R. R., Brandenburg, S. J., and Stewart, J. P., 2011, Liquefaction and Other Ground Failures in Imperial County, California, from the April 4, 2010, El Mayor—Cucapah Earthquake, CGS Special Report 220, USGS Open File Report 2011-1071, 84 p.

- Morton, P. K., 1977, Geology and mineral resources of Imperial County, California: California Division of Mines and Geology, County Report No. 7, 104 p.
- Post-Tensioning Institute (PTI), 2007a, Standard Requirements for Analysis of Shallow Concrete Foundations on Expansive Soils (3rd Edition).
- Post-Tensioning Institute (PTI), 2007b, Standard Requirements for Design of Shallow Post-Tensioned Concrete Foundations on Expansive Soils (2nd Edition).
- Robertson, P. K., 2014, Seismic liquefaction CPT-based methods: EERI 1st Workshop on Geotechnical Earthquake Engineering – Liquefaction Evaluation, Mapping, Simulation and Mitigation. UC San Diego Campus, 10/12/2014.
- Robertson, P. K. and Wride, C. E., 1997, Cyclic Liquefaction and its Evaluation based on the SPT and CPT, Proceeding of the NCEER Workshop on Evaluation of Liquefaction Resistance of Soils, NCEER Technical Report 97-0022, p. 41-88.
- Rymer, M.J., Treiman, J.A., Kendrick, K.J., Lienkaemper, J.J., Weldon, R.J., Bilham, R., Wei, M., Fielding, E.J., Hernandez, J.L., Olson, B.P.E., Irvine, P.J., Knepprath, N., Siokler, R.R., Tong, .X., and Siem, M.E., 2011, Triggered surface slips in southern California associated with the 2010 El Mayor-Cucapah, Baja California, Mexico, earthquake: U.S. Geological Survey Open-File Report 2010-1333 and California Geological Survey Special Report 221, 62 p., available at <http://pubs.usgs.gov/of/2010/1333/>.
- U.S. Geological Survey (USGS), 1990, The San Andreas Fault System, California, Professional Paper 1515.
- U.S. Geological Survey (USGS), 2017, US Seismic Design Maps Web Application, available at <http://geohazards.usgs.gov/designmaps/us/application.php>
- Wire Reinforcement Institute (WRI/CRSI), 2003, Design of Slab-on-Ground Foundations, Tech Facts TF 700-R-03, 23 p.
- Youd, T. L., 2005, Liquefaction-induced flow, lateral spread, and ground oscillation, GSA Abstracts with Programs, Vol. 37, No. 7, p. 252.
- Youd, T. L. and Garris, C. T., 1995, Liquefaction induced ground surface disruption: ASCE Geotechnical Journal, Vol. 121, No. 11.
- Zimmerman, R. P., 1981, Soil survey of Imperial County, California, Imperial Valley Area: U.S. Dept. of Agriculture Soil Conservation Service, 112 p.

APPENDIX D

Geotechnical Report

**JR Simplot Fertilizer Terminal
North of Harris Road (West of UPRR)
Imperial, CA**

Prepared for:

DD&E
1065 Main Street
El Centro, CA 92243

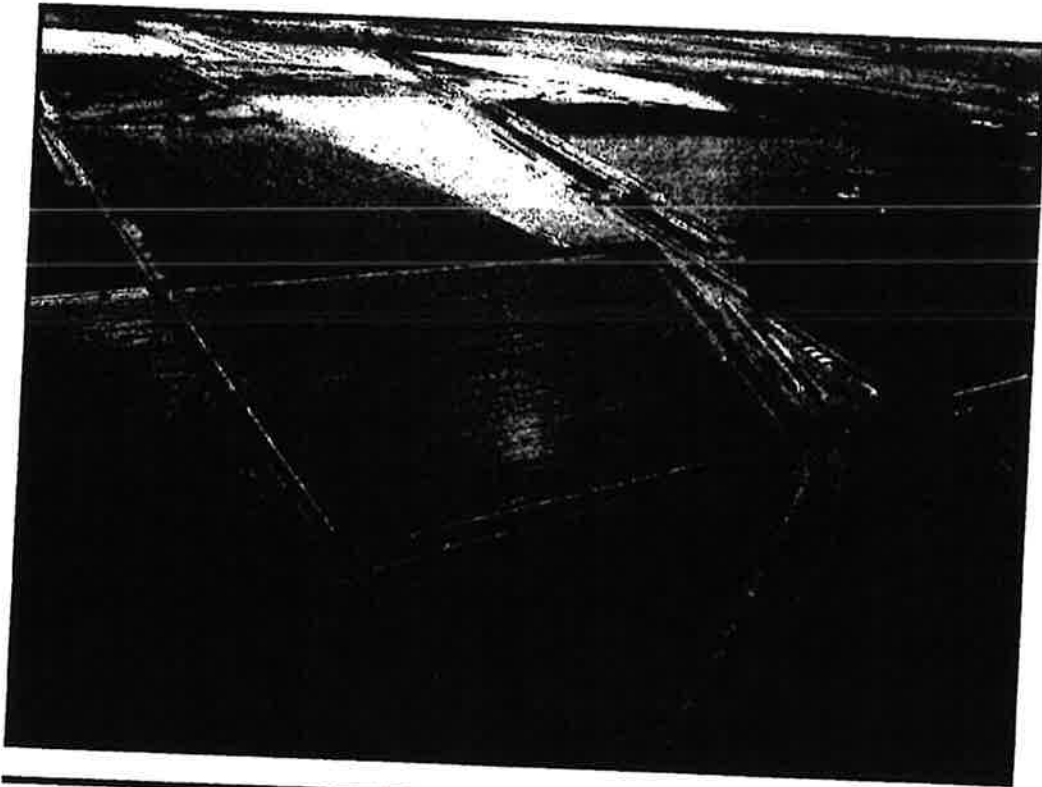

LANDMARK
Geo Engineers and Geologists

Prepared by:

Landmark Consultants, Inc.
780 N. 4th Street
El Centro, CA 92243
(760) 370-3000

January 2008



January 18, 2008

Mr. Peter Fogec
Development Design & Engineering
1065 Main Street
El Centro, CA 92243

780 N 4th Street
El Centro, CA 92243
(760) 370-3000
(760) 337-8900 fax

77-948 Wildcat Drive
Palm Desert, CA 92211
(760) 360-0865
(760) 360-0521 fax

**Geotechnical Investigation
JR Simplot Fertilizer Terminal
North of Harris Road (West of UPRR)
Tract 183, T.14S – R.14E, SBM
Imperial County, California
LCI Report No. LE07435**

Dear Mr. Fogec:

This geotechnical report is provided for design and construction of the proposed JR Simplot Fertilizer Terminal located north of Harris Road along the west side of the Union Pacific Railroad tracks north of Imperial, California. Our geotechnical investigation was conducted in response to your request for our services. The enclosed report describes our soil engineering investigation and presents our professional opinions regarding geotechnical conditions at the site to be considered in the design and construction of the project.

This summary presents *selected* elements of our findings and recommendations only. It *does not* present crucial details needed for the proper application of our findings and recommendations. Our findings, recommendations, and application options are related *only through reading the full report*, and are best evaluated with the active participation of the engineer of record who developed them.

The findings of this study indicate that the site is, in general, predominantly underlain by clays of moderate to high expansion potential that will require foundations and slabs-on-grade designed to resist expansive soil heave (2007 California Building Code (CBC) Chapter 18, Section 1805.8). The CBC design method requires grade-beam stiffening of floor slabs at a maximum spacing of 18 feet on center, grade-beam stiffened post-tensioned slabs or flat-plate structural slabs. Design and construction of site improvements (concrete flatwork, curbs, housekeeping slabs, etc.) should include provisions to mitigate clay soil movement. Additionally, the weak clay subgrade soil requires thickened structural sections for pavements.

In order to reduce settlement in some structures to generally accepted limits, existing soft, compressible clays may be strengthened by soil improvement (soil mixing, stone columns, geopiers, etc.) or by placement of a deep foundation system like driven piles or drilled piers. These options are discussed in the report.

The soil is highly corrosive to metals and contains sufficient sulfates and chlorides to require special concrete mixes (4,500 psi strength with 0.45 maximum water cement ratio and Type V cement) and protection of embedded steel components when concrete is placed in contact with native soil.

The site is located approximately 1.2 miles from a major fault (Imperial Fault) with potential of a magnitude 7 event. Strong groundshaking will occur at this site and special structural designs will be required.

Evaluation of liquefaction potential at the site indicates that 1 to 4 foot thick, isolated, interbedded layers of silt and silty sand at a depth between 10 to 14 feet and 44 to 50 feet may liquefy under seismically induced groundshaking, potentially resulting in an estimated ¾ to 2 inches of deep seated settlement. There is a 10-foot layer of non-liquefiable clay soils above any potentially liquefiable soil; therefore, it is unlikely that there will be rapid deformation or punching bearing failures of the surface soils should liquefaction occur.

We did not encounter soil conditions that would preclude implementation of the proposed project provided the recommendations contained in this report are implemented in the design and construction of this project.

We appreciate the opportunity to provide our findings and professional opinions regarding geotechnical conditions at the site. If you have any questions or comments regarding our findings, please call our office at (760) 360-0665.

Respectfully Submitted,
Landmark Consultants, Inc.

Steven K. Williams, CEG
Senior Engineering Geologist



Julian R. Avalos, EIT
Staff Engineer

Jeffrey O. Lyon, PE
President



<u>TABLE OF CONTENTS</u>		Page
Section 1.....		1
INTRODUCTION.....		1
1.1 Project Description.....		1
1.2 Purpose and Scope of Work.....		1
1.3 Authorization.....		3
Section 2.....		4
METHODS OF INVESTIGATION.....		4
2.1 Field Exploration.....		4
2.2 Laboratory Testing.....		6
Section 3.....		7
DISCUSSION.....		7
3.1 Site Conditions.....		7
3.2 Geologic Setting.....		7
3.3 Seismicity and Faulting.....		8
3.4 Site Acceleration and UBC Seismic Coefficients.....		9
3.5 Subsurface Soil.....		10
3.6 Groundwater.....		11
3.7 Liquefaction.....		12
Section 4.....		15
RECOMMENDATIONS.....		15
4.1 Site Preparation.....		15
4.2 Spread Foundations and Settlements.....		19
4.3 Steel Tank Foundations and Settlements.....		22
4.4 Slabs-On-Grade.....		25
4.5 Concrete Mixes and Corrosivity.....		26
4.6 Excavations.....		27
4.7 Lateral Earth Pressures.....		28
4.8 Seismic Design.....		29
4.9 Pavements.....		29
4.10 Railroad Spur Line Subgrade Preparation.....		31
Section 5.....		32
LIMITATIONS AND ADDITIONAL SERVICES.....		32
5.1 Limitations.....		32
5.2 Additional Services.....		33

APPENDICES

- APPENDIX A: Vicinity and Site Maps**
- APPENDIX B: Subsurface Soil Logs and Soil Key**
- APPENDIX C: Laboratory Test Results**
- APPENDIX D: Pipe Bedding and Trench Backfill Recommendations**
- APPENDIX E: References**

Section 1

INTRODUCTION

1.1 Project Description

This report presents the findings of our geotechnical investigation for the proposed JR Simplot Fertilizer Terminal located on the 40 acre agricultural field north of Harris Road along the west side of the Union Pacific Railroad tracks and Newside Drain No. 1 north of Imperial, California (See Vicinity Map, Plate A-1). The proposed development will consist of several large liquid fertilizer tanks and two large dry fertilizer warehouse buildings. Also, the proposed facility will have an administration office, truck scale, and associated internal roadways. A new rail spur is planned to be located along the north side of the project site.

The office building is planned to consist of slab-on-grade foundation with masonry and/or wood-frame concrete construction. Footing loads at exterior bearing walls are estimated at 1 to 5 kips per lineal foot. The warehouses are planned to consist of slab-on-grade foundation with masonry and/or steel-frame construction. Footing loads at exterior bearing walls are estimated at 1 to 5 kips per lineal foot. Column loads are estimated to range from 5 to 100 kips. The dimensions for the proposed steel storage tanks were not provided at the time that this report was prepared. The estimated loads imposed at ground surface by the loaded tanks have been estimated to range from 1,000 to 4,000 pounds per square foot.

If structural loads exceed those stated above, we should be notified so we may evaluate their impact on foundation settlement and bearing capacity. Site development will include deep foundation installations, building support pad preparation, underground utility installation, roadway and concrete flatwork placement.

1.2 Purpose and Scope of Work

The purpose of this geotechnical study was to investigate the upper 51.5 feet of subsurface soil at selected locations within the site for evaluation of physical/engineering properties. From the subsequent field and laboratory data, professional opinions were developed and are provided in this report regarding geotechnical conditions at this site and the effect on design and construction.

The scope of our services consisted of the following:

- ▶ Field exploration and in-situ testing of the site soils at selected locations and depths.
- ▶ Laboratory testing for physical and/or chemical properties of selected samples.
- ▶ Review of the available literature and publications pertaining to local geology, faulting, and seismicity.
- ▶ Engineering analysis and evaluation of the data collected.
- ▶ Preparation of this report presenting our findings, professional opinions, and recommendations for the geotechnical aspects of project design and construction.

This report addresses the following geotechnical issues:

- ▶ Subsurface soil and groundwater conditions
- ▶ Site geology, regional faulting and seismicity, near source factors, and site seismic accelerations
- ▶ Liquefaction potential and its mitigation
- ▶ Expansive soil and methods of mitigation
- ▶ Aggressive soil conditions to metals and concrete

Professional opinions with regard to the above issues are presented for the following:

- ▶ Site grading and earthwork
- ▶ Building pad and foundation subgrade preparation
- ▶ Allowable soil bearing pressures and expected settlements
- ▶ Soil improvement methods
- ▶ Deep foundations (drilled piers/driven piles)
- ▶ Concrete slabs-on-grade
- ▶ Lateral earth pressures
- ▶ Excavation conditions and buried utility installations
- ▶ Mitigation of the potential effects of salt concentrations in native soil to concrete mixes and steel reinforcement
- ▶ Seismic design parameters
- ▶ Pavement structural sections
- ▶ Rail bed subgrade/subbase requirements

Our scope of work for this report did not include an evaluation of the site for the presence of environmentally hazardous materials or conditions.

1.3 Authorization

Mr. Tom DuBose, President of Development Design and Engineering, provided authorization by written agreement to proceed with our work on November 13, 2007. We conducted our work according to our written proposal dated October 1, 2007.

Section 2
METHODS OF INVESTIGATION

2.1 Field Exploration

Subsurface exploration was performed on November 19, 2007 using Holguin, Fahan, & Associates, Inc. of Cypress, California to advance four (4) electric cone penetrometer (CPT) soundings to an approximate depth of 50 feet below existing ground surface. The soundings were made at the locations shown on the Site and Exploration Plan (Plate A-2). The approximate sounding locations were established in the field and plotted on the site map by sighting to discernable site features.

CPT soundings provide a continuous profile of the soil stratigraphy with readings every 2.5cm (1 inch) in depth. Direct sampling for visual and physical confirmation of soil properties has been used by our firm to establish direct correlations with CPT exploration in this geographical region.

The CPT exploration was conducted by hydraulically advancing an instrumented Hogentogler 10cm² conical probe into the ground at a rate of 2cm per second using a 23-ton truck as a reaction mass. An electronic data acquisition system recorded a nearly continuous log of the resistance of the soil against the cone tip (Q_c) and soil friction against the cone sleeve (F_s) as the probe was advanced. Empirical relationships (Robertson and Campanella, 1989) were then applied to the data to give a continuous profile of the soil stratigraphy. Interpretation of CPT data provides correlations for SPT blow count, phi (ϕ) angle (soil friction angle), undrained shear strength (S_u) of clays and over-consolidation ratio (OCR). These correlations may then be used to evaluate vertical and lateral soil bearing capacities and consolidation characteristics of the subsurface soil.

Additional subsurface exploration was performed on November 20, 2007 using 2R Drilling of Ontario, California to advance eight (8) borings to depths of 5 to 51.5 feet below existing ground surface. The borings were advanced with a truck-mounted, CME 55 drill rig using 8-inch diameter, hollow-stem, continuous-flight augers. The approximate boring locations were established in the field and plotted on the site map by sighting to discernable site features. The boring locations are shown on the Site and Exploration Plan (Plate A-2).

A staff engineer observed the drilling operations and maintained a log of the soil encountered and sampling depths, visually classified the soil encountered during drilling in accordance with the Unified Soil Classification System, and obtained drive tube and bulk samples of the subsurface materials at selected intervals. Relatively undisturbed soil samples were retrieved using a 2-inch outside diameter (OD) split-spoon sampler or a 3-inch OD Modified California Split-Barrel (ring) sampler. The samples were obtained by driving the sampler ahead of the auger tip at selected depths. The drill rig was equipped with a 140-pound CME automatic hammer for conducting Standard Penetration Tests (SPT). The number of blows required to drive the samplers 12 inches into the soil is recorded on the boring logs as “blows per foot”. Blow counts reported on the boring logs represent the field blow counts. No corrections have been applied for effects of overburden pressure, automatic hammer drive energy, drill rod lengths, liners, and sampler diameter. Pocket penetrometer readings were also obtained to evaluate the stiffness of cohesive soils retrieved from sampler barrels.

After logging and sampling the soil, the exploratory borings were backfilled with the excavated material. The backfill was loosely placed and was not compacted to the requirements specified for engineered fill.

The subsurface borings logs and interpretive logs of the CPT soundings are presented on Plates B-1 through B-12 in Appendix B. A key to the interpretation of CPT soundings and the borings logs are presented on Plates B-13 and B-14, respectively. The stratification lines shown on the subsurface logs represent the approximate boundaries between the various strata. However, the transition from one stratum to another may be gradual over some range of depth.

2.2 Laboratory Testing

Laboratory tests were conducted on selected bulk (auger cuttings) and relatively undisturbed soil samples obtained in thin-wall tubes from the soil boring to aid in classification and evaluation of selected engineering properties of the site soils. The tests were conducted in general conformance to the procedures of the American Society for Testing and Materials (ASTM) or other standardized methods as referenced below. The laboratory testing program consisted of the following tests:

- ▶ Plasticity Index (ASTM D4318) – used for soil classification, settlement estimates and expansive soil design criteria.
- ▶ Particle Size Analyses (ASTM D422) – used for soil classification and liquefaction evaluation
- ▶ Unit Dry Densities (ASTM D2937) and Moisture Contents (ASTM D2216) – used for insitu soil parameters.
- ▶ One Dimensional Consolidation (ASTM D2435) – used for settlement estimates.
- ▶ Unconfined Compression (ASTM D2166) – used for soil strength estimates.
- ▶ R Value (ASTM D2844) – used for pavement structural section design
- ▶ Chemical Analyses (soluble sulfates & chlorides, pH, and resistivity) (Caltrans Methods) – used for concrete mix evaluations and corrosion protection requirements.

The laboratory test results are presented on the subsurface logs in Appendix B and on Plates C-1 through C-8 in Appendix C.

Engineering parameters of soil strength, compressibility and relative density utilized for developing design criteria provided within this report were either extrapolated from correlations with the subsurface CPT data or from data obtained from the field and laboratory testing program.

Section 3
DISCUSSION

3.1 Site Conditions

The project site is vacant, flat-lying with Sudan grass stubble covering the site and consists of approximately 40-acres of agricultural land. The project site is trapezoidal in plan view with the east side of the site angled to the northeast along the Newside Drain No. 1. The site is bounded on the south by Harris Road, a paved two-lane rural road (planned as a 4 to 6 lane county arterial) and the east by the Newside Drain, an earthen agricultural runoff water drainage ditch. The Newside Drain is approximately 8 feet deep. A concrete irrigation ditch is located along the north side of the site and a small earthen irrigation ditch is located on the west side of the site. The Holly Sugar sugar beet refining facility is located approximately ¼-mile north of the site. Agriculture fields are located to the north, south, east and west sides of the proposed project property.

The project site lies at an elevation of approximately 80 feet below mean sea level (El. 920 local datum) in the Imperial Valley region of the California low desert. The surrounding properties lie on terrain which is flat (planar), part of a large agricultural valley, which was previously an ancient lake bed covered with fresh water to an elevation of 43± feet above MSL. Annual rainfall in this arid region is less than 3 inches per year with four months of average summertime temperatures above 100 °F. Winter temperatures are mild, seldom reaching freezing.

3.2 Geologic Setting

The project site is located in the Imperial Valley portion of the Salton Trough physiographic province. The Salton Trough is a geologic structural depression resulting from large scale regional faulting. The trough is bounded on the northeast by the San Andreas Fault and Chocolate Mountains and the southwest by the Peninsular Range and faults of the San Jacinto Fault Zone. The Salton Trough represents the northward extension of the Gulf of California, containing both marine and non-marine sediments since the Miocene Epoch. Tectonic activity that formed the trough continues at a high rate as evidenced by deformed young sedimentary deposits and high levels of seismicity. Figure 1 shows the location of the site in relation to regional faults and physiographic features.

The Imperial Valley is directly underlain by lacustrine deposits, which consist of interbedded lenticular and tabular silt, sand, and clay. The Late Pleistocene to Holocene lake deposits are probably less than 100 feet thick and derived from periodic flooding of the Colorado River which intermittently formed a fresh water lake (Lake Cahuilla). Older deposits consist of Miocene to Pleistocene non-marine and marine sediments deposited during intrusions of the Gulf of California. Basement rock consisting of Mesozoic granite and Paleozoic metamorphic rocks are estimated to exist at depths between 15,000 - 20,000 feet.

3.3 Seismicity and Faulting

Faulting and Seismic Sources: We have performed a computer-aided search of known faults or seismic zones that lie within a 62 mile (100 kilometers) radius of the project site as shown on Figure 1 and Table 1. The search identifies known faults within this distance and computes deterministic ground accelerations at the site based on the maximum credible earthquake expected on each of the faults and the distance from the fault to the site. The Maximum Magnitude Earthquake (Mmax) listed was taken from published geologic information available for each fault (CDMG OFR 96-08 and Jennings, 1994).

Seismic Risk: The project site is located in the seismically active Imperial Valley of southern California and is considered likely to be subjected to moderate to strong ground motion from earthquakes in the region. The proposed site structures should be designed in accordance with the 2007 California Building Code (CBC) for a "Maximum Considered Earthquake" (MCE) and with the appropriate site coefficients. The MCE is defined as the ground motion having a 2 percent probability of being exceeded in 50 years.

Seismic Hazards.

- ▶ **Groundshaking.** The primary seismic hazard at the project site is the potential for strong groundshaking during earthquakes along the Imperial, Brawley, and Superstition Hills Faults. A further discussion of groundshaking follows in Section 3.4.
- ▶ **Surface Rupture.** The project site does not lie within a State of California, Alquist-Priolo Earthquake Fault Zone. Surface fault rupture is considered to be unlikely at the project site because of the well-delineated fault lines through the Imperial Valley as shown on USGS and CGS maps.

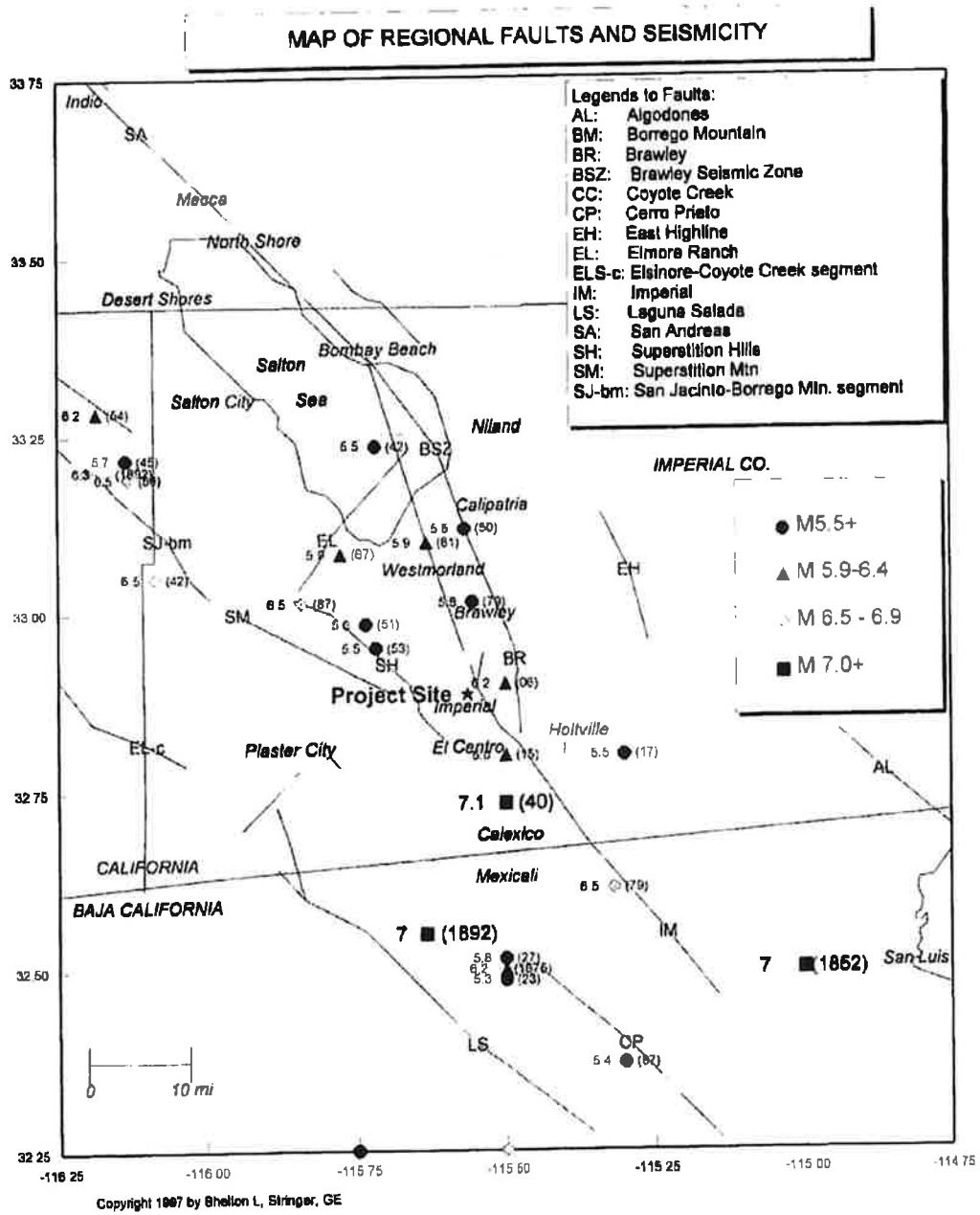

Faults and Seismic Zones from Jennings (1994), Earthquakes modified from Ellsworth (1990) catalog.

Figure 1. Map of Regional Faults and Seismicity

Table 1
FAULT PARAMETERS & DETERMINISTIC
ESTIMATES OF PEAK GROUND ACCELERATION (PGA)

Fault Name or Seismic Zone	Distance (mi) & Direction from Site	Fault Type		Fault Length (km)	Maximum Magnitude Mmax (Mw)	Avg Slip Rate (mm/yr)	Avg Return Period (yrs)	Date of Last Rupture (year)	Largest Historic Event >6.6M (year)	Est. Site PGA (g)
		(2)	(3)							
Reference Notes: (1)										
Imperial Valley Faults										
Imperial	1.2 ENE	A	B	62	7.0	20	79	1979	7.0 1940	0.59
Brawley Seismic Zone	4.1 N	B	B	42	6.4	25	24		5.9 1981	0.32
Brawley	4.8 ENE	B	B	14	7.0	20	---	1979	5.8 1979	0.41
East Highline Canal	18 ENE	C	C	22	6.3	1	774			0.11
Cerro Prieto	27 SSE	A	B	116	7.2	34	50	1980	7.1 1934	0.14
San Jacinto Fault System										
- Superstition Hills	4.6 SW	B	A	22	6.6	4	250	1987	6.5 1987	0.33
- Superstition Mtn.	7.2 W	B	A	23	6.6	5	500	1440 +/-		0.26
- Elmore Ranch	19 WNW	B	A	29	6.6	1	225	1987	5.9 1987	0.13
- Borrego Mtn	26 WNW	B	A	29	6.6	4	175		6.5 1942	0.10
- Anza Segment	41 NW	A	A	90	7.2	12	250	1918	6.8 1918	0.10
- Coyote Creek	45 WNW	B	A	40	6.8	4	175	1988	6.5 1968	0.08
- Hot Spgs-Buck Ridge	56 NW	B	A	70	6.5	2	354		6.3 1937	0.05
- Whole Zone	7.2 W	A	A	245	7.5	---	---			0.42
Elsinore Fault System										
- Laguna Salada	21 WSW	B	B	67	7.0	3.5	336		7.0 1891	0.15
- Coyote Segment	28 WSW	B	A	38	6.8	4	625			0.11
- Julian Segment	50 W	A	A	75	7.1	5	340			0.08
- Earthquake Valley	51 WNW	B	A	20	6.5	2	351			0.06
- Whole Zone	28 WSW	A	A	250	7.5	---	---			0.16
San Andreas Fault System										
- Coachella Valley	33 NNW	A	A	95	7.4	25	220	1690 +/-	6.5 1948	0.13
- Whole S. Calif. Zone	33 NNW	A	A	458	7.9	---	---	1857	7.8 1857	0.17

Notes:

- Jennings (1994) and CDMG (1996)
- CDMG (1996), where Type A faults -- slip rate >5 mm/yr and well constrained paleoseismic data
Type B faults -- all other faults.
- WGCEP (1995)
- CDMG (1996) based on Wells & Coppersmith (1994)
- Ellsworth Catalog in USGS PP 1515 (1990) and USBR (1976), Mw = moment magnitude.
- The deterministic estimates of the Site PGA are based on the attenuation relationship of:
Boore, Joyner, Fumal (1997)

The active Imperial Fault is located approximately 2 km northeast of the project site. The Imperial Fault is considered one of the most active faults in California, having experienced magnitude 6.5 and 6.9 earthquakes in 1979 and 1940, respectively. However, because of the high tectonic activity and deep alluvium of the region, we cannot preclude the potential for surface rupture on undiscovered or new faults that may underlie the site.

► **Liquefaction.** Liquefaction is a potential design consideration because of underlying saturated sandy substrata. The potential for liquefaction at the site is discussed in more detail in Section 3.7.

Other Secondary Hazards.

► **Landsliding.** The hazard of landsliding is unlikely due to the regional planar topography. No ancient landslides are shown on geologic maps of the region and no indications of landslides were observed during our site investigation. Small scale, localized slides were noted in the Newside Drain located along the east side of the site.

► **Volcanic hazards.** The site is not located in proximity to any known volcanically active area and the risk of volcanic hazards is considered very low.

► **Tsunamis, sieches, and flooding.** The site does not lie near any large bodies of water, so the threat of tsunami, sieches, or other seismically-induced flooding is unlikely.

► **Expansive soil.** In general, much of the near surface soils in the Imperial Valley consist of silty clays and clays which are moderate to highly expansive. The expansive soil conditions are discussed in more detail in Section 3.5.

3.4 Site Acceleration and UBC Seismic Coefficients

Site Acceleration: Deterministic horizontal peak ground accelerations (PGA) from maximum probable earthquakes on regional faults have been estimated and are included in Table 1. Ground motions are dependent primarily on the earthquake magnitude and distance to the seismogenic (rupture) zone. Accelerations also are dependent upon attenuation by rock and soil deposits, direction of rupture and type of fault; therefore, ground motions may vary considerably in the same general area.

We have used the computer program FRISKSP (Blake, 2000) to provide a probabilistic estimate of the site PGA using the attenuation relationship NEHRP D 250 of Boore, Joyner, and Fumal (1997). The PGA estimate for the Design Basis Earthquake (DBE) for the project site having a 10% probability of being exceeded in 50 years (return period of 475 years) is **0.89g**. The PGA estimate for the Maximum Considered Earthquake (MCE) for the project site having a 2% probability of being exceeded in 50 years (return period of 2,500 years) is **1.35g**.

2007 CBC (2006 IBC) Seismic Response Parameters: The 2007 California Building Code (CBC) seismic parameters are based on the Maximum Considered Earthquake with a ground motion that has a 2% probability of occurrence in 50 years. This follows the methodology of the 2006 International Building Code (IBC). Table 2 lists seismic and site coefficients given in Chapter 16 of the CBC. The site soils have been classified as Site Class D (soft soil profile).

Design earthquake ground motions are defined as the earthquake ground motions that are two-thirds (2/3) of the corresponding MCE ground motions. Design earthquake ground motion data are provided in Table 2.

3.5 Subsurface Soil

Subsurface soils encountered during the field exploration conducted on November 19 and 20, 2007 consist of dominantly stiff to very stiff clay and silty clay to a depth of 44 feet with an interbedded layer of silts/clayey silt and silty sand encountered at a depth of 10 feet to 14 feet. Sandy silt and silty sand was encountered at a depth of 44 to 51.5 feet, the maximum depth of exploration. The subsurface logs (Plates B-1 through B-12) depict the stratigraphic relationships of the various soil types.

The native surface clays exhibit moderate to high swell potential (Expansion Index, EI = 50 to 110) when correlated to Plasticity Index tests (ASTM D4318) performed on the native clays. The clay is expansive when wetted and can shrink with moisture loss (drying). Development of building foundations, concrete flatwork, and asphaltic concrete pavements should include provisions for mitigating potential swelling forces and reduction in soil strength, which can occur from saturation of the soil.

Table 2
2006 International Building Code (IBC) and ASCE 7-05 Seismic Parameters

Site Class:	D	IBC Reference
Latitude:	32.8856 N	Table 1613.5.2
Longitude:	-115.5636 W	

Maximum Considered Earthquake (MCE) Ground Motion

Short Period Spectral Response	S_a	1.94 g	Figure 1613.5(3)
1 second Spectral Response	S_1	0.77 g	Figure 1613.5(4)
Site Coefficient	F_a	1.00	Table 1613.5.3 (1)
Site Coefficient	F_v	1.50	Table 1613.5.3 (2)
Adjusted Short Period Spectral Response	S_{MS}	1.94 g	$= F_a * S_a$
Adjusted 1 second Spectral Response	S_{M1}	1.16 g	$= F_v * S_1$

Design Earthquake Ground Motion

Short Period Spectral Response	S_{DS}	1.30 g	$= 2/3 * S_{MS}$
1 second Spectral Response	S_{D1}	0.77 g	$= 2/3 * S_{M1}$
	T_0	0.12 sec	$= 0.2 * S_{D1} / S_{DS}$
	T_s	0.60 sec	$= S_{D1} / S_{DS}$

2006 IBC (ASCE 7-05) Design Response Spectrum

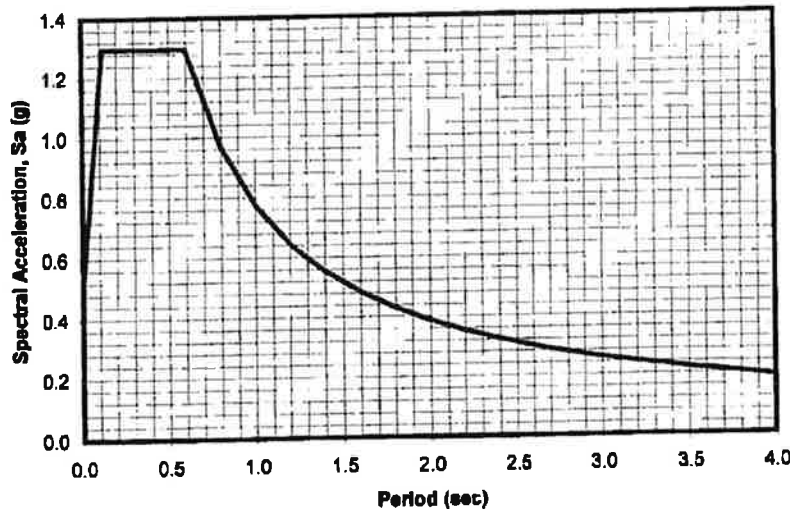

Period T (sec)	S_a (g)
0.00	0.52
0.05	0.84
0.12	1.30
0.20	1.30
0.30	1.30
0.60	1.30
0.80	0.97
1.00	0.77
1.20	0.65
1.40	0.55
1.80	0.48
1.80	0.43
2.00	0.39
2.20	0.35
2.40	0.32
2.60	0.30
2.80	0.28
3.00	0.26
3.50	0.22
4.00	0.19

Causes for soil saturation include landscape irrigation, broken utility lines, or capillary rise in moisture upon sealing the ground surface to evaporation. Moisture losses can occur with lack of landscape watering, close proximity of structures to downslopes and root system moisture extraction from deep rooted shrubs and trees placed near the foundations.

Typical measures used for commercial/industrial projects to remediate expansive soil include:

- ▶ moisture conditioning subgrade soils to a minimum of 5% above optimum moisture (ASTM D1557) within the drying zone of surface soils,
- ▶ treatment of silt/clay with lime to mitigate the shrink/swell forces of the clay soils when sulfate content of the soils is generally less than 7,500 ppm (4,000 ppm maximum at this site),
- ▶ capping silt/clay soil with a non-expansive sand layer of sufficient thickness (3 feet minimum) to reduce the effects of soil shrink/swell,
- ▶ design of foundations that are resistant to shrink/swell forces of silt/clay soil.

3.6 Groundwater

One (2) inch diameter piezometer was installed in Boring B-2 to a depth of 20 feet at the project site. Groundwater was encountered in the piezometer at a depth of 5 feet on November 22, 2007, two (2) days after placement of the piezometer. There is uncertainty in the accuracy of short-term water level measurements, particularly in fine-grained soil. Groundwater levels may fluctuate with precipitation, irrigation of adjacent properties, drainage, and site grading. The referenced groundwater level should not be interpreted to represent an accurate or permanent condition.

Subsurface agricultural tile drainage pipelines (4-inch diameter plastic or clay perforated pipelines encapsulated by sand/gravel envelope) exist at a depth of 6.0 to 8.0 feet below this site and have assisted in preventing an artificially high groundwater depth. Abandoning and plugging the subsurface drainage pipelines can allow groundwater levels to rise variably across the site. Cutting the subsurface tile drain pipelines with utility trenches will likely result in some localized trench flooding. Base line collectors should be crushed in-place and trench backfill compacted (85-90%).

The 4-inch lateral pipeline drains are not required to be removed or crushed in-place. The 4-inch pipelines should be plugged if encountered during site excavations. A copy of the tile drainage system plat as obtained from Imperial Irrigation District records is attached in Appendix A.

3.7 Liquefaction

Liquefaction occurs when granular soil below the water table is subjected to vibratory motions, such as produced by earthquakes. With strong ground shaking, an increase in pore water pressure develops as the soil tends to reduce in volume. If the increase in pore water pressure is sufficient to reduce the vertical effective stress (suspending the soil particles in water), the soil strength decreases and the soil behaves as a liquid (similar to quicksand). Liquefaction can produce excessive settlement, ground rupture, lateral spreading, or failure of shallow bearing foundations.

Four conditions are generally required for liquefaction to occur:

- (1) the soil must be saturated (relatively shallow groundwater);
- (2) the soil must be loosely packed (low to medium relative density);
- (3) the soil must be relatively cohesionless (not clayey); and
- (4) groundshaking of sufficient intensity must occur to function as a trigger mechanism.

All of these conditions exist to some degree at this site.

Methods of Analysis: Liquefaction potential at the project site was evaluated using the 1997 NCEER Liquefaction Workshop methods. The 1997 NCEER methods utilize direct SPT blow counts or CPT cone readings from site exploration and earthquake magnitude/PGA estimates from the seismic hazard analysis. The resistance to liquefaction is plotted on a chart of cyclic shear stress ratio (CSR) versus a corrected blow count $N_{1(60)}$ or Q_{CIN} . A ground acceleration of 0.89g was used in the analysis with a 5.0 foot groundwater depth.

Liquefaction induced settlements have been estimated using the 1987 Tokimatsu and Seed method. Fines content of liquefiable sands and silt increase the liquefaction resistance in that more cycles of ground motions are required to fully develop pore pressures.

The CPT tip pressures (Q_c) were adjusted to an equivalent clean sand pressure ($Q_{c(N_{cs})}$). The adjusted tip pressures were converted to equivalent clean sand blow counts ($N_{1(60)cs}$) prior to calculating settlements. A computed factor of safety less than 1.0 indicates a liquefiable condition.

The soil encountered at the points of exploration included saturated silts and silty sands that could liquefy during a CBC Design Basis Earthquake (7M – 0.90g) for a 10% risk in 50 years. Liquefaction can occur within isolated silts/clayey silts and silty sand layers (1 to 3 feet thick) between depths of 12 to 50 feet. The likely triggering mechanism for liquefaction appears to be strong groundshaking associated with the rupture of the Imperial, Brawley, and Superstition Hills Faults. The analysis is summarized in the table below.

Table 3: SUMMARY OF LIQUEFACTION ANALYSES

Boring Location	Depth To First Liquefiable Zone (ft)	Potential Induced Settlement (in)
CPT-1	44	¼
CPT-2	9.5	1½
CPT-3	10.5	1½
CPT-4	10.5	1¼
B-1	12.5	2

Liquefaction Effects: Based on empirical relationships, total induced settlements are estimated to be about ¼ to 2 inches should liquefaction occur. The minimum differential settlement could be estimated to be on the order of one-half of the total settlement be used in the design. Based on research from Ishihara (1985) and Youd and Garris (1995) ground rupture or sand boil formation is unlikely because of the thickness of the overlying unliquefiable soil. Because of the depth of the liquefiable layer, wide area subsidence from soil overburden would be the expected effect of liquefaction rather than bearing capacity failure of the proposed structures. The relatively high fines content (>30%) within the potentially liquefiable layer will probably reduce pore water movement significantly, thereby stalling development of a "quick" soil condition.

Mitigation: If the differential settlement (about 1 inch) caused by liquefaction is considered excessive, the designer may consider the following ground improvements or foundation designs to mitigate the liquefaction induced settlement.

- 1) Structural flat-plate mats, either conventionally reinforced or tied with post-tensioned tendons.
- 2) Foundations that use grade-beam footings to tie floor slabs and isolated columns to continuous footings (conventional or post-tensioned).
- 3) Deep foundations (drilled piers, geopiers, stone columns or piles) founded at a depth below 45 feet.
- 4) Soil improvement by soil-cement mixing to create non-liquefying soils.

These alternatives reduce the potential effects of liquefaction-induced settlements by making the structures more able to withstand differential settlement. The structural engineer is directed to CDMG Special Publication 117 for design on liquefiable sites.

Section 4

RECOMMENDATIONS

4.1 Site Preparation

Clearing and Grubbing: All surface improvements, debris or vegetation including grass, crop, and weeds on the site at the time of construction should be removed from the construction area. Root structures of the crop may be disced into the soil. Organic strippings should be hauled from the site and not used as fill. **Any trash, construction debris, and buried obstructions such as subsurface tile drainage pipelines exposed during rough grading should be traced to the limits of the foreign material by the grading contractor and removed under our supervision.** Any excavations resulting from site clearing should be dish-shaped to the lowest depth of disturbance and backfilled under the observation of the geotechnical engineer's representative.

The site is underlain by tile drain lines at a depth of approximately 6.0 to 8.0 feet below ground surface (see Appendix A). Tile lines should be cut and plugged at the street crossings. The pipelines are likely full of water and may temporarily flood excavations if not capped promptly. Base lines (8 inch diameter and larger) should be located and crushed in-place with the backfill compacted to a minimum 85 to 90% of ASTM D1557 maximum density.

Building Pad Preparation: The existing surface soil within the office, maintenance shop, and other light buildings foundation areas should be removed to 36 inches below the building pad elevation or existing grade (whichever is lower) extending five feet beyond all exterior wall/column lines (including adjacent concreted areas). Exposed subgrade should be scarified to a depth of 8 inches, uniformly moisture conditioned to 5 to 10% above optimum moisture content and recompacted to 85 to 90% of the maximum density determined in accordance with ASTM D1557 methods.

Heavy Loaded Structures Foundation Subgrade Preparation: For heavy loaded structures designed to be founded on structural mat foundations such as steel storage tanks, site preparation should consist of excavating to the bottom of the proposed foundation elevation (-2.0 to -4.0 feet bgs).

Exposed subgrade should be inspected by the geotechnical engineer and if found to be loose, shall be scarified to a depth of 8 inches, uniformly moisture conditioned to 4 to 8% above optimum and recompacted to a minimum of 90% of the maximum density determined in accordance with ASTM D1557 methods.

Structural Fill Recommendations: The native soil is suitable for use as engineered fill provided it is free from concentrations of organic matter or other deleterious material. The fill soil should be uniformly moisture conditioned by discing and watering to the limits specified above, placed in maximum 8-inch lifts (loose), and compacted to the limits specified above. Clay soil should not be compacted greater than 90% relative compaction because highly compacted soil will result in increased swelling.

If foundation designs are to be utilized for lightly loaded structures which do not include provisions for expansive soil, an engineered building support pad consisting of 3.0 feet of granular soil or lime treated soil, placed in maximum 8-inch lifts (loose), compacted to a minimum of 90% of ASTM D1557 maximum density at 2% below to 4% above optimum moisture, should be placed below the bottom of the slab. Lime content in soil (if used) shall be established by the Eads-Grim Method with a resulting maximum Expansion Index of 15 after lime addition.

Imported fill soil (for foundations designed for expansive soil conditions) should have a Plasticity Index less than 35 and sulfates (SO_4) less than 3,000 ppm. For foundations not designed for expansive soil conditions, non-expansive, granular soil meeting the USCS classifications of SM, SP-SM, or SW-SM with a maximum rock size of 3 inches and 5 to 35% passing the No. 200 sieve shall be used. The geotechnical engineer should approve imported fill soil sources before hauling material to the site. Imported granular fill should be placed in lifts no greater than 8 inches in loose thickness and compacted to a minimum of 95% of ASTM D1557 maximum dry density at optimum moisture $\pm 2\%$.

In areas other than the building pad which are to receive area concrete slabs, the ground surface should be presaturated to a minimum depth of 36 inches and then scarified to 8 inches, moisture conditioned to a minimum of 5% over optimum, and recompacted to 85-90% of ASTM D1557 maximum density just prior to concrete placement.

Trench Backfill: Trench backfill should conform to Regional Standard Drawing S-4, using either Type A, B or C backfill (Appendix D).

Type A backfill for HDPE pipe consists of a 4 to 6 inch bed of ¾-inch crushed rock below the pipe and pipezone backfill (to 12" above top of pipe) that consists of crusher fines (sand). Sewer pipes (SDR-35), water mains, and stormdrain pipes of other than HDPE pipe may use crusher fines for bedding. The crusher fines shall be compacted to a minimum of 90% of ASTM D1557 maximum density. Pipe deflection should be checked to not exceed 2% of pipe diameter. Native clay/silt soils may be used to backfill the remainder of the trench. Clays shall be compacted to a minimum of 85% of ASTM D1557 maximum density and silts shall be compacted to a minimum of 87% of ASTM D1557 maximum density, except that the top 12 inches of the trench shall be compacted to at least 90% of ASTM D1557 maximum density.

Type B backfill for HDPE pipe requires 6 inches of ¾-inch crushed rock as bedding and to springline of the pipe. Thereafter, sand/cement slurry (3 sack cement factor) should be used to 12 inches above the top of the pipe. Native clay and silt soils may be used in the remainder of the trench backfill as specified above.

Type C backfill for HDPE pipe shall consist of a geotextile filter fabric encapsulating ¾-inch crushed rock. The crushed rock thickness shall be 6 inches below and to the sides of the pipe and shall extend to 12 inches above the top of the pipe. The filter fabric shall cover the trench bottom, sidewalls and over the top of the crushed rock. Native clay and silt soils may be used in the remainder of the trench backfill as specified above. **Type C backfill must be used in wet soils and below groundwater for all buried utility pipelines unless dewatered to at least 12 inches below the trench bottom prior to excavation. Type A backfill may be used in the case of a dewatered trench condition.**

On-site soil free of debris, vegetation, and other deleterious matter may be suitable for use as utility trench backfill above pipezone, but may be difficult to uniformly maintain at specified moistures and compact to the specified densities. Native backfill should only be placed and compacted after encapsulating buried pipes with suitable bedding and pipe envelope material.

Imported granular material is acceptable for backfill of utility trenches. Granular trench backfill used in building pad areas should be plugged with a solid (no clods or voids) 2-foot width of native clay soils at each end of the building foundation to prevent landscape water migration into the trench below the building.

Trench backfill soil (native) within paved areas should be placed in layers not more than 6 inches in thickness and mechanically compacted to a minimum of 87% of the ASTM D1557 maximum dry density except for the top 12 inches of the trench which shall be compacted to at least 90%.

Moisture Control and Drainage: The moisture condition of the building pad should be maintained during trenching and utility installation until concrete is placed or should be rewetted before initiating delayed construction. If soil drying is noted, a 2 to 3 inch depth of water may be used in the bottom of footings to restore footing subgrade moisture and reduce potential edge lift. Adequate site drainage is essential to future performance of the project. Infiltration of excess irrigation water and stormwaters can adversely affect the performance of the subsurface soil at the site. Positive drainage should be maintained away from all structures to prevent ponding and subsequent saturation of the native clay soil. If landscape irrigation is allowed next to the building, drip irrigation systems or lined planter boxes should be used. The subgrade soil should be maintained in a moist, but not saturated state, and not allowed to dry out. Drainage should be maintained without ponding.

Observation and Density Testing: All site preparation and fill placement should be continuously observed and tested by a representative of a qualified geotechnical engineering firm. Full-time observation services during the excavation and scarification process is necessary to detect undesirable materials or conditions and soft areas that may be encountered in the construction area. The geotechnical firm that provides observation and testing during construction shall assume the responsibility of "geotechnical engineer of record" and, as such, shall perform additional tests and investigation as necessary to satisfy themselves as to the site conditions and the recommendations for site development.

Auxiliary Structures Foundation Preparation: Auxiliary structures such as free standing or retaining walls should have the existing soil beneath the structure foundation prepared in the manner recommended for the building pad except the preparation needed only to extend 18 inches below and beyond the footing.

4.2 Spread Foundations and Settlements

Shallow spread footings and continuous wall footings are suitable to support the structures associated with the building for offices, maintenance shop, etc. Footings shall be founded on a layer of properly prepared and compacted soil as described in Section 4.1. The foundations may be designed using an allowable soil bearing pressure of 1,500 psf for compacted native clay soil and 2,000 psf when foundations are supported on imported sands (extending a minimum of 1.0 feet below footings). The allowable soil pressure may be increased by 20% for each foot of embedment depth in excess of 18 inches and by one-third for short term loads induced by winds or seismic events. The maximum allowable soil pressure at increased embedment depths shall not exceed 3,000 psf.

To mitigate swelling forces from expansive soils, lightly loaded structures such as office building and control rooms can be designed with grade-beam reinforced foundations or post-tensioned slabs. Recommendations for these are provided below.

Flat Plate Structural Mats: Flat plate structural mats may be used to mitigate expansive soils at the project site. The structural mat shall have a double mat of steel (minimum No. 4's @ 12" O.C. each way – top and bottom) and a minimum thickness of 10 inches. Mat edges shall have a minimum edge footing of 12 inches width and 18 inches depth (below the building pad surface). Mats may be designed by CBC (2007) Chapter 18 Section 1805.8.2 methods using an Effective Plasticity Index of 26.

Structural mats may be designed for a modulus of subgrade reaction (K_s) of 100 pci when placed on compacted clay or a subgrade modulus of 300 pci when placed on 3.0 feet of granular fill. Mats shall overlay 2 inches of sand and a 10-mil polyethylene vapor retarder. The building support pad shall be moisture conditioned and recompacted as specified in Section 4.1 of this report.

Grade-beam Reinforced Foundations: Specific soil data for structures with grade-beam reinforced foundations placed on the native clays (without removal of the surface clay or a minimum of 3.0 feet of underlying granular fill) are presented below in accordance with the design method given in CBC Chapter 18 (2007) Section 1805.8.2 (WRI/CRSI Design of Slab-on-Ground Foundations):

- ▶ Weighted Plasticity Index (PI) = 32
- ▶ Slope Coefficient (C_s) = 1.0
- ▶ Strength Coefficient (C_o) = 0.8
- ▶ Climatic Rating (C_w) = 15
- ▶ Effective PI = 26
- ▶ 1-C Value = 0.13
- ▶ Maximum Grade-beam Spacing = 18 feet

Post-tensioned Slabs: If post-tensioned slabs are considered for this project, the following soil criteria shall be used in the Post Tensioning Institute (PTI, 2004) designs:

Depth to Constant Suction:	5.0 ft.
Constant Suction (pF):	4.2
Maximum Edge Moisture Variation Distance, e_m	Center: 6.7 ft. Edge: 3.4 ft.
Differential Swell, y_m	Center: 0.25 in. Edge: 4.28 in.
Estimated Differential Settlement (swell):	1.0 in.
Bearing Capacity:	1,500 psf
Maximum Allowable Slab Deflection	1 inch

Clamping devices and end anchors for post-tensioned tendons are susceptible to corrosion from aggressive soil and landscape water conditions. Therefore, a minimum concrete cover of 3.0 inches, a PVC end cap and epoxy coatings should be specified for the tendon ends with a positive bonding agent used with polymer modified cementitious material to patch the recessed anchor cup. A complete encapsulation system intended for corrosive environments is a suggested protection method for post-tensioning cables and anchoring/clamping devices.

All exterior foundations should be embedded a minimum of 18 inches below the building support pad or lowest adjacent final grade, whichever is deeper. Embedment depth of interior footings should be a minimum of 12 inches deep. Interior footing embedment depths for post-tensioned foundations shall be determined by the structural engineer/designer and should be sufficient to limit differential movement to 1.0 inch or less. Continuous wall footings should have a minimum width of 12 inches. Spread footings should have a minimum width of 24 inches and should not be structurally isolated (shall be tied with grade beams to structure perimeter or interior footings). Recommended concrete reinforcement and sizing for all footings should be provided by the structural engineer.

Resistance to horizontal loads will be developed by passive earth pressure on the sides of footings and frictional resistance developed along the bases of footings and concrete slabs. Passive resistance to lateral earth pressure may be calculated using an equivalent fluid pressure of 250 pcf (300 pcf for sands) to resist lateral loadings. The top one foot of embedment should not be considered in computing passive resistance unless the adjacent area is confined by a slab or pavement. An allowable friction coefficient of 0.25 (0.35 for sands) may also be used at the base of the footings to resist lateral loading.

Foundation movement under the estimated static (non-seismic) loadings and static site conditions are estimated to not exceed $\frac{3}{4}$ inch with differential movement of about two-thirds of total movement for the loading assumptions stated above when the subgrade preparation guidelines given above are followed. Seismically induced liquefaction settlement may be on the order of 1 to 2 inches.

Structural Mat Foundations for Heavy Structures: Structural concrete mat foundations are suitable to support the proposed above ground steel storage tanks. The mat shall be founded on the native clays or a layer of properly prepared and compacted soil as described in the Site Preparation Section. The foundations may be designed using an allowable soil bearing pressure of 1,500 psf at 2.0 foot depth into native clay soils. The allowable soil pressure may be increased by 20% for each foot of embedment depth in excess of 24 inches and by one-third for short term loads induced by winds or seismic events. The maximum allowable soil pressure at increased embedment depths shall not exceed 4,000 psf.

Structural mats may be designed for a modulus of subgrade reaction (Ks) of 100 pci when placed on compacted native clay. The structure support pad shall consist of stiff native clay or shall be moisture conditioned and recompacted as specified in the Site Preparation Section of this Report.

Resistance to horizontal loads will be developed by passive earth pressure on the sides of footings and frictional resistance developed along the bases of footings and concrete slabs. Passive resistance to lateral earth pressure may be calculated using an equivalent fluid pressure of 250 pcf to resist lateral loadings. The top one foot of embedment should not be considered in computing passive resistance unless the adjacent area is confined by a slab or pavement. An allowable friction coefficient of 0.30 may also be used at the base of the structural mat to resist lateral loading.

Settlement estimates (in inches) developed for different footing and mat dimensions embedded a minimum of 2.0 feet into native soils and loaded to 1000, 2,000, 3,000 and 4,000 psf follow:

Table 4: Settlement Estimates (inches)

Load, psf	Size of Footing or Mat (ft.)					
	5 x 5	10 x 10	15 x 15	20 x 20	25 x 25	30 x 30
1,000	0.6	1.0	1.3	1.6	1.8	2.0
2,000	1.0	1.7	2.2	2.7	3.1	3.4
3,000	1.3	2.3	3.0	3.6	4.1	4.6
4,000	1.6	2.8	3.6	4.4	5.1	5.7

4.3 Steel Tank Foundations and Settlements

Site Preparation and Grading: The existing soils underlying the steel storage tanks should be removed to a depth of 36 inches below ground surface extending to a minimum of 5 feet beyond the perimeter of the tanks. The surface 8 inches of native soil exposed at the subexcavation and footing excavation level should be compacted to 85 - 90 % of ASTM D1557 maximum density at 5 to 10% above optimum moisture.

The area should then be brought to finish grade with engineered fill consisting of the following components:

- 24 inches of crushed aggregate base
- 8 inches of crushed rock
- 4 inches of oiled sand

As a minimum, a steel ring should be placed to contain the crushed rock subgrade below the tank. The rock fill should be placed to the top of the ring wall. The fill may be crowned about 40% of the total center settlement to allow for differential settlement between the tank perimeter and center.

The engineered fill should be placed in 8-inch maximum loose lifts and compacted to a minimum 95% of ASTM D1557 maximum density within 2% of optimum moisture. The crushed rock tank underlayment should meet the gradation requirements of ASTM C33, size 57 (1" x No. 4 rock). The proposed source of engineered fill and rock should be submitted to the geotechnical engineer for review and testing to verify conformance to these requirements.

Tank Foundations: Flexible steel tanks, which can withstand large settlements, generally require minimal foundations, allowing settlement to occur and using flexible connections to inlet/outlet piping. The tanks should have a perimeter ring wall foundation which supports the tank wall and roof.

The interior footings and the ringwall may be proportioned for a net load of 1,500 to 2,000 psf for roof dead load (plus sustained live load) excluding the weight of the liquid fertilizer. This soil pressure can be increased by one third for transient and seismic loads. The minimum depth of the ring wall footing should be 18 inches below the finished ground surface. The minimum footing width should be 12 inches.

Estimated Tank Settlements: The subsurface clays are saturated and overconsolidated in their natural state. Imposed foundation loads can consolidate the soils by reducing the void ratio through pore water expulsion. The amount of vertical settlement that occurs as a result of soil compression varies with applied loads, foundation shape and width.

Moderately loaded structures, such as the flexible steel tanks which can withstand large settlements, will generally require minimal foundations, allowing settlement to occur and using flexible connections to inlet/outlet utility lines. The silts and clays will consolidate fairly slowly because of their low permeability. Flexible connections such as a "Flex-Tend" expansion joints should be used to connect exterior piping with the tank. The tank should be preloaded and monitored for settlement prior to making piping connections. It may be necessary to readjust piping connections after the loading sequence.

Estimated settlements were calculated using the consolidation and field data test data for the silt and clay strata and Schmertman's analysis for the granular strata using the CPT engineering properties correlations. The soils to a depth of the diameter of the tanks (20 to 100 feet) may be significantly stressed so as to contribute to the overall settlement. The estimated settlements for different tanks heights and diameters are provided in the table below:

Table 5: Estimated Center Settlements of Tanks

Height, ft	Diameter (ft)				
	20	40	60	80	100
20	2.5"	4.0"	4.7"	5.1"	5.4"
24	2.8"	4.4"	5.2"	5.7"	5.9"
28	3.1"	4.9"	5.9"	6.4"	6.7"
36	3.6"	5.8"	6.9"	7.4"	7.8"
50	4.5'	7.1"	8.4"	9.1"	9.5"
60	5.0"	8.0"	9.4"	10.2"	10.6"
70	5.5"	8.7"	10.2"	11.0"	11.6"

The estimated settlements for the tanks are approximately 2.5 to 11.6 inches in the center of the tanks and about 1.0 to 4.9 inches at the edge of the tanks (depending on tank dimensions). Since the settlement is deep seated, little is gained by further excavation and replacement of compacted granular fill to reduce settlements. Ground improvement methods (geopiers, soil-cement mixing, etc.) are may be considered to reduce settlements.

4.4 Slabs-On-Grade

Concrete slabs and flatwork placed over native clay soil should be designed in accordance with Chapter 18 of the 2007 CBC (using an Effective Plasticity Index of 26) and shall be a minimum of 5 inches thick due to expansive soil conditions. Concrete floor slabs shall be monolithically placed with the foundations unless placed on 3.0 feet of granular fill or lime treated soil. The concrete slabs should be underlain by a minimum of 4 inches of clean sand (Sand Equivalent SE>30) or aggregate base or may be placed directly on the 3.0-foot thick granular fill pad (if used) that has been moistened to approximately optimum moisture just before the concrete placement. A 10-mil polyethylene vapor retarder, properly lapped and sealed with a 2-inch sand cover and extended a minimum of 12 inches into the footing, should be placed as a capillary break to inhibit moisture migration into the slab section. Concrete slabs may be placed directly over a 15-mil vapor retarder if desired (Stego-Wrap or equivalent).

Concrete slab and flatwork reinforcement should consist of chaired rebar slab reinforcement (minimum of No. 4 bars at 18-inch centers, both horizontal directions) placed at slab mid-height to resist potential swell forces and cracking. Slab thickness and steel reinforcement are minimums only and should be verified by the structural engineer/designer knowing the actual project loadings. All steel components of the foundation system should be protected from corrosion by maintaining a 3-inch minimum concrete cover of densely consolidated concrete at footings (by use of a vibrator).

The construction joint between the foundation and any mowstrips/sidewalks placed adjacent to foundations should be sealed with a polyurethane based non-hardening sealant to prevent moisture migration between the joint. Epoxy coated embedded steel components or permanent waterproofing membranes placed at the exterior footing sidewall may also be used to mitigate the corrosion potential of concrete placed in contact with native soil.

Control joints should be provided in all concrete slabs-on-grade at a maximum spacing (in feet) of 2 to 3 times the slab thickness (in inches) as recommended by American Concrete Institute (ACI) guidelines. All joints should form approximately square patterns to reduce randomly oriented contraction cracks. Contraction joints in the slabs should be tooled at the time of the pour or sawcut ($\frac{1}{4}$ of slab depth) within 6 to 8 hours of concrete placement.

Construction (cold) joints in foundations and area flatwork should either be thickened butt-joints with dowels or a thickened keyed-joint designed to resist vertical deflection at the joint. All joints in flatwork should be sealed to prevent moisture, vermin, or foreign material intrusion. Precautions should be taken to prevent curling of slabs in this arid desert region (refer to ACI guidelines).

All independent flatwork (sidewalks, housekeeping slabs) should be placed on a minimum of 2 inches of concrete sand or aggregate base, dowelled to the perimeter foundations where adjacent to the building and sloped 2% or more away from the building. A minimum of 24 inches of moisture conditioned (20% moisture content) and 8 inches of compacted subgrade (83 to 87%) and a 10-mil (minimum) polyethylene separation sheet should underlie the flatwork. All flatwork should be jointed in square patterns and at irregularities in shape at a maximum spacing of 10 feet or the least width of the sidewalk.

4.5 Concrete Mixes and Corrosivity

Selected chemical analyses for corrosivity were conducted on bulk samples of the near surface soil from the project site (Plate C-3). The native soils were found to have low to severe levels of sulfate ion concentration (848 to 3,831 ppm). Sulfate ions in high concentrations can attack the cementitious material in concrete, causing weakening of the cement matrix and eventual deterioration by raveling.

The California Building Code recommends that increased quantities of Type II Portland Cement be used at a low water/cement ratio when concrete is subjected to moderate sulfate concentrations. Type V Portland Cement and/or Type II/V cement with 25% flyash replacement is recommended when the concrete is subjected to soil with severe sulfate concentration.

A minimum of 6.0 sacks per cubic yard of concrete (4,500 psi) of Type V Portland Cement with a maximum water/cement ratio of 0.45 (by weight) should be used for concrete placed in contact with native soil on this project (sitework including sidewalks, driveways, and foundations). Admixtures may be required to allow placement of this low water/cement ratio concrete.

The native soil has a severe to very severe level of chloride ion concentration (720 to 4,480 ppm). Chloride ions can cause corrosion of reinforcing steel, anchor bolts and other buried metallic conduits. Resistivity determinations on the soil indicate very severe potential for metal loss because of electrochemical corrosion processes. Mitigation of the corrosion of steel can be achieved by using steel pipes coated with epoxy corrosion inhibitors, asphaltic and epoxy coatings, cathodic protection or by encapsulating the portion of the pipe lying above groundwater with a minimum of 3 inches of densely consolidated concrete. *No metallic pipes or conduits should be placed below foundations.*

Foundation designs shall provide a minimum concrete cover of three (3) inches around steel reinforcing or embedded components (anchor bolts, etc.) exposed to native soil or landscape water (to 18 inches above grade). If the 3-inch concrete edge distance cannot be achieved, all embedded steel components (anchor bolts, etc.) shall be epoxy dipped for corrosion protection or a corrosion inhibitor and a permanent waterproofing membrane shall be placed along the exterior face of the exterior footings. Additionally, the concrete should be thoroughly vibrated at footings during placement to decrease the permeability of the concrete.

4.6 Excavations

All site excavations should conform to CalOSHA requirements for Type B soil. The contractor is solely responsible for the safety of workers entering trenches. Temporary excavations with depths of 4 feet or less may be cut nearly vertical for short duration. Excavations deeper than 4 feet will require shoring or slope inclinations in conformance to CAL/OSHA regulations for Type B soil. Surcharge loads of stockpiled soil or construction materials should be set back from the top of the slope a minimum distance equal to the height of the slope. All permanent slopes should not be steeper than 3:1 to reduce wind and rain erosion. Protected slopes with ground cover may be as steep as 2:1. However, maintenance with motorized equipment may not be possible at this inclination.

4.7 Lateral Earth Pressures

Earth retaining structures, such as retaining walls, should be designed to resist the soil pressure imposed by the retained soil mass. Walls with granular drained backfill may be designed for an assumed static earth pressure equivalent to that exerted by a fluid weighing 55 pcf for unrestrained (active) conditions (able to rotate 0.1% of wall height), and 70 pcf for restrained (at-rest) conditions. These values should be verified at the actual wall locations during construction.

When applicable (walls retaining more than 6 feet of earth) seismic earth pressure on walls may be assumed to exert a uniform pressure distribution of $7.5H$ psf against the back of the wall, where H is the height of the backfill. The total seismic load is assumed to act as a point load at $0.6H$ above the base of the wall.

Surcharge loads should be considered if loads are applied within a zone between the face of the wall and a plane projected behind the wall 45 degrees upward from the base of the wall. The increase in lateral earth pressure acting uniformly against the back of the wall should be taken as 50% of the surcharge load within this zone. Areas of the retaining wall subjected to traffic loads should be designed for a uniform surcharge load equivalent to two feet of native soil.

Walls should be provided with backdrains to reduce the potential for the buildup of hydrostatic pressure. The drainage system should consist of a composite HDPE drainage panel or a 2-foot wide zone of free draining crushed rock placed adjacent to the wall and extending $2/3$ the height of the wall. The gravel should be completely enclosed in an approved filter fabric to separate the gravel and backfill soil. A perforated pipe should be placed perforations down at the base of the permeable material at least six inches below finished floor elevations. The pipe should be sloped to drain to an appropriate outlet that is protected against erosion. Walls should be properly waterproofed. The project geotechnical engineer should approve any alternative drain system.

4.8 Seismic Design

This site is located in the seismically active southern California area and the site structures are subject to strong ground shaking due to future fault movements along the nearby Imperial Fault (0.6 miles east of the project site). Engineered design and earthquake-resistant construction are the common solutions to increase safety and development of seismic areas. Designs should comply with the latest edition of the CBC for Seismic Zone 4 using the seismic coefficients given in Section 3.4 of this report. *This site lies approximately 1.9 km from a Type A fault and overlies S_b (stiff) soil.*

4.9 Pavements

Pavements should be designed according to CALTRANS or other acceptable methods. Traffic indices were not provided by the project engineer or owner; therefore, we have provided structural sections for several traffic indices for comparative evaluation. The public agency or design engineer should decide the appropriate traffic index for the site. Maintenance of proper drainage is necessary to prolong the service life of the pavements.

Based on the current State of California CALTRANS method, and R-value of 5 for the subgrade soil and assumed traffic indices, the following table provides our estimates for asphaltic concrete (AC) pavement sections.

Table 6: Recommended Pavement Structural Sections

R-Value of Subgrade Soil - 5 Design Method - CALTRANS 2006

Traffic Index (assumed)	Flexible Pavements		(*) Flexible Pavements		Rigid (PCC) Pavements	
	Asphaltic Concrete Thickness (in.)	Aggregate Base Thickness (in.)	Asphaltic Concrete Thickness (in.)	Aggregate Base Thickness (in.)	Concrete Thickness (in.)	Aggregate Base Thickness (in.)
4.0	3.0	8.0	3.0	4.0	5.0	6.0
5.0	3.0	9.0	3.0	4.0	5.5	6.0
6.0	3.0	14.0	3.0	6.0	6.0	6.0
6.5	4.0	14.0	4.0	8.0	7.0	8.0
8.0	4.0	18.0	4.0	11.0	8.0	11.0
10.0	4.5	26.0	4.5	16.0	9.0	13.0
11.0	5.5	28.0	5.5	20.0	10.0	15.0

(*) Pavement structural section when used in conjunction with lime-treated subgrade soil (3-6% quicklime by weight) with minimum Unconfined Compressive Strength of 55 psi.

Notes:

- 1) Asphaltic concrete shall be Caltrans, Type B, ¾ inch maximum (½ inch maximum for parking areas), medium grading, compacted to a minimum of 95% of the 75-blow Marshall density (ASTM D1559) or Hveem Density (Cal 366).
- 2) Aggregate base shall conform to Caltrans Class 2 (¾ in. maximum), compacted to a minimum of 95% of ASTM D1557 maximum dry density.
- 3) Place pavements on 12 inches of moisture conditioned (minimum 4% above optimum if clays) native clay soil compacted to a minimum of 90% (95% if sand subgrade) of the maximum dry density determined by ASTM D1557.
- 4) Portland cement concrete for pavements should have Type V cement, a minimum compressive strength of 4,500 psi at 28 days, and a maximum water-cement ratio of 0.45.
- 5) Typical Street Classifications (Imperial County)
 - Cul-de-Sacs: TI = 5.0
 - Local Streets: TI = 6.0
 - Minor Collectors: TI = 6.5
 - Major Collectors: TI = 8.0
 - Minor Arterial: TI = 10.0
 - Primary Arterial: TI = 11.0

4.10 Railroad Spur Line Subgrade Preparation

Option No. 1:

The site preparation for the railroad spur line will consist of the removal of 1.5 feet of native soil (17.33 feet wide) along the spur route. The exposed subgrade soil will be scarified and compacted to a minimum of 90% of ASTM D1557 maximum density at a minimum of 4% above optimum moisture and a geotextile fabric placed over the subgrade as specified below.

Option No. 2:

If it is desired that an “above grade” ballast and sub-ballast be used, the surface 1.5 feet of native soil shall be removed to a width of 23.33 feet and recompactd to at least 90% (ASTM D1557) at a minimum of 4% above optimum moisture. A geotextile stabilization/separation fabric such as Mirafi “Geolon HP 370” or equivalent should be placed over the prepared native clay subgrade prior to placing sub-ballast.

An 18-inch layer of Caltrans Class 2 Aggregate Base (1½ inch grading) material shall be placed as sub-ballast and compacted in 6-inch lifts over the geotextile fabric. If placed above grade, the sub-ballast should be 23.33 feet wide and extend upward with 2:1 outer slopes to a top width of 17.33 feet wide. If no geotextile is used, an additional 6 inches of class 2 aggregate base should be used. The Class 2 base shall be moisture conditioned (\pm 2% of optimum moisture) and compacted to a minimum of 95% of ASTM D1557 maximum density.

After sub-ballast placement, a minimum of 8 inches of railroad ballast shall be placed below the railroad ties. The ballast shall be sloped no steeper than 3:1 giving a 13.33-foot wide surface to support the rail ties.

Section 5
LIMITATIONS AND ADDITIONAL SERVICES

5.1 Limitations

The recommendations and conclusions within this report are based on current information regarding the proposed JR Simplot Fertilizer Terminal facility relocation located north of Harris Road along the west side of the Union Pacific Railroad tracks north of Imperial, California. The conclusions and recommendations of this report are invalid if:

- ▶ Structural loads change from those stated or the structures are relocated.
- ▶ The Additional Services section of this report is not followed.
- ▶ This report is used for adjacent or other property.
- ▶ Changes of grade or groundwater occur between the issuance of this report and construction other than those anticipated in this report.
- ▶ Any other change that materially alters the project from that proposed at the time this report was prepared.

Findings and recommendations in this report are based on selected points of field exploration, geologic literature, laboratory testing, and our understanding of the proposed project. Our analysis of data and recommendations presented herein are based on the assumption that soil conditions do not vary significantly from those found at specific exploratory locations. Variations in soil conditions can exist between and beyond the exploration points or groundwater elevations may change. If detected, these conditions may require additional studies, consultation, and possible design revisions.

This report contains information that may be useful in the preparation of contract specifications. However, the report is not worded in such a manner that we recommend its use as a construction specification document without proper modification. The use of information contained in this report for bidding purposes should be done at the contractor's option and risk.

This report was prepared according to the generally accepted *geotechnical engineering standards of practice* that existed in Imperial County at the time the report was prepared. No express or implied warranties are made in connection with our services. This report should be considered invalid for periods after two years from the report date without a review of the validity of the findings and recommendations by our firm, because of potential changes in the Geotechnical Engineering Standards of Practice.

The client has responsibility to see that all parties to the project including, designer, contractor, and subcontractor are made aware of this entire report. The use of information contained in this report for bidding purposes should be done at the contractor's option and risk.

5.2 Additional Services

We recommend that Landmark Consultants, Inc. be retained as the geotechnical consultant to provide the tests and observations services during construction. If Landmark Consultants does not provide such services then *the geotechnical engineering firm providing such tests and observations shall become the geotechnical engineer of record and assume responsibility for the project.*

The recommendations presented in this report are based on the assumption that:

- ▶ Consultation during development of design and construction documents to check that the geotechnical recommendations are appropriate for the proposed project and that the geotechnical recommendations are properly interpreted and incorporated into the documents.
- ▶ Landmark Consultants will have the opportunity to review and comment on the plans and specifications for the project prior to the issuance of such for bidding.
- ▶ Continuous observation, inspection, and testing by the geotechnical consultant of record during site clearing, grading, excavation, placement of fills, building pad and subgrade preparation, and backfilling of utility trenches.
- ▶ Observation of foundation excavations and reinforcing steel before concrete placement.
- ▶ Other consultation as necessary during design and construction.

We emphasize our review of the project plans and specifications to check for compatibility with our recommendations and conclusions. Additional information concerning the scope and cost of these services can be obtained from our office.

APPENDIX A

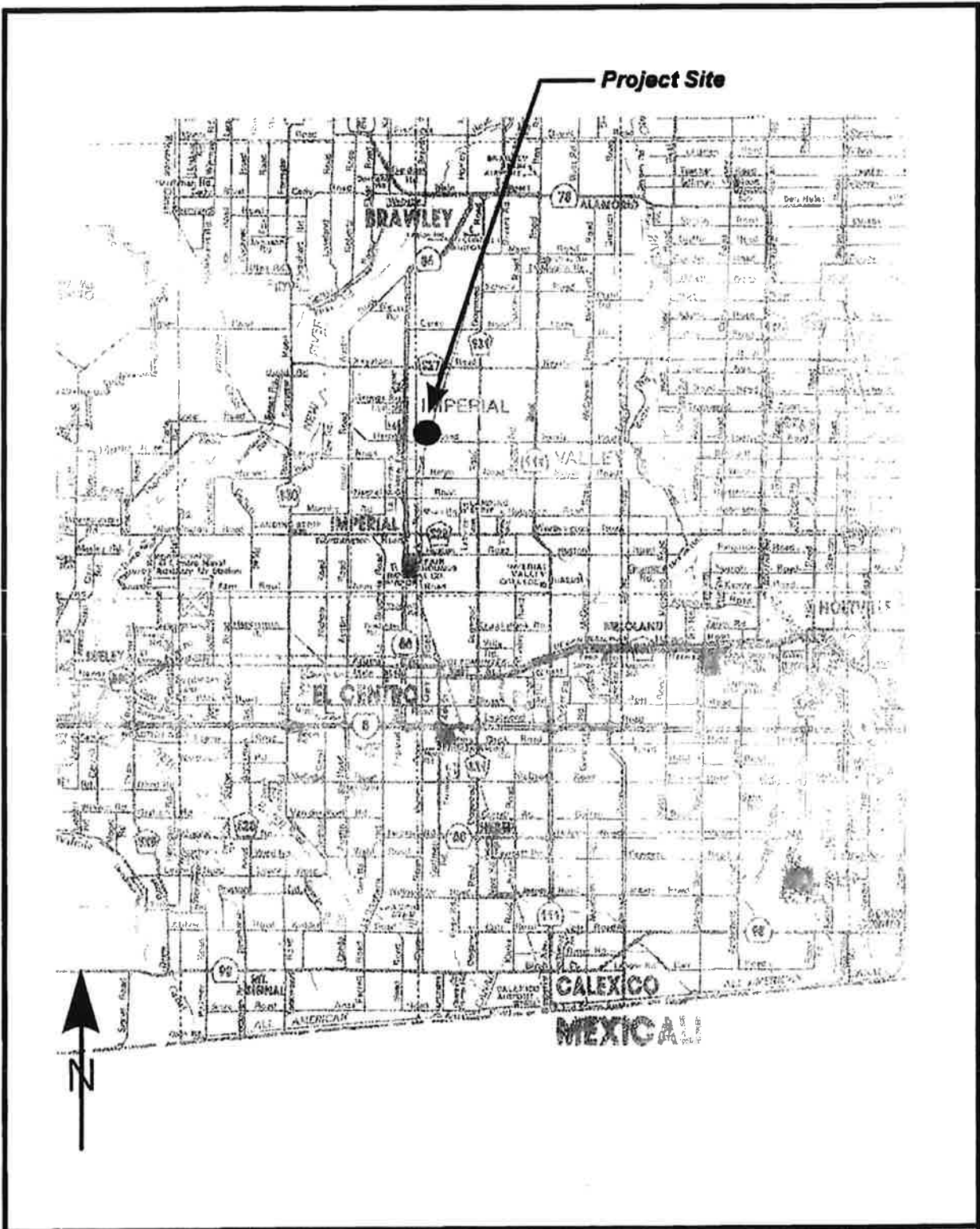

LANDMARK
Geo Engineers and Geologists

Project No.: LE07435

Vicinity Map

Plate
A-1

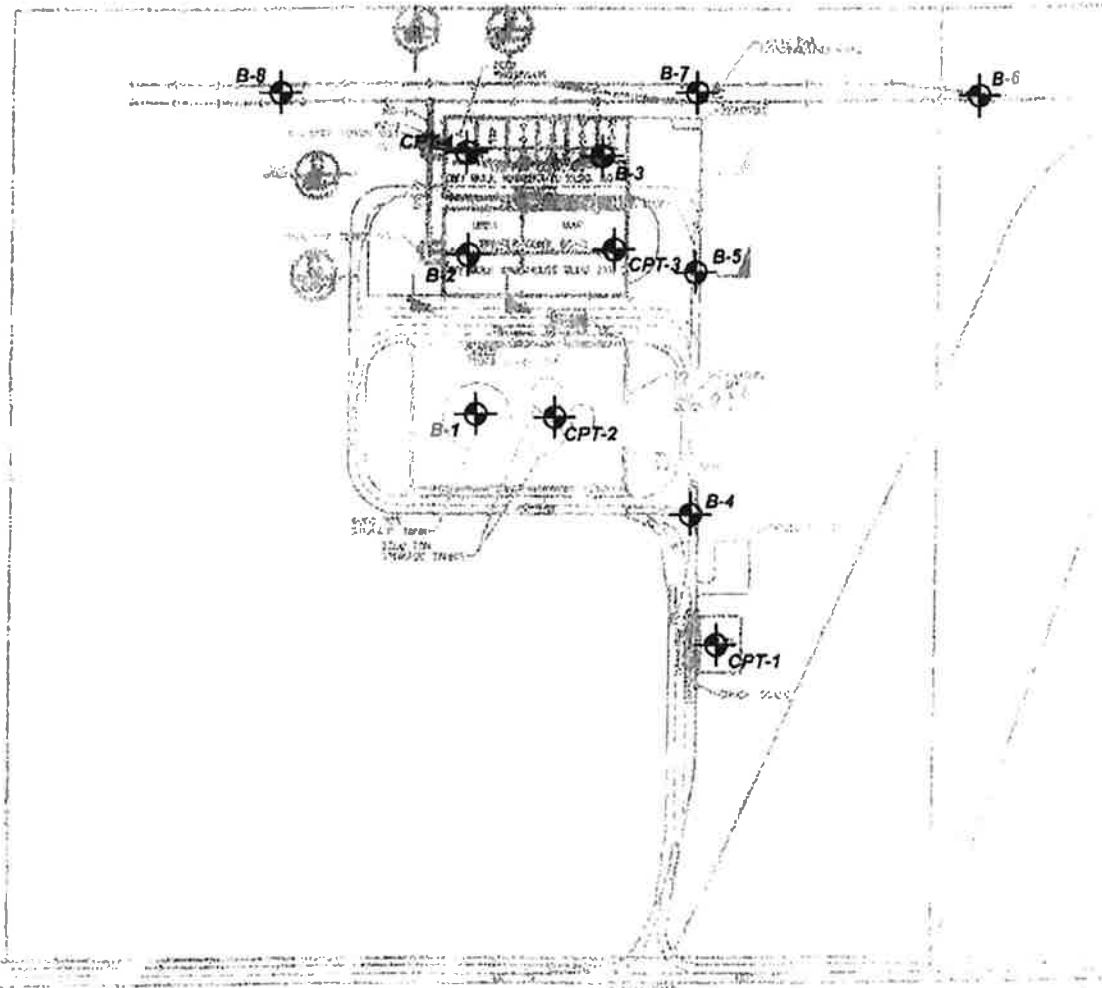

LANDMARK
Geo Engineering and Geologists
Project No.: LE07435

Site and Exploration Map

**Plate
A-2**

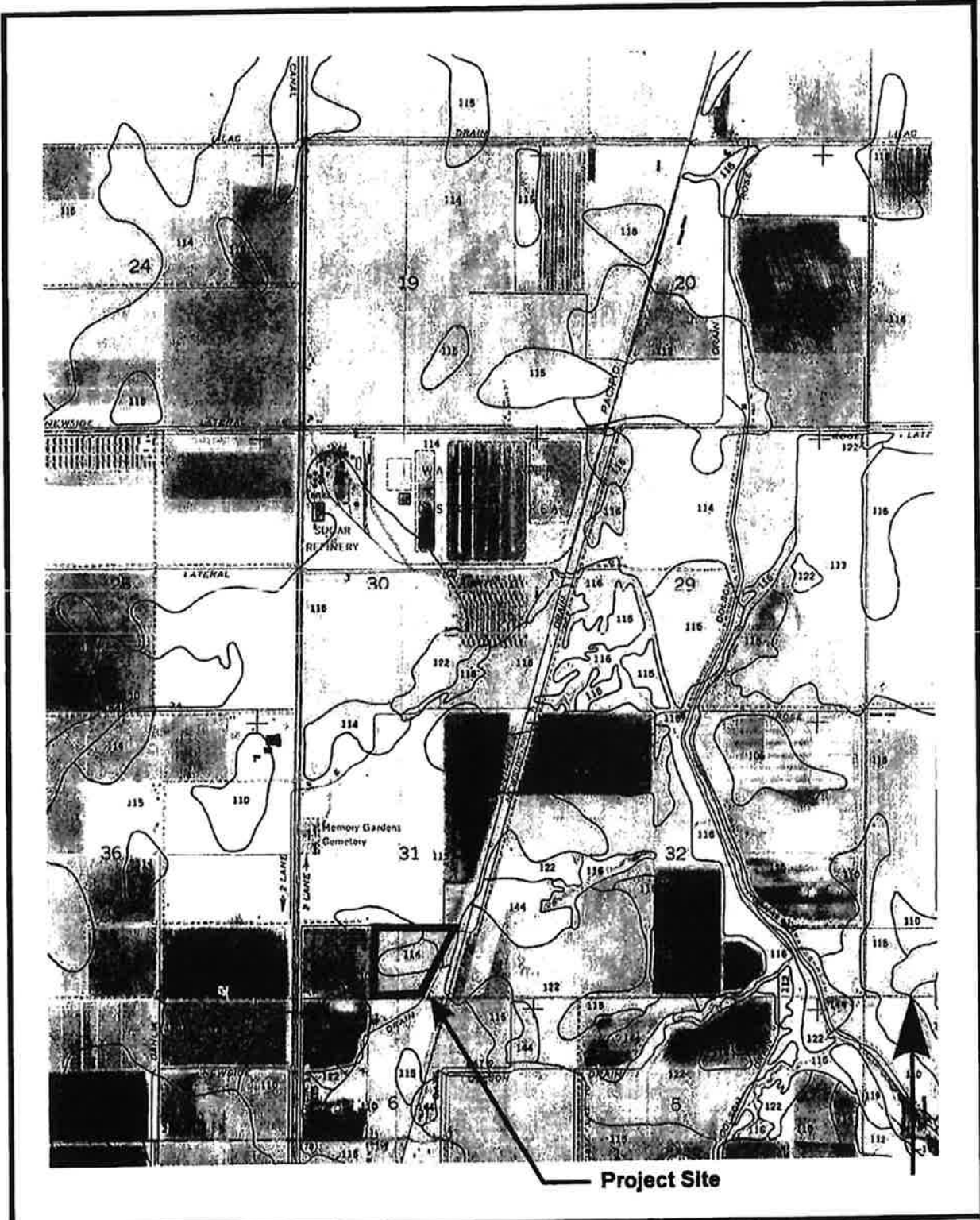

LANDMARK
 two Engrs. and Geologists
 Project No.: LE07435

Soil Survey Map

**Plate
 A-3**

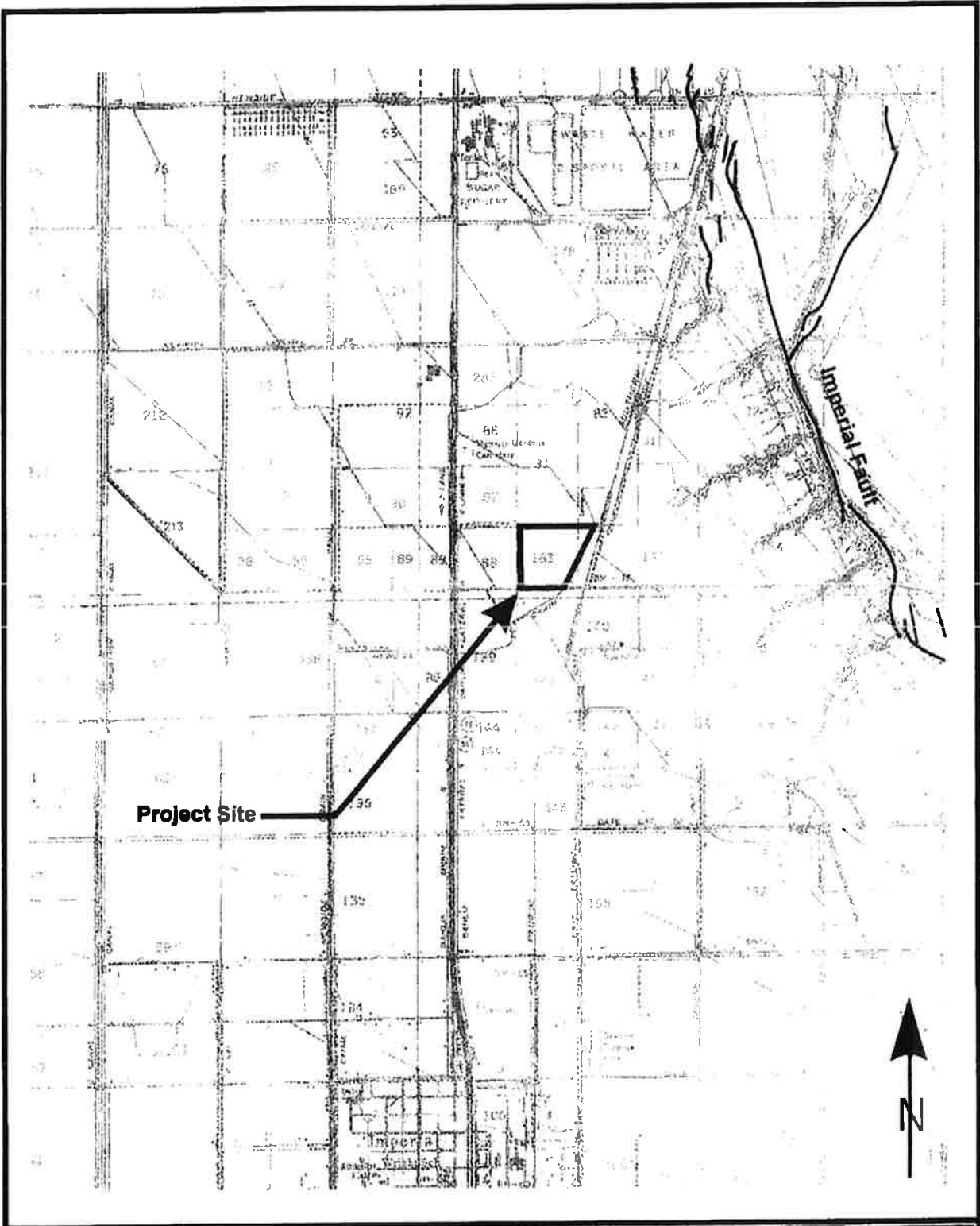

LANDMARK
Civil Engineering and Surveying

Project No.: LE07435

A-P Earthquake Fault Hazard Map

Plate

A-5

TD-3642-1

LINE NO.	INLET ELEV.	NAME	MAX. DEPTH STA AND 100' ILE	OUTLET STA. POINT	STIMMED FOOTAGE	TILE INSTALLED	
						3"	4"
1		007		7.0			
4				3+10 #1	1295		14/9
6				5+21 #1	1189		
8				7+45 #1	1103		
9				8+54 #1	1055		
10				9+65 #1	1007		
12				11+80 #1	911		
14				13+97 #1	815		

IMPERIAL IRRIGATION DISTRICT
ENGINEERING DEPARTMENT
IMPERIAL, CALIFORNIA

TILE DRAIN CONSTRUCTION
PT. TR. 183

PROF. NECKEL
SCALE: 1" = 400'

TD-3642

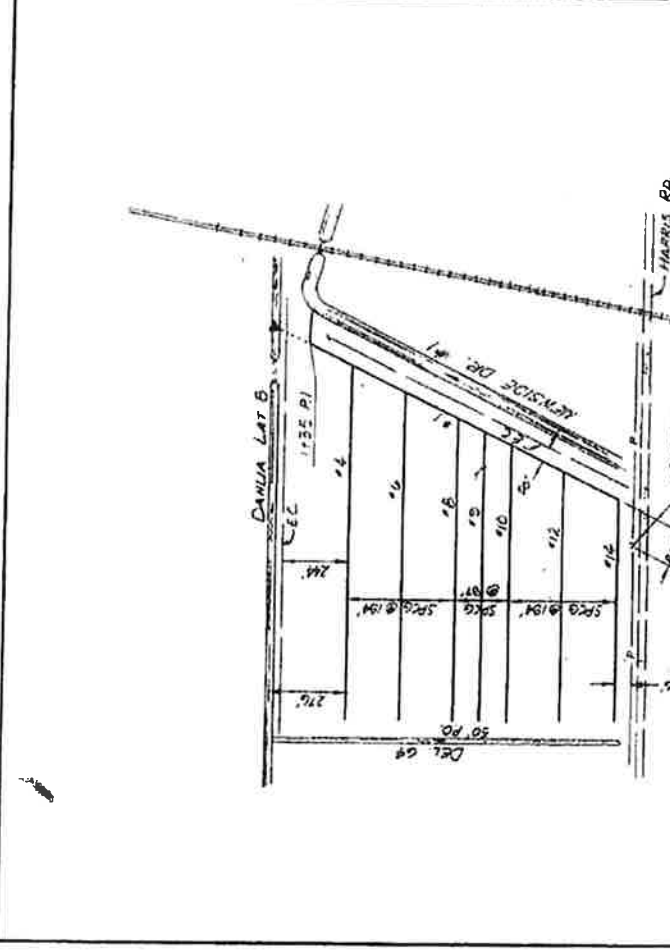

REVISION	DATE	BY	REASON
ISSUE 1			CONSTR STKS 1073-83 ADJ
ISSUE 2			
ISSUE 3			
ISSUE 4			

STANDARD 7-25-83 BY KEN SKILLMAN
INSTALL 8-5-83 BY LLOYD
MATERIAL NEST MESA ULS PLASTIC
PARTIC AJO CHECKED FWH

APPENDIX B

CLIENT: DD&E
 PROJECT: JR Simplot Fertilizer Terminal -- Imperial, CA
 LOCATION: See Site and Boring Location Plan

CONE PENETROMETER: Middle Earth Geotesting, Inc. Truck Mounted Electric
 Cone with 23 ton reaction weight

DATE: 11/19/07

LOG OF CONE SOUNDING DATA CPT-1

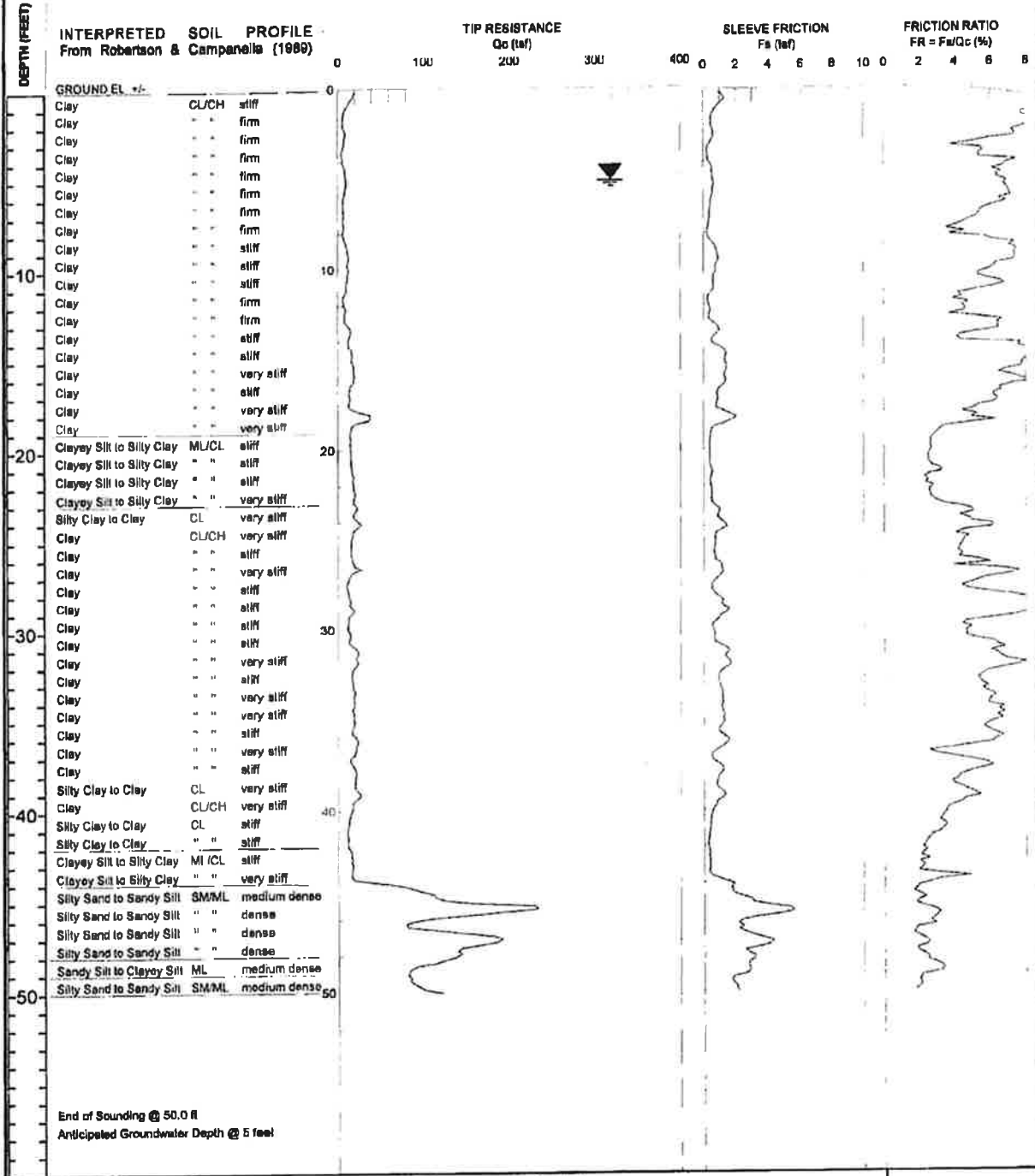

Project No:
LE07435



Plate
B-1

LANDMARK CONSULTANTS, INC.

CONE PENETROMETER INTERPRETATION (based on Robertson & Campanella, 1989, refer to Key to CPT logs)

Project: JR Simplot Fertilizer Terminal
CONE SOUNDING: CPT-1

Project No: LE07435

Date: 11/19/07

Est. GWT (ft)		5.0																	
Base Depth	Base Tip	Avg Friction	Avg Friction	Soil Type	Soil Classification	USC	Density or Consistency	Est. Density (pcf)	Qc N	Cn N(60)	Phi Correlation or Norm. Cq	Est. Rel. % Fines	Rel. Den. Dr (%)	Nk (deg.)	Phi	Su (tsf)	OCR		
0.15	0.5	17.95	8.28	3	Clay	CL/CH	very stiff	125	1.3	14	2.00	95				1.08	>10		
0.30	1.0	11.95	8.43	3	Clay	CL/CH	stiff	125	1.3	10	2.00	100				0.70	>10		
0.45	1.5	8.84	8.38	3	Clay	CL/CH	firm	125	1.3	8	2.00	100				0.40	>10		
0.60	2.0	5.78	8.14	3	Clay	CL/CH	firm	125	1.3	5	2.00	100				0.33	>10		
0.75	2.5	7.51	7.80	3	Clay	CL/CH	firm	125	1.3	6	2.00	100				0.43	>10		
0.93	3.0	7.62	6.84	3	Clay	CL/CH	firm	125	1.3	8	2.00	100				0.44	>10		
1.08	3.5	5.74	4.76	3	Clay	CL/CH	firm	125	1.3	5	2.00	100				0.33	>10		
1.23	4.0	4.87	5.44	3	Clay	CL/CH	firm	125	1.3	4	2.00	100				0.28	8.27		
1.38	4.5	6.95	7.03	3	Clay	CL/CH	firm	125	1.3	8	2.00	100				0.38	>10		
1.53	5.0	8.89	6.37	3	Clay	CL/CH	firm	125	1.3	7	1.89	100				0.49	>10		
1.68	5.5	9.15	6.75	3	Clay	CL/CH	stiff	125	1.3	7	1.84	100				0.52	>10		
1.83	6.0	7.54	7.07	3	Clay	CL/CH	firm	125	1.3	8	1.80	100				0.42	9.59		
1.98	6.5	8.49	6.55	3	Clay	CL/CH	firm	125	1.3	5	1.75	100				0.36	6.65		
2.13	7.0	8.75	5.54	3	Clay	CL/CH	firm	125	1.3	5	1.72	100				0.38	6.65		
2.28	7.5	6.73	4.88	3	Clay	CL/CH	firm	125	1.3	5	1.68	100				0.37	6.21		
2.45	8.0	6.38	4.06	3	Clay	CL/CH	firm	125	1.3	5	1.65	100				0.35	5.31		
2.60	8.5	7.73	5.17	3	Clay	CL/CH	firm	125	1.3	6	1.61	100				0.43	6.76		
2.75	9.0	10.47	7.29	3	Clay	CL/CH	stiff	125	1.3	8	1.58	100				0.59	>10		
2.90	9.5	12.26	7.37	3	Clay	CL/CH	stiff	125	1.3	10	1.55	100				0.70	>10		
3.05	10.0	11.45	6.80	3	Clay	CL/CH	stiff	125	1.3	9	1.63	100				0.65	>10		
3.20	10.5	11.49	5.97	3	Clay	CL/CH	stiff	125	1.3	9	1.50	100				0.65	>10		
3.35	11.0	9.84	6.35	3	Clay	CL/CH	stiff	125	1.3	8	1.48	100				0.55	7.58		
3.50	11.5	8.31	5.13	3	Clay	CL/CH	firm	125	1.3	7	1.45	100				0.48	6.42		
3.65	12.0	6.44	4.37	3	Clay	CL/CH	firm	125	1.3	6	1.43	100				0.35	3.50		
3.80	12.5	8.53	4.54	3	Clay	CL/CH	firm	125	1.3	7	1.41	100				0.47	5.10		
3.95	13.0	8.02	5.17	3	Clay	CL/CH	firm	125	1.3	6	1.38	100				0.44	4.47		
4.13	13.5	14.04	6.45	3	Clay	CL/CH	stiff	125	1.3	11	1.37	100				0.79	>10		
4.28	14.0	13.10	4.86	3	Clay	CL/CH	stiff	125	1.3	10	1.35	100				0.74	9.39		
4.43	14.5	13.82	6.53	3	Clay	CL/CH	stiff	125	1.3	11	1.33	100				0.77	9.69		
4.58	15.0	18.37	8.38	3	Clay	CL/CH	stiff	125	1.3	13	1.32	100				0.83	>10		
4.73	15.5	17.28	7.84	3	Clay	CL/CH	stiff	125	1.3	14	1.30	100				0.98	>10		
4.88	16.0	18.82	7.10	3	Clay	CL/CH	very stiff	125	1.3	15	1.28	100				1.07	>10		
5.03	16.5	15.68	7.77	3	Clay	CL/CH	stiff	125	1.3	12	1.27	100				0.88	>10		
5.18	17.0	13.30	6.44	3	Clay	CL/CH	stiff	125	1.3	11	1.25	100				0.74	7.27		
5.33	17.5	13.24	6.31	3	Clay	CL/CH	stiff	125	1.3	11	1.24	100				0.74	6.88		
5.48	18.0	25.85	4.87	3	Clay	CL/CH	very stiff	125	1.3	21	1.23	90				1.48	>10		
5.65	18.5	31.88	5.63	3	Clay	CL/CH	very stiff	125	1.3	25	1.21	85				1.82	>10		
5.80	19.0	15.18	3.77	4	Silty Clay to Clay	CL	stiff	125	1.8	9	1.20	100				0.85	>10		
5.95	19.5	14.50	2.82	5	Clayey Silt to Silty Clay	ML/CL	stiff	120	2.5	6	1.19	100				0.81	>10		
6.10	20.0	14.60	2.84	5	Clayey Silt to Silty Clay	ML/CL	stiff	120	2.5	6	1.18	95				0.81	>10		
6.25	20.5	15.28	2.58	5	Clayey Silt to Silty Clay	ML/CL	stiff	120	2.5	6	1.17	95				0.85	>10		
6.40	21.0	15.70	2.59	5	Clayey Silt to Silty Clay	ML/CL	stiff	120	2.5	6	1.16	95				0.88	>10		
6.55	21.5	17.44	3.02	5	Clayey Silt to Silty Clay	ML/CL	stiff	120	2.5	7	1.14	95				0.98	>10		
6.70	22.0	17.85	2.40	5	Clayey Silt to Silty Clay	ML/CL	very stiff	120	2.5	7	1.13	90				1.00	>10		
6.85	22.5	19.44	2.86	5	Clayey Silt to Silty Clay	ML/CL	very stiff	120	2.5	8	1.12	90				1.09	>10		
7.00	23.0	18.77	2.78	5	Clayey Silt to Silty Clay	ML/CL	very stiff	120	2.5	8	1.12	90				1.08	>10		
7.18	23.5	21.42	4.25	4	Silty Clay to Clay	CL	very stiff	125	1.8	12	1.11	100				1.21	>10		
7.33	24.0	20.36	4.72	3	Clay	CL/CH	very stiff	125	1.3	16	1.10	100				1.15	9.79		
7.48	24.5	22.88	5.78	3	Clay	CL/CH	very stiff	125	1.3	18	1.09	100				1.30	>10		
7.63	25.0	18.87	4.52	3	Clay	CL/CH	stiff	125	1.3	13	1.08	100				0.93	6.32		
7.78	25.5	15.65	4.45	3	Clay	CL/CH	stiff	125	1.3	13	1.07	100				0.87	5.53		
7.93	26.0	15.89	4.31	3	Clay	CL/CH	stiff	125	1.3	13	1.08	100				0.87	5.42		
8.08	26.5	20.63	4.90	3	Clay	CL/CH	very stiff	125	1.3	18	1.05	100				1.15	8.41		
8.23	27.0	15.37	7.07	3	Clay	CL/CH	stiff	125	1.3	12	1.04	100				0.85	5.00		
8.38	27.5	11.14	5.34	3	Clay	CL/CH	stiff	125	1.3	9	1.03	100				0.60	3.07		
8.53	28.0	12.31	5.05	3	Clay	CL/CH	stiff	125	1.3	10	1.03	100				0.67	3.43		
8.68	28.5	14.37	7.77	3	Clay	CL/CH	stiff	125	1.3	11	1.02	100				0.79	4.18		
8.85	29.0	17.43	8.21	3	Clay	CL/CH	stiff	125	1.3	14	1.01	100				0.88	5.53		
9.00	29.5	12.84	7.20	3	Clay	CL/CH	stiff	125	1.3	10	1.00	100				0.69	3.35		
9.15	30.0	11.98	4.89	3	Clay	CL/CH	stiff	125	1.3	10	0.99	100				0.64	3.07		
9.30	30.5	14.34	4.89	3	Clay	CL/CH	stiff	125	1.3	11	0.99	100				0.78	3.83		

LANDMARK CONSULTANTS, INC.

CONE PENETROMETER INTERPRETATION (based on Robertson & Campanella, 1989, refer to Key to CPT logs)

Project: JR Simplot Fertilizer Terminal

Project No: LE07435

Date: 11/19/07

CONE SOUNDING: CPT-1

Base Depth		Avg Tip		Avg Friction		Soil		Soil Classification		USC		Density or Consistency		Est Density	Qc	SPT	Cn	Phi Correlation	Est Rel	Nk	17.0	OCR
meters	feet	Qc, tsf	Ratio, %	Type									(pcf)	N	N(60)	Cq	Qc1n	% Fines	Dr (%)	Phi (deg.)	Su (tsf)	
9.45	31.0	16.64	6.02	3	3	Clay	CL/CH	stiff	125	1.3	13	0.98					100				0.93	4.78
9.80	31.5	22.94	6.44	3	3	Clay	CL/CH	very stiff	125	1.3	18	0.97					100				1.28	7.85
9.75	32.0	22.36	7.19	3	3	Clay	CL/CH	very stiff	125	1.3	18	0.97					100				1.25	7.27
9.90	32.5	18.62	6.64	3	3	Clay	CL/CH	stiff	125	1.3	13	0.96					100				0.92	4.47
10.05	33.0	16.66	5.46	3	3	Clay	CL/CH	stiff	125	1.3	13	0.95					100				0.91	4.28
10.20	33.5	16.86	5.68	3	3	Clay	CL/CH	very stiff	125	1.3	15	0.95					100				1.04	5.10
10.38	34.0	18.77	6.10	3	3	Clay	CL/CH	very stiff	125	1.3	15	0.94					100				1.03	5.00
10.53	34.5	18.33	6.19	3	3	Clay	CL/CH	very stiff	125	1.3	15	0.93					100				1.01	4.88
10.66	35.0	18.51	6.55	3	3	Clay	CL/CH	very stiff	125	1.3	15	0.93					100				1.02	4.68
10.83	35.5	18.81	6.22	3	3	Clay	CL/CH	very stiff	125	1.3	15	0.92					100				1.02	4.57
10.98	36.0	17.57	5.86	3	3	Clay	CL/CH	stiff	125	1.3	14	0.92					100				0.97	4.18
11.13	36.5	22.22	6.00	3	3	Clay	CL/CH	very stiff	125	1.3	18	0.91					100				1.23	5.88
11.28	37.0	18.18	3.18	5	5	Clayey Silt to Silty Clay	ML/CL	stiff	120	2.5	7	0.91					100				0.89	7.41
11.43	37.5	15.81	5.02	3	3	Clay	CL/CH	stiff	125	1.3	13	0.90					100				0.85	3.35
11.58	38.0	20.80	5.53	3	3	Clay	CL/CH	very stiff	125	1.3	16	0.90					100				1.13	4.89
11.73	38.5	19.98	4.13	4	4	Silty Clay to Clay	CL	very stiff	125	1.8	11	0.89					100				1.10	6.00
11.88	39.0	22.86	4.42	4	4	Silty Clay to Clay	CL	very stiff	125	1.8	13	0.88					100				1.27	7.27
12.05	39.5	20.85	5.08	3	3	Clay	CL/CH	very stiff	125	1.3	17	0.88					100				1.15	4.78
12.20	40.0	18.55	3.95	4	4	Silty Clay to Clay	CL	stiff	125	1.8	9	0.88					100				0.89	4.09
12.35	40.5	13.23	3.43	4	4	Silty Clay to Clay	CL	stiff	125	1.8	8	0.87					100				0.70	3.00
12.50	41.0	11.77	3.40	4	4	Silty Clay to Clay	CL	stiff	125	1.8	7	0.87					100				0.61	2.41
12.65	41.5	11.12	3.04	4	4	Silty Clay to Clay	CL	stiff	125	1.8	8	0.88					100				0.57	2.20
12.80	42.0	11.14	2.44	5	5	Clayey Silt to Silty Clay	ML/CL	stiff	120	2.5	4	0.86					100				0.57	2.82
12.95	42.5	15.17	2.26	5	5	Clayey Silt to Silty Clay	ML/CL	stiff	120	2.5	6	0.85					100				0.81	4.37
13.10	43.0	16.73	2.22	5	5	Clayey Silt to Silty Clay	ML/CL	stiff	120	2.5	7	0.85					100				0.90	5.10
13.25	43.5	16.45	2.13	5	5	Clayey Silt to Silty Clay	ML/CL	stiff	120	2.5	7	0.84					100				0.86	4.89
13.40	44.0	27.13	3.79	5	5	Clayey Silt to Silty Clay	ML/CL	very stiff	120	2.5	11	0.84					100				1.51	>10
13.58	44.5	88.11	2.12	7	7	Silty Sand to Sandy Silt	SM/ML	medium dense	115	4.5	19	0.84	68.0	55	61	37						
13.73	45.0	118.16	2.04	7	7	Silty Sand to Sandy Silt	SM/ML	medium dense	115	4.5	26	0.83	91.4	45	70	38						
13.88	45.5	207.62	2.02	8	8	Sand to Silty Sand	SP/SM	dense	115	5.5	38	0.83	162.5	35	87	40						
14.03	46.0	148.38	3.05	6	6	Sandy Silt to Clayey Silt	ML	dense	115	3.5	43	0.83	116.5	50	77	39						
14.18	46.5	81.90	2.82	6	6	Sandy Silt to Clayey Silt	ML	medium dense	115	3.5	23	0.82	63.6	60	58	38						
14.33	47.0	159.45	1.81	8	8	Sand to Silty Sand	SP/SM	dense	115	5.5	29	0.82	123.3	35	79	39						
14.48	47.5	184.20	2.43	7	7	Silty Sand to Sandy Silt	SM/ML	dense	115	4.5	36	0.81	126.5	40	79	39						
14.63	48.0	140.10	2.02	7	7	Silty Sand to Sandy Silt	SM/ML	dense	115	4.5	31	0.81	107.5	40	75	38						
14.78	48.5	109.73	2.85	7	7	Silty Sand to Sandy Silt	SM/ML	medium dense	115	4.5	24	0.81	83.8	55	67	37						
14.93	49.0	83.10	3.32	6	6	Sandy Silt to Clayey Silt	ML	medium dense	115	3.5	24	0.80	63.2	65	59	38						
15.10	49.5	88.44	2.08	7	7	Silty Sand to Sandy Silt	SM/ML	medium dense	115	4.5	19	0.80	66.5	65	60	38						
15.25	50.0	106.35	1.97	7	7	Silty Sand to Sandy Silt	SM/ML	medium dense	115	4.5	24	0.80	80.3	50	66	37						

CLIENT: DD&E

CONE PENETROMETER: Middle Earth Geolasting, Inc. Truck Mounted Electric
Cone with 23 ton reaction weight

PROJECT: JR Simplot Fertilizer Terminal – Imperial, CA

DATE: 11/19/07

LOCATION: See Site and Boring Location Plan

LOG OF CONE SOUNDING DATA CPT-2

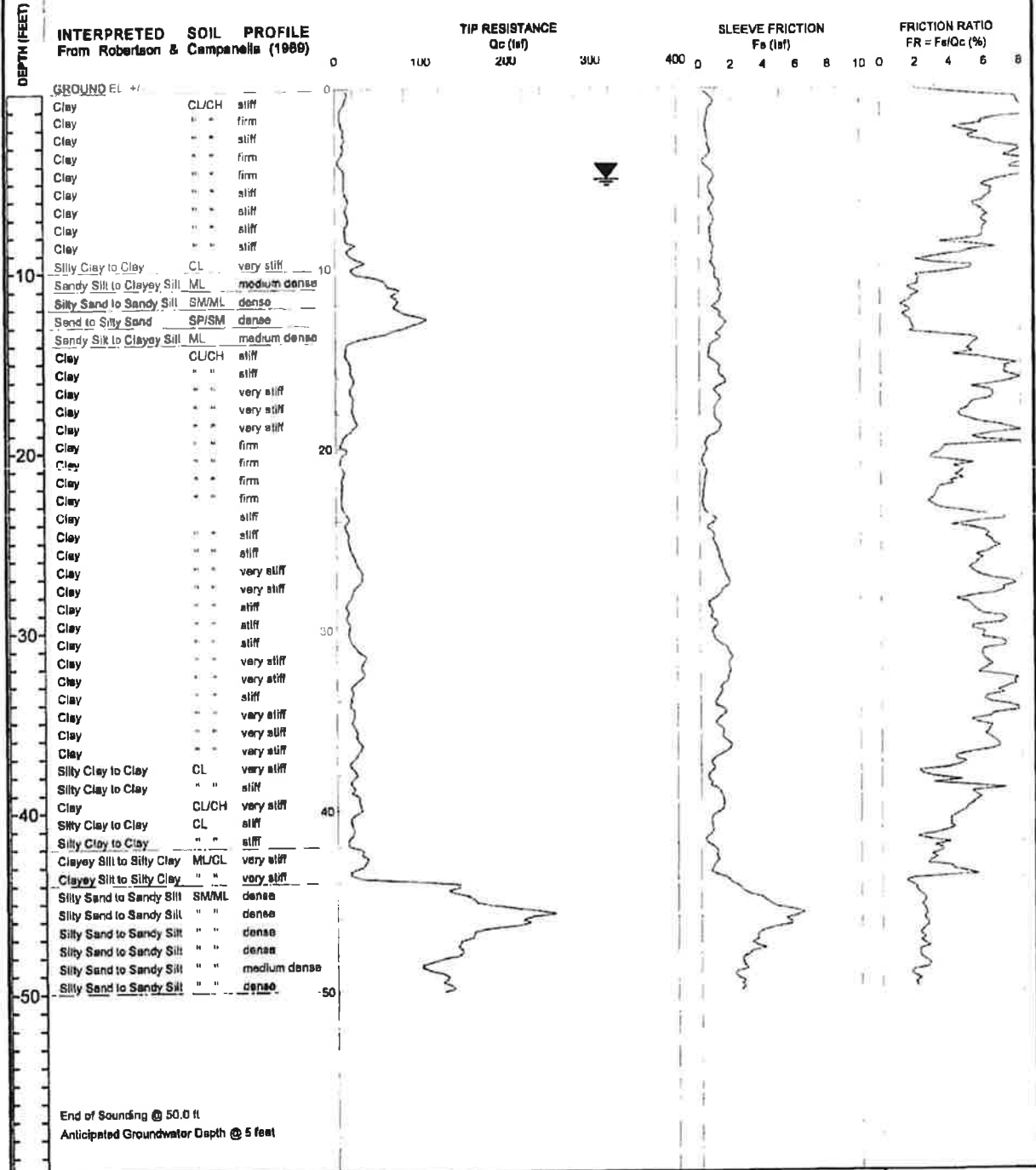

Project No:
LE07435



Plate
B-2

LANDMARK CONSULTANTS, INC.

CONE PENETROMETER INTERPRETATION (based on Robertson & Campanella, 1989, refer to Key to CPT logs)

Project: JR Simplot Fertilizer Terminal

Project No: LE07435

Date: 11/19/07

CONE SOUNDING: CPT-2

Est GWT (ft): 5.0

Base Depth meters	Base Depth feet	Avg Tip Qc, tsf	Avg Friction Ratio, %	Soil Type	Soil Classification	USC	Density or Consistency	Est Density (pcf)	Qc N	Cn N(60)	Phi Correlation or Norm. Cq	Est % Fines	Est Rel Dens Dr (%)	Nk	Su (ksf)	OCR
0.15	0.5	13.16	3.65	3	Clay	CL/CH	stiff	125	1.3	11	2.00	90			0.77	>10
0.30	1.0	10.31	7.80	3	Clay	CL/CH	stiff	125	1.3	8	2.00	100			0.80	>10
0.45	1.5	5.83	9.11	1	Organic Material	OL/OH	firm	120	1.0	8	2.00	100			0.33	>10
0.60	2.0	5.98	7.03	3	Clay	CL/CH	firm	125	1.3	5	2.00	100			0.34	>10
0.75	2.5	8.74	4.80	3	Clay	CL/CH	stiff	125	1.3	7	2.00	100			0.51	>10
0.93	3.0	9.93	5.32	3	Clay	CL/CH	stiff	125	1.3	8	2.00	100			0.57	>10
1.08	3.5	8.73	6.88	3	Clay	CL/CH	stiff	125	1.3	7	2.00	100			0.60	>10
1.23	4.0	5.95	7.54	3	Clay	CL/CH	firm	125	1.3	5	2.00	100			0.34	>10
1.38	4.5	4.95	8.03	1	Organic Material	OL/OH	firm	120	1.0	5	2.00	100			0.28	8.85
1.53	5.0	10.28	8.27	3	Clay	CL/CH	stiff	125	1.3	8	1.90	100			0.59	>10
1.68	5.5	10.08	6.58	3	Clay	CL/CH	stiff	125	1.3	8	1.85	100			0.57	>10
1.83	6.0	12.07	6.35	3	Clay	CL/CH	stiff	125	1.3	10	1.80	100			0.68	>10
1.98	6.5	13.85	5.74	3	Clay	CL/CH	stiff	125	1.3	11	1.78	100			0.79	>10
2.13	7.0	12.23	5.72	3	Clay	CL/CH	stiff	125	1.3	10	1.72	100			0.70	>10
2.28	7.5	14.31	5.85	3	Clay	CL/CH	stiff	125	1.3	11	1.69	100			0.82	>10
2.45	8.0	11.03	6.00	3	Clay	CL/CH	stiff	125	1.3	8	1.65	100			0.63	>10
2.60	8.5	11.94	5.78	3	Clay	CL/CH	stiff	125	1.3	10	1.62	100			0.68	>10
2.75	9.0	17.74	5.10	3	Clay	CL/CH	very stiff	125	1.3	14	1.59	90			1.02	>10
2.90	9.5	19.36	4.23	4	Silty Clay to Clay	CL	very stiff	125	1.8	11	1.56	80			1.11	>10
3.05	10.0	26.66	3.42	5	Clayey Silt to Silty Clay	ML/CL	very stiff	120	2.5	11	1.53	65			1.54	>10
3.20	10.5	29.46	3.75	5	Clayey Silt to Silty Clay	ML/CL	very stiff	120	2.5	12	1.51	65			1.71	>10
3.35	11.0	58.15	2.15	7	Silty Sand to Sandy Silt	SM/ML	medium dense	115	4.5	13	1.49	81.7	35	67	37	
3.50	11.5	89.52	1.84	7	Silty Sand to Sandy Silt	SM/ML	dense	115	4.5	15	1.47	96.4	30	71	38	
3.65	12.0	70.85	1.84	7	Silty Sand to Sandy Silt	SM/ML	dense	115	4.5	16	1.45	97.0	30	72	38	
3.80	12.5	72.98	1.47	7	Silty Sand to Sandy Silt	SM/ML	dense	115	4.5	18	1.43	98.5	25	72	38	
3.95	13.0	100.58	1.46	8	Sand to Silty Sand	SP/SM	dense	115	5.5	18	1.41	134.2	20	81	38	
4.13	13.5	77.30	1.82	7	Silty Sand to Sandy Silt	SM/ML	dense	115	4.5	17	1.39	102.1	30	73	38	
4.28	14.0	41.08	3.43	5	Clayey Silt to Silty Clay	ML/CL	hard	120	2.5	18	1.38	80			2.38	>10
4.43	14.5	12.88	5.40	3	Clay	CL/CH	stiff	125	1.3	10	1.36	100			0.71	8.85
4.58	15.0	11.77	4.81	3	Clay	CL/CH	stiff	125	1.3	9	1.34	100			0.68	7.41
4.73	15.5	18.18	8.71	3	Clay	CL/CH	stiff	125	1.3	13	1.32	100			0.92	>10
4.88	16.0	18.44	7.15	3	Clay	CL/CH	very stiff	125	1.3	15	1.31	100			1.05	>10
5.03	16.5	19.13	7.30	3	Clay	CL/CH	very stiff	125	1.3	15	1.29	100			1.09	>10
5.18	17.0	17.26	5.99	3	Clay	CL/CH	stiff	125	1.3	14	1.27	100			0.98	>10
5.33	17.5	18.86	6.01	3	Clay	CL/CH	very stiff	125	1.3	16	1.28	100			1.13	>10
5.48	18.0	19.19	4.91	3	Clay	CL/CH	very stiff	125	1.3	15	1.25	100			1.09	>10
5.65	18.5	22.82	4.75	3	Clay	CL/CH	very stiff	125	1.3	18	1.23	90			1.30	>10
5.80	19.0	19.93	6.88	3	Clay	CL/CH	very stiff	125	1.3	18	1.22	100			1.13	>10
5.95	19.5	9.57	6.55	3	Clay	CL/CH	stiff	125	1.3	8	1.20	100			0.52	3.74
6.10	20.0	7.82	5.88	3	Clay	CL/CH	firm	125	1.3	6	1.19	100			0.40	2.65
6.25	20.5	8.83	3.31	3	Clay	CL/CH	firm	125	1.3	7	1.18	100			0.48	3.07
6.40	21.0	5.07	4.07	3	Clay	CL/CH	firm	125	1.3	4	1.17	100			0.25	1.37
6.55	21.5	9.08	4.82	3	Clay	CL/CH	firm	125	1.3	7	1.18	100			0.49	3.14
6.70	22.0	7.01	4.38	3	Clay	CL/CH	firm	125	1.3	8	1.14	100			0.37	2.06
6.85	22.5	7.02	3.60	3	Clay	CL/CH	firm	125	1.3	8	1.13	100			0.38	2.00
7.00	23.0	6.55	3.08	3	Clay	CL/CH	firm	125	1.3	5	1.12	100			0.34	1.77
7.18	23.5	7.65	3.02	4	Silty Clay to Clay	CL	firm	125	1.8	4	1.11	100			0.40	2.73
7.35	24.0	13.71	5.70	3	Clay	CL/CH	stiff	125	1.3	11	1.10	100			0.76	5.00
7.48	24.5	11.45	5.50	3	Clay	CL/CH	stiff	125	1.3	9	1.09	100			0.62	3.86
7.63	25.0	14.16	5.84	3	Clay	CL/CH	stiff	125	1.3	11	1.08	100			0.78	5.00
7.78	25.5	14.85	6.25	3	Clay	CL/CH	stiff	125	1.3	12	1.07	100			0.82	5.21
7.93	26.0	18.15	6.43	3	Clay	CL/CH	very stiff	125	1.3	15	1.06	100			1.01	7.00
8.08	26.5	23.81	5.81	3	Clay	CL/CH	very stiff	125	1.3	19	1.06	100			1.35	>10
8.23	27.0	30.25	5.23	3	Clay	CL/CH	very stiff	125	1.3	24	1.05	85			1.72	>10
8.38	27.5	28.21	8.54	3	Clay	CL/CH	very stiff	125	1.3	23	1.04	100			1.60	>10
8.53	28.0	19.70	7.22	3	Clay	CL/CH	very stiff	125	1.3	18	1.03	100			1.10	7.27
8.68	28.5	14.88	5.32	3	Clay	CL/CH	stiff	125	1.3	12	1.02	100			0.82	4.47
8.85	29.0	12.82	5.17	3	Clay	CL/CH	stiff	125	1.3	10	1.02	100			0.88	3.43
9.00	29.5	12.31	6.13	3	Clay	CL/CH	stiff	125	1.3	10	1.01	100			0.88	3.28
9.15	30.0	15.38	8.43	3	Clay	CL/CH	stiff	125	1.3	12	1.00	100			0.84	4.37
9.30	30.5	14.61	5.67	3	Clay	CL/CH	stiff	125	1.3	12	0.99	100			0.80	3.91

LANDMARK CONSULTANTS, INC.

CONE PENETROMETER INTERPRETATION (based on Robertson & Campanella, 1989, refer to Key to CPT logs)

Project: JR Simplot Fertilizer Terminal Project No: LE07435 Date: 11/19/07

CONE SOUNDING: CPT-2

Est GWT (ft)		5.0		Phi Correlation		0		0.8cm(76)		1-N&C(83)		2-PMT(74)				
Base Depth	Base Depth	Avg Tip	Avg Friction	Soil Type	Soil Classification	USC	Density or Consistency	Est Density (pcf)	Qc to SPT N(60)	Cn or Cq	Phi Norm	Est % Fines	Rel. Dens (deg)	Nk	Su (tsf)	OCR
9.45	31.0	18.46	6.80	3	Clay	CU/CH	very stiff	128	1.3	16	0.89	100			1.08	6.10
9.80	31.5	20.89	6.23	3	Clay	CU/CH	very stiff	125	1.3	24	0.88	100			1.88	>10
9.75	32.0	31.63	5.92	3	Clay	CU/CH	very stiff	125	1.3	25	0.97	100			1.79	>10
9.90	32.5	30.71	6.11	3	Clay	CU/CH	very stiff	125	1.3	25	0.96	100			1.74	>10
10.05	33.0	25.97	8.77	3	Clay	CU/CH	very stiff	125	1.3	21	0.88	100			1.46	8.19
10.20	33.5	17.77	7.47	3	Clay	CU/CH	stiff	125	1.3	14	0.85	100			0.98	4.88
10.36	34.0	17.70	6.58	3	Clay	CU/CH	stiff	125	1.3	14	0.95	100			0.97	4.57
10.53	34.5	17.08	6.48	3	Clay	CU/CH	stiff	125	1.3	14	0.94	100			0.83	4.28
10.68	35.0	20.25	7.34	3	Clay	CU/CH	very stiff	125	1.3	16	0.93	100			1.12	5.42
10.83	35.5	18.88	5.85	3	Clay	CU/CH	very stiff	125	1.3	15	0.93	100			1.03	4.88
10.98	36.0	23.18	6.21	3	Clay	CU/CH	very stiff	125	1.3	18	0.92	100			1.29	8.54
11.13	36.5	27.03	6.33	3	Clay	CU/CH	very stiff	125	1.3	22	0.82	100			1.52	8.41
11.28	37.0	24.47	6.11	3	Clay	CU/CH	very stiff	125	1.3	20	0.91	100			1.35	6.88
11.43	37.5	18.35	4.47	3	Clay	CU/CH	stiff	125	1.3	13	0.80	100			0.89	3.58
11.58	38.0	21.47	3.51	5	Clayey Silt to Silty Clay	ML/CL	very stiff	120	2.5	8	0.90	100			1.19	>10
11.73	38.5	17.45	3.34	5	Clayey Silt to Silty Clay	ML/CL	stiff	120	2.5	7	0.88	100			0.95	6.54
11.88	38.0	18.94	5.12	3	Clay	CU/CH	very stiff	125	1.3	15	0.89	100			1.04	4.18
12.05	39.5	25.50	5.43	3	Clay	CU/CH	very stiff	125	1.3	20	0.88	100			1.42	8.85
12.20	40.0	28.08	5.17	3	Clay	CU/CH	very stiff	125	1.3	22	0.88	100			1.57	7.70
12.35	40.5	19.00	4.55	3	Clay	CU/CH	very stiff	125	1.3	15	0.87	100			1.04	4.00
12.50	41.0	17.39	3.98	4	Silty Clay to Clay	CL	stiff	125	1.8	10	0.87	100			0.94	4.37
12.65	41.5	17.52	3.88	4	Silty Clay to Clay	CL	stiff	125	1.8	10	0.86	100			0.95	4.37
12.80	42.0	13.24	2.81	5	Clayey Silt to Silty Clay	ML/CL	stiff	120	2.5	5	0.88	100			0.89	3.86
12.95	42.5	29.45	3.35	5	Clayey Silt to Silty Clay	ML/CL	very stiff	120	2.5	12	0.86	100			1.65	>10
13.10	43.0	34.82	2.98	5	Clayey Silt to Silty Clay	ML/CL	very stiff	120	2.5	14	0.85	90			1.95	>10
13.25	43.5	21.25	3.59	5	Clayey Silt to Silty Clay	ML/CL	very stiff	120	2.5	8	0.85	100			1.16	7.70
13.40	44.0	48.89	4.12	5	Clayey Silt to Silty Clay	ML/CL	hard	120	2.5	20	0.84	90			2.79	>10
13.58	44.5	138.40	1.88	8	Sand to Silty Sand	SP/SM	dense	115	5.5	25	0.84	109.8	35	75	39	
13.73	45.0	150.88	2.17	7	Silty Sand to Sandy Silt	SM/ML	dense	115	4.5	34	0.84	119.2	40	78	39	
13.88	45.5	182.92	2.41	7	Silty Sand to Sandy Silt	SM/ML	dense	115	4.5	41	0.83	143.8	40	83	40	
14.03	46.0	240.12	2.53	7	Silty Sand to Sandy Silt	SM/ML	very dense	115	4.5	53	0.83	188.0	35	91	41	
14.18	46.5	218.82	2.52	7	Silty Sand to Sandy Silt	SM/ML	dense	115	4.5	49	0.82	170.5	35	88	40	
14.33	47.0	163.39	2.37	7	Silty Sand to Sandy Silt	SM/ML	dense	115	4.5	38	0.82	128.9	40	80	39	
14.48	47.5	142.85	2.37	7	Silty Sand to Sandy Silt	SM/ML	dense	115	4.5	32	0.82	110.3	45	75	39	
14.63	48.0	144.49	2.37	7	Silty Sand to Sandy Silt	SM/ML	dense	115	4.5	32	0.81	111.3	45	76	39	
14.78	48.5	111.35	2.37	7	Silty Sand to Sandy Silt	SM/ML	medium dense	115	4.5	25	0.81	85.4	50	68	37	
14.93	49.0	110.33	2.41	7	Silty Sand to Sandy Silt	SM/ML	medium dense	115	4.5	25	0.81	84.3	50	67	37	
15.10	49.5	126.27	1.91	7	Silty Sand to Sandy Silt	SM/ML	dense	115	4.5	28	0.80	86.1	45	71	38	
15.25	50.0	131.55	1.96	7	Silty Sand to Sandy Silt	SM/ML	dense	115	4.5	29	0.80	99.7	45	72	38	

CLIENT: DD&E
 PROJECT: JR Simplot Fertilizer Terminal – Imperial, CA
 LOCATION: See Site and Boring Location Plan

CONE PENETROMETER: Middle Earth Geotesting, Inc. Truck Mounted Electric
 Cone with 23 ton reaction weight
 DATE: 11/19/07

LOG OF CONE SOUNDING DATA CPT-3

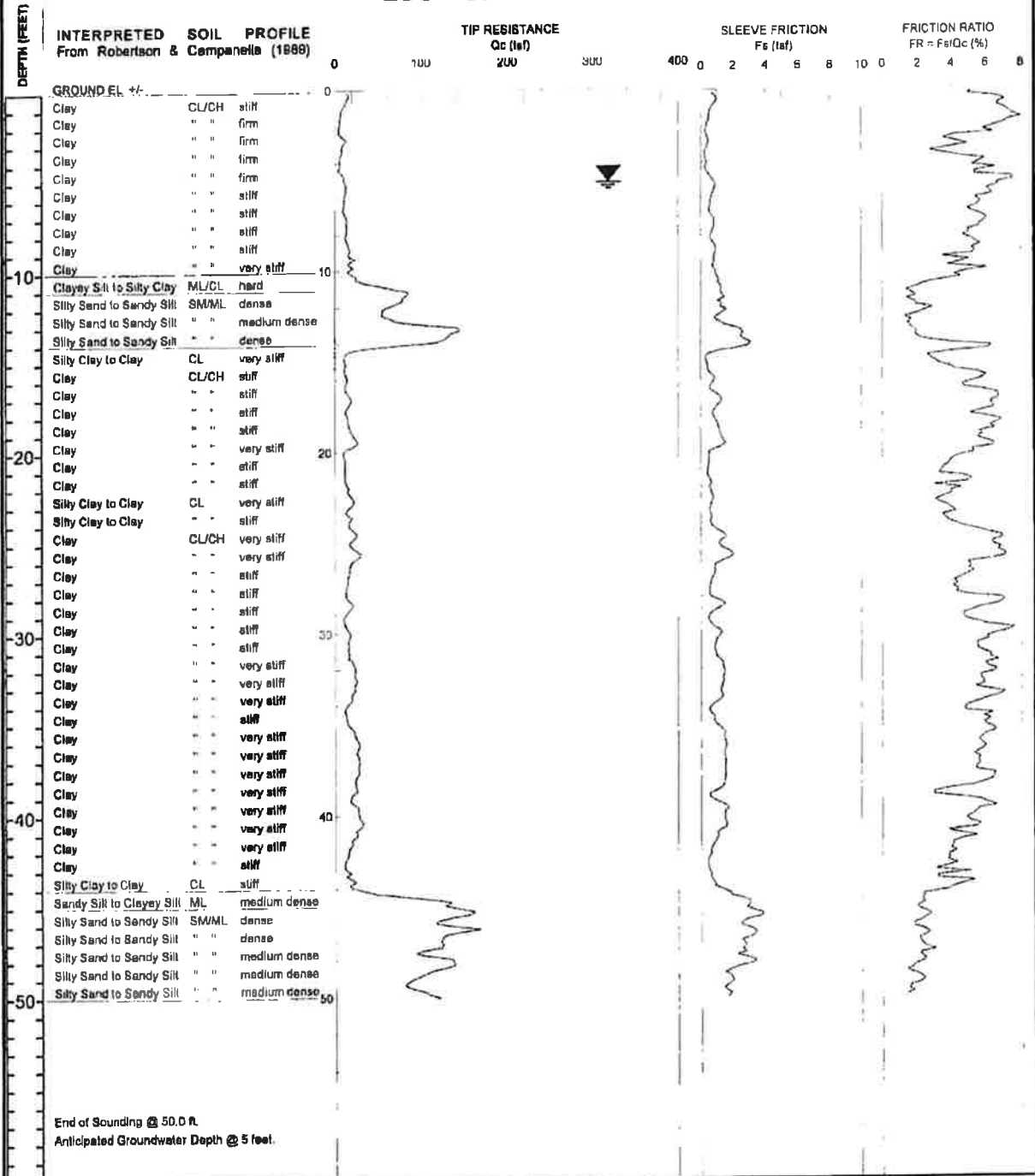

Project No:
LE07435



Plate
B-3

LANDMARK CONSULTANTS, INC.

CONE PENETROMETER INTERPRETATION (based on Robertson & Campanella, 1989, refer to Key to CPT logs)

Project: JR Simplot Fertilizer Terminal Project No: LE07435 Date: 11/19/07
 CONE SOUNDING: CPT-3

Est. GWT (ft): 5.0		Phi Correlation															
Base Depth	Base Depth	Avg Tip	Avg Friction	1 Soil	Soil Classification	USC	Density or Consistency	Est Density (pcf)	Qc to N	SPT N(60)	Cn or Cq	Norm. Qc1m	Est. % Fines	Rel. Dens.	Nk (deg)	Su (tsf)	OCR
0.15	0.5	15.28	5.58	3	Clay	CL/CH	stiff	125	1.3	12	2.00		95			0.90	>10
0.30	1.0	11.20	6.84	3	Clay	CL/CH	stiff	125	1.3	9	2.00		100			0.86	>10
0.45	1.5	7.24	7.30	3	Clay	CL/CH	firm	125	1.3	8	2.00		100			0.42	>10
0.60	2.0	5.66	7.45	3	Clay	CL/CH	firm	125	1.3	5	2.00		100			0.33	>10
0.75	2.5	4.83	6.26	3	Clay	CL/CH	firm	125	1.3	4	2.00		100			0.28	>10
0.93	3.0	11.50	3.99	3	Clay	CL/CH	stiff	125	1.3	9	2.00		95			0.67	>10
1.08	3.5	8.20	3.87	3	Clay	CL/CH	firm	125	1.3	7	2.00		100			0.47	>10
1.23	4.0	6.28	4.89	3	Clay	CL/CH	firm	125	1.3	5	2.00		100			0.35	>10
1.38	4.5	6.12	5.81	3	Clay	CL/CH	firm	125	1.3	4	2.00		100			0.29	5.88
1.53	5.0	10.01	6.05	3	Clay	CL/CH	stiff	125	1.3	8	1.89		100			0.57	>10
1.68	5.5	12.73	6.76	3	Clay	CL/CH	stiff	128	1.3	10	1.84		100			0.73	>10
1.83	6.0	11.01	6.03	3	Clay	CL/CH	stiff	125	1.3	9	1.80		100			0.63	>10
1.98	6.5	10.30	5.55	3	Clay	CL/CH	stiff	125	1.3	8	1.75		100			0.59	>10
2.13	7.0	12.11	5.34	3	Clay	CL/CH	stiff	125	1.3	10	1.72		100			0.69	>10
2.28	7.5	13.82	5.90	3	Clay	CL/CH	stiff	125	1.3	11	1.88		100			0.79	>10
2.45	8.0	13.39	5.18	3	Clay	CL/CH	stiff	125	1.3	11	1.85		100			0.78	>10
2.60	8.5	14.05	5.08	3	Clay	CL/CH	stiff	125	1.3	11	1.61		100			0.80	>10
2.75	9.0	16.87	5.43	3	Clay	CL/CH	stiff	125	1.3	13	1.58		95			0.97	>10
2.90	9.5	16.73	4.59	3	Clay	CL/CH	very stiff	125	1.3	15	1.55		85			1.08	>10
3.05	10.0	17.40	4.78	3	Clay	CL/CH	stiff	125	1.3	14	1.53		90			1.00	>10
3.20	10.5	22.48	4.87	3	Clay	CL/CH	very stiff	125	1.3	18	1.50		80			1.29	>10
3.35	11.0	50.08	2.52	6	Sandy Silt to Clayey Silt	ML	medium dense	115	3.5	14	1.48	70.0	45	62	37		
3.50	11.5	82.45	1.85	7	Silty Sand to Sandy Silt	SM/ML	dense	115	4.5	18	1.48	113.7	25	78	39		
3.65	12.0	89.74	1.74	7	Silty Sand to Sandy Silt	SM/ML	dense	115	4.5	15	1.44	95.0	30	71	38		
3.80	12.5	54.96	2.45	6	Sandy Silt to Clayey Silt	ML	medium dense	115	3.5	18	1.42	73.9	40	64	37		
3.95	13.0	78.84	1.47	7	Silty Sand to Sandy Silt	SM/ML	dense	119	4.5	18	1.40	104.7	25	74	38		
4.13	13.5	140.18	1.76	8	Sand to Silty Sand	SP/SM	very dense	115	5.5	25	1.39	183.9	20	90	41		
4.28	14.0	125.10	2.21	7	Silty Sand to Sandy Silt	SM/ML	dense	115	4.5	28	1.37	182.2	26	87	40		
4.43	14.5	41.28	5.54	3	Clay	CL/CH	hard	125	1.3	33	1.35		70			2.39	>10
4.58	15.0	11.25	3.08	4	Silty Clay to Clay	CL	stiff	125	1.8	6	1.34		100			0.63	8.00
4.73	15.5	11.87	3.49	4	Silty Clay to Clay	CL	stiff	125	1.8	7	1.32		100			0.86	9.58
4.88	16.0	13.25	6.41	3	Clay	CL/CH	stiff	125	1.3	11	1.30		100			0.74	8.27
5.03	16.5	12.39	4.86	3	Clay	CL/CH	stiff	125	1.3	10	1.28		100			0.89	7.00
5.18	17.0	16.82	6.45	3	Clay	CL/CH	stiff	125	1.3	13	1.27		100			0.95	>10
5.33	17.5	17.04	6.44	3	Clay	CL/CH	stiff	125	1.3	14	1.28		100			0.96	>10
5.48	18.0	13.40	5.77	3	Clay	CL/CH	stiff	125	1.3	11	1.24		100			0.75	7.13
5.65	18.5	15.32	6.58	3	Clay	CL/CH	stiff	125	1.3	12	1.23		100			0.86	8.70
5.80	19.0	18.84	6.18	3	Clay	CL/CH	very stiff	125	1.3	15	1.21		100			1.07	>10
5.95	19.5	24.59	5.74	3	Clay	CL/CH	very stiff	125	1.3	20	1.20		100			1.40	>10
6.10	20.0	14.88	6.04	3	Clay	CL/CH	stiff	125	1.3	12	1.18		100			0.83	7.27
6.25	20.5	11.14	4.65	3	Clay	CL/CH	stiff	125	1.3	9	1.18		100			0.81	4.37
6.40	21.0	11.84	3.78	3	Clay	CL/CH	stiff	125	1.3	9	1.16		100			0.65	4.88
6.55	21.5	11.80	3.93	3	Clay	CL/CH	stiff	125	1.3	9	1.15		100			0.85	4.47
6.70	22.0	14.21	4.36	3	Clay	CL/CH	stiff	125	1.3	11	1.14		100			0.79	6.00
6.85	22.5	16.58	4.19	3	Clay	CL/CH	stiff	125	1.3	13	1.13		100			0.93	7.41
7.00	23.0	20.83	3.32	5	Clayey Silt to Silty Clay	ML/CL	very stiff	120	2.5	8	1.12		90			1.18	>10
7.18	23.5	14.37	4.06	3	Clay	CL/CH	stiff	125	1.3	11	1.11		100			0.79	5.53
7.33	24.0	17.81	3.88	4	Silty Clay to Clay	CL	stiff	125	1.8	10	1.10		100			1.00	>10
7.48	24.5	20.02	4.79	3	Clay	CL/CH	very stiff	125	1.3	16	1.09		100			1.13	8.19
7.63	25.0	21.45	6.83	3	Clay	CL/CH	very stiff	125	1.3	17	1.08		100			1.21	>10
7.78	25.5	20.43	6.58	3	Clay	CL/CH	very stiff	125	1.3	16	1.07		100			1.15	8.00
7.93	26.0	27.07	6.86	3	Clay	CL/CH	very stiff	125	1.3	22	1.08		100			1.54	>10
8.08	26.5	17.78	5.35	3	Clay	CL/CH	stiff	125	1.3	14	1.05		100			0.89	6.54
8.23	27.0	15.38	4.92	3	Clay	CL/CH	stiff	125	1.3	12	1.05		100			0.85	5.10
8.38	27.5	14.00	4.21	3	Clay	CL/CH	stiff	125	1.3	11	1.04		100			0.77	4.28
8.53	28.0	13.03	4.58	3	Clay	CL/CH	stiff	125	1.3	10	1.03		100			0.71	3.74
8.68	28.5	19.48	6.90	3	Clay	CL/CH	very stiff	125	1.3	18	1.02		100			1.09	8.88
8.85	29.0	13.84	5.31	3	Clay	CL/CH	stiff	125	1.3	11	1.01		100			0.75	3.91
9.00	29.5	10.90	5.03	3	Clay	CL/CH	stiff	125	1.3	9	1.01		100			0.68	2.73
9.15	30.0	15.94	6.89	3	Clay	CL/CH	stiff	125	1.3	13	1.00		100			0.89	4.57
9.30	30.5	16.26	6.31	3	Clay	CL/CH	stiff	125	1.3	13	0.99		100			0.89	4.88

LANDMARK CONSULTANTS, INC.

CONE PENETROMETER INTERPRETATION (based on Robertson & Campanella, 1989, refer to Key to CPT logs)

Project: JR Simplot Fertilizer Terminal Project No: LE07435 Date: 11/19/07
 CONE SOUNDING: CPT-3

Base		Base		Avg		Avg		1		Phi Correlation		0		0-Schm(70)		1-RAC(83)		2-PIT(74)		
Depth	Depth	Tip	Friction	Soil		Density or	Density	to	SPT	or	Norm.	%	Dens	Phi	Su					
meters	feet	Qc, tsf	Ratio, %	Type	Classification	USC	(pcf)	N	N(60)	Cq	Qc1n	Fines	Dr (%)	(deg.)	(tsf)	OCR				
9.45	31.0	15.05	5.50	3	Clay	CU/CH	stiff	125	1.3	13	0.88	100			0.87	4.37				
9.60	31.5	17.29	6.12	3	Clay	CU/CH	stiff	125	1.3	14	0.88	100			0.95	4.89				
9.75	32.0	22.29	6.28	3	Clay	CU/CH	very stiff	125	1.3	18	0.97	100			1.25	7.27				
9.90	32.5	22.92	6.27	3	Clay	CU/CH	very stiff	125	1.3	18	0.86	100			1.28	7.41				
10.05	33.0	23.32	5.84	3	Clay	CU/CH	very stiff	125	1.3	19	0.86	100			1.30	7.58				
10.20	33.5	20.62	6.24	3	Clay	CU/CH	very stiff	125	1.3	16	0.95	100			1.14	6.00				
10.38	34.0	17.36	6.16	3	Clay	CU/CH	stiff	125	1.3	14	0.94	100			0.95	4.47				
10.53	34.5	12.14	4.88	3	Clay	CU/CH	stiff	125	1.3	10	0.94	100			0.64	2.57				
10.68	35.0	13.73	6.19	3	Clay	CU/CH	stiff	125	1.3	11	0.93	100			0.74	3.07				
10.83	35.5	19.77	6.16	3	Clay	CU/CH	very stiff	125	1.3	16	0.93	100			1.09	5.10				
10.98	35.5	19.77	6.16	3	Clay	CU/CH	very stiff	125	1.3	16	0.92	100			1.35	7.00				
10.98	36.0	24.16	6.12	3	Clay	CU/CH	very stiff	125	1.3	21	0.91	100			1.48	8.00				
11.13	36.5	28.36	5.79	3	Clay	CU/CH	very stiff	125	1.3	21	0.91	100			1.52	8.27				
11.28	37.0	27.10	5.49	3	Clay	CU/CH	very stiff	125	1.3	22	0.91	100			1.52	8.14				
11.43	37.5	27.19	5.54	3	Clay	CU/CH	very stiff	125	1.3	22	0.90	100			1.38	6.76				
11.58	38.0	24.82	6.14	3	Clay	CU/CH	very stiff	125	1.3	20	0.90	100			1.31	6.10				
11.73	38.5	23.64	5.98	3	Clay	CU/CH	very stiff	125	1.3	19	0.89	100			1.15	5.85				
11.88	39.0	20.90	3.33	5	Clayey Silt to Silty Clay	ML/CL	very stiff	120	2.5	8	0.89	100			1.20	5.10				
12.05	39.5	21.86	5.40	3	Clay	CU/CH	very stiff	125	1.3	17	0.88	100			1.50	7.13				
12.20	40.0	26.90	5.87	3	Clay	CU/CH	very stiff	125	1.3	22	0.88	100			1.72	8.85				
12.35	40.5	30.81	5.01	3	Clay	CU/CH	very stiff	125	1.3	24	0.87	100			1.44	6.43				
12.50	41.0	29.89	4.98	3	Clay	CU/CH	very stiff	125	1.3	21	0.87	100			1.14	4.47				
12.65	41.5	20.84	4.85	3	Clay	CU/CH	very stiff	125	1.3	17	0.86	100			0.60	3.81				
12.80	42.0	16.71	4.07	4	Silty Clay to Clay	CL	stiff	125	1.8	10	0.86	100			0.71	2.34				
12.95	42.5	13.58	4.01	3	Clay	CU/CH	stiff	125	1.3	11	0.85	100			0.60	1.84				
13.10	43.0	11.88	3.95	3	Clay	CU/CH	stiff	125	1.3	9	0.85	100			0.91	3.83				
13.25	43.5	16.97	3.79	4	Silty Clay to Clay	CL	stiff	125	1.8	10	0.84	100			1.08	3.83				
13.40	44.0	18.79	4.40	3	Clay	CU/CH	very stiff	125	1.3	18	0.84	100			3.08	>10				
13.58	44.5	54.12	3.41	5	Clayey Silt to Silty Clay	ML/CL	hard	120	2.5	22	0.84	80								
13.73	45.0	125.05	2.34	7	Silty Sand to Sandy Silt	SM/ML	dense	115	4.5	28	0.83	98.4	45	72	38					
13.88	45.5	153.94	2.17	7	Silty Sand to Sandy Silt	SM/ML	dense	115	4.5	34	0.83	120.6	40	78	39					
14.03	46.0	123.96	2.49	7	Silty Sand to Sandy Silt	SM/ML	dense	115	4.5	28	0.83	98.7	50	71	38					
14.18	46.5	151.64	1.86	7	Silty Sand to Sandy Silt	SM/ML	dense	115	4.5	34	0.82	117.8	40	77	39					
14.33	47.0	124.27	2.36	7	Silty Sand to Sandy Silt	SM/ML	dense	116	4.5	28	0.82	98.1	45	71	38					
14.48	47.5	108.50	2.80	7	Silty Sand to Sandy Silt	SM/ML	medium dense	115	4.5	24	0.82	82.1	55	67	37					
14.63	48.0	127.00	2.27	7	Silty Sand to Sandy Silt	SM/ML	dense	115	4.5	28	0.81	97.5	45	72	38					
14.78	48.5	125.32	1.93	7	Silty Sand to Sandy Silt	SM/ML	dense	115	4.5	28	0.81	95.8	45	71	38					
14.93	49.0	98.92	1.84	7	Silty Sand to Sandy Silt	SM/ML	medium dense	115	4.5	22	0.81	73.8	50	63	37					
15.10	49.5	84.32	2.08	7	Silty Sand to Sandy Silt	SM/ML	medium dense	115	4.5	19	0.80	83.9	55	59	36					
15.25	50.0	111.78	1.55	8	Sand to Silty Sand	SP/SM	medium dense	115	5.5	20	0.80	84.4	40	67	37					

CLIENT: DD&E
 PROJECT: JR Simplot Fertilizer Terminal -- Imperial, CA
 LOCATION: See Site and Boring Location Plan

CONE PENETROMETER: Middle Earth Geotesting, Inc. Truck Mounted Electric
 Cone with 23 ton reaction weight
 DATE: 11/19/07

LOG OF CONE SOUNDING DATA CPT-4

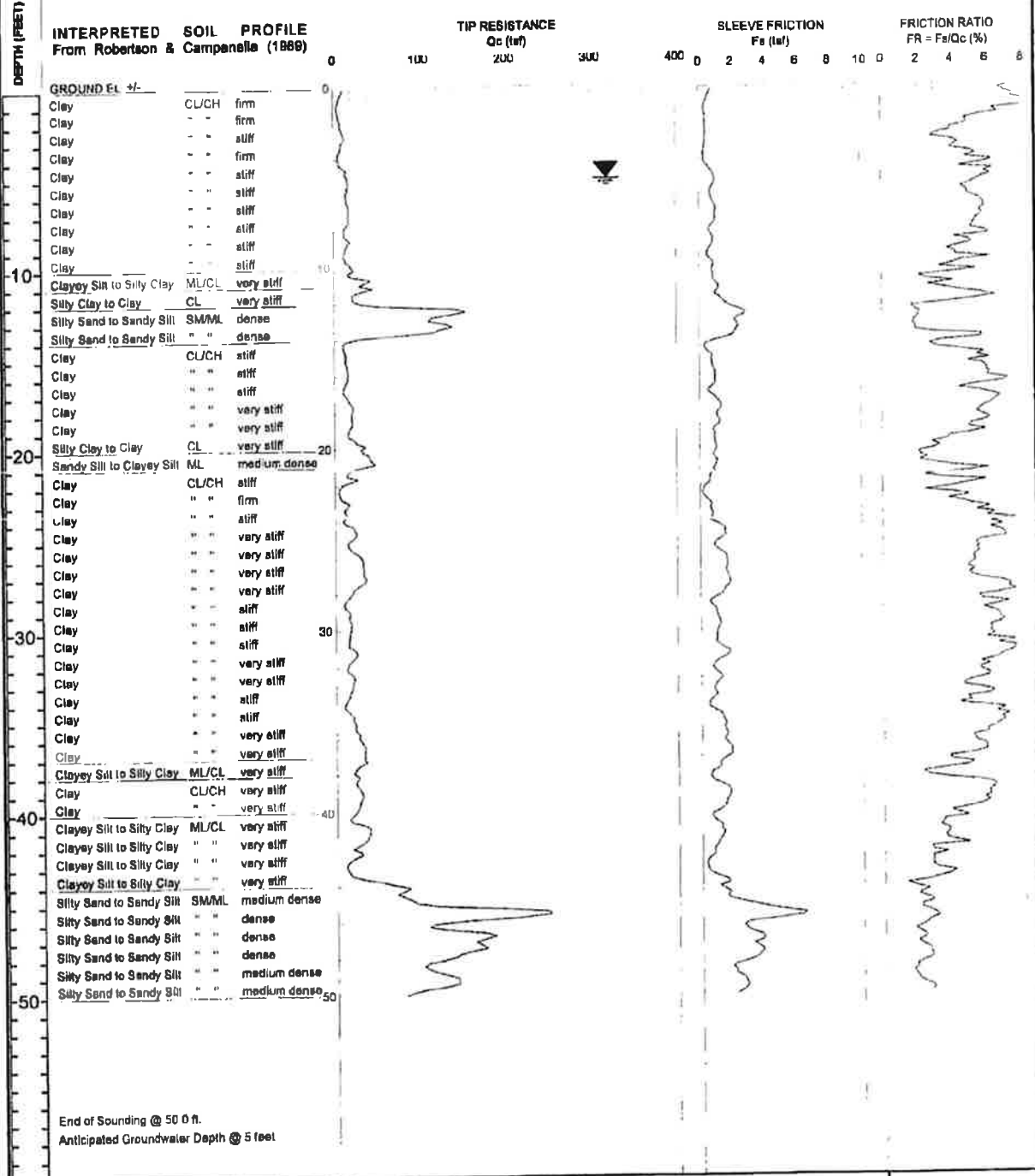

Project No:
LE07435



Plate
B-4

LANDMARK CONSULTANTS, INC.

CONE PENETROMETER INTERPRETATION (based on Robertson & Campanella, 1989, refer to Key to CPT logs)

Project: JR Simplot Fertilizer Terminal Project No: LE07435 Date: 11/19/07

CONE SOUNDING: CPT-4

Est. GWT (ft): 5.0

Base Depth meters	Base Depth feet	Avg Tip qc, tsf	Avg Friction Ratio, %	1 Soil Type	Soil Classification	USC	Density or Consistency	Est Density (pcf)	qc N	Cn N(60)	Phi Correlation		Est % Fines	0-Schm(76) 1-RBC(83) 2-PHT(74) Est Rel. Nk: 17.0	Su (tsf)	OCR	
											or Nom.	QcIn					
0.15	0.5	9.80	8.97	3	Clay	CL/CH	stiff	125	1.3	8	2.00	100		0.58	>10		
0.30	1.0	5.88	7.70	3	Clay	CL/CH	firm	125	1.3	5	2.00	100		0.33	>10		
0.45	1.5	4.38	7.54	1	Organic Material	OL/OH	firm	120	1.0	4	2.00	100		0.25	>10		
0.60	2.0	6.90	5.67	3	Clay	CL/CH	firm	125	1.3	6	2.00	100		0.40	>10		
0.75	2.5	8.90	4.53	3	Clay	CL/CH	stiff	125	1.3	7	2.00	100		0.52	>10		
0.93	3.0	12.43	3.27	4	Silty Clay to Clay	CL	stiff	125	1.6	7	2.00	85		0.72	>10		
1.08	3.5	8.73	4.23	3	Clay	CL/CH	stiff	125	1.3	7	2.00	100		0.50	>10		
1.23	4.0	6.10	4.83	3	Clay	CL/CH	firm	125	1.3	5	2.00	100		0.35	>10		
1.38	4.5	7.30	5.84	3	Clay	CL/CH	firm	125	1.3	6	2.00	100		0.41	>10		
1.53	5.0	14.85	5.59	3	Clay	CL/CH	stiff	125	1.3	12	1.88	100		0.86	>10		
1.68	5.5	18.53	5.58	3	Clay	CL/CH	stiff	125	1.3	13	1.84	95		0.85	>10		
1.83	6.0	14.91	4.79	3	Clay	CL/CH	stiff	125	1.3	12	1.80	95		0.86	>10		
1.98	6.5	15.98	5.54	3	Clay	CL/CH	stiff	125	1.3	13	1.76	95		0.82	>10		
2.13	7.0	17.88	5.80	3	Clay	CL/CH	very stiff	125	1.3	14	1.72	95		1.02	>10		
2.28	7.5	17.43	5.82	3	Clay	CL/CH	very stiff	125	1.3	14	1.68	95		1.00	>10		
2.45	8.0	12.74	5.21	3	Clay	CL/CH	stiff	125	1.3	10	1.85	100		0.73	>10		
2.60	8.5	15.87	5.45	3	Clay	CL/CH	stiff	125	1.3	13	1.82	95		0.80	>10		
2.75	9.0	14.88	4.88	3	Clay	CL/CH	stiff	125	1.3	12	1.59	95		0.86	>10		
2.90	9.5	12.84	4.10	3	Clay	CL/CH	stiff	125	1.3	10	1.56	95		0.72	>10		
3.05	10.0	17.88	4.85	3	Clay	CL/CH	very stiff	125	1.3	14	1.53	90		1.01	>10		
3.20	10.5	19.37	4.25	4	Silty Clay to Clay	CL	very stiff	125	1.8	11	1.50	80		1.11	>10		
3.35	11.0	35.91	2.83	6	Sandy Silt to Clayey Silt	ML	medium dense	115	3.5	10	1.48	50.3	55	52	35	1.88	>10
3.50	11.5	32.47	3.66	5	Clayey Silt to Silty Clay	ML/CL	very stiff	120	2.5	13	1.48	60		1.41	>10		
3.65	12.0	24.49	5.82	3	Clay	CL/CH	very stiff	125	1.3	20	1.44	85					
3.80	12.5	114.87	2.39	7	Silty Sand to Sandy Silt	SM/ML	dense	115	4.5	28	1.42	154.1	30	85	40		
3.95	13.0	118.08	2.08	7	Silty Sand to Sandy Silt	SM/ML	dense	115	4.5	28	1.40	157.7	25	86	40		
4.13	13.5	130.46	1.82	7	Silty Sand to Sandy Silt	SM/ML	dense	115	4.5	29	1.38	170.8	20	86	40		
4.28	14.0	71.38	3.53	6	Sandy Silt to Clayey Silt	ML	dense	115	3.5	20	1.37	92.3	45	70	38		
4.43	14.5	11.87	3.87	3	Clay	CL/CH	stiff	125	1.3	9	1.35	100		0.65	7.56		
4.58	15.0	13.07	4.55	3	Clay	CL/CH	stiff	125	1.3	10	1.33	100		0.73	8.85		
4.73	15.5	13.71	5.51	3	Clay	CL/CH	stiff	125	1.3	11	1.32	100		0.77	9.18		
4.88	16.0	15.52	5.99	3	Clay	CL/CH	stiff	125	1.3	12	1.30	100		0.88	>10		
5.03	16.5	13.80	6.69	3	Clay	CL/CH	stiff	125	1.3	11	1.28	100		0.77	8.41		
5.18	17.0	11.84	5.11	3	Clay	CL/CH	stiff	125	1.3	9	1.27	100		0.68	6.21		
5.33	17.5	17.82	6.52	3	Clay	CL/CH	stiff	125	1.3	14	1.25	100		1.00	>10		
5.48	18.0	20.74	5.85	3	Clay	CL/CH	very stiff	125	1.3	17	1.24	100		1.18	>10		
5.65	18.5	20.14	5.81	3	Clay	CL/CH	very stiff	125	1.3	16	1.23	100		1.14	>10		
5.80	19.0	18.14	5.32	3	Clay	CL/CH	very stiff	125	1.3	15	1.21	100		1.02	>10		
5.95	19.5	19.25	4.99	3	Clay	CL/CH	very stiff	125	1.3	15	1.20	100		1.09	>10		
6.10	20.0	30.88	3.32	5	Clayey Silt to Silty Clay	ML/CL	very stiff	120	2.5	12	1.18	75		1.76	>10		
6.25	20.5	37.41	2.39	6	Sandy Silt to Clayey Silt	ML	medium dense	115	3.5	11	1.18	41.8	60	47	35		
6.40	21.0	40.80	2.57	6	Sandy Silt to Clayey Silt	ML	medium dense	115	3.5	12	1.17	44.8	60	48	35		
6.55	21.5	18.20	4.88	3	Clay	CL/CH	stiff	125	1.3	13	1.16	100		0.91	7.70		
6.70	22.0	17.32	3.98	4	Silty Clay to Clay	CL	stiff	125	1.8	10	1.14	100		0.97	>10		
6.85	22.5	5.07	3.75	3	Clay	CL/CH	soft	125	1.3	4	1.13	100		0.25	1.25		
7.00	23.0	10.57	4.28	3	Clay	CL/CH	stiff	125	1.3	8	1.12	100		0.57	3.50		
7.18	23.5	13.03	5.31	3	Clay	CL/CH	stiff	125	1.3	10	1.11	100		0.72	4.68		
7.33	24.0	11.87	5.91	3	Clay	CL/CH	stiff	125	1.3	9	1.10	100		0.65	4.00		
7.48	24.5	18.97	6.88	3	Clay	CL/CH	very stiff	125	1.3	15	1.09	100		1.08	8.41		
7.63	25.0	22.75	6.61	3	Clay	CL/CH	very stiff	125	1.3	18	1.08	100		1.28	>10		
7.78	25.5	15.59	5.99	3	Clay	CL/CH	stiff	125	1.3	12	1.07	100		0.88	5.65		
7.93	26.0	25.11	5.45	3	Clay	CL/CH	very stiff	125	1.3	20	1.06	100		1.42	>10		
8.08	26.5	31.85	5.19	3	Clay	CL/CH	very stiff	125	1.3	26	1.06	95		1.82	>10		
8.23	27.0	33.38	5.02	3	Clay	CL/CH	very stiff	125	1.3	27	1.05	90		1.91	>10		
8.38	27.5	31.41	5.88	3	Clay	CL/CH	very stiff	125	1.3	25	1.04	100		1.78	>10		
8.53	28.0	19.92	7.34	3	Clay	CL/CH	very stiff	125	1.3	18	1.03	100		1.11	7.41		
8.68	28.5	12.49	5.94	3	Clay	CL/CH	stiff	125	1.3	10	1.02	100		0.88	3.43		
8.85	29.0	14.19	6.48	3	Clay	CL/CH	stiff	125	1.3	11	1.02	100		0.77	4.00		
8.90	29.5	18.80	6.63	3	Clay	CL/CH	stiff	125	1.3	13	1.01	100		0.93	5.21		
9.15	30.0	17.58	6.55	3	Clay	CL/CH	stiff	125	1.3	14	1.00	100		0.87	5.42		
9.30	30.5	16.27	6.22	3	Clay	CL/CH	stiff	125	1.3	13	0.99	100		0.89	4.88		

LANDMARK CONSULTANTS, INC.

CONE PENETROMETER INTERPRETATION (based on Robertson & Campanella, 1989, refer to Key to CPT logs)

Project: JR Simplot Fertilizer Terminal Project No: LE07435 Date: 11/19/07
 CONE SOUNDING: CPT-4

Base		Avg		1		Soil		Density or		Est. Qc		Phi Correlation		0		0-Schm(76)		1-R/C(83)		2-PHT(74)	
Depth	Depth	Tip	Friction	Soil	Soil	Density or	Density	to	SPT	or	Norm.	%	Rel.	Nk:	17.0	Est.	Rel.	Nk:	17.0	17.0	17.0
meters	feet	Qc, tsf	Ratio, %	Type	Classification	Consistency	(pcf)	N	N(60)	Cq	Qc	Qc	Qc	Qc	Qc	Fines	Dr (%)	(deg.)	(tsf)	(tsf)	OCR
8.45	31.0	17.25	6.85	3	Clay	CL/CH	stiff	125	1.3	14	0.99	100							0.95	5.00	
8.60	31.5	23.40	7.40	3	Clay	CL/CH	very stiff	125	1.3	18	0.98	100							1.31	8.27	
8.76	32.0	15.55	6.23	3	Clay	CL/CH	stiff	125	1.3	12	0.97	100							0.85	4.08	
8.90	32.5	16.49	5.73	3	Clay	CL/CH	stiff	125	1.3	13	0.98	100							0.90	4.37	
10.05	33.0	20.98	5.78	3	Clay	CL/CH	very stiff	125	1.3	18	0.98	100							1.13	6.00	
10.20	33.5	17.42	4.94	3	Clay	CL/CH	stiff	125	1.3	14	0.95	100							0.98	4.57	
10.36	34.0	13.53	5.72	3	Clay	CL/CH	stiff	125	1.3	11	0.95	100							0.73	3.14	
10.53	34.5	11.49	5.08	3	Clay	CL/CH	stiff	125	1.3	9	0.94	100							0.81	2.41	
10.68	35.0	19.01	6.81	3	Clay	CL/CH	very stiff	125	1.3	15	0.93	100							1.05	4.89	
10.83	35.5	22.13	6.73	3	Clay	CL/CH	very stiff	125	1.3	18	0.93	100							1.23	6.21	
10.98	36.0	26.02	6.08	3	Clay	CL/CH	very stiff	125	1.3	21	0.92	100							1.48	8.00	
11.13	36.5	31.14	5.37	3	Clay	CL/CH	very stiff	125	1.3	25	0.92	100							1.78	>10	
11.28	37.0	32.16	5.82	3	Clay	CL/CH	very stiff	125	1.3	28	0.91	100							1.82	>10	
11.43	37.5	29.10	4.28	4	Silty Clay to Clay	CL	very stiff	125	1.8	17	0.90	100							1.84	>10	
11.58	38.0	22.54	3.48	5	Clayey Silt to Silty Clay	ML/CL	very stiff	120	2.5	9	0.90	100							1.25	>10	
11.73	38.5	22.96	3.83	4	Silty Clay to Clay	CL	very stiff	125	1.8	13	0.89	100							1.27	7.70	
11.88	39.0	28.11	6.25	3	Clay	CL/CH	very stiff	125	1.3	22	0.89	100							1.57	8.14	
12.05	39.5	27.59	5.94	3	Clay	CL/CH	very stiff	125	1.3	22	0.88	100							1.64	7.70	
12.20	40.0	23.86	5.53	3	Clay	CL/CH	very stiff	125	1.3	19	0.88	100							1.32	5.88	
12.35	40.5	18.47	4.30	3	Clay	CL/CH	stiff	125	1.3	13	0.87	100							0.89	3.28	
12.50	41.0	35.43	3.36	5	Clayey Silt to Silty Clay	ML/CL	hard	120	2.5	14	0.87	90							2.00	>10	
12.65	41.5	36.20	3.67	5	Clayey Silt to Silty Clay	ML/CL	hard	120	2.5	14	0.86	95							2.06	>10	
12.80	42.0	24.40	4.14	4	Silty Clay to Clay	CL	very stiff	125	1.8	14	0.86	100							1.35	7.41	
12.95	42.5	25.12	3.00	5	Clayey Silt to Silty Clay	ML/CL	very stiff	120	2.5	10	0.86	100							1.39	>10	
13.10	43.0	12.17	2.75	5	Clayey Silt to Silty Clay	ML/CL	stiff	120	2.5	5	0.85	100							0.83	3.21	
13.25	43.5	14.80	3.20	4	Silty Clay to Clay	CL	stiff	125	1.8	8	0.85	100							0.77	3.14	
13.40	44.0	49.86	3.19	6	Sandy Silt to Clayey Silt	ML	medium dense	115	3.5	14	0.84	39.7	80	45	34						
13.58	44.5	77.87	1.88	7	Silty Sand to Sandy Silt	SM/ML	medium dense	115	4.5	17	0.84	81.6	55	58	36						
13.73	45.0	85.83	2.19	7	Silty Sand to Sandy Silt	SM/ML	medium dense	115	4.5	18	0.84	87.8	55	81	37						
13.88	45.5	188.81	2.32	7	Silty Sand to Sandy Silt	SM/ML	dense	115	4.5	41	0.83	146.8	35	84	40						
14.03	46.0	203.11	2.86	7	Silty Sand to Sandy Silt	SM/ML	dense	115	4.5	45	0.83	159.1	40	86	40						
14.18	46.5	118.70	2.37	7	Silty Sand to Sandy Silt	SM/ML	medium dense	115	4.5	26	0.82	91.0	50	70	38						
14.33	47.0	172.86	2.07	7	Silty Sand to Sandy Silt	SM/ML	dense	115	4.5	38	0.82	134.1	35	81	39						
14.48	47.5	168.80	2.10	7	Silty Sand to Sandy Silt	SM/ML	dense	115	4.5	37	0.82	129.0	40	80	38						
14.63	48.0	135.51	2.62	7	Silty Sand to Sandy Silt	SM/ML	dense	115	4.5	30	0.81	104.3	50	74	38						
14.78	48.5	104.37	2.16	7	Silty Sand to Sandy Silt	SM/ML	medium dense	115	4.5	23	0.81	80.0	50	66	37						
14.93	49.0	127.56	1.73	8	Sand to Silty Sand	SP/SM	dense	115	5.5	23	0.81	97.4	40	72	38						
15.10	49.5	136.38	2.02	7	Silty Sand to Sandy Silt	SM/ML	dense	115	4.5	30	0.80	103.7	40	74	38						
15.25	50.0	90.04	2.72	6	Sandy Silt to Clayey Silt	ML	medium dense	115	3.5	28	0.80	68.2	80	81	37						

DEPTH	FIELD				LOG OF BORING NO. 1 SHEET 1 OF 1	LABORATORY		
	SAMPLE	USCS CLASS.	BLOW COUNT	POCKET PEN. (tsf)		DESCRIPTION OF MATERIAL	DRY DENSITY (pcf)	MOISTURE CONTENT (% dry wt.)
5	●		12	1.5	SILTY CLAY (CL): Brown, very moist, stiff.			LL=43% PI=25%
10	▲		19		SILT (ML): Lt. brown, very moist, medium dense, some fine grained sand.		23.4	LL=29% PI= - %
15	▲		3		SILTY SAND (SM): Brown, saturated, very loose, fine grained sand.		26.9	Passing #200 = 39%
20	▲		12	3.5	CLAY (GH): Brown, very moist, firm to very stiff.	100.6	23.6	LL=54% PI=33%
25	▲		15	2.5				
30	▲		4	0.5				
35	▲		15	3.5				
40	▲		4	2.5				
45	▲		8	2.5				
50	▲		5	0.5	CLAYEY SILT/SILTY CLAY (ML/CL): Brown, very moist, loose/firm.			
55	▲		8		SANDY SILT (ML): Brown, saturated, loose, fine grained sand.			Passing #200 = 58%
60	▲		10		CLAYEY SILT/SANDY SILT (ML): Brown, saturated, medium dense fine grained sand.		31.5	LL=28% PI= - %
60					Total Depth = 51.5' Backfilled with excavated soil			

DATE DRILLED: 11/20/07	TOTAL DEPTH: 51.5 Feet	DEPTH TO WATER: +/- 5 ft.
LOGGED BY: J. Avalos	TYPE OF BIT: Hollow Stem Auger	DIAMETER: 8 in.
SURFACE ELEVATION: Approximately -78'	HAMMER WT.: 140 lbs.	DROP: 30 in.

PROJECT NO. LE07435	LANDMARK <small>Engineering and Construction</small>	PLATE B-5
---------------------	--	-----------

DEPTH	FIELD				LOG OF BORING NO. 2 SHEET 1 OF 1	LABORATORY		
	SAMPLE	USCS CLASS.	BLOW COUNT	POCKET PEN. (tsf)	DESCRIPTION OF MATERIAL	DRY DENSITY (pcf)	MOISTURE CONTENT (% dry wt.)	OTHER TESTS
5	█	█	3	1.5	SILTY CLAY (CL): Brown, very moist, stiff to very stiff.	96.4	29.0	LL=42% PI=25%
10	█	█	11	3.0				Su = 1.55 c=0.77
15	█	█	13		SANDY SILT (ML): Lt. brown, very moist, medium dense, some fine grained sand.	96.8	29.3	Passing #200 = 59%
20	█	█	7	2.5	SILTY CLAY (CL): Brown, very moist, stiff to very stiff.			LL=29% PI= - %
25	█	█	10		CLAYEY SILT/SILT (ML): Brown, saturated, very loose, some fine grained sand.			
30	█	█	5	2.5	CLAY (CH): Brown, very moist, firm to very stiff.			
35	█	█	6	2.0				
40								
45								
50								
55								
60					Total Depth = 31.5' Backfilled with excavated soil			

DATE DRILLED: 11/20/07	TOTAL DEPTH: 31.5 Feet	DEPTH TO WATER: +/- 5 ft.
LOGGED BY: J. Avalos	TYPE OF BIT: Hollow Stem Auger	DIAMETER: 8 in.
SURFACE ELEVATION: Approximately -78'	HAMMER WT.: 140 lbs.	DROP: 30 in.

PROJECT NO. LE07435	LANDMARK <small>Geotechnical Engineering & Construction</small>	PLATE B-6
---------------------	---	-----------

DEPTH	FIELD				LOG OF BORING NO. 3 SHEET 1 OF 1		LABORATORY		
	SAMPLE	USCS CLASS.	BLOW COUNT	POCKET PEN. (tsf)	DESCRIPTION OF MATERIAL	DRY DENSITY (pcf)	MOISTURE CONTENT (% dry wt.)	OTHER TESTS	
5	●	[Hatched Pattern]	5	0.5	CLAY (CH): Brown, very moist, firm to very stiff.	94.5	28.0	LL=60% PI=24%	
10	▲		11	2.5				Su = 1.27 c=0.64	
15	▲		3					LL=54% PI=32%	
20	▲		12	1.0		98.7	28.5		
25	▲		7	1.5					
30	▲		6	1.0					
35									
40									
45									
50									
55									
60									
					Total Depth = 31.5' Backfilled with excavated soil				
DATE DRILLED: 11/20/07		TOTAL DEPTH: 31.5 Feet		DEPTH TO WATER: +/- 5 ft.					
LOGGED BY: J. Avalos		TYPE OF BIT: Hollow Stem Auger		DIAMETER: 8 in.					
SURFACE ELEVATION: Approximately -78'		HAMMER WT.: 140 lbs.		DROP: 30 in.					
PROJECT NO. LE07435						PLATE B-7			

DEPTH	FIELD				LOG OF BORING NO. 4 SHEET 1 OF 1	LABORATORY			
	SAMPLE	USCS CLASS.	BLOW COUNT	POCKET PEN. (tsf)	DESCRIPTION OF MATERIAL	DRY DENSITY (pcf)	MOISTURE CONTENT (% dry wt.)	OTHER TESTS	
5	●	▨			SILTY CLAY (CL): Brown, very moist, stiff to very stiff.				
10									
15									
20									
25									
30									
35									
40									
45									
50									
55									
80					Total Depth = 5.0' Backfilled with excavated soil				
DATE DRILLED: 11/20/07		TOTAL DEPTH: 5.0 Feet		DEPTH TO WATER: +/- 5 ft.					
LOGGED BY: J. Avalos		TYPE OF BIT: Hollow Stem Auger		DIAMETER: 8 in.					
SURFACE ELEVATION: Approximately -78'		HAMMER WT.: 140 lbs.		DROP: 30 in.					
PROJECT NO. LE07435				LANDMARK <small>Engineering & Construction</small>				PLATE B-8	

DEPTH	FIELD				LOG OF BORING NO. 5 SHEET 1 OF 1	LABORATORY			
	SAMPLE	USCS CLASS	BLOW COUNT	POCKET PEN. (tsf)		DESCRIPTION OF MATERIAL	DRY DENSITY (pcf)	MOISTURE CONTENT (% dry wt.)	OTHER TESTS
5					SILTY CLAY (CL): Brown, very moist, stiff to very stiff.			R-Value = 6	
10									
15									
20									
25									
30									
35									
40									
45									
50									
55									
60					Total Depth = 5.0' Backfilled with excavated soil				
DATE DRILLED: 11/20/07		TOTAL DEPTH: 5.0 Feet		DEPTH TO WATER: +/- 5 ft.					
LOGGED BY: J. Avalos		TYPE OF BIT: Hollow Stem Auger		DIAMETER: 8 in.					
SURFACE ELEVATION: Approximately -78'		HAMMER WT.: 140 lbs.		DROP: 30 in.					
PROJECT NO. LE07435				LANDMARK <small>Soils, Foundations and Geotechnical</small>				PLATE B-9	

DEPTH	FIELD				LOG OF BORING NO. 6 SHEET 1 OF 1	LABORATORY		
	SAMPLE	USCS CLASS.	BLOW COUNT	POCKET PEN. (blf)		DESCRIPTION OF MATERIAL	DRY DENSITY (pcf)	MOISTURE CONTENT (% dry wt.)
5	●	▨			SILTY CLAY (CL): Brown, very moist, stiff to very stiff.			
10								
15								
20								
25								
30								
35								
40								
45								
50								
55					Total Depth = 5.0' Backfilled with excavated soil			
60								
DATE DRILLED: 11/20/07		TOTAL DEPTH: 5.0 Feet		DEPTH TO WATER: +/- 5 ft.				
LOGGED BY: J. Avalos		TYPE OF BIT: Hollow Stem Auger		DIAMETER: 8 in.				
SURFACE ELEVATION: Approximately -78'		HAMMER WT.: 140 lbs.		DROP: 30 in.				
PROJECT NO. LE07435						PLATE B-10		

DEPTH	FIELD				LOG OF BORING NO. 7 SHEET 1 OF 1	LABORATORY		
	SAMPLE	USCS CLASS.	BLOW COUNT	POCKET PEN. (tsf)	DESCRIPTION OF MATERIAL	DRY DENSITY (pcf)	MOISTURE CONTENT (% dry wt.)	OTHER TESTS
5	●	▨			SILTY CLAY (CL): Brown, very moist, stiff to very stiff.			
10								
15								
20								
25								
30								
35								
40								
45								
50								
55								
60					Total Depth = 5.0' Backfilled with excavated soil			
DATE DRILLED: 11/20/07		TOTAL DEPTH: 5.0 Feet		DEPTH TO WATER: +/- 5 ft.				
LOGGED BY: J. Avalos		TYPE OF BIT: Hollow Stem Auger		DIAMETER: 8 in.				
SURFACE ELEVATION: Approximately -78'		HAMMER WT.: 140 lbs.		DROP: 30 in.				
PROJECT NO. LE07435				LANDMARK <small>Geotechnical Engineering & Construction</small>		PLATE B-11		

DEPTH	FIELD				LOG OF BORING NO. 8 SHEET 1 OF 1		LABORATORY		
	SAMPLE	USCS CLASS.	BLOW COUNT	POCKET PEN. (tsf)	DESCRIPTION OF MATERIAL	DRY DENSITY (pcf)	MOISTURE CONTENT (% dry wt.)	OTHER TESTS	
5	●	▨			SILTY CLAY (CL): Brown, very moist, stiff to very stiff.			R-Value = 9	
10									
15									
20									
25									
30									
35									
40									
45									
50									
55									
60					Total Depth = 5.0' Backfilled with excavated soil				
DATE DRILLED:		11/20/07		TOTAL DEPTH:		5.0 Feet		DEPTH TO WATER: +/- 5 ft.	
LOGGED BY:		J. Avalos		TYPE OF BIT:		Hollow Stem Auger		DIAMETER: 8 in.	
SURFACE ELEVATION:		Approximately -78'		HAMMER WT.:		140 lbs.		DROP: 30 in.	
PROJECT NO. LE07435				LANDMARK <small>Geotechnical Engineering</small>				PLATE B-12	

Simplified Soil Classification Chart
After Robertson & Campanella (1989)

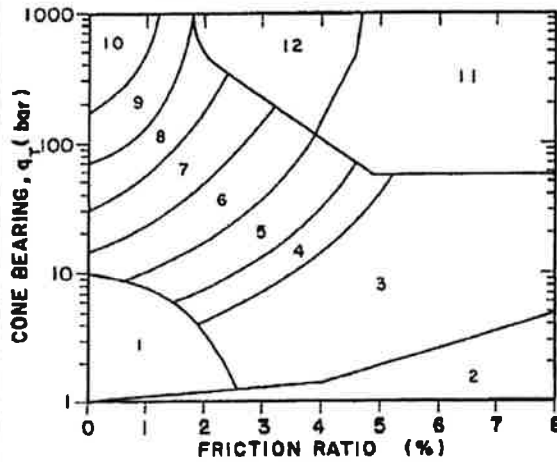

Geotechnical Parameters from CPT Data:

Equivalent SPT N(60) blow count = $Q_c / (Q_c/N \text{ Ratio})$
 $N1(60) = C_n \cdot N(60)$ Normalized SPT blow count
 $C_n = 1 / (p'_{o'})^{0.5} < 1.6$ max. from Liao & Whitman (1986)
 $p'_{o'}$ = effective overburden pressure (tsf) using unit densities given below and estimated groundwater table.
 Dr = Relative density (%) from Jamiolkowski et. al. (1986) relationship
 $= -98 + 68 \cdot \log(Q_c / p'_{o'})^{0.5}$ where $Q_c, p'_{o'}$ in tonne/sqm
 Note: 1 tonne/sqm = 0.1024 tsf, 1 bar = 1.0443 tsf
Phi = Friction Angle estimated from either:
 1. Robertson & Campanella (1983) chart:
 $\Phi = 5.3 + 24 \cdot (\log(Q_c / p'_{o'})) + 3 \cdot (\log(Q_c / p'_{o'}))^2$
 2. Peck, Hansen & Thornburn (1974) N-Phi Correlation
 3. Schmertman (1978) chart [$\Phi = 28 + 0.14 \cdot Dr$ for fine uniform sands]
Su = undrained shear strength (tsf)
 $= (Q_c - p'_{o'}) / N_k$ where N_k varies from 10 to 22, 17 for OC clays
 OCR = Overconsolidation Ratio estimated from Schmertman (1978) chart using $S_u / p'_{o'}$ ratio and estimated normal consolidated $S_u / p'_{o'}$

Variation of Q_c/N Ratio with Grain Size

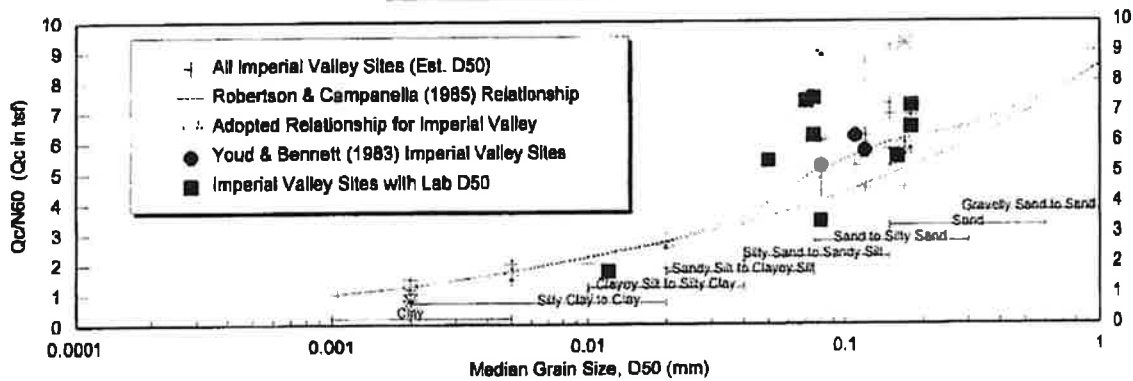

Note: Assumed Properties and Adopted Q_c/N Ratio based on correlations from Imperial Valley, California soils

Table of Soil Types and Assumed Properties

Zone	Soil Classification	UCS	Density (pcf)	R&C Q_c/N	Adopted Q_c/N	Est. PI	Fines (%)	D50 (mm)	S_u (tsf)	Consistency
1	Sensitive fine grained	ML	120	2	2	NP-15	65-100	0.020	0-0.13	very soft
2	Organic Material	OL/OH	120	1	1	--	--	--	0.13-.25	soft
3	Clay	CL/CH	125	1	1.25	25-40+	90-100	0.002	0.25-0.5	firm
4	Silty Clay to Clay	CL	125	1.5	2	15-40	90-100	0.010	0.5-1.0	stiff
5	Clayey Silt to Silty Clay	ML/CL	120	2	2.75	5-25	90-100	0.020	1.0-2.0	very stiff
6	Sandy Silt to Clayey Silt	ML	115	2.5	3.5	NP-10	65-100	0.040	>2.0	hard
7	Silty Sand to Sandy Silt	SM/ML	115	3	5	NP	35-75	0.075	Dr (%)	Relative Density
8	Sand to Silty Sand	SP/SM	115	4	6	NP	5-35	0.150	0-15	very loose
9	Sand	SP	110	5	6.5	NP	0-5	0.300	15-35	loose
10	Gravelly Sand to Sand	SW	115	6	7.5	NP	0-5	0.600	35-65	medium dense
11	Overconsolidated Soil	--	120	1	1	NP	90-100	0.010	65-85	dense
12	Sand to Clayey Sand	SP/SC	115	2	2	NP-5	--	--	>85	very dense

LANDMARK
Geo-Engineers and Geologists

Project No: LE07435

Key to CPT Interpretation of Logs

Plate
B-13

DEFINITION OF TERMS

PRIMARY DIVISIONS	SYMBOLS	SECONDARY DIVISIONS
Coarse grained soils More than half of coarse fraction is larger than No. 4 sieve More than half of material is larger than No. 200 sieve	Gravels Clean gravels (less than 5% fines)	GW Well graded gravels, gravel-sand mixtures, little or no fines GP Poorly graded gravels, or gravel-sand mixtures, little or no fines
	Gravel with fines	GM Silty gravels, gravel-sand-silt mixtures, non-plastic fines GC Clayey gravels, gravel-sand-clay mixtures, plastic fines
	Sands Clean sands (less than 5% fines)	SW Well graded sands, gravelly sands, little or no fines SP Poorly graded sands or gravelly sands, little or no fines
	Sands with fines	SM Silty sands, sand-silt mixtures, non-plastic fines SC Clayey sands, sand-clay mixtures, plastic fines
	Silts and clays Liquid limit is less than 50%	ML Inorganic silts, clayey silts with slight plasticity CL Inorganic clays of low to medium plasticity, gravelly, sandy, or lean clays OL Organic silts and organic clays of low plasticity
	Silts and clays Liquid limit is more than 50%	MH Inorganic silts, micaceous or diatomaceous silty soils, elastic silts CH Inorganic clays of high plasticity, fat clays OH Organic clays of medium to high plasticity, organic silts
Highly organic soils	PT Peat and other highly organic soils	

GRAIN SIZES

Silt and Clays	Sand	Gravel	Cobbles	Boulders
	Fine Medium Coarse	Fine Coarse		
	200 4 10 4	3/4" 3" 12"		
	US Standard Series Sieve		Clear Square Openings	

<table style="width: 100%; border-collapse: collapse;"> <thead> <tr> <th>Sands, Gravels, etc.</th> <th>Blows/ft. *</th> </tr> </thead> <tbody> <tr><td>Very Loose</td><td>0-4</td></tr> <tr><td>Loose</td><td>4-10</td></tr> <tr><td>Medium Dense</td><td>10-30</td></tr> <tr><td>Dense</td><td>30-50</td></tr> <tr><td>Very Dense</td><td>Over 50</td></tr> </tbody> </table>	Sands, Gravels, etc.	Blows/ft. *	Very Loose	0-4	Loose	4-10	Medium Dense	10-30	Dense	30-50	Very Dense	Over 50	<table style="width: 100%; border-collapse: collapse;"> <thead> <tr> <th>Clays & Plastic Silts</th> <th>Strength **</th> <th>Blows/ft. *</th> </tr> </thead> <tbody> <tr><td>Very Soft</td><td>0-0.25</td><td>0-2</td></tr> <tr><td>Soft</td><td>0.25-0.5</td><td>2-4</td></tr> <tr><td>Firm</td><td>0.5-1.0</td><td>4-8</td></tr> <tr><td>Stiff</td><td>1.0-2.0</td><td>8-16</td></tr> <tr><td>Very Stiff</td><td>2.0-4.0</td><td>16-32</td></tr> <tr><td>Hard</td><td>Over 4.0</td><td>Over 32</td></tr> </tbody> </table>	Clays & Plastic Silts	Strength **	Blows/ft. *	Very Soft	0-0.25	0-2	Soft	0.25-0.5	2-4	Firm	0.5-1.0	4-8	Stiff	1.0-2.0	8-16	Very Stiff	2.0-4.0	16-32	Hard	Over 4.0	Over 32
Sands, Gravels, etc.	Blows/ft. *																																	
Very Loose	0-4																																	
Loose	4-10																																	
Medium Dense	10-30																																	
Dense	30-50																																	
Very Dense	Over 50																																	
Clays & Plastic Silts	Strength **	Blows/ft. *																																
Very Soft	0-0.25	0-2																																
Soft	0.25-0.5	2-4																																
Firm	0.5-1.0	4-8																																
Stiff	1.0-2.0	8-16																																
Very Stiff	2.0-4.0	16-32																																
Hard	Over 4.0	Over 32																																

* Number of blows of 140 lb. hammer falling 30 inches to drive a 2 inch O.D. (1 3/8 in. I.D.) split spoon (ASTM D1586).

** Unconfined compressive strength in tons/s.f. as determined by laboratory testing or approximated by the Standard Penetration Test (ASTM D1586), Pocket Penetrometer, Torvane, or visual observation.

Type of Samples: Ring Sample Standard Penetration Test Shelby Tube Bulk (Bag) Sample

Drilling Notes:

1. Sampling and Blow Counts
 - Ring Sampler - Number of blows per foot of a 140 lb. hammer falling 30 inches.
 - Standard Penetration Test - Number of blows per foot.
 - Shelby Tube - Three (3) inch nominal diameter tube hydraulically pushed.
2. P. P. = Pocket Penetrometer (tons/s f.).
3. NR = No recovery.
4. GWT = Ground Water Table observed @ specified time.

Project No: LE07435

Key to Logs

Plate B-14

APPENDIX C

LANDMARK CONSULTANTS, INC.

CLIENT: DD&E
PROJECT: JR Simplot Fertilizer Terminal
JOB NO: LE07435
DATE: 11/28/07

ATTERBERG LIMITS (ASTM D4318)

Sample Location	Sample Depth (ft)	Liquid Limit (LL)	Plastic Limit (PL)	Plasticity Index (PI)	USCS Classification
B-1	0-5	43	18	25	CL
B-1	10	29	--	--	ML
B-1	30	54	21	33	CH
B-1	50	28	--	--	ML
B-2	0-2.5	42	17	25	CL
B-2	20	29	--	--	ML
B-3	0-5	50	26	24	CL-CH
B-3	15	54	22	32	CH

PLASTICITY CHART

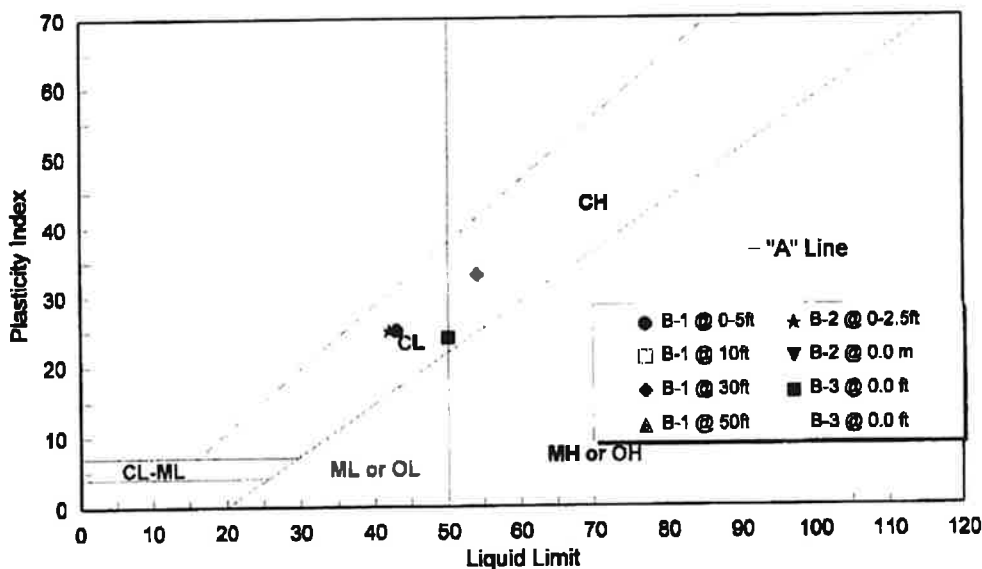

LANDMARK
Geotechnical and Geology

Project No: LE07435

**Atterberg Limits
 Test Results**

**Plate
 C-1**

SOUTHLAND GEOTECHNICAL

CLIENT: DD&E
PROJECT: JR Simplot Fertilizer Terminal
JOB NO: LE07435
DATE: 11/28/07

UNCONFINED COMPRESSION TEST (ASTM D2166)

Boring No.	Sample Depth (ft)	Natural Moisture Content (%)	Unit Dry Weight (pcf)	Maximum Compressive Strength (tsf)	Cohesion (tsf)	Failure Strain (%)
B-2	7.5	29.0	95.4	1.55	0.77	7.8
B-3	10.0	28.0	94.5	1.27	0.64	9.3

STRESS-STRAIN PLOT

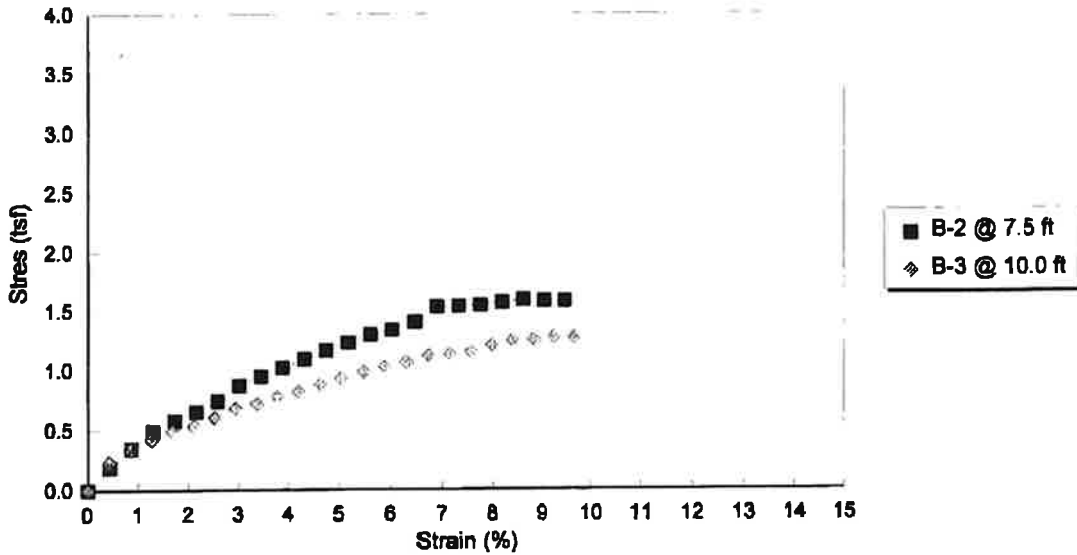

Project No: LE07435

**Unconfined Compression
Test Results**

**Plate
C-2**

LANDMARK CONSULTANTS, INC.

CLIENT: DD&E
PROJECT: JR Simplot Fertilizer Terminal
JOB NO: LE07435
DATE: 11/28/07

CHEMICAL ANALYSES

	Boring: B-1	B-2	B-3	CalTrans Method
Sample Depth, ft:	0-5	0-2.5	0-5	
pH:	7.4	7.7	7.4	643
Electrical Conductivity (mmhos):	1.9	3.7	1.5	424
Resistivity (ohm-cm):	440	170	410	643
Chloride (Cl), ppm:	720	4,480	1,490	422
Sulfate (SO ₄), ppm:	1,478	3,831	848	417

General Guidelines for Soil Corrosivity

Material Affected	Chemical Agent	Amount in Soil (ppm)	Degree of Corrosivity
Concrete	Soluble Sulfates	0 -1000	Low
		1000 - 2000	Moderate
		2000 - 20,000	Severe
		> 20,000	Very Severe
Normal Grade Steel	Soluble Chlorides	0 - 200	Low
		200 - 700	Moderate
		700 - 1500	Severe
		> 1500	Very Severe
Normal Grade Steel	Resistivity	1-1000	Very Severe
		1000-2000	Severe
		2000-10,000	Moderate
		10,000+	Low

LANDMARK
 Geo Engineers and Geologists

Project No: LE07435

**Selected Chemical
 Analyses Results**

**Plate
 C-3**

SIEVE ANALYSIS					HYDROMETER ANALYSIS
Gravel		Sand			Silt and Clay Fraction
Coarse	Fine	Coarse	Medium	Fine	

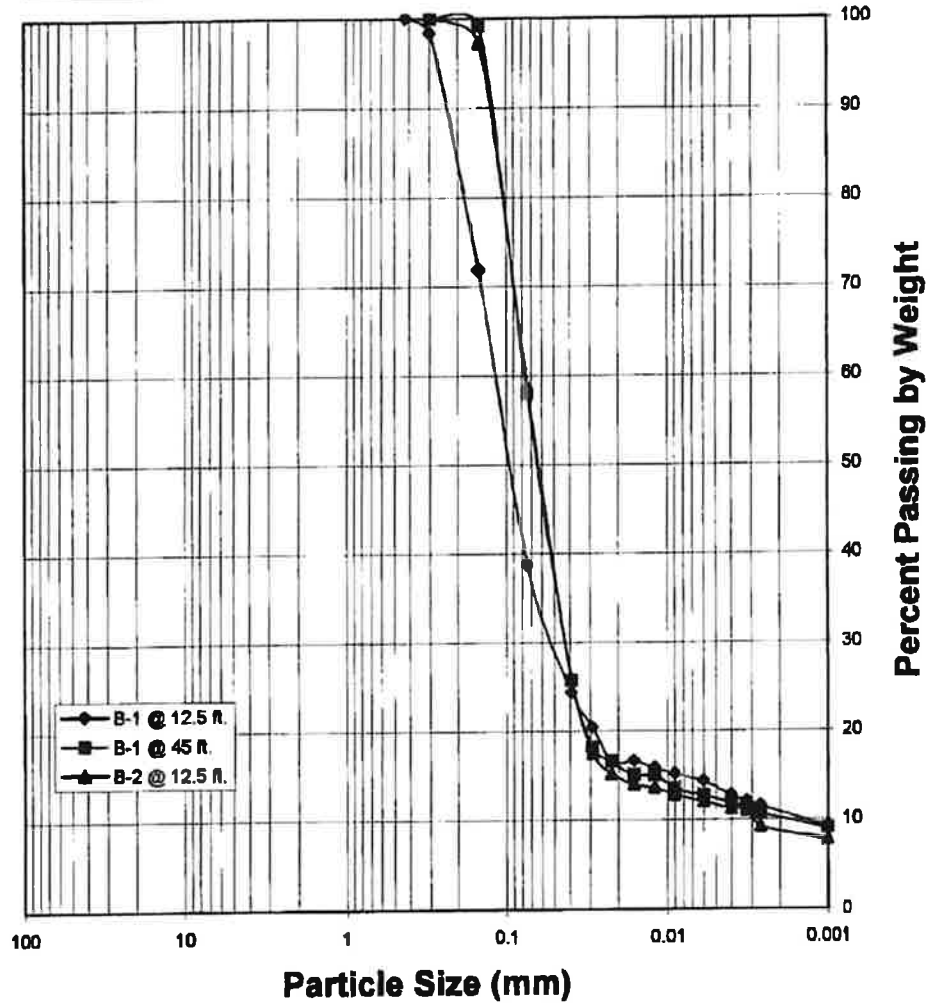

LANDMARK
Geo Engineers and Geologists

Project No.: LE07435

Grain Size Analysis

Plate
C-4

LANDMARK

CLIENT: DD&E
PROJECT: JR Simplot Fertilizer Terminal
JOB NO: LE07435
DATE: 12/05/07

R VALUE TEST (CAL TEST 301)

SAMPLE DESCRIPTION: Clay (CL-CH)
SAMPLE LOCATION: B-5 @0-5'

Specimen ID:	A	B	C
Moisture Content, %:	18.7%	19.6%	20.5%
Dry Density, pcf:	107.7	106.3	106.0
Compaction foot pressure, psi:	100	80	60
Specimen Height, in.:	2.55	2.47	2.46
Stabilometer, Ph @ 1000 lb:	66	72	80
Stabilometer, Ph @ 2000 lb:	140	144	144
Displacement:	3.92	3.98	4.5
Expansion pressure, psf:	92	83	79
Exudation pressure, psi:	491	403	221
Equilibrium R Value:	8	7	6
R Value at 300 psi:		6	

EXUDATION PRESSURE CHART

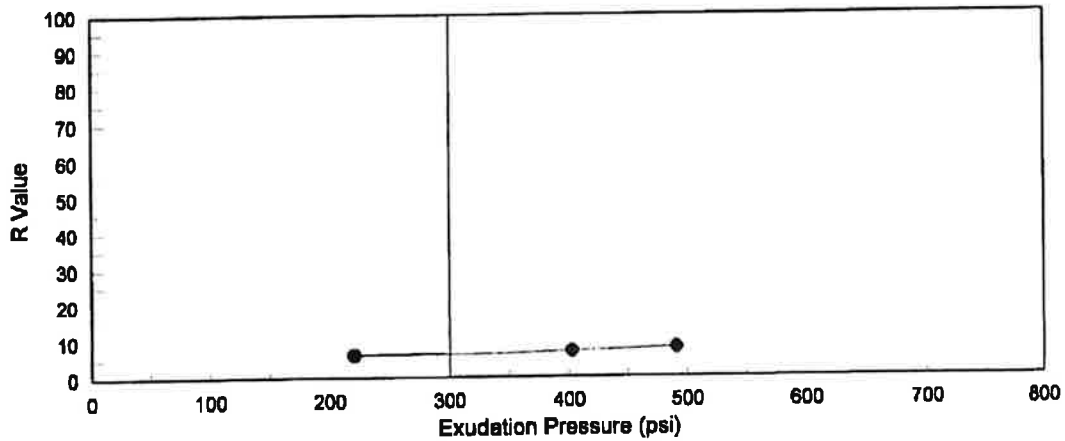

LANDMARK
Geotechnical and Geology

Project No: LE07435

**R Value
Test Results**

**Plate
C-5**

LANDMARK

CLIENT: DD&E
PROJECT: JR Simplot Fertilizer Terminal
JOB NO: LE07435
DATE: 12/05/07

R VALUE TEST (CAL TEST 301)

SAMPLE DESCRIPTION: Silty Clay (CL)
SAMPLE LOCATION: B-8 @0-5'

Specimen ID:	A	B	C
Moisture Content, %:	16.4%	15.5%	14.6%
Dry Density, pcf:	112.8	114.3	117.1
Compaction foot pressure, psi:	100	150	250
Specimen Height, in.:	2.49	2.52	2.46
Stabilometer, Ph @ 1000 lb:	70	62	58
Stabilometer, Ph @ 2000 lb:	144	136	116
Displacement:	4.15	3.76	3.73
Expansion pressure, psf:	52	74	87
Exudation pressure, psi:	216	327	425
Equilibrium R Value:	6	11	20
R Value at 300 psi:		9	

EXUDATION PRESSURE CHART

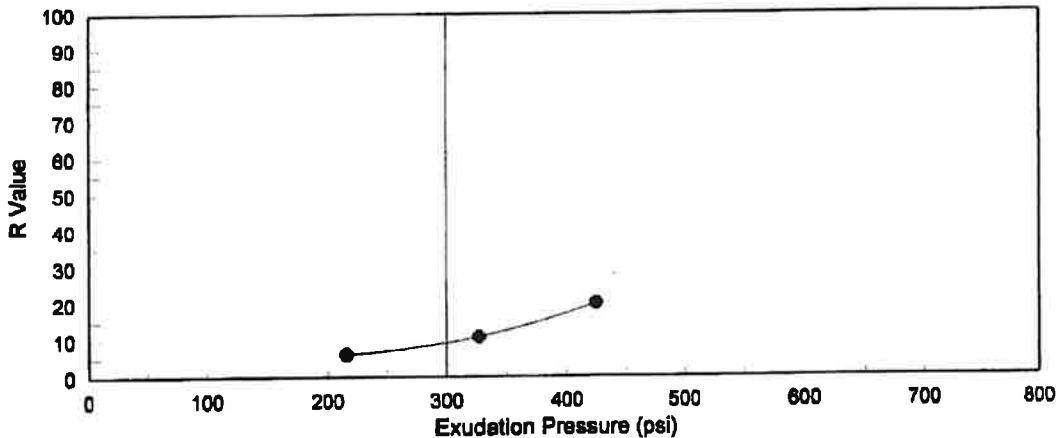

LANDMARK
Geo-Engineers and Geologists

Project No: LE07435

R Value
Test Results

Plate
C-6

ONE DIMENSIONAL CONSOLIDATION TEST (ASTM D2435)

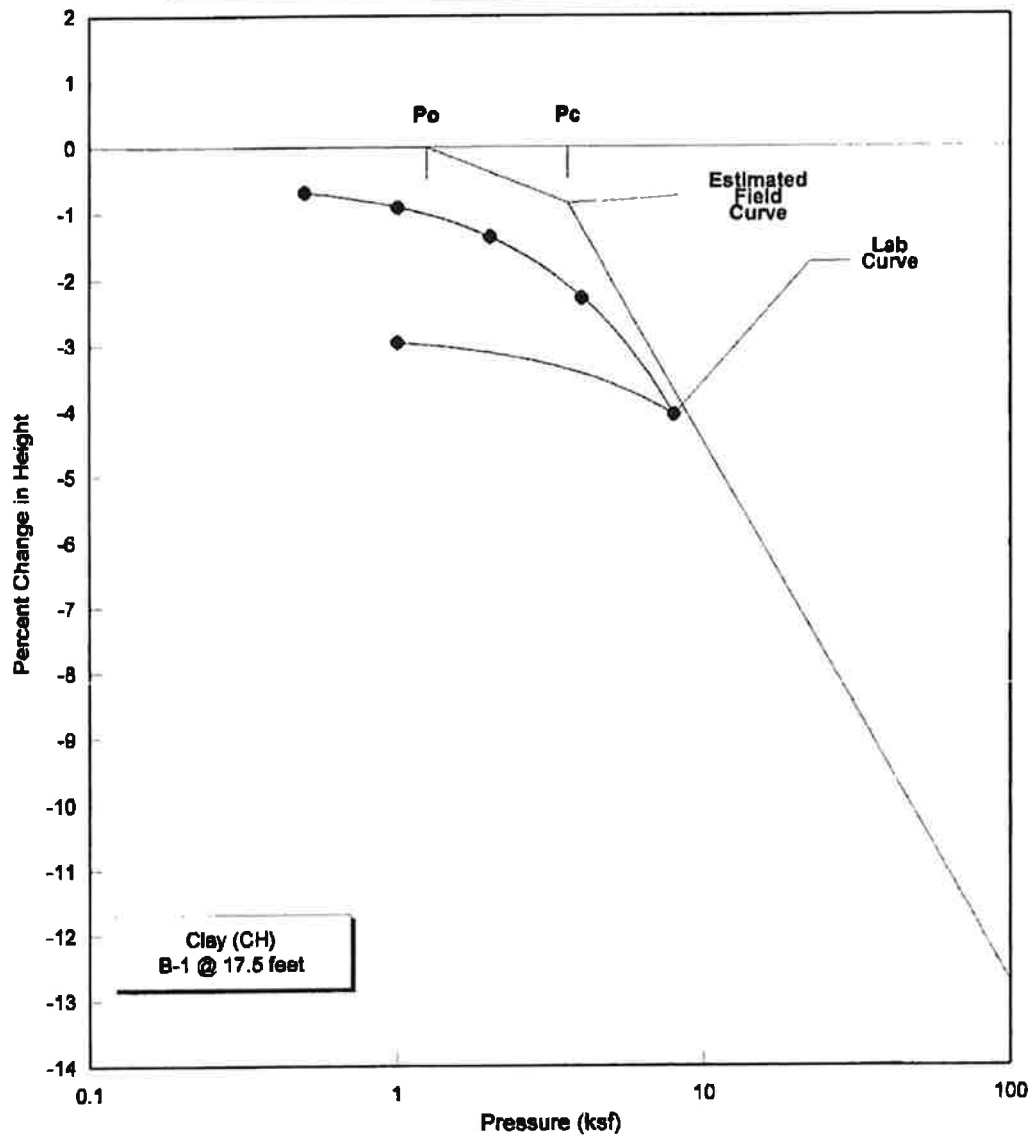

Results of Test:		Initial	Final
Overburden Pressure, Po:	1.2 ksf	Dry Density, pcf: 78.8	81.2
Preconsol. Pressure, Pc:	3.6 ksf	Water Content, %:	23.5 39.8
Compression Index, Cc:	0.176	Void Ratio, e:	1.138 1.075
Recompression. Index, Cr:	0.039	Saturation, %:	55.8 100.0

LANDMARK
Geo-Engineering and Construction
a MBE Company

Project No: LE07435

**Consolidation
Test Results**

**Plate
C-7**

ONE DIMENSIONAL CONSOLIDATION TEST (ASTM D2435)

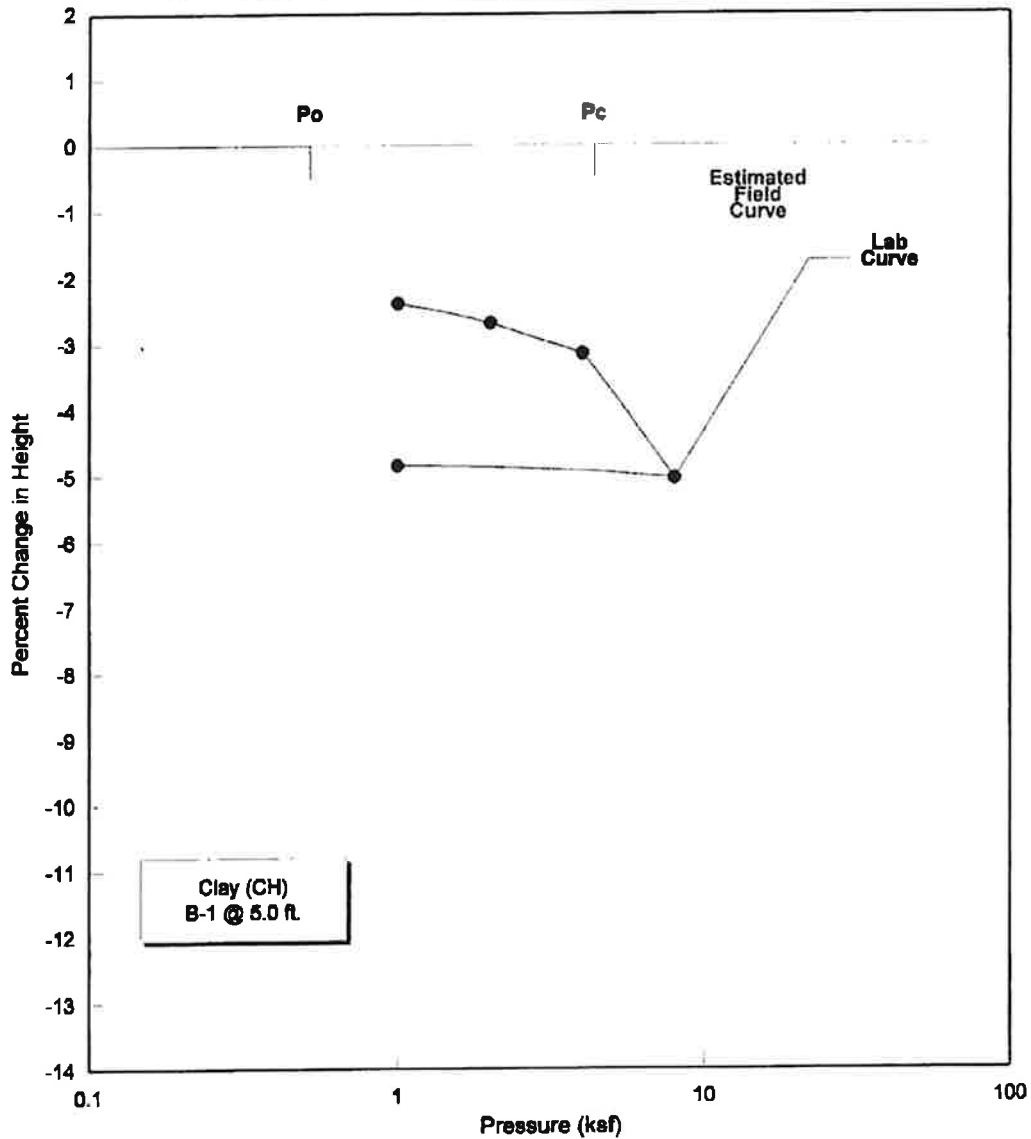

Clay (CH)
B-1 @ 5.0 ft.

Results of Test:		Initial	Final
Overburden Pressure, Po:	0.5 ksf	Dry Density, pcf: 80.9	85.0
Preconsol. Pressure, Pc:	4.3 ksf	Water Content, %:	27.6 36.4
Compression Index, Cc:	NA	Void Ratio, e:	1.083 0.982
Recompression. Index, Cr:	NA	Saturation, %:	68.7 100.0

<p>LANDMARK Geotechnical and Geology, Inc.</p> <p>Project No: LE07435</p>	<p align="center">Consolidation Test Results</p>	<p align="center">Plate C-8</p>
--	---	--

APPENDIX D

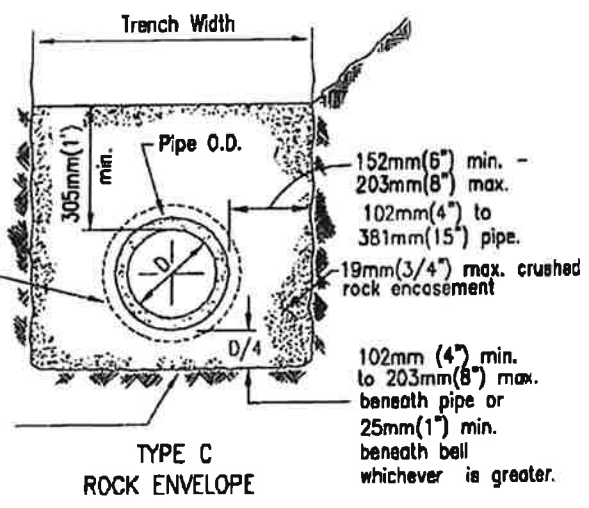
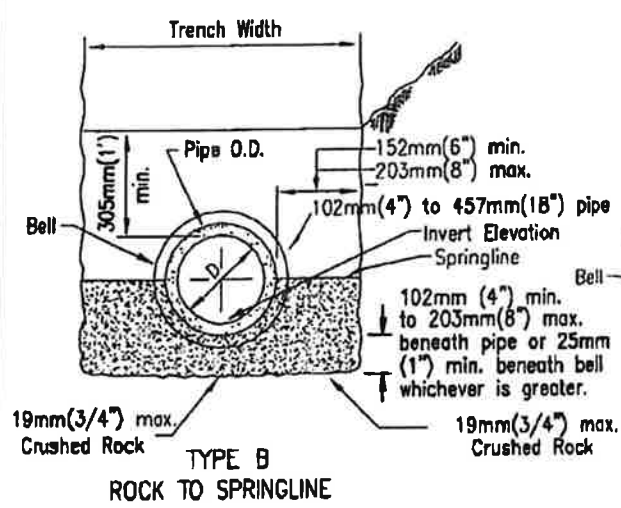
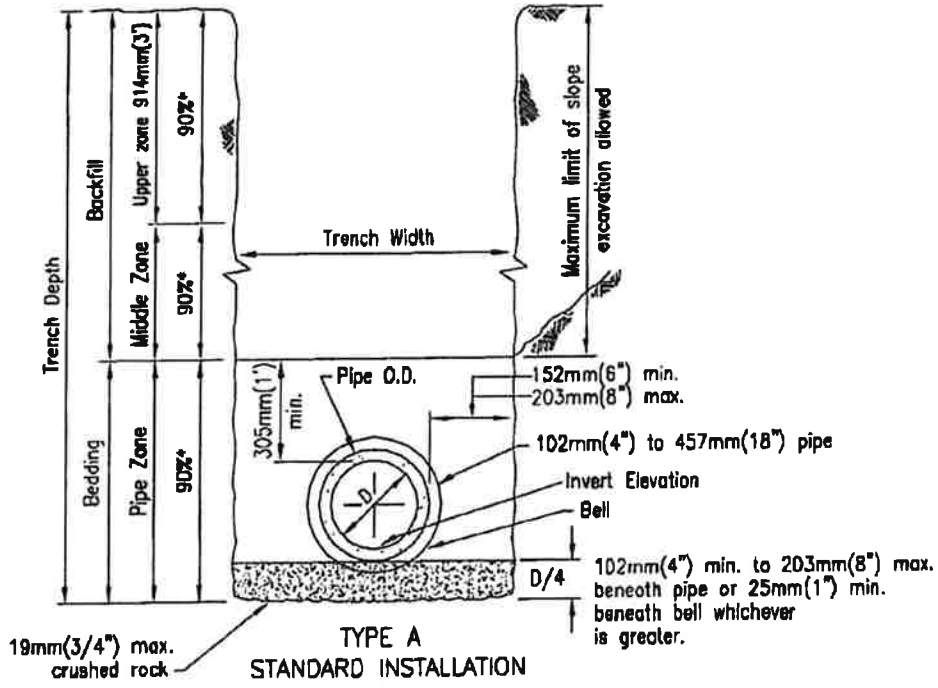

- NOTES**
1. For trenching in improved streets, see Standard Drawings G-24 or G-25 for trench resurfacing.
 2. (*) indicates minimum relative compaction.
 3. Minimum depth of cover from the top of pipe to finish grade for all sanitary sewer installations shall be 914mm(3') For cover less than 914mm(3'), see Standard Drawing S-7 for concrete encasement.
 4. See Type A installation for details not shown for Types B and C.

Revision	By	Approved	Date	SAN DIEGO REGIONAL STANDARD DRAWING	RECOMMENDED BY THE SAN DIEGO REGIONAL STANDARDS COMMITTEE
ORIGINAL		A.Kercheval	12/75		PIPE BEDDING AND TRENCH BACKFILL FOR SEWERS
Add Metric		T. Stanton	03/03	Chairperson R.C.E. 19245 Date	
				DRAWING NUMBER	
				S-4	

APPENDIX E

REFERENCES

- American Society of Civil Engineers (ASCE), 2005, Minimum Design Loads for Buildings and Other Structures: ASCE Standard 7-05.
- Arango I., 1996, Magnitude Scaling Factors for Soil Liquefaction Evaluations: ASCE Geotechnical Journal, Vol. 122, No. 11.
- Blake, T. F., 2000, FRISKSP - A computer program for the probabilistic estimation of seismic hazard using faults as earthquake sources.
- Boore, D. M., Joyner, W. B., and Fumal, T. E., 1997, Empirical Near-Source Attenuation Relationships for Horizontal and Vertical Components of Peak Ground Acceleration, Peak Ground Velocity, and Pseudo-Absolute Acceleration Response Spectra: Seismological Research Letters, Vol. 68, No. 1, p. 154-179.
- Bray, J. D., Sancio, R. B., Riemer, M. F. and Durgunoglu, T., (2004), Liquefaction Susceptibility of Fine-Grained Soils: Proc. 11th Inter. Conf. in Soil Dynamics and Earthquake Engineering and 3rd Inter. Conf. on Earthquake Geotechnical Engineering., Doolin, Kammerer, Nogami, Seed, and Towhata, Eds., Berkeley, CA, Jan. 7-9, V.1, pp. 655-662.
- California Building Standards Commission, 2007, 2007 California Building Code. California Code of Regulations, Title 24, Part 2, Vol. 2 of 2.
- California Division of Mines and Geology (CDMG), 1996, California Fault Parameters: available at <http://www.consrv.ca.gov/dmg/shezp/fltindex.html>.
- California Division of Mines and Geology (CDMG), 1962, Geologic Map of California - San Diego-El Centro Sheet: California Division of Mines and Geology, Scale 1:250,000.
- Cao, T., Bryant, W. A., Rowshandel, B., Branum, D., and Wills, C. J., 2003, The revised 2002 California probabilistic seismic hazards maps: California Geological Survey: <http://www.conservation.ca.gov/cgs/rghm/psha>.
- Cetin, K. O., Seed, R. B., Der Kiureghian, A., Tokimatsu, K., Harder, L. F., Jr., Kayen, R. E., and Moss, R. E. S., 2004, Standard penetration test-based probabilistic and deterministic assessment of seismic soil liquefaction potential: ASCE JGGE, Vol., 130, No. 12, p. 1314-1340.
- Dibblee, T. W., 1954, Geology of the Imperial Valley region, California, in: Jahns, R. H., ed., Geology of Southern California: California Division of Mines Bull. 170, p. 21-28.

- Ellsworth, W. L., 1990, Earthquake History, 1769-1989 in: The San Andreas Fault System, California: U.S. Geological Survey Professional Paper 1515, 283 p.
- International Code Council (ICC), 2006, International Building Code, 2006 Edition.
- Ishihara, K. (1985), Stability of natural deposits during earthquakes, Proc. 11th Int. Conf. On Soil Mech. And Found. Engrg., Vol. 1, A. A. Balkema, Rotterdam, The Netherlands, 321-376.
- Jennings, C. W., 1994, Fault activity map of California and Adjacent Areas: California Division of Mines and Geology, DMG Geologic Map No. 6.
- Jones, A. L., 2003, An Analytical Model and Application for Ground Surface Effects from Liquefaction, PhD. Dissertation, University of Washington, 362 p.
- Jones, L. and Hauksson, E., 1994, Review of potential earthquake sources in Southern California: Applied Technology Council, Proceedings of ATC 35-1.
- Morton, P. K., 1977, Geology and mineral resources of Imperial County, California: California Division of Mines and Geology, County Report No. 7, 104 p.
- Mualchin, L. and Jones, A. L., 1992, Peak acceleration from maximum credible earthquakes in California (Rock and Stiff Soil Sites): California Division of Mines and Geology, DMG Open File Report 92-01.
- Naeim, F. and Anderson, J. C., 1993, Classification and evaluation of earthquake records for design: Earthquake Engineering Research Institute, NEHRP Report.
- National Research Council, Committee of Earthquake Engineering, 1985, Liquefaction of Soils during Earthquakes: National Academy Press, Washington, D.C.
- Post-Tensioning Institute (PTI), 2004, Design of Post-Tensioned Slabs-on-Ground. 106 p.
- Post-Tensioning Institute (PTI), 2007, Standard Requirements for Design of Shallow Post-Tensioned Concrete Foundations on Expansive Soils. 16 p.
- Robertson, P. K. and Wride, C. E., 1996, Cyclic Liquefaction and its Evaluation based on the SPT and CPT, Proceeding of the NCEER Workshop on Evaluation of Liquefaction Resistance of Soils, NCEER Technical Report 97-0022, p. 41-88.
- Seed, Harry B., Idriss, I. M., and Arango I., 1983, Evaluation of liquefaction potential using field performance data: ASCE Geotechnical Journal, Vol. 109, No. 3.
- Seed, Harry B., et al, 1985, Influence of SPT Procedures in Soil Liquefaction Resistance Evaluations: ASCE Geotechnical Journal, Vol. 113, No. 8.

- Seed, R. B., Cetin, K. O., Moss, R. E. S., Kammerer, A. M., Wu, J., Pestana, J. M., Riemer, M. F., Sancio, R. B., Bray, J. D., Kayen, R. E., and Faris, A., 2003, Recent advances in soil liquefaction engineering: a unified and consistent framework: University of California, Earthquake Engineering Research Center Report 2003-06, 71 p.
- Sharp, R. V., 1982, Tectonic setting of the Imperial Valley region: U.S. Geological Survey Professional Paper 1254, p. 5-14.
- Sylvester, A. G., 1979, Earthquake damage in Imperial Valley, California May 18, 1940, as reported by T. A. Clark: Bulletin of the Seismological Society of America, v. 69, no. 2, p. 547-568.
- Tokimatsu, K. and Seed H. B., 1987, Evaluation of settlements in sands due to earthquake shaking: ASCE Geotechnical Journal, v. 113, no. 8.
- U.S. Geological Survey (USGS), 1982, The Imperial Valley California Earthquake of October 15, 1979: Professional Paper 1254, 451 p.
- U.S. Geological Survey (USGS), 1990, The San Andreas Fault System, California, Professional Paper 1515.
- U.S. Geological Survey (USGS), 1996, National Seismic Hazard Maps: available at <http://gldage.cr.usgs.gov>
- U.S. Geological Survey (USGS), 2007, Earthquake Ground Motion Parameters, Version 5.0.7: available at <http://earthquake.usgs.gov/research/hazmaps/design/>
- Wire Reinforcement Institute (WRI), 2003, Design of Slab-on-Ground Foundations, Tech Facts TF 700-R-03, 23 p.
- Working Group on California Earthquake Probabilities (WGCEP), 1992, Future seismic hazards in southern California, Phase I Report: California Division of Mines and Geology.
- Working Group on California Earthquake Probabilities (WGCEP), 1995, Seismic hazards in southern California, Probable Earthquakes, 1994-2014, Phase II Report: Southern California Earthquake Center.
- Youd, T. L., 2005, Liquefaction-induced flow, lateral spread, and ground oscillation, GSA Abstracts with Programs, Vol. 37, No. 7, p. 252.
- Youd, T. L. and Garris, C. T., 1995, Liquefaction induced ground surface disruption: ASCE Geotechnical Journal, Vol. 121, No. 11.

Youd, T. L., Hansen, C. M., and Bartlett, S. F., 1995, Revised Multilinear Regression Equations of Prediction of Lateral Spread Displacement: Journal of Geotechnical and Geoenvironmental Engineering, Vol. 128, No. 12, p. 1007-1017.

Youd, T. L. et. al., 2001, Liquefaction Resistance of Soils: Summary Report from the 1996 NCEER and 1998 NCEER/NSF Workshops on Evaluation of Liquefaction Resistance of Soils: Journal of Geotechnical and Geoenvironmental Engineering, Vol. 127, No. 10, p. 817-833.

Zimmerman, R. P., 1981, Soil survey of Imperial County, California, Imperial Valley Area: U.S. Dept. of Agriculture Soil Conservation Service, 112 p.

Biological Assessment (dated August 2018)

EEC ORIGINAL PKG

**J.R. SIMPLOT-FERTILIZER
TERMINAL RELOCATION
BIOLOGICAL ASSESSMENT**

AUGUST, 2018

Prepared for:

**J. R. Simplot
Gary L. Smith
302 Danenberg Drive
El Centro, CA 92243**

Prepared by:

**Barrett's Biological Surveys
Certified as performed in accordance with
established biological practices by:**



**Marie S. Barrett, Biologist
2035 Forrester Road
El Centro, Ca 92243
760.352.4159**

CONTENTS

I.	PROJECT DESCRIPTION	3
II.	BIOLOGICAL REQUIREMENTS	5
III.	BIOLOGICAL ASSESSMENT SURVEY	5
	Table 1: Field Survey	6
IV.	BIOLOGICAL OBSERVATIONS	6
	Table 2: Vegetation	6
	Table 3: Animals/Invertebrates	6
	Table 4: BUOW Burrow Locations	7
V.	AVOIDANCE, MINIMIZATION AND MITIGATIONS	7

APPENDIX A: SENSITIVE BOTANICAL AND ZOOLOGICAL SPECIES (CNDDDB/CNPS)

APPENDIX B : PHOTOGRAPHS

APPENDIX C: VICINITY MAP/BIOLOGICAL RESOURCE MAP

APPENDIX D: QUALIFICATIONS

I. PROJECT DESCRIPTION

J.R.Simplot Company (“applicant”) proposes to relocate its’ fertilizer warehouse/terminal where fertilizer will be received, warehoused and shipped. The project site will receive both solid and liquid fertilizers via Southern Pacific Rail Road, and distribute the fertilizer via trucks. In terms of fertilizer, the facility will utilize segregation for storage purposes. Segregation is a mixture of different kinds of fertilizers in order to obtain a predicted Nitrogen (N) Phosphate (P) Potassium (K) chemical composition of solid fertilizer. Therefore, the facility will have the capacity to store 14,075 tons of eight different dry/solid product segregations, and 15,000 tons of four different product segregations of liquid fertilizer. Both the liquid and solid fertilizer will be shipped via truck to recipients.

The entire APN 040-340-043 is currently situated on approximately 39.96 +/- acres of land located within the County of Imperial, about 2 miles north of the City of Imperial². Currently, the project site is zoned ML-I-2 (Medium-Industrial) and is within the Mesquite Lake Specific Plan³, as seen in Figure 1.

The primary entrance for the facility is on Harris Road, west of the Southern Pacific Railroad tracks. This primary entrance will receive automobiles for employees and business related traffic. Traffic related activity will include inspections, employees, visitors as well as distribution trucks. Per the County Fire Marshall, a secondary access point will be required for emergency access only. This entrance shall not affect the amount of project traffic counts and will be located just west of the main entrance. Trucks will travel on S.R. 86 for distribution to the end users’ locations according to the proposed site plan. There will be paved roadway on site for queuing of trucks.

Operations:

Solid Fertilizer:

Located at the northern portion of the facility, a proposed rail yard will be used for unloading fertilizer material. At the north/western side of the facility a 250 TPH drag chain bucket elevator and conveyor will transfer dry fertilizer products from the train cars into Dry Bulk Warehouse 1. The conveyor will receive the product at a shallow rail receiving pit, placed below the working track, and convey the material to a diverter located within the Dry Bulk Warehouse 1. Once fertilizer reaches this diverter, there are two options; (a) the fertilizer will be diverted via a conveyor belt to be stored within Dry Bulk Warehouse 1 and (b) the fertilizer will be transported via an additional covered conveyor belt that will run perpendicular from Dry Bulk Warehouse 1 to its destination in Dry Bulk Waterhouse 2 where the fertilizer will be stored.

Walls separating the different types of fertilizer will be 10’ high, made out of large cement blocks, and will be moveable to allow for seasonal and market demand

fluctuation. The two warehouse buildings are identical in size: 100' x 340' with a peak height of 50'. The buildings will be set up to allow drive through loading. A passageway will be constructed between the buildings to allow a front end loader to travel between the buildings. Prior to operation of drag chain bucket elevator, applicant will have filed and received permitted approval.

Liquid Fertilizer:

Located on the north/eastern side of the facility will be two stations for the unloading of liquid fertilizers from train cars⁵. All unloading stations will have spill containment area constructed of curbs and concrete slabs. Five 60 Horse Power (HP) pumps will be located at these unloading stations in order to pump the liquid fertilizer to the Contained Liquid Storage Area, where the liquid fertilizer will be stored in four different storage tanks ranging in sizes⁶. Once liquid fertilizer is ready to be transported to recipients, a 25 HP pump will pump liquid fertilizer to the loading location. This location will have four different outlets connected to the four different storage tanks.

The fertilizer will be weighed by a 10'x80' fully electronic scale located north of the primary access. The product will be weighted via electronic scale upon receipt and before shipping to clients.

Proposed Project Boundary:

This project will be responsible for granting one half of eighty four (84'-00") of Right-of-Way (ROW), along both the western and southern project boundaries. A thirty five (35'-00") ROW already exists along the project's southern boundary (Harris Road); this project will dedicate the additional seven (7'-00") to meet that required forty two (42'-00") of ROW. Additionally, the project will have to dedicate the entire forty two (42'-00") of ROW on the western boundary.

Utilities:

The applicant will have an agreement with the County of Imperial to supply potable water via reservoir tanks. Due to project site location, sewage will be disposed via septic tank and leach bed field. An office and maintenance shop will be provided for employees, along with corresponding amount of parking. Outside lighting will be provided for night operations.

Applicant wishes to adhere to all Imperial County land use and zoning regulations required for this location.

Jurisdictions:

- 1) County of Imperial

Applications:

- 1) Conditional Use Permit (CUP) - County of Imperial
- 2) Site Plan

Figure 1

Simplot- Fertilizer Terminal Relocation



II. BIOLOGICAL REQUIREMENTS

Barrett's Biological Surveys has conducted biological assessment field survey of the area that conforms with California Department of Fish and Wildlife guidelines. The results of the survey are provided in this report.

III. BIOLOGICAL ASSESSMENT SURVEY

On 24 August, 2018, a biological assessment was conducted by Glenna Barrett and Dani Figueroa, biologists, on the Project site. A 500 foot buffer area was also surveyed. The project is located on the project site

Table 1: Field Survey

Date	Surveyors	Hours/Surveyor	Total hours/day	Conditions
8/24/18	Glenna Barrett Dani Figueroa	600-800 2.0 hrs	4.0	83-87°F/0% cloud cover/0-3 mph
		Total hours in field	4.0	

IV. BIOLOGICAL OBSERVATIONS

Surveys were conducted to determine the presence/absence nesting birds and of Western Burrowing Owl, *Athene cunicularia hypugaea*, using procedures found in *Staff Report on Burrowing Owl Mitigation, California Department of Fish and Game (Wildlife), 2012.*

Table 2 Ruderal vegetation found around the project site:

Common name	Scientific name	Cal-IPC Rating*
Alkali mallow	<i>Malvella leprosa</i>	
Quail bush	<i>Atriplex lentiformis</i>	
Bermuda	<i>Cynodon dactylon</i>	
Sprangle top	<i>Leptochloa Chinensis</i>	
Palm trees	<i>Phoenix Genus</i>	
Alkali heliotrope	<i>Heliotropium curassavicum</i>	
Saltcedar	<i>Tamarix sp.</i>	Ca Noxious Weed Cal-IPC rating: High

No vegetation was found that would be considered endangered, threatened or species of concern. No vegetation onsite.

Table 3 Animals/Invertebrates were observed in vicinity:

Common name	Scientific name
Burrowing owl	<i>Athene cunicularia</i>
Killdeer	
Eurasian collared dove	
Grackle	<i>Quiscalus mexicanus</i>
Mourning dove	<i>Zenaida macroura</i>
Redwinged blackbird	<i>Agelaius phoeniceus</i>
Gambels quail	<i>Callipepla gambelii</i>
Western meadowlark	<i>Sturnella neglecta</i>
Scorpion tracks	<i>unknown</i>
Alfalfa butterfly	<i>Colias eurytheme</i>
Common bee	<i>Aphis spp.</i>
Velvet ant	<i>Dasymutilla occidentalis</i>
Ants	<i>various</i>
Crickets	<i>Gryllus</i>

Raccoon tracks	<i>Procyon lotor</i>
Gopher mound	<i>Thomomys bottae</i>
Canine tracks	<i>various</i>
Cottontail	<i>Sylvilagus audubonii</i>

No fauna was found that would be considered endangered or threatened

Two burrowing owls, a CDFW species of concern and two occupied burrow were found offsite on Imperial Irrigation District Right Of Way (IIDROW). The table below lists the locations BUOW or burrows were observed and appropriate avoidance, minimization and mitigation techniques.

Table 4: BUOW Burrow Locations

Location WGS 84 EPE 11-13 ft	Biological Resource	Minimization/Mitigation
1. 32°53'5.4"/115°33'42.6" West side of IID drain	Occupied burrow 1 adult BUOW	Offsite: Shelter in place with haybales if construction within 250 ft (February-August) or 160 feet (Sept-January)
2. 32°53'2.4"/115°33'44.0" East side of IID Drain	Occupied burrow 1 adult BUOW	Offsite: Shelter in place with haybales if construction within 250 ft (February-August) or 160 feet (Sept-January)

Burrowing owls, a CDFW species of concern, occupied and active burrows were found; they could be within 160-250 foot buffer zone of construction activities.

This survey was conducted during the prime nesting season for BUOW; BUOW were observed. Habitat on site was determined suitable for BUOW foraging or burrowing.

V. AVOIDANCE, MINIMIZATION AND MITIGATION ACTIVITIES DURING CONSTRUCTION

Activities, under the supervision of a biologist, include the following:

- BUOW shelter in place (using hay bales) and remove shelters when project is complete under supervision of qualified biologist. If passive relocations are required, qualified biologist shall consult with CDFW, Palm Desert office.
- Worker BUOW training sessions
- Monitoring when construction is within 250 feet (February-August); 160 feet (September-January) if determined necessary by qualified biologist

- **If construction started during Migratory Bird Nesting season (February-August) a nesting bird survey should be completed one week prior to start of construction**
- **Within 14 days and 24 hours of start of construction, BUOW survey**

**APPENDIX A
SENSITIVE SPECIES**

APPENDIX A
SENSITIVE BOTANICAL AND ZOOLOGICAL SPECIES (CNDDDB/CNPS/USFWS LISTS)
El Centro Quadrangle (Nine Quad Search) August, 2018

BOTANICAL SPECIES	STATUS¹	DESCRIPTION OF SPECIES	HABITAT	OBSERVATION/ SITE POTENTIAL
Chaparral sand-verbena <i>Abronia villosa var aurita</i>	State: S2.2 (not very threatened); CNPS list:1B.2 (rare, threatened in Ca; fairly endangered in Ca.)	Likes full sun, and sandy soil. Sand-verbena has gray foliage with pinkish purple flowers, and the flowers are fragrant. It does not tolerate weeds and needs bare ground. 80-1600m (263-5249ft)	Chaparral, Coastal Shrub, and desert dunes/sandy areas.	No habitat; none observed
Sand Food <i>Pholisma sonora</i>	State: 1B.2	Its fleshy stem extending up to two meters-six feet below the surface and emerging above as a small rounded or ovate form	It is a parasitic plant which attaches to the roots of various desert shrubs such as wild buckwheats, ragweeds, pluchees, and <i>Tiquillia plicata</i> and <i>T. palmeri</i> to obtain nutrients.	No habitat; none observed
Mud Nama <i>Nama stenocarpum</i>	State: S2.2 (not very threatened)		This tiny annual herb grows on the muddy embankments of ponds and lakes. It is also reported to utilize river embankments.	No habitat; none observed

BOTANICAL SPECIES	STATUS'	DESCRIPTION OF SPECIES	HABITAT	OBSERVATION/ SITE POTENTIAL
Annual Rock-Nettle <i>Eucnide rupestris</i>	State: S2.2 (not very threatened)	Annual Perennial Growth Habit: Forb/herb Native Status	The preferred habitat in Sonoran Desert Scrub is in rocky rubble or talus. Only known location in Imperial County is Painted Gorge.	No habitat; none observed
Gravel Milk-Vetch <i>Astragalus sabulorum</i>	State: S2.2 (not very threatened)	Annual Perennial Growth Habit: Forb/herb Native Status: L48 N	Found in sandy or gravelly areas; 100-650feet.; flowers between Feb-Jul	No habitat; none observed
California setintail <i>Imperata brevifolia</i>	CNDDDB Ranks G2, S2.1; CNS: 2.1	This plant can be weedy or invasive. Grass or grass-like plant, including grasses (Poaceae), sedges (Cyperaceae), rushes (Juncaceae), arrow-grasses (Juncaginaceae), and quillworts (Isoetes).	It is native to the southwestern United States from California to Texas and northern Mexico, where it grows in arid regions where water is available.	No habitat; none observed
Hairy Stickleaf <i>Mentzelia hirsutissima</i>	CNDDDB Ranks G3, S2S3; CNPS: 2.3	Annual to shrub; hairs needle-like, stinging, or rough	Creosote Bush Scrub	No habitat; none observed

BOTANICAL SPECIES	STATUS ¹	DESCRIPTION OF SPECIES	HABITAT	OBSERVATION/ SITE POTENTIAL
Brown turbans <i>Malperia tenuis</i>	CNDDDB Ranks G4, S1.3; CNPS: 2.3	is recognized by its annual duration, linear leaves densely arranged along stems or concentrated near bases of stems, loosely arranged heads, and pappi of two kinds of scales.	Sonoran Desert Scrub is the general habitat for Brown Turbans. Near Ocotillo it grows on arid slopes with shallow soils, rocky surface rubble with few large boulders, and little competition from shrubs.	No habitat; none observed
Thurber's Pileostyles <i>Pileostyles thurberi</i>	CNDDDB Ranks G5, S3.3; CNPS: 4.3	a dicot, is a perennial herb (parasitic) that is native to California and is also found outside of California, but is confined to western North America.	Creosote Bush Scrub	No habitat; none observed
Pink Fairy Duster <i>Calliandra eriophylla</i>	CNDDDB Ranks G5, S2S3; CNPS: 2.3	Fairy Duster is a low, densely branched shrub 8 to 48 inches high. The leaves are formed by 2-to-4 pairs of 1/4-inch, oblong leaflets. It is a member of the Pea Family (Fabaceae) which includes acacias and mimosas.	Open hillsides, sandy desert washes and slopes below 5,000 feet.	No habitat; none observed

BOTANICAL SPECIES	STATUS¹	DESCRIPTION OF SPECIES	HABITAT	OBSERVATION/ SITE POTENTIAL
Abrams's Spurge <i>Chamaesyce abramisiana</i>	CNPS list: 2	Annual herbaceous blooms Sept/Nov. Common spurge in area has large purple spot and is prostrate; Abram's is not as colorful.	Sonoran Desert Shrub	No habitat; no Abrams's spurge found.
ZOOLOGICAL SPECIES	STATUS¹	DESCRIPTION OF SPECIES	HABITAT	OBSERVATION/ SITE POTENTIAL
Birds				
Yuma clapper rail (Ridgway Clapper) <i>Rallus longirostris yumanensis</i>	Fed: Endangered Ca: Threatened	A chickenlike marsh bird with a long, slightly drooping bill and an often upturned tail. Light brownish with dark streaks above. Rust-colored breast; bold, vertical gray and white bars on the flanks; white undertail coverts	Lives in freshwater and brackish marshes. Prefers dense cattails, bulrushes, and other aquatic vegetation. Nests in riverine wetlands near upland, in shallow sites dominated by mature vegetation, often in the base of a shrub. Prefers denser cover in winter than in summer. Very shy.	None observed or heard; Cattails not found in dense stands; no suitable habitat on site or in adjacent drains.

ZOOLOGICAL SPECIES	STATUS¹	DESCRIPTION OF SPECIES	HABITAT	OBSERVATION/ SITE POTENTIAL
Burrowing Owl <i>Athene cunicularia</i>	CDFG: SC Species of Concern	Small raptors that nest in burrows that have been borrowed from other species in open grassland areas. Have adapted well in Imperial County using canals/drains/ditches to establish burrows and foraging for insects in agricultural fields	Open, dry annual or perennial grasslands; deserts & scrublands	BUOW Owls/burrows found off site on IID ROW. Survey results included in this report

ZOOLOGICAL SPECIES	STATUS'	DESCRIPTION OF SPECIES	HABITAT	OBSERVATION/ SITE POTENTIAL
<p>Vermillion flycatcher</p> <p><i>Pyrocephalus rubinus</i></p>	<p>CDFG: SC Species of Concern</p>	<p>Length: 5 inches. The adult male has a Bright red cap, throat and underparts; with a Black eyeline, nape, back, wings, and tail. The Immature male similar to female but has variable amount of red on underparts. The female and immature has Brown upperparts with White underparts with faint streaks on breast with an undertail coverts tinged pink The adult male Vermillion Flycatcher is very distinctive. The female and immatures are more nondescript but the streaking on the breast and pink tinge to the undertail coverts distinguish them from other flycatchers.</p>	<p>Frequents stream and ponds in arid areas; agricultural areas</p>	<p>None observed; not expected.</p>

ZOOLOGICAL SPECIES	STATUS ¹	DESCRIPTION OF SPECIES	HABITAT	OBSERVATION/ SITE POTENTIAL
<p>Yellow Warbler <i>Dendroica petechia brewsteri</i></p>	<p>CNDDDB Rank: G5T3, S2; CDFG: SC</p>	<p>A Family of seed-eating, small to moderately large passerine birds that have strong, stubby beaks , which in some species can be quite large. They have a bouncing flight, alternating flapping with gliding on closed wings. Most sing well.</p>	<p>Yellow warblers in southern California breed in lowland and foothill riparian woodlands dominated by cottonwoods, alders, or willows and other small trees and shrubs typical of low, open-canopy riparian woodland (Garrett and Dunn 1981). During migration, they occur in lowland and foothill woodland habitats such as desert oases, riparian woodlands, oak woodlands, mixed deciduous-coniferous woodlands, suburban and urban gardens and parks, groves of exotic trees, farmyard windbreaks, and orchards (Small 1994).</p>	<p>No habitat on site; none observed</p>

ZOOLOGICAL SPECIES	STATUS ¹	DESCRIPTION OF SPECIES	HABITAT	OBSERVATION/SITE POTENTIAL
Crissal Thrasher <i>Toxostoma crissale</i>	CDFG Species of Concern	A large thrasher found in the Southwestern United States to central Mexico. The bird grows to 32 cm (12.5 inches), and has a deeply curved bill. It can be found near water in dense underbrush, and in the low desert near canyon chaparral; seldom flies in the open.	Dense vegetation along streams/washes in mesquite/willows/arrowweed	L None observed; scarce habitat
Gila Woodpecker <i>Melanerpes uropygialis</i>	Fed: - CDFG Endangered	Bill black to grayish black with dark red to reddish hazel eyes. About 9.3 inches long with brownish green or bluish legs and feet. Black and white barring on back male has red cap on head. Buff-brown face, neck and breast with barred rump and central tail feathers.	Uncommon to resident in southern California along the Colorado River, and locally near Brawley. Occurs mostly in desert riparian and desert wash habitats. Cottonwoods and other desert riparian trees, shade trees, and date palms supply cover.	L No suitable habitat; few palm trees or other trees on site; may fly through site.

ZOOLOGICAL SPECIES	STATUS ¹	DESCRIPTION OF SPECIES	HABITAT	OBSERVATION/ SITE POTENTIAL
Ferruginous hawk <i>Buteo regalis</i>	/SC/		Found in arid to semiarid regions, as well as grasslands and agricultural areas in southwestern Canada, western United States, and northern Mexico.	L None observed but could fly through site
California Black Rail <i>Laterallus jamaicensis coturniculus</i>	CDFG: Threatened	The smallest of all rails, the black rail is slate-colored, with a black bill, red eyes and a white-speckled back. The legs are moderately long and the toes are unwebbed. The sexes are similar.	Most commonly occurs in tidal emergent wetlands dominated by pickleweed or in brackish marshes with bulrushes in association with pickleweed. In freshwater, usually found in bulrushes, cattails, and saltgrass and in immediate vicinity of tidal sloughs. Typically occurs in the high wetland zones near upper limit of tidal flooding, not in low wetland areas with considerable annual or daily fluctuations in water levels. Nests are concealed in dense vegetation, often pickleweed, near upper limits of tidal flooding	L None observed; no habitat on site

ZOOLOGICAL SPECIES	STATUS ¹	DESCRIPTION OF SPECIES	HABITAT	OBSERVATION/ SITE POTENTIAL
<p>Leopard frog</p> <p><i>Lithobates yavapaiensis</i></p>	<p>Species of concern</p>	<p>Tan, gray-brown or light gray-green to green above; yellow below. Vague upper lip stripe, tuberculate skin. Dark network on rear of thighs; yellow groin color often extends onto rear of belly and underside of legs. Male will exhibit a swollen and darkened thumb base.</p>	<p>Find in desert grassland and in woodlands. Uses permanent water sources, stays near water. Breed Feb-April. Bullfrogs are predators</p>	<p>L</p> <p>No water sources on site; not expected on site.</p>
<p>Sonoran desert toad</p> <p><i>Incilius alvarius</i></p>	<p>CDFG: SC</p>	<p>Large: 7.5 inches or more in length. Smooth, typically olive-green/brown skin, cranial crests, and prominent, elongated glands on both sides of the back of the head (parotoid glands) and on the hind legs. Young toads have small dark, orange-tipped spots on the back. Larger tadpoles are gray or brown with a rounded tail tip, and grow to about 2.25 inches.</p>	<p>Sonoran Desert scrub, semi-desert grasslands. Can be tied to permanent water, such as major rivers or the edges of agriculture. May be found many miles from water, particularly during the summer monsoons. Most Sonoran Desert toads are found at night during the monsoon season, but they may emerge a month or more before the summer rains begin, particularly in areas of permanent water. Can be found in rodent burrows or underground retreats.</p>	<p>L</p> <p>None observed. No habitat present on site.</p>

ZOOLOGICAL SPECIES	STATUS ¹	DESCRIPTION OF SPECIES	HABITAT	OBSERVATION/ SITE POTENTIAL
Northern leopard frog <i>Lithobates pipiens</i>	CDFG: SC	2-3½ inches long and has randomly distributed black spots on its back, sides, and legs. Each spot is surrounded by a light halo. The background colors of the frog can range from gold to green. Gold or brown dorsolateral ridges often stand out in contrast. White belly with no other markings	NLF needs permanent water for overwintering, floodplains and marshes for breeding, and wet meadows and fields for foraging	L No habitat on site or nearby
Flat-tailed horned lizard <i>Phrynosoma mcallii</i>	CNDDB Rank: G3; S2 CDFG: SC	A small (up to 87 mm or 3.4" from snout to vent), exceptionally flat and wide lizard with a long (for a horned lizard) broad, flat tail and a dark stripe running down the middle of the back.	occupy a small range in the Sonoran Desert of southwestern California, southwestern Arizona, and extreme northern Mexico.	L No sandy habitat
Colorado Desert fringe-toed lizard <i>Uma notata</i>	CNDDB Rank: G3, S2; CDFG: SC	2 3/4 to 4 4/5 inches long from snout to vent (7 - 12.2 cm). (Stebbins 2003) The tail is about the same length as the body.	Sparsely-vegetated arid areas with fine wind-blown sand, including dunes, flats with sandy hummocks formed around the bases of vegetation, washes, and the banks of rivers. Needs fine, loose sand for burrowing.	L No sandy habitat

ZOOLOGICAL SPECIES	STATUS ^a	DESCRIPTION OF SPECIES	HABITAT	OBSERVATION/ SITE POTENTIAL
<p>American Badger</p> <p><i>Taxidea taxus</i></p>	<p>CDFG: Species of Concern</p>	<p>Burrowing animals that feed on ground squirrels, rabbits, gophers and other small animals. Prefer grasslands, agricultural areas.</p>	<p>Found in drier open areas with friable soils</p>	<p>L None seen; no burrows observed with badger characteristics observed. Not expected because of low prey opportunity</p>
<p>Pocketed free-tailed bat</p> <p><i>Nyctinomops femorosaccus</i></p>	<p>CNDDB Rank: G4, S2S3; CDFG: SC</p>	<p>A small fold, or "pocket" in the wing membrane of the free-tailed bat, near its knee, gives this bat its common name. Pocketed free-tailed bats have large ears and long wings, and fly rapidly, generally pursuing insects on the wing. They eat many kinds of insects, but seem to prefer small moths.</p>	<p>It occurs in the arid lowlands of the desert Southwest, and primarily roosts in crevices in rugged cliffs, slopes, and tall rocky outcrops.</p>	<p>L No nesting habitat</p>

ZOOLOGICAL SPECIES	STATUS¹	DESCRIPTION OF SPECIES	HABITAT	OBSERVATION/ SITE POTENTIAL
Western Mastiff Bat <i>Eumops perotis californicus</i>	CNDDDB Rank: G5T4, S3; CDFG: SC	Eumops perotis can be distinguished from all other North American molossid (free-tail) species based on size. With a forearm of 73-83 mm, it is North America's largest species.	In California, the E. perotis is most frequently encountered in broad open areas. Generally, this bat is found in a variety of habitats, from dry desert washes, flood plains, chaparral, oak woodland, open ponderosa pine forest, grassland, montane meadows, and agricultural areas.	L Low prey opportunity
Western Yellow bat <i>Lasiurus xanthinus</i>	CDFG SC:	Consumes small to medium-sized, night flying insects. Yellow color/short ears.	Roosts in leafy vegetation the deserts of the southwestern United States. Roosts among the dead fronds of palm trees and cottonwoods	L Not expected; few palms and no cottonwood trees found on site.
Big free tailed bat <i>Nyctinomops macrotis</i>	CDFG: SC	Body length of 5 1/8 to 5 3/4", with a 17" wingspan, which makes it bigger than other free tailed bats. Fur is reddish brown to dark brown, with hairs white at base. Tail extends past membrane at least an inch. Big ears are joined at base and extend out over face like a hat. Eats mostly moths, some crickets, grasshoppers, ants, various other insects.	Lives in rocky areas of desert scrub or coniferous forests. During day roosts in crevices on cliff faces.	L None seen. Not expected; no roosting habitat.

ZOOLOGICAL SPECIES	STATUS¹	DESCRIPTION OF SPECIES	HABITAT	OBSERVATION/ SITE POTENTIAL
Colorado Valley woodrat <i>Neotoma albigula venusta</i>	CNDDDB Rank: G5T3T4, S1S2	a small rodent measuring an average of 12.9 inches (32.8 cm) and weighing an average of 188 g for females and 224 g for males	Typically found at an altitude of 0 to 1,966 meters (0 to 6,450 feet). Mesquite-creosotebush	L No habitat on site
Palm Springs pocket mouse <i>Perognathus longimembris bangsi</i>	CDFG: SC	Small heteromyid rodent with length of about 110 to 151 mm and weight from 8 to 11 g. There are usually two small patches of lighter hairs at the base of the ear. There is no a tail-crest, and an unlobed antitragus in the outer ear.	Creosote scrub, desert scrub, and grasslands, with loosely packed or sandy soils with sparse to moderately dense vegetative cover. <i>P. l. bangsi</i> occurs only in the Coachella Valley, where substantial agricultural and urban/suburban conversion of habitat, especially in the valley floor, has occurred over the last century. The species occurs only in native habitats.	L No habitat

Special Status Species that Occur in Imperial County (USFWS)				
Common Name Scientific Name	Status ¹ Federal/CDFG /CNPS	DESCRIPTION OF SPECIES	Habitat	Suitability Of Habitat In Survey Area
Plants				
Peirson's milk-vetch <i>Astragalus magdalenae</i> var. <i>peirsonii</i>	T/E/1B	Silvery, short-lived perennial plant that is somewhat broom like in appearance. A member of the pea and bean family, it can grow to 2.5 feet tall and is notable among milkvetches for its greatly reduced leaves. Peirson's milkvetch produces attractive, small purple flowers, generally in March or April, with 10 to 17 flowers per stalk. It yields inflated fruit similar to yellow-green pea pods with triangular beaks.	Desert dune habitats. In California, known from sand dunes in the Algodones Dunes system of Imperial County. Was known historically from Borrego Valley in San Diego County and at a site southwest of the Salton Sea in Imperial County	L None observed. No dune habitat

Common Name Scientific Name	Status ¹ Federal/CDFG /CNPS	DESCRIPTION OF SPECIES	Habitat	Suitability Of Habitat In Survey Area
Birds				
California brown pelican <i>Pelecanus occidentalis</i>	E/E/- No longer endangered	Large size and brown color. Adults weigh approximately 9 pounds, and have a wingspan of over 6 feet. They have long, dark bills with big pouches for catching and holding fish. Pelicans breed in nesting colonies on islands without mammal predators. Roosting and loafing sites provide important resting habitat for breeding and non-breeding birds.	Open water, estuaries, beaches; roosts on various structures, such as pilings, boat docks, breakwaters, and mudflats	L None observed. No open water
Southwestern willow flycatcher <i>Empidonax traillii extimus</i>	E/-/-	Small; usually a little less than 6 inches in length, including tail. Conspicuous light-colored wingbars. Lacks the conspicuous pale eye-ring of many similar <i>Empidonax</i> species. Overall, body brownish- olive to gray-green above. Throat whitish, breast pale olive, and belly yellowish. Bill relatively large; lower mandible completely pale. The breeding range of <i>extimus</i> includes Arizona and adjacent states.	At low elevations, breeds principally in dense willow, cottonwood, and tamarisk thickets and in woodlands, along streams and rivers. Migrants may occur more widely. Prefers riparian willow/cottonwood but will use salt cedar thickets	L None Observed. No suitable tamarix thickets or available water for habitat

Common Name Scientific Name	Status ¹ Federal/CDFG /CNPS	DESCRIPTION OF SPECIES	Habitat	Suitability Of Habitat In Survey Area
Yuma clapper rail <i>Rallus longirostris yumanensis</i>	E/T/-	A chickenlike marsh bird with a long, slightly drooping bill and an often upturned tail. Light brownish with dark streaks above. Rust-colored breast; bold, vertical gray and white bars on the flanks; white undertail coverts. Very shy.	Lives in freshwater and brackish marshes. Prefers dense cattails, bulrushes, and other aquatic vegetation. Nests in riverine wetlands near upland, in shallow sites dominated by mature vegetation, often in the base of a shrub. Prefers denser cover in winter than in summer..	L None observed or heard; no suitable habitat; surveys did not find cattail habitat
Yellow-billed cuckoo <i>Coccyzus americanus</i>	C/E/-	Medium-sized cuckoo with gray-brown upperparts and white underparts. Eye-rings are pale yellow. Bill is mostly yellow. Wings are gray-brown with rufous primaries. Tail is long and has white-spotted black edges. Sexes are similar.	Found in forest and open woodlands, especially in areas with dense undergrowth, such as parks, riparian woodlands, and thickets	L None observed; no habitat on site

Common Name Scientific Name	Status ¹ Federal/GDFG /CNPS	DESCRIPTION OF SPECIES	Habitat	Suitability Of Habitat In Survey Area
Bald eagle <i>Haliaeetus leucocephalus</i>	T, PD/E/-	The distinctive white head and tall feathers. Beak and eyes yellow. Bald Eagles are about 29 to 42 inches long, can weigh 7 to 15 pounds, and have a wing span of 6 to 8 feet.	Found on shores, lake margins, and near large rivers. Nests in large trees. Winters at lakes, reservoirs, river systems, and some rangelands and coastal wetlands (breeding range is mainly in mountainous habitats near reservoirs, lakes and rivers, mainly in the northern two-thirds of California)	L None observed; no habitat
Least tern <i>Sterna antillarum</i>	E/E/-	Small tern. During breeding, black cap ending at white forehead. Short white eyestripe. Bill yellow with black tip. Back light gray. Underside white. Black leading edge to wing. In nonbreeding plumage has black eyestripe extending to back of head, white top of head, and black bill. Size: 21-23 cm (8-9 in) Wingspan: 48-53 cm (19-21 in) Weight: 30-45 g (1.06-1.59 ounces)	Shallow areas of estuaries, lagoons, and at the joining points between rivers and estuaries	L None observed; no habitat

Common Name Scientific Name	Status ¹ Federal/CDFG /CNPS	DESCRIPTION OF SPECIES	Habitat	Suitability Of Habitat In Survey Area
Least Bell's Vireo <i>Vireo bellii pusillus</i>	E/E/-	Drab gray to green above and white to yellow below. It has a faint white eyering and two pale wingbars; has pale whitish cheeks and forehead and greenish wings and tail. longer tail and subtle wingbars. The song is a varied sequence of sharp, slurred phrases that typically end with an ascending or descending note.	Formerly a common and widespread summer resident below about 2,000 feet in western Sierra Nevada. Also was common in coastal southern California, from Santa Barbara County south, below about 4,000 feet east of the Sierra Nevada. Prefers thickets of willow, and other low shrubs afford nesting and roosting cover	L None observed; no habitat on site. Thickets are not present
Mountain plover <i>Charadrius montanus</i>	FPT/SC/-	Medium-sized plover with pale brown upperparts, white underparts, and brown sides. Head has brown cap, white face, and dark eyestripe. Upperwings are brown with black edges and white bars; underwings are white. Tail is brown-black with white edges. Sexes are similar.	Avoids high and dense cover. Uses open grass plains, plowed fields with little vegetation, and open sagebrush areas. Likes to follow livestock grazing or burned off fields.	M None observed; could be found in adjacent fields if planted to Bermuda or alfalfa

Common Name Scientific Name	Status ¹ Federal/CDFG /CNPS	DESCRIPTION OF SPECIES	Habitat	Suitability Of Habitat In Survey Area
Black rail <i>Laterallus jamaicensis coturniculus</i>	-I/-	The smallest of all rails, the black rail is slate-colored, with a black bill, red eyes and a white-speckled back. The legs are moderately long and the toes are unwebbed. The sexes are similar.	Most commonly occurs in tidal emergent wetlands dominated by pickleweed or in brackish marshes with bulrushes in association with pickleweed. In freshwater, usually found in bulrushes, cattails, and saltgrass and in immediate vicinity of tidal sloughs. Typically occurs in the high wetland zones near upper limit of tidal flooding, not in low wetland areas with considerable annual or daily fluctuations in water levels. Nests are concealed in dense vegetation, often pickleweed, near upper limits of tidal flooding	L None observed; no habitat
Raptors				
Peregrine Falcon <i>Falco peregrinus</i>	D/E/-	Large, powerful falcon; pointed winged falcon silhouette. Strong shallow wingbeats may dive at speeds up to 100 mph. Dark with dark hooded effect. Blue gray below with narrow bars Long-winged, long tailed hawk. Habitually flies low over open fields and marshes watching and listening for prey such as rodents and birds. (I observed Harrier with a white faced ibis as prey). Perches low or on ground. Low slow flight.	Most often found along coastlines or marshy habitats. Nest in cliffs and have been known to nest in tall buildings	L None observed; rare visitors to area outside of the Salton Sea. No waterfowl for prey or cliffs/tall buildings for nesting

Common Name Scientific Name	Status¹ Federal/GDFG /CNPS	DESCRIPTION OF SPECIES	Habitat	Suitability Of Habitat In Survey Area
Northern Harrier <i>Circus cyaneus</i>	-/SC/-	Blue gray above pale reddish below; small size. Tip of tail squared off. Nesting occurs in dense tree stands which are cool, moist, well shaded and usually near water. Hunt in openings at the edges of woodlands and also brushy pastures.	Marshes, open fields. Nests in reeds	L Not observed on site
Sharp-shinned Hawk <i>Accipiter striatus</i>	-/SC/-	Gray and white with black on shoulders and under bend of wing. Graceful flyer. Adults have bright red eyes. Medium size hawk; about 15 inches long and about 12 ounces. Males pale with rufous shoulders and thigh feathers. White tail washed with rufous. Wide head wings in shallow v when soaring.	Sharp-shinned hawks may appear in woodland habitats during winter and migration periods and are often common in southern California in the coastal lowlands and desert areas; winters in woodlands and other habitats except alpine, open prairie and bare desert	L Not observed
White tailed Kite <i>Elanus leucurus</i>	/E/		Found in open country; like to perch on treetop. May be seen hovering prior to attack of a rodent.	L None observed

Common Name Scientific Name	Status ¹ Federal/CDFG /CNPS	DESCRIPTION OF SPECIES	Habitat	Suitability Of Habitat In Survey Area
Ferruginous hawk <i>Buteo regalis</i>	/SC/		Found in arid to semiarid regions, as well as grasslands and agricultural areas in southwestern Canada, western United States, and northern Mexico.	L None observed
Mammals				
Bighorn sheep <i>Ovis canadensis</i>	E/E/-	Sheep have short hair which is light gray to grayish brown, except around their stomachs and rump, where it is creamy white. Their tails are about four inches long. Full-grown rams weigh between 180 and 240 pounds.	Desert Bighorn sheep occupy a variety of plant communities, ranging from mixed-grass hillsides, shrubs. Avoids dense vegetation	L None observed; no habitat

Common Name Scientific Name	Status ¹ Federal/CDFG /CNPS	DESCRIPTION OF SPECIES	Habitat	Suitability Of Habitat In Survey Area
Reptiles and Amphibians				
<p>Desert tortoise</p> <p><i>Gopherus agassizii</i></p>	T/T/-	<p>A herbivore that may attain a length of 9 to 15 inches in upper shell (carapace) length. The tortoise is able to live where ground temperature may exceed 140 degrees F because of its ability to dig underground burrows and escape the heat. At least 95% of its life is spent in burrows. Their shells are high-domed, and greenish-tan to dark brown in color. Desert tortoises can grow from 4-8" in height and weigh 8-15 lb (4-7 kg) when fully grown. The front limbs have heavy, claw-like scales and are flattened for digging. Back legs are more stumpy and elephantine</p>	<p>Dry, flat, and gravelly or sandy ground in desert shrub communities where annual and perennial grasses are abundant. Frequent habitats with a mix of shrubs, forbs, and grasses</p>	<p>L</p> <p>None observed; habitat not favorable</p>

Common Name Scientific Name	Status ¹ Federal/CDFG /CNPS	DESCRIPTION OF SPECIES	Habitat	Suitability Of Habitat In Survey Area
Flat-tailed horn lizard <i>Phrynosoma mcallii</i>	PT/-	Closely related to Desert homed lizard (scat indistinguishable); only found in Imperial, Riverside County, Ca and Yuma area, Az. Small round lizard with distinguishing round spots on back. Diet of ants; needs sandy soil, shade bushes to survive.	Desert washes/sandy areas with vegetative cover. Diet of ants	L No habitat; none observed
Fish				
Desert pupfish <i>Cyprinodon macularius</i>	E/E/-	Small, silvery-colored fish with 6 to 9 dark bands on its sides. Grows to a full average length of only 2.5 inches; develop quickly, sometimes reaching full maturity within 2 to 3 months. Although their average life span is 6 to 9 months, some survive more than one year. Pupfish have a short, scaled head with an upturned mouth. The anal and dorsal fins are rounded with the dorsal sometimes exhibiting a dark blotch. The caudal fin is convex at the rear.	Springs, seeps, and slow-moving drains directly draining into Salton Sea in Salton Sink basin and backwaters and sloughs of the Colorado River	L None observed; no habitat; no drains on site;

Common Name Scientific Name	Status ¹ Federal/CDFG /CNPS	DESCRIPTION OF SPECIES	Habitat	Suitability Of Habitat In Survey Area
Razorback Sucker <i>Xyrauchen texanus</i>	Fed/CA: Endangered	One of the largest suckers in North America, can grow to up to 13 pounds and lengths exceeding 3 feet. The razorback is brownish-green with a yellow to white-colored belly and has an abrupt, bony hump on its back shaped like an upside-down boat keel	Colorado River	L None observed; no habitat

USFWS Birds of Conservation Concern					
Common Name	Species Name	Habitat	Potential Onsite	Region 8: Imperial County	National Rating
Bald Eagle	<i>Haliaeetus leucocephalus</i>	Nests on tall trees or on cliffs in forested areas near large bodies of water. Winters in coastal areas, along large rivers, and large unfrozen lakes.	Low Not expected. No tall trees; not observed in area	X	X
Swainson's Hawk	<i>Buteo swainsoni</i>	Breeds in open country such as grassland, shrubland, and agricultural areas. Usually migrates in large flocks often with Broad-winged Hawks. Winters in open grasslands and agricultural areas of Southern America.	Low May migrate through. Not observed in area		X
Peregrine Falcon	<i>Falco peregrinus</i>	Inhabits open wetlands near cliffs for nesting. Also uses large cities and nests on buildings.	Low No open wetlands or nesting area.	X	X
Black Rail	<i>Laterallus jamaicensis</i>	Nests in high portions of salt marshes, shallow freshwater marshes, wet meadows, and flooded grassy vegetation.	Low No salt or freshwater marshes; no vegetation	X	X

Common Name	Species Name	Habitat	Potential Onsite	Region & Imperial County	National Rating
Snowy Plover	<i>Charadrius alexandrinus</i>	Barren to sparsely vegetated sand beaches, dry salt flats in lagoons, dredge spoils deposited on beach or dune habitat, levees and flats at salt-evaporation ponds, river bars, along alkaline or saline lakes, reservoirs, and ponds.	Low No habitat; not observed	X	X
Mountain Plover	<i>Charadrius montanus</i>	Breeds on open plains at moderate elevations. Winters in short-grass plains and fields, plowed fields, and sandy deserts.	Medium Could be found in agricultural fields if planted to Bermuda or alfalfa	X	X
Black Oystercatcher	<i>Haematopus bachmani</i>	Rocky seacoasts and islands, less commonly sandy beaches.	Low No habitat; not observed	X	X
Solitary Sandpiper	<i>Tringa solitaria</i>	Breeds in taiga, nesting in trees in deserted songbird nests. In migration and winter found along freshwater ponds, stream edges, temporary ponds, flooded ditches and fields, more commonly in wooded regions, less frequently on mudflats and open marshes.	Low No habitat; not observed		X

Common Name	Species Code	Habitat	Potential Distribution	Region 8 Imperial County	National Rating
Lesser Yellowlegs	<i>Tringa flavipes</i>	Breeds in open boreal forest with scattered shallow wetlands. Winters in wide variety of shallow fresh and saltwater habitats.	Low No habitat; not observed		X
Upland Sandpiper	<i>Bartramia longicauda</i>	Native prairie and other dry grasslands, including airports and some croplands.	Low No habitat; not observed		X
Whimbrel	<i>Numenius phaeopus</i>	Breeds in various tundra habitat, from wet lowlands to dry heath. In migration, frequents various coastal and inland habitats, including fields and beaches. Winters in tidal flats and shorelines, occasionally visiting inland habitats.	Low	X	X
Long-billed Curlew	<i>Numenius americanus</i>	Nests in wet and dry uplands. In migration and winter found on wetlands, grain fields, lake and river shores, marshes, and beaches.	Low	X	X
Short-billed Dowitcher	<i>Limnodromus griseus</i>	Breeds in muskegs of tundra to timberline, and barely into subarctic tundra. Winters on coastal mud flats and brackish lagoons. In migration prefers saltwater tidal flats, beaches, and salt marshes. Also found in freshwater mud flats and	Low	X	X

Common Name	Species Name	Habitat	Potential Onsite	Region 8 Imperial County	National Rating
Aleutian Tern	<i>Sterna aleutica</i>	flooded agricultural fields. Nest on flat vegetated islands on or near the coast. Vegetation includes dwarf-shrub tundra, grass and sedgemoadows, and coastal marsh. Migration and winter habitat not known, probably pelagic.	Low No habitat; not observed		X
Least Tern	<i>Sterna antillarum</i>	Seacoasts, beaches, bays, estuaries, lagoons, lakes and rivers, breeding on sandy or gravelly beaches and banks of rivers or lakes, rarely on flat rooftops of buildings.	Low No habitat; not observed		X
Gull-billed Turn	<i>Sterna nilotica</i>	Breeds on gravelly or sandy beaches. Inters in salt marshes, estuaries, lagoons and plowed fields, along rivers, around lakes and in freshwater marshes.	Low No habitat; not observed		X
Black Skimmer	<i>Rynchops niger</i>	Breeds in large colonies on sandbars and beaches. Forages in shallow bays, inlets, and estuaries.	Low No habitat; not observed	X	X
Yellow-billed Cuckoo	<i>Coccyzus americanus</i>	Open woodlands with clearings, orchards, dense scrubby vegetation, mainly cottonwood, willow, and adler, often along water.	Low No habitat; not observed	X	X
Black Swift	<i>Cypseloides niger</i>	Nests on steep ledges on cliffs or canyons. Migrates and winters over coastal lowlands.	Low No habitat; no swifts observed in area	X	X

Common Name	Species Name	Habitat	Potential Onsite	Region 8 Imperial County	National Ranking
Costa's Hummingbird	<i>Calypte costae</i>	Primarily low deserts and arid brushy foothills, but also chaparral and coastal sage scrub closer to the coast. Often visits ornamental plantings and feeders in desert communities. In migration and winter frequents a wider variety of habitats, occasionally ranging into pine-oak woodlands in adjacent mountains.	Low No habitat; not observed – no feeders or nectar sources in area	X	X
Calliope Hummingbird	<i>Stellula calliope</i>	Open montane forest, mountain meadows, and thickets of willow and alder. In migration and winter also in chaparral, oak and pine-oak woodlands, deserts, and gardens.	Low No habitat; not observed	X	X
Rufous Hummingbird	<i>Selasphorus rufus</i>	Breeds in a variety of forested habitats where flowers are found. Frequents montane meadows and just about anywhere else with flowers or feeders during migration. Winters primarily in pine and pine-oak forests in Mexico, but most birds wintering farther north are attracted either to flowers or feeders in gardens.	Low No habitat; not observed – no feeders or nectar in area.		X

Common Name	Species Name	Habitat	Potential Effects	Region B Imperial County	National Ranking
Allen's Hummingbird	<i>Selasphorus sasin</i>	Breeds in coastal sage scrub, chaparral, and riparian corridors within coastal forests. In Mexico winters in forest edge and scrub clearings with flowers. The resident population on the mainland of southern California is largely restricted to suburban neighborhoods where feeders and flowers are plentiful.	Low No habitat; not observed. No feeders or nectar in area	X	X
Lewis's Woodpecker	<i>Melanerpes lewis</i>	Breeds in open arid conifer, oak, and riparian woodlands: rare in coastal areas. Winters in breeding habitat, and oak savannas, orchards, and even in towns.	Low No habitat; not observed	X	X
Olive-sided Flycatcher	<i>Contopus cooperi</i>	Montane and northern coniferous forests, at forest edges and openings such as meadows, and at ponds and bogs. Winters at forest edges and clearings where tall trees or snags are present.	Low No habitat; not observed	X	X
Willow Flycatcher	<i>Empidonax trillii</i>	Breeds in moist, shrubby areas, often with standing or running water. Winters in shrubby clearings and early successional growth.	Low No habitat on site; not observed	X	X
Loggerhead Shrike	<i>Lanius ludovicianus</i>	Open or brushy areas.	Low No prey base available on site May be seen passing through area	X	X

Common Name	Species Name	Habitat	Potential Onsite	Region 9 Imperial County	National Rating
Bell's Vireo	<i>Vireo bellii</i>	Dense, low, shrubby vegetation generally early successional stages in riparian areas, brushy fields, young second-growth forest or woodland, scrub oak, coastal chaparral, and mesquite brushlands, often near water in arid regions.	Low No habitat; not observed	X	X
Gray Vireo	<i>Vireo vicinior</i>	Found in desert scrub, mixed oak-juniper and pinyon-juniper woodlands, dry chaparral, and thorn scrub in hot, arid mountains and high-plains.	Low No habitat; not observed	X	X
LeConte's Thrasher	<i>Toxostoma lecontei</i>	Desert scrub, mesquite, tall riparian brush and, locally, chaparral.	Low No habitat; not observed	X	X
Yellow Warbler	<i>Dendroica petechia</i>	Breeds in wet, deciduous thickets, especially in willows and alder. Also in shrubby areas, old fields, gardens and orchards. In southern Florida and farther south, found in mangroves.	Low No habitat; not observed	X	
Common Yellowthroat	<i>Geothlypis trichas</i>	Thick vegetation from wetlands to prairies to pine forests. Frequently near water.	Low No habitat; not observed	X	
Rufous-winged Sparrow	<i>Aimophila carpalis</i>	Found in flat areas of tall desert grass mixed with brush and cactus, and thorn scrub.	Low No habitat; not observed		X

Common Name	Species Name	Habitat	Potential Onsite	Region 8 Imperial County	National Ranking
Brewer's Sparrow	<i>Euphagus cyanocephalus</i>	Found in a variety of habitats, but prefers open, human-modified areas, such as farmland, fields, residential lawns, and urban parks.	Low No habitat; not observed	X	X
Black-chinned Sparrow	<i>Spizella atrogularis</i>	Arid brushland, commonly in tall and fairly dense sagebrush, and dry chaparral. Often in rocky, rugged country from sea level to around 8,900 ft (2700m).	Low No habitat; not observed	X	X
Tricolored Blackbird	<i>Agelaius tricolor</i>	Breeds in marsh vegetation, particularly cattails, near grain fields, riparian scrubland, and forests, but always near water. Dairies and feedlots also commonly used for foraging. Urban and suburban areas occasionally utilized, particularly park lawns. Cultivated lands also suitable for foraging. Large night-time roosts form during nonbreeding season in cattail marshes near foraging grounds.	Low No habitat; not observed	X	X
Lawrence's Goldfinch	<i>Carduelis lawrencei</i>	Prefers dry interior foothills, mountain valleys, open woodlands, chaparral, and weedy fields. Often found near isolated water sources such as springs and cattle troughs.	Low No habitat; not observed	X	X

CNPS Species or Community Level	
G1 = Less than 6 viable element occurrences (EOs) OR less than 1,000 individuals OR less than 2,000 acres.	
G2 = 6-20 EOs OR 1,000-3,000 individuals OR 2,000-10,000 acres.	
G3 = 21-80 EOs OR 3,000-10,000 individuals OR 10,000-50,000 acres.	
G4 = Apparently secure; this rank is clearly lower than G3 but factors exist to cause some concern; i.e., there is some threat, or somewhat narrow habitat.	
G5 = Population or stand demonstrably secure to ineradicable due to being commonly found in the world.	
State Ranking	
The state rank (S-rank) is assigned much the same way as the global rank, except state ranks in California often also contain a threat designation attached to the S-rank.	The R-E-D Code contains information on Rarity, Endangerment, and Distribution, ranked as a 1, 2, or 3 for each value (as below). This code was originally known as the R-E-V-D Code (through the 3rd edition 1980), and the V (Vigor) was removed in the 4th edition (1984).
S1 = Less than 6 EOs OR less than 1,000 individuals OR less than 2,000 acres	R - Rarity
S1.1 = very threatened	1 – Rare, but found in sufficient numbers and distributed widely enough that the potential for extinction is low at this time
S1.2 = threatened	2 – Distributed in a limited number of occurrences, occasionally more if each occurrence is small
S1.3 = no current threats known	3 – Distributed in one to several highly restricted occurrences, or present in such small numbers that it is seldom reported
S2 = 6-20 EOs OR 1,000-3,000 individuals OR 2,000-10,000 acres	E - Endangerment
S2.1 = very threatened	1 – Not very endangered in California
S2.2 = threatened	2 – Fairly endangered in California
S2.3 = no current threats known	3 – Seriously endangered in California
S3 = 21-80 EOs or 3,000-10,000 individuals OR 10,000-50,000 acres	D - Distribution
S3.1 = very threatened	1 – More or less widespread outside California
S3.2 = threatened	2 – Rare outside California
S3.3 = no current threats known	3 – Endemic to California
S4 = Apparently secure within California; this rank is clearly lower than S3 but factors exist to cause some concern; i.e. there is some threat, or somewhat narrow habitat. NO THREAT RANK.	
S5 = Demonstrably secure to ineradicable in California. NO THREAT RANK.	

Sources: CDFG/CNDDDB 2018, California Wildlife 2016; CNPS 2018; USFWS, 2018	
State/CDFG:	¹ Status: Federal;
E = Listed as an endangered species; or previously known as "rare, fully protected"	E = Listed as an endangered species
T = Listed as a threatened species	T = Listed as a threatened species
SC = species of special concern (designation intended for use as a management tool and for information; species of special concern have no legal status (www.dfg.ca.gov/wildlife/species/ssc/birds.html))	C = Candidate for listing
CNPS (California Native Plant Society):	D = Delisted
1B = Rare, threatened, or endangered in California or elsewhere	PD = Proposed for delisting/PT = Proposed for threatened status
2= Plants rare, threatened, or endangered in Ca, but more common elsewhere	
3=Plants about which more information is needed	
Habitat Suitability Codes: H = Habitat is of high suitability for this species M = Habitat is of moderate suitability for this species L = Habitat is of low suitability for this species	

**APPENDIX B
PHOTOGRAPHS**

PHOTOGRAPHS



1. Northwest corner looking south; project (bermudagrass field) on left; adjacent bermudagrass field

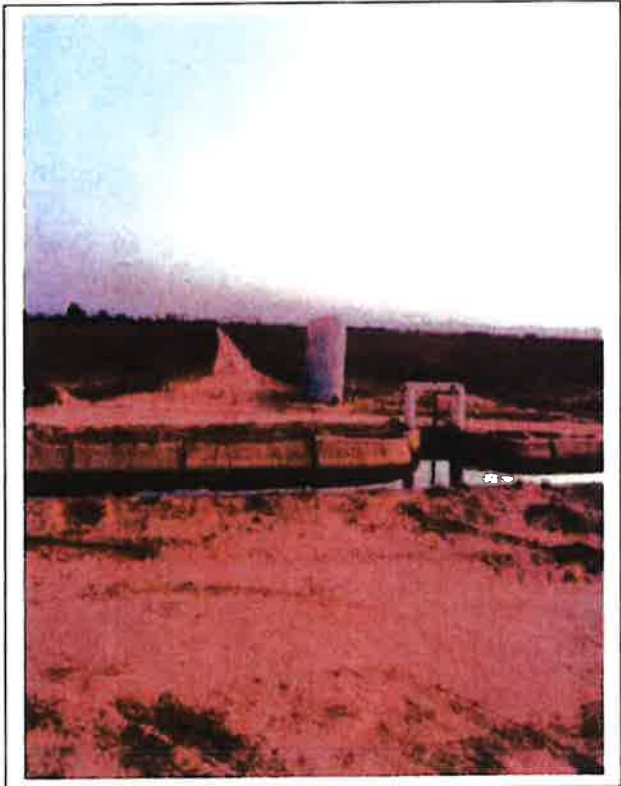

2. Northwest corner looking south to adjacent Bermuda fields

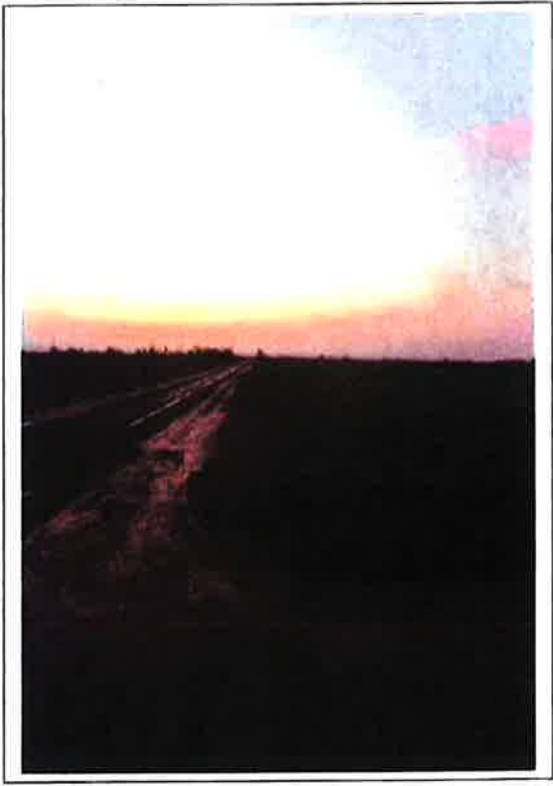

3. Site looking north; IID drain on right

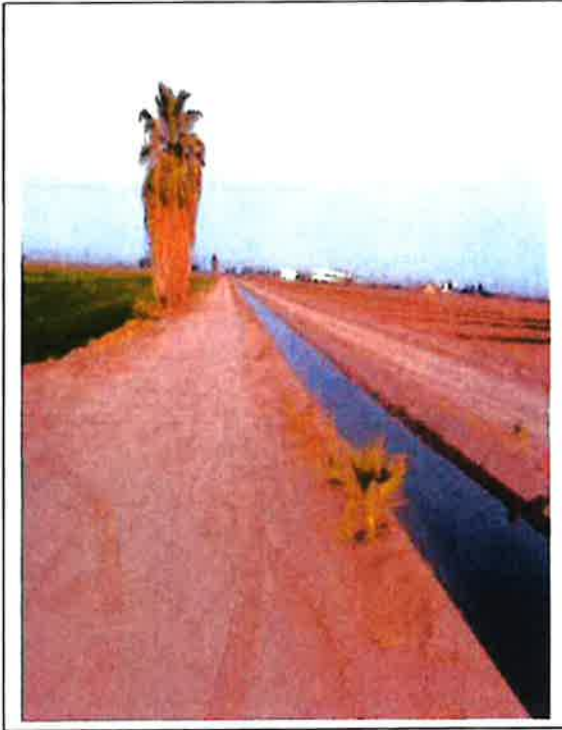

4. Site; IID canal and disked field to north of site

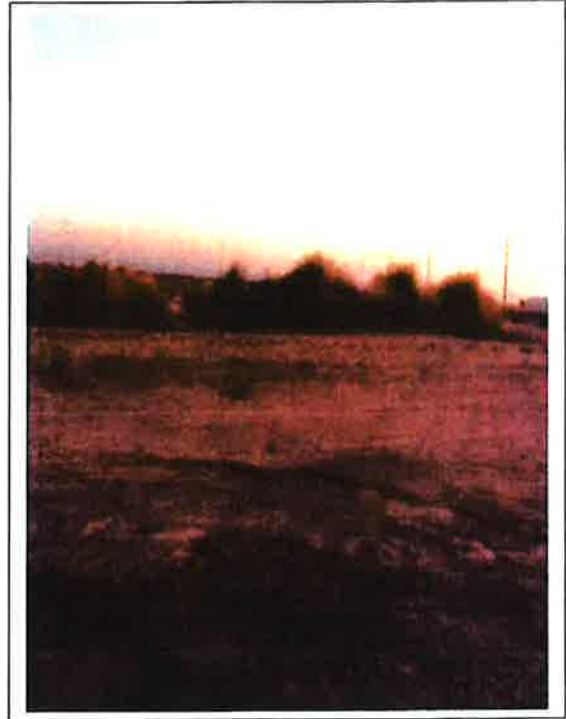

5. Abandoned lot to north of site; ruderal quail bush vegetation

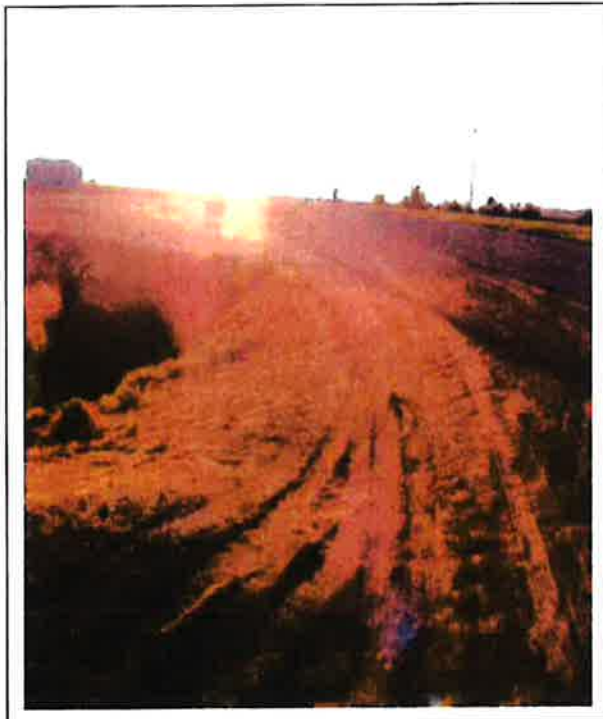

6. Railroad tracks and IID drain to east of site

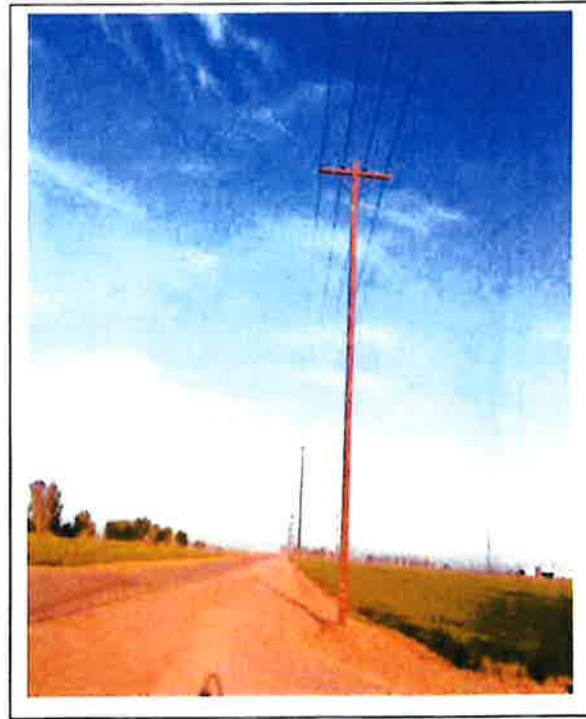

7. Bermudagrass fields adjacent to site

**APPENDIX C
VICINITY MAP/
BIOLOGICAL SURVEY
MAP**

PROJECT STATEWIDE LOCATION



PROJECT REGIONAL LOCATION

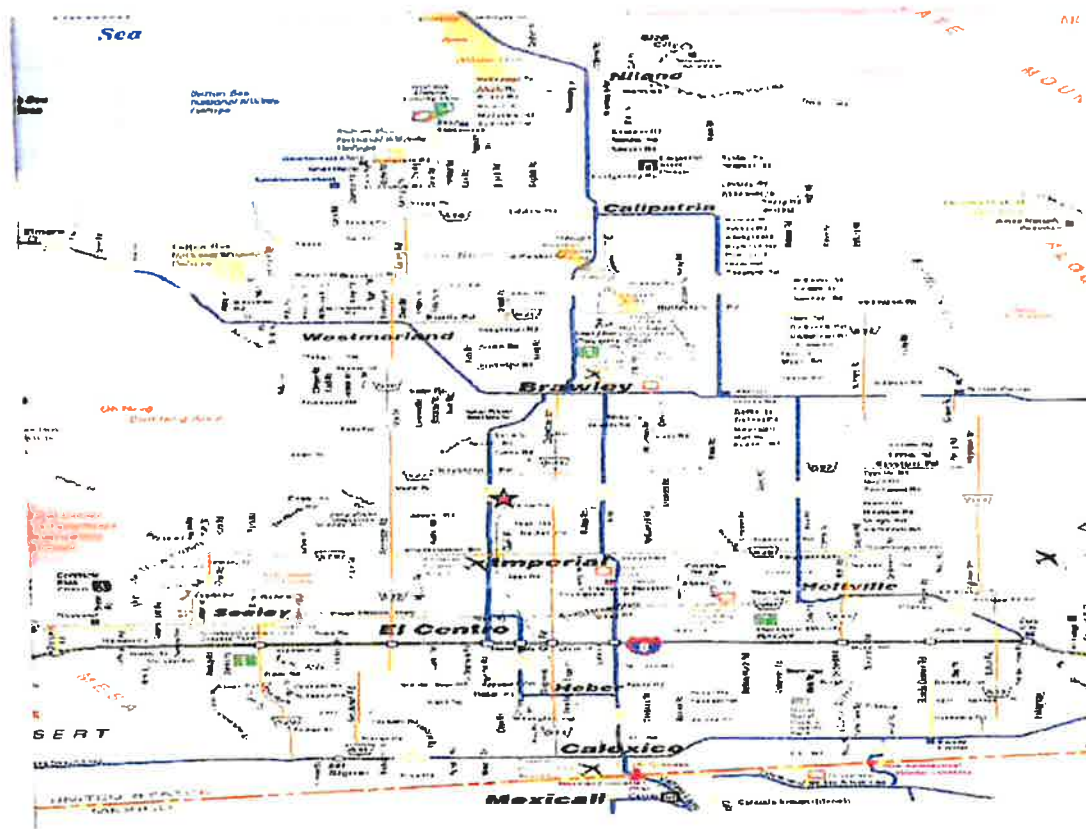

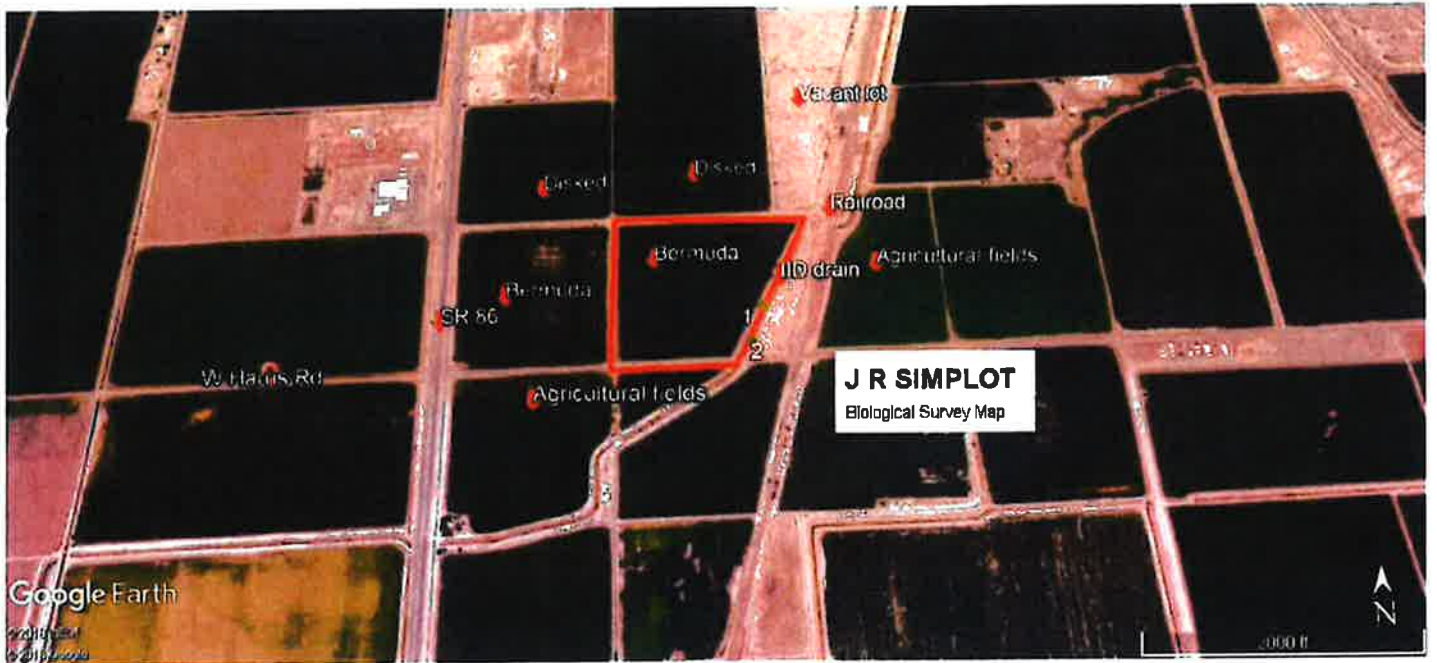

APPENDIX D QUALIFICATIONS

GLENNA MARIE BARRETT

PO Box 636 Imperial, California 92251 (760) 425-0688
glennabarrett@outlook.com

PROFILE

Organized and focused individual, adept at implementing multifaceted projects while working alone or as an integral part of a team. Skilled in client/employee communications, report preparation, program analyses and development. Cost conscious, safety oriented and empathetic. A strong communicator with excellent interpersonal skills, which allows development of rapport with individuals on all levels. A sound professional attitude, strong work ethic and pride in personal performance.

WORK EXPERIENCE

Senior Biologist/Partner, Barrett's Biological Surveys, GP. Imperial County, CA April 2016-currently. Principal Biological Consultant, Barrett Enterprises. Imperial, CA December 2001 - currently. Compile information and complete local, state, and federal government forms; such as conditional use permits, reclamation plan applications, Financial Assurance Cost Estimates, zone changes, CEQA, Environmental Evaluation Committee responses, and 501 (c)(3) tax exemption applications. Act as liaison between local businesses and local, state, and federal government agencies. Certified to survey for Flat-Tailed Horned Lizards in California and Arizona. Certified to survey the Desert Tortoise.

Kruger- Environmental Compliance Coordinator (ECC) for Seville Solar Complex for a 626-acre solar farm in Imperial County, CA. Compiled and submitted data and reports for APCD such as equipment lists and man hours, water hours for dust suppression; Planning reports such as weekly monitoring reports and scheduling with the third party monitor for work on BLM land; Assisted in writing the Emergency Response Action Plan; CDFW quarterly reports for the Incidental Take Permit for the Flat Tail Horned Lizard (FTHL), CNDDDB reports, FTHL Observation Data Sheets, site tours and any other information required by CDFW; Agriculture Commissioner's Office quarterly reports; provided the hazardous reporting information for the CERS online reporting system; assisted writing the FTHL ITP; trained new hires; contacted various local businesses for different on-call services; also provided any updates for plans and schedules necessary throughout the life of the project; etc. (January 2015- March 2016).

Grant writing experience: Awarded two grants for BUOW educational programs for \$15,000 each from Imperial Valley Community Foundation. Awarded \$35,700 for a total of \$75,000 with matching funds to establish the Imperial Valley Small Business Development Center with the Imperial Regional Alliance. Awarded \$450,000 from the California Public Utilities Commission for a broadband connectivity initiative in Imperial County with Imperial Regional Alliance and Imperial Valley Economic Development Corporation (IVEDC). Awarded \$450,000 in grant funding from USDA for the RMAP program with IVEDC being the recipient of the funds. Assisted in writing two grants with the Imperial County Film Commission (ICFC). The first grant written with the ICFC from the Imperial Valley Community Foundation for educational film classes at the 2017 Film Festival, which was awarded for \$5,000. Another grant co-written with the ICFC from the Imperial Irrigation District Local Entity Grant for office assistants, etc.

FIELD EXPERIENCE

Ms. Barrett has done the field work and contributed to the required reports for the following projects:
• **8ME-Burrowing Owl Monitoring and training for the Mount Signal Solar Three Project** in Calexico, CA (April 2016-currently)

NAF-EC – FTHL monitoring for Holtville Airstrip project with USMC personnel to widen a six-mile BLM road and re-strip an airfield. Monitored and consulted with above-mentioned agencies for FTHL. (October 2014)

- **Sol Orchard** - El Centro, CA: Successfully completed BUOW relocation and artificial burrow installation for six burrows.
- **Burrtec- FTHL Surveys** in Salton City, CA: Team leader for eight people to complete a pre-construction site sweep for 320 acres in Imperial County.
- **Applied Biological Consulting- Approved Biological Monitor on DPV2:** The 500kV transmission line traverses approximately 153 mi from Bythe, CA to Menifee in Riverside County, CA. Crossing private, state and Federal lands, such as the Bureau of Land Management [BLM], U.S. Forest Service [USFS]. (November 2011 to May 31, 2013)

EDUCATION AND TRAINING

Received Bachelor of Science in Business Administration with a focus on Management, along with Economics and Leadership minors, December 2000. Humboldt State University, Arcata, CA.
Special Status/listed species observed/ identified, surveyed, monitored and/or relocated: Mohave desert tortoise, Coachella valley milkvetch, Desert kit fox, Mountain lion, Coachella valley fringe toed lizard, Mohave fringe toed lizard, Stephen's kangaroo rat, Mohave ground squirrel, Coast horned lizard, Flat-Tail Horned lizard, Burrowing Owl.

Extensive knowledge in southwestern United States, non-migratory and migratory avian biology and ecology. Strong knowledge of common Flora and Fauna communities associated with Southern California and surrounding environs. CEQA, NEPA, California Endangered Species Act (CESA) and Federal Endangered Species Act (ESA) knowledge gained through work experience. I have excellent analytical skills, multi-tasking and writing abilities. My past work experience has provided me with many years of hands on experience working with and managing others to find practical solutions to solve problems and achieve common goals.

CERTIFICATIONS/ WORKSHOPS

- FTHL Workshop, 2008 El Centro BLM office.
- USFW Desert Tortoise Egg Handling Desert Tortoise Council Survey Techniques Workshop Certificate, 2008 and 2010.
- Anza Borrego State Park Wildflower Identification Workshop, 2010.
- Southwest Willow Flycatcher Workshop Kernville, CA, 2010.
- SCE TRTP Construction Monitoring Training Class and WEAP Redlands, CA 2011.
- DPV2 Construction Monitoring Training Class and WEAP Santa Ana, CA 2011.
- Helicopter flight trained on DPV2, 2012.
- Certified to handle/ move venomous snakes on DPV2, 2012.
- Bat monitoring with Ms. Pat Brown BLM El Centro, CA Office, 2010.
- Salton Sea International Bird Festival 2007 Coordinator
- Mountain Plover/ Long-billed Curlew surveys, L.A. Museum of Natural History.
- Current First Aid certification to 2016.
- Presented at the Fourth Annual BUOW Symposium in Pasco, Washington, 2014.
- Board Member- Colorado River Citizens Forum, 2014-2016.
- BUOW Educational outreach grantee from IVCF, interacting with IID, IVROP, ICFB, Ag Commissioner's Office, 2015.
- Friends of the Sonny Bono National Wildlife Refuge, Member 2015

Danielle Figueroa

1023 Palmview Avenue El Centro, CA 92243
danifig2012@outlook.com (760) 791-4706

SUMMARY OF QUALIFICATIONS:

Ability to work well with others with a variety of different personalities. Compassionate and dedicated to helping others. Dependable and reliable.

SKILLS AND ABILITIES:

Over seven years of experience in biological surveying and construction monitoring for Burrowing Owls, Flat tail horned lizard, MBTA species, flora and general biological surveys. Adept at using GPS, binoculars, Trimble's, and other survey techniques.

EXPERIENCE

- Midway 2 mortality surveys in Calipatria, CA. October 2017 to currently.
- Mount Signal Solar 3 BUOW surveys and monitoring in Calexico, CA. October 2017 to currently.
- Mount Signal Solar 1 BUOW Surveys. Identify previous and new BUOW burrows for five years for a solar farm in Calexico, CA. August 2015- currently.
- Midway 2 Solar Farm BUOW Surveys in Calipatria, CA. July 2015 to currently.
- Brown Field Airport BUOW survey in San Diego, CA. March 2018
- Monitored a movie shoot in Imperial County for Sidewinders off Wheeler Road. June 2015
- Sun Edison BUOW Surveys. Completed multiple buow clearance surveys. December 2014 to May 2015
- Burrtec FTHL Clearance Survey. Completed a FTHL clearance survey of 320 acres in Imperial County.
- Worthington Road Bridge MBTA Construction Monitoring- Monitored construction activities to protect swallows in Imperial County. June-2013.
- Carter Road MBTA Construction Monitoring- Monitored construction activities to protect swallows in Imperial County. May- 2013.
- 8Minute Energy Iris Cluster- Biological technical survey to identify zoological and botanical species. April-July 2013
- 8Minute Energy Mount Signal/ Calexico Solar Farm Cluster- Field assistant for surveys for BUOW and MBTA species. Dec 2010- Jan 2011

EDUCATION

- Imperial Valley College – El Centro, CA 8/2012 – 3/2013
- California Nurses Educational Institute – Palm Springs, CA Certified Nursing Assistant 4/2012 – 7/2012
- Riverside Community College- Moreno Valley, CA 8/2008-1/2009

Cultural Resource Inventory Report (dated March 2019)

**Cultural Resource Inventory Report
J.R. Simplot Fertilizer Terminal Project
Imperial County, California**

Prepared for:

Dubose Design Group
1065 State St.
El Centro, CA 92243

Prepared by:

Douglas Drake, M.A., RPA
Associate Archaeologist

and



Stephen Harvey, M.A., RPA
Principal Investigator

ASM Affiliates, Inc.
2034 Corte del Nogal
Carlsbad, California 92011

USGS 7.5-minute El Centro Quadrangle; approximately 40 acres
Keywords: Imperial County, Niland Railroad

PN 31500
March 2019

EEC ORIGINAL PKG

TABLE OF CONTENTS

Chapter	Page
MANAGEMENT SUMMARY	iii
1. INTRODUCTION	1
PROJECT DESCRIPTION	1
SUMMARY	4
STUDY PERSONNEL	4
2. SETTING	5
NATURAL SETTING	5
Geology	5
Climate	5
Topography	5
Flora and Fauna	5
Paleoenvironments	6
CULTURAL SETTING	7
Prehistory	7
Ethnography	12
History	17
3. METHODS AND RESULTS	25
RECORDS SEARCH.....	25
SURVEY	26
Methods.....	26
Field Conditions and Results	26
4. MANAGEMENT RECOMMENDATIONS	29
REFERENCES	31
APPENDICES	39
APPENDIX A: SCIC Documentation.....	41
APPENDIX B: NAHC Documentation	43

LIST OF FIGURES

	Page
Figure 1. J.R. Simplot Fertilizer Terminal Project vicinity map.	1
Figure 2. J.R. Simplot Fertilizer Terminal Project area on the USGS Brawley 7.5' Quadrangle map.	2
Figure 3. J.R. Simplot Fertilizer Terminal Project area and 0.5-mile record search radius on aerial photograph.	3
Figure 4. View of the north west corner of the proposed Project area, facing north west.	27
Figure 5. View of the eastern side of the proposed Project area, facing north west.	28

LIST OF TABLES

	Page
Table 1. Previous Cultural Resource Surveys within the 0.5-Mile Record Search Radius.	25
Table 2. Previously Recorded Cultural Resources within the 0.5-Mile Record Search Radius.	26

MANAGEMENT SUMMARY

J.R. Simplot proposes to construct a fertilizer terminal on an approximately 40-acre parcel that is currently zoned for medium industrial use. The Project is located within Assessor Parcel Number (APN) 040-340-043, at the northwestern corner of the intersection of the Southern Pacific railway line and Harris Road, just north of the City of Imperial, in Imperial County, California. The Project is shown on the USGS 7.5' Brawley Quadrangle, within Township 14 South Range 14 East, Section 31. ASM Affiliates was contracted by DuBose Design Group to conduct a cultural resources survey and records search for the proposed Project.

This study was performed in compliance with the California Environmental Quality Act (CEQA) and the cultural resource management regulatory compliance component of the County of Imperial General Plan (Imperial County Planning and Development Services Department 2015). Imperial County is the lead agency for the proposed Project.

A record search at the South Coastal Information Center (SCIC) of the California Historical Resources Information System (CHRIS), was performed for the project area and a 0.5-mile buffer around it on January 28, 2019. One cultural resource has been previously recorded within the record search radius. No previously recorded cultural resources were identified within or adjacent to the Project area. A record search of the Sacred Lands File held by the Native American Heritage Commission (NAHC) was conducted on January 11, 2019 and returned positive results. A systematic pedestrian survey of the project area was performed by ASM Associate Archaeologist Douglas Drake, M.A., RPA, and Native Monitor Jonathon Jones of Campo Kumeyaay Nation on February 12, 2019. No cultural resources were identified within the Project area during the pedestrian archaeological survey.

No prehistoric or historic cultural resources were identified within the Project area either during the record searches or during the pedestrian survey. The Niland to Calexico railroad grade located within 0.5-mile but outside the Project area will not be impacted by the proposed Project. Based on these findings, there will be no impact to historical resources associated with the development of the proposed J.R. Simplot Fertilizer Terminal Project. In accordance with CEQA, cultural resource management regulatory compliance activities are complete, and no further cultural resource management field work is recommended. The Ewiiapaayp Tribe should be contacted, along with the 19 other Native American individuals and organization listed by the NAHC for further information regarding the proposed project area including the potential for sacred sites, Tribal Cultural Resources and/or Traditional Cultural Properties in or in the vicinity of the Project area, in accordance with Senate Bill (SB) 52 requirements.

1. INTRODUCTION

This report documents the results of a cultural resource survey conducted for the proposed J.R. Simplot Fertilizer Terminal Project (Project), which was conducted to provide compliance with the California Environmental Quality Act (CEQA) and the cultural resource management regulatory compliance component of the County of Imperial General Plan (Imperial County Planning and Development Services Department 2015). Imperial County is the lead agency for the proposed Project. The purpose of the study was to identify any cultural resources present within the project area that are significant under CEQA and are eligible for listing in the California Register of Historical Resources (CRHR).

PROJECT DESCRIPTION

J.R. Simplot proposes to construct a fertilizer terminal on an approximately 40-acre parcel that is currently zoned for medium industrial use. The Project is located within Assessor Parcel Number (APN) 040-340-043, at the northwestern corner of the intersection of the Southern Pacific railway line and Harris Road, just north of the City of Imperial, in Imperial County, California. The Project is shown on the USGS 7.5' Brawley Quadrangle, within Township 14 South Range 14 East, Section 31 (Figures 1-3). The J.R. Simplot Company proposes to construct a fertilizer warehouse/terminal where fertilizer will be received, warehoused and shipped. The proposed Project site will receive both solid and liquid fertilizers via Southern Pacific Railroad, and distribute the fertilizer via trucks. The facility will have the capacity to store approximately 14,000 tons of eight different dry/solid product segregations, and 15,000 tons of four different product segregations of liquid fertilizer. Both the liquid and solid fertilizer will be shipped via truck to recipients.

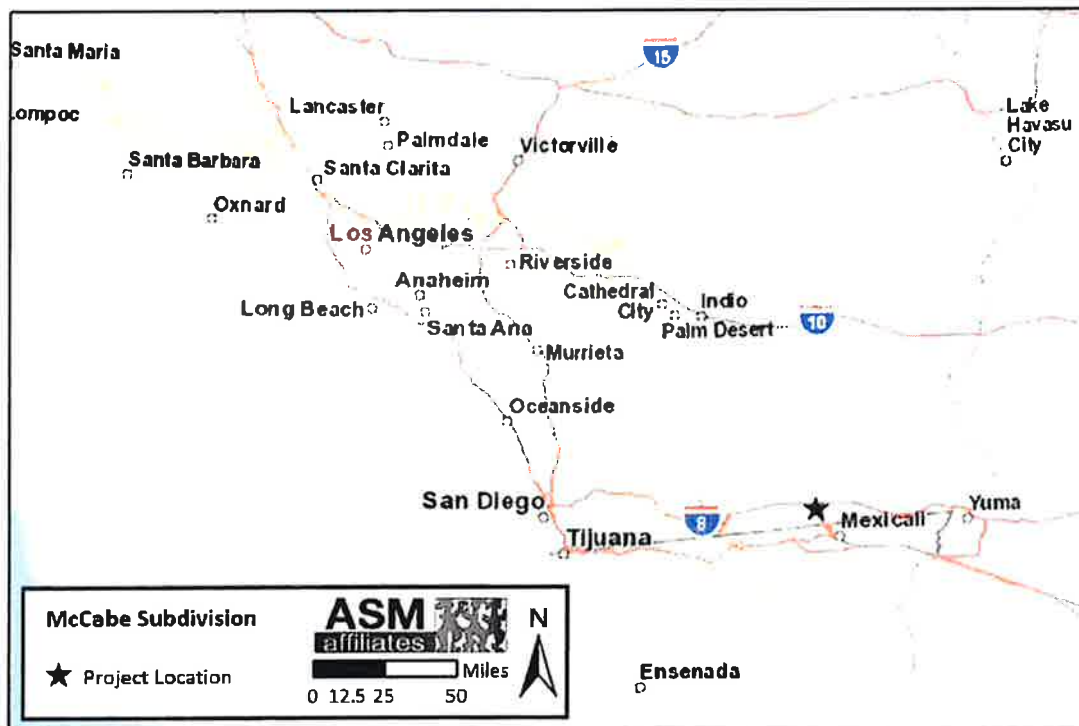

Figure 1. J.R. Simplot Fertilizer Terminal Project vicinity map.

1. Introduction

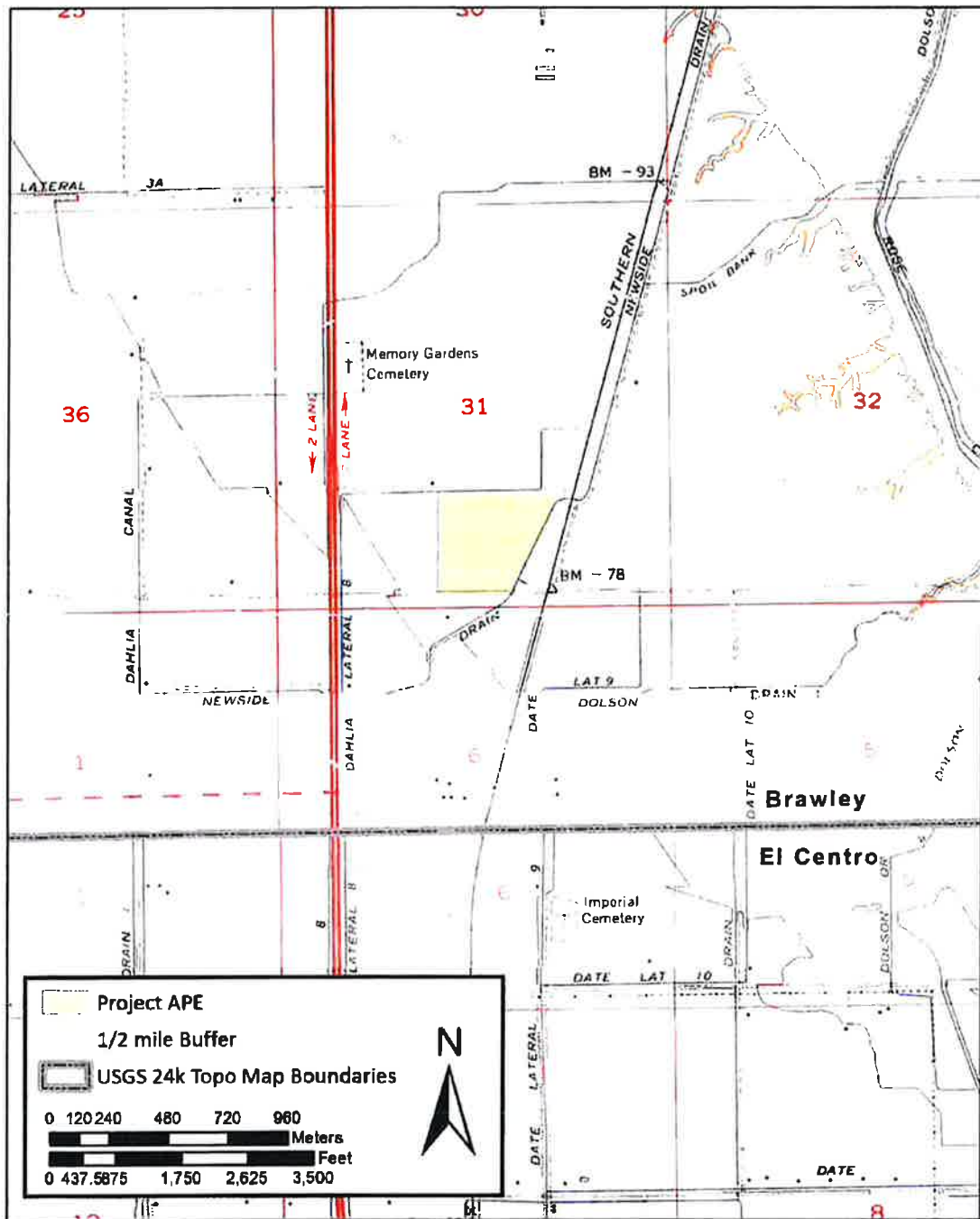

Figure 2. J.R. Simplot Fertilizer Terminal Project area on the USGS Brawley 7.5' Quadrangle map.

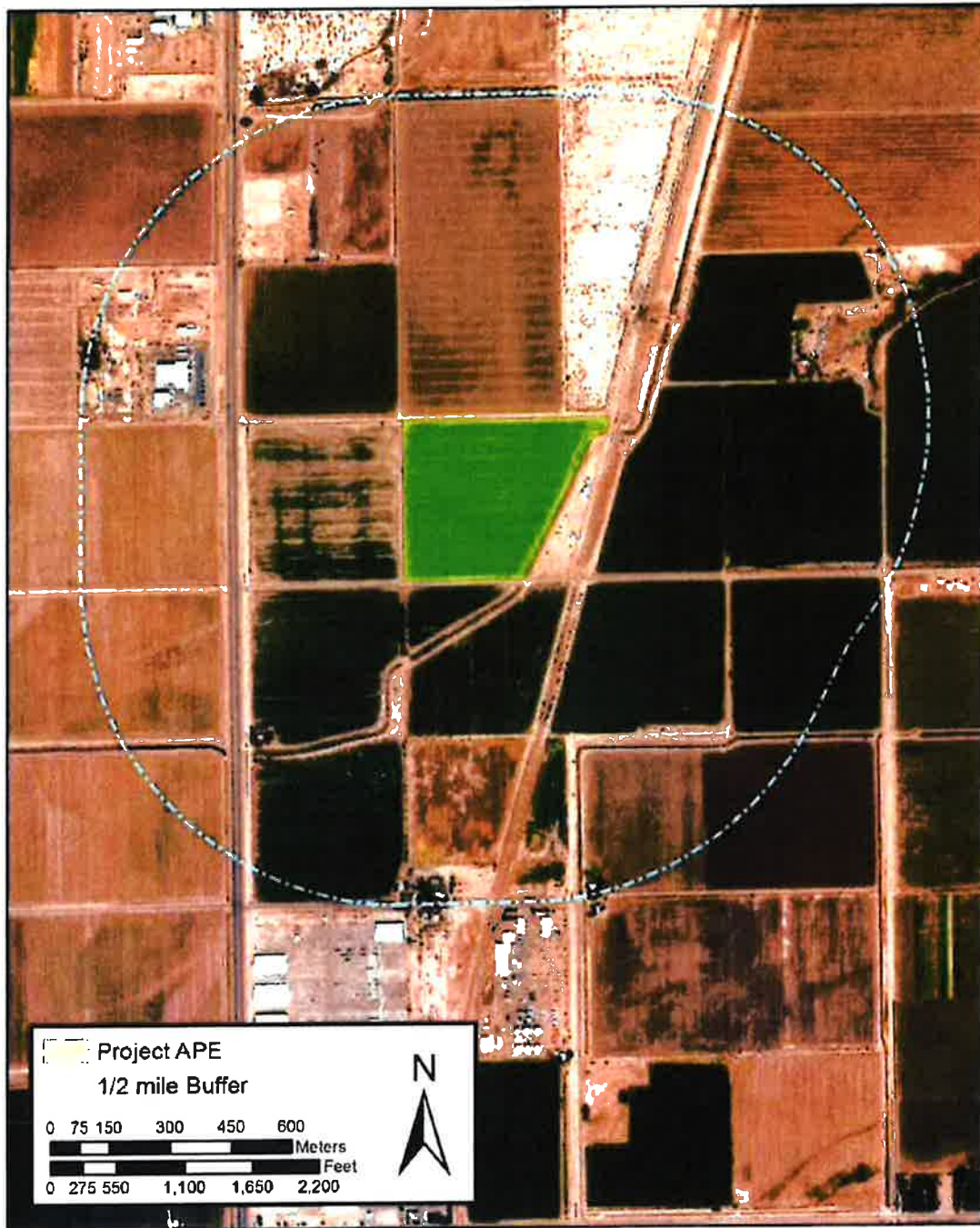

Figure 3. J.R. Simplot Fertilizer Terminal Project area and 0.5-mile record search radius on aerial photograph.

SUMMARY

A record search at the South Coastal Information Center (SCIC) of the California Historical Resources Information System (CHRIS), was performed for the project area and a 0.5-mile buffer around it. No previously recorded cultural resources were identified within or adjacent to the Project area. One cultural resource has been previously recorded within the record search radius. A record search of the Sacred Lands File held by the Native American Heritage Commission (NAHC) was conducted and returned positive results. "Positive results" indicates that there is specific site information in the Sacred Lands File (SLF) regarding issues of concern for Native Americans associated with the project area, and that there may be a potential for sacred sites, Tribal Cultural Resources and/or Traditional Cultural Properties in or in the vicinity of the Project area. A systematic pedestrian survey of the project area was performed and no cultural resources were identified within the Project area.

No prehistoric or historic cultural resources were identified within the Project area either during the record searches or during the pedestrian survey. The Niland to Calexico railroad grade located within 0.5-mile but outside the Project area will not be impacted by the proposed Project. Based on these findings, there will be no impact to historical resources associated with the development of the proposed J.R. Simplot Fertilizer Terminal Project. In accordance with CEQA, cultural resource management regulatory compliance activities are complete, and no further cultural resource management field work is recommended. The Ewiiapaayp Tribe should be contacted, along with the 19 other Native American individuals and organization listed by the NAHC for further information regarding the proposed project area including the potential for sacred sites, Tribal Cultural Resources and/or Traditional Cultural Properties in or in the vicinity of the Project area, in accordance with Senate Bill (SB) 52 requirements.

Following this introduction, this report consists of Chapter 2, the archaeological/historical context of the survey area; Chapter 3, survey design and field methods; survey results and fieldwork summary; and Chapter 4, cultural resource management recommendations.

STUDY PERSONNEL

The following individuals were instrumental in conducting the field investigations, research, analysis, and producing this report for the proposed Project:

Stephen Harvey, ASM Senior Archaeologist (M.A., Anthropology, Archaeology Focus, San Diego State University), RPA, served as Project Manager and Principal Investigator.

Douglas Drake, ASM Associate Archaeologist (M.A., Anthropology, Washington State University), RPA, served as Field Director.

The South Coastal Information Center (SCIC) performed the record search of the California Historical Resources Information System (CHRIS).

The Native American Heritage Commission (NAHC) performed the record search of the Sacred Lands File.

2. SETTING

NATURAL SETTING

Geology

The surface geology of the Project area is relatively simple, consisting entirely of Quaternary lake deposits (Morton 1977; Jennings 1967). A notable deviation from this pattern is the presence of Obsidian Butte and other Quaternary rhyolitic volcanics to the north east of the Project area. Obsidian Butte was a regionally important prehistoric resource for the manufacture of flaked stone tools, particularly projectile points.

Climate

The Project area is located in the low-lying Colorado Desert, in the rain shadow of the Peninsular Ranges, and consequently its climate is generally very hot and dry. In Brawley, mean maximum temperatures in July reach 107°F (42°C), and December-January mean maximum temperatures are about 70-72°F (21-22°C), while low temperatures rarely fall below freezing. Annual precipitation amounts to only 3.1 in. (7.9 cm), spread through much of the year in the south but becoming more strongly concentrated during the winter in the north.

Topography

The Project area lies in the Salton Basin within the Colorado Desert. The basin is a large fault-framed basin at the interface of portions of the North American and Pacific tectonic plates. The trough has been filled by immense quantities of colluvial and alluvial sediments that are in some places up to 20,000 ft. (6,000 m) deep (Morton 1977). Natural northward diversions of the Colorado River into the Salton Trough resulted in the periodic formation of an extensive freshwater lake known as Lake Cahuilla that drowned the locations now occupied by the modern sites of Indio, Brawley, El Centro, and Mexicali. Lake Cahuilla covered the entire project area, which lies approximately 230 ft. below sea level. The Project area is northeast of the confluence of the current alignment of the New River and the Salton Sea.

Flora and Fauna

Natural plant and animal life in the western Colorado Desert is characteristic of the Lower Sonoran Life Zone. Major vegetation communities include creosote bush scrub and saltbush scrub. Individual plants in these vegetation communities are widely spaced and provide little ground cover. Some portions of the desert have no visible plants and consist of shifting sand dunes or nearly sterile salt flats. Depending on the duration and intensity of rainfall, perennial and annual species will vary. Currently the project area is in use as an agricultural field and no native plant and animal life is present.

Native plant communities, which may have been present in the Project area prior to its use as an agricultural field include Creosote bush scrub and Saltbush scrub (Jaeger 1965). These plant communities were of economic importance to the Native Americans who occupied the region (Bean and Saubel 1972). Pollen and carbonized remains that commonly occur in the better-preserved archaeological sites include saltbush, seepweed, mesquite (*Prosopis glandulosa*), cactus, and buckwheat. When Lake Cahuilla was present, several additional wetland plants were available and important to the native economy, including cattail (*Typha latifolia*), bulrush (*Scirpus* sp.), and arrowweed (*Pluchea sericea*).

The most common low-desert animals of economic importance to native peoples were black-tailed jackrabbits (*Lepus californicus*), cottontails (*Sylvilagus audubonii*), ground squirrels and other rodents, various lizards, pronghorn antelope (*Antilocapra americana*), and mule deer (*Odocoileus hemionus*). During stands of Lake Cahuilla, prehistoric people were especially attracted to the western Colorado Desert

2. Setting

because of the availability of various Colorado River fish species such as bonytail chub (*Gila elegans*), razorback sucker (*Xyrauchen texanus*), Colorado pike minnow (*Ptychocheilus lucius*), and striped mullet (*Mugil cephalus*). Various migratory waterfowl were also caught, including coots (*Fulica americana*) and ducks (Jaeger 1965).

During the archaeological survey no native animals were noted in the Project area.

Paleoenvironments

Pleistocene and Holocene Climate and Biota

Evidence of earlier environmental conditions in the Colorado Desert is still very limited. Pollen-bearing, stratified deposits from caves or lakebeds are not as common in the Colorado Desert as in the Great Basin, where most of the desert climatic reconstructions have been based. The best information comes from investigations of plant microflora in fossil packrat (*Neotoma* sp.) middens along the Colorado and Gila rivers and extending across the Sonoran Desert to the east (King and Van Devender 1977; Van Devender 1990; Van Devender and Spaulding 1979, 1983). Of greatest relevance to the low elevations of the Colorado Desert are the stratified fossil packrat middens in the Wellton Hills (160-180 m), Hornaday Mountains (240 m), Butler Mountains (240-255 m), Picacho Peak (300 m), Tinajas Altas Mountains (330-580 m), and Whipple Mountains (320-525 m). Van Devender (1990) provided an authoritative review and reconstruction of climate and vegetation over the last 14,000 years from these investigations, summarized below.

The data from below 1,000 ft. (300 m) indicate that the lower Colorado River Valley, and presumably the Salton Trough as well, may indeed have been a refugium for lower Sonoran Creosote Scrub habitat during the Pleistocene, but also containing the frost-resistant Mojavean species (Cole 1986). The region would have resembled Joshua Tree National Monument until 9000-10,000 B.P., when the Sonoran-Mojave desert boundary moved north to its present location and modern vegetation associations were established. Mojavean species persisted at some locations in the early Holocene and indicate a transitional period from colder and wetter to more xeric conditions. Some investigators have interpreted the paleoenvironmental record to suggest that El Niño effects were more intense and stronger at this time, but with little effect from summer monsoons in the Salton Trough. The extent to which very hot and dry extremes affected the lowlands remains problematical, and such effects may have been mitigated to some extent by the Colorado River and by possible infillings of Lake Cahuilla. The same may be true of late Holocene climatic fluctuations such as the Medieval Climatic Anomaly, which lasted from around A.D. 800 through the great drought of A.D. 1209-1350 (Jones et al. 1999). Drought impacts on mountain and coastal areas are now well established from tree-ring analyses, and there may well have been direct and indirect ramifications for desert dwellers on the western side of the Salton Trough. Episodes of cooler and wetter conditions are also documented through a number of paleoenvironmental indices and in historical accounts. The most recent episode was the Little Ice Age, the effects of which were felt between about A.D. 1450 and 1850.

At higher elevations, between 1,000 and 2,000 ft. (300-600 m), midden analyses indicate a juniper woodland habitat in the Late Pleistocene between 22,000 and 11,000 B.P. These xeric woodlands continued through the early Holocene, finally ascending to higher elevations during the middle Holocene. They were replaced with the current creosote scrub and desert riparian habitat at that time.

The Salton Trough, when not filled by Lake Cahuilla, probably contained much the same alkali sink habitat it now does throughout the Quaternary, although no paleoenvironmental data are available to directly confirm this.

Lake Cahuilla

As the Colorado River made its way toward the Gulf of California, it released its sediments onto a vast and growing delta. This gradual accumulation of sediments raised the overall height of the delta, particularly after large flood events. What followed during certain episodes was the diversion of the river's flow into the Salton Trough, resulting in the formation of a vast freshwater lake, variously referred to as Blake Sea, Lake LeConte, or Lake Cahuilla. The lake continued to rise until it reached the lip of the impounding delta, currently at 12 m above sea level, and the waters, less those lost to evaporation from the lake, could again flow south to the Gulf. The low-gradient, deltaic conditions at the lake's input channel were then poised to produce a new shift in the river's course, this time away from the lake and directly south toward the Gulf.

At least six Late Pleistocene infillings of Lake Cahuilla have left relic maximum shorelines at elevations between 52 and 31 m above sea level. The latest and lowest shoreline is tentatively radiocarbon dated at 26,000 B.P., but none of the Pleistocene stands are known to have cultural associations. Lake Cahuilla may have continued to form and then recede throughout the middle Holocene; archaeological remains are found in association with the lake as far back as 5000 B.P. (Schaefer 1994).

Late Holocene stands of Lake Cahuilla are somewhat better documented. The lake is known to have been present at times but not continuously during the millennium prior to A.D. 1000 (Love and Dahdul 2002; Waters 1983; Wilke 1978). Radiocarbon, stratigraphic, and historical evidence indicates that the lake underwent at least three cycles of filling and recession between ca. A.D. 1200 and 1700 (Laylander 1997). When present, the lake offered a range of resources, including freshwater fish, aquatic birds, freshwater mollusks, and shoreline plants. Its rises and falls, extending over decades and radically transforming the region's resource potential, created a uniquely unstable human environment.

CULTURAL SETTING

Prehistory

The following outline of Colorado Desert culture history largely follows a summary by Jerry Schaefer (2006). It is founded on the pioneering work of Malcolm J. Rogers in many parts of the Colorado and Sonoran deserts (Rogers 1939, 1945, 1966). Since then, several overviews and syntheses have been prepared, with each succeeding effort drawing on the previous studies and adding new data and interpretations (Crabtree 1981; Schaefer 1994; Schaefer and Laylander 2007; Wallace 1962; Warren 1984; Wilke 1976). Four successive periods, each with distinctive cultural patterns, may be defined for the prehistoric Colorado Desert, extending back in time over a period of at least 12,000 years. They include: Early Man (Malpais), Paleoindian (San Dieguito), Archaic (Pinto and Amargosa), and Late Prehistoric (Patayan).

Early Man Period (Malpais Pattern) (ca. 50,000 to 10,000 B.C.)

The Malpais Pattern is represented by archaeological materials that have been hypothesized to date between 50,000 and 10,000 B.C. (Begole 1973, 1976; Davis et al. 1980; Hayden 1976). The term was originally used by Rogers (1939, 1966) for ancient-looking cleared circles, tools, and rock alignments that he later classified as San Dieguito I. Malpais continued to be applied to heavily varnished choppers and scrapers found on desert pavements of the Colorado, Mojave, and Sonoran deserts that were thought to predate Paleoindian assemblages that included projectile points. Although few would question that most of the artifacts are culturally produced, dating methods remain extremely uncertain and have been assailed on numerous grounds (McGuire and Schiffer 1982:160-164). Arguments for early settlement of the Colorado Desert have been further eroded by the re-dating of the "Yuha Man." Originally dated to over 18,000 B.C. based on radiocarbon analysis of caliche deposits, more reliable dates based on the accelerator mass spectrometry (AMS) radiocarbon method applied to bone fragments now place the burial at about 3000 B.C. (Taylor et al. 1985).

Paleoindian Period (San Dieguito Pattern) (ca. 10,000 to 5000 B.C.)

Most of the aceramic lithic assemblages, rock features, and cleared circles in the Salton Basin were routinely assigned to the San Dieguito Phase III complex by many of the initial investigators. Rogers first distinguished the San Dieguito pattern in western San Diego County, based initially on surface surveys and subsequently refined through excavations at the C. W. Harris Site (Rogers 1929, 1939, 1966). His extensive surveys subsequently identified the pattern in the southern California deserts. Rogers proposed three phases of the San Dieguito complex in its Central Aspect, which encompassed the area of the Colorado and Mojave deserts and the western Great Basin. The successive phases were characterized by the addition of new, more sophisticated tool types to the pre-existing tool kit.

San Dieguito complex lithic technology was based on primary and secondary percussion flaking of cores and flakes. San Dieguito I and II tools include bifacial and unifacially reduced choppers and chopping tools, concave-edged scrapers (spokeshaves), bilaterally notched pebbles, and scraper planes. Appearing in the San Dieguito II phase are finely made blades, smaller bifacial points, and a larger variety of scraper and chopper types. The San Dieguito III tool kit is appreciably more diverse, with the introduction of fine pressure flaking; tools include pressure-flaked blades, leaf-shaped projectile points, scraper planes, plano-convex scrapers, crescentics, and elongated bifacial knives (Rogers 1939, 1958, 1966; Warren 1967; Warren and True 1961). Various attempts have also been made to seriate cleared circles into phases, but no convincing chronological scheme has yet emerged (Pendleton 1986).

Because of the surficial character of most desert sites and the scarcity of good chronological indicators, it has been difficult to test the validity of Rogers' San Dieguito I, II, and III phases as chronologically successive changes in the tool kit of a long-lived culture. Some of the variations may have developed contemporaneously in response to particular functional, ecological, or aesthetic requirements. Subsequent excavations at the C. W. Harris site in coastal San Diego County also failed to confirm Rogers' original observation of a stratigraphic separation between Phase II and Phase III assemblages (Warren 1967:171-172). Rogers (1966:39) also identified different settlement patterns characteristic of each phase, but as Vaughan (1982:6-11) argued, these distinctions were inadequately defined and inconsistently applied. The phase model may be tested and refined, but at present the application of phase distinctions does not appear to be warranted.

The San Dieguito pattern appears to reflect a hunter-gatherer adaptation consisting of small mobile bands exploiting small and large game and collecting seasonally available wild plants. An absence of milling stones has been seen as reflecting a lack of hard seeds and nuts in the diet, and as a diagnostic cultural trait distinguishing the San Dieguito pattern from subsequent Desert Archaic patterns (Moratto 1984; Rogers 1966; Warren 1967). Portable manos and metates are now being increasingly identified at coastal sites radiocarbon dated in excess of 6000 B.C. and in association with late San Dieguito assemblages. Arguments have also been made for the presence of a developed grinding tool assemblage during early periods, based on finds from the Trans-Pecos area of Texas (Ezell 1984). In regard to the Colorado Desert, Pendleton (1986:68-74) remarked that most ethnographically documented pounding equipment for processing hard seeds, wild mesquite, and screwbeans were made from wood and would not be preserved in the archaeological record.

Site distributions also suggest some of the basic elements of San Dieguito settlement patterns. Sites might be situated on any flat area, but the largest aggregations occurred on mesas and terraces overlooking major washes. Where lakes were present, sites are located around the edges. These were areas where a variety of plant and animal resources could be found and where water would have been at least seasonally available.

Archaic Period (Pinto and Amargosa Patterns) (ca. 5000 B.C. to A.D. 500)

The Pinto and Amargosa patterns were regional specializations within the general hunting and gathering adaptations that characterized the Archaic period. These patterns occur more frequently in the northern Great Basin, the Mojave Desert, and the Sonoran Desert east of the Colorado River. However, few Pinto or Amargosa (Elko series) projectile points have been identified on the desert pavements in the Colorado Desert, although that condition is beginning to change as the number of investigations increases. Some late Archaic sites are known, indicating occupations along the boundary between the low desert and Peninsular Range and at more favored habitats.

It has been suggested that the environment in the California deserts was unstable and inhospitable during this period, particularly during the so-called Altithermal period between 5000 and 2000 B.C., and that this condition forced mobile hunter-gatherers into more hospitable regions (Crabtree 1981; Schaefer 1994; Wilke 1976). The paleoenvironmental data discussed above do not have the resolution to detect such drastic conditions. Also, as mentioned, Lake Cahuilla may have mitigated Altithermal effects on human occupation in the Colorado Desert.

Several Archaic sites have been excavated in recent years. The most substantial Colorado Desert site dated to this period is Indian Hill Rockshelter in Anza-Borrego Desert State Park. At that site, 1.5 m of cultural deposits were excavated below a Late Prehistoric component (McDonald 1992). Particularly significant were 11 rock-lined cache pits and numerous hearths indicative of either a residential base or a temporary camp where food storage was integral to the settlement-subsistence strategy. Also recovered were numerous Elko Eared dart points, flaked lithic tools, and milling stone tools, as well as three inhumations, one of which was radiocarbon dated to 4070 \pm 100 B.P. Two rock-lined pits similar to those at Indian Hill Rockshelter, along with an accompanying late Archaic assemblage, were excavated at a small rockshelter in Tahquitz Canyon near Palm Springs (Bean et al. 1995). The small number of artifacts at the site suggested strategically stored food processing equipment that was used by a small, mobile group. Several important late Archaic sites recently have been documented from the northern Coachella Valley (Love and Dahdul 2002). Deeply buried midden deposits with clay-lined features and living surfaces, cremations, hearths, and a rockshelter deposit have been found at various sites in association with calibrated radiocarbon dates ranging from before 1000 B.C. to A.D. 700. Radiocarbon dates of almost 1000 B.C. and associated bird and fish bone confirm a Late Archaic period Lake Cahuilla occupational horizon, as well as Archaic period interlacustral phases. Larger habitation sites remained elusive in the Colorado Desert until 2006, when a series of deeply buried midden deposits and some house features were discovered under alluvial fan and dune formations at the very northern end of the Coachella Valley at Seven Palms near Desert Hot Springs (Mariam Dahdul, personal communication 2006). These findings bring Colorado Desert cultural history more in line with comparable late Archaic patterns in the Mojave Desert and Owens Valley.

Early projectile points in Imperial County have generally been reported only as isolates on desert pavements, but a recent inventory at the Salton Sea Test Base produced a cluster of early projectile points including Lake Mojave, Pinto/Gatecliff, and Elko forms, and even two eccentric crescents, scattered among protohistoric sites on the bed of Lake Cahuilla 30 m below sea level (Apple et al. 1997; Wahoff 1999). If these points are in situ, as the investigators suggest, presumably they escaped burial by lake sediments or were subsequently re-exposed. An alternative explanation may be that they were collected elsewhere and reused by protohistoric occupants. Several Archaic points have also been reported within the Truckhaven area. Direct evidence of an Archaic occupation comes from the Truckhaven flexed burial (IMP-109), found under a cairn and dated to 5790 \pm 250 B.P. (Taylor et al. 1985; Warren 1984:404).

The emerging picture of late Archaic occupation in the Salton Basin is of mobile hunter and gatherer bands with atlatls for hunting and milling stones for seed and nut processing, operating out of a limited number of base camps in optimal areas on the boundaries of the Salton Basin and on the shoreline of Lake Cahuilla.

2. Setting

This Archaic pattern may be viewed as a cultural precursor of the Late Prehistoric period, although linguistic data and tribal origin stories suggest some demographic displacements in the late prehistoric past.

Late Prehistoric Period (Patayan Pattern) (ca. A.D. 500 to 1700)

Sites dating to the Late Prehistoric period are probably more numerous than any other in the Colorado Desert. The period has been divided into four phases, including a pre-ceramic transitional phase from A.D. 500 to 800. The major innovations were the introduction of pottery production using the paddle-and-anvil technique around A.D. 800 and the introduction of floodplain agriculture on the Colorado River, perhaps at about the same time (Rogers 1945). Within the Colorado Desert, according to some investigators, ceramics first appear around A.D. 1000 (Love and Dahdul 2002). Exact dating for the presence of early domesticated plants is not available (Schroeder 1979). Both these technological advancements were presumably introduced either directly from Mexico or through the Hohokam culture of the Gila River (McGuire and Schiffer 1982; Rogers 1945; Schroeder 1975, 1979). The most recent Late Holocene episodes of Lake Cahuilla have been taken to define the Patayan II phase, bracketed by Patayan I and III phases and previously dated between about A.D. 1050 to 1500. However, recent research has demonstrated that a lake infilling occurred between A.D. 1600 and 1700 (Laylander 1997; Schaefer 1994). The now-confirmed presence of lake stands both before A.D. 1050 and after A.D. 1500 casts some doubt on the viability of the perceived Patayan phase distinctions.

Hargrave (1938) coined the term "Patayan" from the Walapai word for "old people" to refer to the late prehistoric archaeology of the Colorado River Valley. In so doing, he wanted to avoid assumptions that specific prehistoric cultures in this area were directly ancestral to the modern Yuman cultures. The Patayan pattern is equally applicable to the prehistoric ancestors of the desert Cahuilla, who speak an unrelated language but whose culture shares many of the economic and technological attributes of the cultures of the Yuman speakers.

Colton (1945:118) applied a direct historical approach to developing a Patayan culture scheme. Relying on very little information, for the most part no more than surface sherd scatters, he made an initial attempt at defining a Patayan pattern. Assuming that the ethnohistoric practice of intense warfare among Colorado River peoples extended back into the prehistoric past, he postulated that the center for the dispersion of Patayan peoples to the east and west lay on the Colorado River and was brought about by high population densities of warlike communities that were circumscribed by inhospitable desert conditions. The Ipai, Kumeyaay, and Tipai of California and the Havasupai, Walapai, and Yavapai of western Arizona were some of these offshoots. The presumption was that these people had spread into other areas by the same process of warfare that later drove the Kahwan, Halyikwamai, and Halchidhoma off the river to become ultimately amalgamated with the Maricopa on the Gila River. Colton also revised Kroeber's (1943) classification of river and delta Yuman languages to propose a southern branch (Laquish) centered on the Colorado Delta and a northern branch (Cerbat) centered on the Needles area. In another paper, Colton tentatively classified the Cohonina and Prescott patterns as branches of Patayan in the mountains of northwestern Arizona.

While Colton's cultural scheme focused on Arizona, Rogers established the first systematic culture history and artifact typologies for the Colorado Desert in California, but also including evidence from western Arizona. Rogers' (1936, 1945) investigations of Yuman ceramics and culture history remain fundamental for archaeological research in the region. He distinguished three phases of Late Prehistoric archaeology in the Colorado Desert as Yuman I, II, and III, with Yuman II being contemporary with the late Holocene phase of Lake Cahuilla between around A.D. 1000 and 1500. In applying the label "Yuman," Rogers brought back the assumed association between the archaeological pattern and a specific linguistic grouping.

Also included in this early period of basic archaeological research is Schroeder's examination of lower Colorado River sites (Schroeder 1952, 1979). Schroeder (1961) excavated the Willow Beach site, located

just below Boulder Canyon, one of the few stratified Late Prehistoric sites known on the Colorado River. He developed a cultural sequence that emphasized the similarities of the Colorado River assemblages with the upland areas of western and central Arizona, lumping a number of cultural patterns into the concept of the Hakataya pattern, an expanded version of Rogers' Yuman pattern (Schroeder 1979). Some scholars found Schroeder's concept of the Hakataya to be too inclusive and also noted conflicts with Rogers' original Yuman ceramic typology (see McGuire and Schiffer 1982). Schroeder (1957, 1958, 1975) also postulated associations between subdivisions of the Hakataya pattern, certain ceramic types, and historically identified tribal groups. These branch-ceramic-tribal associations include, among others, the linking of the Roosevelt branch, Tonto Brown pottery, and the Southeast Yavapai; the Cerbat branch, Cerbat Brown, and the Walapai; the La Paz branch, Needles Buff, and the Halchidhoma; the Palo Verde branch, Tumco Buff, and the Quechan; the Amacava branch, Parker Buff, and the Mojave; and the Salton branch, Topoc Buff, and the eastern Kumeyaay. This approach may give insufficient consideration to the mobility of some groups, who may have produced different ceramic types depending on the proximity of particular clay types to seasonal settlements.

The term "Patayan" regained prominence with the publication of Hohokam and Patayan by McGuire and Schiffer (1982). They provide a critical history of the development of the terminology and cultural concepts. Michael R. Waters (1982a, 1982b) applied the term to a preliminary ceramic chronology and typology for the Colorado Desert, based on Rogers' unpublished notes and type collection at the San Diego Museum of Man. Waters also critically discussed differences between Rogers' and Schroeder's approaches, both in the definition of prehistoric cultures and in the application of a Lower Colorado River Buff ceramic typology.

Within the Late Prehistoric period, between A.D. 1000 and 1700, desert peoples of this region developed wide-spectrum and diversified resource procurement systems emphasizing a collector organization using residential bases and temporary logistical camps, scheduled according to the ripening seasons of staple plant resources. Mobility was an important element in this pattern, with frequent travel between the Colorado River and Lake Cahuilla, when the lake was present.

The diversity of sites and assemblages associated with Lake Cahuilla indicate considerable variability in Late Prehistoric and protohistoric social and ecological adaptations to the lake (Wilke 1978). The number of house pits at fish camps ranges from one to more than a dozen, perhaps indicating the number of households in residence at any one time. Fish traps range from single examples to long lines that are suggestive of cooperative fishing ventures.

Archaeologically excavated house pits indicate that some have developed middens and diverse artifact types, suggestive of season-long temporary camps, while others have only sparse artifact associations suggestive of short-term fishing expeditions. Faunal assemblages vary from those largely limited to fish bone or the remains of migratory water birds, to others that contain more diverse resources, including rabbit and large mammal bone. This variability in site types and assemblage contents has yet to be correlated in a systematic manner with other variables, such as the recessional stages of Lake Cahuilla (reflected in elevation), localized geography and paleoenvironments, ethnicity, or other factors.

The numerous trail systems throughout the Colorado Desert attest to long-range travel to special resource collecting zones and ceremonial locales, trading expeditions, and possibly warfare. Pot drops, trailside shrines, and other evidence of transitory activities are associated with these trails (McCarthy 1993). Trade and travel is also seen in the distribution of localized resources such as Obsidian Butte obsidian, wonderstone from the south end of the Santa Rosa Mountains, soapstone, marine shell from the Gulf of California and the Pacific coast, and ceramic types. The Elmore site near Kane Springs, for example, contained evidence of Olivella shell bead manufacturing and other shell processing, trade, craft specialization, and possibly cultural connections with delta Yumans who may have been displaced during Lake Cahuilla infillings (Laylander 1997; Rosen 1995; Schaefer 2000).

Ethnography

Ethnography refers directly to cultural patterns that were observed during the historic period, primarily during the first half of the twentieth century, or to traditional culture as remembered during that period. However, used with proper caution, it also provides an invaluable source of analogies and inferences concerning earlier, prehistoric cultural patterns.

At the time of European contact, the project area was occupied by the Kamia (also known as Kumeyaay, Tipai, and Diegueño). The principal ethnographic source for the Kamia, or desert Kumeyaay, is E. W. Gifford (1918, 1931), but considerable additional information can be gleaned from A. L. Kroeber (1920, 1925) and C. Daryll Forde (1931), given the close association between the Kamia and Quechan, and from Leslie Spier (1923) and William D. Hohenthal (2001) with regard to the Kamia's Tipai/Kumeyaay affinities. Synthetic overviews and interpretations of merit have been prepared by Frederic N. Hicks (1963), James P. Barker (1976), Martha Knack (1981), and John C. Russell and his associates (2002).

The Kamia were directly related by language and culture to the western Ipai, Kumeyaay, and Tipai groups of the mountains and coastal areas of San Diego County and northern Baja California, and a little more remotely to the Cocopa and other Yumans in the Colorado River's delta. The Kamia occupied areas along the New and Alamo rivers, and at springs and walk-in wells in Imperial Valley. During the ethnohistoric period, they were politically and militarily associated with the Quechan-Mohave alliance in opposition to the Cocopa in the Colorado River delta and the Halchidhoma in the Palo Verde Valley portion of the lower Colorado River. They maintained particularly close relations with the Quechan at the confluence of the Colorado and Gila rivers and were permitted a farming rancheria at the large Quechan settlement of *Xuksil* (Quechan: "sandstone"), located a few km south of the modern Mexican town of Algodones and north of the course with the Alamo River near the southern tip of the Imperial Dunes (Russell et al. 2002:84). These people were collectively known as the *Kavely cadom* or "south dwellers" and were known to the early Spanish expeditions as the rancherías of San Pablo, whose leader was also named Captain Pablo. They were estimated to number 800 people when the Anza expedition passed through in 1774 (Bolton 1930:2:51; Forde 1931:101). The Sonora Franciscans established the mission of San Pedro y San Pablo de Bicuñer near this location in 1776, along with another mission at La Purísima Concepción, later to become Fort Yuma. Both were destroyed in a Quechan uprising on July 17, 1781, six months after their founding (Forbes 1965:191-204).

Two other Kamia encampments in Quechan territory were *Espayau* and *Michul*, located 13 km south of Pilot Knob near the modern town of San Luis in Sonora. Gifford's Kamia consultants did not recognize the names of four or five other settlements that are listed in Hodge (1907:330). The Kamia also used the Quechan occupation area of Cactus Lake (*E-ce-mon*), located 2-3 km southwest of the Cactus railroad stop, 1.6 km east of the dunes, and some 10 km north of the All-American Canal. This was an area where seasonal runoff from Pilot Knob Mesa would accumulate to form a large pan. The USGS maps show a zone of denser vegetation indicating shallow ground water. Quechan consultants identify this area as a cremation and burial ground (Russell et al. 2002:33, 84). A Kamia hunting and gathering territory (*Xakwinimis*) extended to the northern portion of the Imperial Sand Dunes and extending south past Highway 78 and across Pilot Knob Mesa to the Chocolate Mountains. This area figures in Kamia, Quechan, Kumeyaay, and Maricopa mythology (Russell et al. 2002:32, 84).

The Kamia maintained settlements at optimally watered locations on the New and Alamo rivers, planting crops after major overflows from the Colorado River into the Salton Trough. An 1849 census counted 254 Kamia people on the New River in Imperial Valley under Chief Fernando. They included 118 men, 82 women, and 54 children (Heintzelman 1857:53). By 1860, the County of San Diego Census recorded 105 Kamia people at New River (Indian Wells or *Xachupai*), distributed among 11 households or rancherías and led by a Captain Zacariah (San Diego Genealogical Society n.d.:120-122). This record is especially

valuable because it lists each household member by name, sex, and age. Presumably their numbers were much greater before the introduction of European diseases and probably dropped even more drastically with the rampant smallpox and measles epidemics of the 1860s. A series of prolonged droughts or floodwater failures in the nineteenth century also took their toll on the population and eventually drove most Kamia in Imperial Valley to live at the rancheria of *Xatopet*, possibly on an east-west portion of the Alamo River south of the Imperial Dunes near the village of Huerta, Baja California. This was an emergency planting place that the Quechan also used when the Colorado River failed to flood in the summer of 1851 (Kroeber 1980:190). The Kamia suffered additional casualties during conflicts with the Mexican military at Huerta and ultimately fled to live primarily with the Quechan.

The Kamia were organized into 10-11 non-localized exogamous patrilineages. Many Kumeyaay living to the west were also members of these same lineages, leading Gifford (1918, 1931:301) to conclude that the Kamia were, in essence, desert Kumeyaay who had assimilated many aspects of River Yuman culture. The identification of lineages with specific locations was probably more related to the settlement preferences of individual families that moved as lineage segments, rather than of any lineage territoriality. Gifford (1931:14) does suggest that some greater degree of lineage localization may have occurred in the past but was inhibited by mobility requirements of shifting arable lands. Spier's (1923) mountain Kumeyaay informants associated the clans of *Litc*, *tumau*, and *kwatL* with areas just south of the Salton Sea. As most of the totemic associations of the lineages are either to the Wildcat or the Coyote, the Kamia may have had some elements of a moiety system like that of the Cahuilla, although the Kamia were exogamous by lineage and not by totemic association. The economic unit was the extended family household consisting of a man and his wife (or wives), children, and grandparents. The 1860 census suggests households included additional adults. Probably as a result of River Yuman contact, the Kamia maintained a greater degree of "tribal" identification than their Kumeyaay kinsmen to the west, recognizing a tribal "chief" over all the lineages, an achieved rather than ascribed status functioning in the organization of economic activities, warfare, and diplomacy. It is not clear if this position may reflect a Euro-American effort to identify a responsible "captain."

Like their Yuman neighbors, the Kamia lived in rectangular, semi-subterranean structures of post-and-beam construction, with thatch and earthen roofs. They also built ramadas, lean-tos, and conical sweathouses. They dispersed their dwellings on or adjacent to arable alluvial terraces as close as possible to running water, hand-dug walk-in wells, or sloughs. There were no permanent villages, and their moves were conditioned by the availability of floodwater farming areas and the ripening of wild plants. The Kamia would move to higher terraces if flooding occurred. Seasonal overflow from the Colorado River that fed the New and Alamo river sloughs periodically failed, and the Kamia would move to other locations, including the Colorado River, during these stressful times.

The Kamia practiced a mixed economy of horticulture and hunting and gathering. Mesquite (*Prosopis glandulosa*) was the most important wild staple crop, as it was for other groups in the Colorado Desert. Seedpods were ready in July and were readily collected at *Espayau*, south of Pilot Knob, where the Kamia would make camp but where agriculture was not feasible. Acorns were either obtained directly in the Peninsular Range or through trade with the Kumeyaay in exchange for cultigens, especially watermelons. The Kamia also procured baked and dried agave cakes from the Kumeyaay but otherwise did not participate in the early spring agave harvest. Tule pollen and roots were gathered from sloughs, one favorite spot being Seven Wells on the east-west portion of the Alamo River south of the International Border. Gifford (1931:24) reports on another marsh plant called *wāró*. The seed capsules were pulled off by hand over a ceramic pot and the capsules were rubbed until the seeds were freed. The pods were then winnowed away with a ceramic dish. The seeds were ground on a metate and eaten dry. Either wooden mortars or stone metates were used for many wild seeds, followed by cooking. Gifford's (1931:27) consultants apparently had no knowledge of the widespread practice of parching seeds prior to grinding, although ceramic parching

2. Setting

trays occur at archaeological sites. Among the seeds exploited were saltbush (*Atriplex* sp.), yerba mansa (*Anemopsis californica*), and sedge (*Cyperus erythrorrhizos*).

The Imperial Dunes also provided several plant foods. These included the black stems of a short plant called *yidut*, which were boiled in a pot and then peeled (Gifford 1931:24). This was most likely the “sand food” (*Pholisma sonora*) that Castetter and Bell (1951:209) note the Cocopa called *oydt* and which they and the Quechan were observed collecting as late as 1895. The ball-shaped root of a plant called *nyus* was boiled and eaten. Although not mentioned by Gifford, it is very likely that sand food, discussed above, was also dug out of the sand dunes. In fact, Gifford’s list of exploited plants is very slim, and in all likelihood the Kamia gathered as diverse an array of plants as other Colorado River peoples and the Kumeyaay (Castetter and Bell 1951).

The Kamia fished for all the native species, applying the same methods as the River Yumans, except that they did not use the dip net. Also like other River Yumans, hunting was a minor activity, but prey included migratory waterfowl, squirrel, gopher, lagomorphs, deer, beaver, and bighorn sheep.

Clay for making ceramics was dug from Colorado River alluvial deposits (Gifford 1931:42). One of Clyde Wood’s Quechan consultants also identified the Imperial Dunes as an area to obtain clay (Russell et al. 2002:85).

The Kamia applied the same system of floodplain agriculture as the river and delta Yumans (Castetter and Bell 1951). Their fields extended along the lower alluvial terraces of the New and Alamo rivers, their locations shifting with each seasonal flood cycle. In a rare recording on the Township 12 North, Range 13 West U.S. General Land Office (GLO) Map from 1954-1956, a “Rancheria corn field” was documented on the west side of Section 36, about .4 km from the New River and about 10.5 km upstream from where the New River empties into the modern shore of the Salton Sea. Many other agricultural fields mostly likely also existed throughout the area although this was one of the few that was bisected by a surveyed section line and was thus mapped. Indian trails, ponds of fresh water and mesquite hummocks also dot the area, suggesting other attractions to the Kamia.

As previously mentioned, the Quechan also afforded the Kamia arable land on the Colorado River near Algodones. Irrigation after planting was not practiced, but they did build earthen dams at *Xatopet* (Kamia: “dam”) and elsewhere to channel water into higher terrace areas to saturate the soil before planting. The River Yumans also used brush weirs to divert floodwaters in order to soak specific terraces more thoroughly. The Kamia may have practiced actual irrigation agriculture in the Jacumba Valley, just south of the Mexican border near the crest of the Peninsular Range at the western extreme of Kamia occupation. Here several Kamia lineages shared the area with one Tipai lineage that did not venture into Imperial Valley. This is the only place that, at least during the early nineteenth century, sustained irrigation ditches from a spring were maintained to water crops, as contrasted with the soak-and-plant method of floodplain agriculture on the Colorado River and in Imperial Valley (Gifford 1931:22).

A 2-kg seed cache was found in a ceramic cooking pot in a dry cave at Jacumba that may shed some additional light on Kamia agriculture (Treganza 1947). It contained nine different species of seeds, each wrapped in a historic period twined bicolor textile. The seeds include native maize (*Zea mays*), tepary beans (*Phaseolus acutifolius*), butternut squash (*Cucurbita mochata*), pumpkin squash (*C. pepo*), and introduced watermelon (*Citrulus vulgaris*), muskmelon (*Cucumis melo*), sorghum (*Sorghum vulgare*), wheat (*Triticum compactum*), and barley (*Hordium vulgare*). (Adan Treganza previously discovered two other maize cob caches.) Even though the textile suggests a date after 1850, the cache has been frequently cited to support arguments for prehistoric agriculture west of the Colorado River (Bean and Lawton 1973; Forbes 1963). The seed complex matches that known for the early historic period O’odham (Pimans) who did practice irrigation agriculture like the prehistoric Hohokam who preceded them; it also matches the River Yumans

after Kino had introduced the European and Asian species in the late seventeenth century. The find may therefore suggest, as Treganza argued, that Kamia agricultural practices, including irrigation, derived from Native American sources rather than the missions. However, the introduced species and the associated textiles that Treganza dated to after 1850 without confirmation from a textiles expert (and which Jack Forbes [1963:7] only assumed to date from sometime after 1769) do not provide proof of prehistoric agriculture among the Kamia west of the Colorado River. Schaefer and Gary Huckleberry (1995) and Don Laylander (1995) provided additional rebuttals to the arguments for prehistoric agriculture west of the Colorado River. The question remains one of considerable interest for future archaeological investigations.

Lake Cahuilla (also referred to as Blake's Sea) figures notably in the Kamia's origin myth (Gifford 1931:75-83). Except among the Cahuilla, this represents the only other major recorded oral tradition regarding the prehistoric lake (Laylander 2004). The Kamia trace their origins to the north at *Wikami* (Mohave: *Avikwame*) near Needles, as do most River and Delta Yuman groups, as well as the southern Kumeyaay. The Mojave were said to have settled closest to *Avikwame*, and all the other groups migrated south to their respective territories. As related to Gifford (1931:79-80):

The Kamia came part way with the Yuma, then left them and went to the eastern shore of the Salton Sea. The sea (probably Blake's Sea) was large then and where El Centro is now there was sea. Later they moved to Indian Wells (Xachupai) and to Saxnuwai (near Holtville). There were ten men of each tribe. The ten Kamia men were the ancestors of ten lineages. Some of the Kamia passed through Imperial Valley into the mountains of San Diego County and became the Diegueño. There they had no seeds to plant, but found wild plant foods, deer, and mountain sheep.

The tribes of Mission Indians were also near the (presumably present) southern end of Salton Sea. They became afraid of the Kamia, hence the Cahuilla and other Shoshonean tribes fled north-westward.

Later there came from the mountain Wikami three persons who were to be the Kamia leaders. They were a hermaphrodite (described by the informant as half man, half woman) call Warharmi (cf. Mohave hwami) and her twin "sons" (not really her sons, Narpai said), both called Madkwahomai. These three had learned much at Wikami. They came south along the Colorado River. They found the feathers of birds which had died, as they traveled along day after day. The feathers were of the birds kak (crow), tokwil, and kusaul. The three travelers made headdresses of these feathers and painted their faces as for war. They brought bows, arrows, and clubs.

From the Colorado River at Yuma they crossed over to Imperial Valley. Their appearance so frightened the Kamia that they fled in all directions. One Kamia woman did not flee before the three. She was married by one of the Madkwahomai twins. Then the three newcomers and the woman settled at Saxnuwai.

The seeds of maize and beans had been given them by Mastamho. These the three travelers brought from Wikami and planted at Saxnuwai, thus introducing cultivation in the Imperial Valley. Those Diegueño who had gone to the mountains to live failed to receive the seeds. The three travelers brought the seeds of certain wild plants as well.

At Saxnuwai, Warharmi and the twins planted, for they found wet ground there. Before their departure from Wikami Mastamho had explained how everything was to be done. He had said that Warharmi and the two Madkwahomai were to be farmers and that they should go to dwell among the Kamia, whom Mastamho had sent to live on the shores of the Salton Sea.

2. Setting

Gifford considered the question of the phase of Lake Cahuilla to which the Kamia tradition may have been referring. He first weighed the argument that the final recession occurred before 1540 when Alarcón and Díaz sailed up the lower Colorado River. This was the prevailing view up until the 1980s. He then suggested that there certainly was enough time between Spanish *entradas* into the area for an additional infilling phase. A seventeenth-century infilling has now been substantiated archaeologically, as previously discussed above. Gifford indicated that the high degree of observed acculturation to Yuman culture does not provide a clear index to the length of time the Kamia had been in the Imperial and Colorado River valleys. The acculturation could have taken place even in the nineteenth century, after a late phase of Lake Cahuilla, he suggests. The occurrence of some western Kumeyaay lineages among the Kamia might also indicate movements into Imperial Valley by people escaping the missions or their influence. However, Gifford did not rule out the possibility that the Kamia population and cultural form may have been well established for a millennium (Gifford 1931:83, 86). In that case, many different prehistoric cultural trajectories could well have arisen from the multiple infillings and recessions of Lake Cahuilla during the late Holocene.

Trade relations were an important means of getting items not found within a tribal territory and of cementing social and political ties between different groups. Lying near the ethnohistoric boundaries between different linguistic groups, the project area may have been on or near a corridor for the exchange of goods and knowledge. The Kamia were very favorably positioned to trade with the Quechan because they enjoyed a close social relationship with them and they had access to the resources in the mountains of the Peninsular Range into which their territory extended. They were closely related to the other Kumeyaay groups of the mountains and coast and could act as trading middlemen with the Quechan. Both directly and indirectly, the Cahuilla of the Coachella Valley, the Paipai in Baja California, and the O'odham in Sonora may have also participated in this network. Chris White (1974) postulated that some of the alliance patterns were linked to east-west trade relationships, across which the greatest differential distribution of natural resources was present, as opposed to north-south relationships between groups that shared the same environmental zones.

Prior to the ethnohistoric period, trade dynamics may well have been quite different; archaeological data would be the primary source for reconstructing these earlier patterns. Ceramics may have themselves been trade items, or they may have served more often as containers for trade items. From the mountain Kumeyaay, the Kamia received wild tobacco, acorns, baked agave hearts, yucca fiber sandals, baskets, eagle feathers, and cordage carrying nets. In return the Kamia exported vegetal foods of the desert, probably mesquite cake foremost among them, and salt obtained from Imperial Valley. The Kamia also traded tobacco, an important ritual item, as well as receiving it from the Quechan. No doubt acorns and agave hearts, restricted to upper elevations, were Kumeyaay foods that would be in demand to the lowland Colorado River Yumans. The Colorado River Yumans, in return, exchanged cultigens such as dried pumpkin and corn, as well as gourds and seeds for rattles. The Cocopa, living near the Gulf of California, traded shell beads and pendants to the Kamia (Davis 1961).

Archaeological evidence indicates regular movement of obsidian for arrow points from Obsidian Butte at the southern end of the Salton Sea and soapstone arrow shaft straighteners from the Peninsular Range. Wonderstone for making flaked tools may also have had some trade value. It was obtained from the Rainbow Rock source at the southeast edge of the Santa Rosa Mountains and from Cerro Pinto, west of Mexicali and just south of the Mexican border. Not only utilitarian goods but esoteric objects, knowledge, and songs were also exchanged. Eagle feathers and even live eagles for the eagle-killing ceremony were much valued. The Cahuilla received gourd rattles and red pigment from the Colorado River Yumans. As another example of cultural exchange, very late in their history (ca. 1890), the Quechan incorporated the specific style of image from the Kamia into their *kar-úuk* (mourning) ceremony (Forde 1931:221).

History

Exploration and Initial Development

The project area has generally been marginal to major historic period events in the Colorado Desert (Lawton 1976). The wider region first came to the attention of Europeans in 1539-1540, when Francisco de Ulloa reached the northern limit of the Gulf of California, Hernando de Alarcón sailed up the lower Colorado River at least as far as present-day Yuma, and Melchior Díaz traveled overland from Sonora to reach and cross the river. The portions of the desert west of the Colorado River were first visited only as late as the 1770s, when Juan Bautista de Anza and Francisco Garcés pioneered a route from the Colorado River to coastal southern California, passing to the south and west of the study areas.

During the following decades, Spanish and Mexican forays into the Colorado Desert from coastal southern California and from northwestern Sonora continued, first in opening an overland route through Yuma and subsequently, after the Quechan revolt of 1781, in more limited probes to retaliate or to attempt to reopen the route. These explorations have been discussed in detail by Harry W. Lawton (1976). Most of the travel occurred well to the south of the study areas. However, in 1823-1826, José Romero led two expeditions that penetrated the Coachella Valley. With the Mexican-American War of 1846-1848, the Gold Rush in northern California, the development of the Butterfield Stage route, and explorations of potential railroad routes through the Colorado Desert, familiarity with the region steadily grew.

In 1853, Lieutenant K. S. Williamson of the U.S. Topographic Engineers and geologist William Blake surveyed the Salton Basin for railroad routes. In the process, Blake described the character of prehistoric Lake Cahuilla and recognized the fertility of the Salton Basin. Sporadic flooding occurred at least eight times from 1824 to 1904. Oliver Wozencraft lobbied the California legislature to gather support for the idea that the Salton Basin desert was irrigable. The state supported Wozencraft's idea and requested that Congress convey six million acres to Wozencraft. Although some members of the Public Lands Committee at least partially favored the idea, the U.S. Land Office was concerned about a huge land grant to one individual. Despite Wozencraft's continued lobbying efforts in Washington over the years, the transfer never occurred (Lafin 1995; Ní Ghabhláin and Schaefer 2005:7; Redlands Institute 2002a).

In the late 1800s, the federal government sponsored individual land development in the west in the form of a series of acts, including the Homestead (1862), Timber-Culture (1873), Desert Land (1877), and Timber and Stone (1878) acts (Robinson 1948:168-172). Most settlers in the desert depended on artesian wells in 1894, which made sustained irrigation efforts difficult. Hydraulic well drilling began in Indio in 1898 and offered another method of water collection for settlers (Nordland 1978:54; Redlands Institute 2002a).

Irrigation

The laterals and drains in the area are among the hundreds of similar features that make up the Imperial Irrigation District (IID) water distribution system. They provide water to irrigate low-lying areas of arable lands and also drain salt-laden run-off. The main IID canals, most notably the Eastside, Westside, and Central Main Canals, are primary components of the IID system, feeding water from the All-American Canal to all of the laterals. Water flow is controlled by means of checks and delivery gates throughout the IID system. From these laterals, farmers divert water to specific fields by several methods, including small irrigation ditches fed by siphon tubes, area flooding, pumps, and sprinkler systems. The main IID canals retain integrity of location, setting, feeling, and association more than any other elements within the IID and represent major engineering components on a scale comparable to the All-American Canal. How this irrigation system came into existence is a fascinating history and critical to understanding the recent history of the Imperial Valley.

2. Setting

Early Irrigation Systems In the Imperial Valley

As previously discussed, the possibility of diverting Colorado River water to irrigate the Imperial Valley was first raised in 1853 by William Blake, a geologist with an expeditionary unit charged with surveying the southern Colorado Desert for railroad routes. Blake's geological study observed that over thousands of years overflows of the Colorado River had drained into the Salton Trough through the New and Alamo rivers, forming ancient Lake Cahuilla. He also noted the apparent fertility of the alluvial soils of the Imperial Valley and suggested ways in which water might be brought from the Colorado River:

If a supply of water could be obtained for irrigation, it is probable that the greater part of the desert could be made to yield crops of almost any kind... By deepening the channel of New River, or cutting a canal so low that the water of the Colorado would enter at all seasons of the year, a constant supply could be furnished to the interior portion of the desert [Blake 1853:110].

Following Blake's report, several attempts were made to finance construction of a canal to bring water to the Imperial Valley. The first diversion canal and irrigation system was constructed by the California Development Company (CDC) under the direction of Charles Rockwood and George Chaffey (Dowd 1956:10ff; Frisby 1992:29; Starr 1990; Tout 1931). Construction on the Alamo or Imperial canal, as it was known, began in August 1900. An intake canal diverted water from the Colorado River south to Mexico from a point called Hanlon's Heading, adjacent to Pilot Knob just north of the U.S.-Mexico border. In Mexico, CDC made use of the Alamo overflow channel of the Colorado River to conduct the water a distance of approximately 40 miles. Minimal work was required to render the channel serviceable as a canal. Four miles east of Calexico another canal, the Central Main Canal, was constructed to transport the water north to the Imperial Valley. On May 14, 1901, the first diversion was made from the Colorado River to the new intake canal and the first delivery of water occurred in June 1901 (Dowd 1956:20). Cultivation of 1,500 acres began in the fall of that year. By the second year, 100,000 acres were irrigated in the Imperial Valley (JRP and Caltrans 2000).

Once water was available, settlement and cultivation of the valley was possible. George Chaffey had used a system of linking land and shares in a mutual water company in San Bernardino County to develop Ontario and Etiwanda, and the CDC employed the same method in the development of the Imperial Valley (JRP and Caltrans 2000:14, 17). Settlers could purchase up to 320 acres of government-owned land at \$1.25 an acre, but they also had to purchase \$7,900 worth of stock from Chaffey's Imperial Land Company, established by the CDC in one of the 13 mutual water companies in the valley. Frequently settlers were unable to come up with the cash required to buy the water stock and were forced to convey to the Imperial Land Company the mortgage on the land or the water stock as security on a 6 percent note on the cost of the water stock (Starr 1990:26).

The Central Main Canal was extended from the U.S. border to the northern boundary of Mutual Water Company No. 1 at Heading 4, a few miles to the southwest of the present city of Brawley. It began service in March 1902. From this point, water was supplied to Water Company No. 4 and to Water Company No. 8 through a branch canal and flume across the New River (Dowd 1956:20).

The Westside Main Canal, was originally constructed around 1901 to supply water from the Alamo Canal to Water Company No. 6 located north of the international border and west of the New River via the Encina Flume (Corey 1915:1576). It began at Sharp's Heading, traveled across the New River by flume and crossed the international boundary at a point approximately 10 miles west of Calexico. Additional canals included the East Side Main Canal, which supplied water to Water Company No. 7, and the Low Line or No. 5 Main

Canal, which served Water Company No. 5. By January 1, 1905, over 80 miles of main canals and over 700 miles of distribution canals had been constructed in the Imperial and Mexicali valleys (Dowd 1956:21).

There were few white settlers in the Imperial Valley prior to the construction of the Alamo Canal. In 1901, the only settlers were surveyors laying out the canals. With the completion of the main canals, settlement and cultivation of the valley followed rapidly. By 1902, the population had risen to 2,000. It had reached 7,000 by 1904, and just one year later it was between 12,000 and 14,000. The number of irrigated acres during the same time period grew from 1,500 in 1901 to 80,000 acres in 1905. By 1911, 220,000 acres were under cultivation (Dowd 1956:23).

By the turn of the twentieth century, the federal government was actively attempting to wrest control of public water resources out of the hands of private enterprises. The U.S. Reclamation Service (later the Bureau of Reclamation) was established in 1902 by the Reclamation Act with the objective of fostering the construction of irrigation projects, ensuring the equitable distribution of water resources, and thereby promoting the settlement of the western states. One of the first projects recommended by the Reclamation Service was the Yuma Project, which included the construction of a dam (Laguna Dam) at the Potholes site. It appears that one of the objectives of the Yuma Project was the diversion of water to the Imperial Valley in addition to the Yuma area (Pfaff et al. 1992).

In the Imperial Valley, the Reclamation Service began to challenge the right of the CDC to appropriate and profit from a publicly owned resource. The Colorado River, being a navigable waterway, was considered a public resource under Federal law and the appropriation of its water by the CDC was not recognized by the U.S. government without congressional approval and absent any valid state law (Dowd 1956:31). Under pressure from the Reclamation Service, CDC sought to secure the right from the Mexican government to divert water from the Colorado River in Mexico. This concession was granted in June 1904.

In the winter of 1902-1903, and again in 1904, there were water shortages caused primarily by silting of the intake canal. These problems, coupled with general dissatisfaction on the part of Imperial Valley farmers with CDC, led to growing support in the valley for federal control of the project. The Imperial Water Users Association, formed in 1904 by valley farmers to promote a Reclamation take-over of the project, negotiated the sale of the CDC and its properties to Reclamation for \$3 million. The Reclamation Service recommended against the purchase to the Secretary of the Interior, due in part to an adverse soil survey report filed by the U.S. Department of Agriculture in 1901 and 1903.

In an effort to overcome the problems with silting of the canal and channel and to prevent water shortages during the coming winter, CDC excavated a new channel without constructing a head gate to control the flow of water. As a result, winter flooding in 1905 caused the Colorado River to break its banks, overflowing through the New River and Alamo channels, flooding the Imperial Valley and creating the Salton Sea. Repeated attempts to stem the flow failed, and the river continued to flow into the valley over a period of two years. The CDC, already in financial difficulty prior to the canal break, was taken over by the Southern Pacific Company (SPC) in June 1905. Following personal intervention by President Roosevelt, and assurances by him that the costs of damming the channel would be reimbursed by the U.S. Government, SPC finally managed to close the break in February 1907 (Corey 1915).

As a result of the flooding, the western half of Imperial Valley was under water and approximately 13,000 acres of irrigable land was destroyed. By 1907, the Salton Sea was a lake 50 miles in length and 10 to 15 miles wide. An additional 30,000 acres, including 12,000 acres under cultivation, was left without a water supply, and all crops from this land were lost. The eastern part of the Valley was protected only by the banks of the Central Main Canal. The wooden flume that carried the West Side Main Canal across the New River was also destroyed.

Organization of Imperial Irrigation District

The CDC declared bankruptcy in 1909, as a result of litigation arising from the 1905 river break. In order to protect their interests, the people of the Imperial Valley voted in favor of establishing the Imperial Irrigation District (IID). The IID was organized for the purpose of acquiring the rights and properties of the CDC and its Mexican subsidiaries. When established, the IID included 513,368 acres and an additional 65,000 acres of water stock of the mutual water companies (Dowd 1956:53). At this time, claims and judgments against the CDC amounted to some \$3 million. In addition, funds would be needed to complete improvements and repairs to the canal and distribution system. In 1914, the IID voted a bond issue of \$3.5 million to purchase the CDC and its Mexican subsidiaries from the Southern Pacific Company and to undertake improvements to the canals and levees. Consequently the entire Westside Main Canal and Encina Flume were rebuilt and extended to serve the area to the west of New River, including the project area south of the Salton Sea (Dowd 1956:20, 40; Frisby 1992). In June 1916, the Southern Pacific Company deeded all of the properties of the CDC and its Mexican subsidiaries to the IID. Between November 1922 and March 1923, IID acquired each of the 13 mutual water companies for a total sum of over \$4.7 million.

Among the early projects that occurred in the vicinity of the project area under IID management was the closure of the Low Line (No. 5 Main) Canal, from which seepage was waterlogging arable lands at the southeastern end of the Salton Sea. In its place, irrigation laterals were constructed at half-mile intervals from the newly enlarged East Highline Canal. This work occurred between 1923 and 1927, which probably dates the Vail Laterals and Pumice Drain. It was also from 1922 on that the IID began efforts to channelize the outlets of both the New and Alamo rivers into the Salton Sea, cutting off bends and controlling bank erosion with new levees.

All-American Canal

The Fourth Annual Report of the U.S. Reclamation Service in 1904 included plans for an All-American Canal from Laguna Dam to Imperial Valley. This alignment required a 15.5-mile tunnel through the East Mesa Sand Hills, which would require an expenditure of \$20 million. The cost of the tunnel rendered this proposal financially infeasible. Following the 1905 river breach, President Roosevelt recommended that the U.S. acquire the properties of the CDC, construct an All-American Canal, and develop the Imperial Valley.

As soon as it was formed, IID began to examine alternatives to the existing Alamo Canal. Because of the legal uncertainties of diverting water from a foreign country and dealing with a foreign government, IID looked closely at the possibility of constructing an "all-American canal." In 1913, the District conducted a field survey for an all-American canal that would divert water from Laguna Dam and would parallel the international boundary to the East Highline Canal. In a report to IID Board of Directors in 1913, P. N. Nunn proposed that a realignment of the canal could shorten the length of the proposed tunnel through the Sand Hills to 8 miles, thereby reducing the cost. He also proposed that the construction of an open cut through the Sand Hills would cost a fraction of the cost of a tunnel. His estimate for the construction of the canal and two power plants was \$12 million. The following year IID began negotiations with the Secretary of the Interior with the objective of acquiring rights to diverting water from Laguna Dam. The Imperial Laguna Water Company, formed in 1914 to develop East Mesa lands, also proposed construction of a canal from Laguna Dam to East Mesa. By 1918, IID and the Imperial Laguna Water Company had agreed to cooperate in the construction of a canal to service both East Mesa and the remainder of the Imperial Valley.

In 1919, the All-American Canal Board submitted a survey and cost estimate to the Secretary of the Interior. This was followed by the Fall-Davis report, which recommended control of the Colorado River by a multiple-purpose reservoir project near Boulder Canyon, and the construction of a highline canal, together with a diversion dam and de-silting works, located entirely within the U.S. (Wilbur and Ely 1933). The Coachella Valley Water District (CVWD) was formed in 1918 to protect the interests of Coachella Valley

farmers. During deliberations on the Boulder Canyon Act, the CVWD lobbied vigorously for inclusion of the Coachella Canal in the project, to deliver water to the Coachella Valley. The Boulder Canyon Project Act was finally approved by an act of Congress on December 21, 1928, following seven years of deliberations (Wilbur and Ely 1933). It ratified the Colorado River Compact, and authorized the construction of Boulder Dam and the All-American and Coachella canals at a total estimated cost of \$165 million.

Detailed surveys for the All-American Canal route began in 1929 and were completed in 1930. As a result of these surveys, it was discovered that by constructing a diversion dam 5 miles north of Laguna Dam (Imperial Dam), an additional 22 ft. of elevation would be accrued, less excavation would be required at Pilot Knob, and an additional 26,000 acres could be irrigated in the Sand Hills. Furthermore, in spite of the cost of building the Imperial Dam, the upper route would result in a savings of \$2.5 million.

Construction of the All-American Canal began in 1934, following the construction of Boulder (Hoover) Dam. The construction of Imperial Dam and Desilting Works began in January 1936, and was completed in July 1938. The first irrigation water was delivered through the All-American Canal in 1940 (Bureau of Reclamation 1948). For a history of the construction of the All-American Canal, see Schaefer and O'Neill (2001). The Coachella Canal was constructed between 1938 and 1948 (Schaefer and Ní Ghabhláin 2003). It was at this time that the lands in the project area would have become arable.

At the time that the All-American Canal first started delivery of water to the Imperial Valley, on October 12, 1940, much of the land in the Imperial Valley (approximately 414,000 acres) was already under irrigation. By 1954, an additional 38,000 acres was brought into production. The real benefit of the All-American Canal water supply to the Imperial Valley was its dependability, allowing farmers to produce intensive high-risk crops with a higher per acre value. Unpredictable water flows prior to the completion to the All-American Canal had resulted in devastating crop losses. Unparalleled growth in agricultural production followed the completion of the All-American Canal in Imperial Valley.

Transportation

In the midst of this western settlement, the Southern Pacific Railroad built a line across the Salton Basin. Both Chinese and Native Americans were among those employed as laborers. The proposed route extended northwesterly through the Indian village of San Sebastian near San Felipe Creek, but the actual chosen route extended around the eastern boundary of the dry lakebed (Frey and Nell 1868; Rand McNally 1883). The first Southern Pacific trains operated in Indio in 1876, four years after choosing the spot as a halfway point between Los Angeles and Yuma. In 1877, rail lines continued southeast from Indio to Thermal, Walters (Mecca), Caleb, Durmid, Mortmar, Salton, Flowing Wells and Dos Palmas. The California and Arizona Express Company stage left the Dos Palmas station every other day, headed for Prescott and Phoenix (Nordland 1978:12, 103; Redlands Institute 2002a). As late as 1908, an abandoned section of the Southern Pacific Railroad extended in a southeasterly direction through the eastern portion of the Salton Sea. A connecting line extended southward at Imperial Junction through the Imperial Valley to Calexico, California (G. W. & C. B. Colton & Co. 1875; Rand McNally 1883; Redlands Institute 2002a:29).

Salt Industry

Salt mining in the Salton Sink was an important business opportunity. Depending on the sporadic inflow of Colorado River water, the natural resource existed as either a salt marsh or a bed of dry salt. Although Native Americans had used the salt, the New Liverpool Salt Company was the first to commercially extract the pure 6- to 12-in.-thick salt crust (Nordland 1978:58; Redlands Institute 2002b). New Liverpool Salt Company operations began in 1884 at the north end of the basin, where salt reserves covered over 1,000 acres. The Company transformed this resource into the production of 2,000 tons of salt each year. Workers plowed the land and created furrows 8 ft. wide by 6 in. deep, with each plowman harvesting 700 tons of pure salt each day, ten hours a day in extreme heat (Bailey and Aubry 1902:124; Laflin 1995. Piles of the

2. Setting

smashed salt were then sent by tram railway to the salt works in Salton for milling. At the salt works, Japanese and Cahuilla busily ground the salt and prepared the product for shipping to San Francisco (Lafin 1995). Salt produced by the Company supplied factories, dairies, druggists, and American consumers (Lafin 1995; Bailey and Aubry 1902:124; Redlands Institute 2002b). In 1902, houses and sheds surrounded the area that appeared to be a “crystal lake” because of all of the salt deposits.

At that time, salt seemed to be a never-ending resource. Neither the New Liverpool Salt Company nor the Standard Salt Company held land rights, so when President McKinley signed a bill that opened up the land, both companies raced to claim the best land. A collaborative effort between the two ultimately gave the companies several productive years, until the 1905 flood inundated the New Liverpool Salt Company (Lafin 1995).

Salt mining operations in the Salton Sink did not resume until 1919, when the Mullet Island Paint Company produced a small amount of salt from the hot springs. An independent operation of evaporative ponds existed from 1927 to 1930 near Mecca. In 1934, another salt works company, the Mullet Island Development Company, accumulated salt via salty wells. A joint venture between Seth and Chester Hartley in 1935 produced the Imperial Salt Company. It was the largest operation and existed on leased Imperial Irrigation District land, near Frink, until the Western Salt Company purchased the operation in 1942. From 1940 to 1942, the Mullet Island Salt Works of the Reeder Salt Company operated three evaporative ponds on land leased from the Imperial Irrigation District and produced salt for local icing and refrigeration cars. The Western Salt Company ceased operations in 1947 after producing 16,000 tons of salt from 175 acres of evaporative ponds (Redlands Institute 2002b).

Creation of the Salton Sea

The 1905 flood was simultaneously destructive and creative: it destroyed the irrigation system in the Imperial Valley and created the contemporary Salton Sea. The flooding occurred from the Alamo Canal and extended through the Imperial and Coachella valleys to fill a portion of the Salton Sink. This fascinating story begins with the development of the Imperial or Alamo Canal as an effort by the California Development Company (CDC), headed by Charles Rockwood and George Chaffey, to channel Colorado River water to Imperial Valley (Dowd 1956; MacDougal 1914; Rockwood 1909). They began operation in August 1900. The CDC's right to tap the Colorado River was jeopardized in 1903 when the river was declared a navigable waterway and therefore under federal control. These actions led to a period of conflict between the CDC and the Reclamation Service. The CDC pursued an alternate route outside the United States, since it would be impossible to obtain a water diversion permit from Reclamation. A new intake south of the U.S.-Mexican border was expected to solve the problem of the silted and ineffective Alamo Canal. Efforts to open this diversion without a permanent concrete headgate coincided in 1905 with an unusually rainy year, causing the Colorado River to redirect itself westward, forcing 360 million ft.³ of water per hour into the Imperial Valley (Ní Ghabhláin and Schaefer 2005:7-8; Starr 1990:36-37). The series of floods in the spring of 1905 forced the CDC to close the Mexican cut with a series of dams, but money ran out and limited engineering capabilities further burdened the situation. The Southern Pacific Railroad, which owned the CDC after June 1905, fought the disastrous floods during 1905-1907. Only monumental and extremely expensive efforts from the Southern Pacific Railroad finally diverted the Colorado River back to the Gulf of California (Ní Ghabhláin and Schaefer 2005:8; Starr 1990:36, 40). In the spring of 1907, the flooding caused the Southern Pacific to reroute 40 miles of the railroad track located within the Salton Sea from Mecca to Niland. Fill and rock protected the Salt Creek trestle and the water lapped at the railroad embankment at Mecca and other locations (Lafin 1995).

Since the 1905 flood, the depth and shape of the Salton Sea have changed. Several islands were created, including South Island (1907-1913), Rocky Hill (1907-1914), and Mullet Island. By 1915, the floodwaters of the Salton Sea receded and prompted the transformation of South Island and Rocky Hill into parts of the mainland (Redlands Institute 2002a:29). In 1943, surface water level was at 241 ft. below sea level. The

contemporary outlet from the New River did not extend into the Salton Sea within protective levees. Mullet Island had become incorporated into the mainland as a small peninsula. In August 1955, the surface water level was at 234.5 ft. below sea level (Blackburn 1936).

The incoming floodwaters that created the Salton Sea began as fresh water. However, the lower portion of the Salton Sink already contained significant levels of salt and the floodwaters crossed over saline agricultural fields in the Imperial Valley. A high ongoing rate of evaporation progressively concentrated the salts, and the Sea became increasingly saline. In the summer of 1914, the salt levels took a toll on the fish that had been carried in during the 1905 flood. Dead carp and bass washed ashore (Laflin 1995). The first saltwater fish introduced and successfully established in the Salton Sea was the orangemouth corvina, with shortfin corvina and gulf croaker introduced at a later stage. Establishing an ecological balance has been an inherent part of the challenge in maintaining the Salton Sea.

Over the years, the Salton Sea became a recreational hotspot in the desert. The lake in the desert attracted entrepreneurs such as Gus Eilers and John Goldthwaite, a bay area promoter. They acquired land from the Southern Pacific Railroad along the North Shore from the Mortmar train stop to the Sea in 1926. They planned Date Palm Beach, a development that started out small, trying to attract motorboat racers. In 1929, boat racers set five world records at the first boat races at Date Palm Beach. Hydroplane racing innovations took place on the Salton Sea in the late 1920s because the low elevation aided carburetion. Eilers survived the 1929 stock market crash and built his first set of guesthouses in 1932. He still catered to the motorboat enthusiasts, and Mrs. Eilers served the small community. She was sure to include Coachella Valley produce – grapefruits and dates – as part of her hospitality. In 1946, cinematographer C. Roy Hunter bought the resort and renamed it Desert Beach. Hunter founded the Desert Beach Yacht Club, but the rising Sea in 1948 stunted recreational growth. The additional waters from floods and agricultural runoff ultimately overtook the Desert Beach improvements (Laflin 1995; Redlands Institute 2002a).

The Desert Beach hosted the Salton Sea Speed Boat Regatta in 1949 and again in 1951. Helen's Beach House offered 1950s tourists and real estate speculators a lakeside retreat and relaxation. In 1955, the Salton Sea State Park was dedicated as the second largest California State Park. In the late 1950s, A. Penn Phillips founded Salton City, expecting the same success he achieved in developing the desert community of Hesperia. The first nine holes of a champion golf course opened in 1963, and the addition of a Salton Bay Yacht Club seemed to signify resurgence at the Salton Sea. Penn's desert community project sold numerous lots with few homes built on them. During 1950 to 1970, the recreational activities made the State Park the second most popular destination in California, but the popularity eventually faded due to the imbalances of the Sea (Laflin 1995; Redlands Institute 2002a).

One year after the establishment of the Salton Sea State Park, the Sea stood at 234.5 ft. below sea level. Although the Imperial Irrigation District made efforts to stabilize it, salinity levels increased in the 1980s. The Salton Sea Task Force grew out of the recognition that the quality of the water required action, and in 1993 that task force became the Salton Sea Authority. This newly established coalition combined the efforts of Riverside and Imperial counties, the Coachella Valley Water District, and the Imperial Irrigation District. Additionally, Congressman Sonny Bono formed a Congressional Salton Sea Task Force in 1997, and in 1998 the Salton Sea National Wildlife Refuge was renamed after the late congressman (Salton Sea Authority 1997).

3. METHODS AND RESULTS

RECORDS SEARCH

A record search of the CHRIS system was completed by the SCIC on January 28, 2019. The record search encompassed the Project area and a 0.5-mile radius around it. Eight previously conducted cultural resource studies have been documented within the 0.5-mile record search radius, none of which addressed the Project area directly (Table 1).

Table 1. Previous Cultural Resource Surveys within the 0.5-Mile Record Search Radius

SCIC File IM-	NADB No.	Authors	Year	Title	Relationship to APE
00271	1100271	WESTEC SERVICES, INC.	1982	SOUTH BRAWLEY PROSPECT GEOTHERMAL OVERLAY ZONE FINAL PROGRAM ENVIRONMENTAL IMPACT REPORT - VOLUME II	OUTSIDE
00286	1100286	WESTEC SERVICES, INC.	1983	SOUTH BRAWLEY PROSPECT GEOTHERMAL OVERLAY ZONE DRAFT PROGRAM ENVIRONMENTAL IMPACT REPORT VOLUME I	OUTSIDE
00295	1100295	WESTEC SERVICES, INC.	1983	FINAL SOUTH BRAWLEY PROSPECT GEOTHERMAL OVERLAY ZONE PROGRAM ENVIRONMENTAL IMPACT REPORT VOLUME I	OUTSIDE
01003	1101003	EDAW, INC.	2006	MASTER ENVIRONMENTAL IMPACT REPORT FOR THE MESQUITE LAKE SPECIFIC PLAN	OUTSIDE
01122	1101122	EDAW, INC.	2005	MASTER ENVIRONMENTAL IMPACT REPORT FOR THE MESQUITE LAKE SPECIFIC PLAN	OUTSIDE
01158	1101158	ARCHAEOLOGICAL CONSULTING SERVICES, LTD.	1996	AN ARCHAEOLOGICAL ASSESSMENT OF THE NILAND-IMPERIAL PIPELINE EXPANSION CORRIDOR, IMPERIAL COUNTY, CALIFORNIA	OUTSIDE
01204	1101204	VON WERLHOF, JAY	2007	IMPERIAL VALLEY BIOREFINEMENT, INC., A REPORT	OUTSIDE
01228	1101228	SWCA ENVIRONMENTAL CONSULTANTS	2006	VOLUME I - CULTURAL RESOURCES FINAL REPORT OF MONITORING AND FINDINGS FOR THE QWEST NETWORK CONSTRUCTION PROJECT, STATE OF CALIFORNIA	OUTSIDE

3. Methods and Results

One cultural resource has been previously recorded within the 0.5-mile record search radius (Table 2). The cultural resource, CA-IMP-008166, was recorded as being associated with the Niland to Calexico Railroad in 2003 by Collins and Pflaum as a standard gauge track on a gravel base. The Niland to Calexico Railroad, which was constructed between 1902 and 1904 by the Southern Pacific Company, runs 65 miles from Niland to Calexico and is still in use today. No historic addresses have been previously recorded within the Project area or record search radius. The SCIC record search documentation is included in Appendix A.

Table 2. Previously Recorded Cultural Resources within the 0.5-Mile Record Search Radius

Primary No. P-13-	Trinomial No. CA-IMP-	Record and Updates	Description	Proximity to APE
008682	008166	K. M. Collins 2003; A.C. Craft and M. J. Wise 2005; C. Ehringer 2011	AH7. Railroad Grade, AH11. Wall	Outside

The California Native American Heritage Commission (NAHC) was contacted on December 3, 2018 to conduct a record search of the Sacred Lands File (SLF) for the Project area. On January 11, 2019 the NAHC responded that the record search of the Sacred Lands File had returned positive results. "Positive results" indicates that there is specific site information in the SLF regarding issues of concern for Native Americans associated with the project area, and that there may be a potential for sacred sites, Tribal Cultural Resources and/or Traditional Cultural Properties in or in the vicinity of the Project area. The NAHC response specifically indicates that the Ewiiapaayp Tribe should be contacted for more information regarding the Project area. The NAHC response also includes a list of 19 other Native American individuals and organizations that should be contacted for further information regarding the project area, including the potential for sacred sites, Tribal Cultural Resources and/or Traditional Cultural Properties on or in the vicinity of the Project area. Documentation pertaining to the NAHC SLF search is included in Appendix B.

SURVEY

Methods

ASM Associate Archaeologist Doug Drake and Native Monitor Jonathon Jones of Campo Kumeyaay Nation completed the field survey on February 13, 2019. The Project area was systematically surveyed in 15-m intervals running east-west. The survey included the agricultural lands as well as the dirt roads and irrigation ditches running throughout the project area. Photographs, notes, and GPS points were taken within the project area. Overview photographs were also taken of the project area (Figures 4 and 5).

Field Conditions and Results

The survey area is within an alfalfa field where the ground surface visibility is 15-20% due to vegetation. Visibility in the western portion of the survey area (approximately 10 percent) was lower in relation to the eastern portion of the survey area (approximately 30 percent). Due to the dense vegetation coverage in western portion, the survey focused on the perimeter of the agricultural field, the proposed location for the well, and any areas that had high ground surface visibility (i.e. >25 percent). In the eastern side of the Project area, there were low-lying berms devoid of vegetation that were oriented east-west (Figure 5). The Project area was systematically surveyed and all visible ground surface areas were examined. No prehistoric or historic cultural resources were identified within the Project area during the archaeological survey.

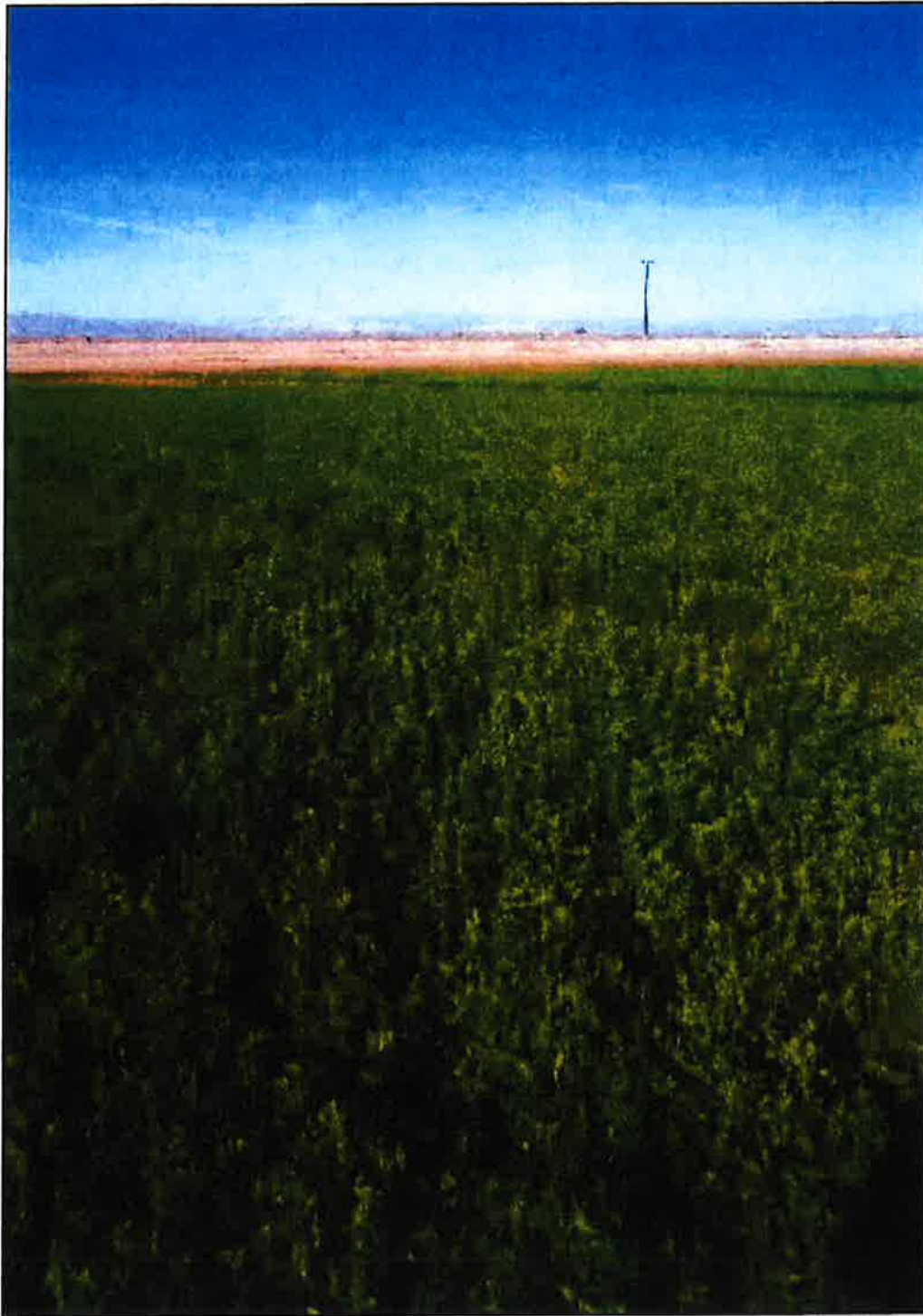

Figure 4. View of the north west corner of the Project area, facing north west.



Figure 5. View of the eastern side of the Project area, facing north west.

4. MANAGEMENT RECOMMENDATIONS

CEQA requires that all private and public activities not specifically exempted be evaluated against the potential for environmental damage, including effects to historical resources. Historical resources are recognized as part of the environment under CEQA. The act defines historical resources as “any object, building, structure, site, area, or place that is historically significant in the architectural, engineering, scientific, economic, agricultural, educational, social, political, military, or cultural annals of California” (Division I, Public Resources Code, Section 5021.1[b]).

Lead agencies have a responsibility to evaluate historical resources against the California Register of Historical Resources (CRHR) criteria prior to making a finding as to a proposed project’s impacts to historical resources. Mitigation of adverse impacts is required if the proposed project will cause substantial adverse change. Substantial adverse change includes demolition, destruction, relocation, or alteration such that the significance of a historical resource would be impaired. While demolition and destruction are fairly obvious significant impacts, it is more difficult to assess when change, alteration, or relocation crosses the threshold of substantial adverse change. The CEQA Guidelines provide that a project that demolishes or alters those physical characteristics of a historical resource that convey its historical significance (i.e., its character-defining features) is considered to materially impair the resource’s significance. The CRHR is used in the consideration of historical resources relative to significance for purposes of CEQA. The CRHR includes resources listed in, or formally determined eligible for listing in, the NRHP and some California State Landmarks and Points of Historical Interest. Properties of local significance that have been designated under a local preservation ordinance (local landmarks or landmark districts), or that have been identified in a local historical resources inventory, may be eligible for listing in the CRHR and are presumed to be significant resources for purposes of CEQA unless a preponderance of evidence indicates otherwise.

Generally, a resource shall be considered by the lead agency to be “historically significant” if the resource meets the criteria for listing on the CRHR (Pub. Res. Code SS5024.1, Title 14 CCR, Section 4852), which consist of the following:

- it is associated with events that have made a significant contribution to the broad patterns of local or regional history, or the cultural heritage of California or the United States; or
- it is associated with the lives of persons important to local, California, or national history; or
- it embodies the distinctive characteristics of a type, period, region, or method of construction, or represents the work of a master, or possesses high artistic values; or
- it has yielded, or has the potential to yield, information important to the prehistory or history of the local area, California, or the nation.

No prehistoric or historic cultural resources were identified within the proposed J.R. Simplot Project area either during the record searches or during the pedestrian survey. The Niland to Calexico railroad grade is located within 0.5-mile, but outside the proposed Project area, and will not be impacted by the proposed Project. Based on these findings, there will be no impact to historical resources associated with the development of the proposed J.R. Simplot Fertilizer Terminal Project. In accordance with CEQA, cultural resource management regulatory compliance activities are complete, and no further cultural resource management field work is recommended. The Ewiiapaayp Tribe should be contacted, along with the 19 other Native American individuals and organization listed by the NAHC for further information regarding the proposed project area including the potential for sacred sites, Tribal Cultural Resources and/or Traditional Cultural Properties in or in the vicinity of the Project area, in accordance with Senate Bill (SB) 52 requirements.

REFERENCES

- Apple, Rebecca McCorkle, Andrew York, Andrew Pignuolo, James H. Cleland, and Stephen Van Wormer
1997 *Archaeological Survey and Evaluation Program for the Salton Sea Test Base, Imperial County, California*. KEA Environmental, San Diego.
- Bailey, Gilbert E., and Lewis E. Aubry
1902 *The Saline Deposits of California*. California Division of Mines Bulletin No. 24. Sacramento.
- Barker, James P.
1976 Ethnographic Sketch of the Yuha Desert Region. In *Background to Prehistory of the Yuha Desert Region*, edited by Philip J. Wilke, pp. 21-41. Ballena Press Anthropological Papers No. 5. Ramona, California.
- Bean, Lowell John, and Harry W. Lawton
1973 Some Explanations for the Rise of Cultural Complexity in Native California with Comments on Proto-Agriculture and Agriculture. In *Patterns of Indian Burning in California: Ecology and Ethnohistory*, by Henry T. Lewis, pp. v-xvii. Ballena Press, Ramona, California.
- Bean, Lowell J., and Katherine Saubel
1972 *Temaipakh: Cahuilla Indian Knowledge and Usage of Plants*. Malki Museum Press, Banning, California.
- Bean, Lowell J., Jerry Schaefer, and Sylvia B. Vane
1995 *Archaeological, Ethnographic, and Ethnohistoric Investigations at Tahquitz Canyon, Palm Springs, California*. Cultural Systems Research, Menlo Park, California.
- Begole, Robert S.
1973 An Archaeological Survey in the Anza-Borrego Desert State Park: 1972. Preliminary Report. *Pacific Coast Archaeological Society Quarterly* 9(2):27-55.
1976 A Continuing Archaeological Survey in the Anza-Borrego Desert State Park: 1975-1976 Report. *Pacific Coast Archaeological Society Quarterly* 12(2):1-24.
- Blackburn, O. V.
1936 *Blackburn's Map of Imperial County*. O. V. Blackburn, Los Angeles.
- Blake, William P.
1853 Geological Report. In *Report of Explorations in California for Railroad Routes to Connect with the Routes Near the 35th and 32nd Parallels of North Latitude*, by R. S. Williamson. U.S. War Department, Washington, D.C.
- Bolton, Herbert Eugene
1930 *Anza's California Expeditions*. 4 vols. University of California Press, Berkeley.
- Bureau of Reclamation
1948 *Reclamation Project Data. A Book of Historical, Statistical and Technical Information on Reclamation Projects*. U.S. Government Printing Office, Washington, D.C.
- Castetter, Edward F., and William H. Bell
1951 *Yuman Indian Agriculture*. University of New Mexico Press, Albuquerque.

References

- Cole, Kenneth L.
1986 The Lower Colorado River Valley: A Pleistocene Desert. *Quaternary Research* 25:392-400.
- Colton, Harold S.
1945 The Patayan Problem in the Colorado River Valley. *Southwestern Journal of Anthropology* 1:114-121.
- Corey, H. T.
1915 *The Imperial Valley and the Salton Sink*. John J. Newbegin, San Francisco.
- Crabtree, Robert H.
1981 Archaeology. In *A Cultural Resources Overview of the Colorado Desert Planning Units* by Elizabeth von Till Warren, Robert H. Crabtree, Claude N. Warren, Martha Knack, and Richard McCarty, pp. 25-54. USDI Bureau of Land Management, California Desert District, Riverside.
- Davis, Emma Lou, Kathryn H. Brown, and Jacqueline Nichols
1980 *Evaluation of Early Human Activities and Remains in the Colorado Desert*. Great Basin Foundation, San Diego.
- Davis, James T.
1961 *Trade Routes and Economic Exchange among the Indians of California*. University of California Archaeological Survey Reports No. 54. Berkeley.
- Dowd, M. J.
1956 *History of the Imperial Irrigation District and the Development of Imperial Valley*. Imperial Irrigation District, Imperial, California.
- Ezell, Paul
1984 A New Look at the San Dieguito Culture. *San Diego State University Cultural Resource Management Casual Papers* 3(2):103-109.
- Forbes, Jack D.
1963 Indian Horticulture West and Northwest of the Colorado River. *Journal of the West* 11:1-14.
1965 *Warriors of the Colorado: The Yumas of the Quechan Nation and Their Neighbors*. University of Oklahoma Press, Norman.
- Forde, C. Daryll
1931 Ethnography of the Yuma Indians. *University of California Publications in American Archaeology and Ethnology* 28:83-278. Berkeley.
- Frey, A. C., and Louis Nell
1868 *Topographical Railroad and County Map of the States of California and Nevada*. A.C. Frey & Co, New York.
- Frisby, Karen J.
1992 *Imperial Valley: The Greening of a Desert*. Imperial Valley College Museum Society Occasional Paper No. 9, Ocotillo, California.
- Gifford, Edward W.
1918 Clans and Moieties in Southern California. *University of California Publications in American Archaeology and Ethnology* 14:155-219. Berkeley.

- 1931 *The Kamia of Imperial Valley*. Bureau of American Ethnology Bulletin No. 97. Washington, D.C.
- G. W. & C. B. Colton & Co.
1875 *Maps Showing the Southern Pacific Railroad and its Connections*. New York.
- Hargrave, Lyndon L.
1938 Results of a Study of the Cohonino Branch of the Patayan Culture in 1938. *Museum of Northern Arizona Museum Notes* 11(6):43-50.
- Hayden, Julian D.
1976 Pre-Altithermal Archaeology in the Sierra Pinacate, Sonora, Mexico. *American Antiquity* 41:274-289.
- Heintzelman, S. P.
1857 Report of Brevet Major S. P. Heintzelman, July 15, 1853. In *Indian Affairs of the Pacific*. House of Representatives Executive Document No. 76. (34th Congress, 3rd Session). U.S. Government Printing Office, Washington, D.C.
- Hicks, Frederic Noble
1963 Ecological Aspects of Aboriginal Culture in the Western Yuman Area. Unpublished Ph.D. dissertation, Department of Anthropology, University of California, Los Angeles.
- Hodge, F. W.
1907 *Handbook of American Indians North of Mexico*. Bureau of American Ethnology Bulletin No. 30. Washington, D.C.
- Hohenthal, William D., Jr.
2001 *Tipai Ethnographic Notes: A Baja California Indian Community at Mid-Century*. Ballena Press, Novato, California.
- Imperial County Planning and Development Services Department
2015 *Renewable Energy and Transmission Element, County of Imperial General Plan*. Electronic Document:<http://icpds.com/CMS/Media/Final-Renewable-Energy-and-Transmission-Element---10-6-15.pdf>. Site accessed October 10, 2016/
- Jaeger, Edmund C.
1965 *The California Deserts*. 4th ed. Stanford University Press, Palo Alto, California.
- Jennings, Charles W.
1967 Salton Sea Sheet. *Geologic Map of California*. California Division of Mines and Geology, Sacramento.
- Jones, Terry L., Gary M. Brown, L. Mark Raab, Janet L. McVickar, W. Geoffrey Spaulding, Douglas J. Kennett, Andrew York, and Phillip L. Walker
1999 Demographic Crises in Western North American during the Medieval Climatic Anomaly. *Current Anthropology* 40:137-170.
- JRP Consulting and California Department of Transportation (Caltrans)
2000 *Water Conveyance Systems in California. Historic Context Development and Evaluation Procedures*.

References

King, James E., and Thomas R. Van Devender

- 1977 Pollen Analysis of Fossil Packrat Middens from the Sonoran Desert. *Quaternary Research* 8:191-204.

Knack, Martha

- 1981 Ethnography. In *A Cultural Resources Overview of the Colorado Desert Planning Units*, by Elizabeth von Till Warren, Robert H. Crabtree, Claude N. Warren, Martha Knack, and Richard McCarty, pp. 55-82. Cultural Resources Publications, Anthropology-History, USDI Bureau of Land Management, California Desert District, Riverside.

Kroeber, Alfred L.

- 1920 Yuman Tribes of the Lower Colorado. *University of California Publications in American Archaeology and Ethnology* 16:475-485. Berkeley.
- 1925 *Handbook of the Indians of California*. Bureau of American Ethnology Bulletin No. 78. Washington, D.C.
- 1943 *Classification of the Yuman Languages*. University of California Publications in Linguistics 1:21-40.

Kroeber, Clifton B.

- 1980 Lower Colorado River Peoples: Hostilities and Hunger, 1850-1857. *Journal of California and Great Basin Anthropology* 2:187-190.

Laflin, Pat

- 1995 *The Salton Sea: California's Overlooked Treasure*. Coachella Valley Historical Society, Indio, California.

Lawton, Harry W.

- 1976 History and Ethnohistory of the Yuha Desert (1769-1865). In *Background to Prehistory of the Yuha Desert Region*, edited by Philip J. Wilke, pp. 43-72. Ballena Press Anthropological Papers No. 5. Ramona, California.

Laylander, Don

- 1995 The Question of Prehistoric Agriculture among the Western Yumans. *Estudios Fronterizos* 35-36:187-203.
- 1997 The Last Days of Lake Cahuilla: The Elmore Site. *Pacific Coast Archaeological Society Quarterly* 33(1-2):1-138.
- 2004 Remembering Lake Cahuilla. In *The Human Journey & Ancient Life in California's Deserts: Proceedings from the 2001 Millennium Conference*, edited by Mark W. Allen and Judyth Reed, pp. 167-171. Maturango Museum, Ridgecrest, California.

Love, Bruce, and Mariam Dahdul

- 2002 Desert Chronologies and the Archaic Period in the Coachella Valley. *Pacific Coast Archaeological Society Quarterly* 38(2-3):65-86.

MacDougal, D.T.

- 1914 *The Salton Sea: A Study of the Geography, the Geology, the Foristics, and the Ecology of a Desert Basin*. Carnegie Institution of Washington, Washington, D.C.

- McCarthy, Daniel F.
1993 Prehistoric Land-Use at McCoy Spring: An Arid-Land Oasis in Eastern Riverside County, California. Unpublished Master's thesis, Department of Anthropology, University of California, Riverside.
- McDonald, Alison Meg
1992 Indian Hill Rockshelter and Aboriginal Cultural Adaptation in Anza-Borrego Desert State Park, Southeastern California. Unpublished Ph.D. dissertation, Department of Anthropology, University of California, Riverside.
- McGuire, Randall H., and Michael B. Schiffer
1982 Problems in Culture History. In *Hohokam and Patayan*, edited by Randall H. McGuire and Michael B. Schiffer, pp. 153-222. Academic Press, New York.
- Moratto, Michael J.
1984 *California Archaeology*. Academic Press, Orlando, Florida.
- Morton, Paul K.
1977 *Geology and Mineral Resources of Imperial County, California*. County Report No. 7. California Division of Mines and Geology, Sacramento.
- Ní Ghabhláin, Sinéad, and Jerry Schaefer
2005 *Preserving a Record of the Old Coachella Canal: Documents Data Recover for the Coachella Canal Lining Project, Between Siphons 7 and 32, Imperial and Riverside Counties, California*. ASM Affiliates, Carlsbad, California.
- Nordland, Ole J.
1978 *Coachella Valley's Golden Years*. Desert Printing, Indio, California.
- Pendleton, Lorann
1986 *The Archaeology of the Picacho Basin, Southeast California*. Wirth Environmental Services, San Diego.
- Pfaff, Christine, Rolla L. Queen, and David Clark
1992 *The Historic Yuma Project: History, Resource Overview, and Assessment*. USDI Bureau of Reclamation Lower Colorado Region, Boulder City, Nevada.
- Rand, McNally & Co. (Rand McNally)
1883 *Map Exhibiting the Several Pacific Railroads Prepared for the Report on the Internal Commerce of the United States by the Bureau of Statistics*. Chicago.
- Redlands Institute
2002a *Salton Sea Atlas*. ESRI Press, Redlands, California.
2002b *Historic Salton Sea Salt Works*. University of Redlands. Electronic document, <http://www.institute.redlands.edu/salton/Downloads/Shapefiles/Metadata/ss_saltworks_metadata.htm>
- Robinson, William W.
1948 *Land in California: The Story of Mission Lands, Ranchos, Squatters, Mining Claims, Railroad Grants, Land Scrip, Homesteads*. University of California Press, Berkeley.

References

- Rockwood, Charles Robinson
1909 *Born of the Desert*. Calexico Chronicle, Calexico, California.
- Rogers, Malcolm J.
1929 The Stone Art of the San Dieguito Plateau. *American Anthropologist* 31:454-467.
1936 *Yuman Pottery Making*. San Diego Museum Papers No. 2.
1939 *Early Lithic Industries of the Lower Basin of the Colorado River and Adjacent Desert Areas*. San Diego Museum Papers No. 3.
1945 An Outline of Yuman Prehistory. *Southwestern Journal of Anthropology* 1:167-198. Albuquerque.
1958 San Dieguito Implements from the Terraces of the Rincon-Pantano and Rillito Drainage System. *The Kiva* 24:1-23.
1966 *Ancient Hunters of the Far West*. Union-Tribune Publishing, San Diego.
- Rosen, Martin D.
1995 IMP-6427, A Lake Cahuilla Shell Bead Manufacturing Site. *Proceedings of the Society for California Archaeology* 8:87-104.
- Russell, John C., Clyde M. Woods, and Jackson Underwood
2002 *An Assessment of the Imperial Sand Dunes as a Native American Cultural Landscape*. EDAW, San Diego.
- Salton Sea Authority
1997 *The Salton Sea: A Brief Description of its Current Conditions and Potential Remediation Projects*. Electronic document. <http://www.sci.sdsu.edu/salton/Salton_Sea_Description.html>
- San Diego Genealogical Society
n.d. *Census 1860, San Diego County*. Published typescript of original census. San Diego Genealogical Society, San Diego.
- Schaefer, Jerry
1994 The Challenge of Archaeological Research in the Colorado Desert: Recent Approaches and Discoveries. *Journal of California and Great Basin Anthropology* 16:60-80.
2000 Now Dead I Begin to Sing: A Protohistoric Clothes-Burning Ceremonial Feature in the Colorado Desert. *Journal of California and Great Basin Anthropology* 22:186-211.
- Schaefer, Jerry, and Collin O'Neill
2001 *The All-American Canal: An Historic Properties Inventory and Evaluation*. ASM Affiliates, Encinitas, California.
- Schaefer, Jerry, and Don Laylander
2007 The Colorado Desert: Ancient Adaptations to Wetlands and Wastelands. In *California Prehistory: Colonization, Culture, and Complexity*, edited by Terry L. Jones and Kathryn A. Klar, pp. 247-257. Altamira Press, Lanham, Maryland.
- Schaefer, Jerry, and Gary Huckleberry
1995 Evidence of Agriculture and Irrigation at Tahquitz Canyon. In *Archaeological, Ethnographic, and Ethnohistoric Investigations at Tahquitz Canyon, Palm Springs, California*, by Lowell John Bean, Jerry Schaefer, and Sylvia Brakke Vane, pp. XX.1-38. Cultural Systems Research, Menlo Park, California.

- Schaefer, Jerry, Shelby Gunderman, and Don Laylander
 2010 *Cultural Resource Study for the Hudson Ranch II Project, Imperial County, California*. ASM Affiliates, Carlsbad, California.
- Schaefer, Jerry, and Sinéad Ní Ghabhláin
 2003 *A History and Evaluation of the Coachella Canal, Riverside and Imperial Counties, California*. ASM Affiliates, Carlsbad, California.
- Schroeder, Albert H.
 1952 *A Brief Survey of the Lower Colorado River from Davis Dam to the International Border*. Manuscript on file, National Park Service, Boulder City.
 1957 The Hakataya Cultural Tradition. *American Antiquity* 23:176-178.
 1958 Lower Colorado River Buffware. In *Pottery Types of the Southwest*, edited by Harold S. Colton. Museum of Northern Arizona Ceramic Series 3D. Flagstaff.
 1961 *The Archaeological Excavations at Willow Beach, Arizona, 1950*. University of Utah Anthropological Papers No. 50. Salt Lake City.
 1975 *The Hohokam, Sinagua and the Hakataya*. Imperial Valley College Occasional Papers No. 3. El Centro, California.
 1979 Prehistory: Hakataya. In *Southwest*, edited by Alfonso Ortiz, pp. 100-107. Handbook of North American Indians, Vol. 9, William C. Sturtevant, general editor. Smithsonian Institution, Washington, D.C.
- Spier, Leslie
 1923 Southern Diegueño Customs. *University of California Publications in American Archaeology and Ethnology* 20:295-358. Berkeley.
- Starr, Kevin
 1990 *Material Dreams: Southern California through the 1920s*. Oxford University Press, New York.
- Taylor, R. E., L. A. Payen, C. A. Prior, P. J. Slota, Jr., R. Gillespie, J. A. J. Gowlett, R. E. M. Hedges, A. J. T. Jull, T. H. Zabel, D. J. Donahue, and R. Berger
 1985 Major Revisions in the Pleistocene Age Assignments for North American Human Skeletons by C-14 Accelerator Mass Spectrometry: None Older than 11,000 C-14 Years B.P. *American Antiquity* 50:136-140.
- Tout, Otis B.
 1931 *The First Thirty Years, Being an Account of the Principal Events in the History of Imperial Valley, Southern California, U.S.A.* Arts & Crafts Press, San Diego.
- Treganza, Adan E.
 1947 Possibilities of Aboriginal Agriculture among Southern Diegueño. *American Antiquity* 12:169-173.
- Van Devender, Thomas R.
 1990 Late Quaternary Vegetation and Climate of the Sonoran Desert, United States and Mexico. In *Packrat Middens: The Last 40,000 Years of Biotic Change*, edited by J. L. Betancourt, Thomas R. Van Devender, and Paul S. Martin, pp. 134-165. University of Arizona Press, Tucson.
- Van Devender, Thomas R., and W. Geoffrey Spaulding
 1979 Development of Vegetation and Climate in the Southwestern United States. *Science* 204:701-710.

References

- 1983 Development of Vegetation and Climate in the Southwestern United States. In *Origin and Evolution of Deserts*, edited by Stephen G. Wells and Donald R. Haragan, pp. 131-156. University of New Mexico Press, Albuquerque.
- Vaughan, Sheila J.
1982 A Replicative Systems Analysis of the San Dieguito Component at the C. W. Harris Site. Unpublished Master's thesis, Department of Anthropology, University of Nevada, Las Vegas.
- Wahoff, Tanya L.
1999 Flaked Lithic Tools from Recent Investigations on the Salton Sea Test Base. *Proceedings of the Society for California Archaeology* 12:20-27.
- Wallace, William J.
1962 Prehistoric Cultural Development in the Southern California Deserts. *American Antiquity* 28:172-180.
- Warren, Claude N.
1967 The San Dieguito Complex: A Review and Hypothesis. *American Antiquity* 32:168-185.
1984 The Desert Region. In *California Archaeology*, by Michael J. Moratto, pp. 339-430. Academic Press, Orlando, Florida.
- Warren, Claude N., and Delbert L. True
1961 The San Dieguito Complex and Its Place in California Prehistory. *University of California Archaeological Survey Annual Report 1960-1961:246-338*. Los Angeles.
- Waters, Michael R.
1982a Lowland Patayan Ceramic Tradition. In *Hohokam and Patayan: Prehistory of Southwestern Arizona*, edited by Randall H. McGuire and Michael B. Schiffer, pp. 275-297. Academic Press, New York.
1982b The Lowland Patayan Ceramic Typology. In *Hohokam and Patayan*, edited by Randall H. McGuire and Michael B. Schiffer, pp. 537-570. Academic Press, New York.
1983 Late Holocene Lacustrine Chronology and Archaeology of Ancient Lake Cahuilla, California. *Quaternary Research* 19:373-387.
- White, Chris
1974 Lower Colorado River Area. Aboriginal Warfare and Alliance Dynamics. In *'Antap: California Indian Political and Economic Organization*, edited by Lowell John Bean and Thomas F. King, pp. 111-136. Ballena Press Anthropological Papers No. 2. Ramona, California.
- Wilbur, Ray Lyman, and Northcutt Ely
1933 *The Hoover Dam Power and Water Contracts and Related Data*. U.S. Government Printing Office, Washington, D.C.
- Wilke, Philip J.
1976 *Background to Prehistory of the Yuha Desert*. Ballena Press Anthropological Papers No. 5. Ramona, California.
1978 *Late Prehistoric Human Ecology at Lake Cahuilla, Coachella Valley, California*. Contributions of the University of California Archaeological Research Facility No. 38. Berkeley.

APPENDICES

APPENDIX A
SCIC Documentation



South Coastal Information Center
 San Diego State University
 5500 Campanile Drive
 San Diego, CA 92182-5320
 Office: (619) 594-5882
 www.sclc.org
 nick@sclc.org

**CALIFORNIA HISTORICAL RESOURCES INFORMATION SYSTEM
 RECORDS SEARCH**

Company: ASM Affiliates
Company Representative: Mark Becker
Date Processed: 1/28/2019
Project Identification: Simplot Fertilizer Terminal 31370.00

Search Radius: 1/2 mile

Historical Resources: YES

Trinomial and Primary site maps have been reviewed. All sites within the project boundaries and the specified radius of the project area have been plotted. Copies of the site record forms have been included for all recorded sites.

Previous Survey Report Boundaries: YES

Project boundary maps have been reviewed. National Archaeological Database (NADB) citations for reports within the project boundaries and within the specified radius of the project area have been included.

Historic Addresses: YES

A map and database of historic properties (formerly Geofinder) has been included.

Historic Maps: YES

The historic maps on file at the South Coastal Information Center have been reviewed, and copies have been included.

Summary of SHRC Approved CHRIS IC Records Search Elements	
RSID:	2548
RUSH:	no
Hours:	1
Spatial Features:	9
Address-Mapped Shapes:	no
Digital Database Records:	0
Quads:	1
Aerial Photos:	0
PDFs:	Yes
PDF Pages:	37

This is not an invoice. Please pay from the monthly billing statement

EEC ORIGINAL PKG

APPENDIX B
NAHC Documentation

NATIVE AMERICAN HERITAGE COMMISSION
Cultural and Environmental Department
1550 Harbor Blvd., Suite 100
West Sacramento, CA 95691
Phone: (916) 373-3710
Email: nahc@nahc.ca.gov
Website: <http://www.nahc.ca.gov>
Twitter: @CA_NAHC



January 11, 2019

Douglas Drake
ASM

VIA Email to: ddrake@asmaffiliates.com

RE: J.R. Simplot Fertilizer Terminal Project, Imperial County

Dear Mr. Drake:

A record search of the Native American Heritage Commission (NAHC) Sacred Lands File (SLF) was completed for the information you have submitted for the above referenced project. The results were positive. Please contact the Ewiiapaayp Tribe on the attached list for more information. Other sources of cultural resources should also be contacted for information regarding known and recorded sites.

Attached is a list of Native American tribes who may also have knowledge of cultural resources in the project area. This list should provide a starting place in locating areas of potential adverse impact within the proposed project area. I suggest you contact all of those indicated; if they cannot supply information, they might recommend others with specific knowledge. By contacting all those listed, your organization will be better able to respond to claims of failure to consult with the appropriate tribe. If a response has not been received within two weeks of notification, the Commission requests that you follow-up with a telephone call or email to ensure that the project information has been received.

If you receive notification of change of addresses and phone numbers from tribes, please notify the NAHC. With your assistance, we can assure that our lists contain current information. If you have any questions or need additional information, please contact me at my email address: steven.quinn@nahc.ca.gov.

Sincerely,

A handwritten signature in cursive script that reads "Steven Quinn".

Steven Quinn
Associate Governmental Program Analyst

Attachment

**Native American Heritage Commission
Native American Contact List
Imperial County
1/11/2019**

Barona Group of the Capitan Grande

Edwin Romero, Chairperson
1095 Barona Road
Lakeside, CA, 92040
Phone: (619) 443 - 6612
Fax: (619) 443-0681
cloyd@barona-nsn.gov

Kumeyaay

Inaja-Cosmit Band of Indians

Rebecca Osuna, Chairperson
2005 S. Escondido Blvd.
Escondido, CA, 92025
Phone: (760) 737 - 7628
Fax: (760) 747-8588

Kumeyaay

Campo Band of Mission Indians

Ralph Goff, Chairperson
36190 Church Road, Suite 1
Campo, CA, 91906
Phone: (619) 478 - 9046
Fax: (619) 478-5818
rgoff@campo-nsn.gov

Kumeyaay

Jamul Indian Village

Erica Pinto, Chairperson
P.O. Box 612
Jamul, CA, 91935
Phone: (619) 669 - 4785
Fax: (619) 669-4817
epinto@jiv-nsn.gov

Kumeyaay

Ewiiapaayp Tribe

Michael Garcia, Vice Chairperson
4054 Willows Road
Alpine, CA, 91901
Phone: (619) 445 - 6315
Fax: (619) 445-9126
michaalg@leaningrock.net

Kumeyaay

Kwaaymii Laguna Band of Mission Indians

Carmen Lucas,
P.O. Box 775
Pine Valley, CA, 91962
Phone: (619) 709 - 4207

Kumeyaay

Ewiiapaayp Tribe

Robert Pinto, Chairperson
4054 Willows Road
Alpine, CA, 91901
Phone: (619) 445 - 6315
Fax: (619) 445-9126
wmicklin@leaningrock.net

Kumeyaay

La Posta Band of Diegueno Mission Indians

Javaughn Miller, Tribal Administrator
8 Crestwood Road
Boulevard, CA, 91905
Phone: (619) 478 - 2113
Fax: (619) 478-2125
jmiller@LPtribe.net

Kumeyaay

lipay Nation of Santa Ysabel

Virgil Perez, Chairperson
P.O. Box 130
Santa Ysabel, CA, 92070
Phone: (760) 765 - 0845
Fax: (760) 765-0320

Kumeyaay

La Posta Band of Diegueno Mission Indians

Gwendolyn Parada, Chairperson
8 Crestwood Road
Boulevard, CA, 91905
Phone: (619) 478 - 2113
Fax: (619) 478-2125
LP13boots@aol.com

Kumeyaay

lipay Nation of Santa Ysabel

Clint Linton, Director of Cultural Resources
P.O. Box 507
Santa Ysabel, CA, 92070
Phone: (760) 803 - 5694
cjlinton73@aol.com

Kumeyaay

Manzanita Band of Kumeyaay Nation

Angela Elliott Santos, Chairperson
P.O. Box 1302
Boulevard, CA, 91905
Phone: (619) 766 - 4930
Fax: (619) 766-4957

Kumeyaay

This list is current only as of the date of this document. Distribution of this list does not relieve any person of statutory responsibility as defined in Section 7050.5 of the Health and Safety Code, Section 5097.94 of the Public Resource Section 5097.98 of the Public Resources Code.

This list is only applicable for contacting local Native Americans with regard to cultural resources assessment for the proposed J.R. Simplot Fertilizer Terminal Project, Imperial County.

**Native American Heritage Commission
Native American Contact List
Imperial County
1/11/2019**

**Mesa Grande Band of Diegueno
Mission Indians**

Virgil Oyos, Chairperson
P.O. Box 270
Santa Ysabel, CA, 92070
Phone: (760) 782 - 3818
Fax: (760) 782-9092
mesagrandeband@msn.com
Kumeyaay

**Sycuan Band of the Kumeyaay
Nation**

Lisa Haws, Cultural Resources
Manager
1 Kwaaypaay Court
El Cajon, CA, 92019
Phone: (619) 312 - 1935
lhaws@sycuan-nsn.gov
Kumeyaay

**Mesa Grande Band of Diegueno
Mission Indians**

Mario Morales, Cultural
Resources Representative
PMB 366 35008 Pala Temecula
Rd.
Pala, CA, 92059
Phone: (760) 622 - 1336
Kumeyaay

**Viejas Band of Kumeyaay
Indians**

Julie Hagen,
1 Viejas Grade Road
Alpine, CA, 91901
Phone: (619) 445 - 3810
Fax: (619) 445-5337
jhagen@viejas-nsn.gov
Kumeyaay

**San Pasqual Band of Diegueno
Mission Indians**

John Flores, Environmental
Coordinator
P. O. Box 365
Valley Center, CA, 92082
Phone: (760) 749 - 3200
Fax: (760) 749-3876
johnf@sanpasqualtribe.org
Kumeyaay

**Viejas Band of Kumeyaay
Indians**

Robert Welch, Chairperson
1 Viejas Grade Road
Alpine, CA, 91901
Phone: (619) 445 - 3810
Fax: (619) 445-5337
jhagen@viejas-nsn.gov
Kumeyaay

**San Pasqual Band of Diegueno
Mission Indians**

Allen Lawson, Chairperson
P.O. Box 365
Valley Center, CA, 92082
Phone: (760) 749 - 3200
Fax: (760) 749-3876
allenl@sanpasqualtribe.org
Kumeyaay

**Sycuan Band of the Kumeyaay
Nation**

Cody J. Martinez, Chairperson
1 Kwaaypaay Court
El Cajon, CA, 92019
Phone: (619) 445 - 2613
Fax: (619) 445-1927
ssilva@sycuan-nsn.gov
Kumeyaay

This list is current only as of the date of this document. Distribution of this list does not relieve any person of statutory responsibility as defined in Section 7050.6 of the Health and Safety Code, Section 5097.84 of the Public Resource Section 5097.98 of the Public Resources Code.

This list is only applicable for contacting local Native Americans with regard to cultural resources assessment for the proposed J.R. Simplot Fertilizer Terminal Project, Imperial County.