



BOARD AGENDA FACT SHEET

CLERK USE ONLY
BOS ACTION

Planning & Development Services
Department

October 24, 2023
Requested Board Date

1. Request:

Board Approval

XX

Information
Only/Presentation
Scheduled Hearing
Time: _____

11:00 a.m.

Other (specify)

2. Requested Action: *Type requested action below*

The Imperial County Planning & Development Services Department respectfully requests the Board of Supervisors conduct a public hearing to consider the following actions as recommended by the Planning Commission regarding the VEGA SES 4 SOLAR ENERGY STORAGE Project:

- A. Adopt Resolution for the approval of the Water Supply Assessment, with Findings; and,
- B. Adopt Resolution for the Certification of the Final Environmental Impact Report, ERRATA, (SCH #2021050018), with CEQA Findings; and,
- C. Adopt Resolution for the approval of the Mitigation Monitoring and Reporting Program (MM&RP); and,
- D. Adopt Resolution for the approval of Conditional Use Permit #20-0020, with Conditions of Approval.

3. Cost \$ 0

Source: N/A

4. If approval of Contract, reviewed/approved by County Counsel on: NO

By: _____ Action Request # N/A
Assigned by County Counsel's Office

5. If approval of position allocation change, reviewed by Human Resources on: N/A

By: N/A

6. Electronic copy submittal date: 10/05/23 By: Rosa A. Soto, Office Supervisor



Department Head/Agency Representative

INSTRUCTIONS: Back-up must be submitted **15 BUSINESS days prior** to requested date (Please note a Holiday counts as a Business day.) Back-up submitted must contain an **Original and 2 copies**. Copies must be submitted to the County Executive Office double sided and three (3) hole punched. Back-up must be submitted in a PDF format to vanessasalcido@co.imperial.ca.us and gracielaalvarez@co.imperial.ca.us

Reviewed By: _____
Deputy CEO

Reviewed By: _____
Deputy CEO

CEO/CLERK USE ONLY:

DATE STAMP

BOARD DATE: _____

Action _____ Filing _____

Consent _____ Presentation _____

Hearing _____ CEO Approval _____

Other (specify) _____

CEO

Date



Imperial County Planning & Development Services Planning / Building

Jim Minnick
DIRECTOR

TO: Board of Supervisors.

October 5, 2023

FROM: Jim Minnick, Director of Planning & Development Services

M/O _____

SUBJECT: VEGA SES 4 SOLAR ENERGY STORAGE Project – Water Supply Assessment (WSA), Final Environmental Impact Report (FEIR), Mitigation Monitoring and Reporting Program (MM&RP) and Conditional Use Permit (CUP) #20-0020

Dear Board Members:

REQUESTED ACTION:

The Imperial County Planning & Development Services Department respectfully requests the Board of Supervisors conduct a public hearing to consider the following actions as recommended by the Planning Commission regarding the VEGA SES 4 SOLAR ENERGY Storage Project:

- A. Adopt Resolution for the approval of the Water Supply Assessment, with Findings; and,
- B. Adopt Resolution for the Certification of the Final Environmental Impact Report (SCH# 2021050018), Errata with CEQA Findings; and,
- C. Adopt Resolution for the approval of the Mitigation Monitoring and Reporting Program (MM&RP); and,
- D. Adopt Resolution for the approval of Conditional Use Permit #20-0020, with Conditions of Approval.

BACKGROUND:

The applicant is proposing to develop a 100-megawatt (MW) solar photovoltaic (PV) energy generation project with an integrated battery storage system not to exceed 200 MW. The project includes a solar energy generation facility, a battery storage system, a switching station and a gen-tie line. The ultimate energy output is dependent on several variables, including off-take arrangements and the evolving efficiency of PV panels.

The proposed project includes a Water Supply Assessment, a request for Lot Tie Agreement, a Conditional Use Permit application, and a comprehensive environmental review in the form of an Environmental Impact Report.

Imperial County is the "lead agency" for this Project. Lead agency is defined as, "the public agency, which has the principal responsibility for carrying out or approving a project." The County must undertake the following discretionary actions and approvals for the Project:

- WATER SUPPLY ASSESSMENT

This WSA study was prepared pursuant to Senate Bill 610, which requires a lead agency to identify any public water system that may supply water to the project. IID reviewed the WSA and found it to be acceptable for incorporation into the Final EIR. The County Planning Department has incorporated the new template as required by IID.

- CERTIFICATION OF THE FINAL EIR

The County has responded to written comments as part of the Final EIR to be considered for certification by the Board of Supervisors prior to deciding on the Project. An Errata was written to address updates on plan.

- MITIGATION MONITORING AND REPORTING PROGRAM

A Mitigation Monitoring and Reporting Program (MMRP) once approved this plan will be adopted as required by CEQA Guidelines Section 15097 to ensure that mitigation measures identified in the EIR are implemented as appropriate.

- CONDITIONAL USE PERMIT

The proposed project CUP #20-0020 for solar energy generation and battery storage will require approval by the Board of Supervisors before construction. The project is on lands zoned A-3 RE per Title 9, Division 5: Zoning Areas Established, Chapter 9, Sections 90509.02 and 90520.02. Additionally, the energy storage component would be removed at the time of associated solar facility removal.

Environmental Analysis:

Due to the potential for significant impacts resulting from the proposed VEGA SES 4 Energy & Storage Project, the County determined that an EIR would be necessary. The County prepared an Initial Study (Code of California Regulations [CCR] §15063b (1)(A)) and subsequently issued a Notice of Preparation (NOP) for the preparation of an EIR (SCH. No. 2021050018). The NOP was distributed to city, county, state and federal agencies, other public agencies, and various interested private organizations and individuals to define the scope of the EIR. The NOP was also published in the Imperial Valley Press. The purpose of the NOP was to identify public agencies and public concerns regarding the potential impacts of the proposed Project, and the scope and content of environmental issues to be addressed in the EIR. Circulation of the NOP started May 4, 2021, and ended June 7, 2021. A public scoping meeting was held on May 13, 2021, at the Board of Supervisors meeting room to gather input from the public.

Final Environmental Impact Report SCH #2021050018

On November 22, 2022, a Notice of Completion (NOC) was filed with the State Clearinghouse for the Draft EIR, initiating the 50-day public review period of the Draft EIR document, and associated technical appendices. Concurrent with filing the NOC, the County is also required to provide notice to the public, agencies, organization, and other interested parties of the availability of the Draft EIR for review and comment. A Notice of Availability (NOA) was published on November 22, 2022, in the Imperial Valley Press newspaper. The public review and comment period ended January 10, 2023. Responses to DEIR comments received are part of the FEIR & Errata package.

MITIGATION MONITORING AND REPORTING PROGRAM

The County must adopt a Mitigation Monitoring and Reporting Program (MMRP) for mitigation measures that have been incorporated into or imposed upon the project to reduce or avoid significant effects on the environment (CCR §15097). This program will be designed to ensure that these measures are carried out during project construction and operation.

The specific reporting or monitoring program required by CEQA is not required to be included in the EIR. However, any mitigation measures adopted by the County as part of the certified Final EIR will be considered as conditions of approval for the project and will be included in the MMRP to ensure and verify compliance.

Airport Land Use Commission

The Imperial County Airport Land Use Commission on August 18, 2021, held a public meeting to review the VEGA SES 4 SOLAR ENERGY& STORAGE Project. The Project was deemed compatible with the 1996 Imperial County Airport Land Use Compatibility Plan (ALUCP).

SUMMARY:

The Planning staff is available to answer any questions you may have.

Thank you.

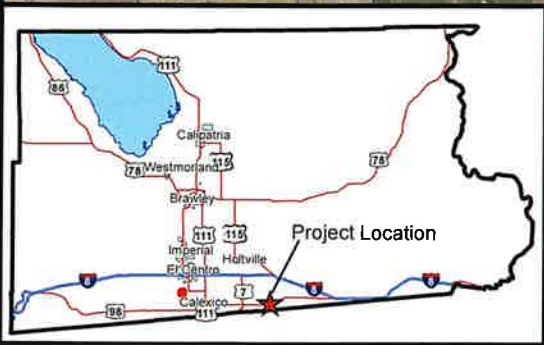
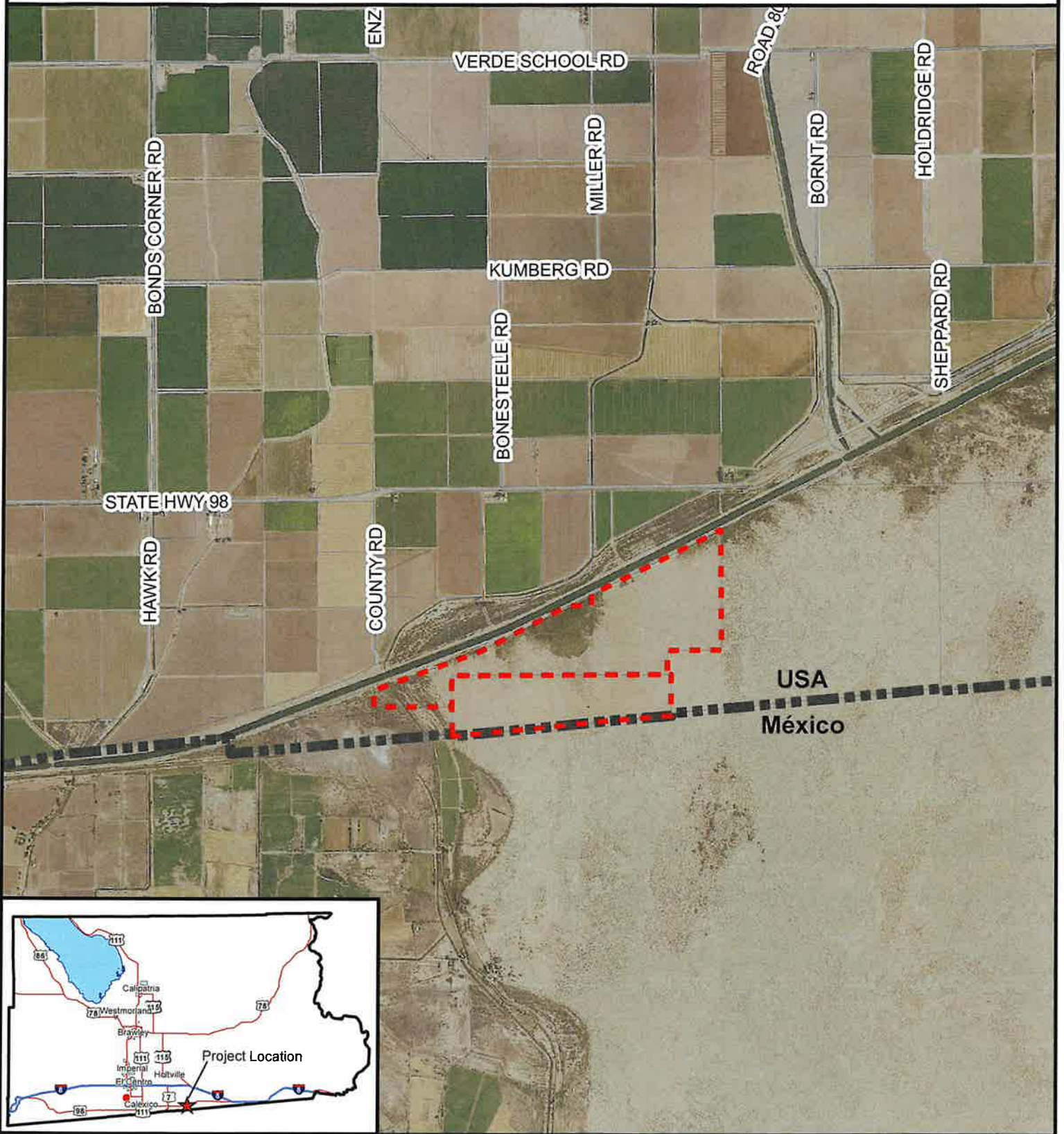
Attachment A.	Project Location Map
Attachment B.	Water Supply Agreement Resolution
Attachment C.	Final Environmental Impact Report & CEQA Findings Resolution
Attachment D.	Mitigation Monitoring and Reporting Program Resolution
Attachment E.	Conditional Use Permits CUP 20-0020 w/Resolution
Attachment F.	PC Original Package on a CD

cc: Miguel Figueroa, County Executive Officer
Eric Havens, County Counsel
Jim Minnick, Director Planning and Development Services
Michael Abraham, AICP, ICPDS Assistant Director
Files: 10.110; 40.103; 40.110; 40.111

MA\db\rs\I:\AllUsers\APN\059\300\015\CUP20-0020\BS FOLDER\update board package 10 24 23\CUP20-0020 BOARD REQ LTR 10 24 23.docx

**Attachment A:
Location Map**

PROJECT LOCATION MAP



**APEX ENERGY SOLUTIONS LLC,
(VEGA4)
CUP #20-0020
APN 059-300-015 AND 059-300-017-000**

	Project Location
	International Boundary
	Parcels
	Centerline



Attachment B:
WSA

RESOLUTION NO.

A RESOLUTION OF THE BOARD OF SUPERVISORS OF THE COUNTY OF IMPERIAL, CALIFORNIA, FOR THE APPROVAL OF THE WATER SUPPLY ASSESSEMENT (WSA) ON THE VEGA SES 4 SOLAR ENERGY STORAGE PROJECT.

WHEREAS, the VEGA SES 4 Solar Energy Project qualifies as a “project” under the Water Code triggering the need to prepare a Water Supply Assessment because it proposed to a demand of water equivalent to, or greater than, the amount of water required by a 500 dwelling unit project, and/or because it is a proposed industrial use occupying more than 40 acres of land. The Water Supply Assessment (WSA) has been prepared in accordance with Water Code 10912(c) (4); and,

WHEREAS, the Imperial County Board of Supervisors has the authority and responsibility for approving the Water Supply Assessment; and,

WHEREAS, the duty to prepare a Water Supply Assessment falls to the County of Imperial (“County”) because the Imperial Irrigation District (IID) is not a public water system within the meaning of the Water Code 10912(c); and,

WHEREAS, the County, in consultation with an expert engineering firm and the IID prepared the Water Supply Assessment, which includes any and all Water Supply Assessment addendums; and,

WHEREAS, the County has independently reviewed and considered the Water Supply Assessment and the entire administrative record; and,

WHEREAS, public notice of said application has been given, and the Board of Supervisors has considered the recommendation by the Planning Commission, evidence presented by the Imperial County Planning & Development Services Department and other interested parties at a public hearing held with respect to this item on October 24, 2023; and,

NOW THEREFORE, the Board of Supervisors for the County of Imperial **DOES HEREBY APPROVE OF WSA BASED ON THE FOLLOWING FINDINGS:**

SECTION 1. The Board of Supervisors has considered the proposed VEGA SES 4 SOLAR ENERGY STORAGE PROJECT’S WSA prior to deciding to on the approval of WSA. The Board of Supervisors finds and determines that the WSA is adequate and prepared in accordance with the requirements of Water Code, Section 10912(c)(4). The analysis of the WSA demonstrates that the total projected water supplies, determined to be available by the County for the Project during normal, single dry, and multiple dry water years, will meet the projected water demand associated with the proposed project and based upon the following findings and determinations.

SECTION 2. That in accordance with State Planning and Zoning law, the County Board of Supervisors makes the following findings for the approval of the VEGA SES 4 SOLAR ENERGY project:

1. This Water Supply Assessment has determined that IID has adequate polices, programs and projects in place to provide water to agricultural, commercial, industrial, and municipal users in the Imperial Unit. Adequate supply is currently available as well as during normal water years. IID's Equitable Distribution Plan ("EDP") is sufficient to manage water supply during multiple dry water years. Conservation plans and measures are available to reduce the probability of Supply Demand Imbalance ("SDI") from occurring. Adequate agreements, plans and policies are in place that enable the Imperial Unit water supply to be considered reliable for 40 years.
2. IID serves as the regional water supplier, importing raw Colorado River water and delivering it, untreated, to agricultural, municipal, and industrial water users within its Service Area.
3. IID is a raw water retailer and a domestic raw water wholesaler and does not supply potable drinking water.
4. This WSA has shown that IID water supply is adequate for the operations of this Project. IID's IWSP for Non-Agricultural Projects dedicates 25,000 AFY of IID's annual water supply to serve new projects. To date 23,800 AF per year remain available for new industrial projects ensuring reasonably sufficient supplies for new non-agricultural water users and the request for 11 acres feet of water per year is within the remaining balance available.
5. As urban growth continues in Imperial County, agricultural water use may decline due to the transfer of water consumption to other land uses.
6. In the case of a SDI, IID's EDP gives water delivery priority to municipal and industrial users over agricultural users.

NOW, THEREFORE, based on the above findings, the Board of Supervisors of the County of Imperial **DOES HEREBY APPROVE** the Water Supply Assessment (WSA) for VEGA SES 4 SOLAR ENERGY Project.

Ryan E. Kelley, Chairperson
Imperial County Board of Supervisors

I hereby certify that the preceding resolution was taken by the Board of Supervisors at a meeting conducted on October 24, 2023, by the following vote:

AYES:

NOES:

ABSENT:

ABSTAIN:

ATTEST:

Blanca Acosta
Clerk of the Board of Supervisors

Attachment C:
FEIR – FINDINGS-ERRATA

RESOLUTION NO.

A RESOLUTION OF THE BOARD OF SUPERVISORS OF THE COUNTY OF IMPERIAL, FOR THE CERTIFICATION OF THE FINAL PROJECT ENVIRONMENTAL IMPACT REPORT (EIR) FOR THE VEGA SES 4 SOLAR ENERGY PROJECT.

WHEREAS, a Final Project EIR SCH #2021050018 and Candidate CEQA Findings have been prepared in accordance with the requirements of the California Environmental Quality Act, the State CEQA Guidelines, and the County's Rules to Implement CEQA as amended for the VEGA SES 4 SOLAR ENERGY Project that consists of a Water Supply Assessment, an Environmental Impact Report, a Mitigation Monitoring & Reporting Program, and a Conditional Use Permit; and,

WHEREAS, the Board of Supervisors of the County of Imperial has been delegated with the responsibility regarding the certification of the proposed Final Environmental Impact Report (FEIR); and,

WHEREAS, the Final Project EIR has been provided in a timely manner to public agencies; and

WHEREAS, timely public notice of the Board of Supervisors hearing on the Project application has been given. The Board of Supervisors has considered the recommendation for approval by the Board of Supervisors, evidence presented by the Imperial County Planning & Development Services Department and other interested parties at that public hearing held with respect to this item on October 24, 2023; and,

WHEREAS, the Final Project EIR includes analysis of various alternatives as required by CEQA, including the Conditional Use Permit, Mitigation Monitoring & Reporting Program and Water Supply Assessment; and,

NOW THEREFORE, the Board of Supervisors of the County of Imperial **DOES HEREBY RESOLVE** as follows:

SECTION 1. The Board of Supervisors independently has reviewed and considered the proposed Final Environmental Impact Report (FEIR), and Candidate CEQA Findings prior to deciding to approve the proposed FEIR and Findings of Fact. The Board of Supervisors finds and determines that the Environmental Impact Report is adequate and prepared in accordance with the requirements of the California Environmental Quality Act (CEQA), which analyzes environmental effects, based upon the following findings and determinations.

SECTION 2. That in accordance with, CEQA, State Planning and Zoning law and the County of Imperial Land Use Ordinance, the following findings for the recommendation for approval and certification of the FEIR and Findings of Fact have been made as follows:

1. That the Final Project EIR **SCH #2021050018**, Candidate CEQA Findings for the Vega SES Solar Energy ("Project") have been prepared in accordance with the requirements of the California Environmental Quality Act, the State CEQA Guidelines, and the County's

Rules to Implement CEQA as amended, and such findings are incorporated by reference herein.

2. That the County independently has reviewed, analyzed, and considered the Final Project EIR, the environmental impacts therein identified for this Project, the Candidate CEQA Findings, and the Mitigation Monitoring and Reporting Program, and the entire Record of Proceedings prior to recommending approval of this project.

3. That the Final Project EIR and the Candidate CEQA Findings reflect the independent judgment of the County.

4. That the Candidate CEQA Findings are supported by substantial evidence and backed by information provided to the County by experts, including but not limited to the County staff and the EIR preparer, on whom the County relies.

5. That the County accept as its own, incorporate as if set forth in full herein, and make each and every one of the findings contained in the Candidate CEQA Findings, including feasibility of mitigation measures pursuant to Public Resources Code 21081(a)/CEQA Guidelines 15091, and the infeasibility of project alternatives.

6. That the Project will not individually or cumulatively have an unmitigated adverse effect on fish and wildlife resources, as defined in Section 711.2 of the Fish and Game Code.

7. That the Record of Proceedings consists of the Final Project EIR (and all its technical reports and addendums thereto); the County staff reports; the CEQA Findings; the Mitigation Monitoring and Reporting Program; the various Project entitlements and documents referenced therein; all final reports, applications, memoranda, maps, letters, and other planning documents prepared and/or utilized by the EIR planning/environmental consultant; all final reports, memoranda, maps, letters, and other planning documents prepared and/or utilized by the County staff; all documents submitted by members of the public and public agencies in connection with the Final Project EIR; minutes and transcripts of all public meetings and public hearings; all written and verbal public testimony presented during a noticed public hearing for the proposed project which such testimony was taken and any and all other materials which constitute the record of proceeding pursuant to Public Resources Code section 21167.6(e); and matters of common knowledge to the County staff, Planning Commission, and Board of Supervisors, including, but not limited to the County General Plan, the County Zoning Ordinance, and County policies, which may be found at the Clerk's Office located at 940 Main Street, Suite 209, El Centro, CA, 92243 during regular business hours, and the Imperial County Planning & Development Services Department at 801 Main Street, El Centro, CA 92243.

NOW, THEREFORE, based on the above findings, the Board of Supervisors of the County of Imperial **DOES HEREBY APPROVE** the Final EIR **SCH #2021050018**, Candidate CEQA Findings, for the VEGA SES 4 SOLAR ENERGY ("Project").

Ryan E. Kelley, Chairperson
Imperial County Board of Supervisors

I hereby certify that the preceding resolution was taken by the Board of Supervisors at a meeting conducted on October 24, 2023, by the following vote:

AYES:

NOES:

ABSENT:

ABSTAIN:

ATTEST:

Blanca Acosta
Clerk of the Board of Supervisors

**CALIFORNIA ENVIRONMENTAL QUALITY ACT FINDINGS OF FACT
(Public Resource Code §21081, CEQA Guidelines §15091)
Final Environmental Impact Report for the
VEGA SES 4 Solar Energy Project
(State Clearinghouse [SCH] No. 2021050018)**

1 Introduction

The following Findings are made for the Environmental Impact Report SCH #2021050018 (the “EIR”) for the proposed VEGA SES 4 Solar Energy Project (herein referred to as the “project”). The EIR analyzes the significant and potentially significant environmental impacts, which may occur as a result of the project.

The proposed project consists of three primary components: 1) solar energy generation equipment and associated facilities including a substation and access roads (herein referred to as “solar energy facility”); 2) battery energy storage system (BESS); and, 3) gen-tie line that would connect the proposed on-site substation to the point of interconnection at the existing Imperial Irrigation District’s (IID) 92 kilovolt (kV) “P” line. The solar energy facility, BESS, and gen-tie are collectively referred to as the “proposed project” or “project.”

The project site is located on approximately 450 acres of privately-owned land in the southernmost portion of Imperial County, California. The project site is between the U.S./Mexico international border and the All-American Canal, on the California side. It is approximately 10 miles east of the City of Calexico.

The proposed project involves the construction of a 100-megawatt (MW) alternating current (AC) photovoltaic (PV) solar energy facility with an integrated 100 MW battery storage system (not to exceed 200 MW) on approximately 450 acres of land. The project site would be developed with a ground mounted PV solar power generating system, supporting structures, on-site substation, BESS, interconnection facilities, and internal access roads. The project would employ the use of PV power systems to convert solar energy into electricity using non-reflective technology. The electrical energy produced by the project would be conducted through the project’s interconnection facilities to the proposed 92 kV gen-tie line and delivered to the existing IID approved point of interconnection on the 92 kV “P” Line.

1.1 Purpose of CEQA Findings; Terminology

CEQA Findings play an important role in the consideration of projects for which an EIR is prepared. Under Public Resources Code §21081 and CEQA Guidelines §15091 above, where a final EIR identifies one or more significant environmental effects, a project may not be approved until the public agency makes written findings supported by substantial evidence in the administrative record regarding each of the significant effects. In turn, the three possible findings specified in CEQA Guidelines §15091(a) are:

1. Changes or alterations have been required in, or incorporated into, the project, which avoid or substantially lessen the significant environmental effect as identified in the final EIR.
2. Such changes or alterations are within the responsibility and jurisdiction of another public agency and not the agency making the finding. Such changes have been adopted by such other agency or can and should be adopted by such other agency.

3. Specific economic, legal, social, technological, or other considerations, including provision of employment opportunities for highly trained workers, make infeasible the mitigation measures or project alternatives identified in the final EIR.

CEQA Guidelines §15092(b) provides that no agency shall approve a project for which an EIR was prepared unless either:

1. The project approved will not have a significant effect on the environment, or
2. The agency has:
 - a. Eliminated or substantially lessened all significant effects where feasible as shown in the findings under Section 15091, and
 - b. Determined that any remaining significant effects on the environment found to be unavoidable under Section 15091 are acceptable due to overriding concerns as described in Section 15093.

1.2 EIR Process

After the County reviewed the applications for the proposed project, it concluded that the project could have a significant impact on the environment and that preparation of an environmental impact report was determined to be the appropriate CEQA environmental document. The County issued a Notice of Preparation (NOP) on May 4, 2021 and made the NOP available for review and comment for a 35-day period closing on June 7, 2021. The NOP was distributed to city, county, and state and federal agencies, other public agencies, and various interested private organizations and individuals. The NOP was also published in the Imperial Valley Press on May 4, 2021 and in the Calexico Chronicles on May 6, 2021. A public scoping meeting was held on May 13, 2021. Four comment letters were received during the NOP review period. A copy of the NOP and written comments received in response to the NOP are included in Appendix A of the Final EIR.

Based upon comments the County received in response to the NOP, it was determined that the Draft EIR should analyze project related environmental impacts relative to the following 14 substantive potential impact areas in the Environmental Analysis section:

- Aesthetics
- Agricultural Resources
- Air Quality
- Biological Resources
- Cultural Resources
- Geology and Soils
- Greenhouse Gas Emissions
- Hazards and Hazardous Materials
- Hydrology/Water Quality
- Land Use and Planning
- Noise and Vibration

- Transportation
- Tribal Cultural Resources
- Utilities/Service Systems (Water Supply)

Additionally, the Draft EIR was required to include other CEQA substantive sections including an Executive Summary, Introduction, Environmental Setting, Project Description, Analysis of Long-Term Effects, Cumulative Impacts, Effects Found Not Significant, and Alternatives.

The Draft EIR was circulated for a statutory 45-day public review period starting on November 22, 2022 and ending on January 10, 2023 (50 actual days). One letter was received during the comment period and is responded to in the responses to comments section of the Final EIR.

2 Project Location

The project site is located on approximately 450 acres of privately-owned land in the southernmost portion of Imperial County, California. The project site is between the U.S./Mexico international border and the All-American Canal, on the California side. It is approximately 10 miles east of the City of Calexico in Sections 10, 11, 14, 15, and 16 within Township 17 South, and Range 16 East of the San Bernardino Base and Meridian of the Bonds Corner topographic 7.5-minute quadrangle. The irregular shaped project site is bound by undeveloped land, portions of which have been disturbed associated with previous agricultural-related activities to the west and east, the All-American Canal running southwest on the northern border of the project site, and the U.S./Mexico international border to the south. The project site is currently characterized by flat and undeveloped land, portions of which have been disturbed associated with previous agricultural-related activities.

3 Project Description

The proposed project consists of three primary components: 1) solar energy generation equipment and associated facilities including a substation and access roads (herein referred to as “solar energy facility”); 2) BESS; and, 3) gen-tie line that would connect the proposed on-site substation to the point of interconnection at the existing IID 92 kV “P” line.

The proposed project involves the construction and operation of a 100 MW AC PV solar energy facility with an integrated 100 MW battery storage system (not to exceed 200 MW) on approximately 450 acres of land. The project site would be developed with a ground mounted PV solar power generating system, supporting structures, on-site substation, battery storage system, interconnection facilities, and internal access roads. The project would employ the use of PV power systems to convert solar energy into electricity using non-reflective technology.

The County Land Use Ordinance, Division 17, includes the Renewable Energy (RE) Overlay Zone, which authorizes the development and operation of renewable energy projects with an approved conditional use permit (CUP). CUP applications proposed for specific renewable energy projects not located in the RE Overlay Zone would not be allowed without an amendment to the RE Overlay Zone. The entire project site is located within the RE Overlay Zone. Therefore, no General Plan Amendment or Rezone would be required to implement the proposed project.

3.1 Project Objectives

The following are the project objectives:

- Construct and operate a solar energy facility capable of producing up to 100 MW AC of electricity to assist the State of California in achieving its 60 percent renewable portfolio standard by 2030.
- Provide a 100 MW energy BESS, that would accommodate and store the power generated by the project so that the facility can continue to provide renewable energy during non-daylight hours.
- Interconnect directly to IID's existing electrical transmission system.
- Help California meet its statutory and regulatory goal of increasing renewable power generation, including greenhouse gas reduction goals of Senate Bill 32.
- Minimize and mitigate any potential impact to sensitive environmental resources within the project area.

3.2 Discretionary Actions/Approvals by the County of Imperial

The County is the "lead agency" for the proposed project. Lead agency is defined as, "the public agency, which has the principal responsibility for carrying out or approving a project." The County must undertake the following discretionary actions and approvals for the project:

1. **Approval of Conditional Use Permit.** Implementation of the project would require the approval of a conditional use permit (CUP) by the County to allow for the construction and operation of the proposed solar energy facility with an integrated BESS. The project site is located on two privately-owned legal parcels zoned Heavy Agriculture with a Renewable Energy Zone Overlay (A-3-RE). Pursuant to Title 9, Division 5, Chapter 9, the following uses are permitted in the A-3 zone subject to approval of a CUP from Imperial County:
 - i) Battery Storage Facility (must be connected to an existing electrical power generation plant such as solar, geothermal, wind, natural gas, or other renewable energy generator, as an accessory unit to said power plant).*
 - oo) Major facilities relating to the generation and transmission of electrical energy, provided such facilities are not under State or Federal law, to [be] approved exclusively by an agency, or agencies of the State or Federal government, and provided such facilities shall be approved subsequent to coordination review of the Imperial Irrigation District for electrical matters, meeting the requirements in Division 17.*
 - zz) Solar energy plants meeting the requirements in Division 17.*
2. **Certification of the EIR.** After the required public review for the Draft EIR, the County will respond to written comments, edit the document, and produce a Final EIR to be certified by the Planning Commission and Board of Supervisors prior to making a decision on approval or denial of the project.

Subsequent ministerial approvals may include, but are not limited to:

- Grading and clearing permits
- Building permits
- Reclamation plan
- Encroachment permits
- Transportation permit(s)

3.3 Discretionary Actions/Approvals by Other Agencies

Responsible Agencies are those agencies that have discretionary approval over one or more actions involved with development of the project. Trustee Agencies are state agencies that have discretionary approval or jurisdiction by law over natural resources affected by a project. These agencies may include, but are not limited to the following:

- California RWQCB – Notice of Intent for General Construction Permit, CWA 401 Water Quality Certification
- ICAPCD – Fugitive Dust Control Plan, Rule 801 Compliance
- CDFW (Trustee Agency) – ESA Compliance, Section 1600 Streambed Alteration Agreement
- USFWS – ESA Compliance
- USACE – Section 404 of the CWA Permit
- IID – Water Supply Agreement
- IID - Potential Upgrades to the existing Ramon Substation

3.4 Memorandum of Understanding – U.S. Border Patrol/Department of Homeland Security

The project applicant and U.S. Border Patrol (USBP) will develop and enter into a Memorandum of Understanding (MOU) setting forth the project-related activities that may occur on an existing dirt road used by the USBP.

- Project applicant will provide an additional 60 feet of right-of-way along its southern end of the property to allow for additional protective area for the U.S. Border Patrol Services functions.
- Project applicant will install a 6-foot-high chain link fence with barb wire on top surrounding the project site.
- Project applicant will provide a mechanism acceptable to USBP for access to the site upon completion of the construction in the event USBP needs to enter for enforcement purposes.
- Project applicant will provide full-time security during construction of the project and will coordinate with USBP on this service.
- Project applicant will provide contact information for both construction phases and operation phases to make sure USBP has direct contact information.
- Project applicant will maintain the road between the site and its terminus at the I-8/HWY 98 intersection during the construction of the site in a manner prescribed by USBP. At a minimum

this will be routine watering and as necessary grading. No material will be added to the road without approval from USBP. Additionally, no work will be done adjacent to the road that would interfere with USBP's "brushing" program.

- Project applicant will have an agreement with U.S. Bureau of Reclamation for the pedestrian traffic crossing at the IID drop and will observe USBP protocols for all people crossing for the project both during construction and future operations.
- Project applicant will notify the USBP's designated representative prior to any use of the road from Gordons Well access to the site.
- USBP will immediately contact designated project representatives if they encounter a problem at the site in an effort to give project applicant an opportunity to cure.

2.7.4 Bureau of Land Management – California Desert District U.S. Department of the Interior – Region 8 El Centro Field Office

- The project applicant will be required to obtain a Right of Way (ROW) from the Bureau of Land Management (BLM) for any heavy equipment access routes that may traverse BLM managed public lands. Should the proposed Gordon Wells Road heavy equipment access route not be utilized, a second option is proposed utilizing Grays Wells Road as described in further detail in Chapter 2 Project description.

4 Issues Addressed In the EIR

Based on the analysis presented in the NOP and the information provided in the comments to the NOP, the following environmental topics were analyzed in the EIR.

- Aesthetics
- Agriculture Resources
- Air Quality
- Biological Resources
- Cultural Resources
- Geology and Soils
- GHG Emissions
- Hazards and Hazardous Materials
- Hydrology/Water Quality
- Land Use/Planning
- Noise and Vibration
- Transportation
- Tribal Cultural Resources



- Utilities/Service Systems (Water Supply)

5 Mitigation Monitoring Program

Pursuant to PRC §21081.6, the County has adopted a detailed mitigation and monitoring program prepared under the County's direction. The program is designed to ensure that all mitigation measures as hereafter required are in fact implemented on a timely basis as the project is implemented.

6 Record of Proceedings

For all purposes of CEQA compliance, including these Findings of Fact, the administrative record of all County proceedings and decisions regarding the environmental analysis of the project include but are not limited to:

- The Draft and Final EIR for the project, together with all appendices and technical reports referred to therein, whether separately bound or not, or on a CD;
- All reports, letters, applications, memoranda, maps or other planning and engineering documents prepared by the County, its planning consultant and environmental consultant, the applicant or others and presented to or before the decision-makers or staff;
- All minutes of any public workshops, meetings or hearings, and any recorded or verbatim transcripts or videotapes thereof;
- Any letters, reports or other documents or evidence submitted into the record at any public workshops, meetings or hearings; and
- Matters of common general knowledge to the County which it may consider, including applicable state or local laws, ordinances and policies, the General Plan and all applicable planning programs and policies of the County.

Documents or other materials that constitute the record of proceedings upon which these Findings are made are located at the Department of Planning and Development Services of the County of Imperial, 801 Main Street, El Centro, CA 92243.

7 Findings of Significant Impacts, Required Mitigation Measures and Supporting Facts

The County, having reviewed and considered the information contained in the EIR and the entire administrative record, including but not limited to the expert opinions of the County's professional planning staff and independent consultants familiar with the environmental conditions of the County and the facts and circumstances of the project who prepared the EIR, finds pursuant to Public Resources Code §21081(a)(1) and Guidelines §15091(a)(1) that changes or alterations have been required in, or incorporated into, the project which would mitigate, avoid, or substantially lessen to below a level of significance the following potential significant environmental effects identified in the EIR.

7.1 Agricultural Resources

7.1.1 Involve Other Changes that Could Result in Conversion of Farmland to Non-Agricultural Use

- A. **Potential Impact.** Implementation of the project may result in changing the physical and chemical makeup of the soil materials within the upper soil horizon at the project site. Improper soil stockpiling and management of the stockpiles could result in increased decomposition of soil organic materials, increased leaching of plant available nitrogen, and depletion of soil biota communities. Any reductions in agricultural productivity could significantly limit the types of crops that may be grown within the project site in the future. Additionally, there is the potential that weeds or other pests may occur within the solar field if the area is not properly maintained and managed to control weeds and pests. The potential adverse effect on agricultural productivity is considered a significant impact under CEQA.
- B. **Finding.** Pursuant to CEQA Guidelines §15091 (a)(1), changes or alterations have been required in, or incorporated into, the project which avoid or substantially lessen the significant environmental effect as identified in the Final EIR.

Facts in Support of Finding. Based on the analysis provided in Section 3.3 of the Final EIR, the project's potentially significant impact would be mitigated to below a level of significance with the implementation of Mitigation Measures AG-1 of the Final EIR as identified below. Implementation of Mitigation Measure AG-1 would require the project applicant to prepare and submit a Pest Management Plan to the County of Imperial Agricultural Commissioner for approval. The project applicant will be required to implement the strategies contained in the Pest Management Plan until reclamation is complete on the project site. Additionally, as a condition of project approval (CUP condition), the project applicant or its successor in interest will be responsible for implementing a reclamation plan when the project is decommissioned at the end of its lifespan.

Mitigation Measure AG-1 - Pest Management Plan. Prior to the issuance of a grading permit or building permit (whichever occurs first), a Pest Management Plan shall be developed by the project applicant and approved by the County of Imperial Agricultural Commissioner. The project applicant shall maintain a Pest Management Plan until reclamation is complete. The plan shall provide the following:

1. Monitoring, preventative, and management strategies for weed and pest control during construction activities at any portion of the project (e.g., transmission line);
2. Control and management of weeds and pests in areas temporarily disturbed during construction where native seed will aid in site revegetation as follows:
 - Monitor for all pests including insects, vertebrates, weeds, and pathogens. Promptly control or eradicate pests when found, or when notified by the Agricultural Commissioner's office that a pest problem is present on the project site. The assistance of a licensed pest control advisor is recommended. All treatments must be performed by a qualified applicator or a licensed pest control business;

- All treatments must be performed by a qualified applicator or a licensed pest control operator;
 - "Control" means to reduce the population of common pests below economically damaging levels, and includes attempts to exclude pests before infestation, and effective control methods after infestation. Effective control methods may include physical/mechanical removal, bio control, cultural control, or chemical treatments;
 - Use of "permanent" soil sterilants to control weeds or other pests is prohibited because this would interfere with reclamation;
 - Notify the Agricultural Commissioner's office immediately regarding any suspected exotic/invasive pest species as defined by the California Department of Food Agriculture and the U.S. Department of Agriculture. Request a sample be taken by the Agricultural Commissioner's Office of a suspected invasive species. Eradication of exotic pests shall be done under the direction of the Agricultural Commissioner's Office and/or California Department of Food and Agriculture;
 - Obey all pesticide use laws, regulations, and permit conditions;
 - Allow access by Agricultural Commissioner staff for routine visual and trap pest surveys, compliance inspections, eradication of exotic pests, and other official duties;
 - Ensure all project employees that handle pest control issues are appropriately trained and certified, all required records are maintained and made available for inspection, and all required permits and other required legal documents are current;
 - Maintain records of pests found and treatments or pest management methods used. Records should include the date, location/block, project name (current and previous if changed), and methods used. For pesticides include the chemical(s) used, EPA Registration numbers, application rates, etc. A pesticide use report may be used for this;
 - Submit a report of monitoring, pest finds, and treatments, or other pest management methods to the Agricultural Commissioner quarterly within 15 days after the end of the previous quarter, and upon request. The report is required even if no pests were found or treatment occurred. It may consist of a copy of all records for the previous quarter or may be a summary letter/report as long as the original detailed records are available upon request.
2. A long-term strategy for weed and pest control and management during the operation of the proposed project. Such strategies may include, but are not limited to:
- Use of specific types of herbicides and pesticides on a scheduled basis.
3. Maintenance and management of project site conditions to reduce the potential for a significant increase in pest-related nuisance conditions on surrounding agricultural lands.

4. The project shall reimburse the Agricultural Commissioner's office for the actual cost of investigations, inspections, or other required non-routine responses to the site that are not funded by other sources.

7.2 Air Quality

7.2.1 Air Quality Emissions - Construction

- A. **Potential Impact.** As shown in Final EIR Table 3.4-7, the project's daily construction emissions would not exceed the ICAPCD thresholds for ROG, NO_x, CO, SO₂, and PM_{2.5}. However, the project would exceed the ICAPCD threshold for PM₁₀ and is considered a significant impact.
- B. **Finding.** Pursuant to CEQA Guidelines §15091 (a)(1), changes or alterations have been required in, or incorporated into, the project which avoid or substantially lessen the significant environmental effect as identified in the Final EIR.
- C. **Facts in Support of Finding.** Pursuant to the Imperial County Air Pollution Control District (ICAPCD), all construction sites, regardless of size, must comply with the requirements contained within Regulation VIII – Fugitive Dust Control Measures. The project must comply with the requirements of ICAPCD Regulation VIII for the control of fugitive dust. A predominate source of project PM₁₀ emissions is workers commuting to and from the project site on unpaved roads (worker access and heavy construction equipment access routes described above). Regulation VIII requires all unpaved roadways, on- and off-site, to be conditioned and maintained with soil stabilizers to reduce dust opacity to no more than 20 percent; all unpaved disturbed surfaces, on- and off-site, to be stabilized with a dust suppressant, watering, or soil stabilizers to reduce opacity to no greater than 20 percent; and to reduce vehicle speed to no greater than 15 mph on all unpaved surfaces. Final EIR Table 3.4-8 shows the project's emissions with implementation of the Regulation VIII fugitive dust control measures (Mitigation Measure AQ-1). With implementation of Mitigation Measure AQ-1, the project would not exceed the ICAPCD's thresholds of significance for PM₁₀ emissions.

In addition, as described in Mitigation Measure AQ-2, construction equipment shall be equipped with an engine designation of EPA Tier 2 or better (Tier 2+). A list of the construction equipment, including all off-road equipment utilized at the project site by make, model, year, horsepower and expected/actual hours of use, and the associated EPA Tier shall be submitted to the County Planning and Development Services Department and ICAPCD prior to the issuance of a grading permit. The equipment list shall be submitted periodically to ICAPCD to perform a NO_x analysis. ICAPCD shall utilize this list to calculate air emissions to verify that equipment use does not exceed significance thresholds.

Mitigation Measure AQ-1 - Fugitive Dust Control. During construction activities, the constructor contractor shall employ the following PM₁₀ reducing measures:

1. All unpaved roads associated with construction shall be effectively stabilized of dust emissions using Imperial County Air Pollution Control District-approved chemical stabilizers/suppressant before the commencement of construction, and

every 30 days thereafter until the end of all construction activities. Unpaved roads associated with construction include:

- The driveway entrance off State Route 98,
- The project designated 3.5-acre staging/parking area north of the All-American Canal,
- The 1.0 mile of dirt road south of the All-American Canal,
- The 20 miles of existing dirt road paralleling the U.S./Mexico Border from Gordon Wells Road to the project site.

Monthly application of Imperial County Air Pollution Control District-approved chemical stabilizers/suppressant shall be applied at a rate of 0.1 gallon/ square yard of chemical dust suppressant.

2. Prior to any earthmoving activity, the applicant shall submit a construction dust control plan and obtain Imperial County Air Pollution Control District and Imperial County Planning and Development Services Department (ICPDS) approval.
3. Pursuant to ICAPCD, all construction sites, regardless of size, must comply with the requirements contained within Regulation VIII – Fugitive Dust Control Measures. Whereas these Regulation VIII measures are mandatory and are not considered project environmental mitigation measures, the ICAPCD CEQA Handbook's required additional standard and enhanced mitigation measures listed below shall be implemented prior to and during construction. ICAPCD will verify implementation and compliance with these measures as part of the grading permit review/approval process.

ICAPCD Standard Measures for Fugitive Dust (PM₁₀) Control

- All disturbed areas, including bulk material storage, which is not being actively utilized, shall be effectively stabilized and visible emissions shall be limited to no greater than 20 percent opacity for dust emissions by using water, chemical stabilizers, dust suppressants, tarps, or other suitable material, such as vegetative ground cover.
- All on-site and off-site unpaved roads will be effectively stabilized, and visible emissions shall be limited to no greater than 20 percent opacity for dust emissions by paving, chemical stabilizers, dust suppressants, and/or watering.
- All unpaved traffic areas 1 acre or more with 75 or more average vehicle trips per day will be effectively stabilized and visible emissions shall be limited to no greater than 20 percent opacity for dust emissions by paving, chemical stabilizers, dust suppressants, and/or watering.
- The transport of bulk materials shall be completely covered unless 6 inches of freeboard space from the top of the container is maintained with no spillage and loss of bulk material. In addition, the cargo compartment of all haul trucks is to be cleaned and/or washed at delivery site after removal of bulk material.

- All track-out or carry-out will be cleaned at the end of each workday or immediately when mud or dirt extends a cumulative distance of 50 linear feet or more onto a paved road within an urban area.
- Movement of bulk material handling or transfer shall be stabilized prior to handling or at points of transfer with application of sufficient water, chemical stabilizers, or by sheltering or enclosing the operation and transfer line.
- The construction of any new unpaved road is prohibited within any area with a population of 500 or more unless the road meets the definition of a temporary unpaved road. Any temporary unpaved road shall be effectively stabilized, and visible emissions shall be limited to no greater than 20 percent opacity for dust emission by paving, chemical stabilizers, dust suppressants, and/or watering.

ICAPCD “Discretionary” Measures for Fugitive Dust (PM₁₀) Control

- Water exposed soil only in those areas where active grading and vehicle movement occurs with adequate frequency to control dust.
- Replace ground cover in disturbed areas as quickly as possible.
- Automatic sprinkler system installed on all soil piles.
- Vehicle speed for all construction vehicles shall not exceed 15 miles per hour on any unpaved surface at the construction site.
- Develop a trip reduction plan to achieve a 1.5 average vehicle ridership for construction employees.
- Implement a shuttle service to and from retail services and food establishments during lunch hours.

Standard Mitigation Measures for Construction Combustion Equipment

- Use of alternative fueled or catalyst equipped diesel construction equipment, including all off-road and portable diesel-powered equipment.
- Minimize idling time either by shutting equipment off when not in use or reducing the time of idling to 5 minutes as a maximum.
- Limit, to the extent feasible, the hours of operation of heavy-duty equipment and/or the amount of equipment in use.
- Replace fossil fueled equipment with electrically driven equivalents (provided they are not run via a portable generator set).

Enhanced Mitigation Measures for Construction Equipment

To help provide a greater degree of reduction of PM emissions from construction combustion equipment, ICAPCD recommends the following enhanced measures.

- Curtail construction during periods of high ambient pollutant concentrations; this may include ceasing of construction activity during the peak hour of vehicular traffic on adjacent roadways.
- Implement activity management (e.g., rescheduling activities to reduce short-term impacts).

Mitigation Measure AQ-2 - Construction Equipment. Construction equipment shall be equipped with an engine designation of EPA Tier 2 or better (Tier 2+). A list of the construction equipment, including all off-road equipment utilized at the project site by make, model, year, horsepower and expected/actual hours of use, and the associated EPA Tier shall be submitted to the County Planning and Development Services Department and ICAPCD prior to the issuance of a grading permit. The equipment list shall be submitted periodically to ICAPCD to perform a NO_x analysis. ICAPCD shall utilize this list to calculate air emissions to verify that equipment use does not exceed significance thresholds. The Planning and Development Services Department and ICAPCD shall verify implementation of this measure.

7.2.2 Air Quality Emissions - Operation

- A. **Potential Impact.** The proposed project requires minimal operations and maintenance activities conducted by two to three employees. Long-term operational emissions attributable to the project are identified in Final EIR Table 3.4-9 and compared to the operational significance thresholds promulgated by the ICAPCD. As shown in Final EIR Table 3.4-9, the project's operational emissions would not exceed the ICAPCD thresholds for CO, ROG, NO_x, PM₁₀ and PM_{2.5}. Although no significant air quality impact would occur during operation, the project applicant is required to submit a Dust Suppression Management Plan for both construction and operation in order to reduce fugitive dust emissions. Implementation of Mitigation Measures AQ-1, AQ-3 and AQ-4 would ensure that a Dust Suppression Management Plan is implemented, thereby ensuring that this potential impact would remain less than significant.
- B. **Finding.** Pursuant to CEQA Guidelines §15091 (a)(1), changes or alterations have been required in, or incorporated into, the project which avoid or substantially lessen the significant environmental effect as identified in the Final EIR.
- C. **Facts in Support of Finding.** Based on the analysis provided in Section 3.4 of the Final EIR, no significant air quality impact would occur during operation. Although no significant air quality impact would occur during operation, the project applicant is required to submit a Dust Suppression Management Plan for both construction and operation in order to reduce fugitive dust emissions. Implementation of Mitigation Measures AQ-1, AQ-3 and AQ-4 would ensure that a Dust Suppression Management Plan is implemented, thereby ensuring that this potential impact would remain less than significant.

Mitigation Measure AQ-1 - Fugitive Dust Control (as described above)

Mitigation Measure AQ-3 - Dust Suppression. The project applicant shall employ a method of dust suppression (such as water or chemical stabilization) approved by ICAPCD. The project applicant shall apply chemical stabilization as directed by the product manufacturer to control dust between the panels as approved by ICAPCD, and other non-used areas (exceptions will be the paved entrance and parking area, and Fire Department access/emergency entry/exit points as approved by Fire/Office of Emergency Services [OES] Department).

Mitigation Measure AQ-4 - Operational Dust Control Plan. Prior to issuance of a Certificate of Occupancy, the applicant shall submit an operations dust control plan and obtain ICAPCD and ICPDS approval.

ICAPCD Rule 301 Operational Fees apply to any project applying for a building permit. At the time that building permits are submitted for the proposed project, ICAPCD shall review the project to determine if Rule 310 fees are applicable to the project.

7.3 Biological Resources

7.3.1 Special-Status Plant Species

- A. **Potential Impact.** There is moderate potential for three rare plant species, Abram's spurge, Wiggins' croton, and sand food, to be present within the project area. Suitable habitat for these species is present within the creosote bush scrub and disturbed creosote bush – white bursage scrub habitats. Impacts that may occur to the species during project construction includes loss of individuals, habitat, and seedbank. Depending on the size of the population, potential impacts could be significant.
- B. **Finding.** Pursuant to CEQA Guidelines §15091 (a)(1), changes or alterations have been required in, or incorporated into, the project which avoid or substantially lessen the significant environmental effect as identified in the Final EIR.
- C. **Facts in Support of Finding.** Based on the analysis provided in Section 3.5 of the Final EIR, the project's potential impacts on special-status plant species would be mitigated to below a level of significance with implementation of Mitigation Measures BIO-1 through BIO-3 of the Final EIR. Mitigation Measure BIO-1 requires the project applicant to conduct rare plant surveys prior to initiating ground disturbance.

Mitigation Measure BIO-2 requires implementation of general impact avoidance and minimization measures during construction such as designating a Project Biologist to oversee compliance with protective measures for biological resources, delineating construction zones, and working and traveling only in designated work areas and access roads. Mitigation Measure BIO-3 requires all construction personnel to complete a Worker Environmental Awareness Program prior to the start of construction.

Mitigation Measure BIO-1 - Rare Plant Surveys. Prior to initiating ground disturbance, rare plant surveys shall be conducted within suitable habitat on the project site during the appropriate blooming period for the Abrams' spurge (approximately September through November), Wiggins' croton (approximately March through May), and sand food (approximately April through June). The surveys shall be conducted by a botanist or qualified biologist in accordance with the USFWS Guidelines for Conducting and Reporting Botanical Inventories for Federally Listed, Proposed, and Candidate Plants (USFWS 1996); the CDFW Protocols for Surveying and Evaluating Impacts to Special Status Native Plant Populations and Sensitive Natural Communities (CDFW 2018); and the CNPS Botanical Survey Guidelines (CNPS 2001). If any special-status species are observed during the rare plant surveys, the location of the individual plant or population will be recorded with a submeter GPS device for mapping purposes. If project-related impacts to rare plants on the project site are unavoidable,

then consultation with CDFW may be required to develop a mitigation plan or additional avoidance and minimization measures. Mitigation measures that may be implemented if the species is observed include establishing a no-disturbance buffer around locations of individuals or a population, salvage or seed collection, and additional monitoring requirements.

Mitigation Measure BIO-2 - General Impact Avoidance and Minimization Measures. The following measures will be applicable throughout the life of the project:

- To reduce the potential indirect impact on migratory birds, bats and raptors, the project will comply with the APLIC 2012 Guidelines for overhead utilities, as appropriate, to minimize avian collisions with transmission facilities (APLIC 2012)
- All electrical components on the project site shall be either undergrounded or protected so that there will be no exposure to wildlife and therefore no potential for electrocution.
- The project proponent shall designate a Project Biologist who shall be responsible for overseeing compliance with protective measures for the biological resources during vegetation clearing and work activities within and adjacent to areas of native habitat. The Project Biologist will be familiar with the local habitats, plants, and wildlife. The Project Biologist will also maintain communications with the Contractor to ensure that issues relating to biological resources are appropriately and lawfully managed and monitor construction. The Project Biologist will monitor activities within construction areas during critical times, such as vegetation removal, the implementation of Best Management Practices (BMP), and installation of security fencing to protect native species. The Project Biologist will ensure that all wildlife and regulatory agency permit requirements, conservation measures, and general avoidance and minimization measures are properly implemented and followed.
- The boundaries of all areas to be newly disturbed (including solar facility areas, staging areas, access roads, and sites for temporary placement of construction materials and spoils) will be delineated with stakes and flagging prior to disturbance. All disturbances, vehicles, and equipment will be confined to the flagged areas.
- No potential wildlife entrapments (e.g., trenches, bores) will be left uncovered overnight. Any uncovered pitfalls will be excavated to 3:1 slopes at the ends to provide wildlife escape ramps. Alternatively, man-made ramps may be installed. Covered pitfalls will be covered completely to prevent access by small mammals or reptiles.
- To avoid wildlife entrapment (including birds), all pipes or other construction materials or supplies will be covered or capped in storage or laydown area, and at the end of each workday in construction, quarrying and processing/handling areas. No pipes or tubing of sizes or inside diameters ranging from 1 to 10 inches will be left open either temporarily or permanently.

- No anticoagulant rodenticides, such as Warfarin and related compounds (indandiones and hydroxycoumarins), may be used within the project site, on off-site project facilities and activities, or in support of any other project activities.
- Avoid wildlife attractants. All trash and food-related waste shall be placed in self-closing containers and removed regularly from the site to prevent overflow. Workers shall not feed wildlife. Water applied to dirt roads and construction areas for dust abatement shall use the minimal amount needed to meet safety and air quality standards to prevent the formation of puddles, which could attract wildlife. Pooled rainwater or floodwater within retention basins will be removed to avoid attracting wildlife to the active work areas.
- To minimize the likelihood for vehicle strikes on wildlife, speed limits will not exceed 15 miles per hour when driving on access roads. All vehicles required for O&M must remain on designated access/maintenance roads.
- Avoid night-time construction lighting or if nighttime construction cannot be avoided use shielded directional lighting pointed downward and towards the interior of the project site, thereby avoiding illumination of adjacent natural areas and the night sky.
- All construction equipment used for the Project will be equipped with properly operating and maintained mufflers.
- Hazardous materials and equipment stored overnight, including small amounts of fuel to refuel hand-held equipment, will be stored within secondary containment when within 50 feet of open water to the fullest extent practicable. Secondary containment will consist of a ring of sandbags around each piece of stored equipment/structure. A plastic tarp/Visqueen lining with no seams shall be placed under the equipment and over the edges of the sandbags, or a plastic hazardous materials secondary containment unit shall be utilized by the Contractor.
- The Contractor will be required to conduct vehicle refueling in upland areas where fuel cannot enter waters of the U.S. and in areas that do not have potential to support federally threatened or endangered species. Any fuel containers, repair materials, including creosote-treated wood, and/or stockpiled material that is left on site overnight, will be secured in secondary containment within the work area and staging/assembly area and covered with plastic at the end of each work day.
- In the event that no activity is to occur in the work area for the weekend and/or a period of time greater than 48 hours, the Contractor will ensure that all portable fuel containers are removed from the project site.
- All equipment will be maintained in accordance with manufacturer's recommendations and requirements.
- Equipment and containers will be inspected daily for leaks. Should a leak occur, contaminated soils and surfaces will be cleaned up and disposed of following the guidelines identified in the Stormwater Pollution Prevention Plan or equivalent, Materials Safety Data Sheets, and any specifications required by other permits issued for the project.

- The Contractor will utilize off-site maintenance and repair shops as much as possible for maintenance and repair of equipment.
- If maintenance of equipment must occur onsite, fuel/oil pans, absorbent pads, or appropriate containment will be used to capture spills/leaks within all areas. Where feasible, maintenance of equipment will occur in upland areas where fuel cannot enter waters of the U.S. and in areas that do not have potential to support federally threatened or endangered species.
- Appropriate BMPs will be used by the Contractor to control erosion and sedimentation and to capture debris and contaminants from bridge construction to prevent their deposition in waterways. No sediment or debris will be allowed to enter the creek or other drainages. All debris from construction of the bridge will be contained so that it does not fall into channel. Appropriate BMPs will be used by the Contractor during construction to limit the spread of resuspended sediment and to contain debris.
- Erosion and sediment control devices used for the proposed project, including fiber rolls and bonded fiber matrix, will be made from biodegradable materials such as jute, with no plastic mesh, to avoid creating a wildlife entanglement hazard.
- Firearms, open fires, and pets would be prohibited at all work locations and access roads. Smoking would be prohibited along the Project alignment.
- Cross-country vehicle and equipment use outside of approved designated work areas and access roads shall be prohibited to prevent unnecessary ground and vegetation disturbance.
- Any injured or dead wildlife encountered during project-related activities shall be reported to the project biologist, biological monitor, CDFW, or a CDFW-approved veterinary facility as soon as possible to report the observation and determine the best course of action. For special-status species, the Project Biologist shall notify the County, USFWS, and/or CDFW, as appropriate, within 24 hours of the discovery.
- Stockpiling of material will be allowed only within established work areas.
- Actively manage the spread of noxious weeds
- The ground beneath all parked equipment and vehicles shall be inspected for wildlife before moving.

Mitigation Measure BIO-3 - Worker Environmental Awareness Program. Prior to project construction, a Worker Environmental Awareness Program shall be developed and implemented by a qualified biologist and shall be available in both English and Spanish. Handouts summarizing potential impacts to special-status biological resources and the potential penalties for impacts to these resources shall be provided to all construction personnel. At a minimum, the education program shall include the following:

- The purpose for resource protection;

- A description of special-status species including representative photographs and general ecology;
- Occurrences of USACE, RWQCB, and CDFW regulated features in the Project study area;
- Regulatory framework for biological resource protection and consequences if violated
- Sensitivity of the species to human activities;
- Avoidance and minimization measures designed to reduce the impacts to special-status biological resources;
- Environmentally responsible construction practices;
- Reporting requirements;
- The protocol to resolve conflicts that may arise at any time during the construction process; and
- Workers sign acknowledgement form indicating that the Environmental Awareness Training and Education Program that has been completed and would be kept on record.

7.3.2 Special-Status Wildlife Species

- A. **Potential Impact.** Five special-status wildlife species were observed on site during the habitat assessment: black-tailed gnatcatcher, northern harrier, burrowing owl, yellow warblers, and loggerhead shrikes were observed in the tamarisk thickets in the western portion of the project site. Burrowing owl and their burrows were observed within the disturbed creosote-white bursage scrub in the western portion of the project site, within a berm adjacent to the access road, and in a concrete pile in the northeastern corner of the site. Direct construction-related impacts to wildlife species that could occur include injury, mortality, nest failures, and loss of young. Indirect impacts include increase in anthropogenic effects (i.e., noise levels, introduction of invasive/nonnative species, increase in human activity, and increase in dust.

Northern harriers are ground nesters; therefore, the tamarisk thicket and disturbed arrow weed thicket habitats provide potential nesting habitat for this species. Direct impacts to nesting avian species include injury, mortality, loss of young, and nest failure. Indirect impacts include loss of foraging and nesting habitat for passerine and raptors species, increase in noise and human activities, and potential introduction of invasive/nonnative species.

The use of this access road during construction is not anticipated to result in potential impacts on biological resources, with the exception of roosting bats, if present. Bat acoustic surveys and monitoring should be implemented to determine if sensitive bat species occur within the Gordon Road Wells bridge or palm trees (if planned for removal). All bat species with potential for occurrence for the project are SSC species and potential project-related impacts to bat species and bat maternity roosts are considered significant.

- B. **Finding.** Pursuant to CEQA Guidelines §15091 (a)(1), changes or alterations have been required in, or incorporated into, the project which avoid or substantially lessen the significant environmental effect as identified in the Final EIR.
- C. **Facts in Support of Finding.** Based on the analysis provided in Section 3.5 of the Final EIR, the project's potential impacts on special-status wildlife species would be mitigated to below a level of significance with implementation of Mitigation Measures BIO-2 through BIO-7 of the Final EIR. Mitigation Measure BIO-2 requires implementation of general impact avoidance and minimization measures during construction such as designating a Project Biologist to oversee compliance with protective measures for biological resources, delineating construction zones, and working and traveling only in designated work areas and access roads. Mitigation Measure BIO-3 requires all construction personnel to complete a Worker Environmental Awareness Program prior to the start of construction.

Mitigation Measure BIO-4 requires pre-construction surveys for burrowing owl. If burrowing owl is identified during the breeding season (February 1 through August 31), then an appropriate buffer will be established by the biological monitor in accordance with the *Staff Report on Burrowing Owl Mitigation* (CDFG 2012). Construction within the buffer will be avoided until a qualified biologist determines that burrowing owl is no longer present or until young have fledged. Mitigation Measure BIO-5 requires a pre-construction nesting bird survey to be conducted by a qualified avian biologist to ensure that active bird nests, including those for the black-tailed gnatcatcher, northern harrier, yellow warbler, burrowing owl, and loggerhead strike will not be disturbed or destroyed. Mitigation Measure BIO-6 requires a pre-construction survey to be conducted for special-status wildlife species within all areas of potential permanent and temporary disturbance. Mitigation Measure BIO-7 requires a qualified bat biologist to conduct an appropriate combination of sampling, exit counts, and acoustic surveys to determine if bats are using the palm tree resources in the project area.

Mitigation Measure BIO-2 - General Impact Avoidance and Minimization Measures (as described above)

Mitigation Measure BIO-3 - Worker Environmental Awareness Program (as described above)

Mitigation Measure BIO-4 - Burrowing Owl Avoidance and Minimization. Take Avoidance (pre-construction) surveys for burrowing owl shall be completed prior to project construction. Surveys shall be conducted as detailed within Appendix E of the *Staff Report on Burrowing Owl Mitigation* (California Department of Fish and Game [CDFG] 2012). If burrowing owl is not detected, construction may proceed.

- If burrowing owl is identified during the non-breeding season (September 1 through January 31), then a 50-meter buffer will be established by the biological monitor. Construction within the buffer will be avoided until a qualified biologist determines that burrowing owl is no longer present or until a CDFW-approved exclusion plan has been implemented. The buffer distance may be reduced if noise attenuation buffers such as hay bales are placed between the occupied burrow and construction activities.

- If burrowing owl is identified during the breeding season (February 1 through August 31), then an appropriate buffer will be established by the biological monitor in accordance with the *Staff Report on Burrowing Owl Mitigation* (CDFG 2012). Construction within the buffer will be avoided until a qualified biologist determines that burrowing owl is no longer present or until young have fledged. The buffer distance may be reduced in consultation with CDFW if noise attenuation buffers such as hay bales are placed between the occupied burrow and construction activities.

Mitigation Measure BIO-5 - Pre-Construction Nesting Bird Survey. If construction or other project activities are scheduled to occur during the bird breeding season (typically February 1 through August 31 for raptors and March 15 through August 31 for the majority of migratory bird species), a pre-construction nesting-bird survey shall be conducted by a qualified avian biologist to ensure that active bird nests, including those for the black-tailed gnatcatcher, northern harrier, yellow warbler, burrowing owl, and loggerhead strike, will not be disturbed or destroyed. The survey shall be completed no more than three days prior to initial ground disturbance. The nesting-bird survey shall include the project site and adjacent areas where project activities have the potential to affect active nests, either directly or indirectly due to construction activity or noise. If an active nest is identified, the biologist shall establish an appropriately sized disturbance-limit buffer around the nest using flagging or staking. Construction activities shall not occur within any disturbance-limit buffer zones until the nest is deemed inactive by the qualified biologist. If construction activities cease for a period of greater than three days during the bird breeding season, a pre-construction nesting bird survey shall be conducted prior to the commencement of activities. Final construction buffers or setback distances shall be determined by the qualified biologist in coordination with USFWS and CDFW on a case-by-case basis, depending on the species, season in which disturbance shall occur, the type of disturbance, and other factors that could influence susceptibility to disturbance (topography, vegetation, existing disturbance levels, etc.).

Mitigation Measure BIO-6 - Pre-Construction Survey for Special-Status Species. A pre-construction survey shall be conducted for special-status wildlife species within all areas of potential permanent and temporary disturbance. The pre-construction survey shall take place no more than 14 days prior to the start of ground-disturbing activities. The pre-construction surveys should take place regardless of breeding season timing and shall focus on identifying the presence of special-status wildlife species present on the project site or that were identified as having a high potential to occur on the site. These species include, but are not limited to, flat-tailed horned lizard, burrowing owl, northern harrier, black-tailed gnatcatcher, and yellow warbler. Should any special-status species be identified during the pre-construction survey, consultation to develop suitable avoidance and minimization measures with the appropriate agency (USFWS, CDFW) may need to be undertaken.

Mitigation Measure BIO-7 - Bat Acoustic Surveys and Monitoring. To avoid impacts to bat species, a qualified bat biologist shall conduct an appropriate combination of sampling, exit counts, and acoustic surveys to determine if bats are using the palm tree resources in the project area. If project-related impacts to bat

species are unavoidable, additional measures may need to be implemented to reduce or eliminate impacts to bat species, including maternity roosts, such as tree removal occurring outside of bat breeding season (October through February) or two-step, two-day removal of palm trees under supervision of a qualified bat biologist.

7.4 Cultural Resources

7.4.1 Historical Resources

- A. **Potential Impact.** Five cultural resources are being treated as eligible for listing in the California Register of Historical Resources as historical resources under CEQA. The proposed project has been designed to avoid Sites 2020-142-001, 2020-142-002, 2020-142-004, 2020-142-005, and 2020-142-008. The project applicant will avoid ground-disturbing activities within and in close proximity to these resources. However, if-ground disturbing activities must occur within and in close proximity to these resources, a significant impact may potentially occur.
- B. **Finding.** Pursuant to CEQA Guidelines §15091 (a)(1), changes or alterations have been required in, or incorporated into, the project which avoid or substantially lessen the significant environmental effect as identified in the Final EIR.
- C. **Facts in Support of Finding.** Based on the analysis provided in Section 3.6 of the Final EIR, the project's potentially significant impact would be mitigated to below a level of significance with implementation of Mitigation Measures CR-1 and CR-2 of the Final EIR. Mitigation Measure CR-1 requires the area within 100 feet of Sites 2020-142-001, 2020-142-002, 2020-142-004, 2020-142-005, and 2020-142-008 to be designated Environmentally Sensitive Area (ESA) and fenced or flagged with exclusion markers to ensure avoidance. Mitigation Measure CR-2 requires all work to be halted within a 100-foot radius in the event cultural resources are discovered during construction. Work may not resume within the no-work radius until the Imperial County Planning and Development Services Department, through consultation as appropriate, determine that the site either: 1) is not an Historical Resource under CEQA or an Historic Property under Section 106; or 2) that the treatment measures have been completed to their satisfaction.

Mitigation Measure CR-1 - Environmentally Sensitive Area Fencing. Prior to issuance of grading permits and in coordination with a qualified archaeologist to be retained by the project applicant, the construction zone shall be narrowed or otherwise altered to avoid Sites 2020-142-001, 2020-142-002, 2020-142-004, 2020-142-005, and 2020-142-008. The area within 100 feet of Sites 2020-142-001, 2020-142-002, 2020-142-004, 2020-142-005, and 2020-142-008 shall be designated Environmentally Sensitive Area (ESA) and fenced or flagged with exclusion markers to ensure avoidance. Protective fencing shall not identify the protected area as a cultural resource area in order to discourage unauthorized disturbance or collection of artifacts. The ESA fencing or flags shall remain in place throughout project construction.

Mitigation Measure CR-2 - Evaluate Significance of Find (Unknown Cultural Resources). If subsurface deposits believed to be cultural in origin are discovered during construction, all work must halt within a 100-foot radius of the discovery. A qualified professional archaeologist who meets the Secretary of the Interior's

Standards for prehistoric and historic archaeology and is familiar with the resources of the region, shall be retained to evaluate the significance of the find, and shall have the authority to modify the no work radius as appropriate, using professional judgment. The following notifications shall apply, depending on the nature of the find:

- If the professional archaeologist determines that the find does not represent a cultural resource, work may resume immediately, and no agency notifications are required.
- If the professional archaeologist determines that the find does represent a cultural resource from any time period or cultural affiliation, he or she shall immediately notify the Imperial County Planning and Development Services Department. The Imperial County Planning and Development Services Department shall consult with the professional archaeologist on a finding of eligibility and implement appropriate treatment measures if the find is determined to be an Historical Resource under CEQA, as defined in Section 15064.5(a) of the CEQA Guidelines, or an Historic Property, as defined in 36 CFR 60.4. Work may not resume within the no-work radius until the Imperial County Planning and Development Services Department, through consultation as appropriate, determine that the site either: 1) is not an Historical Resource under CEQA or an Historic Property under Section 106; or 2) that the treatment measures have been completed to their satisfaction.

7.4.2 Archaeological Resources

- A. **Potential Impact.** The potential of finding a buried archaeological site during construction is considered low. However, like all construction projects in the state, the possibility exists. This potential impact is considered significant.
- B. **Finding.** Pursuant to CEQA Guidelines §15091 (a)(1), changes or alterations have been required in, or incorporated into, the project which avoid or substantially lessen the significant environmental effect as identified in the Final EIR.

Facts in Support of Finding. Based on the analysis provided in Section 3.6 of the Final EIR, the project's potentially significant impact would be mitigated to below a level of significance with implementation of Mitigation Measure CR-3. Mitigation Measure CR-3 requires the contractor to cease all work activities within approximately 100 feet of the discovery. In the event of an unanticipated discovery of archaeological materials during construction, the applicant shall retain the services of a qualified professional archaeologist to evaluate the significance of the materials prior to resuming any construction-related activities in the vicinity of the find. If the qualified archaeologist determines that the discovery constitutes a significant resource under CEQA and it cannot be avoided, the applicant shall implement an archaeological data recovery program.

Mitigation Measure CR-3 - Evaluate Significance of Find (Unknown Archaeological Resources). In the event of the discovery of previously unidentified archaeological materials, the contractor shall immediately cease all work activities within approximately 100 feet of the discovery. After cessation of excavation, the contractor shall immediately contact the Imperial County Department of Planning and Development Services Department. Except in the case of cultural items that fall within the scope of the Native American Grave Protection and Repatriation Act, the

discovery of any cultural resource within the project area shall not be grounds for a “stop work” notice or otherwise interfere with the project’s continuation except as set forth in this paragraph.

In the event of an unanticipated discovery of archaeological materials during construction, the applicant shall retain the services of a qualified professional archaeologist, meeting the Secretary of the Interior’s Standards for a Qualified Archaeologist, to evaluate the significance of the materials prior to resuming any construction-related activities in the vicinity of the find. If the qualified archaeologist determines that the discovery constitutes a significant resource under CEQA and it cannot be avoided, the applicant shall implement an archaeological data recovery program.

7.4.3 Human Remains

- A. **Potential Impact.** During the construction and operational phases of the proposed project, grading, excavation and trenching will be required. Although the potential for encountering subsurface human remains within the project site is low, there remains a possibility that human remains are present beneath the ground surface, and that such remains could be exposed during project construction. The potential to encounter human remains is considered a significant impact.
- B. **Finding.** Pursuant to CEQA Guidelines §15091 (a)(1), changes or alterations have been required in, or incorporated into, the project which avoid or substantially lessen the significant environmental effect as identified in the Final EIR.
- C. **Facts in Support of Finding.** Based on the analysis provided in Section 3.6 of the Final EIR, the project’s potential impact to human remains would be mitigated to below a level of significance with implementation of Mitigation Measure CR-4, provided below from the Final EIR. This measure requires that construction be halted in the area where the remains are found and the procedures set forth in California Health and Safety Code 7050.5, CEQA Section 15064.5, and California Public Resources Code Section 5097.98 (NPS 1983), as applicable.

Mitigation Measure CR-4 - Human Remains. If subsurface deposits believed to be human in origin are discovered during construction, all work must halt within a 100-foot radius of the discovery. A qualified professional archaeologist who meets the Secretary of the Interior’s Standards for prehistoric and historic archaeology and is familiar with the resources of the region, shall be retained to evaluate the significance of the find, and shall have the authority to modify the no work radius as appropriate, using professional judgment. The following notifications shall apply, depending on the nature of the find:

- If the find includes human remains, or remains that are potentially human, the professional archaeologist shall ensure reasonable protection measures are taken to protect the discovery from disturbance (AB 2641). The archaeologist shall notify the Imperial County Coroner (per § 7050.5 of the Health and Safety Code). The provisions of § 7050.5 of the California Health and Safety Code, § 5097.98 of the California PRC, and AB 2641 will be implemented.

- If the Coroner determines the remains are Native American and not the result of a crime scene, the Coroner will notify the NAHC, which then will designate a Native American Most Likely Descendant (MLD) for the project (§ 5097.98 of the PRC). The designated MLD will have 48 hours from the time access to the property is granted to make recommendations concerning treatment of the remains. If the landowner does not agree with the recommendations of the MLD, the NAHC may mediate (§ 5097.94 of the PRC). If no agreement is reached, the landowner must rebury the remains where they will not be further disturbed (§ 5097.98 of the PRC). This will also include either recording the site with the NAHC or the appropriate Information Center; using an open space or conservation zoning designation or easement; or recording a reinternment document with the county in which the property is located (AB 2641). Work may not resume within the no-work radius until the Imperial County Planning and Development Services Department, through consultation as appropriate, determine that the treatment measures have been completed to their satisfaction.

7.5 Geology and Soils

7.5.1 Seismic Ground Shaking

- Potential Impact.** Even with the integration of building standards, ground shaking within the project site could cause some structural damage to the facility structures or, at least, cause unsecured objects to fall. During a stronger seismic event, ground shaking could expose employees to injury from structural damage or collapse of electrical distribution facilities. Given the potentially hazardous nature of the project facilities, the potential impact of ground motion during an earthquake is considered a significant impact, as proposed structures, such as the substation and transmission lines could be damaged.
- Finding.** Pursuant to CEQA Guidelines §15091 (a)(1), changes or alterations have been required in, or incorporated into, the project which avoid or substantially lessen the significant environmental effect as identified in the Final EIR.
- Facts in Support of Finding.** Based on the analysis provided in Section 3.7 of the Final EIR, the project's potential impact would be mitigated to below a level of significance with implementation of Mitigation Measure GEO-1 of the Final EIR. This measure includes preparing geotechnical reports and implementing required measures.

Mitigation Measure GEO-1 - Prepare Geotechnical Report(s) as Part of Final Engineering for the Project and Implement Required Measures. Facility design for all project components shall comply with the site-specific design recommendations as provided by a licensed geotechnical or civil engineer to be retained by the project applicant. The final geotechnical and/or civil engineering report shall address and make recommendations on the following:

- Site preparation
- Soil bearing capacity

- Appropriate sources and types of fill
- Potential need for soil amendments
- Structural foundations
- Grading practices
- Soil corrosion of concrete and steel
- Erosion/winterization
- Seismic ground shaking
- Liquefaction
- Expansive/unstable soils

In addition to the recommendations for the conditions listed above, the geotechnical investigation shall include subsurface testing of soil and groundwater conditions, and shall determine appropriate foundation designs that are consistent with the version of the CBC that is applicable at the time building and grading permits are applied for. All recommendations contained in the final geotechnical engineering report shall be implemented by the project applicant. The final geotechnical and/or civil engineering report shall be submitted to Imperial County Public Works Department, Engineering Division for review and approval prior to issuance of building permits.

7.5.2 Liquefaction

- Potential Impact.** The project site has not been mapped for liquefaction potential by CGS (Appendix G of the Final EIR). However, given that the project site is underlain by sand and clay, there is a potential for liquefaction to occur on the project site. Additional geotechnical investigation would be required in order to assess the risk of liquefaction on the project site. The potential impact on liquefaction is considered a significant impact.
- Finding.** Pursuant to CEQA Guidelines §15091 (a)(1), changes or alterations have been required in, or incorporated into, the project which avoid or substantially lessen the significant environmental effect as identified in the Final EIR.
- Facts in Support of Finding.** Based on the analysis provided in Section 3.7 of the Final EIR, the project's potential impact would be mitigated to below a level of significance with implementation of Mitigation Measure GEO-1. This measure includes preparing geotechnical reports and implementing recommendations made by a licensed geotechnical engineer in compliance with the CBC prepared as part of a formal geotechnical investigation.

Mitigation Measure GEO-1 (as described above).

7.5.3 Construction Related Erosion

- Potential Impact.** During the site grading and construction phases, large areas of unvegetated soil would be exposed to erosive forces by water or wind for extended periods of time. Unvegetated soils are much more likely to erode from precipitation than vegetated areas because plants act to disperse, infiltrate, and retain water.

Construction activities involving soil disturbance, excavation, cutting/filling, stockpiling, and grading activities could result in increased erosion and sedimentation to surface waters. Construction could produce sediment-laden stormwater runoff (nonpoint source pollution), a major contributor to the degradation of water quality. If precautions are not taken to contain contaminants, construction-related erosion impacts are considered significant.

- B. **Finding.** Pursuant to CEQA Guidelines §15091 (a)(1), changes or alterations have been required in, or incorporated into, the project which avoid or substantially lessen the significant environmental effect as identified in the Final EIR.
- C. **Facts in Support of Finding.** Based on the analysis provided in Section 3.7 of the Final EIR, the project's potential impact would be mitigated to below a level of significance with implementation of Mitigation Measure GEO-1, and Mitigation Measure HYD-1 of the Final EIR (refer to Final EIR Section 3.10 Hydrology/Water Quality). Mitigation Measure HYD-1 requires that soil stabilization and erosion control practices (e.g., hydroseeding, erosion control blankets, mulching) are implemented during the construction phase.

7.5.4 Unstable Geologic Unit or Soil

- A. **Potential Impact.** The potential for lateral spreading to occur on the project site has not yet been determined. Additional geotechnical investigation would be required in order to assess the risk of lateral spreading to occur on the project site. The potential impact associated with lateral spreading is considered a significant impact.

As described above, given that the project site is underlain by sand and clay, there is potential for liquefaction to occur on the project site. Additional geotechnical investigation would be required in order to assess the risk of liquefaction on the project site. The potential impact on liquefaction is considered a significant impact.

It is unknown whether collapsible soils are present on the project site. Additional geotechnical investigation would be required in order to assess the risk of collapsible soils to occur on the project site. The potential impact associated with collapsible soils is considered a significant impact.

- B. **Finding.** Pursuant to CEQA Guidelines §15091 (a)(1), changes or alterations have been required in, or incorporated into, the project which avoid or substantially lessen the significant environmental effect as identified in the Final EIR.
- C. **Facts in Support of Finding.** Based on the analysis provided in Section 3.7 of the Final EIR, the project's potential impacts would be mitigated to below a level of significance with implementation of Mitigation Measure GEO-1. This measure includes preparing geotechnical reports and implementing recommendations made by a licensed geotechnical engineer in compliance with the CBC prepared as part of a formal geotechnical investigation.

Mitigation Measure GEO-1 (as described above).

7.5.5 Expansive or Corrosive Soils

- A. **Potential Impact.** The project site is underlain by sand, gravelly sand and clay/silty clay. Generally, sands are not considered expansive soils. However, clays may exhibit moderate to high expansion potential due to variation in moisture content. Unless properly mitigated, shrink-swell soils could exert additional pressure on buried structures and electrical connections producing shrinkage cracks that could allow water infiltration and compromise the integrity of backfill material. These conditions could be worsened if structural facilities are constructed directly on expansive soil materials. This potential impact would be significant as structures could be damaged by these types of soils. In addition, corrosive soils can damage underground utilities including pipelines and cables, or weaken roadway structures. This potential impact would be significant as structures could be damaged by these types of soils.
- B. **Finding.** Pursuant to CEQA Guidelines §15091 (a)(1), changes or alterations have been required in, or incorporated into, the project which avoid or substantially lessen the significant environmental effect as identified in the Final EIR.
- C. **Facts in Support of Finding.** Based on the analysis provided in Section 3.7 of the Final EIR, the project's potential impact would be mitigated to below a level of significance with implementation of Mitigation Measure GEO-1. A site-specific geotechnical investigation would be required at the project site to determine the extent and effect of problematic soils which have been identified during preliminary laboratory screenings of near surface on-site soils. Implementation of Mitigation Measure GEO-1, which requires the preparation of a design-level geotechnical report, would reduce potential impacts associated with expansive and corrosive soils to a level less than significant.

Mitigation Measure GEO-1 (as described above).

7.5.6 Paleontological Resources

- A. **Potential Impact.** The project site is in the Salton Basin near the shoreline of ancient Lake Cahuilla. The lake covered much of the Imperial Valley and created an extensive lacustrine environment. Lake Cahuilla experienced several fill recession episodes before it finally dried up about 300 years ago. In 1905, the Colorado River overflowed into the Salton Basin creating the present-day Salton Sea. As previously mentioned above, the project site is generally underlain by deposits from periodic flooding of the Colorado River and Lake Cahuilla. Therefore, the project site is considered to be paleontologically sensitive. Project construction has the potential to unearth and/or potentially destroy previously undiscovered paleontological resources.
- B. **Finding.** Pursuant to CEQA Guidelines §15091 (a)(1), changes or alterations have been required in, or incorporated into, the project which avoid or substantially lessen the significant environmental effect as identified in the Final EIR.
- C. **Facts in Support of Finding.** Based on the analysis provided in Section 3.7 of the Final EIR, Mitigation Measures GEO-2 would reduce the potential impact on paleontological resources to a level less than significant. Mitigation Measure GEO-2 would require that in the event where paleontological resources are discovered, construction shall be halted within 50 feet of any paleontological finds and shall not

resume until a Qualified Paleontologist can determine the significance of the find and/or the find has been fully investigated, documented, and cleared.

Mitigation Measure GEO-2 Paleontological Resources. In the event that unanticipated paleontological resources or unique geologic resources are encountered during ground-disturbing activities, work must cease within 50 feet of the discovery and a paleontologist shall be hired to assess the scientific significance of the find. The consulting paleontologist shall have knowledge of local paleontology and the minimum levels of experience and expertise as defined by the *Society of Vertebrate Paleontology's Standard Procedures (2010) for the Assessment and Mitigation of Adverse Impacts to Paleontological Resources*. If any paleontological resources or unique geologic features are found within the project site, the consulting paleontologist shall prepare a paleontological Treatment and Monitoring Plan to include the methods that will be used to protect paleontological resources that may exist within the project site, as well as procedures for monitoring, fossil preparation and identification, curation of specimens into an accredited repository, and preparation of a report at the conclusion of the monitoring program.

7.6 Hydrology and Water Quality

7.6.1 Violation of Water Quality Standards during Construction

- A. **Potential Impact.** During the construction phase, sedimentation and erosion can occur because of tracking from earthmoving equipment, erosion and subsequent runoff of soil, and improperly designed stockpiles. In addition to erosion and sedimentation, many different types of hazardous compounds will be used during the construction phase, with proper application, management, and containment being of high importance. Poorly managed construction materials can lead to the possibility for exposure of potential contaminants to precipitation. When this occurs, these visible and/or non-visible constituents become entrained in storm water runoff. This is considered a potentially significant impact.
- B. **Finding.** Pursuant to CEQA Guidelines §15091 (a)(1), changes or alterations have been required in, or incorporated into, the project which avoid or substantially lessen the significant environmental effect as identified in the Final EIR.
- C. **Facts in Support of Finding.** Based on the analysis provided in Section 3.10 of the Final EIR, the project's potentially significant impact would be mitigated to below a level of significance with implementation of Mitigation Measures HYD-1 of the Final EIR. Prior to construction and grading activities, the project applicant is required to file a Notice of Intent (NOI) with the State Water Resources Control Board to comply with the General National Pollution Discharge Elimination System (NPDES) Construction Permit and prepare a Stormwater Pollution Prevention Plan (SWPPP), which addresses the measures that would be included during construction or the project to minimize and control construction and post-construction runoff to the maximum extent practicable. In addition, NPDES permits require the implementation of BMPs that achieve a level of pollution control to the maximum extent practical. With the implementation of Mitigation Measure HYD-1, impacts on surface water quality as attributable to the project would be reduced to a less than significant level through the

inclusion of focused BMPs for the protection of surface water resources. Monitoring and contingency response measures would be included to verify compliance with water quality objectives for all surface waters crossed during construction. In addition, given that site decommissioning would result in similar activities as identified for construction, these impacts could also occur in the future during site restoration activities.

Mitigation Measure HYD-1 - Prepare SWPPP and Implement BMPs Prior to Construction and Site Restoration. The project applicant or its contractor shall prepare a SWPPP specific to the project and be responsible for securing coverage under SWRCB's NPDES stormwater permit for general construction activity (Order 2009-0009-DWQ). The SWPPP shall identify specific actions and BMPs relating to the prevention of stormwater pollution from project-related construction sources by identifying a practical sequence for site restoration, BMP implementation, contingency measures, responsible parties, and agency contacts. The SWPPP shall reflect localized surface hydrological conditions and shall be reviewed and approved by the appropriate agency prior to commencement of work and shall be made conditions of the contract with the contractor selected to build and decommission the project. The SWPPP shall incorporate control measures in the following categories:

- Soil stabilization and erosion control practices (e.g., hydroseeding, erosion control blankets, mulching)
- Sediment control practices (e.g., temporary sediment basins, fiber rolls)
- Temporary and post-construction on- and off-site runoff controls
- Special considerations and BMPs for water crossings and drainages
- Monitoring protocols for discharge(s) and receiving waters, with emphasis place on the following water quality objectives: dissolved oxygen, floating material, oil and grease, potential of hydrogen (pH), and turbidity
- Waste management, handling, and disposal control practices
- Corrective action and spill contingency measures
- Agency and responsible party contact information
- Training procedures that shall be used to ensure that workers are aware of permit requirements and proper installation methods for BMPs specified in the SWPPP

The SWPPP shall be prepared by a Qualified SWPPP Practitioner and/or Qualified SWPPP Developer with BMPs selected to achieve maximum pollutant removal and that represent the best available technology that is economically achievable. Emphasis for BMPs shall be placed on controlling discharges of oxygen-depleting substances, floating material, oil and grease, acidic or caustic substances or compounds, and turbidity. BMPs for soil stabilization and erosion control practices and sediment control practices will also be required. Performance and effectiveness of these BMPs shall be determined either by visual means where applicable (i.e., observation of above-normal sediment release), or by actual water sampling in cases where verification of contaminant reduction or elimination, (inadvertent petroleum release) is required to determine adequacy of the measure.

7.6.2 Violation of Water Quality Standards during Operation

- A. **Potential Impact.** As runoff flows over developed surfaces, water can entrain a variety of potential pollutants including, but not limited to, oil and grease, pesticides, trace metals, and nutrients. These pollutants can become suspended in runoff and carried to receiving waters. These effects are commonly referred to as non-point source water quality impacts.

Long-term operation of the solar facility poses a limited threat to surface water quality after the completion of construction. The project would be subject to the County's Grading Regulations as specified in Section 91010.02 of the Ordinance Code. However, since the project site is located in unincorporated Imperial County and not subject to a Municipal Separate Storm Sewer System or NPDES General Industrial Permit, there is no regulatory mechanism in place to address post-construction water quality concerns. Based on this consideration, the project has the potential to result in both direct and indirect water quality impacts that could be significant.

- B. **Finding.** Pursuant to CEQA Guidelines §15091 (a)(1), changes or alterations have been required in, or incorporated into, the project which avoid or substantially lessen the significant environmental effect as identified in the Final EIR.
- C. **Facts in Support of Findings.** Based on the analysis provided in Section 3.10 of the Final EIR, the project's potentially significant impact would be mitigated to below a level of significance with implementation of Mitigation Measure HYD-2 of the Final EIR. Mitigation Measure HYD-2 requires the project to incorporate post-construction source control and treatment control BMPs into the project's final drainage plan.

Mitigation Measure HYD-2 - Incorporate Post-Construction Runoff, Source Control, and Treatment Control BMPs into Final Project Drainage Plan. The project's Final Drainage Plan shall adhere to the County's Engineering Guidelines Manual, IID "Draft" Hydrology Manual, or other recognized source with approval by the County Engineer to control and manage the on- and off-site discharge of stormwater to existing drainage systems. The Final Drainage Plan shall provide both short- and long-term drainage solutions to ensure the proper sequencing of drainage facilities, and shall include source control and treatment BMPs to adequately treat collected runoff prior to discharge, as necessary.

8 Cumulative Impacts

As analyzed in Chapter 5 of the Final EIR, cumulative impacts to agricultural resources, air quality, biological resources, cultural resources, geology and soils, and hydrology/water quality would be significant prior to implementation of project specific mitigation measures, and mitigation that would be required of other cumulative projects.

Agricultural Resources

As discussed in Section 3.3, Agricultural Resources, the project does not contain Prime Farmland, Farmland of Statewide Importance, or Unique Farmland. Therefore, the proposed project would not convert land designated as Prime Farmland, Farmland of Statewide Importance, or Unique Farmland to non-agricultural uses or incrementally add to the conversion of agricultural land in Imperial County

on a temporary or permanent basis. Furthermore, the project site is located within the Renewable Energy Zone and is, therefore, considered an appropriate use in this area. Additionally, as a condition of project approval (CUP condition), the project applicant or its successor in interest will be responsible for implementing a reclamation plan when the project is decommissioned at the end of its lifespan.

A portion of the project site is designated as Farmland of Local Importance. It should be noted that analysis of Other Land and Farmland of Local Importance is not required under CEQA significance criteria, as these designations are not considered an "agricultural land" per CEQA Statute Section 21060.1(a). However, in terms of preservation of agricultural land Mitigation Measure AG-1 would be implemented to reduce potential impacts related to pests to a less than significant level. Each individual cumulative project would be or would have been required to provide mitigation for any impacts on agricultural resources in accordance with the County's policies directed at mitigating the impact associated with the conversion of important farmlands. Therefore, the project's contribution to this impact would be less than cumulatively considerable.

Air Quality

Construction. The proposed project would generate air emissions due to vehicle and dust emissions associated with construction activities. Similar effects would also be realized upon site decommissioning, which would be carried out in conjunction with the project's restoration plan, and subject to applicable ICAPCD standards. Likewise, the other cumulative projects identified in Final EIR Table 5-1 would result in the generation of air emissions during construction activities.

With respect to the proposed project, during the construction and decommissioning phases, the project would generate ROG, NO_x, CO, SO₂, PM₁₀, and PM_{2.5} emissions during each active day of construction. As discussed in Section 3.4, Air Quality, the project's daily construction emissions would not exceed the ICAPCD thresholds for ROG, NO_x, CO, SO₂, and PM_{2.5}. However, the project would exceed the ICAPCD threshold for PM₁₀ and represents a significant air quality impact. The project's impact could be cumulatively considerable because the Imperial County portion of the SSAB are nonattainment already for O₃ and PM₁₀ under state standards and for O₃ and PM_{2.5} federal standards. Thus, existing O₃ and PM₁₀ levels in the SSAB are at unhealthy levels during certain periods. Additionally, the cumulative construction effects could again be experienced in the future during decommissioning and site restoration activities.

Several of the projects listed in Final EIR Table 5-1 are already constructed and in operation. Furthermore, the remaining cumulative projects, with exception of the Vikings Solar, Iris Cluster – Lyons, and Centinela Solar Projects, are currently under construction and not anticipated to involve overlapping construction activities with the proposed project. In the event the proposed project is constructed in conjunction with the Vikings Solar Project (pending entitlement), Iris Cluster – Lyons (approved but not built), and Centinela Solar Project (approved but not built), each project would be subject to mitigation pursuant to ICAPCD's Regulations. Therefore, the cumulative impact would be reduced to a level less than significant through compliance with these measures. Further, because the proposed project will be required to implement measures consistent with ICAPCD regulations designed to alleviate the cumulative impact associated with fugitive dust (PM₁₀) and NO_x, the project's contribution would be rendered less than cumulatively considerable and is therefore, less than significant.

Operation. As the proposed project would have no major stationary emission sources and would require minimal vehicular trips, operation of the proposed solar facility would result in substantially lower emissions than project construction. The project's operational emissions would not exceed the

Tier I thresholds; therefore, the impact would be less than significant. Operational impacts of other renewable energy facilities identified in Final EIR Table 5-1 would also be similar. Although these cumulative projects generally involve large areas, their operational requirements are very minimal, requiring minimal staff or use of machinery or equipment that generate emissions. Further, alternative energy projects, such as the project, would assist attainment of regional air quality standards and improvement of regional air quality by providing clean, renewable energy sources. Consequently, the projects would provide a positive contribution to the implementation of applicable air quality plan policies and compliance with EO S-3-05.

However, from a cumulative air quality standpoint, the potential cumulative impact associated with the generation of O₃, PM_{2.5} and PM₁₀ emissions during operation of the cumulative projects is a consideration because existing O₃ and PM₁₀ levels in the SSAB are at unhealthy levels during certain periods. Imperial County is classified as non-attainment for PM_{2.5} for the urban areas of Imperial County. However, the project's operational contribution to O₃, PM_{2.5} and PM₁₀ would be below a level of significance. As with the construction phases, the cumulative projects would be required to comply with ICAPCD's Regulation VIII for dust control (Regulation VIII applies to both the construction and operational phases of projects). As a result, the ICAPCD would be required to comply with the various dust control measures and to prepare and implement operational dust control plans as approved by the ICAPCD, which is a component of ICAPCD's overall framework of the AQAP that sets forth a comprehensive program for SSAB's compliance with all federal and state air quality standards. Therefore, the project would not contribute to long-term cumulatively considerable air quality impacts and the project would not result in cumulatively significant air quality impacts, and cumulative impacts would be less than significant.

Biological Resources

The geographic scope for considering cumulative impacts on biological resources includes the Imperial Valley and related biological habitats. Final EIR Table 5-1 lists the projects considered for the biological resources cumulative impact analysis.

In general terms, in instances where a potential impact could occur, CDFW and USFWS have promulgated a regulatory scheme that limits impacts on these species. The effects of the project would be rendered less than significant through implementation of Mitigation Measures BIO-1 to BIO-7 (Section 3.5, Biological Resources) which require compliance with all applicable regulations that protect plant, fish, and animal species. Other cumulative projects would also be required to avoid impacts on special-status species and/or mitigate to the satisfaction of the CDFW and USFWS for the potential loss of habitat. As described in Section 3.5, Biological Resources, the project has the potential to result in impacts on biological resources. These impacts are generally focused on potential construction-related effects to special-status plant species and wildlife.

The proposed project has been designed to avoid impacts to the riparian habitat, disturbed riparian habitat, and tamarisk thickets (CDFW sensitive natural community) within the project site. However, 14 special-status plant species that have the potential to occur within the project site. 11 of these plant species have a low potential to occur due to limited suitable habitat. Due to the presence of suitable habitat and several known recent occurrences within five miles of the project site, the following species were determined to have moderate potential to occur: Abram's spurge (CRPR 2B.2), Wiggins' croton (CRPR 2B.2), and sand food (CRPR 1B.2). Implementation of Mitigation Measures BIO-1, BIO-2, and BIO-3 would reduce project impacts to a level less than significant.

Burrowing Owls are protected by the CDFW mitigation guidelines for burrowing owl (CDFW 2012) and Consortium guidance (1993), which require a suite of mitigation measures to ensure direct effects to burrowing owls during construction activities are avoided and indirect effects through burrow destruction and loss of foraging habitat are mitigated at prescribed ratios. Additionally, as provided in Section 3.5, Biological Resources, special-status bird species have a potential to be present. In addition, several common bird species could nest on the project site. As a result of project-related construction activities, one or more of these protected species could be harmed. However, with the implementation of Mitigation Measures BIO-2 through BIO-7, as identified in Section 3.5, Biological Resources, these impacts would be reduced to a level of less than significant.

As with the proposed project, the cumulative projects within the geographic scope of the project would be required to comply with the legal framework and provide mitigation for impacts on biological resources as described above. Based on these considerations, impacts on biological resources would not be cumulatively considerable.

The analysis below is conducted qualitatively and in the context that the cumulative projects would be subject to a variety of statutes and administrative frameworks that require mitigation for impacts on biological resources.

Birds listed at 50 CFR 10.3 are protected by the MBTA (16 USC 703 et seq.), a Federal statute that implements treaties with several countries on the conservation and protection of Birds listed at 50 CFR 10.3 are protected by the MBTA (16 USC 703 et seq.), a Federal statute that implements treaties with several countries on the conservation and protection of migratory birds. The MBTA is enforced by USFWS. This act prohibits the killing of any migratory birds without a valid permit. Any activity which contributes to unnatural migratory bird mortality could be prosecuted under this act. With few exceptions, most birds are considered migratory under this act. Raptors and active raptor nests are protected under California FGCs 3503.5, 3503, and 3513.

The CWA and California's Porter-Cologne Water Quality Control Act provide protection for water-related biological resources by controlling pollution, setting water quality standards, and preventing jurisdictional streams, lakes, and rivers from being filled without a federal permit. Freshwater forested/shrub wetland are present within the project site. Additionally, perennial and ephemeral drainage features are also present and convey flows in the wetlands within and around the All-American Canal. As such, these drainage features would likely be considered federally and state jurisdictional. However, the proposed project has been designed to avoid impacts to aquatic resources. As shown on the Site Plan (Figure 2-3), project components would not be sited on the project site where aquatic resources are present. Therefore, implementation of the project would result in no impact on state or federally protected aquatic resources.

The proposed project would comply with these and other laws, regulations and guidelines and therefore would not contribute substantially to a cumulative biological resources impact. Similarly, the cumulative projects within the geographic scope of the proposed project will be required to comply with the legal frameworks set forth above, as well as others, and will be required to mitigate their impacts to a less than significant level. Therefore, the project would not contribute to a cumulatively considerable impact to biological resources, and cumulative impacts would be less than significant.

Cultural Resources

As discussed in Section 3.6, Cultural Resources, five cultural resources are being treated as eligible for listing in the CRHR as historical resources. However, the project has been designed to avoid all five historical resources and Mitigation Measure CR-1 will be implemented to ensure the sites are

avoided during construction. Mitigation Measure CR-1 requires the installation of orange environmentally sensitive area fencing or flagging around the boundaries of each of the resources prior to any construction activity and shall remain in place throughout project construction. Further, in the event that unknown cultural resources are discovered during project construction, significant impacts could occur. Therefore, Mitigation Measure CR-2 would be implemented to reduce potential impacts to previously unrecorded cultural resources to a level less than significant.

The potential of finding a buried archaeological site during construction is considered low. However, like all construction projects in the state, the possibility exists. This potential impact is considered significant. Implementation of Mitigation Measure CR-3 would reduce potential impacts associated with the unanticipated discovery of unknown buried archaeological resources. Additionally, implementation of Mitigation Measure CR-4 would reduce potential impacts on human remains to a level less than significant.

Future projects with potentially significant impacts on cultural resources would be required to comply with federal, state, and local regulations and ordinances protecting cultural resources through implementation of similar project-specific mitigation measures during construction. Therefore, through compliance with regulatory requirements, standard conditions of approval, and Mitigation Measures CR-1 through CR-4, the proposed project would have a less than cumulatively considerable contribution to impacts on cultural resources.

During operations and decommissioning of the project, no additional impacts on archeological resources would be anticipated because the soil disturbance would have already occurred and been mitigated during construction.

Geology and Soils

The Imperial Valley portion of the Salton Trough physiographic province of Southern California is used as the geographic scope for the analysis of cumulative impacts on geology/soils and mineral resources. Cumulative development would result in an increase in population and development that could be exposed to hazardous geological conditions, depending on the location of proposed developments. Geologic and soil conditions are typically site specific and can be addressed through appropriate engineering practices. Cumulative impacts on geologic resources would be considered significant if the project would be impacted by geologic hazard(s) and if the impact could combine with off-site geologic hazards to be cumulatively considerable. None of the projects identified within the geographic scope of potential cumulative impacts would intersect or be compounded with the project's site-specific geology and soils impacts which would be addressed by a site-specific geotechnical report per Mitigation Measure GEO-1. Therefore, no cumulatively considerable effects are identified for geology/soils, and cumulative impacts would be less than significant.

Development of the proposed project, in combination with other projects in the area, has the potential to contribute to a cumulatively significant paleontological resources impact due to the potential loss of paleontological resources unique to the region. However, mitigation is included in this EIR to reduce potentially significant project impacts to paleontological resources during construction of the proposed project. Implementation of Mitigation Measure GEO-2 would ensure that the potential impacts on paleontological resources do not rise to the level of significance. Future projects with potentially significant impacts on paleontological resources would be required to comply with federal, state, and local regulations and ordinances protecting paleontological resources through implementation of similar project-specific mitigation measures during construction. Therefore, through compliance with regulatory requirements, standard conditions of approval, and Mitigation Measure GEO-2, the

proposed project would have a less than cumulatively considerable contribution to impacts on paleontological resources.

Hydrology/Water Quality

Final EIR Table 5-1 lists the projects considered for the hydrology and water quality cumulative impact analysis. The geographic scope for considering cumulative hydrology and water quality impacts is the Imperial Valley Hydrologic Unit as defined by the Colorado Basin RWQCB Basin Plan.

The construction of the project is expected to result in short-term water quality impacts. Compliance with the SWRCB's NPDES general permit for activities associated with construction (2009-0009-DWQ) per Mitigation Measure HYD-1 would reduce water quality impacts. As with the project, future cumulative projects would be required to comply with the Construction General Permit. The SWRCB has determined that the Construction General Permit protects water quality, is consistent with the CWA, and addresses the cumulative impacts of numerous construction activities throughout the state. This determination in conjunction with the implementation of mitigation would ensure short-term water quality impacts are not cumulatively considerable.

The project is not expected to result in long-term operations-related impacts related to water quality. The project would mitigate potential water quality impacts by preparing a drainage plan that would implement site design, source control, and treatment control BMPs per Mitigation Measure HYD-2. Future cumulative projects may also be required to comply with the SWRCB's NPDES general permit for industrial activities, as well as rules found in the CWA, Section 402(p)(1) and 40 CFR 122.26, and implemented Order No. 90-42 of the RWQCB. With implementation of SWRCB, Colorado River RWQCB, and County policies, plans, and ordinances governing land use activities that may degrade or contribute to the violation of water quality standards, cumulatively considerable impacts on water quality would be minimized to a less than significant level.

Based on a review of the FEMA Flood Insurance Rate Map FIRM, the proposed solar energy facility, gen-tie line, and access roads located on the western portion of the project site are located in Zone X (unshaded). The FEMA Zone X (unshaded) designation is an area determined to be outside the 0.2 percent annual chance floodplain. As such, the project would not result in a significant cumulatively considerable impact on floodplains by constructing new facilities within an identified flood hazard zone.

Based on these considerations, the project would not contribute to or result in a significant cumulatively considerable impact to hydrology or water quality, and cumulative impacts would be less than significant.

9 Effects Found Not to Be Significant

CEQA Guidelines §15128 require that an EIR contain a brief statement disclosing the reasons why various possible significant effects of the project were found not to be significant, and therefore would not be discussed in detail in the EIR. Final EIR Chapter 6 identifies the following issues areas that will not be impacted by the project: Forestry Resources, Energy, Mineral Resources, Population and Housing, Public Services, Recreation, Utilities and Service Systems (wastewater, stormwater, power, natural gas, and telecommunications, and solid waste), and Wildfire.

10 Findings Regarding Feasible Alternatives

Pursuant to CEQA Guidelines §15126.6(a), EIRs must “describe a range of reasonable alternatives to the project, or to the location of this project, which would feasibly attain most of the basic objectives of the project but would avoid or substantially lessen any of the significant effects of the project, and evaluate the comparative merits of the alternatives.”

CEQA establishes no categorical legal imperative as to the scope of alternatives to be analyzed in an EIR. To be legally sufficient, the consideration of project alternatives in an EIR must permit informed agency decision-making and informed public participation. The analysis of alternatives is evaluated against a rule of reason. Alternatives are suitable for study in an EIR if they meet all of the following thresholds: (1) substantially reduce or avoid the project’s significant environmental impacts; (2) attain most of the basic project objectives; (3) are potentially feasible; and (4) are reasonable and realistic. (Guidelines §15126.6, Subds. (a), (c).) Candidate alternatives that do not satisfy these requirements may be excluded from further analysis. An EIR need not consider alternatives that would change the fundamental nature of the project or that cannot achieve the fundamental goals and purposes of the proposed project.

The alternatives to the project are evaluated in Section 7 of the EIR in terms of their ability to meet the basic objectives of the project, and eliminate or further reduce its significant environmental effects. Based on these parameters, the following alternatives were considered and analyzed in the EIR:

- (1) Alternative 1–No Project/No Development Alternative
- (2) Alternative 2–Reduced Project Site

10.1 Alternative 1 – No Project/No Development

The State CEQA Guidelines require analysis of the No Project Alternative. According to §15126.6(e)(1) “[t]he specific alternative of ‘no project’ shall also be evaluated along with its impact.” Additionally, according to CEQA Guidelines §15126.6(3)(2), the ‘no project’ analysis shall discuss the existing conditions at the time the notice of preparation is published, or if no notice of preparation is published, at the time environmental analysis is commenced, as well as what would be reasonably expected to occur in the foreseeable future if the project were not approved, based on the current plans and consistent with available infrastructure and community services.

Because the solar energy facility would not be constructed on the proposed project site, the Alternative 1-No Project/No Development Alternative would avoid the project impacts associated with agricultural resources; air quality; biological resources; cultural resources; geology and soils; and hydrology and water quality.

- A. **Finding.** Alternative 1 is infeasible. It is found pursuant to Public Resources Code Section 21081(a)(3), that specific economic, legal, social, technological, or other considerations, make Alternative 1 infeasible.
- B. **Facts in Support of Findings.** Alternative 1- No Project/No Development Alternative is rejected as infeasible because it will not meet the primary objectives of the proposed project which include:
 - Construct and operate a solar energy facility capable of producing up to 100 MW AC of electricity to assist the State of California in achieving its 60 percent renewable portfolio standard by 2030.

- Provide a 100 MW BESS system, that would accommodate and store the power generated by the project so that the facility can continue to provide renewable energy during non-daylight hours.
- Interconnect directly to IID's existing electrical transmission system.
- Help California meet its statutory and regulatory goal of increasing renewable power generation, including greenhouse gas reduction goals of Senate Bill 32.

Additionally, the No Project/No Development Alternative would not help California meet its statutory and regulatory goal of increasing renewable power generation, including GHG reduction goals of SB 32.

For the reasons stated above, the County finds that this alternative is infeasible and less desirable than the proposed project and rejects this alternative.

10.2 Alternative 2 – Reduced Project Site

The purpose of this alternative is to reduce the size of the project site to minimize impacts on biological resources by increasing the setback of the project from sensitive vegetation communities and aquatic resources. Tamarisk thickets, identified by CDFW as a sensitive natural community, have been mapped on the northern parcel (APN 059-300-015) of the project site. Freshwater forested/shrub wetland, riparian habitat, and disturbed riparian habitat have also been mapped on the northern parcel of the project site. This alternative would remove the northern parcel (APN 059-300-015), thereby reducing the project site by 301 acres from 450 acres to 149 acres.

This alternative would meet most of the basic objectives of the proposed project.

- Finding.** It is found pursuant to Public Resources Code Section 21081(a)(3), that specific economic, legal, social, technological, or other considerations, make Alternative 2 infeasible.
- Facts in Support of Findings.** The purpose of studying alternatives to the proposed project is to identify alternatives that would substantially reduce or avoid the significant environmental impacts of the proposed project. This alternative would reduce impacts to agricultural resources, air quality, biological resources, cultural resources, hydrology/water quality, and utilities/service systems compared to the proposed project.

However, this alternative would make it more difficult to achieve the overall objective of providing a total of 100 MW of renewable solar energy, as there would be less area available for the placement of PV structures.

For the reasons stated above, the County finds that this alternative is infeasible and less desirable than the proposed project and rejects this alternative.

10.3 Findings Regarding Range of Alternatives

- Finding.** The EIR considers a reasonable range of alternatives. Substantial evidence supports the conclusion of the EIR regarding alternatives considered and rejected.
- Facts in Support of Findings.** The purpose of studying alternatives to the proposed project is to identify alternatives that would substantially reduce or avoid the significant environmental impacts of the proposed project. Substantial evidence shows that all potentially significant environmental impacts of the proposed project are mitigated below significant levels and that

no significant unavoidable significant environmental impacts remain. Consequently, the range of alternatives studied in the EIR is reasonable because it included two alternatives to the proposed project despite there being no significant unavoidable environmental impacts necessitating consideration of alternatives to substantially reduce or avoid such impacts. Although some alternatives would reduce the less-than-significant impacts of the proposed project, CEQA does not require that such alternatives be adopted.

Findings Regarding Growth Inducing Impacts

The proposed project is located within the unincorporated area of Imperial County, and it does not involve the development of permanent residences that would directly result in population growth in the area. The unemployment rate in Imperial County, as of September 2022, was 16.0 percent (State of California Employment Development Department 2022). The applicant expects to utilize construction workers from the local and regional area, a workforce similar to that involved in the development of other utility-scale solar facilities. Based on the unemployment rate, and the availability of the local workforce, construction of the proposed project would not have a growth-inducing effect related to workers moving into the area and increasing the demand for housing and services.

Once construction is completed, the facility would be remotely operated, controlled and monitored and with no requirement for daily on-site employees. Security personnel may conduct unscheduled security rounds and would be dispatched to the project site in response to a fence breach or other alarm. It is anticipated that maintenance of the facilities would require minimal site presence to perform periodic visual inspections and minor repairs. On intermittent occasions, the presence of additional workers may be required for repairs or replacement of equipment and panel cleaning; however, because of the nature of the facility, such actions would likely occur infrequently. Overall, minimal maintenance requirements are anticipated. The proposed project would not result in substantial population growth, as the number of employees required to operate and maintain the facility is minimal.

While the proposed project would contribute to energy supply, which indirectly supports population growth, the proposed project is a response to the state's need for renewable energy to meet its Renewable Portfolio Standard, and while it would increase the availability of renewable energy, it would also replace existing sources of non-renewable energy. Unlike a gas-fired power plant, the proposed project is not being developed as a source of base-load power in response to growth in demand for electricity. The power generated would be added to the state's electricity grid with the intent that it would displace fossil fueled power plants and their associated environmental impacts, consistent with the findings and declarations in SB 100 that a benefit of the Renewable Portfolio Standard is displacing fossil fuel consumption within the state. The project is being proposed in response to state policy and legislation promoting development of renewable energy.

The proposed project would supply energy to accommodate and support existing demand and projected growth, but the energy provided by the project would not foster any new growth because (1) the additional energy would be used to ease the burdens of meeting existing statewide energy demands within and beyond the area of the project site; (2) the energy would be used to support already-projected growth; or, (3) the factors affecting growth are so diverse that any potential connection between additional energy production and growth would necessarily be too speculative and uncertain to merit further analysis.

Under CEQA, an EIR should consider potentially significant energy implications of a project (CEQA Guidelines Appendix F(II); PRC Section 21100(b)(3)). However, the relationship between the proposed project's increased electrical capacity and the growth-inducing impacts outside the

surrounding area is too speculative and uncertain to warrant further analysis. When a project's growth-inducing impacts are speculative, the lead agency should consider 14 CCR §15145, which provides that, if an impact is too speculative for evaluation, the agency should note this conclusion and terminate discussion of the impact. As the court explained in *Napa Citizens for Honest Gov't v. Napa County Board of Supervisors*, 91 Cal. App.4th 342, 368: "Nothing in the Guidelines, or in the cases, requires more than a general analysis of projected growth" *Napa Citizens*, 91 CA4th at 369. The problem of uncertainty of the proposed project's growth-inducing effects cannot be resolved by collection of further data because of the diversity of factors affecting growth.

While the EIR has considered that the proposed project, as an energy project, might foster regional growth, the particular growth that could be attributed to the proposed project is unpredictable, given the multitude of variables at play, including uncertainty about the nature, extent, and location of growth and the effect of other contributors to growth besides the proposed project. No accurate and reliable data is available that could be used to predict the amount of growth outside the area that would result from the proposed project's contribution of additional electrical capacity. The County of Imperial has not adopted a threshold of significance for determining when an energy project is growth-inducing. Further evaluation of this impact is not required under CEQA.

Additionally, the project would not involve the development of any new roadways, new water systems, or sewer; and thus, the project would not further facilitate additional development into outlying areas. For these reasons, the proposed project would not be growth-inducing.

Findings Regarding Significant Irreversible Environmental Changes

Energy resources needed for the construction of the proposed project would contribute to the incremental depletion of renewable and non-renewable resources. Resources, such as timber, used in building construction are generally considered renewable and would ultimately be replenished. Non-renewable resources, such as petrochemical construction materials, steel, copper, lead and other metals, gravel, concrete, and other materials, are typically considered finite and would not be replenished over the lifetime of the project. Thus, the project would irretrievably commit resources over the anticipated 30-year life of the project.

At the end of the project's operation term, the applicant may determine that the project should be decommissioned and deconstructed. Should the project be decommissioned, the project applicant is required to restore land to its pre-project state. Consequently, some of the resources on the site could potentially be retrieved after the site has been decommissioned. Concrete footings, foundations, and pads would be removed and recycled at an off-site location. All remaining components would be removed, and all disturbed areas would be reclaimed and recontoured. The applicant anticipates using the best available recycling measures at the time of decommissioning.

Implementation and operation of the proposed project would promote the use of renewable energy and contribute incrementally to the reduction in demand for fossil fuel use for electricity-generating purposes. Therefore, the incremental reduction in fossil fuels would be a positive effect of the commitment of nonrenewable resources. Additionally, the project is consistent with the state's definition of an "eligible renewable energy resource" in Section 399.12 of the California Public Utilities Code and the definition of "in-state renewable electricity generation facility" in Section 25741 of the California PRC.

1. The County of Imperial (the County), acting through the Board of Supervisors, is the Lead Agency for the project evaluated in the EIR. The County finds that the EIR was prepared in compliance with CEQA and the CEQA Guidelines. The County finds that it has independently reviewed and

analyzed the EIR for the project, that the Draft EIR which was circulated for public review reflected its independent judgment and that the Final EIR reflects the independent judgment of the County.

2. The County finds that the EIR provides objective information to assist the decision-makers and the public at large in their consideration of the environmental consequences of the project. The public review period provided all interested jurisdictions, agencies, private organizations, and individuals the opportunity to submit comments regarding the Draft EIR. The Final EIR was prepared after the review period and responds to comments made during the public review period.
3. The Planning and Development Services Department evaluated comments on environmental issues received from persons who reviewed the Draft EIR. In accordance with CEQA, the Planning and Development Services Department prepared written responses describing the disposition of significant environmental issues raised. The Final EIR provides adequate, good faith and reasoned responses to the comments. The Planning Department reviewed the comments received and responses thereto and has determined that neither the comments received nor the responses to such comments add significant new information regarding environmental impacts to the Draft EIR. The Lead Agency has based its actions on full appraisal of all viewpoints, including all comments received up to the date of adoption of these findings, concerning the environmental impacts identified and analyzed in the EIR.
4. The EIR evaluated the following potential project and cumulative environmental impacts:
 - Aesthetics
 - Agriculture Resources
 - Air Quality
 - Biological Resources
 - Cultural Resources
 - Geology and Soils
 - GHG Emissions
 - Hazards and Hazardous Materials
 - Hydrology/Water Quality
 - Land Use/Planning
 - Noise and Vibration
 - Transportation
 - Tribal Cultural Resources
 - Utilities/Service Systems (Water Supply)

Additionally, the EIR considered, in separate sections, Analysis of Long-Term Effects and potential secondary effects of the project. The significant environmental impacts of the project were identified in the Final EIR. The significant environmental impacts of the project and the alternatives were also identified in the Draft and Final EIR.

5. The mitigation measures which have been identified for the project were identified in the Draft and Final EIR. The final mitigation measures are described in the MMRP. Each of the mitigation measures identified in the MMRP, and contained in the Final EIR, is incorporated into the project.

The County finds that the impacts of the project have been mitigated to the extent feasible by the mitigation measures identified in the MMRP, and contained in the Final EIR.

6. Textual refinements and errata were compiled and presented to the decision-makers for review and consideration. The Planning and Development Services Department staff has made every effort to notify the decision-makers and the interested public/agencies of each textual change in the various documents associated with the project review. These textual refinements arose for a variety of reasons. First, it is inevitable that draft documents would contain errors and would require clarifications and corrections. Second, textual clarifications were necessitated in order to describe refinements suggested as part of the public participation process.
7. The responses to the comments on the Draft EIR, which are contained in the Final EIR, clarify and amplify the analysis in the Draft EIR.
8. Having reviewed the information contained in the EIR and in the administrative record as well as the requirements of CEQA and the CEQA Guidelines regarding recirculation of Draft EIRs, the County finds that there is no new significant information in the Final EIR, finds that the additional information provided therein merely clarifies, amplifies and/or makes insignificant modifications to the adequate Draft EIR, and finds that recirculation of the Draft EIR is not required.
9. CEQA requires the Lead Agency approving a project to adopt an MMRP for the changes to the project which it has adopted or made a condition of project approval in order to ensure compliance with the mitigation measures during project implementation. The mitigation measures included in the EIR as certified by the County and included in the MMRP as adopted by the County serves that function. The MMRP includes all of the mitigation measures identified in the EIR and adopted by the County in connection with the approval of the project and has been designed to ensure compliance with such measures during implementation of the project. In accordance with CEQA, the MMRP provides the means to ensure that the mitigation measures are fully enforceable. In accordance with the requirements of Public Resources Code §21081.6, the County hereby adopts the MMRP.
10. In accordance with the requirements of Public Resources Code §21081.6, the County hereby adopts each of the mitigation measures expressly set forth herein as conditions of approval for the project.
11. The custodian of the documents or other material which constitute the record of proceedings upon which the County's decision is based is the Imperial County Planning and Development Services Department, 801 Main Street, El Centro, California, 92243.
12. The County finds and declares that substantial evidence for each and every finding made herein is contained in the EIR, which is incorporated herein by this reference, or is in the record of proceedings in the matter.
13. The County is certifying an EIR for, and is approving and adopting findings for, the entirety of the actions described in these Findings and in the EIR as comprising the project. It is contemplated that there may be a variety of actions undertaken by other State and local agencies (who might be referred to as "responsible agencies" under CEQA). Because the County is the Lead Agency for the project, the EIR is intended to be the basis for compliance with CEQA for each of the possible discretionary actions by other State and local agencies to carry out the project.
14. The EIR is a Project EIR for purposes of environmental analysis of the project. A Project EIR examines the environmental effects of a specific project. The EIR serves as the primary

environmental compliance document for entitlement decisions regarding the project by the County of Imperial and the other regulatory jurisdictions.



This page is intentionally blank.

VEGA SES 4 Solar Energy Project Errata to the Draft EIR For Proposed Grays Wells Road Heavy Construction Equipment/Vehicle Access

A. INTRODUCTION

The VEGA SES 4 Draft EIR analyzed a heavy construction equipment/vehicle access route to the project site via Gordon Wells Road. Subsequent to the preparation of the VEGA SES 4 Draft EIR, the project applicant has identified a potential second heavy construction equipment/vehicle access option via Grays Wells Road, a portion of which, was not contemplated in the Draft EIR analysis. The following provides a description of the Gordon Wells Road heavy construction equipment/vehicle access as analyzed in the Draft EIR and the secondary heavy construction equipment/vehicle access option via Grays Wells Road. This Errata indicates where minor revisions to the Draft EIR would be required in order to incorporate the Grays Wells Road access option and provides a corresponding environmental analysis of this second heavy construction equipment/vehicle access option. Based on the project description of the Grays Wells Road heavy construction equipment/vehicle access option and corresponding environmental analysis, the County has determined that an Errata is the appropriate CEQA documentation to address the potential access route, and that no new significant impacts or recirculation of the Draft EIR is required.

Gordon Wells Road - Heavy Construction Equipment/Vehicle Access. The VEGA SES 4 Solar Energy Project Final EIR, State Clearinghouse No. 2021050018 ("Final EIR"), describes potential environmental impacts resulting from the use of a heavy construction equipment/vehicle construction access route that would obtain access to the project site from Gordon Wells Road indirectly off of the I-8 Freeway. As stated in the Final EIR, Section 2.4.2 Heavy Construction Equipment Access (Final EIR page 2-10), it was determined heavy construction vehicles would cross the All-American Canal at Gordon Wells Road located approximately 20 miles east of the project site. Final EIR **Error! Reference source not found.** (Final EIR page 2-13) depicts the proposed route. This route is approximately 20-miles in length. With this heavy vehicle access option, access for heavy construction vehicles to and from the project site requires crossing the All-American Canal, via two existing bridges as shown in Final EIR **Error! Reference source not found.** These two bridges are located along Gordon Wells Road. Gordon Wells Road has an interchange with I-8. The bridges over the canal were constructed in 2009. The bridges are rated as open with no restrictions and have a "Good" condition rating.

An estimated two trucks would arrive at the project site each day during the first few weeks of construction of the solar facility.

Grays Wells Road – Heavy Construction Equipment/Vehicle Access (Second Option). Subsequent to circulation of the Draft EIR, a potential second option has been identified by the project applicant based

on further discussions with IID, the Border Patrol/Department of Homeland Security, and the Bureau of Land Management (BLM). The second access option would take access off of Grays Wells Road and has a direct connection via the I-8. The route is approximately 27 miles in length. As with the Gordon Wells Road access, this option would require the applicant to obtain appropriate right of way (ROW) approvals from the BLM and approvals from the Border Patrol. This access option would utilize a paved frontage road that starts east of the All American Canal and extends east to the existing I-8 rest stop and BLM desert office. There is a gap between that frontage road and the border road that currently is a dirt trail which the project applicant would construct minimal improvements sufficient to carry large vehicles, but not be paved per request of the BLM. The proposed area to be graded (that is not otherwise paved frontage road or existing border patrol dirt road) is approximately 1.43 miles in length.

As noted above, either access option (Gordon Wells Road or Grays Wells Road), heavy vehicle access will require approvals by the BLM and Border Patrol/Department of Homeland Security. As indicated in the Draft EIR, the applicant has entered into a Memorandum of Understanding with the U.S. Border Patrol setting forth the project-related activities that may occur on this existing dirt road used by the U.S. Border Patrol.

The following ROW requests have been brought forward by the project applicant to the BLM in support of this project, which address both the Gordon Wells Road and Grays Wells Road access options, although the Grays Wells Road access would involve additional ROW approvals by BLM specifically for the heavy vehicle access routes include:

- 60 foot wide ROW for the existing direct frontage road that parallels the international border/fence
- 60 foot wide ROW for the existing paved frontage road between the I-8 rest stop/BLM Desert office and the border road. This area is currently a desert dirt trail used extensively by off road vehicles.
- **Heavy Construction Equipment Access:** Vendors and heavy construction equipment would exit both from the south and north from Interstate 8 onto Greys Wells Road approximately 24miles east of the project site, then travel west along an and existing paved road that ends at a cul-de-sac. From the cul-de-sac, a short section of an existing dirt road would connect to the existing dirt road paralleling the U.S./Mexico Border. The connecting dirt road between the paved road and the border road would be improved to BLM requirements.
- **Right of Way.** The ROW that is being requested for the border road as well as the transition to the paved road and the paved road only needs to be the width of the existing roads and is currently calculated at no more than 60 feet.

The minor re-alignment of a proposed access road would also not result in an increase in any impact already addressed in the Draft EIR.

This section of the Final Environmental Impact Report (EIR) identifies the location of, or contains revisions to, information included in the Draft EIR. The information added to the EIR does not meet the requirements for recirculation pursuant to Section 15088.5 of the State *California Environmental Quality Act (CEQA) Guidelines*. The new information simply clarifies information presented in the Draft EIR. Text

that has been added to the document appears in an underline format. Text that has been deleted appears with strikeout.

This Errata, in conjunction with the Final EIR, will be used by the County of Imperial in its evaluation and analysis of the proposed project and in the adoption of any findings required by law. Substantial evidence in support of findings may be found anywhere in the administrative record. (14CCR 15091(b)(e). The County of Imperial is designated the Lead Agency for California Environmental Quality Act (CEQA) compliance.

This Errata provides further detail as to this potential heavy vehicle access option.

B. CORRECTIONS AND ADDITIONS

SECTION 1 INTRODUCTION

Page 1-3

1.1.1 Agency Roles and Responsibilities

Federal

United States Border Patrol

- The project applicant and U.S. Border Patrol will develop and enter into a Memorandum of Understanding (MOU) setting forth the project-related activities that may occur on an existing dirt road used by the U.S. Border Patrol.

Bureau of Land Management – California Desert District U.S. Department of the Interior – Region 8 El Centro Field Office

- The project applicant will be required to obtain a Right of Way (ROW) from the Bureau of Land Management (BLM) for any heavy construction equipment/vehicle access routes that may traverse BLM managed public lands. Should the proposed Gordon Wells Road heavy equipment access route not be utilized, a second option is proposed utilizing Grays Wells Road as described in further detail in Chapter 2 Project description.

SECTION 2 PROJECT DESCRIPTION

Page 2-9:

Heavy Construction Equipment Access: Vendors and heavy construction equipment would exit south from Interstate 8 onto Gordon Wells Road approximately 20 miles east of the project site, then travel west along an existing dirt road paralleling the U.S./Mexico Border (**Error! Reference source not found.**). See Section 2.4.2 for a detailed description of this access route for heavy construction equipment. The applicant has entered into a Memorandum of Understanding with the U.S. Border Patrol setting forth the project-related activities that may occur on this existing dirt road used by the U.S. Border Patrol (see Section 2.7.3 for a detailed discussion). The second option for means of access to be used for heavy truck loads would be along the border frontage road used by Home Land Security/Border Protection primarily. This road however does not connect directly to the I-8 corridor. Therefore; an additional connection is required east of Gordons Well where another (paved) frontage road starts east of the All American Canal

and goes east to the I – 8 rest stop, and BLM desert office. There is a gap between that frontage road and the border road that currently is a dirt trail which the proponent would improve with minimal improvements sufficient to carry large vehicles, but not be paved per request of the BLM. This proposed route is shown in Figure 2-6b.

Page 2-10

2.4.2 Heavy Construction Equipment Access

Following discussions with the IID, it was determined heavy construction vehicles would cross the All-American Canal at Gordon Wells Road located approximately 20 miles east of the project site (**Error! Reference source not found.**). Access for heavy construction vehicles to and from the project site requires crossing the All-American Canal, via two existing bridges (**Error! Reference source not found.**), located along Gordon Wells Road. Gordon Wells Road has an interchange with I-8. The bridges over the canal were constructed in 2009. The bridges are rated as open with no restrictions and have a “Good” condition rating. The second option for means of access to be used for heavy truck loads would be along the border frontage road used by Home Land Security/Border Protection primarily. This road however does not connect directly to the I-8 corridor. Therefore an additional connection is required east of Gordons Well where another (paved) frontage road starts east of the All American Canal and goes east to the I – 8 rest stop, and BLM desert office. There is a gap between that frontage road and the border road that currently is a dirt trail which the proponent would improve with minimal improvements sufficient to carry large vehicles, but not be paved per request of the BLM. This proposed route is shown in Figure 2-6b.

Page 2-19

2.7.4 Bureau of Land Management – California Desert District U.S. Department of the Interior – Region 8 El Centro Field Office

The project applicant will be required to obtain a Right of Way (ROW) from the Bureau of Land Management (BLM) for any heavy equipment access routes that may traverse BLM managed public lands. Should the proposed Gordon Wells Road heavy equipment access route not be utilized, a second option is proposed utilizing Grays Wells Road as described in further detail in Chapter 2 Project description.

Section 3.4 Air Quality

Page 3.4-14

Methodology

All heavy-duty construction vehicles would cross the All-American Canal at Gordon Wells Road located approximately 20 miles east of the project site. An estimated two trucks hauling construction equipment and project materials would arrive at the project site each day during the first few weeks of construction via Gordon Wells Road and the 20 miles of existing dirt road paralleling the U.S./Mexico Border. The PM emissions associated with two haul trucks traversing this existing dirt road to and from the site daily are accounted for. Use of either heavy equipment access Option 1 or Option 2 (i.e., via Gordon Wells Road or via Grays Wells Road) would require implementation of the same dust control measure and construction equipment emissions reduction measures as required by Mitigation Measures AQ-1 through AQ-3. The Grays Wells Road is paved, with the exception of an 1.43-mile length segment that would be graded in

addition to what would otherwise be required for the Gordon Wells Road option, which was evaluated in the Draft EIR. This minor increase in grading would not result in an increase in construction emissions that would exceed ICAPCD significance thresholds. As identified in Draft EIR Table 3.4-8 Project Construction-Generated Emissions – Mitigated, mitigated construction emissions are well below the threshold criteria for criteria pollutants – include PM10 and PM2.5. The use of an additional 1.43-mile length for unpaved construction access would not significantly increase the daily emissions.

Page 3.4-14

- **Heavy Construction Equipment Access:** Vendors and heavy construction equipment would exit south from Interstate 8 onto Gordon Wells Road approximately 20 miles east of the project site, then travel west along an existing dirt road paralleling the U.S./Mexico Border. The second option for means of access to be used for heavy truck loads would be along the border frontage road used by Home Land Security/Border Protection primarily. This road however does not connect directly to the I-8 corridor. Therefore, an additional connection is required east of Gordons Well where another (paved) frontage road starts east of the All American Canal and goes east to the I – 8 rest stop, and BLM desert office. There is a gap between that frontage road and the border road that currently is a dirt trail which the proponent would improve with minimal improvements sufficient to carry large vehicles, but not be paved per request of the BLM.

Section 3.5 Biological Resources

Page 3.5-13

Urban/Developed

Urban/Developed areas do not constitute a vegetation classification, but rather a land cover type. Areas mapped as developed have been constructed upon or otherwise physically altered to an extent that natural vegetation communities are no longer supported. There may be irrigated landscaped, ornamental species present between the hardscape. On the project site, this land cover was dominant and consisted primarily of compacted dirt roads, structures, and landscape trees including Mexican fan palm (*Washingtonia robusta*) and Mexican palo verde (*Parkinsonia aculeata*). The entirety of the Gordon Wells Road heavy vehicle access road (Option 1) is this land cover type. The majority of the Grays Wells Road heavy vehicle access road (Option 2) is Urban/Developed (paved road) and Urban/Developed – Dirt Road. However, a 1.43-mile segment would traverse creosote bush scrub, disturbed creosote bush scrub, and/or creosote bush-white bursage scrub.

Page 3.5-36

The palm trees located within the project site may provide roosting habitats for bat species, particularly western yellow bat, a SSC species. These trees could function as maternity roost sites for this species. During the 2022 assessment of the access road, a bat roost was observed within the bridge at Gordon Wells Road that crosses the offline storage canal, north of the All-American Canal. Bat species in California are protected by Section 4150 (protection of non-game mammals from take) of the California Fish and Game Code. Section 4150 of the California Fish and Game Code prohibits the take of any naturally occurring mammals in California that are nongame mammals, which includes all species of the Order Chiroptera (bats). Based on the quantity of bats within the bridge and the timing of the observation of the colony, there is high likelihood that this is a maternity roost. If implemented as a heavy equipment access route, the Gordon Wells Road bridge will be used for access

May 5, 2023

to the solar field portion of the project site and no direct impacts are expected to occur to the bridge. However, there may be indirect impacts to the roost through noise and vibration, due to a temporary increase in traffic above the bridge during construction. However, because the bridge currently functions as an active roadway, the colony would be expected to be accustomed to noise and vibrations associated with traffic and indirect impacts would not be expected to be significant. The solar facility site is located approximately 22 miles west of the bridge and work is expected to occur within a 12-month period. An increase in truck traffic over the bridge to facilitate construction of the project is not expected to have a significant impact on the bat colony and will be temporary in nature. If the Gray Wells Road heavy equipment access route is utilized, there would be no vehicles utilizing the Gordon Wells Road bridge and therefore would avoid any potential indirect impacts to bats.

Page 3.5-37

Special Status Wildlife

CONSTRUCTION ACCESS ROAD

During construction, vendors and heavy construction equipment would access the project site via either Gordon Wells Road approximately 20 miles east of the project site, or Gray Wells Road east of the project site. For each of these options, vehicles would traverse existing paved roads and existing dirt roads. Each option would travel ~~then travel~~ west along an existing dirt road paralleling the U.S./Mexico Border for the majority of the route. This existing dirt road is actively used by the U.S. Border Patrol during patrol operations. The dirt road is on urban/developed land. The use of this access road during construction is not anticipated to result in potential impacts on biological resources, with the exception of roosting bats, if present only in the circumstance where the Gordon Wells Bridge would be traversed under the Gordon Wells Road option. Bat acoustic surveys and monitoring should be implemented to determine if sensitive bat species occur within the Gordon Road Wells bridge or palm trees (if planned for removal). All bat species with potential for occurrence for the project are SSC species and potential project-related impacts to bat species and bat maternity roosts are considered significant. Implementation of BIO-7 would reduce impacts to bat species and maternity roosts to a level less than significant.

Because vehicles and construction equipment would be required to stay within the existing boundaries of the existing paved road and existing dirt road to avoid and/or minimize ground disturbance to undisturbed and vegetated areas, other impacts to biological resources are not anticipated. Furthermore, the project applicant would not make improvements to the existing dirt road except for the application of water for dust suppression.

Page 3.5-43

Impact 3.5-2 Riparian Habitat and Sensitive Natural Communities

CONSTRUCTION ACCESS ROAD

The existing dirt access road is on urban/developed land. No riparian habitat or sensitive natural communities are located within or adjacent to the access road. The majority of the Grays Wells Road heavy vehicle access road (Option 2) is Urban/Developed (paved road) and Urban/Developed – Dirt Road. However, a 1.43-mile segment would traverse creosote bush scrub, disturbed creosote bush scrub, and/or creosote bush-white bursage scrub. The access road would not traverse any identified riparian habitats. Therefore, the use of the access road during construction would have no impact on riparian or sensitive natural communities.

May 5, 2023

Impact 3.5-3 State or Federally Protected Wetlands

CONSTRUCTION ACCESS ROAD

CONSTRUCTION ACCESS ROAD

The existing dirt access road is on urban/developed land. No aquatic resources are located within or adjacent to the access road. The majority of the Grays Wells Road heavy vehicle access road (Option 2) is Urban/Developed (paved road) and Urban/Developed – Dirt Road. However, a 1.43-mile segment would traverse creosote bush scrub, disturbed creosote bush scrub, and/or creosote bush-white bursage scrub. The access road would not traverse any identified state or federally protected wetlands. Therefore, the use of the access road during construction would have no impact on riparian or sensitive natural communities.

Impact 3.5-4 Interfere with Wildlife Movement

ACCESS ROAD

The existing dirt access road is on urban/developed land. The portion of Grays Wells Road that would be graded would not interfere wildlife movement. The majority of the road is a paved frontage road and is otherwise in the vicinity of other barriers to wildlife movement including canals and the I-8 Freeway. Additionally, the access road would not be fenced. Therefore, the use of the access road during construction would have no impact on wildlife movement.

Page 3.5-44

Impact 3.5-5 Conflict With Policies or Ordinances Protecting Biological Resources

CONSTRUCTION ACCESS ROAD

The use of the access road (either Gordon Wells Road access option of Grays Wells Road access option) during construction is not anticipated to result in potential impacts on biological resources because vehicles and construction equipment would be required to stay within the existing boundaries of the dirt road to avoid and/or minimize ground disturbance to undisturbed and vegetated areas. Furthermore, the project applicant would not make improvements to the existing dirt road except for the application of water for dust suppression. Based on these considerations, the use of either ~~the~~ access road during construction would not conflict with local policies protecting biological resources.

Page 3.5-45

Impact 3.5-6 Conflict with Habitat Conservation Plan

CONSTRUCTION ACCESS ROAD

The construction access road (either Gordon Wells Road access option of Grays Wells Road access option) is not located in a Habitat Conservation Plan, Natural Community Conservation Plan, or other approved local, regional, or state habitat conservation plan. Therefore, the use of either ~~the~~ access road during construction would result in no impact associated with the potential to conflict with local conservation plans.

Section 3.6 Cultural Resources

Page 3.6-16

May 5, 2023

Impact 3.6-1 Cause a substantial adverse change in the significance to a historical resource

ACCESS ROAD

During construction, vendors and heavy construction equipment would access the project site via Gordon Wells Road approximately 20 miles east of the project site, then travel west along an existing dirt road paralleling the U.S./Mexico Border. This existing dirt road is actively used by the U.S. Border Patrol during patrol operations. The use of this access road during construction is not anticipated to result in potential impacts on cultural resources because vehicles and construction equipment would be required to stay within the existing boundaries of the dirt road to avoid and/or minimize ground disturbance to undisturbed and vegetated areas. Furthermore, the project applicant would not make improvements to the existing dirt road except for the application of water for dust suppression. No grading or excavation would occur to the dirt road as a result of the project. Similarly, the Grays Wells Road heavy vehicle access option is the same route as the Gordon Wells Road access route; however, it would extend further east. A segment of this is an existing trail used by off-road vehicles; however, the majority is paved frontage road. There is a low potential that cultural resources would be identified within the area of the Grays Wells Road heavy vehicle access; and Draft EIR Cultural Resources mitigation measure CR-1 would be applicable to this proposed access route. Based on these considerations, the potential to impact cultural resources is considered low and a less than significant impact would occur.

Page 3.6-17

Impact 3.6-2 Cause a substantial adverse change in the significance of an archaeological resource

ACCESS ROAD

During construction, vendors and heavy construction equipment would access the project site via Gordon Wells Road approximately 20 miles east of the project site, then travel west along an existing dirt road paralleling the U.S./Mexico Border. This existing dirt road is actively used by the U.S. Border Patrol during patrol operations. The use of this access road during construction is not anticipated to result in potential impacts on archaeological resources because vehicles and construction equipment would be required to stay within the existing boundaries of the dirt road to avoid and/or minimize ground disturbance to undisturbed and vegetated areas. Furthermore, the project applicant would not make improvements to the existing dirt road except for the application of water for dust suppression. No grading or excavation would occur to the dirt road as a result of the project. Similarly, the Grays Wells Road heavy vehicle access option is the same route as the Gordon Wells Road access route; however, it would extend further east. A segment of this is an existing trail used by off-road vehicles; however, the majority is paved frontage road. There is a low potential that cultural resources would be identified within the area of the Grays Wells Road heavy vehicle access; and Draft EIR Cultural Resources mitigation measure CR-2 would be applicable to this proposed access route. Based on these considerations, the potential to impact archaeological resources is considered low and a less than significant impact would occur.

Page 3.6-18

Impact 3.6-3 Disturb Human Remains

ACCESS ROAD

May 5, 2023

During construction, vendors and heavy construction equipment would access the project site via Gordon Wells Road approximately 20 miles east of the project site, then travel west along an existing dirt road paralleling the U.S./Mexico Border. This existing dirt road is actively used by the U.S. Border Patrol during patrol operations. The use of this access road during construction is not anticipated to result in potential impacts on archaeological resources because vehicles and construction equipment would be required to stay within the existing boundaries of the dirt road to avoid and/or minimize ground disturbance to undisturbed and vegetated areas. Furthermore, the project applicant would not make improvements to the existing dirt road except for the application of water for dust suppression. No grading or excavation would occur to the dirt road as a result of the project. Similarly, the Grays Wells Road heavy vehicle access option is the same route as the Gordon Wells Road access route; however, it would extend further east. A segment of this is an existing trail used by off-road vehicles; however, the majority is paved frontage road. There is a low potential that cultural resources would be identified within the area of the Grays Wells Road heavy vehicle access; and Draft EIR Cultural Resources mitigation measures CR-3 would be applicable to this proposed access route. Based on these considerations, the potential to encounter human remains is considered low and a less than significant impact would occur.

Section 3.13 Transportation

Impact 3.13-4 Project Result in Inadequate Emergency Access?

Page 3.13-8

Vehicular access to the project site is currently provided via an existing driveway along SR-98. Under the proposed project, vehicular access for workers would continue to be provided via the existing driveway as the project would not require additional storage lanes or lengths along SR-98. Following discussions with the Imperial Irrigation District, it was determined heavy construction vehicles would cross the All-American Canal at Gordon Wells Road located approximately 20 miles east of the project site (**Error! Reference source not found.**). Access for heavy construction vehicles to and from the project site requires crossing the All-American Canal, via two existing bridges (**Error! Reference source not found.**), located along Gordon Wells Road. Gordon Wells Road has an interchange with I-8. The bridges over the canal were constructed in 2009. The bridges are rated as open with no restrictions and have a “Good” condition rating. The second means of access to be used for heavy truck loads would be along the border frontage road used by Home Land Security/Border Protection primarily. This road however does not connect directly to the I-8 corridor. Therefore an additional connection is required east of Gordons Well where another (paved) frontage road starts east of the All American Canal and goes east to the I – 8 rest stop, and BLM desert office. There is a gap between that frontage road and the border road that currently is a dirt trail which the proponent would improve with minimal improvements sufficient to carry large vehicles, but not be paved per request of the BLM. This proposed route is shown in Figure 2-6b.

C. CALIFORNIA ENVIRONMENTAL QUALITY ACT REQUIREMENTS AND FINDINGS SUPPORTING DECISION NOT TO RECIRCULATE

CEQA Section 15088.5(e) requires that an EIR which has been made available for public review, but not yet certified, be recirculated whenever significant new information has been added to the EIR. The entire

document need not be recirculated, if revisions are limited to specific portions of the document. The recirculated portions of document must be sent to responsible and trustee agencies for consultation and fresh public notice must be given in the manner provided for a draft EIR. However, new information is not presumed to be significant simply because it is new. Indeed, pursuant to State CEQA Guidelines Section 15088.5:

New information added to an EIR is not "significant" unless the EIR is changed in a way that deprives the public of a meaningful opportunity to comment upon a substantial adverse environmental effect of the project or a feasible way to mitigate or avoid such an effect . . . that the project's proponents have declined to implement. State CEQA Guidelines, § 15088.5(a):

In order to be "significant," the new information requiring recirculation includes, for example, a disclosure showing that:

- (1) A new significant environmental impact would result from the project or from a new mitigation measure proposed to be implemented.
- (2) A substantial increase in the severity of an environmental impact would result unless mitigation measures are adopted that reduce the impact to a level of insignificance.
- (3) A feasible project alternative or mitigation measure considerably different from other previously analyzed would clearly lessen the environmental impacts of the project, but the project's proponent decline to adopt it.
- (4) The draft EIR was so fundamentally and basically inadequate and conclusory in nature that meaningful public review and comment were precluded. (State CEQA Guidelines, §15088.5(a)(1)-(4); *Laurel Heights II*, 6 Cal.4th at 1120.)

It is common, and in most cases necessary, to amplify and elaborate on the analysis of an EIR. CEQA anticipates this and such amplification does not constitute significant new "information" unless it triggers one of the four categories described in State CEQA Guidelines Section 15088.5(a). State CEQA Guidelines Section 15088.5(b) provides that "recirculation is not required where the new information added to the EIR merely clarifies or amplifies or makes insignificant modifications in an adequate EIR."

Based upon review of the minor corrections and additions identified in Section A above, and the additional analyses provided in Table 0.3-1, the minor corrections and additions do not result in any new or substantially increased significant impacts. Additionally, the potential second access option using Grays Wells Road would not result in any new or substantially increased significant impacts. Therefore, the County has concluded that recirculation of the Draft EIR is not required.

Discussion of Environmental Impacts

The Draft EIR for the VEGA SES 4 Solar Energy project evaluated 14 environmental impacts and issues, including: aesthetics and visual resources; agricultural resources; air quality; biological resources; cultural resources; geology and soils; greenhouse gas emissions; hazards; hydrology/water quality; land use planning; noise and vibration; transportation; tribal cultural resources; and utilities and service systems.

May 5, 2023

Table 0.3-1 lists each environmental topic evaluated in the Draft EIR and summarizes whether the proposed second heavy vehicle access option would change any impacts associated with the project. As shown, implementation of the Grays Wells Road heavy vehicle access option would not change the analysis of the Draft EIR. Furthermore, no change to the type of proposed mitigation measures would be required.

Table 0.3-1

Summary of Environmental Impacts

Environmental Issue Area	Summary of Potential Impact
3.2 Aesthetics and Visual Resources	No change. The addition of the Grays Wells Road heavy vehicle access option would not result in a significant visual impact. If implemented, the majority of the additional stretch of road would be located on existing paved road, and only grading of 1.43 miles of the route is required, but would remain unpaved and restored after project construction. The project, including proposed construction access roads is not located in an area subject to a designated scenic vista, is not located in proximity to a formally-designated scenic highway, and would not degrade the visual character of the area. Based on analysis contained within the Draft EIR, impacts to visual resources resulting from the implementation of the proposed project, including both construction and operation of the project, would not result in a significant impact. Use of the proposed Grays Wells Road heavy vehicle access option would not change this conclusion. Therefore, there would be no change to the Draft EIR conclusions related to aesthetics and visual resources.
3.3 Agricultural Resources	No change. Implementation of the Grays Wells Road heavy equipment access option would not impact agricultural resources. There are no agricultural lands located within the alignment of this proposed access. The project site (including proposed construction access routes) does not contain Prime Farmland, Farmland of Statewide Importance, or Unique Farmland. Therefore, the proposed project would not convert land designated as Prime Farmland, Farmland of Statewide Importance, or Unique Farmland to non-agricultural uses. The Draft EIR concludes that with implementation of Pest Management Plan (which is not applicable to the proposed construction access roads), the project’s impact to agricultural resources would be less than significant. Use of the proposed Grays Wells Road heavy vehicle access option would not change this conclusion. Therefore, there would be no change to the Draft EIR conclusions related to agricultural resources.
3.4 Air Quality	No change. The Draft EIR analysis of the proposed project concludes that with the implementation of Mitigation Measures AQ-1 through AQ-3, the proposed project would not result in short-term air quality impacts during construction. Use of either heavy equipment access Option 1 or Option 2 (i.e., via Gordon Wells Road or via Grays Wells Road) would require implementation of the same dust control measure and construction equipment emissions reduction measures as required by Mitigation Measures AQ-1 through AQ-3. The Grays Wells Road is paved, with the exception of an 1.43 mile segment that would be graded in addition to what would otherwise be required for the Gordon Wells Road option, which was evaluated in the Draft EIR. This minor increase in grading would not result in an increase in construction emissions that would exceed ICAPCD significance thresholds. As identified in Draft EIR Table 3.4-8 Project Construction-Generated Emissions – Mitigated, mitigated construction emissions are well below the threshold criteria for criteria pollutants – include PM10 and PM2.5. The use of an additional 1.43 miles

	<p>of unpaved construction access would not significantly increase the daily emissions as the same construction vehicle equipment fleet mix would remain the same on a daily basis. Long-term (operational) use of this access would be intermittent (only as required for infrequent Therefore, there would be no change to this conclusion. Therefore, there would be no change to the Draft EIR conclusions related to air quality.</p>
3.5 Biological Resources	<p>No change. The majority of the proposed Grays Wells Road secondary on-site wireless communication facility would be located within the disturbance footprint evaluated in Section 3.4 Biological Resources of the Draft EIR. Therefore, there would be no change to the Draft EIR conclusions related to biological resources.</p>
3.6 Cultural Resources	<p>No change. The proposed Grays Wells Road option would follow the Gordon Wells Road option as evaluated in the Draft EIR. However, this option also would be located on existing paved frontage road, but would extend through an area approximately 1.43 miles in length, that is currently on off-road recreational vehicle trail. Implementation of Mitigation Measures CR-1 through CR-4 would reduce potential impacts to cultural resources to a level less than significant. These mitigation measures would be applicable to the Grays Wells Road access option, and may be further refined as part of the BLM review of the ROW application and required as part of any ROW approvals. Therefore, there would be no change to the Draft EIR conclusions related to cultural resources.</p>
3.7 Geology and Soils	<p>No change. Geotechnical conditions would not change or be affected by the Grays Wells Road heavy vehicle access option and is located in an area determined geotechnically suitable for construction of the project. There would be no permanent structures constructed for the access route. Therefore, there would be no change to the Draft EIR conclusions related to geology and soils.</p>
3.8 Greenhouse Gas Emissions	<p>No change. The Draft EIR analysis of the proposed project concludes that the proposed project would not result in short-term or long-term operational greenhouse gas (GHG) emissions impacts. The construction and use of the Grays Wells Road access alternative would require limited use of equipment, and would be the same as evaluated in the Draft EIR, which would not generate significant GHG emissions as amortized over the life of the project. Therefore, there would be no change to the Draft EIR conclusions related to greenhouse gas emissions.</p>
3.9 Hazards	<p>No change. There are no hazardous sites located within the proposed Grays Wells Road heavy vehicle access option. The use of this access would be subject to the same best management practices regarding use, storage and disposal of hazardous materials associated with construction activities as identified in the EIR, or as otherwise required by BLM as a condition of granting the required ROW. Therefore, there would be no change to the Draft EIR conclusions related to hazards.</p>
3.10 Hydrology/Water Quality	<p>No change. The proposed use of the Grays Wells Road heavy vehicle access option would be subject to same or similar drainage and stormwater quality control requirements as identified in the Draft EIR, and as may otherwise be required by BLM as a condition of the ROW approval. Therefore, there would be no change to the Draft EIR conclusions related to hydrology and water quality.</p>
3.11 Land Use Planning	<p>No change. The proposed use of the Grays Wells Road heavy vehicle access option would not change the proposed project use. The project applicant would be required to obtain ROW approvals from the BLM, which would be granted only if BLM determines the ROW request would not be in conflict with applicable plans</p>

VEGA SES 4 Solar Energy Project – Errata to the Draft EIR for proposed Grays Wells Road Heavy Construction Equipment/Vehicle Access





	under BLM’s purview. Therefore, there would be no change to the Draft EIR conclusions related to land use planning.
3.12 Noise and Vibration	No change. The use of the Grays Wells Road heavy vehicle access option would not create a noise or vibration impact. There are no sensitive receptors located in proximity to this proposed access route. Therefore, there would be no change to the Draft EIR conclusions related to noise and vibration.
3.13 Transportation	No change. The use of the Grays Wells Road heavy vehicle access option would not affect traffic as this route is an off-road access route and existing and planned transportation facilities would not be affected. Therefore, there would be no change to the Draft EIR conclusions related to transportation/traffic.
3.14 Tribal Cultural Resources	No change. The use of the Grays Wells Road heavy vehicle access option would not affect any tribal cultural resources as none have been identified in the project area. Therefore, there would be no change to the Draft EIR conclusions related to tribal cultural resources.
3.15 Utilities and Service Systems	No change. The use of the Grays Wells Road heavy vehicle access option would not place a demand on utilities or service systems. Therefore, there would be no change to the Draft EIR conclusions related to utilities/service systems.

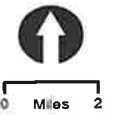
VEGA SES 4 Solar Energy Project – Errata to the Draft EIR for proposed Grays Wells Road Heavy Construction Equipment/Vehicle Access

Figure 2.6b



Legend

-  Project Location
-  Access Road Option 1
-  Access Road Option 2 (Paved)
-  Access Road Option 2 to be Graded



Attachment D:
MMRP

RESOLUTION NO.

A RESOLUTION OF THE BOARD OF SUPERVISORS OF THE COUNTY OF IMPERIAL, CALIFORNIA, FOR APPROVAL OF THE MITIGATION MONITORING AND REPORTING PROGRAM FOR THE VEGA SES 4 SOLAR ENERGY STORAGE PROJECT

WHEREAS, a Mitigation Monitoring and Reporting Program has been prepared in accordance with the requirements of the California Environmental Quality Act, the State CEQA Guidelines, and the County's Rules to Implement CEQA as amended; and,

WHEREAS, the Board of Supervisors of the County of Imperial has been delegated with the responsibility of the of the Mitigation Monitoring and Reporting Program; and

WHEREAS, public notice of said application has been given, and Board of Supervisors has considered evidence presented by the Imperial County Planning & Development Services Department, and other interested parties at a public hearing held with respect to this item on October 24, 2023; and,

NOW THEREFORE, the Board of Supervisors of the County of Imperial **DOES HEREBY RESOLVE** as follows:

SECTION 1. The Board of Supervisors has considered the proposed Mitigation Monitoring and Reporting Program (MM&RP) prior to deciding to adopt the proposed MM&RP. The Board of Supervisors finds and determines that the Environmental Impact Report is adequate and prepared in accordance with the requirements of the California Environmental Quality Act (CEQA), which analyzes environmental effects, based upon the following findings and determinations.

SECTION 2. That in accordance with CEQA, State Planning and Zoning law, Imperial County Land Use Ordinance and the County of Imperial General Plan, the following findings for consideration of the MM&RP as follows:

1. That the Final Project EIR **SCH #2021050018**, Candidate CEQA Findings for the Vega SES Solar Energy Storage Project ("Project") have been prepared in accordance with the requirements of the California Environmental Quality Act, the State CEQA Guidelines, and the County's "Rules and Regulations to Implement CEQA as amended".
2. That the County has reviewed, analyzed, and considered Final Project EIR, the environmental impacts therein identified for this Project, the Candidate CEQA Findings, and the Mitigation Monitoring and Reporting Program, and the entire Record of Proceedings prior to approving this project.

3. That the Mitigation Monitoring and Reporting Program is designed to ensure that during project implementation, the Developer and any other responsible parties implement the Project components and comply with feasible mitigation measures identified in the CEQA Findings, the Project entitlements, and the Mitigation Monitoring and Reporting Program. That these measures are fully enforceable through permit conditions, agreements, and/or other measures, such as their inclusion in the Mitigation Monitoring and Reporting Program.

4. That the Project will not individually or cumulatively have an unmitigated adverse effect on fish and wildlife resources, as defined in Section 711.2 of the Fish and Game Code.

5. That the Record of Proceedings consists of the Final Project EIR (and all its technical reports and addendums thereto); the County staff reports; the CEQA Findings; the Mitigation Monitoring and Reporting Program; the various Project entitlements and documents referenced therein; all final reports, applications, memoranda, maps, letters, and other planning documents prepared by the EIR planning/environmental consultant. Additionally, all final reports, memoranda, maps, letters, and other planning documents prepared by the County staff; all documents submitted by members of the public and public agencies in connection with the Final Project EIR; minutes and transcripts of all public meetings and public hearings; all written and verbal public testimony presented during a noticed public hearing for the proposed project which such testimony was taken and any and all other materials which constitute the record of proceeding pursuant to Public Resources Code section 21167.6(e); and matters of common knowledge to the County staff, Board of Supervisors, including, but not limited to the County General Plan, the County Zoning Ordinance, County policies, which may be found at the Clerk's Office located at 940 Main Street, Suite 209, El Centro, CA, 92243 during regular business hours, and the Imperial County Planning & Development Services Department at 801 Main Street, El Centro, CA 92243.

NOW, THEREFORE, based on the above findings, the **IMPERIAL COUNTY PLANNING BOARD OF SUPERVISORFS DOES APPROVE OF** the Mitigation Monitoring Reporting Program (MMRP),

Ryan E. Kelley, Chairman
Imperial County Board of Supervisors

I hereby certify that the preceding resolution was taken by the Board of Supervisors at a meeting conducted on October 24, 2023, by the following vote:

BOARD OF SUPERVISORS RESOLUTION FOR
MMRP
Page 3 of 3

AYES:

NOES:

ABSENT:

ABSTAIN:

ATTEST:

Blanca Acosta
Clerk of the Board of Supervisors

S:\APN\059\300\015\cup20-0020\BS\MMRP\resolutiondocx

0.4 Mitigation Monitoring and Reporting Program

The County of Imperial will adopt this Mitigation Monitoring and Reporting Program (MMRP) in accordance with Public Resources Code (PRC) Section 21081.6 and Section 15097 of the California Environmental Quality Act (CEQA) Guidelines. The purpose of the MMRP is to ensure that the VEGA SES 4 Solar Energy Project, which is the subject of the Environmental Impact Report (EIR), complies with all applicable environmental mitigation requirements. The mitigation measures for the project will be adopted by the County of Imperial, in conjunction with the certification of the Final EIR. The mitigation measures have been integrated into this MMRP.

The mitigation measures are provided in Table 0.4-1. The specific mitigation measures are identified, as well as the monitoring method, responsible monitoring party, monitoring phase, verification/approval party, date mitigation measure verified or implemented, location of documents (monitoring record), and completion requirement for each mitigation measure.

The mitigation measures applicable to the project include avoiding certain impacts altogether, minimizing impacts by limiting the degree or magnitude of the action and its implementation, and/or reducing or eliminating impacts over time by maintenance operations during the life of the action.

Public Resources Code Section 21081.6 requires the Lead Agency, for each project that is subject to CEQA, to monitor performance of the mitigation measures included in any environmental document to ensure that implementation does, in fact, take place. The County of Imperial is the designated CEQA lead agency for the Mitigation Monitoring and Reporting Program. The County of Imperial is responsible for review of all monitoring reports, enforcement actions, and document disposition as it relates to impacts within the County's jurisdiction. The County of Imperial will rely on information provided by the monitor as accurate and up to date and will field check mitigation measure status as required.

A record of the MMRP will be maintained at County of Imperial, Department of Planning and Development Services, 801 Main Street, El Centro, CA 92243. All mitigation measures contained in the EIR shall be made conditions of the project as may be further described below.

This page is intentionally blank.



Table 0.4-1. Mitigation Measures

MM No.	Mitigation Measure	Monitoring Method	Responsible Monitoring Party	Monitoring Phase	Verification/Approval Party	Date Mitigation Measure Verified or Implemented	Location of Documents (Monitoring Record)	Completion Requirement
Agricultural Resources								
AG-1	<p>Pest Management Plan. Prior to the issuance of a grading permit or building permit (whichever occurs first), a Pest Management Plan shall be developed by the project applicant and approved by the County of Imperial Agricultural Commissioner. The project applicant shall maintain a Pest Management Plan until reclamation is complete. The plan shall provide the following:</p> <ol style="list-style-type: none"> 1. Monitoring, preventative, and management strategies for weed and pest control during construction activities at any portion of the project (e.g., transmission line); 2. Control and management of weeds and pests in areas temporarily disturbed during construction where native seed will aid in site revegetation as follows: <ul style="list-style-type: none"> • Monitor for all pests including insects, vertebrates, weeds, and pathogens. Promptly control or eradicate pests when found, or when notified by the Agricultural Commissioner's office that a pest problem is present on the project site. The assistance of a licensed pest control advisor is recommended. All treatments must be performed by a qualified applicator or a licensed pest control business; • All treatments must be performed by a qualified applicator or a licensed pest control operator; • "Control" means to reduce the population of common pests below economically damaging levels, and includes attempts to exclude pests before infestation, and effective control methods after infestation. Effective control methods may include physical/mechanical removal, bio control, cultural control, or chemical treatments; • Use of "permanent" soil sterilants to control weeds or other pests is prohibited because this would interfere with reclamation; 	<p>The Department of Planning and Development Services shall verify that a Pest Management Plan has been reviewed and approved by the Imperial County Agricultural Commissioner.</p>	<p>Department of Planning and Development Services and Imperial County Agricultural Commissioner</p>	<p>Prior to the issuance of a grading permit or building permit, during construction</p>	<p>Department of Planning and Development Services and Imperial County Agricultural Commissioner</p>			

Table 0.4-1. Mitigation Measures

MM No.	Mitigation Measure	Monitoring Method	Responsible Monitoring Party	Monitoring Phase	Verification/Approval Party	Date Mitigation Measure Verified or Implemented	Location of Documents (Monitoring Record)	Completion Requirement
	<ul style="list-style-type: none"> Notify the Agricultural Commissioner's office immediately regarding any suspected exotic/invasive pest species as defined by the California Department of Food Agriculture and the U.S. Department of Agriculture. Request a sample be taken by the Agricultural Commissioner's Office of a suspected invasive species. Eradication of exotic pests shall be done under the direction of the Agricultural Commissioner's Office and/or California Department of Food and Agriculture; Obey all pesticide use laws, regulations, and permit conditions; Allow access by Agricultural Commissioner staff for routine visual and trap pest surveys, compliance inspections, eradication of exotic pests, and other official duties; Ensure all project employees that handle pest control issues are appropriately trained and certified, all required records are maintained and made available for inspection, and all required permits and other required legal documents are current; Maintain records of pests found and treatments or pest management methods used. Records should include the date, location/block, project name (current and previous, if changed), and methods used. For pesticides include the chemical(s) used, EPA Registration numbers, application rates, etc. A pesticide use report may be used for this; Submit a report of monitoring, pest finds, and treatments, or other pest management methods to the Agricultural Commissioner quarterly within 15 days after the end of the previous quarter, and upon request. The report is required even if no pests were found or treatment occurred. It may consist of a copy of all records for the previous quarter, or may be a summary letter/report as long as the original detailed records are available upon request. 							

Table 0.4-1. Mitigation Measures

MM No.	Mitigation Measure	Monitoring Method	Responsible Monitoring Party	Monitoring Phase	Verification/Approval Party	Date Mitigation Measure Verified or Implemented	Location of Documents (Monitoring Record)	Completion Requirement
	<p>3. A long-term strategy for weed and pest control and management during the operation of the proposed projects. Such strategies may include, but are not limited to:</p> <ul style="list-style-type: none"> • Use of specific types of herbicides and pesticides on a scheduled basis. <p>4. Maintenance and management of project site conditions to reduce the potential for a significant increase in pest-related nuisance conditions on surrounding agricultural lands.</p> <p>5. The project shall reimburse the Agricultural Commissioner's office for the actual cost of investigations, inspections, or other required non-routine responses to the site that are not funded by other sources.</p>							

Air Quality

AQ-1	<p>Fugitive Dust Control. During construction activities, the contractor/contractor shall employ the following PM₁₀ reducing measures:</p> <p>1. All unpaved roads associated with construction shall be effectively stabilized of dust emissions using Imperial County Air Pollution Control District-approved chemical stabilizers/suppressant before the commencement of construction, and every 30 days thereafter until the end of all construction activities. Unpaved roads associated with construction include:</p> <ul style="list-style-type: none"> • The driveway entrance off State Route 98; • The project designated 3.5-acre staging/parking area north of the All-American Canal; • The 1.0 mile of dirt road south of the All-American Canal; and • The 20 miles of existing dirt road paralleling the U.S./Mexico Border from Gordon Wells Road to the project site. <p>Monthly application of Imperial County Air Pollution Control District-approved chemical stabilizers/suppressant shall be applied at a rate of 0.1 gallon/square yard of chemical dust suppressant.</p>	<p>Prior to and during construction, the ICAPCD will verify that the project is in compliance with the fugitive dust control measures as identified in Mitigation Measure AQ-1 and Regulation VIII-Fugitive Dust Control Measures.</p>	<p>Department of Planning and Development Services and ICAPCD</p>	<p>Prior to and during construction</p>	<p>Department of Planning and Development Services and ICAPCD</p>			
------	----------------------------------------------------------------------------------------------------------------------------------------------------------------------------------------------------------------------------------------------------------------------------------------------------------------------------------------------------------------------------------------------------------------------------------------------------------------------------------------------------------------------------------------------------------------------------------------------------------------------------------------------------------------------------------------------------------------------------------------------------------------------------------------------------------------------------------------------------------------------------------------------------------------------------------------------------------------------------------------------------------------------------------------------------------------------------------------------------------------------------------------------------------------	----------------------------------------------------------------------------------------------------------------------------------------------------------------------------------------------------------------------------------------	-------------------------------------------------------------------	-----------------------------------------	-------------------------------------------------------------------	--	--	--

Table 0.4-1. Mitigation Measures

MM No.	Mitigation Measure	Monitoring Method	Responsible Monitoring Party	Monitoring Phase	Verification/Approval Party	Date Mitigation Measure Verified or Implemented	Location of Documents (Monitoring Record)	Completion Requirement
	<p>2. Prior to any earthmoving activity, the applicant shall submit a construction dust control plan and obtain Imperial County Air Pollution Control District and Imperial County Planning and Development Services Department (ICPDS) approval.</p> <p>3. Pursuant to ICAPCD, all construction sites, regardless of size, must comply with the requirements contained within Regulation VIII – Fugitive Dust Control Measures. Whereas these Regulation VIII measures are mandatory and are not considered project environmental mitigation measures, the ICAPCD CEQA Handbook's required additional standard and enhanced mitigation measures listed below shall be implemented prior to and during construction. ICAPCD will verify implementation and compliance with these measures as part of the grading permit review/approval process.</p> <p>ICAPCD Standard Measures for Fugitive Dust (PM₁₀) Control</p> <ul style="list-style-type: none"> All disturbed areas, including bulk material storage, which is not being actively utilized, shall be effectively stabilized and visible emissions shall be limited to no greater than 20 percent opacity for dust emissions by using water, chemical stabilizers, dust suppressants, tarps, or other suitable material, such as vegetative ground cover. All on-site and offsite unpaved roads will be effectively stabilized and visible emissions shall be limited to no greater than 20 percent opacity for dust emissions by paving, chemical stabilizers, dust suppressants, and/or watering. All unpaved traffic areas 1 acre or more with 75 or more average vehicle trips per day will be effectively stabilized and visible emissions shall be limited to no greater than 20 percent opacity for dust emissions by paving, chemical stabilizers, dust suppressants, and/or watering. The transport of bulk materials shall be completely covered unless 6 inches of freeboard space from the top of the container is maintained with no spillage and loss of bulk material. In 							

Table 0.4-1. Mitigation Measures

MM No.	Mitigation Measure	Monitoring Method	Responsible Monitoring Party	Monitoring Phase	Verification/Approval Party	Date Mitigation Measure Verified or Implemented	Location of Documents (Monitoring Record)	Completion Requirement
	<p>addition, the cargo compartment of all haul trucks is to be cleaned and/or washed at delivery site after removal of bulk material.</p> <ul style="list-style-type: none"> All track-out or carry-out will be cleaned at the end of each workday or immediately when mud or dirt extends a cumulative distance of 50 linear feet or more onto a paved road within an urban area. Movement of bulk material handling or transfer shall be stabilized prior to handling or at points of transfer with application of sufficient water, chemical stabilizers, or by sheltering or enclosing the operation and transfer line. The construction of any new unpaved road is prohibited within any area with a population of 500 or more unless the road meets the definition of a temporary unpaved road. Any temporary unpaved road shall be effectively stabilized and visible emissions shall be limited to no greater than 20 percent opacity for dust emission by paving, chemical stabilizers, dust suppressants, and/or watering. <p>ICAPCD "Discretionary" Measures for Fugitive Dust (PM₁₀) Control</p> <ul style="list-style-type: none"> Water exposed soil only in those areas where active grading and vehicle movement occurs with adequate frequency to control dust. Replace ground cover in disturbed areas as quickly as possible. Automatic sprinkler system installed on all soil piles. Vehicle speed for all construction vehicles shall not exceed 15 miles per hour on any unpaved surface at the construction site. Develop a trip reduction plan to achieve a 1.5 average vehicle ridership for construction employees. Implement a shuttle service to and from retail services and food establishments during lunch hours. <p>Standard Mitigation Measures for Construction Combustion Equipment</p>							

Table 0.4-1. Mitigation Measures

MM No.	Mitigation Measure	Monitoring Method	Responsible Monitoring Party	Monitoring Phase	Verification/Approval Party	Date Mitigation Measure Verified or Implemented	Location of Documents (Monitoring Record)	Completion Requirement
	<ul style="list-style-type: none"> Use of alternative fueled or catalyst equipped diesel construction equipment, including all off-road and portable diesel-powered equipment. Minimize idling time either by shutting equipment off when not in use or reducing the time of idling to 5 minutes as a maximum. Limit, to the extent feasible, the hours of operation of heavy-duty equipment and/or the amount of equipment in use. Replace fossil fueled equipment with electrically driven equivalents (provided they are not run via a portable generator set). <p>Enhanced Mitigation Measures for Construction Equipment</p> <p>To help provide a greater degree of reduction of PM emissions from construction combustion equipment, ICAPCD recommends the following enhanced measures:</p> <ul style="list-style-type: none"> Curtail construction during periods of high ambient pollutant concentrations; this may include ceasing of construction activity during the peak hour of vehicular traffic on adjacent roadways. Implement activity management (e.g., rescheduling activities to reduce short-term impacts). 							
AQ-2	<p>Construction Equipment. Construction equipment shall be equipped with an engine designation of EPA Tier 2 or better (Tier 2+). A list of the construction equipment, including all off-road equipment utilized at the project site by make, model, year, horsepower and expected/factual hours of use, and the associated EPA Tier shall be submitted to the County Planning and Development Services Department and ICAPCD prior to the issuance of a grading permit. The equipment list shall be submitted periodically to ICAPCD to perform a NOx analysis. ICAPCD shall utilize this list to calculate air emissions to verify that equipment use does not exceed significance thresholds. The Planning and Development Services Department and ICAPCD shall verify implementation of this measure.</p>	<p>Prior to the issuance of a grading permit, ICAPCD shall verify that construction equipment is equipped with an engine designation of EPA Tier 2 or better.</p> <p>The equipment list shall be submitted periodically to ICAPCD to perform a NOx analysis.</p>	Department of Planning and Development Services and ICAPCD	Prior to the issuance of a grading permit and during construction	Department of Planning and Development Services and ICAPCD			

Table 0.4-1. Mitigation Measures

MM No.	Mitigation Measure	Monitoring Method	Responsible Monitoring Party	Monitoring Phase	Verification/Approval Party	Date Mitigation Measure Verified or Implemented	Location of Documents (Monitoring Record)	Completion Requirement
AQ-3	Dust Suppression. The project applicant shall employ a method of dust suppression (such as water or chemical stabilization) approved by ICAPCD. The project applicant shall apply chemical stabilization as directed by the product manufacturer to control dust between the panels as approved by ICAPCD, and other non-used areas (exceptions will be the paved entrance and parking area, and Fire Department access/emergency entry/exit points as approved by Fire/ Office of Emergency Services [OES] Department).	During construction, the Department of Planning and Development Services shall verify that the project applicant is employing a method of dust suppression approved by ICAPCD.	Department of Planning and Development Services	During construction	Department of Planning and Development Services			
AQ-4	Operational Dust Control Plan. Prior to issuance of a Certificate of Occupancy, the applicant shall submit an operations dust control plan and obtain ICAPCD and ICPDS approval. ICAPCD Rule 301 Operational Fees apply to any project applying for a building permit. At the time that building permits are submitted for the proposed project, the ICAPCD shall review the project to determine if Rule 310 fees are applicable to the project.	Prior to the issuance of a Certificate of Occupancy, the applicant shall submit an operations dust control plan and obtain ICAPCD and ICPDS approval.	Department of Planning and Development Services	Prior to the issuance of a Certificate of Occupancy	Department of Planning and Development Services and ICAPCD			
Biological Resources								
BIO-1	Rare Plant Surveys. Prior to initiating ground disturbance, rare plant surveys shall be conducted within suitable habitat on the project site during the appropriate blooming period for the Abrams' spurge (approximately September through November), Wiggins' croton (approximately March through May), and sand food (approximately April through June). The surveys shall be conducted by a botanist or qualified biologist in accordance with the USFWS Guidelines for Conducting and Reporting Botanical Inventories for Federally Listed, Proposed, and Candidate Plants (USFWS 1996); the CDFW Protocols for Surveying and Evaluating Impacts to Special Status Native Plant Populations and Sensitive Natural Communities (CDFW 2018); and the CNPS Botanical Survey Guidelines (CNPS 2001). If any special-status species are observed during the rare plant surveys, the location of the individual plant or population will be recorded with a submeter GPS device for mapping purposes. If project-related impacts to rare plants on the project site are unavoidable, then consultation with CDFW may be required to develop a mitigation plan or additional	Prior to initiating ground disturbance, the Department of Planning and Development Services shall verify that rare plant surveys have been conducted on the project site.	Department of Planning and Development Services	Prior to construction	Department of Planning and Development Services			

Table 0.4-1. Mitigation Measures

MM No.	Mitigation Measure	Monitoring Method	Responsible Monitoring Party	Monitoring Phase	Verification/Approval Party	Date Mitigation Measure Verified or Implemented	Location of Documents (Monitoring Record)	Completion Requirement
BIO-2	<p>avoidance and minimization measures. Mitigation measures that may be implemented if the species is observed include establishing a no-disturbance buffer around locations of individuals or a population, salvage or seed collection, and additional monitoring requirements.</p> <p>General Impact Avoidance and Minimization Measures. The following measures will be applicable throughout the life of the project:</p> <ul style="list-style-type: none"> To reduce the potential indirect impact on migratory birds, bats and raptors, the project will comply with the APLIC 2012 Guidelines for overhead utilities, as appropriate, to minimize avian collisions with transmission facilities (APLIC 2012). All electrical components on the project site shall be either undergrounded or protected so that there will be no exposure to wildlife and therefore no potential for electrocution. The project proponent shall designate a Project Biologist who shall be responsible for overseeing compliance with protective measures for the biological resources during vegetation clearing and work activities within and adjacent to areas of native habitat. The Project Biologist will be familiar with the local habitats, plants, and wildlife. The Project Biologist will also maintain communications with the Contractor to ensure that issues relating to biological resources are appropriately and lawfully managed and monitor construction. The Project Biologist will monitor activities within construction areas during critical times, such as vegetation removal, the implementation of Best Management Practices (BMP), and installation of security fencing to protect native species. The Project Biologist will ensure that all wildlife and regulatory agency permit requirements, conservation measures, and general avoidance and minimization measures are properly implemented and followed. The boundaries of all areas to be newly disturbed (including solar facility areas, staging areas, access roads, and sites for temporary placement of construction materials and spoils) will be 	The measures as provided in Mitigation Measure BIO-2 shall be implemented throughout the life of the project.	Department of Planning and Development Services	Prior to construction, during construction, and post-construction	Department of Planning and Development Services			

Table 0.4-1. Mitigation Measures

MM No.	Mitigation Measure	Monitoring Method	Responsible Monitoring Party	Monitoring Phase	Verification/Approval Party	Date Mitigation Measure Verified or Implemented	Location of Documents (Monitoring Record)	Completion Requirement
	<p>delineated with stakes and flagging prior to disturbance. All disturbances, vehicles, and equipment will be confined to the flagged areas.</p> <ul style="list-style-type: none"> No potential wildlife entrapments (e.g., trenches, bores) will be left uncovered overnight. Any uncovered pitfalls will be excavated to 3:1 slopes at the ends to provide wildlife escape ramps. Alternatively, man-made ramps may be installed. Covered pitfalls will be covered completely to prevent access by small mammals or reptiles. To avoid wildlife entrapment (including birds), all pipes or other construction materials or supplies will be covered or capped in storage or laydown area, and at the end of each work day in construction, quarrying and processing/handling areas. No pipes or tubing of sizes or inside diameters ranging from 1 to 10 inches will be left open either temporarily or permanently. No anticoagulant rodenticides, such as Warfarin and related compounds (indandiones and hydroxycoumarins), may be used within the project site, on off-site project facilities and activities, or in support of any other project activities. Avoid wildlife attractants. All trash and food-related waste shall be placed in self-closing containers and removed regularly from the site to prevent overflow. Workers shall not feed wildlife. Water applied to dirt roads and construction areas for dust abatement shall use the minimal amount needed to meet safety and air quality standards to prevent the formation of puddles, which could attract wildlife. Pooled rainwater or floodwater within retention basins will be removed to avoid attracting wildlife to the active work areas. To minimize the likelihood for vehicle strikes on wildlife, speed limits will not exceed 15 miles per hour when driving on access roads. All vehicles required for O&M must remain on designated access/maintenance roads. Avoid night-time construction lighting or if nighttime construction cannot be avoided use shielded directional lighting pointed downward and towards the interior of the project site. 							

Table 0.4-1. Mitigation Measures

MM No.	Mitigation Measure	Monitoring Method	Responsible Monitoring Party	Monitoring Phase	Verification/Approval Party	Date Mitigation Measure Verified or Implemented	Location of Documents (Monitoring Record)	Completion Requirement
	<p>thereby avoiding illumination of adjacent natural areas and the night sky.</p> <ul style="list-style-type: none"> All construction equipment used for the project will be equipped with properly operating and maintained mufflers. Hazardous materials and equipment stored overnight, including small amounts of fuel to refuel hand-held equipment, will be stored within secondary containment when within 50 feet of open water to the fullest extent practicable. Secondary containment will consist of a ring of sand bags around each piece of stored equipment/structure. A plastic tarp/visqueen lining with no seams shall be placed under the equipment and over the edges of the sandbags, or a plastic hazardous materials secondary containment unit shall be utilized by the Contractor. The Contractor will be required to conduct vehicle refueling in upland areas where fuel cannot enter waters of the U.S. and in areas that do not have potential to support federally threatened or endangered species. Any fuel containers, repair materials, including creosote-treated wood, and/or stockpiled material that is left on site overnight will be secured in secondary containment within the work area and staging/assembly area and covered with plastic at the end of each work day. In the event that no activity is to occur in the work area for the weekend and/or a period of time greater than 48 hours, the Contractor will ensure that all portable fuel containers are removed from the project site. All equipment will be maintained in accordance with manufacturer's recommendations and requirements. Equipment and containers will be inspected daily for leaks. Should a leak occur, contaminated soils and surfaces will be cleaned up and disposed of following the guidelines identified in the Stormwater Pollution Prevention Plan or equivalent, Materials Safety Data Sheets, and any specifications required by other permits issued for the project. 							

Table 0.4-1. Mitigation Measures

MM No.	Mitigation Measure	Monitoring Method	Responsible Monitoring Party	Monitoring Phase	Verification/Approval Party	Date Mitigation Measure Verified or Implemented	Location of Documents (Monitoring Record)	Completion Requirement
	<ul style="list-style-type: none"> • The Contractor will utilize off-site maintenance and repair shops as much as possible for maintenance and repair of equipment. • If maintenance of equipment must occur onsite, fuel/oil pans, absorbent pads, or appropriate containment will be used to capture spills/leaks within all areas. Where feasible, maintenance of equipment will occur in upland areas where fuel cannot enter waters of the U.S. and in areas that do not have potential to support federally threatened or endangered species. • Appropriate BMPs will be used by the Contractor to control erosion and sedimentation and to capture debris and contaminants from bridge construction to prevent their deposition in waterways. No sediment or debris will be allowed to enter the creek or other drainages. All debris from construction of the bridge will be contained so that it does not fall into channel. Appropriate BMPs will be used by the Contractor during construction to limit the spread of resuspended sediment and to contain debris. • Erosion and sediment control devices used for the proposed project, including fiber rolls and bonded fiber matrix, will be made from biodegradable materials such as jute, with no plastic mesh, to avoid creating a wildlife entanglement hazard. • Firearms, open fires, and pets would be prohibited at all work locations and access roads. Smoking would be prohibited along the project alignment. • Cross-country vehicle and equipment use outside of approved designated work areas and access roads shall be prohibited to prevent unnecessary ground and vegetation disturbance. • Any injured or dead wildlife encountered during project-related activities shall be reported to the project biologist, biological monitor, CDFW, or a CDFW-approved veterinary facility as soon as possible to report the observation and determine the best course of action. For special-status species, the Project Biologist shall notify the 							

Table 0.4-1. Mitigation Measures

MM No.	Mitigation Measure	Monitoring Method	Responsible Monitoring Party	Monitoring Phase	Verification/Approval Party	Date Mitigation Measure Verified or Implemented	Location of Documents (Monitoring Record)	Completion Requirement
	<p>County, USFWS, and/or CDFW, as appropriate, within 24 hours of the discovery.</p> <ul style="list-style-type: none"> • Stockpiling of material will be allowed only within established work areas. • Actively manage the spread of noxious weeds • The ground beneath all parked equipment and vehicles shall be inspected for wildlife before moving. 							
BIO-3	<p>Worker Environmental Awareness Program. Prior to project construction, a Worker Environmental Awareness Program shall be developed and implemented by a qualified biologist, and shall be available in both English and Spanish. Handouts summarizing potential impacts to special-status biological resources and the potential penalties for impacts to these resources shall be provided to all construction personnel. At a minimum, the education program shall include the following:</p> <ul style="list-style-type: none"> • the purpose for resource protection; • a description of special-status species including representative photographs and general ecology; • occurrences of USACE, RWQCB, and CDFW regulated features in the project survey area; • regulatory framework for biological resource protection and consequences if violated; • sensitivity of the species to human activities; • avoidance and minimization measures designed to reduce the impacts to special-status biological resources; • environmentally responsible construction practices; • reporting requirements; • the protocol to resolve conflicts that may arise at any time during the construction process; and • workers sign acknowledgement form indicating that the Environmental Awareness Training and Education Program that has been completed and would be kept on record. 	<p>Prior to construction, the Department of Planning and Development Services shall verify that a Worker Environmental Awareness Program has been implemented by a qualified biologist. The Department of Planning and Development Services shall verify the completion of the Worker Environmental Awareness Program by obtaining signed acknowledgements forms from workers.</p>	Department of Planning and Development Services	Prior to construction	Department of Planning and Development Services			



Table 0.4-1. Mitigation Measures

MM No.	Mitigation Measure	Monitoring Method	Responsible Monitoring Party	Monitoring Phase	Verification/Approval Party	Date Mitigation Measure Verified or Implemented	Location of Documents (Monitoring Record)	Completion Requirement
BIO-4	<p>Burrowing Owl Avoidance and Minimization. Take Avoidance (pre-construction) surveys for burrowing owl shall be completed prior to project construction. Surveys shall be conducted as detailed within Appendix D of the Staff Report on Burrowing Owl Mitigation (California Department of Fish and Game [CDFG] 2012). If burrowing owl is not detected, construction may proceed.</p> <ul style="list-style-type: none"> If burrowing owl is identified during the non-breeding season (September 1 through January 31), then a 50-meter buffer will be established by the biological monitor. Construction within the buffer will be avoided until a qualified biologist determines that burrowing owl is no longer present or until a CDFW-approved exclusion plan has been implemented. The buffer distance may be reduced if noise attenuation buffers such as hay bales are placed between the occupied burrow and construction activities. If burrowing owl is identified during the breeding season (February 1 through August 31), then an appropriate buffer will be established by the biological monitor in accordance with the Staff Report on Burrowing Owl Mitigation (CDFG 2012). Construction within the buffer will be avoided until a qualified biologist determines that burrowing owl is no longer present or until young have fledged. The buffer distance may be reduced in consultation with CDFW if noise attenuation buffers such as hay bales are placed between the occupied burrow and construction activities. 	<p>Prior to construction, the Department of Planning and Development Services shall verify that pre-construction surveys for burrowing owl were conducted. If burrowing owls are present, the measures as listed in Mitigation Measure BIO-4 shall be implemented.</p>	Department of Planning and Development Services	Prior to construction, during construction	Department of Planning and Development Services			
BIO-5	<p>Pre-Construction Nesting Bird Surveys. If construction or other project activities are scheduled to occur during the bird breeding season (typically February 1 through August 31 for raptors and March 15 through August 31 for the majority of migratory bird species), a pre-construction nesting-bird survey shall be conducted by a qualified avian biologist to ensure that active bird nests, including those for the northern harrier, yellow warbler, burrowing owl, and loggerhead shrike, will not be disturbed or destroyed. The survey shall be completed no more than three days prior to initial ground disturbance. The nesting-bird survey shall include the project site and adjacent areas where</p>	<p>Prior to construction, the Department of Planning and Development Services shall verify that a pre-construction nesting bird survey was conducted if project activities are scheduled during the bird breeding season (typically February 1 through August 31 for raptors and March 15 through August 31 for the majority of migratory bird species), if nesting birds are present.</p>	Department of Planning and Development Services	Prior to construction, during construction	Department of Planning and Development Services			

Table 0.4-1. Mitigation Measures

MM No.	Mitigation Measure	Monitoring Method	Responsible Monitoring Party	Monitoring Phase	Verification/Approval Party	Date Mitigation Measure Verified or Implemented	Location of Documents (Monitoring Record)	Completion Requirement
	<p>project activities have the potential to affect active nests, either directly or indirectly due to construction activity or noise. If an active nest is identified, the biologist shall establish an appropriately sized disturbance-limit buffer around the nest using flagging or staking. Construction activities shall not occur within any disturbance-limit buffer zones until the nest is deemed inactive by the qualified biologist. If construction activities cease for a period of greater than three days during the bird breeding season, a pre-construction nesting bird survey shall be conducted prior to the commencement of activities. Final construction buffers or setback distances shall be determined by the qualified biologist in coordination with USFWS and CDFW on a case-by-case basis, depending on the species, season in which disturbance shall occur, the type of disturbance, and other factors that could influence susceptibility to disturbance (e.g., topography, vegetation, existing disturbance levels, etc.)</p>	<p>the measures as listed in Mitigation Measure BIO-5 shall be implemented.</p>						
BIO-6	<p>Pre-Construction Survey for Special-Status Species. A pre-construction survey shall be conducted for special-status wildlife species within all areas of potential permanent and temporary disturbance. The pre-construction survey shall take place no more than 14 days prior to the start of ground-disturbing activities. The pre-construction surveys should take place regardless of breeding season timing and shall focus on identifying the presence of special-status wildlife species present on the project site or that were identified as having a high potential to occur on the site. These species include, but are not limited to, flat-tailed horned lizard, burrowing owl, northern harrier, and yellow warbler. Should any special-status species be identified during the pre-construction survey, consultation to develop suitable avoidance and minimization measures with the appropriate agency (USFWS, CDFW) may need to be undertaken.</p>	<p>Prior to construction, the Department of Planning and Development Services shall verify that a pre-construction survey for special-status species was conducted.</p>	<p>Department of Planning and Development Services</p>	<p>Prior to construction</p>	<p>Department of Planning and Development Services</p>			
BIO-7	<p>Bat Acoustic Surveys and Monitoring. To avoid impacts to bat species, a qualified bat biologist shall conduct an appropriate combination of sampling, exit counts, and acoustic surveys to determine if bats are using the palm tree resources in the project area. If project-related impacts to bat species are unavoidable, additional measures may need to be</p>	<p>Prior to construction, the Department of Planning and Development Services shall verify that bat acoustic surveys have been conducted.</p>	<p>Department of Planning and Development Services</p>	<p>Prior to construction, during construction</p>	<p>Department of Planning and Development Services</p>			

Table 0.4-1. Mitigation Measures

MM No.	Mitigation Measure	Monitoring Method	Responsible Monitoring Party	Monitoring Phase	Verification/Approval Party	Date Mitigation Measure Verified or Implemented	Location of Documents (Monitoring Record)	Completion Requirement
	implemented to reduce or eliminate impacts to bat species, including maternity roosts, such as tree removal occurring outside of bat breeding season (October through February) or two-step, two-day removal of palm trees under supervision of a qualified bat biologist.							
Cultural Resources								
CR-1	Environmentally Sensitive Area Fencing. Prior to issuance of grading permits and in coordination with a qualified archaeologist to be retained by the project applicant, the construction zone shall be narrowed or otherwise altered to avoid Sites 2020-142-001, 2020-142-002, 2020-142-004, 2020-142-005, and 2020-142-008. The area within 100 feet of Sites 2020-142-001, 2020-142-002, 2020-142-004, 2020-142-005, and 2020-142-008 shall be designated Environmentally Sensitive Area (ESA) and fenced or flagged with exclusion markers to ensure avoidance. Protective fencing shall not identify the protected area as a cultural resource area in order to discourage unauthorized disturbance or collection of artifacts. The ESA fencing or flags shall remain in place throughout project construction.	Prior to issuance of grading permits, the Department of Planning and Development Services shall verify the following:	Department of Planning and Development Services	Prior to grading	Department of Planning and Development Services			
		<ol style="list-style-type: none"> The construction zone was narrowed or otherwise altered to avoid Sites 2020-142-001, 2020-142-002, 2020-142-004, 2020-142-005, and 2020-142-008. The area within 100 feet of Sites 2020-142-001, 2020-142-002, 2020-142-004, 2020-142-005, and 2020-142-008 has been designated Environmentally Sensitive Area (ESA) and fenced or flagged with exclusion markers to ensure avoidance. 						
CR-2	Evaluate Significance of Find (Unknown Cultural Resources). If subsurface deposits believed to be cultural in origin are discovered during construction, all work must halt within a 100-foot radius of the discovery. A qualified professional archaeologist who meets the Secretary of the Interior's Standards for prehistoric and historic archaeology and is familiar with the resources of the region, shall be retained to evaluate the significance of the find, and shall have the authority to modify the no work radius as appropriate, using professional judgment. The following notifications shall apply, depending on the nature of the find:	The Department of Planning and Development Services shall verify that the project applicant has retained a qualified professional archaeologist. If the professional archaeologist determines that the find does represent a cultural resource, work may not resume within the no-work radius until the Imperial County Planning and	Department of Planning and Development Services	During grading and construction	Department of Planning and Development Services			

Table 0.4-1. Mitigation Measures

MM No.	Mitigation Measure	Monitoring Method	Responsible Monitoring Party	Monitoring Phase	Verification/Approval Party	Date Mitigation Measure Verified or Implemented	Location of Documents (Monitoring Record)	Completion Requirement
	<ul style="list-style-type: none"> If the professional archaeologist determines that the find does not represent a cultural resource, work may resume immediately, and no agency notifications are required. If the professional archaeologist determines that the find does represent a cultural resource from any time period or cultural affiliation, he or she shall immediately notify the Imperial County Planning and Development Services Department. The Imperial County Planning and Development Services Department shall consult with the professional archaeologist on a finding of eligibility and implement appropriate treatment measures if the find is determined to be an Historical Resource under CEQA, as defined in Section 15064.5(a) of the CEQA Guidelines, or an Historic Property, as defined in 36 CFR 60.4. Work may not resume within the no-work radius until the Imperial County Planning and Development Services Department, through consultation as appropriate, determine that the site either: 1) is not an Historical Resource under CEQA or an Historic Property under Section 106; or 2) that the treatment measures have been completed to their satisfaction. 	Development Services Department, through consultation as appropriate, determine that the site either: 1) is not an Historical Resource under CEQA or an Historic Property under Section 106; or 2) that the treatment measures have been completed to their satisfaction.						
CR-3	<p>Evaluate Significance of Find (Unknown Archaeological Resources). In the event of the discovery of previously unidentified archaeological materials, the contractor shall immediately cease all work activities within approximately 100 feet of the discovery. After cessation of excavation, the contractor shall immediately contact the Imperial County Department of Planning and Development Services Department. Except in the case of cultural items that fall within the scope of the Native American Grave Protection and Repatriation Act, the discovery of any cultural resource within the project area shall not be grounds for a "stop work" notice or otherwise interfere with the project's continuation except as set forth in this paragraph.</p> <p>In the event of an unanticipated discovery of archaeological materials during construction, the applicant shall retain the services of a qualified professional archaeologist, meeting the Secretary of</p>	If the qualified archaeologist determines that a discovery constitutes a significant resource under CEQA and it cannot be avoided, the Department of Planning and Development Services shall verify that an archaeological data recovery program has been conducted.	Department of Planning and Development Services	During grading and construction	Department of Planning and Development Services			



Table 0.4-1. Mitigation Measures

MM No.	Mitigation Measure	Monitoring Method	Responsible Monitoring Party	Monitoring Phase	Verification/Approval Party	Date Mitigation Measure Verified or Implemented	Location of Documents (Monitoring Record)	Completion Requirement
CR-4	<p>the Interior's Standards for a Qualified Archaeologist, to evaluate the significance of the materials prior to resuming any construction-related activities in the vicinity of the find. If the qualified archaeologist determines that the discovery constitutes a significant resource under CEQA and it cannot be avoided, the applicant shall implement an archaeological data recovery program.</p> <p>Human Remains. If subsurface deposits believed to be human in origin are discovered during construction, all work must halt within a 100-foot radius of the discovery. A qualified professional archaeologist who meets the Secretary of the Interior's Standards for prehistoric and historic archaeology and is familiar with the resources of the region, shall be retained to evaluate the significance of the find, and shall have the authority to modify the no work radius as appropriate, using professional judgment. The following notifications shall apply, depending on the nature of the find:</p> <ul style="list-style-type: none"> If the find includes human remains, or remains that are potentially human, the professional archaeologist shall ensure reasonable protection measures are taken to protect the discovery from disturbance (AB 2841). The archaeologist shall notify the Imperial County Coroner (per § 7050.5 of the Health and Safety Code). The provisions of § 7050.5 of the California Health and Safety Code, § 5097.98 of the California PRC, and AB 2841 will be implemented. If the Coroner determines the remains are Native American and not the result of a crime scene, the Coroner will notify the NAHC, which then will designate a Native American Most Likely Descendant (MLD) for the project (§ 5097.98 of the PRC). The designated MLD will have 48 hours from the time access to the property is granted to make recommendations concerning treatment of the remains. If the landowner does not agree with the recommendations of the MLD, the NAHC may mediate (§ 5097.94 of the PRC). If no agreement is reached, the landowner must rebury the remains where they will not be further disturbed (§ 5097.98 	<p>During grading and construction, discovery of human remains shall result in work stoppage in that area until the coroner and the Native American Heritage Commission are contacted.</p> <p>Work may not resume within the no-work radius until the Imperial County Planning and Development Services Department, through consultation as appropriate, determine that the treatment measures have been completed to their satisfaction.</p>	Department of Planning and Development Services	During grading and construction	Department of Planning and Development Services			

Table 0.4-1. Mitigation Measures

MM No.	Mitigation Measure	Monitoring Method	Responsible Monitoring Party	Monitoring Phase	Verification/Approval Party	Date Mitigation Measure Verified or Implemented	Location of Documents (Monitoring Record)	Completion Requirement
	<p>of the PRC) This will also include either recording the site with the NAHC or the appropriate Information Center; using an open space or conservation zoning designation or easement; or recording a right-of-way document with the county in which the property is located (AB 2641). Work may not resume within the no-work radius until the Imperial County Planning and Development Services Department, through consultation as appropriate, determines that the treatment measures have been completed to their satisfaction.</p>							

Table 0.4-1. Mitigation Measures

MM No.	Mitigation Measure	Monitoring Method	Responsible Monitoring Party	Monitoring Phase	Verification/Approval Party	Date Mitigation Measure Verified or Implemented	Location of Documents (Monitoring Record)	Completion Requirement
Geology and Soils								
GEO-1	<p>Prepare Geotechnical Report(s) as Part of Final Engineering for the Project and Implement Required Measures. Facility design for all project components shall comply with the site-specific design recommendations as provided by a licensed geotechnical or civil engineer to be retained by the project applicant. The final geotechnical and/or civil engineering report shall address and make recommendations on the following:</p> <ul style="list-style-type: none"> • Site preparation • Soil bearing capacity • Appropriate sources and types of fill • Potential need for soil amendments • Structural foundations • Grading practices • Soil corrosion of concrete and steel • Erosion/sedimentation • Seismic ground shaking • Liquefaction • Expansive/unstable soils <p>In addition to the recommendations for the conditions listed above, the geotechnical investigation shall include subsurface testing of soil and groundwater conditions, and shall determine appropriate foundation designs that are consistent with the version of the CBC that is applicable at the time building and grading permits are applied for. All recommendations contained in the final geotechnical engineering report shall be implemented by the project applicant. The final geotechnical and/or civil engineering report shall be submitted to Imperial County Public Works Department, Engineering Division for review and approval prior to issuance of building permits.</p>	<p>Prior to the issuance of a grading permit, the Imperial County Public Works Department, Engineering Division shall review and approve a Final Geotechnical Report and/or Civil Engineering Report.</p>	<p>Department of Planning and Development Services and Imperial County Public Works Department, Engineering Division</p>	<p>Prior to issuance of a grading permit</p>	<p>Department of Planning and Development Services and Imperial County Public Works Department, Engineering Division</p>			

Table 0.4-1. Mitigation Measures

MM No.	Mitigation Measure	Monitoring Method	Responsible Monitoring Party	Monitoring Phase	Verification/Approval Party	Date Mitigation Measure Verified or Implemented	Location of Documents (Monitoring Record)	Completion Requirement	
GEO-2	<p>Paleontological Resources. In the event that unanticipated paleontological resources or unique geologic resources are encountered during ground-disturbing activities, work must cease within 50 feet of the discovery and a paleontologist shall be hired to assess the scientific significance of the find. The consulting paleontologist shall have knowledge of local paleontology and the minimum levels of experience and expertise as defined by the <i>Society of Vertebrate Paleontology's Standard Procedures (2010) for the Assessment and Mitigation of Adverse Impacts to Paleontological Resources</i>. If any paleontological resources or unique geologic features are found within the project site, the consulting paleontologist shall prepare a paleontological Treatment and Monitoring Plan to include the methods that will be used to protect paleontological resources that may exist within the project site, as well as procedures for monitoring, fossil preparation and identification, curation of specimens into an accredited repository, and preparation of a report at the conclusion of the monitoring program.</p>	<p>During grading and construction, discovery of paleontological resources shall result in work stoppage in that area until the Qualified Paleontologist can determine the significance of the find.</p> <p>If any paleontological resources or unique geologic features are found within the project site, the project applicant shall submit a copy of a paleontological Treatment and Monitoring Plan.</p> <p>The project applicant shall submit a copy of the Paleontological Resources Monitoring Report to the Department of Planning and Development Services.</p>	Department of Planning and Development Services	Department of Planning and Development Services	During grading and post ground-disturbing activities	Department of Planning and Development Services			
Hydrology/Water Quality									
HYD-1	<p>Prepare SWPPP and Implement BMPs Prior to Construction and Site Restoration. The project applicant or its contractor shall prepare a SWPPP specific to the project and be responsible for securing coverage under SWRCB's NPDES stormwater permit for general construction activity (Order 2009-0009-DWC). The SWPPP shall identify specific actions and BMPs relating to the prevention of stormwater pollution from project-related construction sources by identifying a practical sequence for site restoration, BMP implementation, contingency measures, responsible parties, and agency contacts. The SWPPP shall reflect localized surface hydrological conditions and shall be reviewed and approved by the appropriate agency prior to commencement of work and shall be made conditions of the contract with the contractor selected to build and decommission the project. The SWPPP shall incorporate control measures in the following categories:</p>	<p>Prior to construction and site restoration, the project applicant or its contractor shall prepare a SWPPP with incorporated control measures as outlined in Mitigation Measure HYD-1; and implement BMPs. Department of Planning and Development Services to verify.</p>	Department of Planning and Development Services	Department of Planning and Development Services	Prior to issuance of a grading permit and site restoration	Department of Planning and Development Services			

Table 0.4-1. Mitigation Measures

MM No.	Mitigation Measure	Monitoring Method	Responsible Monitoring Party	Monitoring Phase	Verification/Approval Party	Date Mitigation Measure Verified or Implemented	Location of Documents (Monitoring Record)	Completion Requirement
	<ul style="list-style-type: none"> • Soil stabilization and erosion control practices (e.g., hydroseeding, erosion control blankets, mulching) • Sediment control practices (e.g., temporary sediment basins, fiber rolls) • Temporary and post-construction on- and off-site runoff controls • Special considerations and BMPs for water crossings and drainages • Monitoring protocols for discharge(s) and receiving waters, with emphasis place on the following water quality objectives: dissolved oxygen, floating material, oil and grease, potential of hydrogen (pH), and turbidity • Waste management, handling, and disposal control practices • Corrective action and spill contingency measures • Agency and responsible party contact information • Training procedures that shall be used to ensure that workers are aware of permit requirements and proper installation methods for BMPs specified in the SWPPP <p>The SWPPP shall be prepared by a Qualified SWPPP Practitioner and/or Qualified SWPPP Developer with BMPs selected to achieve maximum pollutant removal and that represent the best available technology that is economically achievable. Emphasis for BMPs shall be placed on controlling discharges of oxygen-depleting substances, floating material, oil and grease, acidic or caustic substances or compounds, and turbidity. BMPs for soil stabilization and erosion control practices and sediment control practices will also be required. Performance and effectiveness of these BMPs shall be determined either by visual means where applicable (i.e., observation of above-normal sediment release), or by actual water sampling in cases where verification of contaminant reduction or elimination, (inadvertent petroleum release) is required to determine adequacy of the measure.</p>							

Table 0.4-1. Mitigation Measures

MM No.	Mitigation Measure	Monitoring Method	Responsible Monitoring Party	Monitoring Phase	Verification/Approval Party	Date Mitigation Measure Verified or Implemented	Location of Documents (Monitoring Record)	Completion Requirement
HYD-2	<p>Incorporate Post-Construction Runoff BMPs Into Project Drainage Plan. The project Drainage Plan shall adhere to the County's Engineering Guidelines Manual, IID "Draft" Hydrology Manual, or other recognized source with approval by the County Engineer to control and manage the on- and off-site discharge of stormwater to existing drainage systems. Infiltration basins will be integrated into the Drainage Plan to the maximum extent practical. The Drainage Plan shall provide both short- and long-term drainage solutions to ensure the proper sequencing of drainage facilities and management of runoff generated from project impervious surfaces as necessary.</p> <p>The project's Final Drainage Plan shall adhere to the County's Engineering Guidelines Manual, IID "Draft" Hydrology Manual, or other recognized source with approval by the County Engineer to control and manage the on- and off-site discharge of stormwater to existing drainage systems. The Final Drainage Plan shall provide both short- and long-term drainage solutions to ensure the proper sequencing of drainage facilities and shall include source control and treatment BMPs to adequately treat collected runoff prior to discharge, as necessary.</p>	<p>Post construction, the applicant shall implement a Drainage Plan in accordance with the County and Imperial Irrigation District guidelines for the project site. Department of Planning and Development Services and IID to confirm.</p>	<p>Department of Planning and Development Services</p>	<p>Post construction</p>	<p>Department of Planning and Development Services and IID</p>			

Attachment E
CUP 20-0020

RESOLUTION NO.

A RESOLUTION OF THE BOARD OF SUPERVISORS OF THE COUNTY OF IMPERIAL, CALIFORNIA, FOR APPROVAL ON THE “VEGA SES 4 SOLAR ENERGY STORAGE PROJECT” FOR CONDITIONAL USE PERMIT #20-0020”

WHEREAS, APEX ENERGY SOLUTIONS, LLC has applied for Conditional Use Permit (CUP) #20-0020 to develop a nominal 100-megawatt (MW) solar photovoltaic (PV) energy generation project with an integrated battery storage system not to exceed 200 MW. The project includes a solar energy generation facility, battery storage system, switching station and gen-tie line. The project is to be located on approximately 450 acres; and,

WHEREAS, an Environmental Impact Report and CEQA Findings have been prepared in accordance with the requirements of the California Environmental Quality Act, the State Guidelines, and the County’s “Rules and Regulations to Implement CEQA,” as Amended; and,

WHEREAS, the Board of Supervisors of the County of Imperial has been delegated with the responsibility of approvals, and certifications for approvals of conditional use permits; and,

WHEREAS, public notice of said application has been given, and the Board of Supervisors has heard, received and considered all oral and written protests, objections and evidence presented by interested parties at a public hearing held with respect to this item on October 24, 2023; and

WHEREAS, the Draft EIR was received by the State Clearinghouse on November 22, 2022 and circulated for a period of 50 days (**SCH #2021050018**) with the commenting period ending January 10, 2023.

NOW, THEREFORE, the Board of Supervisors of the County of Imperial **DOES HEREBY RESOLVE** as follows:

SECTION 1. The Board of Supervisors has considered the proposed Conditional Use Permit #20-0020 with conditions of approval and recommendations prior to consideration for approval of the Project.

SECTION 2. That the Project complies with the requirements of the Imperial County Code and is in accordance with State Planning and Zoning law therefore, the following findings are made pursuant to Imperial County Code § 90203.09 as follows:

A. The proposed use is consistent with goals and policies of the adopted County General Plan. (Imperial County Code § 90203.09.A)

The current General Plan land use designations of the project site and proposed parcels are “Agriculture” and the proposed project parcels are within the Renewable Energy Overlay (RE). Therefore, the proposed uses could be found consistent with the General Plan.

B. The proposed use is consistent with the purpose of the zone or sub-zone within which the use will be used. (Imperial County Code § 90203.09.B)

The proposed project parcels are zoned A-3-RE. (General Agriculture with Renewable Energy Overlay). The proposed uses are consistent with the zone since they are listed as allowed uses under the A-3 RE zone with an approved Conditional Use Permit.

C. The proposed use is listed as a use within the zone or sub-zone or is found to be similar to a listed conditional use according to the procedures of Section 90203.00. (Imperial County Code § 90203.09.C)

The proposed use is consistent with the zone: A-3-RE (General Agriculture with Renewable Energy Overlay).

D. The proposed use meets the minimum requirements of this Title applicable to the use and complies with all applicable laws, ordinances and regulation of the County of Imperial and the State of California. (Imperial County Code § 90203.09.D)

The Project complies with the minimum requirements of this Title by, among other things, obtaining a CUP, complying with the California Environmental Quality Act, and participating in the public review and hearing process. Development standards have been established for the Project pursuant to these processes and will be enforced via imposition and enforcement of the Mitigation Monitoring and Reporting Program recommended for approval by separate Resolution, as well as the conditions of approval imposed on this CUP. The Conditions of Approval will further ensure that the project complies with all applicable regulations of the

County of Imperial and the State of California. Therefore, the proposed project meets the minimum requirements of the Land Use Ordinance, Section 90203.00.

E. The proposed use will not be detrimental to the health, safety, and welfare of the public or to the property and residents in the vicinity. (Imperial County Code § 90203.09.E)

The Environmental Impact Report (EIR) prepared for the Project analyzed the Project's potential effects on the health, safety, and welfare of the public and property and found that, with mitigation, the Project would have less than significant effects and impacts in all resource areas.

In addition, the project site is not near a residential community and is mostly surrounded by farmland and or open space/recreational land.

F. The proposed use does not violate any other law or ordinance. (Imperial County Code § 90203.09.F)

The proposed project will be subject to the Conditional Use Permit and current Federal, State and Local regulations. State Planning and Zoning Law (Cal. Govt. Code §§ 65000-66035) establishes minimum statewide standards for the regulation of local land use through planning and zoning. The County regulates local land use via Title 9 of the Imperial County Code. As found above, the proposed project is conditioned to be consistent with Imperial County, Title 9, Land Use Ordinance and CEQA mitigation measures and therefore complies with both State and local laws and ordinance.

Pursuant to CEQA, the County has prepared an EIR for the Project, which analyzes the proposed Project's compliance and consistency with other federal, state, and local laws and ordinances regulating the environment. Substantial evidence supports the conclusions in the EIR that the Project complies with said environmental laws, and thus the finds that the proposed use does not violate any other law or ordinance.

G. The proposed use is not granting a special privilege. (Imperial County Code § 90203.09.G)

The proposed solar generating and storage facility is a permitted use subject to approval of the proposed Conditional Use Permit. No special privileges are being offered or will be granted.

SECTION 3. Approval of the Project is conditioned upon the terms and conditions set forth in the Agreement for Conditional Use Permit #20-0020 attached hereto and incorporated herein by this reference.

NOW, THEREFORE, based on the above findings, the Imperial County Board of Supervisors **DOES HEREBY APPROVE** Conditional Use Permit #20-0020, subject to attached Conditions of Approval.

Ryan E. Kelley, Chairman
Imperial County Board of Supervisors

I hereby certify that the preceding resolution was taken by the Board of Supervisors at a meeting conducted on October 24, 2023 by the following vote:

AYES:

NOES:

ABSENT:

ABSTAIN:

ATTEST:

Blanca Acosta
Clerk of the Board of Supervisors

S:\AllUsers\APN\059 300 015\ cup20-0020\BS Folder\ cupResolution.docx

1 When Recorded Return To:

2 _____
3 Imperial County
4 Planning & Development Services
801 Main Street
El Centro, California 92243
5 _____

6
7 **AGREEMENT FOR CONDITIONAL USE PERMIT #20-0020**
8 **VEGA SES 4 SOLAR ENERGY STORAGE PROJECT**
9 **APN's 059-300-015 and 059-300-017-000**

10
11 This Agreement is made and entered into on this ___ day of _____, 2024, by and
12 between APEX ENERGY SOLUTIONS, LLC hereinafter referred to as the Permittee
13 (Permittee), and the COUNTY OF IMPERIAL, a political subdivision of the State of
14 California (County or Imperial County), related to the VEGA SES 4 SOLAR ENERGY
STORAGE PROJECT (CUP #20-0020) project area.

15 **RECITALS**

16 **WHEREAS**, Permittee is the lessee or successor-in-interest of certain land in
17 Imperial County to be improved with the proposed utility-scale solar and battery storage
18 facility. The project, Conditional Use Permit (CUP or Permit) #20-0020, consists of a
19 proposed 100-megawatt (MW) photovoltaic solar energy facility, energy (battery) storage
20 facility (up to 200 MW and not to exceed a 1 to 2 solar/battery ratio) and associated
21 infrastructure, including but not limited to, electrical switch station, substation, on-site
22 operations and maintenance (O&M), a gen-tie line and internal solar development
transmission lines, on approximately 450 acres within Imperial County (the "Project"). The
proposed facility is located south of the All-American canal and north of the International
Boundary with Mexico, east of the City of Calexico.

23 **WHEREAS**, Permittee has applied to the County of Imperial for CUP #20-0020 for
24 constructing and operating a new 100 MW solar energy facility, energy (battery) storage
25 facility (up to 200 MW and not to exceed a 1 to 2 solar/battery ratio) with ancillary support
26 facilities, including electrical interconnections. The Project will connect to the existing IID
"P" line located immediately north of the project site north of the All-American Canal.

27 **WHEREAS**, the Project is located on APNs 059-300-015 and 059-300-017-000 that
28 are contiguous to each other. Project is 10 miles east of the City of Calexico in Sections
10, 11, 14, 15 and 16 within Township 17 South and Range 16 East of the SBBM of the
Bonds Corner topographic 7.5 minute quadrangle. The project site is located entirely within
the Imperial County Renewable Energy Overlay zone.

1
2
3
4
5
6
7
8
9
10
11
12
13
14
15
16
17
18
19
20
21
22
23
24
25
26
27
28
29

WHEREAS, The Permittee for the VEGA SES 4 Solar Energy Project (CUP #20-0020) shall fully comply with all the terms and conditions of the Project as specified hereinafter within this CUP.

The rest of this page is intentionally left blank.

1 **GENERAL CONDITIONS:**

2 The "GENERAL CONDITIONS" are shown by the letter "G". These conditions are conditions that are
3 either routinely and commonly included in all Conditional Use Permits as "standardized conditions"
4 and/or are conditions that the Imperial County Planning Commission has established as a requirement
5 on all CUP's for consistent application and enforcement. The Permittee is hereby advised that the
6 General Conditions are as applicable as the SITE SPECIFIC conditions. The General Conditions are in
7 addition to the MMRP and any and all other requirements for the project.

8 **G-1 GENERAL LAWS:**

9 The Permittee shall obtain, comply with, and maintain all applicable County, State,
10 and federal laws, rules, regulations, ordinances, and/or standards as they may
11 pertain to this project whether specified herein or not.

12 **G-2 EFFECTIVE DATE:**

13 The approved Conditional Use Permit shall not become effective until ten (10)
14 calendar days after the decision of the Planning Director or Commission. Further
15 the Conditional Use Permit shall not be effective until applicable conditions have
16 been met, and the Conditional Use Permit is recorded with the County Recorder,
17 with payment of recording fees being paid by applicant. In the case of a decision by
18 the Board of Supervisors there is no 10-day appeal.

19 **G-3 RECORDATION:**

20 CUP #20-0020 shall **not be effective** until it is recorded at the Imperial County
21 Recorder's Office and if no appeal has been made after approval from the hearing
22 body. Payment of the recordation fee shall be the responsibility of the Permittee. If
23 this CUP is not recorded within one hundred eighty (180) days from the date of
24 approval the CUP shall be deemed null and void, without notice having to be
25 provided to Permittee. Permittee may submit a written request for a recordation
26 extension for this CUP by filing such a request with the Planning Director at least
27 sixty (60) days prior to the one hundred eighty 180-day expiration. The Director may
28 approve one (1) extension for a period not to exceed one hundred eighty (180)
29 days. An extension may not be granted if the request for an extension is filed after
30 the expiration date. Failure to record this CUP within one (1) year including the
31 granted extension period shall deem this CUP null and void.

32 **G-4 COMMENCEMENT OF WORK:**

33 If the project for which a CUP has been approved has not commenced, or permits
34 for said project have not been issued, within one (1) year from effective date, the
35 CUP shall be null and void. If an applicant cannot initiate or obtain permits for the
36 approved use during the one (1) year, the applicant may request a one (1) year
37 extension from the Department. The request for an extension shall be in writing and
38 be submitted with explanation to the Planning & Development Services Department
39 at least sixty days prior to the end of the extended one (1) year period. The Director
40 shall have the authority to extend the initial start-up period, or commencement of
41 work, of a CUP up to two (2) times for a maximum of two (2) years. Should the

1 Permittee desire to continue with the project, a new application shall be submitted
2 and the entire process would have to begin anew.

3 **G-5 TIME LIMIT:**

4 Unless otherwise specified within the Site Specific Conditions, this Permit shall be
5 limited to a maximum of thirty (30) years from the recordation of the CUP. The CUP
6 may be extended for an additional ten (10) year period by the appropriate County
7 entity (either the Planning Director, the Planning Commission or the Board of
8 Supervisors as set forth in the applicable Imperial County Ordinances) upon a
9 finding that the Project is in compliance with all conditions of the CUP as stated
10 herein and any applicable Land Use regulation of the County of Imperial. In order to
11 obtain an extension, the Permittee shall file a written extension request with the
12 Planning Director at least sixty (60) days prior to the expiration date of the permit.
Such an extension request shall include the appropriate extension fee. Nothing
stated or implied within this Permit shall constitute a guarantee that an extension
will be granted. An extension may or may not be granted if the Project is in violation
of any one or all of the conditions or if there is a history of non-compliance with the
Permit conditions.

13 **G-6 ABANDONMENT:**

14 If a CUP has been unused, abandoned, discontinued, or ceased for one (1) year,
15 the CUP shall be null and void, and be of no effect. Notice to applicant/permittee
16 under this division will not be required or provided by the Department.

17 **G-7 PERMIT/LICENSE:**

18 Permittee shall obtain and comply with any and all required permits, licenses,
19 and/or approvals, for the construction and/or operation of this project. This shall
20 include, but shall NOT be limited to, permits from the County Division of
21 Environmental Health Services (EHS), Planning & Development Services
22 Department, Office of Emergency Services (OES), Imperial County Air Pollution
23 Control District (ICAPCD) and Public Works Department. Permittee shall likewise
24 comply with all such permit requirements for the life of the project. **Additionally,**
Permittee shall submit a copy of such additional permit(s) and/or license(s) to
the Planning & Development Services Department within 60-days of receipt,
including amendments or alternatives thereto.

25 **G-8 APPROVALS AND CONDITIONS SUBSEQUENT TO GRANTING PERMIT:**

26 Permittee acceptance of this CUP shall be deemed to constitute agreement with the
27 terms and conditions contained herein. Where a requirement is imposed in this CUP
28 that Permittee conduct a monitoring program, and where the County has reserved
the right to impose or modify conditions with which the Permittee must comply
based on data obtained therefrom, or where the Permittee is required to prepare
specific plans for County approval and disagreement arises, the Permittee, operator
and/or agent, the Planning and Development Services Director or other affected
party, to be determined by the Planning and Development Services Director, may

1 request that a hearing be conducted before the Imperial County Planning
2 Commission whereby they may state the requirements which will implement the
3 applicable conditions as intended herein. Upon receipt of a request, the Planning
4 Commission shall conduct a hearing and make a written determination. The
5 Planning Commission may request support and advice from a technical advisory
committee. Failure to take any action shall constitute endorsement of staff's
determination with respect to implementation.

6 **G-9 CONDITION PRIORITY:**

7 This project shall be constructed/operated as described in the CUP application, the
8 environmental documents, the project description, and as specified in these
9 conditions. Where a conflict occurs, the CUP conditions shall govern.

10 **G-10 INDEMNIFICATION:**

11 As part of this application, applicant and real party in interest, if different, agree to
12 defend, indemnify, hold harmless, and release the County of Imperial ("County"), its
13 agents, officers, attorneys, and employees (including consultants) from any claim,
14 action, or proceeding brought against any of them, the purpose of which is to attack,
15 set aside, void, or annul the approval of this application or adoption of the
16 environmental document which accompanies it. This indemnification obligation
17 shall include, but not be limited to, damages, costs, expenses, attorney fees, or
expert witness fees that may be asserted by any person or entity, including the
applicant, arising out of or in connection with the approval of this application,
whether or not there is concurrent negligence on the part of the County, its agents,
officers, attorneys, or employees (including consultants).

18 If any claim, action, or proceeding is brought against the County, its agents, officers,
19 attorneys, or employees (including consultants), to attack, set aside, void, or annul
20 the approval of the application or adoption of the environmental document which
21 accompanies it, then the following procedures shall apply: The Planning Director
22 shall promptly notify the County Board of Supervisors of any claim, action or
23 proceeding brought by an applicant challenging the County's action. The County,
24 its agents, attorneys and employees (including consultants) shall fully cooperate in
25 the defense of that action. The County shall have the final determination on how to
26 best defend the case and will consult with applicant regularly regarding status and
27 the plan for defense. The County will also consult and discuss with applicant the
counsel to be used by County to defend it, either with in-house counsel, or by
retaining outside counsel provided that the County shall have the final decision on
the counsel retained to defend it. Applicant shall be fully responsible for all costs
incurred. Applicant shall be entitled to provide his or her own counsel to defend the
case, and said independent counsel shall work with County Counsel to provide a
joint defense.

28 **G-11 INSURANCE:**

29 The Permittee shall take out and maintain workers compensation insurance as
30 required by the State of California. The Permittee shall also secure liability

1 insurance and such other insurance as required by state and/or federal law. A
2 Certificate of Insurance is to be provided to the Planning and Development Services
3 Department by the insurance carrier and said insurance and certificate shall be kept
4 current for the life of the project. Certificates of Insurance shall be sent directly to
the Planning and Development Services Department by the insurance carrier and
shall name the Department as a recipient of both renewal and cancellation notices.

5 **G-12 RIGHT OF ENTRY:**

6 The County reserves the right to enter the premises at any time, announced or
7 unannounced, in order to make the appropriate inspection(s) and to determine if the
8 condition(s) of this CUP are complied with. Access by authorized enforcement
agency personnel shall not be denied.

9 **G-13 SEVERABILITY:**

10 Should any condition(s) of this CUP be determined by a Court or other agency with
11 proper jurisdiction to be invalid for any reason, such determination shall not
12 invalidate the remaining provision(s) of this CUP.

13 **G-14 PROVISION TO RUN WITH LAND:**

14 The provisions of this CUP are to run with the land/project and shall bind the current
15 and future owner(s) successor(s) of interest; assignee(s) and/or transferee(s) of
16 said CUP. **Permittee shall not without prior notification to the Planning &
17 Development Services Department assign, sell, or transfer, or grant control of
18 CUP or any right or privilege therein.** The Permittee shall provide a minimum of
60 days written notice prior to such proposed transfer becoming effective. The
permitted use identified herein is limited for use upon this parcel described herein
and may not be transferred to another parcel.

19 **G-15 COMPLIANCE/REVOCAION:**

20 Upon the determination by the Planning & Development Services Department that
21 the project is or may not be in full compliance with any one or all of the conditions of
22 this CUP, or upon the finding that the project is creating a nuisance as defined by
23 law, the issue shall be brought immediately to the appropriate enforcement agency
24 or to the Planning Commission for hearing to consider appropriate response
25 including but not limited to the revocation of the CUP or to consider possible
26 amendments to the CUP. The hearing shall be held upon due notice having been
provided to the Permittee and to the public in accordance with established
ordinance/policy.

27 **G-16 NON-COMPLIANCE (ENFORCEMENT & TERMINATION):**

28 Should the Permittee violate any condition herein, the County shall give written
notice of such violation and actions required of Permittee to correct such violation.
If Permittee does not act to correct the identified violation within forty-five (45) days
after written notice, County may revoke the CUP. If Permittee pursues correction of

1 such violation with reasonable diligence, the County may extend the cure period.
2 Upon such revocation, County may, at its sole discretion, cease processing,
3 defending any lawsuit or paying for costs associated with the Project.

4 **G-17 COSTS:**

5 Permittee shall pay any and all amounts determined by the County to defray any
6 and all cost(s) for the review of reports, field investigations, monitoring, and other
7 activities directly related to the enforcement/monitoring for compliance of this CUP,
8 County Ordinance or any other applicable law. Any billing against this project, now
9 or in the future, by the Planning & Development Services Department or any County
10 Department for costs incurred as a result of this CUP, shall be billed through the
11 Planning & Development Services Department.

12 **G-18 REPORT(S)**

13 Permittee shall file an annual report with the Planning and Development Services
14 Department to show that Permittee is in full compliance with this CUP. The report
15 shall be filed at least fifteen (15) days prior to the anniversary (recordation date) of
16 this CUP. It shall be the responsibility of the Permittee to provide all reports and to
17 include the information about other users. The County may request information at
18 any time from the Permittee or other users if applicable; however, it shall be the
19 responsibility of the Permittee to assure that the County receives such information
20 in a timely manner.

21 **G-19 RESPONSIBLE AGENT**

22 Permittee shall maintain on file with the Planning and Development Services
23 Department the name and phone number of the responsible agent for the site. A
24 back-up name shall also be provided, and a phone number for twenty-four (24) hour
25 emergency contact shall also be on file. If there are other users, the same
26 information (as applicable) required from the Permittee shall also be made available
27 to the County from such other users.

28 **G-20 WATER AND SEWER:**

29 Permittee shall provide water and sewer to Federal, State and County standards.
30 Water and sewer systems shall be approved by the Environmental Health Services
31 and the Planning & Development Services Department. Permittee shall hook up to
32 a public water system or supplier if and when available.

33 **G-21 DEFINITIONS:**

34 In the event of a dispute, the meaning(s) or the intent of any word(s) phrase(s)
35 and/or conditions or sections herein shall be determined by the Planning
36 Commission of the County of Imperial. Their determination shall be final unless an
37 appeal is made to the Board of Supervisors ten (10) days from the date of their
38 decision.

1
2 **G-22 SPECIFICITY:**

3 The issuance of this CUP does not authorize the Permittee to construct or operate
4 this project in violation of any state, federal, local law nor beyond the specified
5 boundaries of the project as shown in the application/project description/ CUP, nor
6 shall this CUP allow any accessory or ancillary use not specified herein. This CUP
does not provide any prescriptive right or use to the Permittee for future addition
and/or modification to this project.

7 **G-23 HEALTH HAZARD:**

8 If the County Health Officer determines that a significant health hazard exists to the
9 public, the County Health Officer may require appropriate measures and the
10 Permittee shall implement such measures to mitigate the health hazard. If the
11 hazard to the public is determined to be imminent, such measures may be imposed
12 immediately and may include temporary suspension of the subject operations.
13 However, within forty-five (45) days of any such suspension of operations, the
14 measures imposed by the County Health Officer must be submitted to the Planning
Commission for review and approval. Nothing shall prohibit Permittee from
requesting a special Planning Commission meeting provided Permittee bears all
costs.

15 **G-24 CHANGE OF OWNER/OPERATOR:**

16 In the event the ownership of the site or the operation of the site transfers from the
17 current Permittee to a new successor Permittee, the successor Permittee shall be
18 bound by all terms and conditions of this CUP as if said successor was the original
19 Permittee. The Current Permittee shall inform the County Planning & Development
20 Services Department in writing at least sixty (60) days prior to any such transfer.
21 Failure of a notice of change of ownership or change of operator shall be grounds
for the immediate revocation of the CUP. In the event of a change, the new
Owner/Operator shall file with the Department, via certified mail, a letter stating that
they are fully aware of all conditions and acknowledge that they will adhere to all.

22 **G-25 PERMITS OF OTHER AGENCIES INCORPORATED:**

23 Permits granted by other governmental agencies in connection with the Project are
24 incorporated herein by reference. The County reserves the right to apply conditions
25 of those permits, as the County deems appropriate; provided, however, that
26 enforcement of a permit granted by another governmental agency shall require
concurrency by the respective agency. Permittee shall provide to the County, upon
request, copies and amendments of all such permits.

27 **G-26 MINOR AMENDMENTS:**

28 The Planning Director may approve minor changes or administrative extensions, as
requested in writing by the Permittee, provided it does not result in additional
environmental impacts and/or are generally procedural or technical and/or which
29

1 may be necessary to comply with other government permit compliance
2 requirements.

(TOTAL "G" CONDITIONS are 26)

3
4 **SITE SPECIFIC CONDITIONS:**

5 **S-1 AUTHORIZED SCOPE OF ACTIVITIES:**

- 6
7 (A) Permittee shall be responsible for all improvements, septic, sewer,
8 approved potable water system(s), pipelines, roads and other
9 improvements discussed in the CUP Application and Conditions of
10 Approval, FEIR, and MMRP. If Permittee sells all or part of this Project,
11 an approved agreement shall be in place for new Project owner to build
12 and maintain as agreed to by the conditions set forth in this CUP.
13 Additionally, the County Assessor's Office shall be notified of any
14 ownership change.
- 15 (B) Permittee shall develop this Project per approved CUP as a separate
16 solar energy and energy (battery) storage facility. Any development with
17 a combination of parcels will require the owner(s) to have a recorded
18 deed restriction to "hold the parcel as one parcel" that runs with the
19 land, or at Permittee's option merge the parcels. This deed restriction
20 shall be for a minimum of thirty (30) years and shall only be released
21 upon the expiration of the thirty (30) years, the expiration or termination
22 of the CUP, or upon approval of the Imperial County Planning and
23 Development Director that the restriction is no longer needed based on
24 a change in the development or regulation.
- 25 (C) The Permittee shall construct and operate the solar energy and energy
26 (battery) storage facility in compliance with the CUP, the County's
27 General Plan's Land Use Element, Land Use Ordinance, and all other
28 applicable local, state, and federal LORS, to include any other permits
29 which are incorporated herein by reference.
- 30 (D) Construction, operation, maintenance, replacement, and removal of a
31 solar energy facility & energy (battery) storage system shall be as
32 described in Permittee's CUP Application and previously approved
33 FEIR for the Vega SES 4 Solar Energy project (CUP #20-0020), to
34 include photovoltaic (PV) modules, mounting structures, electrical
35 wiring, inverters, transformers and alternating current (AC) electric
36 collector system, project electric substation and ancillary facilities.
37 Ancillary facilities include safety and security equipment, retention
38 basins, perimeter fencing, access gates, lighting systems, access
39 roads, and may include temporary construction trailers, equipment
40 enclosures, water treatment system and building, septic system,
41 parking, and fire protection. The Project's PV arrays shall be comprised
42 of solar PV panels organized into electrical groups referred to as
43 "blocks." The panels shall be oriented from east to west for maximum

1 sun exposure and the foundation shall be designed based on soil
2 conditions. The PV panels are made of a poly-crystalline silicon
3 semiconductor material encapsulated in glass. Installation of the PV
4 arrays includes installation of mounting posts, module rail assemblies,
5 PV modules, inverters, transformers and buried electrical conductors.
6 Concrete is required for the footings, foundations and pads for the
7 transformers and substation work. Tracker foundations shall be
8 comprised of either driven or vibrated steel posts/pipes, and/or concrete
9 in some places (depending on soil and underground conditions).

- 7 (E) The Project's energy (battery) storage (BESS) component will be
8 located on a concrete pad at the northeastern edge of the project site
9 unless final engineering design and/or IID requirements require a
10 different location.

10 The BESS will consist of banks of batteries and will be supported by a
11 DC Combiner, control panel, and inverter/transformer skid. Each
12 enclosure will include built-in fire suppression systems. The batteries
13 will be lithium-ion based and capable of storing up to 200 MW in total
14 (not to exceed 200 MW. These racks would be integrated into
15 containers or be self-contained in engineered systems such as for
16 example the Tesla Mega Pack. The Project design would meet the
17 minimum spacing required by code and manufacturers specifications.

16 **S-2 AESTHETICS:**

- 17 (A) The Permittee shall design and maintain all buildings and equipment
18 enclosures to have exterior surfaces with neutral, non-reflective colors.
- 19 (B) The Permittee shall design and install lighting at construction storage
20 yards and staging areas, such that light bulbs and reflectors are not
21 visible from public viewing areas; lighting does not create reflected
22 glare; and illumination of the Project facilities, vicinity, and nighttime sky
23 is minimized.
- 24 (C) Lighting shall be designed so exterior light fixtures are hooded, with
25 lights directed downward or toward the area to be illuminated and so
26 that backscatter to the nighttime sky is minimized. The design of the
27 lighting shall be such that the luminescence or light source is shielded
28 to minimize light trespass outside the Project boundary.
- (D) All lighting shall be of the minimum necessary brightness consistent
with worker safety and OSHA requirements.
- (E) High illumination areas not occupied on a continuous basis shall have
switches or motion detectors to light the area only when occupied.

1 **S-3 AGRICULTURE:**

2
3 **MITIGATION FOR THE TEMPORARY CONVERSION OF PRIME FARMLAND,**
4 **FARMLAND OF STATEWIDE IMPORTANCE AND LOCAL IMPORTANCE**

5 Developer shall implement a Mitigation Measure for the loss of Farmland.

6 One of the following options included below shall be implemented prior to the
7 issuance of a grading permit or building permit (whichever is issued first) for the proposed
8 Project:

9 **For Prime Farmland:**

10 Option 1: The Permittee shall procure Agricultural Conservation Easements on a
11 "2 to 1" basis on land of equal size, of equal quality farmland, outside of the path of
12 development. The Conservation Easements shall meet the State Department of
13 Conservation's regulations and shall be recorded prior to issuance of any grading or
14 building permits; or

15 Option 2: The Permittee shall pay an "Agricultural In-Lieu Mitigation Fee" in the
16 amount of 30 percent of the fair market value per acre for the total acres of the proposed
17 site based on five comparable sales of land used for agricultural purposes as of the
18 effective date of the permit, including program costs on a cost recovery/time and material
19 basis. The Agricultural In-Lieu Mitigation Fee, will be placed in a trust account
20 administered by the Imperial County Agricultural Commissioner's office and will be used
21 for such purposes as the acquisition, stewardship, preservation and enhancement of
22 agricultural lands within Imperial County; or

23 Option 3: The Permittee and the County voluntarily enter into an enforceable
24 Public Service Agreement that includes an Agricultural Mitigation payment that is
25 consistent with Board Resolution 2012-05; or

26 Option 4: The Permittee shall revise their CUP Application/Site Plan to avoid
27 Prime Farmland.

28 **For Non-Prime Farmland:**

29 Option 1: The Permittee shall procure Agricultural Conservation Easements on a 1
30 to 1 basis on land of equal size, of equal quality of farmland, outside the path of

1 development. The Conservation Easement shall meet the State Department of
2 Conservation's regulations and shall be recorded prior to issuance of any grading or
3 building permits; or

4 Option 2: The Permittee shall pay an "Agricultural In-Lieu Mitigation Fee" in the
5 amount of 20% of the fair market value per acre for the total acres of proposed site based
6 on five comparable sales of land used for agricultural purposes as of the effective date of
7 the permit, including program costs on a cost recovery/time and material basis. The
8 Agricultural In-Lieu Mitigation Fee, will be placed in a trust account administered by the
9 Imperial County Agricultural Commissioner's office and will be used for such purposes as
10 the acquisition, stewardship, preservation, and enhancement of agricultural lands within
11 Imperial County; or

12 Option 3: The Permittee and the County voluntarily enter into an enforceable
13 Public Service Agreement that includes a Agricultural Mitigation payment that is
14 consistent with Board Resolution 2012-05; or

15 Option 4: The Permittee shall revise their CUP Application/Site Plan to avoid Non-
16 Prime Farmland.

17 **For Local Importance Farmland:**

18 Option 1: The Permittee shall procure Agricultural Conservation Easements on a 1
19 to 1 basis on land of equal size, of equal quality of farmland, outside the path of
20 development. The Conservation Easement shall meet the State Department of
21 Conservation's regulations and shall be recorded prior to issuance of any grading or
22 building permits; or

23 Option 2: The Permittee shall pay an "Agricultural In-Lieu Mitigation Fee" in the
24 amount of 10% of the fair market value per acre for the total acres of proposed site based
25 on five comparable sales of land used for agricultural purposes as of the effective date of
26 the permit, including program costs on a cost recovery/time and material basis. The
27 Agricultural In-Lieu Mitigation Fee, will be placed in a trust account administered by the
28 Imperial County Agricultural Commissioner's office and will be used for such purposes as
the acquisition, stewardship, preservation, and enhancement of agricultural lands within
Imperial County; or

1
2 Option 3: The Permittee and the County voluntarily enter into an enforceable
3 Public Service Agreement that includes a Agricultural Mitigation payment that is
4 consistent with Board Resolution 2012-05; or

5 Option 4: The Permittee shall revise their CUP Application/Site Plan to avoid Local
6 Importance Farmland.

7 (A) Permittee shall minimize paving and ground disturbing activities to the
8 maximum extent practical within agricultural fields to retain soil
9 characteristics.

10 (B) Pest Management Plan. Prior to the issuance of a grading permit or
11 building permit (whichever occurs first), a Pest Management Plan shall be
12 developed by the Permittee and approved by the County of Imperial
13 Agriculture Commissioner. The Permittee shall maintain a Pest Management
14 Plan until reclamation is complete. The Plan shall provide the following:

15 1. Monitoring, preventative, and management strategies for weed and pest
16 control during construction activities at any portion of the project (e.g.,
17 transmission line).

18 2. Control and management of weeds and pests in areas temporarily
19 disturbed during construction where native seed will aid in site revegetation
20 as follows:

- 21 • Monitor for all pests including insects, vertebrates, weeds, and
22 pathogens. Promptly control or eradicate pests when found, or
23 when notified by the Agricultural Commissioner's office that a pest
24 problem is present on the project site. The assistance of a licensed
25 pest control advisor is recommended.
- 26 • All treatments must be performed by a qualified applicator or a licensed
27 pest control operator.
- 28 • "Control" means to reduce the population of common pests below
economically damaging levels, and includes attempts to exclude
pests before infestation, and effective control methods after
infestation. Effective control methods may include
physical/mechanical removal, bio control, cultural control, or
chemical treatments.
- Use of "permanent" soil sterilants to control weeds or other pests is
prohibited because this would interfere with reclamation.
- Notify the Agricultural Commissioner's office immediately regarding any
suspected exotic/invasive pest species as defined by the California
Department of Food Agriculture and the U.S. Department of
Agriculture. Request a sample be taken by the Agricultural
Commissioner's Office of a suspected invasive species. Eradication
of exotic pests shall be done under the direction of the Agricultural
Commissioner's Office and/or California Department of Food and
Agriculture.

1
2 **S-4 AIR QUALITY:**

- 3 (A) The Permittee shall comply at all times with the ICAPCD Regulation
4 VIII, Fugitive Dust Control. Please use MMRP for guidance.
- 5 (B) Prior to commencing construction, the Permittee shall submit a Dust
6 Control Plan to the ICAPCD for approval identifying all sources of PM₁₀
7 emissions and associated mitigation measures during the construction
8 and operational phases of the Project. The Project Proponent shall
9 submit a "Construction Notification Form" to the ICAPCD ten (10) days
10 prior to the commencement of any earthmoving activity. The Dust
11 Control Plan submitted to the ICAPCD shall meet all applicable
12 requirements for control of fugitive dust emissions, including the
13 following measures designed to achieve the no greater than 20%
14 opacity performance standard for dust control:
- 15 (1) All on-site and off-site unpaved roads shall be effectively stabilized,
16 and visible emissions shall be limited to no greater than 20%
17 opacity for dust emissions by paving, chemical stabilizers, dust
18 suppressants, and/or watering.
- 19 (2) All unpaved traffic areas one acre or more in size with seventy-five
20 (75) or more average vehicle trips per day, shall be effectively
21 stabilized, and visible emissions shall be limited to no greater than
22 20% opacity for dust emissions by paving, chemical stabilizers,
23 dust suppressants and/or watering.
- 24 (3) The transport of bulk materials shall be completely covered, unless
25 six inches of freeboard space from the top of the container is
26 maintained with no spillage and loss of bulk material. In addition,
27 the cargo compartment of all haul trucks shall be cleaned and/or
28 washed at the delivery site after removal of bulk material.
- 29 (4) All track-out or carry-out, which includes bulk materials that adhere
30 to the exterior surfaces of motor vehicles and/or equipment
(including tires) that may then fall onto the pavement, shall be
cleaned at the end of each workday, or immediately when mud or
dirt extends a cumulative distance of fifty (50) linear feet or more
onto a paved road within an urban area.
- (5) Movement of bulk material handling or transfer shall be stabilized
prior to handling, or at points of transfer with application of
sufficient water, chemical stabilizers, or by sheltering or enclosing
the operation and transfer line.
- (6) The construction of new unpaved roads is prohibited within any
area with a population of five hundred (500) or more unless the
road meets ICAPCD's definition of a "temporary unpaved road."

1 Any temporary unpaved road shall be effectively stabilized, and
2 visible emissions shall be limited to no greater than 20% opacity
3 for dust emission by paving, chemical stabilizers, dust
suppressants and/or watering.

4 (7) Shall comply with the MMRP's and its applicable mitigations.

5 (C) The Permittee shall implement all applicable standard mitigation
6 measures for construction combustion equipment for the reduction of
7 excess NOx emissions as contained in the Imperial County CEQA Air
Quality Handbook and associated regulations. These measures include:

8 (1) Use of alternative fueled or catalyst equipped diesel construction
9 equipment, including all off-road and portable diesel-powered
10 equipment.

11 (2) Minimize idling time, either by shutting equipment off when not in
12 use or reducing the time of idling to five minutes at a maximum.

13 (3) Limit the hours of operation of heavy-duty equipment and/or the
14 amount of equipment in use.

15 (4) Replace fossil-fueled equipment with electrically driven equivalents
16 (assuming powered by a portable generator set and are available,
cost effective, and capable of performing the task in an effective,
timely manner).

17 (5) Curtail construction during periods of high ambient pollutant
18 concentrations; this may include ceasing construction activity
19 during the peak hour of vehicular traffic on adjacent roadways.

20 (6) Implement activity management (e.g. rescheduling activities to
21 avoid overlap of construction phases, which would reduce short-
term impacts).

22 **S-5 GEOLOGY/SOILS and MINERAL RESOURCES:**

23 (A) Prior to approval of final engineering and grading plans for the Project,
24 the County shall verify that all recommendations contained in the
25 Geotechnical Report for this Solar Facility have been incorporated into
26 all final engineering and grading plans. The County's soil engineer and
engineering geologist shall review grading plans prior to finalization to
27 verify compliance with the recommendations of the report.

28 **S-6 CULTURAL RESOURCES:**

29 (A) Compliance and Monitors shall insure all mitigations set forth in the
30 MMRP are followed.

1 **S-7 HEALTH, SAFETY AND HAZARDOUS MATERIAL/FIRE AND FUELS**
2 **MANAGEMENT:**

- 3 (A) All trash and debris within the Project site shall be disposed of off-site,
4 in accordance with current, local, state, and federal disposal
5 regulations. Compliance with this measure shall be verified by the
6 Planning and Development Services Department.
- 7 (B) If it is determined that hazardous wastes are, or will be generated by the
8 proposed operations, the wastes must be managed in accordance with
9 the California Hazardous Waste Control Law (California Health and
10 Safety Code, Division 20, Chapter 6.5) and the Hazardous Waste
11 Control Regulations (California Code of Regulations, Title 22, Division
12 4.5).
- 13 (C) If it is determined that hazardous wastes will be generated, the
14 Permittee should also obtain a United States Environmental Protection
15 Agency, Identification Number by contacting (800) 618-6942. Certain
16 hazardous waste treatment processes or hazardous material, handling,
17 storage or uses may require authorization from the local Certified
18 Unified Program Agency (CUPA). Information about the requirement for
19 authorization can be obtained by contacting the local CUPA.
- 20 (D) Any hazardous materials storage areas shall be designed with curbs or
21 other containment measures, e.g., double-walled storage tanks, to
22 contain spills and leaks. If on-site hazardous materials exceed fifty-five
23 (55) gallons, a "Hazardous Material Management Plan" shall be
24 prepared and approved by the County Local Enforcement Agency (LEA)
25 and the Imperial County CUPA. A copy of the approved plan shall be
26 submitted to ICPDSD prior to the issuance of the grading/building
27 permit (Source: Imperial County Renewable Energy Ordinance, Title 9,
28 Division 17, § 91702.00).
- 29 (E) The Permittee shall present to the Department an Emergency
30 Response/Action Plan that has been approved by the ICFD/OES
31 Department, and the LEA and any other agencies with jurisdiction
32 (Source: Imperial County Renewable Energy Ordinance, Title 9,
33 Division 17, § 91702.00).

34 The Emergency Response/Action Plan shall cover all possible
35 foreseeable emergencies, e.g., major fluid spills, earthquakes, fires,
36 floods or other emergencies. At all times, there shall be at least one
37 employee either on the facility premises or on-call (i.e., available to
38 respond to an emergency by reaching the facility within a short period of
39 time) with the responsibility to coordinate all emergency response
40 measures. This Emergency Coordinator shall be thoroughly familiar with
41 all aspects of the Project's Emergency Response/Action Plan, all
42 operations and activities at the facility, location of all records within the
43 facility and the facility's layout. This Emergency Coordinator shall have

1 the authority to commit the resources needed to carry out the
2 contingency plan. Adequate personnel and equipment shall be available
3 to respond to emergencies and to ensure compliance with the
conditions of the Permit.

4 The Emergency Response/Action Plan shall be prepared in consultation
5 with, but not be limited to, the ICFD/OES, County EHS/Health
6 Department, County Sheriff/Coroner's office, County Department of
7 Public Works, ICPDSD, and other appropriate state and county
8 agencies. The plan shall include a notification list of response agencies
which shall be notified immediately upon the discovery of a reportable
unauthorized discharge and the list shall include:

- 9 - ICFD/OES;
- 10 - ICPDSD;
- 11 - County EHS/Health Department;
- 12 - County Department of Public Works; and
- 13 - California Highway Patrol, as applicable.

14 All employees shall be appropriately trained on safety procedures,
15 maintenance programs and emergency response protocols to ensure
16 safety and reliability in the event of an unforeseen emergency situation.

17 The Permittee shall provide adequate safety devices to protect against
18 the hazard of fire and explosion for activities that involve the use and
19 storage of flammable, explosive or highly corrosive or reactive materials
20 as well as provide adequate firefighting and fire suppression equipment
21 and using devices standard within the industry in compliance with all
22 applicable state and local laws as determined by the ICFD/OES.
23 The Permittee shall implement all State and County-approved worker
24 safety and fire protection plans and programs.

25 Any gates on-site shall have a "Knox" lock rapidly accessible by the
26 ICFD/OES.

27 Appropriate first aid provisions for facility operations shall be made for
28 emergency response during Project construction, operation, and
29 maintenance activities with appropriate first aid training for Project
30 employees.

31 During construction, a member of each working crew shall be trained in
32 basic first aid and supplied with necessary medical equipment to
33 respond to emergencies as provided for in the Emergency
34 Response/Action Plan required above.

35 Permittee shall identify a responsible agent for emergency purposes,
36 whose name, title, e-mail address and telephone number shall be
37 provided to the County Department of Public Works, ICFD/OES, County

3 **S-8 HYDROLOGY AND WATER QUALITY:**

4 Adhere to measures set forth in the MMRP.

5 **S-9 BIOLOGICAL RESOURCES:**

6 Adhere to all Biological measures in the MMRP.

7 **S-10 PUBLIC SERVICES:**

8
9 (A) The Permittee shall widely publicize to County residents the availability of job
10 opportunities associated with the Project (whether or not those job opportunities are
11 within Imperial County or are regional). Postings at City Halls, newspaper and
12 television advertisements, local job centers, and dedicated website shall offer
13 sufficient avenues of communication. The Imperial County Office of Employment
14 and Training in addition to the Imperial Valley College presents viable sources for
15 community awareness. The information shall provide available positions, details of
16 positions including qualifications, number of openings, indicated the anticipated start
17 date for each, and application process. In order to maintain oversight of the
18 process, the application process can be completed both on a dedicated website and
19 at dedicated computers at the County which would afford those without Internet
20 connection the ability to apply. The Permittee's information shall be forwarded to the
21 Permittee or their contractor and copies of applications files are maintained at the
22 County.

23 (B) Unless prohibited by local, state or federal law or regulation, Permittee shall make
24 good faith efforts to hire qualified residents of the Imperial County with the objective
25 that a majority of the total work force is comprised of the Imperial County residents.

26 (C) The Permittee shall install and implement security measures which may include,
27 but not limited to, secured perimeter fencing with barbed wire, sensors, controlled
28 access points, security alarms, security camera systems, and security guard vehicle
29 patrols to deter trespass or unauthorized activities that would interfere with
30 operation of the Project.

(D) The Permittee shall reimburse the Sheriff's Department for any investigations
regarding theft on the Project site and related law enforcement.

(E) All construction supervisors and foremen shall be provided with communication
devices, cell phones or walkie-talkies, in the event of an emergency situation on-
site.

(F) All construction-related activities shall take place within the development footprint of
the Project as defined by the final engineering plans. The anticipated impact areas,
including staging areas, equipment access, and disposal or temporary placement of

1 spoils, shall be delineated with staking and/or orange construction fencing prior to
2 construction to avoid natural resources where possible. No construction-related
3 activities shall occur outside of the designated impact area. All construction
4 materials, staging, storage, dispensing, fueling, and maintenance activities shall be
5 designated on construction maps and shall be situated a minimum of fifty (50) feet
6 from all drainages. Staging and temporary access shall occur on existing roadways
7 whenever possible.

8 (G)**Emergency Operations Plan** - The Applicant shall develop an Emergency
9 Operation Plan in conjunction with local fire service personnel and the AHJ and hold
10 a comprehensive understanding of the hazards associated with lithium-ion battery
11 technology. Lithium-ion battery energy storage systems must incorporate adequate
12 explosion prevention protection as required in NFPA 855 or International Fire Code
13 Chapter 12, where applicable.

14 (H)**Signage** - The Applicant shall provide signage that identifies the contents of an
15 energy storage system on all energy storage system installations to alert first
16 responders to the potential hazards associated with the installation.

17 **S-11 TRANSPORTATION AND TRAFFIC:**

18 A. Permittee shall prepare and submit a Construction Traffic Control Plan
19 to Imperial County Department of Public Works-Development Review
20 and Caltrans District 11, as appropriate, for approval. The
21 Construction Traffic Control Plan must be prepared in accordance
22 with both the California Department of Transportation Manual on
23 Uniform Traffic Control Devices and Work Area Traffic Control
24 Handbook and must include, but not be limited to, the following
25 issues:

- 26 1. Timing of deliveries of heavy equipment and building
27 materials;
- 28 2. Directing construction traffic with a flag person;
- 29 3. Placing temporary signing, lighting, and traffic control
30 devices if required, including, but not limited to, appropriate
signage along access routes to indicate the presence of
heavy vehicles and construction traffic;
- 31 4. Ensuring access for emergency vehicles to the Project site;
- 32 5. Temporarily closing travel lanes or delaying traffic during
materials delivery, transmission line stringing activities, or
any other utility connections;
- 33 6. Maintaining access to adjacent property;
- 34 7. Specifying both construction-related vehicle travel and
oversize load haul routes, minimizing construction traffic
during the AM and PM peak hours, distributing construction
traffic flow across alternative routes to access the Project
site, and avoiding residential neighborhoods to the maximum
extent feasible.

- 1
- 2 B. Permittee shall Institute construction work hours as necessary, such
- 3 that the arrival and/or departure times of workers would be staggered
- 4 as necessary.
- 5
- 6 C. Permittee shall identify vehicle safety procedure for entering and
- 7 exiting site access roads.
- 8
- 9 D. Permittee shall submit documentation that identifies the roads to be
- 10 used during construction.
- 11
- 12 E. The Permittee shall be responsible for repairing any damage to non-
- 13 County maintained roads that may result from construction activities.
- 14 The Permittee shall submit a preconstruction video log and inspection
- 15 report regarding roadway conditions for roads used during
- 16 construction to the Imperial County Department of Public Works
- 17 Within 30 days of completion of construction, the project
- 18 proponent/operator shall submit a post-construction video log and
- 19 inspection report to the County. This information shall be submitted in
- 20 electronic format. The County, in consultation with the Permittee's
- 21 engineer, shall determine the extent of remediation required, if any.
- 22
- 23
- 24

25 **S-12 COMMENCEMENT OF WORK:**

- 26 (A) If the Project has not commenced, or permits for the Project have not
- 27 been issued, within one (1) year from approval date this CUP shall be
- 28 null and void. If this CUP has been unused, abandoned, discontinued, or
- 29 ceased for one (1) year, it shall be null and void and of no effect.
- 30 (B) If Permittee cannot initiate or obtain permits for the approved use during
- the one (1) year period following approve of this CUP, Permittee may
- request a one (1) year extension from the ICPDSD. The request for an
- extension shall be in writing and be submitted with explanation to the
- ICPDSD at least sixty (60) days prior to the end of the one (1) year
- period. The Director shall have the authority to extend the initial startup
- period of a CUP two times for a maximum of one (1) year each. No
- extension under this section shall be extended for more than two (2)
- years.

31 **S-13 CONSTRUCTION STANDARDS:**

- 32 (A) The solar energy and energy (battery) storage facility structures shall
- 33 be built in accordance with the California Building Code requirements
- 34 applicable to "Seismic Category D". All structures and facilities shall be
- 35 designed in accordance with the publication entitled "Recommended
- 36 Lateral Force Requirements and Commentary by the Structural
- 37 Engineers Association of California". The structural components of the
- 38 permitted facilities shall be reviewed by the Building Official/Planning
- 39 and Development Services Director. Applicable building permits shall be
- 40

1 procured from the County for facilities prior to commencement of
2 construction of such facilities.

3 **S-14 LAND USE IMPROVEMENTS:**

- 4 (A) The Permittee shall prepare an appropriate parking plan for review
5 and approval by the ICPDSD and County Public Works Department for
6 any and/or all proposed Operation & Maintenance buildings.
7 (B) The Permittee shall surface with a material of higher quality all access
8 drives, parking areas, and vehicular maneuvering areas from primary
9 access to any constructed operation and maintenance buildings.

9 **S-15 NOISE STANDARDS:**

- 10 (A) During the construction period, heavy truck traffic shall be limited to
11 the hours between 6:00 AM and 7:00 PM.
12 (B) During construction, in accordance with Imperial County Noise
13 Element of the General Plan, the noise level shall not exceed 75
14 dBA_{Leq} at the property boundary when averaged over an 8-hour
15 period.
16 (C) During operation of the facility, the maximum permitted continuous
17 sound level shall be not more than 45 dBA_{Leq}, as measured at the
18 nearest residence using the "A" scale and measured with a sound
19 level meter and associated octave band analyzer. The level may be
20 exceeded by ten percent (10%) if the noise is intermittent and during
21 daylight hours.
22 (D) Haul trucks and other engine-powered equipment shall be muffled and
23 operated with engine exhaust brake use limited to emergencies.

22 **S-16 ODOR CONTROL:**

23 The Permittee shall control all odor-causing, harmful, noxious emissions to
24 ensure that quantities or air contaminants released as a result of the
25 permitted facilities do not exceed County, State or Federal standards, nor
26 constitute a public nuisance, per the Imperial County Land Use Ordinance,
27 Division 13, Enforcement, Chapter 2, Abatement of Nuisances, Sections
28 91302.00 through 91301.02.

27 **S-17 PLAN APPROVALS:**

28 Permittee shall submit to the ICPDSD, architectural, landscaping and lighting
29 plans prior to construction of those facilities, to include painting of structures,
30 planting of trees and/or vegetation, and shall receive all approvals prior to
31 commencing construction of the applicable permitted facilities. Approval

1 shall not be unreasonably withheld so long as the plans are consistent with
2 applicable Imperial County Land Use Ordinance requirements.

3 **S-18 PROJECT DESIGN:**

- 4 (A) All facility access and parking areas shall be constructed to the
5 standards of the Imperial County Land Use Ordinance.
- 6 (B) All permitted activities shall provide for the minimum feasible surface
7 land disturbance for compatibility with the existing uses wherever
8 possible.
- 9 (C) All equipment and electrical interconnection facilities used at the solar
10 plant facilities shall be maintained in a manner that prevents breaking,
11 cracking, and leaking, e.g., operator staffing and training, including
12 appropriate quality assurance procedures, with the operation of back-up
13 or auxiliary facilities when necessary.
- 14 (D) All on-site basins shall be designed and constructed under the
15 supervision of a California-licensed Civil Engineer meeting sound
16 engineering standards, with all applicable regulations and all
17 requirements of the County EHS/Health Department and Public Works
18 Departments are complied with.
- 19 (E) Permittee shall obtain encroachment permits for any construction or
20 operation on IID existing rights of way or easements.

21 **S-19 REPORTING AND MONITORING:**

- 22 (A) The Permittee shall furnish to the County, at its sole cost within a
23 reasonable time, any relevant reports/information which the County
24 requires for monitoring purposes to determine whether cause exists for
25 revoking this Permit, or to determine compliance with this Permit. The
26 Permittee shall submit all required reports to the Planning Director,
27 County Planning and Development Services Department, 801 Main
28 Street, El Centro, CA 92243.
- 29 (B) Permittee and ICPDSD Director shall agree upon an environmental
30 consultant for overseeing all the required mitigation, conditional use
31 Permit conditions and public benefit agreement (if any) requirements
32 during the construction of the Project.
- 33 (C) Permittee shall pay for third-party environmental consultant monitoring
34 and compliance.
- 35 (D) The ICPDSD, in consultation with the third-party Environmental
36 Consultant and the County Executive Office, will require that all
37 mitigation measures be satisfied, all MMRP requirements have been
38 satisfied, all Conditions of Approval in the CUP are in full compliance

1 and all conditions of the Development Agreement (if any) have been
2 satisfied before the Final Certificate of Occupancy Certificate is issued.

- 3 (E) During the operation of solar facility, an Annual Compliance Report shall
4 be submitted to the ICPDS, documenting the implementation of the
5 conditions and general measures as well as any resource-specific
6 measures.
- 7 (F) The Permittee shall reimburse the ICPDS for County as well as
8 monitoring and investigations related to the construction and operation
9 of the Project. Permittee shall compensate the County pursuant to the
10 ICPDSD Fee Schedule for any costs incurred.
- 11 (G) Permittee shall pay for all costs as required to comply with the
12 Conditions of Approval and MMRP.
- 13 (H) All County staff time will be billed on a time and materials basis. Failure
14 by Permittee to provide any payment required of Permittee to the
15 County in the CUP shall cause Permittee to be in non-compliance of the
16 CUP. Upon notice of such noncompliance, County may, at its sole
17 discretion, cease processing, defending any lawsuit or paying for costs
18 associated with the Project.

19 **S-20 SPILLS AND RUNOFF:**

20 The Permittee shall design and construct the permitted facilities to prevent
21 spills from endangering adjacent properties and to prevent runoff from any
22 source being channeled or directed in an unnatural way so as to cause
23 erosion, siltation, or other detriments pursuant to the construction Storm
24 Water Pollution Prevention Plan approved by the Regional Water Quality
25 Control Board.

26 **S-21 FACILITIES CLOSURE AND SITE RESTORATION:**

- 27 (A) Permittee shall implement the site restoration plan at the earlier of when
28 the operation of the permitted facilities herein authorized has ceased or
29 the term of the CUP has expired. At such time, all facilities shall be
30 dismantled, and the lands involved restored to their pre-construction
condition and available for agricultural production uses as agreed to by
the Imperial County Planning and Development Services Director.
- (B) Prior to the issuance of a grading Permit, a decommissioning and
restoration plan (the Reclamation Plan) shall be submitted and
approved by the Imperial County Planning and Development Services
Director. The Reclamation Plan shall documents the procedures by
which the Project site will be returned to its current conditions.
- (C) Within thirty (30) days prior to ground disturbance, a Bond, or other
acceptable surety, in the amount of the estimated site restoration

1 financial calculations/bond, for the developed project area, or other
2 forms of security acceptable to County Counsel's office, shall be filed
3 with the County that guarantees restoration of the land to its condition
4 prior to the permitted solar plant development.

5 (D) Upon completion of such site restoration, and demonstration that the
6 land has been restored to the agriculturally productive/farmable
7 condition prior to the permitted solar plant development the Bond or
8 other surety shall be released by the County.

9 (E) The above financial calculations/bond shall be reviewed every five (5)
10 years in December and adjusted on January 1st to add a Consumer
11 Price Index (CPI) (Los Angeles) increase by the Planning and
12 Development Services Director. This readjustment can be made in the
13 County's sole discretion and must be funded by the Permittee within
14 ninety (90) calendars after notice of the additional amount of such
15 adjustment.

16 **S-22 PUBLIC WORKS:**

- 17 1. The Applicant shall acquire proper easements from adjacent property owners for the
18 installation of any proposed transmission lines.
- 19 2. All survey monuments, including those within the interior of the project, shall be
20 protected, and their locations shall remain accessible to any surveyor throughout the
21 duration of the project. Section 8774 of the Business and Professions Code, and
22 Section 846.5 of the Civil Code, each provide the right of entry to utilize boundary
23 evidence and perform surveys, without undue delay, to any person authorized to
24 practice land surveying. The right of entry is not contingent upon prior notice.
- 25 3. The Applicant shall furnish a Drainage and Grading Plan/Study to provide for property
26 grading and drainage control, which shall also include prevention of sedimentation of
27 damage to off-site properties. The Study/Plan shall be submitted to the Department of
28 Public Works for review and approval. The applicant shall implement the approved
29 plan. Employment of the appropriate Best Management Practices (BMP's) shall be
30 included (Per Imperial County Code of Ordinances, Chapter 12.10.020 B).
- 31 4. Based from the information provided on the project documents, it is assumed that
32 County roads will not be used for site access during or after construction activities
33 have been completed. In the event that County roads are required for site access,
34 the Applicant shall consult with this Department in advance for review and approval.

35 Access to sites shall be completed from public roads.

- 36 5. Any unimproved access roads/routes between public roads and access gates shall
37 be improved for all-weather access. Such all-weather improvements shall be
38 completed as recommended by a Geotechnical Engineer licensed to practice in the
39 State of California.

1 6. Each site shall have, as a minimum, one (1) primary Class 2 Base aggregate material
2 driveway and one (1) emergency access Class 2 Base aggregate material driveway, if
3 they are tied to a County Road only.

4 7. Access to project sites during and after construction is expected to be completed
5 through private unpaved roads or private property.

6 **The Applicant shall mitigate generation of dust caused by construction traffic**
7 **as per Rule 805 – Paved and Unpaved Roads of the Imperial County Air**
8 **Pollution Control District.**

- 9 • All solid and hazardous waste shall be disposed of in approved solid waste disposal
10 sites in accordance with existing County, State and Federal regulations (Per
11 Imperial County Code of Ordinances, Chapter 8.72).
- 12 • All on-site traffic areas shall be hard surfaced to provide all weather access for
13 emergency vehicles. The surfacing shall meet the Department of Public Works and
14 Fire/Office of Emergency Services (EOS) Standards as well as those of the Air
15 Pollution Control District (APCD).
- 16 • The project may require a National Pollutant Discharge Elimination System
17 (NPDES) permit and Notice of Intent (NOI) from the Regional Water Quality Control
18 Board (RWQCB) prior to County approval of onsite grading plan (40 CFR 122.28).
- 19 • A Transportation Permit may be required from road agency(s) having jurisdiction
20 over the haul route(s) for any hauls of heavy equipment and/or large vehicles which
21 impose greater than legal loads on riding surfaces, including bridges. (Per Imperial
22 County Code of Ordinances, Chapter 10.12 - OVERWEIGHT VEHICLES AND
23 LOADS).
- 24 • Effective September 15, 2020, the State's Mandatory Organic Waste Recycling
25 Law (AB 1826 or Chapter 727, Statutes of 2014) decreased the threshold requiring
26 all businesses and multi-dwelling facilitates of 5 units or more generating two (2)
27 cubic yards or more of solid waste per week to recycle their organic waste
28 including landscape waste, wood waste, and food waste. Information about
29 possible organics waste recycling services can be found at the CalRecycle site at:
30 <https://www.calrecycle.ca.gov/Recycle/Commercial/Organics/>

31 **S-23 WASTE DISPOSAL**

- 1 (A) The Permittee shall insure that all solar plant facilities waste, liquid, gas
2 or solid, which are generated on-site shall be disposed of in compliance
3 with appropriate local, state, and federal regulations, in effect or as
4 subsequently duly-enacted. All solid waste debris and/or any
5 hazardous wastes located on the Project site must be satisfactorily
6 removed to a permitted facility prior to the commencement of grading
7 earthen material at the site.
8
- 6 (B) Littering shall not be allowed. Project personnel shall not deposit or
7 leave any food or waste in the Project area, and no biodegradable or
8 non-biodegradable debris shall remain in the right-of-way or on the
9 Project site following completion of construction.

9 **S-24 CALTRANS:**

- 10 (A) An encroachment permit shall be required for any work performed
11 within any Caltrans right-of-way. If required, any traffic control will need
12 to be addressed as part of Caltrans permit approval in accordance with
13 the Caltrans Standard Plans and the California Manual on Uniform
14 Traffic Control Devices (MUTCD).
- 14 (B) Any application for a permit for work performed within a Caltrans right-
15 of-way must include an approved final environmental document
16 including the California Environmental Quality Act (CEQA)
17 determination addressing any environmental impacts within the Caltrans
18 right-of-way and any corresponding technical studies, if required. If
19 these materials are not included with the encroachment permit
20 application, the Permittee will be required to acquire and provide these
21 to Caltrans before the permit application will be accepted. Identification
22 of avoidance and/or mitigation measures will be a condition of
23 encroachment permit approval as well as procurement of any necessary
24 regulatory and resource agency permits.
- 21 (C) Any work performed within Caltrans' Right of Way (R/W) will require
22 discretionary review and approval by Caltrans. As part of the
23 encroachment permit process, the applicant must provide an approved
24 final environmental document, corresponding technical studies, and
25 necessary regulatory and resource agency permits, specifically, any
26 CEQA determinations or exemptions.

25 **S-25 IID Condition requirements**

- 26 (A) The Project may impact IID drains with project site runoff flows draining
27 into IID drains. To mitigate impacts, IID may require a comprehensive
28 IID hydraulic drainage system analysis. IID's hydraulic drainage system
29 analysis includes an associated drain impact fee.
- 29 (B) An IID encroachment permit is necessary to utilize existing surface-
30 water drainpipe connections to drains and receive drainage service from

1 IID. Surface-water drainpipe connections are to be modified in
2 accordance with IID standards. A construction storm-water permit from
3 the California Regional Water Quality Control Board is required before
4 commencing construction and an industrial storm water permit from
5 CRWQCB is needed for the operation of the proposed facility. Copies of
these permits as well as the project's Storm Water Pollution Prevention
Plan are to be submitted to IID.

6 **S-26 FIRE PROTECTION:**

7 Energy storage facilities create extreme hazards for firefighters and emergency
8 responders with possibility of explosions, flammable gases, toxic fumes, water-
9 reactive materials, electrical shock, corrosives, chemical burns. The hazards
10 listed can create a potential significant impact on Imperial County Fire
11 Department due personnel staffing to safely perform firefighting operations and
12 Hazardous Material Response for a utility-scale energy storage facility. The
13 location of the project will lead to longer response times. These longer response
14 times can create incidents that can create difficulties in incident stabilization;
therefor requiring additional personnel to safety manage the incident. Utility-
scale energy storage will require specialized and reliable equipment to perform
firefighting operations safely and effectively to NFPA, OSHA and ICFD standards
and requirements.

Standards and requirements for energy storage system includes but not limited
to:

16 **NFPA:**

- 17 1 Fire Code
- 18 70 National Electrical Code
- 19 855 Standard for the installation of Energy Storage System
- 20 111 Stored Electrical Energy Emergency and Standby Power System
- 21 1710 Standard for Organization and Deployment of Fire Suppression
Operations, Emergency Medial Operations, and Special Operations to the
Public by Career Fire Departments.

22 **OSHA:**

- 23 29 CFR 1910.134(g)(4)

24 **CFC:**

- 25 Chapter 12 section 1206 Electrical Energy Storage System
- 26 Chapter 9 Fire Protection and Life Safety System.

- 27 1) Vega Solar Energy and Storage Project reviews for plans and inspections
will be done by a third-party consultant determined by the Fire Department
28 at the applicant's expense as per California Fire Code Chapter 1 [A]
104.7.2 Technical Assistance. This will be at the discretion of the Fire
Department.

- 1 2) Project will provide adequate Fire water. Fire Department will determine
2 number of gallons to be placed strategically once site plan is reviewed.
- 3 3) Signage that identifies the contents of an ESS is required on all ESS
4 installations to alert first responders to the potential hazards associated
5 with the installation.
- 6 4) Fire- In lieu of providing all-weather access roads for fire protection
7 vehicles, the permittee shall be permitted to provide compacted native soil
8 (in compliance with ICAPCD's rules and regulations) for fire protection
9 vehicles if prior to the issuance of any grading permit. .
- 10 5) An approved water supply capable of supplying the required fire flow
11 determined by appendix B in the California Fire Code shall be installed
12 and maintained. Private fire service mains and appurtenance shall be
13 installed in accordance with NFPA 24.
- 14 6) An approved automatic fire suppression system shall be installed on all
15 structures as per the California Fire Code. All fire suppression systems
16 will be installed and maintained to the current adapted fire code and
17 regulations.
- 18 7) An approved automatic fire detection system shall be installed on all
19 structures as per the California Fire Code. All fire detection systems will
20 be installed and maintained to the current adapted fire code and
21 regulations.
- 22 8) Fire department access roads and gates will be in accordance with the
23 current adapted fire code and the facility will maintain a Knox Box for
24 access on site.
- 25 9) Compliance with all required sections of the fire code.
- 26 10) Applicant shall provide product containment areas(s) for both product and
27 water run-off in case of fire applications and retained for removal.
- 28 11) All hazardous material and wastes shall be handled, store, and disposed
as per the approved Hazardous Waste Materials Plan. All spills shall be
documented and reported to Imperial County Fire Department and CUPA
as required by the Hazardous Waste Material Plan.

S-27 COUNTY EXECUTIVE OFFICE:

1. Fiscal and Economic Impact Analysis. The Permittee will be invoiced by the Executive Office for expenses related to the procurement of a consultant to produce a Fiscal and Economic Impact Analysis (FEIA) and will be responsible for the cost of any subsequent updates as a result of modifications to the data and project by the developer.

1 2. Public Service Agreement (“Agreement” or “PSA”). Pursuant to the Guidelines
2 for the Public Service Program for Solar Power Plants in Imperial County
3 amended and adopted by the Board of Supervisors on May 9, 2023, PSA will
4 be entered into by and between the County of Imperial and Developer to
provide for a concerted and coordinated effort to maximize the benefits of the
Project to the County of Imperial community.

5 **Sales Tax Benefit Solar Farm:**

- 6
- 7 (a) Developer will require that all qualifying contractors and subcontractors exercise
8 their option to obtain a California Department of Tax and Fee Administration
9 (CDTFA) sub-permit for the jobsite and allocate all eligible use tax payments to
10 Imperial County and LTA. Prior to commencement of any construction activity
11 on-site the developer will require that the contractor or subcontractor provide
12 County of Imperial with either a copy of their CDTFA account number and sub-
13 permit.
 - 14 (b) To accomplish this, Permittee shall either cause its construction contractor to
15 treat the project in accordance with California Regulation 1521(b)(2)(B),
16 California Regulation 1521(c)(13)(B), and California Regulation 1826(b) for
17 sales and use tax purposes or form a “Buying Company” as defined in the
18 CDTFA 1699(h). Permittee can adopt an alternate methodology to accomplish
19 this goal if such methodology is approved by the County Executive Officer prior
20 to issuance of building permits. Not later than forty five (45) days after the due
21 date for filing sales and use tax returns for each calendar quarter, occurring
22 after the commencement of any construction activity on-site through and
23 including the first anniversary of COD (as defined below),
 - 24 (c) Developer shall report, or cause its general contractor to report to County, the
25 total amount of sales and use taxes related to the Project that are allocated to
26 the County, and reported on Developer’s, general contractor’s, and
27 subcontractors’ applicable California sales and use tax returns. The obligations
28 of Developer under this Section III.A are hereinafter referred to as the
“Developer Sales and Use Tax Responsibilities.”
 - (d) Guarantee Amounts. In the event that Developer shall fail to perform the
Developer Sales and Use Tax Responsibilities and as a result of such failure,
with respect to the Project, (i) County receives less than the amount of such
sales and use taxes it would have received under existing applicable sales and
use tax laws had such responsibilities been fully performed subject to
adjustment as set forth in Section IV.C below) or (ii) Local Transportation
Authority (LTA) receives less than the amount of such sales and use taxes it
would have received under existing applicable sales and use tax laws had such
responsibilities been fully-performed, then Developer shall pay, as and when
provided below, to County or LTA as applicable, the amount of the applicable
shortfall.
 - (e) Adjustments to Guarantee Amounts.
 - (f) Developer’s sales tax guarantee set out in Section III.B above shall be adjusted
to be eighty-five percent (85%) of the projected sales and use taxes for the
Project. At least ten (10) days prior to the issuance of the first (1st) grading
permit, Developer shall provide County with evidence of such projected sales
and use taxes, including but not limited to sales taxes receipts, engineering

1 contracts, procurement contracts, construction contracts. County shall meet
2 with Developer to confirm that amount.

- 3 (g) The amount of sales and use tax are to be generated based on the actual cost
4 of construction of the one hundred megawatt alternating current 100 MW AC
5 solar generation facility.
- 6 (h) The complete amount due to County for the Project must be received within one
7 (1) year after Commercial Operation Date (“COD”) for this Project. If, within one
8 (1) year after issuance of the final Certificate of Occupancy, the sales and use
9 taxes received by the County are less than the amount guaranteed for that
10 portion of the project, Developer shall pay the difference to the County.
- 11 (i) Payments to County and LTA as a result of a shortfall shall be due within thirty
12 days of Developer’s receipt of written notice of shortfall from the County.
13 Payments received by County after the ninetieth (90th) day following
14 Developer’s receipt of notice shall be deemed late. Developer hereby agrees to
15 pay interest at the rate of six percent (6%) per annum of the payment due for
16 any payment received by County beyond the due date. Said interest shall be
17 included with the late payment. The obligation to pay interest shall be stayed
18 when such amounts are disputed in good faith, so long as Developer submits
19 the payments “under written protest.” Upon determination of dispute, such
20 interest may be assessed if it is determined that the dispute was not made in
21 good faith.
- 22 (j) In the event that Developer repowers or replaces the equipment onsite, each
23 Site shall be designated as the “Point of Sale” so as to create an additional local
24 tax-funding source for the County of Imperial.

25 **I. Battery Storage Sales Tax Benefit**

- 26 **1.1.1.** To the extent permitted by applicable local, state, and Federal law, Developer
27 will require that all qualifying contractors and subcontractors exercise their
28 option to obtain a California Department of Tax and Fee Administration
29 (“CDTFA”) sub-permit for the jobsite and allocate all eligible sales and use tax
30 payments to County and the Local Transit Authority (“LTA”).
- 31 **1.1.2.** Prior to commencement of any construction activity onsite exclusive of grading,
32 , Developer shall require that the contractor or subcontractor provide County
33 with a copy of their CDTFA account number and sub-permit. Developer shall
34 either cause its construction contractor to treat the Project in accordance with
35 California Sales and Use Tax Regulation 1521(b)(2)(B), California Sales and
36 Use Tax Regulation 1521(c)(13)(B), and California Sales and Use Tax
37 Regulation 1826(b) for sales and use tax purposes, or form a “Buying
38 Company,” as defined in the California Sales and Use Tax Regulation 1699(h).
39 Developer may adopt an alternate methodology to accomplish this goal if such
40 methodology is approved by the County’s Executive Officer prior to issuance of
any building permit.
- 41 **1.1.3.** No later than forty-five (45) days after the due date for filing sales and use tax
returns for each calendar quarter, occurring after the commencement of any
construction activity on-site through and including the first anniversary of

1 commercial operating date ("COD"), Developer shall report, or cause its general
2 contractor to report to County, the total amount of sales and use taxes related
3 to the Project that are allocated to the County, and reported on Developer's,
4 general contractor's and subcontractors' applicable California sales and use tax
5 returns.

6 **1.1.4. *Guarantee Amounts.*** Prior to the issuance of any building permit for the
7 Project, Developer shall provide County with a guarantee of the minimum sales
8 and use tax that will be received by County and LTA under existing applicable
9 sales and use tax laws. The guaranteed amount shall be based on those
10 material and items subject to sales and use tax laws purchased for the
11 construction of the Project. Should Developer choose to develop the Project in
12 phases, and receives the required approvals from County to do so, then
13 Developer shall provide a separate guarantee amount for each phase of the
14 Project.

15 **a.** Developer warrants that the sales/use tax guarantee amounts to be provided to
16 County as mandated in this Subparagraph 9.2.4 shall be true and accurate
17 estimates of the projected sales and use taxes that will be generated for this
18 Project.

19 **b.** Developer shall provide County with evidence of the projected sales/use taxes
20 for the Project, including but not limited to sales tax receipts, and executed or
21 anticipated engineering contracts, procurement contracts, and construction
22 contracts. If the Parties are unable to agree upon a guarantee amount, then the
23 dispute shall be referred to an independent accountant mutually acceptable to
24 both Parties. The costs for such nonbinding mediation shall be borne by
25 Developer.

26 **c.** Developer warrants that the sales/use tax guarantee amounts to be provided to
27 County as mandated in this Subparagraph 9.2.4 will incorporate any and all
28 sales/use tax exemptions that Developer and/or its contractors and
29 subcontractors intend to utilize, and that such exemptions will be disclosed to
30 County fully and in good faith prior to the issuance of any building permit for this
31 Project.

32 **d.** Developer understands and acknowledges that the sales/use tax guarantee
33 amounts to be provided to County as mandated by this Subparagraph 9.2.4 are
34 a part of the consideration to be received by County in return for entering into
35 this Agreement, and further understands and acknowledges that County would
36 not enter into this Agreement but for said guarantee from Developer.

37 **1.1.5.** In the event that County and / or LTA receives less than the amount of
38 sales/use taxes guaranteed pursuant to Subparagraph 9.2.4, then Developer
39 shall pay, as and when provided below, to County or LTA as applicable, the
40 amount of the applicable shortfall.

41 **1.1.6. *Adjustments to Guarantee Amounts.***

42 **a.** The amount of sales and use tax anticipated to be generated is based on those
43 material and items subject to sales and use tax laws purchased for the
44 construction of the Project.

45 **b.** To the extent of any reduction in the size of the Project as the result of any final
46 ruling, stipulated judgment, or settlement, the sales/use tax guarantee amounts

1 mandated under Subparagraph 9.2.4 shall be reduced pro rata based on the
2 size of such reduction.

3 **c.** Should Developer become aware of a change in circumstances that would
4 materially affect the sales/use tax guarantee amount, then Developer shall,
5 within thirty (30) days of learning of such change in circumstances, inform the
6 County in writing of the change in circumstances. If the County determines that
7 such change in circumstances warrants an adjustment to the sales/use tax
8 guarantee amount, then County shall negotiate in good faith with Developer in
9 revising the sales/use tax guarantee amount. If the Parties are unable to agree
10 upon a revised guarantee amount, then the dispute shall be referred to an
11 independent accountant mutually acceptable to both Parties. The costs for
12 such nonbinding mediation shall be borne by Developer. Failure of the
13 Developer to inform the County of the change in circumstances shall constitute
14 a waiver of Developer's ability to seek any adjustment to the sales/use tax
15 guarantee based on such change in circumstances.

16 **1.1.7.** The complete sales/use tax guarantee amount due to County and LTA for the
17 Project must be received within one (1) year after COD for this Project, or such
18 later date as any applicable sales/use tax is due or is transmitted from the
19 CDTFA, unless it is delayed due to causes beyond Developer's control or for
20 which Developer is not responsible. If, within one (1) year after issuance of the
21 final certificate of occupancy, or such later date as any applicable sales/use tax
22 is due or is transmitted from the CDTFA, the sales/use taxes received by the
23 County are less than the sales use tax guarantee amounts mandated under
24 Subparagraph 9.2.4, then Developer shall pay the difference to the County.

25 **1.1.8.** Payments to County and LTA as a result of a shortfall shall be due within thirty
26 days of Developer's receipt of written notice of shortfall from the County.
27 Payments received by County after the ninetieth (90th) day following
28 Developer's receipt of notice shall be deemed late. Developer hereby agrees to
29 pay interest at the rate of six percent (6%) per annum of the payment due for
30 any payment received by County beyond the due date. Said interest shall be
included with the late payment. The obligation to pay interest shall be stayed
when such amounts are disputed in good faith, so long as Developer submits
the payments "under written protest." Upon determination of dispute, such
interest may be assessed if it is determined that the dispute was not made in
good faith.

- In the event that Developer repowers or replaces the equipment onsite, each Site shall be designated as the "Point of Sale" so as to create an additional local tax-funding source for the County of Imperial.

S-28 ACCESS

This project has identified a second heavy construction equipment/vehicle access via Gray's Wells Road and has a direct connection via the I-8. The route is approximately 27 miles in length. As with the Gordon Wells Road access, this option would require the applicant to obtain appropriate right of way (ROW) approvals from the BLM and approvals from the Border Patrol. This access option

1
2
3
4
5
6
7
8
9
10
11
12
13
14
15
16
17
18
19
20
21
22
23
24
25
26
27
28
29

would utilize a paved frontage road that starts east of the All American Canal and extends east to the existing I-8 rest stop and BLM desert office.

As noted above, either access option (Gordon Wells Road or Grays Wells Road), project access including heavy vehicle access will require approvals by the BLM and Border Patrol/Department of Homeland Security. As indicated in the Draft EIR, the applicant has entered into a Memorandum of Understanding with the U.S Border Patrol setting forth the project-related activities that may occur on this existing dirt road used by the U.S. Border Patrol.

S-29 ACCEPTANCE:

Acceptance of this permit shall be deemed to constitute agreement by Permittee with all terms and conditions herein contained.

The rest of this page is intentionally left blank.

1
2
3
4
5
6
7
8
9
10
11
12
13
14
15
16
17
18
19
20
21
22
23
24
25
26
27
28
29

NOW THEREFORE, County hereby issues the Conditional Use Permit #20-0020, and Permittee hereby accepts such permit upon the terms and conditions set forth herein.

IN WITNESS THEREOF, the parties hereto have executed this Agreement the day and year first written.

PERMITTEE:

Date

COUNTY OF IMPERIAL, a political subdivision of the STATE OF CALIFORNIA

Jim Minnick,
Director, Planning & Development Services
Department

Date

1
2
3
4
5
6
7
8
9
10
11
12
13
14
15
16
17
18
19
20
21
22
23
24
25
26
27
28
29
30

PERMITTEE NOTARIZATION

A notary public or other officer completing this certificate verifies only the identity of the individual who signed the document to which this certificate is attached, and not the truthfulness, accuracy, or validity of that document.

STATE OF CALIFORNIA

COUNTY OF _____ } S.S.

On _____ before me, _____ a Notary Public in and for said County and State, personally appeared _____, who proved to on the basis of satisfactory evidence to be the person(s) whose name(s) is/are subscribed to the within instrument and acknowledged to me that he/she/they executed the same in his/her/their authorized capacity(ies), and that by his/her/their signature(s) on the instrument the person(s), or the entity upon behalf of which the person(s) acted, executed the instrument.

I certify under PENALTY OF PERJURY under the laws of the State of California that the foregoing paragraph is true and correct.

WITNESS my hand and official seal

Signature _____

ATTENTION NOTARY: Although the information requested below is OPTIONAL, it could prevent fraudulent attachment of this certificate to unauthorized document. _____

Title or Type of Document _____
Number of Pages _____ Date of Document _____
Signer(s) Other Than Named Above _____

Dated _____

COUNTY NOTARIZATION

A notary public or other officer completing this certificate verifies only the identity of the individual who signed the document to which this certificate is attached, and not the truthfulness, accuracy, or validity of that document.

1
2
3
4
5
6
7
8
9
10
11
12
13
14
15
16
17
18
19
20
21
22
23
24
25
26
27
28
29

STATE OF CALIFORNIA
COUNTY OF IMPERIAL } S.S.

On _____ before me, _____ a Notary
Public in and for said County and State, personally appeared
_____, who proved to me on the basis of
satisfactory evidence to be the person(s) whose name(s) is/are subscribed to the within instrument
and acknowledged to me that he/she/they executed the same in his/her/their authorized
capacity(ies), and that by his/her/their signature(s) on the instrument the person(s), or the entity
upon behalf of which the person(s) acted, executed the instrument.

I certify under PENALTY OF PERJURY under the laws of the State of California that the
foregoing paragraph is true and correct.

WITNESS my hand and official seal

Signature _____

ATTENTION NOTARY: Although the information requested below is OPTIONAL, it could
prevent fraudulent attachment of this certificate to unauthorized document.

Title or Type of Document _____

Number of Pages _____ Date of Document _____

Signer(s) Other Than Named Above _____

S:\AllUsers\APN\059\300\015\CUP20-0020\PC FOLDER\CUP 20-0020\CUP W CONDITIONS OF APPROVAL\CUP20-0020 Vega SES 4 05 12 23.doc

Attachment F
Planning Commission Package

PROJECT REPORT

TO: **PLANNING COMMISSION**

AGENDA DATE: May 24, 2023

FROM: **PLANNING & DEVELOPMENT SERVICES**

AGENDA TIME 9:00 AM/No.9

PROJECT TYPE: WSA, FEIR, MMRP, CUP #20-0020
VEGA SES 4 Solar Energy Storage Project SUPERVISOR DIST: #5

LOCATION: 2849 East Highway 98, APN: 059-300-015, 017-000
Holtville, CA 92250 PARCEL SIZE: Approx. 450 acres

GENERAL PLAN (existing) Agriculture GENERAL PLAN (proposed) N/A

ZONE (existing) A-3-RE (Heavy Agriculture - Renewable Energy Overlay) ZONE (proposed) N/A

GENERAL PLAN FINDINGS CONSISTENT INCONSISTENT MAY BE/FINDINGS

PLANNING COMMISSION DECISION: HEARING DATE: 05/24/2023

APPROVED DENIED OTHER

PLANNING DIRECTORS DECISION: HEARING DATE: _____

APPROVED DENIED OTHER

ENVIROMENTAL EVALUATION COMMITTEE DECISION: HEARING DATE: N/A

INITIAL STUDY: #20-0029

NEGATIVE DECLARATION MITIGATED NEG. DECLARATION EIR

DEPARTMENTAL REPORTS / APPROVALS:

PUBLIC WORKS	<input type="checkbox"/>	NONE	<input checked="" type="checkbox"/>	ATTACHED
AG	<input type="checkbox"/>	NONE	<input checked="" type="checkbox"/>	ATTACHED
APCD	<input type="checkbox"/>	NONE	<input checked="" type="checkbox"/>	ATTACHED
E.H.S.	<input type="checkbox"/>	NONE	<input checked="" type="checkbox"/>	ATTACHED
FIRE / OES	<input type="checkbox"/>	NONE	<input checked="" type="checkbox"/>	ATTACHED
SHERIFF OFFICE	<input type="checkbox"/>	NONE	<input type="checkbox"/>	ATTACHED
OTHER IID	<input type="checkbox"/>	NONE	<input type="checkbox"/>	ATTACHED

REQUESTED ACTION:

Staff recommends that the Planning Commission hold a public hearing and hear all proponents and opponents of the proposed project. Staff would then recommend that the Planning Commission take the following actions by resolution:

1. Recommend the Board of Supervisors approve the Water Supply Assessment, with findings; and,
2. Recommend the Board of Supervisors Certify of the Final EIR, with findings; and,
3. Recommend the Board of Supervisors adopt the Mitigation Monitoring and Reporting Program; and,
4. Recommend the Board of Supervisors approve Conditional Use Permit #20-0020 (Vega SES 4 Solar Energy Storage Project), with finding.

Planning & Development Services

801 MAIN ST., EL CENTRO, CA 92243 442-265-1736

(Jim Minnick, Director)

S:\AllUsers\APN\059\300\015\CUP#20-0020\PC\FOLDER\CUP 20-0020\PCPROJREPT.docx

PC ORIGINAL PKG

STAFF REPORT
Planning Commission
May 24, 2023
Conditional Use Permit (CUP) #20-0020

SUBJECT:

- A. Water Supply Assessment
- B. Final Environmental Impact Report (SCH #2021050018)
- C. Mitigation Monitoring and Reporting Program with Findings; and
- D. Conditional Use Permit (CUP) #20-0020

Applicant/Owner: APEX Energy Solutions, LLC
604 Sutter Street, Suite 250,
Folsom, CA 95630

PROJECT NAME: VEGA SES 4 SOLAR ENERGY STORAGE PROJECT

Project Location:

The project site is located on approximately 450 acres of privately-owned land in the southernmost portion of Imperial County, California. The project site is between the U.S./Mexico International Border and the All-American Canal, on the California side. The project site is on three parcels (Assessor Parcel Numbers 059-300-015, and 059-300-017-000) that are contiguous with each other. It is approximately 10 miles east of the City of Calexico in Sections 10, 11, 14, 15, and 16 within Township 17 South, and Range 16 East of the San Bernardino Base and Meridian of the Bonds Corner topographic 7.5 minute quadrangle. The project site is located entirely within the County's Renewable Energy Overlay Zone.

Project Summary:

The proposed project consists of three primary components: 1) solar energy generation equipment and associated facilities including a substation and access roads (herein referred to as "solar energy facility"); 2) battery storage system; and, 3) gen-tie line that would connect the proposed on-site substation to the point of interconnection at the existing Imperial Irrigation District's (IID) 92-kV "P" line. The proposed project involves the construction of a 100-megawatt (MW) alternating current (AC) photovoltaic (PV) solar energy facility with an integrated 100 MW battery storage system (not to exceed 200 MW) on approximately 450 acres of land. The project proposes to utilize either thin film or crystalline solar PV technology modules mounted either on fixed frames or horizontal single-axis tracker systems. The project would include electronic/electrical equipment, an on-site substation, access road(s) and fencing. The electrical energy produced by the project would be conducted through the project's interconnection facilities to the proposed

92 kV generator intertie (gen-tie) line and delivered to the existing IID approved point of interconnection on the 92-kV “P” Line.

Land Use Analysis:

The proposed project is located within an unincorporated area of the County. The existing General Plan land use designation is “Agriculture.” The project site is currently zoned A-3-RE (Heavy Agriculture with a Renewable Energy Zone Overlay). Construction of a solar facility with a battery energy storage system (BESS) would be allowed within the existing zoning under an approved Conditional Use Permit.

Surrounding Land Uses, Zoning and General Plan Designations:

DIRECTION	CURRENT LAND USE	ZONING	GENERAL PLAN
Project Site	Vacant	A-3 RE	Agriculture with a Renewable Energy Zone Overlay
North	All American Canal		Agriculture
South	Open Space	Mexico	Agriculture
East	Vacant	BLM	Recreation
West	Agriculture	A-3	Agriculture

Environmental Determination:

On May 4, 2021, the Imperial County Planning Department sent a Notice of Preparation to the California State Clearinghouse (SCH #2021050018) for a 30-day public and agency review ending June 7, 2021 for the start on the preparation of the VEGA 4 Draft Environmental Impact Report (DEIR). Additionally, the County published an NOP in the IV Press on May 4, 2021. A scoping meeting was held to address possible impacts with the public on May 13, 2021.

On November 20, 2022, a Notice of Availability (NOA) for the VEGA 4 Draft EIR was published in the IV Press newspaper. A Notice of Completion with DEIR was sent to State Clearinghouse for agency review for 50 days beginning on November 22, 2022 and ending on January 10, 2023. All significant impacts were addressed in the DEIR.

A Final Environmental Impact Report including an Errata and the Response to Comments received on the DEIR was completed in February of 2023.

Staff Recommendation:

Staff recommends that the Planning Commission hold a public hearing and hear all proponents and opponents of the proposed project. Staff would then recommend that the Planning Commission take the following actions by resolution:

1. Recommend the Board of Supervisors approve the Water Supply Assessment, with findings; and,
2. Recommend the Board of Supervisors Certify of the Final EIR, with findings; and,
3. Recommend the Board of Supervisors adopt the Mitigation Monitoring and Reporting Program; and,
4. Recommend the Board of Supervisors approve Conditional Use Permit #20-0020 (Vega SES 4 Solar Energy Storage Project), with finding.

PREPARED BY: David Black, Project Planner
Planning & Development Services



REVIEWED BY: Michael Abraham, AICP, Assistant Director
Planning & Development Services



APPROVED BY: Jim Minnick, Director
Planning & Development Services



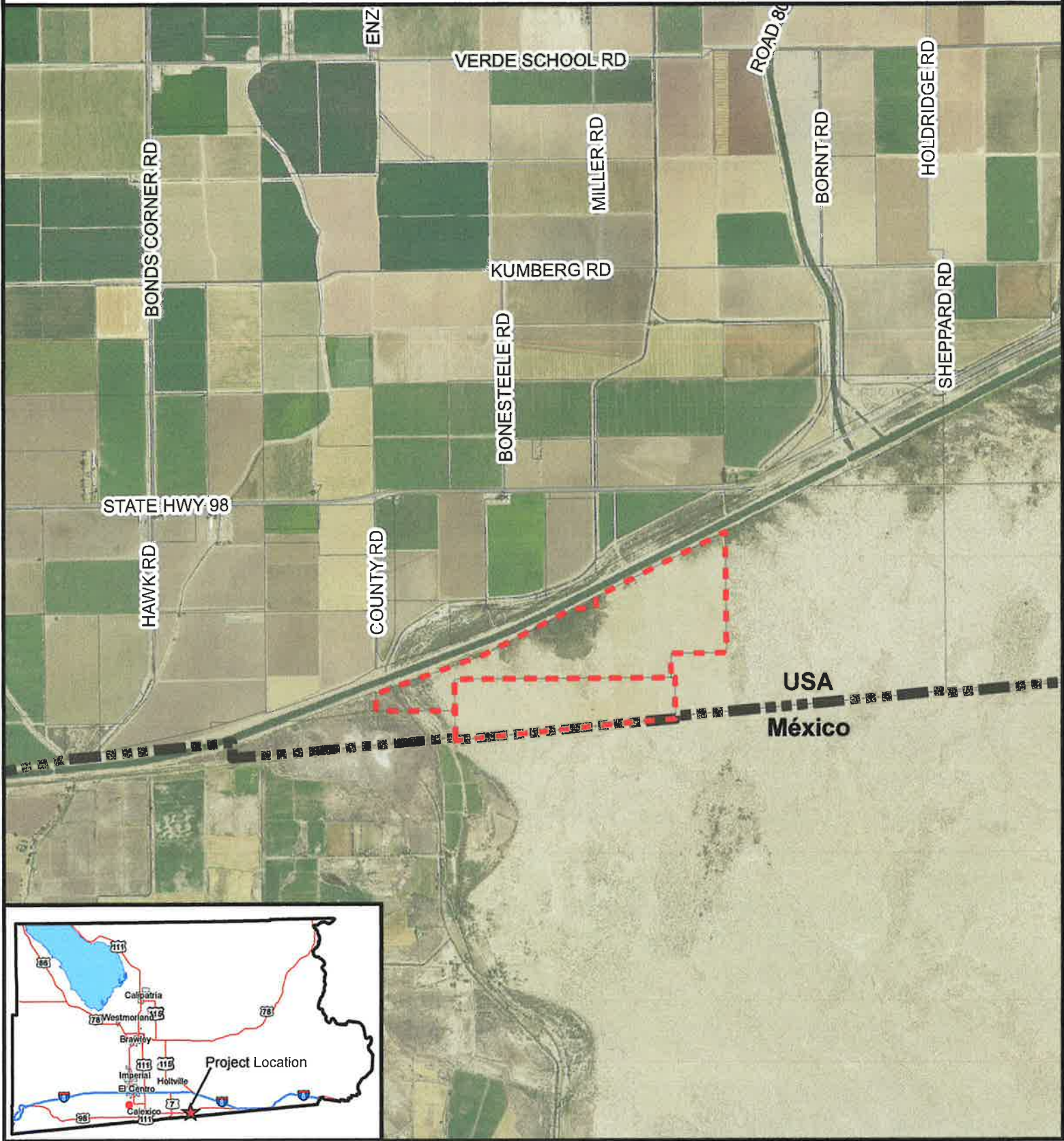
ATTACHMENTS:

- A. Location Maps
- B. Water Supply Assessment
- C. Final EIR Finding of Fact/Errata
- D. Mitigation Monitoring and Reporting Program
- E. Conditional Use Permit CUP #20-0020
- F. Final EIR

S/db/059/300/015/cup20 0020/pcfolder/staffreport

**Attachment A:
Location Map**

PROJECT LOCATION MAP



**APEX ENERGY SOLUTIONS LLC,
(VEGA4)
CUP #20-0020
APN 059-300-015 AND 059-300-017-000**

PC ORIGINAL PKG

	Project Location
	International Boundary
	Parcels
	Centerline



Project Components

Solar Energy Facility

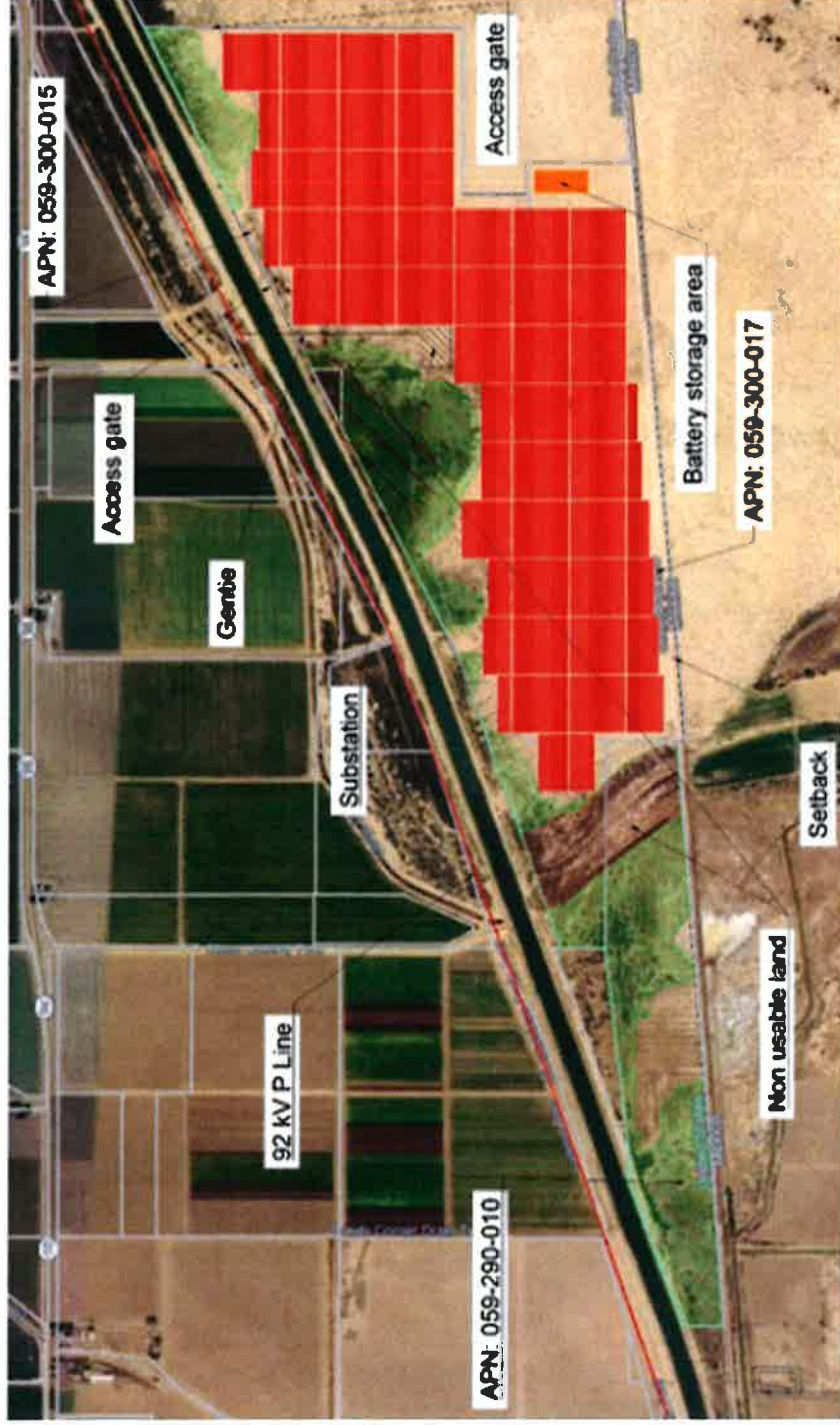
- Up to 100 MW AC Generation
- Solar Panels/Arrays
- Substation
- Switching Station
- Fencing
- Access Roads

Battery Storage System

- Up to 100 MW of storage (not to exceed 200 MW)

Gen-Tie Line

- 92-kV
- Interconnect to Imperial Irrigation District's 92-kV "P" Line





PC ORIGINAL PKG

Attachment B:
WSA

PC ORIGINAL PKG

RESOLUTION NO.

A RESOLUTION OF THE PLANNING COMMISSION OF THE COUNTY OF IMPERIAL, CALIFORNIA, RECOMMENDING APPROVAL OF THE WATER SUPPLY ASSESSEMENT FOR THE VEGA SES 4 SOLAR ENERGY STORAGE PROJECT TO THE BOARD OF SUPERVISORS.

WHEREAS, the VEGA SES 4 Solar Energy Project qualifies as a “project” under the Water Code triggering the need to prepare a Water Supply Assessment because it proposed to a demand of water equivalent to, or greater than, the amount of water required by a 500 dwelling unit project, and/or because it is a proposed industrial use occupying more than 40 acres of land. The Water Supply Assessment (WSA) has been prepared in accordance with Water Code 10912(c) (4); and,

WHEREAS, the Imperial County Board of Supervisors has the authority and responsibility for approving the Water Supply Assessment; and,

WHEREAS, the duty to prepare a Water Supply Assessment falls to the County of Imperial (“County”) because the Imperial Irrigation District (IID) is not a public water system within the meaning of the Water Code 10912(c); and,

WHEREAS, the County, in consultation with an expert engineering firm and the IID prepared the Water Supply Assessment , which includes any and all Water Supply Assessment addendums; and,

WHEREAS, the County has independently reviewed and considered the Water Supply Assessment and the entire administrative record, and;

WHEREAS, public notice of said application has been given, and the Planning Commission has considered evidence presented by the Imperial County Planning & Development Services Department and other interested parties at a public hearing held with respect to this item on May 24, 2023; and,

NOW THEREFORE, the Planning Commission of the County of Imperial **DOES HEREBY RECOMMEND APPROVAL TO THE BOARD OF SUPERVISORS BASED ON THE FOLLOWING FINDINGS FOR THE WSA** as follows:

SECTION 1. The Planning Commission has considered the proposed VEGA SES 4 SOLAR ENERGY STORAGE PROJECT’S WSA prior to making a decision to recommend approval of the proposed WSA. The Planning Commission finds and determines that the WSA is adequate and prepared in accordance with the requirements of Water Code, Section 10912(c)(4) and the analysis of the WSA demonstrates that the total projected water supplies, determined to be available by the County for the Project during normal, single dry, and multiple dry water years, will meet the projected water demand associated with the proposed project and based upon the following findings and determinations.

SECTION 2. That in accordance with State Planning and Zoning law, the County Planning Commission makes the following findings for the approval of the VEGA SES 4 SOLAR ENERGY project:

1. This Water Supply Assessment has determined that IID has adequate polices, programs and projects in place to provide water to agricultural, commercial, industrial and municipal users in the Imperial Unit. Adequate supply is currently available as well as during normal water years. IID's Equitable Distribution Plan ("EDP") is sufficient to manage water supply during multiple dry water years. Conservation plans and measures are available to reduce the probability of Supply Demand Imbalance ("SDI") from occurring. Adequate agreements, plans and policies are in place that enable the Imperial Unit water supply to be considered reliable for 40 years.
2. IID serves as the regional water supplier, importing raw Colorado River water and delivering it, untreated, to agricultural, municipal, and industrial water users within its Service Area.
3. IID is a raw water retailer and a domestic raw water wholesaler, and does not supply potable drinking water.
4. This WSA has shown that IID water supply is adequate for the operations of this Project. IID's IWSP for Non-Agricultural Projects dedicates 25,000 AFY of IID's annual water supply to serve new projects. To date 23,800 AF per year remain available for new industrial projects ensuring reasonably sufficient supplies for new non-agricultural water users and the request for 11 acres feet of water per year is within the remaining balance available.
5. As urban growth continues in Imperial County, agricultural water use may decline due to the transfer of water consumption to other land uses.
6. In the case of a SDI, IID's EDP gives water delivery priority to municipal and industrial users over agricultural users.

NOW, THEREFORE, based on the above findings, the Planning Commission of the County of Imperial **DOES HEREBY** recommend approval to the Board of Supervisors for the proposed Water Supply Assessment for VEGA SES 4 SOLAR ENERGY Project.

Rudy Schaffner, Chairman
Imperial County Planning Commission

I hereby certify that the preceding resolution was taken by the Planning Commission at a meeting conducted on **May 24, 2023** by the following vote:

AYES:

NOES:

ABSENT:

ABSTAIN:

ATTEST:

James Minnick, Secretary of the
Planning Commission/Director of Planning

S:\APN\059 300 015\cup20 0020\PC FOLDER\WSA\Resolution Water Supply Assessment.docx

SB 610 - Water Supply Assessment
For
VEGA SES 4 Solar Energy Storage Project

June 11, 2021

Prepared For:

Imperial Irrigation District
333 East Barioni Boulevard
Imperial, California 92251

VEGA SES 4 Solar Energy Storage Project

Contents

- To properly update automated fields and TOC – Highlight (Select) entire WSA document and Select F9 and then select update entire table for the TOC, list of Figures and list of Tables, when prompted.

PURPOSE OF WATER SUPPLY ASSESSMENT	6
Project Determination According to SB 610 - Water Supply Assessment	6
EXECUTIVE SUMMARY	8
PROJECT DESCRIPTION	9
Description of IID Service Area	13
Climate Factors	13
Imperial Valley Historic and Future Land and Water Uses.....	17
Imperial Integrated Regional Water Management Plan (October 2012).....	18
IID Interim Water Supply Policy for Non-Agricultural Projects (September 2009)	20
IID Temporary Land Conversion Following Policy (May 2012).....	21
IMPERIAL IRRIGATION DISTRICT’S WATER RIGHTS	22
California Law	22
Law of the River	23
IMPERIAL IRRIGATION DISTRICT WATER SUPPLY AND DEMAND	32
WATER AVAILABILITY – NORMAL YEAR	33
EXPECTED WATER AVAILABILITY – SINGLE DRY AND MULTIPLE DRY YEARS.....	35
Equitable Distribution Plan (EDP)	36
Water Management under Inadvertent Overrun Payback Policy (IOPP).....	37
PROJECT WATER AVAILABILITY FOR A 20-YEAR PERIOD TO MEET PROJECTED DEMANDS.....	38
EXPECTED WATER DEMANDS FOR THE PROPOSED PROJECT.....	40
IID’S ABILITY TO MEET DEMANDS WITH WATER SUPPLY	41
Expanding Water Supply Portfolio.....	44
IID Near Term Water Supply Projections.....	46
IMPERIAL IRRIGATION DISTRICT FINDINGS	47
ASSESSMENT CONCLUSION	49
RESOURCES AND REFERENCES	50
ATTACHMENTS	51

Figures

Figure 1. Project Site Regional Location.....	10
Figure 2. Aerial Map of Project Vicinity	11
Figure 3. Project Layout/Site Plan	12
Figure 4. IID Imperial Unit Boundary and Canal Network	14
Figure 5. Major Colorado River Reservoir Storage Facilities and Basin Location Map.....	29
Figure 6. Lake Mead Water Elevation Levels 2020 visit< http://www.arachnoid.com/NaturalResources/index.html >	32
Figure 7. Lake Mead IOPP Schematic.....	37

Tables

Table 1. Climate Characteristics, Imperial, CA 100-Year Record, 1921-2020.....	15
Table 2. IID Areawide Annual Precipitation (In), (1991-2019)	15
Table 3. Monthly Mean Temperature (°F) – Imperial, CA 10-Year, 30-Year & 100-Year (2011-2020, 1991-2020, 1921-2020)	16
Table 4. Monthly Mean Rainfall (In) – Imperial, CA 10-Year, 30-Year & 100-Year (2011-2020, 1991-2020, 1921-2020)	16
Table 5. Non-Agricultural Water Demand within IID Water Service Area, 2015-2055 (KAFY)	19
Table 6. Historic and forecasted Agricultural Water Consumptive Use and Delivery Demand within IID Water Service Area, 2015-2055 (KAFY)	20
Table 7. IID System Operations Consumptive Use within IID Water Service Area and from AAC at Mesa Lateral 5 to Imperial Dam, (KAF), 2020	20
Table 8. Interim Water Supply Policy 2021 Annual Non-Agricultural Water Supply Development Fee Schedule	21
Table 9. CRWDA Annual 4.4 MAF Apportionment (Priorities 1 to 4) for California Agencies (AFY).....	27
Table 10. Unregulated Inflow to Lake Powell, Percent of Historic Average, 2000-2020.....	28
Table 11. IID Historic and Forecast Net Consumptive Use for Normal Year, Single-Dry Year and Multiple-Dry Year Water Supply, 2003-2037, et seq. (CRWDA Exhibit B)	33
Table 12. IID Annual Rainfall (In), Net Consumptive Use and Underrun/Overrun Amounts (AF), 1988-2020.....	35
Table 13. IID Inadvertent Overrun Payback to the Colorado River under the IOPP, 2012-2020.....	38
Table 14. Project Water Uses (AFY)	40
Table 15. IID System Operations Consumptive Use within IID Water Service Area and from AAC at Mesa Lateral 5 to Imperial Dam, (KAF), 2020	41
Table 16. IID Historic and Forecasted Consumptive Use vs CRWDA Exhibit B IID Net Available Consumptive Use, volumes at Imperial Dam (KAFY), 2015-2055 Next Update in 2021 thru 2020	42
Table 17. 2020 Approved Water Order, Actual CU (Decree Accounting Report) and IID Underrun, KAF at Imperial Dam	42
Table 18. IID Capital Project Alternatives and Cost (May 2009 price levels \$).....	45

Attachments

Attachment A: IID Interim Water Supply Policy for Non-Agricultural Projects

Acronyms

AF	Acre-Foot or Acre-Feet
AFY	Acre-Feet per Year
AOP	Annual Operations Plan
CAP	Central Arizona Project
CDCR	California Department of Corrections and Rehabilitation
CDPH	California Department of Public Health
CDWR	California Department of Water Resources
CEQA	California Environmental Quality Act
CRWDA	Colorado River Water Delivery Agreement
CUP	Conditional Use Permit
CVWD	Coachella Valley Water District
EDP	IID Equitable Distribution Plan
EIS	Environmental Impact Statement
ICPDS	Imperial County Planning and Development Services
ICS	Intentionally Created Surplus
IID	Imperial Irrigation District
IOPP	Inadvertent Overrun Payback Policy
ISG	Interim Surplus Guidelines
IRWMP	Integrated Regional Water Management Plan
IWSP	Interim Water Supply Policy
KAF	Thousand Acre Feet
LAFCO	Local Agency Formation Commission
LCR	Lower Colorado Region
MCI	Municipal, commercial, industrial
MGD	Million Gallons per Day
MW	Megawatt
MWD	Metropolitan Water District of Southern California
NAF	Naval Air Facility
PVID	Palo Verde Irrigation District
QSA/	Quantification Settlement Agreement and Related Agreements
TA	Transfer Agreements
SB	Senate Bill
SDCWA	San Diego County Water Authority
SNWA	Southern Nevada Water Authority
TLCFP	Temporary Land Conversion Following Policy
USBR	United States Bureau of Reclamation
USEPA	United States Environmental Protection Agency
WSA	Water Supply Assessment
CWC	California Water Code

PURPOSE OF WATER SUPPLY ASSESSMENT

This Water Supply Assessment (WSA) was prepared for the Imperial Irrigation District (Lead Agency) by ECORP Consulting, Inc., regarding the Vega SES 4, LLC VEGA SES 4 Solar Energy Storage Project (the “Applicant”). This study is a requirement of California law, specifically Senate Bill 610 (referred to as SB 610). SB 610 is an act that amended Section 21151.9 of the Public Resources Code, and Sections 10631, 10656, 10910, 10911, 10912, and 10915 of the Water Code. SB 221 is an act that amended Section 11010 of the Business and Professions Code, while amending Section 65867.5 and adding Sections 66455.3 and 66473.7 to the Government Code. SB 610 was approved by the Governor and filed with the Secretary of State on October 9, 2001, and became effective January 1, 2002.¹ SB 610 requires a lead agency, to determine that a project (as defined in CWC Section 10912) subject to California Environmental Quality Act (CEQA), to identify any public water system that may supply water for the project and to request the applicants to prepare a specified water supply assessment.

This study has been prepared pursuant to the requirements of CWC Section 10910, as amended by SB 610 (Costa, Chapter 643, Stats. 2001). The purpose of SB 610 is to advance water supply planning efforts in the State of California; therefore, SB 610 requires the Lead Agency, to identify any public water system or water purveyor that may supply water for the project and to prepare the WSA after a consultation. Once the water supply system is identified and water usage is established for construction and operations for the life of the project, the lead agency is then able to coordinate with the local water supplier and make informed land use decisions to help provide California’s cities, farms and rural communities with adequate water supplies.

Under SB 610, water supply assessments must be furnished to local governments for inclusion in any environmental documentation for certain projects (as defined in California Water Code (CWC) Section 10912 [a]) that are subject to the California Environmental Quality Act (CEQA). Due to increased water demands statewide, this water bill seeks to improve the link between information on water availability and certain land use decisions made by cities and counties. This bill takes a significant step toward managing the demand placed on California’s water supply. It provides further regulations and incentives to preserve and protect future water needs. Ultimately, this bill will coordinate local water supply and land use decisions to help provide California’s cities, farms, rural communities and industrial developments with adequate long-term water supplies. The WSA will allow the lead agency to determine whether water supplies will be sufficient to satisfy the demands of the project, in addition to existing and planned future uses.

Project Determination According to SB 610 - Water Supply Assessment

With the introduction of SB 610, any project under the California Environmental Quality Act (CEQA) shall provide a Water Supply Assessment if the project meets the definition of CWC § 10912. Water Code

¹SB 610 amended Section 21151.9 of the California Public Resources Code, and amended Sections 10631, 10656, 10910, 10911, 10912, and 10915, repealed Section 10913, and added and amended Section 10657 of the Water Code. SB 610 was approved by California Governor Gray Davis and filed with the Secretary of State on October 9, 2001.

section 10911(c) requires for that the lead agency “determine, based on the entire record, whether projected water supplies will be sufficient to satisfy the demands of the project, in addition to existing and planned future uses.” Specifically, Water Code section 10910(c)(3) states that “If the projected water demand associated with the proposed project was not accounted for in the most recently adopted urban water management plan, or the public water system has no urban water management plan, the water supply assessment for the project shall include a discussion with regard to whether the total projected water supplies, determined to be available by the city or county for the project during normal, single dry, and multiple dry water years during a 20 year projection, will meet the projected water demand associated with the proposed project, in addition to the public water system’s existing and planned future uses, including agricultural and manufacturing uses.”

After review of CWC § 10912a, and Section 10912 (a)(5)(B), it was determined that the Vega SES 4, LLC VEGA SES 4 Solar Energy Storage Project is deemed a project as it is considered an industrial use that will occupy more than 40 acres of land.

EXECUTIVE SUMMARY

Imperial Irrigation District has requested a WSA as part of the environmental review for the proposed Vega SES 4, LLC VEGA SES 4 Solar Energy Storage Project ("Project"). This study is intended for use by Imperial County Planning and Development Services in its evaluation of water supplies for existing and future land uses. The evaluation examines the following water elements:

- Water availability during a normal year
- Water availability during a single dry year, and multiple dry water years
- Water availability during a 20-year projection to meet existing demands
- Expected 20-year water demands of the Project
- Reasonably foreseeable planned future water demands to be served by the Imperial Irrigation District

The proposed Project site is located within Imperial Irrigation District's (IID) Imperial Unit and district boundary and as such is eligible to receive water service. IID has adopted an Interim Water Supply Policy (IWSP) for Non-Agricultural Projects, from which water supplies can be contracted to serve new developments within IID's water service area. For applications processed under the IWSP, applicants shall be required to pay a processing fee and, after IID board approval of the corresponding agreement, will be required to pay a reservation fee(s) and annual water supply development fees.

The IWSP sets aside 25,000 acre-feet annually (AFY) of IID's Colorado River water supply to serve new non-agricultural projects. As of April 2021, a balance of 23,800 AFY remain available under the IWSP for new non-agricultural projects ensuring reasonably sufficient supplies for such projects. The proposed Project water demand of approximately 275 AF during an 18-month construction period and up to 10 AF/year for ongoing operations during the 30-year projected Project life represents 1.2% and 0.4 % of the annual unallocated supply set aside for new non-agricultural projects. Thus, the proposed Project's estimated water demand would not affect IID's ability to provide water to other users in IID's water service area.

PROJECT DESCRIPTION

Vega SES 4, LLC is proposing to construct and operate a solar energy generation and storage facility on approximately 531.53 acres of private lands in the Imperial Valley in Imperial County. The Project would be located between the California/Mexico border and the All-American Canal, on the California side. It is approximately 10 miles east of Calexico in Sections 10, 11, 14, 15, and 16 of Township 17 South, Range 16 East of the San Bernardino Base and Meridian (SBB&M) of the “Bonds Corner” 7.5-minute topographic quadrangle. The Project would be located on Imperial County Assessor’s Parcel Numbers (APNs) 059-300-015-000 (approximately 301.73 acres), 059-300-017-000 (approximately 148.88 acres) and 059-290-010-000 (approximately 80.92 acres), all of which are currently owned by Tammy Cheri Slater and Jimmie R. Doyle (co-trustees of the Survivors Trust under the Doyle Family 2010 Trust dated August 13, 2010). (Figure 1. Site Regional Location, and Figure 2. Aerial View of Project Site and Vicinity). The Project would include approximately 313,600 photovoltaic solar cells, approximately 135 energy storage battery containers, and related electrical power interconnection and transmission facilities. The electrical energy produced by the Project would be conducted through the proposed 92 kilovolt (kV) generator intertie (“gen-tie”) line and delivered to the Imperial Irrigation District (IID) 92 kV “P” line. (Figure 3. Project Layout/Site Plan).

The solar energy storage facility involves a Conditional Use Permit from Imperial County that will allow for construction and operation of the Project over its projected 30-year duration.

Domestic water and sanitation facilities would be required during construction. These would be provided through bottled water and portable facilities. A domestic/potable water connection would not be required.

The Project will need to contract with IID to deliver up to 275 AF of untreated water during the 18-month construction phase for dust control and soil conditioning, and up to 10 AFY of untreated water during the operation phase to wash the PV modules. Untreated water would be provided via the All American Canal. It is anticipated that water would be pumped directly into water trucks from the canal.

This WSA does not include an analysis of water supply for any other ancillary uses, including temporary potable and sanitary supply during the 18-month construction period.

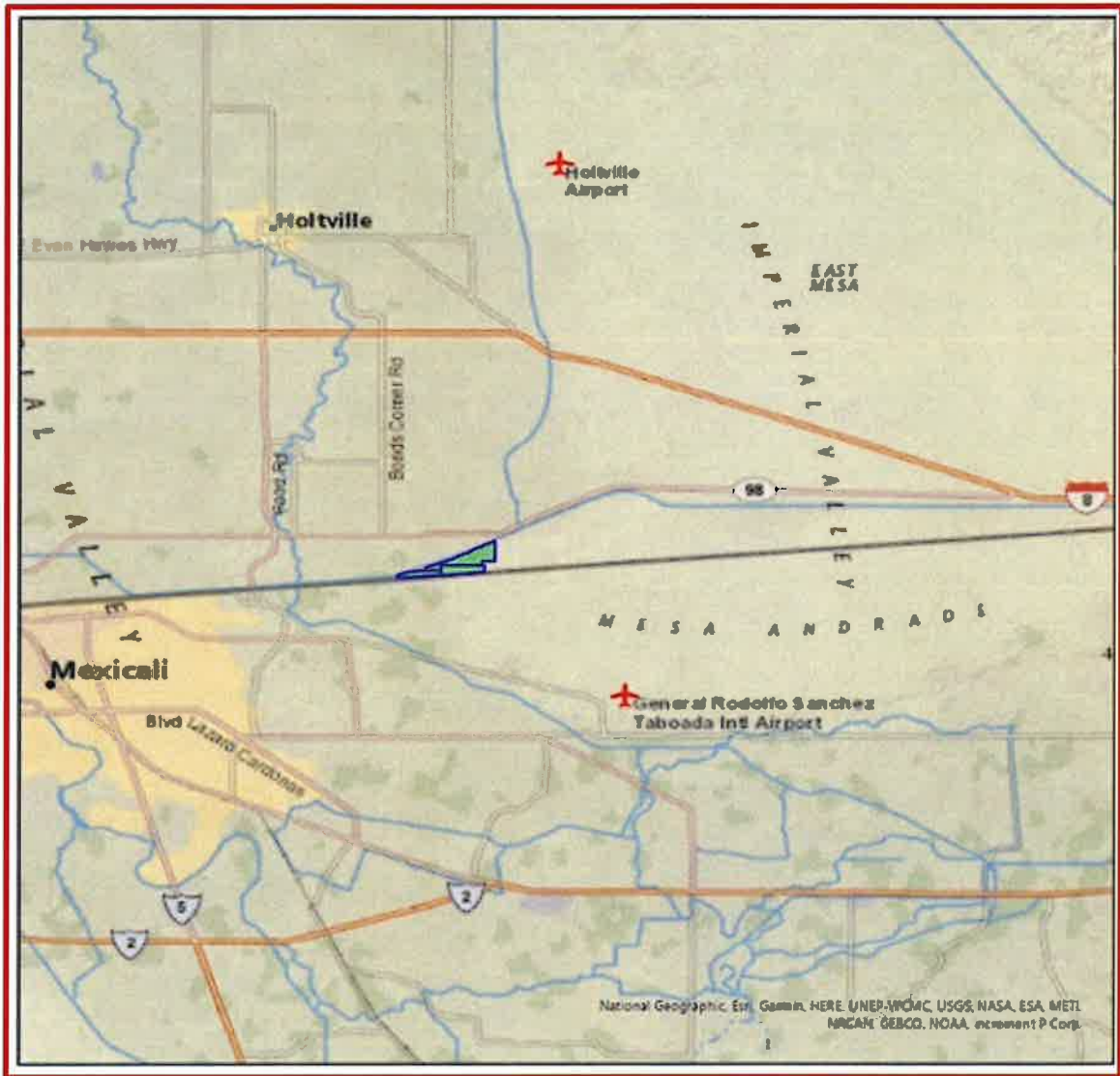


Figure 1. Project Site Regional Location

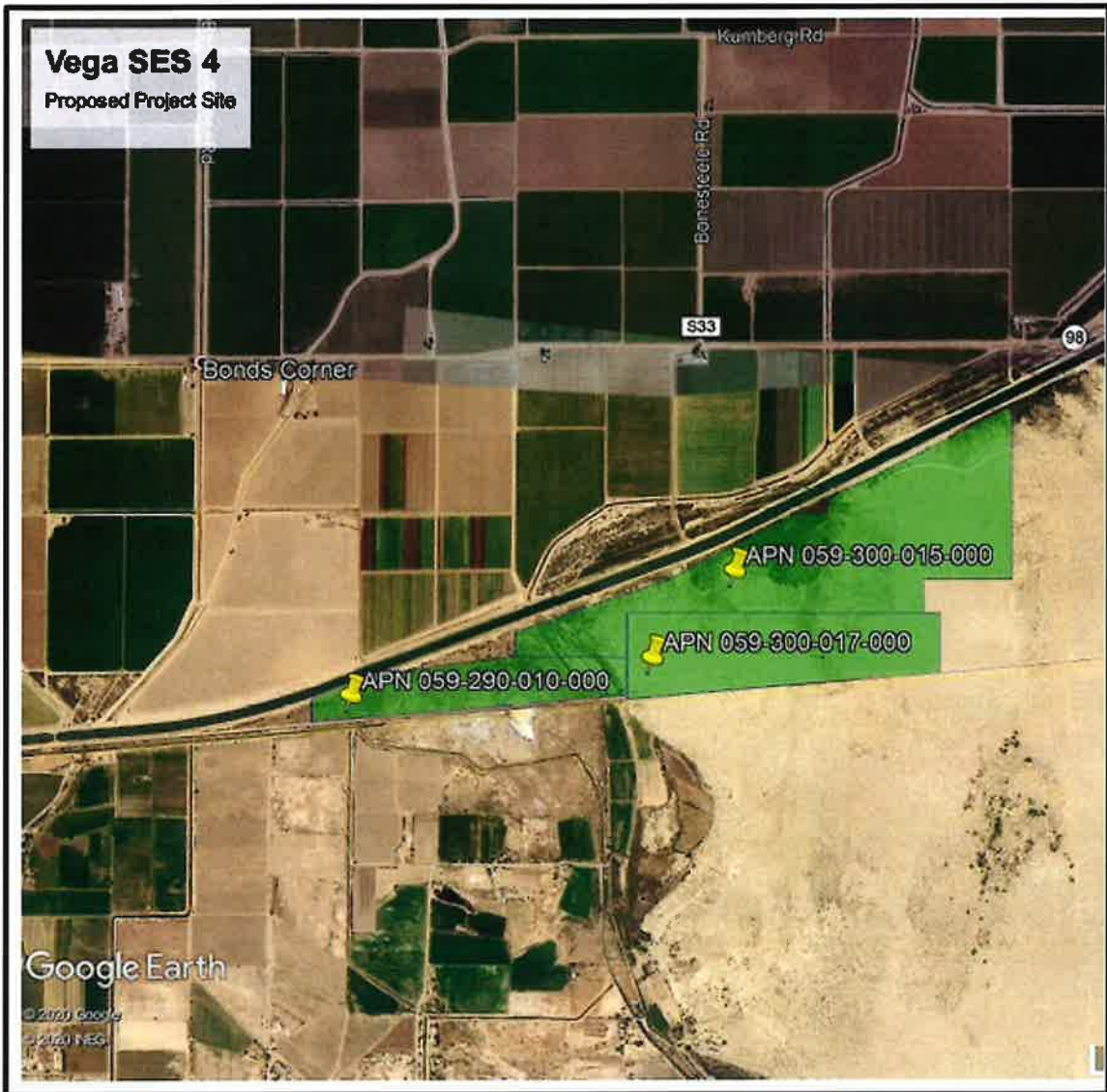


Figure 2. Aerial Map of Project Vicinity

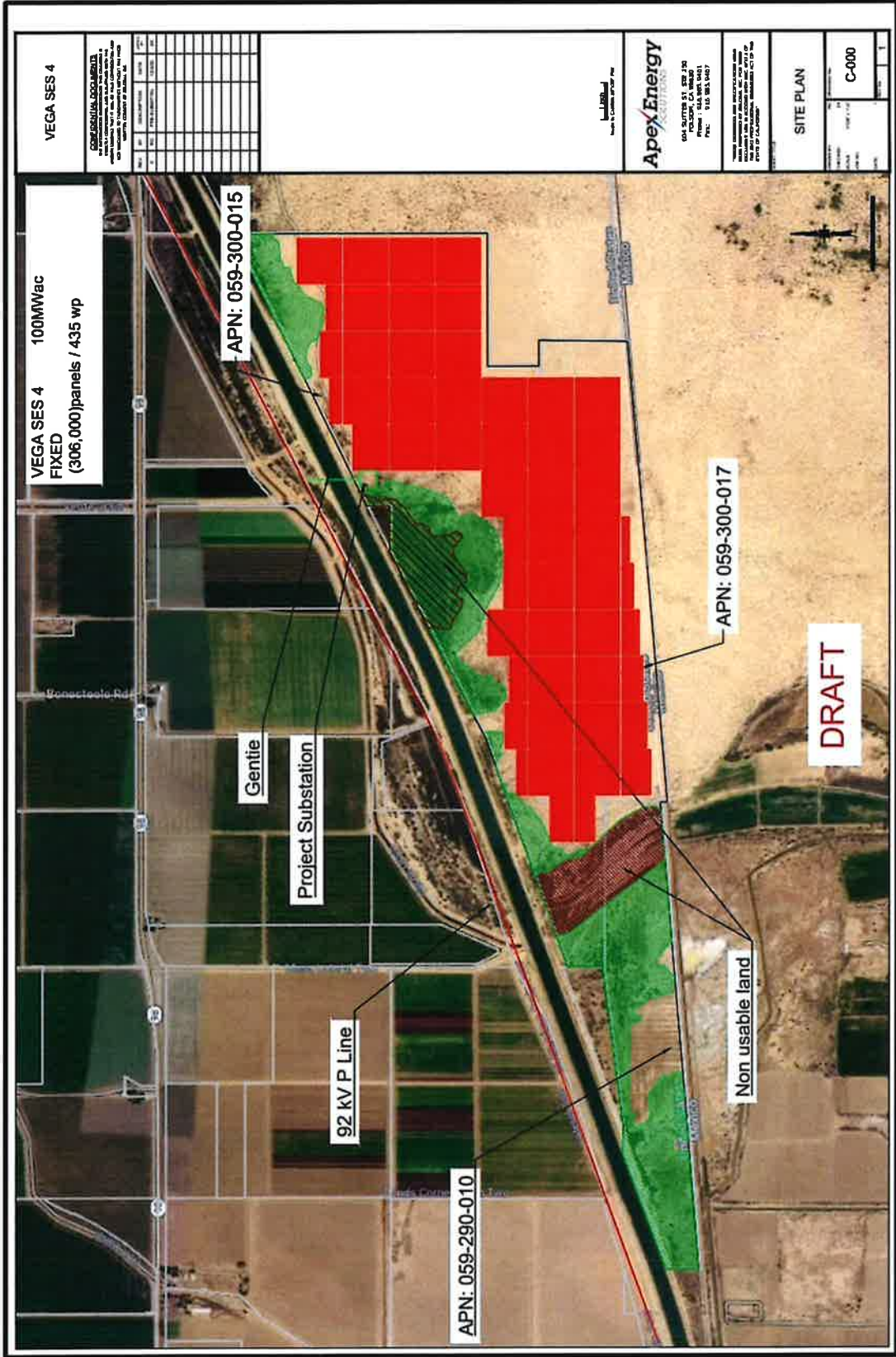


Figure 3. Project Layout/Site Plan

Description of IID Service Area

The proposed Project site is located in Imperial County in the southeastern corner of California. The County is comprised of approximately 4,597 square miles or 2,942,080 acres.² Imperial County is bordered by San Diego County to the west, Riverside County to the north, the Colorado River/Arizona boundary to the east, and 84 miles of International Boundary with the Republic of Mexico to the south. Approximately fifty percent of Imperial County is undeveloped land under federal ownership and jurisdiction. The Salton Sea accounts for approximately 11 percent of Imperial County's surface area. In 2020, sixteen percent (16%) of the area was in irrigated agriculture (466,325 acres), including 14,676 acres of the Yuma Project, some 35 sections or 5,600 acres served by Palo Verde Irrigation District (PVID), and 446,049 acres served by IID.³

The area served by IID is located in the Imperial Valley, which is generally contiguous with IID's Imperial Unit, lies south of the Salton Sea, north of the U.S./Mexico International Border, and generally in the 658,942 acre area between IID's Westside Main and East Highline Canals.⁴ In 2020, IID delivered untreated water to 494,921 net irrigated acres, predominantly in the Imperial Valley, along with small areas of East and West Mesa land.

The developed area consists of seven incorporated cities (Brawley, Calexico, Calipatria, El Centro, Holtville, Imperial and Westmorland), three unincorporated communities (Heber, Niland and Seeley), and three institutions (Naval Air Facility [NAF] El Centro, Calipatria CDCR, and Centinela CDCR) and supporting facilities. **Figure 4** provides a map of the IID Imperial Unit boundary, as well as cities, communities and main canals.

Climate Factors

Imperial Valley, located in the Northern Sonoran Desert, which has a subtropical desert climate is characterized by hot, dry summers and mild winters. Clear and sunny conditions typically prevail, and frost is rare. The region receives 85 to 90 percent of possible sunshine each year, the highest in the United States. Winter temperatures are mild rarely dropping below 32°F, but summer temperatures are very hot, with more than 100 days over 100°F each year. The remainder of the year has a relatively mild climate with temperatures averaging in the mid-70s.

The 100-year average climate characteristics are provided in **Table 1**. Rainfall contributes around 50,000 AF of effective agricultural water per inch of rain. Most rainfall occurs from November through March; however, summer storms can be significant in some years. Annual areawide rainfall is shown in **Table 2**.

² *Imperial County General Plan, Land Use Element 2008 Update*

³ *USBR website: Yuma Project. 7 June 2017, PVID contact for acreage. 26 April 2021.*

⁴ *IID Annual Inventory of Areas Receiving Water Years 2020, 2019, 2018*

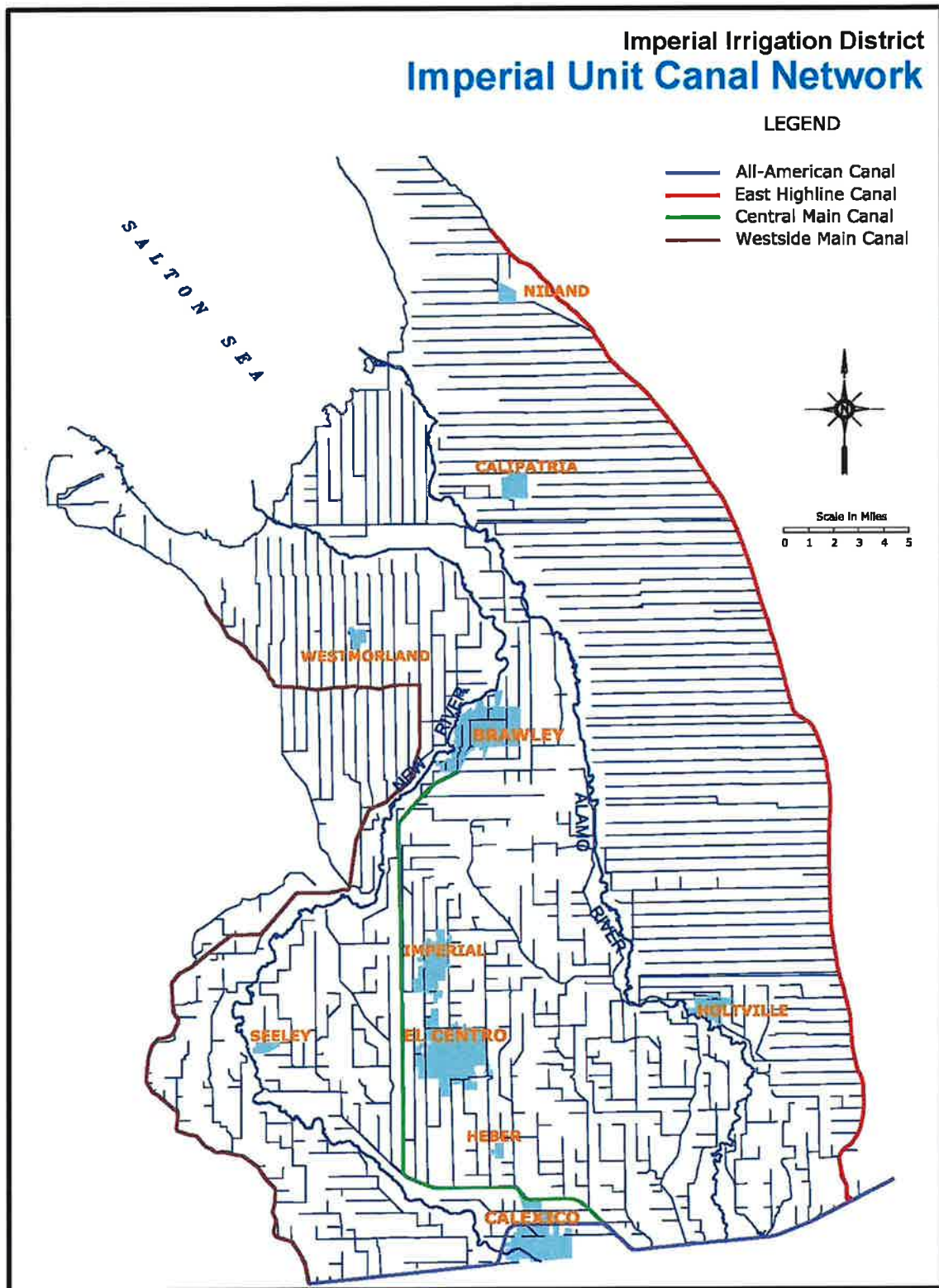


Figure 4. IID Imperial Unit Boundary and Canal Network

The thirty-year, 1991-2020, average annual air temperature was 73.7°F, and average annual rainfall was 2.70 inches, see Table 3 and Table 4. This record shows that while average annual rainfall has fluctuated, the 10-year average temperatures have slightly increased over the 30-year averages.

Table 1. Climate Characteristics, Imperial, CA 100-Year Record, 1920-2020

Climate Characteristic	Annual Value
Average Precipitation (100-year record, 1921-2020)	2.79 inches (In)
Minimum Temperature, Jan 1937	16 °F
Maximum Temperature, July 1995	121 °F
Average Minimum Temperature, 1921-2020	48.2 °F
Average Maximum Temperature, 1921-2020	98.3 °F
Average Temperature, 1921-2020	73.0 °F

Source: IID Imperial Weather Station Record

Table 2. IID Areawide Annual Precipitation (In), (1990-2020)

1990	1991	1992	1993	1994	1995	1996
1.646	3.347	4.939	2.784	1.775	1.251	0.685
1997	1998	1999	2000	2001	2002	2003
1.328	2.604	1.399	0.612	0.516	0.266	2.402
2004	2005	2006	2007	2008	2009	2010
4.116	4.140	0.410	1.331	1.301	0.619	3.907
2011	2012	2013	2014	2015	2016	2017
2.261	2.752	2.772	1.103	2.000	1.867	2.183
2018	2019	2020				
1.305	3.017	2.673				

Source: Computation based on polygon average of CIMIS as station came online in the WIS.⁵

Notable from Table 2 (above) and Table 3 (below) is that while average annual rainfall measured at IID Headquarters in Imperial, California, has been decreasing, monthly average temperatures are remarkably consistent.

⁵ From 1/1/1990-3/23/2004, 3 CIMIS stations: Seeley, Calipatria/Mulberry, Meloland; 3/24/2004-7/5/2009, 4 CIMIS stations (added Westmorland N.); 7/6/2009-12/1/2009, 3 CIMIS stations: Westmorland N. offline; 12/2/2009-2/31/2009, 4 CIMIS stations, Westmorland N. back online; 1/1/2010-9/20/2010.

Table 3. Monthly Mean Temperature (°F) – Imperial, CA 10-Year, 30-Year & 100-Year (2011-2020, 1991-2020, 1921-2020)

	Jan			Feb			Mar			Apr		
	Max	Min	Avg	Max	Min	Avg	Max	Min	Avg	Max	Min	Avg
10-year	82	32	57	84	35	60	93	42	67	100	47	73
30-year	81	34	57	84	37	60	92	41	66	99	47	71
100-year	80	31	55	86	34	60	91	40	64	99	46	71
	May			Jun			Jul			Aug		
	Max	Min	Avg	Max	Min	Avg	Max	Min	Avg	Max	Min	Avg
10-year	105	53	76	115	61	87	115	70	92	114	70	92
30-year	105	54	78	112	60	86	115	68	92	114	69	92
100-year	105	53	78	113	59	86	114	68	92	113	68	92
	Sep			Oct			Nov			Dec		
	Max	Min	Avg	Max	Min	Avg	Max	Min	Avg	Max	Min	Avg
10-year	111	62	87	101	52	76	91	39	64	80	32	55
30-year	110	62	87	102	50	76	90	39	64	79	32	55
100-year	110	60	86	101	49	75	89	38	63	80	32	56

Source: IID Imperial Headquarters Station Record (Data provided by IID staff)

Table 4. Monthly Mean Rainfall (In) – Imperial, CA 10-Year, 30-Year & 100-Year (2011-2020, 1991-2020, 1921-2020)

	Jan	Feb	Mar	Apr	May	Jun	Jul	Aug	Sep	Oct	Nov	Dec	Annual
10-year	0.33	0.26	0.22	0.12	0.08	0.01	0.22	0.30	0.28	0.02	0.26	0.42	2.44
30-year	0.50	0.43	0.31	0.09	0.06	0.00	0.14	0.19	0.26	0.15	0.22	0.40	2.70
100-year	0.39	0.38	0.25	0.11	0.03	0.00	0.12	0.33	0.36	0.25	0.21	0.51	2.79

Source: IID WIS: CIMIS stations polygon calculation (Data provided by IID staff).

Imperial Valley depends on the Colorado River for its water, which IID transports, untreated, to delivery gates for agricultural, municipal, industrial (including geothermal and solar energy), environmental (managed marsh), recreational (lakes), and other non-agricultural uses. IID supplies the cities, communities, institutions and Golden State Water (which includes all or portions Calipatria, Niland, and some adjacent Imperial County territory) with untreated water that they treat to meet state and federal drinking water guidelines before distribution to their customers. Industries outside the municipal areas treat the water to required standards of their industry. To comply with U.S. Environmental Protection Agency (USEPA) requirements and avoid termination of canal water service, residents in the IID water service area who do not receive treated water service must obtain alternative water service for drinking and cooking from a state-approved provider. To avoid penalties that could exceed \$25,000 a day, IID strictly enforces this rule. The IID Water Department tracks nearly 3,000 raw water service accounts required by the California Department of Public Health (CDPH) to have alternate state approved drinking water service. IID maintains a small-acreage pipe and drinking water database and provides an annual compliance update to CDPH.

Imperial Valley Historic and Future Land and Water Uses

Agricultural development in the Imperial Valley began at the turn of the twentieth century. In 2019, gross agricultural production for Imperial County was valued at \$2,015,843,000, of which approximately \$1,693,308,120 was produced in the IID water service area.⁶ While the agriculture-based economy is expected to continue, land use is projected to change somewhat over the years as industrial and/or alternative energy development and urbanization occur in rural areas and in areas adjacent to existing urban centers, respectively.

Imperial Valley's economy is gradually diversifying. Agriculture will likely continue to be the primary industry within the valley; however, two principal factors anticipated to reduce crop acreage are renewable energy (geothermal and solar) and urban development. Over the next twenty years, urbanization is expected to slightly decrease agriculture land use to provide space for an increase in residential, commercial and industrial uses. The transition from agricultural land use typically results in a net decrease in water demand for municipal, commercial, and solar energy development; and a net increase in water demand for geothermal energy development. Local energy resources include geothermal, wind, biomass and solar. The County General Plan provides for development of energy production centers or energy parks within Imperial County. Alternative energy facilities will help California meet its statutory and regulatory goals for increasing renewable power generation and use and decrease water demands in Imperial County.

The VEGA SES 4 Solar Storage Project is not located on land that is currently used for agriculture. Thus, the Project would not reduce agricultural production in the County. Apex Energy Solutions, LLC has identified the following additional objectives to complement the primary purpose of the Project:

- Assist California in meeting its current and future Renewable Portfolio Standard Goals.
- Site the Project in an area with excellent solar energy resources in order to maximize productivity.
- Use proven technology to reliably and economically produce electrical energy for a long period of time.
- Support greenhouse gas reduction goals of AB 32.
- Minimize environmental impacts and impacts to residential or commercial uses by locating in an area where there are few or no surrounding uses and limited potential to affect existing environment.

The IID Board has adopted the following policies and programs to address how to accommodate water demands under the terms of the QSA/ Transfers Agreements and minimize potential negative impacts on agricultural water uses:

⁶ [2019 Imperial County Crop and Livestock Report](#)

Imperial Integrated Regional Water Management Plan: adopted by the board on December 18, 2012, and by the County, the City of Imperial, to meet the basic requirement of California Department of Water Resources (CDWR) for an IRWM plan. In all, 14 local agencies adopted the 2012 Imperial IRWMP.

Interim Water Supply Policy for Non-Agricultural Projects: adopted by the board on September 29, 2009, to ensure sufficient water will be available for new development, in particular, anticipated renewable energy projects until the board selects and implements capital development projects such as those considered in the Imperial IRWMP.

Temporary Land Conversion Fallowing Policy: adopted by the board on May 8, 2012, and revised on March 29, 2016, to provide a framework for a temporary, long-term fallowing program to work in concert with the IWSP and IID's coordinated land use/water supply strategy.

Equitable Distribution Plan: adopted by the board on October 28, 2013, to provide a mechanism for IID to administer apportionment of the district's quantified annual supply of Colorado River water; the IID board approved a resolution repealing the Equitable Distribution Plan (EDP) on February 6, 2018.

In addition, water users within the IID service area are subject to the statewide requirement of reasonable and beneficial use of water under the California Constitution, Article X, section 2.

Imperial Integrated Regional Water Management Plan (October 2012)

The Imperial IRWMP serves as the governing document for regional water planning to meet present and future water resource needs and demands by addressing such issues as additional water supply options, demand management and determination and prioritization of uses and classes of service provided. In November 2012, the Imperial County Board of Supervisors approved the Imperial IRWMP, and the City of Imperial City Council and the IID Board of Directors approved it in December 2012. Approval by these three (3) stakeholders meets the basic requirement of California Department of Water Resources (CDWR) for an IRWMP. Through the IRWMP process, IID presented to the region stakeholders options in the event long-term water supply augmentation is needed, such as water storage and banking, recycling of municipal wastewater, and desalination of brackish water.⁷ As discussed herein, long term water supply augmentation is not anticipated to be necessary to meet proposed Project demands.

Chapter 5 of the 2012 Imperial IRWMP addresses water supplies (Colorado River and groundwater), demand, baseline and forecasted through 2050; and IID water budget. Chapter 12 addresses projects, programs and policies, and funding alternatives. Chapter 12 of the IRWMP lists, and Appendix N details, a set of capital projects that IID might pursue, including the amount of water that might result (AFY) and cost (\$/AF) if necessary. These also highlight potential capital improvement projects that could be implemented in the future.

⁷ October 2012 [Imperial Integrated Regional Water Management Plan](#), Chapter 12.

Imperial Valley historic 2015 and forecasted future for 2020 to 2055 non-agricultural water demand, are provided in **Table 5** in five-year increments. Total water demand for non-agricultural uses is projected to be 201.4 KAF in the year 2055. This is a forecasted increase in the use of non-agricultural water from 107.4 KAF for the period of 2015 to 2055.⁸ These values were modified from Chapter 5 of the Imperial IRWMP to reflect updated conditions from the IID Provisional Water Balance for calendar year 2015. Due to the recession in 2009 and other factors, non-agricultural growth projections have lessened since the 2012 Imperial IRWMP. Projections in **Table 5** have been adjusted (reduced by 3%) to reflect IID 2015 delivery data.

Table 5. Non-Agricultural Water Demand within IID Water Service Area, 2015-2055 (KAFY)

	2015	2020	2025	2030	2035	2040	2045	2050	2055
Municipal	30.0	30.9	36.8	39.8	41.5	46.3	51.7	57.8	61.9
Industrial	26.4	26.0	39.8	46.5	53.2	59.9	66.6	73.3	80.0
Other	5.5	6.5	5.5	5.5	5.5	5.5	5.5	5.5	5.5
Feedlots/Dairies	17.8	19.0	20.0	20.0	20.0	20.0	20.0	20.0	20.0
Envr Resources	8.3	9.2	12.0	12.0	12.0	12.0	12.0	12.0	12.0
Recreation	7.4	9.5	10.0	10.0	10.0	10.0	10.0	10.0	10.0
Service Pipes	12.0	12.0	12.0	12.0	12.0	12.0	12.0	12.0	12.0
Total Non Ag	107.4	113.1	136.1	145.8	154.2	165.7	177.8	190.6	201.4

Notes: 2015 non-agricultural water demands are from IID 2015 Provisional Water Balance rerun 03/28/2019 2020-2055 demands are modified from 2012 Imperial IRWMP Chapter 5, Table 5-22 p 5-50 based on IID 2015 Provisional Water Balance. Industrial Demand includes geothermal, but not solar, energy production. Next Update 2021

Agricultural evapotranspiration (ET) demand of approximately 1,476.4 KAF in 2015, decreased in 2020 to around 1,442.2 KAF. The termination of fallowing programs provided 103.5 KAF of water for Salton Sea mitigation in 2017. Forecasted agricultural ET remains constant, as reductions in water use are to come from efficiency conservation not reduction in agricultural production. Market forces and other factors may impact forecasted future water demand.

Table 6 provides the 2015 and 2020 historic and 2025-2055 forecasted agricultural consumptive use and delivery demand within the IID water service area. When accounting for agriculture ET, tailwater and tilewater, total agricultural consumptive use (CU) demand ranges from 2,157.9 KAF in 2015 to 2,208.5 KAF in 2055. Forecasted total agricultural delivery demand is around 1 KAFY higher than the CU demand, ranging from 2,158.9 KAF in 2015 to 2,209.5 KAF in 2055.

⁸ Wistaria Solar Ranch, Final Environmental Impact Report, December 2014

Table 6. Historic and forecasted Agricultural Water Consumptive Use and Delivery Demand within IID Water Service Area, 2015-2055 (KAFY)

	2015	2020	2025	2030	2035	2040	2045	2050	2055
Ag ET from Delivered & Stored Soil Water	1,475.4	1,442.2	1,567.5	1,567.5	1,567.5	1,567.5	1,567.5	1,567.5	1,567.5
Ag Tailwater to Salton Sea	282.9	312.9	268.0	218.0	218.0	218.0	218.0	218.0	218.0
Ag Tilewater to Salton Sea	398.6	410.2	423.0	423.0	423.0	423.0	423.0	423.0	423.0
Total Ag CU Demand	2,157.9	2,165.4	2,258.5	2,208.5	2,208.5	2,208.5	2,208.5	2,208.5	2,208.5
<i>Subsurface Flow to Salton Sea</i>	<i>1.0</i>	<i>1.0</i>	<i>1.0</i>	<i>1.0</i>	<i>1.0</i>	<i>1.0</i>	<i>1.0</i>	<i>1.0</i>	<i>1.0</i>
Total Ag Delivery Demand	2,158.9	2,166.4	2,259.5	2,209.5	2,209.5	2,209.5	2,209.5	2,209.5	2,209.5

Notes: 2015 record from IID 2015 Provisional Water Balance rerun 06/28/2019; 2020-2055 forecasts from spreadsheet used to develop Figure 19, et seq. in Imperial IRWMP Chapter 5 (Data provided by IID staff). Next Update 2026

In addition to agricultural and non-agricultural water demands, system operation demand must be included to account for operational discharge, main and lateral canal seepage; and for AAC seepage, river evaporation and phreatophyte ET from Imperial Dam to IID’s measurement site at AAC Mesa Lateral 5. These system operation demands are shown in Table 7. IID measures system operational uses and at All-American Canal Station 2900 just upstream of Mesa Lateral 5 Heading. Total system operational use for 2020 was 167 KAF, including 10 KAF of LCWSP input, 39.8 KAF of seepage interception input, and 40 KAF of unaccounted canal water input.

Table 7. IID System Operations Consumptive Use within IID Water Service Area and from AAC at Mesa Lateral 5 to Imperial Dam, (KAF), 2020

Delivery System Evaporation	24.4
Canal Seepage	90.8
Canal Spill	10.1
Lateral Spill	121.5
Seepage Interception	-39.0
Unaccounted Canal Water	-40.0
Total System Operational Use, In valley	167.8
Imperial Dam to AAC @ Mesa Lat 5 (<i>Dam-Mesa Lat 5</i>)	9.2
LCWSP	-10
Total System Operational Use in 2020	167.0

Source: 2020 Water Balance rerun 01/25/2021

IID Interim Water Supply Policy for Non-Agricultural Projects (September 2009)

The IID IWSP provides a mechanism to address water supply requests for projects being developed within the IID service area. The IWSP designates up to 25,000 AFY of IID’s annual Colorado River water supply for new non-agricultural projects, provides a mechanism and process to develop a water supply agreement for any appropriately permitted project, and establishes a framework and set of fees to

ensure the supplies used to meet new demands do not adversely affect existing users by funding water conservation or augmentation projects as needed.⁹

Depending on the nature, complexity and water demands of the proposed project, new projects may be charged a one-time Reservation Fee and an annual Water Supply Development Fee for the contracted water volume used solely to assist in funding new water supply projects. The applicability of the fee to certain projects will be determined by IID on a case-by-case basis, depending on the proportion of types of land uses and water demand proposed for a project. The 2021 fee schedule is shown in Table 8.

Table 8. Interim Water Supply Policy 2021 Annual Non-Agricultural Water Supply Development Fee Schedule

Annual Demand (AF)	Reservation Fee (\$/AF)*	Development Fee (\$/AF)*
0-500	\$75.40	\$301.59
501-1000	\$106.16	\$424.64
1001-2500	\$133.30	\$533.22
2501-5000	\$164.67	\$658.68

Adjusted annually in accordance with the Consumer Price Index (CPI).

IID customers with new projects receiving water under the IWSP will be charged the appropriate water rate based on measured deliveries, see [IID Water Rate Schedules](#). As of January 2021, IID has issued one Water Supply Agreement for 1,200 AFY, leaving a balance of 23,800 AFY of supply available for contracting under the IWSP.

IID Temporary Land Conversion Following Policy (May 2012)

Imperial County planning officials determined that renewable energy facilities were consistent with the county’s agricultural zoning designation and began issuing CUPs for these projects with ten- to twenty-year terms. These longer-term, but temporary, land use designations were not conducive to a coordinated land use/water supply policy as envisioned in the Imperial IRWMP, because temporary water supply assignments during a conditional use permit (CUP) term were not sufficient to meet the water supply verification requirements for new project approvals. Agricultural land owners also sought long-term assurances from IID that, at project termination, irrigation service would be available for them to resume their farming operations.

Based on these conditions, IID determined it had to develop a water supply policy that conformed to the local land use decision-making in order to facilitate new development and economic diversity in Imperial County which has resulted in the IID Temporary Land Conversion Following Policy (TLCFP).¹⁰ IID concluded that certain lower water use projects could still provide benefits to local water users. The resulting benefits; however, may not be to the same categories of use (e.g., MCI) but to the district as a whole.

⁹ IID website: [Municipal, Industrial and Commercial Customers](#).

¹⁰ IID website: [Temporary Land Conversion Following Policy \(TLCFP\)](#), and [The TLCFP](#) are the sources of the text for this section.

At the general manager's direction, staff developed a framework for a fallowing program that could be used to supplement the IWSP and meet the multiple policy objectives envisioned for the coordinated land use/water supply strategy. Certain private projects that, if implemented, will temporarily remove land from agricultural production within the district's water service area include renewable solar energy and other non-agricultural projects. Such projects may need a short-term water supply for construction and decommissioning activities and longer-term water service for facility operation and maintenance or for treating to potable water standards. Conserved water will be credited to the extent that water use for the project is less than historic water use for the project site's footprint as determined by the ten year water use history.¹¹

Water demands for certain non-agricultural projects are typically less than that required for agricultural production; this reduced demand allows water to be made available for other users under IID's annual consumptive use cap. This allows the district to avail itself of the ability during the term of the QSA/Transfer Agreements under [CWC Section 1013](#) to create conserved water through projects such as temporary land fallowing conservation measures. This conserved water can then be used to satisfy the district's conserved water transfer obligation and for environmental mitigation purposes.

Under the terms of the legislation adopted to facilitate the QSA/Transfer Agreements and enacted in [CWC Section 1013](#), the [TLCFP](#) was adopted by the IID board on May 8, 2012 and revised on March 29, 2016 to update the fee schedule for 2016. This policy provides a framework for a temporary, long-term fallowing program to work in concert with the IWSP. While conserved water generated from the TLCFP is limited by law for use for water transfer or environmental purposes, by satisfying multiple district objectives the TLCFP serves to reduce efficiency conservation and water use reduction demands on IID water users, thus providing district wide benefits.

IMPERIAL IRRIGATION DISTRICT'S WATER RIGHTS

The laws and regulations that influence IID's water supply are noted in this section. The Law of the River (as described below), along with the 2003 Quantification Settlement Agreement and Related Agreements serve as the laws, regulations and agreements that primarily influence the findings of this WSA. These agreements grant California the most senior water rights along the Colorado River and IID specify that IID has access to 3.1 MAF per year. These two components will influence future decisions in terms of water supply during periods of shortages.

California Law

IID's has a longstanding right to divert Colorado River water, and IID holds legal titles to all of its water and water rights in trust for landowners within the district (CWC §20529 and §22437; *Bryant v. Yellen*,

¹¹ For details of how water conservation yield attributable to land removed from agricultural production and temporarily fallowed is computed, see [TLCFP for Water Conservation Yield](#).

447 U.S. 352, 371 (1980), fn.23.). Beginning in 1885, a number of individuals, as well as the California Development Company, made a series of appropriations of Colorado River water under California law for use in the Imperial Valley. The rights to these appropriations were among the properties acquired by IID from the California Development Company.

Law of the River

Colorado River water rights are governed by numerous compacts, state and federal laws, court decisions and decrees, contracts, and regulatory guidelines collectively known as the “Law of the River.” Together, these documents form the basis for allocation of the water, regulation of land use, and management of the Colorado River water supply among the seven basin states and Mexico.

Of all regulatory literature that governs Colorado River water rights, the following are the specifics that impact IID:

- Colorado River Compact (1922)
- Boulder Canyon Project Act (1928)
- California Seven-Party Agreement (1931)
- Arizona v. California US Supreme Court Decision (1964, 1979)
- Colorado River Basin Project Act (1968)
- Quantification Settlement Agreement and Related Agreements (2003)
- 2003 Colorado River Water Delivery Agreement: Federal QSA for purposes of Section 5(b) Interim Surplus Guidelines (CRWDA)
- 1970 Criteria for Coordinated Long-Range Operation of Colorado River Reservoirs
- Annual Operating Plan (AOP) for Colorado River Reservoirs
- 2007 Colorado River Interim Guidelines for Lower Basin Shortages and Coordinated Operations for Lakes Powell and Mead (2007 Interim Guidelines)

Colorado River Compact (1922)

With authorization of their legislatures and urging of the federal government, representatives from the seven Colorado River basin states began negotiations regarding distribution of water from the Colorado River in 1921. In November 1922, an interstate agreement called the “Colorado River Compact” was signed by the representatives giving the Lower Basin perpetual rights to annual apportionments of 7.5 million acre-feet (MAF) of Colorado River water (75 MAF over ten years). The Upper Basin was to receive the remainder, which based on the available hydrological record was also expected to be 7.5 MAF annually, with enough left over to provide 1.5 MAF annually to Mexico.

Boulder Canyon Project Act (1928)

Provisions in the 1928 Boulder Canyon Project Act made the compact effective and authorized construction of Hoover Dam and the All-American Canal, and served as the United States’ consent to accept the Compact. Through a Presidential Proclamation on June 25, 1929, this act resulted in

ratification of the Compact by six of the basin states and required California to limit its annual consumptive use to 4.4 MAF of the lower basin's apportionment plus not less than half of any excess or surplus water unapportioned by the Compact. A lawsuit was filed by the State of Arizona after its refusal to sign. Through the implementation of its 1929 Limitation Act, California abided by this federal mandate. The Boulder Canyon Act authorized the Secretary of the Interior (Secretary) to "contract for the storage of water... and for the delivery thereof... for irrigation and domestic uses," and additionally defined the lower basin's 7.5 MAF apportionment split, with an annual allocation 0.3 MAF to Nevada, 2.8 MAF to Arizona, and 4.4 MAF to California. Even though the three states never formally settled or agreed to these terms, a 1964 Supreme Court decision (*Arizona v. California*, 373 U.S. 546) declared the three states' consent to be insignificant since the Boulder Canyon Project Act was authorized by the Secretary.

California Seven-Party-Agreement (1931)

Following implementation of the Boulder Canyon Project Act, the Secretary requested that California make recommendations regarding distribution of its apportionment of Colorado River water. In August 1931, under chairmanship of the State Engineer, the California Seven-Party Agreement was developed and authorized by the affected parties to prioritize California water rights. The Secretary accepted this agreement and established these priorities through General Regulations issued in September of 1931. The first four (4) priority allocations account for California's annual apportionment of 4.4 MAF, with agricultural entities using 3.85 MAF of that total. Additional priorities are defined for years in which the Secretary declares that excess waters are available.

Arizona v. California U.S. Supreme Court Decision (1964, 1979)

The 1964 Supreme Court decision settled a 25-year disagreement between Arizona and California that stemmed from Arizona's desire to build the Central Arizona Project to enable use of its full apportionment. California's argument was that as Arizona used water from the Gila River, which is a Colorado River tributary, it was using a portion of its annual Colorado River apportionment. An additional argument from California was that it had developed a historical use of some of Arizona's apportionment, which, under the doctrine of prior appropriation, precluded Arizona from developing the project. California's arguments were rejected by the U.S. Supreme Court. Under direction of the Supreme Court, the Secretary was restricted from delivering water outside of the framework of apportionments defined by law. Preparation of annual reports documenting consumptive use of water in the three lower basin states was also mandated by the Supreme Court. In 1979, present perfected water rights (PPRs) referred to in the Colorado River Compact and in the Boulder Canyon Project Act were addressed by the Supreme Court in the form of a Supplemental Decree.

In March of 2006, a Consolidated Decree was issued by the Supreme Court to provide a single reference to the conditions of the original 1964 decrees and several additional decrees in 1966, 1979, 1984 and 2000 that stemmed from the original ruling. The Consolidated Decree also reflects the settlements of the federal reserved water rights claim for the Fort Yuma Indian Reservation.

Colorado River Basin Project Act (1968)

In 1968, various water development projects in both the upper and lower basins, including the Central Arizona Project (CAP) were authorized by Congress. Under the Colorado River Basin Project Act, priority was given to California's apportionment over (before) the CAP water supply in times of shortage. Also under the act, the Secretary was directed to prepare long-range criteria for the Colorado River reservoir system in consultation with the Colorado River Basin States.

Quantification Settlement Agreement and Related Agreements (2003)

With completion of a large portion of the CAP infrastructure in 1994, creation of the Arizona Water Banking Authority in 1995, and the growth of Las Vegas in the 1990s, California encountered increasing pressure to live within its rights under the Law of the River. After years of negotiating among Colorado River Compact States and affected California water delivery agencies, a Quantification Settlement Agreement and Related Agreements and documents were signed on October 10, 2003, by the Secretary of Interior, IID, Coachella Valley Water District (CVWD), Metropolitan Water District of Southern California (MWD), San Diego County Water Authority (SDCWA), and other affected parties.

The Quantification Settlement Agreement and Related Agreements (QSA/Transfer Agreements) are a set of interrelated contracts that resolve certain disputes among the United States, the State of California, IID, MWD, CVWD and SDCWA, for a period of 35 to 75 years, regarding the reasonable and beneficial use of Colorado River water; the ability to conserve, transfer and acquire conserved Colorado River water; the quantification and priority of Priorities 3(a) and 6(a)¹² within California for use of Colorado River water; and the obligation to implement and fund environmental impact mitigation.

Conserved water transfer agreements between IID and SDCWA, IID and CVWD, and IID and MWD are all part of the QSA/Transfer Agreements. For IID, these contracts identify conserved water volumes and establish transfer schedules along with price and payment terms. As specified in the agreements, IID will transfer nearly 415,000 AF annually over a 35-year period (or longer), as follows:

- to MWD 110,000 AF [modified to 105,000 AF in 2007],
- to SDCWA 200,000 AF,
- to CVWD and MWD combined 103,000 AF, and
- to certain San Luis Rey Indian Tribes 11,500 AFY of water.

All of the conserved water will ultimately come from IID system and on-farm efficiency conservation improvements. In the interim, IID has implemented a Fallowing Program to generate water associated with Salton Sea mitigation related to the impacts of the IID/SDCWA water transfer, as required by the State Water Resources Control Board, which is to run from 2003 through 2017. In return for its QSA/Transfer Agreements programs and deliveries, IID will receive payments totaling billions of dollars

¹² Priorities 1, 2, 3(b), 6(b), and 7 of current Section 5 Contracts for the delivery of Colorado River water in the State of California and Indian and miscellaneous Present Perfected Rights within the State of California and other existing surplus water contracts are not affected by the QSA Agreement.

to fund needed efficiency conservation measures and to pay growers for conserved on-farm water, so IID can transfer nearly 14.5 MAF of water without impacting local productivity. In addition, IID will transfer to SDCWA 67,700 AFY annually of water conserved from the lining of the AAC in exchange for payment of lining project costs and a grant to IID of certain rights to use the conserved water. In addition to the 105,000 acre-feet of water currently being conserved under the 1988 IID/MWD Conservation Program, these more recent agreements define an additional 303,000 AFY to be conserved by IID from on-farm and distribution system conservation projects for transferred to SDCWA, CVWD, and MWD.

Colorado River Water Delivery Agreement (2003)¹³

As part of QSA/Transfer Agreements among California and federal agencies, the Colorado River Water Delivery Agreement: Federal QSA for purposes of Section 5(b) Interim Surplus Guidelines (CRWDA) was entered into by the Secretary of the Interior, IID, CVWD, MWD and SDCWA. This agreement involves the federal government because of the change in place of diversion from Imperial Dam into the All-American Canal to Parker Dam into MWD's Colorado River Aqueduct.

The CRWDA assists California to meet its "4.4 Plan" goals by quantifying deliveries for a specific number of years for certain Colorado River entitlements so transfers may occur. In particular, for the term of the CRWDA, quantification of Priority 3(a) was effected through caps on water deliveries to IID (consumptive use of 3.1 MAF per year) and CVWD (consumptive use of 330 KAF per year). In addition, California's Priority 3(a) apportionment between IID and CVWD, with provisions for transfer of supplies involving IID, CVWD, MWD and SDCWA are quantified in the CRWDA for a period of 35 years or 45 years (assumes SDCWA does not terminate in year 35) or 75 years (assumes SDCWA and IID mutually consent to renewal term of 30 years).

Allocations for consumptive use of Colorado River water by IID, CVWD and MWD that will enable California to stay within its basic annual apportionment (4.4 MAF plus not less than half of any declared surplus) are defined by the terms of the QSA/Transfer Agreements (Table 9). As specified in the QSA/Transfer Agreements, by 2026, IID annual use within (Imperial Valley) is to be reduced to just over 2.6 MAF of its 3.1 MAF quantified annual apportionment. The remaining nearly 500,000 AF (which includes the 67,000 AF from AAC lining) are to be transferred annually to urban water users outside of the Imperial Valley.

¹³ *CRWDA: Federal QSA accessed 7 June 2017.*

Table 9. CRWDA Annual 4.4 MAF Apportionment (Priorities 1 to 4) for California Agencies (AFY)

User	Apportionment (AFY)
Palo Verde Irrigation District and Yuma Project*	420,000
Imperial Irrigation District	3,100,000
Coachella Valley Water District	330,000
Metropolitan Water District of Southern California*	550,000
Total:	4,400,000

* PVID and Yuma Project did not agree to a cap; value represents a contractual obligation by MWD to assume responsibility for any overages or be credited with any volume below this value.

Notes: All values are consumptive use at point of Colorado River diversion: Palo Verde Diversion Dam (PVID), Imperial Dam (IID and CVWD), and Parker Dam (MWD). Source: IID Annual Water Report

Quantification of Priority 6(a) was effected through quantifying annual consumptive use amounts to be made available in order of priority to MWD (38 KAF), IID (63 KAF), and CVWD (119 KAF) with the provision that any additional water available to Priority 6(a) be delivered under IID's and CVWD's existing water delivery contract with the Secretary¹⁴. The CRWDA provides that the underlying water delivery contract with the Secretary remain in full force and effect. (*Colorado River Documents 2008*, Chapter 6, pages 6-12 and 6-13). The CRWDA also provides a source of water to effect a San Luis Rey Indian Water rights settlement. Additionally, the CRWDA satisfies the requirement of the 2001 Interim Surplus Guidelines (ISG) that a QSA be adopted as a prerequisite to the interim surplus determination by the Secretary in the ISG.

Inadvertent Overrun Payback Policy (2003)

The CRWDA Inadvertent Overrun Payback Policy (IOPP), adopted by the Secretary contemporaneously with the execution of the CRWDA, provides additional flexibility to Colorado River management and applies to entitlement holders in the Lower Division States (Arizona, California and Nevada)¹⁵. The IOPP defines inadvertent overruns as "Colorado River water diverted, pumped, or received by an entitlement holder of the Lower Division States that is in excess of the water users' entitlement for the year." An entitlement holder is allowed a maximum overrun of 10 percent (10%) of its Colorado River water entitlement.

In the event of an overrun, the IOPP provides a mechanism to payback the overrun. When the Secretary has declared a normal year for Colorado River diversions, a contractor has from one to three years to pay back its obligation, with a minimum annual payback equal to 20 percent of the entitlement holder's maximum allowable cumulative overrun account or 33.3 percent of the total account balance, whichever is greater. However, when Lake Mead is below 1125 feet on January 1, the terms of the IOPP require that the payment of the inadvertent overrun obligation be made in the calendar year after the overrun is reported in the USBR Lower Colorado Region Colorado River Accounting and Water Use Report [for] Arizona, California, and Nevada (Decree Accounting Report).¹⁶

¹⁴ When water levels in the Colorado River reservoirs are low, Priority 5, 6 and 7 apportionments are not available for diversion.

¹⁵ USBR, 2003 CRWDA ROD Implementation Agreement, IOPP and Related Federal Actions Final EIS. Section IX. Implementing the Decision A. Inadvertent Overrun and Payback Policy. Pages 16-19 of 34.

¹⁶ 2003 CRWDA ROD. Section IX. A.6.c., page 18 of 34.

1970 Criteria for Coordinated Long-Range Operation of Colorado River Reservoirs

The 1970 Operating Criteria control operation of the Colorado River reservoirs in compliance with requirements set forth in the Colorado River Compact of 1922, the United States-Mexico Water Treaty of 1944, the Colorado River Storage Project Act of 1956, the Boulder Canyon Projects Act (Lake Mead) and the Colorado River Basin Project Act (Upper Basin Reservoirs) of 1968, and other applicable federal laws. Under these Operating Criteria, the Secretary makes annual determinations published in the USBR Annual Operating Plan for Colorado River Reservoirs (discussed below) regarding the release of Colorado River water for deliveries to the lower basin states. A requirement to equalize active storage between Lake Powell and Lake Mead when there is sufficient storage in the Upper Basin is included in these operating criteria. Figure 5 identifies the major storage facilities at the upper and lower basin boundaries.

Annual Operating Plan for Colorado River Reservoirs (Applicable Only if Lake Mead Surplus/Shortage)

The AOP is developed in accordance with Section 602 of the Colorado River Basin Project Act (Public Law 90-537); the Criteria for Coordinated Long-Range Operations of Colorado River Reservoirs Pursuant to the Colorado River Basin Project Act of 1968, as amended, promulgated by the Secretary of the Interior; and Section 1804(c)(3) of the Grand Canyon Protection Act (Public Law 102-575). As part of the AOP process, the Secretary makes determinations regarding the availability of Colorado River water for deliveries to the lower basin states, including whether normal, surplus, and shortage conditions are in effect on the lower portion of the Colorado River.

2007 Colorado River Interim Guidelines for Lower Basin Shortages (2007 Interim Guidelines)

A multi-year drought in the Colorado River Upper Basin triggered the need for the 2007 Interim Shortage Guidelines. In the summer of 1999, Lake Powell was essentially full of reservoir storage at 97 percent of capacity. However, precipitation fell off starting in October 1999 and 2002 inflow was the lowest recorded since Lake Powell began filling in 1963.¹⁷ By August 2011, inflow was 279 percent (279%) of average; however, drought resumed in 2012 and continued through calendar year 2020. Using the record in Table 10, average unregulated inflow to Lake Powell for water years 2000-2020 is 75.47 percent (75.5%); or if 2011 is excluded, 72.45 percent (72.5%) of the historic average.

Table 10. Unregulated Inflow to Lake Powell, Percent of Historic Average, 2000-2019

2000	2001	2002	2003	2004	2005	2006	2007	2008	2009	2010
62%	59%	25%	51%	49%	105%	73%	68%	102%	88%	73%
2011	2012	2013	2014	2015	2016	2017	2018	2019	2020	
136%	35%	49%	90%	83%	80%	100%	36%	110%	110%	

Source: [UCR Water Operations: Historic Data](#) (2000-2020)

¹⁷ Water Year: October 1 through September 30 of following year, so water year ending September 30, 1999

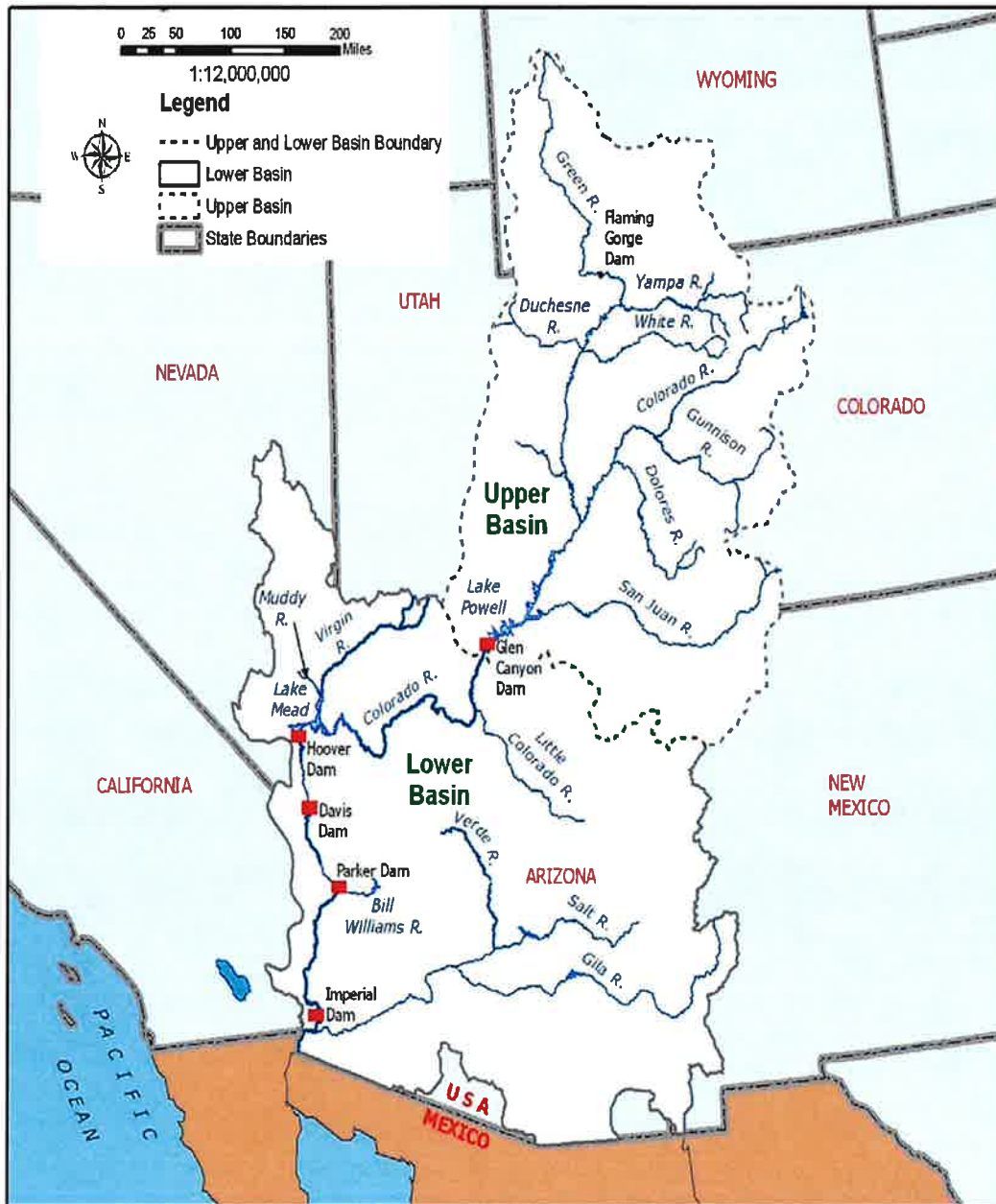


Figure 5. Major Colorado River Reservoir Storage Facilities and Basin Location Map

Source: Final EIS – Colorado River Interim Guidelines for Lower Basin Shortages and Coordinated Operations for Lake Powell and Lake Mead, Volume 1 Chapter 1 Purpose and Need , p I-10.

In the midst of the drought period, USBR developed 2007 Interim Guidelines with consensus from the seven basin states, which selected the Draft EIS Preferred Alternative as the basis for USBR's final

determination. The basin states found the Preferred Alternative best met all aspects of the purpose and need for the federal action.¹⁸

The 2007 Interim Guidelines Preferred Alternative highlights the following:

1. The need for the Interim Guidelines to remain in place for an extended period of time.
2. The desirability of the Preferred Alternative based on the facilitated consensus recommendation from the basin states.
3. The likely durability of the mechanisms adopted in the Preferred Alternative in light of the extraordinary efforts that the basin states and water users have undertaken to develop implementing agreements that will facilitate the water management tools (shortage sharing, forbearance, and conservation efforts) identified in the Preferred Alternative
4. That the range of elements in the Preferred Alternative will enhance the Secretary's ability to manage the Colorado River reservoirs in a manner that recognizes the inherent tradeoffs between water delivery and water storage.

In June 2007, USBR announced that a preferred alternative for Colorado River Interim Guidelines for Lower Basin Shortages and Coordinated Operations of Lake Powell and Lake Mead (Final Preferred Alternative) had been determined. The Final Preferred Alternative, based on the basin states' consensus alternative and an alternative submitted by the environmental interests called "Conservation Before Shortage," is comprised of four key operational elements which are to guide operations of Lake Powell and Lake Mead through 2026 are:

1. Shortage strategy for Lake Mead and Lower Division states: The Preferred Alternative proposed discrete levels of shortage volumes associated with Lake Mead elevations to conserve reservoir storage and provide water users and managers in the Lower Basin with greater certainty to know when, and by how much, water deliveries will be reduced during low reservoir conditions.
2. Coordinated operations of Lake Powell and Lake Mead: The Preferred Alternative proposed a fully coordinated operation of the reservoirs to minimize shortages in the Lower Basin and to avoid risk of curtailments of water use in the Upper Basin.
3. Mechanism for storage and delivery of conserved water in Lake Mead: The Preferred Alternative proposed the Intentionally Created Surplus (ICS) mechanism to provide for the creation, accounting, and delivery of conserved system and non-system water thereby promoting water conservation in the Lower Basin. Credits for Colorado River or non-Colorado River water that has been conserved by users in the Lower Basin creating an ICS would be made available for release from Lake Mead at a later time. The total amount of credits would be 2.1 MAF, but this amount could be increased up to 4.2 MAF in future years.

¹⁸ USBR *Colorado River Interim Guidelines for Lower Basin Shortages and Coordinated Operations for Lake Powell and Lake Mead* <<http://www.usbr.gov/lc/region/programs/strategies.html>>

4. **Modifying and extending elements of the Interim Surplus Guidelines (ISG).** The ISG determines conditions under which surplus water is made available for use within the Lower Division states. These modifications eliminate the most liberal surplus conditions thereby leaving more water in storage to reduce the severity of future shortages.

With respect to the various interests, positions and views of the seven basin states, this provision adds an important element to the evolution of the legal framework for prudent management of the Colorado River. Furthermore, the coordinated operation element allows for adjustment of Lake Powell releases to respond to low reservoir storage conditions in either Lake Powell or Lake Mead.¹⁹ States found the Preferred Alternative best met all aspects of the purpose and need for the federal action.²⁰ The 2007 Interim Guidelines are in place from 2008 through December 31, 2025 (through preparation of the 2026 Annual Operating Plan).

Lower Colorado Region Water Shortage Operations

The drought in the Colorado River watershed has continued through 2020 despite an increase in observed runoff in August 2011 when unregulated inflow to Lake Powell was 279 percent of the average. Since 2000, Lake Mead has been below the “average” level of lake elevations (see **Figure 6**). Such conditions have caused the preparation of shortage plans for waters users in Arizona and Nevada, and in Mexico.

¹⁹ For a discussion of the 2007 Interim Guidelines, see: [Intermountain West Climate Summary](#) by The Western Water Assessment, issued Jan. 21, 2008, Vol. 5, Issue 1, January 2009 Climate Summary, Feature Article, pages 5-7, 22 Mar 2013.

²⁰ [USBR Colorado River Interim Guidelines for Lower Basin Shortages and Coordinated Operations for Lake Powell and Lake Mead.](#)

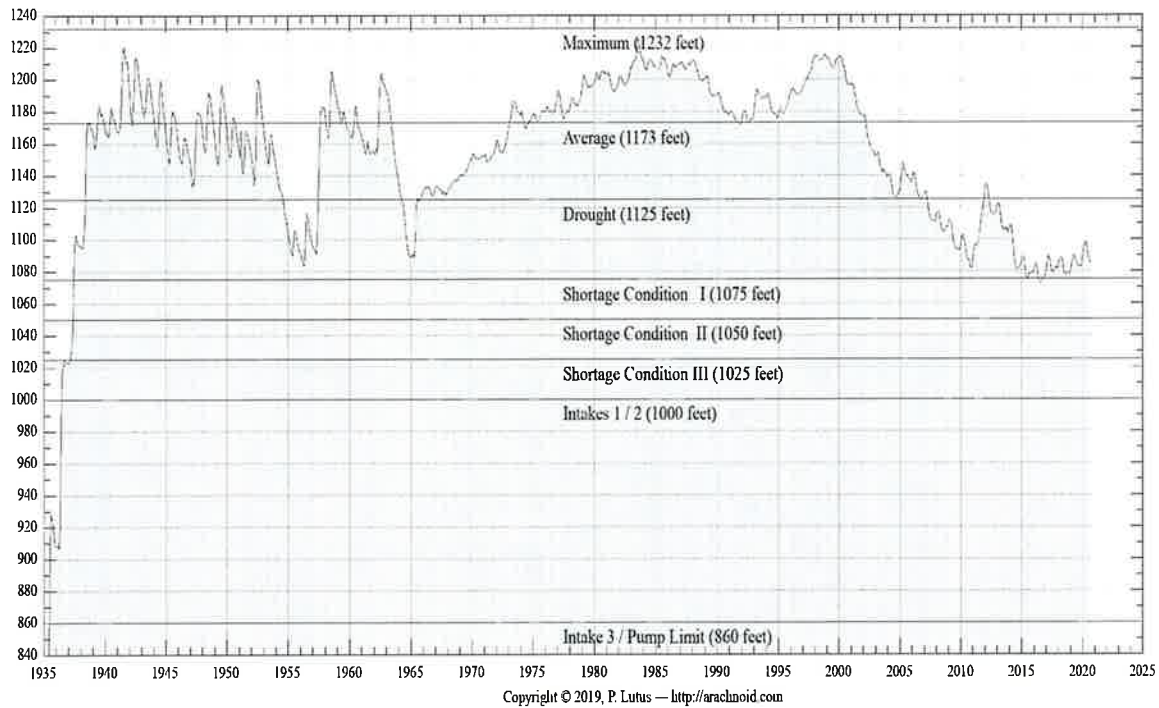


Figure 6. Lake Mead Water Elevation Levels 2020 visit <<http://www.arachnoid.com/NaturalResources/index.html>>

According to guidelines put in place in 2007, Arizona and Nevada begin to take shortages when the water elevation in Lake Mead falls below 1,075 feet. The volumes of shortages increase as water levels fall to 1,050 feet and again at 1,025 feet. In 2012, Mexico agreed to participate in a 5-year pilot agreement to share specific volumes of shortages at the same elevations. The 2007 interim shortage guidelines contain no reductions for California, which has senior water rights to the Central Arizona Project water supply, through 2025 when the guidelines expire. If Lake Mead's elevation drops to 1,025 feet, a re-consultation process would be triggered among the basin states to address next steps. Consultation would start out within each state, then move to the three lower basin states, followed by all seven states and the USBR. Mexico will then be brought into the process unless they choose to participate earlier.

IMPERIAL IRRIGATION DISTRICT WATER SUPPLY AND DEMAND

SB 610 requires an analysis of a normal, single dry, and multiple dry water years to show that adequate water is available for the proposed Project in various climate scenarios. Water availability for this Project in a normal year is no different from water availability during a single-dry and multiple-dry year scenarios. This is due to the small effect rainfall has on water availability in IID's arid environment along with IID's strong entitlements to the Colorado River water supply. Local rainfall does have some impact on how much water is consumed (i.e. if rain falls on agricultural lands, those lands will not demand as

much irrigation), but does not impact the definition of a normal year, a single-dry year or a multiple-dry year scenario.

Water Availability – Normal Year

IID is entitled to annual net consumptive use of 3.1 MAF of Colorado River, less its QSA/Transfer Agreement obligations. Imperial Dam, located north of Yuma, Arizona, serves as a diversion structure for water deliveries throughout southeastern California, Arizona and Mexico. Water is transported to the IID water service area through the AAC for use throughout the Imperial Valley. IID historic and forecast net consumptive use volumes at Imperial Dam from CRWDA Exhibit B are shown in Table 11. Volumes 2003-2020 are adjusted for USBR Decree Accounting historic records. Volumes for 2021-2077 are from CRWDA Exhibit B modified to reflect 2014 Letter Agreement changes to the 1988 IID/MWD Water Conservation Agreement.²¹

Table 11. IID Historic and Forecast Net Consumptive Use for Normal Year, Single-Dry Year and Multiple-Dry Year Water Supply, 2003-2037, et seq. (CRWDA Exhibit B)

IID Quantification and Transfers, Volumes in KAF at Imperial Dam ¹										
Col 1	2	3	4	5	6	7	8	9	10	11
Year	IID Priority 3(a)								IID Total Reduction (Σ Cols 3-9) ⁵	IID Net [Available for] Consumptive Use (Col 2 - 10)
	IID 3(a) Quantified Amount	IID Reductions								
		1988 MWD Transfer ²	SDCWA Transfer	AAC Lining	Salton Sea Mitigation SDCWA Transfer ³	Intra-Priority 3 CVWD Transfer	MWD Transfer w\ Salton Sea Restoration ⁴	Misc. PPRs		
2003	3,100	105.1	10.0	0.0	0.0	0.0	0.0	11.5	126.6	2978.2
2004	3,100	101.9	20.0	0.0	15.0	0.0	0.0	11.5	148.4	2743.9
2005	3,100	101.9	30.0	0.0	15.0	0.0	0.0	11.5	158.4	2756.8
2006	3,100	101.2	40.0	0.0	20.0	0.0	0.0	11.5	172.7	2909.7
2007	3,100	105.0	50.0	0.0	25.0	0.0	0.0	11.5	191.5	2872.8
2008	3,100	105.0	50.0	8.9	26.0	4.0	0.0	11.5	205.4	2825.1
2009	3,100	105.0	60.0	65.5	30.1	8.0	0.0	11.5	280.1	2566.7
2010	3,100	105.0	70.0	67.7	33.8	12.0	0.0	11.5	294.8	2540.5
2011	3,100	103.9	63.3	67.7	0.0	16.0	0.0	11.5	262.4	2915.8
2012	3,100	104.1	106.7	67.7	15.2	21.0	0.0	11.5	326.2	2,903.2
2013	3,100	105.0	100.0	67.7	71.4	26.0	0.0	11.5	381.6	2,554.9
2014	3,100	104.1	100.0	67.7	89.2	31.0	0.0	11.5	403.5	2,533.4
2015	3,100	107.82	100.0	67.7	153.3	36.0	0.0	11.5	476.3	2,480.9
2016	3,100	105.0	100.0	67.7	130.8	41.0	0.0	11.5	456.0	2,504.3
2017	3,100	105.0	100.0	67.7	105.3	45.0	0.0	9.9	434.5	2,548.2
2018	3,100	105	130	67.7	0.1	63	0.0	11.5	377.3	2,722.8
2019 ⁶	3,100	105	160	67.7	46.55	68	0.0	11.5	458.75	2,687.8

²¹ [2014 Imperial Irrigation District Letter Agreement](#) for Substitution and Conservation Modifications to the IID/MWD Water Conservation Agreement - December 17, 2014.

IID SB 610 WSA for VEGA SES 4 Solar Energy Storage Project

IID Quantification and Transfers, Volumes in KAF at Imperial Dam ¹										
Col 1	2	3	4	5	6	7	8	9	10	11
Year	IID Priority 3(a)									IID Net [Available for] Consumptive Use (Col 2 - 10)
	IID 3(a) Quantified Amount	IID Reductions								
		1988 MWD Transfer ²	SDCWA Transfer	AAC Lining	Salton Sea Mitigation SDCWA Transfer ³	Intra-Priority 3 CVWD Transfer	MWD Transfer w\ Salton Sea Restoration ⁴	Misc. PPRs	IID Total Reduction (Σ Cols 3-9) ⁵	
2020	3,100	105	192.5	67.7	0.0	73	0.0	9.8	448.0	2,652.0
2021	3,100	105	205	67.7	0	78	0.0	11.5	467.2	2,632.8
2022	3,100	105	203	67.7	0	83	0.0	11.5	470.2	2,629.8
2023	3,100	105	200	67.7	0	88	0.0	11.5	472.2	2,627.8
2024	3,100	105	200	67.7	0	93	0.0	11.5	477.2	2,622.8
2025	3,100	105	200	67.7	0	98	0.0	11.5	482.2	2,617.8
2026	3,100	105	200	67.7	0	103	0.0	11.5	487.2	2,612.8
2027	3,100	105	200	67.7	0	103	0.0	11.5	487.2	2,612.8
2028	3,100	105	200	67.7	0	103	0.0	11.5	487.2	2,612.8
2029-37	3,100	105	200	67.7	0	103	0.0	11.5	487.2	2,612.8
2038-47 ⁷	3,100	105	200	67.7	0	103	0.0	11.5	487.2	2,612.8
2048-77 ⁸	3,100	105	200	67.7	0	50	0.0	11.5	434.2	2,665.8

1. 2003 through 2020, volumes are adjusted for actual USBR Decree Accounting values; IID Total Reduction and Net Available for Consumptive Use may not equal Col 2 minus Col 10, if IID conservation/Use was not included in Exhibit B.
2. 2014 Letter of Agreement provides that, effective January 2016 total amount of conserved water available is 105 KAFY
3. Salton Sea Mitigation volumes may vary based on conservation volumes and method of conservation.
4. This transfer is not likely given lack of progress on Salton Sea restoration as of 2018; shaded entries represents volumes that may vary..
5. Reductions include conservation for 1988 IID/MWD Transfer, IID/SDCWA Transfer, AAC Lining; SDCWA Transfer Mitigation, MWD Transfer w/Salton Sea Restoration (if any); Misc. PPRs. Amounts are independent of increases and reductions as allowed by the IOPP.
6. In order to resolve the outstanding 2010 Salton Sea mitigation water pre-delivery issue, IID left 46,546 AF of extraordinary conservation in Lake Mead. See IID's December 19, 2019 revised 2019 water order and Reclamation's March 10, 2020 approval letter.
7. Assumes SDCWA does not elect termination in year 35.
8. Assumes SDCWA and IID mutually consent to renewal term of 30 years.
9. Modified from 100 KAFY in CRWDA Exhibit B; stating in 2018 MWD will provide CVWD 50 KAFY of the 100 KAFY.

Source: [CRWDA: Federal QSA](#) Exhibit B, p 13; updated values from [2019 QSA Implementation Report](#)

Due to limits on annual consumptive use of Colorado River water under the QSA/Transfer Agreements, IID’s water supply during a normal year is best represented by the CRWDA Exhibit B Net Available for Consumptive Use (Table 11 , Column 11). The annual volume is IID Priority 3(a) Quantified Amount of 3.1 million acre-feet (MAF) (Table 11 , Column 2) less the IID transfer program reductions for each year (Table 11, Columns 3-9). IID suggests Table 11, which assumes full use of IID’s quantified water supply, be used in determining base normal year water availability.

CRWDA Exhibit B Net Available for Consumptive Use volumes less system operation demand represents the amount of water available for delivery by IID Water Department to its customers each year. In a normal year, perhaps 50,000 to 100,000 AF of effective rainfall would fall in the IID water service area. However, rainfall is not evenly distributed throughout the IID water service area and is not taken into account by IID in the submittal of its Estimate of Diversion (annual water order) to the USBR.

Expected Water Availability – Single Dry and Multiple Dry Years

When drought conditions exist within the IID water service area, as has been the case for the past decade or so, the water supply available to meet agricultural and non-agricultural water demands remains the same as normal year water supply because IID continues to rely solely on its entitlement for Colorado River water. Due to the priority of IID water rights and other agreements, drought conditions affecting Colorado River water supplies cause shortages for Arizona, Nevada and Mexico, before impacting California and IID. Accordingly, the Net Available for Consumptive Use volumes in Table 11, Column 11 represents the water supply at Imperial Dam available for diversion by IID in single-dry year and multiple-dry year scenarios.

Under CRWDA Inadvertent Overrun Payback Policy (IOPP), IID has some flexibility to manage its water use. When the water level in Lake Mead is above 1,125 feet, an overrun of its USBR approved annual water order is permissible, and IID has up to three years to pay water use above the annual water order. When Lake Mead’s water level is at or below 1,125 feet on January 1 in the calendar year after the overrun is reported in the USBR Lower Colorado Region Decree Accounting Report, the IOPP prohibits additional overruns and requires that outstanding overruns be paid back in the subsequent calendar year rather than in three years as allowed under normal conditions; that is, the payback is to be made in the calendar year following publication of the overrun in the USBR Decree Accounting Report. For historic IID annual rainfall, net consumptive use, transfers and IID underrun/overrun amounts, see Table 12. For purposes of this WSA, years with a shortage condition that impacts non-agricultural projects such as an IOPP payback obligation constitute “dry” years for IID.

In years of inadvertent overrun payback, conditions such as those in Sections 3.7 and 3.8 of the 2012 IWSP Water Agreement may go into effect, with the result that less water would be available for non-agricultural development contractors. Under such conditions, IID has requested that Vega SES 4, LLC management work with IID to ensure it can manage the reduction. IID has further indicated that, provided a water supply agreement is approved and executed by IID under the provisions of the IWSP, IID will have sufficient water to support the water of this Project.

Table 12. IID Annual Rainfall (In), Net Consumptive Use and Underrun/Overrun Amounts (AF), 1988-2020

Year	IID Total Annual Rainfall	IID Water Users	IID/MWD Transfer	IID/ SDCWA Transfer	SDCWA Transfer Salton Sea Mitigation	IID Underrun /<Overrun>	IID/CVWD Transfer	AAC Lining
1988		2,947,581						
1989		3,009,451						
1990	91,104	3,054,188	6,110					
1991	192,671	2,898,963	26,700					
1992	375,955	2,575,659	33,929					
1993	288,081	2,772,148	54,830					
1994	137,226	3,048,076	72,870					
1995	159,189	3,070,582	74,570					

IID SB 610 WSA for VEGA SES 4 Solar Energy Storage Project

Year	IID Total Annual Rainfall	IID Water Users	IID/MWD Transfer	IID/ SDCWA Transfer	SDCWA Transfer Salton Sea Mitigation	IID Underrun /<Overrun>	IID/CVWD Transfer	AAC Lining
1996	78,507	3,159,609	90,880					
1997	64,407	3,158,486	97,740					
1998	100,092	3,101,548	107,160					
1999	67,854	3,088,980	108,500					
2000	29,642	3,112,770	109,460					
2001	12,850	3,089,911	106,880					
2002	12,850	3,152,984	104,940					
2003	116,232	2,978,223	105,130	10,000	0	<6,555>		
2004	199,358	2,743,909	101,900	20,000	15,000	-166,408		
2005	202,983	2,756,846	101,940	30,000	15,000	-159,881		
2006	19,893	2,909,680	101,160	40,000	20,000	<12,414>		
2007	64,580	2,872,754	105,000	50,000	25,021	<6,358>		
2008	63,124	2,825,116	105,000	50,000	26,085	-47,999	4,000	8,898
2009	30,0354	2,566,713	105,000	60,000	30,158	-237,767	8,000	65,577
2010	189,566	2,545,593	105,000	70,000	33,736	-207,925	12,000	67,700
2011	109,703	2,915,784	103,940	63,278	0	<82,662>	16,000	67,700
2012	133,526	2,903,216	104,140	106,722	15,182	<134,076>	21,000	67,700
2013	134,497	2,554,845	105,000	100,000	71,398	-64,981	26,000	67,700
2014	53,517	2,533,414	104,100	100,000	89,168	-797	31,000	67,700
2015	97,039	2,480,933	107,820	100,000	153,327	-90,025	36,000	67,700
2016	90,586	2,504,258	105,000	100,000	130,796	-62,497	41,000	67,700
2017	105,919	2,548,171	105,000	100,000	105,311	-30,591	45,000	67,700
2018	63,318	2,625,422	105,000	130,000	0	0	63,000	67,700
2019	146,384	2,558,136	105,000	160,000	46,555	-34,215	68,000	67,700
2020	129,693	2,493,661	105,000	192,500	0	-95,715	73,000	67,700

Notes: Volumes in acre-feet and except Total Annual Rainfall are USBR Decree Accounting Report record at Imperial Dam.

IID Total Annual Rainfall from IID Provisional Water Balance, first available calculations are for 1990

Not all IID QSA programs are shown on this table.

Source: USBR Decree Accounting reports, except IID Total Rainfall and IID Overrun/Underrun is a separate calculation

Source: 2019 IID QSA Implementation Report and 2020 IID SWRCB Report, page 31 of 335; IID Total Rainfall and IID Overrun/Underrun is a separate calculation

Equitable Distribution Plan (EDP)

A 2006 study by Hanemann and Brookes suggested that overrun conditions were likely to occur 40-50% of the years during the decade following the report. On November 28, 2006, the IID Board of Directors adopted Resolution No 22-2006 approving development and implementation of an Equitable Distribution Plan to deal with times when customers' demand would exceed IID's Colorado River supply. The EDP, adopted in 2007 allowed the IID Board to institute an apportionment program. As part

of this resolution, the IID Board directed the General Manager to prepare the rules and regulations necessary or appropriate to implement the plan within the district. The 2009 Regulations for EDP were created to enable IID to implement a water management tool (apportionment) to address years in which water demand is expected to exceed supply. So far, for the 17 years from 2003 through 2020, demand has exceeded supply by some amount for a total of five years (see Table 12). IID has not experienced any overruns since 2012.

The IID 2013 Revised EDP, adopted by the Board on October 28, 2013, further allowed IID to pay back its outstanding overruns using an EDP Apportionment, and it was expected that an annual EDP Apportionment would be established for each of the next several years, if not for the duration of the QSA/Transfer Agreements. For purposes of this WSA, years with a shortage condition that impacts non-agricultural projects such as an IOPP payback obligation constitute “dry” years for IID. For single-dry year and multiple-dry water year assessments, IID’s EDP shall govern. IOPP payback, EDP Apportionment, and the IWSP are further discussed under single-dry and multiple-dry year projections. However, the implementation of the EDP apportionment was legally challenged, and on February 6, 2018, the IID board approved a resolution repealing the EDP until the issue is resolved. As of the date of this WSA, a resolution had been reached, but a modified EDP has yet to be re-instated.

Water Management under Inadvertent Overrun Payback Policy (IOPP)

On January 1, 2013, the water level in Lake Mead was 1120.5 feet and for the first time since the IOPP came into effect, Lower Colorado River Basin water users faced a shortage condition (Figure 7). For IID, this meant that outstanding overruns must be paid back to the river in calendar years 2013 and 2014 as described below and shown in Table 13.

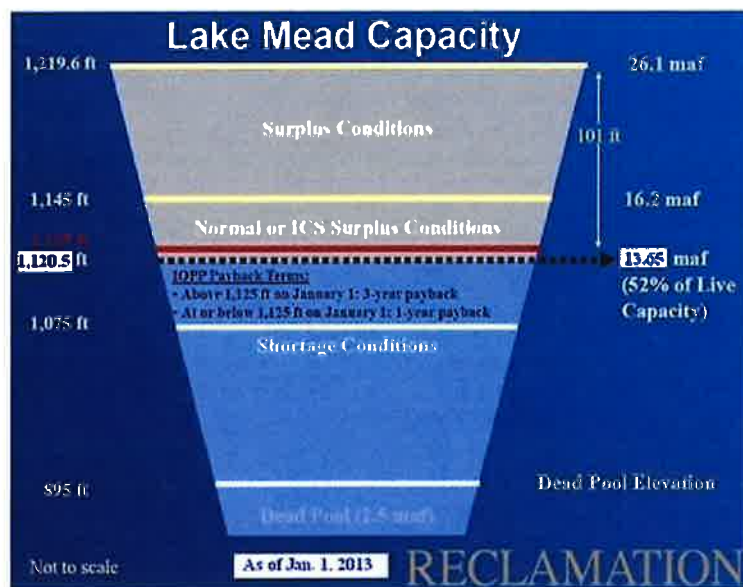


Figure 7. Lake Mead IOPP Schematic

IID’s maximum allowable cumulative overrun account is 62,000 AF.²² Thus, for IID’s 2011 overrun of 82,662 AF (which was published in 2012), 62,000 AF were to be paid back at the river in calendar year 2013, with the remaining 20,662 AF to be paid back in 2014; however, due to an early payback of 6,290 AF in 2012, IID had 55,710 AF to pay back in 2013 and 20,662 AF of the 2011 overrun to pay back in 2014. In addition, because of the low level of Lake Mead on Jan 1, 2013, IID’s entire 2012 overrun of 134,076 AF must be paid back in 2014, for a total of 154,738 AF in 2014. Furthermore, under the terms of the IOPP, no overruns are allowed in a year when payback is required. IID has not experienced any overrun pay back since 2014.

Table 13. IID Inadvertent Overrun Payback to the Colorado River under the IOPP, 2012-2020

Calendar Year of Payback	2011 Overrun Payback (AF)	2012 Overrun Payback (AF)	Payback Total for Calendar Year (AF)
2013	55,710	-	55,710
2014	20,662	134,076	154,738
Total Payback	76,372	134,076	210,448

Notes: All values are consumptive use volumes at Imperial Dam (AF).
 2013 Payback Total was 62 KAF, but in 2012 IID had 6,290 AF of early payback, reducing volume to 55,710 AF

The 2013 IOPP payback obligation and prohibition on overruns in payback years, led the IID Board to implement an apportionment program pursuant to the 2009 Regulations for EDP, which were subsequently revised and modified. The Revised 2013 EDP was a version approved and adopted by the IID Board on October 28, 2013 (see Attachment B). The Revised 2013 EDP also establishes an agriculture water clearinghouse to facilitate the movement of apportioned water between agricultural water users and between farm units. This is to allow growers and IID to balance water demands for different types of crops and soils with the apportionment s that are made. IID’s Water Conservation Committee agreed on a July 1, 2013 start date for the agricultural water clearinghouse

Generally, the EDP Apportionment is not expected to impact industrial use. However, given the possibility of continuing drought on the Colorado River and other stressors, provisions such as the 2012 IWSP Water Agreement sections 3.7 and 3.8 as well for dry and multiple dry year water assessment may come into effect. However, IID has agreed to work with Project proponents to ensure to the extent possible that the IWSP Water Agreement terms will not negatively impact Project operation.

Project Water Availability for a 20-Year Period to Meet Projected Demands

The proposed Project will obtain drinking water from a certified State of California provider. Approximately 275 AF of untreated canal water will be used during the 18-month construction period for dust control and soil conditioning. During operations, up to 10 AFY of untreated canal water will be used for washing of the solar PV modules, as needed. Bottled water will be provided for potable needs during construction. Water for employee sanitation will be provided by temporary, portable facilities (toilets and hand wash stations). There will be no potable water connection to the facility.

²² For IID Quantified Amount: 3.1 MAFY *10 percent = 310,000 AF allowable cumulative overrun account amount; minimum repayment in a calendar year is the less of 310,000 * 20 percent = 62,000 or the amount in the account, if less than 62,000 AF.

Untreated Colorado River water will be supplied to the project via the adjacent All American Canal under an IWSP Water Supply Agreement with IID. The Project site is currently open land and does not receive water from IID. Thus, the proposed Project water demand would be a new use within the District service area.

As noted previously, under the terms of California legislation adopted to facilitate the QSA/Transfer Agreements and enacted in [CWC Section 1013](#), the IID board adopted the [TLCFP](#) to address how to deal with any such temporary reduction of water use by projects like such as solar projects that are developed under a CUP.

While conserved water generated from the TLCFP is limited by law for use for water transfer or environmental purposes, by satisfying multiple district objectives the TLCFP serves to reduce the need for efficiency conservation and other water use reduction practices on the part of IID and its water users providing the district with wide benefits. One of the considerations in developing the TLCFP was to provide agricultural land owners with long-term assurances from IID that, at Project termination, irrigation service would be available for them to resume farming operations.

IWSP Water

At the present time, IID is providing water for use by solar energy generation projects under Water Rate [Schedule 7 General Industrial Use](#). If IID determines that the proposed Project should obtain water under IID's Interim Water Supply Policy (IWSP) for non-agricultural projects rather than [Schedule 7 General Industrial Use](#), the Applicant will do so. IID will determine whether the Project should obtain water under IID's Interim Water Supply Policy (IWSP) for non-agricultural projects in addition to Schedule 7 General Industrial Water.

The IWSP, provided herein as Attachment A, designates up to 25,000 AFY of water for potential Non-Agricultural Projects within IID's water service area. As of January 2021, IID has 23,800 AF available under the IWSP for new projects such as the proposed project. The IWSP establishes a schedule for Processing Fees, Reservation Fees, and Connection Fees that change each year for all non-agricultural projects, and annual Water Supply Development fees for some non-agricultural projects. The proposed Project's water use will be subject to the annual Water Supply Development fee if IID determines that water for the Project is to be supplied under the IWSP.

The likelihood that IID will not receive its annual 3.1 MAF apportionment less QSA/Transfer Agreement obligations of Colorado River water is low due to the high priority of the IID entitlement relative to other Colorado River contractors, see IID's Water Rights section on [page 22](#). If such reductions were to come into effect within the 20-year Project life, the Applicants are to work with IID to ensure any reduction can be managed.

As such, lower Colorado River water shortage does not present a material risk to the available water supply that would prevent the County from making the findings necessary to approve this WSA. IID, like any water provider, has jurisdiction to manage the water supply within its service area and impose

conservation measures during a period of temporary water shortage. Furthermore, without the proposed Project, IID’s task of managing water supply under the QSA/Transfer Agreements would be more difficult, because agricultural use on the proposed Project site would be significantly higher than the proposed demand for the proposed Project as explained in the Expected Water Demands for the Proposed Project on the section that follows.

Water for construction (primarily for dust control) would be obtained from IID canals or laterals in conformance with IID rules and regulations for MCI temporary water use.²³ Water would be picked up from a nearby canal or lateral and delivered to the construction location by a water truck capable of carrying approximately 4,000 gallons per load. To obtain water delivery service, the Project proponent will complete an IID-410 Certificate of Ownership and Authorization (Water Card), which allows the Water Department to provide the district with information needed to manage the district apportioned supply. Water cards are used for Agriculture, Municipal, Industrial and Service Pipe accounts. If water is to be provided under IWSP in addition to Schedule 7. General Industrial Use, the Applicant will seek to enter into a IWSP Water Supply Agreement.

Expected Water Demands for the Proposed Project

Water for the Project will be needed on-site for dust control and soil condition during the 18-month construction period and for PV module washing during the 30-year operational phase (see Table 14). Untreated Colorado River water will be supplied to the project via the adjacent All American Canal under an IWSP Water Supply Agreement with IID. The Project site is currently open land and does not receive water from IID. Thus, the proposed Project water demand would be a new use within the District service area.

Project raw water uses are summarized in in Table 14.

Table 14. Project Water Uses (AFY)

Use	Acre-Feet per Year
Raw Water for construction (275 AF total over 18 months = 183.3 AFY)	183.3
Raw Water for PV module washing	10
TOTAL RAW WATER USAGE (long term)	10

IID currently does not deliver untreated Colorado River water to the proposed Project site for agricultural uses.

The proposed Project has an estimated total water demand of 460 AF or 23 AFY amortized over a 20-year term (to be pumped to water trucks directly from the All American Canal – there would be no diversion through any delivery gates for Project). Thus, the proposed Project demand is an increase of

²³ Complete the Application for Temporary Water Use and submit to Division office. Complete encroachment permit through Real Estate – non-refundable application fee of \$250, se. IID website: [Real Estate / Encroachments, Permissions, and Other Permitting](#). Fee for temporary service water: Schedule No. 7 General Industrial Use / Temporary Service Minimum charge for up to 5 AF, pay full flat fee for 5 AF at General Industrial Use rate (\$425); use more than 5 AF, pay fee for actual use at General Industrial Rate (\$85/AF).

23 AFY from the historical 10-year average. There has been no prior delivery for agricultural uses at the proposed Project site. The proposed Project’s estimated water demand of 23 AFY amortized over 20 years represents only 0.1 percent (0.1%) of the 23,800 AYF balance of supply available for contracting under the IWSP.

IID’s Ability to Meet Demands With Water Supply

Non-agricultural water demands for the IID water service area are projected for 2025-2055 in Table 5, and IID agricultural demands including system operation are projected for 2025-2055 in Table 6, all volumes within the IID water service area. IID water supplies available for consumptive use after accounting for mandatory transfers are projected to 2077 in Table 11 (Column 11), volumes at Imperial Dam.

To assess IID’s ability to meet future water demands, IID historic and forecasted demands are compared with CRWDA Exhibit B net availability, volumes at Imperial Dam Table 11 (Column 11). The analysis requires accounting for system operation consumptive use within the IID water service area, from AAC at Mesa Lateral 5 to Imperial Dam, and for water pumped for use by the USBR Lower Colorado Water Supply Project (LCRWSP), an IID consumptive use component in the USBR Decree Accounting Report. IID system operation consumptive use for 2015 is provided in Table 15 to show the components included in the calculation and their 2015 volumes.

Table 15. IID System Operations Consumptive Use within IID Water Service Area and from AAC at Mesa Lateral 5 to Imperial Dam, (KAF), 2020

	Consumptive Use (KAF)
IID Delivery System Evaporation	24.4
IID Canal Seepage	90.8
IID Main Canal Spill	10.1
IID Lateral Canal Spill	121.5
IID Seepage Interception	-39.0
IID Unaccounted Canal Water	-40.0
Total IID System Operational Use, within water service area	167.8
“Losses” from AAC @ Mesa Lat 5 to Imperial Dam	9.2
LCWSP pumpage	-10
Total System Operational Use in 2020	167.0

Source: 2020 IID Water Balance Rerun 01/25/2021

IID’s ability to meet customer water demands through 2055 as shown in Table 16 is based on the following:

- Non-agricultural use from Table 5.
- Agricultural and Salton Sea mitigation uses from Table 6.
- CRWDA Exhibit B net available for IID consumptive use from Table 11.
- System operation consumptive use from Table 15.

Table 16. IID Historic and Forecasted Consumptive Use vs CRWDA Exhibit B IID Net Available Consumptive Use, volumes at Imperial Dam (KAFY), 2015-2055 Next Update in 2026 thru 2065

	2015	2020	2025	2030	2035	2040	2045	2050	2055
Non-Ag Delivery	110.1	115.2	133.1	142.9	151.4	163.2	175.4	188.4	199.3
Ag Delivery	2,156.8	2,165.4	2,259.5	2,209.5	2,209.5	2,209.5	2,209.5	2,209.5	2,209.5
QSA SS Mitigation Delivery	153.3	0.0	0.0	0.0	0.0	0.0	0.0	0.0	0.0
System Op CU in IID & to Imperial Dam	220.2	167.0	230.5	225.4	225.4	225.4	225.4	225.4	225.4
IID CU at Imperial Dam	2,480.9	2,493.7	2,623.1	2,577.8	2,586.3	2,598.1	2,610.3	2,623.3	2,634.2
Exhibit B IID Net Available for CU at Imperial Dam	2,480.9	2,652.0	2,617.8	2,612.8	2,612.8	2,612.8	2,612.8	2,665.8	2,665.8
IID Underrun/Overrun at Imperial Dam	90.0	-98.1	-5.30	35.00	26.50	14.70	2.50	42.50	31.60

Notes: 2015 Provisional Water Balance rerun 06/28/2019
 Non-Ag Delivery CI 15.0%, Ag Delivery CI 3.0%, QSA SS mitigation CI 15%
 QSA Salton Sea Mitigation Delivery terminates on 12/31/2017
 Underrun /Overrun = IID CU at Imperial Dam minus CRWDA Exhibit B Net Available

Notes: Ag Delivery for 2020-2055 does not take into account land conversion for solar use nor reduction in agricultural land area due to urban expansion.

As shown above, IID forecasted demand has the potential to exceed CRWDA Exhibit B Net Consumptive Use volumes during several time intervals through the lifespan projection for the Project. However, due to temporary land conversion for solar use and urban land expansion that will reduce agricultural acres in the future, a water savings of approximately 217,000 AFY will be generated into the future and for the lifetime of the Project.

In addition, USBR 2020 Decree Accounting Report states that IID Consumptive Use is 2,493.7 KAF (excludes 1,579 AF of ICS storage in Lake Mead and 49,444 AF of conserved water left on the Colorado River system) with an underrun of -98.1 KAF, as reported by IID in 2020 Annual SWRCB Report per WRO 2002-2013; that is, IID uses less than the amount in its approved Water Order (2,615,300 AF).

Table 17. 2020 Approved Water Order, Actual CU (Decree Accounting Report) and IID Underrun, KAF at Imperial Dam

IID Approved Water Order	2,625.3 less 10 supplied by LCWSP and less 26 of additional conserved water
IID Consumptive Use	2,493.7
IID Underrun /Overrun	-98.1

Sources:
 2020 IID Revised Water Order, approved on March 10, 2020, 2019 Decree Accounting Report, and 2020 Annual Report of IID Pursuant to SWRCB Revised Order WRO 2002-2013

As reported in the 2019 QSA Implementation Report and 2020 SWRCB IID Report and presented in Table 17, from 2013 to 2020 IID consumptive use (CU) resulted in underruns; i.e., annual CU was less than the district’s QSA Entitlement of 3.1 MAFY minus QSA/Transfer Agreements obligations. This would indicate that even though Table 16 shows IID Overrun/Underrun at Imperial Dam exceeding CRWDA Exhibit B Net Available for CU, for the 30-year life of the proposed Project, IID consumptive use may be less than forecasted.

Meanwhile, forecasted Ag Delivery reductions presented in **Table 6** are premised on implementation of on-farm practices that will result in efficiency conservation. These reductions do not take into account land conversion for solar projects nor reduction in agricultural land area due to urban expansion; that is to say, the forecasted Ag Delivery is for acreage in 2003 with reduction for projected on-farm conservation efficiency. Thus, Ag Delivery demand may well be less than forecasted in **Table 6**. In any case, the proposed Project will use less water than the historical agricultural demand of proposed Project site, so the proposed Project will ease rather than exacerbate overall IID water demands.

In the event that IID has issued water supply agreements that exhaust the 25 KAFY IWSP set aside, and it becomes apparent that IID delivery demands due to non-agriculture use are going to cause the district to exceed its quantified 3.1 MAFY entitlement less QSA/Transfer Agreements obligations, IID has identified options to meet these new non-agricultural demands. These options include (1) tracking water yield from temporary land conversion from agricultural to non-agricultural land uses (renewable solar energy); and (2) only if necessary, developing projects to expand the size of the district's water supply portfolio.

These factors will be discussed in the next two sections, Tracking Water Savings from Growth of Non-Agricultural Land Uses and Expanding Water Supply Portfolio.

Tracking Water savings from Growth of Non-Agricultural Land Uses

The Imperial County Board of Supervisors has targeted up to 25,000 acres of agricultural lands, about 5 percent (5%) of the farmable acreage served by IID, for temporary conversion to solar farms; because the board found that this level of reduction would not adversely affect agricultural production. As reported for IID's 2020 Temporary Land Conversion Following Program, existing solar developments at the end of 2020 have converted 12,404 acres of farmland. These projects had a yield at-river of 65,964 AF of water in 2020. The balance of the 25,000-acre agriculture-to-solar policy is 12,596 acres. On average, each agricultural acre converted reduces agricultural demand by 5.1 AFY, which results in a total at-river yield (reduction in consumptive use) of 127,500 AFY.

However, due to the nature of the conditional use permits under which solar farms are developed, IID cannot rely on this supply being permanently available. In fact, should a solar project decommission early, that land may go immediately back to agricultural use (it remains zoned an agricultural land). Nevertheless, during their operation, the solar farms do ameliorate pressure on IID to implement projects to meet demand from new non-agricultural projects.

Unlike the impact of solar projects, other non-agricultural uses are projected to grow, as reflected in the nearly 55 percent (55%) increase in non-agricultural water demand from 107.4 KAF in 2015 to 201.4 KAF in 2055 reflected herein in Table 5 This increase in demand of 94 KAFY will more than likely be met by solar development; however, as the land remains zoned as agricultural land, that source is not reliable to be permanently available to IID.

The amount of land developed for residential, commercial, and industrial purposes is projected to grow by 55,733 acres from 2015 to 2050²⁴ within the sphere of influence of the incorporated cities and specific plan areas in Imperial County. A conservative estimate is that such development will displace at least another 24,500 acres of farmland based on the Imperial Local Agency Formation Commission (LAFCO) sphere of influence maps and existing zoning and land use in Imperial County. At 5.13 AFY yield at-river, there would be a 125,000 AFY reduction IID net consumptive use.

The total foreseeable solar project temporary yield at-river (91,800 AFY) and municipal development permanent yield at-river (125,000 AFY) is to reduce forecasted IID net consumptive use at-river 216,800 AFY, which is more than enough to meet the forecast Demand minus Exhibit B Net Available volumes shown in Table 11. This Yield at-river is sufficient to meet the forecasted excess of non-agricultural use over Net Available supply within the IID service area for the next 20 years, as is required for SB 610 analysis.

Farmland retirement associated with municipal development would reduce IID agricultural delivery requirements beyond the efficiency conservation projections shown in **Table 6** and Table 16. Therefore, in the event that [Schedule 7 General Industrial Use](#) water is unavailable, the Applicants will rely on IID IWSP water to supply the Project, as discussed above in the Projected Water Availability section.

Expanding Water Supply Portfolio

While forecasted long-term annual yield-at-river from the reduction in agricultural acreage due to municipal development in the IID service area is sufficient to meet the forecasted excess of non-agricultural use over CRWDA Net Available supply (Table 11) without expanding IID's Water Supply Portfolio, IID has also evaluated the feasibility of a number of capital projects to increase its water supply portfolio.

As reported in [2012 Imperial IRWMP Chapter 12](#), IID contracted with GEI Consultants, Inc. to identify a range of capital project alternatives that the district could implement. Qualitative and quantitative screening criteria and assumptions were developed in consultation with IID staff. Locations within the IID water service area with physical, geographical, and environmental characteristics most suited to implementing short- and long-term alternatives were identified. Technical project evaluation criteria included volumes of water that could be delivered and/or stored by each project, regulatory and permitting complexity, preliminary engineering components, land use requirements, and costs.

After preliminary evaluation, a total of 27 projects were configured:

- 17 groundwater or drain water desalination
- 2 groundwater blending
- 6 recycled water
- 1 groundwater banking

²⁴ IRWMP, Chapter 5, Table 5-14.

- 1 IID system conservation (concrete lining)

Projects were assessed at a reconnaissance level to allow for comparison of project costs. IID staff and the board identified key factors to categorize project alternatives and establish priorities. Lower priority projects were less feasible due to technical, political, or financial constraints. Preferential criteria were features that increased the relative benefits of a project and grant it a higher priority. Four criteria were used to prioritize the IID capital projects:

1. **Financial Feasibility.** Projects whose unit cost was more than \$600/AF were eliminated from further consideration.
2. **Annual Yield.** Project alternatives generating 5,000 AF or less of total annual yield were determined not to be cost-effective and lacking necessary economies of scale.
3. **Groundwater Banking.** Groundwater banking to capture and store underruns is recognized as a beneficial use of Colorado River water. Project alternatives without groundwater banking were given a lower priority.
4. **Partnering.** Project alternatives in which IID was dependent on others (private and/or public agencies) for implementation were considered to have a lower priority in the IID review; this criterion was reserved for the IRWMP process, where partnering is a desirable attribute.

Based on these criteria, the top ten included six desalination, two groundwater blending, one system conservation, and one groundwater storage capital projects. These capital projects are listed in Table 18 which follows.

Table 18. IID Capital Project Alternatives and Cost (May 2009 price levels \$)

Name	Description	Capital Cost	O&M Cost	Equivalent Annual Cost	Unit Cost (\$/AF)	In-Valley Yield (AF)
GW 18	Groundwater Blending E. Mesa Well Field Pumping to AAC	\$39,501,517	\$198,000	\$2,482,000	\$99	25,000
GW 19	Groundwater Blending: E. Mesa Well Field Pumping to AAC w/Percolation Ponds	\$48,605,551	\$243,000	\$3,054,000	\$122	25,000
WB 1	Coachella Valley Groundwater Storage	\$92,200,000	\$7,544,000	\$5,736,746	\$266	50,000
DES 8	E. Brawley Desalination with Well Field and Groundwater Recharge	\$100,991,177	\$6,166,000	\$12,006,000	\$480	25,000
AWC 1	IID System Conservation Projects	\$56,225,000	N/A	\$4,068,000	\$504	8,000
DES 12	East Mesa Desalination with Well Field and Groundwater Recharge	\$112,318,224	\$6,336,000	\$12,831,000	\$513	25,000
DES 4	Keystone Desalination with IID Drain water/ Alamo River	\$147,437,743	\$15,323,901	\$23,849,901	\$477	50,000
DES 14	So. Salton Sea Desalination with Alamo River Water and Industrial Distribution	\$158,619,378	\$15,491,901	\$24,664,901	\$493	50,000
DES 15	So. Salton Sea Desalination with Alamo River Water and MCI Distribution	\$182,975,327	\$15,857,901	\$26,438,901	\$529	50,000

Name	Description	Capital Cost	O&M Cost	Equivalent Annual Cost	Unit Cost (\$/AF)	In-Valley Yield (AF)
DES 2	Keystone Desalination with Well Field and Groundwater Recharge	\$282,399,468	\$13,158,000	\$29,489,000	\$590	50,000

Source: Imperial IRWMP, Chapter 12; see also Imperial IRWMP Appendix N, IID Capital Projects

IID Near Term Water Supply Projections

As mentioned above, IID’s quantified Priority 3(a) water right under the QSA/Transfer Agreements secures 3.1 MAF per year, less transfer obligations of water for IID’s use from the Colorado River, without relying on rainfall in the IID service area. Even with this strong entitlement to water, IID actively promotes on-farm efficiency conservation and is implementing system efficiency conservation measures including seepage recovery from IID canals and the All-American Canal (ACC) and measures to reduce operational discharge. As the IID website [Water Department](#) states:

Through the implementation of extraordinary conservation projects, the development of innovative efficiency measures and the utilization of progressive management tools, the IID Water Department is working to ensure both the long-term viability of agriculture and the continued protection of water resources within its service area.

Overall, agricultural water demand in the Imperial Valley will decrease due to IID system and grower on-farm efficiency conservation measures that are designed to maintain agricultural productivity at pre-QSA levels while producing sufficient yield-at-river to meet IID’s QSA/Transfer Agreements obligations. These efficiencies combined with the conversion of some agricultural land uses to non-agricultural land uses (both solar and municipal), ensure that IID can continue to meet the water delivery demand of its existing and future agricultural and non-agricultural water users, including this Project for the next 20 years and for the life of the proposed Project.

IMPERIAL IRRIGATION DISTRICT FINDINGS

IID serves as the regional wholesale water supplier, importing raw Colorado River water and delivering it, untreated, to agricultural, municipal, industrial, environmental and recreational water users within its Imperial Unit water service area. Imperial County Planning and Development Services serves as the responsible agency with land use authority over the proposed project. Water Assessment findings are summarized as follows:

1. IID's annual entitlement to consumptive use of Colorado River water is capped at 3.1 MAF less water transfer obligations, pursuant to the QSA and Related Agreements. Under the terms of the CRWDA, IID is implementing efficiency conservation measure to reduce net consumptive use of Colorado River water needed to meet its QSA/Transfer Agreements obligations while retaining historical levels of agricultural productivity.
2. In 2020 IID consumptively used 2,493,661 AF of Colorado River water (volume at Imperial Dam); 2,278,598 AF were delivered to customers (including recreational and environmental water deliveries) of which 2,165,386 AF or 95 percent went to agricultural users as per IID's Water Balance run on 1/25/2021.
3. Reduction of IID's net consumptive use of Colorado River water under the terms of the Colorado River Water Delivery Agreement is to be the result of efficiency conservation measures. Agricultural consumptive use in the Imperial Valley will not decline. However, IID operational spill and tailwater will decline, impacting the Salton Sea.
4. Due to the dependability of IID's water rights, Colorado River flows, and Colorado River storage facilities for Colorado River water, it is unlikely that the water supply of IID would be disrupted, even in dry years or under shortage conditions because Mexico, Arizona and Nevada have lower priority and are responsible for reducing their water use during a declared Colorado River water shortage before impacting California.
5. Historically, IID has never been denied the right to use the annual volume of water it has available for its consumptive uses under its entitlement. Nevertheless, IID is participating in discussions for possible actions in response to extreme drought on the Colorado River.
6. The proposed Project has an estimated total water demand of 460 AF or 23 AFY amortized over a 20-year term. Water would typically be pumped from the All-American Canal by water trucks and not delivered through an existing gate. While the initial 18-month construction demand would be 275 AF, the on-going demand over the life of the Project would be 10 AFY. Thus, the proposed Project demand is an increase of 23 AFY from the historical 10-year average.
7. The Project's water use will be covered under the Schedule 7 General Industrial Use. In the event that IID determines that the proposed Project is to utilize IWSP for Non-Agricultural Projects water, the Applicant will enter into an IWSP Water Supply Agreement with IID. In which case, the proposed Project would use 0.1 percent (0.1%) of the 23,800 AYF of IWSP water.

8. Based on the Environmental Impact Report (EIR) prepared for this proposed Project pursuant to the CEQA, California Public Resources Code sections 21000, *et seq.* (SCH No. 2021050018), the Lead Agency hereby finds that the IID projected water supply will be sufficient to satisfy the demands of this proposed Project in addition to existing and planned future uses, including agricultural and non-agricultural uses for a 20-year Water Supply Assessment period and for the 30 -year proposed Project life.
-

ASSESSMENT CONCLUSION

This Water Supply Assessment has determined that IID water supply is adequate for the Vega SES 4, LLC VEGA SES 4 Solar Energy Storage project (proposed Project). The Imperial Irrigation District's IWSP for Non-Agricultural Projects dedicates 25,000 AF of IID's annual water supply to serve new projects. As of January 2021, 23,800 AF per year remain available for new projects ensuring reasonably sufficient supplies for new non-agricultural water users. The project water demand of approximately 23 AFY amortized over 20 years represents 0.1 % of the unallocated supply set aside in the IWSP for non-agricultural project, and approximately 0.01 percent (0.01 %) of forecasted future non-agricultural water demands planned in the Imperial IRWMP through 2055. There has been no prior agricultural water use at the Project site.

For all the reasons described herein, the amount of water available and the stability of the IID water supply along with on-farm and system efficiency conservation and other measures being undertaken by IID and its customers ensure that Vega SES 4, LLC's water needs will be met for the next 20 years as assessed for compliance under SB-610.

RESOURCES AND REFERENCES

1. California Department of Water Resources. (2003). [Guidebook for Implementation of Senate Bill 610 and Senate Bill 221 of 2001](#) to assist water suppliers, cities, and counties in integrating water and land use planning.
2. Imperial County Planning and Development Services. (2008). Imperial County General Plan 2008 Update. El Centro, CA.
3. Imperial Irrigation District. Website: [Equitable Distribution](#).
4. Imperial Irrigation District Website: [Water Conservation Plan](#). (2008). Imperial Irrigation District 2007 Water Conservation Plan. Imperial, CA.
5. Imperial Irrigation District. (2004). IID [Interactive GIS Water Service Area Map](#). Imperial, CA.
6. Imperial Irrigation District. (2009). [Interim Water Supply Policy for Non-Agricultural Projects](#). Imperial, CA
7. Imperial Irrigation District. (2012). [Temporary Land Conversion Following Policy \(TLFCP\) for Water Conservation Yield](#) Water conservation yield attributable to land removed from agricultural production and temporarily fallowed. Updated March 27, 2018.
8. Imperial Irrigation District Water Department. (2013). [Colorado River Water Accounting and Conservation Commitments Update](#). Tina Anderholt Shields, PE. Colorado River Resources Manager Imperial, CA.
9. Imperial Irrigation District. (2017). [2016 QSA Water Conservation & Transfer Agreement Annual Implementation Report](#), Imperial, CA
- 10.
11. Imperial Irrigation District. (2017). Consultation with Anisa J Divine, Ph.D., Senior Planner. Imperial, CA.
12. Imperial Irrigation District. (2017). [Temporary Land Following Conversion Policy. \(TLFCP\)](#).
- 13.
14. Imperial Irrigation District. (2018). [2017 IID SWRCB Report](#).
15. United States Bureau of Reclamation Lower Colorado Region Website: [Boulder Canyon Operations Office – Programs and Activities](#), Lower Colorado River Water Accounting, Water Accounting Reports (1964 - 2015). Compilation of Records in Accordance with Article V of the Decree of the Supreme Court of the United States in Arizona v. California Dated March 9, 1964: Calendar Years 1964 - 2015 Boulder City, NV.

ATTACHMENTS

Attachments

Attachment A: IID Interim Water Supply Policy for Non-Agricultural Projects

(This page intentionally left blank)

ATTACHMENT A: IID INTERIM WATER SUPPLY POLICY FOR NON-AGRICULTURAL PROJECTS²⁵

1.0 Purpose.

Imperial Irrigation District (the District) is developing an Integrated Water Resources Management Plan (IWRMP)²⁶ that will identify and recommend potential programs and projects to develop new water supplies and new storage, enhance the reliability of existing supplies, and provide more flexibility for District water department operations, all in order to maintain service levels within the District's existing water service area. The first phase of the IWRMP is scheduled to be completed by the end of 2009 and will identify potential projects, implementation strategies and funding sources. Pending development of the IWRMP, the District is adopting this Interim Water Supply Policy (IWSP) for Non-Agricultural Projects, as defined below, in order to address proposed projects that will rely upon a water supply from the District during the time that the IWRMP is still under development. It is anticipated that this IWSP will be modified and/or superseded to take into consideration policies and data developed by the IWRMP.

2.0 Background.

The IWRMP will enable the District to more effectively manage existing water supplies and to maximize the District's ability to store or create water when the available water supplies exceed the demand for such water. The stored water can be made available for later use when there is a higher water demand. Based upon known pending requests to the District for water supply assessments/verifications and pending applications to the County of Imperial for various Non-Agricultural Projects, the District currently estimates that up to 50,000 acre feet per year (AFY) of water could potentially be requested for Non-Agricultural Projects over the next ten to twenty years. Under the IWRMP the District shall evaluate the projected water demand of such projects and the potential means of supplying that amount of water. This IWSP currently designates up to 25,000 AFY of water for potential Non-Agricultural Projects within IID's water service area. Proposed Non-Agricultural projects may be required to pay a Reservation Fee, further described below. The reserved water shall be available for other users until such Non-Agricultural projects are implemented and require the reserved water supply. This IWSP shall remain in effect pending the approval of further policies that will be adopted in association with the IWRMP.

3.0 Terms and Definitions.

3.1 Agricultural Use. Uses of water for irrigation, crop production and leaching.

²⁵ IID Board Resolution 31-2009. Interim Water Supply Policy for New Non-Agricultural Projects. September 29, 2009. <IID [Interim Water Supply Policy for Non-Agricultural Projects](#)>

²⁶ The 2009 Draft IID IWRMP has been superseded by the October 2012 Imperial IRWMP, which incorporates the conditions of the IWSP by reference.

3.2 **Connection Fee.** A fee established by the District to physically connect a new Water User to the District water system.

3.3 **Industrial Use.** Uses of water that are not Agricultural or Municipal, as defined herein, such as manufacturing, mining, cooling water supply, energy generation, hydraulic conveyance, gravel washing, fire protection, oil well re-pressurization and industrial process water.

3.4 **Municipal Use.** Uses of water for commercial, institutional, community, military, or public water systems, whether in municipalities or in unincorporated areas of Imperial County.

3.5 **Mixed Use.** Uses of water that involve a combination of Municipal Use and Industrial Use.

3.6 **Non-Agricultural Project.** Any project which has a water use other than Agricultural Use, as defined herein.

3.7 **Processing Fee.** A fee charged by the District Water Department to reimburse the District for staff time required to process a request for water supply for a Non-Agricultural Project.

3.8 **Reservation Fee.** A non-refundable fee charged by the District when an application for water supply for a Non-Agricultural Project is deemed complete and approved. This fee is intended to offset the completion of the application to start-up of construction of the proposed project and/or execution of a water supply agreement. The initial payment of the Reservation Fee will reserve the projected water supply for up to two years. The Reservations Fee is renewable for up to two additional two-year periods upon payment of an additional fee for each renewal.

3.9 **Water Supply Development Fee.** An annual fee charged to some Non-Agricultural Projects by the District, as further described in Section 5.2 herein. Such fees shall assist in funding IWRMP or related water supply projects,

3.10 **Water User.** A person or entity that orders or receives water service from the District.

4.0. CEQA Compliance.

4.1 The responsibility for CEQA compliance for new development projects within the unincorporated area of the County of Imperial attaches to the County of Imperial or, if the project is within the boundaries of a municipality, the particular municipality, or if the project is subject to the jurisdiction of another agency, such as the California Energy Commission, the particular agency. The District will coordinate with the County of Imperial, relevant municipality, or other agency to help ensure that the water supply component of their respective general plans is comprehensive and based upon current information. Among other things, the general plans should assess the direct, indirect and cumulative potential impacts on the environment of using currently available water supplies for new industrial, municipal, commercial and/or institutional uses instead of the historical use of that water for agriculture. Such a change in land use, and the associated water use, could potentially impact land uses, various aquatic and terrestrial species, water quality, air quality and the conditions of drains, rivers and the Salton Sea.

4.2 When determining whether to approve a water supply agreement for any Non-Agricultural Project pursuant to this IWSP, the District will consider whether potential environmental and water supply impacts of such proposed projects have been adequately assessed, appropriate mitigation has been developed and appropriate conditions have been adopted by the relevant land use permitting/approving agencies, before the District approves any water supply agreement for such project.

5.0. Applicability of Fees for Non-Agricultural Projects.²⁷

5.1 Pursuant to this Interim Water Supply Policy, applicants for water supply for a Non-Agricultural Project shall be required to pay a Processing Fee and may be required to pay a Reservation Fee as shown in Table A. All Water Users shall also pay the applicable Connection Fee, if necessary, and regular water service fees according to the District water rate schedules, as modified from time to time.

5.2 A Non-Agricultural Project may also be subject to an annual Water Supply Development Fee, depending upon the nature, complexity, and water demands of the proposed project. The District will determine whether a proposed Non-Agricultural Project is subject to the Water Supply Development Fee for water supplied pursuant to this IWSP as follows:

5.2.1. A proposed project that will require water for a Municipal Use shall be subject to an annual Water Supply Development Fee as set forth in Table B if the projected water demand for the project is in excess of the project's estimated population multiplied by the District-wide per capita usage. Municipal Use projects without an appreciable residential component will be analyzed under sub-section 5.2.3.

5.2.2. A proposed project that will require water for an Industrial Use located in an unincorporated area of the County of Imperial shall be subject to an annual Water Supply Development Fee as set forth in Table B.

5.2.3. The applicability of the Water Supply Development Fee set forth in Table B to Mixed Use projects, Industrial Use projects located within a municipality, or Municipal Use projects without an appreciable residential component, will be determined by the District on a case-by-case basis, depending upon the proportion of types of land uses and the water demand proposed for the project.

5.3. A proposed Water User for a Non-Agricultural Projects may elect to provide some or all of the required water supply by paying for and implementing some other means of providing water in a manner approved by the District, such as conservation projects, water storage projects and/or use of an alternative source of supply, such as recycled water or some source of water other than from the District water supply. Such election shall require consultation with the District regarding the details of such alternatives and a determination by the District, in its reasonable discretion, concerning how much credit, if any, should be given for such alternative water supply as against the project's water demand for purposes of determining the annual Water Supply Development Fee for such project.

²⁷ The most recent fee schedules can be found in a link at IID/Water/ Municipal, Industrial and Commercial Customers; or visit by URL at [Imperial Irrigation District : Water Rate Schedules](#)

5.4 The District Board shall have the right to modify the fees shown on Tables A and B from time to time.

6. Water Supply Development Fees collected by the District under this IWSP shall be accounted for independently, including reasonable accrued interest, and such fees shall only be used to help fund IWRMP or related District water supply projects.

7. Any request for water service for a proposed Non-Agricultural Project that meets the criteria for a water supply assessment pursuant to Water Code Sections 10910-10915 or a water supply verification pursuant to Government Code Section 66473.7 shall include all information required by Water Code Sections 10910–10915 or Government Code Section 66473.7 to enable the District to prepare the water supply assessment or verification. All submittals should include sufficient detail and analysis regarding the project’s water demands, including types of land use and per capita water usage, necessary to make the determinations outlined in Section 5.2.

8. Any request for water service for a proposed Non-Agricultural Project that does not meet the criteria for a water supply assessment pursuant to Water Code Section 10910-10915 or water supply verification pursuant to Government Code Section 66473.7 shall include a complete project description with a detailed map or diagram depicting the footprint of the proposed project, the size of the footprint, projected water demand at full implementation of the project and a schedule for implementing water service. All submittals should include sufficient detail and analysis regarding the project’s water demands, including types of land use and per capita water usage, necessary to make the determinations outlined in Section 5.2.

9. All other District rules and policies regarding a project applicant or Water User's responsibility for paying connection fees, costs of capital improvements and reimbursing the District for costs of staff and consultant's time, engineering studies and administrative overhead required to process and implement projects remain in effect.

10. Municipal Use customers shall be required to follow appropriate water use efficiency best management practices (BMPs), including, but not limited to those established by the California Urban Water Conservation Council BMP’s (see <http://www.cuwcc.org/mou/exhibit-1-bmp-definitions-schedules-requirements.aspx>), or other water use efficiency standards, adopted by the District or local government agencies.

11. Industrial Use customers shall be required to follow appropriate water use efficiency BMP’s, including but not limited to those established by the California Urban Water Conservation Council and California Energy Commission, as well as other water use efficiency standards, adopted by the District or local government agencies.

12. The District may prescribe additional or different BMPs for certain categories of Municipal and Industrial Water Users.

(This page intentionally left blank)

**Attachment C:
FEIR – FINDINGS-ERRATA**

VEGA SES 4 Solar Energy Project Errata to the Draft EIR For Proposed Grays Wells Road Heavy Construction Equipment/Vehicle Access

A. INTRODUCTION

The VEGA SES 4 Draft EIR analyzed a heavy construction equipment/vehicle access route to the project site via Gordon Wells Road. Subsequent to the preparation of the VEGA SES 4 Draft EIR, the project applicant has identified a potential second heavy construction equipment/vehicle access option via Grays Wells Road, a portion of which, was not contemplated in the Draft EIR analysis. The following provides a description of the Gordon Wells Road heavy construction equipment/vehicle access as analyzed in the Draft EIR and the secondary heavy construction equipment/vehicle access option via Grays Wells Road. This Errata indicates where minor revisions to the Draft EIR would be required in order to incorporate the Grays Wells Road access option and provides a corresponding environmental analysis of this second heavy construction equipment/vehicle access option. Based on the project description of the Grays Wells Road heavy construction equipment/vehicle access option and corresponding environmental analysis, the County has determined that an Errata is the appropriate CEQA documentation to address the potential access route, and that no new significant impacts or recirculation of the Draft EIR is required.

Gordon Wells Road - Heavy Construction Equipment/Vehicle Access. The VEGA SES 4 Solar Energy Project Final EIR, State Clearinghouse No. 2021050018 ("Final EIR"), describes potential environmental impacts resulting from the use of a heavy construction equipment/vehicle construction access route that would obtain access to the project site from Gordon Wells Road indirectly off of the I-8 Freeway. As stated in the Final EIR, Section 2.4.2 Heavy Construction Equipment Access (Final EIR page 2-10), it was determined heavy construction vehicles would cross the All-American Canal at Gordon Wells Road located approximately 20 miles east of the project site. Final EIR **Error! Reference source not found.** (Final EIR page 2-13) depicts the proposed route. This route is approximately 20-miles in length. With this heavy vehicle access option, access for heavy construction vehicles to and from the project site requires crossing the All-American Canal, via two existing bridges as shown in Final EIR **Error! Reference source not found.** These two bridges are located along Gordon Wells Road. Gordon Wells Road has an interchange with I-8. The bridges over the canal were constructed in 2009. The bridges are rated as open with no restrictions and have a "Good" condition rating.

An estimated two trucks would arrive at the project site each day during the first few weeks of construction of the solar facility.

Grays Wells Road – Heavy Construction Equipment/Vehicle Access (Second Option). Subsequent to circulation of the Draft EIR, a potential second option has been identified by the project applicant based

May 5, 2023

PC ORIGINAL PKG

on further discussions with IID, the Border Patrol/Department of Homeland Security, and the Bureau of Land Management (BLM). The second access option would take access off of Grays Wells Road and has a direct connection via the I-8. The route is approximately 27 miles in length. As with the Gordon Wells Road access, this option would require the applicant to obtain appropriate right of way (ROW) approvals from the BLM and approvals from the Border Patrol. This access option would utilize a paved frontage road that starts east of the All American Canal and extends east to the existing I-8 rest stop and BLM desert office. There is a gap between that frontage road and the border road that currently is a dirt trail which the project applicant would construct minimal improvements sufficient to carry large vehicles, but not be paved per request of the BLM. The proposed area to be graded (that is not otherwise paved frontage road or existing border patrol dirt road) is approximately 1.43 miles in length.

As noted above, either access option (Gordon Wells Road or Grays Wells Road), heavy vehicle access will require approvals by the BLM and Border Patrol/Department of Homeland Security. As indicated in the Draft EIR, the applicant has entered into a Memorandum of Understanding with the U.S. Border Patrol setting forth the project-related activities that may occur on this existing dirt road used by the U.S. Border Patrol.

The following ROW requests have been brought forward by the project applicant to the BLM in support of this project, which address both the Gordon Wells Road and Grays Wells Road access options, although the Grays Wells Road access would involve additional ROW approvals by BLM specifically for the heavy vehicle access routes include:

- 60 foot wide ROW for the existing direct frontage road that parallels the international border/fence
- 60 foot wide ROW for the existing paved frontage road between the I-8 rest stop/BLM Desert office and the border road. This area is currently a desert dirt trail used extensively by off road vehicles.
- **Heavy Construction Equipment Access:** Vendors and heavy construction equipment would exit both from the south and north from Interstate 8 onto Greys Wells Road approximately 24miles east of the project site, then travel west along an and existing paved road that ends at a cul-de-sac. From the cul-de-sac, a short section of an existing dirt road would connect to the existing dirt road paralleling the U.S./Mexico Border. The connecting dirt road between the paved road and the border road would be improved to BLM requirements.
- **Right of Way.** The ROW that is being requested for the border road as well as the transition to the paved road and the paved road only needs to be the width of the existing roads and is currently calculated at no more than 60 feet.

The minor re-alignment of a proposed access road would also not result in an increase in any impact already addressed in the Draft EIR.

This section of the Final Environmental Impact Report (EIR) identifies the location of, or contains revisions to, information included in the Draft EIR. The information added to the EIR does not meet the requirements for recirculation pursuant to Section 15088.5 of the State *California Environmental Quality Act (CEQA) Guidelines*. The new information simply clarifies information presented in the Draft EIR. Text

May 5, 2023

that has been added to the document appears in an underline format. Text that has been deleted appears with strikeout.

This Errata, in conjunction with the Final EIR, will be used by the County of Imperial in its evaluation and analysis of the proposed project and in the adoption of any findings required by law. Substantial evidence in support of findings may be found anywhere in the administrative record. (14CCR 15091(b)(e). The County of Imperial is designated the Lead Agency for California Environmental Quality Act (CEQA) compliance.

This Errata provides further detail as to this potential heavy vehicle access option.

B. CORRECTIONS AND ADDITIONS

SECTION 1 INTRODUCTION

Page 1-3

1.1.1 Agency Roles and Responsibilities

Federal

United States Border Patrol

- The project applicant and U.S. Border Patrol will develop and enter into a Memorandum of Understanding (MOU) setting forth the project-related activities that may occur on an existing dirt road used by the U.S. Border Patrol.

Bureau of Land Management – California Desert District U.S. Department of the Interior – Region 8 El Centro Field Office

- The project applicant will be required to obtain a Right of Way (ROW) from the Bureau of Land Management (BLM) for any heavy construction equipment/vehicle access routes that may traverse BLM managed public lands. Should the proposed Gordon Wells Road heavy equipment access route not be utilized, a second option is proposed utilizing Grays Wells Road as described in further detail in Chapter 2 Project description.

SECTION 2 PROJECT DESCRIPTION

Page 2-9:

Heavy Construction Equipment Access: Vendors and heavy construction equipment would exit south from Interstate 8 onto Gordon Wells Road approximately 20 miles east of the project site, then travel west along an existing dirt road paralleling the U.S./Mexico Border (**Error! Reference source not found.**). See Section 2.4.2 for a detailed description of this access route for heavy construction equipment. The applicant has entered into a Memorandum of Understanding with the U.S. Border Patrol setting forth the project-related activities that may occur on this existing dirt road used by the U.S. Border Patrol (see Section 2.7.3 for a detailed discussion). The second option for means of access to be used for heavy truck loads would be along the border frontage road used by Home Land Security/Border Protection primarily. This road however does not connect directly to the I-8 corridor. Therefore; an additional connection is required east of Gordons Well where another (paved) frontage road starts east of the All American Canal

May 5, 2023

PC ORIGINAL PKG

and goes east to the I – 8 rest stop, and BLM desert office. There is a gap between that frontage road and the border road that currently is a dirt trail which the proponent would improve with minimal improvements sufficient to carry large vehicles, but not be paved per request of the BLM. This proposed route is shown in Figure 2-6b.

Page 2-10

2.4.2 Heavy Construction Equipment Access

Following discussions with the IID, it was determined heavy construction vehicles would cross the All-American Canal at Gordon Wells Road located approximately 20 miles east of the project site (**Error! Reference source not found.**). Access for heavy construction vehicles to and from the project site requires crossing the All-American Canal, via two existing bridges (**Error! Reference source not found.**), located along Gordon Wells Road. Gordon Wells Road has an interchange with I-8. The bridges over the canal were constructed in 2009. The bridges are rated as open with no restrictions and have a “Good” condition rating. The second option for means of access to be used for heavy truck loads would be along the border frontage road used by Home Land Security/Border Protection primarily. This road however does not connect directly to the I-8 corridor. Therefore an additional connection is required east of Gordons Well where another (paved) frontage road starts east of the All American Canal and goes east to the I – 8 rest stop, and BLM desert office. There is a gap between that frontage road and the border road that currently is a dirt trail which the proponent would improve with minimal improvements sufficient to carry large vehicles, but not be paved per request of the BLM. This proposed route is shown in Figure 2-6b.

Page 2-19

2.7.4 Bureau of Land Management – California Desert District U.S. Department of the Interior – Region 8 El Centro Field Office

The project applicant will be required to obtain a Right of Way (ROW) from the Bureau of Land Management (BLM) for any heavy equipment access routes that may traverse BLM managed public lands. Should the proposed Gordon Wells Road heavy equipment access route not be utilized, a second option is proposed utilizing Grays Wells Road as described in further detail in Chapter 2 Project description.

Section 3.4 Air Quality

Page 3.4-14

Methodology

All heavy-duty construction vehicles would cross the All-American Canal at Gordon Wells Road located approximately 20 miles east of the project site. An estimated two trucks hauling construction equipment and project materials would arrive at the project site each day during the first few weeks of construction via Gordon Wells Road and the 20 miles of existing dirt road paralleling the U.S./Mexico Border. The PM emissions associated with two haul trucks traversing this existing dirt road to and from the site daily are accounted for. Use of either heavy equipment access Option 1 or Option 2 (i.e., via Gordon Wells Road or via Grays Wells Road) would require implementation of the same dust control measure and construction equipment emissions reduction measures as required by Mitigation Measures AQ-1 through AQ-3. The Grays Wells Road is paved, with the exception of an 1.43-mile length segment that would be graded in

addition to what would otherwise be required for the Gordon Wells Road option, which was evaluated in the Draft EIR. This minor increase in grading would not result in an increase in construction emissions that would exceed ICAPCD significance thresholds. As identified in Draft EIR Table 3.4-8 Project Construction-Generated Emissions – Mitigated, mitigated construction emissions are well below the threshold criteria for criteria pollutants – include PM10 and PM2.5. The use of an additional 1.43-mile length for unpaved construction access would not significantly increase the daily emissions.

Page 3.4-14

- **Heavy Construction Equipment Access:** Vendors and heavy construction equipment would exit south from Interstate 8 onto Gordon Wells Road approximately 20 miles east of the project site, then travel west along an existing dirt road paralleling the U.S./Mexico Border. The second option for means of access to be used for heavy truck loads would be along the border frontage road used by Home Land Security/Border Protection primarily. This road however does not connect directly to the I-8 corridor. Therefore; an additional connection is required east of Gordons Well where another (paved) frontage road starts east of the All American Canal and goes east to the I – 8 rest stop, and BLM desert office. There is a gap between that frontage road and the border road that currently is a dirt trail which the proponent would improve with minimal improvements sufficient to carry large vehicles, but not be paved per request of the BLM.

Section 3.5 Biological Resources

Page 3.5-13

Urban/Developed

Urban/Developed areas do not constitute a vegetation classification, but rather a land cover type. Areas mapped as developed have been constructed upon or otherwise physically altered to an extent that natural vegetation communities are no longer supported. There may be irrigated landscaped, ornamental species present between the hardscape. On the project site, this land cover was dominant and consisted primarily of compacted dirt roads, structures, and landscape trees including Mexican fan palm (*Washingtonia robusta*) and Mexican palo verde (*Parkinsonia aculeata*). The entirety of the Gordon Wells Road heavy vehicle access road (Option 1) is this land cover type. The majority of the Grays Wells Road heavy vehicle access road (Option 2) is Urban/Developed (paved road) and Urban/Developed – Dirt Road. However, a 1.43-mile segment would traverse creosote bush scrub, disturbed creosote bush scrub, and/or creosote bush-white bursage scrub.

Page 3.5-36

The palm trees located within the project site may provide roosting habitats for bat species, particularly western yellow bat, a SSC species. These trees could function as maternity roost sites for this species. During the 2022 assessment of the access road, a bat roost was observed within the bridge at Gordon Wells Road that crosses the offline storage canal, north of the All-American Canal. Bat species in California are protected by Section 4150 (protection of non-game mammals from take) of the California Fish and Game Code. Section 4150 of the California Fish and Game Code prohibits the take of any naturally occurring mammals in California that are nongame mammals, which includes all species of the Order Chiroptera (bats). Based on the quantity of bats within the bridge and the timing of the observation of the colony, there is high likelihood that this is a maternity roost. If implemented as a heavy equipment access route, the Gordon Wells Road bridge will be used for access

May 5, 2023

to the solar field portion of the project site and no direct impacts are expected to occur to the bridge. However, there may be indirect impacts to the roost through noise and vibration, due to a temporary increase in traffic above the bridge during construction. However, because the bridge currently functions as an active roadway, the colony would be expected to be accustomed to noise and vibrations associated with traffic and indirect impacts would not be expected to be significant. The solar facility site is located approximately 22 miles west of the bridge and work is expected to occur within a 12-month period. An increase in truck traffic over the bridge to facilitate construction of the project is not expected to have a significant impact on the bat colony and will be temporary in nature. If the Gray Wells Road heavy equipment access route is utilized, there would be no vehicles utilizing the Gordon Wells Road bridge and therefore would avoid any potential indirect impacts to bats.

Page 3.5-37

Special Status Wildlife

CONSTRUCTION ACCESS ROAD

During construction, vendors and heavy construction equipment would access the project site via either Gordon Wells Road approximately 20 miles east of the project site, or Gray Wells Road east of the project site. For each of these options, vehicles would traverse existing paved roads and existing dirt roads. Each option would travel then travel west along an existing dirt road paralleling the U.S./Mexico Border for the majority of the route. This existing dirt road is actively used by the U.S. Border Patrol during patrol operations. The dirt road is on urban/developed land. The use of this access road during construction is not anticipated to result in potential impacts on biological resources, with the exception of roosting bats, if present only in the circumstance where the Gordon Wells Bridge would be traversed under the Gordon Wells Road option. Bat acoustic surveys and monitoring should be implemented to determine if sensitive bat species occur within the Gordon Road Wells bridge or palm trees (if planned for removal). All bat species with potential for occurrence for the project are SSC species and potential project-related impacts to bat species and bat maternity roosts are considered significant. Implementation of BIO-7 would reduce impacts to bat species and maternity roosts to a level less than significant.

Because vehicles and construction equipment would be required to stay within the existing boundaries of the existing paved road and existing dirt road to avoid and/or minimize ground disturbance to undisturbed and vegetated areas, other impacts to biological resources are not anticipated. Furthermore, the project applicant would not make improvements to the existing dirt road except for the application of water for dust suppression.

Page 3.5-43

Impact 3.5-2 Riparian Habitat and Sensitive Natural Communities

CONSTRUCTION ACCESS ROAD

The existing dirt access road is on urban/developed land. No riparian habitat or sensitive natural communities are located within or adjacent to the access road. The majority of the Grays Wells Road heavy vehicle access road (Option 2) is Urban/Developed (paved road) and Urban/Developed – Dirt Road. However, a 1.43-mile segment would traverse creosote bush scrub, disturbed creosote bush scrub, and/or creosote bush-white bursage scrub. The access road would not traverse any identified riparian habitats. Therefore, the use of the access road during construction would have no impact on riparian or sensitive natural communities.

May 5, 2023

Impact 3.5-3 State or Federally Protected Wetlands

CONSTRUCTION ACCESS ROAD

CONSTRUCTION ACCESS ROAD

The existing dirt access road is on urban/developed land. No aquatic resources are located within or adjacent to the access road. The majority of the Grays Wells Road heavy vehicle access road (Option 2) is Urban/Developed (paved road) and Urban/Developed – Dirt Road. However, a 1.43-mile segment would traverse creosote bush scrub, disturbed creosote bush scrub, and/or creosote bush-white bursage scrub. The access road would not traverse any identified state or federally protected wetlands. Therefore, the use of the access road during construction would have no impact on riparian or sensitive natural communities.

Impact 3.5-4 Interfere with Wildlife Movement

ACCESS ROAD

The existing dirt access road is on urban/developed land. The portion of Grays Wells Road that would be graded would not interfere wildlife movement. The majority of the road is a paved frontage road and is otherwise in the vicinity of other barriers to wildlife movement including canals and the I-8 Freeway. Additionally, the access road would not be fenced. Therefore, the use of the access road during construction would have no impact on wildlife movement.

Page 3.5-44

Impact 3.5-5 Conflict With Policies or Ordinances Protecting Biological Resources

CONSTRUCTION ACCESS ROAD

The use of the access road (either Gordon Wells Road access option of Grays Wells Road access option) during construction is not anticipated to result in potential impacts on biological resources because vehicles and construction equipment would be required to stay within the existing boundaries of the dirt road to avoid and/or minimize ground disturbance to undisturbed and vegetated areas. Furthermore, the project applicant would not make improvements to the existing dirt road except for the application of water for dust suppression. Based on these considerations, the use of either the access road during construction would not conflict with local policies protecting biological resources.

Page 3.5-45

Impact 3.5-6 Conflict with Habitat Conservation Plan

CONSTRUCTION ACCESS ROAD

The construction access road (either Gordon Wells Road access option of Grays Wells Road access option) is not located in a Habitat Conservation Plan, Natural Community Conservation Plan, or other approved local, regional, or state habitat conservation plan. Therefore, the use of either the access road during construction would result in no impact associated with the potential to conflict with local conservation plans.

Section 3.6 Cultural Resources

Page 3.6-16

May 5, 2023

Impact 3.6-1 Cause a substantial adverse change in the significance to a historical resource

ACCESS ROAD

During construction, vendors and heavy construction equipment would access the project site via Gordon Wells Road approximately 20 miles east of the project site, then travel west along an existing dirt road paralleling the U.S./Mexico Border. This existing dirt road is actively used by the U.S. Border Patrol during patrol operations. The use of this access road during construction is not anticipated to result in potential impacts on cultural resources because vehicles and construction equipment would be required to stay within the existing boundaries of the dirt road to avoid and/or minimize ground disturbance to undisturbed and vegetated areas. Furthermore, the project applicant would not make improvements to the existing dirt road except for the application of water for dust suppression. No grading or excavation would occur to the dirt road as a result of the project. Similarly, the Grays Wells Road heavy vehicle access option is the same route as the Gordon Wells Road access route; however, it would extend further east. A segment of this is an existing trail used by off-road vehicles; however, the majority is paved frontage road. There is a low potential that cultural resources would be identified within the area of the Grays Wells Road heavy vehicle access; and Draft EIR Cultural Resources mitigation measure CR-1 would be applicable to this proposed access route. Based on these considerations, the potential to impact cultural resources is considered low and a less than significant impact would occur.

Page 3.6-17

Impact 3.6-2 Cause a substantial adverse change in the significance of an archaeological resource

ACCESS ROAD

During construction, vendors and heavy construction equipment would access the project site via Gordon Wells Road approximately 20 miles east of the project site, then travel west along an existing dirt road paralleling the U.S./Mexico Border. This existing dirt road is actively used by the U.S. Border Patrol during patrol operations. The use of this access road during construction is not anticipated to result in potential impacts on archaeological resources because vehicles and construction equipment would be required to stay within the existing boundaries of the dirt road to avoid and/or minimize ground disturbance to undisturbed and vegetated areas. Furthermore, the project applicant would not make improvements to the existing dirt road except for the application of water for dust suppression. No grading or excavation would occur to the dirt road as a result of the project. Similarly, the Grays Wells Road heavy vehicle access option is the same route as the Gordon Wells Road access route; however, it would extend further east. A segment of this is an existing trail used by off-road vehicles; however, the majority is paved frontage road. There is a low potential that cultural resources would be identified within the area of the Grays Wells Road heavy vehicle access; and Draft EIR Cultural Resources mitigation measure CR-2 would be applicable to this proposed access route. Based on these considerations, the potential to impact archaeological resources is considered low and a less than significant impact would occur.

Page 3.6-18

Impact 3.6-3 Disturb Human Remains

ACCESS ROAD

May 5, 2023

During construction, vendors and heavy construction equipment would access the project site via Gordon Wells Road approximately 20 miles east of the project site, then travel west along an existing dirt road paralleling the U.S./Mexico Border. This existing dirt road is actively used by the U.S. Border Patrol during patrol operations. The use of this access road during construction is not anticipated to result in potential impacts on archaeological resources because vehicles and construction equipment would be required to stay within the existing boundaries of the dirt road to avoid and/or minimize ground disturbance to undisturbed and vegetated areas. Furthermore, the project applicant would not make improvements to the existing dirt road except for the application of water for dust suppression. No grading or excavation would occur to the dirt road as a result of the project. Similarly, the Grays Wells Road heavy vehicle access option is the same route as the Gordon Wells Road access route; however, it would extend further east. A segment of this is an existing trail used by off-road vehicles; however, the majority is paved frontage road. There is a low potential that cultural resources would be identified within the area of the Grays Wells Road heavy vehicle access; and Draft EIR Cultural Resources mitigation measures CR-3 would be applicable to this proposed access route. Based on these considerations, the potential to encounter human remains is considered low and a less than significant impact would occur.

Section 3.13 Transportation

Impact 3.13-4 Project Result in Inadequate Emergency Access?

Page 3.13-8

Vehicular access to the project site is currently provided via an existing driveway along SR-98. Under the proposed project, vehicular access for workers would continue to be provided via the existing driveway as the project would not require additional storage lanes or lengths along SR-98. Following discussions with the Imperial Irrigation District, it was determined heavy construction vehicles would cross the All-American Canal at Gordon Wells Road located approximately 20 miles east of the project site (**Error! Reference source not found.**). Access for heavy construction vehicles to and from the project site requires crossing the All-American Canal, via two existing bridges (**Error! Reference source not found.**), located along Gordon Wells Road. Gordon Wells Road has an interchange with I-8. The bridges over the canal were constructed in 2009. The bridges are rated as open with no restrictions and have a “Good” condition rating. The second means of access to be used for heavy truck loads would be along the border frontage road used by Home Land Security/Border Protection primarily. This road however does not connect directly to the I-8 corridor. Therefore an additional connection is required east of Gordons Well where another (paved) frontage road starts east of the All American Canal and goes east to the I – 8 rest stop, and BLM desert office. There is a gap between that frontage road and the border road that currently is a dirt trail which the proponent would improve with minimal improvements sufficient to carry large vehicles, but not be paved per request of the BLM. This proposed route is shown in Figure 2-6b.

C. CALIFORNIA ENVIRONMENTAL QUALITY ACT REQUIREMENTS AND FINDINGS SUPPORTING DECISION NOT TO RECIRCULATE

CEQA Section 15088.5(e) requires that an EIR which has been made available for public review, but not yet certified, be recirculated whenever significant new information has been added to the EIR. The entire

May 5, 2023

PC ORIGINAL PKG

document need not be recirculated, if revisions are limited to specific portions of the document. The recirculated portions or document must be sent to responsible and trustee agencies for consultation and fresh public notice must be given in the manner provided for a draft EIR. However, new information is not presumed to be significant simply because it is new. Indeed, pursuant to State CEQA Guidelines Section 15088.5:

New information added to an EIR is not "significant" unless the EIR is changed in a way that deprives the public of a meaningful opportunity to comment upon a substantial adverse environmental effect of the project or a feasible way to mitigate or avoid such an effect . . . that the project's proponents have declined to implement. State CEQA Guidelines, § 15088.5(a):

In order to be "significant," the new information requiring recirculation includes, for example, a disclosure showing that:

- (1) A new significant environmental impact would result from the project or from a new mitigation measure proposed to be implemented.
- (2) A substantial increase in the severity of an environmental impact would result unless mitigation measures are adopted that reduce the impact to a level of insignificance.
- (3) A feasible project alternative or mitigation measure considerably different from other previously analyzed would clearly lessen the environmental impacts of the project, but the project's proponent decline to adopt it.
- (4) The draft EIR was so fundamentally and basically inadequate and conclusory in nature that meaningful public review and comment were precluded. (State CEQA Guidelines, §15088.5(a)(1)-(4); *Laurel Heights II*, 6 Cal.4th at 1120.)

It is common, and in most cases necessary, to amplify and elaborate on the analysis of an EIR. CEQA anticipates this and such amplification does not constitute significant new "information" unless it triggers one of the four categories described in State CEQA Guidelines Section 15088.5(a). State CEQA Guidelines Section 15088.5(b) provides that "recirculation is not required where the new information added to the EIR merely clarifies or amplifies or makes insignificant modifications in an adequate EIR."

Based upon review of the minor corrections and additions identified in Section A above, and the additional analyses provided in Table 0.3-1, the minor corrections and additions do not result in any new or substantially increased significant impacts. Additionally, the potential second access option using Grays Wells Road would not result in any new or substantially increased significant impacts. Therefore, the County has concluded that recirculation of the Draft EIR is not required.

Discussion of Environmental Impacts

The Draft EIR for the VEGA SES 4 Solar Energy project evaluated 14 environmental impacts and issues, including: aesthetics and visual resources; agricultural resources; air quality; biological resources; cultural resources; geology and soils; greenhouse gas emissions; hazards; hydrology/water quality; land use planning; noise and vibration; transportation; tribal cultural resources; and utilities and service systems.

May 5, 2023

Table 0.3-1 lists each environmental topic evaluated in the Draft EIR and summarizes whether the proposed second heavy vehicle access option would change any impacts associated with the project. As shown, implementation of the Grays Wells Road heavy vehicle access option would not change the analysis of the Draft EIR. Furthermore, no change to the type of proposed mitigation measures would be required.

**Table 0.3-1
Summary of Environmental Impacts**

Environmental Issue Area	Summary of Potential Impact
3.2 Aesthetics and Visual Resources	No change. The addition of the Grays Wells Road heavy vehicle access option would not result in a significant visual impact. If implemented, the majority of the additional stretch of road would be located on existing paved road, and only grading of 1.43 miles of the route is required, but would remain unpaved and restored after project construction. The project, including proposed construction access roads is not located in an area subject to a designated scenic vista, is not located in proximity to a formally-designated scenic highway, and would not degrade the visual character of the area. Based on analysis contained within the Draft EIR, impacts to visual resources resulting from the implementation of the proposed project, including both construction and operation of the project, would not result in a significant impact. Use of the proposed Grays Wells Road heavy vehicle access option would not change this conclusion. Therefore, there would be no change to the Draft EIR conclusions related to aesthetics and visual resources.
3.3 Agricultural Resources	No change. Implementation of the Grays Wells Road heavy equipment access option would not impact agricultural resources. There are no agricultural lands located within the alignment of this proposed access. The project site (including proposed construction access routes) does not contain Prime Farmland, Farmland of Statewide Importance, or Unique Farmland. Therefore, the proposed project would not convert land designated as Prime Farmland, Farmland of Statewide Importance, or Unique Farmland to non-agricultural uses. The Draft EIR concludes that with implementation of Pest Management Plan (which is not applicable to the proposed construction access roads), the project’s impact to agricultural resources would be less than significant. Use of the proposed Grays Wells Road heavy vehicle access option would not change this conclusion. Therefore, there would be no change to the Draft EIR conclusions related to agricultural resources.
3.4 Air Quality	No change. The Draft EIR analysis of the proposed project concludes that with the implementation of Mitigation Measures AQ-1 through AQ-3, the proposed project would not result in short-term air quality impacts during construction. Use of either heavy equipment access Option 1 or Option 2 (i.e., via Gordon Wells Road or via Grays Wells Road) would require implementation of the same dust control measure and construction equipment emissions reduction measures as required by Mitigation Measures AQ-1 through AQ-3. The Grays Wells Road is paved, with the exception of an 1.43 mile segment that would be graded in addition to what would otherwise be required for the Gordon Wells Road option, which was evaluated in the Draft EIR. This minor increase in grading would not result in an increase in construction emissions that would exceed ICAPCD significance thresholds. As identified in Draft EIR Table 3.4-8 Project Construction-Generated Emissions – Mitigated, mitigated construction emissions are well below the threshold criteria for criteria pollutants – include PM10 and PM2.5. The use of an additional 1.43 miles

VEGA SES 4 Solar Energy Project – Errata to the Draft EIR for proposed Grays Wells Road Heavy Construction Equipment/Vehicle Access

	<p>of unpaved construction access would not significantly increase the daily emissions as the same construction vehicle equipment fleet mix would remain the same on a daily basis. Long-term (operational) use of this access would be intermittent (only as required for infrequent Therefore, there would be no change to this conclusion. Therefore, there would be no change to the Draft EIR conclusions related to air quality.</p>
3.5 Biological Resources	<p>No change. The majority of the proposed Grays Wells Road secondary on-site wireless communication facility would be located within the disturbance footprint evaluated in Section 3.4 Biological Resources of the Draft EIR. Therefore, there would be no change to the Draft EIR conclusions related to biological resources.</p>
3.6 Cultural Resources	<p>No change. The proposed Grays Wells Road option would follow the Gordon Wells Road option as evaluated in the Draft EIR. However, this option also would be located on existing paved frontage road, but would extend through an area approximately 1.43 miles in length, that is currently on off-road recreational vehicle trail. Implementation of Mitigation Measures CR-1 through CR-4 would reduce potential impacts to cultural resources to a level less than significant. These mitigation measures would be applicable to the Grays Wells Road access option, and may be further refined as part of the BLM review of the ROW application and required as part of any ROW approvals. Therefore, there would be no change to the Draft EIR conclusions related to cultural resources.</p>
3.7 Geology and Soils	<p>No change. Geotechnical conditions would not change or be affected by the Grays Wells Road heavy vehicle access option and is located in an area determined geotechnically suitable for construction of the project. There would be no permanent structures constructed for the access route. Therefore, there would be no change to the Draft EIR conclusions related to geology and soils.</p>
3.8 Greenhouse Gas Emissions	<p>No change. The Draft EIR analysis of the proposed project concludes that the proposed project would not result in short-term or long-term operational greenhouse gas (GHG) emissions impacts. The construction and use of the Grays Wells Road access alternative would require limited use of equipment, and would be the same as evaluated in the Draft EIR, which would not generate significant GHG emissions as amortized over the life of the project. Therefore, there would be no change to the Draft EIR conclusions related to greenhouse gas emissions.</p>
3.9 Hazards	<p>No change. There are no hazardous sites located within the proposed Grays Wells Road heavy vehicle access option. The use of this access would be subject to the same best management practices regarding use, storage and disposal of hazardous materials associated with construction activities as identified in the EIR, or as otherwise required by BLM as a condition of granting the required ROW. Therefore, there would be no change to the Draft EIR conclusions related to hazards.</p>
3.10 Hydrology/Water Quality	<p>No change. The proposed use of the Grays Wells Road heavy vehicle access option would be subject to same or similar drainage and stormwater quality control requirements as identified in the Draft EIR, and as may otherwise be required by BLM as a condition of the ROW approval. Therefore, there would be no change to the Draft EIR conclusions related to hydrology and water quality.</p>
3.11 Land Use Planning	<p>No change. The proposed use of the Grays Wells Road heavy vehicle access option would not change the proposed project use. The project applicant would be required to obtain ROW approvals from the BLM, which would be granted only if BLM determines the ROW request would not be in conflict with applicable plans</p>

May 5, 2023

PC ORIGINAL PKG

VEGA SES 4 Solar Energy Project – Errata to the Draft EIR for proposed Grays Wells Road Heavy Construction Equipment/Vehicle Access

	<p>under BLM's purview. Therefore, there would be no change to the Draft EIR conclusions related to land use planning.</p>
3.12 Noise and Vibration	<p>No change. The use of the Grays Wells Road heavy vehicle access option would not create a noise or vibration impact. There are no sensitive receptors located in proximity to this proposed access route. Therefore, there would be no change to the Draft EIR conclusions related to noise and vibration.</p>
3.13 Transportation	<p>No change. The use of the Grays Wells Road heavy vehicle access option would not affect traffic as this route is an off-road access route and existing and planned transportation facilities would not be affected. Therefore, there would be no change to the Draft EIR conclusions related to transportation/traffic.</p>
3.14 Tribal Cultural Resources	<p>No change. The use of the Grays Wells Road heavy vehicle access option would not affect any tribal cultural resources as none have been identified in the project area. Therefore, there would be no change to the Draft EIR conclusions related to tribal cultural resources.</p>
3.15 Utilities and Service Systems	<p>No change. The use of the Grays Wells Road heavy vehicle access option would not place a demand on utilities or service systems. Therefore, there would be no change to the Draft EIR conclusions related to utilities/service systems.</p>

May 5, 2023

PC ORIGINAL PKG

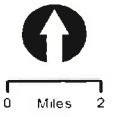
VEGA SES 4 Solar Energy Project – Errata to the Draft EIR for proposed Grays Wells Road Heavy Construction Equipment/Vehicle Access

Figure 2.6b



Legend

-  Project Location
-  Access Road Option 1
-  Access Road Option 2 (Paved)
-  Access Road Option 2 to be Graded



May 5, 2023

PC ORIGINAL PKG

RESOLUTION NO.

A RESOLUTION OF THE PLANNING COMMISSION OF THE COUNTY OF IMPERIAL, CALIFORNIA, RECOMMENDING THE IMPERIAL COUNTY BOARD OF SUPERVISORS CERTIFY THE FINAL PROJECT ENVIRONMENTAL IMPACT REPORT (EIR) FOR THE VEGA SES 4 SOLAR ENERGY PROJECT

WHEREAS, a Final Project EIR SCH #2021050018 and Candidate CEQA Findings have been prepared in accordance with the requirements of the California Environmental Quality Act, the State CEQA Guidelines, and the County's Rules to Implement CEQA as amended for the VEGA SES 4 SOLAR ENERGY Project that consists of a Water Supply Assessment, an Environmental Impact Report, a Mitigation Monitoring & Reporting Program and a Conditional Use Permit; and,

WHEREAS, the Planning Commission of the County of Imperial has been delegated with the responsibility of making recommendations to the Imperial County Board of Supervisors regarding the Project for approval and certification; and,

WHEREAS, the Final Project EIR has been provided in a timely manner to public agencies; and

WHEREAS, timely public notice of the Planning Commission's hearing on the Project application has been given, and the Planning Commission has considered evidence presented by the Imperial County Planning & Development Services Department and other interested parties at that public hearing held with respect to this item on May 24, 2023; and,

WHEREAS, the Final Project EIR includes analysis of various alternatives as required by CEQA, including the Conditional Use Permit, Mitigation Monitoring & Reporting Program and Water Supply Assessment; and,

NOW THEREFORE, the Planning Commission of the County of Imperial **DOES HEREBY RESOLVE** as follows:

SECTION 1. The Planning Commission independently has reviewed and considered the proposed Final Environmental Impact Report (FEIR), and Candidate CEQA Findings prior to making a decision to recommend that the Board of Supervisors approve the proposed FEIR and Findings of Fact. The Planning Commission finds and determines that the Environmental Impact Report is adequate and prepared in accordance with the requirements of the California Environmental Quality Act (CEQA), which analyzes environmental effects, based upon the following findings and determinations.

SECTION 2. That in accordance with, CEQA, State Planning and Zoning law and the County of Imperial Land Use Ordinance, the following findings for the recommendation for approval and certification of the FEIR and Findings of Fact have been made as follows:

1. That the Final Project EIR **SCH #2021050018** , Candidate CEQA Findings for the Vega SES Solar Energy ("Project") have been prepared in accordance with the requirements of the California Environmental Quality Act, the State CEQA Guidelines, and the County's Rules to Implement CEQA as amended, and such findings are incorporated by reference herein
2. That the County independently has reviewed, analyzed, and considered the Final Project EIR, the environmental impacts therein identified for this Project, the Candidate CEQA Findings, and the Mitigation Monitoring and Reporting Program, and the entire Record of Proceedings prior to recommending approval of this project.
3. That the Final Project EIR and the Candidate CEQA Findings reflect the independent judgment of the County.
4. That the Candidate CEQA Findings are supported by substantial evidence and backed by information provided to the County by experts, including but not limited to the County staff and the EIR preparer, on whom the County relies.
5. That the County accept as its own, incorporate as if set forth in full herein, and make each and every one of the findings contained in the Candidate CEQA Findings, including feasibility of mitigation measures pursuant to Public Resources Code 21081(a)/CEQA Guidelines 15091, and the infeasibility of project alternatives.
6. That the Project will not individually or cumulative have an unmitigated adverse effect on fish and wildlife resources, as defined in Section 711.2 of the Fish and Game Code.
7. That the Record of Proceedings consists of the Final Project EIR (and all its technical reports and addendums thereto); the County staff reports; the CEQA Findings; the Mitigation Monitoring and Reporting Program; the various Project entitlements and documents referenced therein; all final reports, applications, memoranda, maps, letters, and other planning documents prepared and/or utilized by the EIR planning/environmental consultant; all final reports, memoranda, maps, letters, and other planning documents prepared and/or utilized by the County staff; all documents submitted by members of the public and public agencies in connection with the Final Project EIR; minutes and transcripts of all public meetings and public hearings; all written and verbal public testimony presented during a noticed public hearing for the proposed project which such testimony was taken and any and all other materials which constitute the record of proceeding pursuant to Public Resources Code section 21167.6(e); and matters of common knowledge to the County staff, Planning Commission, and Board of Supervisors, including, but not limited to the County General Plan, the County Zoning Ordinance, and County policies, which may be found at the Clerk's Office located at 940 Main Street, Suite 209, El Centro, CA, 92243 during regular business hours, and the Imperial County Planning & Development Services Department at 801 Main Street, El Centro, CA 92243.
9. That the County Planning Commission does hereby recommend for the Board of Supervisors of the County of Imperial to approve of the resolution to certify the Final Project EIR (FEIR) and the Finding of Fact.

NOW, THEREFORE, based on the above findings, the Planning Commission of the County of Imperial **DOES HEREBY RECOMMEND** the Board of Supervisors approve the proposed Final EIR **SCH #2021050018**, Candidate CEQA Findings, for the VEGA SES 4 SOLAR ENERGY ("Project").

Rudy Schaffner, Chairperson
Imperial County Planning Commission

I hereby certify that the Planning Commission at a meeting conducted on **May 24, 2023** by the following vote took the preceding resolution:

AYES:

NOES:

ABSENT:

ABSTAIN:

ATTEST:

Jim Minnick, Director of Planning & Development Services
Secretary to the Planning Commission

S:\APN\059\300\015\cup20 0020\pc\reso feir.docx

**CALIFORNIA ENVIRONMENTAL QUALITY ACT FINDINGS OF FACT
(Public Resource Code §21081, CEQA Guidelines §15091)
Final Environmental Impact Report for the
VEGA SES 4 Solar Energy Project
(State Clearinghouse [SCH] No. 2021050018)**

1 Introduction

The following Findings are made for the Environmental Impact Report SCH #2021050018 (the “EIR”) for the proposed VEGA SES 4 Solar Energy Project (herein referred to as the “project”). The EIR analyzes the significant and potentially significant environmental impacts, which may occur as a result of the project.

The proposed project consists of three primary components: 1) solar energy generation equipment and associated facilities including a substation and access roads (herein referred to as “solar energy facility”); 2) battery energy storage system (BESS); and, 3) gen-tie line that would connect the proposed on-site substation to the point of interconnection at the existing Imperial Irrigation District’s (IID) 92 kilovolt (kV) “P” line. The solar energy facility, BESS, and gen-tie are collectively referred to as the “proposed project” or “project.”

The project site is located on approximately 450 acres of privately-owned land in the southernmost portion of Imperial County, California. The project site is between the U.S./Mexico international border and the All-American Canal, on the California side. It is approximately 10 miles east of the City of Calexico.

The proposed project involves the construction of a 100-megawatt (MW) alternating current (AC) photovoltaic (PV) solar energy facility with an integrated 100 MW battery storage system (not to exceed 200 MW) on approximately 450 acres of land. The project site would be developed with a ground mounted PV solar power generating system, supporting structures, on-site substation, BESS, interconnection facilities, and internal access roads. The project would employ the use of PV power systems to convert solar energy into electricity using non-reflective technology. The electrical energy produced by the project would be conducted through the project’s interconnection facilities to the proposed 92 kV gen-tie line and delivered to the existing IID approved point of interconnection on the 92 kV “P” Line.

1.1 Purpose of CEQA Findings; Terminology

CEQA Findings play an important role in the consideration of projects for which an EIR is prepared. Under Public Resources Code §21081 and CEQA Guidelines §15091 above, where a final EIR identifies one or more significant environmental effects, a project may not be approved until the public agency makes written findings supported by substantial evidence in the administrative record regarding each of the significant effects. In turn, the three possible findings specified in CEQA Guidelines §15091(a) are:

1. Changes or alterations have been required in, or incorporated into, the project, which avoid or substantially lessen the significant environmental effect as identified in the final EIR.
2. Such changes or alterations are within the responsibility and jurisdiction of another public agency and not the agency making the finding. Such changes have been adopted by such other agency or can and should be adopted by such other agency.

3. Specific economic, legal, social, technological, or other considerations, including provision of employment opportunities for highly trained workers, make infeasible the mitigation measures or project alternatives identified in the final EIR.

CEQA Guidelines §15092(b) provides that no agency shall approve a project for which an EIR was prepared unless either:

1. The project approved will not have a significant effect on the environment, or
2. The agency has:
 - a. Eliminated or substantially lessened all significant effects where feasible as shown in the findings under Section 15091, and
 - b. Determined that any remaining significant effects on the environment found to be unavoidable under Section 15091 are acceptable due to overriding concerns as described in Section 15093.

1.2 EIR Process

After the County reviewed the applications for the proposed project, it concluded that the project could have a significant impact on the environment and that preparation of an environmental impact report was determined to be the appropriate CEQA environmental document. The County issued a Notice of Preparation (NOP) on May 4, 2021 and made the NOP available for review and comment for a 35-day period closing on June 7, 2021. The NOP was distributed to city, county, and state and federal agencies, other public agencies, and various interested private organizations and individuals. The NOP was also published in the Imperial Valley Press on May 4, 2021 and in the Calexico Chronicles on May 6, 2021. A public scoping meeting was held on May 13, 2021. Four comment letters were received during the NOP review period. A copy of the NOP and written comments received in response to the NOP are included in Appendix A of the Final EIR.

Based upon comments the County received in response to the NOP, it was determined that the Draft EIR should analyze project related environmental impacts relative to the following 14 substantive potential impact areas in the Environmental Analysis section:

- Aesthetics
- Agricultural Resources
- Air Quality
- Biological Resources
- Cultural Resources
- Geology and Soils
- Greenhouse Gas Emissions
- Hazards and Hazardous Materials
- Hydrology/Water Quality
- Land Use and Planning
- Noise and Vibration

- Transportation
- Tribal Cultural Resources
- Utilities/Service Systems (Water Supply)

Additionally, the Draft EIR was required to include other CEQA substantive sections including an Executive Summary, Introduction, Environmental Setting, Project Description, Analysis of Long-Term Effects, Cumulative Impacts, Effects Found Not Significant, and Alternatives.

The Draft EIR was circulated for a statutory 45-day public review period starting on November 22, 2022 and ending on January 10, 2023 (50 actual days). One letter was received during the comment period and is responded to in the responses to comments section of the Final EIR.

2 Project Location

The project site is located on approximately 450 acres of privately-owned land in the southernmost portion of Imperial County, California. The project site is between the U.S./Mexico international border and the All-American Canal, on the California side. It is approximately 10 miles east of the City of Calexico in Sections 10, 11, 14, 15, and 16 within Township 17 South, and Range 16 East of the San Bernardino Base and Meridian of the Bonds Corner topographic 7.5-minute quadrangle. The irregular shaped project site is bound by undeveloped land, portions of which have been disturbed associated with previous agricultural-related activities to the west and east, the All-American Canal running southwest on the northern border of the project site, and the U.S./Mexico international border to the south. The project site is currently characterized by flat and undeveloped land, portions of which have been disturbed associated with previous agricultural-related activities.

3 Project Description

The proposed project consists of three primary components: 1) solar energy generation equipment and associated facilities including a substation and access roads (herein referred to as “solar energy facility”); 2) BESS; and, 3) gen-tie line that would connect the proposed on-site substation to the point of interconnection at the existing IID 92 kV “P” line.

The proposed project involves the construction and operation of a 100 MW AC PV solar energy facility with an integrated 100 MW battery storage system (not to exceed 200 MW) on approximately 450 acres of land. The project site would be developed with a ground mounted PV solar power generating system, supporting structures, on-site substation, battery storage system, interconnection facilities, and internal access roads. The project would employ the use of PV power systems to convert solar energy into electricity using non-reflective technology.

The County Land Use Ordinance, Division 17, includes the Renewable Energy (RE) Overlay Zone, which authorizes the development and operation of renewable energy projects with an approved conditional use permit (CUP). CUP applications proposed for specific renewable energy projects not located in the RE Overlay Zone would not be allowed without an amendment to the RE Overlay Zone. The entire project site is located within the RE Overlay Zone. Therefore, no General Plan Amendment or Rezone would be required to implement the proposed project.

3.1 Project Objectives

The following are the project objectives:

- Construct and operate a solar energy facility capable of producing up to 100 MW AC of electricity to assist the State of California in achieving its 60 percent renewable portfolio standard by 2030.
- Provide a 100 MW energy BESS, that would accommodate and store the power generated by the project so that the facility can continue to provide renewable energy during non-daylight hours.
- Interconnect directly to IID's existing electrical transmission system.
- Help California meet its statutory and regulatory goal of increasing renewable power generation, including greenhouse gas reduction goals of Senate Bill 32.
- Minimize and mitigate any potential impact to sensitive environmental resources within the project area.

3.2 Discretionary Actions/Approvals by the County of Imperial

The County is the "lead agency" for the proposed project. Lead agency is defined as, "the public agency, which has the principal responsibility for carrying out or approving a project." The County must undertake the following discretionary actions and approvals for the project:

1. **Approval of Conditional Use Permit.** Implementation of the project would require the approval of a conditional use permit (CUP) by the County to allow for the construction and operation of the proposed solar energy facility with an integrated BESS. The project site is located on two privately-owned legal parcels zoned Heavy Agriculture with a Renewable Energy Zone Overlay (A-3-RE). Pursuant to Title 9, Division 5, Chapter 9, the following uses are permitted in the A-3 zone subject to approval of a CUP from Imperial County:

i) Battery Storage Facility (must be connected to an existing electrical power generation plant such as solar, geothermal, wind, natural gas, or other renewable energy generator, as an accessory unit to said power plant).

oo) Major facilities relating to the generation and transmission of electrical energy, provided such facilities are not under State or Federal law, to [be] approved exclusively by an agency, or agencies of the State or Federal government, and provided such facilities shall be approved subsequent to coordination review of the Imperial Irrigation District for electrical matters, meeting the requirements in Division 17.

zz) Solar energy plants meeting the requirements in Division 17.

2. **Certification of the EIR.** After the required public review for the Draft EIR, the County will respond to written comments, edit the document, and produce a Final EIR to be certified by the Planning Commission and Board of Supervisors prior to making a decision on approval or denial of the project.

Subsequent ministerial approvals may include, but are not limited to:

- Grading and clearing permits
- Building permits
- Reclamation plan
- Encroachment permits
- Transportation permit(s)

3.3 Discretionary Actions/Approvals by Other Agencies

Responsible Agencies are those agencies that have discretionary approval over one or more actions involved with development of the project. Trustee Agencies are state agencies that have discretionary approval or jurisdiction by law over natural resources affected by a project. These agencies may include, but are not limited to the following:

- California RWQCB – Notice of Intent for General Construction Permit, CWA 401 Water Quality Certification
- ICAPCD – Fugitive Dust Control Plan, Rule 801 Compliance
- CDFW (Trustee Agency) – ESA Compliance, Section 1600 Streambed Alteration Agreement
- USFWS – ESA Compliance
- USACE – Section 404 of the CWA Permit
- IID – Water Supply Agreement
- IID - Potential Upgrades to the existing Ramon Substation

3.4 Memorandum of Understanding – U.S. Border Patrol/Department of Homeland Security

The project applicant and U.S. Border Patrol (USBP) will develop and enter into a Memorandum of Understanding (MOU) setting forth the project-related activities that may occur on an existing dirt road used by the USBP.

- Project applicant will provide an additional 60 feet of right-of-way along its southern end of the property to allow for additional protective area for the U.S. Border Patrol Services functions.
- Project applicant will install a 6-foot-high chain link fence with barb wire on top surrounding the project site.
- Project applicant will provide a mechanism acceptable to USBP for access to the site upon completion of the construction in the event USBP needs to enter for enforcement purposes.
- Project applicant will provide full-time security during construction of the project and will coordinate with USBP on this service.
- Project applicant will provide contact information for both construction phases and operation phases to make sure USBP has direct contact information.
- Project applicant will maintain the road between the site and its terminus at the I-8/HWY 98 intersection during the construction of the site in a manner prescribed by USBP. At a minimum

this will be routine watering and as necessary grading. No material will be added to the road without approval from USBP. Additionally, no work will be done adjacent to the road that would interfere with USBP's 'brushing' program.

- Project applicant will have an agreement with U.S. Bureau of Reclamation for the pedestrian traffic crossing at the IID drop and will observe USBP protocols for all people crossing for the project both during construction and future operations.
- Project applicant will notify the USBP's designated representative prior to any use of the road from Gordons Well access to the site.
- USBP will immediately contact designated project representatives if they encounter a problem at the site in an effort to give project applicant an opportunity to cure.

2.7.4 Bureau of Land Management – California Desert District U.S. Department of the Interior – Region 8 El Centro Field Office

- The project applicant will be required to obtain a Right of Way (ROW) from the Bureau of Land Management (BLM) for any heavy equipment access routes that may traverse BLM managed public lands. Should the proposed Gordon Wells Road heavy equipment access route not be utilized, a second option is proposed utilizing Grays Wells Road as described in further detail in Chapter 2 Project description.

4 Issues Addressed In the EIR

Based on the analysis presented in the NOP and the information provided in the comments to the NOP, the following environmental topics were analyzed in the EIR.

- Aesthetics
- Agriculture Resources
- Air Quality
- Biological Resources
- Cultural Resources
- Geology and Soils
- GHG Emissions
- Hazards and Hazardous Materials
- Hydrology/Water Quality
- Land Use/Planning
- Noise and Vibration
- Transportation
- Tribal Cultural Resources

- Utilities/Service Systems (Water Supply)

5 Mitigation Monitoring Program

Pursuant to PRC §21081.6, the County has adopted a detailed mitigation and monitoring program prepared under the County's direction. The program is designed to ensure that all mitigation measures as hereafter required are in fact implemented on a timely basis as the project is implemented.

6 Record of Proceedings

For all purposes of CEQA compliance, including these Findings of Fact, the administrative record of all County proceedings and decisions regarding the environmental analysis of the project include but are not limited to:

- The Draft and Final EIR for the project, together with all appendices and technical reports referred to therein, whether separately bound or not, or on a CD;
- All reports, letters, applications, memoranda, maps or other planning and engineering documents prepared by the County, its planning consultant and environmental consultant, the applicant or others and presented to or before the decision-makers or staff;
- All minutes of any public workshops, meetings or hearings, and any recorded or verbatim transcripts or videotapes thereof;
- Any letters, reports or other documents or evidence submitted into the record at any public workshops, meetings or hearings; and
- Matters of common general knowledge to the County which it may consider, including applicable state or local laws, ordinances and policies, the General Plan and all applicable planning programs and policies of the County.

Documents or other materials that constitute the record of proceedings upon which these Findings are made are located at the Department of Planning and Development Services of the County of Imperial, 801 Main Street, El Centro, CA 92243.

7 Findings of Significant Impacts, Required Mitigation Measures and Supporting Facts

The County, having reviewed and considered the information contained in the EIR and the entire administrative record, including but not limited to the expert opinions of the County's professional planning staff and independent consultants familiar with the environmental conditions of the County and the facts and circumstances of the project who prepared the EIR, finds pursuant to Public Resources Code §21081(a)(1) and Guidelines §15091(a)(1) that changes or alterations have been required in, or incorporated into, the project which would mitigate, avoid, or substantially lessen to below a level of significance the following potential significant environmental effects identified in the EIR.

7.1 Agricultural Resources

7.1.1 Involve Other Changes that Could Result in Conversion of Farmland to Non-Agricultural Use

- A. **Potential Impact.** Implementation of the project may result in changing the physical and chemical makeup of the soil materials within the upper soil horizon at the project site. Improper soil stockpiling and management of the stockpiles could result in increased decomposition of soil organic materials, increased leaching of plant available nitrogen, and depletion of soil biota communities. Any reductions in agricultural productivity could significantly limit the types of crops that may be grown within the project site in the future. Additionally, there is the potential that weeds or other pests may occur within the solar field if the area is not properly maintained and managed to control weeds and pests. The potential adverse effect on agricultural productivity is considered a significant impact under CEQA.
- B. **Finding.** Pursuant to CEQA Guidelines §15091 (a)(1), changes or alterations have been required in, or incorporated into, the project which avoid or substantially lessen the significant environmental effect as identified in the Final EIR.

Facts in Support of Finding. Based on the analysis provided in Section 3.3 of the Final EIR, the project's potentially significant impact would be mitigated to below a level of significance with the implementation of Mitigation Measures AG-1 of the Final EIR as identified below. Implementation of Mitigation Measure AG-1 would require the project applicant to prepare and submit a Pest Management Plan to the County of Imperial Agricultural Commissioner for approval. The project applicant will be required to implement the strategies contained in the Pest Management Plan until reclamation is complete on the project site. Additionally, as a condition of project approval (CUP condition), the project applicant or its successor in interest will be responsible for implementing a reclamation plan when the project is decommissioned at the end of its lifespan.

Mitigation Measure AG-1 - Pest Management Plan. Prior to the issuance of a grading permit or building permit (whichever occurs first), a Pest Management Plan shall be developed by the project applicant and approved by the County of Imperial Agricultural Commissioner. The project applicant shall maintain a Pest Management Plan until reclamation is complete. The plan shall provide the following:

1. Monitoring, preventative, and management strategies for weed and pest control during construction activities at any portion of the project (e.g., transmission line);
2. Control and management of weeds and pests in areas temporarily disturbed during construction where native seed will aid in site revegetation as follows:
 - Monitor for all pests including insects, vertebrates, weeds, and pathogens. Promptly control or eradicate pests when found, or when notified by the Agricultural Commissioner's office that a pest problem is present on the project site. The assistance of a licensed pest control advisor is recommended. All treatments must be performed by a qualified applicator or a licensed pest control business;

- All treatments must be performed by a qualified applicator or a licensed pest control operator;
 - “Control” means to reduce the population of common pests below economically damaging levels, and includes attempts to exclude pests before infestation, and effective control methods after infestation. Effective control methods may include physical/mechanical removal, bio control, cultural control, or chemical treatments;
 - Use of “permanent” soil sterilants to control weeds or other pests is prohibited because this would interfere with reclamation;
 - Notify the Agricultural Commissioner’s office immediately regarding any suspected exotic/invasive pest species as defined by the California Department of Food Agriculture and the U.S. Department of Agriculture. Request a sample be taken by the Agricultural Commissioner’s Office of a suspected invasive species. Eradication of exotic pests shall be done under the direction of the Agricultural Commissioner’s Office and/or California Department of Food and Agriculture;
 - Obey all pesticide use laws, regulations, and permit conditions;
 - Allow access by Agricultural Commissioner staff for routine visual and trap pest surveys, compliance inspections, eradication of exotic pests, and other official duties;
 - Ensure all project employees that handle pest control issues are appropriately trained and certified, all required records are maintained and made available for inspection, and all required permits and other required legal documents are current;
 - Maintain records of pests found and treatments or pest management methods used. Records should include the date, location/block, project name (current and previous if changed), and methods used. For pesticides include the chemical(s) used, EPA Registration numbers, application rates, etc. A pesticide use report may be used for this;
 - Submit a report of monitoring, pest finds, and treatments, or other pest management methods to the Agricultural Commissioner quarterly within 15 days after the end of the previous quarter, and upon request. The report is required even if no pests were found or treatment occurred. It may consist of a copy of all records for the previous quarter or may be a summary letter/report as long as the original detailed records are available upon request.
2. A long-term strategy for weed and pest control and management during the operation of the proposed project. Such strategies may include, but are not limited to:
- Use of specific types of herbicides and pesticides on a scheduled basis.
3. Maintenance and management of project site conditions to reduce the potential for a significant increase in pest-related nuisance conditions on surrounding agricultural lands.

4. The project shall reimburse the Agricultural Commissioner's office for the actual cost of investigations, inspections, or other required non-routine responses to the site that are not funded by other sources.

7.2 Air Quality

7.2.1 Air Quality Emissions - Construction

- A. **Potential Impact.** As shown in Final EIR Table 3.4-7, the project's daily construction emissions would not exceed the ICAPCD thresholds for ROG, NO_x, CO, SO₂, and PM_{2.5}. However, the project would exceed the ICAPCD threshold for PM₁₀ and is considered a significant impact.
- B. **Finding.** Pursuant to CEQA Guidelines §15091 (a)(1), changes or alterations have been required in, or incorporated into, the project which avoid or substantially lessen the significant environmental effect as identified in the Final EIR.
- C. **Facts in Support of Finding.** Pursuant to the Imperial County Air Pollution Control District (ICAPCD), all construction sites, regardless of size, must comply with the requirements contained within Regulation VIII – Fugitive Dust Control Measures. The project must comply with the requirements of ICAPCD Regulation VIII for the control of fugitive dust. A predominate source of project PM₁₀ emissions is workers commuting to and from the project site on unpaved roads (worker access and heavy construction equipment access routes described above). Regulation VIII requires all unpaved roadways, on- and off-site, to be conditioned and maintained with soil stabilizers to reduce dust opacity to no more than 20 percent; all unpaved disturbed surfaces, on- and off-site, to be stabilized with a dust suppressant, watering, or soil stabilizers to reduce opacity to no greater than 20 percent; and to reduce vehicle speed to no greater than 15 mph on all unpaved surfaces. Final EIR Table 3.4-8 shows the project's emissions with implementation of the Regulation VIII fugitive dust control measures (Mitigation Measure AQ-1). With implementation of Mitigation Measure AQ-1, the project would not exceed the ICAPCD's thresholds of significance for PM₁₀ emissions.

In addition, as described in Mitigation Measure AQ-2, construction equipment shall be equipped with an engine designation of EPA Tier 2 or better (Tier 2+). A list of the construction equipment, including all off-road equipment utilized at the project site by make, model, year, horsepower and expected/actual hours of use, and the associated EPA Tier shall be submitted to the County Planning and Development Services Department and ICAPCD prior to the issuance of a grading permit. The equipment list shall be submitted periodically to ICAPCD to perform a NO_x analysis. ICAPCD shall utilize this list to calculate air emissions to verify that equipment use does not exceed significance thresholds.

Mitigation Measure AQ-1 - Fugitive Dust Control. During construction activities, the constructor contractor shall employ the following PM₁₀ reducing measures:

1. All unpaved roads associated with construction shall be effectively stabilized of dust emissions using Imperial County Air Pollution Control District-approved chemical stabilizers/suppressant before the commencement of construction, and

every 30 days thereafter until the end of all construction activities. Unpaved roads associated with construction include:

- The driveway entrance off State Route 98,
- The project designated 3.5-acre staging/parking area north of the All-American Canal,
- The 1.0 mile of dirt road south of the All-American Canal,
- The 20 miles of existing dirt road paralleling the U.S./Mexico Border from Gordon Wells Road to the project site.

Monthly application of Imperial County Air Pollution Control District-approved chemical stabilizers/suppressant shall be applied at a rate of 0.1 gallon/ square yard of chemical dust suppressant.

2. Prior to any earthmoving activity, the applicant shall submit a construction dust control plan and obtain Imperial County Air Pollution Control District and Imperial County Planning and Development Services Department (ICPDS) approval.
3. Pursuant to ICAPCD, all construction sites, regardless of size, must comply with the requirements contained within Regulation VIII – Fugitive Dust Control Measures. Whereas these Regulation VIII measures are mandatory and are not considered project environmental mitigation measures, the ICAPCD CEQA Handbook's required additional standard and enhanced mitigation measures listed below shall be implemented prior to and during construction. ICAPCD will verify implementation and compliance with these measures as part of the grading permit review/approval process.

ICAPCD Standard Measures for Fugitive Dust (PM₁₀) Control

- All disturbed areas, including bulk material storage, which is not being actively utilized, shall be effectively stabilized and visible emissions shall be limited to no greater than 20 percent opacity for dust emissions by using water, chemical stabilizers, dust suppressants, tarps, or other suitable material, such as vegetative ground cover.
- All on-site and off-site unpaved roads will be effectively stabilized, and visible emissions shall be limited to no greater than 20 percent opacity for dust emissions by paving, chemical stabilizers, dust suppressants, and/or watering.
- All unpaved traffic areas 1 acre or more with 75 or more average vehicle trips per day will be effectively stabilized and visible emissions shall be limited to no greater than 20 percent opacity for dust emissions by paving, chemical stabilizers, dust suppressants, and/or watering.
- The transport of bulk materials shall be completely covered unless 6 inches of freeboard space from the top of the container is maintained with no spillage and loss of bulk material. In addition, the cargo compartment of all haul trucks is to be cleaned and/or washed at delivery site after removal of bulk material.

- All track-out or carry-out will be cleaned at the end of each workday or immediately when mud or dirt extends a cumulative distance of 50 linear feet or more onto a paved road within an urban area.
- Movement of bulk material handling or transfer shall be stabilized prior to handling or at points of transfer with application of sufficient water, chemical stabilizers, or by sheltering or enclosing the operation and transfer line.
- The construction of any new unpaved road is prohibited within any area with a population of 500 or more unless the road meets the definition of a temporary unpaved road. Any temporary unpaved road shall be effectively stabilized, and visible emissions shall be limited to no greater than 20 percent opacity for dust emission by paving, chemical stabilizers, dust suppressants, and/or watering.

ICAPCD “Discretionary” Measures for Fugitive Dust (PM₁₀) Control

- Water exposed soil only in those areas where active grading and vehicle movement occurs with adequate frequency to control dust.
- Replace ground cover in disturbed areas as quickly as possible.
- Automatic sprinkler system installed on all soil piles.
- Vehicle speed for all construction vehicles shall not exceed 15 miles per hour on any unpaved surface at the construction site.
- Develop a trip reduction plan to achieve a 1.5 average vehicle ridership for construction employees.
- Implement a shuttle service to and from retail services and food establishments during lunch hours.

Standard Mitigation Measures for Construction Combustion Equipment

- Use of alternative fueled or catalyst equipped diesel construction equipment, including all off-road and portable diesel-powered equipment.
- Minimize idling time either by shutting equipment off when not in use or reducing the time of idling to 5 minutes as a maximum.
- Limit, to the extent feasible, the hours of operation of heavy-duty equipment and/or the amount of equipment in use.
- Replace fossil fueled equipment with electrically driven equivalents (provided they are not run via a portable generator set).

Enhanced Mitigation Measures for Construction Equipment

To help provide a greater degree of reduction of PM emissions from construction combustion equipment, ICAPCD recommends the following enhanced measures.

- Curtail construction during periods of high ambient pollutant concentrations; this may include ceasing of construction activity during the peak hour of vehicular traffic on adjacent roadways.
- Implement activity management (e.g., rescheduling activities to reduce short-term impacts).

Mitigation Measure AQ-2 - Construction Equipment. Construction equipment shall be equipped with an engine designation of EPA Tier 2 or better (Tier 2+). A list of the construction equipment, including all off-road equipment utilized at the project site by make, model, year, horsepower and expected/actual hours of use, and the associated EPA Tier shall be submitted to the County Planning and Development Services Department and ICAPCD prior to the issuance of a grading permit. The equipment list shall be submitted periodically to ICAPCD to perform a NO_x analysis. ICAPCD shall utilize this list to calculate air emissions to verify that equipment use does not exceed significance thresholds. The Planning and Development Services Department and ICAPCD shall verify implementation of this measure.

7.2.2 Air Quality Emissions - Operation

- A. **Potential Impact.** The proposed project requires minimal operations and maintenance activities conducted by two to three employees. Long-term operational emissions attributable to the project are identified in Final EIR Table 3.4-9 and compared to the operational significance thresholds promulgated by the ICAPCD. As shown in Final EIR Table 3.4-9, the project's operational emissions would not exceed the ICAPCD thresholds for CO, ROG, NO_x, PM₁₀ and PM_{2.5}. Although no significant air quality impact would occur during operation, the project applicant is required to submit a Dust Suppression Management Plan for both construction and operation in order to reduce fugitive dust emissions. Implementation of Mitigation Measures AQ-1, AQ-3 and AQ-4 would ensure that a Dust Suppression Management Plan is implemented, thereby ensuring that this potential impact would remain less than significant.
- B. **Finding.** Pursuant to CEQA Guidelines §15091 (a)(1), changes or alterations have been required in, or incorporated into, the project which avoid or substantially lessen the significant environmental effect as identified in the Final EIR.
- C. **Facts in Support of Finding.** Based on the analysis provided in Section 3.4 of the Final EIR, no significant air quality impact would occur during operation. Although no significant air quality impact would occur during operation, the project applicant is required to submit a Dust Suppression Management Plan for both construction and operation in order to reduce fugitive dust emissions. Implementation of Mitigation Measures AQ-1, AQ-3 and AQ-4 would ensure that a Dust Suppression Management Plan is implemented, thereby ensuring that this potential impact would remain less than significant.

Mitigation Measure AQ-1 - Fugitive Dust Control (as described above)

Mitigation Measure AQ-3 - Dust Suppression. The project applicant shall employ a method of dust suppression (such as water or chemical stabilization) approved by ICAPCD. The project applicant shall apply chemical stabilization as directed by the product manufacturer to control dust between the panels as approved by ICAPCD, and other non-used areas (exceptions will be the paved entrance and parking area, and Fire Department access/emergency entry/exit points as approved by Fire/Office of Emergency Services [OES] Department).

Mitigation Measure AQ-4 - Operational Dust Control Plan. Prior to issuance of a Certificate of Occupancy, the applicant shall submit an operations dust control plan and obtain ICAPCD and ICPDS approval.

ICAPCD Rule 301 Operational Fees apply to any project applying for a building permit. At the time that building permits are submitted for the proposed project, ICAPCD shall review the project to determine if Rule 310 fees are applicable to the project.

7.3 Biological Resources

7.3.1 Special-Status Plant Species

- A. **Potential Impact.** There is moderate potential for three rare plant species, Abram's spurge, Wiggins' croton, and sand food, to be present within the project area. Suitable habitat for these species is present within the creosote bush scrub and disturbed creosote bush – white bursage scrub habitats. Impacts that may occur to the species during project construction includes loss of individuals, habitat, and seedbank. Depending on the size of the population, potential impacts could be significant.
- B. **Finding.** Pursuant to CEQA Guidelines §15091 (a)(1), changes or alterations have been required in, or incorporated into, the project which avoid or substantially lessen the significant environmental effect as identified in the Final EIR.
- C. **Facts in Support of Finding.** Based on the analysis provided in Section 3.5 of the Final EIR, the project's potential impacts on special-status plant species would be mitigated to below a level of significance with implementation of Mitigation Measures BIO-1 through BIO-3 of the Final EIR. Mitigation Measure BIO-1 requires the project applicant to conduct rare plant surveys prior to initiating ground disturbance.

Mitigation Measure BIO-2 requires implementation of general impact avoidance and minimization measures during construction such as designating a Project Biologist to oversee compliance with protective measures for biological resources, delineating construction zones, and working and traveling only in designated work areas and access roads. Mitigation Measure BIO-3 requires all construction personnel to complete a Worker Environmental Awareness Program prior to the start of construction.

Mitigation Measure BIO-1 - Rare Plant Surveys. Prior to initiating ground disturbance, rare plant surveys shall be conducted within suitable habitat on the project site during the appropriate blooming period for the Abrams' spurge (approximately September through November), Wiggins' croton (approximately March through May), and sand food (approximately April through June). The surveys shall be conducted by a botanist or qualified biologist in accordance with the USFWS Guidelines for Conducting and Reporting Botanical Inventories for Federally Listed, Proposed, and Candidate Plants (USFWS 1996); the CDFW Protocols for Surveying and Evaluating Impacts to Special Status Native Plant Populations and Sensitive Natural Communities (CDFW 2018); and the CNPS Botanical Survey Guidelines (CNPS 2001). If any special-status species are observed during the rare plant surveys, the location of the individual plant or population will be recorded with a submeter GPS device for mapping purposes. If project-related impacts to rare plants on the project site are unavoidable,

then consultation with CDFW may be required to develop a mitigation plan or additional avoidance and minimization measures. Mitigation measures that may be implemented if the species is observed include establishing a no-disturbance buffer around locations of individuals or a population, salvage or seed collection, and additional monitoring requirements.

Mitigation Measure BIO-2 - General Impact Avoidance and Minimization Measures. The following measures will be applicable throughout the life of the project:

- To reduce the potential indirect impact on migratory birds, bats and raptors, the project will comply with the APLIC 2012 Guidelines for overhead utilities, as appropriate, to minimize avian collisions with transmission facilities (APLIC 2012)
- All electrical components on the project site shall be either undergrounded or protected so that there will be no exposure to wildlife and therefore no potential for electrocution.
- The project proponent shall designate a Project Biologist who shall be responsible for overseeing compliance with protective measures for the biological resources during vegetation clearing and work activities within and adjacent to areas of native habitat. The Project Biologist will be familiar with the local habitats, plants, and wildlife. The Project Biologist will also maintain communications with the Contractor to ensure that issues relating to biological resources are appropriately and lawfully managed and monitor construction. The Project Biologist will monitor activities within construction areas during critical times, such as vegetation removal, the implementation of Best Management Practices (BMP), and installation of security fencing to protect native species. The Project Biologist will ensure that all wildlife and regulatory agency permit requirements, conservation measures, and general avoidance and minimization measures are properly implemented and followed.
- The boundaries of all areas to be newly disturbed (including solar facility areas, staging areas, access roads, and sites for temporary placement of construction materials and spoils) will be delineated with stakes and flagging prior to disturbance. All disturbances, vehicles, and equipment will be confined to the flagged areas.
- No potential wildlife entrapments (e.g., trenches, bores) will be left uncovered overnight. Any uncovered pitfalls will be excavated to 3:1 slopes at the ends to provide wildlife escape ramps. Alternatively, man-made ramps may be installed. Covered pitfalls will be covered completely to prevent access by small mammals or reptiles.
- To avoid wildlife entrapment (including birds), all pipes or other construction materials or supplies will be covered or capped in storage or laydown area, and at the end of each workday in construction, quarrying and processing/handling areas. No pipes or tubing of sizes or inside diameters ranging from 1 to 10 inches will be left open either temporarily or permanently.

- No anticoagulant rodenticides, such as Warfarin and related compounds (indandiones and hydroxycoumarins), may be used within the project site, on off-site project facilities and activities, or in support of any other project activities.
- Avoid wildlife attractants. All trash and food-related waste shall be placed in self-closing containers and removed regularly from the site to prevent overflow. Workers shall not feed wildlife. Water applied to dirt roads and construction areas for dust abatement shall use the minimal amount needed to meet safety and air quality standards to prevent the formation of puddles, which could attract wildlife. Pooled rainwater or floodwater within retention basins will be removed to avoid attracting wildlife to the active work areas.
- To minimize the likelihood for vehicle strikes on wildlife, speed limits will not exceed 15 miles per hour when driving on access roads. All vehicles required for O&M must remain on designated access/maintenance roads.
- Avoid night-time construction lighting or if nighttime construction cannot be avoided use shielded directional lighting pointed downward and towards the interior of the project site, thereby avoiding illumination of adjacent natural areas and the night sky.
- All construction equipment used for the Project will be equipped with properly operating and maintained mufflers.
- Hazardous materials and equipment stored overnight, including small amounts of fuel to refuel hand-held equipment, will be stored within secondary containment when within 50 feet of open water to the fullest extent practicable. Secondary containment will consist of a ring of sandbags around each piece of stored equipment/structure. A plastic tarp/Visqueen lining with no seams shall be placed under the equipment and over the edges of the sandbags, or a plastic hazardous materials secondary containment unit shall be utilized by the Contractor.
- The Contractor will be required to conduct vehicle refueling in upland areas where fuel cannot enter waters of the U.S. and in areas that do not have potential to support federally threatened or endangered species. Any fuel containers, repair materials, including creosote-treated wood, and/or stockpiled material that is left on site overnight, will be secured in secondary containment within the work area and staging/assembly area and covered with plastic at the end of each work day.
- In the event that no activity is to occur in the work area for the weekend and/or a period of time greater than 48 hours, the Contractor will ensure that all portable fuel containers are removed from the project site.
- All equipment will be maintained in accordance with manufacturer's recommendations and requirements.
- Equipment and containers will be inspected daily for leaks. Should a leak occur, contaminated soils and surfaces will be cleaned up and disposed of following the guidelines identified in the Stormwater Pollution Prevention Plan or equivalent, Materials Safety Data Sheets, and any specifications required by other permits issued for the project.

- The Contractor will utilize off-site maintenance and repair shops as much as possible for maintenance and repair of equipment.
- If maintenance of equipment must occur onsite, fuel/oil pans, absorbent pads, or appropriate containment will be used to capture spills/leaks within all areas. Where feasible, maintenance of equipment will occur in upland areas where fuel cannot enter waters of the U.S. and in areas that do not have potential to support federally threatened or endangered species.
- Appropriate BMPs will be used by the Contractor to control erosion and sedimentation and to capture debris and contaminants from bridge construction to prevent their deposition in waterways. No sediment or debris will be allowed to enter the creek or other drainages. All debris from construction of the bridge will be contained so that it does not fall into channel. Appropriate BMPs will be used by the Contractor during construction to limit the spread of resuspended sediment and to contain debris.
- Erosion and sediment control devices used for the proposed project, including fiber rolls and bonded fiber matrix, will be made from biodegradable materials such as jute, with no plastic mesh, to avoid creating a wildlife entanglement hazard.
- Firearms, open fires, and pets would be prohibited at all work locations and access roads. Smoking would be prohibited along the Project alignment.
- Cross-country vehicle and equipment use outside of approved designated work areas and access roads shall be prohibited to prevent unnecessary ground and vegetation disturbance.
- Any injured or dead wildlife encountered during project-related activities shall be reported to the project biologist, biological monitor, CDFW, or a CDFW-approved veterinary facility as soon as possible to report the observation and determine the best course of action. For special-status species, the Project Biologist shall notify the County, USFWS, and/or CDFW, as appropriate, within 24 hours of the discovery.
- Stockpiling of material will be allowed only within established work areas.
- Actively manage the spread of noxious weeds
- The ground beneath all parked equipment and vehicles shall be inspected for wildlife before moving.

Mitigation Measure BIO-3 - Worker Environmental Awareness Program. Prior to project construction, a Worker Environmental Awareness Program shall be developed and implemented by a qualified biologist and shall be available in both English and Spanish. Handouts summarizing potential impacts to special-status biological resources and the potential penalties for impacts to these resources shall be provided to all construction personnel. At a minimum, the education program shall include the following:

- The purpose for resource protection;

- A description of special-status species including representative photographs and general ecology;
- Occurrences of USACE, RWQCB, and CDFW regulated features in the Project study area;
- Regulatory framework for biological resource protection and consequences if violated
- Sensitivity of the species to human activities;
- Avoidance and minimization measures designed to reduce the impacts to special-status biological resources;
- Environmentally responsible construction practices;
- Reporting requirements;
- The protocol to resolve conflicts that may arise at any time during the construction process; and
- Workers sign acknowledgement form indicating that the Environmental Awareness Training and Education Program that has been completed and would be kept on record.

7.3.2 Special-Status Wildlife Species

- A. **Potential Impact.** Five special-status wildlife species were observed on site during the habitat assessment: black-tailed gnatcatcher, northern harrier, burrowing owl, yellow warblers, and loggerhead shrikes were observed in the tamarisk thickets in the western portion of the project site. Burrowing owl and their burrows were observed within the disturbed creosote-white bursage scrub in the western portion of the project site, within a berm adjacent to the access road, and in a concrete pile in the northeastern corner of the site. Direct construction-related impacts to wildlife species that could occur include injury, mortality, nest failures, and loss of young. Indirect impacts include increase in anthropogenic effects (i.e., noise levels, introduction of invasive/nonnative species, increase in human activity, and increase in dust.

Northern harriers are ground nesters; therefore, the tamarisk thicket and disturbed arrow weed thicket habitats provide potential nesting habitat for this species. Direct impacts to nesting avian species include injury, mortality, loss of young, and nest failure. Indirect impacts include loss of foraging and nesting habitat for passerine and raptors species, increase in noise and human activities, and potential introduction of invasive/nonnative species.

The use of this access road during construction is not anticipated to result in potential impacts on biological resources, with the exception of roosting bats, if present. Bat acoustic surveys and monitoring should be implemented to determine if sensitive bat species occur within the Gordon Road Wells bridge or palm trees (if planned for removal). All bat species with potential for occurrence for the project are SSC species and potential project-related impacts to bat species and bat maternity roosts are considered significant.

- B. **Finding.** Pursuant to CEQA Guidelines §15091 (a)(1), changes or alterations have been required in, or incorporated into, the project which avoid or substantially lessen the significant environmental effect as identified in the Final EIR.
- C. **Facts in Support of Finding.** Based on the analysis provided in Section 3.5 of the Final EIR, the project's potential impacts on special-status wildlife species would be mitigated to below a level of significance with implementation of Mitigation Measures BIO-2 through BIO-7 of the Final EIR. Mitigation Measure BIO-2 requires implementation of general impact avoidance and minimization measures during construction such as designating a Project Biologist to oversee compliance with protective measures for biological resources, delineating construction zones, and working and traveling only in designated work areas and access roads. Mitigation Measure BIO-3 requires all construction personnel to complete a Worker Environmental Awareness Program prior to the start of construction.

Mitigation Measure BIO-4 requires pre-construction surveys for burrowing owl. If burrowing owl is identified during the breeding season (February 1 through August 31), then an appropriate buffer will be established by the biological monitor in accordance with the *Staff Report on Burrowing Owl Mitigation* (CDFG 2012). Construction within the buffer will be avoided until a qualified biologist determines that burrowing owl is no longer present or until young have fledged. Mitigation Measure BIO-5 requires a pre-construction nesting bird survey to be conducted by a qualified avian biologist to ensure that active bird nests, including those for the black-tailed gnatcatcher, northern harrier, yellow warbler, burrowing owl, and loggerhead strike will not be disturbed or destroyed. Mitigation Measure BIO-6 requires a pre-construction survey to be conducted for special-status wildlife species within all areas of potential permanent and temporary disturbance. Mitigation Measure BIO-7 requires a qualified bat biologist to conduct an appropriate combination of sampling, exit counts, and acoustic surveys to determine if bats are using the palm tree resources in the project area.

Mitigation Measure BIO-2 - General Impact Avoidance and Minimization Measures (as described above)

Mitigation Measure BIO-3 - Worker Environmental Awareness Program (as described above)

Mitigation Measure BIO-4 - Burrowing Owl Avoidance and Minimization. Take Avoidance (pre-construction) surveys for burrowing owl shall be completed prior to project construction. Surveys shall be conducted as detailed within Appendix E of the *Staff Report on Burrowing Owl Mitigation* (California Department of Fish and Game [CDFG] 2012). If burrowing owl is not detected, construction may proceed.

- If burrowing owl is identified during the non-breeding season (September 1 through January 31), then a 50-meter buffer will be established by the biological monitor. Construction within the buffer will be avoided until a qualified biologist determines that burrowing owl is no longer present or until a CDFW-approved exclusion plan has been implemented. The buffer distance may be reduced if noise attenuation buffers such as hay bales are placed between the occupied burrow and construction activities.

- If burrowing owl is identified during the breeding season (February 1 through August 31), then an appropriate buffer will be established by the biological monitor in accordance with the *Staff Report on Burrowing Owl Mitigation* (CDFG 2012). Construction within the buffer will be avoided until a qualified biologist determines that burrowing owl is no longer present or until young have fledged. The buffer distance may be reduced in consultation with CDFW if noise attenuation buffers such as hay bales are placed between the occupied burrow and construction activities.

Mitigation Measure BIO-5 - Pre-Construction Nesting Bird Survey. If construction or other project activities are scheduled to occur during the bird breeding season (typically February 1 through August 31 for raptors and March 15 through August 31 for the majority of migratory bird species), a pre-construction nesting-bird survey shall be conducted by a qualified avian biologist to ensure that active bird nests, including those for the black-tailed gnatcatcher, northern harrier, yellow warbler, burrowing owl, and loggerhead strike, will not be disturbed or destroyed. The survey shall be completed no more than three days prior to initial ground disturbance. The nesting-bird survey shall include the project site and adjacent areas where project activities have the potential to affect active nests, either directly or indirectly due to construction activity or noise. If an active nest is identified, the biologist shall establish an appropriately sized disturbance-limit buffer around the nest using flagging or staking. Construction activities shall not occur within any disturbance-limit buffer zones until the nest is deemed inactive by the qualified biologist. If construction activities cease for a period of greater than three days during the bird breeding season, a pre-construction nesting bird survey shall be conducted prior to the commencement of activities. Final construction buffers or setback distances shall be determined by the qualified biologist in coordination with USFWS and CDFW on a case-by-case basis, depending on the species, season in which disturbance shall occur, the type of disturbance, and other factors that could influence susceptibility to disturbance (topography, vegetation, existing disturbance levels, etc.).

Mitigation Measure BIO-6 - Pre-Construction Survey for Special-Status Species. A pre-construction survey shall be conducted for special-status wildlife species within all areas of potential permanent and temporary disturbance. The pre-construction survey shall take place no more than 14 days prior to the start of ground-disturbing activities. The pre-construction surveys should take place regardless of breeding season timing and shall focus on identifying the presence of special-status wildlife species present on the project site or that were identified as having a high potential to occur on the site. These species include, but are not limited to, flat-tailed horned lizard, burrowing owl, northern harrier, black-tailed gnatcatcher, and yellow warbler. Should any special-status species be identified during the pre-construction survey, consultation to develop suitable avoidance and minimization measures with the appropriate agency (USFWS, CDFW) may need to be undertaken.

Mitigation Measure BIO-7 - Bat Acoustic Surveys and Monitoring. To avoid impacts to bat species, a qualified bat biologist shall conduct an appropriate combination of sampling, exit counts, and acoustic surveys to determine if bats are using the palm tree resources in the project area. If project-related impacts to bat

species are unavoidable, additional measures may need to be implemented to reduce or eliminate impacts to bat species, including maternity roosts, such as tree removal occurring outside of bat breeding season (October through February) or two-step, two-day removal of palm trees under supervision of a qualified bat biologist.

7.4 Cultural Resources

7.4.1 Historical Resources

- A. **Potential Impact.** Five cultural resources are being treated as eligible for listing in the California Register of Historical Resources as historical resources under CEQA. The proposed project has been designed to avoid Sites 2020-142-001, 2020-142-002, 2020-142-004, 2020-142-005, and 2020-142-008. The project applicant will avoid ground-disturbing activities within and in close proximity to these resources. However, if-ground disturbing activities must occur within and in close proximity to these resources, a significant impact may potentially occur.
- B. **Finding.** Pursuant to CEQA Guidelines §15091 (a)(1), changes or alterations have been required in, or incorporated into, the project which avoid or substantially lessen the significant environmental effect as identified in the Final EIR.
- C. **Facts in Support of Finding.** Based on the analysis provided in Section 3.6 of the Final EIR, the project's potentially significant impact would be mitigated to below a level of significance with implementation of Mitigation Measures CR-1 and CR-2 of the Final EIR. Mitigation Measure CR-1 requires the area within 100 feet of Sites 2020-142-001, 2020-142-002, 2020-142-004, 2020-142-005, and 2020-142-008 to be designated Environmentally Sensitive Area (ESA) and fenced or flagged with exclusion markers to ensure avoidance. Mitigation Measure CR-2 requires all work to be halted within a 100-foot radius in the event cultural resources are discovered during construction. Work may not resume within the no-work radius until the Imperial County Planning and Development Services Department, through consultation as appropriate, determine that the site either: 1) is not an Historical Resource under CEQA or an Historic Property under Section 106; or 2) that the treatment measures have been completed to their satisfaction.

Mitigation Measure CR-1 - Environmentally Sensitive Area Fencing. Prior to issuance of grading permits and in coordination with a qualified archaeologist to be retained by the project applicant, the construction zone shall be narrowed or otherwise altered to avoid Sites 2020-142-001, 2020-142-002, 2020-142-004, 2020-142-005, and 2020-142-008. The area within 100 feet of Sites 2020-142-001, 2020-142-002, 2020-142-004, 2020-142-005, and 2020-142-008 shall be designated Environmentally Sensitive Area (ESA) and fenced or flagged with exclusion markers to ensure avoidance. Protective fencing shall not identify the protected area as a cultural resource area in order to discourage unauthorized disturbance or collection of artifacts. The ESA fencing or flags shall remain in place throughout project construction.

Mitigation Measure CR-2 - Evaluate Significance of Find (Unknown Cultural Resources). If subsurface deposits believed to be cultural in origin are discovered during construction, all work must halt within a 100-foot radius of the discovery. A qualified professional archaeologist who meets the Secretary of the Interior's

Standards for prehistoric and historic archaeology and is familiar with the resources of the region, shall be retained to evaluate the significance of the find, and shall have the authority to modify the no work radius as appropriate, using professional judgment. The following notifications shall apply, depending on the nature of the find:

- If the professional archaeologist determines that the find does not represent a cultural resource, work may resume immediately, and no agency notifications are required.
- If the professional archaeologist determines that the find does represent a cultural resource from any time period or cultural affiliation, he or she shall immediately notify the Imperial County Planning and Development Services Department. The Imperial County Planning and Development Services Department shall consult with the professional archaeologist on a finding of eligibility and implement appropriate treatment measures if the find is determined to be an Historical Resource under CEQA, as defined in Section 15064.5(a) of the CEQA Guidelines, or an Historic Property, as defined in 36 CFR 60.4. Work may not resume within the no-work radius until the Imperial County Planning and Development Services Department, through consultation as appropriate, determine that the site either: 1) is not an Historical Resource under CEQA or an Historic Property under Section 106; or 2) that the treatment measures have been completed to their satisfaction.

7.4.2 Archaeological Resources

- A. **Potential Impact.** The potential of finding a buried archaeological site during construction is considered low. However, like all construction projects in the state, the possibility exists. This potential impact is considered significant.
- B. **Finding.** Pursuant to CEQA Guidelines §15091 (a)(1), changes or alterations have been required in, or incorporated into, the project which avoid or substantially lessen the significant environmental effect as identified in the Final EIR.

Facts in Support of Finding. Based on the analysis provided in Section 3.6 of the Final EIR, the project's potentially significant impact would be mitigated to below a level of significance with implementation of Mitigation Measure CR-3. Mitigation Measure CR-3 requires the contractor to cease all work activities within approximately 100 feet of the discovery. In the event of an unanticipated discovery of archaeological materials during construction, the applicant shall retain the services of a qualified professional archaeologist to evaluate the significance of the materials prior to resuming any construction-related activities in the vicinity of the find. If the qualified archaeologist determines that the discovery constitutes a significant resource under CEQA and it cannot be avoided, the applicant shall implement an archaeological data recovery program.

Mitigation Measure CR-3 - Evaluate Significance of Find (Unknown Archaeological Resources). In the event of the discovery of previously unidentified archaeological materials, the contractor shall immediately cease all work activities within approximately 100 feet of the discovery. After cessation of excavation, the contractor shall immediately contact the Imperial County Department of Planning and Development Services Department. Except in the case of cultural items that fall within the scope of the Native American Grave Protection and Repatriation Act, the

discovery of any cultural resource within the project area shall not be grounds for a “stop work” notice or otherwise interfere with the project’s continuation except as set forth in this paragraph.

In the event of an unanticipated discovery of archaeological materials during construction, the applicant shall retain the services of a qualified professional archaeologist, meeting the Secretary of the Interior’s Standards for a Qualified Archaeologist, to evaluate the significance of the materials prior to resuming any construction-related activities in the vicinity of the find. If the qualified archaeologist determines that the discovery constitutes a significant resource under CEQA and it cannot be avoided, the applicant shall implement an archaeological data recovery program.

7.4.3 Human Remains

- A. **Potential Impact.** During the construction and operational phases of the proposed project, grading, excavation and trenching will be required. Although the potential for encountering subsurface human remains within the project site is low, there remains a possibility that human remains are present beneath the ground surface, and that such remains could be exposed during project construction. The potential to encounter human remains is considered a significant impact.
- B. **Finding.** Pursuant to CEQA Guidelines §15091 (a)(1), changes or alterations have been required in, or incorporated into, the project which avoid or substantially lessen the significant environmental effect as identified in the Final EIR.
- C. **Facts in Support of Finding.** Based on the analysis provided in Section 3.6 of the Final EIR, the project’s potential impact to human remains would be mitigated to below a level of significance with implementation of Mitigation Measure CR-4, provided below from the Final EIR. This measure requires that construction be halted in the area where the remains are found and the procedures set forth in California Health and Safety Code 7050.5, CEQA Section 15064.5, and California Public Resources Code Section 5097.98 (NPS 1983), as applicable.

Mitigation Measure CR-4 - Human Remains. If subsurface deposits believed to be human in origin are discovered during construction, all work must halt within a 100-foot radius of the discovery. A qualified professional archaeologist who meets the Secretary of the Interior’s Standards for prehistoric and historic archaeology and is familiar with the resources of the region, shall be retained to evaluate the significance of the find, and shall have the authority to modify the no work radius as appropriate, using professional judgment. The following notifications shall apply, depending on the nature of the find:

- If the find includes human remains, or remains that are potentially human, the professional archaeologist shall ensure reasonable protection measures are taken to protect the discovery from disturbance (AB 2641). The archaeologist shall notify the Imperial County Coroner (per § 7050.5 of the Health and Safety Code). The provisions of § 7050.5 of the California Health and Safety Code, § 5097.98 of the California PRC, and AB 2641 will be implemented.

- If the Coroner determines the remains are Native American and not the result of a crime scene, the Coroner will notify the NAHC, which then will designate a Native American Most Likely Descendant (MLD) for the project (§ 5097.98 of the PRC). The designated MLD will have 48 hours from the time access to the property is granted to make recommendations concerning treatment of the remains. If the landowner does not agree with the recommendations of the MLD, the NAHC may mediate (§ 5097.94 of the PRC). If no agreement is reached, the landowner must rebury the remains where they will not be further disturbed (§ 5097.98 of the PRC). This will also include either recording the site with the NAHC or the appropriate Information Center; using an open space or conservation zoning designation or easement; or recording a reinternment document with the county in which the property is located (AB 2641). Work may not resume within the no-work radius until the Imperial County Planning and Development Services Department, through consultation as appropriate, determine that the treatment measures have been completed to their satisfaction.

7.5 Geology and Soils

7.5.1 Seismic Ground Shaking

- Potential Impact.** Even with the integration of building standards, ground shaking within the project site could cause some structural damage to the facility structures or, at least, cause unsecured objects to fall. During a stronger seismic event, ground shaking could expose employees to injury from structural damage or collapse of electrical distribution facilities. Given the potentially hazardous nature of the project facilities, the potential impact of ground motion during an earthquake is considered a significant impact, as proposed structures, such as the substation and transmission lines could be damaged.
- Finding.** Pursuant to CEQA Guidelines §15091 (a)(1), changes or alterations have been required in, or incorporated into, the project which avoid or substantially lessen the significant environmental effect as identified in the Final EIR.
- Facts in Support of Finding.** Based on the analysis provided in Section 3.7 of the Final EIR, the project's potential impact would be mitigated to below a level of significance with implementation of Mitigation Measure GEO-1 of the Final EIR. This measure includes preparing geotechnical reports and implementing required measures.

Mitigation Measure GEO-1 - Prepare Geotechnical Report(s) as Part of Final Engineering for the Project and Implement Required Measures. Facility design for all project components shall comply with the site-specific design recommendations as provided by a licensed geotechnical or civil engineer to be retained by the project applicant. The final geotechnical and/or civil engineering report shall address and make recommendations on the following:

- Site preparation
- Soil bearing capacity

- Appropriate sources and types of fill
- Potential need for soil amendments
- Structural foundations
- Grading practices
- Soil corrosion of concrete and steel
- Erosion/winterization
- Seismic ground shaking
- Liquefaction
- Expansive/unstable soils

In addition to the recommendations for the conditions listed above, the geotechnical investigation shall include subsurface testing of soil and groundwater conditions, and shall determine appropriate foundation designs that are consistent with the version of the CBC that is applicable at the time building and grading permits are applied for. All recommendations contained in the final geotechnical engineering report shall be implemented by the project applicant. The final geotechnical and/or civil engineering report shall be submitted to Imperial County Public Works Department, Engineering Division for review and approval prior to issuance of building permits.

7.5.2 Liquefaction

- A. **Potential Impact.** The project site has not been mapped for liquefaction potential by CGS (Appendix G of the Final EIR). However, given that the project site is underlain by sand and clay, there is a potential for liquefaction to occur on the project site. Additional geotechnical investigation would be required in order to assess the risk of liquefaction on the project site. The potential impact on liquefaction is considered a significant impact.
- B. **Finding.** Pursuant to CEQA Guidelines §15091 (a)(1), changes or alterations have been required in, or incorporated into, the project which avoid or substantially lessen the significant environmental effect as identified in the Final EIR.
- C. **Facts in Support of Finding.** Based on the analysis provided in Section 3.7 of the Final EIR, the project's potential impact would be mitigated to below a level of significance with implementation of Mitigation Measure GEO-1. This measure includes preparing geotechnical reports and implementing recommendations made by a licensed geotechnical engineer in compliance with the CBC prepared as part of a formal geotechnical investigation.

Mitigation Measure GEO-1 (as described above).

7.5.3 Construction Related Erosion

- A. **Potential Impact.** During the site grading and construction phases, large areas of unvegetated soil would be exposed to erosive forces by water or wind for extended periods of time. Unvegetated soils are much more likely to erode from precipitation than vegetated areas because plants act to disperse, infiltrate, and retain water.

Construction activities involving soil disturbance, excavation, cutting/filling, stockpiling, and grading activities could result in increased erosion and sedimentation to surface waters. Construction could produce sediment-laden stormwater runoff (nonpoint source pollution), a major contributor to the degradation of water quality. If precautions are not taken to contain contaminants, construction-related erosion impacts are considered significant.

- B. **Finding.** Pursuant to CEQA Guidelines §15091 (a)(1), changes or alterations have been required in, or incorporated into, the project which avoid or substantially lessen the significant environmental effect as identified in the Final EIR.
- C. **Facts in Support of Finding.** Based on the analysis provided in Section 3.7 of the Final EIR, the project's potential impact would be mitigated to below a level of significance with implementation of Mitigation Measure GEO-1, and Mitigation Measure HYD-1 of the Final EIR (refer to Final EIR Section 3.10 Hydrology/Water Quality). Mitigation Measure HYD-1 requires that soil stabilization and erosion control practices (e.g., hydroseeding, erosion control blankets, mulching) are implemented during the construction phase.

7.5.4 Unstable Geologic Unit or Soil

- A. **Potential Impact.** The potential for lateral spreading to occur on the project site has not yet been determined. Additional geotechnical investigation would be required in order to assess the risk of lateral spreading to occur on the project site. The potential impact associated with lateral spreading is considered a significant impact.

As described above, given that the project site is underlain by sand and clay, there is potential for liquefaction to occur on the project site. Additional geotechnical investigation would be required in order to assess the risk of liquefaction on the project site. The potential impact on liquefaction is considered a significant impact.

It is unknown whether collapsible soils are present on the project site. Additional geotechnical investigation would be required in order to assess the risk of collapsible soils to occur on the project site. The potential impact associated with collapsible soils is considered a significant impact.

- B. **Finding.** Pursuant to CEQA Guidelines §15091 (a)(1), changes or alterations have been required in, or incorporated into, the project which avoid or substantially lessen the significant environmental effect as identified in the Final EIR.
- C. **Facts in Support of Finding.** Based on the analysis provided in Section 3.7 of the Final EIR, the project's potential impacts would be mitigated to below a level of significance with implementation of Mitigation Measure GEO-1. This measure includes preparing geotechnical reports and implementing recommendations made by a licensed geotechnical engineer in compliance with the CBC prepared as part of a formal geotechnical investigation.

Mitigation Measure GEO-1 (as described above).

7.5.5 Expansive or Corrosive Soils

- A. **Potential Impact.** The project site is underlain by sand, gravelly sand and clay/silty clay. Generally, sands are not considered expansive soils. However, clays may exhibit moderate to high expansion potential due to variation in moisture content. Unless properly mitigated, shrink-swell soils could exert additional pressure on buried structures and electrical connections producing shrinkage cracks that could allow water infiltration and compromise the integrity of backfill material. These conditions could be worsened if structural facilities are constructed directly on expansive soil materials. This potential impact would be significant as structures could be damaged by these types of soils. In addition, corrosive soils can damage underground utilities including pipelines and cables, or weaken roadway structures. This potential impact would be significant as structures could be damaged by these types of soils.
- B. **Finding.** Pursuant to CEQA Guidelines §15091 (a)(1), changes or alterations have been required in, or incorporated into, the project which avoid or substantially lessen the significant environmental effect as identified in the Final EIR.
- C. **Facts in Support of Finding.** Based on the analysis provided in Section 3.7 of the Final EIR, the project's potential impact would be mitigated to below a level of significance with implementation of Mitigation Measure GEO-1. A site-specific geotechnical investigation would be required at the project site to determine the extent and effect of problematic soils which have been identified during preliminary laboratory screenings of near surface on-site soils. Implementation of Mitigation Measure GEO-1, which requires the preparation of a design-level geotechnical report, would reduce potential impacts associated with expansive and corrosive soils to a level less than significant.

Mitigation Measure GEO-1 (as described above).

7.5.6 Paleontological Resources

- A. **Potential Impact.** The project site is in the Salton Basin near the shoreline of ancient Lake Cahuilla. The lake covered much of the Imperial Valley and created an extensive lacustrine environment. Lake Cahuilla experienced several fill recession episodes before it finally dried up about 300 years ago. In 1905, the Colorado River overflowed into the Salton Basin creating the present-day Salton Sea. As previously mentioned above, the project site is generally underlain by deposits from periodic flooding of the Colorado River and Lake Cahuilla. Therefore, the project site is considered to be paleontologically sensitive. Project construction has the potential to unearth and/or potentially destroy previously undiscovered paleontological resources.
- B. **Finding.** Pursuant to CEQA Guidelines §15091 (a)(1), changes or alterations have been required in, or incorporated into, the project which avoid or substantially lessen the significant environmental effect as identified in the Final EIR.
- C. **Facts in Support of Finding.** Based on the analysis provided in Section 3.7 of the Final EIR, Mitigation Measures GEO-2 would reduce the potential impact on paleontological resources to a level less than significant. Mitigation Measure GEO-2 would require that in the event where paleontological resources are discovered, construction shall be halted within 50 feet of any paleontological finds and shall not

resume until a Qualified Paleontologist can determine the significance of the find and/or the find has been fully investigated, documented, and cleared.

Mitigation Measure GEO-2 Paleontological Resources. In the event that unanticipated paleontological resources or unique geologic resources are encountered during ground-disturbing activities, work must cease within 50 feet of the discovery and a paleontologist shall be hired to assess the scientific significance of the find. The consulting paleontologist shall have knowledge of local paleontology and the minimum levels of experience and expertise as defined by the *Society of Vertebrate Paleontology's Standard Procedures (2010) for the Assessment and Mitigation of Adverse Impacts to Paleontological Resources*. If any paleontological resources or unique geologic features are found within the project site, the consulting paleontologist shall prepare a paleontological Treatment and Monitoring Plan to include the methods that will be used to protect paleontological resources that may exist within the project site, as well as procedures for monitoring, fossil preparation and identification, curation of specimens into an accredited repository, and preparation of a report at the conclusion of the monitoring program.

7.6 Hydrology and Water Quality

7.6.1 Violation of Water Quality Standards during Construction

- A. **Potential Impact.** During the construction phase, sedimentation and erosion can occur because of tracking from earthmoving equipment, erosion and subsequent runoff of soil, and improperly designed stockpiles. In addition to erosion and sedimentation, many different types of hazardous compounds will be used during the construction phase, with proper application, management, and containment being of high importance. Poorly managed construction materials can lead to the possibility for exposure of potential contaminants to precipitation. When this occurs, these visible and/or non-visible constituents become entrained in storm water runoff. This is considered a potentially significant impact.
- B. **Finding.** Pursuant to CEQA Guidelines §15091 (a)(1), changes or alterations have been required in, or incorporated into, the project which avoid or substantially lessen the significant environmental effect as identified in the Final EIR.
- C. **Facts in Support of Finding.** Based on the analysis provided in Section 3.10 of the Final EIR, the project's potentially significant impact would be mitigated to below a level of significance with implementation of Mitigation Measures HYD-1 of the Final EIR. Prior to construction and grading activities, the project applicant is required to file a Notice of Intent (NOI) with the State Water Resources Control Board to comply with the General National Pollution Discharge Elimination System (NPDES) Construction Permit and prepare a Stormwater Pollution Prevention Plan (SWPPP), which addresses the measures that would be included during construction or the project to minimize and control construction and post-construction runoff to the maximum extent practicable. In addition, NPDES permits require the implementation of BMPs that achieve a level of pollution control to the maximum extent practical. With the implementation of Mitigation Measure HYD-1, impacts on surface water quality as attributable to the project would be reduced to a less than significant level through the

inclusion of focused BMPs for the protection of surface water resources. Monitoring and contingency response measures would be included to verify compliance with water quality objectives for all surface waters crossed during construction. In addition, given that site decommissioning would result in similar activities as identified for construction, these impacts could also occur in the future during site restoration activities.

Mitigation Measure HYD-1 - Prepare SWPPP and Implement BMPs Prior to Construction and Site Restoration. The project applicant or its contractor shall prepare a SWPPP specific to the project and be responsible for securing coverage under SWRCB's NPDES stormwater permit for general construction activity (Order 2009-0009-DWQ). The SWPPP shall identify specific actions and BMPs relating to the prevention of stormwater pollution from project-related construction sources by identifying a practical sequence for site restoration, BMP implementation, contingency measures, responsible parties, and agency contacts. The SWPPP shall reflect localized surface hydrological conditions and shall be reviewed and approved by the appropriate agency prior to commencement of work and shall be made conditions of the contract with the contractor selected to build and decommission the project. The SWPPP shall incorporate control measures in the following categories:

- Soil stabilization and erosion control practices (e.g., hydroseeding, erosion control blankets, mulching)
- Sediment control practices (e.g., temporary sediment basins, fiber rolls)
- Temporary and post-construction on- and off-site runoff controls
- Special considerations and BMPs for water crossings and drainages
- Monitoring protocols for discharge(s) and receiving waters, with emphasis place on the following water quality objectives: dissolved oxygen, floating material, oil and grease, potential of hydrogen (pH), and turbidity
- Waste management, handling, and disposal control practices
- Corrective action and spill contingency measures
- Agency and responsible party contact information
- Training procedures that shall be used to ensure that workers are aware of permit requirements and proper installation methods for BMPs specified in the SWPPP

The SWPPP shall be prepared by a Qualified SWPPP Practitioner and/or Qualified SWPPP Developer with BMPs selected to achieve maximum pollutant removal and that represent the best available technology that is economically achievable. Emphasis for BMPs shall be placed on controlling discharges of oxygen-depleting substances, floating material, oil and grease, acidic or caustic substances or compounds, and turbidity. BMPs for soil stabilization and erosion control practices and sediment control practices will also be required. Performance and effectiveness of these BMPs shall be determined either by visual means where applicable (i.e., observation of above-normal sediment release), or by actual water sampling in cases where verification of contaminant reduction or elimination, (inadvertent petroleum release) is required to determine adequacy of the measure.

7.6.2 Violation of Water Quality Standards during Operation

- A. **Potential Impact.** As runoff flows over developed surfaces, water can entrain a variety of potential pollutants including, but not limited to, oil and grease, pesticides, trace metals, and nutrients. These pollutants can become suspended in runoff and carried to receiving waters. These effects are commonly referred to as non-point source water quality impacts.

Long-term operation of the solar facility poses a limited threat to surface water quality after the completion of construction. The project would be subject to the County's Grading Regulations as specified in Section 91010.02 of the Ordinance Code. However, since the project site is located in unincorporated Imperial County and not subject to a Municipal Separate Storm Sewer System or NPDES General Industrial Permit, there is no regulatory mechanism in place to address post-construction water quality concerns. Based on this consideration, the project has the potential to result in both direct and indirect water quality impacts that could be significant.

- B. **Finding.** Pursuant to CEQA Guidelines §15091 (a)(1), changes or alterations have been required in, or incorporated into, the project which avoid or substantially lessen the significant environmental effect as identified in the Final EIR.

- C. **Facts in Support of Findings.** Based on the analysis provided in Section 3.10 of the Final EIR, the project's potentially significant impact would be mitigated to below a level of significance with implementation of Mitigation Measure HYD-2 of the Final EIR. Mitigation Measure HYD-2 requires the project to incorporate post-construction source control and treatment control BMPs into the project's final drainage plan.

Mitigation Measure HYD-2 - Incorporate Post-Construction Runoff, Source Control, and Treatment Control BMPs into Final Project Drainage Plan. The project's Final Drainage Plan shall adhere to the County's Engineering Guidelines Manual, IID "Draft" Hydrology Manual, or other recognized source with approval by the County Engineer to control and manage the on- and off-site discharge of stormwater to existing drainage systems. The Final Drainage Plan shall provide both short- and long-term drainage solutions to ensure the proper sequencing of drainage facilities, and shall include source control and treatment BMPs to adequately treat collected runoff prior to discharge, as necessary.

8 Cumulative Impacts

As analyzed in Chapter 5 of the Final EIR, cumulative impacts to agricultural resources, air quality, biological resources, cultural resources, geology and soils, and hydrology/water quality would be significant prior to implementation of project specific mitigation measures, and mitigation that would be required of other cumulative projects.

Agricultural Resources

As discussed in Section 3.3, Agricultural Resources, the project does not contain Prime Farmland, Farmland of Statewide Importance, or Unique Farmland. Therefore, the proposed project would not convert land designated as Prime Farmland, Farmland of Statewide Importance, or Unique Farmland to non-agricultural uses or incrementally add to the conversion of agricultural land in Imperial County

on a temporary or permanent basis. Furthermore, the project site is located within the Renewable Energy Zone and is, therefore, considered an appropriate use in this area. Additionally, as a condition of project approval (CUP condition), the project applicant or its successor in interest will be responsible for implementing a reclamation plan when the project is decommissioned at the end of its lifespan.

A portion of the project site is designated as Farmland of Local Importance. It should be noted that analysis of Other Land and Farmland of Local Importance is not required under CEQA significance criteria, as these designations are not considered an “agricultural land” per CEQA Statute Section 21060.1(a). However, in terms of preservation of agricultural land Mitigation Measure AG-1 would be implemented to reduce potential impacts related to pests to a less than significant level. Each individual cumulative project would be or would have been required to provide mitigation for any impacts on agricultural resources in accordance with the County’s policies directed at mitigating the impact associated with the conversion of important farmlands. Therefore, the project’s contribution to this impact would be less than cumulatively considerable.

Air Quality

Construction. The proposed project would generate air emissions due to vehicle and dust emissions associated with construction activities. Similar effects would also be realized upon site decommissioning, which would be carried out in conjunction with the project’s restoration plan, and subject to applicable ICAPCD standards. Likewise, the other cumulative projects identified in Final EIR Table 5-1 would result in the generation of air emissions during construction activities.

With respect to the proposed project, during the construction and decommissioning phases, the project would generate ROG, NO_x, CO, SO₂, PM₁₀, and PM_{2.5} emissions during each active day of construction. As discussed in Section 3.4, Air Quality, the project’s daily construction emissions would not exceed the ICAPCD thresholds for ROG, NO_x, CO, SO₂, and PM_{2.5}. However, the project would exceed the ICAPCD threshold for PM₁₀ and represents a significant air quality impact. The project’s impact could be cumulatively considerable because the Imperial County portion of the SSAB are nonattainment already for O₃ and PM₁₀ under state standards and for O₃ and PM_{2.5} federal standards. Thus, existing O₃ and PM₁₀ levels in the SSAB are at unhealthy levels during certain periods. Additionally, the cumulative construction effects could again be experienced in the future during decommissioning and site restoration activities.

Several of the projects listed in Final EIR Table 5-1 are already constructed and in operation. Furthermore, the remaining cumulative projects, with exception of the Vikings Solar, Iris Cluster – Lyons, and Centinela Solar Projects, are currently under construction and not anticipated to involve overlapping construction activities with the proposed project. In the event the proposed project is constructed in conjunction with the Vikings Solar Project (pending entitlement), Iris Cluster – Lyons (approved but not built), and Centinela Solar Project (approved but not built), each project would be subject to mitigation pursuant to ICAPCD’s Regulations. Therefore, the cumulative impact would be reduced to a level less than significant through compliance with these measures. Further, because the proposed project will be required to implement measures consistent with ICAPCD regulations designed to alleviate the cumulative impact associated with fugitive dust (PM₁₀) and NO_x, the project’s contribution would be rendered less than cumulatively considerable and is therefore, less than significant.

Operation. As the proposed project would have no major stationary emission sources and would require minimal vehicular trips, operation of the proposed solar facility would result in substantially lower emissions than project construction. The project’s operational emissions would not exceed the

Tier I thresholds; therefore, the impact would be less than significant. Operational impacts of other renewable energy facilities identified in Final EIR Table 5-1 would also be similar. Although these cumulative projects generally involve large areas, their operational requirements are very minimal, requiring minimal staff or use of machinery or equipment that generate emissions. Further, alternative energy projects, such as the project, would assist attainment of regional air quality standards and improvement of regional air quality by providing clean, renewable energy sources. Consequently, the projects would provide a positive contribution to the implementation of applicable air quality plan policies and compliance with EO S-3-05.

However, from a cumulative air quality standpoint, the potential cumulative impact associated with the generation of O₃, PM_{2.5} and PM₁₀ emissions during operation of the cumulative projects is a consideration because existing O₃ and PM₁₀ levels in the SSAB are at unhealthy levels during certain periods. Imperial County is classified as non-attainment for PM_{2.5} for the urban areas of Imperial County. However, the project's operational contribution to O₃, PM_{2.5} and PM₁₀ would be below a level of significance. As with the construction phases, the cumulative projects would be required to comply with ICAPCD's Regulation VIII for dust control (Regulation VIII applies to both the construction and operational phases of projects). As a result, the ICAPCD would be required to comply with the various dust control measures and to prepare and implement operational dust control plans as approved by the ICAPCD, which is a component of ICAPCD's overall framework of the AQAP that sets forth a comprehensive program for SSAB's compliance with all federal and state air quality standards. Therefore, the project would not contribute to long-term cumulatively considerable air quality impacts and the project would not result in cumulatively significant air quality impacts, and cumulative impacts would be less than significant.

Biological Resources

The geographic scope for considering cumulative impacts on biological resources includes the Imperial Valley and related biological habitats. Final EIR Table 5-1 lists the projects considered for the biological resources cumulative impact analysis.

In general terms, in instances where a potential impact could occur, CDFW and USFWS have promulgated a regulatory scheme that limits impacts on these species. The effects of the project would be rendered less than significant through implementation of Mitigation Measures BIO-1 to BIO-7 (Section 3.5, Biological Resources) which require compliance with all applicable regulations that protect plant, fish, and animal species. Other cumulative projects would also be required to avoid impacts on special-status species and/or mitigate to the satisfaction of the CDFW and USFWS for the potential loss of habitat. As described in Section 3.5, Biological Resources, the project has the potential to result in impacts on biological resources. These impacts are generally focused on potential construction-related effects to special-status plant species and wildlife.

The proposed project has been designed to avoid impacts to the riparian habitat, disturbed riparian habitat, and tamarisk thickets (CDFW sensitive natural community) within the project site. However, 14 special-status plant species that have the potential to occur within the project site. 11 of these plant species have a low potential to occur due to limited suitable habitat. Due to the presence of suitable habitat and several known recent occurrences within five miles of the project site, the following species were determined to have moderate potential to occur: Abram's spurge (CRPR 2B.2), Wiggins' croton (CRPR 2B.2), and sand food (CRPR 1B.2). Implementation of Mitigation Measures BIO-1, BIO-2, and BIO-3 would reduce project impacts to a level less than significant.

Burrowing Owls are protected by the CDFW mitigation guidelines for burrowing owl (CDFW 2012) and Consortium guidance (1993), which require a suite of mitigation measures to ensure direct effects to burrowing owls during construction activities are avoided and indirect effects through burrow destruction and loss of foraging habitat are mitigated at prescribed ratios. Additionally, as provided in Section 3.5, Biological Resources, special-status bird species have a potential to be present. In addition, several common bird species could nest on the project site. As a result of project-related construction activities, one or more of these protected species could be harmed. However, with the implementation of Mitigation Measures BIO-2 through BIO-7, as identified in Section 3.5, Biological Resources, these impacts would be reduced to a level of less than significant.

As with the proposed project, the cumulative projects within the geographic scope of the project would be required to comply with the legal framework and provide mitigation for impacts on biological resources as described above. Based on these considerations, impacts on biological resources would not be cumulatively considerable.

The analysis below is conducted qualitatively and in the context that the cumulative projects would be subject to a variety of statutes and administrative frameworks that require mitigation for impacts on biological resources.

Birds listed at 50 CFR 10.3 are protected by the MBTA (16 USC 703 et seq.), a Federal statute that implements treaties with several countries on the conservation and protection of Birds listed at 50 CFR 10.3 are protected by the MBTA (16 USC 703 et seq.), a Federal statute that implements treaties with several countries on the conservation and protection of migratory birds. The MBTA is enforced by USFWS. This act prohibits the killing of any migratory birds without a valid permit. Any activity which contributes to unnatural migratory bird mortality could be prosecuted under this act. With few exceptions, most birds are considered migratory under this act. Raptors and active raptor nests are protected under California FGCs 3503.5, 3503, and 3513.

The CWA and California's Porter-Cologne Water Quality Control Act provide protection for water-related biological resources by controlling pollution, setting water quality standards, and preventing jurisdictional streams, lakes, and rivers from being filled without a federal permit. Freshwater forested/shrub wetland are present within the project site. Additionally, perennial and ephemeral drainage features are also present and convey flows in the wetlands within and around the All-American Canal. As such, these drainage features would likely be considered federally and state jurisdictional. However, the proposed project has been designed to avoid impacts to aquatic resources. As shown on the Site Plan (Figure 2-3), project components would not be sited on the project site where aquatic resources are present. Therefore, implementation of the project would result in no impact on state or federally protected aquatic resources.

The proposed project would comply with these and other laws, regulations and guidelines and therefore would not contribute substantially to a cumulative biological resources impact. Similarly, the cumulative projects within the geographic scope of the proposed project will be required to comply with the legal frameworks set forth above, as well as others, and will be required to mitigate their impacts to a less than significant level. Therefore, the project would not contribute to a cumulatively considerable impact to biological resources, and cumulative impacts would be less than significant.

Cultural Resources

As discussed in Section 3.6, Cultural Resources, five cultural resources are being treated as eligible for listing in the CRHR as historical resources. However, the project has been designed to avoid all five historical resources and Mitigation Measure CR-1 will be implemented to ensure the sites are

avoided during construction. Mitigation Measure CR-1 requires the installation of orange environmentally sensitive area fencing or flagging around the boundaries of each of the resources prior to any construction activity and shall remain in place throughout project construction. Further, in the event that unknown cultural resources are discovered during project construction, significant impacts could occur. Therefore, Mitigation Measure CR-2 would be implemented to reduce potential impacts to previously unrecorded cultural resources to a level less than significant.

The potential of finding a buried archaeological site during construction is considered low. However, like all construction projects in the state, the possibility exists. This potential impact is considered significant. Implementation of Mitigation Measure CR-3 would reduce potential impacts associated with the unanticipated discovery of unknown buried archaeological resources. Additionally, implementation of Mitigation Measure CR-4 would reduce potential impacts on human remains to a level less than significant.

Future projects with potentially significant impacts on cultural resources would be required to comply with federal, state, and local regulations and ordinances protecting cultural resources through implementation of similar project-specific mitigation measures during construction. Therefore, through compliance with regulatory requirements, standard conditions of approval, and Mitigation Measures CR-1 through CR-4, the proposed project would have a less than cumulatively considerable contribution to impacts on cultural resources.

During operations and decommissioning of the project, no additional impacts on archeological resources would be anticipated because the soil disturbance would have already occurred and been mitigated during construction.

Geology and Soils

The Imperial Valley portion of the Salton Trough physiographic province of Southern California is used as the geographic scope for the analysis of cumulative impacts on geology/soils and mineral resources. Cumulative development would result in an increase in population and development that could be exposed to hazardous geological conditions, depending on the location of proposed developments. Geologic and soil conditions are typically site specific and can be addressed through appropriate engineering practices. Cumulative impacts on geologic resources would be considered significant if the project would be impacted by geologic hazard(s) and if the impact could combine with off-site geologic hazards to be cumulatively considerable. None of the projects identified within the geographic scope of potential cumulative impacts would intersect or be compounded with the project's site-specific geology and soils impacts which would be addressed by a site-specific geotechnical report per Mitigation Measure GEO-1. Therefore, no cumulatively considerable effects are identified for geology/soils, and cumulative impacts would be less than significant.

Development of the proposed project, in combination with other projects in the area, has the potential to contribute to a cumulatively significant paleontological resources impact due to the potential loss of paleontological resources unique to the region. However, mitigation is included in this EIR to reduce potentially significant project impacts to paleontological resources during construction of the proposed project. Implementation of Mitigation Measure GEO-2 would ensure that the potential impacts on paleontological resources do not rise to the level of significance. Future projects with potentially significant impacts on paleontological resources would be required to comply with federal, state, and local regulations and ordinances protecting paleontological resources through implementation of similar project-specific mitigation measures during construction. Therefore, through compliance with regulatory requirements, standard conditions of approval, and Mitigation Measure GEO-2, the

proposed project would have a less than cumulatively considerable contribution to impacts on paleontological resources.

Hydrology/Water Quality

Final EIR Table 5-1 lists the projects considered for the hydrology and water quality cumulative impact analysis. The geographic scope for considering cumulative hydrology and water quality impacts is the Imperial Valley Hydrologic Unit as defined by the Colorado Basin RWQCB Basin Plan.

The construction of the project is expected to result in short-term water quality impacts. Compliance with the SWRCB's NPDES general permit for activities associated with construction (2009-0009-DWQ) per Mitigation Measure HYD-1 would reduce water quality impacts. As with the project, future cumulative projects would be required to comply with the Construction General Permit. The SWRCB has determined that the Construction General Permit protects water quality, is consistent with the CWA, and addresses the cumulative impacts of numerous construction activities throughout the state. This determination in conjunction with the implementation of mitigation would ensure short-term water quality impacts are not cumulatively considerable.

The project is not expected to result in long-term operations-related impacts related to water quality. The project would mitigate potential water quality impacts by preparing a drainage plan that would implement site design, source control, and treatment control BMPs per Mitigation Measure HYD-2. Future cumulative projects may also be required to comply with the SWRCB's NPDES general permit for industrial activities, as well as rules found in the CWA, Section 402(p)(1) and 40 CFR 122.26, and implemented Order No. 90-42 of the RWQCB. With implementation of SWRCB, Colorado River RWQCB, and County policies, plans, and ordinances governing land use activities that may degrade or contribute to the violation of water quality standards, cumulatively considerable impacts on water quality would be minimized to a less than significant level.

Based on a review of the FEMA Flood Insurance Rate Map FIRM, the proposed solar energy facility, gen-tie line, and access roads located on the western portion of the project site are located in Zone X (unshaded). The FEMA Zone X (unshaded) designation is an area determined to be outside the 0.2 percent annual chance floodplain. As such, the project would not result in a significant cumulatively considerable impact on floodplains by constructing new facilities within an identified flood hazard zone.

Based on these considerations, the project would not contribute to or result in a significant cumulatively considerable impact to hydrology or water quality, and cumulative impacts would be less than significant.

9 Effects Found Not to Be Significant

CEQA Guidelines §15128 require that an EIR contain a brief statement disclosing the reasons why various possible significant effects of the project were found not to be significant, and therefore would not be discussed in detail in the EIR. Final EIR Chapter 6 identifies the following issues areas that will not be impacted by the project: Forestry Resources, Energy, Mineral Resources, Population and Housing, Public Services, Recreation, Utilities and Service Systems (wastewater, stormwater, power, natural gas, and telecommunications, and solid waste), and Wildfire.

10 Findings Regarding Feasible Alternatives

Pursuant to CEQA Guidelines §15126.6(a), EIRs must “describe a range of reasonable alternatives to the project, or to the location of this project, which would feasibly attain most of the basic objectives of the project but would avoid or substantially lessen any of the significant effects of the project, and evaluate the comparative merits of the alternatives.”

CEQA establishes no categorical legal imperative as to the scope of alternatives to be analyzed in an EIR. To be legally sufficient, the consideration of project alternatives in an EIR must permit informed agency decision-making and informed public participation. The analysis of alternatives is evaluated against a rule of reason. Alternatives are suitable for study in an EIR if they meet all of the following thresholds: (1) substantially reduce or avoid the project’s significant environmental impacts; (2) attain most of the basic project objectives; (3) are potentially feasible; and (4) are reasonable and realistic. (Guidelines §15126.6, Subds. (a), (c).) Candidate alternatives that do not satisfy these requirements may be excluded from further analysis. An EIR need not consider alternatives that would change the fundamental nature of the project or that cannot achieve the fundamental goals and purposes of the proposed project.

The alternatives to the project are evaluated in Section 7 of the EIR in terms of their ability to meet the basic objectives of the project, and eliminate or further reduce its significant environmental effects. Based on these parameters, the following alternatives were considered and analyzed in the EIR:

- (1) Alternative 1–No Project/No Development Alternative
- (2) Alternative 2–Reduced Project Site

10.1 Alternative 1 – No Project/No Development

The State CEQA Guidelines require analysis of the No Project Alternative. According to §15126.6(e)(1) “[t]he specific alternative of ‘no project’ shall also be evaluated along with its impact.” Additionally, according to CEQA Guidelines §15126.6(3)(2), the ‘no project’ analysis shall discuss the existing conditions at the time the notice of preparation is published, or if no notice of preparation is published, at the time environmental analysis is commenced, as well as what would be reasonably expected to occur in the foreseeable future if the project were not approved, based on the current plans and consistent with available infrastructure and community services.

Because the solar energy facility would not be constructed on the proposed project site, the Alternative 1-No Project/No Development Alternative would avoid the project impacts associated with agricultural resources; air quality; biological resources; cultural resources; geology and soils; and hydrology and water quality.

- A. **Finding.** Alternative 1 is infeasible. It is found pursuant to Public Resources Code Section 21081(a)(3), that specific economic, legal, social, technological, or other considerations, make Alternative 1 infeasible.
- B. **Facts in Support of Findings.** Alternative 1- No Project/No Development Alternative is rejected as infeasible because it will not meet the primary objectives of the proposed project which include:
 - Construct and operate a solar energy facility capable of producing up to 100 MW AC of electricity to assist the State of California in achieving its 60 percent renewable portfolio standard by 2030.

- Provide a 100 MW BESS system, that would accommodate and store the power generated by the project so that the facility can continue to provide renewable energy during non-daylight hours.
- Interconnect directly to IID's existing electrical transmission system.
- Help California meet its statutory and regulatory goal of increasing renewable power generation, including greenhouse gas reduction goals of Senate Bill 32.

Additionally, the No Project/No Development Alternative would not help California meet its statutory and regulatory goal of increasing renewable power generation, including GHG reduction goals of SB 32.

For the reasons stated above, the County finds that this alternative is infeasible and less desirable than the proposed project and rejects this alternative.

10.2 Alternative 2 – Reduced Project Site

The purpose of this alternative is to reduce the size of the project site to minimize impacts on biological resources by increasing the setback of the project from sensitive vegetation communities and aquatic resources. Tamarisk thickets, identified by CDFW as a sensitive natural community, have been mapped on the northern parcel (APN 059-300-015) of the project site. Freshwater forested/shrub wetland, riparian habitat, and disturbed riparian habitat have also been mapped on the northern parcel of the project site. This alternative would remove the northern parcel (APN 059-300-015), thereby reducing the project site by 301 acres from 450 acres to 149 acres.

This alternative would meet most of the basic objectives of the proposed project.

- A. Finding.** It is found pursuant to Public Resources Code Section 21081(a)(3), that specific economic, legal, social, technological, or other considerations, make Alternative 2 infeasible.
- B. Facts in Support of Findings.** The purpose of studying alternatives to the proposed project is to identify alternatives that would substantially reduce or avoid the significant environmental impacts of the proposed project. This alternative would reduce impacts to agricultural resources, air quality, biological resources, cultural resources, hydrology/water quality, and utilities/service systems compared to the proposed project.

However, this alternative would make it more difficult to achieve the overall objective of providing a total of 100 MW of renewable solar energy, as there would be less area available for the placement of PV structures.

For the reasons stated above, the County finds that this alternative is infeasible and less desirable than the proposed project and rejects this alternative.

10.3 Findings Regarding Range of Alternatives

- A. Finding.** The EIR considers a reasonable range of alternatives. Substantial evidence supports the conclusion of the EIR regarding alternatives considered and rejected.
- B. Facts in Support of Findings.** The purpose of studying alternatives to the proposed project is to identify alternatives that would substantially reduce or avoid the significant environmental impacts of the proposed project. Substantial evidence shows that all potentially significant environmental impacts of the proposed project are mitigated below significant levels and that

no significant unavoidable significant environmental impacts remain. Consequently, the range of alternatives studied in the EIR is reasonable because it included two alternatives to the proposed project despite there being no significant unavoidable environmental impacts necessitating consideration of alternatives to substantially reduce or avoid such impacts. Although some alternatives would reduce the less-than-significant impacts of the proposed project, CEQA does not require that such alternatives be adopted.

Findings Regarding Growth Inducing Impacts

The proposed project is located within the unincorporated area of Imperial County, and it does not involve the development of permanent residences that would directly result in population growth in the area. The unemployment rate in Imperial County, as of September 2022, was 16.0 percent (State of California Employment Development Department 2022). The applicant expects to utilize construction workers from the local and regional area, a workforce similar to that involved in the development of other utility-scale solar facilities. Based on the unemployment rate, and the availability of the local workforce, construction of the proposed project would not have a growth-inducing effect related to workers moving into the area and increasing the demand for housing and services.

Once construction is completed, the facility would be remotely operated, controlled and monitored and with no requirement for daily on-site employees. Security personnel may conduct unscheduled security rounds and would be dispatched to the project site in response to a fence breach or other alarm. It is anticipated that maintenance of the facilities would require minimal site presence to perform periodic visual inspections and minor repairs. On intermittent occasions, the presence of additional workers may be required for repairs or replacement of equipment and panel cleaning; however, because of the nature of the facility, such actions would likely occur infrequently. Overall, minimal maintenance requirements are anticipated. The proposed project would not result in substantial population growth, as the number of employees required to operate and maintain the facility is minimal.

While the proposed project would contribute to energy supply, which indirectly supports population growth, the proposed project is a response to the state's need for renewable energy to meet its Renewable Portfolio Standard, and while it would increase the availability of renewable energy, it would also replace existing sources of non-renewable energy. Unlike a gas-fired power plant, the proposed project is not being developed as a source of base-load power in response to growth in demand for electricity. The power generated would be added to the state's electricity grid with the intent that it would displace fossil fueled power plants and their associated environmental impacts, consistent with the findings and declarations in SB 100 that a benefit of the Renewable Portfolio Standard is displacing fossil fuel consumption within the state. The project is being proposed in response to state policy and legislation promoting development of renewable energy.

The proposed project would supply energy to accommodate and support existing demand and projected growth, but the energy provided by the project would not foster any new growth because (1) the additional energy would be used to ease the burdens of meeting existing statewide energy demands within and beyond the area of the project site; (2) the energy would be used to support already-projected growth; or, (3) the factors affecting growth are so diverse that any potential connection between additional energy production and growth would necessarily be too speculative and uncertain to merit further analysis.

Under CEQA, an EIR should consider potentially significant energy implications of a project (CEQA Guidelines Appendix F(II); PRC Section 21100(b)(3)). However, the relationship between the proposed project's increased electrical capacity and the growth-inducing impacts outside the

surrounding area is too speculative and uncertain to warrant further analysis. When a project's growth-inducing impacts are speculative, the lead agency should consider 14 CCR §15145, which provides that, if an impact is too speculative for evaluation, the agency should note this conclusion and terminate discussion of the impact. As the court explained in *Napa Citizens for Honest Gov't v. Napa County Board of Supervisors*, 91 Cal. App.4th 342, 368: "Nothing in the Guidelines, or in the cases, requires more than a general analysis of projected growth" *Napa Citizens*, 91 CA4th at 369. The problem of uncertainty of the proposed project's growth-inducing effects cannot be resolved by collection of further data because of the diversity of factors affecting growth.

While the EIR has considered that the proposed project, as an energy project, might foster regional growth, the particular growth that could be attributed to the proposed project is unpredictable, given the multitude of variables at play, including uncertainty about the nature, extent, and location of growth and the effect of other contributors to growth besides the proposed project. No accurate and reliable data is available that could be used to predict the amount of growth outside the area that would result from the proposed project's contribution of additional electrical capacity. The County of Imperial has not adopted a threshold of significance for determining when an energy project is growth-inducing. Further evaluation of this impact is not required under CEQA.

Additionally, the project would not involve the development of any new roadways, new water systems, or sewer; and thus, the project would not further facilitate additional development into outlying areas. For these reasons, the proposed project would not be growth-inducing.

Findings Regarding Significant Irreversible Environmental Changes

Energy resources needed for the construction of the proposed project would contribute to the incremental depletion of renewable and non-renewable resources. Resources, such as timber, used in building construction are generally considered renewable and would ultimately be replenished. Non-renewable resources, such as petrochemical construction materials, steel, copper, lead and other metals, gravel, concrete, and other materials, are typically considered finite and would not be replenished over the lifetime of the project. Thus, the project would irretrievably commit resources over the anticipated 30-year life of the project.

At the end of the project's operation term, the applicant may determine that the project should be decommissioned and deconstructed. Should the project be decommissioned, the project applicant is required to restore land to its pre-project state. Consequently, some of the resources on the site could potentially be retrieved after the site has been decommissioned. Concrete footings, foundations, and pads would be removed and recycled at an off-site location. All remaining components would be removed, and all disturbed areas would be reclaimed and recontoured. The applicant anticipates using the best available recycling measures at the time of decommissioning.

Implementation and operation of the proposed project would promote the use of renewable energy and contribute incrementally to the reduction in demand for fossil fuel use for electricity-generating purposes. Therefore, the incremental reduction in fossil fuels would be a positive effect of the commitment of nonrenewable resources. Additionally, the project is consistent with the state's definition of an "eligible renewable energy resource" in Section 399.12 of the California Public Utilities Code and the definition of "in-state renewable electricity generation facility" in Section 25741 of the California PRC.

1. The County of Imperial (the County), acting through the Board of Supervisors, is the Lead Agency for the project evaluated in the EIR. The County finds that the EIR was prepared in compliance with CEQA and the CEQA Guidelines. The County finds that it has independently reviewed and

analyzed the EIR for the project, that the Draft EIR which was circulated for public review reflected its independent judgment and that the Final EIR reflects the independent judgment of the County.

2. The County finds that the EIR provides objective information to assist the decision-makers and the public at large in their consideration of the environmental consequences of the project. The public review period provided all interested jurisdictions, agencies, private organizations, and individuals the opportunity to submit comments regarding the Draft EIR. The Final EIR was prepared after the review period and responds to comments made during the public review period.
3. The Planning and Development Services Department evaluated comments on environmental issues received from persons who reviewed the Draft EIR. In accordance with CEQA, the Planning and Development Services Department prepared written responses describing the disposition of significant environmental issues raised. The Final EIR provides adequate, good faith and reasoned responses to the comments. The Planning Department reviewed the comments received and responses thereto and has determined that neither the comments received nor the responses to such comments add significant new information regarding environmental impacts to the Draft EIR. The Lead Agency has based its actions on full appraisal of all viewpoints, including all comments received up to the date of adoption of these findings, concerning the environmental impacts identified and analyzed in the EIR.
4. The EIR evaluated the following potential project and cumulative environmental impacts:
 - Aesthetics
 - Agriculture Resources
 - Air Quality
 - Biological Resources
 - Cultural Resources
 - Geology and Soils
 - GHG Emissions
 - Hazards and Hazardous Materials
 - Hydrology/Water Quality
 - Land Use/Planning
 - Noise and Vibration
 - Transportation
 - Tribal Cultural Resources
 - Utilities/Service Systems (Water Supply)

Additionally, the EIR considered, in separate sections, Analysis of Long-Term Effects and potential secondary effects of the project. The significant environmental impacts of the project were identified in the Final EIR. The significant environmental impacts of the project and the alternatives were also identified in the Draft and Final EIR.

5. The mitigation measures which have been identified for the project were identified in the Draft and Final EIR. The final mitigation measures are described in the MMRP. Each of the mitigation measures identified in the MMRP, and contained in the Final EIR, is incorporated into the project.

The County finds that the impacts of the project have been mitigated to the extent feasible by the mitigation measures identified in the MMRP, and contained in the Final EIR.

6. Textual refinements and errata were compiled and presented to the decision-makers for review and consideration. The Planning and Development Services Department staff has made every effort to notify the decision-makers and the interested public/agencies of each textual change in the various documents associated with the project review. These textual refinements arose for a variety of reasons. First, it is inevitable that draft documents would contain errors and would require clarifications and corrections. Second, textual clarifications were necessitated in order to describe refinements suggested as part of the public participation process.
7. The responses to the comments on the Draft EIR, which are contained in the Final EIR, clarify and amplify the analysis in the Draft EIR.
8. Having reviewed the information contained in the EIR and in the administrative record as well as the requirements of CEQA and the CEQA Guidelines regarding recirculation of Draft EIRs, the County finds that there is no new significant information in the Final EIR, finds that the additional information provided therein merely clarifies, amplifies and/or makes insignificant modifications to the adequate Draft EIR, and finds that recirculation of the Draft EIR is not required.
9. CEQA requires the Lead Agency approving a project to adopt an MMRP for the changes to the project which it has adopted or made a condition of project approval in order to ensure compliance with the mitigation measures during project implementation. The mitigation measures included in the EIR as certified by the County and included in the MMRP as adopted by the County serves that function. The MMRP includes all of the mitigation measures identified in the EIR and adopted by the County in connection with the approval of the project and has been designed to ensure compliance with such measures during implementation of the project. In accordance with CEQA, the MMRP provides the means to ensure that the mitigation measures are fully enforceable. In accordance with the requirements of Public Resources Code §21081.6, the County hereby adopts the MMRP.
10. In accordance with the requirements of Public Resources Code §21081.6, the County hereby adopts each of the mitigation measures expressly set forth herein as conditions of approval for the project.
11. The custodian of the documents or other material which constitute the record of proceedings upon which the County's decision is based is the Imperial County Planning and Development Services Department, 801 Main Street, El Centro, California, 92243.
12. The County finds and declares that substantial evidence for each and every finding made herein is contained in the EIR, which is incorporated herein by this reference, or is in the record of proceedings in the matter.
13. The County is certifying an EIR for, and is approving and adopting findings for, the entirety of the actions described in these Findings and in the EIR as comprising the project. It is contemplated that there may be a variety of actions undertaken by other State and local agencies (who might be referred to as "responsible agencies" under CEQA). Because the County is the Lead Agency for the project, the EIR is intended to be the basis for compliance with CEQA for each of the possible discretionary actions by other State and local agencies to carry out the project.
14. The EIR is a Project EIR for purposes of environmental analysis of the project. A Project EIR examines the environmental effects of a specific project. The EIR serves as the primary

environmental compliance document for entitlement decisions regarding the project by the County of Imperial and the other regulatory jurisdictions.



This page is intentionally blank.

Attachment D:
MMRP

RESOLUTION NO.

A RESOLUTION OF THE PLANNING COMMISSION OF THE COUNTY OF IMPERIAL, CALIFORNIA, RECOMMENDING APPROVAL OF THE MITIGATION MONITORING AND REPORTING PROGRAM FOR THE VEGA SES 4 SOLAR ENERGY STORAGE PROJECT

WHEREAS, a Mitigation Monitoring and Reporting Program has been prepared in accordance with the requirements of the California Environmental Quality Act, the State CEQA Guidelines, and the County's Rules to Implement CEQA as amended; and

WHEREAS, the Planning Commission of the County of Imperial has been delegated with the responsibility of the consideration for recommending to the Board of Supervisors the approval of the Mitigation Monitoring and Reporting Program; and

WHEREAS, public notice of said application has been given, and Planning Commission has considered evidence presented by the Imperial County Planning & Development Services Department, and other interested parties at a public hearing held with respect to this item on May 24, 2023; and,

NOW THEREFORE, the Planning Commission of the County of Imperial **DOES HEREBY RESOLVE** as follows:

SECTION 1. The Planning Commission has considered the proposed Mitigation Monitoring and Reporting Program (MM&RP) prior to making a decision to recommend the adoption of the proposed MM&RP. The Planning Commission finds and determines that the Environmental Impact Report is adequate and prepared in accordance with the requirements of the California Environmental Quality Act (CEQA), which analyzes environmental effects, based upon the following findings and determinations.

SECTION 2. That in accordance with CEQA, State Planning and Zoning law, Imperial County Land Use Ordinance and the County of Imperial General Plan, the following findings for recommending the approval of the MM&RP as follows:

1. That the Final Project EIR **SCH #2021050018**, Candidate CEQA Findings for the Vega SES Solar Energy Storage Project ("Project") have been prepared in accordance with the requirements of the California Environmental Quality Act, the State CEQA Guidelines, and the County's "Rules and Regulations to Implement CEQA as amended".

2. That the County has reviewed, analyzed, and considered Final Project EIR, the environmental impacts therein identified for this Project, the Candidate CEQA Findings, and the Mitigation Monitoring and Reporting Program, and the entire Record of Proceedings prior to approving this project.

3. That the Mitigation Monitoring and Reporting Program is designed to ensure that during project implementation, the Developer and any other responsible parties implement the Project components and comply with feasible mitigation measures identified in the CEQA Findings, the Project entitlements, and the Mitigation Monitoring and Reporting Program and that these measures are fully enforceable through permit conditions, agreements, and/or other measures, such as their inclusion in the Mitigation Monitoring and Reporting Program.

4. That the Project will not individually or cumulative have an unmitigated adverse effect on fish and wildlife resources, as defined in Section 711.2 of the Fish and Game Code.

5. That the Record of Proceedings consists of the Final Project EIR (and all its technical reports and addendums thereto); the County staff reports; the CEQA Findings; the Mitigation Monitoring and Reporting Program; the various Project entitlements and documents referenced therein; all final reports, applications, memoranda, maps, letters, and other planning documents prepared by the EIR planning/environmental consultant; all final reports, memoranda, maps, letters, and other planning documents prepared by the County staff; all documents submitted by members of the public and public agencies in connection with the Final Project EIR; minutes and transcripts of all public meetings and public hearings; all written and verbal public testimony presented during a noticed public hearing for the proposed project which such testimony was taken and any and all other materials which constitute the record of proceeding pursuant to Public Resources Code section 21167.6(e); and matters of common knowledge to the County staff, Planning Commission, including, but not limited to the County General Plan, the County Zoning Ordinance, County policies, which may be found at the Clerk's Office located at 940 Main Street, Suite 209, El Centro, CA, 92243 during regular business hours, and the Imperial County Planning & Development Services Department at 801 Main Street, El Centro, CA 92243.

6. That the County Planning Commission does hereby recommend to the Board of Supervisors to approve of the Mitigation Monitoring and Reporting Program.

NOW, THEREFORE, based on the above findings, the **IMPERIAL COUNTY PLANNING COMMISSION DOES HEREBY RECOMMEND TO THE BOARD OF SUPERVISORFS TO APPROVE OF** the Mitigation Monitoring Reporting Program (MMRP),

Rudy Schaffner, Chairperson
Imperial County Planning Commission

PLANNING COMMISSION RESOLUTION FOR
MMRP

Page 3 of 3

I hereby certify that the Planning Commission at a meeting conducted on **May 24, 2023** by the following vote took the preceding resolution:

AYES:

NOES:

ABSENT:

ABSTAIN:

ATTEST:

Jim Minnick, Director of Planning & Development Services
Secretary to the Planning Commission

S:APN\059\300\015\cup20-0020pc\MMRP\resolutiondocx

PC ORIGINAL PKG



0.4 Mitigation Monitoring and Reporting Program

The County of Imperial will adopt this Mitigation Monitoring and Reporting Program (MMRP) in accordance with Public Resources Code (PRC) Section 21081.6 and Section 15097 of the California Environmental Quality Act (CEQA) Guidelines. The purpose of the MMRP is to ensure that the VEGA SES 4 Solar Energy Project, which is the subject of the Environmental Impact Report (EIR), complies with all applicable environmental mitigation requirements. The mitigation measures for the project will be adopted by the County of Imperial, in conjunction with the certification of the Final EIR. The mitigation measures have been integrated into this MMRP.

The mitigation measures are provided in Table 0.4-1. The specific mitigation measures are identified, as well as the monitoring method, responsible monitoring party, monitoring phase, verification/approval party, date mitigation measure verified or implemented, location of documents (monitoring record), and completion requirement for each mitigation measure.

The mitigation measures applicable to the project include avoiding certain impacts altogether, minimizing impacts by limiting the degree or magnitude of the action and its implementation, and/or reducing or eliminating impacts over time by maintenance operations during the life of the action.

Public Resources Code Section 21081.6 requires the Lead Agency, for each project that is subject to CEQA, to monitor performance of the mitigation measures included in any environmental document to ensure that implementation does, in fact, take place. The County of Imperial is the designated CEQA lead agency for the Mitigation Monitoring and Reporting Program. The County of Imperial is responsible for review of all monitoring reports, enforcement actions, and document disposition as it relates to impacts within the County's jurisdiction. The County of Imperial will rely on information provided by the monitor as accurate and up to date and will field check mitigation measure status as required.

A record of the MMRP will be maintained at County of Imperial, Department of Planning and Development Services, 801 Main Street, El Centro, CA 92243. All mitigation measures contained in the EIR shall be made conditions of the project as may be further described below.

This page is intentionally blank.



Table 0.4-1. Mitigation Measures

MM No.	Mitigation Measure	Monitoring Method	Responsible Monitoring Party	Monitoring Phase	Verification/Approval Party	Date Mitigation Measure Verified or Implemented	Location of Documents (Monitoring Record)	Completion Requirement
AG-1	<p>Agricultural Resources</p> <p>Pest Management Plan. Prior to the issuance of a grading permit or building permit (whichever occurs first), a Pest Management Plan shall be developed by the project applicant and approved by the County of Imperial Agricultural Commissioner. The project applicant shall maintain a Pest Management Plan until reclamation is complete. The plan shall provide the following:</p> <ol style="list-style-type: none"> Monitoring, preventative, and management strategies for weed and pest control during construction activities at any portion of the project (e.g., transmission line). Control and management of weeds and pests in areas temporarily disturbed during construction where native seed will aid in site revegetation as follows: <ul style="list-style-type: none"> Monitor for all pests including insects, vertebrates, weeds, and pathogens. Promptly control or eradicate pests when found, or when notified by the Agricultural Commissioner's office that a pest problem is present on the project site. The assistance of a licensed pest control advisor is recommended. All treatments must be performed by a qualified applicator or a licensed pest control business; All treatments must be performed by a qualified applicator or a licensed pest control operator; "Control" means to reduce the population of common pests below economically damaging levels and includes attempts to exclude pests before infestation, and effective control methods after infestation. Effective control methods may include physical/mechanical removal, bio control, cultural control, or chemical treatments; Use of "permanent" soil sterilants to control weeds or other pests is prohibited because this would interfere with reclamation; 	<p>The Department of Planning and Development Services shall verify that a Pest Management Plan has been reviewed and approved by the Imperial County Agricultural Commissioner.</p>	<p>Department of Planning and Development Services and Imperial County Agricultural Commissioner</p>	<p>Prior to the issuance of a grading permit or building permit, during construction</p>	<p>Department of Planning and Development Services and Imperial County Agricultural Commissioner</p>			

Table 0.4-1. Mitigation Measures

MM No.	Mitigation Measure	Monitoring Method	Responsible Monitoring Party	Monitoring Phase	Verification/Approval Party	Date Mitigation Measure Verified or Implemented	Location of Documents (Monitoring Record)	Completion Requirement
	<ul style="list-style-type: none"> Notify the Agricultural Commissioner's office immediately regarding any suspected exotic/invasive pest species as defined by the California Department of Food Agriculture and the U.S. Department of Agriculture. Request a sample be taken by the Agricultural Commissioner's Office of a suspected invasive species. Eradication of exotic pests shall be done under the direction of the Agricultural Commissioner's Office and/or California Department of Food and Agriculture. Obey all pesticide use laws, regulations, and permit conditions; Allow access by Agricultural Commissioner staff for routine visual and trap pest surveys, compliance inspections, eradication of exotic pests, and other official duties; Ensure all project employees that handle pest control issues are appropriately trained and certified, all required records are maintained and made available for inspection, and all required permits and other required legal documents are current; Maintain records of pests found and treatments or pest management methods used. Records should include the date, location/block, project name (current and previous if changed), and methods used. For pesticides include the chemical(s) used, EPA Registration numbers, application rates, etc. A pesticide use report may be used for this; Submit a report of monitoring, pest finds, and treatments, or other pest management methods to the Agricultural Commissioner quarterly within 15 days after the end of the previous quarter, and upon request. The report is required even if no pests were found or treatment occurred. It may consist of a copy of all records for the previous quarter, or may be a summary letter/report as long as the original detailed records are available upon request. 							



Table 0.4-1. Mitigation Measures

MM No.	Mitigation Measure	Monitoring Method	Responsible Monitoring Party	Monitoring Phase	Verification/Approval Party	Date Mitigation Measure Verified or Implemented	Location of Documents (Monitoring Record)	Completion Requirement
	<p>3. A long-term strategy for weed and pest control and management during the operation of the proposed projects. Such strategies may include, but are not limited to:</p> <ul style="list-style-type: none"> Use of specific types of herbicides and pesticides on a scheduled basis. <p>4. Maintenance and management of project site conditions to reduce the potential for a significant increase in pest-related nuisance conditions on surrounding agricultural lands.</p> <p>5. The project shall reimburse the Agricultural Commissioner's office for the actual cost of investigations, inspections, or other required non-routine responses to the site that are not funded by other sources.</p>							
Air Quality								
AQ-1	<p>Fugitive Dust Control. During construction activities, the contractor/contractor shall employ the following PM₁₀ reducing measures:</p> <ol style="list-style-type: none"> All unpaved roads associated with construction shall be effectively stabilized of dust emissions using Imperial County Air Pollution Control District-approved chemical stabilizers/suppressant before the commencement of construction, and every 30 days thereafter until the end of all construction activities. Unpaved roads associated with construction include: <ul style="list-style-type: none"> The driveway entrance off State Route 98; The project designated 3.5-acre staging/parking area north of the All-American Canal; The 1.0 mile of dirt road south of the All-American Canal; and The 20 miles of existing dirt road paralleling the U.S./Mexico Border from Gordon Wells Road to the project site. <p>Monthly application of Imperial County Air Pollution Control District-approved chemical stabilizers/suppressant shall be applied at a rate of 0.1 gallon/square yard of chemical dust suppressant.</p>	<p>Prior to and during construction, the CAPCD will verify that the project is in compliance with the fugitive dust control measures as identified in Mitigation Measure AQ-1 and Regulation VIII-Fugitive Dust Control Measures.</p>	<p>Department of Planning and Development Services and ICAPCD</p>	<p>Prior to and during construction</p>	<p>Department of Planning and Development Services and ICAPCD</p>			

Table 0.4-1. Mitigation Measures

MM No.	Mitigation Measure	Monitoring Method	Responsible Monitoring Party	Monitoring Phase	Verification/Approval Party	Date Mitigation Measure Verified or Implemented	Location of Documents (Monitoring Record)	Completion Requirement
2.	<p>Prior to any earthmoving activity, the applicant shall submit a construction dust control plan and obtain Imperial County Air Pollution Control District and Imperial County Planning and Development Services Department (ICPDS) approval.</p>							
3.	<p>Pursuant to ICAPCD, all construction sites, regardless of size, must comply with the requirements contained within Regulation VIII – Fugitive Dust Control Measures. Whereas these Regulation VIII measures are mandatory and are not considered project environmental mitigation measures, the ICAPCD CEQA Handbook’s required additional standard and enhanced mitigation measures listed below shall be implemented prior to and during construction. ICAPCD will verify implementation and compliance with these measures as part of the grading permit review/approval process.</p> <p>ICAPCD Standard Measures for Fugitive Dust (PM₁₀) Control</p> <ul style="list-style-type: none"> All disturbed areas, including bulk material storage, which is not being actively utilized, shall be effectively stabilized and visible emissions shall be limited to no greater than 20 percent opacity for dust emissions by using water, chemical stabilizers, dust suppressants, tarps, or other suitable material, such as vegetative ground cover. All on-site and offsite unpaved roads will be effectively stabilized and visible emissions shall be limited to no greater than 20 percent opacity for dust emissions by paving, chemical stabilizers, dust suppressants, and/or watering. All unpaved traffic areas 1 acre or more with 75 or more average vehicle trips per day will be effectively stabilized and visible emissions shall be limited to no greater than 20 percent opacity for dust emissions by paving, chemical stabilizers, dust suppressants, and/or watering. The transport of bulk materials shall be completely covered unless 6 inches of freeboard space from the top of the container is maintained with no spillage and loss of bulk material. In 							



Table 0.4-1. Mitigation Measures

MM No.	Mitigation Measure	Monitoring Method	Responsible Monitoring Party	Monitoring Phase	Verification/Approval Party	Date Mitigation Measure Verified or Implemented	Location of Documents (Monitoring Record)	Completion Requirement
	<p>addition, the cargo compartment of all haul trucks is to be cleaned and/or washed at delivery site after removal of bulk material.</p> <ul style="list-style-type: none"> All track-out or carry-out will be cleaned at the end of each workday or immediately when mud or dirt extends a cumulative distance of 50 linear feet or more onto a paved road within an urban area. Movement of bulk material handling or transfer shall be stabilized prior to handling or at points of transfer with application of sufficient water, chemical stabilizers, or by sheltering or enclosing the operation and transfer line. The construction of any new unpaved road is prohibited within any area with a population of 500 or more unless the road meets the definition of a temporary unpaved road. Any temporary unpaved road shall be effectively stabilized and visible emissions shall be limited to no greater than 20 percent opacity for dust emission by paving, chemical stabilizers, dust suppressants, and/or watering. 							
	<p>ICAPCD "Discretionary" Measures for Fugitive Dust (PM₁₀) Control</p> <ul style="list-style-type: none"> Water exposed soil only in those areas where active grading and vehicle movement occurs with adequate frequency to control dust. Replace ground cover in disturbed areas as quickly as possible. Automatic sprinkler system installed on all soil piles. Vehicle speed for all construction vehicles shall not exceed 15 miles per hour on any unpaved surface at the construction site. Develop a trip reduction plan to achieve a 1.5 average vehicle ridership for construction employees. Implement a shuttle service to and from retail services and food establishments during lunch hours. 							
	<p>Standard Mitigation Measures for Construction Combustion Equipment</p>							

Table 0.4-1. Mitigation Measures

MM No.	Mitigation Measure	Monitoring Method	Responsible Monitoring Party	Monitoring Phase	Verification/Approval Party	Date Mitigation Measure Verified or Implemented	Location of Documents (Monitoring Record)	Completion Requirement
	<ul style="list-style-type: none"> Use of alternative fueled or catalyst equipped diesel construction equipment, including all off-road and portable diesel-powered equipment. Minimize idling time either by shutting equipment off when not in use or reducing the time of idling to 5 minutes as a maximum. Limit, to the extent feasible, the hours of operation of heavy-duty equipment and/or the amount of equipment in use. Replace fossil fueled equipment with electrically driven equivalents (provided they are not run via a portable generator set). 							
	<p>Enhanced Mitigation Measures for Construction Equipment</p> <p>To help provide a greater degree of reduction of PM emissions from construction combustion equipment, ICAPCD recommends the following enhanced measures.</p> <ul style="list-style-type: none"> Curtail construction during periods of high ambient pollutant concentrations; this may include ceasing of construction activity during the peak hour of vehicular traffic on adjacent roadways. Implement activity management (e.g., rescheduling activities to reduce short-term impacts). 							
AQ-2	<p>Construction Equipment. Construction equipment shall be equipped with an engine designation of EPA Tier 2 or better (Tier 2+). A list of the construction equipment, including all off-road equipment utilized at the project site by make, model, year, horsepower and expected/actual hours of use, and the associated EPA Tier shall be submitted to the County Planning and Development Services Department and ICAPCD prior to the issuance of a grading permit. The equipment list shall be submitted periodically to ICAPCD to perform a NOx analysis. ICAPCD shall utilize this list to calculate air emissions to verify that equipment use does not exceed significance thresholds. The Planning and Development Services Department and ICAPCD shall verify implementation of this measure.</p>	<p>Prior to the issuance of a grading permit, ICAPCD shall verify that construction equipment is equipped with an engine designation of EPA Tier 2 or better.</p> <p>The equipment list shall be submitted periodically to ICAPCD to perform a NOx analysis.</p>	<p>Department of Planning and Development Services and ICAPCD</p>	<p>Prior to the issuance of a grading permit and during construction</p>	<p>Department of Planning and Development Services and ICAPCD</p>			



Table 0.4-1. Mitigation Measures

MM No.	Mitigation Measure	Monitoring Method	Responsible Monitoring Party	Monitoring Phase	Verification/Approval Party	Date Mitigation Measure Verified or Implemented	Location of Documents (Monitoring Record)	Completion Requirement
AQ-3	Dust Suppression. The project applicant shall employ a method of dust suppression (such as water or chemical stabilization) approved by ICAPCD. The project applicant shall apply chemical stabilization as directed by the product manufacturer to control dust between the panels as approved by ICAPCD, and other non-used areas (exceptions will be the paved entrance and parking area, and Fire Department access/emergency entry/exit points as approved by Fire/ Office of Emergency Services [OES] Department).	During construction, the Department of Planning and Development Services shall verify that the project applicant is employing a method of dust suppression approved by ICAPCD.	Department of Planning and Development Services	During construction	Department of Planning and Development Services			
AQ-4	Operational Dust Control Plan. Prior to issuance of a Certificate of Occupancy, the applicant shall submit an operations dust control plan and obtain ICAPCD and ICPDS approval. ICAPCD Rule 301 Operational Fees apply to any project applying for a building permit. At the time that building permits are submitted for the proposed project, the ICAPCD shall review the project to determine if Rule 310 fees are applicable to the project.	Prior to the issuance of a Certificate of Occupancy, the applicant shall submit an operations dust control plan and obtain ICAPCD and ICPDS approval.	Department of Planning and Development Services	Prior to the issuance of a Certificate of Occupancy	Department of Planning and Development Services and ICAPCD			

Biological Resources

BIO-1	Rare Plant Surveys. Prior to initiating ground disturbance, rare plant surveys shall be conducted within suitable habitat on the project site during the appropriate blooming period for the Abrams' spurge (approximately September through November), Wiggins' croton (approximately March through May), and sand food (approximately April through June). The surveys shall be conducted by a botanist or qualified biologist in accordance with the USFWS Guidelines for Conducting and Reporting Botanical Inventories for Federally Listed, Proposed, and Candidate Plants (USFWS 1996); the CDFW Protocols for Surveying and Evaluating Impacts to Special Status Native Plant Populations and Sensitive Natural Communities (CDFW 2019); and the CNPS Botanical Survey Guidelines (CNPS, 2001). If any special-status species are observed during the rare plant surveys, the location of the individual plant or population will be recorded with a submeter GPS device for mapping purposes. If project-related impacts to rare plants on the project site are unavoidable, then consultation with CDFW may be required to develop a mitigation plan or additional	Prior to initiating ground disturbance, the Department of Planning and Development Services shall verify that rare plant surveys have been conducted on the project site.	Department of Planning and Development Services	Prior to construction	Department of Planning and Development Services			
-------	-------------------------------------------------------------------------------------------------------------------------------------------------------------------------------------------------------------------------------------------------------------------------------------------------------------------------------------------------------------------------------------------------------------------------------------------------------------------------------------------------------------------------------------------------------------------------------------------------------------------------------------------------------------------------------------------------------------------------------------------------------------------------------------------------------------------------------------------------------------------------------------------------------------------------------------------------------------------------------------------------------------------------------------------------------------------------------------------------------------------------------------------------------------------------------------	---------------------------------------------------------------------------------------------------------------------------------------------------------------------------	-------------------------------------------------	-----------------------	-------------------------------------------------	--	--	--

Table 0.4-1. Mitigation Measures

MM No.	Mitigation Measure	Monitoring Method	Responsible Monitoring Party	Monitoring Phase	Verification/Approval Party	Date Mitigation Measure Verified or Implemented	Location of Documents (Monitoring Record)	Completion Requirement
	<p>avoidance and minimization measures. Mitigation measures that may be implemented if the species is observed include establishing a no-disturbance buffer around locations of individuals or a population, salvage or seed collection, and additional monitoring requirements.</p> <p>BIO-2 General Impact Avoidance and Minimization Measures. The following measures will be applicable throughout the life of the project.</p> <ul style="list-style-type: none"> To reduce the potential indirect impact on migratory birds, bats and raptors, the project will comply with the APLIC 2012 Guidelines for overhead utilities, as appropriate, to minimize avian collisions with transmission facilities (APLIC 2012). All electrical components on the project site shall be either undergrounded or protected so that there will be no exposure to wildlife and therefore no potential for electrocution. The project proponent shall designate a Project Biologist who shall be responsible for overseeing compliance with protective measures for the biological resources during vegetation clearing and work activities within and adjacent to areas of native habitat. The Project Biologist will be familiar with the local habitats, plants, and wildlife. The Project Biologist will also maintain communications with the Contractor to ensure that issues relating to biological resources are appropriately and lawfully managed and monitor construction. The Project Biologist will monitor activities within construction areas during critical times, such as vegetation removal, the implementation of Best Management Practices (BMP), and installation of security fencing to protect native species. The Project Biologist will ensure that all wildlife and regulatory agency permit requirements, conservation measures, and general avoidance and minimization measures are properly implemented and followed. The boundaries of all areas to be newly disturbed (including solar facility areas, staging areas, access roads, and sites for temporary placement of construction materials and spoils) will be 	<p>The measures as provided in Mitigation Measure BIO-2 shall be implemented throughout the life of the project.</p>	<p>Department of Planning and Development Services</p>	<p>Prior to construction, during construction, and post-construction</p>	<p>Department of Planning and Development Services</p>			

Table 0.4-1. Mitigation Measures

MM No.	Mitigation Measure	Monitoring Method	Responsible Monitoring Party	Monitoring Phase	Verification/Approval Party	Date Mitigation Measure Verified or Implemented	Location of Documents (Monitoring Record)	Completion Requirement
	<ul style="list-style-type: none"> delineated with stakes and flagging prior to disturbance. All disturbances, vehicles, and equipment will be confined to the flagged areas. No potential wildlife entrapments (e.g., trenches, bores) will be left uncovered overnight. Any uncovered pitfalls will be excavated to 3:1 slopes at the ends to provide wildlife escape ramps. Alternatively, man-made ramps may be installed. Covered pitfalls will be covered completely to prevent access by small mammals or reptiles. To avoid wildlife entrapment (including birds), all pipes or other construction materials or supplies will be covered or capped in storage or laydown area, and at the end of each work day in construction, quarrying and processing/handling areas. No pipes or tubing of sizes or inside diameters ranging from 1 to 10 inches will be left open either temporarily or permanently. No anticoagulant rodenticides, such as Warfarin and related compounds (indandiones and hydroxycoumarins), may be used within the project site, on off-site project facilities and activities, or in support of any other project activities. Avoid wildlife attractants. All trash and food-related waste shall be placed in self-closing containers and removed regularly from the site to prevent overflow. Workers shall not feed wildlife. Water applied to dirt roads and construction areas for dust abatement shall use the minimal amount needed to meet safety and air quality standards to prevent the formation of puddles, which could attract wildlife. Pooled rainwater or floodwater within retention basins will be removed to avoid attracting wildlife to the active work areas. To minimize the likelihood for vehicle strikes on wildlife, speed limits will not exceed 15 miles per hour when driving on access roads. All vehicles required for O&M must remain on designated access/maintenance roads. Avoid night-time construction lighting or if nighttime construction cannot be avoided use shielded directional lighting pointed downward and towards the interior of the project site, 							

Table 0.4-1. Mitigation Measures

MM No.	Mitigation Measure	Monitoring Method	Responsible Monitoring Party	Monitoring Phase	Verification/Approval Party	Date Mitigation Measure Verified or Implemented	Location of Documents (Monitoring Record)	Completion Requirement
	<p>thereby avoiding illumination of adjacent natural areas and the night sky.</p> <ul style="list-style-type: none"> All construction equipment used for the project will be equipped with properly operating and maintained mufflers. Hazardous materials and equipment stored overnight, including small amounts of fuel to refuel hand-held equipment, will be stored within secondary containment when within 50 feet of open water to the fullest extent practicable. Secondary containment will consist of a ring of sand bags around each piece of stored equipment/structure. A plastic tarp/visqueen lining with no seams shall be placed under the equipment and over the edges of the sandbags, or a plastic hazardous materials secondary containment unit shall be utilized by the Contractor. The Contractor will be required to conduct vehicle refueling in upland areas where fuel cannot enter waters of the U.S. and in areas that do not have potential to support federally threatened or endangered species. Any fuel containers, repair materials, including creosote-treated wood, and/or stockpiled material that is left on site overnight will be secured in secondary containment within the work area and staging/assembly area and covered with plastic at the end of each work day. In the event that no activity is to occur in the work area for the weekend and/or a period of time greater than 48 hours, the Contractor will ensure that all portable fuel containers are removed from the project site. All equipment will be maintained in accordance with manufacturer's recommendations and requirements. Equipment and containers will be inspected daily for leaks. Should a leak occur, contaminated soils and surfaces will be cleaned up and disposed of following the guidelines identified in the Stormwater Pollution Prevention Plan or equivalent, Materials Safety Data Sheets, and any specifications required by other permits issued for the project. 							



Table 0.4-1. Mitigation Measures

MM No.	Mitigation Measure	Monitoring Method	Responsible Monitoring Party	Monitoring Phase	Verification/Approval Party	Date Mitigation Measure Verified or Implemented	Location of Documents (Monitoring Record)	Completion Requirement
	<ul style="list-style-type: none"> The Contractor will utilize off-site maintenance and repair shops as much as possible for maintenance and repair of equipment. If maintenance of equipment must occur onsite, fuel/oil pans, absorbent pads, or appropriate containment will be used to capture spills/leaks within all areas. Where feasible, maintenance of equipment will occur in upland areas where fuel cannot enter waters of the U.S. and in areas that do not have potential to support federally threatened or endangered species. Appropriate BMPs will be used by the Contractor to control erosion and sedimentation and to capture debris and contaminants from bridge construction to prevent their deposition in waterways. No sediment or debris will be allowed to enter the creek or other drainages. All debris from construction of the bridge will be contained so that it does not fall into channel. Appropriate BMPs will be used by the Contractor during construction to limit the spread of resuspended sediment and to contain debris. Erosion and sediment control devices used for the proposed project, including fiber rolls and bonded fiber matrix, will be made from biodegradable materials such as jute, with no plastic mesh, to avoid creating a wildlife entanglement hazard. Firearms, open fires, and pets would be prohibited at all work locations and access roads. Smoking would be prohibited along the project alignment. Cross-country vehicle and equipment use outside of approved designated work areas and access roads shall be prohibited to prevent unnecessary ground and vegetation disturbance. Any injured or dead wildlife encountered during project-related activities shall be reported to the project biologist, biological monitor, CDFW, or a CDFW-approved veterinary facility as soon as possible to report the observation and determine the best course of action. For special-status species, the Project Biologist shall notify the 							

Table 0.4-1. Mitigation Measures

MM No.	Mitigation Measure	Monitoring Method	Responsible Monitoring Party	Monitoring Phase	Verification/Approval Party	Date Mitigation Measure Verified or Implemented	Location of Documents (Monitoring Record)	Completion Requirement
	<ul style="list-style-type: none"> County, USFWS, and/or CDFW, as appropriate, within 24 hours of the discovery. Stockpiling of material will be allowed only within established work areas. Actively manage the spread of noxious weeds The ground beneath all parked equipment and vehicles shall be inspected for wildlife before moving. 							
BIO-3	<p>Worker Environmental Awareness Program. Prior to project construction, a Worker Environmental Awareness Program shall be developed and implemented by a qualified biologist, and shall be available in both English and Spanish. Handouts summarizing potential impacts to special-status biological resources and the potential penalties for impacts to these resources shall be provided to all construction personnel. At a minimum, the education program shall include the following:</p> <ul style="list-style-type: none"> the purpose for resource protection; a description of special-status species including representative photographs and general ecology; occurrences of USACE, RWQCB, and CDFW regulated features in the project survey area; regulatory framework for biological resource protection and consequences if violated; sensitivity of the species to human activities; avoidance and minimization measures designed to reduce the impacts to special-status biological resources; environmentally responsible construction practices; reporting requirements; the protocol to resolve conflicts that may arise at any time during the construction process; and workers sign acknowledgement form indicating that the Environmental Awareness Training and Education Program that has been completed and would be kept on record. 	<p>Prior to construction, the Department of Planning and Development Services shall verify that a Worker Environmental Awareness Program has been implemented by a qualified biologist. The Department of Planning and Development Services shall verify the completion of the Worker Environmental Awareness Program by obtaining signed acknowledgements forms from workers.</p>	<p>Department of Planning and Development Services</p>	<p>Prior to construction</p>	<p>Department of Planning and Development Services</p>			

Table 0.4-1. Mitigation Measures

MM No.	Mitigation Measure	Monitoring Method	Responsible Monitoring Party	Monitoring Phase	Verification/Approval Party	Date Mitigation Measure Verified or Implemented	Location of Documents (Monitoring Record)	Completion Requirement
BIO-4	<p>Burrowing Owl Avoidance and Minimization. Take Avoidance (pre-construction) surveys for burrowing owl shall be completed prior to project construction. Surveys shall be conducted as detailed within Appendix D of the Staff Report on Burrowing Owl Mitigation (California Department of Fish and Game [CDFG] 2012). If burrowing owl is not detected, construction may proceed.</p> <ul style="list-style-type: none"> If burrowing owl is identified during the non-breeding season (September 1 through January 31), then a 50-meter buffer will be established by the biological monitor. Construction within the buffer will be avoided until a qualified biologist determines that burrowing owl is no longer present or until a CDFW-approved exclusion plan has been implemented. The buffer distance may be reduced if noise attenuation buffers such as hay bales are placed between the occupied burrow and construction activities. If burrowing owl is identified during the breeding season (February 1 through August 31), then an appropriate buffer will be established by the biological monitor in accordance with the Staff Report on Burrowing Owl Mitigation (CDFG 2012). Construction within the buffer will be avoided until a qualified biologist determines that burrowing owl is no longer present or until young have fledged. The buffer distance may be reduced in consultation with CDFW if noise attenuation buffers such as hay bales are placed between the occupied burrow and construction activities. 	<p>Prior to construction, the Department of Planning and Development Services shall verify that pre-construction surveys for burrowing owl were conducted. If burrowing owls are present, the measures as listed in Mitigation Measure BIO-4 shall be implemented.</p>	Department of Planning and Development Services	Prior to construction, during construction	Department of Planning and Development Services			
BIO-5	<p>Pre-Construction Nesting Bird Surveys. If construction or other project activities are scheduled to occur during the bird breeding season (typically February 1 through August 31 for raptors and March 15 through August 31 for the majority of migratory bird species), a pre-construction nesting-bird survey shall be conducted by a qualified avian biologist to ensure that active bird nests, including those for the northern harrier, yellow warbler, burrowing owl, and loggerhead strike, will not be disturbed or destroyed. The survey shall be completed no more than three days prior to initial ground disturbance. The nesting-bird survey shall include the project site and adjacent areas where</p>	<p>Prior to construction, the Department of Planning and Development Services shall verify that a pre-construction nesting bird survey was conducted if project activities are scheduled during the bird breeding season, typically February 1 through August 31 for raptors and March 15 through August 31 for the majority of migratory bird species). If nesting birds are present,</p>	Department of Planning and Development Services	Prior to construction, during construction	Department of Planning and Development Services			

Table 0.4-1. Mitigation Measures

MM No.	Mitigation Measure	Monitoring Method	Responsible Monitoring Party	Monitoring Phase	Verification/Approval Party	Date Mitigation Measure Verified or Implemented	Location of Documents (Monitoring Record)	Completion Requirement
	<p>project activities have the potential to affect active nests, either directly or indirectly due to construction activity or noise. If an active nest is identified, the biologist shall establish an appropriately sized disturbance-limit buffer around the nest using flagging or staking. Construction activities shall not occur within any disturbance-limit buffer zones until the nest is deemed inactive by the qualified biologist. If construction activities cease for a period of greater than three days during the bird breeding season, a pre-construction nesting bird survey shall be conducted prior to the commencement of activities. Final construction buffers or setback distances shall be determined by the qualified biologist in coordination with USFWS and CDFW on a case-by-case basis, depending on the species, season in which disturbance shall occur, the type of disturbance, and other factors that could influence susceptibility to disturbance (e.g., topography, vegetation, existing disturbance levels, etc.).</p>	<p>the measures as listed in Mitigation Measure BIO-5 shall be implemented.</p>						
BIO-6	<p>Pre-Construction Survey for Special-Status Species. A pre-construction survey shall be conducted for special-status wildlife species within all areas of potential permanent and temporary disturbance. The pre-construction survey shall take place no more than 14 days prior to the start of ground-disturbing activities. The pre-construction surveys should take place regardless of breeding season timing and shall focus on identifying the presence of special-status wildlife species present on the project site or that were identified as having a high potential to occur on the site. These species include, but are not limited to, flat-tailed horned lizard, burrowing owl, northern harrier, and yellow warbler. Should any special-status species be identified during the pre-construction survey, consultation to develop suitable avoidance and minimization measures with the appropriate agency (USFWS, CDFW) may need to be undertaken.</p>	<p>Prior to construction, the Department of Planning and Development Services shall verify that a pre-construction survey for special-status species was conducted.</p>	<p>Department of Planning and Development Services</p>	<p>Prior to construction</p>	<p>Department of Planning and Development Services</p>			
BIO-7	<p>Bat Acoustic Surveys and Monitoring. To avoid impacts to bat species, a qualified bat biologist shall conduct an appropriate combination of sampling, exit counts, and acoustic surveys to determine if bats are using the palm tree resources in the project area. If project-related impacts to bat species are unavoidable, additional measures may need to be</p>	<p>Prior to construction, the Department of Planning and Development Services shall verify that bat acoustic surveys have been conducted.</p>	<p>Department of Planning and Development Services</p>	<p>Prior to construction, during construction</p>	<p>Department of Planning and Development Services</p>			



Table 0.4-1. Mitigation Measures

MM No.	Mitigation Measure	Monitoring Method	Responsible Monitoring Party	Monitoring Phase	Verification/Approval Party	Date Mitigation Measure Verified or Implemented	Location of Documents (Monitoring Record)	Completion Requirement
	<p>implemented to reduce or eliminate impacts to bat species, including maternity roosts, such as tree removal occurring outside of bat breeding season (October through February) or two-step, two-day removal of palm trees under supervision of a qualified bat biologist.</p>							
Cultural Resources								
CR-1	<p>Environmentally Sensitive Area Fencing. Prior to issuance of grading permits and in coordination with a qualified archaeologist to be retained by the project applicant, the construction zone shall be narrowed or otherwise altered to avoid Sites 2020-142-001, 2020-142-002, 2020-142-004, 2020-142-005, and 2020-142-008. The area within 100 feet of Sites 2020-142-001, 2020-142-002, 2020-142-004, 2020-142-005, and 2020-142-008 shall be designated Environmentally Sensitive Area (ESA) and fenced or flagged with exclusion markers to ensure avoidance. Protective fencing shall not identify the protected area as a cultural resource area in order to discourage unauthorized disturbance or collection of artifacts. The ESA fencing or flags shall remain in place throughout project construction.</p>	<p>Prior to issuance of grading permits, the Department of Planning and Development Services shall verify the following:</p> <ol style="list-style-type: none"> The construction zone was narrowed or otherwise altered to avoid Sites 2020-142-001, 2020-142-002, 2020-142-004, 2020-142-005, and 2020-142-008. The area within 100 feet of Sites 2020-142-001, 2020-142-004, 2020-142-005, and 2020-142-003 has been designated Environmentally Sensitive Area (ESA) and fenced or flagged with exclusion markers to ensure avoidance. 	<p>Department of Planning and Development Services</p>	<p>Prior to grading</p>	<p>Department of Planning and Development Services</p>			
CR-2	<p>Evaluate Significance of Find (Unknown Cultural Resources). If subsurface deposits believed to be cultural in origin are discovered during construction, all work must halt within a 100-foot radius of the discovery. A qualified professional archaeologist who meets the Secretary of the Interior's Standards for prehistoric and historic archaeology and is familiar with the resources of the region, shall be retained to evaluate the significance of the find, and shall have the authority to modify the no work radius as appropriate, using professional judgment. The following notifications shall apply, depending on the nature of the find:</p>	<p>The Department of Planning and Development Services shall verify that the project applicant has retained a qualified professional archaeologist. If the professional archaeologist determines that the find does represent a cultural resource work may not resume within the no-work radius until the Imperial County Planning and</p>	<p>Department of Planning and Development Services</p>	<p>During grading and construction</p>	<p>Department of Planning and Development Services</p>			

Table 0.4-1. Mitigation Measures

MM No.	Mitigation Measure	Monitoring Method	Responsible Monitoring Party	Monitoring Phase	Verification/Approval Party	Date Mitigation Measure Verified or Implemented	Location of Documents (Monitoring Record)	Completion Requirement
	<ul style="list-style-type: none"> If the professional archaeologist determines that the find does not represent a cultural resource, work may resume immediately, and no agency notifications are required. If the professional archaeologist determines that the find does represent a cultural resource from any time period or cultural affiliation, he or she shall immediately notify the Imperial County Planning and Development Services Department. The Imperial County Planning and Development Services Department shall consult with the professional archaeologist on a finding of eligibility and implement appropriate treatment measures if the find is determined to be an Historical Resource under CEQA, as defined in Section 15064.5(e) of the CEQA Guidelines, or an Historic Property, as defined in 36 CFR 60.4. Work may not resume within the no-work radius until the Imperial County Planning and Development Services Department, through consultation as appropriate, determine that the site either: <ol style="list-style-type: none"> 1) is not an Historical Resource under CEQA or an Historic Property under Section 106; or 2) that the treatment measures have been completed to their satisfaction. 	<p>Development Services Department, through consultation as appropriate, determine that the site either: 1) is not an Historical Resource under CEQA or an Historic Property under Section 106; or 2) that the treatment measures have been completed to their satisfaction.</p>	Department of Planning and Development Services	During grading and construction	Department of Planning and Development Services			
CR-3	<p>Evaluate Significance of Find (Unknown Archaeological Resources). In the event of the discovery of previously unidentified archaeological materials, the contractor shall immediately cease all work activities within approximately 100 feet of the discovery. After cessation of excavation, the contractor shall immediately contact the Imperial County Department of Planning and Development Services Department. Except in the case of cultural items that fall within the scope of the Native American Grave Protection and Repatriation Act, the discovery of any cultural resource within the project area shall not be grounds for a "stop work" notice or otherwise interfere with the project's continuation except as set forth in this paragraph.</p> <p>In the event of an unanticipated discovery of archaeological materials during construction, the applicant shall retain the services of a qualified professional archaeologist, meeting the Secretary of</p>	<p>If the qualified archaeologist determines that a discovery constitutes a significant resource under CEQA and it cannot be avoided, the Department of Planning and Development Services shall verify that an archaeological data recovery program has been conducted.</p>	Department of Planning and Development Services	During grading and construction	Department of Planning and Development Services			



Table 0.4-1. Mitigation Measures

MM No.	Mitigation Measure	Monitoring Method	Responsible Monitoring Party	Monitoring Phase	Verification/Approval Party	Date Mitigation Measure Verified or Implemented	Location of Documents (Monitoring Record)	Completion Requirement
	<p>the Interior's Standards for a Qualified Archaeologist, to evaluate the significance of the materials prior to resuming any construction-related activities in the vicinity of the find. If the qualified archaeologist determines that the discovery constitutes a significant resource under CEQA and it cannot be avoided, the applicant shall implement an archaeological data recovery program.</p>							
CR-4	<p>Human Remains. If subsurface deposits believed to be human in origin are discovered during construction, all work must halt within a 100-foot radius of the discovery. A qualified professional archaeologist who meets the Secretary of the Interior's Standards for prehistoric and historic archaeology and is familiar with the resources of the region, shall be retained to evaluate the significance of the find, and shall have the authority to modify the no work radius as appropriate, using professional judgment. The following notifications shall apply, depending on the nature of the find:</p> <ul style="list-style-type: none"> If the find includes human remains, or remains that are potentially human, the professional archaeologist shall ensure reasonable protection measures are taken to protect the discovery from disturbance (AB 2641). The archaeologist shall notify the Imperial County Coroner (per § 7050.5 of the Health and Safety Code). The provisions of § 7050.5 of the California Health and Safety Code, § 5097.98 of the California PRC, and AB 2641 will be implemented. If the Coroner determines the remains are Native American and not the result of a crime scene, the Coroner will notify the NAHC, which then will designate a Native American Most Likely Descendant (MLD) for the project (§ 5097.98 of the PRC). The designated MLD will have 48 hours from the time access to the property is granted to make recommendations concerning treatment of the remains. If the landowner does not agree with the recommendations of the MLD, the NAHC may mediate (§ 5097.94 of the PRC). If no agreement is reached, the landowner must rebury the remains where they will not be further disturbed (§ 5097.98 	<p>During grading and construction, discovery of human remains shall result in work stoppage in that area until the coroner and the Native American Heritage Commission are contacted.</p> <p>Work may not resume within the no-work radius until the Imperial County Planning and Development Services Department, through consultation as appropriate, determine that the treatment measures have been completed to their satisfaction.</p>	<p>Department of Planning and Development Services</p>	<p>During grading and construction</p>	<p>Department of Planning and Development Services</p>			

Table 0.4-1. Mitigation Measures

MM No.	Mitigation Measure	Monitoring Method	Responsible Monitoring Party	Monitoring Phase	Verification/Approval Party	Date Mitigation Measure Verified or Implemented	Location of Documents (Monitoring Record)	Completion Requirement
	<p>of the PRC). This will also include either recording the site with the NAHC or the appropriate Information Center, using an open space or conservation zoning designation or easement; or recording a reinvestment document with the county in which the property is located (AB 2641). Work may not resume within the no-work radius until the Imperial County Planning and Development Services Department, through consultation as appropriate, determine that the treatment measures have been completed to their satisfaction.</p>							



Table 0.4-1. Mitigation Measures

MM No.	Mitigation Measure	Monitoring Method	Responsible Monitoring Party	Monitoring Phase	Verification/Approval Party	Date Mitigation Measure Verified or Implemented	Location of Documents (Monitoring Record)	Completion Requirement
Geology and Soils								
GEO-1	<p>Prepare Geotechnical Report(s) as Part of Final Engineering for the Project and Implement Required Measures. Facility design for all project components shall comply with the site-specific design recommendations as provided by a licensed geotechnical or civil engineer to be retained by the project applicant. The final geotechnical and/or civil engineering report shall address and make recommendations on the following:</p> <ul style="list-style-type: none"> • Site preparation • Soil bearing capacity • Appropriate sources and types of fill • Potential need for soil amendments • Structural foundations • Grading practices • Soil corrosion of concrete and steel • Erosion/winterization • Seismic ground shaking • Liquefaction • Expansive/unstable soils <p>In addition to the recommendations for the conditions listed above, the geotechnical investigation shall include subsurface testing of soil and groundwater conditions, and shall determine appropriate foundation designs that are consistent with the version of the CBC that is applicable at the time building and grading permits are applied for. All recommendations contained in the final geotechnical engineering report shall be implemented by the project applicant. The final geotechnical and/or civil engineering report shall be submitted to Imperial County Public Works Department, Engineering Division for review and approval prior to issuance of building permits.</p>	<p>Prior to the issuance of a grading permit, the Imperial County Public Works Department Engineering Division shall review and approve a Final Geotechnical Report and/or Civil Engineering Report.</p>	<p>Department of Planning and Development Services and Imperial County Public Works Department, Engineering Division</p>	<p>Prior to issuance of a grading permit</p>	<p>Department of Planning and Development Services and Imperial County Public Works Department, Engineering Division</p>			

Table 0.4-1. Mitigation Measures

MM No.	Mitigation Measure	Monitoring Method	Responsible Monitoring Party	Monitoring Phase	Verification/Approval Party	Date Mitigation Measure Verified or Implemented	Location of Documents (Monitoring Record)	Completion Requirement	
GEO-2	<p>Paleontological Resources: In the event that unanticipated paleontological resources or unique geologic resources are encountered during ground-disturbing activities, work must cease within 50 feet of the discovery and a paleontologist shall be hired to assess the scientific significance of the find. The consulting paleontologist shall have knowledge of local paleontology and the minimum levels of experience and expertise as defined by the <i>Society of Vertebrate Paleontology's Standard Procedures (2010) for the Assessment and Mitigation of Adverse Impacts to Paleontological Resources</i>. If any paleontological resources or unique geologic features are found within the project site, the consulting paleontologist shall prepare a paleontological Treatment and Monitoring Plan to include the methods that will be used to protect paleontological resources that may exist within the project site, as well as procedures for monitoring, fossil preparation and identification, curation of specimens into an accredited repository, and preparation of a report at the conclusion of the monitoring program.</p>	<p>During grading and construction, discovery of paleontological resources shall result in work stoppage in that area until the Qualified Paleontologist can determine the significance of the find.</p> <p>If any paleontological resources or unique geologic features are found within the project site, the project applicant shall submit a copy of a paleontological Treatment and Monitoring Plan.</p> <p>The project applicant shall submit a copy of the Paleontological Resources Monitoring Report to the Department of Planning and Development Services.</p>	<p>Department of Planning and Development Services</p>	<p>During grading and post ground-disturbing activities</p>	<p>Department of Planning and Development Services</p>				

Hydrology/Water Quality

HYD-1	<p>Prepare SWPPP and Implement BMPs Prior to Construction and Site Restoration. The project applicant or its contractor shall prepare a SWPPP specific to the project and be responsible for securing coverage under SWRCB's NPDES stormwater permit for general construction activity (Order 2008-0009-DWQ). The SWPPP shall identify specific actions and BMPs relating to the prevention of stormwater pollution from project-related construction sources by identifying a practical sequence for site restoration, BMP implementation, contingency measures, responsible parties, and agency contacts. The SWPPP shall reflect localized surface hydrological conditions and shall be reviewed and approved by the appropriate agency prior to commencement of work and shall be made conditions of the contract with the contractor selected to build and decommission the project. The SWPPP shall incorporate control measures in the following categories:</p>	<p>Prior to construction and site restoration, the project applicant or its contractor shall prepare a SWPPP with incorporated control measures as outlined in Mitigation Measure HYD-1; and implement BMPs. Department of Planning and Development Services to verify.</p>	<p>Department of Planning and Development Services</p>	<p>Prior to issuance of a grading permit and site restoration</p>	<p>Department of Planning and Development Services</p>			
-------	--------------------------------------------------------------------------------------------------------------------------------------------------------------------------------------------------------------------------------------------------------------------------------------------------------------------------------------------------------------------------------------------------------------------------------------------------------------------------------------------------------------------------------------------------------------------------------------------------------------------------------------------------------------------------------------------------------------------------------------------------------------------------------------------------------------------------------------------------------------------------------------------------------------------------------------------------------------------------------	-----------------------------------------------------------------------------------------------------------------------------------------------------------------------------------------------------------------------------------------------------------------------------	--------------------------------------------------------	-------------------------------------------------------------------	--------------------------------------------------------	--	--	--



Table 0.4-1. Mitigation Measures

MM No.	Mitigation Measure	Monitoring Method	Responsible Monitoring Party	Monitoring Phase	Verification/Approval Party	Date Mitigation Measure Verified or Implemented	Location of Documents (Monitoring Record)	Completion Requirement
	<ul style="list-style-type: none"> • Soil stabilization and erosion control practices (e.g., hydroseeding, erosion control blankets, mulching) • Sediment control practices (e.g., temporary sediment basins, fiber rolls) • Temporary and post-construction on- and off-site runoff controls • Special considerations and BMPs for water crossings and drainages • Monitoring protocols for discharge(s) and receiving waters, with emphasis place on the following water quality objectives: dissolved oxygen, floating material, oil and grease, potential of hydrogen (pH), and turbidity • Waste management, handling, and disposal control practices • Corrective action and spill contingency measures • Agency and responsible party contact information • Training procedures that shall be used to ensure that workers are aware of permit requirements and proper installation methods for BMPs specified in the SWPPP 							
	<p>The SWPPP shall be prepared by a Qualified SWPPP Practitioner and/or Qualified SWPPP Developer with BMPs selected to achieve maximum pollutant removal and that represent the best available technology that is economically achievable. Emphasis for BMPs shall be placed on controlling discharges of oxygen-depleting substances, floating material, oil and grease, acidic or caustic substances or compounds, and turbidity. BMPs for soil stabilization and erosion control practices and sediment control practices will also be required. Performance and effectiveness of these BMPs shall be determined either by visual means where applicable (i.e., observation of above-normal sediment release), or by actual water sampling in cases where verification of contaminant reduction or elimination, (inadvertent petroleum release) is required to determine adequacy of the measure.</p>							

Table 0.4-1. Mitigation Measures

MM No.	Mitigation Measure	Monitoring Method	Responsible Monitoring Party	Monitoring Phase	Verification/Approval Party	Date Mitigation Measure Verified or Implemented	Location of Documents (Monitoring Record)	Completion Requirement
HYD-2	<p>Incorporate Post-Construction Runoff BMPs into Project Drainage Plan. The project Drainage Plan shall adhere to the County's Engineering Guidelines Manual, IID "Draft" Hydrology Manual, or other recognized source with approval by the County Engineer to control and manage the on- and off-site discharge of stormwater to existing drainage systems. Infiltration basins will be integrated into the Drainage Plan to the maximum extent practical. The Drainage Plan shall provide both short- and long-term drainage solutions to ensure the proper sequencing of drainage facilities and management of runoff generated from project impervious surfaces as necessary.</p> <p>The project's Final Drainage Plan shall adhere to the County's Engineering Guidelines Manual, IID "Draft" Hydrology Manual, or other recognized source with approval by the County Engineer to control and manage the on- and off-site discharge of stormwater to existing drainage systems. The Final Drainage Plan shall provide both short- and long-term drainage solutions to ensure the proper sequencing of drainage facilities and shall include source control and treatment BMPs to adequately treat collected runoff prior to discharge, as necessary.</p>	<p>Post construction, the applicant shall implement a Drainage Plan in accordance with the County and Imperial Irrigation District guidelines for the project site. Department of Planning and Development Services and IID to confirm.</p>	<p>Department of Planning and Development Services</p>	<p>Post construction</p>	<p>Department of Planning and Development Services and IID</p>			

Attachment E
CUP 20-0020

RESOLUTION NO.

A RESOLUTION OF THE PLANNING COMMISSION OF THE COUNTY OF IMPERIAL, CALIFORNIA, RECOMMENDING APPROVAL TO THE BOARD OF SUPERVISORS FOR “ VEGA SES 4 SOLAR ENERGY STORAGE PROJECT” FOR CONDITIONAL USE PERMIT #20-0020”

WHEREAS, APEX ENERGY SOLUTIONS, LLC has submitted an application for Conditional Use Permit (CUP) #20-0020 to develop a nominal 100-megawatt (MW) solar photovoltaic (PV) energy generation project with an integrated battery storage system not to exceed 200 MW. The project includes solar energy generation facility, battery storage system, switching station and gen-tie line. The project is to be located on approximately 450 acres;

WHEREAS, an Environmental Impact Report and CEQA Findings have been prepared in accordance with the requirements of the California Environmental Quality Act, the State Guidelines, and the County’s “Rules and Regulations to Implement CEQA,” as Amended;

WHEREAS, the Planning Commission of the County of Imperial has been delegated with the responsibility of approvals, certifications and making recommendations to the Imperial County Board of Supervisors for approvals of conditional use permits;

WHEREAS, public notice of said application has been given, and the Planning Commission has heard, received and considered all oral and written protests, objections and evidence presented by interested parties at a public hearing held with respect to this item on May 24, 2023, and

WHEREAS, the Draft EIR was received by the State Clearinghouse on November 22, 2022 and circulated for a period of 50 days (**SCH #2021050018**) with the commenting period ending January 10, 2023.

NOW, THEREFORE, the Planning Commission of the County of Imperial **DOES HEREBY RESOLVE** as follows:

SECTION 1. The Planning Commission has considered the proposed Conditional Use Permit #20-0020 prior to recommending approval and the County’s consideration of the Project has been noticed in compliance with law.

SECTION 2. That the Project complies with the requirements of the Imperial County Code and is in accordance with State Planning and Zoning law therefore, the following findings are made pursuant to Imperial County Code § 90203.09 as follows:

A. The proposed use is consistent with goals and policies of the adopted County General Plan. (Imperial County Code § 90203.09.A)

The current General Plan land use designations of the project site and proposed parcels are “Agriculture” and proposed project parcels are within the Renewable Energy Overlay (RE). Therefore, the proposed uses could be found consistent with the General Plan.

B. The proposed use is consistent with the purpose of the zone or sub-zone within which the use will be used. (Imperial County Code § 90203.09.B)

The proposed project parcels are zoned A-2-RE. (General Agriculture with Renewable Energy Overlay). The proposed uses are consistent with the zone since they are listed as allowed uses under the A-2 RE zone with an approved Conditional Use Permit.

C. The proposed use is listed as a use within the zone or sub-zone or is found to be similar to a listed conditional use according to the procedures of Section 90203.00. (Imperial County Code § 90203.09.C)

The proposed use is consistent with the zone: A-2-RE (General Agriculture with Renewable Energy Overlay).

D. The proposed use meets the minimum requirements of this Title applicable to the use and complies with all applicable laws, ordinances and regulation of the County of Imperial and the State of California. (Imperial County Code § 90203.09.D)

The Project complies with the minimum requirements of this Title by, among other things, obtaining a CUP, complying with the California Environmental Quality Act, and participating in the public review and hearing process. Development standards have been established for the Project pursuant to these processes, and will be enforced via imposition and enforcement of the Mitigation Monitoring and Reporting Program recommended for approval by separate Resolution, as well as the conditions of approval imposed on this CUP. The Conditions of Approval will further insure that the project complies with all applicable regulations of the County

of Imperial and the State of California. Therefore, the proposed project meets the minimum requirements of the Land Use Ordinance, Section 90203.00.

E. The proposed use will not be detrimental to the health, safety, and welfare of the public or to the property and residents in the vicinity. (Imperial County Code § 90203.09.E)

The Environmental Impact Report (EIR) prepared for the Project analyzed the Project's potential effects on the health, safety, and welfare of the public and property and found that, with mitigation, the Project would have less than significant effects and impacts in all resources areas.

In addition, the project site is not near a residential community and is mostly surrounded by farmland and or open space/recreational land.

F. The proposed use does not violate any other law or ordinance. (Imperial County Code § 90203.09.F)

The proposed project will be subject to the Conditional Use Permit and current Federal, State and Local regulations. State Planning and Zoning Law (Cal. Govt. Code §§ 65000-66035) establishes minimum statewide standards for the regulation of local land use through planning and zoning. The County regulates local land use via Title 9 of the Imperial County Code. As found above, the proposed project is conditioned to be consistent with Imperial County, Title 9, Land Use Ordinance and CEQA mitigation measures and therefore complies with both State and local laws and ordinance.

Pursuant to CEQA, the County has prepared an EIR for the Project, which analyzes the proposed Project's compliance and consistency with other federal, state, and local laws and ordinances regulating the environment. Substantial evidence supports the conclusions in the EIR that the Project complies with said environmental laws, and thus the finds that the proposed use does not violate any other law or ordinance.

G. The proposed use is not granting a special privilege. (Imperial County Code § 90203.09.G)

The proposed solar generating and storage facility is a permitted use subject to approval of the proposed Conditional Use Permit. No special privileges are being offered or will be granted.

SECTION 3. Approval of the Project is conditioned upon the terms and conditions set forth in the Agreement for Conditional Use Permit #20-0020 attached hereto and incorporated herein by this reference.

NOW, THEREFORE, based on the above findings, the Imperial County Planning Commission **DOES HEREBY RECOMMEND APPROVAL** of Conditional Use Permit #20-0020 to the Board of Supervisors, subject to the attached Conditions of Approval.

Rudy Schaffner, Chairperson
Imperial County Planning Commission

I hereby certify that the Planning Commission at a meeting conducted on **May 24, 2023** by the following vote approved the preceding resolution:

AYES:
NOES:
ABSENT:
ABSTAIN:

ATTEST:

Jim Minnick, Director of Planning & Development Services
Secretary to the Planning Commission

S:\AllUsers\APN\059 300 015\ cup20-0020\PCfolder\ CUP Resolution.docx

1 When Recorded Return To:

2 _____
3 Imperial County
3 Planning & Development Services
4 801 Main Street
4 El Centro, California 92243
5 _____

6
7 **AGREEMENT FOR CONDITIONAL USE PERMIT #20-0020**
8 **VEGA SES 4 SOLAR ENERGY STORAGE PROJECT**
9 **APN's 059-300-015 and 059-300-017-000**
10

11 This Agreement is made and entered into on this ____day of _____, 2023, by and
12 between APEX ENERGY SOLUTIONS, LLC hereinafter referred to as the Permittee
13 (Permittee), and the COUNTY OF IMPERIAL, a political subdivision of the State of
14 California (County or Imperial County), related to the VEGA SES 4 SOLAR ENERGY
15 STORAGE PROJECT (CUP #20-0020) project area.

16 **RECITALS**

17 **WHEREAS**, Permittee is the lessee or successor-in-interest of certain land in
18 Imperial County to be improved with the proposed utility-scale solar and battery storage
19 facility. The project, Conditional Use Permit (CUP or Permit) #20-0020, consists of a
20 proposed 100-megawatt (MW) photovoltaic solar energy facility, energy (battery) storage
21 facility (up to 200 MW and not to exceed a 1 to 2 solar/battery ratio) and associated
22 infrastructure, including but not limited to, electrical switch station, substation, on-site
23 operations and maintenance (O&M), a gen-tie line and internal solar development
24 transmission lines, on approximately 450 acres within Imperial County (the "Project"). The
25 proposed facility is located south of the All American canal and north of the International
26 Boundary with Mexico, east of the City of Calexico.

27 **WHEREAS**, Permittee has applied to the County of Imperial for CUP #20-0020 for
28 constructing and operating a new 100 MW solar energy facility, energy (battery) storage
29 facility (up to 200 MW and not to exceed a 1 to 2 solar/battery ratio) with ancillary support
30 facilities, including electrical interconnections. The Project will connect to the existing IID
31 "P" line located immediately north of the project site north of the All American Canal.

32 **WHEREAS**, the Project is located on APNs 059-300-015 and 059-300-017-000 that
33 are contiguous to each other. Project is 10 miles east of the City of Calexico in Sections
34 10, 11, 14, 15 and 16 within Township 17 South and Range 16 East of the SBBM of the
35 Bonds Corner topographic 7.5 minute quadrangle. The project site is located entirely
36 within the Imperial County Renewable Energy Overlay zone.

1
2
3
4
5
6
7
8
9
10
11
12
13
14
15
16
17
18
19
20
21
22
23
24
25
26
27
28

WHEREAS, The Permittee for the VEGA SES 4 Solar Energy Project (CUP #20-0020) shall fully comply with all of the terms and conditions of the Project as specified hereinafter within this CUP.

The rest of this page is intentionally left blank.

1 **GENERAL CONDITIONS:**

2 The "GENERAL CONDITIONS" are shown by the letter "G". These conditions are conditions that are
3 either routinely and commonly included in all Conditional Use Permits as "standardized conditions"
4 and/or are conditions that the Imperial County Planning Commission has established as a requirement
5 on all CUP's for consistent application and enforcement. The Permittee is hereby advised that the
6 General Conditions are as applicable as the SITE SPECIFIC conditions. The General Conditions are in
7 addition to the MMRP and any and all other requirements for the project.

6 **G-1 GENERAL LAWS:**

7 The Permittee shall obtain, comply with and maintain all applicable County, State,
8 and federal laws, rules, regulations, ordinances, and/or standards as they may
9 pertain to this project whether specified herein or not.

9 **G-2 EFFECTIVE DATE:**

10 The approved Conditional Use Permit shall not become effective until ten (10)
11 calendar days after the decision of the Planning Director or Commission. Further
12 the Conditional Use Permit shall not be effective until applicable conditions have
13 been met, and the Conditional Use Permit is recorded with the County Recorder,
14 with payment of recording fees being paid by applicant. In the case of a decision by
15 the Board of Supervisors there is no 10-day appeal.

14 **G-3 RECORDATION:**

15 CUP #20-0020 shall **not be effective** until it is recorded at the Imperial County
16 Recorder's Office and if no appeal has been made after approval from the hearing
17 body. Payment of the recordation fee shall be the responsibility of the Permittee. If
18 this CUP is not recorded within one hundred eighty (180) days from the date of
19 approval the CUP shall be deemed null and void, without notice having to be
20 provided to Permittee. Permittee may submit a written request for a recordation
21 extension for this CUP by filing such a request with the Planning Director at least
22 sixty (60) days prior to the one hundred eighty 180-day expiration. The Director may
23 approve one (1) extension for a period not to exceed one hundred eighty (180)
24 days. An extension may not be granted if the request for an extension is filed after
25 the expiration date. Failure to record this CUP within one (1) year including the
26 granted extension period shall deem this CUP null and void.

23 **G-4 COMMENCEMENT OF WORK:**

24 If the project for which a CUP has been approved has not commenced, or permits
25 for said project have not been issued, within one (1) year from effective date, the
26 CUP shall be null and void. If an applicant cannot initiate or obtain permits for the
27 approved use during the one (1) year, applicant may request a one (1) year
28 extension from the Department. The request for an extension shall be in writing and
be submitted with explanation to the Planning & Development Services Department
at least sixty days prior to the end of the extended one (1) year period. The Director
shall have the authority to extend the initial start-up period, or commencement of
work, of a CUP up to two (2) times for a maximum of two (2) years. Should the

1 Permitee desire to continue with the project, a new application shall be submitted
2 and the entire process would have to begin anew.

3 **G-5 TIME LIMIT:**

4 Unless otherwise specified within the Site Specific Conditions, this Permit shall be
5 limited to a maximum of thirty (30) years from the recordation of the CUP. The CUP
6 may be extended for an additional ten (10) year period by the appropriate County
7 entity (either the Planning Director, the Planning Commission or the Board of
8 Supervisors as set forth in the applicable Imperial County Ordinances) upon a
9 finding that the Project is in compliance with all conditions of the CUP as stated
10 herein and any applicable Land Use regulation of the County of Imperial. In order to
11 obtain an extension, the Permitee shall file a written extension request with the
12 Planning Director at least sixty (60) days prior to the expiration date of the permit.
13 Such an extension request shall include the appropriate extension fee. Nothing
14 stated or implied within this Permit shall constitute a guarantee that an extension
15 will be granted. An extension may or may not be granted if the Project is in violation
16 of any one or all of the conditions or if there is a history of non-compliance with the
17 Permit conditions.

13 **G-6 ABANDONMENT:**

14 If a CUP has been unused, abandoned, discontinued, or ceased for one (1) year,
15 the CUP shall be null and void, and be of no effect. Notice to applicant/permitee
16 under this division will not be required or provided by Department.

16 **G-7 PERMIT/LICENSE:**

17 Permitee shall obtain and comply with any and all required permits, licenses,
18 and/or approvals, for the construction and/or operation of this project. This shall
19 include, but shall NOT be limited to, permits from the County Division of
20 Environmental Health Services (EHS), Planning & Development Services
21 Department, Office of Emergency Services (OES), Imperial County Air Pollution
22 Control District (ICAPCD) and Public Works Department. Permitee shall likewise
23 comply with all such permit requirements for the life of the project. **Additionally,**
24 **Permitee shall submit a copy of such additional permit(s) and/or license(s) to**
25 **the Planning & Development Services Department within 60-days of receipt,**
26 **including amendments or alternatives thereto.**

24 **G-8 APPROVALS AND CONDITIONS SUBSEQUENT TO GRANTING PERMIT:**

25 Permitee acceptance of this CUP shall be deemed to constitute agreement with
26 the terms and conditions contained herein. Where a requirement is imposed in this
27 CUP that Permitee conduct a monitoring program, and where the County has
28 reserved the right to impose or modify conditions with which the Permitee must
comply based on data obtained therefrom, or where the Permitee is required to
prepare specific plans for County approval and disagreement arises, the Permitee,
operator and/or agent, the Planning and Development Services Director or other
affected party, to be determined by the Planning and Development Services

1 Director, may request that a hearing be conducted before the Imperial County
2 Planning Commission whereby they may state the requirements which will
3 implement the applicable conditions as intended herein. Upon receipt of a request,
4 the Planning Commission shall conduct a hearing and make a written
5 determination. The Planning Commission may request support and advice from a
6 technical advisory committee. Failure to take any action shall constitute
7 endorsement of staff's determination with respect to implementation.

8
9 **G-9 CONDITION PRIORITY:**

10 This project shall be constructed/operated as described in the CUP application, the
11 environmental documents, the project description, and as specified in these
12 conditions. Where a conflict occurs, the CUP conditions shall govern.

13
14 **G-10 INDEMNIFICATION:**

15 As part of this application, applicant and real party in interest, if different, agree to
16 defend, indemnify, hold harmless, and release the County of Imperial ("County"), its
17 agents, officers, attorneys, and employees (including consultants) from any claim,
18 action, or proceeding brought against any of them, the purpose of which is to
19 attack, set aside, void, or annul the approval of this application or adoption of the
20 environmental document which accompanies it. This indemnification obligation
21 shall include, but not be limited to, damages, costs, expenses, attorney fees, or
22 expert witness fees that may be asserted by any person or entity, including the
23 applicant, arising out of or in connection with the approval of this application,
24 whether or not there is concurrent negligence on the part of the County, its agents,
25 officers, attorneys, or employees (including consultants).

26 If any claim, action, or proceeding is brought against the County, its agents,
27 officers, attorneys, or employees (including consultants), to attack, set aside, void,
28 or annul the approval of the application or adoption of the environmental document
which accompanies it, then the following procedures shall apply: The Planning
Director shall promptly notify the County Board of Supervisors of any claim, action
or proceeding brought by an applicant challenging the County's action. The
County, its agents, attorneys and employees (including consultants) shall fully
cooperate in the defense of that action. The County shall have the final
determination on how to best defend the case and will consult with applicant
regularly regarding status and the plan for defense. The County will also consult
and discuss with applicant the counsel to be used by County to defend it, either
with in-house counsel, or by retaining outside counsel provided that the County
shall have the final decision on the counsel retained to defend it. Applicant shall be
fully responsible for all costs incurred. Applicant shall be entitled to provide his or
her own counsel to defend the case, and said independent counsel shall work with
County Counsel to provide a joint defense.

G-11 INSURANCE:

The Permittee shall take out and maintain workers compensation insurance as
required by the State of California. The Permittee shall also secure liability

1 insurance and such other insurance as required by state and/or federal law. A
2 Certificate of Insurance is to be provided to the Planning and Development
3 Services Department by the insurance carrier, and said insurance and certificate
4 shall be kept current for the life of the project. Certificates of Insurance shall be
5 sent directly to the Planning and Development Services Department by the
insurance carrier and shall name the Department as a recipient of both renewal and
cancellation notices.

6 **G-12 RIGHT OF ENTRY:**

7 The County reserves the right to enter the premises at any time, announced or
8 unannounced, in order to make the appropriate inspection(s) and to determine if
9 the condition(s) of this CUP are complied with. Access by authorized enforcement
agency personnel shall not be denied.

10 **G-13 SEVERABILITY:**

11 Should any condition(s) of this CUP be determined by a Court or other agency with
12 proper jurisdiction to be invalid for any reason, such determination shall not
13 invalidate the remaining provision(s) of this CUP.

14 **G-14 PROVISION TO RUN WITH LAND:**

15 The provisions of this CUP are to run with the land/project and shall bind the
16 current and future owner(s) successor(s) of interest; assignee(s) and/or
17 transferee(s) of said CUP. **Permittee shall not without prior notification to the
18 Planning & Development Services Department assign, sell, or transfer, or
19 grant control of CUP or any right or privilege therein.** The Permittee shall
provide a minimum of 60 days written notice prior to such proposed transfer
becoming effective. The permitted use identified herein is limited for use upon this
parcel described herein and may not be transferred to another parcel.

20 **G-15 COMPLIANCE/REVOICATION:**

21 Upon the determination by the Planning & Development Services Department that
22 the project is or may not be in full compliance with any one or all of the conditions of
23 this CUP, or upon the finding that the project is creating a nuisance as defined by
24 law, the issue shall be brought immediately to the appropriate enforcement agency
25 or to the Planning Commission for hearing to consider appropriate response
26 including but not limited to the revocation of the CUP or to consider possible
amendments to the CUP. The hearing shall be held upon due notice having been
provided to the Permittee and to the public in accordance with established
ordinance/policy.

27 **G-16 NON-COMPLIANCE (ENFORCEMENT & TERMINATION):**

28 Should the Permittee violate any condition herein, the County shall give written
notice of such violation and actions required of Permittee to correct such violation.
If Permittee does not act to correct the identified violation within forty-five (45) days

1 after written notice, County may revoke the CUP. If Permittee pursues correction of
2 such violation with reasonable diligence, the County may extend the cure period.
3 Upon such revocation, County may, at its sole discretion, cease processing,
4 defending any lawsuit or paying for costs associated with the Project.

4 **G-17 COSTS:**

5 Permittee shall pay any and all amounts determined by the County to defray any
6 and all cost(s) for the review of reports, field investigations, monitoring, and other
7 activities directly related to the enforcement/monitoring for compliance of this CUP,
8 County Ordinance or any other applicable law. Any billing against this project, now
9 or in the future, by the Planning & Development Services Department or any
County Department for costs incurred as a result of this CUP, shall be billed
through the Planning & Development Services Department.

10 **G-18 REPORT(S)**

11 Permittee shall file an annual report with the Planning and Development Services
12 Department to show that Permittee is in full compliance with this CUP. The report
13 shall be filed at least fifteen (15) days prior to the anniversary (recordation date) of
14 this CUP. It shall be the responsibility of the Permittee to provide all reports and to
15 include the information about other users. The County may request information at
16 any time from the Permittee or other users if applicable; however, it shall be the
17 responsibility of the Permittee to assure that the County receives such information
18 in a timely manner.

16 **G-19 RESPONSIBLE AGENT**

17 Permittee shall maintain on file with the Planning and Development Services
18 Department the name and phone number of the responsible agent for the site. A
19 back-up name shall also be provided, and a phone number for twenty-four (24)
20 hour emergency contact shall also be on file. If there are other users, the same
21 information (as applicable) required from the Permittee shall also be made available
22 to the County from such other users.

22 **G-20 WATER AND SEWER:**

23 Permittee shall provide water and sewer to Federal, State and County standards.
24 Water and sewer systems shall be approved by the Environmental Health Services
25 and the Planning & Development Services Department. Permittee shall hook up to
a public water system or supplier if and when available.

26 **G-21 DEFINITIONS:**

27 In the event of a dispute, the meaning(s) or the intent of any word(s) phrase(s)
28 and/or conditions or sections herein shall be determined by the Planning
Commission of the County of Imperial. Their determination shall be final unless an
appeal is made to the Board of Supervisors ten (10) days from the date of their
decision.

1
2 **G-22 SPECIFICITY:**

3
4 The issuance of this CUP does not authorize the Permittee to construct or operate
5 this project in violation of any state, federal, local law nor beyond the specified
6 boundaries of the project as shown in the application/project description/ CUP, nor
7 shall this CUP allow any accessory or ancillary use not specified herein. This CUP
8 does not provide any prescriptive right or use to the Permittee for future addition
9 and/or modification to this project.

10 **G-23 HEALTH HAZARD:**

11 If the County Health Officer determines that a significant health hazard exists to the
12 public, the County Health Officer may require appropriate measures and the
13 Permittee shall implement such measures to mitigate the health hazard. If the
14 hazard to the public is determined to be imminent, such measures may be imposed
15 immediately and may include temporary suspension of the subject operations.
16 However, within forty five (45) days of any such suspension of operations, the
17 measures imposed by the County Health Officer must be submitted to the Planning
18 Commission for review and approval. Nothing shall prohibit Permittee from
19 requesting a special Planning Commission meeting provided Permittee bears all
20 costs.

21 **G-24 CHANGE OF OWNER/OPERATOR:**

22 In the event the ownership of the site or the operation of the site transfers from the
23 current Permittee to a new successor Permittee, the successor Permittee shall be
24 bound by all terms and conditions of this CUP as if said successor was the original
25 Permittee. Current Permittee shall inform the County Planning & Development
26 Services Department in writing at least sixty (60) days prior to any such transfer.
27 Failure of a notice of change of ownership or change of operator shall be grounds
28 for the immediate revocation of the CUP. In the event of a change, the new
Owner/Operator shall file with the Department, via certified mail, a letter stating that
they are fully aware of all conditions and acknowledge that they will adhere to all.

G-25 PERMITS OF OTHER AGENCIES INCORPORATED:

Permits granted by other governmental agencies in connection with the Project are
incorporated herein by reference. The County reserves the right to apply conditions
of those permits, as the County deems appropriate; provided, however, that
enforcement of a permit granted by another governmental agency shall require
concurrence by the respective agency. Permittee shall provide to the County, upon
request, copies and amendments of all such permits.

G-26 MINOR AMENDMENTS:

The Planning Director may approve minor changes or administrative extensions, as
requested in writing by the Permittee, provided it does not result in additional
environmental impacts and/or are generally procedural or technical and/or which

1 may be necessary to comply with other government permit compliance
2 requirements.

(TOTAL "G" CONDITIONS are 26)

3
4
5
6 **SITE SPECIFIC CONDITIONS:**

7 **S-1 AUTHORIZED SCOPE OF ACTIVITIES:**

- 8 (A) Permittee shall be responsible as for all improvements, septic, sewer,
9 approved potable water system(s), pipelines, roads and other
10 improvements discussed in the CUP Application and Conditions of
11 Approval, FEIR, and MMRP. If Permittee sells all or part of this Project,
12 an approved agreement shall be in place for new Project owner to build
13 and maintain as agreed to by the conditions set forth in this CUP.
14 Additionally, the County Assessor's Office shall be notified of any
15 ownership change.
- 16 (B) Permittee shall develop this Project per approved CUP as a separate
17 solar energy and energy (battery) storage facility. Any development with
18 a combination of parcels will require the owner(s) to have a recorded
19 deed restriction to "hold the parcel as one parcel" that runs with the
20 land, or at Permittee's option merge the parcels. This deed restriction
21 shall be for a minimum of thirty (30) years and shall only be released
22 upon the expiration of the thirty (30) years, the expiration or termination
23 of the CUP, or upon approval of the Imperial County Planning and
24 Development Director that the restriction is no longer needed based on
25 a change in the development or regulation.
- 26 (C) The Permittee shall construct and operate the solar energy and energy
27 (battery) storage facility in compliance with the CUP, the County's
28 General Plan's Land Use Element, Land Use Ordinance and all other
applicable local, state, and federal LORS, to include any other permits
which are incorporated herein by reference.
- (D) Construction, operation, maintenance, replacement and removal of a
solar energy facility & energy (battery) storage system shall be as
described in Permittee's CUP Application and previously approved
FEIR for the Vega SES 4 Solar Energy project (CUP #20-0020), to
include photovoltaic (PV) modules, mounting structures, electrical
wiring, inverters, transformers and alternating current (AC) electric
collector system, project electric substation and ancillary facilities.
Ancillary facilities include safety and security equipment, retention
basins, perimeter fencing, access gates, lighting systems, access
roads, and may include temporary construction trailers, equipment
enclosures, water treatment system and building, septic system,

1 parking, and fire protection. The Project's PV arrays shall be comprised
2 of solar PV panels organized into electrical groups referred to as
3 "blocks." The panels shall be oriented from east to west for maximum
4 sun exposure and the foundation shall be designed based on soil
5 conditions. The PV panels are made of a poly-crystalline silicon
6 semiconductor material encapsulated in glass. Installation of the PV
7 arrays includes installation of mounting posts, module rail assemblies,
8 PV modules, inverters, transformers and buried electrical conductors.
Concrete is required for the footings, foundations and pads for the
transformers and substation work. Tracker foundations shall be
comprised of either driven or vibrated steel posts/pipes, and/or concrete
in some places (depending on soil and underground conditions).

- 9 (E) The Project's energy (battery) storage (BESS) component will be
10 located on a concrete pad at the northeastern edge of the project site,
11 unless final engineering design and/or IID requirements require a
12 different location.

13 The BESS will consist banks of batteries and will be supported by a DC
14 Combiner, control panel, and inverter/transformer skid. Each enclosure
15 will include built-in fire suppression systems. The batteries will be
16 lithium-ion based and capable of storing up to 200 MW in total (not to
exceed 200 MW. These racks would be integrated into containers or be
self-contained in engineered systems such as for example the Tesla
Mega Pack. The Project design would meet minimum spacing required
by code and manufacturers specifications.

17 **S-2 AESTHETICS:**

- 18 (A) The Permittee shall design and maintain all buildings and equipment
19 enclosures to have exterior surfaces with neutral, non-reflective colors.
- 20 (B) The Permittee shall design and install lighting at construction storage
21 yards and staging areas, such that light bulbs and reflectors are not
22 visible from public viewing areas; lighting does not create reflected
glare; and illumination of the Project facilities, vicinity, and nighttime sky
is minimized.
- 23 (C) Lighting shall be designed so exterior light fixtures are hooded, with
24 lights directed downward or toward the area to be illuminated and so
25 that backscatter to the nighttime sky is minimized. The design of the
26 lighting shall be such that the luminescence or light source is shielded
to minimize light trespass outside the Project boundary.
- 27 (D) All lighting shall be of minimum necessary brightness consistent with
28 worker safety and OSHA requirements.
- (E) High illumination areas not occupied on a continuous basis shall have
switches or motion detectors to light the area only when occupied.

1
2 **S-3 AGRICULTURE:**

3
4 (A) Compensation for loss of Farmland included below shall be
5 implemented prior to the issuance of a grading permit or building permit
(whichever is issued first) for the Project:

- 6 1. Voluntarily enter into a public benefit agreement at an annual
7 fee cost for the Public Service Benefit of \$600 per acre year.
8 2. Costs associated with the per acre payment shall be annually
9 adjusted on January 1st to add a Consumer Price Index (CPI)
10 increase, as determined by the United States Bureau of Labor
11 Statistics, but in no case shall such increase be less than zero
12 (0).

13 (B) Permittee shall minimize paving and ground disturbing activities to the
14 maximum extent practical within agricultural fields to retain soil
15 characteristics.

16 (C) Pest Management Plan. Prior to the issuance of a grading permit or
17 building permit (whichever occurs first), a Pest Management Plan shall
18 be developed by the Permittee and approved by the County of Imperial
19 Agriculture Commissioner. The Permittee shall maintain a Pest
20 Management Plan until reclamation is complete. The Plan shall provide
21 the following:

- 22 1. Monitoring, preventative, and management strategies for weed
23 and pest control during construction activities at any portion of the
24 project (e.g., transmission line);
25 2. Control and management of weeds and pests in areas temporarily
26 disturbed during construction where native seed will aid in site
27 revegetation as follows:
28
 - Monitor for all pests including insects, vertebrates, weeds, and
pathogens. Promptly control or eradicate pests when found, or
when notified by the Agricultural Commissioner's office that a
pest problem is present on the project site. The assistance of a
licensed pest control advisor is recommended.
 - All treatments must be performed by a qualified applicator or a
licensed pest control operator;
 - "Control" means to reduce the population of common pests
below economically damaging levels, and includes attempts to
exclude pests before infestation, and effective control methods
after infestation. Effective control methods may include
physical/mechanical removal, bio control, cultural control, or
chemical treatments;

- Use of “permanent” soil sterilants to control weeds or other pests is prohibited because this would interfere with reclamation;
- Notify the Agricultural Commissioner’s office immediately regarding any suspected exotic/invasive pest species as defined by the California Department of Food Agriculture and the U.S. Department of Agriculture. Request a sample be taken by the Agricultural Commissioner’s Office of a suspected invasive species. Eradication of exotic pests shall be done under the direction of the Agricultural Commissioner’s Office and/or California Department of Food and Agriculture.

S-4 AIR QUALITY:

- (A) The Permittee shall comply at all times with the ICAPCD Regulation VIII, Fugitive Dust Control. Please use MMRP for guidance.
- (B) Prior to commencing construction, the Permittee shall submit a Dust Control Plan to the ICAPCD for approval identifying all sources of PM₁₀ emissions and associated mitigation measures during the construction and operational phases of the Project. The Project Proponent shall submit a “Construction Notification Form” to the ICAPCD ten (10) days prior to the commencement of any earthmoving activity. The Dust Control Plan submitted to the ICAPCD shall meet all applicable requirements for control of fugitive dust emissions, including the following measures designed to achieve the no greater than 20% opacity performance standard for dust control:
 - (1) All on-site and off-site unpaved roads shall be effectively stabilized, and visible emissions shall be limited to no greater than 20% opacity for dust emissions by paving, chemical stabilizers, dust suppressants, and/or watering.
 - (2) All unpaved traffic areas one acre or more in size with seventy-five (75) or more average vehicle trips per day, shall be effectively stabilized, and visible emissions shall be limited to no greater than 20% opacity for dust emissions by paving, chemical stabilizers, dust suppressants and/or watering.
 - (3) The transport of bulk materials shall be completely covered, unless six inches of freeboard space from the top of the container is maintained with no spillage and loss of bulk material. In addition, the cargo compartment of all haul trucks shall be cleaned and/or washed at the delivery site after removal of bulk material.
 - (4) All track-out or carry-out, which includes bulk materials that adhere to the exterior surfaces of motor vehicles and/or equipment (including tires) that may then fall onto the pavement, shall be cleaned at the end of each workday, or immediately when mud or

1 dirt extends a cumulative distance of fifty (50) linear feet or more
2 onto a paved road within an urban area.

3 (5) Movement of bulk material handling or transfer shall be stabilized
4 prior to handling, or at points of transfer with application of
5 sufficient water, chemical stabilizers, or by sheltering or enclosing
6 the operation and transfer line.

6 (6) The construction of new unpaved roads is prohibited within any
7 area with a population of five hundred (500) or more, unless the
8 road meets ICAPCD's definition of a "temporary unpaved road."
9 Any temporary unpaved road shall be effectively stabilized and
10 visible emissions shall be limited to no greater than 20% opacity
11 for dust emission by paving, chemical stabilizers, dust
12 suppressants and/or watering.

11 (7) Shall comply with the MMRP's and its applicable mitigations.

12 (C) The Permittee shall implement all applicable standard mitigation
13 measures for construction combustion equipment for the reduction of
14 excess NOx emissions as contained in the Imperial County CEQA Air
15 Quality Handbook and associated regulations. These measures
16 include:

15 (1) Use of alternative fueled or catalyst equipped diesel construction
16 equipment, including all off-road and portable diesel-powered
17 equipment.

17 (2) Minimize idling time, either by shutting equipment off when not in
18 use or reducing the time of idling to five minutes at a maximum.

18 (3) Limit the hours of operation of heavy-duty equipment and/or the
19 amount of equipment in use.

19 (4) Replace fossil-fueled equipment with electrically driven equivalents
20 (assuming powered by a portable generator set and are available,
21 cost effective, and capable of performing the task in an effective,
22 timely manner).

21 (5) Curtail construction during periods of high ambient pollutant
22 concentrations; this may include ceasing construction activity
23 during the peak hour of vehicular traffic on adjacent roadways.

23 (6) Implement activity management (e.g. rescheduling activities to
24 avoid overlap of construction phases, which would reduce short-
25 term impacts).

26
27
28
S-5 GEOLOGY/SOILS and MINERAL RESOURCES:

- 1 (A) Prior to approval of final engineering and grading plans for the Project,
2 the County shall verify that all recommendations contained in the
3 Geotechnical Report for this Solar Facility and have been incorporated
4 into all final engineering and grading plans. The County's soil engineer
and engineering geologist shall review grading plans prior to finalization
to verify compliance with the recommendations of the report.

5 **S-6 CULTURAL RESOURCES:**

- 6 (A) Compliance and Monitors shall insure all mitigations set forth in the
7 MMRP are followed.

8 **S-7 HEALTH, SAFETY AND HAZARDOUS MATERIAL/FIRE AND FUELS**
9 **MANAGEMENT:**

- 10 (A) All trash and debris within the Project site shall be disposed of off-site,
11 in accordance with current, local, state, and federal disposal
12 regulations. Compliance with this measure shall be verified by the
Planning and Development Services Department.

- 13 (B) If it is determined that hazardous wastes are, or will be generated by
14 the proposed operations, the wastes must be managed in accordance
15 with the California Hazardous Waste Control Law (California Health and
16 Safety Code, Division 20, Chapter 6.5) and the Hazardous Waste
Control Regulations (California Code of Regulations, Title 22, Division
4.5).

- 17 (C) If it is determined that hazardous wastes will be generated, the
18 Permittee should also obtain a United States Environmental Protection
19 Agency, Identification Number by contacting (800) 618-6942. Certain
20 hazardous waste treatment processes or hazardous material, handling,
21 storage or uses may require authorization from the local Certified
Unified Program Agency (CUPA). Information about the requirement for
authorization can be obtained by contacting the local CUPA.

- 22 (D) Firearms shall be prohibited in all Project areas except for those used
23 by licensed security personnel.

- 24 (E) The recognized environmental concerns shall be cleaned up and
25 properly disposed of in accordance with all federal, state and local
regulations.

- 26 (F) Any hazardous materials storage areas shall be designed with curbs or
27 other containment measures, e.g., double-walled storage tanks, to
28 contain spills and leaks. If on-site hazardous materials exceed fifty-five
(55) gallons, a "Hazardous Material Management Plan" shall be
prepared and approved by the County Local Enforcement Agency
(LEA) and the Imperial County CUPA. A copy of the approved plan
shall be submitted to ICPDSD prior to the issuance of the

1 grading/building permit (Source: Imperial County Renewable Energy
2 Ordinance, Title 9, Division 17, § 91702.00).

- 3 (G) The Permittee shall present to the Department an Emergency
4 Response/Action Plan that has been approved by the ICFD/OES
5 Department, and the LEA and any other agencies with jurisdiction
6 (Source: Imperial County Renewable Energy Ordinance, Title 9,
7 Division 17, § 91702.00).

8 The Emergency Response/Action Plan shall cover all possible
9 foreseeable emergencies, e.g., major fluid spills, earthquakes, fires,
10 floods or other emergencies. At all times, there shall be at least one
11 employee either on the facility premises or on-call (i.e., available to
12 respond to an emergency by reaching the facility within a short period of
13 time) with the responsibility to coordinate all emergency response
14 measures. This Emergency Coordinator shall be thoroughly familiar
15 with all aspects of the Project's Emergency Response/Action Plan, all
16 operations and activities at the facility, location of all records within the
17 facility and the facility's layout. This Emergency Coordinator shall have
18 the authority to commit the resources needed to carry out the
19 contingency plan. Adequate personnel and equipment shall be
20 available to respond to emergencies and to ensure compliance with the
21 conditions of the Permit.

22 The Emergency Response/Action Plan shall be prepared in
23 consultation with, but not be limited to, the ICFD/OES, County
24 EHS/Health Department, County Sheriff/Coroner's office, County
25 Department of Public Works, ICPDSD, and other appropriate state and
26 county agencies. The plan shall include a notification list of response
27 agencies which shall be notified immediately upon the discovery of a
28 reportable unauthorized discharge and the list shall include:

- 29 - ICFD/OES;
- 30 - ICPDSD;
- 31 - County EHS/Health Department;
- 32 - County Department of Public Works; and
- 33 - California Highway Patrol, as applicable.

34 All employees shall be trained by classroom and hands-on training on
35 safety procedures, maintenance programs and emergency response
36 protocols to ensure safety and reliability in the event of an unforeseen
37 emergency situation.

38 The Permittee shall provide adequate safety devices to protect against
the hazard of fire and explosion for activities that involve the use and
storage of flammable, explosive or highly corrosive or reactive materials
as well as provide adequate firefighting and fire suppression equipment
and using devices standard within the industry in compliance with all
applicable state and local laws as determined by the ICFD/OES.

1
2
3
4
5
6
7
8
9
10
11
12
13
14
15
16
17
18
19
20
21
22
23
24
25
26
27
28

The Permittee shall implement all State and County-approved worker safety and fire protection plans and programs.

Any gates on-site shall have a “Knox” lock rapidly accessible by the ICFD/OES.

Appropriate first aid provisions for facility operations shall be made for emergency response during Project construction, operation, and maintenance activities with appropriate first aid training for Project employees.

During construction, a member of each working crew shall be trained in basic first aid and supplied with necessary medical equipment to respond to emergencies as provided for in the Emergency Response/Action Plan required above.

Permittee shall identify a responsible agent for emergency purposes, whose name, title, e-mail address and telephone number shall be provided to the County Department of Public Works, ICFD/OES, County Environmental Health Services/Health Department, County Sheriff/Coroner’s office, IID, and ICPDSD.

S-8 HYDROLOGY AND WATER QUALITY:

Adhere to measures set forth in the MMRP.

S-9 BIOLOGICAL RESOURCES:

Adhere to all Biological measures in the MMRP

S-10 PUBLIC SERVICES:

(A) The Permittee shall widely publicize to County residents the availability of job opportunities associated with the Project (whether or not those job opportunities are within Imperial County or are regional). Postings at City Halls, newspaper and television advertisements, local job centers, and dedicated website shall offer sufficient avenues of communication. The Imperial County Office of Employment and Training in addition to the Imperial Valley College presents viable sources for community awareness. The information shall provide available positions, details of positions including qualifications, number of openings, indicated the anticipated start date for each, and application process. In order to maintain oversight of the process, the application process can be completed both on a dedicated website and at dedicated computers at the County which would afford those without Internet connection the ability to apply. The Permittee’s information shall be forwarded to the Permittee or their contractor and copies of applications files are maintained at the County.

- 1 (B) During the development phase of the Project, the Permittee shall provide a roster of
2 employees to include their position and place of residence.
- 3 (C) Unless prohibited by local, state or federal law or regulation, Permittee shall make
4 good faith efforts to hire qualified residents of the Imperial County with the objective
5 that a majority of the total work force is comprised of the Imperial County residents.
- 6 (D) The Permittee shall install and implement security measures which may include,
7 but not limited to, secured perimeter fencing with barbed wire, sensors, controlled
8 access points, security alarms, security camera systems, and security guard vehicle
9 patrols to deter trespass or unauthorized activities that would interfere with
10 operation of the Project.
- 11 (E) Permittee shall compensate the County pursuant to the Department of
12 Environmental Health Fee Schedule for any costs of calls related to bees and
13 mosquitoes.
- 14 (F) The Permittee shall reimburse the Sheriff's Department for any investigations
15 regarding theft on the Project site and related law enforcement.
- 16 (G) All construction supervisors and foremen shall be provided with communication
17 devices, cell phones or walkie-talkies, in the event of an emergency situation on-
18 site.
- 19 (H) All construction-related activities shall take place within the development footprint of
20 the Project as defined by the final engineering plans. The anticipated impact areas,
21 including staging areas, equipment access, and disposal or temporary placement of
22 spoils, shall be delineated with staking and/or orange construction fencing prior to
23 construction to avoid natural resources where possible. No construction-related
24 activities shall occur outside of the designated impact area. All construction
25 materials, staging, storage, dispensing, fueling, and maintenance activities shall be
26 designated on construction maps and shall be situated a minimum of fifty (50) feet
27 from all drainages. Staging and temporary access shall occur on existing roadways
28 whenever possible.
- (I) **Emergency Operations Plan** - The Applicant shall develop an Emergency
Operation Plan in conjunction with local fire service personnel and the AHJ and
hold a comprehensive understanding of the hazards associated with lithium-ion
battery technology. Lithium-ion battery energy storage systems must incorporate
adequate explosion prevention protection as required in NFPA 855 or International
Fire Code Chapter 12, where applicable.
- (J) **Signage** - The Applicant shall provide signage that identifies the contents of an
energy storage system on all energy storage system installations to alert first
responders to the potential hazards associated with the installation.

S-11 TRANSPORTATION AND TRAFFIC:

1 A. Permittee shall prepare and submit a Construction Traffic Control
2 Plan to Imperial County Department of Public Works-Development
3 Review and Caltrans District 11, as appropriate, for approval. The
4 Construction Traffic Control Plan must be prepared in accordance
5 with both the California Department of Transportation Manual on
6 Uniform Traffic Control Devices and Work Area Traffic Control
7 Handbook and must include, but not be limited to, the following
8 issues:

- 9 1. Timing of deliveries of heavy equipment and building
10 materials;
- 11 2. Directing construction traffic with a flag person;
- 12 3. Placing temporary signing, lighting, and traffic control
13 devices if required, including, but not limited to, appropriate
14 signage along access routes to indicate the presence of
15 heavy vehicles and construction traffic;
- 16 4. Ensuring access for emergency vehicles to the Project site;
- 17 5. Temporarily closing travel lanes or delaying traffic during
18 materials delivery, transmission line stringing activities, or
19 any other utility connections;
- 20 6. Maintaining access to adjacent property;
- 21 7. Specifying both construction-related vehicle travel and
22 oversize load haul routes, minimizing construction traffic
23 during the AM and PM peak hours, distributing construction
24 traffic flow across alternative routes to access the Project
25 site, and avoiding residential neighborhoods to the maximum
26 extent feasible.

27 B. Permittee shall Institute construction work hours as necessary, such
28 that the arrival and/or departure times of workers would be staggered
as necessary.

C. Permittee shall identify vehicle safety procedure for entering and
exiting site access roads.

D. Permittee shall submit documentation that identifies the roads to be
used during construction.

E. The Permittee shall be responsible for repairing any damage to non-
County maintained roads that may result from construction activities.
The Permittee shall submit a preconstruction video log and inspection
report regarding roadway conditions for roads used during
construction to the Imperial County Department of Public Works
Within 30 days of completion of construction, the project
proponent/operator shall submit a post-construction video log and
inspection report to the County. This information shall be submitted in
electronic format. The County, in consultation with the Permittee's
engineer, shall determine the extent of remediation required, if any.

1
2 **S-12 COMMENCEMENT OF WORK:**

- 3 (A) If the Project has not commenced, or permits for the Project have not
4 been issued, within one (1) year from approval date this CUP shall be
5 null and void. If this CUP has been unused, abandoned, discontinued,
6 or ceased for one (1) year, it shall be null and void and of no effect.
7 (B) If Permittee cannot initiate or obtain permits for the approved use during
8 the one (1) year period following approve of this CUP, Permittee may
9 request a one (1) year extension from the ICPDSD. The request for an
10 extension shall be in writing and be submitted with explanation to the
11 ICPDSD at least sixty (60) days prior to the end of the one (1) year
12 period. The Director shall have the authority to extend the initial startup
13 period of a CUP two times for a maximum of one (1) year each. No
14 extension under this section shall be extended for more than two (2)
15 years.

16 **S-13 CONSTRUCTION STANDARDS:**

- 17 (A) The solar energy and energy (battery) storage facility structures shall
18 be built in accordance with the California Building Code requirements
19 applicable to "Seismic Category D". All structures and facilities shall be
20 designed in accordance with the publication entitled "Recommended
21 Lateral Force Requirements and Commentary by the Structural
22 Engineers Association of California". The structural components of the
23 permitted facilities shall be reviewed by the Building Official/Planning
24 and Development Services Director. Applicable building permits shall be
25 procured from the County for facilities prior to commencement of
26 construction of such facilities.

27 **S-14 LAND USE IMPROVEMENTS:**

- 28 (A) The Permittee shall prepare an appropriate parking plan for review
and approval by the ICPDSD and County Public Works Department
for any and/or all proposed Operation & Maintenance buildings.
(B) The Permittee shall surface with a material of higher quality all access
drives, parking areas, and vehicular maneuvering areas from primary
access to any constructed operation and maintenance buildings.

S-15 NOISE STANDARDS:

- (A) During the construction period, heavy truck traffic shall be limited to
the hours between 6:00 AM and 7:00 PM.
(B) During construction, in accordance with Imperial County Noise
Element of the General Plan, the noise level shall not exceed 75
dBA_{Leq} at the property boundary when averaged over an 8-hour
period.

- 1
- 2 (C) During operation of the facility, the maximum permitted continuous
- 3 sound level shall be not more than 45 dBA_{Leq}, as measured at the
- 4 nearest residence using the "A" scale and measured with a sound
- 5 level meter and associated octave band analyzer. The level may be
- 6 exceeded by ten percent (10%) if the noise is intermittent and during
- 7 daylight hours.
- 8 (D) Haul trucks and other engine-powered equipment shall be muffled and
- 9 operated with engine exhaust brake use limited to emergencies.

10

11

12

13 **S-16 ODOR CONTROL:**

14 The Permittee shall control all odor-causing, harmful, noxious emissions to

15 ensure that quantities or air contaminants released as a result of the

16 permitted facilities do not exceed County, State or Federal standards, nor

17 constitute a public nuisance, per the Imperial County Land Use Ordinance,

18 Division 13, Enforcement, Chapter 2, Abatement of Nuisances, Sections

19 91302.00 through 91301.02.

20 **S-17 PLAN APPROVALS:**

21 Permittee shall submit to the ICPDSD, architectural, landscaping and lighting

22 plans prior to construction of those facilities, to include painting of structures,

23 planting of trees and/or vegetation, and shall receive all approvals prior to

24 commencing construction of the applicable permitted facilities. Approval

25 shall not be unreasonably withheld so long as the plans are consistent with

26 applicable Imperial County Land Use Ordinance requirements.

27 **S-18 PROJECT DESIGN:**

- 28 (A) All facility access and parking areas shall be constructed to the
- standards of the Imperial County Land Use Ordinance.
- (B) All permitted activities shall provide for the minimum feasible surface
- land disturbance for compatibility with the existing uses wherever
- possible.
- (C) All equipment and electrical interconnection facilities used at the solar
- plant facilities shall be maintained in a manner that prevents breaking,
- cracking, and leaking, e.g. operator staffing and training, including
- appropriate quality assurance procedures, with the operation of back-up
- or auxiliary facilities when necessary.
- (D) All on-site basins shall be designed and constructed under the
- supervision of a California-licensed Civil Engineer meeting sound
- engineering standards, with all applicable regulations and all

1 requirements of the County EHS/Health Department and Public Works
2 Departments are complied with.

- 3 (E) Permittee shall obtain encroachment permits for any construction or
4 operation on IID existing rights of way or easements.

5 **S-19 REPORTING AND MONITORING:**

- 6 (A) The Permittee shall furnish to the County, at its sole cost within a
7 reasonable time, any relevant reports/information which the County
8 requires for monitoring purposes to determine whether cause exists for
9 revoking this Permit, or to determine compliance with this Permit. The
10 Permittee shall submit all required reports to the Planning Director,
11 County Planning and Development Services Department, 801 Main
12 Street, El Centro, CA 92243.
- 13 (B) Permittee and ICPDSD Director shall agree upon an environmental
14 consultant for overseeing all the required mitigation, conditional use
15 Permit conditions and public benefit agreement (if any) requirements
16 during the construction of the Project.
- 17 (C) Permittee shall pay for third-party environmental consultant monitoring
18 and compliance.
- 19 (D) The ICPDSD, in consultation with the third-party Environmental
20 Consultant and the County Executive Office, will require that all
21 mitigation measures be satisfied, all MMRP requirements have been
22 satisfied, all Conditions of Approval in the CUP are in full compliance
23 and all conditions of the Development Agreement (if any) have been
24 satisfied before the Final Certificate of Occupancy Certificate is issued.
- 25 (E) During the operation of solar facility, an Annual Compliance Report
26 shall be submitted to the ICPDS, documenting the implementation of
27 the conditions and general measures as well as any resource-specific
28 measures.
- (F) The Permittee shall reimburse the ICPDS for County as well as
monitoring and investigations related to the construction and operation
of the Project. Permittee shall compensate the County pursuant to the
ICPDSD Fee Schedule for any costs incurred.
- (G) Permittee shall pay for all costs as required to comply with the
Conditions of Approval and MMRP.
- (H) All County staff time will be billed on a time and materials basis. Failure
by Permittee to provide any payment required of Permittee to the
County in the CUP shall cause Permittee to be in non-compliance of
the CUP. Upon notice of such noncompliance, County may, at its sole
discretion, cease processing, defending any lawsuit or paying for costs

1
2
3
4
5
6
7
8
9
10
11
12
13
14
15
16
17
18
19
20
21
22
23
24
25
26
27
28

associated with the Project.

S-20 SPILLS AND RUNOFF:

The Permittee shall design and construct the permitted facilities to prevent spills from endangering adjacent properties and to prevent runoff from any source being channeled or directed in an unnatural way so as to cause erosion, siltation, or other detriments pursuant to the construction Storm Water Pollution Prevention Plan approved by the Regional Water Quality Control Board.

S-21 FACILITIES CLOSURE AND SITE RESTORATION:

- (A) Permittee shall implement the site restoration plan at the earlier of when the operation of the permitted facilities herein authorized has ceased or the term of the CUP has expired. At such time, all facilities shall be dismantled, and the lands involved restored to their pre-construction condition and available for agricultural production uses as agreed to by the Imperial County Planning and Development Services Director.
- (B) Prior to the issuance of a grading Permit, a decommissioning and restoration plan (the Reclamation Plan) shall be submitted and approved by the Imperial County Planning and Development Services Director. The Reclamation Plan shall documents the procedures by which the Project site will be returned to its current conditions.
- (C) Within thirty (30) days prior to ground disturbance, a Bond, or other acceptable surety, in the amount of the estimated site restoration financial calculations/bond, for the developed project area, or other forms of security acceptable to County Counsel's office, shall be filed with the County that guarantees restoration of the land to its condition prior to the permitted solar plant development.
- (D) Upon completion of such site restoration, and demonstration that the land has been restored to the agriculturally productive/farmable condition prior to the permitted solar plant development the Bond or other surety shall be released by the County.
- (E) The above financial calculations/bond shall be reviewed every five (5) years in December and adjusted on January 1st to add a Consumer Price Index (CPI) (Los Angeles) increase by the Planning and Development Services Director. This readjustment can be made in the County's sole discretion and must be funded by the Permittee within ninety (90) calendars after notice of the additional amount of such adjustment.

1
2 **S-22 PUBLIC WORKS:**

- 3 1. The Applicant shall acquire proper easements from adjacent property owners for the
4 installation of any proposed transmission lines.
- 5 2. All survey monuments, including those within the interior of the project, shall be
6 protected, and their locations shall remain accessible to any surveyor throughout the
7 duration of the project. Section 8774 of the Business and Professions Code, and
8 Section 846.5 of the Civil Code, each provide the right of entry to utilize boundary
9 evidence and perform surveys, without undue delay, to any person authorized to
10 practice land surveying. The right of entry is not contingent upon prior notice.
- 11 3. The Applicant shall furnish a Drainage and Grading Plan/Study to provide for property
12 grading and drainage control, which shall also include prevention of sedimentation of
13 damage to off-site properties. The Study/Plan shall be submitted to the Department
14 of Public Works for review and approval. The applicant shall implement the approved
15 plan. Employment of the appropriate Best Management Practices (BMP's) shall be
16 included (Per Imperial County Code of Ordinances, Chapter 12.10.020 B).
- 17 4. Based from the information provided on the project documents, it is assumed that
18 County roads will not be used for site access during or after construction activities
19 have been completed. In the event that County roads are required for site access,
20 the Applicant shall consult with this Department in advance for review and approval.

21 Access to sites shall be completed from public roads.

- 22 5. Any unimproved access roads/routes between public roads and access gates shall
23 be improved for all-weather access. Such all-weather improvements shall be
24 completed as recommended by a Geotechnical Engineer licensed to practice in the
25 State of California.
- 26 6. Each site shall have, as a minimum, one (1) primary Class 2 Base aggregate material
27 driveway and one (1) emergency access Class 2 Base aggregate material driveway,
28 if they are tied to a County Road only.
7. Access to project sites during and after construction is expected to be completed
through private unpaved roads or private property.

**The Applicant shall mitigate generation of dust caused by construction traffic
as per Rule 805 – Paved and Unpaved Roads of the Imperial County Air
Pollution Control District.**

- All solid and hazardous waste shall be disposed of in approved solid waste disposal sites in accordance with existing County, State and Federal regulations (Per Imperial County Code of Ordinances, Chapter 8.72).
- All on-site traffic areas shall be hard surfaced to provide all weather access for emergency vehicles. The surfacing shall meet the Department of Public Works and

1 Fire/Office of Emergency Services (EOS) Standards as well as those of the Air
2 Pollution Control District (APCD).

- 3 • The project may require a National Pollutant Discharge Elimination System
4 (NPDES) permit and Notice of Intent (NOI) from the Regional Water Quality Control
5 Board (RWQCB) prior to County approval of onsite grading plan (40 CFR 122.28).
- 6 • A Transportation Permit may be required from road agency(s) having jurisdiction
7 over the haul route(s) for any hauls of heavy equipment and/or large vehicles
8 which impose greater than legal loads on riding surfaces, including bridges. (Per
9 Imperial County Code of Ordinances, Chapter 10.12 - OVERWEIGHT VEHICLES
10 AND LOADS).
- 11 • Effective September 15, 2020, the State's Mandatory Organic Waste Recycling
12 Law (AB 1826 or Chapter 727, Statutes of 2014) decreased the threshold requiring
13 all businesses and multi-dwelling facilitates of 5 units or more generating two (2)
14 cubic yards or more of solid waste per week to recycle their organic waste
15 including landscape waste, wood waste, and food waste. Information about
16 possible organics waste recycling services can be found at the CalRecycle site at:
17 <https://www.calrecycle.ca.gov/Recycle/Commercial/Organics/>

14 **S-23 WASTE DISPOSAL**

- 15 (A) The Permittee shall insure that all solar plant facilities waste, liquid, gas
16 or solid, which are generated on-site shall be disposed of in compliance
17 with appropriate local, state, and federal regulations, in effect or as
18 subsequently duly-enacted. All solid waste debris and/or any
19 hazardous wastes located on the Project site must be satisfactorily
20 removed to a permitted facility prior to the commencement of grading
21 earthen material at the site.
- 22 (B) Littering shall not be allowed. Project personnel shall not deposit or
23 leave any food or waste in the Project area, and no biodegradable or
24 non-biodegradable debris shall remain in the right-of-way or on the
25 Project site following completion of construction.

23 **S-24 CALTRANS:**

- 24 (A) An encroachment permit shall be required for any work performed
25 within any Caltrans right-of-way. If required, any traffic control will need
26 to be addressed as part of Caltrans permit approval in accordance with
27 the Caltrans Standard Plans and the California Manual on Uniform
28 Traffic Control Devices (MUTCD).
- (B) Any application for a permit for work performed within a Caltrans right-
of-way must include an approved final environmental document
including the California Environmental Quality Act (CEQA)
determination addressing any environmental impacts within the

1 Caltrans right-of-way and any corresponding technical studies, if
2 required. If these materials are not included with the encroachment
3 permit application, the Permittee will be required to acquire and provide
4 these to Caltrans before the permit application will be accepted.
5 Identification of avoidance and/or mitigation measures will be a
6 condition of encroachment permit approval as well as procurement of
7 any necessary regulatory and resource agency permits.

- 6 (C) Any work performed within Caltrans' Right of Way (R/W) will require
7 discretionary review and approval by Caltrans. As part of the
8 encroachment permit process, the applicant must provide an approved
9 final environmental document, corresponding technical studies, and
10 necessary regulatory and resource agency permits, specifically, any
11 CEQA determinations or exemptions.

10 **S-25 IID Condition requirements**

11 (A) The Project may impact IID drains with project site runoff flows draining
12 into IID drains. To mitigate impacts, IID may require a comprehensive
13 IID hydraulic drainage system analysis. IID's hydraulic drainage system
14 analysis includes an associated drain impact fee.

15 (B) An IID encroachment permit is necessary to utilize existing surface-
16 water drainpipe connections to drains and receive drainage service from
17 IID. Surface-water drainpipe connections are to be modified in
18 accordance with IID standards. A construction storm-water permit from
19 the California Regional Water Quality Control Board is required before
20 commencing construction and an industrial storm water permit from
21 CRWQCB is needed for the operation of the proposed facility. Copies of
22 these permits as well as the project's Storm Water Pollution Prevention
23 Plan are to be submitted to IID.

20 **S-26 FIRE PROTECTION:**

21 Energy storage facilities create extreme hazards for firefighters and emergency
22 responders with possibility of explosions, flammable gases, toxic fumes, water-
23 reactive materials, electrical shock, corrosives, chemical burns. The hazards
24 listed can create a potential significant impact on Imperial County Fire
25 Department due personnel staffing to safely perform firefighting operations and
26 Hazardous Material Response for a utility-scale energy storage facility. The
27 location of the project will lead to longer response times. These longer response
28 times can create incidents that can create difficulties in incident stabilization;
therefor requiring additional personnel to safety manage the incident. Utility-
scale energy storage will require specialized and reliable equipment to perform
firefighting operations safely and effectively to NFPA, OSHA and ICFD standards
and requirements.

Standards and requirements for energy storage system includes but not limited
to:

NFPA:

1 1 Fire Code
2 70 National Electrical Code
3 855 Standard for the installation of Energy Storage System
4 111 Stored Electrical Energy Emergency and Standby Power System
5 1710 Standard for Organization and Deployment of Fire Suppression
6 Operations, Emergency Medial Operations, and Special Operations to the
7 Public by Career Fire Departments.

8 OSHA:
9 29 CFR 1910.134(g)(4)

10 CFC:
11 Chapter 12 section 1206 Electrical Energy Storage System
12 Chapter 9 Fire Protection and Life Safety System.

- 13 1) Vega Solar Energy and Storage Project reviews for plans and inspections
14 will be done by a third-party consultant determined by the Fire Department
15 at the applicant's expense as per California Fire Code Chapter 1 [A]
16 104.7.2 Technical Assistance. This will be at the discretion of the Fire
17 Department.
- 18 2) Project will cooperate in the purchase of a Fire Engine "As further
19 described below" within the prior agreement that Vega 2, Vega 3, Vega 5
20 and Viking will purchase one Engine.. This is for the solar array and
21 battery storage. The fire engine cost estimate will be at current market
22 value for the approved Fire Engine. Final cost, conditions and equipment
23 of the fire engine shall be determined prior to the issuance of the initial
24 grading permit. This fire engine will be fair shared cost with other solar
25 projects on the southeast portion of the Imperial County.
- 26 3) Project will provide adequate Fire water. Fire Department will determine
27 number of gallons to be placed strategically once site plan is reviewed.
- 28 4) This payment shall be made before issuance of the first building permit for
the Project, or for each phase of the Project, whichever is applicable.
- 5) Signage that identifies the contents of an ESS is required on all ESS
installations to alert first responders to the potential hazards associated
with the installation.
- 6) Fire- In lieu of providing all-weather access roads for fire protection
vehicles, the permittee shall be permitted to provide compacted native soil
(in compliance with ICAPCD's rules and regulations) for fire protection
vehicles if prior to the issuance of any grading permit for the Project shall
purchase a Type 1 Fire Engine as specified and approved by the Fire
Department.

1
2
3
4
5
6
7
8
9
10
11
12
13
14
15
16
17
18
19
20
21
22
23
24
25
26
27
28

- 7) The County agrees to require, as a condition of approval, other developers in the area to reimburse the Applicant for the expenses associated with the purchase of the Type 1 Fire Engine.
- 8) The Permittee shall be reimbursed only for those expenses more than their proportionate share for the purchase of the Fire Engine that the Permittee would have been required to pay. Furthermore, if a Type 1 Fire Engine was already purchased by another developer in the area, then the Permittee shall only be required to pay a fire mitigation in the amount of up to \$100 per acre that would represent their proportionate share to reimburse the purchaser of the Type 1 Fire Engine.
- 9) The County shall be responsible for managing the reimbursement component of condition 15 above of approval.
- 10) An approved water supply capable of supplying the required fire flow determined by appendix B in the California Fire Code shall be installed and maintained. Private fire service mains and appurtenance shall be installed in accordance with NFPA 24.
- 11) An approved automatic fire suppression system shall be installed on all structures as per the California Fire Code. All fire suppression systems will be installed and maintained to the current adapted fire code and regulations.
- 12) An approved automatic fire detection system shall be installed on all structures as per the California Fire Code. All fire detection systems will be installed and maintained to the current adapted fire code and regulations.
- 13) Fire department access roads and gates will be in accordance with the current adapted fire code and the facility will maintain a Knox Box for access on site.
- 14) Compliance with all required sections of the fire code.
- 15) Applicant shall provide product containment areas(s) for both product and water run-off in case of fire applications and retained for removal.
- 16) All hazardous material and wastes shall be handled, store, and disposed as per the approved Hazardous Waste Materials Plan. All spills shall be documented and reported to Imperial County Fire Department and CUPA as required by the Hazardous Waste Material Plan.

1 **S-27 COUNTY EXECUTIVE OFFICE:**

- 2 **I.** Fiscal and Economic Impact Analysis. The Permittee will be invoiced by the
3 Executive Office for expenses related to the procurement of a consultant to
4 produce an updated Fiscal and Economic Impact Analysis (FEIA).
- 5 **II.** Public Benefit Agreement (PBA). It will include detailed conditions & measures
6 related to the Fire Department, Sheriff’s Department and other County
7 Departments.
- 8 **III.** The Public Benefit Fee may include both an Agricultural Benefit Fee and a
9 Community Benefit Fee.

10 **IV. Sales Tax Benefit Solar Farm:**

- 11 (a) Developer will require that all qualifying contractors and subcontractors exercise
12 their option to obtain a California Department of Tax and Fee Administration
13 (CDTFA) sub-permit for the jobsite and allocate all eligible use tax payments to
14 Imperial County and LTA. Prior to commencement of any construction activity
15 on-site the developer will require that the contractor or subcontractor provide
16 County of Imperial with either a copy of their CDTFA account number and sub-
17 permit.
- 18 (b) To accomplish this, Permittee shall either cause its construction contractor to
19 treat the project in accordance with California Regulation 1521(b)(2)(B),
20 California Regulation 1521(c)(13)(B), and California Regulation 1826(b) for
21 sales and use tax purposes or form a “Buying Company” as defined in the
22 CDTFA 1699(h). Permittee can adopt an alternate methodology to accomplish
23 this goal if such methodology is approved by the County Executive Officer prior
24 to issuance of building permits. Not later than forty five (45) days after the due
25 date for filing sales and use tax returns for each calendar quarter, occurring
26 after the commencement of any construction activity on-site through and
27 including the first anniversary of COD (as defined below),
- 28 (c) Developer shall report, or cause its general contractor to report to County, the
 total amount of sales and use taxes related to the Project that are allocated to
 the County, and reported on Developer’s, general contractor’s, and
 subcontractors’ applicable California sales and use tax returns. The obligations
 of Developer under this Section III.A are hereinafter referred to as the
 “Developer Sales and Use Tax Responsibilities.”
- (d) Guarantee Amounts. In the event that Developer shall fail to perform the
 Developer Sales and Use Tax Responsibilities and as a result of such failure,
 with respect to the Project, (i) County receives less than the amount of such
 sales and use taxes it would have received under existing applicable sales and
 use tax laws had such responsibilities been fully performed subject to
 adjustment as set forth in Section IV.C below) or (ii) Local Transportation
 Authority (LTA) receives less than the amount of such sales and use taxes it
 would have received under existing applicable sales and use tax laws had such
 responsibilities been fully-performed, then Developer shall pay, as and when
 provided below, to County or LTA as applicable, the amount of the applicable
 shortfall.

- 1 (e) Adjustments to Guarantee Amounts.
- 2 (f) Developer's sales tax guarantee set out in Section III.B above shall be adjusted
- 3 to be eighty-five percent (85%) of the projected sales and use taxes for the
- 4 Project. At least ten (10) days prior to the issuance of the first (1st) grading
- 5 permit, Developer shall provide County with evidence of such projected sales
- 6 and use taxes, including but not limited to sales taxes receipts, engineering
- 7 contracts, procurement contracts, construction contracts. County shall meet
- 8 with Developer to confirm that amount.
- 9 (g) The amount of sales and use tax anticipated to be generated is based on the
- 10 projected construction of a one hundred megawatt alternating current 100 MW
- 11 AC solar generation facility. Construction of any additional output capacity
- 12 beyond the 100 MW output now projected will require the sales tax guarantee
- 13 be adjusted based on the actual output from solar generation facilities of the
- 14 Project as evidenced by any Power Purchase Agreement subsequently entered
- 15 into by Developer related to this Project.
- 16 (h) To the extent of any reduction in the size of the Project as the result of any final
- 17 ruling, stipulated judgment, or settlement, in accordance with Section V.C
- 18 below, the not-to-exceed amounts set forth in Section III.B shall be reduced pro
- 19 rata based on the size of such reduction.
- 20 (i) The complete amount due to County for the Project must be received within
- 21 one (1) year after Commercial Operation Date ("COD") for this Project. If,
- 22 within one (1) year after issuance of the final Certificate of Occupancy, the
- 23 sales and use taxes received by the County are less than the amount
- 24 guaranteed for that portion of the project, Developer shall pay the difference to
- 25 the County.
- 26 (j) Payments to County and LTA as a result of a shortfall shall be due within thirty
- 27 days of Developer's receipt of written notice of shortfall from the County.
- 28 Payments received by County after the ninetieth (90th) day following
- Developer's receipt of notice shall be deemed late. Developer hereby agrees
- to pay interest at the rate of six percent (6%) per annum of the payment due for
- any payment received by County beyond the due date. Said interest shall be
- included with the late payment. The obligation to pay interest shall be stayed
- when such amounts are disputed in good faith, so long as Developer submits
- the payments "under written protest." Upon determination of dispute, such
- interest may be assessed if it is determined that the dispute was not made in
- good faith.
- (k) In the event that Developer repowers or replaces the equipment onsite, each
- Site shall be designated as the "Point of Sale" so as to create an additional
- local tax-funding source for the County of Imperial.

V. Battery Storage Sales Tax Benefit

- 1.1.1. To the extent permitted by applicable local, state, and Federal law, Developer will require that all qualifying contractors and subcontractors exercise their option to obtain a California Department of Tax and Fee Administration ("CDTFA") sub-permit for the jobsite and allocate all eligible sales and use tax payments to County and the Local Transit Authority ("LTA").

1 1.1.2. Prior to commencement of any construction activity onsite exclusive of grading,
2 , Developer shall require that the contractor or subcontractor provide County
3 with a copy of their CDTFA account number and sub-permit. Developer shall
4 either cause its construction contractor to treat the Project in accordance with
5 California Sales and Use Tax Regulation 1521(b)(2)(B), California Sales and
6 Use Tax Regulation 1521(c)(13)(B), and California Sales and Use Tax
7 Regulation 1826(b) for sales and use tax purposes, or form a "Buying
8 Company," as defined in the California Sales and Use Tax Regulation 1699(h).
9 Developer may adopt an alternate methodology to accomplish this goal if such
10 methodology is approved by the County's Executive Officer prior to issuance of
11 any building permit.

12 1.1.3. No later than forty-five (45) days after the due date for filing sales and use tax
13 returns for each calendar quarter, occurring after the commencement of any
14 construction activity on-site through and including the first anniversary of
15 commercial operating date ("COD"), Developer shall report, or cause its general
16 contractor to report to County, the total amount of sales and use taxes related
17 to the Project that are allocated to the County, and reported on Developer's,
18 general contractor's and subcontractors' applicable California sales and use tax
19 returns.

20 1.1.4. *Guarantee Amounts.* Prior to the issuance of any building permit for the
21 Project, Developer shall provide County with a guarantee of the minimum sales
22 and use that will be received by County and LTA under existing applicable
23 sales and use tax laws. The guarantee amount shall be based on the total
24 storage capacity of the Project in megawatts, which is projected to be two
25 Hundred megawatts (200 Mws) Should Developer choose to develop the
26 Project in phases, and receives the required approvals from County to do so,
27 then Developer shall provide a separate guarantee amount for each phase of
28 the project based on the total storage capacity in megawatts for the applicable
phase.

(a) Developer warrants that the sales/use tax guarantee amounts to be provided to
County as mandated in this Subparagraph 9.2.4 shall be true and accurate
estimates of the projected sales and use taxes that will be generated for this
Project. Developer shall provide County with evidence of the projected
sales/use taxes for the Project, including but not limited to sales tax receipts,
and executed or anticipated engineering contracts, procurement contracts, and
construction contracts. If the Parties are unable to agree upon a guarantee
amount, then the dispute shall be referred to an independent accountant
mutually acceptable to both Parties. The costs for such nonbinding mediation
shall be borne by Developer.

(b) Developer warrants that the sales/use tax guarantee amounts to be provided to
County as mandated in this Subparagraph 9.2.4 will incorporate any and all
sales/use tax exemptions that Developer and/or its contractors and
subcontractors intend to utilize, and that such exemptions will be disclosed to
County fully and in good faith prior to the issuance of any building permit for this
Project.

1 (c) Developer understands and acknowledges that the sales/use tax guarantee
2 amounts to be provided to County as mandated by this Subparagraph 9.2.4 are
3 a part of the consideration to be received by County in return for entering into
4 this Agreement, and further understands and acknowledges that County would
5 not enter into this Agreement but for said guarantee from Developer.

6 **1.1.5.** In the event that County and / or LTA receives less than the amount of
7 sales/use taxes guaranteed pursuant to Subparagraph 9.2.4, then Developer
8 shall pay, as and when provided below, to County or LTA as applicable, the
9 amount of the applicable shortfall.

10 **1.1.6. *Adjustments to Guarantee Amounts.***

11 (a) The amount of sales and use tax anticipated to be generated is based on the
12 projected construction of a 200 MW utility-scale energy storage complex
13 incorporating lithium ion batteries and/or flow battery technologies throughout
14 the Project site. Construction of any additional storage capacity beyond the
15 200 MW storage capacity now projected will require the sales/use tax
16 guarantee amounts to be adjusted based on the actual storage facilities of the
17 Project as evidenced by any power purchase agreement or power storage
18 agreement subsequently entered into by Developer related to this Project.

19 (b) To the extent of any reduction in the size of the Project as the result of any final
20 ruling, stipulated judgment, or settlement, the sales/use tax guarantee amounts
21 mandated under Subparagraph 9.2.4 shall be reduced pro rata based on the
22 size of such reduction.

23 (c) Should Developer become aware of a change in circumstances that would
24 materially affect the sales/use tax guarantee amount, then Developer shall,
25 within thirty (30) days of learning of such change in circumstances, inform the
26 County in writing of the change in circumstances. If the County determines that
27 such change in circumstances warrants an adjustment to the sales/use tax
28 guarantee amount, then County shall negotiate in good faith with Developer in
revising the sales/use tax guarantee amount. If the Parties are unable to agree
upon a revised guarantee amount, then the dispute shall be referred to an
independent accountant mutually acceptable to both Parties. The costs for
such nonbinding mediation shall be borne by Developer. Failure of the
Developer to inform the County of the change in circumstances shall constitute
a waiver of Developer's ability to seek any adjustment to the sales/use tax
guarantee based on such change in circumstances.

1.1.7. The complete sales/use tax guarantee amount due to County and LTA for the
Project must be received within one (1) year after COD for this Project, or such
later date as any applicable sales/use tax is due or is transmitted from the
CDTFA, unless it is delayed due to causes beyond Developer's control or for
which Developer is not responsible. If, within one (1) year after issuance of the
final certificate of occupancy, or such later date as any applicable sales/use tax
is due or is transmitted from the CDTFA, the sales/use taxes received by the
County are less than the sales use tax guarantee amounts mandated under
Subparagraph 9.2.4, then Developer shall pay the difference to the County.

1.1.8. Payments to County and LTA as a result of a shortfall shall be due within thirty
days of Developer's receipt of written notice of shortfall from the County.
Payments received by County after the ninetieth (90th) day following
Developer's receipt of notice shall be deemed late. Developer hereby agrees

1 to pay interest at the rate of six percent (6%) per annum of the payment due for
2 any payment received by County beyond the due date. Said interest shall be
3 included with the late payment. The obligation to pay interest shall be stayed
4 when such amounts are disputed in good faith, so long as Developer submits
5 the payments "under written protest." Upon determination of dispute, such
6 interest may be assessed if it is determined that the dispute was not made in
7 good faith.

- 8 • In the event that Developer repowers or replaces the equipment onsite, each
9 Site shall be designated as the "Point of Sale" so as to create an additional
10 local tax-funding source for the County of Imperial.

11 **S-28 IMPERIAL COUNTY SHERIFF'S OFFICE**

- 12 *I. Prior to issuance of the first building permit the permittee and the Imperial*
13 *County Sheriff's Office will provide to the Planning Director a copy of the*
14 *executed Fair Share Agreement to the following items:*
 - 15 a) Developer shall purchase marked and equipped four-wheel drive patrol
16 vehicle. Final cost, conditions and equipment to be installed on four-wheel
17 drive patrol vehicle shall be reasonably determined by Sheriff's Office, and
18 the total cost of the four-wheel drive Patrol vehicle shall be at current market
19 value.
 - 20 b) Developer shall enter into a specific cost reimbursement agreement for
21 direct police and fire protection services whereas for each call made to the
22 project site for such public safety services that the project is responsible for
23 reimbursing the County of Imperial. Such agreement can be created using
24 a "Contract Cities Service Rate" for both police (Sheriff) and fire protection
25 services.
 - 26 c) Developer shall enter into a specific cost reimbursement agreement
27 for direct judicial and prosecutor services whereas if a person(s) are
28 tried in a court of law for potential crimes at the project site, that the
project itself is required to reimburse the County for such costs.
 - d) Developer shall purchase investigatory field cameras for remote
observation of area. Cameras will assist in identifying and locating
persons or vehicles of interest in the event of criminal activity on, against
or near the property. The cost for four (4) cameras shall be at current
market value.
 - e) Developer shall purchase camera vehicle identifiers and license plate
readers to be placed within the main roadway leading to or from the sites
as this allows tracking and pertinent evidentiary tools to successful
prosecution. The cost shall be at current market value.

1
2
3
4
5
6
7
8
9
10
11
12
13
14
15
16
17
18
19
20
21
22
23
24
25
26
27
28

f) Developer shall purchase Unmanned Aircraft System program, also known as our Drone Program. Resources in equipment and upgraded software to manage oversight of given areas in remote locations would greatly advance the span of oversight ICSO is able to provide. The cost shall be at current market value."

S-29 ACCEPTANCE:

Acceptance of this permit shall be deemed to constitute agreement by Permittee with all terms and conditions herein contained.

The rest of this page is intentionally left blank.

1
2
3
4
5
6
7
8
9
10
11
12
13
14
15
16
17
18
19
20
21
22
23
24
25
26
27
28

NOW THEREFORE, County hereby issues the Conditional Use Permit #20-0020, and Permittee hereby accepts such permit upon the terms and conditions set forth herein.

IN WITNESS THEREOF, the parties hereto have executed this Agreement the day and year first written.

PERMITTEE:

_____ Date _____

COUNTY OF IMPERIAL, a political subdivision of the STATE OF CALIFORNIA

_____ Date _____
Jim Minnick,
Director, Planning & Development Services
Department

1
2
3
4
5
6
7
8
9
10
11
12
13
14
15
16
17
18
19
20
21
22
23
24
25
26
27
28

PERMITTEE NOTARIZATION

A notary public or other officer completing this certificate verifies only the identity of the individual who signed the document to which this certificate is attached, and not the truthfulness, accuracy, or validity of that document.

STATE OF CALIFORNIA

COUNTY OF _____ } S.S.

On _____ before me, _____ a Notary Public in and for said County and State, personally appeared _____, who proved to on the basis of satisfactory evidence to be the person(s) whose name(s) is/are subscribed to the within instrument and acknowledged to me that he/she/they executed the same in his/her/their authorized capacity(ies), and that by his/her/their signature(s) on the instrument the person(s), or the entity upon behalf of which the person(s) acted, executed the instrument.

I certify under PENALTY OF PERJURY under the laws of the State of California that the foregoing paragraph is true and correct.

WITNESS my hand and official seal

Signature _____

ATTENTION NOTARY: Although the information requested below is OPTIONAL, it could prevent fraudulent attachment of this certificate to unauthorized document.

Title or Type of Document _____

Number of Pages _____ Date of Document _____

Signer(s) Other Than Named Above _____

Dated _____

1
2
3
4
5
6
7
8
9
10
11
12
13
14
15
16
17
18
19
20
21
22
23
24
25
26
27
28

COUNTY NOTARIZATION

A notary public or other officer completing this certificate verifies only the identity of the individual who signed the document to which this certificate is attached, and not the truthfulness, accuracy, or validity of that document.

STATE OF CALIFORNIA
COUNTY OF IMPERIAL } S.S.

On _____ before me, _____ a Notary Public in and for said County and State, personally appeared _____, who proved to me on the basis of satisfactory evidence to be the person(s) whose name(s) is/are subscribed to the within instrument and acknowledged to me that he/she/they executed the same in his/her/their authorized capacity(ies), and that by his/her/their signature(s) on the instrument the person(s), or the entity upon behalf of which the person(s) acted, executed the instrument.

I certify under PENALTY OF PERJURY under the laws of the State of California that the foregoing paragraph is true and correct.

WITNESS my hand and official seal

Signature _____

ATTENTION NOTARY: Although the information requested below is OPTIONAL, it could prevent fraudulent attachment of this certificate to unauthorized document.

Title or Type of Document _____

Number of Pages _____ Date of Document _____

Signer(s) Other Than Named Above _____

S:\AllUsers\APN\059\300\015\CUP20-0020\PC FOLDER\CUP 20-0020\CUP W CONDITIONS OF APPROVAL\CUP20-0020 Vega SES 4 05 12 23.doc

Attachment F:

Final EIR

Draft Environmental Impact Report

VEGA SES 4 Solar Energy Project

SCH No. 2021050018

Imperial County, California

November 2022

Prepared for

County of Imperial
801 Main Street
El Centro, California 92243

Prepared by

HDR
591 Camino de la Reina
Suite 300
San Diego, California 92108

This page is intentionally blank.



Table of Contents

Executive Summary	ES-1
Project Overview	ES-1
Purpose of an EIR	ES-1
Eliminated from Further Review in Notice of Preparation	ES-1
Summary of Significant Impacts and Mitigation Measures that Reduce or Avoid the Significant Impacts	ES-2
Areas of Controversy and Issues to be Resolved	ES-2
Project Alternatives	ES-27
Environmentally Superior Alternative	ES-29
1 Introduction	1-1
1.1 Overview of the Proposed Project	1-1
1.1.1 Agency Roles and Responsibilities	1-1
1.2 Relationship to Statutes, Regulations, and Other Plans	1-3
1.2.1 County of Imperial General Plan and Land Use Ordinance	1-3
1.2.2 Renewables Portfolio Standard Program	1-3
1.2.3 Senate Bill 32	1-4
1.2.4 Title 17 California Code of Regulations, Subchapter 10, Article 2, Sections 95100 et seq.	1-4
1.2.5 Federal Clean Air Act	1-4
1.2.6 Imperial County Air Pollution Control District	1-5
1.2.7 Federal Clean Water Act (33 United States Code Sections 1251–1387)	1-5
1.2.8 Federal Clean Water Act and California Porter-Cologne Water Quality Control Act	1-5
1.2.9 Federal Endangered Species Act	1-5
1.2.10 National Historic Preservation Act	1-6
1.2.11 California Endangered Species Act	1-6
1.2.12 California Lake and Streambed Program (Fish and Game Code Section 1602)	1-6
1.3 Purpose of an EIR	1-6
1.4 EIR Process	1-6
1.4.1 Availability of Reports	1-6
1.4.2 Public Participation Opportunities/Comments and Coordination	1-7
1.4.3 Environmental Topics Addressed	1-8
1.4.4 Areas of Controversy and Issues to be Resolved	1-8
1.4.5 Document Organization	1-8
2 Project Description	2-1
2.1 Project Location	2-1
2.1.1 Solar Energy Facility	2-1
2.1.2 Battery Storage System	2-1
2.1.3 Gen-Tie Line	2-4
2.1.4 Renewable Energy Overlay Zone	2-4
2.2 Project Objectives	2-4
2.3 Project Characteristics	2-4
2.3.1 Photovoltaic Panels/Solar Arrays	2-7
2.3.2 Electrical Power System	2-7
2.3.3 Interconnection Facilities	2-7
2.3.4 Gen-Tie	2-8
2.3.5 Battery Energy Storage System	2-8
2.3.6 Security	2-8

2.3.7	Site Access.....	2-9
2.3.8	Fire Protection/Fire Suppression.....	2-9
2.4	Site Construction.....	2-10
2.4.1	Construction Activities.....	2-10
2.4.2	Heavy Construction Equipment Access.....	2-10
2.4.3	Parking and Staging Areas.....	2-10
2.4.4	Water Use.....	2-16
2.5	Operations and Maintenance.....	2-16
2.5.1	Water Use.....	2-16
2.6	Restoration of the Project Site.....	2-16
2.7	Required Project Approvals.....	2-17
2.7.1	Imperial County.....	2-17
2.7.2	Discretionary Actions and Approvals by Other Agencies.....	2-18
2.7.3	Memorandum of Understanding – U.S. Border Patrol.....	2-18
3	Environmental Analysis, Impacts, and Mitigation.....	3.1-1
3.1	Introduction to Environmental Analysis.....	3.1-1
3.1.1	Organization of Issue Areas.....	3.1-1
3.1.2	Format of the Impact Analysis.....	3.1-1
3.2	Aesthetics and Visual Resources.....	3.2-1
3.2.1	Existing Conditions.....	3.2-1
3.2.2	Regulatory Setting.....	3.2-2
3.2.3	Impacts and Mitigation Measures.....	3.2-3
3.2.4	Decommissioning/Restoration and Residual Impacts.....	3.2-7
3.3	Agricultural Resources.....	3.3-1
3.3.1	Existing Conditions.....	3.3-1
3.3.2	Regulatory Setting.....	3.3-1
3.3.3	Impacts and Mitigation Measures.....	3.3-8
3.3.4	Decommissioning/Restoration and Residual Impacts.....	3.3-13
3.4	Air Quality.....	3.4-1
3.4.1	Existing Conditions.....	3.4-1
3.4.2	Regulatory Setting.....	3.4-5
3.4.3	Impacts and Mitigation Measures.....	3.4-11
3.4.4	Decommissioning/Restoration and Residual Impacts.....	3.4-23
3.5	Biological Resources.....	3.5-1
3.5.1	Existing Conditions.....	3.5-1
3.5.2	Regulatory Setting.....	3.5-30
3.5.3	Impacts and Mitigation Measures.....	3.5-34
3.5.4	Decommissioning/Restoration and Residual Impacts.....	3.5-45
3.6	Cultural Resources.....	3.6-1
3.6.1	Existing Conditions.....	3.6-1
3.6.2	Regulatory Setting.....	3.6-10
3.6.3	Impacts and Mitigation Measures.....	3.6-14
3.6.4	Decommissioning/Restoration and Residual Impacts.....	3.6-19
3.7	Geology and Soils.....	3.7-1
3.7.1	Existing Conditions.....	3.7-1
3.7.2	Regulatory Setting.....	3.7-9
3.7.3	Impacts and Mitigation Measures.....	3.7-12
3.7.4	Decommissioning/Restoration and Residual Impacts.....	3.7-18
3.8	Greenhouse Gas Emissions.....	3.8-1
3.8.1	Existing Conditions.....	3.8-1
3.8.2	Regulatory Setting.....	3.8-4



3.8.3	Impacts and Mitigation Measures	3.8-9
3.8.4	Decommissioning/Restoration and Residual Impacts.....	3.8-14
3.9	Hazards and Hazardous Materials.....	3.9-1
3.9.1	Existing Conditions.....	3.9-1
3.9.2	Regulatory Setting.....	3.9-3
3.9.3	Impacts and Mitigation Measures	3.9-7
3.9.4	Decommissioning/Restoration and Residual Impacts.....	3.9-13
3.10	Hydrology/Water Quality	3.10-1
3.10.1	Existing Conditions.....	3.10-1
3.10.2	Regulatory Setting.....	3.10-3
3.10.3	Impacts and Mitigation Measures	3.10-10
3.10.4	Decommissioning/Restoration and Residual Impacts.....	3.10-19
3.11	Land Use Planning	3.11-1
3.11.1	Existing Conditions.....	3.11-1
3.11.2	Regulatory Setting.....	3.11-4
3.11.3	Impacts and Mitigation Measures	3.11-13
3.11.4	Decommissioning/Restoration and Residual Impacts.....	3.11-15
3.12	Noise and Vibration	3.12-1
3.12.1	Existing Conditions.....	3.12-1
3.12.2	Regulatory Setting.....	3.12-8
3.12.3	Impacts and Mitigation Measures	3.12-13
3.12.4	Decommissioning/Restoration and Residual Impacts.....	3.12-19
3.13	Transportation	3.13-1
3.13.1	Existing Conditions.....	3.13-1
3.13.2	Regulatory Setting.....	3.13-3
3.13.3	Impacts and Mitigation Measures	3.13-4
3.13.4	Decommissioning/Restoration and Residual Impacts.....	3.13-9
3.14	Tribal Cultural Resources.....	3.14-1
3.14.1	Existing Conditions.....	3.14-1
3.14.2	Regulatory Setting.....	3.14-1
3.14.3	Impacts and Mitigation Measures	3.14-4
3.14.4	Decommissioning/Restoration and Residual Impacts.....	3.14-6
3.15	Utilities and Service Systems	3.15-1
3.15.1	Existing Conditions.....	3.15-1
3.15.2	Regulatory Setting.....	3.15-1
3.15.3	Impacts and Mitigation Measures	3.15-4
3.15.4	Decommissioning/Restoration and Residual Impacts.....	3.15-5
4	Analysis of Long-Term Effects	4-1
4.1	Growth-Inducing Impacts	4-1
4.2	Significant Irreversible Environmental Changes	4-2
4.3	Unavoidable Adverse Impacts	4-3
5	Cumulative Impacts.....	5-1
5.1	Geographic Scope and Timeframe of the Cumulative Effects Analysis	5-1
5.2	Projects Contributing to Potential Cumulative Impacts	5-2
5.3	Cumulative Impact Analysis	5-2
5.3.1	Aesthetics and Visual Resources.....	5-5
5.3.2	Agricultural Resources	5-5
5.3.3	Air Quality.....	5-6
5.3.4	Biological Resources.....	5-8
5.3.5	Cultural Resources.....	5-9

5.3.6	Geology and Soils	5-10
5.3.7	Greenhouse Gas Emissions	5-10
5.3.8	Hazards/Hazardous Materials	5-11
5.3.9	Hydrology and Water Quality	5-12
5.3.10	Land Use Planning	5-12
5.3.11	Noise and Vibration	5-13
5.3.12	Transportation	5-13
5.3.13	Tribal Cultural Resources.....	5-14
5.3.14	Utilities/Service Systems.....	5-14
6	Effects Found Not Significant.....	6-1
6.1	Agriculture and Forestry Resources.....	6-1
6.1.1	Forestry Resources	6-1
6.2	Energy.....	6-1
6.2.1	Energy Types and Sources.....	6-1
6.2.2	Imperial County Energy Consumption	6-2
6.2.3	Proposed Project Energy and Fuel Consumption.....	6-3
6.2.4	Compliance with State or Local Plans for Renewable Energy or Energy Efficiency	6-4
6.3	Mineral Resources	6-4
6.4	Population and Housing	6-5
6.5	Public Services.....	6-5
6.6	Recreation	6-6
6.7	Utilities and Service Systems.....	6-6
6.8	Wildfire.....	6-7
7	Alternatives.....	7-1
7.1	Introduction.....	7-1
7.2	Criteria for Alternatives Analysis	7-1
7.3	Alternatives Considered but Rejected	7-2
7.3.1	Alternative Site	7-2
7.3.2	Original Site Plan Submittal	7-2
7.3.3	Original Access Route for Heavy Construction Equipment.....	7-2
7.4	Alternative 1: No Project/No Development Alternative	7-3
7.4.1	Environmental Impact of Alternative 1: No Project/No Development Alternative	7-3
7.5	Alternative 2: Reduced Project Site	7-7
7.5.1	Environmental Impact of Alternative 2: Reduced Project Site	7-7
7.6	Environmentally Superior Alternative	7-10
8	References	8-1
9	EIR Preparers and Persons and Organizations Contacted	9-1
9.1	EIR Preparers.....	9-1
9.2	Persons and Organizations Contacted	9-1



Tables

Table ES-1. Summary of Project Impacts and Proposed Mitigation Measures.....	ES-3
Table ES-2. Comparison of Alternative Impacts to Proposed Project.....	ES-31
Table 2-1. Solar Energy Facility Site Assessor Parcel Numbers, Acreages, and Zoning	2-1
Table 3.2-1. Consistency with Applicable General Plan Conservation and Open Space Policies	3.2-2
Table 3.3-1. Imperial County Change in Agricultural Land Use Summary (2016 to 2018)	3.3-3
Table 3.3-2. Project Consistency with Applicable General Plan Agricultural Policies	3.3-6
Table 3.4-1. Criteria Air Pollutants – Summary of Common Sources and Effects	3.4-2
Table 3.4-2. Attainment Status of Criteria Pollutants in the Imperial County Portion of the Salton Sea Air Basin.....	3.4-3
Table 3.4-3. Summary of Local Ambient Air Quality Data	3.4-4
Table 3.4-4. Ambient Air Quality Standards.....	3.4-6
Table 3.4-5. Project Consistency with Applicable Plan Policies	3.4-10
Table 3.4-6. Imperial County Air Pollution Control District Significance Thresholds – Pounds per Day	3.4-12
Table 3.4-7. Project Construction-Generated Emissions – Unmitigated	3.4-15
Table 3.4-8. Project Construction-Generated Emissions – Mitigated	3.4-15
Table 3.4-9. Project Operational Emissions.....	3.4-16
Table 3.4-10. Proposed Project Displaced Criteria Pollutant Emissions (Tons).....	3.4-17
Table 3.5-1. Vegetation Communities or Land Cover Types within the BSA	3.5-2
Table 3.5-2. Aquatic Resources and Associated Vegetation on the Project Site	3.5-21
Table 3.5-3. Project Consistency with General Plan Goals and Policies	3.5-33
Table 3.6-1. Previously Recorded Cultural Resources Within 1-Mile of the Project Area	3.6-5
Table 3.6-2. Updated and Newly Recorded Resources within the Project Area	3.6-6=7
Table 3.6-3. Project Consistency with Applicable General Plan Goals and Objectives	3.6-14
Table 3.7-1. Faults with a Risk Contribution of Greater than One Percent	3.7-5
Table 3.7-2. Project Consistency with Applicable General Plan Policies	3.7-11
Table 3.8-1. California Greenhouse Gas Emissions Inventory 2000 to 2018.....	3.8-3
Table 3.8-2. Project Construction-Related Greenhouse Gas Emissions.....	3.8-11
Table 3.8-3. Project Operation-Related Greenhouse Gas Emissions	3.8-12
Table 3.8-4. Proposed Project Displaced GHG Emissions (Metric Tons)	3.8-13
Table 3.10-1. Beneficial Uses of Receiving Waters.....	3.10-5
Table 3.10-2. Project Consistency with Applicable General Plan Policies	3.10-7
Table 3.10-3. Source Control Best Management Practices.....	3.10-12
Table 3.11-1. Project Consistency with Applicable General Plan Policies	3.11-5
Table 3.12-1. Existing (Baseline) Noise Measurements.....	3.12-4
Table 3.12-2. Human Reaction and Damage to Buildings for Continuous or Frequent Intermittent Vibration Levels.....	3.12-7
Table 3.12-3. Representative Vibration Source Levels for Construction Equipment.....	3.12-7
Table 3.12-4. Land Use Compatibility for Community Noise Environments.....	3.12-9
Table 3.12-5. Project Consistency with Applicable General Plan Noise Policies	3.12-11
Table 3.12-6. Imperial County Exterior Noise Standards	3.12-13
Table 3.12-7. Construction Average Noise Levels (dBA) at the Nearest Receptor.....	3.12-15
Table 3.12-8. Modeled Operational Noise Levels at Nearest Sensitive Receptor.....	3.12-17
Table 3.12-9. Project Construction Vibration Levels at 100 Feet	3.12-18

Table 3.13-1. HCM Level of Service Thresholds for Intersections	3.13-5
Table 3.13-2. Caltrans Freeway Segment Level of Service Definitions	3.13-5
Table 3.13-3. Construction Phase Trip Generation	3.13-6
Table 3.14-1. Project Consistency with Applicable General Plan Goals and Objectives	3.14-4
Table 5-1. Projects Considered in the Cumulative Impact Analysis	5-3
Table 6-1. Electricity Consumption in Imperial County 2015–2019	6-2
Table 6-2. Natural Gas Consumption in Imperial County 2015–2019	6-2
Table 6-3. Automotive Fuel Consumption in Imperial County 2016–2020	6-2
Table 6-4. Proposed Project Energy and Fuel Consumption	6-3
Table 7-1. Comparison of Alternative Impacts to Proposed Project.....	7-11



Figures

Figure 2-1. Regional Location.....	2-2
Figure 2-2. Project Site	2-3
Figure 2-3. Site Plan	2-5
Figure 2-4. Construction Worker Access	2-11
Figure 2-5. Bridge Crossing – Pedestrian Access Only.....	2-12
Figure 2-6. Proposed Heavy Construction Equipment Access.....	2-13
Figure 2-7. Proposed Bridge Crossings over All-American Canal.....	2-15
Figure 3.5 1. Vegetation Communities and Land Cover Types in the BSA (Sheet 1 of 9).....	3.5-3
Figure 3.5 2. Vegetation Communities and Land Cover Types in the BSA (Sheet 2 of 9).....	3.5-4
Figure 3.5 3. Vegetation Communities and Land Cover Types in the BSA (Sheet 3 of 9).....	3.5-5
Figure 3.5 4. Vegetation Communities and Land Cover Types in the BSA (Sheet 4 of 9).....	3.5-6
Figure 3.5 5. Vegetation Communities and Land Cover Types in the BSA (Sheet 5 of 9).....	3.5-7
Figure 3.5 6. Vegetation Communities and Land Cover Types in the BSA (Sheet 6 of 9).....	3.5-8
Figure 3.5 7. Vegetation Communities and Land Cover Types in the BSA (Sheet 7 of 9).....	3.5-9
Figure 3.5 8. Vegetation Communities and Land Cover Types in the BSA (Sheet 8 of 9).....	3.5-10
Figure 3.5 9. Vegetation Communities and Land Cover Types in the BSA (Sheet 9 of 9).....	3.5-11
Figure 3.5 10. Special-Status Species Observed On Site (Sheet 1 of 2).....	3.5-15
Figure 3.5 11. Special-Status Species Observed On Site (Sheet 2 of 2).....	3.5-16
Figure 3.5 12. Potential Jurisdictional Waters (Sheet 1 of 6).....	3.5-23
Figure 3.5 13. Potential Jurisdictional Waters (Sheet 2 of 6).....	3.5-24
Figure 3.5 14. Potential Jurisdictional Waters (Sheet 3 of 6).....	3.5-25
Figure 3.5 15. Potential Jurisdictional Waters (Sheet 4 of 6).....	3.5-26
Figure 3.5 16. Potential Jurisdictional Waters (Sheet 5 of 6).....	3.5-27
Figure 3.5 17. Potential Jurisdictional Waters (Sheet 6 of 6).....	3.5-28
Figure 3.7-1. Soils Mapped on the Project Site	3.7-3
Figure 3.7-2. Regional Fault Map	3.7-7
Figure 3.11-1. General Plan Land Use Designations	3.11-2
Figure 3.11-2. Zoning Designations.....	3.11-3
Figure 3.12-1. Common Noise Levels	3.12-2
Figure 3.12-2. Noise Measurement Locations.....	3.12-5
Figure 3.13-1. Proposed Heavy Construction Equipment Access.....	3.13-11
Figure 3.13-2. Proposed Bridge Crossings over All-American Canal.....	3.13-13
Figure 5-1. Cumulative Projects.....	5-4

This page is intentionally blank.



Appendices

Appendix A	Initial Study and Notice of Preparation and Comment Letters
Appendix B	Visual Impact Assessment Letter Report
Appendix C	Air Quality and Greenhouse Gas Assessment
Appendix D	Biological Resources Technical Report (BRTR)
Appendix E	Aquatic Resources Delineation Report
Appendix F	Cultural Resources Inventory
Appendix G	Preliminary Geological and Geotechnical Hazard Evaluation Report
Appendix H	Phase I Environmental Site Assessment
Appendix I	Drainage Plan
Appendix J	Noise Impact Assessment
Appendix K	Traffic Impact Study
Appendix L	Water Supply Assessment
Appendix M	Energy Impact Assessment

This page is intentionally blank.

Executive Summary

This Environmental Impact Report (EIR) has been prepared in compliance with the California Environmental Quality Act (CEQA) Public Resources Code [PRC] Section 21000 et seq., the CEQA Guidelines (Section 15000 et seq.) as promulgated by the California Resources Agency and the Governor's Office of Planning and Research (OPR). The purpose of this environmental document is to assess the potential environmental effects associated with the VEGA SES 4 Solar Energy Project and to propose mitigation measures, where required, to reduce significant impacts.

Project Overview

The VEGA SES 4 Solar Energy Project is located on approximately 450 acres of privately-owned land in the southernmost portion of Imperial County, California. The project site is between the U.S./Mexico international border and the All-American Canal, on the California side. The project site is proposed on two parcels (Assessor Parcel Numbers 059-300-015 and 059-300-017) that are contiguous with each other.

The proposed project consists of three primary components: 1) solar energy generation equipment and associated facilities including a substation and access roads (herein referred to as "solar energy facility"); 2) battery energy storage system (BESS); and 3) gen-tie line that would connect the proposed on-site substation to the point of interconnection at the existing Imperial Irrigation District's (IID) 92-kV "P" line.

The proposed project involves the construction of a 100-megawatt (MW) alternating current (AC) photovoltaic (PV) solar energy facility with an integrated 100 MW BESS (not to exceed 200 MW) on approximately 450 acres of land. The project proposes to utilize either thin film or crystalline solar PV technology modules mounted either on fixed frames or horizontal single-axis tracker systems. The project would include electronic/electrical equipment, an on-site substation, access road(s) and fencing. The electrical energy produced by the project would be conducted through the project's interconnection facilities to the proposed 92 kV generator intertie (gen-tie) line and delivered to the existing IID approved point of interconnection on the 92-kV "P" Line located immediately north of the project site and the All-American Canal.

Purpose of an EIR

The purpose of an EIR is to analyze the potential environmental impacts associated with a project. CEQA (Section 15002) states that the purpose of CEQA is to: (1) inform the public and governmental decision makers of the potential significant environmental impacts of a project; (2) identify the ways that environmental damage can be avoided or significantly reduced; (3) prevent significant avoidable damage to the environment by requiring changes in projects through the use of alternatives or mitigation measures when the governmental agency finds the changes to be feasible; and (4) disclose to the public the reasons why a governmental agency approved the project in the manner the agency chose if significant environmental effects are involved.

Eliminated from Further Review in Notice of Preparation

Based on the Initial Study and Notice of Preparation (IS/NOP) prepared for the proposed project (Appendix A of this EIR), Imperial County (County) determined that environmental effects to Forestry

Resources, Energy, Mineral Resources, Population/Housing, Public Services, Recreation, Utilities (Wastewater, Stormwater, and Solid Waste), and Wildfire would not be potentially significant. Therefore, these impacts are not addressed in this EIR; however, the rationale for eliminating these issues is discussed in Chapter 6.0, Effects Found Not Significant.

Summary of Significant Impacts and Mitigation Measures that Reduce or Avoid the Significant Impacts

Based on the analysis presented in the IS/NOP and the information provided in the comments to the IS/NOP, the following environmental topics are analyzed in this EIR:

- Aesthetics
- Agricultural Resources
- Air Quality
- Biological Resources
- Cultural Resources
- Geology and Soils
- Greenhouse Gas Emissions
- Hazards and Hazardous Materials
- Hydrology/Water Quality
- Land Use Planning
- Noise and Vibration
- Transportation
- Tribal Cultural Resources
- Utilities/Service Systems (Water Supply)

Table ES-1 summarizes existing environmental impacts that were determined to be potentially significant, mitigation measures, and level of significance after mitigation associated with the project.

Areas of Controversy and Issues to be Resolved

Areas of Concern

Section 15123(b)(2) of the CEQA Guidelines requires that an EIR identify areas of controversy as well as issues to be resolved known to the Lead Agency, including issues raised by other agencies and the public. A primary issue associated with this solar farm project, and other solar facility projects that are proposed in the County, is the corresponding land use compatibility and fiscal/economic impacts to the County. Through the environmental review process for this project, other areas of concern and issues to be resolved include impacts on IID drains, project site access for construction workers, construction vehicles and equipment, and operational requirements (e.g., periodic maintenance and emergency response access), and U.S./Mexico border patrol operations.

Detailed analyses of these topics are included within each corresponding section contained within this document.



Table ES-1. Summary of Project Impacts and Proposed Mitigation Measures

Environmental Impact	Significance Before Mitigation	Proposed Mitigation Measures	Significance After Mitigation
Agricultural Resources			
<p>Impact 3.3-3: Involve other changes in the existing environment which, due to their location or nature, could result in conversion of Farmland, to non-agricultural use.</p>	<p>Significant</p>	<p>AG-1 Pest Management Plan. Prior to the issuance of a grading permit or building permit (whichever occurs first), a Pest Management Plan shall be developed by the project applicant and approved by the County of Imperial Agricultural Commissioner. The project applicant shall maintain a Pest Management Plan until reclamation is complete. The plan shall provide the following:</p> <ol style="list-style-type: none"> 1. Monitoring, preventative, and management strategies for weed and pest control during construction activities at any portion of the project (e.g., transmission line); 2. Control and management of weeds and pests in areas temporarily disturbed during construction where native seed will aid in site revegetation as follows: <ul style="list-style-type: none"> • Monitor for all pests including insects, vertebrates, weeds, and pathogens. Promptly control or eradicate pests when found, or when notified by the Agricultural Commissioner’s office that a pest problem is present on the project site. The assistance of a licensed pest control advisor is recommended. All treatments must be performed by a qualified applicator or a licensed pest control business; • All treatments must be performed by a qualified applicator or a licensed pest control operator; • “Control” means to reduce the population of common pests below economically damaging levels, and includes attempts to exclude pests before infestation, and effective control methods after infestation. Effective control methods may include physical/mechanical removal, bio control, cultural control, or chemical treatments; 	<p>Less than Significant</p>

Table ES-1. Summary of Project Impacts and Proposed Mitigation Measures

Environmental Impact	Significance Before Mitigation	Proposed Mitigation Measures	Significance After Mitigation
		<ul style="list-style-type: none"> • Use of “permanent” soil sterilants to control weeds or other pests is prohibited because this would interfere with reclamation; • Notify the Agricultural Commissioner’s office immediately regarding any suspected exotic/invasive pest species as defined by the California Department of Food Agriculture and the U.S. Department of Agriculture. Request a sample be taken by the Agricultural Commissioner’s Office of a suspected invasive species. Eradication of exotic pests shall be done under the direction of the Agricultural Commissioner’s Office and/or California Department of Food and Agriculture; • Obey all pesticide use laws, regulations, and permit conditions; • Allow access by Agricultural Commissioner staff for routine visual and trap pest surveys, compliance inspections, eradication of exotic pests, and other official duties; • Ensure all project employees that handle pest control issues are appropriately trained and certified, all required records are maintained and made available for inspection, and all required permits and other required legal documents are current; • Maintain records of pests found and treatments or pest management methods used. Records should include the date, location/block, project name (current and previous if changed), and methods used. For pesticides include the chemical(s) used, EPA Registration numbers, application rates, etc. A pesticide use report may be used for this; • Submit a report of monitoring, pest finds, and treatments, or other pest management methods to the Agricultural Commissioner quarterly within 15 days after the end of the previous quarter, and upon request. The report is required even if no pests were found or treatment occurred. It may consist of 	



Table ES-1. Summary of Project Impacts and Proposed Mitigation Measures

Environmental Impact	Significance Before Mitigation	Proposed Mitigation Measures	Significance After Mitigation
		<p>a copy of all records for the previous quarter or may be a summary letter/report as long as the original detailed records are available upon request.</p> <ol style="list-style-type: none"> 3. A long-term strategy for weed and pest control and management during the operation of the proposed project. Such strategies may include, but are not limited to: <ul style="list-style-type: none"> • Use of specific types of herbicides and pesticides on a scheduled basis. 4. Maintenance and management of project site conditions to reduce the potential for a significant increase in pest-related nuisance conditions on surrounding agricultural lands. 5. The project shall reimburse the Agricultural Commissioner's office for the actual cost of investigations, inspections, or other required non-routine responses to the site that are not funded by other sources. 	
Air Quality			
<p>Impact 3.4-1: Conflict with or obstruct implementation of the applicable air quality plan.</p>	<p>Less than Significant</p>	<p>AQ-1 Fugitive Dust Control. During construction activities, the constructor contractor shall employ the following PM₁₀ reducing measures:</p> <ol style="list-style-type: none"> 1. All unpaved roads associated with construction shall be effectively stabilized of dust emissions using Imperial County Air Pollution Control District-approved chemical stabilizers/suppressant before the commencement of construction, and every 30 days thereafter until the end of all construction activities. Unpaved roads associated with construction include: <ul style="list-style-type: none"> • The driveway entrance off State Route 98; • The project designated 3.5-acre staging/parking area north of the All-American Canal; • The 1.0 mile of dirt road south of the All-American Canal; and 	<p>Less than Significant</p>

Table ES-1. Summary of Project Impacts and Proposed Mitigation Measures

Environmental Impact	Significance Before Mitigation	Proposed Mitigation Measures	Significance After Mitigation
		<ul style="list-style-type: none"> • The 20 miles of existing dirt road paralleling the U.S./Mexico Border from Gordon Wells Road to the project site. <p>Monthly application of Imperial County Air Pollution Control District-approved chemical stabilizers/suppressant shall be applied at a rate of 0.1 gallon/square yard of chemical dust suppressant.</p> <ol style="list-style-type: none"> 2. Prior to any earthmoving activity, the applicant shall submit a construction dust control plan and obtain Imperial County Air Pollution Control District and Imperial County Planning and Development Services Department (ICPDS) approval. 3. Pursuant to ICAPCD, all construction sites, regardless of size, must comply with the requirements contained within Regulation VIII – Fugitive Dust Control Measures. Whereas these Regulation VIII measures are mandatory and are not considered project environmental mitigation measures, the ICAPCD CEQA Handbook’s required additional standard and enhanced mitigation measures listed below shall be implemented prior to and during construction. ICAPCD will verify implementation and compliance with these measures as part of the grading permit review/approval process. <p>ICAPCD Standard Measures for Fugitive Dust (PM₁₀) Control</p> <ul style="list-style-type: none"> • All disturbed areas, including bulk material storage, which is not being actively utilized, shall be effectively stabilized and visible emissions shall be limited to no greater than 20 percent opacity for dust emissions by using water, chemical stabilizers, dust suppressants, tarps, or other suitable material, such as vegetative groundcover. • All on-site and off-site unpaved roads will be effectively stabilized, and visible emissions shall be limited to no greater than 20 percent opacity for dust emissions by paving, chemical stabilizers, dust suppressants, and/or watering. 	



Table ES-1. Summary of Project Impacts and Proposed Mitigation Measures

Environmental Impact	Significance Before Mitigation	Proposed Mitigation Measures	Significance After Mitigation
		<ul style="list-style-type: none"> • All unpaved traffic areas 1 acre or more with 75 or more average vehicle trips per day will be effectively stabilized and visible emissions shall be limited to no greater than 20 percent opacity for dust emissions by paving, chemical stabilizers, dust suppressants, and/or watering. • The transport of bulk materials shall be completely covered unless 6 inches of freeboard space from the top of the container is maintained with no spillage and loss of bulk material. In addition, the cargo compartment of all haul trucks is to be cleaned and/or washed at delivery site after removal of bulk material. • All track-out or carry-out will be cleaned at the end of each workday or immediately when mud or dirt extends a cumulative distance of 50 linear feet or more onto a paved road within an urban area. • Movement of bulk material handling or transfer shall be stabilized prior to handling or at points of transfer with application of sufficient water, chemical stabilizers, or by sheltering or enclosing the operation and transfer line. • The construction of any new unpaved road is prohibited within any area with a population of 500 or more unless the road meets the definition of a temporary unpaved road. Any temporary unpaved road shall be effectively stabilized, and visible emissions shall be limited to no greater than 20 percent opacity for dust emission by paving, chemical stabilizers, dust suppressants, and/or watering. <p>ICAPCD “Discretionary” Measures for Fugitive Dust (PM₁₀) Control</p>	

Table ES-1. Summary of Project Impacts and Proposed Mitigation Measures

Environmental Impact	Significance Before Mitigation	Proposed Mitigation Measures	Significance After Mitigation
		<ul style="list-style-type: none"> • Water exposed soil only in those areas where active grading and vehicle movement occurs with adequate frequency to control dust. • Replace ground cover in disturbed areas as quickly as possible. • Automatic sprinkler system installed on all soil piles. • Vehicle speed for all construction vehicles shall not exceed 15 miles per hour on any unpaved surface at the construction site. • Develop a trip reduction plan to achieve a 1.5 average vehicle ridership for construction employees. • Implement a shuttle service to and from retail services and food establishments during lunch hours. <p style="text-align: center;">Standard Mitigation Measures for Construction Combustion Equipment</p> <ul style="list-style-type: none"> • Use of alternative fueled or catalyst equipped diesel construction equipment, including all off-road and portable diesel-powered equipment. • Minimize idling time either by shutting equipment off when not in use or reducing the time of idling to 5 minutes as a maximum. • Limit, to the extent feasible, the hours of operation of heavy-duty equipment and/or the amount of equipment in use. • Replace fossil fueled equipment with electrically driven equivalents (provided they are not run via a portable generator set). <p style="text-align: center;">Enhanced Mitigation Measures for Construction Equipment</p>	



Table ES-1. Summary of Project Impacts and Proposed Mitigation Measures

Environmental Impact	Significance Before Mitigation	Proposed Mitigation Measures	Significance After Mitigation
		<p>To help provide a greater degree of reduction of PM emissions from construction combustion equipment, ICAPCD recommends the following enhanced measures.</p> <ul style="list-style-type: none"> • Curtail construction during periods of high ambient pollutant concentrations; this may include ceasing of construction activity during the peak hour of vehicular traffic on adjacent roadways. • Implement activity management (e.g., rescheduling activities to reduce short-term impacts). <p>AQ-2 Construction Equipment. Construction equipment shall be equipped with an engine designation of EPA Tier 2 or better (Tier 2+). A list of the construction equipment, including all off-road equipment utilized at the project site by make, model, year, horsepower and expected/actual hours of use, and the associated EPA Tier shall be submitted to the County Planning and Development Services Department and ICAPCD prior to the issuance of a grading permit. The equipment list shall be submitted periodically to ICAPCD to perform a NO_x analysis. ICAPCD shall utilize this list to calculate air emissions to verify that equipment use does not exceed significance thresholds. The Planning and Development Services Department and ICAPCD shall verify implementation of this measure.</p> <p>AQ-3 Dust Suppression. The project applicant shall employ a method of dust suppression (such as water or chemical stabilization) approved by ICAPCD. The project applicant shall apply chemical stabilization as directed by the product manufacturer to control dust between the panels as approved by ICAPCD, and other non-used areas (exceptions will be the paved entrance and parking area, and Fire Department access/emergency entry/exit points as approved by Fire/Office of Emergency Services [OES] Department).</p> <p>AQ-4 Operational Dust Control Plan. Prior to issuance of a Certificate of Occupancy, the applicant shall submit an operations dust control plan and obtain ICAPCD and ICPDS approval.</p>	

Table ES-1. Summary of Project Impacts and Proposed Mitigation Measures

Environmental Impact	Significance Before Mitigation	Proposed Mitigation Measures	Significance After Mitigation
		ICAPCD Rule 301 Operational Fees apply to any project applying for a building permit. At the time that building permits are submitted for the proposed project, ICAPCD shall review the project to determine if Rule 310 fees are applicable to the project.	
Biological Resources			
Impact 3.5-1: Impact on special-status species	Significant	<p>BIO-1 Rare Plant Surveys. Prior to initiating ground disturbance, rare plant surveys shall be conducted within suitable habitat on the project site during the appropriate blooming period for the Abrams’ spurge (approximately September through November), Wiggins’ croton (approximately March through May), and sand food (approximately April through June). The surveys shall be conducted by a botanist or qualified biologist in accordance with the USFWS Guidelines for Conducting and Reporting Botanical Inventories for Federally Listed, Proposed, and Candidate Plants (USFWS 1996); the CDFW Protocols for Surveying and Evaluating Impacts to Special Status Native Plant Populations and Sensitive Natural Communities (CDFW 2018); and the CNPS Botanical Survey Guidelines (CNPS 2001). If any special-status species are observed during the rare plant surveys, the location of the individual plant or population will be recorded with a submeter GPS device for mapping purposes. If project-related impacts to rare plants on the project site are unavoidable, then consultation with CDFW may be required to develop a mitigation plan or additional avoidance and minimization measures. Mitigation measures that may be implemented if the species is observed include establishing a no-disturbance buffer around locations of individuals or a population, salvage or seed collection, and additional monitoring requirements.</p> <p>BIO-2 General Impact Avoidance and Minimization Measures. The following measures will be applicable throughout the life of the project:</p> <ul style="list-style-type: none"> To reduce the potential indirect impact on migratory birds, bats and raptors, the project will comply with the APLIC 2012 Guidelines for 	Less than Significant



Table ES-1. Summary of Project Impacts and Proposed Mitigation Measures

Environmental Impact	Significance Before Mitigation	Proposed Mitigation Measures	Significance After Mitigation
		<p>overhead utilities, as appropriate, to minimize avian collisions with transmission facilities (APLIC 2012).</p> <ul style="list-style-type: none"> • All electrical components on the project site shall be either undergrounded or protected so that there will be no exposure to wildlife and therefore no potential for electrocution. • The project proponent shall designate a Project Biologist who shall be responsible for overseeing compliance with protective measures for the biological resources during vegetation clearing and work activities within and adjacent to areas of native habitat. The Project Biologist will be familiar with the local habitats, plants, and wildlife. The Project Biologist will also maintain communications with the Contractor to ensure that issues relating to biological resources are appropriately and lawfully managed and monitor construction. The Project Biologist will monitor activities within construction areas during critical times, such as vegetation removal, the implementation of Best Management Practices (BMP), and installation of security fencing to protect native species. The Project Biologist will ensure that all wildlife and regulatory agency permit requirements, conservation measures, and general avoidance and minimization measures are properly implemented and followed. • The boundaries of all areas to be newly disturbed (including solar facility areas, staging areas, access roads, and sites for temporary placement of construction materials and spoils) will be delineated with stakes and flagging prior to disturbance. All disturbances, vehicles, and equipment will be confined to the flagged areas. • No potential wildlife entrapments (e.g., trenches, bores) will be left uncovered overnight. Any uncovered pitfalls will be excavated to 3:1 slopes at the ends to provide wildlife escape ramps. Alternatively, man-made ramps may be installed. Covered pitfalls will be covered completely to prevent access by small mammals or reptiles. 	

Table ES-1. Summary of Project Impacts and Proposed Mitigation Measures

Environmental Impact	Significance Before Mitigation	Proposed Mitigation Measures	Significance After Mitigation
		<ul style="list-style-type: none"> • To avoid wildlife entrapment (including birds), all pipes or other construction materials or supplies will be covered or capped in storage or laydown area, and at the end of each workday in construction, quarrying and processing/handling areas. No pipes or tubing of sizes or inside diameters ranging from 1 to 10 inches will be left open either temporarily or permanently. • No anticoagulant rodenticides, such as Warfarin and related compounds (indandiones and hydroxycoumarins), may be used within the project site, on off-site project facilities and activities, or in support of any other project activities. • Avoid wildlife attractants. All trash and food-related waste shall be placed in self-closing containers and removed regularly from the site to prevent overflow. Workers shall not feed wildlife. Water applied to dirt roads and construction areas for dust abatement shall use the minimal amount needed to meet safety and air quality standards to prevent the formation of puddles, which could attract wildlife. Pooled rainwater or floodwater within retention basins will be removed to avoid attracting wildlife to the active work areas. • To minimize the likelihood for vehicle strikes on wildlife, speed limits will not exceed 15 miles per hour when driving on access roads. All vehicles required for O&M must remain on designated access/maintenance roads. • Avoid night-time construction lighting or if nighttime construction cannot be avoided use shielded directional lighting pointed downward and towards the interior of the project site, thereby avoiding illumination of adjacent natural areas and the night sky. • All construction equipment used for the Project will be equipped with properly operating and maintained mufflers. • Hazardous materials and equipment stored overnight, including small amounts of fuel to refuel hand-held equipment, will be stored 	



Table ES-1. Summary of Project Impacts and Proposed Mitigation Measures

Environmental Impact	Significance Before Mitigation	Proposed Mitigation Measures	Significance After Mitigation
		<p>within secondary containment when within 50 feet of open water to the fullest extent practicable. Secondary containment will consist of a ring of sandbags around each piece of stored equipment/structure. A plastic tarp/Visqueen lining with no seams shall be placed under the equipment and over the edges of the sandbags, or a plastic hazardous materials secondary containment unit shall be utilized by the Contractor.</p> <ul style="list-style-type: none"> • The Contractor will be required to conduct vehicle refueling in upland areas where fuel cannot enter waters of the U.S. and in areas that do not have potential to support federally threatened or endangered species. Any fuel containers, repair materials, including creosote-treated wood, and/or stockpiled material that is left on site overnight, will be secured in secondary containment within the work area and staging/assembly area and covered with plastic at the end of each workday. • In the event that no activity is to occur in the work area for the weekend and/or a period of time greater than 48 hours, the Contractor will ensure that all portable fuel containers are removed from the project site. • All equipment will be maintained in accordance with manufacturer's recommendations and requirements. • Equipment and containers will be inspected daily for leaks. Should a leak occur, contaminated soils and surfaces will be cleaned up and disposed of following the guidelines identified in the Stormwater Pollution Prevention Plan or equivalent, Materials Safety Data Sheets, and any specifications required by other permits issued for the project. • The Contractor will utilize off-site maintenance and repair shops as much as possible for maintenance and repair of equipment. 	

Table ES-1. Summary of Project Impacts and Proposed Mitigation Measures

Environmental Impact	Significance Before Mitigation	Proposed Mitigation Measures	Significance After Mitigation
		<ul style="list-style-type: none"> • If maintenance of equipment must occur onsite, fuel/oil pans, absorbent pads, or appropriate containment will be used to capture spills/leaks within all areas. Where feasible, maintenance of equipment will occur in upland areas where fuel cannot enter waters of the U.S. and in areas that do not have potential to support federally threatened or endangered species. • Appropriate BMPs will be used by the Contractor to control erosion and sedimentation and to capture debris and contaminants from bridge construction to prevent their deposition in waterways. No sediment or debris will be allowed to enter the creek or other drainages. All debris from construction of the bridge will be contained so that it does not fall into channel. Appropriate BMPs will be used by the Contractor during construction to limit the spread of resuspended sediment and to contain debris. • Erosion and sediment control devices used for the proposed project, including fiber rolls and bonded fiber matrix, will be made from biodegradable materials such as jute, with no plastic mesh, to avoid creating a wildlife entanglement hazard. • Firearms, open fires, and pets would be prohibited at all work locations and access roads. Smoking would be prohibited along the Project alignment. • Cross-country vehicle and equipment use outside of approved designated work areas and access roads shall be prohibited to prevent unnecessary ground and vegetation disturbance. • Any injured or dead wildlife encountered during project-related activities shall be reported to the project biologist, biological monitor, CDFW, or a CDFW-approved veterinary facility as soon as possible to report the observation and determine the best course of action. For special-status species, the Project Biologist shall notify the 	



Table ES-1. Summary of Project Impacts and Proposed Mitigation Measures

Environmental Impact	Significance Before Mitigation	Proposed Mitigation Measures	Significance After Mitigation
		<p>County, USFWS, and/or CDFW, as appropriate, within 24 hours of the discovery.</p> <ul style="list-style-type: none"> • Stockpiling of material will be allowed only within established work areas. • Actively manage the spread of noxious weeds. • The ground beneath all parked equipment and vehicles shall be inspected for wildlife before moving. <p>BIO-3 Worker Environmental Awareness Program. Prior to project construction, a Worker Environmental Awareness Program shall be developed and implemented by a qualified biologist and shall be available in both English and Spanish. Handouts summarizing potential impacts to special-status biological resources and the potential penalties for impacts to these resources shall be provided to all construction personnel. At a minimum, the education program shall include the following:</p> <ul style="list-style-type: none"> • The purpose for resource protection; • A description of special-status species including representative photographs and general ecology; • Occurrences of USACE, RWQCB, and CDFW regulated features in the Project study area; • Regulatory framework for biological resource protection and consequences if violated; • Sensitivity of the species to human activities; • Avoidance and minimization measures designed to reduce the impacts to special-status biological resources; • Environmentally responsible construction practices; • Reporting requirements; 	

Table ES-1. Summary of Project Impacts and Proposed Mitigation Measures

Environmental Impact	Significance Before Mitigation	Proposed Mitigation Measures	Significance After Mitigation
		<ul style="list-style-type: none"> • The protocol to resolve conflicts that may arise at any time during the construction process; and • Workers sign acknowledgement form indicating that the Environmental Awareness Training and Education Program that has been completed and would be kept on record. <p>BIO-4 Burrowing Owl Avoidance and Minimization. Take Avoidance (pre-construction) surveys for burrowing owl shall be completed prior to project construction. Surveys shall be conducted as detailed within Appendix D of the <i>Staff Report on Burrowing Owl Mitigation</i> (California Department of Fish and Game [CDFG] 2012). If burrowing owl is not detected, construction may proceed.</p> <ul style="list-style-type: none"> • If burrowing owl is identified during the non-breeding season (September 1 through January 31), then a 50-meter buffer will be established by the biological monitor. Construction within the buffer will be avoided until a qualified biologist determines that burrowing owl is no longer present or until a CDFW-approved exclusion plan has been implemented. The buffer distance may be reduced if noise attenuation buffers such as hay bales are placed between the occupied burrow and construction activities. • If burrowing owl is identified during the breeding season (February 1 through August 31), then an appropriate buffer will be established by the biological monitor in accordance with the <i>Staff Report on Burrowing Owl Mitigation</i> (CDFG 2012). Construction within the buffer will be avoided until a qualified biologist determines that burrowing owl is no longer present or until young have fledged. The buffer distance may be reduced in consultation with CDFW if noise attenuation buffers such as hay bales are placed between the occupied burrow and construction activities. <p>BIO-5 Pre-Construction Nesting Bird Survey. If construction or other project activities are scheduled to occur during the bird breeding season (typically February 1 through August 31 for raptors and March 15 through</p>	



Table ES-1. Summary of Project Impacts and Proposed Mitigation Measures

Environmental Impact	Significance Before Mitigation	Proposed Mitigation Measures	Significance After Mitigation
		<p>August 31 for the majority of migratory bird species), a pre-construction nesting-bird survey shall be conducted by a qualified avian biologist to ensure that active bird nests, including those for the northern harrier, yellow warbler, burrowing owl, and loggerhead strike, will not be disturbed or destroyed. The survey shall be completed no more than three days prior to initial ground disturbance. The nesting-bird survey shall include the project site and adjacent areas where project activities have the potential to affect active nests, either directly or indirectly due to construction activity or noise. If an active nest is identified, the biologist shall establish an appropriately sized disturbance-limit buffer around the nest using flagging or staking. Construction activities shall not occur within any disturbance-limit buffer zones until the nest is deemed inactive by the qualified biologist. If construction activities cease for a period of greater than three days during the bird breeding season, a pre-construction nesting bird survey shall be conducted prior to the commencement of activities. Final construction buffers or setback distances shall be determined by the qualified biologist in coordination with USFWS and CDFW on a case-by-case basis, depending on the species, season in which disturbance shall occur, the type of disturbance, and other factors that could influence susceptibility to disturbance (topography, vegetation, existing disturbance levels, etc.).</p> <p>BIO-6 Pre-Construction Survey for Special-Status Species. A pre-construction survey shall be conducted for special-status wildlife species within all areas of potential permanent and temporary disturbance. The pre-construction survey shall take place no more than 14 days prior to the start of ground-disturbing activities. The pre-construction surveys should take place regardless of breeding season timing and shall focus on identifying the presence of special-status wildlife species present on the project site or that were identified as having a high potential to occur on the site. These species include, but are not limited to, flat-tailed horned lizard, burrowing owl, norther harrier, and yellow warbler. Should any special-status species be identified during the pre-construction survey, consultation to develop suitable avoidance and minimization</p>	

Table ES-1. Summary of Project Impacts and Proposed Mitigation Measures

Environmental Impact	Significance Before Mitigation	Proposed Mitigation Measures	Significance After Mitigation
		<p>measures with the appropriate agency (USFWS, CDFW) may need to be undertaken.</p> <p>BIO-7 Bat Acoustic Surveys and Monitoring. To avoid impacts to bat species, a qualified bat biologist shall conduct an appropriate combination of sampling, exit counts, and acoustic surveys to determine if bats are using the palm tree resources in the project area. If project-related impacts to bat species are unavoidable, additional measures may need to be implemented to reduce or eliminate impacts to bat species, including maternity roosts, such as tree removal occurring outside of bat breeding season (October through February) or two-step, two-day removal of palm trees under supervision of a qualified bat biologist.</p>	
Cultural Resources			
<p>Impact 3.6-1: Substantial adverse change in the significance of a historical resource.</p>	<p>Significant</p>	<p>CR-1 Environmentally Sensitive Area Fencing. Prior to issuance of grading permits and in coordination with a qualified archaeologist to be retained by the project applicant, the construction zone shall be narrowed or otherwise altered to avoid Sites 2020-142-001, 2020-142-002, 2020-142-004, 2020-142-005, and 2020-142-008. The area within 100 feet of Sites 2020-142-001, 2020-142-002, 2020-142-004, 2020-142-005, and 2020-142-008 shall be designated Environmentally Sensitive Area (ESA) and fenced or flagged with exclusion markers to ensure avoidance. Protective fencing shall not identify the protected area as a cultural resource area in order to discourage unauthorized disturbance or collection of artifacts. The ESA fencing or flags shall remain in place throughout project construction.</p> <p>CR-2 Evaluate Significance of Find (Unknown Cultural Resources). If subsurface deposits believed to be cultural in origin are discovered during construction, all work must halt within a 100-foot radius of the discovery. A qualified professional archaeologist who meets the Secretary of the Interior’s Standards for prehistoric and historic archaeology and is familiar with the resources of the region, shall be retained to evaluate the significance of the find, and shall have the</p>	<p>Less than Significant</p>



Table ES-1. Summary of Project Impacts and Proposed Mitigation Measures

Environmental Impact	Significance Before Mitigation	Proposed Mitigation Measures	Significance After Mitigation
		<p>authority to modify the no work radius as appropriate, using professional judgment. The following notifications shall apply, depending on the nature of the find:</p> <ul style="list-style-type: none"> • If the professional archaeologist determines that the find does not represent a cultural resource, work may resume immediately, and no agency notifications are required. • If the professional archaeologist determines that the find does represent a cultural resource from any time period or cultural affiliation, he or she shall immediately notify the Imperial County Planning and Development Services Department. The Imperial County Planning and Development Services Department shall consult with the professional archaeologist on a finding of eligibility and implement appropriate treatment measures if the find is determined to be an Historical Resource under CEQA, as defined in Section 15064.5(a) of the CEQA Guidelines, or an Historic Property, as defined in 36 CFR 60.4. Work may not resume within the no-work radius until the Imperial County Planning and Development Services Department, through consultation as appropriate, determine that the site either: 1) is not an Historical Resource under CEQA or an Historic Property under Section 106; or 2) that the treatment measures have been completed to their satisfaction. 	
<p>Impact 3.6-2: Substantial adverse change in the significance of an archaeological resource.</p>	<p>Significant</p>	<p>CR-3 Evaluate Significance of Find (Unknown Archaeological Resources). In the event of the discovery of previously unidentified archaeological materials, the contractor shall immediately cease all work activities within approximately 100 feet of the discovery. After cessation of excavation, the contractor shall immediately contact the Imperial County Department of Planning and Development Services Department. Except in the case of cultural items that fall within the scope of the Native American Grave Protection and Repatriation Act, the discovery of any cultural resource within the project area shall not be grounds for a “stop work” notice or otherwise interfere with the project’s continuation except as set forth in this paragraph.</p>	<p>Less than Significant</p>

Table ES-1. Summary of Project Impacts and Proposed Mitigation Measures

Environmental Impact	Significance Before Mitigation	Proposed Mitigation Measures	Significance After Mitigation
		<p>In the event of an unanticipated discovery of archaeological materials during construction, the applicant shall retain the services of a qualified professional archaeologist, meeting the Secretary of the Interior’s Standards for a Qualified Archaeologist, to evaluate the significance of the materials prior to resuming any construction-related activities in the vicinity of the find. If the qualified archaeologist determines that the discovery constitutes a significant resource under CEQA and it cannot be avoided, the applicant shall implement an archaeological data recovery program.</p>	
<p>Impact 3.6-3: Disturb human remains.</p>	<p>Significant</p>	<p>CR-4 Human Remains. If subsurface deposits believed to be human in origin are discovered during construction, all work must halt within a 100-foot radius of the discovery. A qualified professional archaeologist who meets the Secretary of the Interior’s Standards for prehistoric and historic archaeology and is familiar with the resources of the region, shall be retained to evaluate the significance of the find, and shall have the authority to modify the no work radius as appropriate, using professional judgment. The following notifications shall apply, depending on the nature of the find:</p> <ul style="list-style-type: none"> • If the find includes human remains, or remains that are potentially human, the professional archaeologist shall ensure reasonable protection measures are taken to protect the discovery from disturbance (AB 2641). The archaeologist shall notify the Imperial County Coroner (per § 7050.5 of the Health and Safety Code). The provisions of § 7050.5 of the California Health and Safety Code, § 5097.98 of the California PRC, and AB 2641 will be implemented. • If the Coroner determines the remains are Native American and not the result of a crime scene, the Coroner will notify the NAHC, which then will designate a Native American Most Likely Descendant (MLD) for the project (§ 5097.98 of the PRC). The designated MLD will have 48 hours from the time access to the property is granted to make recommendations concerning treatment of the remains. If the landowner does not agree with the recommendations of the MLD, 	<p>Less than Significant</p>



Table ES-1. Summary of Project Impacts and Proposed Mitigation Measures

Environmental Impact	Significance Before Mitigation	Proposed Mitigation Measures	Significance After Mitigation
		<p>the NAHC may mediate (§ 5097.94 of the PRC). If no agreement is reached, the landowner must rebury the remains where they will not be further disturbed (§ 5097.98 of the PRC). This will also include either recording the site with the NAHC or the appropriate Information Center; using an open space or conservation zoning designation or easement; or recording a reinternment document with the county in which the property is located (AB 2641). Work may not resume within the no-work radius until the Imperial County Planning and Development Services Department, through consultation as appropriate, determine that the treatment measures have been completed to their satisfaction.</p>	
Geology and Soils			
<p>Impact 3.7-2: Possible risks to people and structures caused by strong seismic ground shaking.</p>	<p>Significant</p>	<p>GEO-1 Prepare Geotechnical Report(s) as Part of Final Engineering for the Project and Implement Required Measures. Facility design for all project components shall comply with the site-specific design recommendations as provided by a licensed geotechnical or civil engineer to be retained by the project applicant. The final geotechnical and/or civil engineering report shall address and make recommendations on the following:</p> <ul style="list-style-type: none"> • Site preparation; • Soil bearing capacity; • Appropriate sources and types of fill; • Potential need for soil amendments; • Structural foundations; • Grading practices; • Soil corrosion of concrete and steel; • Erosion/winterization; • Seismic ground shaking; 	<p>Less than Significant</p>

Table ES-1. Summary of Project Impacts and Proposed Mitigation Measures

Environmental Impact	Significance Before Mitigation	Proposed Mitigation Measures	Significance After Mitigation
		<ul style="list-style-type: none"> • Liquefaction; and • Expansive/unstable soils. <p>In addition to the recommendations for the conditions listed above, the geotechnical investigation shall include subsurface testing of soil and groundwater conditions and shall determine appropriate foundation designs that are consistent with the version of the CBC that is applicable at the time building and grading permits are applied for. All recommendations contained in the final geotechnical engineering report shall be implemented by the project applicant. The final geotechnical and/or civil engineering report shall be submitted to Imperial County Public Works Department, Engineering Division for review and approval prior to issuance of building permits.</p>	
Impact 3.7-3: Possible risks to people and structures caused by seismic related ground failure, including liquefaction.	Significant	Implement Mitigation Measure GEO-1.	Less than Significant
Impact 3.7-5: Substantial soil erosion or the loss of topsoil.	Significant	Implement Mitigation Measures GEO-1 and HYD-1.	Less than Significant
Impact 3.7-6: Located on a geologic unit or soil that is unstable or that would become unstable as a result of the project, and potentially result in on- or off-site landslide, lateral spreading, subsidence, liquefaction, or collapse.	Significant	Implement Mitigation Measure GEO-1.	Less than Significant
Impact 3.7-7: Expansive soils.	Significant	Implement Mitigation Measure GEO-1.	Less than Significant
Impact 3.7-9: Directly or indirectly destroy paleontological resources.	Significant	GEO-2 Paleontological Resources. In the event that unanticipated paleontological resources or unique geologic resources are encountered during ground-disturbing activities, work must cease within 50 feet of the	Less than Significant



Table ES-1. Summary of Project Impacts and Proposed Mitigation Measures

Environmental Impact	Significance Before Mitigation	Proposed Mitigation Measures	Significance After Mitigation
		discovery and a paleontologist shall be hired to assess the scientific significance of the find. The consulting paleontologist shall have knowledge of local paleontology and the minimum levels of experience and expertise as defined by the <i>Society of Vertebrate Paleontology's Standard Procedures (2010) for the Assessment and Mitigation of Adverse Impacts to Paleontological Resources</i> . If any paleontological resources or unique geologic features are found within the project site, the consulting paleontologist shall prepare a paleontological Treatment and Monitoring Plan to include the methods that will be used to protect paleontological resources that may exist within the project site, as well as procedures for monitoring, fossil preparation and identification, curation of specimens into an accredited repository, and preparation of a report at the conclusion of the monitoring program.	
Hydrology/Water Quality			
Impact 3.10-1: Violation of water quality standards.	Significant	HYD-1 Prepare SWPPP and Implement BMPs Prior to Construction and Site Restoration. The project applicant or its contractor shall prepare an SWPPP specific to the project and be responsible for securing coverage under SWRCB's NPDES stormwater permit for general construction activity (Order 2009-0009-DWQ). The SWPPP shall identify specific actions and BMPs relating to the prevention of stormwater pollution from project-related construction sources by identifying a practical sequence for site restoration, BMP implementation, contingency measures, responsible parties, and agency contacts. The SWPPP shall reflect localized surface hydrological conditions and shall be reviewed and approved by the appropriate agency prior to commencement of work and shall be made conditions of the contract with the contractor selected to build and decommission the project. The SWPPP shall incorporate control measures in the following categories: <ul style="list-style-type: none"> • Soil stabilization and erosion control practices (e.g., hydroseeding, erosion control blankets, mulching) • Sediment control practices (e.g., temporary sediment basins, fiber rolls) 	Less than Significant

Table ES-1. Summary of Project Impacts and Proposed Mitigation Measures

Environmental Impact	Significance Before Mitigation	Proposed Mitigation Measures	Significance After Mitigation
		<ul style="list-style-type: none"> • Temporary and post-construction on- and off-site runoff controls • Special considerations and BMPs for water crossings and drainages • Monitoring protocols for discharge(s) and receiving waters, with emphasis place on the following water quality objectives: dissolved oxygen, floating material, oil and grease, potential of hydrogen (pH), and turbidity • Waste management, handling, and disposal control practices • Corrective action and spill contingency measures • Agency and responsible party contact information • Training procedures that shall be used to ensure that workers are aware of permit requirements and proper installation methods for BMPs specified in the SWPPP <p>The SWPPP shall be prepared by a Qualified SWPPP Practitioner and/or Qualified SWPPP Developer with BMPs selected to achieve maximum pollutant removal and that represent the best available technology that is economically achievable. Emphasis for BMPs shall be placed on controlling discharges of oxygen-depleting substances, floating material, oil and grease, acidic or caustic substances or compounds, and turbidity. BMPs for soil stabilization and erosion control practices and sediment control practices will also be required. Performance and effectiveness of these BMPs shall be determined either by visual means where applicable (i.e., observation of above-normal sediment release), or by actual water sampling in cases where verification of contaminant reduction or elimination, (inadvertent petroleum release) is required to determine adequacy of the measure.</p> <p>HYD-2 Incorporate Post-Construction Runoff, Source Control, and Treatment Control BMPs into Final Project Drainage Plan. The project's Final Drainage Plan shall adhere to the County's Engineering Guidelines Manual, IID "Draft" Hydrology Manual, or other recognized</p>	



Table ES-1. Summary of Project Impacts and Proposed Mitigation Measures

Environmental Impact	Significance Before Mitigation	Proposed Mitigation Measures	Significance After Mitigation
		source with approval by the County Engineer to control and manage the on- and off-site discharge of stormwater to existing drainage systems. The Final Drainage Plan shall provide both short- and long-term drainage solutions to ensure the proper sequencing of drainage facilities and shall include source control and treatment BMPs to adequately treat collected runoff prior to discharge, as necessary.	
Impact 3.10-3: Result in substantial erosion or siltation on or off site.	Significant	Implement Mitigation Measure HYD-1.	Less than Significant
Impact 3.10-4: Substantially increase the rate or amount of surface runoff in a manner which would result in flooding on or off site.	Significant	Implement Mitigation Measure HYD-1.	Less than Significant
Impact 3.10-5: Create or contribute runoff water which would exceed the capacity of existing or planned stormwater drainage systems or provide substantial additional sources of polluted runoff.	Significant	Implement Mitigation Measures HYD-1 and HYD-2.	Less than Significant
Impact 3.10-8: Conflict with or obstruct implementation of a water quality control plan or sustainable groundwater management plan.	Significant	Implement Mitigation Measures HYD-1 and HYD-2.	Less than Significant

This page is intentionally blank.

Statement of Overriding Considerations

CEQA Guidelines Section 15093 requires the Lead Agency to balance, as applicable, the economic, legal, social, and technological, or other benefits of the project against its unavoidable environmental risks when determining whether to approve the project. No significant and unmitigated impacts have been identified for the proposed project; therefore, the County would not be required to adopt a Statement of Overriding Considerations pursuant to Section 15093 for this project.

Project Alternatives

Alternatives Considered but Rejected

Alternative Site

Section 15126.6(f)(2) of the CEQA Guidelines addresses alternative locations for a project. The key question and first step in the analysis is whether any of the significant effects of the proposed project would be avoided or substantially lessened by constructing the proposed project in another location. Only locations that would avoid or substantially lessen any of the significant effects of the project need to be considered for inclusion in the EIR. Further, CEQA Guidelines Section 15126.6(f)(1) states that among the factors that may be taken into account when addressing the feasibility of alternative locations are whether the project proponent can reasonably acquire, control or otherwise have access to the alternative site (or the site is already owned by the proponent).

The project applicant does not have control of an alternate site; if control were viable, the proponent would have to re-initiate the application process as a new project. Similar to the proposed project site, an alternate site would require environmental review once the proponent has prepared sufficient project description information. At present, the proponent does not have control of an alternate site. This alternative would be the most complex, costly, and time-consuming alternative to implement. It is unknown if the environmental impacts associated with this Alternative would be less than the proposed project because it would be speculative to evaluate an unsecured alternate site. This is primarily due to the fact that the project applicant does not have control of an alternate site. Therefore, an alternative site was eliminated from further consideration in this EIR.

Original Site Plan Submittal

The project applicant originally proposed to construct and operate a 100 MW solar energy facility with an integrated 100 MW BESS on approximately 531 acres (APNs 059-290-010, 059-300-015, and 059-300-017). Based on a biological reconnaissance survey of the 531-acre site, the following sensitive vegetation communities were found to be present on the western parcel (APN 059-209-010): arrow weed thickets, tamarisk thickets, and alkali weed – salt grass playas and sinks. Furthermore, one freshwater emergent wetland occurs on the western parcel. To minimize impacts on biological resources, the project applicant re-designed the project to remove the western parcel (APN 059-209-010). The western parcel would not be developed. This re-design reduced the original project site from 531 acres to 450 acres.

The original site plan on 531 acres would result in increased biological resources impacts and increased jurisdictional water impacts compared to the proposed project. Therefore, the County rejects to original site plan from further analysis.

Original Access Route for Heavy Construction Equipment

The project applicant's originally proposed access route for heavy construction equipment was via State Route 98 east to the East Highline Check of the All-American Canal bridge crossing to the project entrance. After coordination with the IID, IID determined that the bridge crossing would not be able to handle the weight of heavy construction equipment.

Although the use of the original access route would be a shorter distance to the project site and would result in less miles traveled, the County rejects the original access route from further analysis due to increased hazards and safety impacts.

Alternatives Evaluated

The environmental analysis for the proposed project evaluated the potential environmental impacts resulting from implementation of the proposed project, as well as alternatives to the project. The alternatives include Alternative 1: No Project/No Development and Alternative 2: Reduced Project Site. A detailed discussion of the alternatives considered is included in Chapter 7. Table ES-2 summarizes the impacts resulting from the proposed project and the identified alternatives.

Alternative 1: No Project/No Development Alternative

The CEQA Guidelines require analysis of the No Project Alternative (PRC Section 15126). According to Section 15126.6(e), "the specific alternative of 'no project' shall also be evaluated along with its impacts. The 'no project' analysis shall discuss the existing conditions at the time the Notice of Preparation is published, at the time environmental analysis is commenced, as well as what would be reasonably expected to occur in the foreseeable future if the project were not approved, based on current plans and consistent with available infrastructure and community services."

The No Project/No Development Alternative assumes that the project, as proposed, would not be implemented and the project site would not be developed.

The No Project/No Development Alternative would not meet a majority of the objectives of the project. Additionally, the No Project/No Development Alternative would not help California meet its statutory and regulatory goal of increasing renewable power generation, including GHG reduction goals of Senate Bill 32.

Alternative 2: Reduced Project Site

The purpose of this alternative is to reduce the size of the project site to minimize impacts on biological resources by increasing the setback of the project from sensitive vegetation communities and aquatic resources. Tamarisk thickets, identified by CDFW as a sensitive natural community, have been mapped on the northern parcel (APN 059-300-015) of the project site. Freshwater forested/shrub wetland, riparian habitat, and disturbed riparian habitat have also been mapped on the northern parcel of the project site. This alternative would remove the northern parcel (APN 059-300-015), thereby reducing the project site by 301 acres from 450 acres to 149 acres.

As shown in Table ES-2, this alternative would reduce impacts to agricultural resources, air quality, biological resources, cultural resources, hydrology/water quality, and utilities/service systems. Alternative 2 would meet most of the basic objectives of the proposed project and should remain under consideration. However, this alternative would make it more difficult to achieve the overall objective of providing a total of 100 MW of renewable solar energy, as there would be less area available for the placement of PV structures.



Environmentally Superior Alternative

The No Project/No Development Alternative would be considered the environmentally superior alternative, since it would eliminate all of the significant impacts identified for the project. However, CEQA Guidelines Section 15126.6(e)(2) states that “if the environmentally superior alternative is the No Project Alternative, the EIR shall also identify an environmentally superior alternative among the other alternatives.” As shown in Table ES-2, Alternative 2 would reduce impacts for the following environmental issue areas as compared to the proposed project: agricultural resources, air quality, biological resources, cultural resources, hydrology/water quality, and utilities/service systems. Therefore, Alternative 2 is considered the Environmentally Superior Alternative.

This page is intentionally blank.



Table ES-2. Comparison of Alternative Impacts to Proposed Project

Environmental Issue Area	Proposed Project	Alternative 1: No Project/No Development	Alternative 2: Reduced Project Site
Aesthetics and Visual Resources	Less than Significant	<i>CEQA Significance:</i> No Impact <i>Comparison to Proposed Project:</i> Less Impact	<i>CEQA Significance:</i> Less than Significant <i>Comparison to Proposed Project:</i> Similar Impact
Agricultural Resources	Less than Significant with Mitigation	<i>CEQA Significance:</i> No Impact <i>Comparison to Proposed Project:</i> Less Impact (Avoid)	<i>CEQA Significance:</i> Less than Significant with Mitigation <i>Comparison to Proposed Project:</i> Less Impact
Air Quality	Less than Significant with Mitigation	<i>CEQA Significance:</i> No Impact <i>Comparison to Proposed Project:</i> Less Impact	<i>CEQA Significance:</i> Less than Significant with Mitigation <i>Comparison to Proposed Project:</i> Less Impact
Biological Resources	Less than Significant with Mitigation	<i>CEQA Significance:</i> No Impact <i>Comparison to Proposed Project:</i> Less Impact (Avoid)	<i>CEQA Significance:</i> Less than Significant with Mitigation <i>Comparison to Proposed Project:</i> Less Impact
Cultural Resources	Less than Significant with Mitigation	<i>CEQA Significance:</i> No Impact <i>Comparison to Proposed Project:</i> Less Impact (Avoid)	<i>CEQA Significance:</i> Less than Significant with Mitigation <i>Comparison to Proposed Project:</i> Less Impact
Geology and Soils	Less than Significant with Mitigation	<i>CEQA Significance:</i> No Impact <i>Comparison to Proposed Project:</i> Less Impact (Avoid)	<i>CEQA Significance:</i> Less than Significant with Mitigation <i>Comparison to Proposed Project:</i> Similar Impact
GHG Emissions	Less than Significant	<i>CEQA Significance:</i> No Impact <i>Comparison to Proposed Project:</i> Less Impact	<i>CEQA Significance:</i> Less than Significant <i>Comparison to Proposed Project:</i> Similar Impact

Table ES-2. Comparison of Alternative Impacts to Proposed Project

Environmental Issue Area	Proposed Project	Alternative 1: No Project/No Development	Alternative 2: Reduced Project Site
Hazards and Hazardous Materials	Less than Significant	<i>CEQA Significance:</i> No Impact <i>Comparison to Proposed Project:</i> Less Impact	<i>CEQA Significance:</i> Less than Significant <i>Comparison to Proposed Project:</i> Similar Impact
Hydrology/ Water Quality	Less than Significant with Mitigation	<i>CEQA Significance:</i> No Impact <i>Comparison to Proposed Project:</i> Less Impact (Avoid)	<i>CEQA Significance:</i> Less than Significant with Mitigation <i>Comparison to Proposed Project:</i> Less Impact
Land Use/Planning	No Impact	<i>CEQA Significance:</i> No Impact <i>Comparison to Proposed Project:</i> Similar Impact	<i>CEQA Significance:</i> No Impact <i>Comparison to Proposed Project:</i> Similar Impact
Noise and Vibration	Less than Significant	<i>CEQA Significance:</i> No Impact <i>Comparison to Proposed Project:</i> Less Impact	<i>CEQA Significance:</i> Less than Significant <i>Comparison to Proposed Project:</i> Similar Impact
Transportation	Less than Significant	<i>CEQA Significance:</i> No Impact <i>Comparison to Proposed Project:</i> Less Impact	<i>CEQA Significance:</i> Less than Significant <i>Comparison to Proposed Project:</i> Similar Impact
Tribal Cultural Resources	Less than Significant	<i>CEQA Significance:</i> No Impact <i>Comparison to Proposed Project:</i> Less Impact	<i>CEQA Significance:</i> Less than Significant <i>Comparison to Proposed Project:</i> Similar Impact
Utilities/Service Systems	Less than Significant	<i>CEQA Significance:</i> No Impact <i>Comparison to Proposed Project:</i> Less Impact	<i>CEQA Significance:</i> Less than Significant <i>Comparison to Proposed Project:</i> Less Impact



1 Introduction

This environmental impact report (EIR) has been prepared to meet the requirements of the California Environmental Quality Act (CEQA) for purposes of evaluating the potential environmental impacts, mitigation measures, and alternatives associated with the proposed VEGA SES 4 Solar Energy Project. This EIR describes the existing environment that would be affected by, and the environmental impacts which could potentially result from the construction and operation of the proposed project as described in detail in Chapter 2.0 of this EIR.

1.1 Overview of the Proposed Project

The project site is located on approximately 450 acres of privately-owned land in the southernmost portion of Imperial County, California. The project site is between the U.S./Mexico international border and the All-American Canal, on the California side. The project site is proposed on two parcels (Assessor Parcel Numbers 059-300-015 and 059-300-017) that are contiguous with each other.

The proposed project consists of three primary components: 1) solar energy generation equipment and associated facilities including a substation and access roads (herein referred to as “solar energy facility”); 2) battery energy storage system (BESS); and 3) gen-tie line that would connect the proposed on-site substation to the point of interconnection at the existing Imperial Irrigation District’s (IID) 92-kV “P” line.

The proposed project involves the construction of a 100-megawatt (MW) alternating current (AC) photovoltaic (PV) solar energy facility with an integrated 100 MW battery storage system (not to exceed 200 MW) on approximately 450 acres of land. The project proposes to utilize either thin film or crystalline solar PV technology modules mounted either on fixed frames or horizontal single-axis tracker systems. The project would include electronic/electrical equipment, an on-site substation, access road(s) and fencing. The electrical energy produced by the project would be conducted through the project’s interconnection facilities to the proposed 92 kV generator intertie (gen-tie) line and delivered to the existing IID approved point of interconnection on the 92-kV “P” Line located immediately north of the project site and the All-American Canal.

1.1.1 Agency Roles and Responsibilities

This section identifies and summarizes federal, state, and local laws, policies, and regulations that are applicable to the project.

County of Imperial

Implementation of the project would involve the following approvals by the County of Imperial:

1. **Approval of Conditional Use Permit (CUP) – Solar Energy Facility.** Implementation of the project would require the approval of a CUP by the County to allow for the construction and operation of the proposed solar energy facility with an integrated BESS. The project site is located on two privately-owned legal parcels zoned Heavy Agriculture with a Renewable Energy Zone Overlay (A-3-RE). Pursuant to Title 9, Division 5, Chapter 9, the following uses are permitted in the A-3 zone subject to approval of a CUP from Imperial County:

i) Battery Storage Facility (must be connected to an existing electrical power generation plant such as solar, geothermal, wind, natural gas, or other renewable energy generator, as an accessory unit to said power plant).

oo) Major facilities relating to the generation and transmission of electrical energy, provided such facilities are not under State or Federal law, to [be] approved exclusively by an agency, or agencies of the State or Federal government, and provided such facilities shall be approved subsequent to coordination review of the Imperial Irrigation District for electrical matters, meeting the requirements in Division 17.

zz) Solar energy plants meeting the requirements in Division 17.

2. **Certification of the EIR.** After the required public review for the Draft EIR, the County will respond to written comments, edit the document, and produce a Final EIR to be certified by the Planning Commission and Board of Supervisors prior to making a decision on the project.

Subsequent ministerial approvals may include, but are not limited to:

- Grading and clearing permits
- Building permits
- Reclamation plan
- Encroachment permits
- Transportation permit(s)

Other Agencies Reviews and/or Consultations

The following agencies may be involved in reviewing and/or consultations with the project proponent as it relates to construction of the project:

Federal

UNITED STATES FISH AND WILDLIFE SERVICE

- The United States Fish and Wildlife Service (USFWS) enforces compliance with regulations related to special-status species or their habitat as required under the Federal Endangered Species Act (ESA).

UNITED STATES ARMY CORPS OF ENGINEERS

- Section 404 Permit (Clean Water Act [CWA]). The CWA establishes a program to regulate the discharge of dredge and fill material into waters of the U.S. including wetlands. Activities regulated under this program include fills for development, water resource projects (e.g., dams and levees), infrastructure development (e.g., highways and airports), and conversion of wetlands to uplands for farming and forestry. Either an individual 404b permit or authorization to use an existing USACE Nationwide Permit will need to be obtained if any portion of the construction requires fill into a river, stream, or stream bed that has been determined to be a jurisdictional waterway.



UNITED STATE BORDER PATROL

- The project applicant and U.S. Border Patrol will develop and enter into a Memorandum of Understanding (MOU) setting forth the project-related activities that may occur on an existing dirt road used by the U.S. Border Patrol.

State

CALIFORNIA DEPARTMENT OF FISH AND WILDLIFE (TRUSTEE AGENCY)

- The California Department of Fish and Wildlife (CDFW) is a Trustee Agency and enforces compliance with regulations related to California special-status species or their habitats as required under the California Endangered Species Act (CESA).

CALIFORNIA REGIONAL WATER QUALITY CONTROL BOARD

- **National Pollution Discharge Elimination System Construction General Permit Order No. 2009-009-DWQ.** Requires the applicant to file a public Notice of Intent to discharge stormwater and to prepare and implement a stormwater pollution prevention plan (SWPPP).
- **Jurisdictional Waters.** Agencies and/or project proponents must consult with the California Regional Water Quality Control Board (RWQCB) regarding, when applicable, regarding compliance with the CWA Section 401 Water Quality Certification or permitting under California Porter-Cologne Act.

Local

IMPERIAL COUNTY FIRE DEPARTMENT

- Review as part of the EIR process including the final design of the proposed fire system.

IMPERIAL COUNTY AIR POLLUTION CONTROL DISTRICT

- Review as part of the EIR process regarding consistency with the Imperial County Air Pollution Control District (ICAPCD) CEQA Air Quality Handbook, the final “Modified” 2009 8-hour Ozone Air Quality Management Plan, the State Implementation Plan for particulate matter less than 10 microns in diameter (PM₁₀) in the Imperial Valley, the State Implementation Plan (SIP) for particulate matter less than 2.5 microns in diameter (PM_{2.5}), and verification of Rule 801 compliance.

1.2 Relationship to Statutes, Regulations, and Other Plans

1.2.1 County of Imperial General Plan and Land Use Ordinance

The General Plan provides guidance on future growth in the County of Imperial. Any development in the County of Imperial must be consistent with the General Plan and Land Use Ordinance (Title 9, Division 10).

1.2.2 Renewables Portfolio Standard Program

Established in 2002 under Senate Bill (SB) 1078, California’s Renewables Portfolio Standard (RPS) was accelerated in 2006 under SB 107 by requiring that 20 percent of electricity retail sales be served by RE resources by 2010. RE sources include wind, geothermal, and solar. Subsequent

recommendations in California energy policy reports advocated a goal of 33 percent by 2020. On November 17, 2008, Governor Arnold Schwarzenegger signed Executive Order (EO) S-14-08 requiring that "... all retail sellers of electricity shall serve 33 percent of their load with RE by 2020." The following year, EO S-21-09 directed the California Air Resources Board (CARB), under its Assembly Bill (AB) 32 authority, to enact regulations to achieve the goal of 33 percent renewables by 2020.

In the ongoing effort to codify the ambitious 33 percent by 2020 goal, SB X12 was signed by Governor Brown, in April 2011. This new RPS preempts the CARB's 33 percent Renewable Electricity Standard and applies to all electricity retailers in the state including publicly owned utilities, investor-owned utilities, electricity service providers, and community choice aggregators. All of these entities had to adopt the new RPS goals of 20 percent of retail sales from renewables by the end of 2013, 25 percent by the end of 2016, and the 33 percent requirement being met by the end of 2020.

Governor Brown signed into legislation SB 350 in October 2015, which requires retail sellers and publicly owned utilities to procure 50 percent of their electricity from eligible RE resources by 2030. In 2018, SB 100 was signed by Governor Brown, codifying a goal of 60 percent renewable procurement by 2030 and 100 percent by 2045 Renewables Portfolio Standard.

1.2.3 Senate Bill 32

In August 2016, Governor Brown signed SB 32 and AB 197, which serve to extend California's GHG reduction programs beyond 2020. SB 32 amended the Health and Safety Code to include § 38566, which contains language to authorize CARB to achieve a statewide GHG emission reduction of at least 40 percent below 1990 levels by no later than December 31, 2030. SB 32 codified the targets established by Executive Order (EO) B-30-15 for 2030, which set the next interim step in the State's continuing efforts to pursue the long-term target expressed in EOs S-3-05 and B-30-15 of 80 percent below 1990 emissions levels by 2050.

1.2.4 Title 17 California Code of Regulations, Subchapter 10, Article 2, Sections 95100 et seq.

These CARB regulations implement mandatory GHG emissions reporting as part of the California Global Warming Solutions Act of 2006.

1.2.5 Federal Clean Air Act

The legal authority for federal programs regarding air pollution control is based on the 1990 Clean Air Act (CAA) Amendments. These are the latest in a series of amendments made to the CAA. This legislation modified and extended federal legal authority provided by the earlier Clean Air Acts of 1963, 1970, and 1977.

The Air Pollution Control Act of 1955 was the first Federal legislation involving air pollution. This Act provided funds for federal research in air pollution. The CAA of 1963 was the first Federal legislation regarding air pollution control. It established a federal program within the U.S. Public Health Service and authorized research into techniques for monitoring and controlling air pollution. In 1967, the Air Quality Act was enacted in order to expand Federal government activities. In accordance with this law, enforcement proceedings were initiated in areas subject to interstate air pollution transport. As part of these proceedings, the Federal government for the first time conducted extensive ambient monitoring studies and stationary source inspections.

The Air Quality Act of 1967 also authorized expanded studies of air pollutant emission inventories, ambient monitoring techniques, and control techniques.

1.2.6 Imperial County Air Pollution Control District

The ICAPCD enforces rules and regulations regarding air emissions associated with various activities, including construction and farming, and operational activities associated with various land uses, in order to protect the public health.

1.2.7 Federal Clean Water Act (33 United States Code Sections 1251–1387)

The Federal Water Pollution Control Act (33 United States Code [USC] §§1251-1387), otherwise known as the CWA, is a comprehensive statute aimed at restoring and maintaining the chemical, physical and biological integrity of the nation's waters. Enacted originally in 1948, the Act was amended numerous times until it was reorganized and expanded in 1972. It continues to be amended almost every year. Primary authority for the implementation and enforcement of the CWA rests with the U.S. Environmental Protection Agency (EPA). In addition to the measures authorized before 1972, the Act authorizes water quality programs, requires federal effluent limitations and state water quality standards, requires permits for the discharge of pollutants into navigable waters, provides enforcement mechanisms, and authorizes funding for wastewater treatment works construction grants and state revolving loan programs, as well as funding to states and tribes for their water quality programs. Provisions have also been added to address water quality problems in specific regions and specific waterways.

Important for wildlife protection purposes are the provisions requiring permits to dispose of dredged and fill materials into navigable waters. Permits are issued by the United States Army Corps of Engineers (USACE) under guidelines developed by EPA pursuant to Section 404 of the CWA.

1.2.8 Federal Clean Water Act and California Porter-Cologne Water Quality Control Act

The project is located within the Colorado River Basin RWQCB, Region 7. The CWA and the California Porter-Cologne Water Quality Control Act require that Water Quality Control Plans (more commonly referred to as Basin Plans) be prepared for the nine state-designated hydrologic basins in California. The Basin Plan serves to guide and coordinate the management of water quality within the region.

1.2.9 Federal Endangered Species Act

The ESA (16 USC 1531-1544) provides protection for plants and animals whose populations are dwindling to levels that are no longer sustainable in the wild. The Act sets out a process for listing species, which allows for petition from any party to list a plant or animal. Depending on the species, USFWS or the National Marine Fisheries Service (NMFS) will determine whether listing the species is warranted. If it is warranted, the species will be listed as either threatened or endangered. The difference between the two categories is one of degree, with endangered species receiving more protections under the statute.

1.2.10 National Historic Preservation Act

Federal regulations (36 Code of Federal Regulations [CFR] Part 800.2) define historic properties as "any prehistoric or historic district, site, building, structure, or object included, or eligible for inclusion in, in the National Register of Historic Places (NRHP)." The term "cultural resource" is used to denote a historic or prehistoric district, site, building, structure, or object, regardless of whether it is eligible for the NRHP.

1.2.11 California Endangered Species Act

CESA is enacted through Government Code Section 2050. Section 2080 of the California Fish and Game Code (FGC) prohibits "take" of any species that the commission determines to be an endangered species or a threatened species. Take is defined in Section 86 of the FGC as "hunt, pursue, catch, capture, or kill, or attempt to hunt, pursue, catch, capture, or kill."

CESA allows for take incidental to otherwise lawful development projects. CESA emphasizes early consultation to avoid potential impacts to rare, endangered, and threatened species and to develop appropriate mitigation planning to offset project-caused losses of listed species populations and their essential habitats.

1.2.12 California Lake and Streambed Program (Fish and Game Code Section 1602)

CDFW is responsible for conserving, protecting, and managing California's fish, wildlife, and native plant resources. To meet this responsibility, the FGC (Section 1602) requires an entity to notify CDFW of any proposed activity that may substantially modify a river, stream, or lake.

1.3 Purpose of an EIR

The purpose of an EIR is to analyze the potential environmental impacts associated with a project. CEQA (Section 15002) states that the purpose of CEQA is to: (1) inform the public and governmental decision makers of the potential, significant environmental impacts of a project; (2) identify the ways that environmental damage can be avoided or significantly reduced; (3) prevent significant, avoidable damage to the environment by requiring changes in projects through the use of alternatives or mitigation measures when the governmental agency finds the changes to be feasible; and (4) disclose to the public the reasons why a governmental agency approved the project in the manner the agency chose if significant environmental effects are involved.

1.4 EIR Process

1.4.1 Availability of Reports

This Draft EIR has been distributed to various federal, state, regional, local agencies and interested parties for a 45-day public review period, from November 22, 2022, through January 10, 2023, in accordance with Section 15087 of the CEQA Guidelines. This Draft EIR and documents incorporated by reference are available for public review at the County of Imperial Planning and Development Services Department, 801 Main Street, El Centro, California 92243. Documents may be reviewed during regular business hours.



David Black, Planner IV
County of Imperial, Planning and Development Services Department
801 Main Street
El Centro, California 92243

Comments received during the public review period of the Draft EIR will be reviewed and responded to in the Final EIR. The Final EIR will then be reviewed by the Imperial County Planning Commission and Board of Supervisors as a part of the procedure to adopt the EIR. Additional information on this process may be obtained by contacting the County of Imperial Planning and Development Services Department at (442) 265-1736.

1.4.2 Public Participation Opportunities/Comments and Coordination

Notice of Preparation

The County of Imperial issued a notice of preparation (NOP) for the preparation of an EIR for the VEGA SES 4 Solar Energy Project on May 4, 2021. The NOP was distributed to city, county, state, and federal agencies, other public agencies, and various interested private organizations and individuals in order to define the scope of the EIR. The NOP was also published in the Imperial Valley Press on May 4, 2021, and in the Calexico Chronicles on May 6, 2021. The purpose of the NOP was to identify public agency and public concerns regarding the potential impacts of the project, and the scope and content of environmental issues to be addressed in the EIR. Correspondence in response to the NOP was received from the following entities and persons:

- Imperial Irrigation District
- Imperial County Air Pollution Control District
- Imperial County Department of Public Works
- Native American Heritage Commission

The comments submitted on the NOP during the public review and comment period are included as Appendix A to this EIR.

Scoping Meeting and Environmental Evaluation Committee

During the NOP public review period, the VEGA SES 4 Solar Energy Project was discussed as an informational item at the County's Environmental Evaluation Committee meeting on May 13, 2021.

Additionally, a virtual scoping meeting for the general public as well public agencies was held on May 13, 2021, at 6:00 p.m., to further obtain input as to the scope of environmental issues to be examined in the EIR. The NOP, which included the scoping meeting date and location, was published in the Imperial Valley Press on May 4, 2021, and in the Calexico Chronicles on May 6, 2021. A virtual meeting was held by the Imperial County Planning & Development Services Department. At the scoping meeting, members of the public were invited to ask questions regarding the proposed project and the environmental review process, and to comment both verbally and in writing on the scope and content of the EIR. No written or verbal comments were received during the scoping meeting.

1.4.3 Environmental Topics Addressed

Based on the analysis presented in the NOP and the information provided in the comments to the NOP, the following environmental topics are analyzed in this EIR.

- Aesthetics
- Agriculture Resources
- Air Quality
- Biological Resources
- Cultural Resources
- Geology and Soils
- GHG Emissions
- Hazards and Hazardous Materials
- Hydrology/Water Quality
- Land Use and Planning
- Noise and Vibration
- Transportation
- Tribal Cultural Resources
- Utilities/Service Systems (Water Supply)

Eliminated from Further Review in Notice of Preparation

The initial study (IS)/NOP completed by the County (Appendix A of this EIR) determined that environmental effects to Forestry Resources, Energy, Mineral Resources, Population/Housing, Public Services, Recreation, Utilities (Wastewater, Stormwater, and Solid Waste), and Wildfire would not be potentially significant. Therefore, these impacts are not addressed in this EIR; however, the rationale for eliminating these issues is discussed in Chapter 6.0, Effects Found Not Significant.

1.4.4 Areas of Controversy and Issues to be Resolved

Section 15123(b)(2) of the CEQA Guidelines requires that an EIR identify areas of controversy known to the Lead Agency, including issues raised by other agencies and the public as well as issues to be resolved. A primary issue associated with this solar farm project, and other solar facility projects that are proposed in the County, is the corresponding land use compatibility and fiscal/economic impacts to the County. Through the environmental review process for this project, other areas of concern and issues to be resolved include impacts on IID drains, project site access for construction workers, construction vehicles and equipment, and operational requirements (e.g., periodic maintenance and emergency response access), and U.S./Mexico border patrol operations.

1.4.5 Document Organization

The structure of the Draft EIR is identified below. The Draft EIR is organized into 11 chapters, including the Executive Summary.

- The **Executive Summary** provides a summary of the proposed project, including a summary of project impacts, mitigation measures, and project alternatives.
- **Chapter 1 Introduction** provides a brief introduction of the proposed project; relationship to statutes, regulations and other plans; the purpose of an EIR; public participation opportunities; availability of reports; and comments received on the NOP.
- **Chapter 2 Project Description** provides a description of the VEGA SES 4 Solar Energy Facility Project. This chapter also defines the goals and objectives of the proposed project, provides details regarding the individual components that together comprise the project, and identifies the discretionary approvals required for implementation of the project.
- **Chapter 3 Environmental Analysis** provides a description of the existing environmental setting and conditions, an analysis of the environmental impacts of the project for the following

environmental issues: aesthetics; agricultural resources; air quality; biological resources; cultural resources; geology and soils; GHG emissions; hazards and hazardous materials; hydrology/water quality; land use and planning; noise and vibration; transportation; tribal cultural resources; and utilities/service systems. This chapter also identifies mitigation measures to address potential impacts to the environmental issues identified above.

- **Chapter 4 Analysis of Long-Term Effects** provides an analysis of growth inducing impacts, significant irreversible environmental changes, and unavoidable adverse impacts.
- **Chapter 5 Cumulative Impacts** discusses the impact of the proposed project in conjunction with other planned and future development in the surrounding areas.
- **Chapter 6 Effects Found Not to be Significant** lists all the issues determined to not be significant as a result of the preparation of this EIR.
- **Chapter 7 Alternatives** analyzes the alternatives to the proposed project.
- **Chapter 8 References** lists the data references utilized in preparation of the EIR.
- **Chapter 9 EIR Preparers and Organizations Contacted** lists all the individuals and companies involved in the preparation of the EIR, as well as the individuals and agencies consulted and cited in the EIR.

This page is intentionally blank.



2 Project Description

Chapter 2 provides a description of the VEGA SES 4 Solar Energy Project. This chapter also defines the goals and objectives of the proposed project, provides details regarding the individual components that together comprise the project, and identifies the discretionary approvals required for project implementation.

The proposed project consists of three primary components: 1) solar energy generation equipment and associated facilities including a substation and access roads (herein referred to as “solar energy facility”); 2) battery energy storage system (BESS); and 3) gen-tie line that would connect the proposed on-site substation to the point of interconnection at the existing IID 92-kV “P” line. The solar energy facility, BESS and gen-tie are collectively referred to as the “proposed project” or “project.”

2.1 Project Location

The project site is located on approximately 450 acres of privately-owned land in the southernmost portion of Imperial County, California (Figure 2-1). The project site is between the U.S./Mexico international border and the All-American Canal, on the California side. It is approximately 10 miles east of the City of Calexico in Sections 10, 11, 14, 15, and 16 within Township 17 South, and Range 16 East of the San Bernardino Base and Meridian of the Bonds Corner topographic 7.5-minute quadrangle. The irregular shaped project site is bound by undeveloped land, portions of which have been disturbed associated with previous agricultural-related activities to the west and east, the All-American Canal running southwest on the northern border of the project site, and the U.S./Mexico international border to the south. The project site is currently characterized by flat and undeveloped land, portions of which have been disturbed associated with previous agricultural-related activities.

2.1.1 Solar Energy Facility

As depicted on Figure 2-2, the solar energy facility site is proposed on two parcels that are contiguous with each other. Table 2-1 identifies the individual assessor parcel numbers (APN) with their respective acreage and zoning.

Table 2-1. Solar Energy Facility Site Assessor Parcel Numbers, Acreages, and Zoning

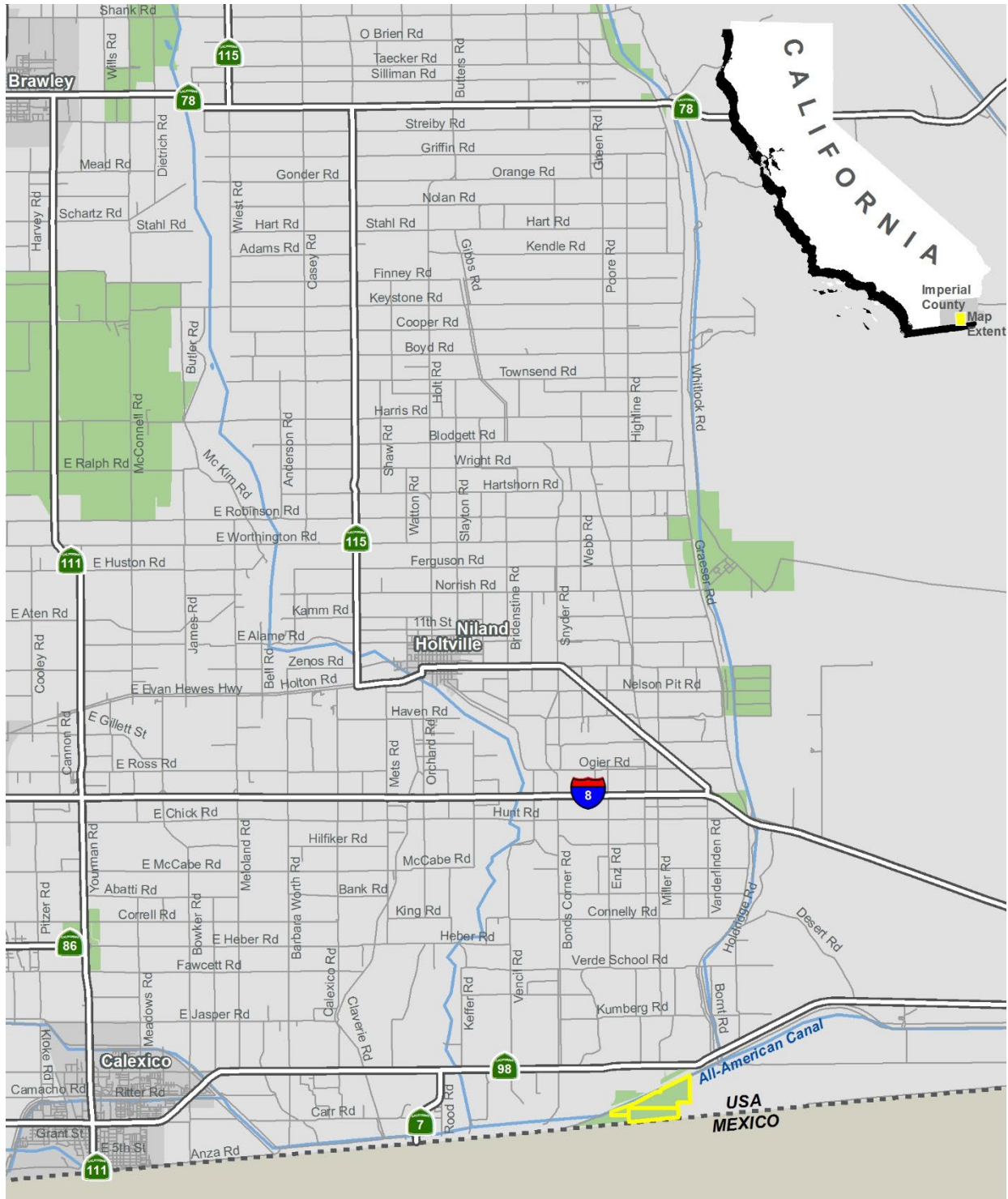
APN	Acreage	Zoning
059-300-015	301.73	A-3-RE
059-300-017	148.88	A-3-RE
Total Gross Acres	450.61	--

APN = assessor parcel number; A-3-RE = Heavy Agriculture with a Renewable Energy Zone Overlay

2.1.2 Battery Energy Storage System

The project includes a BESS within the northeastern portion of the solar energy facility site (APN 059-300-015).

Figure 2-1. Regional Location



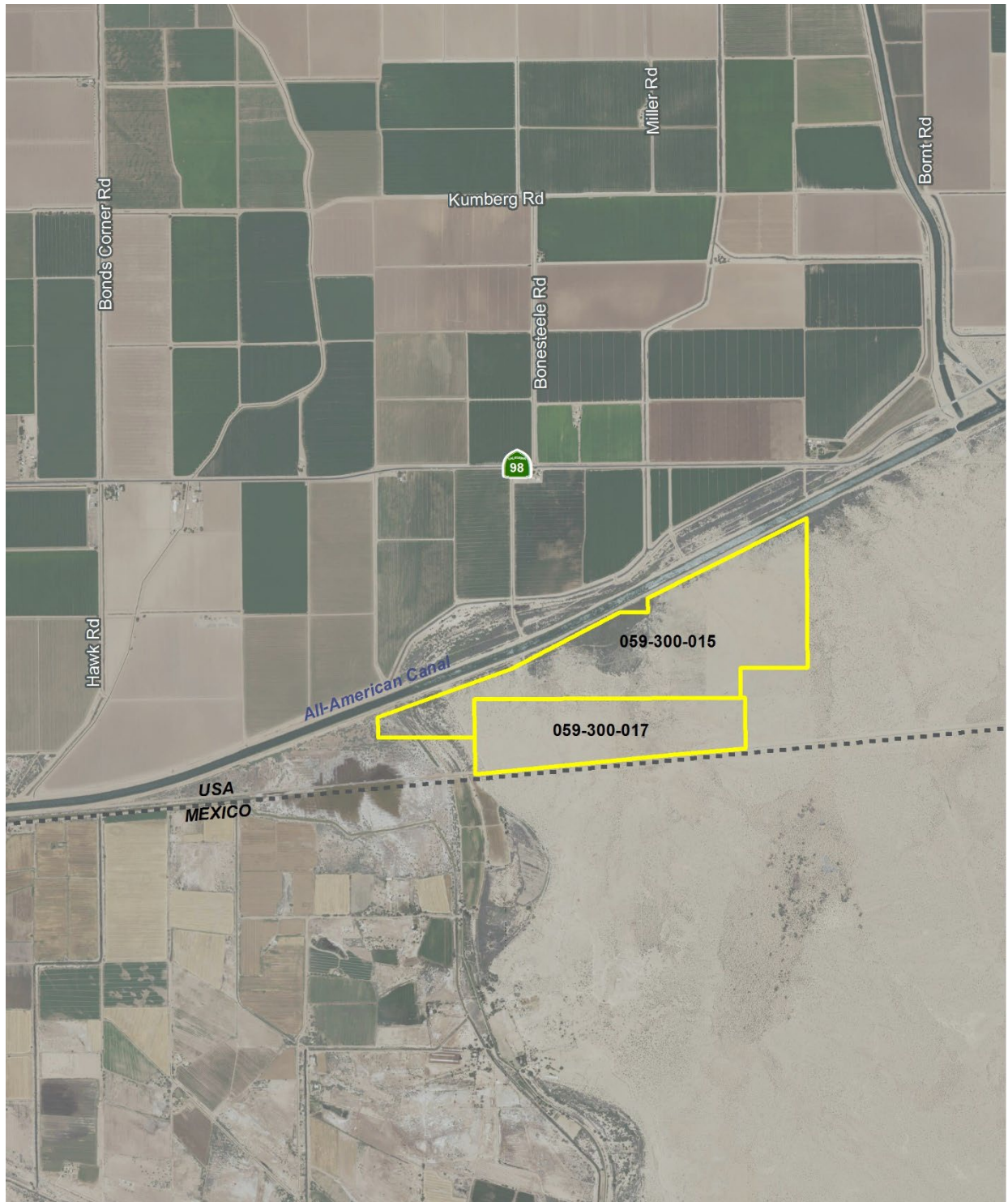
Legend

- VEGA SES 4 Project Area
- Renewable Energy Overlay Zone



0 Miles 2

Figure 2-2. Project Site



Legend

 VEGA SES 4 Project Parcels



0 Feet 2,000

2.1.3 Gen-Tie Line

The electrical energy produced by the project would be conducted through the project's interconnection facilities to the proposed 92 kV generator intertie (gen-tie) line and delivered to the existing IID approved point of interconnection (POI) on the 92 kV "P" Line located immediately north of the project site and the All-American Canal.

2.1.4 Renewable Energy Overlay Zone

In 2016, the County adopted the Imperial County Renewable Energy and Transmission Element, which includes an RE Zone (RE Overlay Map). This General Plan element was created as part of the California Energy Commission Renewable Energy Grant Program to amend and update the County's General Plan to facilitate future development of renewable energy projects.

The County Land Use Ordinance, Division 17, includes the RE Overlay Zone, which authorizes the development and operation of renewable energy projects with an approved CUP. The RE Overlay Zone is concentrated in areas determined to be the most suitable for the development of renewable energy facilities while minimizing the impact on other established uses. CUP applications proposed for specific renewable energy projects not located in the RE Overlay Zone would not be allowed without an amendment to the RE Overlay Zone.

As shown on Figure 2-1, the project site is located within the RE Overlay Zone. Therefore, no General Plan Amendment or Rezone would be required to implement the proposed project.

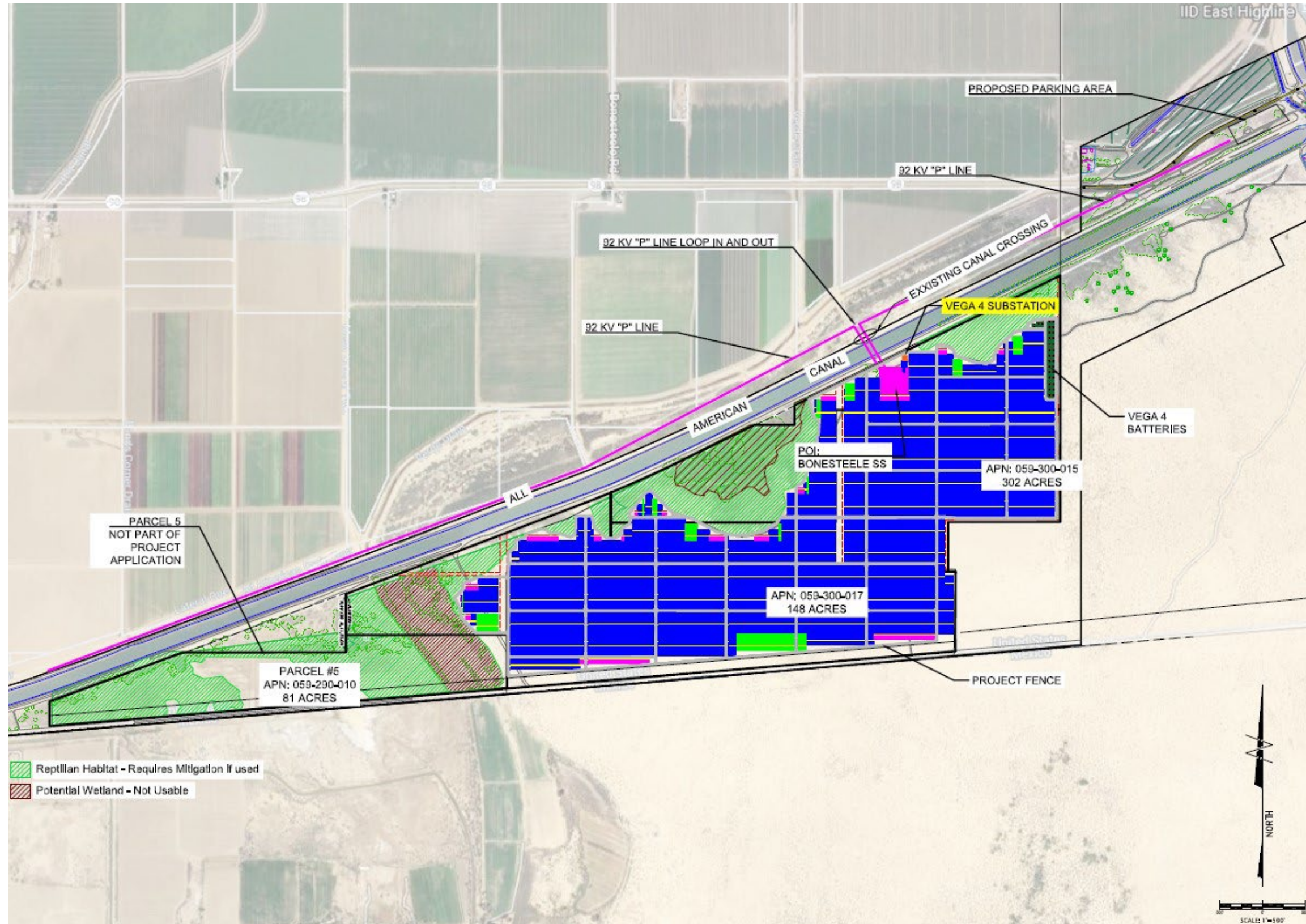
2.2 Project Objectives

- Construct and operate a solar energy facility capable of producing up to 100-megawatt (MW) alternating current (AC) of electricity to assist the State of California in achieving its 60 percent renewable portfolio standard by 2030.
- Provide a 100 MW energy BESS, that would accommodate and store the power generated by the project so that the facility can continue to provide renewable energy during non-daylight hours.
- Interconnect directly to IID's existing electrical transmission system.
- Help California meet its statutory and regulatory goal of increasing renewable power generation, including greenhouse gas reduction goals of Senate Bill 32.
- Minimize and mitigate any potential impact to sensitive environmental resources within the project area.

2.3 Project Characteristics

The proposed project involves the construction and operation of a 100 MW AC PV solar energy facility with an integrated 100 MW BESS (not to exceed 200 MW) on approximately 450 acres of land. As shown in Figure 2-3, the project site would be developed with a ground mounted PV solar power generating system, supporting structures, on-site substation, BESS, interconnection facilities, and internal access roads. The project would employ the use of PV power systems to convert solar energy into electricity using non-reflective technology.

Figure 2-3. Site Plan



This page is intentionally blank.

2.3.1 Photovoltaic Panels/Solar Arrays

PV solar cells convert sunlight directly into direct current electricity. The process of converting light (photons) to electricity (voltage) in a solid-state process is called the photovoltaic effect. A number of individual PV cells are electrically arranged and connected into solar PV modules, sometimes referred to as solar panels.

The project proposes to utilize either thin film or crystalline solar photovoltaic (PV) technology modules mounted either on fixed frames or horizontal single-axis tracker (HSAT) systems.

The fixed frame PV module arrays would be mounted on racks that would be supported by driven piles. The depth of the piles would be dependent on the recommendations of the geotechnical report prepared for the project. The fixed-frame racks would be secured at a fixed tilt of 20-30 degrees from horizontal facing a southerly direction. Current project designs would have individual PV modules, mounted two high on a fixed frame, providing a two-foot ground clearance and resulting in the tops of the panels at approximately 7.5 feet above the ground. The fixed PV modules would be arranged in arrays spaced approximately 15 to 25 feet apart (pile-to-pile) to maximize performance and to allow access for panel cleaning. These arrays would be separated from each other and the perimeter security fence by up to 30-foot-wide interior roads.

If HSAT technology is used, the PV modules would rotate around the north-south HSAT axis so that the PV modules would continue to face the sun as the sun moves across the sky throughout the day. The PV modules would reach their maximum height (up to 9 feet above the ground, depending on the final design) at both sunrise and sunset, when the HSAT is rotated to point the modules at the rising or setting sun. At noon, or when stowed during high winds, when the HSAT system is rotated so that the PV modules are horizontal, the nominal height would be about 6 feet above the ground, depending on the final design.

The individual PV systems would be arranged in large arrays by placing them in columns spaced approximately 10 feet apart to maximize operational performance and to allow access for panel cleaning and maintenance. Current project designs would have individual HSAT PV modules, each approximately two feet wide by four feet long (depending on the specific PV technology selected), mounted on a frame which is attached to an HSAT system. The HSAT arrays would be separated from each other and the perimeter security fence by up to 30-foot-wide roads, consistent with Imperial County Fire Department emergency access requirements.

2.3.2 Electrical Power System

Electricity generated by the PV modules would be collected by a direct current (DC) collection system routed underground in trenches. This DC power would be delivered to one of the pad-mounted inverters in weatherproof enclosures located within the arrays. The inverters would convert the DC power to three-phase alternating current (AC). The inverters could be connected to AC interconnection facilities which, if needed, would raise the voltage to 34.5 kilovolt (kV), or the interconnection voltage selected by the project. Underground or overhead 12.5 kV or 34.5 kV collection lines would transmit the electricity to the new project substation.

2.3.3 Interconnection Facilities

A new substation would be constructed on approximately two acres on the north-central portion of the project site. The substation would take the 34.5 kV power from the project and increase the voltage of

the electricity to 92 kV, where it would feed into the interconnection switching station for metering and delivery to the IID 92 kV “P” Line. The substation would include a transformer, circuit breakers, disconnect switches, and microwave or other communication facilities.

A new interconnection switching station would be constructed on the north-central portion of the project site, immediately adjacent to the substation. The switching station would include circuit breakers, switches, overhead bus work, protective relay equipment and an electrical control building. The switching station would operate at 92 kV and be equipped with two circuit breakers, allowing for looping in of the IID 92 kV “P” transmission line as well as connection to the project’s gen-tie line. The substation and switching station would be connected via a single overhead 92 kV line. The switching station would be enclosed within its own fence.

To connect the project’s interconnection facilities, the medium voltage power produced by the project would be conveyed underground, or above ground where necessary, to cross over any sensitive site features. The design of the project’s interconnection facilities would meet all necessary utility standards and requirements. As required, surge arrestors would be used to protect facilities and auxiliary equipment from lightning strikes or other disturbances. Distribution from the site would be via an overhead connection.

2.3.4 Gen-Tie

The electrical energy produced by the project would be conducted through the project’s interconnection facilities to the proposed 92 kV generator intertie (gen-tie) line and delivered to the existing IID approved POI on the 92 kV “P” Line. As shown in Figure 2-3, the project’s proposed 92 kV gen-tie would extend across the All-American Canal from the proposed project substation to the existing IID 92 kV “P” Line located immediately north of the canal. The height of the proposed gen-tie transmission structures would be 60 feet. The A-3 zone allows a maximum height limit of 120 feet for non-residential structures.

2.3.5 Battery Energy Storage System

The proposed BESS is proposed on approximately two acres on the northeast portion of the project site. The BESS would have a storage capacity of 100 MW (not exceed 200 MW). The BESS would consist of either lithium ion or flow batteries. The batteries will either be housed in storage containers or buildings fitted with HVAC and fire suppression systems as necessary, depending on the final selection of battery technology. Inside the housing the batteries will be placed on racks, the orientation of which depends on the type of housing. Underground trenches with conduits will be used to connect the batteries to the control and monitoring systems, and inverters to convert the PV produced DC power to AC power.

2.3.6 Security

Six-foot high security fencing would be installed around the perimeter of the project site at the commencement of construction and site access would be limited to authorized site workers. The project fence on the south would be setback a minimum of 180 feet from the U.S./Mexico international border. A motion detection system and closed-circuit camera system may also be installed. The site would be remotely monitored 24 hours per day, 7 days per week. In addition, routine unscheduled security rounds may be made by the security team monitoring the site security.

2.3.7 Site Access

The project site would be accessed via the following:

- **Worker Access:** Workers would utilize an existing driveway off State Route 98, park their vehicles in a designated staging/parking area north of the All-American Canal, and then walk across the All-American Canal at an existing crossing east of the project site (Figure 2-4 and Figure 2-5). No vehicles or construction vehicles are allowed to travel across this existing crossing. Designated shuttles would pick up workers at the south end of the crossing, and then travel west for approximately one mile along an existing dirt road to the project site.
- **Heavy Construction Equipment Access:** Vendors and heavy construction equipment would exit south from Interstate 8 onto Gordon Wells Road approximately 20 miles east of the project site, then travel west along an existing dirt road paralleling the U.S./Mexico Border (Figure 2-6). See Section 2.4.2 for a detailed description of this access route for heavy construction equipment. The applicant has entered into a Memorandum of Understanding with the U.S. Border Patrol setting forth the project-related activities that may occur on this existing dirt road used by the U.S. Border Patrol (see Section 2.7.3 for a detailed discussion).

The project driveways would be provided with a minimum of 30-foot double swing gates with “Knox Box” for keyed entry. Emergency response personnel would be provided with manual override capability in order to access the site facility.

To accommodate emergency access, PV panels would be spaced to maintain proper clearance. Internal access roads, up to 30-foot wide, would be constructed along the perimeter fence and solar panels to facilitate vehicle access and maneuverability for emergency unit vehicles.

2.3.8 Fire Protection/Fire Suppression

Fire protection systems for battery systems would be designed in accordance with California Fire Code and would take into consideration the recommendations of the National Fire Protection Association (NFPA) 855.

Fire suppression agents such as Novec 1230 or FM 2000, or water may be used as a suppressant. In addition, fire prevention methods would be implemented to reduce potential fire risk, including voltage, current, and temperature alarms. Energy storage equipment would comply with Underwriters Laboratory (UL)-95401 and test methods associated with UL-9540A. The project would include lithium-ion batteries. For lithium-ion batteries storage, a system would be used that would contain the fire event and encourage suppression through cooling, isolation, and containment. Suppressing a lithium-ion (secondary) battery is best accomplished by cooling the burning material. A gaseous fire suppressant agent (e.g., 3M™ Novec™ 1230 Fire Protection Fluid or similar) and an automatic fire extinguishing system with sound and light alarms would be used for lithium-ion batteries.

To mitigate potential hazards, redundant separate methods of failure detection would be implemented. These would include alarms from the Battery Management System (BMS), including voltage, current, and temperature alarms. Detection methods for off gas detection would be implemented, as applicable. These are in addition to other potential protective measures such as ventilation, overcurrent protection, battery controls maintaining batteries within designated parameters, temperature and humidity controls, smoke detection, and maintenance in accordance with manufacturer guidelines. Remote alarms would be installed for operations personnel as well as emergency response teams in addition to exterior hazard lighting. In addition, an Incidence Response Plan would be implemented. Additionally, the project applicant would contribute its proportionate share

for purchase of any fire-suppression equipment, if determined warranted by the County fire department for the proposed project.

2.4 Site Construction

2.4.1 Construction Activities

Construction activities would primarily involve demolition and grubbing, grading of the project site to establish access roads and pads for electrical equipment, trenching for underground electrical collection lines, and the installation of solar equipment and security fencing. Construction is estimated to take 12-18 months and would begin in late 2022 or 2023.

Dust generated during construction would be controlled by watering and, as necessary, the use of other dust suppression methods and materials accepted by the Imperial County Air Pollution Control District (ICAPCD).

A temporary, portable construction supply container would be located at the project site at the beginning of construction and removed at the end of construction.

The number of on-site construction workers for the solar facility is not expected to exceed 150 workers at any time. The number of on-site construction workers for the BESS and substation is not expected to exceed 100 workers at any one time. Onsite parking would be provided for all construction workers.

2.4.2 Heavy Construction Equipment Access

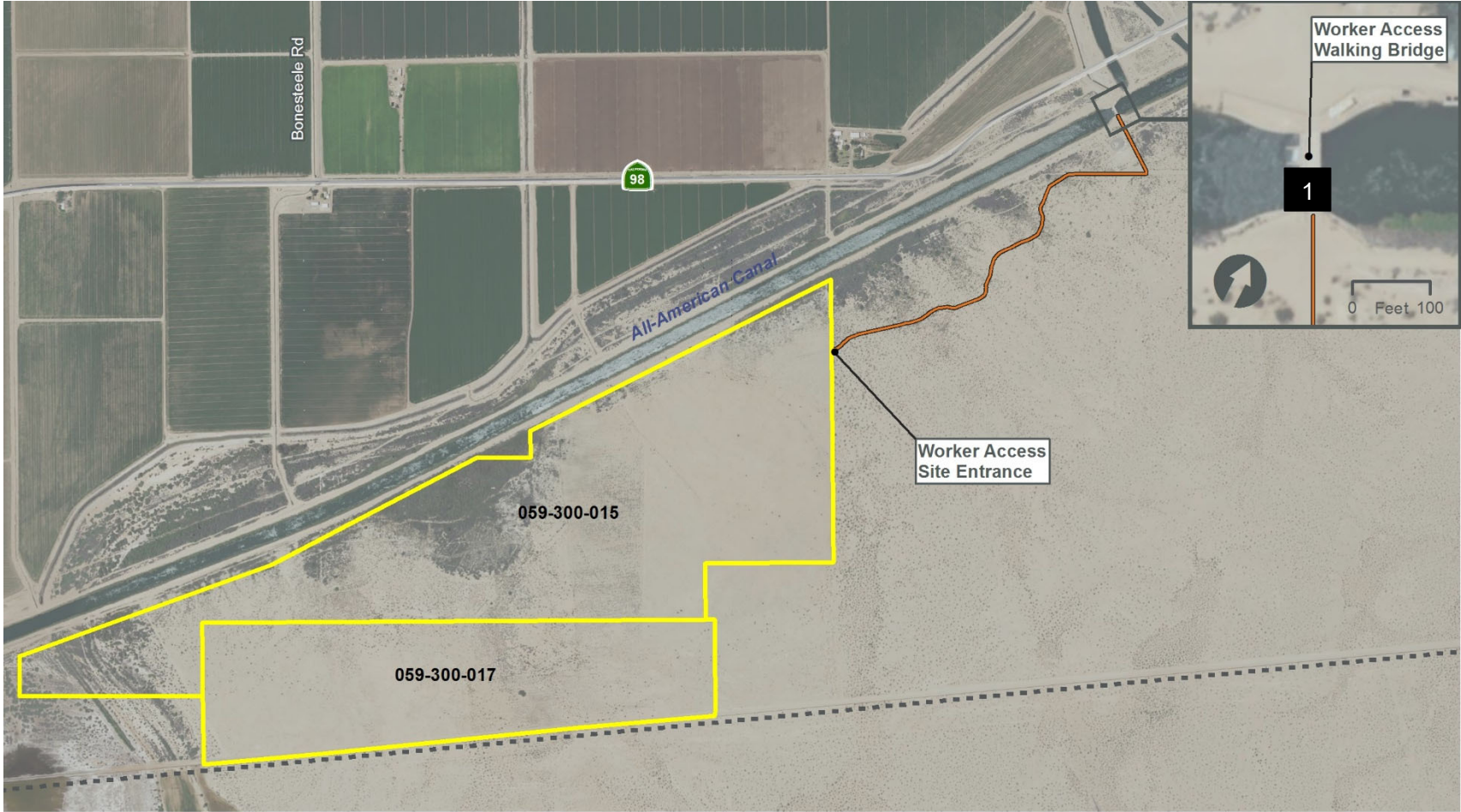
Following discussions with the IID, it was determined heavy construction vehicles would cross the All-American Canal at Gordon Wells Road located approximately 20 miles east of the project site (Figure 2-6). Access for heavy construction vehicles to and from the project site requires crossing the All-American Canal, via two existing bridges (Figure 2-7), located along Gordon Wells Road. Gordon Wells Road has an interchange with I-8. The bridges over the canal were constructed in 2009. The bridges are rated as open with no restrictions and have a “Good” condition rating.

An estimated two trucks would arrive at the project site each day during the first few weeks of construction of the solar facility.

2.4.3 Parking and Staging Areas

As described above, workers would utilize an existing driveway off State Route 98 (Figure 2-4) and then park their vehicles in a designated staging/parking area, approximately 3.5 acres in size, north of the All-American Canal (Figure 2-3). The staging/parking area will need to be improved to facilitate access and minimize parking conflicts. Dust would be controlled by watering and, as necessary, the use of other dust suppression methods and materials accepted by the ICAPCD.

Figure 2-4. Construction Worker Access



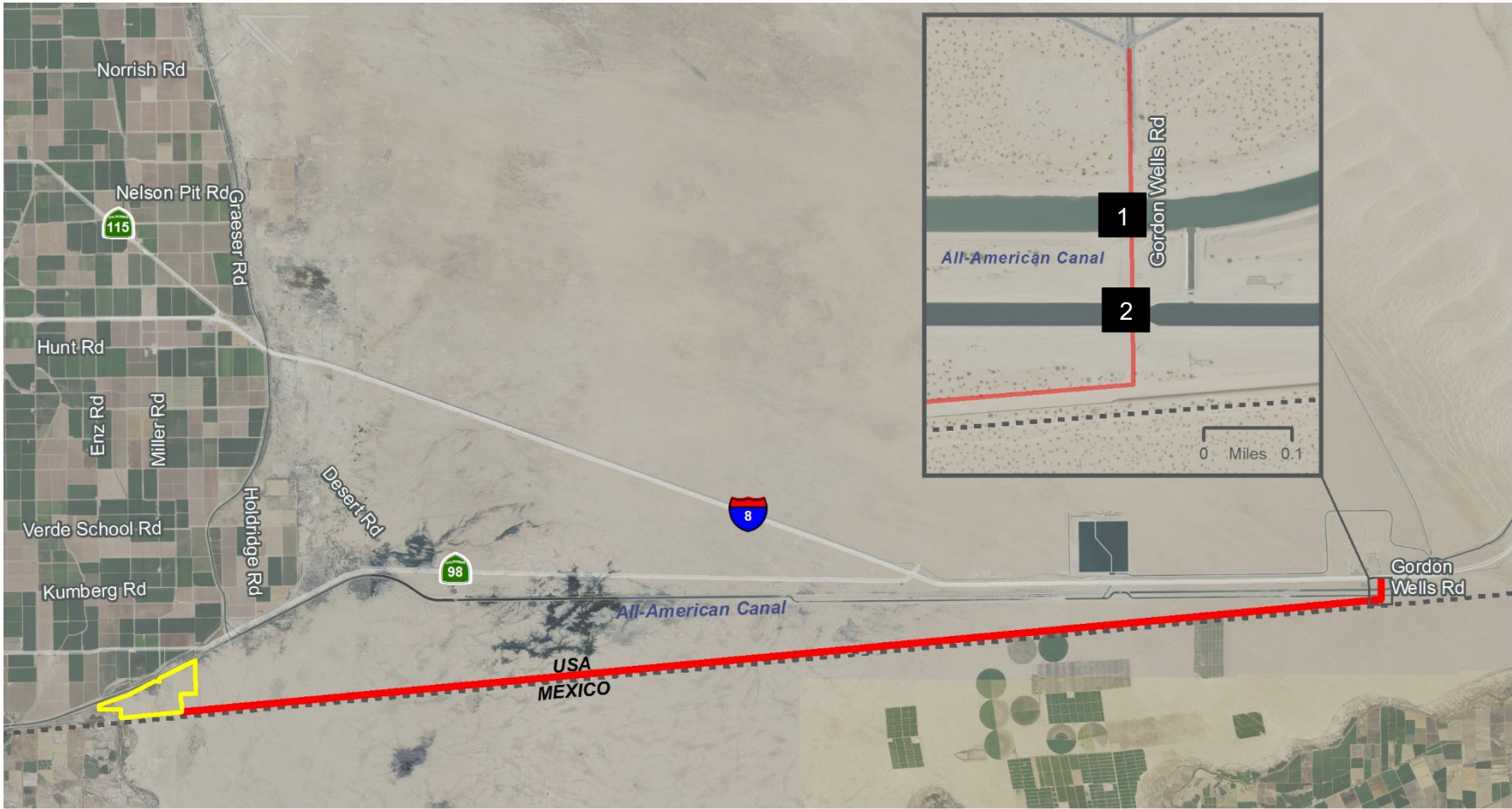
- Legend
- Project Area
 - Proposed Worker Access Road
 - Bridge Crossing Location – see Figure 2-5 for photo



Figure 2-5. Bridge Crossing – Pedestrian Access Only



Figure 2-6. Proposed Heavy Construction Equipment Access



Legend

- Proposed Heavy Construction Equipment Access
- ▭ Project Location
- # Bridge Crossing Locations – see Figure 2-7 for photos



This page is intentionally blank.

Figure 2-7. Proposed Bridge Crossings over All-American Canal



Bridge over north American Canal



Bridge over south American Canal

2.4.4 Water Use

Water for construction, primarily for dust control, would be obtained from local IID irrigation canals or laterals in conformance with IID rules and regulations for municipal, commercial, and industrial (MCI) temporary water use. Water would be picked up from the All-American Canal and delivered to the construction location by a water truck which would be capable of carrying approximately 4,000 gallons per load. It is estimated that up to 183 acre-feet of water would be needed for site grading and dust control over the expected construction period.

2.5 Operations and Maintenance

Once construction is completed, the facility would be remotely operated, controlled and monitored and with no requirement for daily on-site employees. Security personnel may conduct unscheduled security rounds and would be dispatched to the project site in response to a fence breach or other alarm.

Up to two to three people would be contracted (part-time) to perform all routine and emergency operational and maintenance activities. Such activities include inspections, equipment servicing, site and landscape clearing, and periodic washing of the PV modules if needed (up to two times per year) to maintain power generation efficiency. The amount of water needed for solar panel washing is estimated at approximately 5 AF per washing, with up to two washings per year, or a total of up to 10 AF per year. Vegetation growing on the solar energy facility site would periodically (approximately every 3 months) be removed manually and/or treated with herbicides.

2.5.1 Water Use

Water for washing the PV modules would be purchased from the IID and delivered to the project site by water trucks. The volume of water to be used for PV module washing and dust control is estimated at up to 10-acre feet per year.

2.6 Restoration of the Project Site

Electricity generated by the facility could be sold under the terms of a PPA with a power purchaser (i.e., utility service provider). At the end of the PPA term, the owner of the facility may choose to enter into a subsequent PPA, update technology and re-commission, or decommission and remove the generating facility and its components. Upon decommissioning, the site could be converted to other uses in accordance with applicable land use regulations in effect at that time. A collection and recycling program will be executed to promote recycling of project components and minimize disposal in landfills. All permits related to decommissioning would be obtained, where required.

Project decommissioning may include the following activities:

- The facility would be disconnected from the utility power grid.
- Project components would be dismantled and removed using conventional construction equipment and recycled or disposed of safely.
- PV panel support steel and support posts would be removed and recycled off-site by an approved metals recycler.
- All compacted surfaces within the project site and temporary on-site haul roads would be de-compacted.

- Electrical and electronic devices, including inverters, transformers, panels, support structures, lighting fixtures, and their protective shelters would be recycled off-site by an approved recycler.
- All concrete used for the underground distribution system would be recycled off-site by a concrete recycler or crushed on-site and used as fill material.
- Fencing would be removed and recycled off-site by an approved metals recycler.
- Gravel roads would be removed; filter fabric would be bundled and disposed of in accordance with all applicable regulations. Road areas would be backfilled and restored to their natural contour.
- Soil erosion and sedimentation control measures would be re-implemented during the decommissioning period and until the site is stabilized.

2.7 Required Project Approvals

2.7.1 Imperial County

The following are the primary discretionary approvals required for implementation of the project:

1. **Approval of CUP.** Implementation of the project would require the approval of a CUP by the County to allow for the construction and operation of the proposed solar energy facility with an integrated BESS. The project site is located on two privately-owned legal parcels zoned Heavy Agriculture with a Renewable Energy Zone Overlay (A-3-RE). Pursuant to Title 9, Division 5, Chapter 9, the following uses are permitted in the A-3 zone subject to approval of a CUP from Imperial County:
 - i) *Battery Storage Facility (must be connected to an existing electrical power generation plant such as solar, geothermal, wind, natural gas, or other renewable energy generator, as an accessory unit to said power plant).*
 - oo) *Major facilities relating to the generation and transmission of electrical energy, provided such facilities are not under State or Federal law, to [be] approved exclusively by an agency, or agencies of the State or Federal government, and provided such facilities shall be approved subsequent to coordination review of the Imperial Irrigation District for electrical matters, meeting the requirements in Division 17.*
 - zz) *Solar energy plants meeting the requirements in Division 17.*
2. **Certification of the EIR.** After the required public review for the Draft EIR, the County will respond to written comments, edit the document, and produce a Final EIR to be certified by the Planning Commission and Board of Supervisors prior to deciding on approval or denial of the project.

Subsequent ministerial approvals may include, but are not limited to:

- Grading and clearing permits
- Building permits
- Reclamation plan
- Encroachment permits

- Transportation permit(s)

2.7.2 Discretionary Actions and Approvals by Other Agencies

Responsible Agencies are those agencies that have discretionary approval over one or more actions involved with development of the project. Trustee Agencies are state agencies that have discretionary approval or jurisdiction by law over natural resources affected by a project. These agencies may include, but are not limited to the following:

- California RWQCB – Notice of Intent for General Construction Permit, CWA 401 Water Quality Certification
- ICAPCD – Fugitive Dust Control Plan, Rule 801 Compliance
- CDFW (Trustee Agency) – ESA Compliance, Section 1600 Streambed Alteration Agreement
- USFWS – ESA Compliance
- USACE – Section 404 of the CWA Permit
- IID – Water Supply Agreement

2.7.3 Memorandum of Understanding – U.S. Border Patrol

The project applicant and U.S. Border Patrol (USBP) will develop and enter into a Memorandum of Understanding (MOU) setting forth the project-related activities that may occur on an existing dirt road used by the USBP.

- Project applicant will provide an additional 60 feet of right-of-way along its southern end of the property to allow for additional protective area for the U.S. Border Patrol Services functions.
- Project applicant will install a 6-foot-high chain link fence with barb wire on top surrounding the project site.
- Project applicant will provide a mechanism acceptable to USBP for access to the site upon completion of the construction in the event USBP needs to enter for enforcement purposes.
- Project applicant will provide full-time security during construction of the project and will coordinate with USBP on this service.
- Project applicant will provide contact information for both construction phases and operation phases to make sure USBP has direct contact information.
- Project applicant will maintain the road between the site and its terminus at the I-8/HWY 98 intersection during the construction of the site in a manner prescribed by USBP. At a minimum this will be routine watering and as necessary grading. No material will be added to the road without approval from USBP. Additionally, no work will be done adjacent to the road that would interfere with USBP's 'brushing' program.
- Project applicant will have an agreement with US BREC for the pedestrian traffic crossing at the IID drop and will observe USBP protocols for all people crossing for the project both during construction and future operations.
- Project applicant will notify the USBP's designated representative prior to any use of the road from Gordons Well access to the site.



- USBP will immediately contact designated project representatives if they encounter a problem at the site in an effort to give project applicant an opportunity to cure.

This page is intentionally blank.

3 Environmental Analysis, Impacts, and Mitigation

3.1 Introduction to Environmental Analysis

This section provides an overview of the environmental analysis and presents the format for the environmental analysis in each topical section.

3.1.1 Organization of Issue Areas

Chapter 3 provides an analysis of impacts for those environmental topics that the County determined could result in “significant impacts,” based on preparation of an Initial Study and review by the County’s Environmental Evaluation Committee and responses received during the scoping process, including the NOP review period and public scoping meeting. Sections 3.2 through 3.15 discuss the environmental impacts that may result with approval and implementation of the project, and where impacts are identified, recommends mitigation measures that, when implemented, would reduce significant impacts to a level less than significant. Each environmental issue area in Chapter 3 contains a description of the following:

- The environmental setting as it relates to the specific issue
- The regulatory framework governing that issue
- The threshold of significance (from Appendix G of the CEQA Guidelines)
- The methodology used in identifying and considering the issues
- An evaluation of the project-specific impacts and identification of mitigation measures
- A determination of the level of significance after mitigation measures are implemented
- The identification of any residual significant impacts following mitigation

3.1.2 Format of the Impact Analysis

This analysis presents the potential impacts that could occur under the project along with any supporting mitigation requirements. Each section identifies the resulting level of significance of the impact using the terminology described below following the application of the proposed mitigation. The section includes an explanation of how the mitigation measure(s) reduces the impact in relation to the applied threshold of significance. If the impact remains significant (i.e., at or above the threshold of significance), additional discussion is provided to disclose the implications of the residual impact and indicate why no mitigation is available or why the applied mitigation does not reduce the impact to a less than significant level.

Changes that would result from the project were evaluated relative to existing environmental conditions within the project site as defined in Chapter 2 and illustrated on Figure 2-2 (Chapter 2). Existing environmental conditions are based on the time at which the NOP was published on May 4, 2021. In evaluating the significance of these changes, this EIR applies thresholds of significance that have been developed using: (1) criteria discussed in the CEQA Guidelines; (2) criteria based on factual or

scientific information; and (3) criteria based on regulatory standards of local, state, and/or federal agencies. Mechanisms that could cause impacts are discussed for each issue area.

This EIR uses the following terminology to denote the significance of environmental impacts of the project:

- *No impact* indicates that the construction, operation, and maintenance of the project would not have any direct or indirect effects on the environment. It means no change from existing conditions. This impact level does not need mitigation.
- A *less than significant impact* is one that would not result in a substantial or potentially substantial adverse change in the physical environment. This impact level does not require mitigation, even if feasible, under CEQA.
- A *significant impact* is defined by CEQA Section 21068 as one that would cause “a substantial, or potentially substantial, adverse change in any of the physical conditions within the area affected by the project.” Levels of significance can vary by project, based on the change in the existing physical condition. Under CEQA, mitigation measures or alternatives to the project must be provided, where feasible, to reduce the magnitude of significant impacts.
- An *unmitigable significant impact* is one that would result in a substantial or potentially substantial adverse effect on the environment, and that could not be reduced to a less than significant level even with any feasible mitigation. Under CEQA, a project with significant and unmitigable impacts could proceed, but the lead agency would be required to prepare a “statement of overriding considerations” in accordance with State CEQA Guidelines California Code of Regulations (CCR) Section 15093, explaining why the lead agency would proceed with the project in spite of the potential for significant impacts.

3.2 Aesthetics and Visual Resources

This section provides a description of the existing visual and aesthetic resources within the project area and relevant state and local plans and policies regarding the protection of scenic resources. Effects to the existing visual character of the project area as a result of project-related facilities are considered and mitigation is proposed based on the anticipated level of significance. The information provided in this section is summarized from the *Visual Impact Assessment Letter Report – VEGA SES 4 Project* (Appendix B of this EIR) prepared by ECORP Consulting, Inc.

3.2.1 Existing Conditions

The project site is located in south-central Imperial County. The irregular shaped project site is bound by undeveloped land, portions of which have been disturbed associated with previous agricultural-related activities to the west and east, the All-American Canal running southwest on the northern border of the project site, and the U.S./Mexico international border to the south. The topography of the project site is relatively flat with elevations ranging between 38 feet and 60 feet) above mean sea level. The majority of the project site consists of creosote bush scrub, alkali weed, and disturbed land.

Scenic Vista

Scenic vistas are typically expansive views from elevated areas. They may or may not be part of a designated scenic overlook or other area providing a static vista view of a landscape. The project site is located in a rural portion of Imperial County and is not located within an area containing a scenic vista designated by the State or the County's General Plan.

Scenic Highways

According to the Conservation and Open Space Element, no State scenic highways have been designated in Imperial County (County of Imperial 2016). The project site is not located within a State scenic highway corridor, nor are there any State scenic highways located in proximity to the project site. The nearest road segment considered eligible for a State scenic highway designation is Interstate 8, located over five miles northwest of the project site.

Visual Character

Available public right of way in the vicinity of the project site includes SR-98 and Vencil Road. Visibility of the project site from the public right of way is obstructed from SR-98 by a berm. Visibility of the project site from Vencil Road is limited due to a distance of approximately 0.5 mile. Surrounding property is privately owned and viewers would be limited to property owners, employees servicing/maintaining IID facilities (e.g., the canal), and border patrol personnel.

Light, Glare, and Glint

Glare is considered a continuous source of brightness, relative to diffused light, whereas glint is a direct redirection of the sun beam in the surface of a PV solar module. Glint is highly directional, since its origin is purely reflective, whereas glare is the reflection of diffuse irradiance; it is not a direct reflection of the sun.

The project site is currently vacant and due to its rural location does not generate any light or glare under existing conditions.

3.2.2 Regulatory Setting

This section identifies and summarizes laws, policies, and regulations that are applicable to the project.

State

California Department of Transportation

Caltrans manages the California Scenic Highway Program. The goal of the program is to preserve and protect scenic highway corridors from changes that would affect the aesthetic value of the land adjacent to the scenic corridor.

Local

Imperial County General Plan

The Imperial County General Plan contains policies for the protection and conservation of scenic resources and open spaces within the County. These policies also provide guidance for the design of new development. The Conservation and Open Space Element of the General Plan provides specific goals and objectives for maintaining and protecting the aesthetic character of the region. Table 3.2-1 provides an analysis of the project’s consistency with the Conservation and Open Space Element Goal 5. Additionally, the Circulation and Scenic Highways Element of the General Plan provides policies for protecting and enhancing scenic resources within highway corridors in Imperial County, consistent with the Caltrans State Scenic Highway Program.

County of Imperial Land Use Ordinance, Title 9

The County’s Land Use Ordinance Code provides specific direction for lighting requirements.

Division 17: Renewable Energy Resources, Section 91702.00 – Specific Standards for All Renewable Energy Projects

- (R) Lights should be directed or shielded to confine direct rays to the Project site and muted to the maximum extent consistent with safety and operational necessity.

Table 3.2-1. Consistency with Applicable General Plan Conservation and Open Space Policies

General Plan Policies	Consistency with General Plan	Analysis
Goal 5: The aesthetic character of the region shall be protected and enhanced to provide a pleasing environment for residential, commercial, recreational, and tourist activity.	Consistent	As described in Section 3.2.3, the proposed project would result in changes to the existing visual character of the project site. However, public views of the project site are limited, and the proposed project would not result in a significant deterioration in the visual character of the project site or surrounding area from public viewpoints.

Table 3.2-1. Consistency with Applicable General Plan Conservation and Open Space Policies

General Plan Policies	Consistency with General Plan	Analysis
Objective 5.1: Encourage the conservation and enhancement of the natural beauty of the desert and mountain landscape.	Consistent	The project site is located on rural agricultural land located in Imperial County. The irregular shaped project site is bound by undeveloped land, portions of which have been disturbed associated with previous agricultural-related activities to the west and east, the All-American Canal running southwest on the northern border of the project site, and the U.S./Mexico international border to the south. The project site is currently characterized by flat and undeveloped land, portions of which have been disturbed associated with previous agricultural-related activities. Development of the project site would not impact the desert and mountain landscapes common in Imperial County.

Source: County of Imperial 2016

3.2.3 Impacts and Mitigation Measures

Thresholds of Significance

Based on CEQA Guidelines Appendix G, project impacts related to aesthetics are considered significant if any of the following occur:

- Have a substantial adverse effect on a scenic vista
- Substantially damage scenic resources, including, but not limited to, trees, rock outcroppings, and historic buildings within a state scenic highway
- In non-urbanized areas, substantially degrade the existing visual character or quality of public views of the site and its surroundings? (Public views are those that are experienced from publicly accessible vantage points). If the project is in an urbanized area, would the project conflict with applicable zoning and other regulations governing scenic quality
- Create a new source of substantial light or glare which would adversely affect day or nighttime views in the area

Methodology

Due to the rural nature of the project site, the evaluation of potential visual impacts resulting from implementation of the proposed project was based on the following qualitative criteria:

- **Changes in Visual Quality.** The difference in visual quality between the existing environmental setting and post-project condition is considered visual quality change. Changes in visual quality were identified by studying engineering plans, which provide information on the various elements that would be added to the current viewshed and the degree of change in the existing visual setting.

- **Impacts to Visual Resources.** Visual resources from both the natural and built environments can enhance the visual character and aesthetic quality of an area. Visual resources can be associated with local events and history that represent and enhance the visual character of the local area. The project site and vicinity were studied for visual resources. A project that substantially alters important visual resources can result in adverse visual impacts. Mitigation is typically implemented to remove or minimize adverse visual impacts.
- **Light, Glare, Shade, and Shadow.** The existing light environment serves as a baseline to conduct light analysis and compare potential impacts caused by introduction of one of the alternatives. Impacts relating to light, glare, shade, and shadow were examined during field observations and photographs to help establish light conditions during various times of the day and night and to estimate the potential changes in the environment from project implementation. Impacts were evaluated based on how much the existing conditions change, the degree of those changes, and the sensitivity of the affected environment.
- **Compatibility with Visual Policies.** General plans, specific plans, and other regulations or policies relating to visual resources and setting at the project site were identified and reviewed, to assess the project's compatibility with applicable policies.

Impact Analysis

Impact 3.2-1 Would the project have a substantial adverse effect on a scenic vista?

There are no designated scenic vistas in the project vicinity. The proposed project would involve the use of standard construction equipment including, but limited to, trucks, cranes, and tractors. The presence of this equipment within the project area during construction would alter views of the area from undeveloped land to a construction site. However, the views of construction activity from the surrounding vicinity would be temporary and would not involve any designated scenic vistas. Therefore, impacts to a scenic vista are considered less than significant during construction.

Upon project operation, and with implementation of the solar infrastructure, the overall visual character of the project site would change. However, given that there are no scenic resources or vistas within proximity to the project site, project operation would not have a substantial adverse effect on a scenic vista. Impacts are considered less than significant.

Mitigation Measure(s)

No mitigation measures are required.

Impact 3.2-2 Would the project substantially damage scenic resources, including, but not limited to, trees, rock outcroppings, and historic buildings within a state scenic highway?

According to the Conservation and Open Space Element, no State scenic highways have been designated in Imperial County (County of Imperial 2016). The project site is not located within a State scenic highway corridor, nor are there any State scenic highways located in proximity to the project site. The nearest road segment considered eligible for a State scenic highway designation is Interstate 8, located over five miles northwest of the project site. Therefore, no impacts to scenic resources within a designated state scenic highway would occur.

Mitigation Measure(s)

No mitigation measures are required.

Impact 3.2-3 In non-urbanized areas, would the project substantially degrade the existing visual character or quality of public views of the site and its surroundings? (Public views are those that are experienced from publicly accessible vantage points). If the project is in an urbanized area, would the project conflict with applicable zoning and other regulations governing scenic quality?

The project site is located on a vacant site in rural Imperial County. Visibility of the project site from the public right of way is obstructed from SR-98 by a berm. Visibility of the project site from Vencil Road is limited due to a distance of approximately 0.5 mile. Surrounding property is privately owned and viewers would be limited to private property owners, employees servicing/maintaining IID facilities (e.g., the canal), and border patrol personnel.

Specifically, and as stated above in Impact 3.2-1, construction of the project would result in temporary visual changes due to the presence of construction equipment, materials, and construction activities. However, visual impacts during project construction would be short-term. Upon completion of construction, equipment and construction materials would no longer be present on-site. Therefore, project construction would not substantially degrade the existing visual character or quality of public views of the site and its surroundings.

Project operation would change the visual character of the project site by altering the natural conditions of the site to a solar energy generation and battery storage facility. The main physical change that would occur is the complete removal of vegetation and grading of the project site to accommodate the construction of solar apparatus and security fencing. While the proposed PV module frames would be approximately 7.5 feet in height and the proposed security fencing would be approximately 6 feet in height, views of the project site are limited from public viewpoints, and, as such, the addition of solar infrastructure to the project site would not substantially degrade the existing visual character or quality of public views of the site and its surroundings. Other facilities proposed such as roads, pads, underground utilities, and stormwater facilities would not be readily visible from public viewpoints as these facilities would be at or below grade.

Based on the above evaluation, the project would not substantially degrade the existing visual character or quality of public views of the site and its surroundings or conflict with applicable zoning. Impacts are considered less than significant.

Mitigation Measure(s)

No mitigation measures are required.

Impact 3.2-4 Would the project create a new source of substantial light or glare which would adversely affect day or nighttime views in the area?

As described in Chapter 2, Project Description, the project would include new sources of nighttime lighting. In addition, given the nature of the project (e.g., solar facility), this discussion also considers potential glare- and glint-related impacts generated by the proposed solar arrays. This discussion considers each issue under the associated headings below.

NIGHTTIME LIGHTING

Project construction may result in slight increases in nighttime lighting onsite if nighttime construction is warranted. However, public views of the project site are limited and, as such, construction-related nighttime lighting is not anticipated to adversely affect nighttime views. Additionally, visual impacts associated with nighttime lighting during project construction would be short-term. Upon completion of construction, equipment and construction materials would no longer be present on-site. Therefore, this is considered a less than significant impact.

Minimal lighting would be required for project operation and would be limited to safety and security functions. All lighting would be directed downward and shielded to confine direct rays to the project site and muted to the maximum extent consistent with safety and operational necessity (Title 9, Division 17, Chapter 2: Specific Standards for all Renewable Energy Projects, of the County's Zoning Ordinance).

If additional lighting should be required for nighttime maintenance, portable lighting equipment would be used. Based on these considerations, and the distance to potential viewers, the project is not anticipated to create a new source of substantial light which would adversely affect nighttime views in the project area, and the impact is considered less than significant.

GLARE AND GLINT

Project construction may result in slight increases in glare and glint onsite due to the presence of reflective construction equipment and materials. However, public views of the project site are limited and, as such, construction-related glare and glint are not anticipated to adversely affect day or nighttime views. Additionally, visual impacts associated with light and glare during project construction would be short-term. Upon completion of construction, equipment and construction materials would no longer be present on-site. Therefore, this is considered a less than significant impact.

The project would involve the installation of PV solar arrays which have low reflectivity. Solar PV modules are specifically designed to reduce reflection as any reflected light cannot be converted into energy. Research has shown that reflectivity from PV panels is similar to reflections from water (Appendix B of this EIR). Therefore, upon operation, the PV panels would not create a significant source of glare during sunlight hours. Additionally, public views of the project site are limited and, as such, operation-related glare and glint, while minimal, are not anticipated to adversely affect day or nighttime views. The project would not use other reflective materials such as fiberglass, aluminum or vinyl/plastic siding, galvanized products, and brightly painted steel roofs that have the potential to create on- and off-site glare.

Shade and shadow effects would be introduced within the project site due to the placement of PV modules in arrays. However, due to the height of the proposed apparatus at 7.5 feet and the perimeter fencing at 6 feet, the effects of shade and shadow would not encroach into areas offsite for extended periods of time that would result in significant shade and/or shadow impacts. Therefore, the proposed project would not result in a significant glare impact to motorists driving on roadways adjacent to the project site.

Mitigation Measure(s)

No mitigation measures are required.

3.2.4 Decommissioning/Restoration and Residual Impacts

Decommissioning/Restoration

If at the end of the PPA term, no contract extension is available for a power purchaser, no other buyer of the energy emerges, or there is no further funding of the project, the project will be decommissioned and dismantled. The project site is relatively flat and primarily characterized by a level elevation. Therefore, no grading or significant landform modifications would be required during decommissioning activities upon site restoration in the future. Although the project site would be visually disrupted in the short-term during decommissioning activities, because extensive grading is not required and these activities would be temporary, the visual character of the project site would not be substantially degraded in the short-term and related impacts would be less than significant.

Residual

Impacts related to glare and glint impacts to roadway travelers would be less than significant and no additional mitigation measures are required. Changes to visual character of the project area would be less than significant and would be transitioned back to their prior (pre-solar project) conditions following site decommissioning. Based on these conclusions, implementation of the project would not result in residual significant unmitigable impacts to the visual character of the project area or add substantial amounts of light and glare.

This page is intentionally blank.



3.3 Agricultural Resources

This section provides an overview of existing agricultural resources within the project site and identifies applicable federal, state, and local policies related to the conservation of agricultural lands. This includes a summary of the production outputs, soil resources, and adjacent operations potentially affected by the project. The impact assessment in Section 3.3.3 provides an evaluation of potential adverse effects on agricultural resources based on criteria derived from the CEQA Guidelines in conjunction with actions proposed in Chapter 2, Project Description. Section 3.3.4 provides a discussion of residual impacts, if any.

No forestry resources are present within the project site and, therefore, this section focuses on issues related to agricultural resources.

3.3.1 Existing Conditions

Agriculture has been the single most important economic activity of Imperial County throughout the 20th century and is expected to play a major economic role in the foreseeable future. The gross annual value of agricultural production in the County has hovered around \$1 billion for the last several years, making it the County's largest source of income and employment.

Imperial County agriculture is a major producer and supplier of high-quality plant and animal foods and non-food products. In 2019, agriculture contributed a total of \$2.01 billion to the county economy. Vegetable and melon crops were the single largest production category by dollar value (\$799 million). Livestock represented the second largest category (\$522 million) and consisted mostly of feedlot cattle (\$449 million). Field crops ranked third with \$498 million (Imperial County Agricultural Commissioner 2019).

Important Farmland

According to the California Department of Conservation's (DOC) California Important Farmland Finder, the majority of the project site is designated as Other Land (DOC 2021). A portion of the project site is designated as Farmland of Local Importance. Farmland of Local Importance is not considered an "agricultural land" per CEQA Statute Section 21060.1(a). The project site does not contain Prime Farmland, Farmland of Statewide Importance, or Unique Farmland. No portion of the project site is currently being utilized for agricultural production and has remained in a fallow state for a period of time (exceeding five years).

Williamson Act Contract Land

According to the 2016/2017 Imperial County Williamson Act Map produced by the DOC, the project site is not located on Williamson Act contracted land (DOC 2016).

3.3.2 Regulatory Setting

This section identifies and summarizes state and local laws, policies, and regulations that are applicable to the project.

State

California Land Conservation Act

The Williamson Act (California Land Conservation Act, California Government Code, Section 51200 et seq.) is a statewide mechanism for the preservation of agricultural land and open space land. The Act provides a comprehensive method for local governments to protect farmland and open space by allowing land in agricultural use to be placed under contract (agricultural preserve) between a local government and a landowner.

Under the provisions of the Williamson Act (California Land Conservation Act 1965, Section 51200), landowners contract with the County to maintain agricultural or open space use of their lands in return for reduced property tax assessment. The contract is self-renewing and the landowner may notify the County at any time of intent to withdraw the land from its preserve status. Withdrawal involves a 10-year period of tax adjustment to full market value before protected open space can be converted to urban uses. Consequently, land under a Williamson Act Contract can be in either a renewal status or a nonrenewable status. Lands with a nonrenewable status indicate the farmer has withdrawn from the Williamson Act Contract and is waiting for a period of tax adjustment for the land to reach its full market value. Nonrenewable and cancellation lands are candidates for potential urbanization within a period of 10 years.

The requirements necessary for cancellation of land conservation contracts are outlined in Government Code Section 51282. The County must document the justification for the cancellation through a set of findings. Unless the land is covered by a farmland security zone contract, the Williamson Act requires that local agencies make both the Consistency with the Williamson Act and Public Interest findings.

On February 23, 2010, the Imperial County Board of Supervisors voted to not accept any new Williamson Act contracts and not to renew existing contracts because of the elimination of the subvention funding from the state budget. The County reaffirmed this decision in a vote on October 12, 2010, and notices of nonrenewal were sent to landowners with Williamson Act contracts following that vote. The applicable deadlines for challenging the County's actions have expired, and, therefore, all Williamson Act contracts in Imperial County will terminate on or before December 31, 2018.

California Farmland Mapping and Monitoring Program

The California DOC, under the Division of Land Resource Protection, has set up the Farmland Mapping and Monitoring Program (FMMP), which monitors the conversion of the state's farmland to and from agricultural use. The map series identifies eight classifications, as defined below, and uses a minimum mapping unit size of 10 acres.

- Prime Farmland has the best combination of physical and chemical features able to sustain long-term agricultural production. This land has the soil quality, growing season, and moisture supply needed to produce sustained high yields. Land must have been used for irrigated agricultural production at some time during the 4 years prior to the mapping date.
- Farmland of Statewide Importance is similar to Prime Farmland but with minor shortcomings, such as greater slopes or less ability to store soil moisture. Land must have been used for irrigated agricultural production at some time during the 4 years prior to the mapping date.

- Unique Farmland consists of lesser quality soils used for the production of the state's leading agricultural crops. This land is usually irrigated but may include non-irrigated orchards or vineyards as found in some climatic zones in California. Land must have been cropped at some time during the 4 years prior to the mapping date.
- Farmland of Local Importance is land of importance to the local agricultural economy as determined by each county's board of supervisors and a local advisory committee.
- Grazing Land is land on which the existing vegetation is suited to the grazing of livestock. This category was developed in cooperation with the California Cattlemen's Association, University of California Cooperative Extension, and other groups interested in the extent of grazing activities.
- Urban and Built-up Land is occupied by structures with a building density of at least one unit to 1.5 acre, or approximately six structures to a 10-acre parcel. Common examples include residential, industrial, commercial, institutional facilities, prisons, cemeteries, airports, golf courses, sanitary landfills, sewage treatment, and water control structures.
- Water is defined as perennial water bodies with an extent of at least 40 acres.
- Other Land is land not included in any other mapping category. Common examples include low density rural developments, vegetative and riparian areas not suitable for livestock grazing, confined animal agriculture facilities, strip mines, borrow pits, and water bodies smaller than 40 acres. Vacant and nonagricultural land surrounded on all sides by urban development and greater than 40 acres is mapped as Other Land. More detailed data on these uses is available in counties containing the Rural Land Use Mapping categories.

The program also produces a biannual report on the amount of land converted from agricultural to non-agricultural use. The program maintains an inventory of state agricultural land and updates its "Important Farmland Series Maps" every 2 years. Table 3.3-1 provides a summary of agricultural land within Imperial County converted to non-agricultural uses during the time frame from 2016 to 2018.

Table 3.3-1. Imperial County Change in Agricultural Land Use Summary (2016 to 2018)

Land Use Category	Total Acreage Inventoried		2016 to 2018 Acreage Changes			
	2016	2018	Acres Lost (-)	Gained (+)	Total Acreage Changed	Net Acreage Changed
Prime Farmland	190,206	189,163	1,699	656	2,355	-1,043
Farmland of Statewide Importance	297,272	291,596	6,330	654	6,984	-5,676
Unique Farmland	2,071	1,905	190	24	214	-166
Farmland of Local Importance	38,923	39,711	1,587	2,375	3,962	788
Important Farmland Subtotal	528,472	522,375	9,806	3,709	13,515	-6,097
Grazing Land	0	0	0	0	0	0

Table 3.3-1. Imperial County Change in Agricultural Land Use Summary (2016 to 2018)

Land Use Category	Total Acreage Inventoried		2016 to 2018 Acreage Changes			
	2016	2018	Acres Lost (-)	Gained (+)	Total Acreage Changed	Net Acreage Changed
Agricultural Land Subtotal	528,472	522,375	9,806	3,709	13,515	-6,097
Urban and Built-Up Land	37,412	41,764	301	4,653	4,954	4,352
Other Land	461,891	463,488	712	2,309	3,021	1,597
Water Area	749	897	125	273	398	148
Total Area Inventoried	1,028,524	1,028,524	10,944	10,944	21,888	0

Source: DOC 2018

Local

County of Imperial General Plan

The Agricultural Element of the County’s General Plan serves as the primary policy statement for implementing development policies for agricultural land use in Imperial County. The goals, objectives, implementation programs, and policies found in the Agricultural Element provide direction for new development as well as government actions and programs. Imperial County’s Goals and Objectives are intended to serve as long-term principles and policy statements to guide agricultural use decision-making and uphold the community’s ideals.

Agriculture has been the single most important economic activity in the County throughout its history. The County recognizes the area as one of the finest agricultural areas in the world because of several environmental and cultural factors including good soils, a year-round growing season, the availability of adequate water transported from the Colorado River, extensive areas committed to agricultural production, a gently sloping topography, and a climate that is well-suited for growing crops and raising livestock. The Agricultural Element in the County General Plan demonstrates the long-term commitment by the County to the full promotion, management, use, and development and protection of agricultural production, while allowing logical, organized growth of urban areas (County of Imperial 2015).

The County’s Agricultural Element identifies several Implementation Programs and Policies for the preservation of agricultural resources. The Agricultural Element recognizes that the County can and should take additional steps to provide further protection for agricultural operations and at the same time provide for logical, organized growth of urban areas. The County must be specific and consistent about which lands will be maintained for the production of food and fiber and for support of the County’s economic base. The County’s strategy and overall framework for maintaining agriculture includes the following policy directed at the preservation of Important Farmland:

The overall economy of the County is expected to be dependent upon the agricultural industry for the foreseeable future. As such, all agricultural land in the County is considered as Important Farmland, as defined by federal and state agencies, and should be reserved for agricultural uses. Agricultural land may be converted to non-agricultural uses only where a clear and immediate need can be demonstrated, such as requirements for urban housing, commercial facilities, or employment opportunities. All existing agricultural land will be preserved for irrigation agriculture, livestock production, aquaculture, and other agriculture-related uses except for non-agricultural uses identified in this General Plan or in previously adopted City General Plans.

The following program is provided in the Agricultural Element:

No agricultural land designated except as provided in Exhibit C [of the Agricultural Element] shall be removed from the Agriculture category except where needed for use by a public agency, for geothermal purposes, where a mapping error may have occurred, or where a clear long-term economic benefit to the County can be demonstrated through the planning and environmental review process. The Board (or Planning Commission) shall be required to prepare and make specific findings and circulate same for 60 days (30 days for parcels considered under Exhibit C of this [Agricultural] element) before granting final approval of any proposal, which removes land from the Agriculture category.

Also, the following policy addresses Development Patterns and Locations on Agricultural Land:

“Leapfrogging” or “checkerboard” patterns of development have intensified recently and result in significant impacts on the efficient and economic production of adjacent agricultural land. It is a policy of the County that leapfrogging will not be allowed in the future. All new non-agricultural development will be confined to areas identified in this plan for such purposes or in Cities’ adopted Spheres of Influence, where new development must adjoin existing urban uses. Non-agricultural residential, commercial, or industrial uses will only be permitted if they adjoin at least one side of an existing urban use, and only if they do not significantly impact the ability to economically and conveniently farm adjacent agricultural land.

Agricultural Element Programs that address “leapfrogging” or “checkerboard” development include:

All non-agricultural uses in any land use category shall be analyzed during the subdivision, zoning, and environmental impact review process for their potential impact on the movement of agricultural equipment and products on roads located in the Agriculture category, and for other existing agricultural conditions which might impact the projects, such as noise, dust, or odors.

The Planning and Development Services Department shall review all proposed development projects to assure that any new residential or non-agricultural commercial uses located on agriculturally zoned land, except land designated as a Specific Plan Area, be adjoined on at least one entire property line to an area of existing urban uses. Developments that do not meet these criteria should not be approved.

Table 3.3-2 provides a General Plan goal and policy consistency evaluation for the project.

Table 3.3-2. Project Consistency with Applicable General Plan Agricultural Policies

General Plan Policies	Consistency with General Plan	Analysis
<p>Goal 1. All Important Farmland, including the categories of Prime Farmland, Farmland of Statewide Importance, Unique Farmland, and Farmland of Local Importance, as defined by federal and state agencies, should be reserved for agricultural uses.</p>	<p>Consistent</p>	<p>The project site does not contain Prime Farmland or Farmland of Statewide Importance. Therefore, the proposed project would not convert land designated as Prime Farmland or Farmland of Statewide Importance to non-agricultural uses. A portion of the project site is designated as Farmland of Local Importance. The project site is not currently utilized for agricultural production and has remained fallow for a period of time (exceeding five years). The proposed project would temporarily convert Farmland of Local Importance to non-agricultural uses. However, as part of the project, the project applicant or its successor in interest will be responsible for implementing a reclamation plan when the project is decommissioned at the end of its lifespan. The reclamation plan includes the removal, recycling, and/or disposal of all solar arrays, inverters, transformers, and other structures on the project site, as well as restoration of the site to its pre-project condition. Therefore, the proposed project would not permanently convert Farmland of Local Importance to non-agricultural uses.</p>
<p>Objective 1.5. Direct development to less valuable farmland (i.e., Unique Farmland and Farmland of Local Importance rather than Prime Farmland or Farmland of Statewide Importance) when conversion of agricultural land is justified.</p>	<p>Consistent</p>	<p>The project site is located within the County's designated Renewable Energy zone and is, therefore, considered to be located within an area that has been determined to be appropriate for the development of solar facilities. The majority of the project site is designated as Other Land. A portion of the project site is designated as Farmland of Local Importance. A reclamation plan would be prepared for the project site, which, when implemented, would return the site to existing conditions after the solar use is discontinued.</p>
<p>Objective 1.6. Recognize and preserve unincorporated areas of the County, outside of city sphere of influence areas, for irrigation agriculture, livestock production, aquaculture, and other special uses.</p>	<p>Consistent.</p>	<p>The project site is located within the County's designated Renewable Energy Zone and is, therefore, considered to be located within an area that has been determined to be appropriate for the development of solar facilities. The project would temporarily convert land located in an unincorporated area to non-agricultural uses; however, with the approval of a CUP, the project would be considered an allowable use in an agricultural zone as a conditionally-allowed use.</p>
<p>Objective 1.8. Allow conversion of agricultural land to non-agricultural uses including renewable energy only where a clear and immediate need can be demonstrated, based on economic benefits, population projections and lack of other available land (including land within</p>	<p>Consistent</p>	<p>The project site is located within the County's designated Renewable Energy Zone and is, therefore, consistent with the General Plan. Additionally, with the approval of a CUP, the project would be consistent with the County's Land Use Ordinance. Therefore, the project is consistent with the County's General Plan land</p>



Table 3.3-2. Project Consistency with Applicable General Plan Agricultural Policies

General Plan Policies	Consistency with General Plan	Analysis
incorporated cities) for such non-agricultural uses. Such conversion shall also be allowed only where such uses have been identified for non-agricultural use in a city general plan or the County General Plan and are supported by a study to show a lack of alternative sites.		use designation.
Objective 1.11. Control and prevent soil erosion when possible.	Consistent	The project would implement BMPs within the site during construction and long-term operation of the project.
Goal 2. Adopt policies that prohibit “leapfrogging” or “checkerboard” patterns of nonagricultural development in agricultural areas and confine future urbanization to adopted Sphere of Influence area.	Consistent	The project is located within the County’s designated Renewable Energy Zone, which identifies areas that are considered appropriate for the development of renewable energy. The project does not include a residential component that would induce urbanization adjacent to the project. Furthermore, with the approval of a CUP, the project would be consistent with the County’s Land Use Ordinance. Consistency with the Land Use Ordinance implies consistency with the General Plan land use designation.
Objective 2.1. Do not allow the placement of new non-agricultural land uses such that agricultural fields or parcels become isolated or more difficult to economically and conveniently farm.	Consistent	The project is located within the County’s designated Renewable Energy Zone, which identifies areas that are considered appropriate for the development of renewable energy. Neither construction nor operation of the solar facility would not make it difficult to economically or conveniently farm.
Objective 2.2. Encourage the infilling of development in urban areas as an alternative to expanding urban boundaries.	Consistent	The project is located within the County’s designated Renewable Energy Zone, which identifies areas that are considered appropriate for the development of renewable energy. The project consists of the construction and operation of a solar facility. While the project would introduce development in the area, it would not include residential uses that would, in turn, create a demand for other uses, such as commercial, employments centers, and supporting services.
Objective 2.3. Maintain agricultural lands in parcel size configurations that help assure that viable farming units are retained.	Consistent	The project does not involve the subdivision of the property into smaller parcels. The project is considered a temporary industrial use but would not induce growth in the area nor result in the expansion of urban boundaries. While the project would temporarily convert agricultural land to non-agricultural uses; a reclamation plan would be prepared for the project site, which, when implemented, would return the site to its pre-project conditions after the solar uses are discontinued.

Table 3.3-2. Project Consistency with Applicable General Plan Agricultural Policies

General Plan Policies	Consistency with General Plan	Analysis
Objective 2.4. Discourage the parcelization of large holdings.	Consistent	The project does not involve the subdivision of the property into smaller parcels. The size of the existing parcels would be retained for future agricultural use following site restoration.
Objective 2.6. Discourage the development of new residential or other non-agricultural areas outside of city “sphere of influence” unless designated for non-agricultural use in the County General Plan, or for necessary public facilities.	Consistent	The project is located within the County’s designated Renewable Energy Zone, which identifies areas that are considered appropriate for the development of renewable energy.
Goal 3. Limit the introduction of conflicting uses into farming areas, including residential development of existing parcels which may create the potential for conflict with continued agricultural use of adjacent property.	Consistent	Upon approval of a CUP, the proposed project would be an allowable use within the applicable agricultural zone. Additionally, the project does not include the development of housing. The solar development would be compatible with existing agricultural uses to the west.
Objective 3.2. Enforce the provisions of the Imperial County Right-to-Farm Ordinance (No. 1031).	Consistent	The Imperial County Right-to-Farm Ordinance would be enforced. Existing nuisance issues, such as noise, dust, and odors from existing agricultural use would not impact the project given the general lack of associated sensitive uses (e.g., residences). Likewise, with mitigation measures proposed in other resource sections (e.g., air quality, noise, etc.) project-related activities would not adversely affect adjacent agricultural operations.
Objective 3.3. Enforce the provisions of the State nuisance law (California Code Sub-Section 3482).	Consistent	The provisions of the state nuisance law would be incorporated into the project. As discussed below, there is the potential that weeds or other pests may occur within the solar field if these areas are not properly maintained and managed to control weeds and pests. Mitigation Measure AG-1 requires the project applicant to develop a Pest Management Plan prior to the issuance of a grading permit or building permit (whichever occurs first).

Source: County of Imperial 2015

BMP – best management practice; CUP – conditional use permit; IID – Imperial Irrigation District

3.3.3 Impacts and Mitigation Measures

This section presents the significance criteria used for considering project impacts related to agricultural resources, the methodology employed for the evaluation, an impact evaluation, and mitigation requirements, if necessary.



Thresholds of Significance

Based on CEQA Guidelines Appendix G, project impacts related to agricultural resources are considered significant if any of the following occur:

- Convert Prime Farmland, Unique Farmland, or Farmland of Statewide Importance (Farmland) as shown on the maps prepared pursuant to the FMMP of the California Resources Agency, to non-agricultural use
- Conflict with existing zoning for agricultural use, or a Williamson Act contract
- Involve other changes in the existing environment which, due to their location or nature, could result in conversion of Farmland, to non-agricultural use

Methodology

This analysis evaluates the potential for the project, as described in Chapter 2, Project Description, to adversely impact agricultural resources within the project site based on the applied significance criteria as identified above. The analysis prepared for this EIR relied on Important Farmland and Williamson Act maps for Imperial County produced by the California DOC's Division of Land Resource Protection. These sources were used to determine the agricultural significance of the land in the project site. Per the County of Imperial General Plan, Farmland of Local Importance is also considered an important farmland.

Additionally, potential conflicts with existing agricultural zoning or other changes resulting from the implementation of the project, which could indirectly remove Important Farmland from agricultural production or reduce agricultural productivity were considered. Sources used in this evaluation included, but were not limited to, the Imperial County General Plan and zoning ordinance. The conceptual site plan for the project (Chapter 2, Figure 2-3) was also used to evaluate potential impacts.

Impact Analysis

Impact 3.3-1 Would the project convert Prime Farmland, Unique Farmland, or Farmland of Statewide Importance (Farmland) as shown on the maps prepared pursuant to the FMMP of the California Resources Agency, to non-agricultural use?

The project site does not contain Prime Farmland, Farmland of Statewide Importance, or Unique Farmland. Therefore, the proposed project would not convert land designated as Prime Farmland, Farmland of Statewide Importance, or Unique Farmland to non-agricultural uses.

According to the California DOC's California Important Farmland Finder, the majority of the project site is designated as Other Land (DOC 2021). A portion of the project site is designated as Farmland of Local Importance. It should be noted that analysis of Other Land and Farmland of Local Importance is not required under CEQA significance criteria, as these designations are not considered an "agricultural land" per CEQA Statute Section 21060.1(a). The proposed project would temporarily convert Farmland of Local Importance to non-agricultural uses. However, as a condition of project approval (CUP condition), the project applicant or its successor in interest will be responsible for implementing a reclamation plan when the project is decommissioned at the end of its lifespan. The reclamation plan includes the removal, recycling, and/or disposal of all solar arrays, inverters, transformers, and other structures on the project site, as well as restoration of the site to its pre-project condition. The County is responsible for approving the reclamation plan for the project

and confirming that financial assurances for the project are in conformance with Imperial County ordinances prior to the issuance of any building permits. This shall be made a condition of approval and included in the CUP. Implementation of the reclamation plan would reduce the impact associated with the temporary conversion of Farmland of Local Importance to non-agricultural uses to a level less than significant.

Mitigation Measure(s)

No mitigation measures are required.

Impact 3.3-2 Would the project conflict with existing zoning for agricultural use, or a Williamson Act contract?

Williamson Act. The project site is not located on Williamson Act contracted land (DOC 2016). Therefore, the project would not conflict with a Williamson Act contract and no impact would occur.

Agricultural Zoning. Pursuant to the County General Plan, the project site is located on land designated for agricultural uses. The project would be constructed on land currently zoned A-3-RE (Heavy Agriculture with a Renewable Energy Zone Overlay). Pursuant to Title 9, Division 5, Chapter 9, the following uses are permitted in the A-3 zone subject to approval of a CUP from Imperial County:

i) Battery Storage Facility (must be connected to an existing electrical power generation plant such as solar, geothermal, wind, natural gas, or other renewable energy generator, as an accessory unit to said power plant).

oo) Major facilities relating to the generation and transmission of electrical energy, provided such facilities are not under State or Federal law, to [be] approved exclusively by an agency, or agencies of the State or Federal government, and provided such facilities shall be approved subsequent to coordination review of the Imperial Irrigation District for electrical matters, meeting the requirements in Division 17.

zz) Solar energy plants meeting the requirements in Division 17.

Upon approval of a CUP, the project's use would be consistent with the Imperial County Land Use Ordinance and thus is also consistent with the General Plan land use designation of the site. Additionally, the operation of the solar generating facility is not expected to inhibit or adversely affect adjacent agricultural operations through the placement of sensitive land uses, generation of excessive dust or shading, or place additional development pressures on adjacent areas. Based on these considerations, the impact is considered less than significant.

Mitigation Measure(s)

No mitigation measures are required.

Impact 3.3-3 Would the project involve other changes in the existing environment which, due to their location or nature, could result in conversion of Farmland, to non-agricultural use?

The Agricultural Element of the County's General Plan serves as the primary policy statement for implementing development policies for agricultural land use in Imperial County. The goals, objectives, implementation programs, and policies found in the Agricultural Element provide direction



for private development as well as government actions and programs. A summary of the relevant Agricultural goals and objectives and the project's consistency with applicable goals and objectives is summarized in Table 3.3-2. As provided, the project is generally consistent with certain Agricultural Element Goals and Objectives of the County General Plan.

Per County policy, agricultural land may be converted to non-agricultural uses only where a clear and immediate need can be demonstrated, such as requirements for urban housing, commercial facilities, or employment opportunities. Further, no agricultural land designated exempt shall be removed from the agriculture category except where needed for use by a public agency, for geothermal purposes, where a mapping error may have occurred, or where a clear long-term economic benefit to the County can be demonstrated through the planning and environmental review process.

As discussed under Impact 3.3-1, the project site does not contain Prime Farmland, Farmland of Statewide Importance, or Unique Farmland. Furthermore, the project site is located within the Renewable Energy Zone and is, therefore, considered an appropriate use in this area. Additionally, as a condition of project approval (CUP condition), the project applicant or its successor in interest will be responsible for implementing a reclamation plan when the project is decommissioned at the end of its lifespan. The reclamation plan includes the removal, recycling, and/or disposal of all solar arrays, inverters, transformers, and other structures on the project site, as well as restoration of the site to its pre-project condition. The County is responsible for approving the reclamation plan for the project and confirming that financial assurances for the project are in conformance with Imperial County ordinances prior to the issuance of any building permits. This shall be made a condition of approval and included in the CUP.

The nature of the project warrants that it be located adjacent to existing electrical transmission infrastructure. The electrical energy produced by the project would be conducted through the project's interconnection facilities to the proposed 92 kV gen-tie line and delivered to the existing IID approved POI on the 92 kV "P" Line. The All-American Main Canal provides a buffer between the proposed solar facility and the existing cultivated agricultural croplands located north of the canal. With the approval of a Conditional Use Permit, the project would be consistent with the County's Land Use Ordinance. Consistency with the Land Use Ordinance implies consistency with the General Plan land use designation.

The project would not directly impact the movement of agricultural equipment on roads located within the agriculture category and access to existing agriculture-serving roads would not be precluded or hindered by the project. No modifications to roadways are proposed in the project area that would otherwise affect other agricultural operations in the area. Furthermore, existing nuisance issues, such as noise, dust, and odors from existing agricultural use would not impact the project given the general lack of associated sensitive uses (e.g., residences). Likewise, with mitigation measures proposed in other resource sections (e.g., air quality, noise, etc.) project-related activities would not adversely affect adjacent agricultural operations. Further, the provisions of the Imperial County Right-to-Farm Ordinance (No. 1031) and the State nuisance law (California Code Sub-Section 3482) would continue to be enforced.

With the implementation of the project, it is possible that the physical and chemical makeup of the soil materials within the upper soil horizon may change. For example, improper soil stockpiling and management of the stockpiles could result in increased decomposition of soil organic materials, increased leaching of plant available nitrogen, and depletion of soil biota communities (e.g., Rhizobium or Frankia). Any reductions in agricultural productivity could significantly limit the types of

crops (e.g., deeper rooting crops, orchards, etc.) that may be grown within the project site in the future. However, as a condition of project approval (CUP condition), the project applicant or its successor in interest will be responsible for implementing a reclamation plan when the project is decommissioned at the end of its lifespan. The reclamation plan includes restoration of the site to its pre-project condition.

Additionally, there is the potential that weeds or other pests may occur within the solar field if the area is not properly maintained and managed to control weeds and pests. This is considered a significant impact. Implementation of Mitigation Measure AG-1 would reduce this impact to a level less than significant.

Mitigation Measure(s)

AG-1 Pest Management Plan. Prior to the issuance of a grading permit or building permit (whichever occurs first), a Pest Management Plan shall be developed by the project applicant and approved by the County of Imperial Agricultural Commissioner. The project applicant shall maintain a Pest Management Plan until reclamation is complete. The plan shall provide the following:

1. Monitoring, preventative, and management strategies for weed and pest control during construction activities at any portion of the project (e.g., transmission line);
2. Control and management of weeds and pests in areas temporarily disturbed during construction where native seed will aid in site revegetation as follows:
 - Monitor for all pests including insects, vertebrates, weeds, and pathogens. Promptly control or eradicate pests when found, or when notified by the Agricultural Commissioner's office that a pest problem is present on the project site. The assistance of a licensed pest control advisor is recommended. All treatments must be performed by a qualified applicator or a licensed pest control business;
 - All treatments must be performed by a qualified applicator or a licensed pest control operator;
 - "Control" means to reduce the population of common pests below economically damaging levels, and includes attempts to exclude pests before infestation, and effective control methods after infestation. Effective control methods may include physical/mechanical removal, bio control, cultural control, or chemical treatments;
 - Use of "permanent" soil sterilants to control weeds or other pests is prohibited because this would interfere with reclamation;
 - Notify the Agricultural Commissioner's office immediately regarding any suspected exotic/invasive pest species as defined by the California Department of Food Agriculture and the U.S. Department of Agriculture. Request a sample be taken by the Agricultural Commissioner's Office of a suspected invasive species. Eradication of exotic pests shall be done under the direction of the Agricultural Commissioner's Office and/or California Department of Food and Agriculture;
 - Obey all pesticide use laws, regulations, and permit conditions;

- Allow access by Agricultural Commissioner staff for routine visual and trap pest surveys, compliance inspections, eradication of exotic pests, and other official duties;
 - Ensure all project employees that handle pest control issues are appropriately trained and certified, all required records are maintained and made available for inspection, and all required permits and other required legal documents are current;
 - Maintain records of pests found and treatments or pest management methods used. Records should include the date, location/block, project name (current and previous if changed), and methods used. For pesticides include the chemical(s) used, EPA Registration numbers, application rates, etc. A pesticide use report may be used for this;
 - Submit a report of monitoring, pest finds, and treatments, or other pest management methods to the Agricultural Commissioner quarterly within 15 days after the end of the previous quarter, and upon request. The report is required even if no pests were found or treatment occurred. It may consist of a copy of all records for the previous quarter or may be a summary letter/report as long as the original detailed records are available upon request.
3. A long-term strategy for weed and pest control and management during the operation of the proposed project. Such strategies may include, but are not limited to:
- Use of specific types of herbicides and pesticides on a scheduled basis.
4. Maintenance and management of project site conditions to reduce the potential for a significant increase in pest-related nuisance conditions on surrounding agricultural lands.
5. The project shall reimburse the Agricultural Commissioner's office for the actual cost of investigations, inspections, or other required non-routine responses to the site that are not funded by other sources.

Significance after Mitigation

The project applicant would be required to adhere to the terms of the comprehensive reclamation plan that would restore the project site to preexisting (pre-project) conditions following decommissioning of the project (after their use for solar generation activities). In addition, the proposed project would be required to implement a weed and pest management control plan per Mitigation Measure AG-1. Compliance with these measures would reduce this impact to a level less than significant.

3.3.4 Decommissioning/Restoration and Residual Impacts

Decommissioning/Restoration

In any land restoration project, it is necessary to minimize disruption to topsoil or stockpiled topsoil for later use during restoration following project decommissioning. With the implementation of the project, it is possible that the physical and chemical makeup of the soil materials within the upper soil

horizon may change during construction and associated stockpiling operations. Improper soil stockpiling and management of the stockpiles could result in increased decomposition of soil organic materials, increased leaching of plant-available nitrogen, and depletion of soil biota communities (e.g., Rhizobium or Frankia). Each of these circumstances could have an adverse effect on the future productivity of the restored soils. Any reductions in agricultural productivity could significantly limit the types of crops (e.g., deeper rooting crops, orchards, etc.) that may be grown within the project site in the future. As a condition of project approval (CUP condition), the project applicant or its successor in interest will be responsible for implementing a reclamation plan when the project is decommissioned at the end of its lifespan. The reclamation plan includes restoration of the site to its pre-project condition. With implementation of the site reclamation plan, this impact is considered less than significant.

Residual

The project site does not contain Prime Farmland, Farmland of Statewide Importance, or Unique Farmland. Therefore, the proposed project would not convert land designated as Prime Farmland, Farmland of Statewide Importance, or Unique Farmland to non-agricultural uses. Operation of the project, subject to the approval of a CUP, would generally be consistent with applicable federal, state, regional, and local plans and policies. Following the proposed use (e.g., solar facility), the project would be decommissioned and the project site would be restored to pre-project conditions. Based on these circumstances, the project would not result in any residual significant and unmitigable impacts to agricultural resources.

3.4 Air Quality

This section includes an overview of the existing air quality within the project area and identifies applicable local, state, and federal policies related to air quality. The impact assessment provides an evaluation of potential adverse effects on air quality based on criteria derived from the CEQA Guidelines and Imperial County Air Pollution Control District's (ICAPCD) Air Quality Handbook in conjunction with actions proposed in Chapter 2, Project Description, of this EIR. ECORP Consulting, Inc. prepared an *Air Quality and Greenhouse Gas Assessment* that evaluates the potential air quality and climate change impacts of the VEGA SES 4 Solar Energy Project. This report is included in Appendix C of this EIR.

3.4.1 Existing Conditions

Regional Setting

The project is located in Imperial County within the Salton Sea Air Basin (SSAB). The SSAB consists of all of Imperial County and a portion of Riverside County. The ICAPCD has full jurisdiction within all Imperial County. As an arid desert region, the SSAB's climate is largely governed by the large-scale sinking and warming of air within the semi-permanent subtropical high-pressure center over the Pacific Ocean. When the fringes of mid-latitude storms pass through the Imperial Valley in winter, the coastal mountains create a strong "rain shadow" effect that makes Imperial Valley the second driest location in the U.S.

The lack of clouds and atmospheric moisture creates strong diurnal and seasonal temperature variations ranging from an average summer maximum of 108 degrees (°) Fahrenheit down to a winter morning minimum of 38° Fahrenheit. The most pleasant weather occurs from about mid-October to early May when daily highs are in the 70s and 80s with very infrequent cloudiness or rainfall. Imperial County experiences significant rainfall an average of only four times per year. The local area usually has three days of rain in winter and one thunderstorm day in August. The annual rainfall in this region is less than three inches per year (Appendix C of this EIR). Temperature inversions and light nighttime winds trap any local air pollution emissions near the ground. As a result, the area is subject to frequent hazy conditions at sunrise, followed by rapid daytime dissipation as winds pick up and the temperature warms. During periods of strong solar heating and intense convection, turbulent motion creates good mixing and low levels of air pollution. The SSAB experiences surface inversions almost every day of the year. These inversions often last for long periods of time, which allows for air stagnation and buildup of pollutants, including ozone (O₃).

Winds in the area are driven by a complex pattern of local, regional, and global forces, but primarily reflect the temperature difference between the cool ocean to the west and the heated interior of the entire desert southwest. For much of the year, winds flow predominantly from the west to the east. In summer, intense solar heating in the Imperial Valley creates a more localized wind pattern, as air comes up from the southeast via the Gulf of California.

Imperial County is predominately agricultural land, which is a factor in the cumulative air quality of the SSAB. Agricultural production generates dust and small particulate matter through the use of agricultural equipment on unpaved roads, land preparation, and harvest practices. Imperial County experiences unhealthy air quality from photochemical smog and from dust because of extensive surface disturbance and the very arid climate (Appendix C of this EIR).

Major Air Pollutants

Criteria Pollutants

Criteria air pollutants are defined as those pollutants for which the federal and state governments have established air quality standards for outdoor or ambient concentrations to protect public health with a determined margin of safety. Ozone, coarse particulate matter (PM₁₀), and fine particulate matter (PM_{2.5}) are generally considered to be regional pollutants because they or their precursors affect air quality on a regional scale. Pollutants such as carbon monoxide (CO), nitrogen dioxide (NO₂), and sulfur dioxide (SO₂) are considered to be local pollutants because they tend to accumulate in the air locally. PM is also considered a local pollutant. Health effects commonly associated with criteria pollutants are summarized in Table 3.4-1.

Table 3.4-1. Criteria Air Pollutants – Summary of Common Sources and Effects

Pollutant	Major Manmade Sources	Human Health and Welfare Effects
CO	An odorless, colorless gas formed when carbon in fuel is not burned completely; a component of motor vehicle exhaust.	Reduces the ability of blood to deliver oxygen to vital tissues, effecting the cardiovascular and nervous system. Impairs vision, causes dizziness, and can lead to unconsciousness or death.
NO ₂	A reddish-brown gas formed during fuel combustion for motor vehicles, energy utilities and industrial sources.	Respiratory irritant; aggravates lung and heart problems. Precursor to ozone and acid rain. Causes brown discoloration of the atmosphere.
O ₃	Formed by a chemical reaction between reactive organic gases (ROGs) and nitrous oxides (N ₂ O) in the presence of sunlight. Common sources of these precursor pollutants include motor vehicle exhaust, industrial emissions, solvents, paints and landfills.	Irritates and causes inflammation of the mucous membranes and lung airways; causes wheezing, coughing and pain when inhaling deeply; decreases lung capacity; aggravates lung and heart problems. Damages plants; reduces crop yield.
PM ₁₀ and PM _{2.5}	Power plants, steel mills, chemical plants, unpaved roads and parking lots, wood-burning stoves and fireplaces, automobiles and others.	Increased respiratory symptoms, such as irritation of the airways, coughing, or difficulty breathing; aggravated asthma; development of chronic bronchitis; irregular heartbeat; nonfatal heart attacks; and premature death in people with heart or lung disease. Impairs visibility (haze)
SO ₂	A colorless, nonflammable gas formed when fuel containing sulfur is burned. Examples are refineries, cement manufacturing, and locomotives.	Respiratory irritant. Aggravates lung and heart problems. Can damage crops and natural vegetation. Impairs visibility.

Source: Appendix C of this EIR

Toxic Air Contaminants

Toxic air contaminants (TAC) are substances that have the potential to be emitted into the ambient air and that have been determined to present some level of acute or chronic health risk (cancer or non-cancer) to the general public. These pollutants may be emitted in trace amounts from various types of sources, including combustion sources. There are almost 200 compounds that have been designated as TACs in California. The 10 TACs posing the greatest known health risk in California, based primarily

on ambient air quality data, are acetaldehyde, benzene, 1,3-butadiene, carbon tetrachloride, hexavalent chromium, formaldehyde, methylene chloride, para-dichlorobenzene, perchloroethylene, and diesel particulate matter (DPM).

Most recently, CARB identified DPM as a TAC. DPM differs from other TACs in that it is not a single substance but rather a complex mixture of hundreds of substances. Diesel exhaust is a complex mixture of particles and gases produced when an engine burns diesel fuel. DPM is a concern because it causes lung cancer; many compounds found in diesel exhaust are carcinogenic. DPM includes the particle-phase constituents in diesel exhaust. The chemical composition and particle sizes of DPM vary between different engine types (heavy-duty, light-duty), engine operating conditions (idle, accelerate, decelerate), fuel formulations (high/low sulfur fuel), and the year of the engine. Some short-term (acute) effects of diesel exhaust include eye, nose, throat, and lung irritation, and diesel exhaust can cause coughs, headaches, light-headedness, and nausea. DPM poses the greatest health risk among the TACs; due to their extremely small size, these particles can be inhaled and eventually trapped in the bronchial and alveolar regions of the lung (Appendix C of this EIR).

Attainment Status

The U.S. Environmental Protection Agency (EPA) and California Air Resources Board (CARB) designate air basins or portions of air basins and counties as being in “attainment” or “nonattainment” for each of the criteria pollutants. Areas that do not meet the standards are classified as nonattainment areas. The National Ambient Air Quality Standards (NAAQS) (other than O₃, PM₁₀ and PM_{2.5} and those based on annual averages or arithmetic mean) are not to be exceeded more than once per year. The NAAQS for O₃, PM₁₀, and PM_{2.5} are based on statistical calculations over one- to three-year periods, depending on the pollutant. The California Ambient Air Quality Standards (CAAQS) are not to be exceeded during a three-year period.

The attainment status for the portion of the SSAB encompassing the project site is shown in Table 3.4-2. As shown, the Imperial County portion of the SSAB is currently designated as nonattainment for O₃ and PM₁₀ under State standards. Under federal standards, the Imperial County portion of the SSAB is in nonattainment for O₃ and PM_{2.5} and is in attainment for PM₁₀. The area is currently in attainment or unclassified status for CO, NO₂, and SO₂.

Table 3.4-2. Attainment Status of Criteria Pollutants in the Imperial County Portion of the Salton Sea Air Basin

Pollutant	State Designation	Federal Designation
O ₃	Nonattainment	Nonattainment
PM ₁₀	Nonattainment	Attainment
PM _{2.5}	Attainment	Nonattainment
CO	Attainment	Unclassified/attainment
NO ₂	Attainment	Unclassified/attainment
SO ₂	Attainment	Unclassified/attainment

Source: Appendix C of this EIR

Local Ambient Air Quality

Ambient air quality at the project site can be inferred from ambient air quality measurements conducted at nearby air quality monitoring stations. CARB maintains more than 60 monitoring stations throughout California. Ozone, PM₁₀ and PM_{2.5} are the pollutants most potently affecting the project region. As described above, the project region is designated as a nonattainment area for the federal O₃ and PM_{2.5} standards and is also a nonattainment area for the State standards for O₃ and PM₁₀. The Niland-English Road air quality monitoring station (7711 English Road, Niland), located approximately 23.0 miles northwest of the project site, monitors ambient concentrations of O₃ and PM₁₀. The Brawley-Main Street #2 air quality monitoring station (220 Main Street, Brawley), located 15.0 miles west of the project site, monitors ambient concentrations of PM_{2.5}. Ambient emission concentrations will vary due to localized variations in emission sources and climate and should be considered “generally” representative of ambient concentrations in the project area. Table 3.4-3 summarizes the published data concerning O₃, PM_{2.5} and PM₁₀ from the Niland-English Road and Brawley-Main Street #2 monitoring stations for monitoring years 2018-2020. As shown in Table 3.4-3, O₃, PM₁₀ and PM_{2.5} are the pollutants most potently affecting the project region.

Table 3.4-3. Summary of Local Ambient Air Quality Data

Pollutant Standards	2018	2019	2020
O₃ – Niland-English Road			
Max 1-hour concentration (ppm)	0.060	0,060	0.054
Max 8-hour concentration (ppm) (state/federal)	0.055 / 0.055	0.055 / 0.054	0.046 / 0.045
Number of days above 1-hour standard (state/federal)	0 / 0	0 / 0	0 / 0
Number of days above 8-hour standard (state/federal)	0 / 0	0 / 0	0 / 0
PM₁₀ – Niland-English Road			
Max 24-hour concentration (µg/m3) (state/federal)	333.8 / 331.5	156.3 / 155.7	241.3 / 239.8
Number of days above 24-hour standard (state/federal)	* / 10.1	49.3 / 1.0	68.9 / 1.0
PM_{2.5} – Brawley-Main Street			
Max 24-hour concentration (µg/m3) (state/federal)	55.1 / 55.1	28.9 / 28.9	23.7 / 23.7
Number of days above federal 24-hour standard	6.1	0	0

Source: Appendix C of this EIR

µg/m3 = micrograms per cubic meter; ppm = parts per million

* = Insufficient data available

Sensitive Receptors

High concentrations of air pollutants pose health hazards for the general population, but particularly for the young, the elderly, and the sick. Typical health problems attributed to smog include respiratory ailments, eye and throat irritations, headaches, coughing, and chest discomfort. Certain land uses are considered to be more sensitive to the effects of air pollution. Schools, hospitals, residences, and other

facilities where people congregate, especially children, the elderly and infirm, are considered particularly sensitive to air pollutants.

The project site is in a generally rural area and surrounded by relatively undisturbed desert lands. The nearest sensitive receptor to the project site is a single-family residence located approximately 0.5 miles from the northeastern corner of the project site.

3.4.2 Regulatory Setting

This section identifies and summarizes federal, state, and local laws, policies, and regulations that are applicable to the project.

Federal

Clean Air Act

The Federal Clean Air Act (CAA), passed in 1970 and last amended in 1990, is the primary federal law that governs air quality. The Federal CAA delegates primary responsibility for clean air to the U.S. EPA. The U.S. EPA develops rules and regulations to preserve and improve air quality and delegates specific responsibilities to state and local agencies. Under the act, the U.S. EPA has established the NAAQS for six criteria air pollutants that are pervasive in urban environments and for which state and national health-based ambient air quality standards have been established. Ozone, CO, NO₂, SO₂, Pb, and PM (including both PM₁₀, and PM_{2.5}) are the six criteria air pollutants. Ozone is a secondary pollutant, nitrogen oxides (NO_x) and volatile organic compounds (VOCs) are of particular interest as they are precursors to ozone formation. In addition, national standards exist for Pb. The NAAQS standards are set at levels that protect public health with a margin of safety and are subject to periodic review and revision.

The Federal CAA requires U.S EPA to designate areas as attainment, nonattainment, or maintenance (previously nonattainment and currently attainment) for each criteria pollutant based on whether the NAAQS have been achieved. The federal standards are summarized in Table 3.4-4.

State

California Clean Air Act

The California Clean Air Act (CCAA) was adopted by CARB in 1988. The CCAA is responsible for meeting the state requirements of the Federal CAA and for establishing the CAAQS. CARB oversees the functions of local air pollution control districts and air quality management districts, which, in turn, administer air quality activities at the regional and county levels. The CCAA, as amended in 1992, requires all air districts of the state to achieve and maintain the CAAQS by the earliest practical date.

The CCAA requires CARB to designate areas within California as either attainment or nonattainment for each criteria pollutant based on whether the CAAQS have been achieved. Under the CCAA, areas are designated as nonattainment for a pollutant if air quality data shows that a state standard for the pollutant was violated at least once during the previous 3 calendar years. As shown in Table 3.4-4, the CAAQS are generally more stringent than the corresponding federal standards and incorporate additional standards for sulfates, hydrogen sulfide, vinyl chloride, and visibility-reducing particles. Exceedances that are affected by highly irregular or infrequent events are not considered violations of a state standard and are not used as a basis for designating areas as nonattainment.

California State Implementation Plan

The CAA mandates that the state submit and implement a State Implementation Plan (SIP) for areas not meeting the NAAQS. These plans must include pollution control measures that demonstrate how the standards will be met. State law makes CARB the lead agency for all purposes related to the SIP. Local air districts and other agencies prepare SIP elements and submit them to CARB for review and approval. CARB then forwards SIP revisions to the U.S. EPA for approval and publication in the Federal Register. The Code of Federal Regulations Title 40, Chapter I, Part 52, Subpart F, Section 52.220 lists all of the items which are included in the California SIP.

Table 3.4-4. Ambient Air Quality Standards

Air Pollutant	Averaging Time	California Standard	National Standard
O ₃	1-hour	0.09 ppm	--
	8-hour	0.070 ppm	0.070 ppm
PM ₁₀	24-hour Mean	50 µg/m ³	150 µg/m ³
		20 µg/m ³	--
PM _{2.5}	24-hour Mean	--	35 µg/m ³
		12 µg/m ³	12.0 µg/m ³
CO	1-hour 8-hour	20 ppm	35 ppm
		9.0 ppm	9 ppm
NO ₂	1-hour Mean	0.18 ppm	100 ppb
		0.030 ppm	0.053 ppm
SO ₂	1-hour 24-hour	0.25 ppm	75 ppb
		0.04 ppm	--
Pb	30-day Rolling 3-month	1.5 µg/m ³	-- 0.15 µg/m ³
Sulfates	24-hour	25 µg/m ³	No federal standard
Hydrogen sulfide	1-hour	0.03 ppm	
Vinyl chloride	24-hour	0.01 ppm	
Visibility-reducing particles	8-hour	Extinction coefficient of	
		0.23 per kilometer, visibility of 10 miles or more because of particles when relative humidity is less than 70 percent	

Source: CARB 2016

CO – carbon monoxide; mean – annual arithmetic mean; NO₂ – nitrogen dioxide; O₃ – ozone; Pb – lead; PM_{2.5} – particulate matter less than 2.5 microns in diameter; PM₁₀ – particulate matter less than 10 microns in diameter; ppb – parts per billion; ppm – parts per million; SO₂ – sulfur dioxide; µg/m³ – micrograms per cubic meter

Toxic Air Contaminants Regulation

TAC sources include industrial processes, dry cleaners, gasoline stations, paint and solvent operations, and fossil fuel combustion sources. The TACs that are relevant to the implementation of the project include DPM and airborne asbestos.

In August 1998, ARB identified DPM emissions from diesel-fueled engines as a TAC. In September 2000, ARB approved a comprehensive diesel risk reduction plan to reduce emissions from both new and existing diesel fueled engines and vehicles. The goal of the plan is to reduce diesel PM₁₀ (inhalable particulate matter) emissions and the associated health risk by 75 percent in 2010 and by 85 percent by 2020. The plan identified 14 measures that target new and existing on-road vehicles (e.g., heavy duty trucks and buses, etc.), off-road equipment (e.g., graders, tractors, forklifts, sweepers, and boats), portable equipment (e.g., pumps, etc.), and stationary engines (e.g., stand-by power generators, etc.).

Tanner Air Toxics Act & Air Toxics "Hot Spots" Information and Assessment Act

CARB's Statewide comprehensive air toxics program was established in 1983 with Assembly Bill (AB) 1807, the Toxic Air Contaminant Identification and Control Act (Tanner Air Toxics Act of 1983). AB 1807 created California's program to reduce exposure to air toxics and sets forth a formal procedure for CARB to designate substances as TACs. Once a TAC is identified, CARB adopts an airborne toxics control measure (ATCM) for sources that emit designated TACs. If there is a safe threshold for a substance at which there is no toxic effect, the control measure must reduce exposure to below that threshold. If there is no safe threshold, the measure must incorporate toxics best available control technology to minimize emissions.

CARB also administers the state's mobile source emissions control program and oversees air quality programs established by state statute, such as AB 2588, the Air Toxics "Hot Spots" Information and Assessment Act of 1987. Under AB 2588, TAC emissions from individual facilities are quantified and prioritized by the air quality management district or air pollution control district. High priority facilities are required to perform a health risk assessment (HRA) and, if specific thresholds are exceeded, required to communicate the results to the public in the form of notices and public meetings. In September 1992, the "Hot Spots" Act was amended by Senate Bill (SB) 1731, which required facilities that pose a significant health risk to the community to reduce their risk through a risk management plan.

Regional

Imperial County Air Pollution Control District

The ICAPCD is the agency responsible for monitoring air quality, as well as planning, implementing, and enforcing programs designed to attain and maintain state and federal ambient air quality standards in the district. ICAPCD is responsible for regulating stationary sources of air emissions in Imperial County. Stationary sources that have the potential to emit air pollutants into the ambient air are subject to the Rules and Regulations adopted by ICAPCD. ICAPCD is responsible for establishing stationary source permitting requirements and for ensuring that new, modified, or relocated stationary sources do not create net emission increases. Monitoring of ambient air quality in Imperial County began in 1976. Since that time, monitoring has been performed by ICAPCD, CARB, and by private industry. There are six monitoring sites in Imperial County from Niland to Calexico. The ICAPCD has developed the following plans to achieve attainment for air quality ambient standards.

- 2009 Imperial County Plan for PM₁₀

- 2013 Imperial County Plan for 2006 24-hour PM_{2.5} for Moderate Nonattainment Area
- 2017 Imperial County Plan for 2008 8-hour Ozone Standard
- 2018 Imperial County Plan for PM₁₀
- 2018 Redesignation Request and Maintenance Plan for PM₁₀
- 2018 Imperial County Plan for PM_{2.5}

In addition to the above plans, the ICAPCD is working cooperatively with counterparts from Mexico to implement emissions reductions strategies and projects for air quality improvements at the border. The two countries strive to achieve these goals through local input from states, county governments, and citizens. Within the Mexicali and Imperial Valley area, the Air Quality Task Force has been organized to address those issues unique to the border region known as the Mexicali/Imperial air shed. The Air Quality Task Force membership includes representatives from federal, State, and local governments from both sides of the border, as well as representatives from academia, environmental organizations, and the general public. This group was created to promote regional efforts to improve the air quality monitoring network, emissions inventories, and air pollution transport modeling development, as well as the creation of programs and strategies to improve air quality.

Imperial County Air Pollution Control District Rules and Regulations

ICAPCD has the authority to adopt and enforce regulations dealing with controls for specific types of sources, emissions or hazardous air pollutants, and New Source Review. The ICAPCD Rules and Regulations are part of the SIP and are separately enforceable by the EPA.

Rule 106 – Abatement. The Board may, after notice and a hearing, issue, or provide for the issuance by the Hearing Board, of an order for abatement whenever the District finds that any person is in violation of the rules and regulations limiting the discharge of air contaminants into the atmosphere.

Rule 107 – Land Use. The purpose of this rule is to provide ICAPCD the duty to review and advise the appropriate planning authorities within the District on all new construction or changes in land use which the Air Pollution Control Officer believes could become a source of air pollution problems.

Rule 201 – Permits Required. The construction, installation, modification, replacement, and operation of any equipment which may emit or control Air Contaminants require ICAPCD permits.

Rule 207 – New and Modified Stationary Source Review. Establishes preconstruction review requirements for new and modified stationary sources to ensure the operations of equipment does not interfere with attainment or maintenance of ambient air quality standards.

Rule 208 – Permit to Operate. The ICAPCD would inspect and evaluate the facility to ensure the facility has been constructed or installed and will operate to comply with the provisions of the Authority to Construct permit and comply with all applicable laws, rules, standards, and guidelines.

Rule 310 – Operational Development Fee. The purpose of this rule is to provide ICAPCD with a sound method for mitigating the emissions produced from the operation of new commercial and residential development projects throughout the County of Imperial and incorporated cities. All project proponents have the option to either provide off-site mitigation, pay the operational development fee, or do a combination of both. This rule will assist ICAPCD in attaining the state and federal ambient air quality standards for PM₁₀ and O₃.

Rule 401 – Opacity of Emissions. Sets limits for release or discharge of emissions into the atmosphere, other than uncombined water vapor, that are dark or darker in shade as designated as

No.1 on the Ringelmann Chart¹ or obscure an observer's view to a degree equal to or greater than smoke does as compared to No.1 on the Ringelmann Chart, for a period or aggregated period of more than three minutes in any hour.

Rule 403 – General Limitations on the Discharge of Air Contaminants. Rule 403 sets forth limitations on emissions of pollutants, including particulate matter, from individual sources.

Rule 407 – Nuisance. Rule 407 prohibits a person from discharging from any source whatsoever such quantities of air contaminants or other material which cause injury, detriment, nuisance or annoyance to any considerable number of persons or to the public, or which endanger the comfort, repose, health or safety of any such persons or the public, or which cause, or have a natural tendency to cause, injury or damage to business or property.

Rule 801 – Construction and Earthmoving Activities. Rule 801 aims to reduce the amount of PM₁₀ entrained in the ambient air as a result of emissions generated from construction and other earthmoving activities by requiring actions to prevent, reduce, or mitigate PM₁₀ emissions. This rule applies to any construction and other earthmoving activities, including, but not limited to, land clearing, excavation related to construction, land leveling, grading, cut and fill grading, erection or demolition of any structure, cutting and filling, trenching, loading or unloading of bulk materials, demolishing, drilling, adding to or removing bulk of materials from open storage piles, weed abatement through disking, back filling, travel on-site and travel on access roads to and from the site.

Regulation VIII – Fugitive Dust Rules. Regulation VIII sets forth rules regarding the control of fugitive dust, including fugitive dust from construction activities. The regulation requires implementation of fugitive dust control measures to reduce emissions from earthmoving, unpaved roads, handling of bulk materials, and control of track-out/carry-out dust from active construction sites. Best Available Control Measures to reduce fugitive dust during construction and earthmoving activities include but are not limited to:

- Phasing of work in order to minimize disturbed surface area
- Application of water or chemical stabilizers to disturbed soils
- Construction and maintenance of wind barriers
- Use of a track-out control device or wash down system at access points to paved roads.

Compliance with Regulation VIII is mandatory for all construction sites, regardless of size; however, compliance with Regulation VIII does not constitute mitigation under the reductions attributed to environmental impacts. In addition, compliance for a project includes: (1) the development of a dust control plan for the construction and operational phase; and (2) notification to the Air District is required 10 days prior to the commencement of any construction activity. Furthermore, any use of engine(s) and/or generator(s) of 50 horsepower or greater may require a permit through ICAPCD.

Southern California Association of Governments – 2020-2045 Regional Transportation Plan/Sustainable Communities Strategy

The Southern California Association of Governments (SCAG) is the designated metropolitan planning organization for Los Angeles, Ventura, Orange, San Bernardino, Riverside, and Imperial Counties. CEQA requires that regional agencies like SCAG review projects and plans throughout its jurisdiction. SCAG, as the region's "Clearinghouse," collects information on projects of varying size and scope to

¹ The Ringelmann scale is a scale for measuring the apparent density or opacity of smoke.

provide a central point to monitor regional activity. SCAG has the responsibility of reviewing dozens of projects, plans, and programs every month. Projects and plans that are regionally significant must demonstrate to SCAG their consistency with a range of adopted regional plans and policies.

On September 3, 2020, SCAG adopted the 2020-2045 Regional Transportation Plan/Sustainable Communities Strategy (RTP/SCS) (SCAG 2020). The RTP/SCS or “Connect SoCal” includes a strong commitment to reduce emissions from transportation sources to comply with Senate Bill 375, improve public health, and meet the NAAQS as set forth by the federal CAA. The following SCAG goal is applicable to the project:

- Reduce greenhouse gas emissions and improve air quality

As a solar generation facility, the proposed project would improve air quality by reducing the use of fossil fuels in energy production. Construction of the proposed project would not exceed any ICAPCD thresholds or result in significant impacts to air quality. Although no significant air quality impact would occur during construction, all construction projects within Imperial County must comply with the requirements of ICAPCD Regulation VIII for the control of fugitive dust. PM₁₀ emissions associated with construction of the project would be reduced through compliance with ICAPCD Regulation VIII. Operation of the proposed project would not exceed any ICAPCD thresholds or result in significant impacts to air quality. Therefore, the proposed project would be consistent with this SCAG goal.

Imperial County General Plan

The Imperial County General Plan serves as the overall guiding policy for the County. The Conservation and Open Space Element includes objectives for helping the County achieve the goal of improving and maintaining the quality of air in the region. Table 3.4-5 summarizes the project’s consistency with the applicable air quality goal and objectives from the Conservation and Open Space Element. While this EIR analyzes the project’s consistency with the General Plan pursuant to State CEQA Guidelines Section 15125(d), the Imperial County Board of Supervisors ultimately determines consistency with the General Plan.

Table 3.4-5. Project Consistency with Applicable Plan Policies

Applicable Policies	Consistency Determination	Analysis
<i>Conservation and Open Space Element</i>		
Protection of Air Quality and Addressing Climate Change Goal 7: The County shall actively seek to improve the quality of air in the region.	Consistent	The proposed project would be required to comply with all applicable ICAPCD rules and requirements during construction and operation to reduce air emissions. Overall, the proposed project would improve air quality and reduce GHG emissions by reducing the amount of emissions that would be generated in association with electricity production from fossil fuel burning facilities. Therefore, the proposed project is consistent with this goal.



Table 3.4-5. Project Consistency with Applicable Plan Policies

Applicable Policies	Consistency Determination	Analysis
Objective 7.1: Ensure that all project and facilities comply with current Federal, State and local requirements for attainment of air quality objectives.	Consistent	The proposed project would comply with current federal and State requirements for attainment for air quality objectives through conformance with all applicable ICAPCD rules and requirements to reduce fugitive dust and emissions. Further, the project would comply with the ICAPCD Air Quality CEQA Handbook’s Mandatory Standard, Discretionary and Enhanced Air Quality Measures (Mitigation Measure AQ-1). Therefore, the proposed project is consistent with this objective.
Objective 7.2: Develop management strategies to mitigate fugitive dust. Cooperate with all federal and state agencies in the effort to attain air quality objectives.	Consistent	The Applicant would cooperate with all federal and State agencies in the effort to attain air quality objectives through compliance with the ICAPCD Air Quality CEQA Handbook’s Mandatory Standard, Discretionary and Enhanced Air Quality Measures (Mitigation Measure AQ-1). Therefore, the proposed project is consistent with this objective.

Source: County of Imperial 2016

3.4.3 Impacts and Mitigation Measures

This section presents the significance criteria used for considering project impacts related to air quality, the methodology employed for the evaluation, an impact evaluation, and mitigation requirements, if necessary.

Thresholds of Significance

Based on CEQA Guidelines Appendix G, project impacts related to air quality are considered significant if any of the following occur:

- Conflict with or obstruct implementation of the applicable air quality plan
- Result in a cumulatively considerable net increase of any criteria pollutant for which the project region is non-attainment under an applicable federal or state ambient air quality standard (including releasing emissions which exceed quantitative thresholds for O₃ precursors)
- Expose sensitive receptors to substantial pollutant concentrations
- Result in other emissions (such as those leading to odors) adversely affecting a substantial number of people

Imperial County Air Pollution Control District

ICAPCD amended the Air Quality Handbook: Guidelines for the Implementation of CEQA on December 12, 2017 (ICAPCD 2017b). ICAPCD established significance thresholds based on the state CEQA thresholds. The handbook was used to determine the proper level of analysis for the project.

Significance thresholds for evaluation construction and operational air quality impacts are listed in Table 3.4-6.

Projects that are predicted to exceed Tier I thresholds require implementation of applicable ICAPCD standard mitigation measures to be considered less than significant. Projects exceeding Tier II

thresholds are required to implement applicable ICAPCD standard mitigation measures, as well as applicable discretionary mitigation measures. Projects that exceed the Tier II thresholds after implementation of standard and discretionary mitigation measures would be considered to have a potentially significant impact to human health and welfare.

By its very nature, air pollution is largely a cumulative impact. No single project is sufficient in size, by itself, to result in nonattainment of ambient air quality standards. Instead, a project's individual emissions contribute to existing cumulatively significant adverse air quality impacts. If a project's individual emissions exceed its identified significance thresholds, the project would be cumulatively considerable. Projects that do not exceed significance thresholds would not be considered cumulative considerable.

Table 3.4-6. Imperial County Air Pollution Control District Significance Thresholds – Pounds per Day

Criteria Pollutant and Precursors	Construction Activities	Tier 2 Thresholds	
	Average Daily Emissions (lbs/day)	Average Daily Emissions (lbs/day)	
		Tier I Threshold	Tier II Threshold
ROG	75	<137	>137
NO _x	100	<137	>137
PM ₁₀	150	<150	>150
PM _{2.5}	N/A	<550	>550
CO	550	<550	>550
SO ₂	N/A	<150	>150

Source: ICAPCD 2017b

CO – carbon monoxide; NO_x – nitrogen oxide; O₃ – ozone; Pb – lead; PM_{2.5} – particulate matter less than 2.5 microns in diameter; PM₁₀ – particulate matter less than 10 microns in diameter; ROG – reactive organic gas; SO_x – sulfur oxide

Methodology

Air quality impacts were assessed in accordance with methodologies recommended by the ICAPCD. Where criteria air pollutant quantification was required, emissions were modeled using the California Emissions Estimator Model (CalEEMod), version 2020.4.0. CalEEMod is a statewide land use emissions computer model designed to quantify potential criteria pollutant emissions associated with both construction and operations from a variety of land use projects. Project construction-generated air pollutant emissions were calculated using CalEEMod model defaults for Imperial County coupled with information provided by the project applicant. For instance, construction activities would primarily involve demolition and grubbing, grading of the project site to establish access roads and pads for electrical equipment, trenching for underground electrical collection lines, and the installation of solar equipment and security fencing. Construction is estimated to take 12-18 months and would begin in late 2022 or 2023. The number of on-site construction workers for the solar facility is not expected to exceed 150 workers at any time. The number of on-site construction workers for the BESS and substation is not expected to exceed 100 workers at any one time. According to the Traffic Study prepared for the project, project construction would generate a maximum of 500 construction worker-commute trips in a single day.

Construction workers would utilize an existing driveway off State Route 98 and then park their vehicles in a designated staging/parking area, approximately 3.5 acres in size, north of the All-American Canal. The staging/parking area is proposed to be improved to facilitate access and minimize parking conflicts. Construction workers would then walk across the All-American Canal at an existing crossing east of the project site. No vehicles or construction vehicles are allowed to travel across this existing crossing. Designated shuttles would pick up the construction workers at the south end of the crossing, and then travel west for approximately one mile along an existing dirt road to the project site. The Traffic Impact Study prepared for the project identifies the site trip distribution of construction worker commute traffic. It is noted that all of the roadways identified as construction worker commute routes are paved. Thus, the PM emissions associated with construction workers traversing 1.15 miles of unpaved roads are accounted (0.15 mile of roadway at staging/parking area and 1.0 mile of dirt road south of the All-American Canal).

All heavy-duty construction vehicles would cross the All-American Canal at Gordon Wells Road located approximately 20 miles east of the project site. An estimated two trucks hauling construction equipment and project materials would arrive at the project site each day during the first few weeks of construction via Gordon Wells Road and the 20 miles of existing dirt road paralleling the U.S./Mexico Border. The PM emissions associated with two haul trucks traversing this existing dirt road to and from the site daily are accounted for.

Operational air pollutant emissions account for the maximum three workers visiting the site in a single day. Such visits include inspections, equipment servicing, site and landscape clearing, and periodic washing of the PV modules if needed (up to two times per year) to maintain power generation efficiency. Therefore, operational onsite equipment use is accounted in addition to the consumption of 10 acre-feet (3,259,000 gallons) of water annually.

Impact Analysis

Impact 3.4-1 Would the project conflict with or obstruct implementation of the applicable air quality plan?

The air quality attainment plan (AQAP) for the SSAB, through the implementation of the AQMP (previously AQAP) and SIP for PM₁₀, sets forth a comprehensive program that will lead the SSAB into compliance with all federal and state air quality standards. The AQMP control measures and related emission reduction estimates are based upon emissions projections for a future development scenario derived from land use, population, and employment characteristics defined in consultation with local governments. Conformance with the AQMP for development projects is determined by demonstrating compliance with local land use plans and/or population projections, meeting the land use designation set forth in the local General Plan, and comparing assumed emissions in the AQMP to proposed emissions.

The project must demonstrate compliance with all ICAPCD applicable rules and regulations, as well as local land use plans and population projections. As the project does not contain a residential component, the project would not result in an increase in the regional population. While the project would contribute to energy supply, which is one factor of population growth, the proposed project is a solar energy project and would not significantly increase employment or growth within the region. Moreover, development of the proposed project would increase the amount of renewable energy and help California meet its Renewable Portfolio Standard (RPS).

As shown in Table 3.4-5, the project is consistent with the applicable air quality goal and objectives from the Conservation and Open Space Element of the General Plan. The proposed project would be required to comply with all applicable ICAPCD rules and requirements during construction and operation to reduce air emissions. Overall, the proposed project would improve air quality by reducing the amount of emissions that would be generated in association with electricity production from fossil fuel burning facilities.

Furthermore, the thresholds of significance adopted by the air district (ICAPCD), determine compliance with the goals of the attainment plans in the region. As such, emissions below the ICAPCD thresholds presented in Table 3.4-6 would not conflict with or obstruct implementation of the applicable air quality plans. The following analysis is broken out by a discussion of potential impacts during construction of the project followed by a discussion of potential impacts during operation of the project.

Construction Emissions. Air emissions are generated during construction through activities. Two basic sources of short-term emissions will be generated through project construction: operation of heavy-duty equipment (i.e., excavators, loaders, haul trucks) and the creation of fugitive dust during clearing, grading, and commuting on any exposed surfaces. The project site would be accessed via the following:

- **Worker Access:** Workers would utilize an existing driveway off State Route 98. Workers would cross the All-American Canal at an existing crossing east of the project site and then travel west for approximately one mile along an existing dirt road.
- **Heavy Construction Equipment Access:** Vendors and heavy construction equipment would exit south from Interstate 8 onto Gordon Wells Road approximately 20 miles east of the project site, then travel west along an existing dirt road paralleling the U.S./Mexico Border.

Construction activities such as excavation and grading operations, construction vehicle traffic, and wind blowing over exposed soils would generate exhaust emissions and fugitive PM emissions that affect local air quality at various times during construction. Construction emissions vary from day-to-day depending on the number of workers, number, and types of active heavy-duty vehicles and equipment, level of activity, the prevailing meteorological conditions, and the length over which these activities occur.

The proposed project is anticipated to take approximately 12-18 months from the commencement of the construction process to complete. Construction is anticipated to begin in late 2022 and/or 2023. Construction activities would primarily involve demolition and grubbing, grading of the project site to establish access roads and pads for electrical equipment, trenching for underground electrical collection lines, and the installation of solar equipment and security fencing. The construction emissions were calculated using the CARB-approved CalEEMod computer program, which is designed to model emissions for land use development projects, based on typical construction requirements.

The total emissions generated within each year of project construction are shown in Table 3.4-7.



Table 3.4-7. Project Construction-Generated Emissions – Unmitigated

Construction Year	Pollutant (pounds per day)					
	ROG	NO _x	CO	SO ₂	PM ₁₀	PM _{2.5}
Construction in Calendar Year One	5.66	57.65	53.83	0.10	949.93	96.64
Construction in Calendar Year Two	5.18	30.12	52.46	0.09	949.82	96.54
ICAPCD Significance Threshold	75	100	550	—	150	—
Exceed ICAPCD Significance Threshold?	No	No	No	No	Yes	No

Source: Appendix C of this EIR

Notes: Pounds per day taken from the season with the highest output.

As shown in Table 3.4-7, the project’s daily construction emissions would not exceed the ICAPCD thresholds for ROG, NO_x, CO, SO₂, and PM_{2.5}. However, the project would exceed the ICAPCD threshold for PM₁₀. Pursuant to ICAPCD, all construction sites, regardless of size, must comply with the requirements contained within Regulation VIII – Fugitive Dust Control Measures. The project must comply with the requirements of ICAPCD Regulation VIII for the control of fugitive dust. A predominate source of project PM₁₀ emissions is workers commuting to and from the project site on unpaved roads (worker access and heavy construction equipment access routes described above). Regulation VIII requires all unpaved roadways, on- and off-site, to be conditioned and maintained with soil stabilizers to reduce dust opacity to no more than 20 percent; all unpaved disturbed surfaces, on- and off-site, to be stabilized with a dust suppressant, watering, or soil stabilizers to reduce opacity to no greater than 20 percent; and to reduce vehicle speed to no greater than 15 mph on all unpaved surfaces. Table 3.4-8 shows the project’s emissions with implementation of the Regulation VIII fugitive dust control measures (Mitigation Measure AQ-1). With implementation of Mitigation Measure AQ-1, the project would not exceed the ICAPCD’s thresholds of significance for PM₁₀ emissions.

Table 3.4-8. Project Construction-Generated Emissions – Mitigated

Construction Year	Pollutant (pounds per day)					
	ROG	NO _x	CO	SO ₂	PM ₁₀	PM _{2.5}
Construction in Calendar Year One	5.66	57.61	53.83	0.10	91.86	11.00
Construction in Calendar Year Two	5.18	30.03	52.46	0.09	91.75	10.90
ICAPCD Significance Threshold	75	100	550	—	150	—
Exceed ICAPCD Significance Threshold?	No	No	No	No	No	No

Source: Appendix C of this EIR

In addition, as described in Mitigation Measure AQ-2, construction equipment shall be equipped with an engine designation of EPA Tier 2 or better (Tier 2+). A list of the construction equipment, including all off-road equipment utilized at the project site by make, model, year, horsepower and expected/actual hours of use, and the associated EPA Tier shall be submitted to the County Planning and Development Services Department and ICAPCD prior to the issuance of a grading permit. The equipment list shall be submitted periodically to ICAPCD to perform a NO_x analysis. ICAPCD shall

utilize this list to calculate air emissions to verify that equipment use does not exceed significance thresholds.

Operational Emissions. The proposed project requires minimal operations and maintenance activities conducted by two to three employees. Project-generated increases in emissions would be predominately associated with motor vehicle use for routine maintenance work and site security as well as panel upkeep and cleaning. Long-term operational emissions attributable to the project are identified in Table 3.4-9 and compared to the operational significance thresholds promulgated by the ICAPCD.

Table 3.4-9. Project Operational Emissions

Emission Source	Pollutant (pounds per day)					
	ROG	NO _x	CO	SO ₂	PM ₁₀	PM _{2.5}
Summer Emissions						
Area	13.59	0.00	0.06	0.00	0.00	0.00
Energy	0.26	2.42	2.03	0.01	0.18	0.18
Mobile	0.02	0.03	0.31	0.00	4.84	0.49
Offroad Equipment	1.16	11.09	12.70	0.02	0.56	0.51
Total	15.04	13.55	15.11	0.03	5.59	1.19
ICAPCD Significance Threshold	137	137	150	550	550	150
Exceed ICAPCD Significance Threshold?	No	No	No	No	No	No
Winter Emissions						
Area	13.59	0.00	0.06	0.00	0.00	0.00
Energy	0.26	2.42	2.03	0.01	0.18	0.18
Mobile	0.02	0.03	0.24	0.00	4.84	0.49
Offroad Equipment	1.16	11.09	12.70	0.02	0.56	0.51
Total	15.04	13.55	15.04	0.03	5.59	1.19
ICAPCD Significance Threshold	137	137	150	550	550	150
Exceed ICAPCD Significance Threshold?	No	No	No	No	No	No

Source: Appendix C of this EIR

As shown in Table 3.4-9, the project’s operational emissions would not exceed the ICAPCD thresholds for CO, ROG, NO_x, PM₁₀ and PM_{2.5}. Although no significant air quality impact would occur during operation, the project applicant is required to submit a Dust Suppression Management Plan for both construction and operation in order to reduce fugitive dust emissions. Implementation of Mitigation Measures AQ-1, AQ-3, and AQ-4 would ensure that a Dust Suppression Management Plan is implemented, thereby ensuring that this potential impact would remain less than significant.



As a solar generation facility, the proposed project would improve air quality by reducing the use of fossil fuels in energy production. The energy produced by the project would displace the criteria pollutant emissions which would otherwise be produced by existing business-as-usual power generation resources (including natural gas and coal). Table 3.4-10 shows the emissions that would potentially be displaced by the proposed project. Displacement of fossil fuel emissions has a direct beneficial effect on human health for those receptors downwind of the location of the fossil fuel power plants. As shown, the project would potentially displace approximately 483 tons of NO_x, 37 tons of CO, 64 tons of SO₂, 64 tons of PM₁₀, and 27 tons of PM_{2.5} over the course of 30 years.

Table 3.4-10. Proposed Project Displaced Criteria Pollutant Emissions (Tons)

Source of Displaced Emissions	Emissions (tons)					
	ROG	NO _x	CO	SO ₂	PM ₁₀	PM _{2.5}
Emissions Displaced Annually (tons)						
Displaced Natural Gas-Source Emissions	0	2.14	0.65	1.47	2.03	0.82
Displaced Coal-Source Emissions	0	13.97	0.58	0.66	0.10	0.07
Total	0	16.11	1.23	2.13	2.13	0.89
Emissions Displaced over 30 Years (tons)						
Total	0	483.37	36.93	64.03	63.93	26.75

Source: Appendix C of this EIR

Note: Note that this estimate only includes that associated with the combustion of fossil fuels; it does not include the vehicle trips associated with the project's operations, and it similarly does not include operational employee trips associated with natural gas or coal combustion nor the emissions associated with extracting and transporting those power sources. In addition, this estimate only includes the displacement of that portion of the California market that comes from fossil fuels and does not include the approximate 50 percent of the California electricity generated by non-combustion sources (wind, solar, nuclear, hydro-electric) (See Appendix C for details).

As described above, conformance with the AQMP for development projects is determined by demonstrating compliance with local land use plans and/or population projections and comparing assumed emissions in the AQMP to proposed emissions. Because the proposed project complies with local land use plans and population projections and would not exceed ICAPCD's regional mass daily emissions thresholds during construction (with implementation of Mitigation Measure AQ-1) and operation, the proposed project would not conflict with or obstruct implementation of the applicable air quality plan. Furthermore, the project would also have a direct beneficial effect on human health by displacing criteria pollutants. Impacts would be less than significant impact with mitigation incorporated.

Mitigation Measure(s)

AQ-1 Fugitive Dust Control. During construction activities, the constructor contractor shall employ the following PM₁₀ reducing measures:

1. All unpaved roads associated with construction shall be effectively stabilized of dust emissions using Imperial County Air Pollution Control District-approved chemical stabilizers/suppressant before the commencement of construction, and every 30 days thereafter until the end of all construction activities. Unpaved roads associated with construction include:
 - The driveway entrance off State Route 98,

- The project designated 3.5-acre staging/parking area north of the All-American Canal,
- The 1.0 mile of dirt road south of the All-American Canal,
- The 20 miles of existing dirt road paralleling the U.S./Mexico Border from Gordon Wells Road to the project site.

Monthly application of Imperial County Air Pollution Control District-approved chemical stabilizers/suppressant shall be applied at a rate of 0.1 gallon/ square yard of chemical dust suppressant.

2. Prior to any earthmoving activity, the applicant shall submit a construction dust control plan and obtain Imperial County Air Pollution Control District and Imperial County Planning and Development Services Department (ICPDS) approval.
3. Pursuant to ICAPCD, all construction sites, regardless of size, must comply with the requirements contained within Regulation VIII – Fugitive Dust Control Measures. Whereas these Regulation VIII measures are mandatory and are not considered project environmental mitigation measures, the ICAPCD CEQA Handbook’s required additional standard and enhanced mitigation measures listed below shall be implemented prior to and during construction. ICAPCD will verify implementation and compliance with these measures as part of the grading permit review/approval process.

ICAPCD Standard Measures for Fugitive Dust (PM₁₀) Control

- All disturbed areas, including bulk material storage, which is not being actively utilized, shall be effectively stabilized and visible emissions shall be limited to no greater than 20 percent opacity for dust emissions by using water, chemical stabilizers, dust suppressants, tarps, or other suitable material, such as vegetative ground cover.
- All on-site and off-site unpaved roads will be effectively stabilized, and visible emissions shall be limited to no greater than 20 percent opacity for dust emissions by paving, chemical stabilizers, dust suppressants, and/or watering.
- All unpaved traffic areas 1 acre or more with 75 or more average vehicle trips per day will be effectively stabilized and visible emissions shall be limited to no greater than 20 percent opacity for dust emissions by paving, chemical stabilizers, dust suppressants, and/or watering.
- The transport of bulk materials shall be completely covered unless 6 inches of freeboard space from the top of the container is maintained with no spillage and loss of bulk material. In addition, the cargo compartment of all haul trucks is to be cleaned and/or washed at delivery site after removal of bulk material.
- All track-out or carry-out will be cleaned at the end of each workday or immediately when mud or dirt extends a cumulative distance of 50 linear feet or more onto a paved road within an urban area.
- Movement of bulk material handling or transfer shall be stabilized prior to handling or at points of transfer with application of sufficient water, chemical stabilizers, or by sheltering or enclosing the operation and transfer line.

- The construction of any new unpaved road is prohibited within any area with a population of 500 or more unless the road meets the definition of a temporary unpaved road. Any temporary unpaved road shall be effectively stabilized, and visible emissions shall be limited to no greater than 20 percent opacity for dust emission by paving, chemical stabilizers, dust suppressants, and/or watering.

ICAPCD “Discretionary” Measures for Fugitive Dust (PM₁₀) Control

- Water exposed soil only in those areas where active grading and vehicle movement occurs with adequate frequency to control dust.
- Replace ground cover in disturbed areas as quickly as possible.
- Automatic sprinkler system installed on all soil piles.
- Vehicle speed for all construction vehicles shall not exceed 15 miles per hour on any unpaved surface at the construction site.
- Develop a trip reduction plan to achieve a 1.5 average vehicle ridership for construction employees.
- Implement a shuttle service to and from retail services and food establishments during lunch hours.

Standard Mitigation Measures for Construction Combustion Equipment

- Use of alternative fueled or catalyst equipped diesel construction equipment, including all off-road and portable diesel-powered equipment.
- Minimize idling time either by shutting equipment off when not in use or reducing the time of idling to 5 minutes as a maximum.
- Limit, to the extent feasible, the hours of operation of heavy-duty equipment and/or the amount of equipment in use.
- Replace fossil fueled equipment with electrically driven equivalents (provided they are not run via a portable generator set).

Enhanced Mitigation Measures for Construction Equipment

To help provide a greater degree of reduction of PM emissions from construction combustion equipment, ICAPCD recommends the following enhanced measures.

- Curtail construction during periods of high ambient pollutant concentrations; this may include ceasing of construction activity during the peak hour of vehicular traffic on adjacent roadways.
- Implement activity management (e.g., rescheduling activities to reduce short-term impacts).

AQ-2

Construction Equipment. Construction equipment shall be equipped with an engine designation of EPA Tier 2 or better (Tier 2+). A list of the construction equipment, including all off-road equipment utilized at the project site by make, model, year, horsepower and expected/actual hours of use, and the associated EPA Tier shall be submitted to the County Planning and Development Services Department and ICAPCD prior to the issuance of a grading permit. The equipment list shall be submitted periodically to ICAPCD to perform a NO_x analysis. ICAPCD shall utilize this

list to calculate air emissions to verify that equipment use does not exceed significance thresholds. The Planning and Development Services Department and ICAPCD shall verify implementation of this measure.

AQ-3 Dust Suppression. The project applicant shall employ a method of dust suppression (such as water or chemical stabilization) approved by ICAPCD. The project applicant shall apply chemical stabilization as directed by the product manufacturer to control dust between the panels as approved by ICAPCD, and other non-used areas (exceptions will be the paved entrance and parking area, and Fire Department access/emergency entry/exit points as approved by Fire/Office of Emergency Services [OES] Department).

AQ-4 Operational Dust Control Plan. Prior to issuance of a Certificate of Occupancy, the applicant shall submit an operations dust control plan and obtain ICAPCD and ICPDS approval.

ICAPCD Rule 301 Operational Fees apply to any project applying for a building permit. At the time that building permits are submitted for the proposed project, ICAPCD shall review the project to determine if Rule 310 fees are applicable to the project.

Significance After Mitigation

With implementation of the Regulation VIII fugitive dust control measures (Mitigation Measure AQ-1), the project would not exceed the ICAPCD's thresholds of significance for PM₁₀ emissions. Mitigation Measures AQ-2 through AQ-4 would provide additional reduction strategies to further improve air quality and reductions in criteria pollutants (O₃ precursors) and ensure that this potential impact would remain less than significant. Given the above, the proposed project would not conflict with implementation of applicable air quality plans, and impacts would be less than significant impact.

Impact 3.4-2 Would the project result in a cumulatively considerable net increase of any criteria pollutant for which the project region is non-attainment under an applicable federal or state ambient air quality standard (including releasing emissions which exceed quantitative thresholds for O₃ precursors)?

As shown in Table 3.4-2, the criteria pollutants for which the project area is in State non-attainment under applicable air quality standards are O₃ and PM₁₀. The ICAPCD's application of thresholds of significance for criteria air pollutants is relevant to the determination of whether a project's individual emissions would have a cumulatively significant impact on air quality. As discussed above in Impact 3.4-1, the project's daily construction emissions would not exceed the ICAPCD thresholds for ROG, NO_x, CO, SO₂, and PM_{2.5}. However, the project would exceed the ICAPCD threshold for PM₁₀. To mitigate the potential impacts associated with construction-generated emissions with regard to PM₁₀, the project would adhere to the requirements of ICAPCD Regulation VIII for the control of fugitive dust. As shown in Table 3.4-8, the project's emissions with implementation of the Regulation VIII fugitive dust control measures, the project would not exceed the ICAPCD's threshold of significance for PM₁₀ emissions. Furthermore, implementation of Mitigation Measures AQ-1 through AQ-5 will ensure compliance with ICAPCD rules and regulations and applicable air quality plan control measures. Therefore, the project's potential to result in a cumulatively considerable net increase of any criteria pollutant is considered less than significant.

Mitigation Measure(s)

No mitigation measures are required.

Impact 3.4-3 Would the project expose sensitive receptors to substantial pollutant concentrations?

The project site is in a generally rural area and surrounded by undeveloped land, portions of which have been disturbed associated with previous agricultural-related activities to the west and east, the All-American Canal running southwest on the northern border of the project site, and the U.S./Mexico international border to the south. The nearest sensitive receptor to the project site is a single-family residence located to the northeast, approximately 0.5 miles from the northeastern corner of the project site.

Construction-Generated Air Contaminants. Construction of the project would result in temporary, short-term project-generated emissions of DPM, ROG, NO_x, CO, and PM₁₀ from the exhaust of off-road, heavy-duty diesel equipment; soil hauling truck traffic; paving; and other miscellaneous activities. The portion of the SSAB which encompasses the project area is designated as a nonattainment area for federal O₃, PM_{2.5} and PM₁₀ standards and is also a nonattainment area for the state standards for O₃ and PM₁₀. Thus, existing O₃ and PM₁₀ levels in the SSAB are at unhealthy levels during certain periods. However, as shown in Table 3.4-7, the project would exceed the ICAPCD's significance threshold for PM₁₀. As previously described above, with implementation of the Regulation VIII fugitive dust control measures (Mitigation Measure AQ-1), the project would not exceed the ICAPCD's thresholds of significance for PM₁₀ emissions. The health effects associated with O₃ are generally associated with reduced lung function. Because the project would not involve construction activities that would result in O₃ precursor emissions (ROG or NO_x) in excess of the ICAPCD thresholds, the project is not anticipated to substantially contribute to regional O₃ concentrations and the associated health impacts.

CO tends to be a localized impact associated with congested intersections. In terms of adverse health effects, CO competes with oxygen, often replacing it in the blood, reducing the blood's ability to transport oxygen to vital organs. The results of excess CO exposure can include dizziness, fatigue, and impairment of central nervous system functions. The project would not involve activities that would result in CO emissions in excess of the ICAPCD thresholds. Thus, the project's CO emissions would not contribute to the health effects associated with this pollutant.

Particulate matter (PM₁₀ and PM_{2.5}) contains microscopic solids or liquid droplets that are so small that they can get deep into the lungs and cause serious health problems. Particulate matter exposure has been linked to a variety of problems, including premature death in people with heart or lung disease, nonfatal heart attacks, irregular heartbeat, aggravated asthma, decreased lung function, and increased respiratory symptoms such as irritation of the airways, coughing, or difficulty breathing. For construction-type activity, DPM is the primary TAC of concern. PM₁₀ exhaust is considered a surrogate for DPM as all diesel exhaust is considered to be DPM. Most PM₁₀ exhaust derives from combustion, such as use of gasoline and diesel fuels by motor vehicles. As with O₃ and NO_x, the project would not generate emissions of PM₁₀ or PM_{2.5} that would exceed the ICAPCD's thresholds. Accordingly, the project's PM₁₀ and PM_{2.5} emissions are not expected to cause any increase in related regional health effects for these pollutants.

Operational Air Contaminants. Operation of the proposed project would not result in the development of any substantial sources of air toxics. There would be no stationary sources associated project operations; nor would the project attract additional mobile sources that spend long periods

queuing and idling at the site. Onsite project emissions would not result in significant concentrations of pollutants at nearby sensitive receptors as the predominant operational emissions associated with the proposed project would be routine maintenance work, water deliveries, and site security as well as panel upkeep and cleaning. Therefore, the project would not be a substantial source of TACs. The proposed project would not result in a high carcinogenic or non-carcinogenic risk during operation.

CO concentrations close to congested intersections that experience high levels of traffic and elevated background concentrations may reach unhealthy levels, affecting nearby sensitive receptors. Given the high traffic volume potential, areas of high CO concentrations, or “hot spots,” are typically associated with intersections that are projected to operate at unacceptable levels of service during the peak commute hours. CO concentration in the SSAB is designated as an attainment area. Detailed modeling of Project-specific CO “hot spots” is not necessary and thus this potential impact is addressed qualitatively.

The proposed project is anticipated to result in no more than 6 daily traffic trips. It is noted that this is a conservative estimate, and many days will have no operational related vehicle trips. Thus, the proposed project would not generate traffic volumes at any intersection of more than 100,000 vehicles per day (or 44,000 vehicles per day) and there is no likelihood of the project traffic exceeding CO values.

In summary, project construction and operations would not result in a potentially significant contribution to regional concentrations of nonattainment pollutants and would not result in a significant contribution to the adverse health impacts associated with those pollutants. Additionally, given that the nearest sensitive receptor is approximately 0.5 miles from the northeastern corner of the project site, implementation of the project would not expose sensitive receptors to substantial pollutant concentrations, and impacts would be less than significant.

Mitigation Measure(s)

No mitigation measures are required.

Impact 3.4-4 Would the project result in other emissions (such as those leading to odors) adversely affecting a substantial number of people?

An odor impact depends on numerous factors, including the nature, frequency, and intensity of the source; wind speed and direction; and the sensitivity of the receptors. While offensive odors rarely cause any physical harm, they still can be very unpleasant, leading to considerable distress among the public and often generating citizen complaints to local governments and regulatory agencies.

Among possible physical harms is inhalation of VOCs that cause smell sensations in humans. These odors can affect human health in four primary ways:

- The VOCs can produce toxicological effects
- The odorant compounds can cause irritations in the eye, nose, and throat
- The VOCs can stimulate sensory nerves that can cause potentially harmful health effects
- The exposure to perceived unpleasant odors can stimulate negative cognitive and emotional responses based on previous experiences with such odors

Land uses commonly considered to be potential sources of odorous emissions include wastewater treatment plants, sanitary landfills, food processing facilities, chemical manufacturing plants, rendering

plants, paint/coating operations, and concentrated agricultural feeding operations and dairies. The construction and operation of a solar farm is not an odor producer.

During construction, the proposed project presents the potential for generation of objectionable odors in the form of diesel exhaust in the immediate vicinity of the site. However, these emissions are short-term in nature and will rapidly dissipate and be diluted by the atmosphere downwind of the emission sources. Additionally, odors would be localized and generally confined to the project area. Therefore, odors generated during project construction would not adversely affect a substantial number of people to odor emissions. No impact would occur.

Mitigation Measure(s)

No mitigation measures are required.

3.4.4 Decommissioning/Restoration and Residual Impacts

Decommissioning/Restoration

If at the end of the PPA term, no contract extension is available for a power purchaser, no other buyer of the energy emerges, or there is no further funding of the project, the project will be decommissioned and dismantled. Similar to construction activities, decommissioning and restoration of the project site would generate air emissions. A summary of the daily construction emissions for the project is provided in Table 3.4-7. Solar equipment has a lifespan of approximately 20 to 25 years. The emissions from on- and off-road equipment during decommissioning are expected to be significantly lower than project construction emissions, as the overall activity would be anticipated to be lower than project construction activity. No significant air quality impacts are anticipated during decommissioning and restoration of the project site. However, all construction projects within Imperial County must comply with the requirements of ICAPCD Regulation VIII for the control of fugitive dust. In addition, the ICAPCD's Air Quality Handbook lists additional feasible mitigation measures that may be warranted to control emissions of fugitive dust and combustion exhaust. Mitigation Measures AQ-1 through AQ-4 would provide additional reduction strategies to further improve air quality. Therefore, a less than significant impact is identified during decommissioning and site restoration of the project site.

Residual

The proposed project's daily construction emissions would not exceed the ICAPCD's thresholds for ROG, NO_x, CO, SO₂, and PM_{2.5}. However, the project would exceed the ICAPCD's threshold for PM₁₀. To mitigate the potential impacts associated with construction-generated emissions with regard to PM₁₀, the project would adhere to the requirements of ICAPCD Regulation VIII for the control of fugitive dust (Mitigation Measure AQ-1). Thus, the proposed project would not result in short-term significant air quality impacts during construction. Furthermore, implementation of Mitigation Measure AQ-2 would ensure construction equipment will be equipped with an engine designation of EPA Tier 2 or better (Tier 2+). ICAPCD will utilize this list to calculate air emissions to verify that equipment use does not exceed significance thresholds. Operation of the project, subject to the approval of a CUP, would be consistent with applicable federal, state, regional, and local plans and policies. Implementation of Mitigation Measures AQ-1, AQ-3, and AQ-4 would ensure that fugitive dust emissions would be reduced during construction and operations. The project would not result in any residual operational significant and unavoidable impacts with regards to air quality.

This page is intentionally blank.

3.5 Biological Resources

This section identifies the biological resources that may be impacted by the proposed project. The following identifies the existing biological resources on the project site, analyzes potential impacts of the proposed project, and recommends mitigation measures to avoid or reduce potential impacts of the proposed project.

The existing biological resources information for this section is summarized from the following technical reports:

- *Biological Resources Technical Report* (BRTR) prepared by ECORP Consulting Inc. (Appendix D of this EIR)
- *Aquatic Resources Delineation Report* prepared by ECORP Consulting Inc. (Appendix E of this EIR)

As part of the *Biological Resources Technical Report*, ECORP Consulting Inc. conducted a literature review, small unmanned aircraft system survey, and biological reconnaissance survey of the project site to document the existing biological resources, to assess the habitat for its potential to support sensitive plant and wildlife species, and to determine the potential impacts of the project on biological resources.

For the purposes of this EIR, the term biological study area (BSA) refers to the project footprint, a 500-foot buffer, and areas subject to temporary impacts.

The *Aquatic Resources Delineation Report* identifies the aquatic resources occurring within the project site that may be regulated by the Porter-Cologne Water Quality Act, California Fish and Game Code Sections 1600 and 1602, and the U.S. Army Corps of Engineers (USACE) pursuant to Sections 401 and 404 of the federal Clean Water Act (CWA).

3.5.1 Existing Conditions

The project site consists of undeveloped land that appears to have been historically altered for agricultural purposes. Specifically, the disturbed nature of the site, including flora composition, old agricultural foundations, and farming equipment including a center-pivot irrigation system, indicates that portions of the land may have been historically used for agricultural production. The eastern portion of the site consists primarily of creosote bush scrub with bordering riparian scrub and wetland habitats to the northern edge and western section. The project site is surrounded to the north and southwest by agricultural fields, and undeveloped land to the east and southeast. The All-American Canal is just north of the site and the U.S./Mexico border is located just south of the site.

Vegetation Communities and Land Cover Types

The majority of vegetation communities and land cover types mapped within the BSA consists of creosote bush – white bursage scrub (disturbed), disturbed land, and tamarisk thickets. Vegetation communities and land cover types within the BSA are depicted on Figure 3.5-1 through Figure 3.5-9 and summarized in Table 3.5-1.

Table 3.5-1. Vegetation Communities or Land Cover Types within the BSA

Vegetation Community or Land Cover Type	Acres within BSA ^a
Arrow Weed Thickets (disturbed)	10.41
Creosote Bush Scrub	9.45
Creosote Bush – White Bursage Scrub (disturbed)	181.56
Disturbed	159.73
Tamarisk Thickets	66.28
Urban/Developed	0.75
Urban/Developed Roads	73.37
Total	501.55

Source: Appendix D of this EIR

^a Vegetation and land cover type acreages are rounded to the nearest hundredth acre.

Disturbed Arrow Weed Thickets (Disturbed Pluchea sericea Shrubland Alliance)

Disturbed arrow weed thickets are arrow weed thickets that has been previously altered. On the project site, this vegetation cover is characterized as sparser. Other plant species observed included alkali goldenbush (*Isocoma acradenia*).

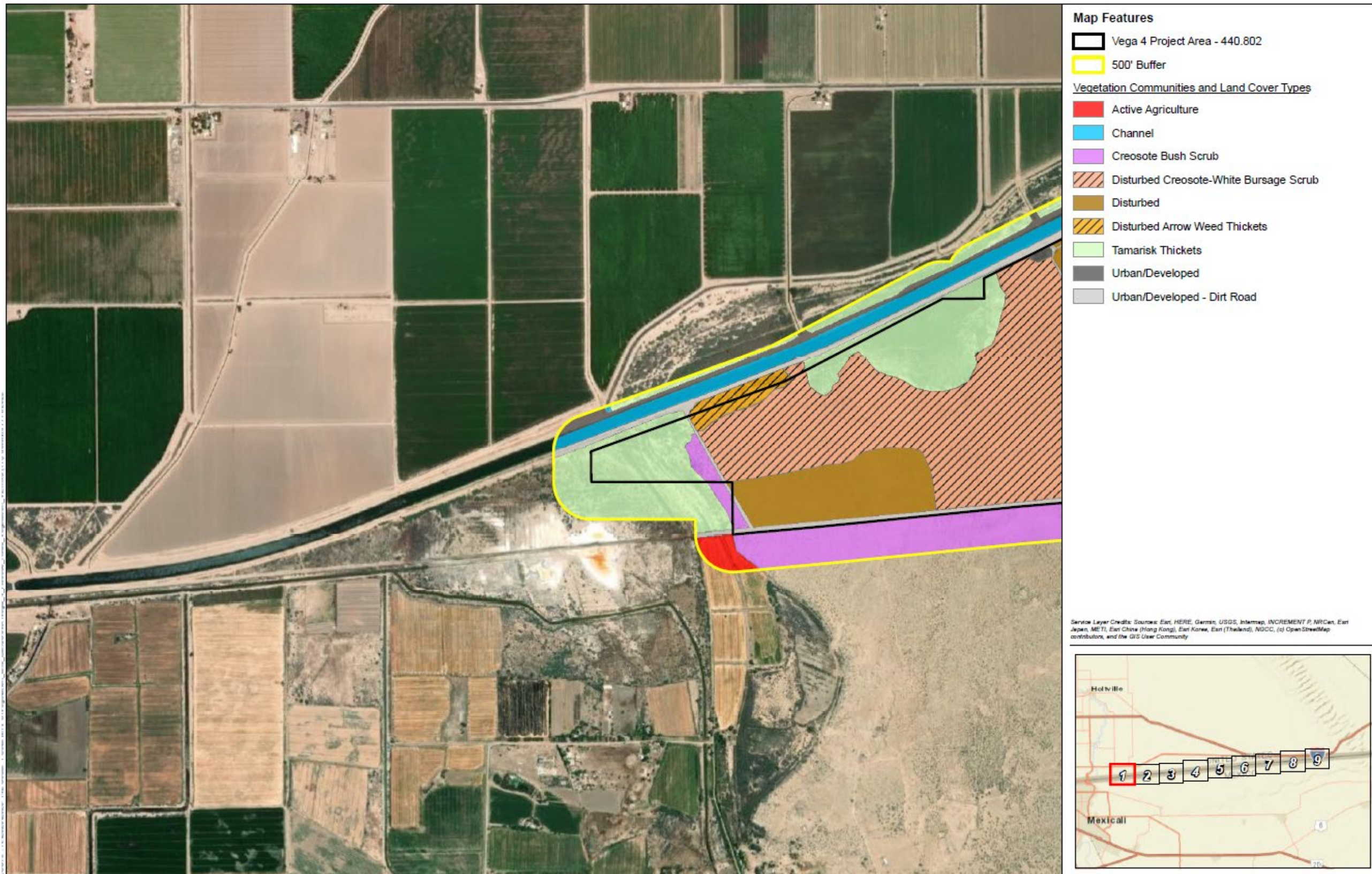
Creosote Bush Scrub (Larrea tridentata Shrubland Alliance)

Creosote bush scrub is the most characteristic vegetation of the California desert and is found on alluvial fans, bajadas, upland slopes, and washes. Creosote bush scrub is dominated by a nearly monotypic stand of creosote bush with an open canopy and an herbaceous layer of seasonal annuals and perennials. Other species that occurred on the project site included burrowbush (*Ambrosia dumosa*), apricot mallow (*Sphaeralcea ambigua*), and fanleaf crinkleemat (*Tiquilia plicata*).

Disturbed Creosote Bush – White Bursage Scrub (Disturbed Larrea tridentata – Ambrosia dumosa Shrubland Alliance)

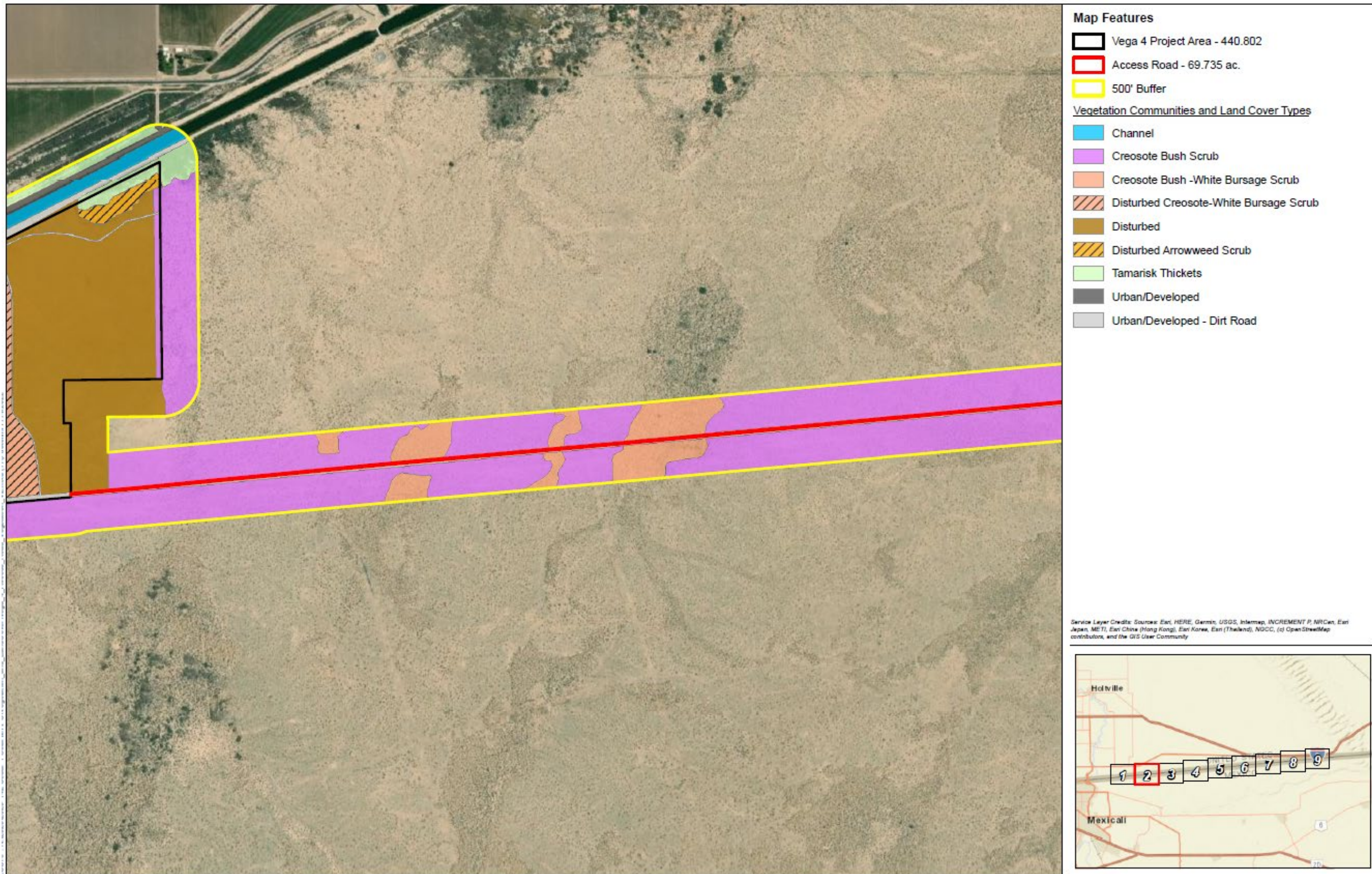
Disturbed creosote bush (i.e., white bursage scrub and white bursage scrub that has been previously altered) are co-dominant in the shrub canopy with an absent to intermittent herbaceous layer of seasonal annuals. On the project site, this vegetation cover is characterized as sparser with a high percentage of non-native plant species including common Mediterranean grass (*Schismus barbatus*) and Saharan mustard (*Brassica tournefortii*). Other plant species include dyebush (*Psoralea argemone*) and crinkleemat.

Figure 3.5-1. Vegetation Communities and Land Cover Types in the BSA (Sheet 1 of 9)



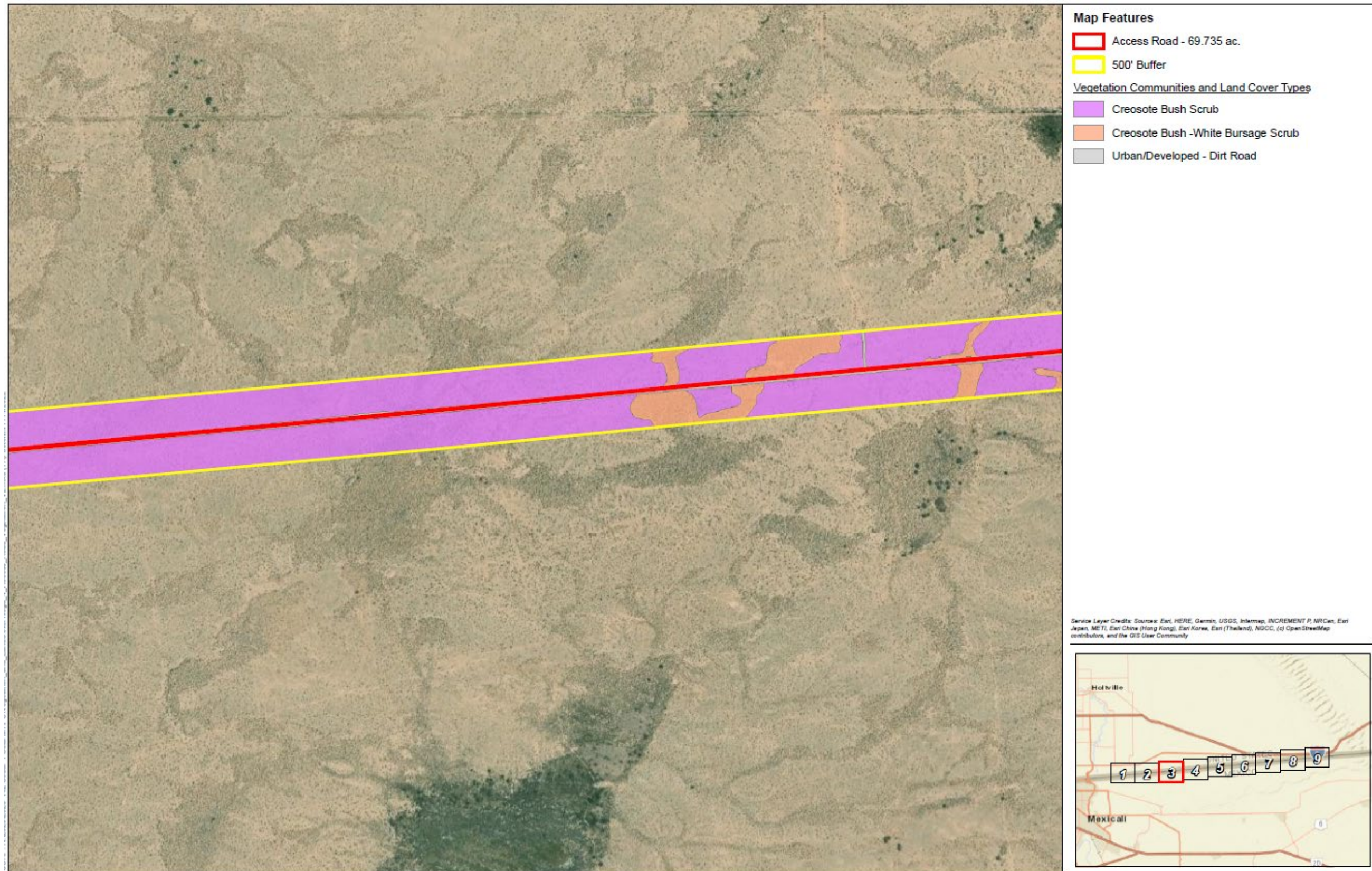
Source: Appendix D of this EIR

Figure 3.5-2. Vegetation Communities and Land Cover Types in the BSA (Sheet 2 of 9)



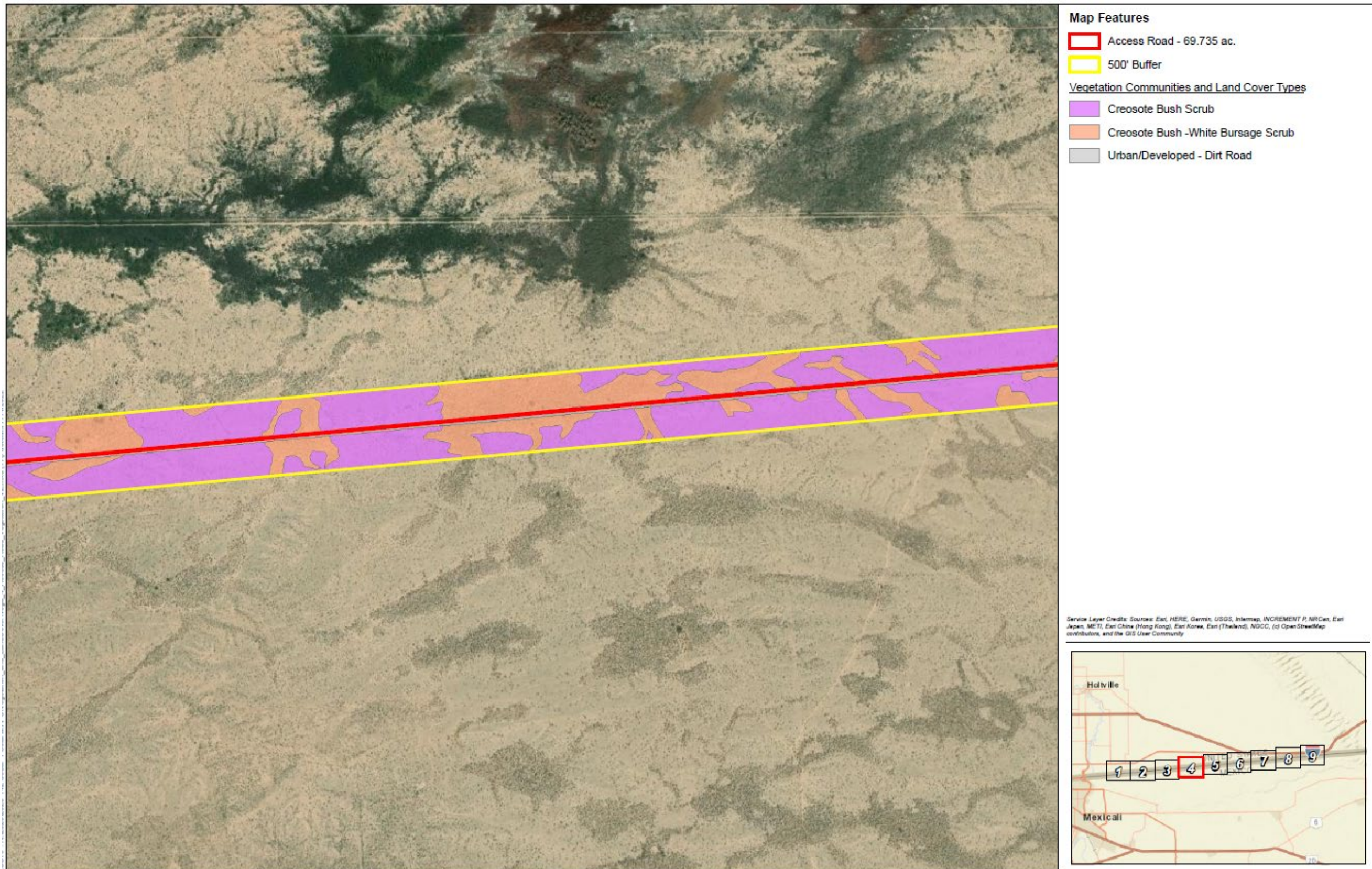
Source: Appendix D of this EIR

Figure 3.5-3. Vegetation Communities and Land Cover Types in the BSA (Sheet 3 of 9)



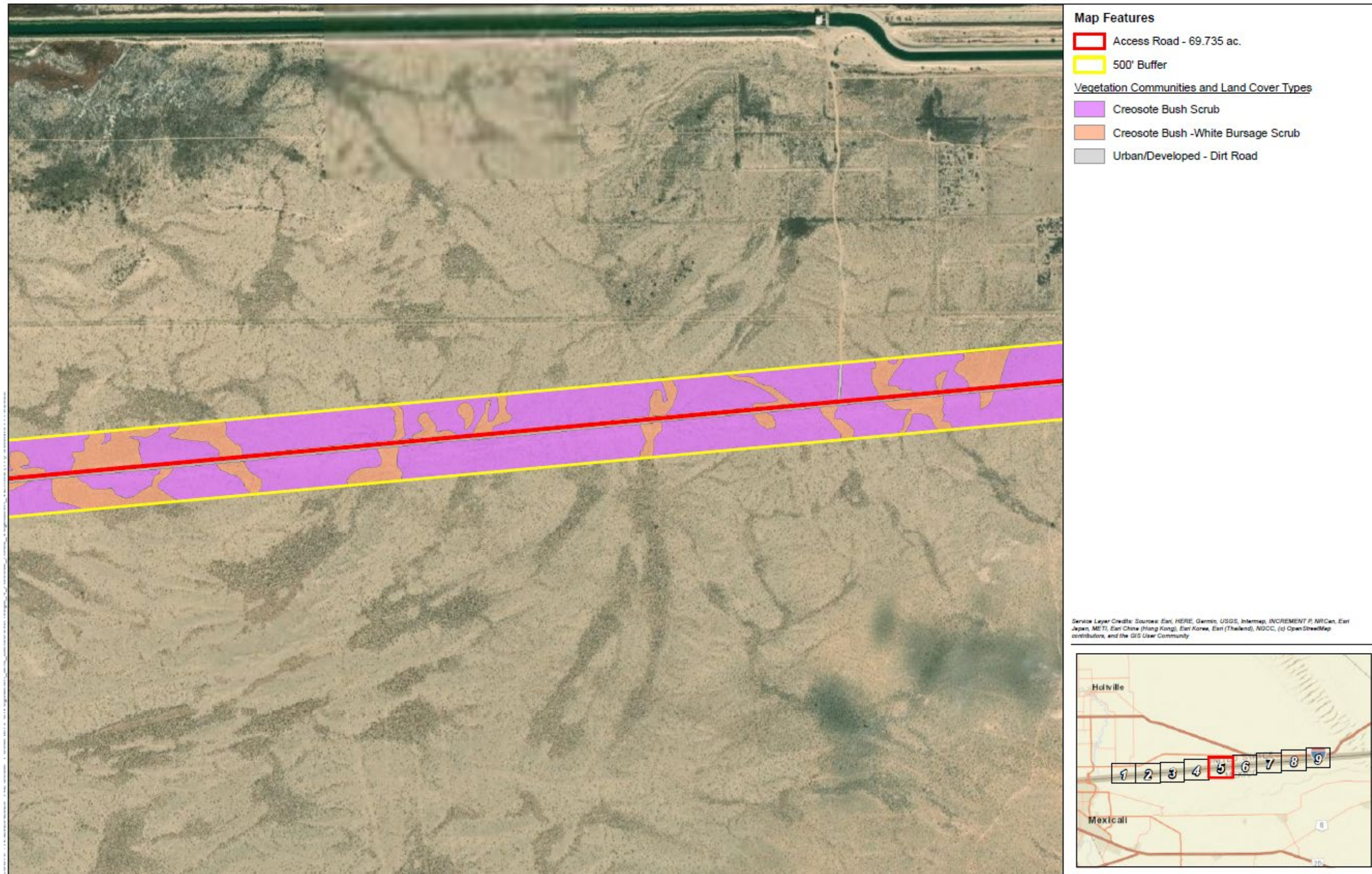
Source: Appendix D of this EIR

Figure 3.5-4. Vegetation Communities and Land Cover Types in the BSA (Sheet 4 of 9)



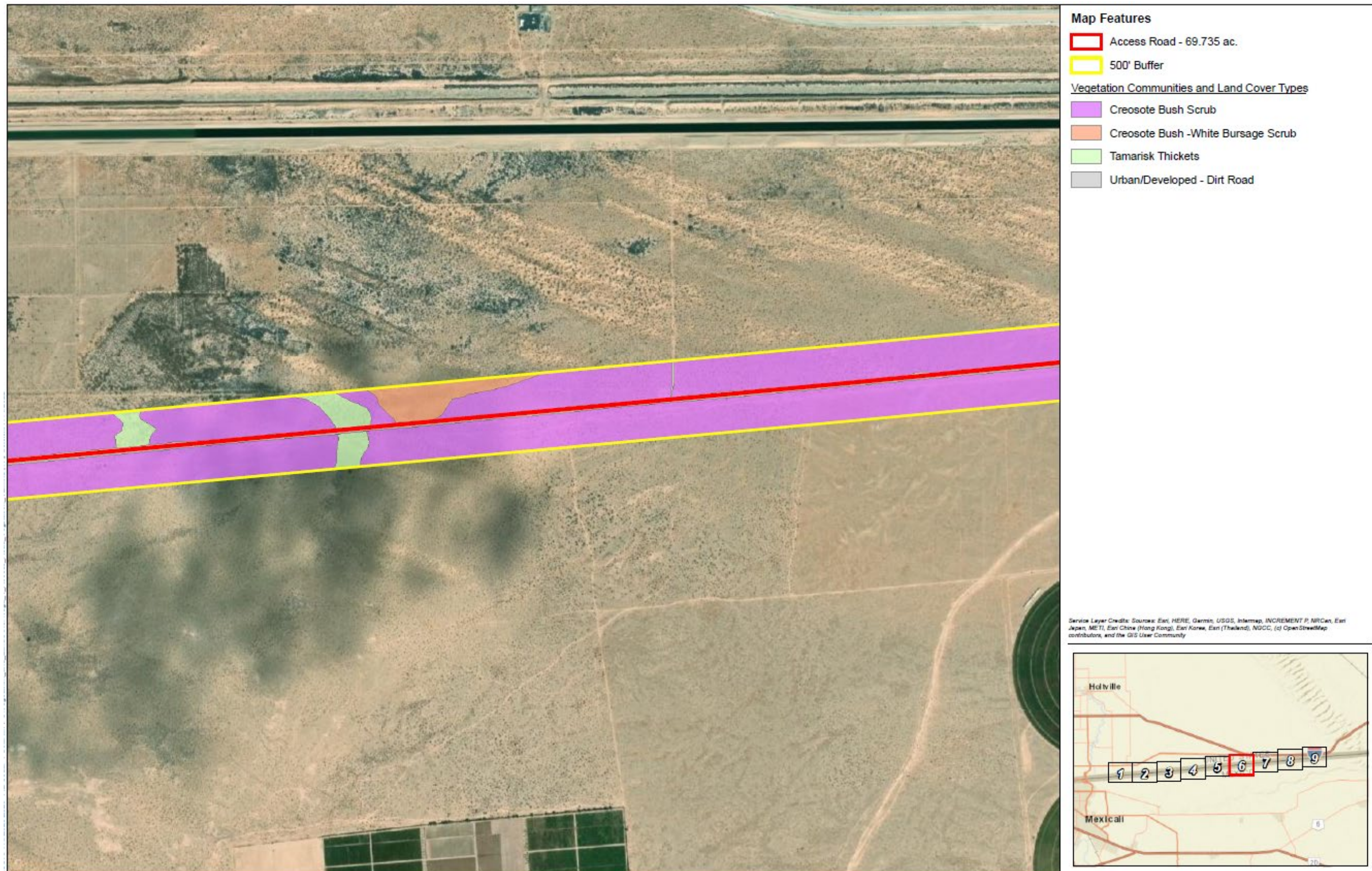
Source: Appendix D of this EIR

Figure 3.5-5. Vegetation Communities and Land Cover Types in the BSA (Sheet 5 of 9)



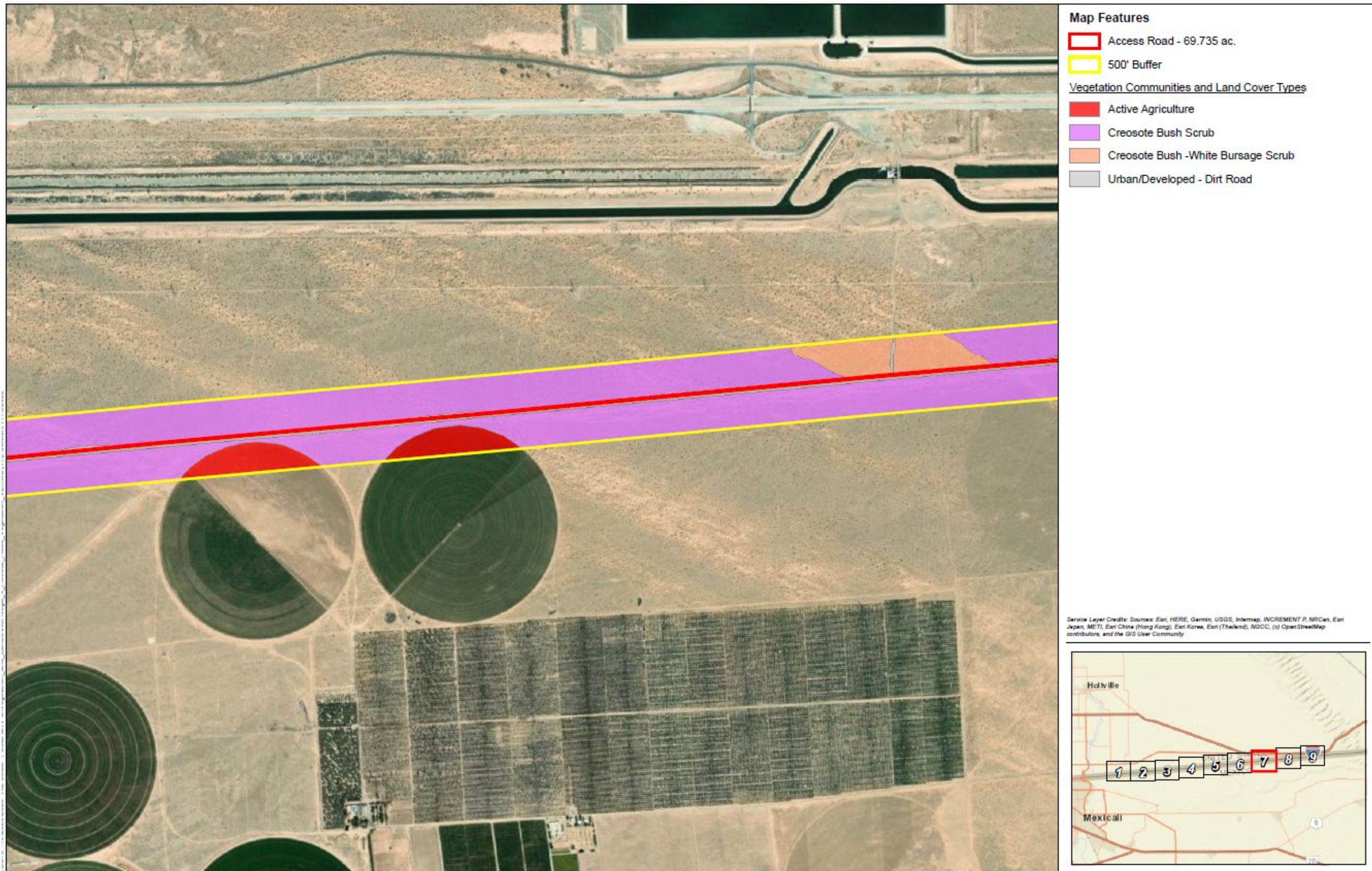
Source: Appendix D of this EIR

Figure 3.5-6. Vegetation Communities and Land Cover Types in the BSA (Sheet 6 of 9)



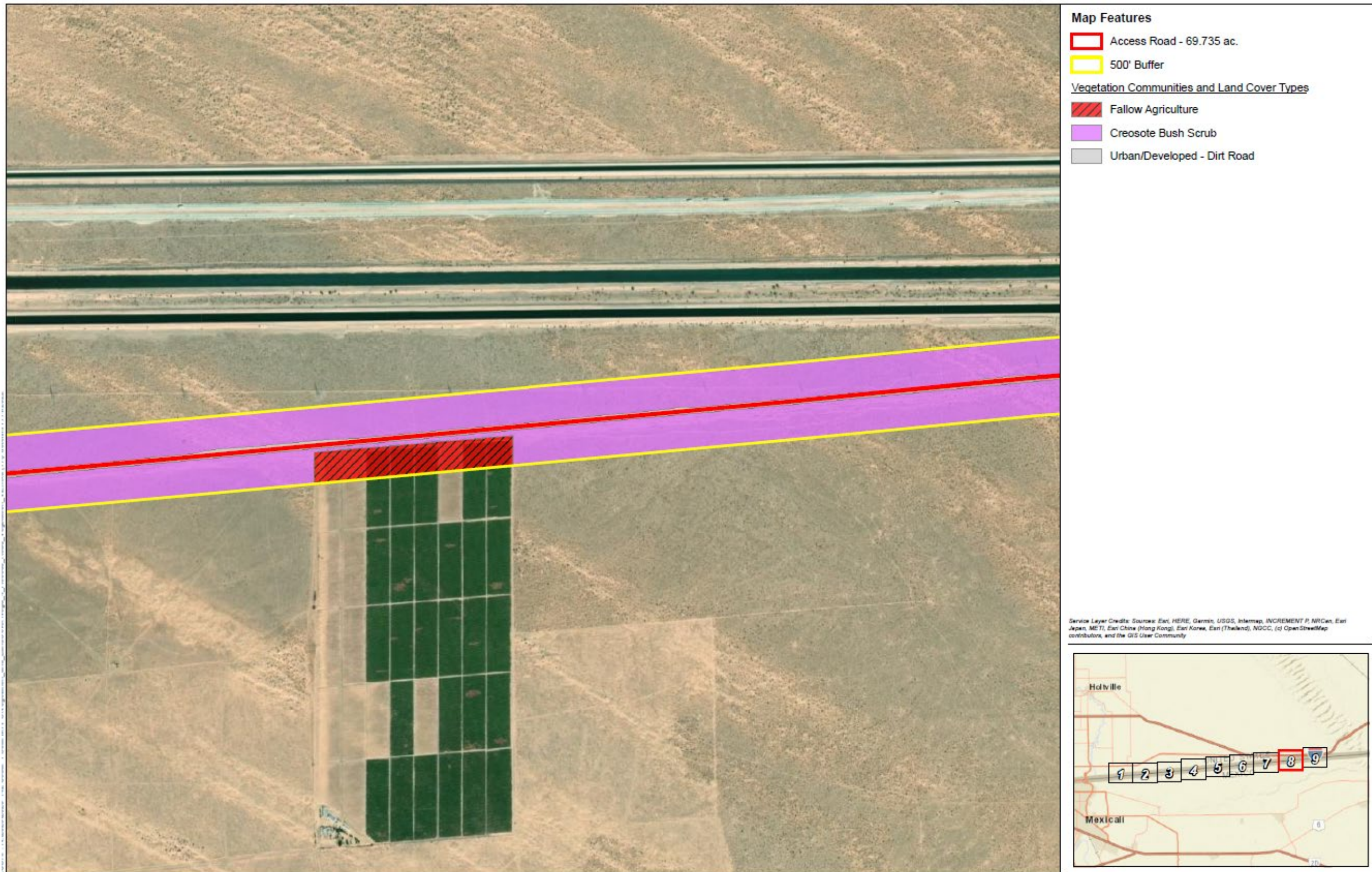
Source: Appendix D of this EIR

Figure 3.5-7. Vegetation Communities and Land Cover Types in the BSA (Sheet 7 of 9)



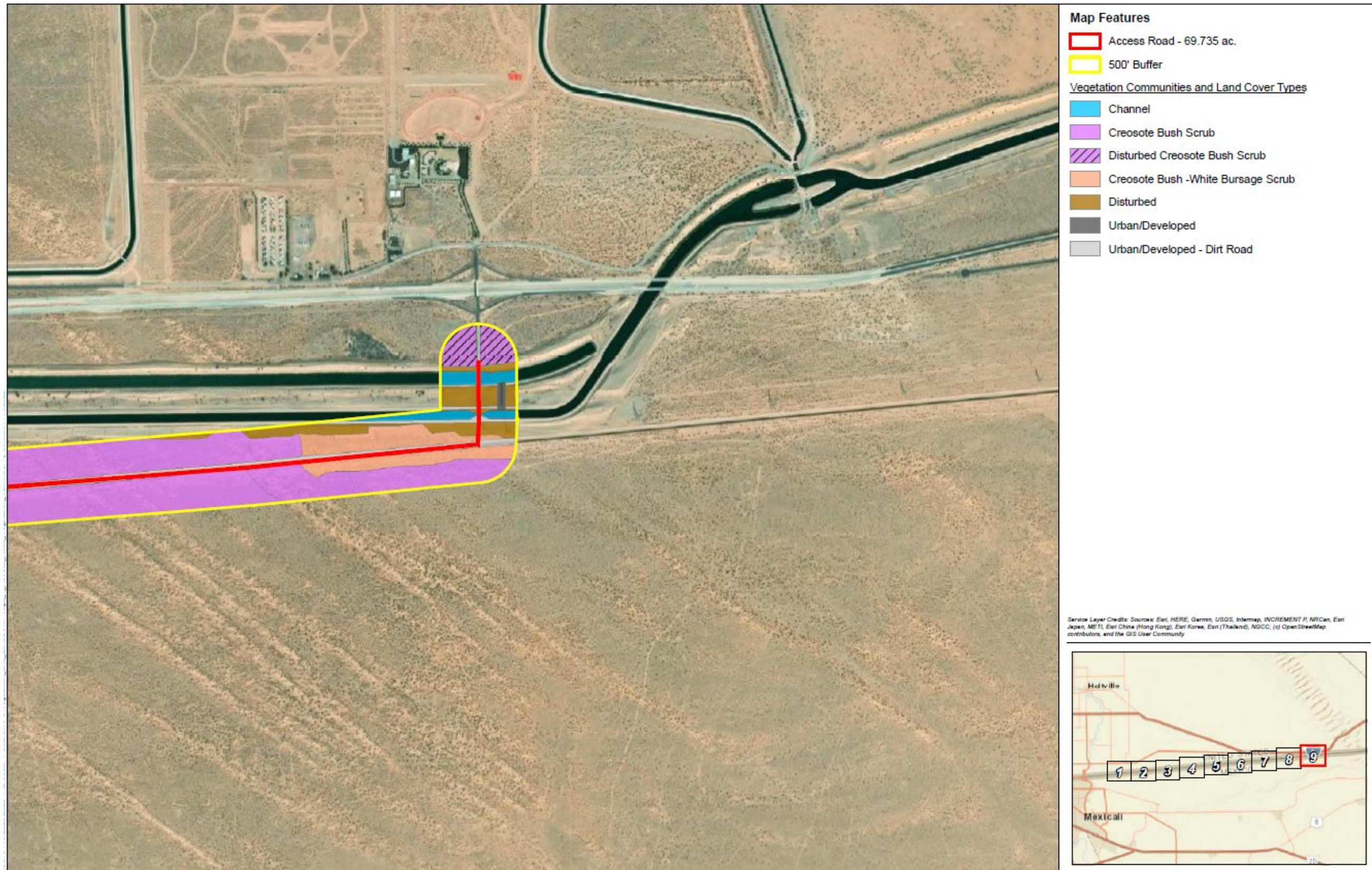
Source: Appendix D of this EIR

Figure 3.5-8. Vegetation Communities and Land Cover Types in the BSA (Sheet 8 of 9)



Source: Appendix D of this EIR

Figure 3.5-9. Vegetation Communities and Land Cover Types in the BSA (Sheet 9 of 9)



Source: Appendix D of this EIR

This page is intentionally blank.

Tamarisk Thickets (Tamarix spp. Shrubland Semi-Natural Alliance)

Tamarisk thickets are characterized by a weedy monoculture of tamarisk. This habitat is typically in ditches, washes, rivers, arroyo margins, lake margins, and other watercourses. On the project site, tamarisk and arrow weed were often co-dominant in this vegetation community. Other plant species observed included cattails (*Typha spp.*), screw bean mesquite (*Prosopis pubescens*), and willow baccharis.

Other Land Cover Types

DISTURBED

Disturbed land includes areas where the native vegetation community has been heavily influenced by human actions, such as grading, trash dumping, and OHV use, but lack development. Disturbed land is not a vegetation classification, but rather a land cover type that is not restricted by elevation. On the project site, the areas consisted primarily of bare ground and Mediterranean grass. Other plant species observed on site included dyebush and white bursage.

URBAN/DEVELOPED

Urban/Developed areas do not constitute a vegetation classification, but rather a land cover type. Areas mapped as developed have been constructed upon or otherwise physically altered to an extent that natural vegetation communities are no longer supported. There may be irrigated landscaped, ornamental species present between the hardscape. On the project site, this land cover was dominant and consisted primarily of compacted dirt roads, structures, and landscape trees including Mexican fan palm (*Washingtonia robusta*) and Mexican palo verde (*Parkinsonia aculeata*). The entirety of the access road is this land cover type.

Sensitive Natural Communities

Tamarisk thicket occurs within the project site and is considered a sensitive natural community by CDFW.

Special-Status Species

Literature Review

Prior to conducting field surveys, a literature search was conducted to identify special-status plant and animal species with potential to occur within the project BSA. The literature review resulted in 14 special-status plant and 21 special-status wildlife species that have historically been recorded in the vicinity of the project or that are highly associated with habitat that occurs on the project site. Special-status plants were evaluated for their potential to occur within the project site (project footprint) where impacts could potentially occur. Special-status wildlife species were evaluated for their potential to occur within the BSA, a broader area, where direct and indirect impacts could potentially occur. The locations of special-status species observed on the project site are shown in Figure 3.5-10 (Sheet 1 of 9) and Figure 3.5-11 (Sheet 9 of 9). There were no special-status species observed on the east side of the solar facility and the majority of the access road therefore Sheet 2 of 9 through Sheet 8 of 9 of the map set were not included in this EIR. Please see the BRTR for the full map set.

Using information from the literature review and observations in the field, a list of special-status plant and animal species that have potential to occur within the BSA was generated. For the purposes of this assessment, special-status species are defined as plants or animals that:

- have been designated as either rare, threatened, or endangered by CDFW, CNPS, or the USFWS, and/or are protected under either the federal or California ESAs;
- are candidate species being considered or proposed for listing under these same acts;
- are fully protected by the California FGC Sections 3511, 4700, 5050, or 5515; and
- are of expressed concern to resource and regulatory agencies or local jurisdictions.

Biological Reconnaissance Survey

Biological reconnaissance surveys were conducted by ECORP Consulting Inc. on September 28, 2020, April 12, 2022, and 13, 2022, by walking the entire project site to determine the existing vegetation communities and wildlife habitats on the project site. The biologists documented the plant and animal species present and the conditions within the BSA were assessed for their potential to provide habitat for special-status plant and wildlife species, including those identified in the literature review. Plant and wildlife species, including any special-status species that were observed during the survey, were recorded (see Appendix D of this EIR).

Potential for Occurrence Determinations

Special-status species reported for the region in the literature review or for which suitable habitat occurs on the BSA were assessed for their potential to occur based on the following guidelines:

Present: The species was observed onsite during a site visit or focused survey.

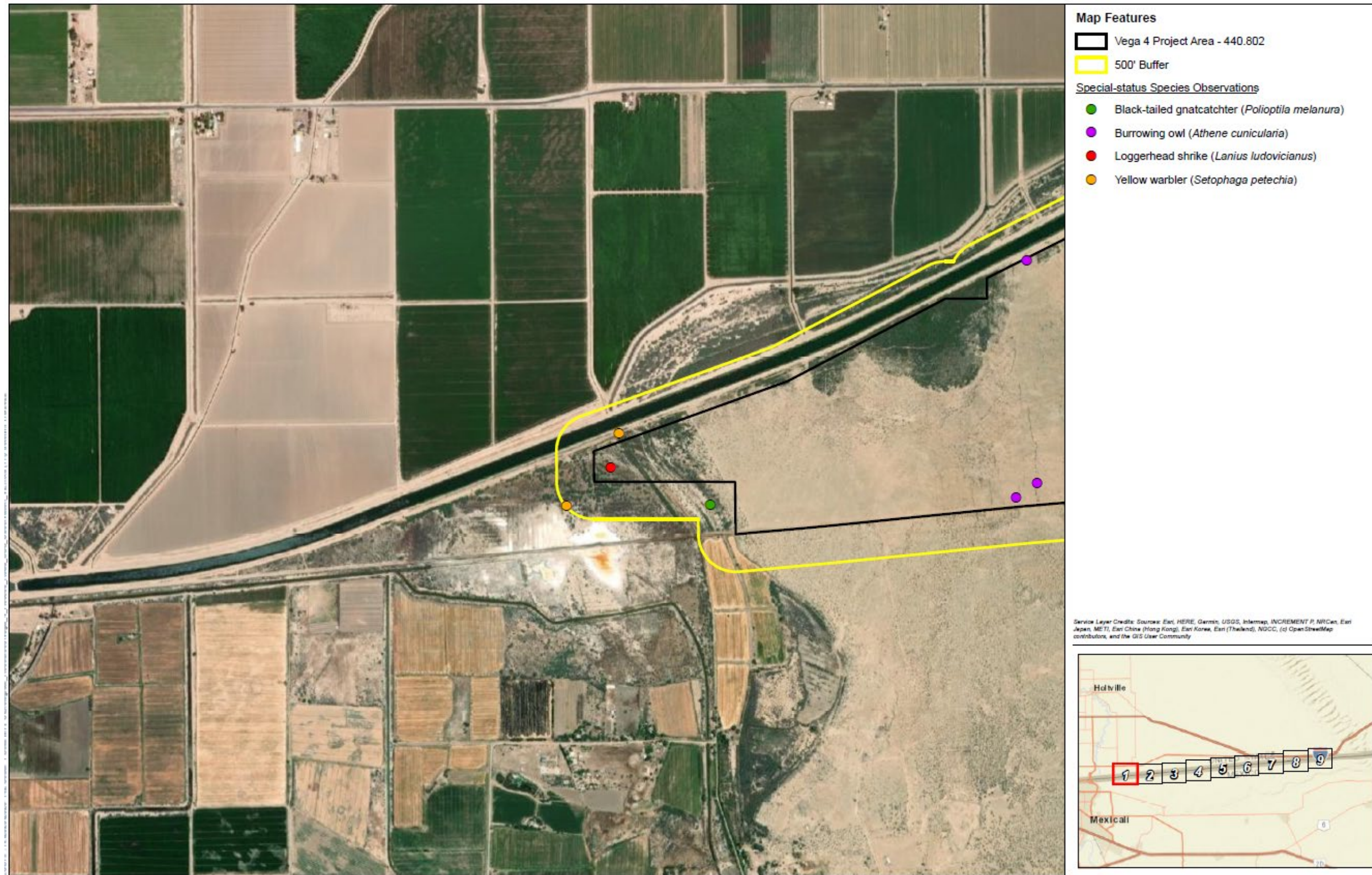
High Potential to Occur: Habitat (including soils and elevation factors) for the species occurs within the BSA and a known occurrence has recently been recorded (within the last 20 years) within five miles of the area.

Moderate Potential to Occur: Habitat (including soils and elevation factors) for the species occurs within the BSA and a documented observation occurs within the database search, but not within five miles of the area; a historic documented observation (more than 20 years old) was recorded within five miles of the BSA; or a recently documented observation occurs within five miles of the area and marginal or limited amounts of habitat occurs in the project site.

Low Potential to Occur: Limited or marginal habitat for the species occurs within the BSA and a recently documented observation occurs within the database search, but not within five miles of the area; a historic documented observation (more than 20 years old) was recorded within five miles of the BSA; or suitable habitat strongly associated with the species occurs on site, but no records or only historic records were found within the database search.

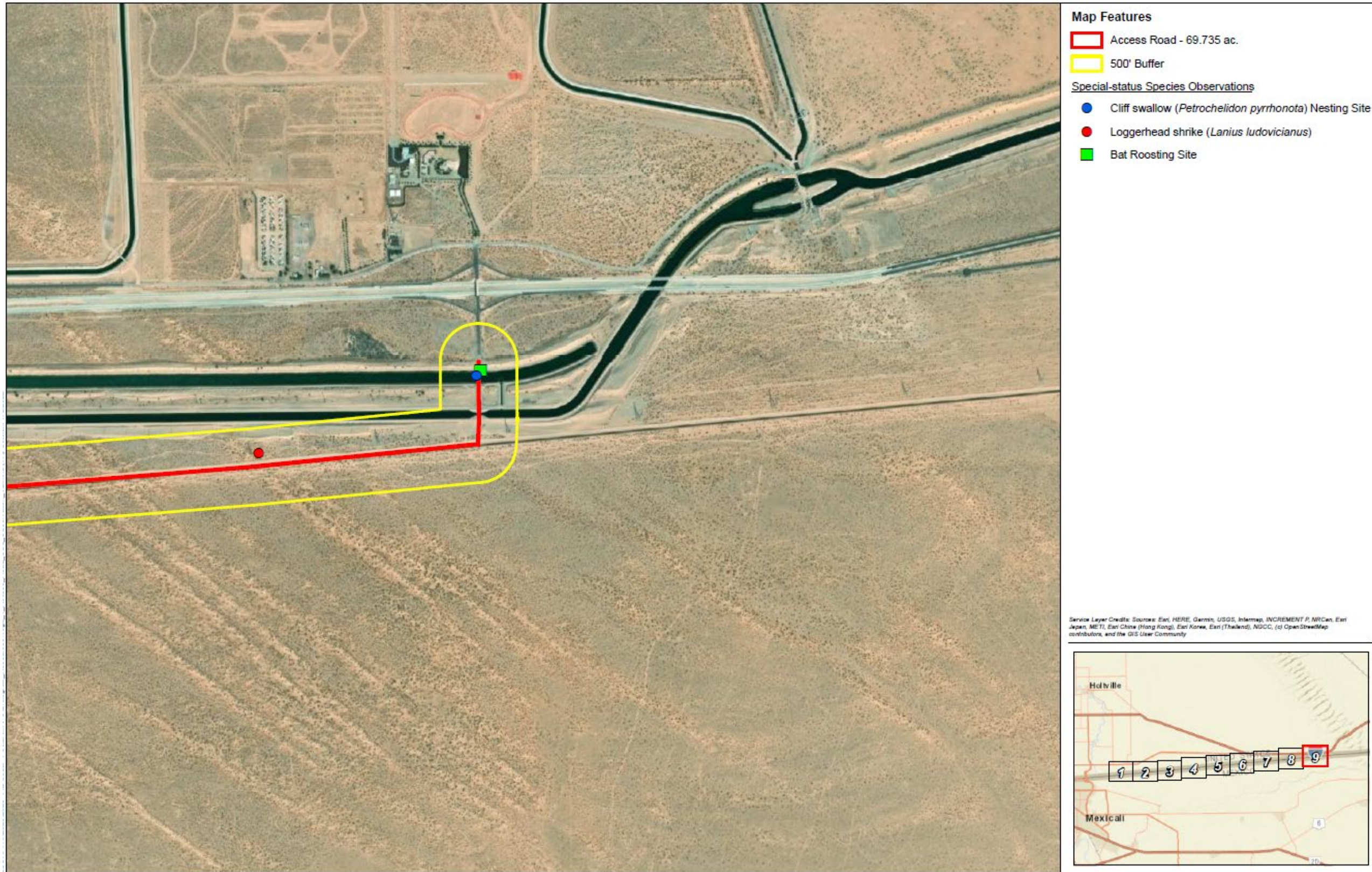
Presumed Absent: Species was not observed during a site visit or focused surveys conducted in accordance with protocol guidelines at an appropriate time for identification; habitat (including soils and elevation factors) does not exist on site; or the known geographic range of the species does not include the BSA.

Figure 3.5-10. Special-Status Species Observed On Site (Sheet 1 of 2)



Source: Appendix D of this EIR

Figure 3.5-11. Special-Status Species Observed On Site (Sheet 2 of 2)



Source: Appendix D of this EIR

Plant Species

PRESENT/OBSERVED

No special-status plant species were observed within the project site during the biological reconnaissance survey.

HIGH POTENTIAL TO OCCUR

No special-status plant species were determined as having a high potential to occur within the project site.

MODERATE POTENTIAL TO OCCUR

Due to the presence of suitable habitat and several known recent occurrences within five miles of the project site, the following species were determined to have moderate potential to occur:

- Abrams' spurge (*Euphorbia abramsiana*) is a CNPS Rare Plant Rank (CRPR) 2B.2¹ plant species. This species is known to occur at elevations between 50 and 100 meters (164 and 328 feet) and blooms between September and November. Abrams' spurge is known to occur in creosote scrub habitat within sandy flats including playas, fields, disturbed areas, and washes. One historic CNDDDB record was located approximately three miles northwest of the site near the Alamo River. Potential habitat occurs on the project site for this species in the disturbed creosote bush scrub habitat and the disturbed creosote bush – white bursage scrub habitat.
- Wiggins' croton (*Croton wigginsii*) is a CRPR 2B.2 plant species. This species is known to occur at elevations between 50 and 100 meters (164 and 328 feet) and blooms between March and May. Wiggins' croton is known to occur in sandy Sonoran desert scrub habitat. Two historic CNDDDB records were recorded with the closest being from 1993 located approximately 0.92 miles east of the Project Area. Potential habitat occurs within Project Area for this species in the sandy, creosote bush scrub and the disturbed creosote bush – white bursage scrub habitats.
- Sand food (*Pholisma sonorae*) is a CRPR 1B.2 plant species. Sand food is known to occur at elevations between sea level and 200 meters (sea level and 656 feet) and blooms between April and June. It is known to occur in sandy Sonoran desert scrub habitat. One historic CNDDDB record from 1954 was recorded approximately 0.5 mile north of the Project Area. Potential habitat occurs within the Project Area for this species in the sandy, creosote bush scrub and the disturbed creosote bush – white bursage scrub habitats.

LOW POTENTIAL TO OCCUR

The following species were found to have a low potential to occur on the project site because of limited habitat for the species on the site:

- Watson's amaranth (*Amaranthus watsonii*), CRPR 4.3
- Peirson's milk-vetch (*Astragalus magdalenae* var. *peirsonii*), CRPR 1B.2
- gravel milk-vetch (*Astragalus sabulonum*), CRPR 2B.2

¹ CNPS Rare Plant Rank: 2B = Plants rare, threatened, or endangered in California, but more common elsewhere; .2 Moderately threatened in California (20-80 percent occurrences threatened / moderate degree and immediacy of threat)

- Algodones Dunes sunflower (*Helianthus niveus* ssp. *Tephrodes*), state-listed endangered and CRPR1B.2
- California satintail (*Imperfecta brevifolia*), CRPR 2B.1
- ribbed cryptantha (*Johnstonella costata*), CRPR 4.3
- winged cryptantha (*Johnstonella holoptera*), CRPR 4.3
- hairy stickleaf (*Mentzelia hirsutissima*), CRPR 4.3
- Darlington's blazing star (*Mentzelia puberula*), CRPR 2B.2
- Slender cottonheads (*Nemacaulis denudata* var. *gracilis*), CRPR 2B.2
- Giant Spanish-needle (*Palafoxia arida* var. *gigantea*), CRPR 1B.3

Wildlife Species

The literature search documented 21 special-status wildlife species in the vicinity of the project site, two of which are federally and/or State-listed. Of the 21 special-status wildlife species identified in the literature review, 5 were present within the project site, 2 were found to have a high potential to occur, 7 were found to have a moderate potential to occur and 3 were found to have a low potential to occur. The remaining 3 species are presumed absent from the project site due to lack of suitable habitat on the site: Gila woodpecker (*Melanerpes uropygialis*), western mastiff bat (*Eumops perotis* ssp. *californicus*), and big free-tailed bat (*Nyctinomops macrotis*).

WILDLIFE SPECIES PRESENT/OBSERVED

The following species were observed on the site during the biological reconnaissance survey:

- **Northern harrier, CDFW Species of Special Concern (SSC).** This species typically found in open habitats with dense ground cover including grasslands, agricultural fields, and marshes. Northern harriers nest on the ground, preferring wetland habitat for cover. One adult was observed scanning the landscape during the field surveys.
- **Burrowing owl, USFWS Bird of Conservation Concern (BCC), CDFW SSC, and Imperial County species of conservation focus.** Burrowing owl is typically found in dry open areas with few trees and short grasses; it is also found in vacant lots near human habitation. It uses uninhabited mammal burrows for roosts and nests, often in close proximity to California ground squirrel colonies. It primarily feeds on large insects and small mammals but will also eat birds and amphibians. Three burrowing owls were observed flushing to/from their burrows during field surveys in 2020 (see Figure 3.5-2). One burrowing owl was observed within the southern portion of the project site occupying a burrow along the berm of the access road.
- **Black-tailed gnatcatcher, CDFW watch-list (WL) Species.** This species remains in pairs all year, defending permanent territories. Black-tailed gnatcatchers prefer dry washes or desert brush with varied growth of mesquite, acacias, and paloverdes, but are also known to inhabit tamarisk scrub. A pair of black-tailed gnatcatchers was observed foraging and calling within the tamarisk thicket to the west within the buffer of the project site in 2020. This species was observed again within the same area in 2022 (Figure 3.5-10).
- **Yellow warbler, USFWS BBC and CDFW SCC.** This species prefers scrub and woodlands, particularly along waterways and wetlands. Typically, yellow warblers nest in willows, alders, and cottonwoods, but have been observed nesting in tamarisk scrub. Several adults were

observed foraging in the tamarisk scrub within the buffer to the northwest of the project site during field surveys in 2020 (see Figure 3.5-10).

- **Loggerhead shrike, USFWS BCC and CDFW SSC.** This species prefers open country with scattered shrubs and trees. They frequent agricultural fields, abandoned orchards, desert scrublands, and riparian areas. One individual was observed perching in the tamarisk thickets in the western section of the project site during field surveys in 2020 (see Figure 3.5-10). An individual was also observed perched within the creosote bush scrub habitat to the north of the access road in 2022 (see Figure 3.5-11).

HIGH POTENTIAL TO OCCUR

Although not present during field surveys, two species were found to have high potential to occur on the project site due to the presence of suitable habitat for the species on the site and because a known occurrence has been recorded within five miles of the site:

- **Flat-tailed horned lizard (*Phrynosoma mcallii*), CDFW SSC and Imperial County Species of conservation focus.** This species is most commonly found on sandy flats and valleys within desert scrub habitat with little or no windblown sand. They can also be found on salt flats and gravelly soils. The creosote bush scrub and salt flat habitats provide suitable habitat for the flat-tailed horned lizard.
- **Yuma hispid cotton rat (*Sigmodon hispidus eremicus*), CDFW SSC.** This species is generally associated with mesic habitats near drainage ditches, streams, and sloughs but also occurs in open fields or on the borders of open fields where there is dense grass habitat or agricultural fields. There is potential for this species to occur near the All-American Canal and nearby creosote bush scrub habitat. Two recent CNDDDB records occur less than one mile north of the access road for the site. This species was found in arrow weed scrub and freshwater marsh adjacent to the All-American Canal in 2007.

MODERATE POTENTIAL TO OCCUR

Although not present during field surveys, seven species were found to have moderate potential to occur on the project site because habitat (including soils and elevation factors) for the species occurs on the site:

- **Yuma Ridgway's rail (*Rallus obsoletus yumanensis*), federally listed as endangered and state listed as threatened.** The Yuma Ridgway's rail prefers freshwater marshes composed of cattails and bulrushes. There is suitable habitat for this species within the wetlands nestled within the tamarisk and arrow weed scrub.
- **California horned lark (*Eremophila alpestris ssp. actia*), CDFW WL species.** It occurs in bare, open areas dominated by low vegetation or widely scattered shrubs, including prairies, deserts, and plowed fields. It nests in a hollow on the ground. The disturbed creosote scrub habitat onsite and in the buffer zones provides potential habitat. No CNDDDB records occur within five miles of the project site.
- **Yellow-breasted chat (*Icteria virens*), CDFW SSC.** This species is commonly found in shrublands along rivers. There is potential for the yellow-breasted chat to occur within the arrow weed and tamarisk scrub in the eastern portion of the project site.
- **Pallid bat (*Antrozous pallidus*), CDFW SSC.** This species is commonly found in desert habitat and is known to roost in bridges. Potential roosting habitat for this species is present

within the Gordon Wells Road bridge that crosses over the offline storage canal, north of the All-American Canal.

- **Townsend's big-eared bat (*Corynorhinus townsendii*), CDFW SCC.** The project site is within the known range of this species and this species is known to roost in bridges. Potential roosting habitat for this species is present within the Gordon Road Wells bridge that crosses over the offline storage canal, north of the All-American Canal.
- **Western yellow bat (*Lasiurus xanthinus*), CDFW SSC.** This species is commonly found in desert habitat and is known to roost in the skirts of untrimmed palm trees. Potential roosting habitat for this species is present within the palm trees of the northeastern portion of the project site.
- **Arizona myotis (*Myotis occultus*) is a CDFW SSC.** The project site is within the known range of this species and this species is known to roost in bridges. Potential roosting habitat for this species is present within the Gordon Wells Road bridge that crosses over the offline storage canal, north of the All-American Canal.

LOW POTENTIAL TO OCCUR

Three species were found to have a low potential to occur on the project site because limited habitat for the species occurs on the site and a known occurrence has been reported in the database, but not within five miles of the site, or suitable habitat strongly associated with the species occurs on the site, but no records were found in the database search:

- southwestern willow flycatcher (*Empidonax traillii ssp. extimus*), federally listed endangered and state-listed endangered;
- Sonoran desert toad (*Incilius alvarius*), CDFW SSC; and,
- red-diamond rattlesnake (*Crotalus ruber*), CDFW SSC.

WILDLIFE SPECIES PRESUMED ABSENT

The following three species are presumed absent from the Project Area due to the lack of suitable habitat on the site:

- Gila woodpecker (*Melanerpes uropygialis*), USFWS BCC and CDFW END;
- western mastiff bat (*Eumops perotis ssp. californicus*), CDFW SSC; and
- big free-tailed bat (*Nyctinomops macrotis*), CDFW SSC.

Aquatic Resources

The *Aquatic Resources Delineation Report* identifies the aquatic resources occurring within the project site that may be regulated by the Porter-Cologne Water Quality Act, California Fish and Game Code Sections 1600 and 1602, and USACE pursuant to Sections 401 and 404 of the federal Clean Water Act (CWA).

The boundaries of aquatic resources were delineated through standard field methods (e.g., paired sample set analyses) and aerial photograph interpretation. Field data was recorded on Wetland Determination Data Forms - Arid West Region and Arid West Ordinary High Water Mark (OHWM) Datasheets (see Appendix E of this EIR). ESRI© and SUAS aerial imagery were used to assist with mapping and ground-truthing.



Where jurisdictional features were present, the extent of potential Waters of the State and CDFW-regulated streambed and top-of-bank limits were determined using the OHWM in accordance with USACE requirements and guidelines, as well as SWRCB and CDFW delineation guidance (see Appendix E for details). Streambed widths were based on evidence of OHWM as observed during the field survey. In addition, each of the drainages were evaluated for the presence or absence of sediment deposits, litter/debris, water stains, soil shelving, and/or exposed roots indicating active hydrology within the channel. Streambed widths and other lateral limits of jurisdiction were calculated and recorded. The extent of associated riparian habitat was based on the extent of the canopy of the riparian community within or directly adjacent to the feature. Bank-to-bank width measures were also recorded and used as a measure of CDFW jurisdictional boundary where features lacked riparian vegetation.

A total of 11 resources summing to 2,940.82 acres of aquatic resources have been mapped within the project site. These results are subject to agency verification. Aquatic resources are summarized in Table 3.5-2 and depicted on Figure 3.5-12 through Figure 3.5-17. There were no aquatic resources mapped on the majority of the access road therefore those map sheets were not included in this EIR. Please see the *Aquatic Resources Delineation Report* for the full map set.

Features identified as an aquatic resource had wetland indicators present and/or physical evidence of flow including OHWM, defined bed and bank, presence of a clear and natural line impressed on the bank, the presence or absence of sediment deposits, litter/debris, and/or exposed roots indicating active hydrology within the channel. Associated riparian habitat identified within the project site consisted of hydrophytic vegetation and hydrological indicators but lacked hydric soil indicators.

Table 3.5-2. Aquatic Resources and Associated Vegetation on the Project Site

Resource Name ^a	Aquatic Resources Classification		OHWM/Wetland Presence Summary	Dominant Vegetation	Resource Size (acre)
	Cowardin ^b	Location (latitude/longitude)			
ED-1	R6	32.67954541/ -115.31681051	Runoff and precipitation; OHWM indicators: defined bed and bank and vegetation matted down, bent, or absent.	Tamarisk Thickets	701.55
ED-2	R6	32.67977819/ -115.31686094	Runoff and precipitation; OHWM indicators: defined bed and bank and vegetation matted down, bent, or absent.	Tamarisk Thickets	717.55
ED-3	R6	32.67983223/ -115.31627266	Runoff and precipitation; OHWM indicators: defined bed and bank.	Tamarisk Thickets	806.88
FSW-1	PSS1C	32.67960789/ -115.31829880	Wetland criteria met: hydrophytic vegetation present, hydric soils present,	Arrow Weed Thickets	N/A

Table 3.5-2. Aquatic Resources and Associated Vegetation on the Project Site

Resource Name ^a	Aquatic Resources Classification		OHWM/Wetland Presence Summary	Dominant Vegetation	Resource Size (acre)
	Cowardin ^b	Location (latitude/longitude)			
			and hydrological indicators present.		
FSW-2	PSS1C	32.68345488/ -115.31168036	Wetland criteria met: hydrophytic vegetation present, hydric soils present, and hydrological indicators present.	Tamarisk Thickets	N/A
FSW-3	PSS1C	32.68496608/ -115.30521625	Wetland criteria met: hydrophytic vegetation present, hydric soils present, and hydrological indicators present.	Tamarisk Thickets	N/A
PD-1	R2AB3H	32.67989722/ -115.31746236	Wetland criteria met within the channel with OHWM indicators; bisects wetland riparian habitat.	Tamarisk Thickets	664.88
Unassociated Riparian Habitat	N/A	32.68384969, -115.30666666	N/A	Arrow Weed and Tamarisk Thickets	N/A
Unassociated Disturbed Riparian Habitat	N/A	32.69004265 -115.29438590	N/A	Disturbed Arrow Weed Thickets	N/A
All American Canal ^c	R2UBHx	32.70397136 -114.95717380	N/A	Unvegetated	24.99
Off Line Storage ^c	R2UBHx	32.70532216 -114.95718630	N/A	Unvegetated	24.97
Total					2940.82

Source: Appendix E of this EIR

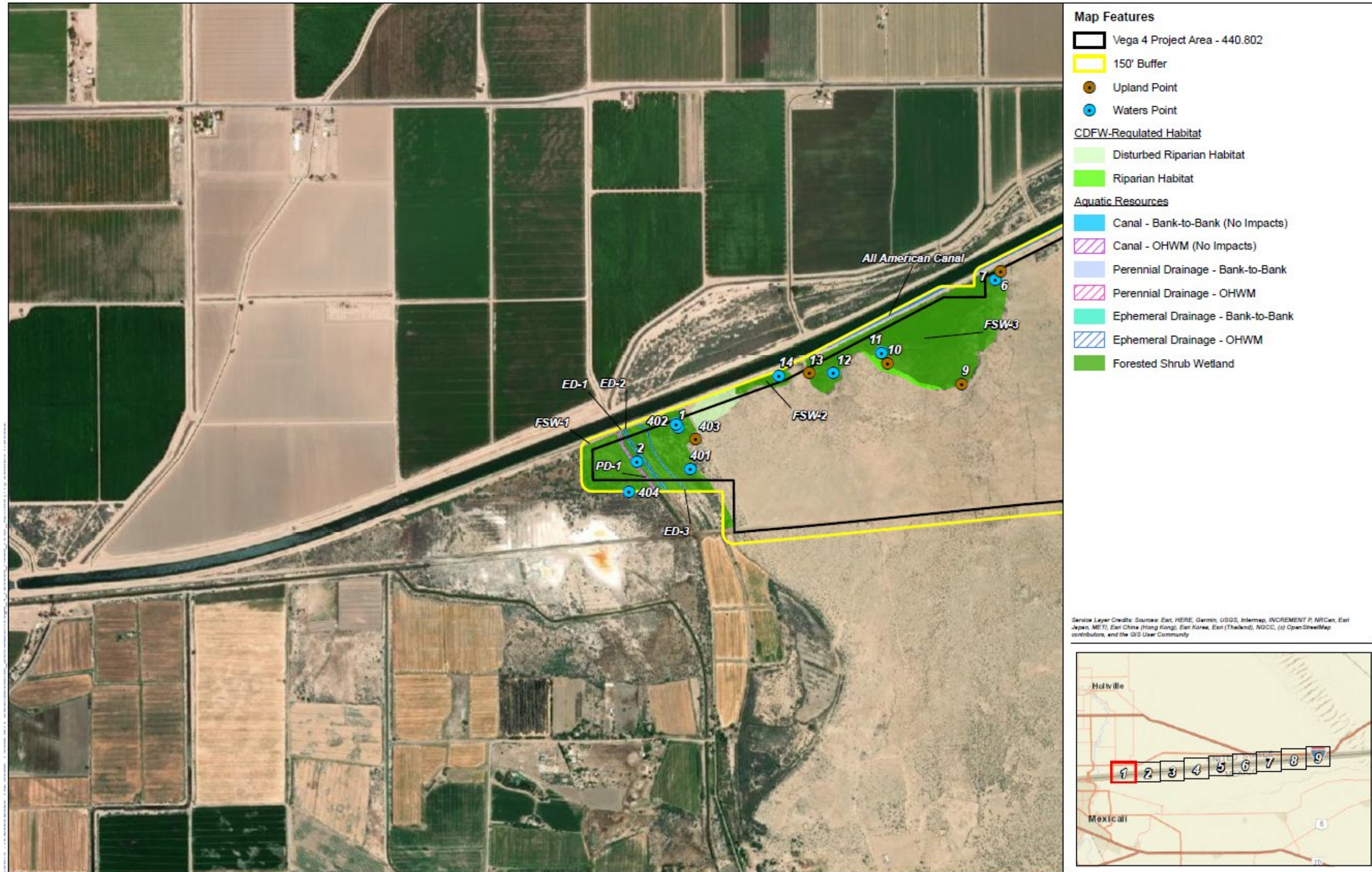
Notes:

a ED= Ephemeral Drainage, FEW= Freshwater Emergent Wetland, FSW= Freshwater Forested/Shrub Wetland, PD= Perennial Drainage.

b Cowardin Codes: (R6) Riverine, ephemeral; (PEM1C) Freshwater Emergent Wetland; (PSS1C) Freshwater Forested/Shrub Wetland; (R2AB3H) Riverine, lower perennial, aquatic bed, rooted vascular.

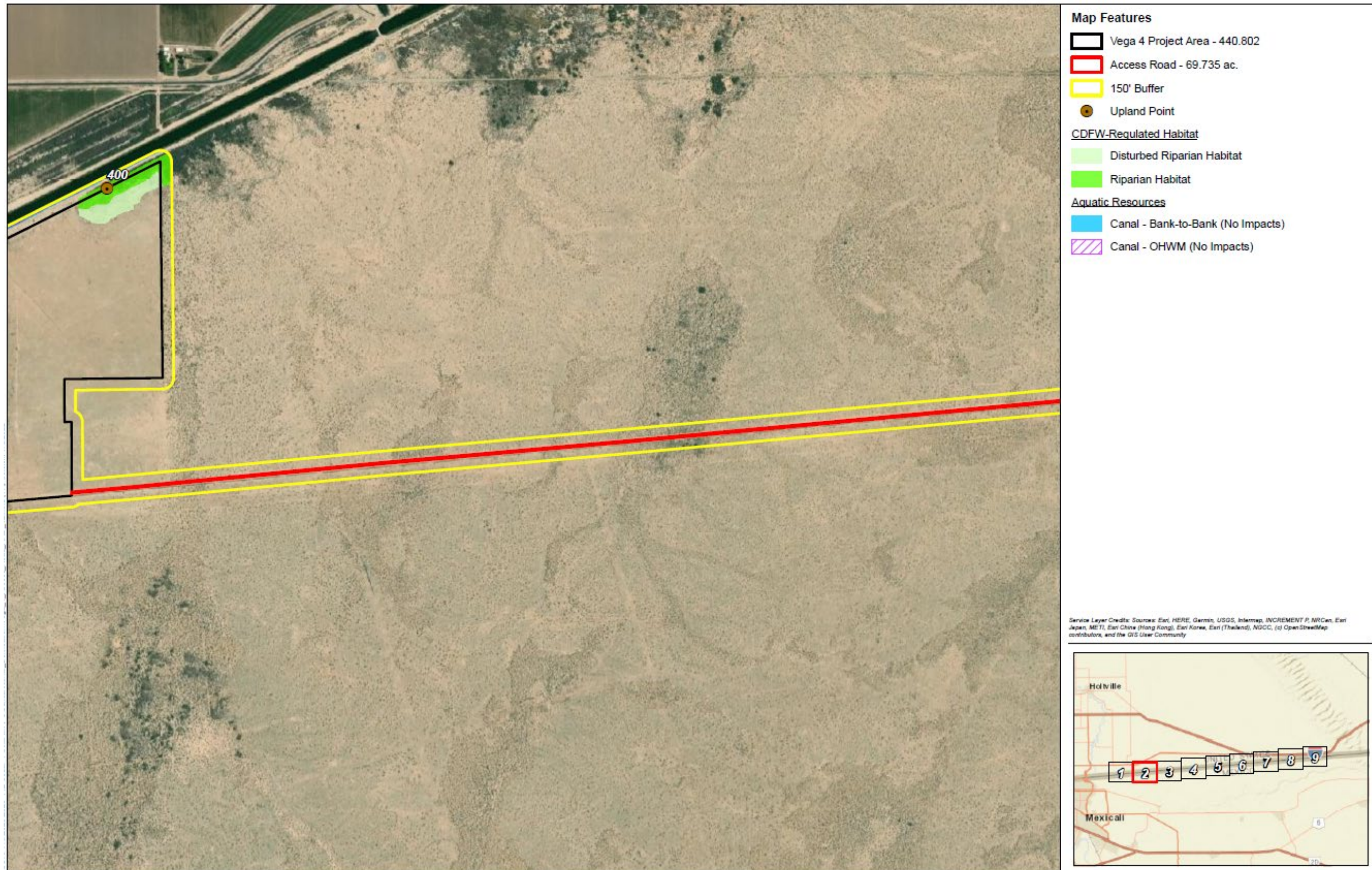
c Impacts to these features are not expected to occur, as features flow beneath access road entry bridge.

Figure 3.5-12. Potential Jurisdictional Waters (Sheet 1 of 6)



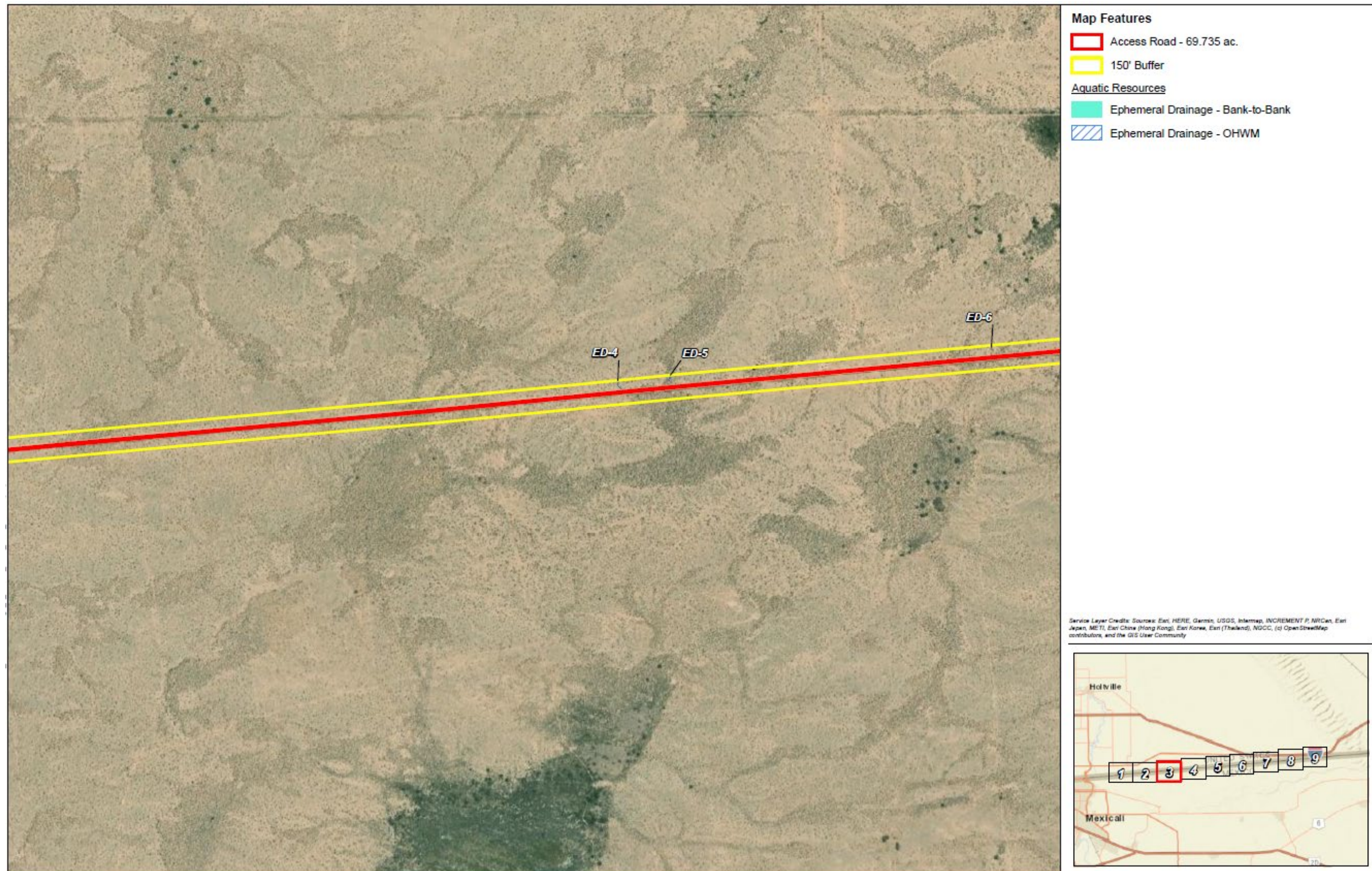
Source: Appendix E of this EIR

Figure 3.5-13. Potential Jurisdictional Waters (Sheet 2 of 6)



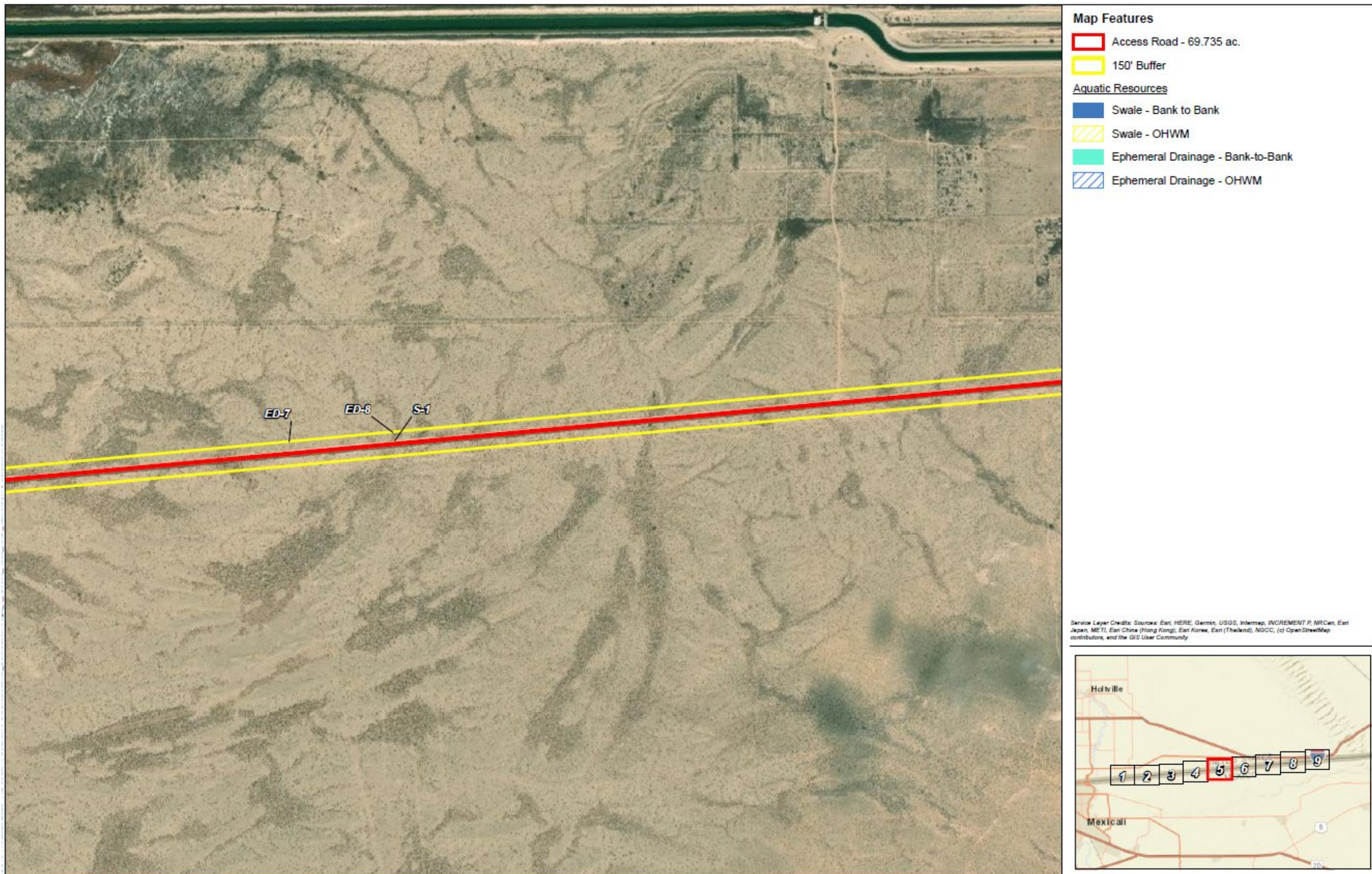
Source: Appendix E of this EIR

Figure 3.5-14. Potential Jurisdictional Waters (Sheet 3 of 6)



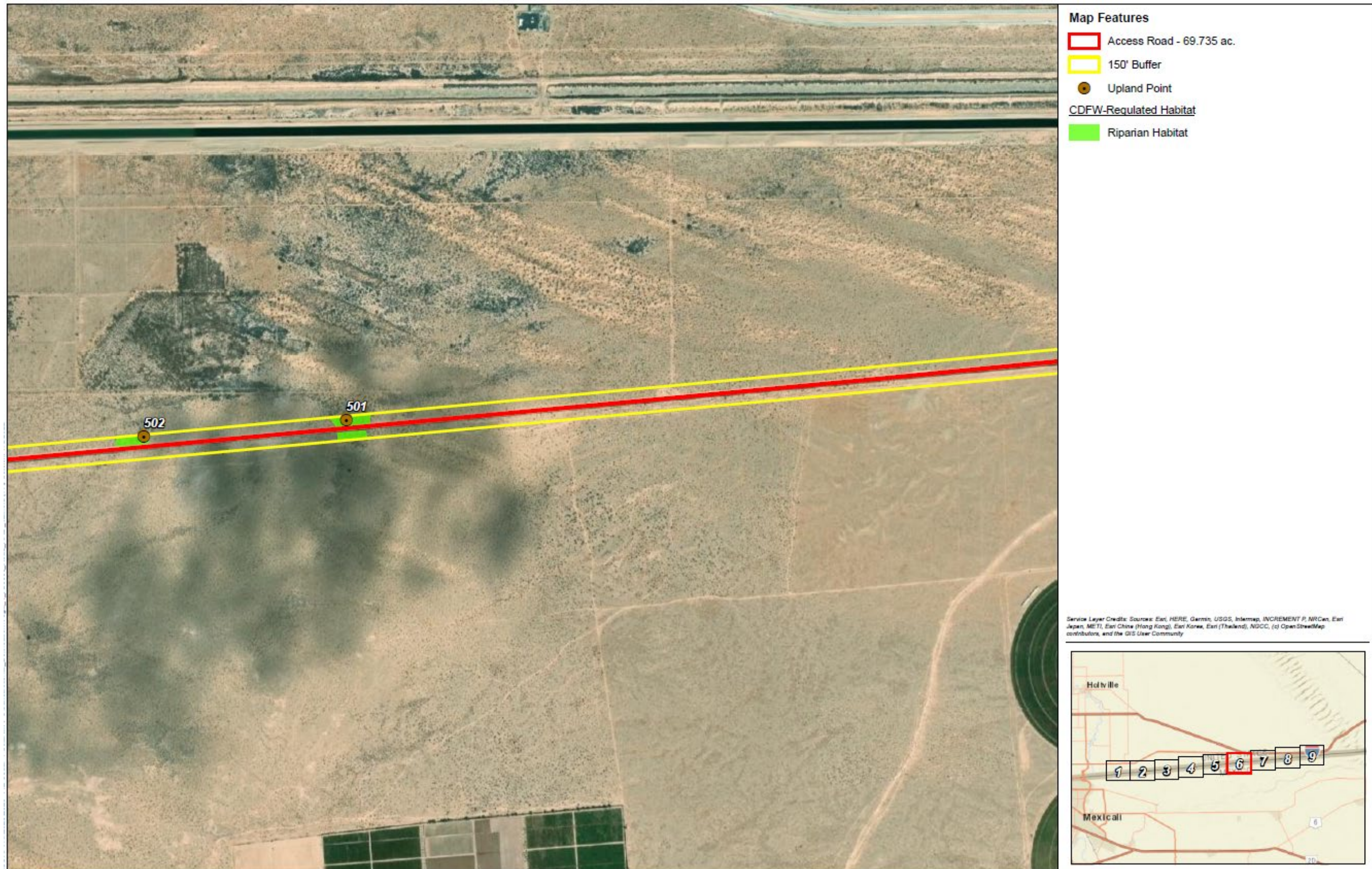
Source: Appendix E of this EIR

Figure 3.5-15. Potential Jurisdictional Waters (Sheet 4 of 6)



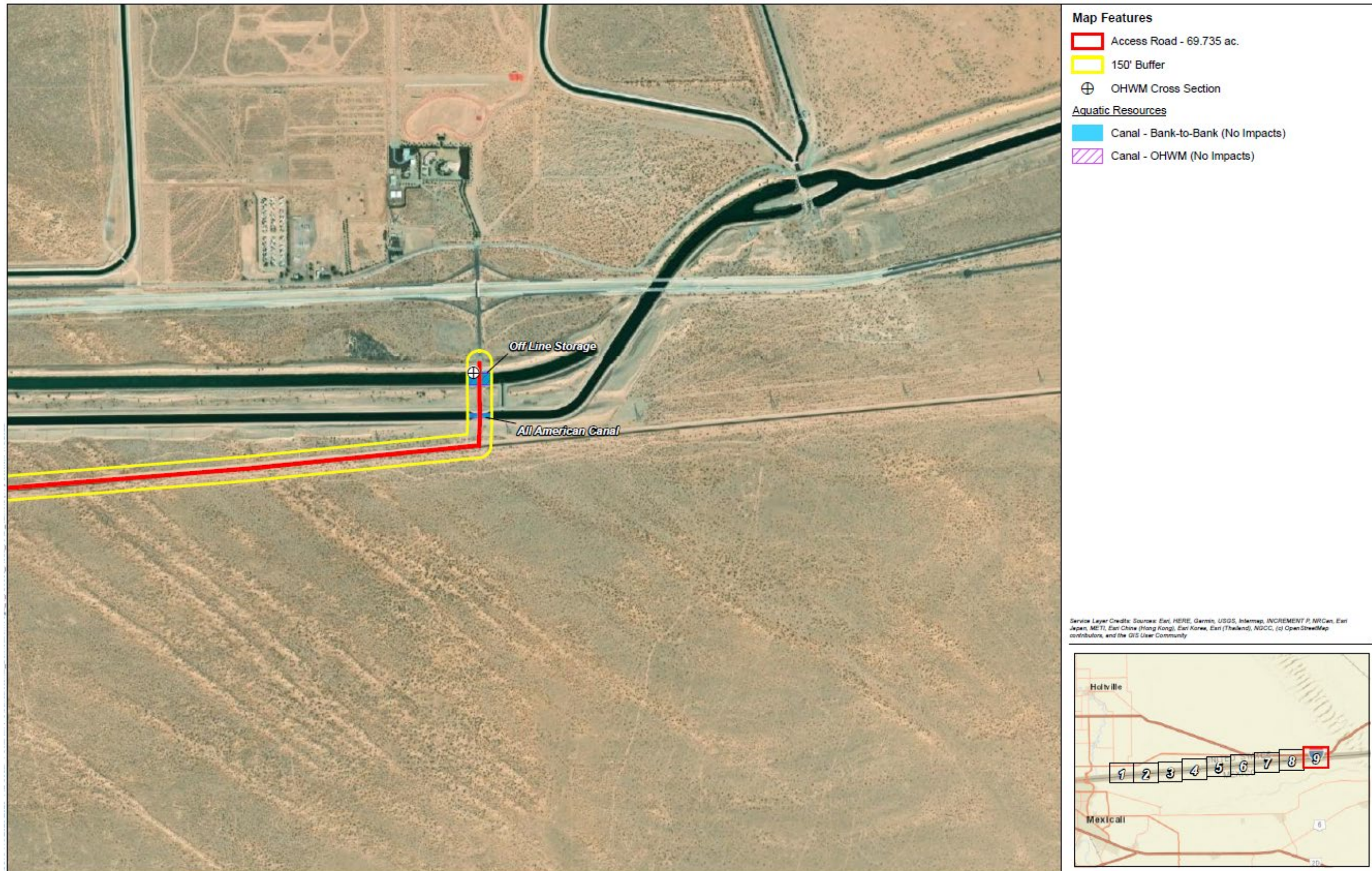
Source: Appendix E of this EIR

Figure 3.5-16. Potential Jurisdictional Waters (Sheet 5 of 6)



Source: Appendix E of this EIR

Figure 3.5-17. Potential Jurisdictional Waters (Sheet 6 of 6)



Source: Appendix E of this EIR

Wetlands

FRESHWATER FORESTED/SHRUB WETLAND

Freshwater forested/shrub wetlands (FSW) are dominated by woody vegetation such as true shrubs, young trees (saplings), and trees or shrubs that are stunted due to environmental conditions. They are seasonally flooded: therefore, surface water is present for extended periods, particularly in the early growing season, but is absent by the end of the growing season in most years. The water table can be variable after a flooding event, and ranges from saturation at the ground surface to a water table well below the ground surface. As shown in Table 3.5-2 and Figure 3.5-12, there are three FSW within the project site (FSW-1, FSW-2, and FSW-3).

Other Aquatic Resources

PERENNIAL DRAINAGE

Perennial drainages (PD) are linear features that exhibit a bed and bank and an OHWM. These features typically contain surface water flowing continuously year-round. As shown in Table 3.5-2 and Figure 3.5-12, there is one PD within the project site. OHWM indicators observed for the perennial drainage (PD-1) that occurs within the western portion of the project site included defined bed and bank, change in vegetation species, change in vegetation cover, and natural line impressed in bank. The existing hydrology of PD-1 supports emergent wetland habitat within the channel.

EPHEMERAL DRAINAGE

Ephemeral drainages (ED) are linear features that exhibit a bed and bank and an OHWM. These features typically convey runoff for short periods of time, during and immediately following rain events, and are not influenced by groundwater sources at any time during the year. As shown in Table 3.5-2 and Figure 3.5-12, the project site contains three ephemeral drainages within the western portion of the site (ED-1, ED-2, and ED-3). These manmade drainages convey flow through the project site and into a freshwater emergent wetland located off-site to the west.

MANMADE FEATURES

A total of two main canals managed by IID, the All-American Canal and the associated Off-line Storage Canal, were identified within the access road portion of the Study Area and are assumed to flow perennially. Both canals bisect the easternmost portion of the Study Area (Figure 3.5-17). The concrete-lined All-American Canal is maintained by IID in order to be free of vegetation for water conveyance efficiency. The Off-line Storage Canal is natural-bottomed, and flow and water levels are maintained by IID. The All-American Canal brings water from the Colorado River at the Imperial Dam and supplies it to the Imperial Valley through smaller lateral canals, all of which ultimately drain to the Salton Sea (Appendix E). Because these canals flow underneath the access road entry bridge, no impacts are expected to occur to either canal.

Wildlife Movement Corridors, Linkages, and Significant Ecological Areas

The concept of habitat corridors addresses the linkage between large blocks of habitat that allow the safe movement of mammals and other wildlife species from one habitat area to another. The definition of a corridor is varied, but corridors may include such areas as greenbelts, refuge systems, underpasses, and biogeographic land bridges, for example. In general, a corridor is described as a linear habitat, embedded in a dissimilar matrix, which connects two or more large blocks of habitat. Wildlife movement corridors are critical for the survivorship of ecological systems for several reasons.

Corridors can connect water, food, and cover sources, spatially linking these three resources with wildlife in different areas. In addition, wildlife movement between habitat areas provides for the potential of genetic exchange between wildlife species populations, thereby maintaining genetic variability and adaptability to maximize the success of wildlife responses to changing environmental conditions. This is especially critical for small populations subject to loss of variability from genetic drift and effects of inbreeding. Naturally, the nature of corridor use and wildlife movement patterns varies greatly among species.

The project site was assessed for its ability to function as a wildlife corridor. The project site has an extensive riparian corridor in the western corner of the site that provides cover for migrating and nesting birds. It also provides foraging habitat for raptors and small and large mammals, including rodents and canids. The desert washes located within the western corner of the project boundaries are likely utilized by wildlife moving through the area; therefore, these features and associated riparian habitat would be considered necessary linkages between conserved natural habitat areas or critical for wildlife movement because of the nearby direct connectivity to wetlands to the south of the project site. The northern and southern boundaries are restricted by the All-American Canal to the north and the U.S./Mexico border wall borders the southern buffer of the BSA. Although the border wall inhibits large mammal movement, avian species and small mammals may fly over or cross through the wall.

The disturbed creosote bush scrub portion of the project site is sparse with low plant diversity, and therefore offers little shelter and foraging habitat. The project site is open with barriers to the north and south, leaving the terrain accessibility constrained for ground-truthing wildlife. The project borders the western edge of expansive agricultural fields and is surrounded to the north, west, and south by agriculture. Thus, the creosote scrub habitat only currently provides wildlife movement opportunities to the east because it consists of open and relatively unimpeded land. In conclusion, the creosote bush scrub habitat portion of the project site would not be considered a wildlife movement corridor that would need to be preserved to allow wildlife to move between important natural habitat areas due to the lack of conserved natural lands in the vicinity and the project's proximity to farming lands. The creosote bush scrub habitat within the project boundaries is exposed and does not contain any major features that would be considered critical movement corridors for wildlife. Therefore, the creosote bush habitat acts as more of a buffer between agricultural lands and wildlands to the east, but not as a corridor for wildlife.

Habitat Conservation Plans

The project site is not located in a Habitat Conservation Plan, Natural Community Conservation Plan, or other approved local, regional, or state habitat conservation plan.

3.5.2 Regulatory Setting

This section identifies and summarizes federal, state, and local laws, policies, and regulations that are applicable to the project.

Federal

Federal Endangered Species Act

The Federal Endangered Species Act (ESA) protects federally listed threatened and endangered species and their habitats from unlawful take and ensures that federal actions do not jeopardize the continued existence of a listed species or result in the destruction or adverse modification of

designated critical habitat. Under the ESA, “take” is defined as to harass, harm, pursue, hunt, shoot, wound, kill, trap, capture, or collect, or to attempt to engage in any such conduct. The U.S. Fish and Wildlife Service (USFWS) regulations define harm to mean “an act which actually kills or injures wildlife” (50 CFR 17.3).

Bald and Golden Eagle Protection Act of 1940

The Bald Eagle Protection Act of 1940 protects bald eagle (*Haliaeetus leucocephalus*) and golden eagle (*Aquila chrysaetos*) by prohibiting the taking, possession, and commerce of such birds and establishes civil penalties for violation of this Act. ‘Take’ is defined as “pursue, shoot, shoot at, poison, wound, kill, capture, trap, collect, molest or disturb.” ‘Disturb’ is defined as “to agitate or bother a bald or golden eagle to a degree that causes, or is likely to cause, based on the best scientific information available: (1) injury to an eagle, (2) a decrease in its productivity, by substantially interfering with normal breeding, feeding, or sheltering behavior, or (3) nest abandonment, by substantially interfering with normal breeding, feeding, or sheltering behavior” (72 *Federal Register* [FR] 31132; 50 CFR 22.3). All activities that may disturb or incidentally take an eagle or its nest as a result of an otherwise legal activity must be permitted by the USFWS under this Act.

Migratory Bird Treaty Act

The Migratory Bird Treaty Act (MBTA) prohibits the kill or transport of native migratory birds, or any part, nest, or egg of any such bird unless allowed by another regulation adopted in accordance with the MBTA. The prohibition applies to birds included in the respective international conventions between the U.S. and Great Britain, the U.S. and Mexico, the U.S. and Japan, and the U.S. and Russia. Disturbances that cause nest abandonment and/or loss of reproductive effort or the loss of habitats upon which these birds depend may be a violation of the MBTA. As authorized by the MBTA, the USFWS issues permits to qualified applicants for the following types of activities: falconry, raptor propagation, scientific collecting, special purposes (rehabilitation, education, migratory game bird propagation, and salvage), take of depredating birds, taxidermy, and waterfowl sale and disposal. The regulations governing migratory bird permits can be found in 50 CFR Part 13 General Permit Procedures and 50 CFR Part 21 Migratory Bird Permits. The State of California has incorporated the protection of birds of prey in Sections 3800, 3513, and 3503.5 of the California Fish and Game Code.

Section 404 Permit (Clean Water Act)

The purpose of the Clean Water Act (CWA) is to “restore and maintain the chemical, physical, and biological integrity of the nation’s waters.” Section 404 of the CWA prohibits the discharge of dredge and fill material into waters of the U.S., including wetlands, without a permit from the U.S. Army Corps of Engineers (USACE). Activities regulated under this program include fills for development, water resource projects (e.g., dams and levees), infrastructure development (e.g., highways and airports), and conversion of wetlands to uplands for farming and forestry. Either an individual 404b permit or authorization to use an existing USACE Nationwide Permit will need to be obtained if any portion of the construction requires fill into a river, stream, or stream bed that has been determined to be a jurisdictional waterway.

State

California Endangered Species Act

Provisions of CESA protect state-listed threatened and endangered species. The California Department of Fish and Wildlife (CDFW) regulates activities that may result in “take” of individuals (“take” means “hunt, pursue, catch, capture, or kill, or attempt to hunt, pursue, catch, capture, or kill”). Habitat degradation or modification is not expressly included in the definition of “take” under the California Fish and Game Code (FGC). Additionally, California FGC contains lists of vertebrate species designated as “fully protected” (California FGC Sections 3511 [birds], 4700 [mammals], 5050 [reptiles and amphibians], 5515 [fish]). Such species may not be taken or possessed.

In addition to state-listed species, CDFW has also produced a list of Species of Special Concern to serve as a “watch list.” Species on this list are of limited distribution or the extent of their habitats has been reduced substantially such that threats to their populations may be imminent. Species of Special Concern may receive special attention during environmental review, but they do not have statutory protection.

Birds of prey are protected in California under California FGC. Section 3503.5 states it is “unlawful to take, possess, or destroy any birds of prey (in the order Falconiformes or Strigiformes) or to take, possess, or destroy the nest or eggs of any such bird except as otherwise provided by this Code or any regulation adopted pursuant thereto.” Construction disturbance during the breeding season could result in the incidental loss of fertile eggs or nestlings or otherwise lead to nest abandonment.

California Fish and Game Code Section 1600 et. seq (as amended)

The California FGC Section 1600 et. seq. requires that a Notification of Lake or Streambed Alteration be submitted to CDFW for “any activity that may substantially divert or obstruct the natural flow or substantially change the bed, channel, or bank of any river, stream, or lake.” The CDFW reviews the proposed actions and, if necessary, submits to the Applicant a proposal for measures to protect affected fish and wildlife resources. The final proposal that is mutually agreed upon by CDFW and the Applicant is the Streambed Alteration Agreement (SAA). Often, projects that require an SAA also require a permit from the USACE under Section 404 of the CWA. In these instances, the conditions of the Section 404 permit and the SAA may overlap.

California Fish and Game Code Sections 3503, 3503.5, and 3513

Under Sections 3503, 3503.5, and 3513 of the California FGC, activities that would result in the taking, possessing, or destroying of any birds-of-prey, taking or possessing of any migratory nongame bird as designated by the MBTA, or the taking, possessing, or needlessly destroying of the nest or eggs of any raptors or non-game birds protected by the MBTA, or the taking of any non-game bird pursuant to FGC Section 3800 are prohibited. Additionally, the state further protects certain species of fish, mammals, amphibians and reptiles, birds, and mammals through CDFW’s Fully Protected Animals which prohibits any take or possession of classified species.

California Fish and Game Code Sections 1900-1913 (Native Plant Protection Act)

California’s Native Plant Protection Act prohibits the taking, possessing, or sale within the state of any plant listed by CDFW as rare, threatened, or endangered. This allows CDFW to salvage listed plant species that would otherwise be destroyed.

Porter-Cologne Water Quality Control Act

Under the Porter-Cologne Water Quality Control Act, all projects proposing to discharge waste that could affect waters of the State must file a waste discharge report with the appropriate regional board. The project falls under the jurisdiction of the Colorado River RWQCB.

California Environmental Quality Act

Title 14 CCR, Section 15380 requires the identification of endangered, rare, or threatened species or subspecies of animals or plants that may be impacted by a project. If any such species are found, appropriate measures should be identified to avoid, minimize, or mitigate the potential effects of projects.

Local

Imperial County General Plan

The Conservation and Open Space Element of the Imperial County General Plan provides detailed plans and measures for the preservation and management of biological and cultural resources, soils, minerals, energy, regional aesthetics, air quality, and open space. The purpose of this element is to recognize that natural resources must be maintained for their ecological value for the direct benefit to the public and to protect open space for the preservation of natural resources, the managed production of resources, outdoor recreation, and for public health and safety. In addition, the purpose of this element is to promote the protection, maintenance, and use of the County’s natural resources with particular emphasis on scarce resources, and to prevent wasteful exploitation, destruction, and neglect of the state’s natural resources. Table 3.5-3 analyzes the consistency of the project with specific policies contained in the Imperial County General Plan associated with biological resources.

Table 3.5-3. Project Consistency with General Plan Goals and Policies

General Plan Policies	Consistency with General Plan	Analysis
<p>Conservation and Open Space Element - <i>Open Space and Recreation Conservation</i></p> <p>Policy No. 2 - The County shall participate in conducting detailed investigations into the significance, location, extent, and condition of natural resources in the County.</p> <p>Program: Notify any agency responsible for protecting plant and wildlife before approving a project which would impact a rare, sensitive, or unique plant or wildlife habitat.</p>	<p>Consistent</p>	<p>A biological assessment has been conducted at the project site to evaluate the proposed project’s potential impacts on biological resources. No special-status plant species were identified within the BSA. Five special-status wildlife species, including burrowing owl, were identified within the project site. However, with implementation of Mitigation Measures BIO-1 through BIO-7, potential impacts to these species would be reduced to a level less than significant.</p> <p>Applicable agencies responsible for protecting plants and wildlife will be notified of the proposed project and provided an opportunity to comment on this EIR prior to the County’s consideration of any approvals for the project.</p>

Table 3.5-3. Project Consistency with General Plan Goals and Policies

General Plan Policies	Consistency with General Plan	Analysis
<p><i>Conservation of Environmental Resources for Future Generations</i></p> <p>Goal 1 - Environmental resources shall be conserved for future generations by minimizing environmental impacts in all land use decisions and educating the public on their value.</p> <p>Objective 1.6 - Promote the conservation of ecological sites and preservation of cultural resource sites through scientific investigation and public education.</p>	<p>Consistent</p>	<p>A biological assessment has been conducted at the project site to evaluate the project’s potential impacts on biological resources. No special-status plant species were identified within the BSA. Five special-status wildlife species, including burrowing owl, were identified within the BSA. However, with implementation of Mitigation Measures BIO-1 through BIO-7, potential impacts to these species would be reduced to a level less than significant.</p> <p>With implementation of Mitigation Measures BIO-1 through BIO-7, the project would not result in residual significant and unmitigable impacts on biological resources.</p>

Source: County of Imperial 1993
 BLM=Bureau of Land Management; CDFW – California Department of Fish and Wildlife; EIR – environmental impact report;
 USFWS – U.S. Fish and Wildlife Service

3.5.3 Impacts and Mitigation Measures

This section presents the significance criteria used for considering project impacts on biological resources, the methodology employed for the evaluation, an impact evaluation, and mitigation requirements, if necessary.

Thresholds of Significance

Based on CEQA Guidelines Appendix G, project impacts related to biological resources are considered significant if any of the following occur:

- Have a substantial adverse effect, either directly or through habitat modifications, on any species identified as a candidate, sensitive, or special status species in local or regional plans, policies, or regulations, or by the CDFW or USFWS
- Have a substantial adverse effect on any riparian habitat or other sensitive natural community identified in local or regional plans, policies, regulations or by the CDFW or USFWS
- Have a substantial adverse effect on state or federally-protected wetlands (including but not limited to, marsh, vernal pool, coastal, etc.) through direct removal, filling, hydrological interruption, or other means
- Interfere substantially with the movement of any native resident or migratory fish and wildlife species or with established native resident or migratory wildlife corridors, or impede the use of native wildlife nursery sites
- Conflict with any local policies or ordinances protecting biological resources, such as a tree preservation policy or ordinance
- Conflict with the provisions of an adopted Habitat Conservation Plan, Natural Community Conservation Plan, or other approved local, regional, or state habitat conservation plan

Methodology

This analysis evaluates the potential for the project, as described in Chapter 2, Project Description, to interact with local biological resources on the project site. Based on the extent of these interactions, this analysis considers whether these conditions would result in an exceedance of one or more of the applied significance criteria as identified above.

A biological resources technical report and aquatic resources delineation report were prepared for the project. The information obtained from the sources was reviewed and summarized to present the existing conditions and to identify potential environmental impacts, based on the significance criteria presented in this section. Impacts associated with biological resources that could result from project construction and operational activities were evaluated qualitatively based on-site conditions; expected construction practices; and materials, locations, and duration of project construction and related activities.

Impact Analysis

Impact 3.5-1 Would the project have a substantial adverse effect, either directly or through habitat modifications, on any species identified as a candidate, sensitive, or special status species in local or regional plans, policies, or regulations, or by the CDFW or USFWS?

SOLAR ENERGY FACILITY, BATTERY STORAGE SYSTEM, AND GEN-TIE LINE

Construction

SPECIAL-STATUS PLANTS

As stated above, the literature review identified 14 special-status plant species that have the potential to occur within the project site. However, 11 of these plant species have a low potential to occur due to limited suitable habitat. There is moderate potential for three rare plant species, Abram's spurge (CRPR 2B.2), Wiggins' croton (CRPR 2B.2), and sand food (CRPR 1B.2), to be present within the project area. Suitable habitat for these species is present within the creosote bush scrub and disturbed creosote bush – white bursage scrub habitats. Impacts that may occur to the species during project construction includes loss of individuals, habitat, and seedbank. Depending on the size of the population, potential impacts be significant. Implementation of Mitigation Measures BIO-1, BIO-2, and BIO-3 would reduce impacts to a level less than significant.

SPECIAL-STATUS WILDLIFE

The literature review identified 21 special-status wildlife species that have the potential to occur within the project site. However, six of these species have a low or no potential to occur due to the lack of suitable and/or limited habitat within the project site. Wildlife species that are presumed absent from the project site include Gila woodpecker, western mastiff bat, and big free-tailed bat. Wildlife species with a low potential to occur include Sonoran Desert toad, red-diamond rattlesnake, and southwestern willow flycatcher.

Five special-status wildlife species were observed on site during the habitat assessment: black-tailed gnatcatcher, northern harrier, burrowing owl, yellow warblers, and loggerhead shrikes were observed in the tamarisk thickets in the western portion of the project site. Burrowing owl and their burrows were observed within the disturbed creosote-white bursage scrub in the western portion of the project site,

within a berm adjacent to the access road, and in a concrete pile in the northeastern corner of the site. The proposed project has been designed to avoid impacts to tamarisk thickets occurring on the project site. As shown on the Site Plan (Figure 2-3), project components would not be sited on the project site where tamarisk thickets are present. This vegetation community would not be removed on the project site thereby avoiding habitat removal. However, there is still potential that construction activities occurring adjacent to this vegetation community could result in direct and indirect impacts on special-status species. Direct construction-related impacts to wildlife species that could occur include injury, mortality, nest failures, and loss of young. Indirect impacts include increase in anthropogenic effects (i.e., noise levels, introduction of invasive/nonnative species, increase in human activity, and increase in dust. However, implementation of Mitigation Measures BIO-2, BIO-3, BIO-4, BIO-5, and BIO-6 would reduce potential impacts to a level less than significant.

Foraging habitat for a number of raptor species and breeding habitat for numerous passerine species that are protected by the MBTA occurs throughout the project site. The project site provides nesting habitat for ground-nesting species as well as species that nest in riparian scrub habitat. Due to the lack of large trees within the survey area, there is no suitable nesting habitat for raptor species. However, northern harriers are ground nesters; therefore, the tamarisk thicket and disturbed arrow weed thicket habitats provide potential nesting habitat for this species. Direct impacts to nesting avian species include injury, mortality, loss of young, and nest failure. Indirect impacts include loss of foraging and nesting habitat for passerine and raptors species, increase in noise and human activities, and potential introduction of invasive/nonnative species. Potential impacts would be considered significant. Implementation of Mitigation Measures BIO-2, BIO-5, and BIO-6 would reduce potential impacts to a level less than significant.

The palm trees located within the project site may provide roosting habitats for bat species, particularly western yellow bat, a SSC species. These trees could function as maternity roost sites for this species. During the 2022 assessment of the access road, a bat roost was observed within the bridge at Gordon Wells Road that crosses the offline storage canal, north of the All-American Canal. Bat species in California are protected by Section 4150 (protection of non-game mammals from take) of the California Fish and Game Code. Section 4150 of the California Fish and Game Code prohibits the take of any naturally occurring mammals in California that are nongame mammals, which includes all species of the Order Chiroptera (bats). Based on the quantity of bats within the bridge and the timing of the observation of the colony, there is high likelihood that this is a maternity roost. The Gordon Wells Road bridge will be used for access to the solar field portion of the project site and no direct impacts are expected to occur to the bridge. However, there may be indirect impacts to the roost through noise and vibration, due to a temporary increase in traffic above the bridge during construction. However, because the bridge currently functions as an active roadway, the colony would be expected to be accustomed to noise and vibrations associated with traffic and indirect impacts would not be expected to be significant. The solar facility site is located approximately 22 miles west of the bridge and work is expected to occur within a 12-month period. An increase in truck traffic over the bridge to facilitate construction of the project is not expected to have a significant impact on the bat colony and will be temporary in nature.

Operation

All electrical components on the project site shall be either undergrounded or protected so that there will be no exposure to wildlife and therefore no potential for electrocution. Additionally, based on the Avian Powerline Interaction Committee's (APLIC) 1996 report on power line electrocution in the U.S., avian electrocution risk is highest along distribution lines (generally less than 69 kV) where the

distance between energized phases, ground wires, transformers, and other components of an electrical distribution system are less than the length or skin-to-skin contact distance of birds. The distance between energized components along transmission lines (>69 kV) is generally insufficient to present avian electrocution risk. Therefore, no impact to avian is anticipated to occur due to electrocution along the proposed gen-tie line.

CONSTRUCTION ACCESS ROAD

During construction, vendors and heavy construction equipment would access the project site via Gordon Wells Road approximately 20 miles east of the project site, then travel west along an existing dirt road paralleling the U.S./Mexico Border. This existing dirt road is actively used by the U.S. Border Patrol during patrol operations. The dirt road is on urban/developed land. The use of this access road during construction is not anticipated to result in potential impacts on biological resources, with the exception of roosting bats, if present. Bat acoustic surveys and monitoring should be implemented to determine if sensitive bat species occur within the Gordon Road Wells bridge or palm trees (if planned for removal). All bat species with potential for occurrence for the project are SSC species and potential project-related impacts to bat species and bat maternity roosts are considered significant. Implementation of BIO-7 would reduce impacts to bat species and maternity roosts to a level less than significant.

Because vehicles and construction equipment would be required to stay within the existing boundaries of the dirt road to avoid and/or minimize ground disturbance to undisturbed and vegetated areas, other impacts to biological resources are not anticipated. Furthermore, the project applicant would not make improvements to the existing dirt road except for the application of water for dust suppression.

Mitigation Measure(s)

BIO-1 Rare Plant Surveys. Prior to initiating ground disturbance, rare plant surveys shall be conducted within suitable habitat on the project site during the appropriate blooming period for the Abrams' spurge (approximately September through November), Wiggins' croton (approximately March through May), and sand food (approximately April through June). The surveys shall be conducted by a botanist or qualified biologist in accordance with the USFWS Guidelines for Conducting and Reporting Botanical Inventories for Federally Listed, Proposed, and Candidate Plants (USFWS 1996); the CDFW Protocols for Surveying and Evaluating Impacts to Special Status Native Plant Populations and Sensitive Natural Communities (CDFW 2018); and the CNPS Botanical Survey Guidelines (CNPS 2001). If any special-status species are observed during the rare plant surveys, the location of the individual plant or population will be recorded with a submeter GPS device for mapping purposes. If project-related impacts to rare plants on the project site are unavoidable, then consultation with CDFW may be required to develop a mitigation plan or additional avoidance and minimization measures. Mitigation measures that may be implemented if the species is observed include establishing a no-disturbance buffer around locations of individuals or a population, salvage or seed collection, and additional monitoring requirements.

BIO-2 General Impact Avoidance and Minimization Measures. The following measures will be applicable throughout the life of the project:

- To reduce the potential indirect impact on migratory birds, bats and raptors, the project will comply with the APLIC 2012 Guidelines for overhead utilities, as appropriate, to minimize avian collisions with transmission facilities (APLIC 2012)

- All electrical components on the project site shall be either undergrounded or protected so that there will be no exposure to wildlife and therefore no potential for electrocution.
- The project proponent shall designate a Project Biologist who shall be responsible for overseeing compliance with protective measures for the biological resources during vegetation clearing and work activities within and adjacent to areas of native habitat. The Project Biologist will be familiar with the local habitats, plants, and wildlife. The Project Biologist will also maintain communications with the Contractor to ensure that issues relating to biological resources are appropriately and lawfully managed and monitor construction. The Project Biologist will monitor activities within construction areas during critical times, such as vegetation removal, the implementation of Best Management Practices (BMP), and installation of security fencing to protect native species. The Project Biologist will ensure that all wildlife and regulatory agency permit requirements, conservation measures, and general avoidance and minimization measures are properly implemented and followed.
- The boundaries of all areas to be newly disturbed (including solar facility areas, staging areas, access roads, and sites for temporary placement of construction materials and spoils) will be delineated with stakes and flagging prior to disturbance. All disturbances, vehicles, and equipment will be confined to the flagged areas.
- No potential wildlife entrapments (e.g., trenches, bores) will be left uncovered overnight. Any uncovered pitfalls will be excavated to 3:1 slopes at the ends to provide wildlife escape ramps. Alternatively, man-made ramps may be installed. Covered pitfalls will be covered completely to prevent access by small mammals or reptiles.
- To avoid wildlife entrapment (including birds), all pipes or other construction materials or supplies will be covered or capped in storage or laydown area, and at the end of each workday in construction, quarrying and processing/handling areas. No pipes or tubing of sizes or inside diameters ranging from 1 to 10 inches will be left open either temporarily or permanently.
- No anticoagulant rodenticides, such as Warfarin and related compounds (indandiones and hydroxycoumarins), may be used within the project site, on off-site project facilities and activities, or in support of any other project activities.
- Avoid wildlife attractants. All trash and food-related waste shall be placed in self-closing containers and removed regularly from the site to prevent overflow. Workers shall not feed wildlife. Water applied to dirt roads and construction areas for dust abatement shall use the minimal amount needed to meet safety and air quality standards to prevent the formation of puddles, which could attract wildlife. Pooled rainwater or floodwater within retention basins will be removed to avoid attracting wildlife to the active work areas.
- To minimize the likelihood for vehicle strikes on wildlife, speed limits will not exceed 15 miles per hour when driving on access roads. All vehicles required for O&M must remain on designated access/maintenance roads.

- Avoid night-time construction lighting or if nighttime construction cannot be avoided use shielded directional lighting pointed downward and towards the interior of the project site, thereby avoiding illumination of adjacent natural areas and the night sky.
- All construction equipment used for the Project will be equipped with properly operating and maintained mufflers.
- Hazardous materials and equipment stored overnight, including small amounts of fuel to refuel hand-held equipment, will be stored within secondary containment when within 50 feet of open water to the fullest extent practicable. Secondary containment will consist of a ring of sandbags around each piece of stored equipment/structure. A plastic tarp/Visqueen lining with no seams shall be placed under the equipment and over the edges of the sandbags, or a plastic hazardous materials secondary containment unit shall be utilized by the Contractor.
- The Contractor will be required to conduct vehicle refueling in upland areas where fuel cannot enter waters of the U.S. and in areas that do not have potential to support federally threatened or endangered species. Any fuel containers, repair materials, including creosote-treated wood, and/or stockpiled material that is left on site overnight, will be secured in secondary containment within the work area and staging/assembly area and covered with plastic at the end of each work day.
- In the event that no activity is to occur in the work area for the weekend and/or a period of time greater than 48 hours, the Contractor will ensure that all portable fuel containers are removed from the project site.
- All equipment will be maintained in accordance with manufacturer's recommendations and requirements.
- Equipment and containers will be inspected daily for leaks. Should a leak occur, contaminated soils and surfaces will be cleaned up and disposed of following the guidelines identified in the Stormwater Pollution Prevention Plan or equivalent, Materials Safety Data Sheets, and any specifications required by other permits issued for the project.
- The Contractor will utilize off-site maintenance and repair shops as much as possible for maintenance and repair of equipment.
- If maintenance of equipment must occur onsite, fuel/oil pans, absorbent pads, or appropriate containment will be used to capture spills/leaks within all areas. Where feasible, maintenance of equipment will occur in upland areas where fuel cannot enter waters of the U.S. and in areas that do not have potential to support federally threatened or endangered species.
- Appropriate BMPs will be used by the Contractor to control erosion and sedimentation and to capture debris and contaminants from bridge construction to prevent their deposition in waterways. No sediment or debris will be allowed to enter the creek or other drainages. All debris from construction of the bridge will be contained so that it does not fall into channel. Appropriate BMPs will be used by the Contractor during construction to limit the spread of resuspended sediment and to contain debris.

- Erosion and sediment control devices used for the proposed project, including fiber rolls and bonded fiber matrix, will be made from biodegradable materials such as jute, with no plastic mesh, to avoid creating a wildlife entanglement hazard.
- Firearms, open fires, and pets would be prohibited at all work locations and access roads. Smoking would be prohibited along the Project alignment.
- Cross-country vehicle and equipment use outside of approved designated work areas and access roads shall be prohibited to prevent unnecessary ground and vegetation disturbance.
- Any injured or dead wildlife encountered during project-related activities shall be reported to the project biologist, biological monitor, CDFW, or a CDFW-approved veterinary facility as soon as possible to report the observation and determine the best course of action. For special-status species, the Project Biologist shall notify the County, USFWS, and/or CDFW, as appropriate, within 24 hours of the discovery.
- Stockpiling of material will be allowed only within established work areas.
- Actively manage the spread of noxious weeds
- The ground beneath all parked equipment and vehicles shall be inspected for wildlife before moving.

BIO-3

Worker Environmental Awareness Program. Prior to project construction, a Worker Environmental Awareness Program shall be developed and implemented by a qualified biologist and shall be available in both English and Spanish. Handouts summarizing potential impacts to special-status biological resources and the potential penalties for impacts to these resources shall be provided to all construction personnel. At a minimum, the education program shall include the following:

- The purpose for resource protection;
- A description of special-status species including representative photographs and general ecology;
- Occurrences of USACE, RWQCB, and CDFW regulated features in the Project study area;
- Regulatory framework for biological resource protection and consequences if violated
- Sensitivity of the species to human activities;
- Avoidance and minimization measures designed to reduce the impacts to special-status biological resources;
- Environmentally responsible construction practices;
- Reporting requirements;
- The protocol to resolve conflicts that may arise at any time during the construction process; and

- Workers sign acknowledgement form indicating that the Environmental Awareness Training and Education Program that has been completed and would be kept on record

BIO-4

Burrowing Owl Avoidance and Minimization. Take Avoidance (pre-construction) surveys for burrowing owl shall be completed prior to project construction. Surveys shall be conducted as detailed within Appendix E of the Staff Report on Burrowing Owl Mitigation (California Department of Fish and Game [CDFG] 2012). If burrowing owl is not detected, construction may proceed.

- If burrowing owl is identified during the non-breeding season (September 1 through January 31), then a 50-meter buffer will be established by the biological monitor. Construction within the buffer will be avoided until a qualified biologist determines that burrowing owl is no longer present or until a CDFW-approved exclusion plan has been implemented. The buffer distance may be reduced if noise attenuation buffers such as hay bales are placed between the occupied burrow and construction activities.
- If burrowing owl is identified during the breeding season (February 1 through August 31), then an appropriate buffer will be established by the biological monitor in accordance with the *Staff Report on Burrowing Owl Mitigation* (CDFG 2012). Construction within the buffer will be avoided until a qualified biologist determines that burrowing owl is no longer present or until young have fledged. The buffer distance may be reduced in consultation with CDFW if noise attenuation buffers such as hay bales are placed between the occupied burrow and construction activities.

BIO-5

Pre-Construction Nesting Bird Survey. If construction or other project activities are scheduled to occur during the bird breeding season (typically February 1 through August 31 for raptors and March 15 through August 31 for the majority of migratory bird species), a pre-construction nesting-bird survey shall be conducted by a qualified avian biologist to ensure that active bird nests, including those for the black-tailed gnatcatcher, northern harrier, yellow warbler, burrowing owl, and loggerhead strike, will not be disturbed or destroyed. The survey shall be completed no more than three days prior to initial ground disturbance. The nesting-bird survey shall include the project site and adjacent areas where project activities have the potential to affect active nests, either directly or indirectly due to construction activity or noise. If an active nest is identified, the biologist shall establish an appropriately sized disturbance-limit buffer around the nest using flagging or staking. Construction activities shall not occur within any disturbance-limit buffer zones until the nest is deemed inactive by the qualified biologist. If construction activities cease for a period of greater than three days during the bird breeding season, a pre-construction nesting bird survey shall be conducted prior to the commencement of activities. Final construction buffers or setback distances shall be determined by the qualified biologist in coordination with USFWS and CDFW on a case-by-case basis, depending on the species, season in which disturbance shall occur, the type of disturbance, and other factors that could influence susceptibility to disturbance (topography, vegetation, existing disturbance levels, etc.).

BIO-6 Pre-Construction Survey for Special-Status Species. A pre-construction survey shall be conducted for special-status wildlife species within all areas of potential permanent and temporary disturbance. The pre-construction survey shall take place no more than 14 days prior to the start of ground-disturbing activities. The pre-construction surveys should take place regardless of breeding season timing and shall focus on identifying the presence of special-status wildlife species present on the project site or that were identified as having a high potential to occur on the site. These species include, but are not limited to, flat-tailed horned lizard, burrowing owl, northern harrier, black-tailed gnatcatcher, and yellow warbler. Should any special-status species be identified during the pre-construction survey, consultation to develop suitable avoidance and minimization measures with the appropriate agency (USFWS, CDFW) may need to be undertaken.

BIO-7 Bat Acoustic Surveys and Monitoring. To avoid impacts to bat species, a qualified bat biologist shall conduct an appropriate combination of sampling, exit counts, and acoustic surveys to determine if bats are using the palm tree resources in the project area. If project-related impacts to bat species are unavoidable, additional measures may need to be implemented to reduce or eliminate impacts to bat species, including maternity roosts, such as tree removal occurring outside of bat breeding season (October through February) or two-step, two-day removal of palm trees under supervision of a qualified bat biologist.

Significance After Mitigation

Project construction has the potential to directly impact special-status wildlife species. However, implementation of Mitigation Measures BIO-1 through BIO-7 would reduce potential impacts to a less than significant level.

Impact 3.5-2 Would the project have a substantial adverse effect on any riparian habitat or other sensitive natural community identified in local or regional plans, policies, regulations or by the CDFW or USFWS?

SOLAR ENERGY FACILITY, BATTERY STORAGE SYSTEM, AND GEN-TIE LINE

RIPARIAN HABITAT

Both riparian habitat and disturbed riparian habitat are present within the project site. They are associated with the floodplain adjacent to the wetlands and drainages throughout the site. A total of 5.8 acres of riparian habitat and 8.22 acres of disturbed riparian habitat exists within the project site. The proposed project has been designed to avoid impacts to the riparian habitat and disturbed riparian habitat on the project site. As shown on the Site Plan (Figure 2-3), project components would not be sited on the project site where riparian habitat and disturbed riparian habitats are present. Solar panels, structures, and new access roads will not be placed within 50 feet of wetland and riparian habitat boundaries. Therefore, the proposed project would have no impact on riparian habitats.

SENSITIVE NATURAL COMMUNITIES

Tamarisk thicket occurs within the project site and is considered a sensitive natural community by CDFW. The proposed project has been designed to avoid impacts to this sensitive natural community. As shown on the Site Plan (Figure 2-3), project components would not be sited on the project site

where tamarisk thickets are present. Implementation of the project would result in no impact on sensitive natural communities.

CONSTRUCTION ACCESS ROAD

The existing dirt access road is on urban/developed land. No riparian habitat or sensitive natural communities are located within or adjacent to the access road. Therefore, the use of the access road during construction would have no impact on riparian or sensitive natural communities.

Mitigation Measure(s)

No mitigation is required.

Impact 3.5-3 Would the project have a substantial adverse effect on state or federally-protected wetlands (including but not limited to, marsh, vernal pool, coastal, etc.) through direct removal, filing, hydrological interruption, or other means?

SOLAR ENERGY FACILITY, BATTERY STORAGE SYSTEM, AND GEN-TIE LINE

The *Aquatic Resources Delineation Report* prepared for the project (Appendix E of this EIR) identified 11 aquatic resources on the project site and access road (see Table 3.5-2 and Figure 3.5-12 through Figure 3.5-17). The proposed project has been designed to avoid impacts to aquatic resources. As shown on the Site Plan (Figure 2-3), project components would not be sited on the project site where aquatic resources are present. Implementation of the project would result in no impact on state or federally protected aquatic resources.

CONSTRUCTION ACCESS ROAD

The existing dirt access road is on urban/developed land. No aquatic resources are located within or adjacent to the access road. Therefore, the use of the access road during construction would have no impact on riparian or sensitive natural communities.

Mitigation Measure(s)

No mitigation is required.

Impact 3.5-4 Would the project interfere substantially with the movement of any native resident or migratory fish and wildlife species or with established native resident or migratory wildlife corridors, or impede the use of native wildlife nursery sites?

SOLAR ENERGY FACILITY, BATTERY STORAGE SYSTEM, AND GEN-TIE LINE

The project site is located adjacent to areas containing existing disturbances (i.e., roads, border wall, and active agricultural land). The majority of the project site does not contain suitable vegetation and/or cover to support wildlife movement and is nestled on the edge of agricultural and development; therefore, wildlife movement opportunities connecting the project site to large, undeveloped natural areas is extremely limited. Wildlife will be able to continue to use the riparian habitat and surrounding agricultural lands as a potential corridor and nursery site. The proposed project is not expected to significantly impact wildlife movement through the project vicinity and a less than significant impact would occur.

ACCESS ROAD

The existing dirt access road is on urban/developed land. Therefore, the use of the access road during construction would have no impact on wildlife movement.

Mitigation Measure(s)

No mitigation is required.

Impact 3.5-5 Would the project conflict with any local policies or ordinances protecting biological resources, such as a tree preservation policy or ordinance?

SOLAR ENERGY FACILITY, BATTERY STORAGE SYSTEM, AND GEN-TIE LINE

The proposed project consists of the construction and operation of a solar energy facility and associated electrical transmission lines. Development of the solar facility is subject to the County's zoning ordinance.

The project site is located on three privately owned legal parcels zoned Heavy Agriculture with a Renewable Energy Zone Overlay (A-3-RE). Pursuant to Title 9, Division 5, Chapter 9, "Solar Energy Plants" and "Transmission lines, including supporting towers, poles microwave towers, utility substations" are uses that are permitted in the A-3 Zone, subject to approval of a CUP from Imperial County.

As demonstrated in Table 3.5-3 and discussed further in Section 3.11 Land Use Planning, with approval of a CUP, the project would be consistent with Imperial County General Plan, and with biological resources policies contained therein. Therefore, implementation of the proposed project would not result in a significant impact associated with the project's potential to conflict with local policies protecting biological resources.

CONSTRUCTION ACCESS ROAD

The use of the access road during construction is not anticipated to result in potential impacts on biological resources because vehicles and construction equipment would be required to stay within the existing boundaries of the dirt road to avoid and/or minimize ground disturbance to undisturbed and vegetated areas. Furthermore, the project applicant would not make improvements to the existing dirt road except for the application of water for dust suppression. Based on these considerations, the use of the access road during construction would not conflict with local policies protecting biological resources.

Mitigation Measure(s)

No mitigation is required.

Impact 3.5-6 Would the project conflict with the provisions of an adopted Habitat Conservation Plan, Natural Community Conservation Plan, or other approved local, regional, or state habitat conservation plan?

SOLAR ENERGY FACILITY, BATTERY STORAGE SYSTEM, AND GEN-TIE LINE

The project site is not located in a Habitat Conservation Plan, Natural Community Conservation Plan, or other approved local, regional, or state habitat conservation plan. Implementation of the proposed project would result in no impact associated with the potential to conflict with local conservation plans.

CONSTRUCTION ACCESS ROAD

The construction access road is not located in a Habitat Conservation Plan, Natural Community Conservation Plan, or other approved local, regional, or state habitat conservation plan. Therefore, the use of the access road during construction would result in no impact associated with the potential to conflict with local conservation plans.

Mitigation Measure(s)

No mitigation is required.

3.5.4 Decommissioning/Restoration and Residual Impacts

Decommissioning/Restoration

If at the end of the PPA term, no contract extension is available for a power purchaser, no other buyer of the energy emerges, or there is no further funding of the project, the project will be decommissioned and dismantled. Project decommissioning activities will require construction vehicles to drive across the solar facility, transmission line, and access roads. Concrete footings, foundations, and pads would be removed using heavy equipment and recycled at an off-site location. All remaining components would be removed, and all disturbed areas would be reclaimed and recontoured. Similar to project construction, decommissioning activities have the potential to directly impact special-status species. Nesting birds and burrowing owl could occupy the project site as well as habitat abutting the access roads or gen-tie line. Adjacent native habitats could be degraded by the introduction of invasive species or by wildlife caused by construction activities. These impacts could be significant. However, implementation of Mitigation Measures BIO-1 through BIO-7 at the time of decommissioning would reduce impacts to a level less than significant.

Residual

The project does not impact state or federally protected wetlands, does not conflict with any local policies or ordinances protecting biological resources and does not conflict with the provisions of an adopted Habitat Conservation Plan, Natural Community Conservation Plan, or other approved local, regional, or state habitat conservation plan.

With the implementation of Mitigation Measures BIO-1 through BIO-7, potential impacts to special-status species would be reduced to a level less than significant.

Therefore, the project would not result in residual significant and unmitigable impacts related to biological resources.

This page is intentionally blank.

3.6 Cultural Resources

This section discusses cultural resources that may be potentially impacted by the proposed project. The following identifies the existing cultural resources within the project site, analyzes potential impacts of the proposed project, and recommends mitigation measures to avoid or reduce potential impacts of the proposed project.

Information for this section is summarized from the Cultural Resources Inventory prepared by ECORP Consulting, Inc. This report is included in Appendix F of this EIR. The cultural resources inventory included a records search, literature review, and field survey.

The Area of Potential Effects (APE), or project area, consists of the horizontal and vertical limits of a project and includes the area within which significant impacts to historical resources or historic properties could occur as a result of the project. The APE is defined for projects subject to regulations implementing Section 106 (federal law and regulations). For projects subject to CEQA and for the purposes of this EIR, the term “project area” is used rather than APE.

The horizontal limit of the project area includes areas proposed for construction, vegetation removal, grading, trenching, stockpiling, staging, and paving. The horizontal limit of the project area measures approximately 528 acres. It should be noted that the project applicant re-designed the project to remove the western parcel (APN 059-209-010) after the completion of the Cultural Resources Inventory Report and field survey. This re-design reduced the original project site to 450 acres. The Cultural Resources Inventory Report and field survey covered the original project footprint.

The vertical limit of the project area is described as the maximum depth below the surface to which excavations for project foundations and facilities will extend. Therefore, the vertical limit includes all subsurface areas where archaeological deposits could be affected. The subsurface vertical limit varies across the project, depending on the depth of the grading or trenching for installation of facilities. The Cultural Resources Inventory assumes it could extend as deep as 10 feet below the current surface; therefore, review of geologic and soils maps was necessary to determine the potential for buried archaeological sites that cannot be seen on the surface.

The vertical limit also is described as the maximum height of structures that could impact the physical integrity and integrity of setting of cultural resources, including districts and traditional cultural properties. The Cultural Resources Inventory assumes the above-surface vertical limit is up to 30 feet above the surface.

3.6.1 Existing Conditions

Cultural Setting

Regional Pre-contact History

EARLY HOLOCENE (10,000-6,500 BP) AND MIDDLE HOLOCENE (6,500-3,500 BP)

The Salton Trough area of the Colorado Desert has little archaeological material dating to the Early and Middle Holocene. The only indications of use of this area during this period of time consist of large bifacial dart points found on relic lake beds of Lake Cahuilla and on desert pavement. These include projectile point types common in the Mojave Desert such as Lake Mojave, Pinto, and Elko. The sparse occupation during the Middle Holocene may be related to extremely arid climatic conditions and of the lack of water in the Salton Trough (absence of Lake Cahuilla). The Salton Sea Naval Test Base study

has produced evidence for Archaic occupation on the west side of the Salton Trough. Pinto and Elko series projectile points recovered during investigations at the Test Base yielded a date of 5,840 ±250 years BP. This data suggests that the desert area of southeastern California was not entirely abandoned during the Middle Holocene. While the population of the region was probably sparse, small bands of mobile people most likely moved among areas where water (at springs) and plant food resources were available (Appendix F of this EIR).

LATE ARCHAIC PERIOD (3,000 TO 1,300 BP)

A few temporary camps with living surfaces and hearths dating to the period 3,000 to 1,300 BP (Late Archaic Period) are located away from the lakebed in canyons and in the upper Coachella Valley above the maximum lake level. However, two temporary camps dating to the first millennium BC that contain fish and waterfowl bone in the Coachella Valley along the maximum Lake Cahuilla shoreline indicate there may have been a lake stand during this period (Appendix F of this EIR).

LATE PERIOD (1,300 BP TO CONTACT)

Higher population and greater numbers of sites appear to correlate with the presence of Lake Cahuilla, which filled the Salton Trough when water flowed into the trough from the Colorado River. When water ceased to flow from the river, the lake dried, markedly reducing the availability of resources. When the lake was present, lacustrine resources such as fish, shellfish, and waterfowl were available. When the lake was absent, very few resources were available and human population was low. To the northwest, in the Coachella Valley, the intermittent Whitewater River entered Lake Cahuilla near Point Happy between what is now Indian Wells and Indio. Several late pre-contact archaeological sites have been investigated along the ancient Lake Cahuilla shoreline in this area. To the south, the entire Imperial Valley between East Mesa and West Mesa was underwater when Lake Cahuilla was present (Appendix F of this EIR).

The southern part of the Salton Trough was occupied by ancestors of the Yuman-speaking Tipai, Kumeyaay, or Kamia. This area included the Imperial Valley, the Yuha Desert, and the mountains to the west and east. The lower Colorado River area was occupied by ancestors of the Yuman-speaking Quechan. However, Late Prehistoric archaeological sites in this area belong to the Patayan. Patayan I begins about 1,300 BP and is indicated archaeologically by the presence of small arrow points and by the appearance of Black Mesa Buff and Colorado Beige ceramics along the Colorado River. Patayan ceramics first appeared about 1,200 BP on the east shore of Lake Cahuilla and were probably introduced by Yuman people from the Colorado River. Within other areas of the the southern Salton Trough, ceramics first appear about 1,000 BP at the beginning of Patayan II. Later Patayan II (AD 1000 – 1700) and III (AD 1700 – 1850) ceramics include Tumco Buff and Colorado Buff.

Along the lower Colorado River, the Patayan settlement-subsistence system consisted of horticulture, hunting, and gathering in riparian habitats. People lived in multi-seasonal residential bases along the river. When Lake Cahuilla was present in the Salton Trough, they also occupied temporary camps for fishing, hunting, and gathering on the eastern shore of Lake Cahuilla. On the west side of the Salton Trough, the Patayan pattern consisted of a seasonal round among upland and lowland habitats. When Lake Cahuilla was present, seasonal residential bases and temporary camps were occupied on the western shore of Lake Cahuilla in order to obtain lacustrine resources including fish, shellfish, and waterfowl.

During the Late Period, the northern part of the Salton Trough (northern Salton Sea area and the Coachella Valley) was occupied by ancestors of the Takic-speaking Cahuilla. They also occupied the adjacent Santa Rosa and San Jacinto mountains. Floral remains indicated use of these sites during

all four seasons. These large multi-seasonal residential bases were likely occupied during the three Lake Cahuilla lake stands between AD 1200 and 1680, along the ancient shorelines in the Coachella Valley. These sites also contain abundant fish bone, waterfowl bone, and shell from freshwater shellfish which indicate use of both lowland and upland resources. Typical artifacts at these sites include cottonwood and desert side-notched arrow points, buff ware ceramics, and late pre-contact marine shell beads.

The Colorado Desert area northeast of the Salton Trough, including the Chuckwalla Valley area, was probably used intermittently prior to AD 1200 by small groups of Yuman-speaking hunter-gatherers who had residential bases or villages along the Colorado River. These sites would consist of small temporary camps and lithic scatters. Ancestors of the Numic-speaking Chemehuevi moved into the southeastern Mojave Desert and northeastern Colorado Desert (including Chuckwalla Valley) on the west side of the Colorado River about AD 1200. Because the Chemehuevi did not have access to the Colorado River Valley, which was still occupied by Yuman speakers, their use of the desert area was more intensive. Therefore, temporary camps used by ancestors of the Chemehuevi as well as lithic scatters, should be larger than those dating prior to AD 1200. Pottery is present in some of the temporary camps and consists of either locally made brown ware or buff ware that was obtained through trade with the Colorado River groups.

Obsidian from the Obsidian Butte source on the southeast margin of the Salton Sea was used for making flaked-stone tools throughout southern California during the Late Period. However, obsidian from Obsidian Butte could only be obtained when lake levels were low, since it is at an elevation of -40 meters (130 feet) below sea level. It is possible that the Imperial Valley Yumans traded obsidian for food resources from other groups when lacustrine resources from Lake Cahuilla were not available. Exchange patterns are also indicated by the presence of numerous marine shell beads (made in the coastal Chumash area) in late pre-contact Takic-speaking Cahuilla sites, but not in Yuman-speaking areas.

Ethnohistory

The Kumeyaay (also known as Ipai and Tipai) are the Yuman-speaking native people of central and southwestern Imperial County, central and southern San Diego County, and the northern Baja Peninsula in Mexico. The ancestral lands of the Kumeyaay extend north from Todos Santos Bay near Ensenada, Mexico to Agua Hedionda Lagoon in north San Diego County, and east to the Imperial Valley. Village locations were selected for seasonal use and were occupied by exogamous, patrilineal clans or bands. Kumeyaay lived in residential bases during the winter and subsisted on stored resources. No permanent houses were built. Brush shelters were temporary and were not reused the next year. Ceremonies, including rites of passage and ceremonies were held in the winter residential bases. The Kumeyaay were geographically and linguistically divided into western and eastern Kumeyaay. The western Kumeyaay lived along the coast and in the valleys along the drainages west of the mountains. The eastern Kumeyaay lived in the canyons and desert east of the mountains. The eastern and western Kumeyaay met in the mountains in the fall, where they gathered black oak acorns, traded, and held ceremonies (Appendix F of this EIR).

Beginning in 1775, the seminomadic life of the Kumeyaay began to change as a result of contact with Euro-Americans, particularly from the influence of the Spanish missions. Through successive Spanish, Mexican, and Anglo-American control, the Kumeyaay were forced to adopt a sedentary lifestyle and accept Christianity.

Regional History

In September of 1771, Father Francisco Garcés followed the Gila River west to its confluence with the Colorado River, traveled south to the Laguna de Salada in Baja California, then turned northwest until he reached the southern end of Imperial Valley. Garcés and his party were the first Europeans to see the Salton Sink region. After his return to Mexico, Garcés talked of his discovery to Captain Juan Bautista de Anza, the commander of the Spanish presidio at Tubac, in what is now southern Arizona. Anza wrote to the Viceroy of Mexico, Antonio María Bucareli Ursúa, and received permission to mount an expedition to cross the Colorado River into California. The Anza expedition crossed the Colorado River near Yuma, entering the Colorado Desert. Rather than crossing or skirting the extensive sand dunes that lie west of Yuma, Anza followed the river south into Baja California, then turned north. After about three weeks of hardship, the expedition reached Imperial Valley west of the future site of Calexico. After crossing Borrego Valley and the Santa Rosa Mountains, Anza and his men reached Mission San Gabriel in Los Angeles on March 22, 1774, having become the first Europeans to cross the Colorado Desert and what would later be known as Imperial Valley (Appendix F of this EIR).

The first proposal to irrigate the Colorado Desert for agriculture came from Dr. Oliver M. Wozencraft after he saw Indians cultivating plots during an exploratory trip in May of 1849. Wozencraft secured the rights to 1,600 square miles of desert land in the Salton Sink from the California Legislature in 1859 with engineer Charles R. Rockwood directing operations. In 1891, the Colorado River Irrigation Company was formed. In 1896, Rockwood formed the California Development Company and Canadian capitalist George Chaffey, the founder of Ontario, California, provided funding and promotion for the company in 1900. By 1902, the Central Main Canal (Imperial Canal) had been built and water began flowing from the Colorado River just south of the U.S.-Mexico border, via the Alamo River, to the canal.

Agricultural development of the sink as a result of irrigation and real estate promotion by Chaffey and the California Development Company exceeded expectations. The population of 2,000 in 1902 grew to 7,000 by 1903 and to more than 10,000 by 1904; and from little or no cultivation in 1900, agriculture in the Salton Sink grew to 120,000 acres under cultivation by January of 1905. During the winter of 1904-1905, greater than usual rainfall in the watershed area of the Gila River caused a high rate of discharge into the Colorado River and resulted in the clogging of canal intake systems with a disproportionate amount of silt. After four floods, the Alamo River-Imperial Canal system overflowed, and the entire discharge of the Colorado River began to pour into the Salton Sink, creating the Salton Sea. Agricultural development resumed in Imperial Valley after the flooding of the Salton Sea was brought under control in early 1907.

With the increasing acreage under irrigation and cultivation, and the Southern Pacific Railroad reaching southward all the way through Imperial and El Centro to Calexico, the population of Imperial Valley and the region surrounding it had grown to around 20,000 by 1907. After prominent Imperial Valley citizens petitioned for Imperial Valley to be separated from the County of San Diego, a vote was held on August 6, 1907; and on August 12, 1907, Imperial County was created. Although Imperial was the first city to be established and incorporated in the region, El Centro was chosen by election to be the county seat later that year.

The IID was established in July 1911 and was the largest irrigation district in the world at that time, covering an area of 817 square miles. In June 1916, the IID purchased the canal system built by the California Development Company. Today, the IID provides water for 6,471 square miles in Imperial Valley and is the most extensive irrigation district in the U.S. Agriculture, dairy farming, and cattle raising have been the economic staples of Imperial Valley since the early twentieth century. Although

the Great Depression of the 1930s brought hardships to the area, it also brought many agricultural workers from the Oklahoma dust bowl who became permanent residents. The completion of Boulder (Hoover) Dam on the Colorado River in 1935, and the All-American Canal from the river to Imperial Valley in 1940, increased and secured the region’s irrigation water supply, solidifying the Imperial Valley’s economy.

Records Search

A records search from the South Coastal Information Center (SCIC) of the CHRIS at San Diego State University was requested on September 15, 2020, to determine the extent of previous surveys within a 1-mile of the project area, and whether previously documented pre-contact or historic-period archaeological sites, architectural resources, or traditional cultural properties exist within this area.

Previous Research

On September 21, 2020, the results from the CHRIS records search revealed that 12 previous cultural resources investigations have been conducted within 1 mile of the project area between 1973 and 2001. Eight previous cultural resources investigations overlap the project area, and the records search indicates that portions of the project area have been previously surveyed as part of a cultural resources technical study. Though portions of the project area were previously surveyed, these surveys took place more than 19 years ago under obsolete standards. The length of time that has passed between the prior surveys and the present necessitated a resurvey of the project area. A list of previous cultural resources investigations of the project area is provided in the Cultural Resources Inventory (Appendix F of this EIR).

Previously Recorded Resources

The CHRIS records search determined that six previously recorded cultural resources are located within 1 mile of the project area. Previously recorded resources comprise two historic-period canals, one historic-period bridge, one international boundary monument, one multicomponent precontact ceramic scatter/historic-period refuse deposit, and one pre-contact temporary camp with habitation debris. One previously recorded resource, an historic-period refuse deposit, is located within the project area. Table 3.6-1 details of all seven previously recorded resources.

Table 3.6-1. Previously Recorded Cultural Resources Within 1-Mile of the Project Area

Site No.	Description	NRHP/CRHR Eligibility	Within Project Area?
CA-IMP-000319	Temporary camp with habitation debris	Not Eligible	No
CA-IMP-007130	All-American Canal	Eligible for listing in the NRHP	No
CA-IMP-007835	East Highline Canal	Not Eligible	No
CA-IMP-008050	Historic-period refuse scatter; Precontact ceramic scatter	Not Eligible	No
None	Bridge #58-140	Not Eligible	No

Table 3.6-1. Previously Recorded Cultural Resources Within 1-Mile of the Project Area

Site No.	Description	NRHP/CRHR Eligibility	Within Project Area?
CA-IMP-008660	Historic-period refuse deposit	Not Eligible	Yes
None	International Border Monument #217	Not Eligible	No

Source: Appendix F of this EIR

The National Register Information System did not list any eligible or listed properties within the project area or one-mile vicinity. Additionally, no resources were identified as listed as California Historical Landmarks and by the OHP. One resource, the All-American Canal, has been previously evaluated as eligible for listing on the NRHP.

A search of historic General Land Office land patent records was also conducted and revealed nine historic-period resources in the project area. Additional details on these nine resources are provided in the Cultural Resources Inventory (Appendix F of this EIR).

Field Survey

Between October 5 and 12, 2020, a pedestrian survey was conducted on the project area under the guidance of the *Secretary of the Interior's Standards for the Identification of Historic Properties*. The pedestrian survey was conducted by walking north-south transects across all accessible portions of the property and examining both permeable and impermeable surfaces throughout. During the survey, exposed ground surfaces were examined for indications of surface or subsurface cultural resources. The general morphological characteristics of the ground surface were inspected for indications of subsurface deposits that may be manifested on the surface, such as circular depressions or ditches.

The entire project area is currently undeveloped. However, large portions of the project area have previously been utilized for agriculture. Additionally, evidence of previous vegetation removal efforts is visible, and the eastern quarter of the project area has been staked out with surveyor's lath. Minimally disturbed native surfaces exist in the western third of the project area. Visible soil is all native soils that are either periodically inundated, undisturbed, or disturbed by agricultural or vegetation removal activities within the project area.

One previously recorded resource was relocated and updated as part of this study and 16 newly identified cultural resources were found during the field survey (Table 3.6-2). Newly identified cultural resources comprise of pre-contact and historic-period resources.



Table 3.6-2. Updated and Newly Recorded Resources within the Project Area

Temporary or Primary No.	Age/Period	Description	NRHP Eligibility	CRHR Eligibility
P-13-009597	Historic	Refuse deposit	NE under all criteria	NE under all criteria
2020-142-001	Historic	Refuse deposit	TE under A, B, D	TE under 1, 2, and 4
2020-142-002	Historic	Refuse deposit	TE under A, B, D	TE under 1, 2, and 4
2020-142-004	Historic	Refuse deposit	TE under A, B, D	TE under 1, 2, and 4
2020-142-005	Pre-contact	Ceramic and lithic scatter	TE under D	TE under 4
2020-142-006-I	Pre-contact	Ceramic isolate	NE under all criteria	NE under all criteria
2020-142-007-I	Pre-contact	Ceramic and lithic isolate	NE under all criteria	NE under all criteria
2020-142-008	Pre-contact	Ceramic and lithic scatter with historic isolates	TE under D	TE under 4
2020-142-017-I	Pre-contact	Ceramic isolate	NE under all criteria	NE under all criteria
2020-142-018-I	Historic	Can isolate	NE under all criteria	NE under all criteria
2020-142-019	Pre-contact	Ceramic and lithic scatter	NE under all criteria	NE under all criteria
2020-142-020-I	Pre-contact	Lithic isolate	NE under all criteria	NE under all criteria
2020-142-021	Historic	Agricultural irrigation equipment	NE under all criteria	NE under all criteria
2020-142-022	Pre-contact	Ceramic and lithic scatter	NE under all criteria	NE under all criteria
2020-142-023-I	Pre-contact	Ceramic isolate	NE under all criteria	NE under all criteria
2020-142-024-I	Pre-contact	Lithic isolate	NE under all criteria	NE under all criteria
2020-142-025	Historic	Agricultural irrigation equipment	NE under all criteria	NE under all criteria

Source: Appendix F of this EIR

Notes: TE = Treated as Eligible; NE = Evaluated and Found Not Eligible

Historical Resources

Historical resources significant under CEQA include those designated or eligible for designation in the NRHP, the CRHR or other state program, or a local register of historical resources. Historical resources may also include resources listed in the State Historic Resources Inventory as significant at the local level or higher, and resources evaluated as potentially significant in a survey or other professional evaluation.

As shown in Table 3.6-2, a total of 17 cultural resources were identified within the project area: five historic-period sites, two pre-contact (prehistoric) sites, three multi-component sites (with pre-contact and historic-period elements), six pre-contact isolates, and one historic-period isolate.

As a result of the inventory and evaluations, out of the 17 total cultural resources identified within the project area, five cultural resources are being treated as eligible for the NRHP as historic properties under Section 106 and eligible for the CRHR as historical resources under CEQA. These five cultural resources are described in detail below, including a discussion of their NRHP and CRHR eligibility considerations. The NRHP and CRHR eligibility criteria are described below.

- **NRHP Eligibility Criteria.** Four criteria have been established to determine if a resource is significant to American history, architecture, archaeology, engineering, or culture and should be listed in the NRHP. These criteria include:
 - A. It is associated with events that have made a significant contribution to the broad patterns of our history;
 - B. It is associated with the lives of persons significant in our past;
 - C. It embodies the distinctive characteristics of a type, period, or method of construction or that represent the work of a master, or that possess high artistic values, or that represent a significant and distinguishable entity whose components may lack individual distinction; and
 - D. It yields, or may be likely to yield, information important in prehistory or history.
- **CRHR Eligibility Criteria.** For the purposes of CEQA review, a historical resource is defined as follows (14 CCR 15064.5[a]):
 1. A resource listed in, or determined eligible by the State Historical Resources Commission for listing in, the California Register of Historical Resources (CRHR)
 2. A resource included in a local register of historical resources
 3. A resource identified as significant in a historical resource survey meeting the requirements specified in PRC 5024.1(g)
 4. Any resource that the lead agency determines to be historically significant

Historic-Period Refuse Scatter: Site 2020-142-001

Site 2020-142-001 consists of historic-period refuse deposits in three distinct concentrations, measuring a total of 44 meters long and 29 meters wide. Within these concentrations, hundreds of glass and metal can fragments, boot heels, and a fragmented license plate were observed. Variations in maker marks within the concentrations suggest bottles were produced in the first half of the 20th century, some before the 1930s.

ELIGIBILITY CONSIDERATION

Archival research may reveal a connection between this site and an important event or person in history. Artifacts onsite suggest that there may be present archaeological deposits that are temporally diagnostic, which may be able to provide important information in history. This site is hereby being treated as eligible for NRHP, without testing, under Criteria A, B and D and for CRHR under Criteria 1, 2, and 4 for the purposes of this project alone.

Historic-Period Refuse Scatter: Site 2020-142-002

Site 2020-142-002 consists of historic-period metal and glass refuse in two concentrations, with additional refuse scattered between and around them measuring a total of 40 meters long and 32 meters wide. Artifacts consist primarily of domestic and personal consumption artifacts, such as miscellaneous metal fragments and cans, and colorless, cobalt, green, milk, amber, aqua, and amethyst glass. Ammunition casings of .45 Colt (also referred to as Long Colt) were observed on and within the vicinity of the site. A diagnostic glass bottle base located between the two concentrations dates to between 1906 and 1914.

Concentration 1 consists of more than 100 miscellaneous metal and can fragments, glass jar/bottle fragments, and glazed historic-period ceramic fragments. Diagnostic bottle bases within this concentration date between 1915 and 1929.

Concentration 2 is a smaller deposit consisting of similar glass and can fragments. A diagnostic bottle base within this concentration dates between 1934 to ca. 1968.

ELIGIBILITY CONSIDERATION

Archival research may reveal a connection between this site and an important event or person in history. Artifacts onsite suggest that there may be present archaeological deposits that are temporally diagnostic, which may be able to provide important information in history. This site is hereby being treated as eligible for NRHP, without testing, under Criteria A, B, and D and for CRHR under Criteria 1, 2 and 4 for the purposes of this project alone.

Historic-Period Refuse Scatter: Site 2020-142-004

Site 2020-142-004 consists of a single historic-period refuse deposit measuring 16 meters long by 12 meters wide. The site includes miscellaneous metals (non-diagnostic), glazed ceramics, approximately 75 crockery fragments, and fragments of various glass colors including at least 50 aqua, five green, over 150 colorless, 20 sun-colored amethyst, five cobalt, and two milk glass. Miscellaneous metals include .45 Colt casings and a brass belt buckle.

ELIGIBILITY CONSIDERATION

Archival research may reveal a connection between this site and an important event or person in history. Artifacts onsite suggest that there may be present archaeological deposits that are temporally diagnostic, which may be able to provide important information in history. This site is hereby being treated as eligible for NRHP, without testing, under Criteria A, B and D and for CRHR under Criteria 1, 2 and 4 for the purposes of this project alone.

Pre-Contact Ceramic and Lithic Scatter: Site 2020-142-005

Site 2020-142-005 consists of a pre-contact artifact scatter comprised of ceramic fragments, one lithic fragment, and one isolated historic-period glass bottle base, measuring 65 meters long by 65 meters

wide. Over 100 sherds of precontact ceramics were counted, three of which were rim sherds, including Greyware, buff, Tizon brown ware, and redware.

ELIGIBILITY CONSIDERATION

Several of the ceramic artifacts at this site may have temporally diagnostic markers that can be associated with a specific event or pattern of events marking an important moment in pre-contact history. This site is hereby treated as eligible for NRHP, without testing, under Criterion D and CRHR under Criterion 4 for the purposes of this project alone.

Pre-Contact Ceramic and Lithic Scatter and Historic-Period Isolate: Site 2020-142-008

This pre-contact site consists of six discrete concentrations (Concentration 1 through Concentration 6) of ceramic scatter and several lithic artifacts, located along a westward-facing terrace above the 11.9-meter (40-foot) elevation eastern shore of Lake Cahuilla. An approximate total of 300 ceramic sherds and 10 fragments of lithic debitage are present within this site. An isolated historic-period .30-06 cartridge case manufactured in the Twin Cities Ordnance Plant in 1942 was also identified within the site boundary. Overall, the site size measures 290 meters long and 105 meters wide.

ELIGIBILITY CONSIDERATION

Several of the ceramic artifacts at this site may have temporally diagnostic markers that can be associated with a specific event or pattern of events marking an important moment in pre-contact history. This site is hereby treated as eligible for NRHP, without testing, under Criterion D and CRHR under Criterion 4 for the purposes of this project alone.

3.6.2 Regulatory Setting

This section identifies and summarizes federal, state, and local laws, policies, and regulations that are applicable to the project.

Federal

National Historic Preservation Act

Federal regulations (36 CFR Part 800.2) define historic properties as "any prehistoric or historic district, site, building, structure, or object included, or eligible for inclusion in, in the National Register of Historic Places." Section 106 of the National Historic Preservation Act (NHPA) (Public Law 89-665; 80 Stat 915; USC 470, as amended) requires a federal agency with jurisdiction over a project to take into account the effect of the project on properties included in or eligible for the (NRHP, and to afford the Advisory Council on Historic Preservation a reasonable opportunity to comment. The term "cultural resource" is used to denote a historic or prehistoric district, site, building, structure, or object, regardless of whether it is eligible for the NRHP.

State

California Office of Historic Preservation

The California Office of Historic Preservation (OHP) administers state and federal historic preservation programs and provides technical assistance to federal, state, and local government agencies, organizations, and the general public with regard to historic preservation programs designed to identify, evaluate, register, and protect California's historic resources.



Section 15064.5 of the CEQA Guidelines also requires that Native American concerns and the concerns of other interested persons and corporate entities, including but not limited to museums, historical commissions, associations, and societies be solicited as part of the process of cultural resources inventory. In addition, California law protects Native American burials, skeletal remains, and associated grave goods regardless of their antiquity and provides for the sensitive treatment and disposition of those remains (HSC Section 7050.5, PRC Sections 5097.94 et seq.).

CEQA Guidelines: Historical Resources Definition

CEQA Guidelines Section 15064.5(a) defines a historical resource as:

- (1) A resource listed in, or determined to be eligible by the State Historical Resources Commission, for listing in the CRHR (PRC Section 5024.1; Title 14 CCR, Section 4850 et seq.).
- (2) A resource included in a local register of historical resources, as defined in Section 5020.1(k) of the Public Resources Code or identified as significant in an historical resource survey meeting the requirements Section 5024.1(g) of the Public Resources Code, shall be presumed to be historically or culturally significant. Public agencies must treat any such resource as significant unless the preponderance of evidence demonstrates that it is not historically or culturally significant.
- (3) Any object, building, structure, site, area, place, record, or manuscript which a lead agency determines to be historically significant or significant in the architectural, engineering, scientific, economic, agricultural, educational, social, political, military, or cultural annals of California may be considered to be an historical resource, provided the lead agency's determination is supported by substantial evidence in light of the whole record. Generally, a resource shall be considered by the lead agency to be "historically significant" if the resource meets the criteria for listing on the CRHR (PRC Section 5024.1; Title 14 CCR, Section 4852) including the following:
 - (A) Is associated with events that have made a significant contribution to the broad patterns of California's history and cultural heritage;
 - (B) Is associated with the lives of persons important to our past;
 - (C) Embodies the distinctive characteristics of a type, period, region, or method of construction, or represents the work of an important creative individual, or possesses high artistic values; or
 - (D) Has yielded, or may be likely to yield, information important in prehistory or history.¹
- (4) The fact that a resource is not listed in, or determined to be eligible for listing in the CRHR, not included in a local register of historical resources (pursuant to Section 5020.1(k) of the Public Resources Code), or identified in an historical resources survey (meeting the criteria in Section 5024.1(g) of the Public Resources Code) does not preclude a lead agency from determining that the resource may be an historical resource as defined in Public Resources Code Sections 5020.1(j) or 5024.1.

¹ Ibid.

CEQA Guidelines: Archaeological Resources

Section 15064.5(c) of CEQA Guidelines provides specific guidance on the treatment of archaeological resources as noted below.

- (1) When a project will impact an archaeological site, a lead agency shall first determine whether the site is an historical resource, as defined in subdivision (a).
- (2) If a lead agency determines that the archaeological site is an historical resource, it shall refer to the provisions of Section 21084.1 of the Public Resources Code, and this section, Section 15126.4 of the Guidelines, and the limits contained in Section 21083.2 of the Public Resources Code do not apply.
- (3) If an archaeological site does not meet the criteria defined in subdivision (a), but does meet the definition of a unique archeological resource in Section 21083.2 of the Public Resources Code, the site shall be treated in accordance with the provisions of Section 21083.2. The time and cost limitations described in Public Resources Code Section 21083.2 (c–f) do not apply to surveys and site evaluation activities intended to determine whether the project location contains unique archaeological resources.
- (4) If an archaeological resource is neither a unique archaeological nor an historical resource, the effects of the project on those resources shall not be considered a significant effect on the environment. It shall be sufficient that both the resource and the effect on it are noted in the Initial Study or EIR, if one is prepared to address impacts on other resources, but they need not be considered further in the CEQA process.

CEQA Guidelines: Human Remains

Section 15064.5 of CEQA Guidelines provides specific guidance on the treatment of human remains pursuant to PRC § 5097.98, which provides specific guidance on the disposition of Native American burials (human remains), and fall within the jurisdiction of the NAHC:

- (d) When an initial study identifies the existence of, or the probable likelihood, of Native American human remains within the project, a lead agency shall work with the appropriate Native Americans as identified by the NAHC as provided in Public Resources Code Section 5097.98. The applicant may develop an agreement for treating or disposing of, with appropriate dignity, the human remains and any items associated with Native American burials with the appropriate Native Americans as identified by the NAHC. Action implementing such an agreement is exempt from:
 - (1) The general prohibition on disinterring, disturbing, or removing human remains from any location other than a dedicated cemetery (HSC Section 7050.5).
 - (2) The requirements of CEQA and the Coastal Act.
- (e) In the event of the accidental discovery or recognition of any human remains in any location other than a dedicated cemetery, the following steps should be taken:
 - (1) There shall be no further excavation or disturbance of the site or any nearby area reasonably suspected to overlie adjacent human remains until:
 - (A) The coroner or the county in which the remains are discovered must be contacted to determine that no investigation of the cause of death is required, and
 - (B) If the coroner determines the remains to be Native American:

1. The coroner shall contact the NAHC within 24 hours.
 2. The NAHC shall identify the person or persons it believes to be the most likely descended from the deceased Native American.
 3. The mostly descendent may make recommendations to the landowner of the person responsible for the excavation work, for means of treating or disposing of, with appropriate dignity, the human remains and any associated grave goods as provided in Public Resources Code section 5097.98, or
- (2) Where the following conclusions occur the landowner or his authorized representative shall rebury the Native American human remains and associated grave goods with appropriate dignity on the property in a location not subject to further subsurface disturbance.
- (A) The NAHC is unable to identify a most likely descendent or the most likely descendent failed to make a recommendation within 24 hours after being notified by the commission.
- (B) The descendant fails to make a recommendation; or
- (C) The landowner or his authorized representative rejects the recommendation of the descendant, and the mediation by the NAHC fails to provide measures acceptable to the landowner.
- (f) As part of the objectives, criteria, and procedures required by Section 21082 of the Public Resources Code, a lead agency should make provisions for historical or unique archaeological resources accidentally discovered during construction. These provisions should include an immediate evaluation of the find by a qualified archaeologist. If the find is determined to be an historical or unique archaeological resource, contingency funding and a time allotment sufficient to allow for implementation of avoidance measures or appropriate mitigation should be available. Work could continue on other parts of the building site while historical or unique archaeological resource mitigation takes place.”

California Health and Safety Code, Section 7050.5

California HSC 7050.5 makes it a misdemeanor to disturb or remove human remains found outside a cemetery. This code also requires a project owner to halt construction if human remains are discovered and to contact the County Coroner.

Local

Imperial County General Plan

The Imperial County General Plan provides goals, objectives, and policies for the identification and protection of significant cultural resources. The Conservation and Open Space Element of the General Plan includes goals, objectives, and policies for the protection of cultural resources and scientific sites that emphasize identification, documentation, and protection of cultural resources. While Section 3.11, Land Use Planning, of this EIR analyzes the project’s consistency with the General Plan pursuant to CEQA Guidelines Section 15125(d), the Imperial County Board of Supervisors and Planning Commission ultimately make a determination as to the project’s consistency with the General Plan. Goals and Objectives applicable to the proposed project are summarized in Table 3.6-3.

Table 3.6-3. Project Consistency with Applicable General Plan Goals and Objectives

General Plan Policies	Consistency with General Plan	Analysis
<p>Conservation and Open Space Element - <i>Open Space and Recreation Conservation</i></p> <p>Goal 1 - Environmental resources shall be conserved for future generations by minimizing environmental impacts in all land use decisions and educating the public on their value.</p> <p>Objective 1.4 - Ensure the conservation and management of the County's natural and cultural resources.</p>	Consistent	<p>A cultural resources inventory was prepared for the project area. Known archaeological resources within the project area will be avoided and not impacted. However, as discussed below, the proposed project has the potential to encounter undocumented historical, archaeological resources, and human remains.</p> <p>Implementation of Mitigation Measure CR-1 would ensure avoidance of five historical resources on the project site. With implementation of Mitigation Measure CR-2, potential impacts to previously unrecorded cultural resources would be reduced to a level less than significant. Implementation of Mitigation Measure CR-3 would reduce the potential impact associated with the inadvertent discovery of archaeological resources to a level less than significant. Mitigation Measure CR-4 would ensure that the potential impact on previously unknown human remains does not rise to the level of significance pursuant to CEQA.</p>
<p>Objective 3.1 - Protect and preserve sites of archaeological, ecological, historical, and scientific value, and/or cultural significance.</p>	Consistent	<p>Implementation of Mitigation Measure CR-1 would ensure avoidance of five historical resources on the project site. With implementation of Mitigation Measure CR-2, potential impacts to previously unrecorded cultural resources would be reduced to a level less than significant. Implementation of Mitigation Measure CR-3 would reduce the potential impact associated with the inadvertent discovery of archaeological resources to a level less than significant. Mitigation Measure CR-4 would ensure that the potential impact on previously unknown human remains does not rise to the level of significance pursuant to CEQA.</p>

Source: County of Imperial 1993

Notes:

CR=cultural resource

3.6.3 Impacts and Mitigation Measures

This section presents the significance criteria used for considering proposed project impacts related to cultural and archeological resources, the methodology employed for the evaluation, an impact evaluation, and mitigation requirements, if necessary.

Thresholds of Significance

Based on CEQA Guidelines Appendix G, project impacts related to cultural resources are considered significant if any of the following occur:

- Cause a substantial adverse change in the significance of a historical resource pursuant to §15064.5
- Cause a substantial adverse change in the significance of an archaeological resource pursuant to §15064.5
- Disturb any human remains, including those interred outside of dedicated cemeteries

Methodology

This analysis evaluates the potential for the proposed project, as described in Chapter 2, Project Description, to interact with cultural resources in the project area. Based on the extent of these interactions, this analysis considers whether these conditions would result in an exceedance of one or more of the applied significance criteria as identified above.

As indicated in the environmental setting, a Cultural Resources Inventory (Appendix F of this EIR) was prepared for the project. The cultural resources inventory provides the results of a SCIC records search and a field survey which have been completed for the project area pursuant to CEQA.

The information from the cultural resources inventory was reviewed and summarized to present the existing conditions and to identify potential environmental impacts, based on the significance criteria presented in this section. Impacts associated with cultural resources that could result from project construction and operational activities were evaluated qualitatively based on site conditions; expected construction practices; materials, locations, and duration of project construction and related activities.

Impact Analysis

Impact 3.6-1 Would the project cause a substantial adverse change in the significance of a historical resource pursuant to §15064.5?

To be considered historically significant, a resource must meet one of four criteria for listing outlined in the CRHR (CEQA Guidelines 15064.3 (a)(3)). In addition to meeting one of the criteria outlined the CRHR, a resource must retain enough intact and undisturbed deposits to make a meaningful data contribution to regional research issues (CCR Title 14, Chapter 1.5 Section 4852 [c]). Further, based on CEQA Guidelines Section 15064.5 (b), substantial adverse change would include physical demolition, destruction, relocation, or alteration of the resource or its immediate surroundings such that the significance of an historical resource is materially impaired. This can occur when a project:

- Demolishes or materially alters in an adverse manner those physical characteristics of an historical resource that convey its historical significance and that justify its inclusion in, or eligibility for, inclusion in the CRHR, NRHP, a local register, or historic resources.
- Demolishes or materially alters in an adverse manner those physical characteristics that account for its identification in an historical resources survey meeting the requirements of PRC §5024.1(g), unless the public agency establishes by a preponderance of the evidence that the resource is not historically or culturally significant.

SOLAR ENERGY FACILITY, BATTERY STORAGE SYSTEM, AND GEN-TIE LINE

As a result of the inventory and evaluations, out of the 17 total cultural resources identified within the project area, the following five cultural resources are being treated as eligible for listing in the CRHR as historical resources under CEQA.

- Historic-Period Refuse Scatter: Site 2020-142-001 (CRHR Criteria 1, 2, and 4)
- Historic-Period Refuse Scatter: Site 2020-142-002 (CRHR Criteria 1, 2, and 4)
- Historic-Period Refuse Scatter: Site 2020-142-004 (CRHR Criteria 1, 2, and 4)
- Pre-Contact Ceramic and Lithic Scatter: Site 2020-142-005 (CRHR Criterion 4)
- Pre-Contact Ceramic and Lithic Scatter and Historic-Period Isolate: Site 2020-142-008 (CRHR Criterion 4)

The proposed project has been designed to avoid Sites 2020-142-001, 2020-142-002, 2020-142-004, 2020-142-005, and 2020-142-008. To ensure avoidance of Sites 2020-142-001, 2020-142-002, 2020-142-004, 2020-142-005, and 2020-142-008, Mitigation Measure CR-1 will be implemented. Mitigation Measure CR-1 requires the installation of orange environmentally sensitive area (ESA) fencing or flagging around the boundaries of each of the resources prior to any construction activity and shall

remain in place throughout project construction. The placement of the ESA flagging or fencing will be done under the supervision of a qualified archaeologist (to be retained by the project applicant). No project activity (including equipment staging, transportation, vegetation removal, or construction or other crews standing or walking) shall occur within the ESA boundaries of the sites. Implementation of Mitigation Measure CR-1 would reduce impacts on historical resources to a level less than significant.

Given the number of resources identified within the project area, there is a potential to unearth previously unknown cultural resources. In the event that unknown cultural resources are discovered during project construction, significant impacts could occur. However, with implementation of Mitigation Measure CR-2, potential impacts to previously unrecorded cultural resources would be reduced to a level less than significant.

ACCESS ROAD

During construction, vendors and heavy construction equipment would access the project site via Gordon Wells Road approximately 20 miles east of the project site, then travel west along an existing dirt road paralleling the U.S./Mexico Border. This existing dirt road is actively used by the U.S. Border Patrol during patrol operations. The use of this access road during construction is not anticipated to result in potential impacts on cultural resources because vehicles and construction equipment would be required to stay within the existing boundaries of the dirt road to avoid and/or minimize ground disturbance to undisturbed and vegetated areas. Furthermore, the project applicant would not make improvements to the existing dirt road except for the application of water for dust suppression. No grading or excavation would occur to the dirt road as a result of the project. Based on these considerations, the potential to impact cultural resources is considered low and a less than significant impact would occur.

Mitigation Measure(s)

CR-1 Environmentally Sensitive Area Fencing. Prior to issuance of grading permits and in coordination with a qualified archaeologist to be retained by the project applicant, the construction zone shall be narrowed or otherwise altered to avoid Sites 2020-142-001, 2020-142-002, 2020-142-004, 2020-142-005, and 2020-142-008. The area within 100 feet of Sites 2020-142-001, 2020-142-002, 2020-142-004, 2020-142-005, and 2020-142-008 shall be designated Environmentally Sensitive Area (ESA) and fenced or flagged with exclusion markers to ensure avoidance. Protective fencing shall not identify the protected area as a cultural resource area in order to discourage unauthorized disturbance or collection of artifacts. The ESA fencing or flags shall remain in place throughout project construction.

CR-2 Evaluate Significance of Find (Unknown Cultural Resources). If subsurface deposits believed to be cultural in origin are discovered during construction, all work must halt within a 100-foot radius of the discovery. A qualified professional archaeologist who meets the Secretary of the Interior's Standards for prehistoric and historic archaeology and is familiar with the resources of the region, shall be retained to evaluate the significance of the find, and shall have the authority to modify the no work radius as appropriate, using professional judgment. The following notifications shall apply, depending on the nature of the find:

- If the professional archaeologist determines that the find does not represent a cultural resource, work may resume immediately, and no agency notifications are required.
- If the professional archaeologist determines that the find does represent a cultural resource from any time period or cultural affiliation, he or she shall immediately notify

the Imperial County Planning and Development Services Department. The Imperial County Planning and Development Services Department shall consult with the professional archaeologist on a finding of eligibility and implement appropriate treatment measures if the find is determined to be an Historical Resource under CEQA, as defined in Section 15064.5(a) of the CEQA Guidelines, or an Historic Property, as defined in 36 CFR 60.4. Work may not resume within the no-work radius until the Imperial County Planning and Development Services Department, through consultation as appropriate, determine that the site either: 1) is not an Historical Resource under CEQA or an Historic Property under Section 106; or 2) that the treatment measures have been completed to their satisfaction.

Impact 3.6-2 Would the project cause a substantial adverse change in the significance of an archaeological resource pursuant to §15064.5?

Pursuant to CEQA Guidelines §15064.5(c)(1) and (2), an archaeological resource includes an archaeological site that qualifies as a significant historical resource as described for Impact 3.6-1. If an archaeological site does not meet any of the criteria outlined in the provisions under Impact 3.6-1 but meets the definition of a “unique archaeological resource” in PRC 21083.2, the site shall be treated in accordance with the provisions of PRC 21083.2, unless the project applicant and public agency elect to comply with all other applicable provisions of CEQA with regards to archaeological resources. “Unique archaeological resource” means an archaeological artifact, object or site about which it can be clearly demonstrated that, without merely adding to the current body of knowledge, there is a high probability that it meets any of the following criteria:

- 1) Contains information needed to answer important scientific research questions that there is a demonstrable public interest in that information.
- 2) Has a special and particular quality such as being the oldest of its type or the best available example of its type.
- 3) Is directly associated with a scientifically recognized important historic event or person.

CEQA Guidelines 15064.5(c)(4) confirms that if an archaeological resource is neither a unique archaeological nor an historic resource, the effects of the project on those resources shall not be considered a significant effect on the environment.

SOLAR ENERGY FACILITY, BATTERY STORAGE SYSTEM, AND GEN-TIE LINE

Based on a review of historic aerial photographs and maps of the project area, the property was in use as agricultural land as early as 1953. Portions of the project area appear to have been used for agricultural purposes at varying times in photographs from 1953 to 1996. The property has undergone agricultural modification, tilling, and grading in past decades. These agricultural activities have likely heavily disturbed the surface and subsurface of the project area, destroying any intact potential prehistoric or historic-era cultural resources. The potential of finding a buried archaeological site during construction is considered low. However, like all construction projects in the state, the possibility exists. This potential impact is considered significant. Implementation of Mitigation Measure CR-3 would reduce the potential impact associated with the inadvertent discovery of archaeological resources to a level less than significant.

ACCESS ROAD

During construction, vendors and heavy construction equipment would access the project site via Gordon Wells Road approximately 20 miles east of the project site, then travel west along an existing

dirt road paralleling the U.S./Mexico Border. This existing dirt road is actively used by the U.S. Border Patrol during patrol operations. The use of this access road during construction is not anticipated to result in potential impacts on archaeological resources because vehicles and construction equipment would be required to stay within the existing boundaries of the dirt road to avoid and/or minimize ground disturbance to undisturbed and vegetated areas. Furthermore, the project applicant would not make improvements to the existing dirt road except for the application of water for dust suppression. No grading or excavation would occur to the dirt road as a result of the project. Based on these considerations, the potential to impact archaeological resources is considered low and a less than significant impact would occur.

Mitigation Measure(s)

CR-3 Evaluate Significance of Find (Unknown Archaeological Resources). In the event of the discovery of previously unidentified archaeological materials, the contractor shall immediately cease all work activities within approximately 100 feet of the discovery. After cessation of excavation, the contractor shall immediately contact the Imperial County Department of Planning and Development Services Department. Except in the case of cultural items that fall within the scope of the Native American Grave Protection and Repatriation Act, the discovery of any cultural resource within the project area shall not be grounds for a “stop work” notice or otherwise interfere with the project’s continuation except as set forth in this paragraph.

In the event of an unanticipated discovery of archaeological materials during construction, the applicant shall retain the services of a qualified professional archaeologist, meeting the Secretary of the Interior’s Standards for a Qualified Archaeologist, to evaluate the significance of the materials prior to resuming any construction-related activities in the vicinity of the find. If the qualified archaeologist determines that the discovery constitutes a significant resource under CEQA and it cannot be avoided, the applicant shall implement an archaeological data recovery program.

Impact 3.6-3 Would the project disturb any human remains, including those interred outside of dedicated cemeteries?

SOLAR ENERGY FACILITY, BATTERY STORAGE SYSTEM, AND GEN-TIE LINE

During the construction and operational phases of the proposed project, grading, excavation and trenching will be required. Although the potential for encountering subsurface human remains within the project site is low, there remains a possibility that human remains are present beneath the ground surface, and that such remains could be exposed during construction. The potential to encounter human remains is considered a significant impact. Mitigation Measure CR-4 would ensure that the potential impact on previously unknown human remains does not rise to the level of significance pursuant to CEQA.

ACCESS ROAD

During construction, vendors and heavy construction equipment would access the project site via Gordon Wells Road approximately 20 miles east of the project site, then travel west along an existing dirt road paralleling the U.S./Mexico Border. This existing dirt road is actively used by the U.S. Border Patrol during patrol operations. The use of this access road during construction is not anticipated to result in potential impacts on archaeological resources because vehicles and construction equipment would be required to stay within the existing boundaries of the dirt road to avoid and/or minimize ground disturbance to undisturbed and vegetated areas. Furthermore, the project applicant would not

make improvements to the existing dirt road except for the application of water for dust suppression. No grading or excavation would occur to the dirt road as a result of the project. Based on these considerations, the potential to encounter human remains is considered low and a less than significant impact would occur.

Mitigation Measure(s)

CR-4 Human Remains. If subsurface deposits believed to be human in origin are discovered during construction, all work must halt within a 100-foot radius of the discovery. A qualified professional archaeologist who meets the Secretary of the Interior’s Standards for prehistoric and historic archaeology and is familiar with the resources of the region, shall be retained to evaluate the significance of the find, and shall have the authority to modify the no work radius as appropriate, using professional judgment. The following notifications shall apply, depending on the nature of the find:

- If the find includes human remains, or remains that are potentially human, the professional archaeologist shall ensure reasonable protection measures are taken to protect the discovery from disturbance (AB 2641). The archaeologist shall notify the Imperial County Coroner (per § 7050.5 of the Health and Safety Code). The provisions of § 7050.5 of the California Health and Safety Code, § 5097.98 of the California PRC, and AB 2641 will be implemented.
- If the Coroner determines the remains are Native American and not the result of a crime scene, the Coroner will notify the NAHC, which then will designate a Native American Most Likely Descendant (MLD) for the project (§ 5097.98 of the PRC). The designated MLD will have 48 hours from the time access to the property is granted to make recommendations concerning treatment of the remains. If the landowner does not agree with the recommendations of the MLD, the NAHC may mediate (§ 5097.94 of the PRC). If no agreement is reached, the landowner must rebury the remains where they will not be further disturbed (§ 5097.98 of the PRC). This will also include either recording the site with the NAHC or the appropriate Information Center; using an open space or conservation zoning designation or easement; or recording a reinternment document with the county in which the property is located (AB 2641). Work may not resume within the no-work radius until the Imperial County Planning and Development Services Department, through consultation as appropriate, determine that the treatment measures have been completed to their satisfaction.

3.6.4 Decommissioning/Restoration and Residual Impacts

Decommissioning/Restoration

No impact is anticipated from restoration activities as the ground disturbance and associated impacts on cultural resources will have occurred during the construction phase of the proposed project.

Residual

Implementation of Mitigation Measure CR-1 would reduce potential impacts on historical resources to a level less than significant. With implementation of Mitigation Measure CR-2, potential impacts to previously unrecorded cultural resources would be reduced to a level less than significant. Implementation of Mitigation Measure CR-3 would reduce the potential impact associated with the

inadvertent discovery of archaeological resources to a level less than significant. Mitigation Measure CR-4 would ensure that the potential impact on previously unknown human remains does not rise to the level of significance pursuant to CEQA. No unmitigable impacts on cultural resources would occur with implementation of the proposed project.

3.7 Geology and Soils

This section includes an evaluation of the project in relation to existing geologic and soils conditions within the project site. Information contained in this section is summarized from the Preliminary Geological and Geotechnical Hazard Evaluation Report prepared by HDR. This report is included as Appendix G of this EIR.

3.7.1 Existing Conditions

Regional Geology

The project site is located in Imperial County in the Salton Trough portion of the Colorado Desert physiographic province. The Salton Trough is a topographic and geologic structural depression resulting from large scale regional faulting. The trough is bounded on the east and northeast by the San Andreas Fault and of the west by the San Jacinto Fault Zone. The Salton Trough represents the northward extension of the Gulf of California and contains more than 15,000 feet of Miocene and younger, marine and non-marine sediments capped by approximately 100 feet of Pleistocene and later lacustrine deposits as a result of intermittent filling derived from periodic flooding of the Colorado River and Lake Cahuilla (Appendix G of this EIR). Tectonic activity that formed the trough continues at a high rate as evidenced by deformed young sedimentary deposits and high levels of seismicity.

The geologic conditions present within the County contribute to a wide variety of hazards that can result in loss of life, bodily injury, and property damage. The primary seismic hazard at the project site is the potential for strong ground shaking. The project site is located within a highly active seismic zone. The nearest active major fault that poses a risk contribution of greater than 1 percent is the Imperial Fault, located approximately 2.36 miles (3.8 kilometers) west of the project site.

Surface Subgrade Soils and Groundwater Conditions

The project site is generally underlain by stratified alluvial deposits, predominately consisting of interbedded layers of silt, sand, and clay. The near-surface soils are predominantly comprised of very fine to fine sand and occasionally clay and silty clay (Appendix G of this EIR). As shown on Figure 3.7-1, soil series mapped on the project site include:

- 102 – Badland
- 119 – Indio-Vint complex
- 126 – Niland fine sand
- 131 – Rositas sand, 2 to 5 percent slope
- 132 – Rositas fine sand, 0 to 2 percent slopes
- 135 – Rositas fine sand, wet, 0 to 3 percent slopes
- 136 – Rositas loamy fine sand, 0 to 3 percent slopes
- 142 – Vint loamy very fine sand, wet

There are no known groundwater wells within a one-mile radius of the project site (Appendix G of this EIR).

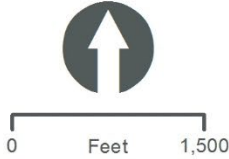
This page is intentionally blank.

Figure 3.7-1. Soils Mapped on the Project Site



Legend

- Project Boundary
- 102 - Badland
- 119 - Indio-Vint complex
- 126 - Niland fine sand
- 131 - Rositas sand, 2 to 5 percent slopes
- 132 - Rositas fine sand, 0 to 2 percent slopes
- 135 - Rositas fine sand, wet, 0 to 2 percent slopes
- 136 - Rositas loamy fine sand, 0 to 2 percent slopes
- 142 - Vint loamy very fine sand, wet



This page is intentionally blank



Faulting and Seismicity

Earthquakes are the result of an abrupt release of energy stored in the earth. This energy is generated from the forces which cause the continents to change their relative position on the earth's surface, a process called "continental drift." The earth's outer shell is composed of a number of relatively rigid plates which move slowly over the comparatively fluid molten layer below. The boundaries between plates are where the more active geologic processes take place. Earthquakes are an incidental product of these processes.

Southern California straddles the boundary between two global tectonic plates known as the North American Plate (on the east) and the Pacific Plate (on the west). The main plate boundary is represented by the San Andreas Fault, which extends northwest from the Gulf of California in Mexico, through the desert region of the Imperial Valley, through the San Bernardino region, and into Northern California, where it eventually trends offshore, north of San Francisco (Appendix G of this EIR).

In Southern California, the plate boundary is a complex system of numerous faults known as the San Andreas Fault System that spans a 150-mile-wide zone from the main San Andreas fault in the Imperial Valley westward to offshore of San Diego (Appendix G of this EIR).

The project site is located in the seismically active Southern California region, with numerous mapped faults traversing the region including the San Andreas, San Jacinto, and Elsinore Fault Zones. Under the current understanding of regional seismology and tectonics, the largest maximum earthquake to impact the project site would most likely be generated by the Imperial Fault (fault strand 5), which has an estimated maximum magnitude (M) of 7.3. Table 3.7-1 lists faults with a risk contribution greater than 1 percent at the project site (Appendix G of this EIR). Figure 3.7-2 identifies faults within the project region.

Table 3.7-1. Faults with a Risk Contribution of Greater than One Percent

Fault Name	Approximate Distance from Project Site (km)	Maximum Magnitude (M)
Imperial Fault [5]	3.8	7.3
Imperial Fault [6]	5.9	7.0
Imperial Fault [7]	10.4	6.9

Source: Appendix G of this EIR

Notes:

km=kilometers; M=Maximum magnitude; [] Fault strand

Seismic Ground Shaking

Ground shaking is the byproduct of an earthquake and is the energy created as rocks break and slip along a fault during an earthquake. The amount of ground shaking that an area may be subject to during an earthquake is related to the proximity of the area to the fault, the depth of the hypocenter (focal depth), location of the epicenter and the size (magnitude) of the earthquake. Soil type also plays a role in the intensity of shaking. Bedrock or other dense or consolidated materials are less prone to intense ground shaking than soils formed from alluvial deposition.

As the project site is located in the seismically active southern California region, strong ground shaking can be expected at the project site during moderate to severe earthquakes in the general region.

Surface Rupture

Surface rupture occurs when movement along a fault results in actual cracking or breaking of the ground along a fault during an earthquake; however, it is important to note that not all earthquakes result in surface rupture. Surface rupture almost always follows preexisting fault traces, which are zones of weakness. Rupture may occur suddenly during an earthquake or slowly in the form of fault creep. Fault creep is the slow rupture of the earth's crust. Sudden displacements are more damaging to structures because they are accompanied by shaking.

The California Geologic Survey (CGS) established criteria for faults as active, potentially active, and inactive. Active faults are those that show evidence of surface displacement within the last 11,000 years (Holocene age). Potentially active faults are those that demonstrate displacement within the past 1.6 million years (Quaternary age). Faults showing no evidence of displacement within the last 1.6 million years may be, in general, considered inactive for most structures, except for critical structures (Appendix G of this EIR).

In 1972 the Alquist-Priolo Special Studies Earthquake Hazards Act (APEHA) was passed, which required fault studies within 500 feet of active or potentially active faults. The APEHA designates "active" and "potentially active" faults utilizing the same age criteria as that used by the CGS. The project site is not located within a currently mapped APEHA zone. As previously mentioned above, the nearest active major fault is the Imperial fault located approximately 2.3 miles west of the project site (Appendix G of this EIR). Based on this distance, the potential for surface fault rupture to occur on the project site is considered low.

Liquefaction

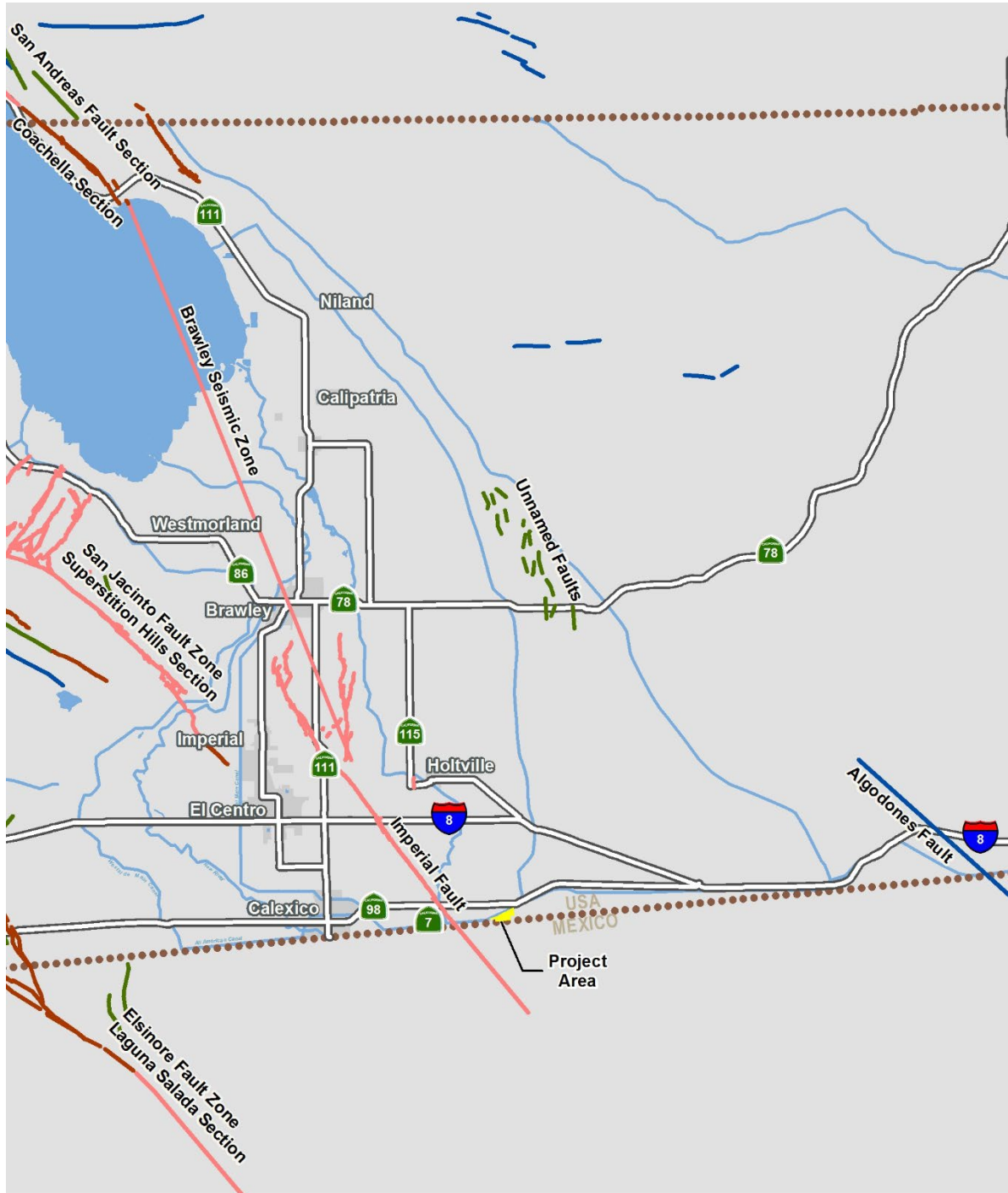
Liquefaction occurs when granular soil below the water table is subjected to vibratory motions, such as those produced by earthquakes. With strong ground shaking, an increase in pore water pressure develops as the soil tends to reduce in volume. If the increase in pore water pressure is sufficient to reduce the vertical effective stress (suspending the soil particles in water), the soil strength decreases, and the soil behaves as a liquid (similar to quicksand). The factors known to influence liquefaction potential include soil type, relative density, grain size distribution, confining pressure, depth to groundwater, and the intensity and duration of the seismic ground shaking. Liquefaction is most prevalent in loose- to medium-dense, silty, sandy, and gravelly soils below the groundwater table.

The project site has not been mapped for liquefaction potential by CGS (Appendix G of this EIR).

Landslides

Landslides are the descent of rock or debris caused by natural factors, such as the pull of gravity, fractured or weak bedrock, heavy rainfall, erosion, and earthquakes. The project site is relatively flat. Due to the existing topography, landslides are not considered a potential hazard for the project (Appendix G of this EIR).

Figure 3.7-2. Regional Fault Map



Legend

- VEGA SES 4 Project Area
- QT - Faults with undivided Quaternary displacement (last 1.6 million years)
- LTQT - Faults with late Quaternary displacement (last 750,000 years)
- HOL - Faults with Holocene displacement (last 11,000 years)
- HIS - Faults with historic displacement (last 200 years)



Lateral Spreading

Lateral spreading typically occurs as a form of horizontal displacement of relatively flat lying alluvial material toward an open or “free” face such as an open body of water, channel, or excavation. This movement is generally due to failure along a weak plane, and may often be associated with liquefaction. As cracks develop within the weakened material, blocks of soil displace laterally toward the open face. Cracking and lateral movement may gradually propagate away from the face as blocks continue to break free. It is unknown whether lateral spreading is a potential hazard on the project site.

Land Subsidence

Land subsidence is the sinking of the ground surface caused by the compression of earth materials or the loss of subsurface soil because of underground mining, tunneling, or erosion. The major causes of subsidence include fluid withdrawal from the ground, decomposing organics, underground mining or tunneling, and placing large fills over compressible earth materials. The effective stress on underlying soils is increased resulting in consolidation and settlement. Subsidence may also be caused by tectonic processes.

The project site is not located in an area of known ground subsidence or within any delineated zones of subsidence due to groundwater pumping or oil extraction. As such, the potential for subsidence at the project site is considered low (Appendix G of this EIR).

Expansive Soils

Expansive soils are characterized by their ability to undergo significant volume changes (shrink or swell) due to variations in moisture content. Changes in soil moisture content can result from precipitation, landscape irrigation, utility leakage, roof drainage, perched groundwater, drought, or other factors and may result in unacceptable settlement or heave of structures. The project site is underlain by sand, gravelly sand and clay/silty clay. Generally, sands are considered not expansive while soils and clays may exhibit moderate to high expansion potential due to variation in moisture content (Appendix G of this EIR).

Collapsible Soils

Collapsible soil is generally defined as soil that will undergo a sudden decrease in volume and its internal support is lost under applied loads when water is introduced into the soil. The internal support is considered to be a temporary strength and is derived from a number of sources including capillary tension, cementing agents, e.g. iron oxide and calcium carbonate, clay-welding of grains, silt bonds, clay bonds and clay bridges. Soils found to be most susceptible to collapse include loess (fine grained wind-deposited soils), valley alluvium deposited within a semi-arid to arid climate, and residual soil deposits. It is unknown whether collapsible soils are present on the project site.

Corrosive Soils

Corrosive soils can damage underground utilities including pipelines and cables, or weaken roadway structures. Generally, fine grained soils like clays are more likely to be corrosive (Appendix G of this EIR). Fine grained and potentially corrosive soils are expected to be encountered at the project site.

Paleontological Resources

Paleontological resources (fossils) are the remains of prehistoric plant and animal life. Fossil remains, such as bones teeth, shell, and wood, are found in geologic deposits (rock formations) within which they were originally buried. Many paleontological fossil sites are recorded in Imperial County and have been discovered during construction activities. Paleontological resources are typically impacted when earthwork activities, such as mass excavation cut into geological deposits (formations) with buried fossils.

The project site is in the Salton Basin near the shoreline of ancient Lake Cahuilla. The lake covered much of the Imperial Valley and created an extensive lacustrine environment. Lake Cahuilla experienced several fill recession episodes before it finally dried up about 300 years ago. In 1905, the Colorado River overflowed into the Salton Basin creating the present-day Salton Sea. As previously mentioned above, the project site is generally underlain by deposits from periodic flooding of the Colorado River and Lake Cahuilla (Appendix G of this EIR). Sediments from this formation have yielded fossilized remains of continental vertebrates, invertebrates, and plants at numerous previously recorded fossil sites in the Imperial Valley. Therefore, the project site is considered paleontologically sensitive.

3.7.2 Regulatory Setting

This section identifies and summarizes laws, policies, and regulations that are applicable to the project.

Federal

Earthquake Hazards Reduction Act

The Earthquake Hazards Reduction Act was enacted in 1977 to “reduce the risks to life and property from future earthquakes in the United States through the establishment and maintenance of an effective earthquake hazards and reduction program.” To accomplish this, the Act established the National Earthquake Hazards Reduction Program (NEHRP). This program was significantly amended in November 1990 by NEHRP, which refined the description of agency responsibilities, program goals, and objectives.

NEHRP’s mission includes improved understanding, characterization, and prediction of hazards and vulnerabilities; improvement of building codes and land use practices; risk reduction through post-earthquake investigations and education; development and improvement of design and construction techniques; improvement of mitigation capacity; and accelerated application of research results. The NEHRP designates the Federal Emergency Management Agency as the lead agency of the program and assigns it several planning, coordinating, and reporting responsibilities. Programs under NEHRP help inform and guide planning and building code requirements such as emergency evacuation responsibilities and seismic code standards such as those to which the project would be required to adhere.

State

Alquist-Priolo Special Studies Earthquake Hazards Act

The APEHA was passed into law following the destructive February 9, 1971, San Fernando earthquake. The APEHA provides a mechanism for reducing losses from surface fault rupture on a statewide basis. The intent of the APEHA is to ensure public safety by prohibiting the siting of most

structures for human occupancy across traces of active faults that constitute a potential hazard to structures from surface faulting or fault creep. The state geologist (Chief of the California Division of Mines and Geology) is required to identify “earthquake fault zones” along known active faults in California. Counties and cities must withhold development permits for human occupancy projects within these zones unless geologic studies demonstrate that there would be no issues associated with the development of projects. The project site is not located within a currently mapped APEHA zone.

California Building Code

The California Building Standards Commission is responsible for coordinating, managing, adopting, and approving building codes in California. CCR Title 24 is reserved for state regulations that govern the design and construction of buildings, associated facilities, and equipment, known as building standards. The California Building Code (CBC) is based on the Federal Uniform Building Code used widely throughout the country (generally adopted on a state-by-state or district-by-district basis). The California Health and Safety Code (HSC) Section and 18980 HSC Section 18902 give CCR Title 24 the name of California Building Standards Code. The updates to the 2019 California Building Standards Code were published on January 1, 2021, with an effective date of July 1, 2021.

Local

County of Imperial Land Use Ordinance

Title 9 Division 15 (Geological Hazards) of the County Land Use Ordinance has established procedures and standards for development within earthquake fault zones. Per County regulations, construction of buildings intended for human occupancy are prohibited across the trace of an active fault. An exception exists when such buildings located near the fault or within a designated Special Studies Zone are demonstrated through a geotechnical analysis and report not to expose a person to undue hazard created by the construction.

County of Imperial General Plan

The County of Imperial General Plan, Seismic and Public Safety Element identifies potential natural and human-induced hazards and provides policy to avoid or minimize the risk associated with hazards. The Seismic and Public Safety Element identifies ‘lifelines and critical facilities’ whose disruption could endanger the public safety. Lifelines are defined as networks of services that extend over a wide area and are vital to the public welfare, and can be classified into four categories: energy, water, transportation, and communications. The IID has a formal Disaster Readiness Standard Operating Procedure for the Water Department, Power Department, and the entire District staff for response to earthquakes and other emergencies.

Table 3.7-2 analyzes the consistency of the project with specific policies contained in the County of Imperial General Plan associated with geology, soils, and seismicity. While this EIR analyzes the project’s consistency with the General Plan pursuant to CEQA Guidelines Section 15125(d), the Imperial County Board of Supervisors ultimately determines consistency with the General Plan.



Table 3.7-2. Project Consistency with Applicable General Plan Policies

General Plan Policies	Consistency with General Plan	Analysis
Seismic and Public Safety Element		
Goal 1. Include public health and safety considerations in land use planning.	Consistent	<p>Division 15 of the County Land Use Ordinance has established procedures and standards for development within earthquake fault zones. Per County regulations, construction of buildings intended for human occupancy which are located across the trace of an active fault are prohibited. An exception exists when such buildings located near the fault or within a designated Special Studies Zone are demonstrated through a geotechnical analysis and report not to expose a person to undue hazard created by the construction.</p> <p>Since the project site is located in a seismically active area, the project is required to be designed in accordance with the CBC for near source factors derived from a design basis earthquake based on a peak ground acceleration of 0.50 gravity. It should be noted that, the project would be remotely operated and would not require any habitable structures on site. In considering these factors in conjunction with mitigation requirements outlined in the impact analysis, the risks associated with seismic hazards would be minimized.</p> <p>A preliminary geotechnical report has been prepared for the proposed project. The preliminary geotechnical report has been referenced in this environmental document. Additionally, a design-level geotechnical investigation will be conducted to evaluate the potential for site specific hazards associated with seismic activity.</p>
Objective 1.1. Ensure that data on geological hazards is incorporated into the land use review process, and future development process.		
Objective 1.3. Regulate development adjacent to or near all mineral deposits and geothermal operations.		
Objective 1.4. Require, where possessing the authority, that avoidable seismic risks be avoided; and that measures, commensurate with risks, be taken to reduce injury, loss of life, destruction of property, and disruption of service.		
Objective 1.7. Require developers to provide information related to geologic and seismic hazards when siting a proposed project.		
Goal 2: Minimize potential hazards to public health, safety, and welfare and prevent the loss of life and damage to health and property resulting from both natural and human-related phenomena.		
Objective 2.2. Reduce risk and damage due to seismic hazards by appropriate regulation.		
Objective 2.5 Minimize injury, loss of life, and damage to property by implementing all state codes where applicable.		
Objective 2.8 Prevent and reduce death, injuries, property damage, and economic and social dislocation resulting from natural hazards including flooding, land subsidence, earthquakes, other geologic phenomena, levee or dam failure, urban and wildland fires and building collapse by appropriate planning and emergency measures.		

Source: County of Imperial 1997

3.7.3 Impacts and Mitigation Measures

This section presents the significance criteria used for considering project impacts related to geologic and soil conditions, the methodology employed for the evaluation, an impact evaluation, and mitigation requirements, if necessary.

Thresholds of Significance

Based on CEQA Guidelines Appendix G, project impacts related to geology and soils are considered significant if any of the following occur:

- Directly or indirectly cause potential substantive adverse effects, including the risk of loss, injury, or death involving:
 - Rupture of a known earthquake fault, as delineated on the most recent AP Earthquake Fault Zoning Map issued by the state geologist for the area or based on other substantial evidence of a known fault; (Refer to Division of Mines and Geology Special Publication 42)
 - Strong seismic ground shaking
 - Seismic related ground failure, including liquefaction
 - Landslides
- Result in substantial soil erosion or the loss of topsoil
- Be located on a geologic unit or soil that is unstable or that would become unstable as a result of the project, and potentially result in on- or off-site landslide, lateral spreading, subsidence, liquefaction or collapse
- Be located on expansive soil, as defined in Table 18-1-B of the Uniform Building Code (1994), creating substantial direct or indirect risks to life or property
- Have soils incapable of adequately supporting the use of septic tanks or alternative wastewater disposal systems where sewers are not available for the disposal of wastewater
- Directly or indirectly destroy a unique paleontological resource or site or unique geologic feature

Methodology

This analysis evaluates the potential for the project, as described in Chapter 2, Project Description, to interact with local geologic and soil conditions on the project site. A preliminary geological and geotechnical hazard evaluation report was prepared for the project. The information obtained from the report was reviewed and summarized to present the existing geologic and soil conditions on the project site. This analysis considers whether these conditions would result in an exceedance of one or more of the applied significance criteria as identified above.

Impact Analysis

Impact 3.7-1 *Would the project directly or indirectly cause potential substantive adverse effects, including the risk of loss, injury, or death involving:*

Rupture of a known earthquake fault, as delineated on the most recent AP Earthquake Fault Zoning Map issued by the state geologist for the area or based on

other substantial evidence of a known fault; (Refer to Division of Mines and Geology Special Publication 42)?

As previously discussed above, the project site is located in the seismically active Imperial Valley of southern California with several mapped faults of the San Andreas Fault System traversing the region. As shown in Table 3.7-1, the project site is not located on an active fault. Furthermore, no portion of the project site is within a designated APEHA zone, and, therefore, the potential for ground rupture to occur within the project site is considered unlikely. Based on these considerations, the project would not directly or indirectly cause potential substantive adverse effects, including the risk of loss, injury, or death involving rupture of a known earthquake fault. This is considered a less than significant impact.

Mitigation Measure(s)

No mitigation measures are required.

Impact 3.7-2 Would the project directly or indirectly cause potential substantive adverse effects, including the risk of loss, injury, or death involving:

Strong seismic ground shaking?

As previously discussed above, the closest mapped fault to the project site is the Imperial Fault (fault strand 5), located approximately 2.36 miles west. In the event of an earthquake along this fault or another regional fault, seismic hazards related to ground motion could occur in susceptible areas within the project site. The intensity of such an event would depend on the causative fault and the distance to the epicenter, the moment magnitude, and the duration of shaking.

Even with the integration of building standards, ground shaking within the project site could cause some structural damage to the facility structures or, at least, cause unsecured objects to fall. During a stronger seismic event, ground shaking could result in structural damage or collapse of electrical distribution facilities. Given the potentially hazardous nature of the project facilities, the potential impact of ground motion during an earthquake is considered a significant impact, as proposed structures, such as the substation and transmission lines could be damaged. However, implementation of Mitigation Measure GEO-1, which requires preparation of a design-level geotechnical report, would reduce the potential impacts associated with ground shaking to a level less than significant.

Mitigation Measure(s)

GEO-1 Prepare Geotechnical Report(s) as Part of Final Engineering for the Project and Implement Required Measures. Facility design for all project components shall comply with the site-specific design recommendations as provided by a licensed geotechnical or civil engineer to be retained by the project applicant. The final geotechnical and/or civil engineering report shall address and make recommendations on the following:

- Site preparation
- Soil bearing capacity
- Appropriate sources and types of fill
- Potential need for soil amendments

- Structural foundations
- Grading practices
- Soil corrosion of concrete and steel
- Erosion/winterization
- Seismic ground shaking
- Liquefaction
- Expansive/unstable soils

In addition to the recommendations for the conditions listed above, the geotechnical investigation shall include subsurface testing of soil and groundwater conditions and shall determine appropriate foundation designs that are consistent with the version of the CBC that is applicable at the time building and grading permits are applied for. All recommendations contained in the final geotechnical engineering report shall be implemented by the project applicant. The final geotechnical and/or civil engineering report shall be submitted to Imperial County Public Works Department, Engineering Division for review and approval prior to issuance of building permits.

Significance after Mitigation

With implementation of Mitigation Measure GEO-1, potential impacts associated with strong seismic ground shaking would be reduced to a level less than significant with the implementation of recommendations made by a licensed geotechnical engineer in compliance with the CBC prepared as part of a formal geotechnical investigation.

Impact 3.7-3 Would the project directly or indirectly cause potential substantive adverse effects, including the risk of loss, injury, or death involving:

Seismic related ground failure, including liquefaction?

As previously discussed above, the factors known to influence liquefaction potential include soil type, relative density, grain size distribution, confining pressure, depth to groundwater, and the intensity and duration of the seismic ground shaking. Liquefaction is most prevalent in loose- to medium-dense, silty, sandy, and gravelly soils below the groundwater table. The project site has not been mapped for liquefaction potential by CGS (Appendix G of this EIR). However, given that the project site is underlain by sand and clay, there is a potential for liquefaction to occur on the project site. Additional geotechnical investigation would be required in order to assess the risk of liquefaction on the project site. The potential impact on liquefaction is considered a significant impact. Implementation of Mitigation Measure GEO-1, which requires the preparation of a design-level geotechnical report, would reduce the potential impact associated with liquefaction to a level less than significant.

Mitigation Measure(s)

No additional mitigation measures beyond Mitigation Measure GEO-1 are required.

Impact 3.7-4 Would the project directly or indirectly cause potential substantive adverse effects, including the risk of loss, injury, or death involving:

Landslides?

As stated above, the project site has a relatively flat topographic gradient. Therefore, the project would not directly or indirectly cause potential substantive adverse effects, including the risk of loss, injury, or death involving landslides and no impact would occur.

Mitigation Measure(s)

No mitigation measures are required.

Impact 3.7-5 Would the project result in substantial soil erosion or the loss of topsoil?

During the site grading and construction phases, large areas of unvegetated soil would be exposed to erosive forces by water for extended periods of time due to ICAPCD dust suppression requirements. Unvegetated soils are much more likely to erode from precipitation than vegetated areas because plants act to disperse, infiltrate, and retain water. Construction activities involving soil disturbance, excavation, cutting/filling, stockpiling, and grading activities could result in increased erosion and sedimentation to surface waters. Construction could produce sediment-laden stormwater runoff (nonpoint source pollution), a major contributor to the degradation of water quality. If precautions are not taken to contain contaminants, construction-related erosion impacts are considered a significant impact.

As provided in Mitigation Measure GEO-1, during final engineering for the project, a design-level geotechnical study would identify appropriate measures for the project related to soil erosion. In addition, as part of Mitigation Measure HYD-1 provided in Section 3.10 Hydrology/Water Quality, potential impacts from erosion during construction activities would be reduced to a level less than significant with the preparation of a SWPPP for sediment and erosion control and implementation of BMPs to reduce erosion from the construction site.

The project is not expected to result in substantial soil erosion or the loss of topsoil over the long term. The project applicant would be required to implement on-site erosion control measures in accordance with County standards, which require the preparation, review, and approval of a grading plan by the County Engineer. Therefore, with implementation of Mitigation Measure GEO-1 and Mitigation Measure HYD-1 identified in Section 3.10 Hydrology/Water Quality, impacts from construction-related erosion would be reduced to a level less than significant.

Mitigation Measure(s)

No additional mitigation measures beyond Mitigation Measure GEO-1 and Mitigation Measure HYD-1 are required.

Significance after Mitigation

With implementation of Mitigation Measure GEO-1 and Mitigation Measure HYD-1 in Section 3.10 Hydrology/Water Quality, potential impacts from erosion during construction activities would be reduced to a level less than significant with the preparation of a SWPPP and implementation of BMPs to reduce erosion from the construction site.

Impact 3.7-6 Would the project be located on a geologic unit or soil that is unstable or that would become unstable as a result of the project, and potentially result in on- or off-site landslide, lateral spreading, subsidence, liquefaction or collapse?

The potential for lateral spreading to occur on the project site has not yet been determined. Additional geotechnical investigation would be required in order to assess the risk of lateral spreading to occur on the project site. The potential impact associated with lateral spreading is considered a significant impact.

The project site is not located in an area of known ground subsidence or within any delineated zones of subsidence due to groundwater pumping or oil extraction. The potential for subsidence to occur on the project site is considered low. Therefore, the proposed project would result in a less than significant impact associated with ground subsidence.

As described above, given that the project site is underlain by sand and clay, there is a potential for liquefaction to occur on the project site. Additional geotechnical investigation would be required in order to assess the risk of liquefaction on the project site. The potential impact on liquefaction is considered a significant impact.

It is unknown whether collapsible soils are present on the project site. Additional geotechnical investigation would be required in order to assess the risk of collapsible soils to occur on the project site. The potential impact associated with collapsible soils is considered a significant impact.

Implementation of Mitigation Measure GEO-1, which requires the preparation of a design-level geotechnical report, would reduce the potential impacts associated with lateral spreading, liquefaction, and collapsible soils to a level less than significant.

Mitigation Measure(s)

No additional mitigation measures beyond Mitigation Measure GEO-1 are required.

Impact 3.7-7 Would the project be located on expansive soil, as defined in Table 18-1-B of the Uniform Building Code (1994), creating substantial direct or indirect risks to life or property?

As stated above, expansive soils are characterized by their ability to undergo significant volume changes (shrink or swell) due to variations in moisture content. Changes in soil moisture content can result from precipitation, landscape irrigation, utility leakage, roof drainage, perched groundwater, drought, or other factors and may result in unacceptable settlement or heave of structures. The project site is underlain by sand, gravelly sand and clay/silty clay. Generally, sands are not considered expansive soils. However, clays may exhibit moderate to high expansion potential due to variation in moisture content. Unless properly mitigated, shrink-swell soils could exert additional pressure on buried structures and electrical connections producing shrinkage cracks that could allow water infiltration and compromise the integrity of backfill material. These conditions could be worsened if structural facilities are constructed directly on expansive soil materials. This potential impact would be significant as structures could be damaged by these types of soils. In addition, the on-site soils, particularly clay /silty clay, are known to be corrosive. Corrosive soils can damage underground utilities including pipelines and cables, or weaken roadway structures. A site-specific geotechnical investigation would be required at the project site to determine the extent and effect of problematic soils. Implementation of Mitigation Measure GEO-1, which requires the preparation of a design-level

geotechnical report, would reduce potential impacts associated with expansive and corrosive soils to a level less than significant.

Mitigation Measure(s)

No additional mitigation measures beyond Mitigation Measure GEO-1 are required.

Impact 3.7-8 Would the project have soils incapable of adequately supporting the use of septic tanks or alternative wastewater disposal systems where sewers are not available for the disposal of wastewater?

The proposed project would not require an operations and maintenance building. The proposed solar facility would be remotely operated, controlled and monitored and with no requirement for daily on-site employees. Therefore, no septic or other wastewater disposal systems would be required for the project and no impact would occur.

Mitigation Measure(s)

No mitigation measures are required.

Impact 3.7-9 Would the project directly or indirectly destroy a unique paleontological resource or site or unique geologic feature?

As stated above, the project site is in the Salton Basin near the shoreline of ancient Lake Cahuilla. The lake covered much of the Imperial Valley and created an extensive lacustrine environment. Lake Cahuilla experienced several fill recession episodes before it finally dried up about 300 years ago. In 1905, the Colorado River overflowed into the Salton Basin creating the present-day Salton Sea. As previously mentioned above, the project site is generally underlain by deposits from periodic flooding of the Colorado River and Lake Cahuilla (Appendix G of this EIR). Sediments from this formation have yielded fossilized remains of continental vertebrates, invertebrates, and plants at numerous previously recorded fossil sites in the Imperial Valley. Therefore, the project site is considered paleontologically sensitive.

Although unlikely, project construction has the potential to unearth and/or potentially destroy previously undiscovered paleontological resources. This potential impact is considered a significant impact. However, implementation of Mitigation Measure GEO-2 would reduce the potential impact on paleontological resources to a level less than significant.

Mitigation Measure(s)

GEO-2 Paleontological Resources. In the event that unanticipated paleontological resources or unique geologic resources are encountered during ground-disturbing activities, work must cease within 50 feet of the discovery and a paleontologist shall be hired to assess the scientific significance of the find. The consulting paleontologist shall have knowledge of local paleontology and the minimum levels of experience and expertise as defined by the *Society of Vertebrate Paleontology's Standard Procedures (2010) for the Assessment and Mitigation of Adverse Impacts to Paleontological Resources*. If any paleontological resources or unique geologic features are found within the project site, the consulting paleontologist shall prepare a paleontological Treatment and Monitoring Plan to include the methods that will be used to protect paleontological resources that may exist within the project site, as well as procedures

for monitoring, fossil preparation and identification, curation of specimens into an accredited repository, and preparation of a report at the conclusion of the monitoring program.

Significance after Mitigation

Implementation of Mitigation Measure GEO-2 would reduce the potential impact on paleontological resources to a level less than significant. In the event that unanticipated paleontological resources or unique geologic resources are encountered during ground-disturbing activities, work must cease within 50 feet of the discovery and a paleontologist shall be hired to assess the scientific significance of the find.

3.7.4 Decommissioning/Restoration and Residual Impacts

Decommissioning/Restoration

Decommissioning and restoration of the project site at the end of its use as a solar facility would involve the removal of structures and restoration to prior (pre-solar project) conditions. No geologic or soil impacts associated with the restoration activities would be anticipated, and, therefore, no impact is identified.

No impact is anticipated from restoration activities as the ground disturbance and associated impacts on paleontological resources will have occurred during the construction phase of the project.

Residual

With implementation of Mitigation Measure GEO-1, impacts related to strong seismic ground shaking, liquefaction, lateral spreading, collapsible soils, expansive soils, and corrosive soils would be reduced to a level less than significant. With implementation of Mitigation Measure GEO-1 and Mitigation Measure HYD-1 in Section 3.10 Hydrology/Water Quality, potential impacts from erosion during construction activities would be reduced to a level less than significant. Implementation of Mitigation Measure GEO-2 would reduce the potential impact on paleontological resources to a level less than significant. The project would not result in residual significant and unmitigable impacts related to geology and soil resources.

3.8 Greenhouse Gas Emissions

This section includes an overview of existing greenhouse gas (GHG) emissions within the project area and identifies applicable federal, state, and local policies related to global climate change. The impact assessment provides an evaluation of potential adverse effects with regards to GHG emissions based on criteria derived from the CEQA Guidelines in conjunction with actions proposed in Chapter 2, Project Description. ECORP Consulting, Inc. prepared an *Air Quality and Greenhouse Gas Assessment* that assesses the climate change impacts of the VEGA SES 4 Solar Energy Project. This report is included in Appendix C of this EIR.

3.8.1 Existing Conditions

Greenhouse Gases

Climate change refers to long-term changes in temperature, precipitation, wind patterns, and other elements of the earth's climate system. An ever-increasing body of scientific research attributes these climatological changes to GHGs, particularly those generated from the production and use of fossil fuels.

GHGs refer to atmospheric gases that absorb solar radiation and subsequently emit radiation in the thermal infrared region of the energy spectrum, trapping heat in the Earth's atmosphere. These gases include carbon dioxide (CO₂), methane (CH₄), nitrous oxide (N₂O), and water vapor, among others. While climate change has been a concern for several decades, the establishment of the Intergovernmental Panel on Climate Change (IPCC) by the United Nations and World Meteorological Organization in 1988 has led to increased efforts devoted to GHG emissions reduction and climate change research and policy.

The dominant GHG emitted is CO₂, mostly from fossil fuel combustion. GHGs differ in how much heat each can trap in the atmosphere (i.e., global warming potential [GWP]). When accounting for GHGs, all types of GHG emissions are expressed in terms of carbon dioxide equivalent (CO₂e) and are typically quantified in metric tons (MT) or million metric tons. The GWP of a GHG is based on several factors, including the relative effectiveness of a gas to absorb infrared radiation and length of time that the gas remains in the atmosphere ("atmospheric lifetime"). The GWP of each gas is measured relative to CO₂, the most abundant GHG. The definition of GWP for a particular GHG is expressed relative to CO₂ over a specified time period. CH₄ traps over 25 times more heat per molecule than CO₂, and N₂O absorbs 298 times more heat per molecule than CO₂ (Appendix C of this EIR). State law defines GHGs as any of the following compounds CO₂, CH₄, N₂O, hydrofluorocarbons (HFC), perfluorocarbons (PFC) and sulfur hexafluoride (SF₆) (California HSC Section 38505(g)).

CO₂ is a colorless, odorless gas consisting of molecules made up of two oxygen atoms and one carbon atom. CO₂ is produced when an organic carbon compound, such as wood, or fossilized organic matter, such as coal, oil, or natural gas, is burned in the presence of oxygen. CO₂ is removed from the atmosphere by CO₂ "sinks", such as absorption by seawater and photosynthesis by ocean dwelling plankton and land plants, including forests and grasslands; however, seawater is also a source of CO₂ to the atmosphere, along with land plants, animals, and soils, when CO₂ is released during respiration. Whereas the natural production and absorption of CO₂ is achieved through the terrestrial biosphere and the ocean, humankind has altered the natural carbon cycle by burning coal, oil, natural gas, and wood.

CH₄ is a colorless, odorless non-toxic gas consisting of molecules made up of four hydrogen atoms and one carbon atom. CH₄ is combustible, and it is the main constituent of natural gas—a fossil fuel. CH₄ is released when organic matter decomposes in low oxygen environments. Natural sources include wetlands, swamps and marshes, termites, and oceans. Human sources include the mining of fossil fuels and transportation of natural gas, digestive processes in ruminant animals, such as cattle, rice paddies and the buried waste in landfills. Over the last 50 years, human activities, such as growing rice, raising cattle, using natural gas, and mining coal have added to the atmospheric concentration of CH₄. Other anthropogenic sources include fossil-fuel combustion and biomass burning.

N₂O is a colorless, non-flammable gas with a sweetish odor, commonly known as "laughing gas", and sometimes used as an anesthetic. N₂O is naturally produced in the oceans and in rainforests. Man-made sources of N₂O include the use of fertilizers in agriculture, nylon and nitric acid production, cars with catalytic converters and the burning of organic matter. Concentrations of N₂O also began to rise at the beginning of the industrial revolution.

Chlorofluorocarbons (CFC) are gases formed synthetically by replacing all hydrogen atoms in CH₄ or ethane with chlorine and/or fluorine atoms. CFCs are nontoxic, nonflammable, insoluble, and chemically un-reactive in the troposphere (the level of air at the Earth's surface). CFCs have no natural source but were first synthesized in 1928. It was used for refrigerants, aerosol propellants, and cleaning solvents. Because of the discovery that they are able to destroy stratospheric ozone (O₃), an ongoing global effort to halt their production was undertaken and has been extremely successful, so much so that levels of the major CFCs are now remaining steady or declining; however, their long atmospheric lifetimes mean that some of the CFCs will remain in the atmosphere for over 100 years.

HFCs are synthesized chemicals that are used as a substitute for CFCs. Out of all of the GHGs; HFCs are one of three groups with the highest GWP. HFCs are synthesized for applications, such as automobile air conditioners and refrigerants.

PFCs have stable molecular structures and do not break down through the chemical processes in the lower atmosphere. High-energy ultraviolet rays about 60 kilometers above Earth's surface are able to destroy the compounds. Because of this, PFCs have very long lifetimes, between 10,000 and 50,000 years. The two main sources of PFCs are primary aluminum production and semiconductor manufacture.

SF₆ is an extremely potent GHG. SF₆ is very persistent, with an atmospheric lifetime of more than 1,000 years. Thus, a relatively small amount of SF₆ can have a significant long-term impact on global climate change. SF₆ is human-made, and the primary user of SF₆ is the electric power industry. Because of its inertness and dielectric properties, it is the industry's preferred gas for electrical insulation, current interruption, and arc quenching (to prevent fires) in the transmission and distribution of electricity. SF₆ is used extensively in high voltage circuit breakers and switchgear, and in the magnesium metal casting industry.

Statewide Greenhouse Gas Emissions Inventory

In 2020, CARB released the 2020 edition of the California GHG inventory covering calendar year 2018 emissions. In 2018, California emitted 425.3 million gross metric tons of CO_{2e} including from imported electricity. The current inventory covers the years 2000 to 2018 and is summarized in Table 3.8-1. Data sources used to calculate this GHG inventory include California and Federal agencies, international organizations, and industry associations. The calculation methodologies are consistent with guidance from the IPCC. The 2000 emissions level is the sum total of sources from all sectors and categories in the inventory. The inventory is divided into seven broad sectors and categories in

the inventory. These sectors include agriculture, commercial and residential, electric power, industrial, transportation, recycling and waste, and high GWP gases.

As shown in Table 3.8-1, combustion of fossil fuel in the transportation sector was the single largest source of California’s GHG emissions in 2018, accounting for approximately 30 percent of total GHG emissions in the state.

Table 3.8-1. California Greenhouse Gas Emissions Inventory 2000 to 2018

Sector	Total 2000 Emissions (MMTCO _{2e})	Total 2018 Emissions (MMTCO _{2e})
Agriculture	30.97	32.57
Commercial and Residential	43.95	41.37
Electric Power	104.75	63.11
Industrial	96.18	89.18
Transportation	178.40	169.50
Recycling and Waste	7.67	9.09
High GWP Gases	6.28	20.46

Source: CARB 2020

Notes:

GWP=global warming potential; MMTCO_{2e}=million metric tons of CO₂ equivalent

Potential Effects of Climate Change

Globally, climate change has the potential to affect numerous environmental resources through uncertain impacts related to future air temperatures and precipitation patterns. Although climate change is driven by global atmospheric conditions, climate change impacts are felt locally. A scientific consensus confirms that climate change is already affecting California.

The California Natural Resources Agency’s Fourth Climate Change Assessment (Fourth Assessment) produced updated climate projections that provide state-of-the-art understanding of different possible climate futures for California. The science is highly certain that California (and the world) will continue to warm and experience greater impacts from climate change in the future. While the IPCC and the National Climate Assessment have released descriptions of scientific consensus on climate change for the world and the U.S., respectively, the Fourth Assessment summarizes the current understanding of climate impacts and adaptation options in California (California Natural Resources Agency 2018). Projected changes in California include:

- **Temperatures:** If GHG emissions continue at current rates then California will experience average daily high temperatures that are warmer than the historical average by:
 - 2.7 Fahrenheit (°F) from 2006 to 2039
 - 5.8°F from 2040 to 2069
 - 8.8°F from 2070 to 2100

- **Wildfire:** One Fourth Assessment model suggests large wildfires (greater than 25,000 acres) could become 50 percent more frequent by the end of century if emissions are not reduced. The model produces more years with extremely high areas burned, even compared to the historically destructive wildfires of 2017 and 2018. By the end of the century, California could experience wildfires that burn up to a maximum of 178 percent more acres per year than current averages.
- **Sea-Level Rise:** If emissions continue at current rates, the Fourth Assessment model results indicate that total sea-level rise by 2100 is expected to be 54 inches, almost twice the rise that would occur if GHG emissions are lowered to reduce risk.
- **Snowpack:** By 2050, the average water supply from snowpack is projected to decline to 2/3 from historical levels. If emissions reductions do not occur, water from snowpack could fall to less than 1/3 of historical levels by 2100.
- **Agriculture:** Agricultural production could face climate-related water shortages of up to 16 percent in certain regions. Regardless of whether California receives more or less annual precipitation in the future, the state will be dryer because hotter conditions will increase the loss of soil moisture (California Natural Resources Agency 2018).

3.8.2 Regulatory Setting

This section identifies and summarizes federal, state, and local laws, policies, and regulations that are applicable to the project.

Federal

At the federal level, there is currently no overarching law related to climate change or the reduction of GHGs. The U.S. EPA is developing regulations under the CAA to be adopted in the near future, pursuant to the U.S. EPA's authority under the CAA. Foremost amongst recent developments have been the settlement agreements between the U.S. EPA, several states, and nongovernmental organizations (NGO) to address GHG emissions from electric generating units and refineries; the U.S. Supreme Court's decision in *Massachusetts v. EPA*; and U.S. EPA's "Endangerment Finding," "Cause or Contribute Finding," and "Mandatory Reporting Rule." On September 20, 2013, the U.S. EPA issued a proposal to limit carbon pollution from new power plants. The U.S. EPA is proposing to set separate standards for natural gas-fired turbines and coal-fired units.

Although periodically debated in Congress, no federal legislation concerning GHG limitations has yet been adopted. In *Coalition for Responsible Regulation, Inc., et al. v. EPA*, the United States Court of Appeals upheld the U.S. EPA's authority to regulate GHG emissions under CAA. Furthermore, under the authority of the CAA, the EPA is beginning to regulate GHG emissions starting with large stationary sources. In 2010, the U.S. EPA set GHG thresholds to define when permits under the New Source Review Prevention of Significant Deterioration (PSD) standard and Title V Operating Permit programs are required for new and existing industrial facilities. In 2012, U.S. EPA proposed a carbon pollution standard for new power plants.

Corporate Average Fuel Standards

Established by the U.S. Congress in 1975, the Corporate Average Fuel Economy (CAFE) standards reduce energy consumption by increasing the fuel economy of cars and light trucks. The National Highway Traffic Safety Administration (NHTSA) and U.S. EPA jointly administer the CAFE standards.

The U.S. Congress has specified that CAFE standards must be set at the “maximum feasible level” with consideration given for: (1) technological feasibility; (2) economic practicality; (3) effect of other standards on fuel economy; and (4) need for the nation to conserve energy.

Fuel efficiency standards for medium- and heavy-duty trucks have been jointly developed by U.S. EPA and NHTSA. The Phase 1 heavy-duty truck standards apply to combination tractors, heavy-duty pickup trucks and vans, and vocational vehicles for model years 2014 through 2018, and result in a reduction in fuel consumption from 6 to 23 percent over the 2010 baseline, depending on the vehicle type (U.S. EPA 2011). In 2012, the U.S. EPA and NHTSA also adopted the Phase 2 heavy-duty truck standards, which cover model years 2021 through 2027 and require the phase-in of a 5 to 25 percent reduction in fuel consumption over the 2017 baseline depending on the compliance year and vehicle type (U.S. EPA 2016).

State

Executive Order S-3-05 – Statewide Greenhouse Gas Emissions Targets

On June 1, 2005, the Governor issued EO S-3-05 which set the following GHG mission reduction targets:

- By 2020, reduce GHG emissions to 1990 levels
- By 2050, reduce GHG emissions to 80 percent below 1990 levels

This EO directed the secretary of the California EPA to oversee the efforts made to reach these targets, and to prepare biannual biennial reports on the progress made toward meeting the targets and on the impacts on California related to global warming. The first such Climate Action Team Assessment Report was produced in March 2006 and has been updated every two years thereafter. This goal was further reinforced with the passage of AB 32 in 2006 and SB 32 in 2016.

Executive Order S-01-07

This order, signed by Governor Schwarzenegger, sets forth the low carbon fuel standard (LCFS) for California. Under this EO, the carbon intensity of California’s transportation fuels is to be reduced by at least 10 percent by the year 2020. CARB re-adopted the LCFS regulation in September 2015, and the changes went into effect on January 1, 2016. The program establishes a strong framework to promote the low-carbon fuel adoption necessary to achieve the Governor’s 2030 and 2050 GHG reduction goals.

Assembly Bill 32 – California Global Warming Solutions Act

In 2006, the California legislature passed Assembly Bill (AB) 32 (Health and Safety Code § 38500 et seq., or AB 32), also known as the Global Warming Solutions Act. AB 32 requires CARB to design and implement feasible and cost-effective emission limits, regulations, and other measures, such that statewide GHG emissions are reduced to 1990 levels by 2020 (representing a 25 percent reduction in emissions). Pursuant to AB 32, CARB adopted a Scoping Plan in December 2008, which outlines measures to meet the 2020 GHG reduction goals. California is on track to meet or exceed the target of reducing GHG emissions to 1990 levels by the end of 2020.

The Scoping Plan is required by AB 32 to be updated at least every five years. The latest update, the 2017 Scoping Plan Update, addresses the 2030 target established by Senate Bill (SB) 32 as discussed below and establishes a proposed framework of action for California to meet a 40 percent reduction

in GHG emissions by 2030 compared to 1990 levels. The key programs that the Scoping Plan Update builds on include increasing the use of renewable energy in the state, the Cap-and-Trade Regulation, the Low Carbon Fuel Standard, and reduction of methane emissions from agricultural and other wastes.

Senate Bill 32 and Assembly Bill 197 of 2016

In August 2016, Governor Brown signed SB 32 and AB 197, which serve to extend California's GHG reduction programs beyond 2020. SB 32 amended the Health and Safety Code to include § 38566, which contains language to authorize CARB to achieve a statewide GHG emission reduction of at least 40 percent below 1990 levels by no later than December 31, 2030. SB 32 codified the targets established by Executive Order (EO) B-30-15 for 2030, which set the next interim step in the State's continuing efforts to pursue the long-term target expressed in EOs S-3-05 and B-30-15 of 80 percent below 1990 emissions levels by 2050.

Renewable Portfolio Standard

The RPS promotes diversification of the state's electricity supply and decreased reliance on fossil fuel energy sources. Originally adopted in 2002 with a goal to achieve a 20 percent renewable energy mix by 2020 (referred to as the "initial RPS"), the goals have been accelerated and increased by EOs S-14-08, S-21-09, SB 350, and SB 100.

The RPS is included in CARB's Scoping Plan list of GHG reduction measures to reduce energy sector emissions. It is designed to accelerate the transformation of the electricity sector through such means as investment in the energy transmission infrastructure and systems to allow integration of large quantities of intermittent wind and solar generation. Increased use of renewables would decrease California's reliance on fossil fuels, thus reducing emissions of GHGs from the electricity sector.

Senate Bill 350

The RPS program was further accelerated in 2015 with SB 350 which mandated a 50 percent RPS by 2030. SB 350 includes interim annual RPS targets with three-year compliance periods and requires 65 percent of RPS procurement to be derived from long-term contracts of 10 or more years.

Senate Bill 100

On September 10, 2018, Governor Brown signed SB 100, establishing that 100 percent of all electricity in California must be obtained from renewable and zero-carbon energy resources by December 31, 2045. SB 100 also creates new standards for the RPS goals established by SB 350 in 2015. Specifically, the bill increases required energy from renewable sources for both investor-owned utilities and publicly-owned utilities from 50 percent to 60 percent by 2030. Incrementally, these energy providers must also have a renewable energy supply of 33 percent by 2020, 44 percent by 2024, and 52 percent by 2027. California must procure 100 percent of its energy from carbon free energy sources by the end of 2045.

Climate Change Scoping Plan

The Scoping Plan released by CARB in 2008 outlined the state's strategy to achieve the AB 32 goals. This Scoping Plan, developed by CARB in coordination with the Climate Action Team, proposed a comprehensive set of actions designed to reduce overall GHG emissions in California, improve the environment, reduce dependence on oil, diversify our energy sources, save energy, create new jobs,

and enhance public health. It was adopted by CARB at its meeting in December 2008. According to the Scoping Plan, the 2020 target of 427 million MTCO_{2e} requires the reduction of 169 million MTCO_{2e}, or approximately 28.3 percent, from the state's projected 2020 BAU emissions level of 596 million MTCO_{2e}.

However, in August 2011, the Scoping Plan was re-approved by the Board and includes the Final Supplement to the Scoping Plan Functional Equivalent Document. This document includes expanded analysis of project alternatives as well as updates the 2020 emission projections in light of the current economic forecasts. Considering the updated 2020 BAU estimate of 507 million MTCO_{2e}, only a 16 percent reduction below the estimated new BAU levels would be necessary to return to 1990 levels by 2020. The 2011 Scoping Plan expands the list of nine Early Action Measures into a list of 39 Recommended Actions.

In May 2014, CARB developed; in collaboration with the Climate Action Team, the *First Update to California's Climate Change Scoping Plan (Update)*, which shows that California is on track to meet the near-term 2020 GHG limit and is well positioned to maintain and continue reductions beyond 2020 as required by AB 32. In accordance with the United Nations Framework Convention on Climate Change (UNFCCC), CARB is beginning to transition to the use of the AR4's 100-year GWPs in its climate change programs. CARB has recalculated the 1990 GHG emissions level with the AR4 GWPs to be 431 million MTCO_{2e}; therefore, the 2020 GHG emissions limit established in response to AB 32 is now slightly higher than the 427 million MTCO_{2e} in the initial Scoping Plan.

CARB adopted the latest update to the Climate Change Scoping Plan in December 2017. The 2017 Scoping Plan is guided by the EO B-30-15 GHG reduction target of 40 percent below 1990 levels by 2030. The 2017 Scoping Plan builds upon the framework established by the initial Scoping Plan and the First Update, while identifying new, technologically feasible, and cost-effective strategies to ensure that California meets its GHG reduction targets in a way that promotes and rewards innovation, continues to foster economic growth, and delivers improvements to the environment and public health, including in disadvantaged communities. The Plan includes policies to require direct GHG reductions at some of the State's largest stationary sources and mobile sources. These policies include the use of lower GHG fuels, efficiency regulations, and the Cap-and-Trade Program, which constrains and reduces emissions at covered sources (CARB 2017).

The majority of the Scoping Plan's GHG reduction strategies are directed at the two sectors with the largest GHG emissions contributions: transportation and electricity generation. The GHG reduction strategies for these sectors involve statutory mandates affecting vehicle or fuel manufacture, public transit, and public utilities. The reduction strategies employed by CARB are designed to reduce emissions from existing sources as well as future sources.

Senate Bill 97

SB 97, enacted in 2007, amends the CEQA statute to clearly establish that GHG emissions and the effects of GHG emissions are appropriate subjects for CEQA analysis. It directs Office of Planning and Research (OPR) to develop draft CEQA Guidelines "for the mitigation of GHG emissions or the effects of GHG emissions" by July 1, 2009, and directs the Resources Agency to certify and adopt the CEQA Guidelines by January 1, 2010.

On December 30, 2009, the Natural Resources Agency adopted amendments to the CEQA Guidelines in the CCR. The amendments went into effect on March 18, 2010, and are summarized below:

- Climate action plans and other GHG reduction plans can be used to determine whether a project has significant impacts, based upon its compliance with the plan.

- Local governments are encouraged to quantify the GHG emissions of proposed projects, noting that they have the freedom to select the models and methodologies that best meet their needs and circumstances. In addition, consideration of several qualitative factors may be used in the determination of significance, such as the extent to which the given project complies with state, regional, or local GHG reduction plans and policies. The Guidelines do not set or dictate specific thresholds of significance.
- When creating their own thresholds of significance, local governments may consider the thresholds of significance adopted or recommended by other public agencies, or recommended by experts.
- New amendments include guidelines for determining methods to mitigate the effects of GHG emissions in Appendix G of the CEQA Guidelines.
- The Guidelines are clear to state that “to qualify as mitigation, specific measures from an existing plan must be identified and incorporated into the project; general compliance with a plan, by itself, is not mitigation.”
- The Guidelines promote the advantages of analyzing GHG impacts on an institutional, programmatic level, and, therefore, approve tiering of environmental analyses and highlights some benefits of such an approach.
- EIRs must specifically consider a project's energy use and energy efficiency potential, pursuant to Appendix F of the CEQA Guidelines.

Senate Bill 375 – Regional Emissions Targets

SB 375 requires that regions within the state which have a metropolitan planning organization (MPO) must adopt a sustainable communities' strategy as part of their RTPs. The strategy must be designed to achieve certain goals for the reduction of GHG emissions. The bill finds that “it will be necessary to achieve significant additional GHG reductions from changed land use patterns and improved transportation. Without improved land use and transportation policy, California will not be able to achieve the goals of AB 32.” SB 375 provides that new CEQA provisions be enacted to encourage developers to submit applications and local governments to make land use decisions that will help the state achieve its goals under AB 32,” and that “current planning models and analytical techniques used for making transportation infrastructure decisions and for air quality planning should be able to assess the effects of policy choices, such as residential development patterns, expanded transit service and accessibility, the walkability of communities, and the use of economic incentives and disincentives.”

Regional

Southern California Association of Governments - 2020-2045 Regional Transportation Plan/Sustainable Communities Strategy

The SCAG is the designated MPO for Los Angeles, Ventura, Orange, San Bernardino, Riverside, and Imperial Counties. CEQA requires that regional agencies like SCAG review projects and plans throughout its jurisdiction. SCAG, as the region’s “Clearinghouse,” collects information on projects of varying size and scope to provide a central point to monitor regional activity. SCAG has the responsibility of reviewing dozens of projects, plans, and programs every month. Projects and plans that are regionally significant must demonstrate to SCAG their consistency with a range of adopted regional plans and policies.

In September 2020, SCAG adopted the 2020-2045 RTP/SCS. The RTP/SCS includes a strong commitment to reduce emissions from transportation sources to comply with SB 375, improve public health, and meet the NAAQS as set forth by the federal CAA (see Section 3.4, Air Quality, of this EIR). The following SCAG goal is applicable to the project:

- Reduce greenhouse gas emissions and improve air quality

As a solar generation facility, the proposed project would improve air quality by reducing the use of fossil fuels in energy production.

Local

County of Imperial

Pursuant to the requirements of SB 97, the Resources Agency adopted amendments to the CEQA Guidelines to provide regulatory guidance on the analysis and mitigation of GHG emissions in CEQA documents, while giving lead agencies the discretion to set quantitative or qualitative thresholds for the assessment and mitigation of GHG and climate change impacts. Formal CEQA thresholds for lead agencies must always be established through a public hearing process. Imperial County has not established formal quantitative or qualitative thresholds through a public rulemaking process, but CEQA permits the lead agency to establish a project-specific threshold of significance if backed by substantial evidence, until such time as a formal threshold is approved.

3.8.3 Impacts and Mitigation Measures

Thresholds of Significance

Based on CEQA Guidelines Appendix G, project impacts related to GHG emissions are considered significant if any of the following occur:

- Generate GHG emissions, either directly or indirectly, that may have a significant impact on the environment
- Conflict with an applicable plan, policy, or regulation adopted for the purpose of reducing the emissions of GHGs

As discussed in Section 15064.4 of the CEQA Guidelines, the determination of the significance of GHG emissions calls for a careful judgment by the lead agency consistent with the provisions in Section 15064. A lead agency should make a good-faith effort, based to the extent possible on scientific and factual data, to describe, calculate or estimate the amount of GHG emissions resulting from a project. A lead agency shall have discretion to determine, in the context of a particular project, whether to:

1. Quantify greenhouse gas emissions resulting from a project; and/or
2. Rely on a qualitative analysis or performance-based standards.

A lead agency should consider the following factors, among others, when assessing the significance of impacts from GHG emissions on the environment:

1. The extent to which the project may increase or reduce GHG emissions as compared to the existing environmental setting;

2. Whether the project emissions exceed a threshold of significance that the lead agency determines applies to the project; and
3. The extent to which the project complies with regulations or requirements adopted to implement a statewide, regional, or local plan for the reduction or mitigation of GHG emissions. Such requirements must be adopted by the relevant public agency through a public review process and must reduce or mitigate the project's incremental contribution of GHG emissions. If there is substantial evidence that the possible effects of a particular project are still cumulatively considerable notwithstanding compliance with the adopted regulations or requirements, an EIR must be prepared for the project. In determining the significance of impacts, the lead agency may consider a project's consistency with the State's long-term climate goals or strategies, provided that substantial evidence supports the agency's analysis of how those goals or strategies address the project's incremental contribution to climate change and its conclusion that the project's incremental contribution is not cumulatively considerable.

Mojave Desert Air Quality Management District's Interim Thresholds

The ICAPCD has not adopted a GHG significance threshold. As previously described, Section 15064.7(c) of the CEQA Guidelines specifies that “[w]hen adopting or using thresholds of significance, a lead agency may consider thresholds of significance previously adopted or recommended by other public agencies, or recommended by experts, provided the decision of the lead agency to adopt such thresholds is supported by substantial evidence” (14 CCR 15064.7(c)). Thus, in the absence of any GHG emissions significance thresholds, the projected emissions are compared to the Mojave Desert Air Quality Management District (MDAQMD) numeric threshold of 100,000 metric tons of CO₂e annually.

While significance thresholds used in the Mojave Desert Air Basin are not binding on the ICAPCD or County of Imperial, they are instructive as a comparative metric of the project's potential GHG impact. This threshold is also appropriate as the MDAQMD GHG thresholds were formulated based on similar geography and climate patterns as found in Imperial County. Therefore, the 100,000-metric ton of CO₂e threshold is appropriate for this analysis.

Methodology

The project-related direct and indirect emissions of GHGs were estimated using the similar methods for quantification of criteria air pollutants, as described in Section 3.4 Air Quality. Where GHG emission quantification was required, emissions were modeled using CalEEMod, version 2020.4.0. CalEEMod is a statewide land use emissions computer model designed to quantify potential GHG emissions associated with both construction and operations from a variety of land use projects. Project construction-generated GHG emissions were calculated using CalEEMod model defaults for Imperial County coupled with information provided by the project applicant. For instance, construction activities would primarily involve demolition and grubbing, grading of the project site to establish access roads and pads for electrical equipment, trenching for underground electrical collection lines, and the installation of solar equipment and security fencing. Construction is estimated to take 12-18 months and would begin in late 2022 or 2023. The number of on-site construction workers for the solar facility is not expected to exceed 150 workers at any time. The number of on-site construction workers for the BESS and substation is not expected to exceed 100 workers at any one time. According to the Traffic Impact Study prepared for the project (Appendix K of this EIR), project construction would generate a maximum of 500 construction worker-commute trips in a single day.

Operational GHG emissions account for the maximum three workers visiting the site in a single day. Such visits include inspections, equipment servicing, site and landscape clearing, and periodic washing of the PV modules if needed (up to two times per year) to maintain power generation efficiency. Therefore, operational onsite equipment use is accounted in addition to the consumption of 10 acre-feet (3,259,000 gallons) of water annually.

Impact Analysis

Impact 3.8-1 Would the project generate GHG emissions, either directly or indirectly, that may have a significant impact on the environment?

Construction and operation of the project would result in a relatively small amount of GHG emissions. The project would generate GHG emissions during construction and routine operational activities at the project site.

Construction. Construction-related activities that would generate GHG emissions include worker commute trips, haul trucks carrying supplies and materials to and from the project site, and off-road construction equipment (e.g., dozers, loaders, excavators). Table 3.8-2 shows the specific construction generated GHG emissions that would result from construction of the project. Once construction is complete, the generation of these GHG emissions would cease.

Table 3.8-2. Project Construction-Related Greenhouse Gas Emissions

Emissions Source	CO ₂ e (metric tons/year)
Construction Year One	913
Construction Year Two	611
MDAQMD Significance Threshold	100,000
Exceed MDAQMD's Significance Threshold?	No

Source: Appendix C of this EIR

As shown in Table 3.8-2, the project would result in the generation of approximately 913 metric tons of CO₂e in the first calendar year of construction and 611 metric tons in the second calendar year of construction. Therefore, the construction emissions are less than the MDAQMD's screening threshold of 100,000 MTCO₂e per year. As previously described, this significance threshold is not binding on the project, yet in the absence of an established threshold from the ICAPCD or County it is instructive for comparison purposes. This threshold is also appropriate for use in this analysis as the MDAQMD GHG thresholds were formulated based on similar geography and climate patterns as found in Imperial County.

Operation. Once the project is constructed and operational, the proposed project would have no major stationary emission sources and would require minimal vehicular trips. Therefore, operation of the proposed solar facility would result in substantially lower emissions than project construction. Long-term GHG emissions attributed to operations of the project are identified in Table 3.8-3. As shown in Table 3.8-3, operational-generated emissions would generate approximately 1,194 metric tons of CO₂e annually. Therefore, the proposed project's operational emissions are less than the MDAQMD's screening threshold of 100,000 MTCO₂e per year. As shown in Table 3.8-3, the majority of emissions are attributable to indirect energy consumption. The BESS component of the project was modeled to account for HVAC use. However, this is potentially a conservative estimate since the energy source

for the BESS HVAC could include the solar energy generated by the project itself, which would be an emissions-free source of energy. Impacts would be less than significant.

Table 3.8-3. Project Operation-Related Greenhouse Gas Emissions

Emissions Source	CO ₂ e (metric tons/year)
Area Source	0
Energy	1,088
Mobile	7
Off-Road Equipment	8
Waste	82
Water	8
Total	1,194
MDAQMD Significance Threshold	100,000
Exceed MDAQMD's Significance Threshold?	No

Source: Appendix C of this EIR

Additionally, the project proposes a solar energy generation facility intended to generate renewable energy. Solar plants generate far less GHG life-cycle emissions (approximately 83 to 94 percent less) than fossil-fueled energy plants. The proposed project would contribute to the continued reduction of GHG emissions in the interconnected California and western U.S. electricity systems, as the energy produced by the project would displace GHG emissions that would otherwise be produced by existing business-as-usual power generation resources (including natural gas, coal, arid renewable combustion resources). The project would generate a maximum of four MW of electricity at any one time. Table 3.8-4 shows the emissions that would potentially be displaced by the proposed project. As shown in Table 3.8-4, the proposed project would potentially displace approximately 53,210 MTCO₂e per year, and approximately 1,596,596 MTCO₂e over the course of 30 years. The proposed project's annual indirect GHG emissions from the displacement of fossil fuel fired electricity generation is significantly higher than the project's annualized direct and indirect emissions sources. Implementation of the proposed project would result in a less than significant impact associated with the generation of GHG emissions.



Table 3.8-4. Proposed Project Displaced GHG Emissions (Metric Tons)

	Emissions (Metric Tons)			
	CO ₂	CH ₄	N ₂ O	CO ₂ e
Emissions Displaced Annually (metric tons)				
Displaced Natural-Gas Source Emissions	47,585	0.00	0.00	47,585
Displaced Coal-Source Emissions	5,626	0.037	0.028	5,635
Total	53,210	0.037	0.028	53,220
Emissions Displaced over 30 Years (metric tons)				
Total	1,596,309	1.118	0.838	1,596,596

Source: Appendix C of this EIR

Notes: In order to provide a conservative analysis, the proposed project is assumed to generate electricity 25 percent of the time available (2,190 hours annually). Heat Rate indicates the energy generator efficiency of existing fossil-fuel based energy generators. The heat rate of a power plant measures the amount of fuel used to generate one unit of electricity. Power plants with lower heat rates are more efficient than plants with higher heat rates. The CEC's "Updated Thermal Power Plant Efficiency Measures and Operational Characteristics for Production Cost Modeling" (2019) estimates heat rates and operating ranges for thermal power plants supplying energy to California. The average heat rate of power plants types are as follows: **Steam Boiler fueled by coal: 10,800 heat rate **Steam Boiler fueled by natural gas: 10,200 heat rate **Gas Turbine: 10,100 heat rate **Combined natural gas Boiler and Turbine: 7,640 heat rate. By omitting steam boilers fueled by coal since so little of California's energy is derived from coal, the average heat rate = 9,313 [(10,100 + 10,200 + 7,640) ÷ 3 = 9,313]. 100 MW (219,000,000 annual kWh) × 9,313 heat rate = 2,039,547,000,000 Btu displaced from fossil fuel production. Fossil fuel-based energy consumption in California is predominately derived from natural gas (37.06 percent). Coal constitutes 2.74 percent of all fossil fuel-based energy. Therefore, 865,175,837,400 of the displaced Btu is displaced natural gas and unspecified nonrenewable sources consumption and 55,883,587,800 of the displaced Btu is displaced coal. The heat content of coal is assumed at 24 million Btu per ton of coal burned. At a rate of 24 million Btu per ton of coal burned, the project would displace 2,328 tons of burned coal annually.

Mitigation Measure(s)

No mitigation measures are required.

Impact 3.8-2 Would the project conflict with an applicable plan, policy, or regulation adopted for the purpose of reducing the emissions of GHGs?

As discussed in Impact 3.8-1, the proposed project would generate a relatively small amount of GHG emissions. The proposed project-generated GHG emissions would not exceed the MDAQMD significance thresholds, which were prepared with the purpose of complying with statewide GHG-reduction efforts. While the project would emit some GHG emissions during construction and a very small amount during operations, the contribution of renewable resource energy production to meet the goals of the Renewable Portfolio Standard (Scoping Plan Measure E-3) would result in a net cumulative reduction of GHG emissions, a key environmental benefit. Scoping Plan Measure E-3, Renewable Portfolio Standard, of the Climate Change Scoping Plan requires that all investor-owned utility companies generate 60 percent of their energy demand from renewable sources by the year 2030. Therefore, the short-term minor generation of GHG emissions during construction, which is necessary to create this new, low-GHG emitting power-generating facility, as well as the negligible amount generated during ongoing maintenance operations, would be more than offset by GHG emission reductions associated with solar-generated energy during operation.

Increasing sources of solar energy is one of the measures identified under the Scoping Plan to reduce statewide GHG emissions. The proposed project would reduce GHG emissions in a manner consistent with SB 32 and other California GHG-reducing legislation by creating a new source of solar power to replace the current use of fossil-fuel power and reduce GHG emissions power generation and use.

Implementation of the proposed project would result in a less than significant impact associated with the potential to conflict with an applicable plan, policy, or regulation adopted for the purpose of reducing the emission of GHG.

Mitigation Measure(s)

No mitigation measures are required.

3.8.4 Decommissioning/Restoration and Residual Impacts

Decommissioning/Restoration

Similar to construction activities, decommissioning and restoration would result in GHG emissions below allowable thresholds. Construction activities during decommissioning and restoration would adhere to Mitigation Measures AQ-1 and AQ-2 outlined in Section 3.4, Air Quality of this EIR, further reducing GHG emissions. Therefore, the impact is considered less than significant.

Residual

The proposed project's GHG emissions would result in a less than significant impact. Project operation, subject to the provision of a CUP, would generally be consistent with statewide GHG emission goals and policies including SB 32. Project consistency with applicable plans, policies, and regulations adopted to reduce GHG emissions would ensure that the project would not result in any residual significant and unavoidable impacts with regards to global climate change.

3.9 Hazards and Hazardous Materials

Information contained in this section is summarized from the Phase I Environmental Site Assessment (ESA) prepared for the project by GS Lyon Consultants, Inc. The Phase I ESA prepared for the project site was used to assess the potential hazards and hazardous materials found on-site or adjacent to the project site. This report is included in Appendix H of this EIR. This section addresses potential hazards and hazardous materials for construction and operational impacts.

3.9.1 Existing Conditions

The project site is located on approximately 450 acres of privately-owned agriculturally-zoned land within unincorporated Imperial County that is not currently under cultivation. The boundaries of the project site include the All-American Canal forming the northern boundary, the U.S./Mexico international border forming the southern boundary, and undeveloped desert land forming the eastern boundary. The project site is currently characterized by flat and undeveloped land, portions of which have been disturbed associated with previous agricultural-related activities.

A farmyard is located in the north-central portion of the project site. A small masonry building housing water pumps, an above ground fuel storage tank (AST) and a storage building, all located within a chain-link fenced area comprise the farmyard. A small equipment storage area with a disc, a trap wagon, and other miscellaneous farm equipment is also located northeast of the farmyard area. Two central-pivot sprinklers are located in the central portion of the project site.

Records Review

A review of historic aerial photographs, historic topographic maps, historic Sanborn Fire Insurance maps, governmental regulatory databases, and other regulatory and agency databases was performed to evaluate potential adverse environmental conditions resulting from previous ownership and uses of the project site.

GS Lyon Consultants, Inc. contracted Environmental Data Resources, Inc. of Shelton, Connecticut which queries and maintains comprehensive environmental databases and historical information, including proprietary databases, aerial photography, topographic maps, Sanborn Maps, and city directories to generate a compilation of federal, state and tribal regulatory lists containing information regarding hazardous materials occurrences on or within the prescribed radii of American Society of Testing and Materials Practice E 1527-13. The search of each database was conducted using the approximate minimum search distances from the subject property defined by the Standard. The purpose of the records review is to obtain and review reasonably ascertainable records that would help identify recognized environmental conditions or historical recognized environmental conditions in connection with the project site. The project site is not identified in the Environmental Data Resources, Inc. report as being located on a hazardous materials site pursuant to Government Code Section 65962.5. The results of the background review are presented in the Phase I ESA (Appendix H of this EIR).

Historical aerial photographs from EDR dating back to 1937 and Google Earth aerial photographs from 1996 were reviewed. In 1937, the western portion of the subject site appears to have been fallow agricultural field while the eastern portion was vacant desert land and newly constructed All-American Canal is to the north of the project site. In 1953, the canals that crossed the All-American Canal had been removed leaving a heavily brushed area in the western portion of the project site.

The 1985 aerial photograph shows a circular agricultural area occupying the eastern portion of the project site. The 1996 to 2010 aerial photographs are similar to the 1985 aerial photograph; however, several small structures are noted in the area of the farmyard in the northcentral portion of the project site. The 2018 aerial photograph shows the subject site as being similar to the present time with the agricultural fields have been fallowed.

Site Reconnaissance

A site reconnaissance was performed on September 22, 2020. The site visit consisted of a driving the perimeter of the project site and randomly crossing the project site. The reconnaissance included visual observations of surficial conditions at the project site and observation of adjoining properties to the extent that they were visible from public areas. The site visit evaluated the project site and adjoining properties for potential hazardous materials/waste and petroleum product use, storage, disposal, or accidental release, including the following: presence of tank and drum storage; mechanical or electrical equipment likely to contain liquids; evidence of soil or pavement staining or stressed vegetation; ponds, pits, lagoons, or sumps; suspicious odors; fill and depressions; or any other condition indicative of potential contamination.

Underground and Aboveground Storage Tanks, Drums, or Containers

No underground storage tanks (USTs) were observed within the project site during the site reconnaissance. One AST was observed within the fenced farmyard; however access to the tank was not available at the time to determine fuel containment. Several steel 55-gallon drums were observed on the project site and no fluids were observed in the drums that were accessible. No other drums or storage containers, nor any open or damaged containers containing unidentified substances were observed at the project site. Additionally, no reports of spills or leaks were identified in the EDR report.

Surface Staining

No evidence of stained soil or pavement was observed on the project site.

Sewer/Water

No evidence of septic systems or wells was observed on the project site.

Suspect Polychlorinated Biphenyl (PCB) Containing Equipment

Pole-mounted sealed electrical transformers owned and maintained by the IID are located on the embankment of the All-American Canal adjacent to the farmyard of the project site. However, the IID has replaced all transformers that contained PCBs within recent years. Stickers were observed on the transformers that indicated that they had been tested for PCBs. No leaks were observed during the site reconnaissance.

Pesticides

Based on the review of environmental records, historical documents, and site conditions, the project site has been in agricultural use and/or vacant since the 1930s. Residues of currently available pesticides and currently banned pesticides, such as Dichlorodiphenyltrichloroethane/ Dichlorodiphenyldichloroethylene (DDT/DDE) may be present in near surface soils in limited concentrations.

Therefore, there is a potential for the project site to contain hazards related to pesticide and herbicide use from aerial and/or ground application which can migrate via surface run-off. The concentrations of these pesticides found on other Imperial Valley agricultural sites are typically less than 25 percent of the current regulatory threshold limits and are not considered a significant environmental hazard. The presence and concentration of near surface pesticides at the project site can be accurately characterized only by site-specific sampling and testing.

Lead and Asbestos

The potential for asbestos containing materials (ACM) and lead based paint residues existing at the project site is low due to the lack of structures other than the small masonry structure housing water pumps at the farmyard.

Airports

The project site is not located within 2 miles of a public airport or a public use airport. The nearest airports to the project site are the Calexico International Airport located approximately 10 miles west of the project site and Holtville Airport located approximately 10 miles north of the project site. According to the Imperial County Airports Department, the Holtville Airport is currently closed.

Fire Hazard

The project site is located in the unincorporated area of Imperial County. According to the Seismic and Public Safety Element of the General Plan, the potential for a major fire in the unincorporated areas of the County is generally low (County of Imperial 1997).

3.9.2 Regulatory Setting

This section identifies and summarizes federal, state, and local laws, policies, and regulations that are applicable to the project.

Federal

Comprehensive Environmental Response, Compensation, and Liability Act

The Comprehensive Environmental Response, Compensation, and Liability Act, commonly known as Superfund, was enacted by Congress on December 11, 1980. This law created a tax on the chemical and petroleum industries and provided broad federal authority to respond directly to releases or threatened releases of hazardous substances that may endanger public health or the environment. Over 5 years, \$1.6 billion was collected and the tax went to a trust fund for cleaning up abandoned or uncontrolled hazardous waste sites. The Comprehensive Environmental Response, Compensation, and Liability Act established prohibitions and requirements concerning closed and abandoned hazardous waste sites; provided for liability of persons responsible for releases of hazardous waste at these sites; and established a trust fund to provide for cleanup when no responsible party could be identified.

Emergency Planning Community Right-to-Know Act of 1986 (42 United States Code 11001 et seq.)

The Emergency Planning Community Right-to-Know Act was included under the Superfund Amendments and Reauthorization Act (SARA) law and is commonly referred to as SARA Title III.

Emergency Planning Community Right-to-Know was passed in response to concerns regarding the environmental and safety hazards posed by the storage and handling of toxic chemicals. These concerns were triggered by the disaster in Bhopal, India, in which more than 2,000 people suffered death or serious injury from the accidental release of methyl isocyanate. To reduce the likelihood of such a disaster in the U.S., Congress imposed requirements on both states and regulated facilities.

Emergency Planning Community Right-to-Know establishes requirements for federal, state, and local governments, Indian Tribes, and industry regarding emergency planning and “Community Right-to-Know” reporting on hazardous and toxic chemicals. SARA Title III requires states and local emergency planning groups to develop community emergency response plans for protection from a list of Extremely Hazardous Substances (40 CFR 355). The Emergency Planning Community Right-to-Know provisions help increase the public’s knowledge and access to information on chemicals at individual facilities, their uses, and releases into the environment. In California, SARA Title III is implemented through the California Accidental Release Prevention.

Federal Insecticide, Fungicide, and Rodenticide Act

The objective of Federal Insecticide, Fungicide, and Rodenticide Act is to provide federal control of pesticide distribution, sale, and use. All pesticides used in the U.S. must be registered (licensed) by the EPA. Registration assures that pesticides would be properly labeled and that, if used in accordance with specifications, they would not cause unreasonable harm to the environment. Use of each registered pesticide must be consistent with use directions contained on the label or labeling.

Federal Water Pollution Control Act (Clean Water Act)

The objective of the Federal Water Pollution Control Act, commonly referred to as the CWA, is to restore and maintain the chemical, physical, and biological integrity of the nation’s waters by preventing point and nonpoint pollution sources, providing assistance to publicly owned treatment works for the improvement of wastewater treatment, and maintaining the integrity of wetlands. The oil SPCC Program of the CWA specifically seeks to prevent oil discharges from reaching waters of the U.S. or adjoining shorelines. Further, farms are subject to the SPCC rule if they:

- Store, transfer, use, or consume oil or oil products
- Could reasonably be expected to discharge oil to waters of the U.S. or adjoining shorelines. Farms that meet these criteria are subject to the SPCC rule if they meet at least one of the following capacity thresholds:
 - Aboveground oil storage capacity greater than 1,320 gallons
 - Completely buried oil storage capacity greater than 42,000 gallons

However, the following are exemptions to the SPCC rule:

- Completely buried storage tanks subject to all the technical requirements of the underground storage tank regulations
- Containers with a storage capacity less than 55 gallons of oil
- Wastewater treatment facilities
- Permanently closed containers
- Motive power containers (e.g., automotive or truck fuel tanks)

Hazardous Materials Transport Act – Code of Federal Regulations

The Hazardous Materials Transportation Act was published in 1975. Its primary objective is to provide adequate protection against the risks to life and property inherent in the transportation of hazardous material in commerce by improving the regulatory and enforcement authority of the Secretary of Transportation. A hazardous material, as defined by the Secretary of Transportation is, any “particular quantity or form” of a material that “may pose an unreasonable risk to health and safety or property.”

Occupational Safety and Health Administration

Occupational Safety and Health Administration’s (OSHA) mission is to ensure the safety and health of America's workers by setting and enforcing standards; providing training, outreach, and education; establishing partnerships; and encouraging continual improvement in workplace safety and health. OSHA standards are listed in 29 CFR Part 1910.

The OSHA Process Safety Management of Highly Hazardous Chemicals (29 CFR Part 110.119) is intended to prevent or minimize the consequences of a catastrophic release of toxic, reactive, flammable, or explosive highly hazardous chemicals by regulating their use, storage, manufacturing, and handling. The standard intends to accomplish its goal by requiring a comprehensive management program integrating technologies, procedures, and management practices.

Resource Conservation and Recovery Act

The goal of the Resource Conservation and Recovery Act, a federal statute passed in 1976, is the protection of human health and the environment, the reduction of waste, the conservation of energy and natural resources, and the elimination of the generation of hazardous waste as expeditiously as possible. The Hazardous and Solid Waste Amendments of 1984 significantly expanded the scope of RCRA by adding new corrective action requirements, land disposal restrictions, and technical requirements. The corresponding regulations in 40 CFR 260-299 provide the general framework for managing hazardous waste, including requirements for entities that generate, store, transport, treat, and dispose of hazardous waste.

State

California Department of Conservation, Division of Oil, Gas, and Geothermal Resources

The Division of Oil, Gas, and Geothermal Resources was formed in 1915 to address the needs of the state, local governments, and industry by regulating statewide oil and gas activities with uniform laws and regulations. The Division supervises the drilling, operation, maintenance, and plugging and abandonment of onshore and offshore oil, gas, and geothermal wells, preventing damage to: (1) life, health, property, and natural resources; (2) underground and surface waters suitable for irrigation or domestic use; and (3) oil, gas, and geothermal reservoirs. The Division’s programs include: well permitting and testing; safety inspections; oversight of production and injection projects; environmental lease inspections; idle-well testing; inspecting oilfield tanks, pipelines, and sumps; hazardous and orphan well plugging and abandonment contracts; and subsidence monitoring.

California Department of Toxic Substances Control

DTSC regulates hazardous waste, cleans-up existing contamination, and looks for ways to reduce the hazardous waste produced in California. Approximately 1,000 scientists, engineers, and specialized support staff are responsible for ensuring that companies and individuals handle, transport, store, treat, dispose of, and clean up hazardous wastes appropriately. Through these measures, DTSC contributes to greater safety for all Californians, and less hazardous waste reaches the environment.

On January 1, 2003, the Registered Environmental Assessor program joined DTSC. The program certifies environmental experts and specialists as being qualified to perform a number of environmental assessment activities. Those activities include private site management, Phase I ESAs, risk assessment, and more.

California Division of Occupational Safety and Health

The California Division of Occupational Safety and Health protects workers and the public from safety hazards through its programs and provides consultative assistance to employers. California Division of Occupational Safety and Health issues permits, provides employee training workshops, conducts inspections of facilities, investigates health and safety complaints, and develops and enforces employer health and safety policies and procedures.

California Environmental Protection Agency

California Environmental Protection Agency and the SWRCB establish rules governing the use of hazardous materials and the management of hazardous waste. Applicable state and local laws include the following:

- Public Safety/Fire Regulations/Building Codes
- Hazardous Waste Control Law
- Hazardous Substances Information and Training Act
- Air Toxics Hot Spots and Emissions Inventory Law
- Underground Storage of Hazardous Substances Act
- Porter-Cologne Water Quality Control Act

Within Cal-EPA, DTSC has primary regulatory responsibility, with delegation of enforcement to local jurisdictions that enter into agreements with the state agency, for the management of hazardous materials and the generation, transport, and disposal of hazardous waste under the authority of the Hazardous Waste Control Law.

California Emergency Response Plan

California has developed an Emergency Response Plan to coordinate emergency services provided by federal, state, and local government and private agencies. Response to hazardous materials incidents is one part of this plan. The plan is managed by the State Office of Emergency Services (OES), which coordinates the responses of other agencies including Cal-EPA, the California Highway Patrol, CDFW, RWQCB, Imperial County Sheriff's Department, ICFD, and the City of Imperial Police Department.

Local

Imperial County General Plan

The Seismic and Public Safety Element identifies goals and policies that will minimize the risks associated with natural and human-made hazards and specify the land use planning procedures that should be implemented to avoid hazardous situations. The purpose of the Seismic and Public Safety Element is to reduce the loss of life, injury, and property damage that might result from disaster or accident. In addition, the Element specifies land use planning procedures that should be implemented to avoid hazardous situations. The policies listed in the Seismic and Public Safety Element are not applicable to the proposed project, as they address human occupancy development. The proposed project is a solar project and does not propose residential uses.

Imperial County Public Health Department

Hazardous Materials and Medical Waste Management

DTSC was appointed the Certified Unified Program Agency (CUPA) for Imperial County in January 2005. The Unified Program is the consolidation of 6 state environmental programs into one program under the authority of a CUPA. The CUPA inspects businesses or facilities that handle or store hazardous materials, generate hazardous waste, own or operate ASTs or USTs, and comply with the California Accidental Release Prevention Program. The CUPA Program is instrumental in accomplishing this goal through education, community and industry outreach, inspections and enforcement.

Office of Emergency Services

As part of the ICFD, the County OES is mandated by the California Emergency Services Act (Chapter 7, Division 1, Title 2 of Government Code) to serve as the liaison between the State and all the local government in the County. The OES provides centralized emergency management during major disasters, and coordinates emergency operations between various local jurisdictions within the County. The OES has developed several plans, consistent with federal and state policy guidance, to provide the County and participating local jurisdictions and agencies a framework for conducting emergency planning, response, and recovery operations, and handling of hazardous substances.

3.9.3 Impacts and Mitigation Measures

This section presents the significance criteria used for considering project-related impacts related to hazards and hazardous materials, the methodology employed for the evaluation, and mitigation requirements, if necessary.

Thresholds of Significance

Based on CEQA Guidelines Appendix G, project impacts related to hazards and hazardous materials are considered significant if any of the following occur:

- Create a significant hazard to the public or the environment through the routine transport, use, or disposal of hazardous materials
- Create a significant hazard to the public or the environment through reasonably foreseeable upset and accident conditions involving the release of hazardous materials into the environment

- Emit hazardous emissions or handle hazardous or acutely hazardous materials, substances, or waste within 0.25 mile of an existing or proposed school
- Be located on a site which is included on a list of hazardous materials sites compiled pursuant to Government Code Section 65962.5 and, as a result, would create a significant hazard to the public or the environment
- For a project located within an airport land use plan or, where such a plan has not been adopted, within 2 miles of a public airport or public use airport, result in a safety hazard or excessive noise for people residing or working in the project area
- Impair implementation of or physically interfere with an adopted emergency response plan or emergency evacuation plan
- Expose people or structures, either directly or indirectly, to a significant risk of loss, injury or death involving wildland fires

Methodology

This analysis evaluates the potential for the project, as described in Chapter 2, Project Description to result in significant impacts related to hazards and hazardous materials on or within the 1-mile buffer zone of the project site. This analysis considers whether these conditions would result in an exceedance of one or more of the applied significance criteria as identified above.

A Phase I ESA has been prepared for the project site. The information obtained from the Phase I ESA was reviewed and summarized to present the existing conditions, in addition to identifying potential environmental impacts, based on the significance criteria presented above. Impacts associated with hazards and hazardous materials that could result from project construction and operational activities were evaluated qualitatively based on site conditions; expected construction practices; materials, locations, duration of project construction, and related activities. The conceptual site plan (Figure 2-3) for the project was also used to evaluate potential impacts.

Impact Analysis

Impact 3.9-1 Would the project create a significant hazard to the public or the environment through the routine transport, use, or disposal of hazardous materials?

Although considered minimal, it is anticipated that the proposed project will generate the following materials during construction, operation, and long-term maintenance: insulating oil (used for electrical equipment), lubricating oil (used for maintenance vehicles), various solvents/detergents (equipment cleaning), and gasoline (used for maintenance vehicles). These materials have the potential to be released into the environment as a result of natural hazard (i.e., earthquake) related events, or because of human error. However, all materials contained on site will be stored in appropriate containers (not to exceed a 55-gallon drum) protected from environmental conditions, including rain, wind, and direct heat and physical hazards such as vehicle traffic and sources of heat and impact. In addition, if the on-site storage of hazardous materials necessitate, at any time during construction and/or operations and long-term maintenance, quantities in excess of 55-gallons, a hazardous material management program (HMMP) would be required. The HMMP developed for the project will include, at a minimum, procedures for:

- Hazardous materials handling, use and storage

- Emergency response
- Spill control and prevention
- Employee training
- Record keeping and reporting

Spill response plans would be developed prior to project construction and operation or prior to the storage on-site of an excess of 55 gallons of hazardous materials, and personnel would be made aware of the procedures for spill cleanup and the procedures to report a spill. Spill cleanup materials and equipment appropriate to the type and quantity of chemicals and petroleum products expected would be located onsite and personnel shall be made aware of their location.

The small quantities of chemicals to be stored at the project site during construction include equipment and facilities maintenance chemicals. These materials would be stored in their appropriate containers in an enclosed and secured location, such as portable outdoor hazardous materials storage cabinets equipped with secondary containment to prevent contact with rainwater. The portable chemical storage cabinets may be moved to different locations around the project site as construction activity locations shift. The chemical storage area would not be located immediately adjacent to any drainage. Disposal of excess materials and wastes would be performed in accordance with local, state, and federal regulations.

Additionally, hazardous material storage and management will be conducted in accordance with requirements set forth by the ICFD, Imperial County Office of Emergency Services, DTSC, and CUPA for storage and handling of hazardous materials. Further, construction activities would occur according to OSHA regulatory requirements; therefore, it is not anticipated that the construction activities for the proposed project would release hazardous emissions or result in the handling of hazardous or acutely hazardous materials, substances, or waste. This could include the release of hazardous emissions, materials, substances, or wastes during operational activities. With the implementation of an HMMP and adherence to requirements set forth by the ICFD, Imperial County Office of Emergency Services, DTSC, OSHA regulatory requirements and CUPA, the impact associated with the possible risk to the public or environment through routine transport, use, or disposal of hazardous materials would be considered less than significant.

Battery Energy Storage System

In conjunction with the construction of the solar facility, a 100 MW battery ESS will be constructed to store the energy generated by the solar panels on the northern boundary of APN 059-300-015. Transportation of hazardous materials relating to the battery ESS includes electrolyte and graphite and would occur during construction, operation (if replacement of batteries is needed) and decommissioning (removal of the batteries). All of these various materials would be transported and handled in compliance with DTSC regulations. Therefore, likelihood of an accidental release during transport or residual contamination following accidental release is not anticipated.

Lithium-ion batteries used in the storage system contain cobalt oxide, manganese dioxide, nickel oxide, carbon, electrolyte, and polyvinylidene fluoride. Of these chemicals, only electrolyte should be considered hazardous, inflammable and could react dangerously when mixed with water. The U.S. Department of Transportation (DOT) regulates transport of lithium-ion batteries under the DOT's Hazardous Materials Regulations (HMR; 49 C.F.R., Parts 171-180). The HMR apply to any material DOT determines is capable of posing an unreasonable risk to health, safety, and property when

transported in commerce. Lithium-ion batteries must conform to all applicable HMR requirements when offered for transportation or transported by air, highway, rail, or water (DOT 2021). Additionally, carbon (as graphite) is flammable and could pose a fire hazard. As further detailed below, fire protection is achieved through project design features, such as monitoring, diagnostics and a fire suppression system. The project would be required to comply with state laws and county ordinance restrictions, which regulate and control hazardous materials handled on site.

Construction wastes would be disposed of in accordance with local, state, and federal regulations, and recycling will be used to the greatest extent possible. In this context, with adherence to requirements set forth by the ICFD, Imperial County OES, DTSC, OSHA regulatory requirements and CUPA, impacts would be less than significant.

Mitigation Measure(s)

No mitigation measures are required.

Impact 3.9-2 Would the project create a significant hazard to the public or the environment through reasonably foreseeable upset and accident conditions involving the release of hazardous materials into the environment?

According to the historical records search, the project site has been in agricultural use and/or vacant since the 1930s. Typical agricultural practices in the Imperial Valley consist of aerial and ground application of pesticides and the application of chemical fertilizers to both ground and irrigation water. GS Lyon professionals have reported that concentrations of pesticides are limited and typically less than 25 percent of the current regulatory threshold limits of EPA preliminary remediation goals.

The Federal Insecticide, Fungicide, and Rodenticide Act provides federal control of pesticide distribution, sale, and use. Pesticides used in the United States must be registered by the EPA to assure that pesticides are properly labeled and that they will not cause unreasonable harm to the environment. The construction phase, operations and long-term maintenance of the facility would not result in additional application of pesticides or fertilizers. Therefore, a less than significant impact has been identified for this issue area.

Hazardous Materials

The Phase I ESA (Appendix H of this EIR) prepared for the project site did not identify any recognized environmental conditions (RECs) or USTs. According to the local DTSC record searches and interviews with individuals familiar with the subject property, there are no potential RECs existing on the project site. However, one AST was observed within the fenced farmyard within the project site. Access to the AST was not available at the time of the site reconnaissance. If it is shown that spills or leaks had occurred, the affected soil shall be cleaned up and properly disposed according to the HMMP. Several steel 55-gallon drums were also observed on the subject property and no fluids were observed in the drums that were accessible. No other drums or storage containers, nor any open or damaged containers containing unidentified substances were observed at the project site. With adherence to requirements set forth by the ICFD, Imperial County Office of Emergency Services, DTSC, OSHA regulatory requirements and CUPA, impacts would be less than significant.

Lead and Asbestos

According to records research and the reconnaissance survey, the potential for lead-based paint residues and asbestos containing materials is very low because of the lack of site development. Therefore, a less than significant impact is identified for this issue area.

Battery Energy Storage System

Protection would be provided as part of the project design by housing the battery units in enclosed structures to provide containment should a fire break out or for potential spills. Any potential fire risk that the traditional lithium-ion cells have will most likely be caused by over-charging or through short circuit due to age. This risk will be mitigated through monitoring and a fire suppression system that includes water and or a suppression agent (eg FM-200, Novatech) with smoke detectors, control panel, alarm, piping and nozzles. The fire protection system will be designed by a certified fire protection engineer and installed by a fire protection system contractor licensed in California and in accordance with all relevant building and fire codes in effect in the County at the time of building permit submission. Fire protection systems for battery systems would be designed in accordance with California Fire Code and would take into consideration the recommendations of the National Fire Protection Association (NFPA) 855.

The fire protection plan is anticipated to include a combination of prevention, suppression, and isolation methods and materials. The general approach to fire mitigation at the project site would be prevention of an incident, followed by attempts to isolate and control the incident to the immediately affected equipment, then to suppress any fire with a clean agent so as to reduce damage to uninvolved equipment. Fire suppression agents such as Novec 1230 or FM 2000, or water may be used as a suppressant. In addition, fire prevention methods would be implemented to reduce potential fire risk, including voltage, current, and temperature alarms. Energy storage equipment would comply with Underwriters Laboratory (UL)-95401 and test methods associated with UL-9540A. For lithium-ion batteries storage, a system would be used that would contain the fire event and encourage suppression through cooling, isolation, and containment. Suppressing a lithium-ion (secondary) battery is best accomplished by cooling the burning material. A gaseous fire suppressant agent (e.g., 3M™ Novec™ 1230 Fire Protection Fluid or similar) and an automatic fire extinguishing system with sound and light alarms would be used for lithium-ion batteries.

To mitigate potential hazards, redundant separate methods of failure detection would be implemented. These would include alarms from the Battery Management System (BMS), including voltage, current, and temperature alarms. Detection methods for off gas detection would be implemented, as applicable. These are in addition to other potential protective measures such as ventilation, overcurrent protection, battery controls maintaining batteries within designated parameters, temperature and humidity controls, smoke detection, and maintenance in accordance with manufacturer guidelines. Remote alarms would be installed for operations personnel as well as emergency response teams in addition to exterior hazard lighting. In addition, an Incidence Response Plan would be implemented. In this context, impacts would be considered less than significant for this impact area.

Mitigation Measure(s)

No mitigation measures are required.

Impact 3.9-3 Would the project emit hazardous emissions or handle hazardous or acutely hazardous materials, substances, or waste within 0.25 mile of an existing or proposed school?

The project site is not located within 0.25 mile of any existing or proposed schools. Therefore, the proposed project would not pose a risk to nearby schools and no impact would occur.

Mitigation Measure(s)

No mitigation measures are required.

Impact 3.9-4 Would the project be located on a site which is included on a list of hazardous materials sites compiled pursuant to Government Code Section 65962.5 and, as a result, would create a significant hazard to the public or the environment?

The project site is not identified in the EDR report as being located on a hazardous materials site pursuant to Government Code Section 65962.5. Implementation of the proposed project would result in no impact related to the project site being located on a listed hazardous materials site.

Mitigation Measure(s)

No mitigation measures are required.

Impact 3.9-5 For a project located within an airport land use plan or, where such a plan has not been adopted, within 2 miles of a public airport or public use airport, result in a safety hazard or excessive noise for people residing or working in the project area?

The project site is not located within 2 miles of a public airport. The nearest airports to the project site are the Calexico International Airport located approximately 10 miles west of the project site and Holtville Airport located approximately 10 miles north of the project site. According to the Imperial County Airports Department, the Holtville Airport is currently closed. According to Figure 3B of the ALUCP, no portion of the project site is located within the Calexico International Airport's land use compatibility zones (County of Imperial 1996). Therefore, implementation of the proposed project would not result in a safety hazard or excessive noise for people residing or working in the project area and no impact would occur.

Mitigation Measure(s)

No mitigation measures are required.

Impact 3.9-6 Would the project impair implementation of or physically interfere with an adopted emergency response plan or emergency evacuation plan?

The Imperial County Operational Area Emergency Operations Plan (Imperial County OES 2016) does not identify specific emergency roadway routes as part of their emergency operations plan (EOP). The Circulation & Scenic Highways Element of the General Plan (County of Imperial 2008) identifies SR-98 and SR-7/S-32, which are adjacent to the project site and provide regional and local connections, as major access routes and corridors.

The applicant for the proposed project will be required, through the conditions of approval, to prepare a street improvement plan for the project that will include emergency access points and safe vehicular travel. Additionally, local building codes would be followed to minimize flood, seismic, and fire hazard. Therefore, the proposed project would result in a less than significant impact associated with the possible impediment to emergency response plans or emergency evacuation plans.

Mitigation Measure(s)

No mitigation measures are required.

Impact 3.9-7 Would the project expose people or structures, either directly or indirectly, to a significant risk of loss, injury or death involving wildland fires?

The project site is located in the unincorporated area of Imperial County. According to the Seismic and Public Safety Element of the General Plan (County of Imperial 1997), the potential for a major fire in the unincorporated areas of the County is generally low.

Proposed project facilities would be designed, constructed, and operated in accordance with applicable fire protection and other environmental, health, and safety requirements (e.g., CPUC safety standards). PV panels would be spaced to maintain proper clearance for emergency access. Internal access roads, up to 30-foot wide, would be constructed along the perimeter fence and solar panels to facilitate vehicle access and maneuverability for emergency unit vehicles. Access roads would be graded and compacted (native soils) as required for construction, operations, maintenance, and emergency vehicle access. The access and service roads would also have turnaround areas at any dead-end to allow clearance for fire trucks per fire department standards. The access and service roads would also have turnaround areas at any dead-end to allow clearance for fire trucks per fire department standards.

Because the proposed project is not located in proximity to an area susceptible to wildland fires, implementation of the proposed project would result in a less than significant impact related to the possible risk to people or structures caused by wildland fires.

Mitigation Measure(s)

No mitigation measures are required.

3.9.4 Decommissioning/Restoration and Residual Impacts

Decommissioning/Restoration

During decommissioning and restoration of the project site, the applicant or its successor in interest would be responsible for the removal, recycling, and/or disposal of all solar arrays, inverters, battery storage system, transformers and other structures on each of the project site. The project applicant anticipates using the best available recycling measures at the time of decommissioning. Any potentially hazardous materials located on the site would be disposed of, and/or remediated prior to construction of the solar facilities.

The operation of the solar facility would not generate hazardous wastes and therefore, implementation of applicable regulations and mitigation measures identified for construction and operations would ensure restoration of the project site to pre-project conditions during the decommissioning process in a manner that would be less than significant. Furthermore, decommissioning/restoration activities would not result in a potential impact associated with ALUCP

consistency (structures would be removed and the site would remain in an undeveloped condition), wildfires (fire protection measures), or impediment to an emergency plan (the undeveloped condition as restored, would not conflict with emergency plans).

Residual

Adherence to federal, state, and local regulations will ensure that impacts related to the transportation of hazardous materials and potential fires would be reduced to levels less than significant. Based on these circumstances, the proposed project would not result in residual significant and unmitigable impacts related to hazards and hazardous materials.

3.10 Hydrology/Water Quality

This section provides a description of existing water resources within the project site and pertinent local, state, and federal plans and policies. Each subsection includes descriptions of existing hydrology/drainage, existing flooding hazards, and the environmental impacts on hydrology and water quality resulting from implementation of the proposed project, and mitigation measures where appropriate. The impact assessment provides an evaluation of potential effects to water quality based on criteria derived from CEQA Guidelines in conjunction with actions proposed in Chapter 2, Project Description.

3.10.1 Existing Conditions

Drainage

The project site is located in the Imperial Valley Planning Area of the Colorado River Basin. The Colorado River Basin Region covers approximately 13 million acres (20,000 square miles) in the southeastern portion of California. It includes all of Imperial County and portions of San Bernardino, Riverside, and San Diego Counties. The Colorado River Basin Region is divided into seven major planning areas on the basis of different economic and hydrologic characteristics (California RWQCB 2019). The Imperial Valley Planning Area consists of the following HUs: Imperial (723.00) comprised of 2,500 square miles in the southern portion of the Colorado River Basin Region, with the majority located in Imperial County; Davies (724.00), and Amos-Ogilby (726.00). The project site is located within the Imperial HU.

The Imperial HU consists of the majority of the Imperial Valley, encompassing over 1.3 million acres of land. The watershed includes vast acreages of agricultural land; towns such as El Centro, Calexico, and Brawley, along with a large network of IID operated canals and drains. The watershed is atypical of most watersheds in California, as it currently and historically has been shaped by man-made forces. The watershed's primary watercourses, the New and Alamo rivers, flow north, from the Mexican border toward their final destination, the Salton Sea. The Salton Sea, a 376 square mile closed inland lake was created in 1905 through a routing mistake and subsequent flood on the Colorado River. The sea has been fed primarily by agricultural runoff from the New and Alamo Rivers ever since that time.

The project site is within the Salton Sea watershed, Hydrologic Unit Code 18100204. The project site is downslope of the All-American Canal, which brings water from the Colorado River at the Imperial Dam, and then supplies it to the Imperial Valley through smaller lateral canals, all of which drain to the Salton Sea.

Runoff from adjacent agricultural land collects and is concentrated in the project site. Runoff within the project site generally flows south from the direction of the All-American Canal, toward the U.S.-Mexico border, and eventually drains into a playa at the south end of the site. Manmade berms running north-south line ephemeral drainages present throughout the western portion of the project site. The All-American Canal and groundwater likely feed the drainages and wetlands present onsite.

Flooding

According to the Federal Emergency Management Agency (FEMA) Flood Insurance Rate Map (Panel 06025C2125C) (FEMA 2008), the project site is within Zone X, which is an area determined to be outside of the 0.2 percent annual chance of a flood.

Surface Water Quality

The surface waters of the Imperial Valley depend primarily on the inflow of irrigation water from the Colorado River via the All-American Canal. Excessive salinity concentrations have long been one of the major water quality problems of the Colorado River, a municipal and industrial water source to millions of people, and a source of irrigation water for approximately 700,000 acres of farmland. The heavy salt load in the Colorado River results from both natural and human activities. Land use and water resources are unequivocally linked. A variety of natural and human factors can affect the quality and use of streams, lakes, and rivers. Surface waters may be impacted from a variety of point and non-point discharges. Examples of point sources may include wastewater treatment plants, industrial discharges, or any other type of discharge from a specific location (commonly a large-diameter pipe) into a stream or water body. In contrast, non-point source pollutant sources are generally more diffuse in nature and connected to a cumulative contribution of multiple smaller sources.

Common non-point source contaminants within the project area may include, but are not limited to: sediment, nutrients (phosphorous and nitrogen), trace metals (e.g., lead, zinc, copper, nickel, iron, cadmium, and mercury), oil and grease, bacteria (e.g., coliform), viruses, pesticides and herbicides, organic matter, and solid debris/litter. Vehicles account for most of the heavy metals, fuel and fuel additives (e.g., benzene), motor oil, lubricants, coolants, rubber, battery acid, and other substances. Nutrients result from excessive fertilizing of agricultural areas, while pesticides and herbicides are widely used in agricultural fields and roadway shoulders for keeping right-of-way (ROW) areas clear of vegetation and pests.

Based on the 305(b)/303(d) Integrated Report prepared by the Colorado River Basin RWQCB (RWQCB 2018), the following water features within the Brawley Hydrologic Area includes the Imperial Valley Drains (Wistaria Drain and Greeson Wash), New River, and the Salton Sea. Specific impairments listed for each of these water bodies (or Category 5) are identified below:

- Imperial Valley Drains: Impaired for pesticides (toxaphene, chlorpyrifos, dieldrin, chlordane, dichlorodiphenyltrichloroethane, and imidacloprid), metals (selenium), sediment/siltation, total toxics, and organic toxics (polychlorinated biphenyls);
- New River: Impaired for pesticides (toxaphene, chlorpyrifos, dieldrin, chlordane, hexachlorobenzene, dichlorodiphenyltrichloroethane, diazinon, cyhalothrin, lambda, cypermethrin, bifenthrin, malathion, disulfoton, imidacloprid), metals (selenium and mercury), sediment/siltation, nutrients (organic enrichment), trash, pathogens (indicator bacteria), organic toxics (polychlorinated biphenyls and naphthalene), total toxics, and dissolved salts (chloride);
- All-American Canal: Impaired for pesticides (dichlorodiphenyltrichloroethane);
- Salton Sea: pesticides (chlorpyrifos and dichlorodiphenyltrichloroethane), metals (arsenic), pathogens (Enterococcus), nutrients (ammonia and low dissolved oxygen), total toxics, and dissolved salts (chloride).

Groundwater Hydrology

The project site is located within the Imperial Valley Groundwater Basin (Basin No: 7-30), which covers approximately 1,870 surface square miles. The physical groundwater basin extends in the southeastern portion of California at the border with Mexico. The basin lies within the southern part of the Colorado Desert Hydrologic Region, south of the Salton Sea. The basin has two major

aquifers, separated at depth by a semi-permeable aquitard that averages 60 feet thick and reaches a maximum thickness of 280 feet. The average thickness of the upper aquifer is 200 feet with a maximum thickness of 450 feet. The data regarding faults controlling groundwater movement is uncertain; however, as much as 80 feet of fine-grained, low permeability prehistoric lake deposits have accumulated on the valley floor, which result in locally confined aquifer conditions.

Groundwater recharge within the basin is primarily from irrigation return. Other recharge sources are deep percolation of rainfall and surface runoff, underflow into the basin, and seepage from unlined canals which traverse the valley. Groundwater levels within a majority of the basin have remained stable from 1970 to 1990 because of relatively constant recharge and an extensive network of subsurface drains.

Groundwater quality varies extensively throughout the base; however, is generally unusable for domestic and irrigation purposes without treatment (California Department of Water Resources 2004).

3.10.2 Regulatory Setting

This section identifies and summarizes federal, state, and local laws, policies, and regulations that are applicable to the project.

Federal

Clean Water Act

The U.S. EPA is the lead federal agency responsible for managing water quality. The CWA of 1972 is the primary federal law that governs and authorizes the U.S. EPA and the states to implement activities to control water quality. The various elements of the CWA that address water quality and that are applicable to the project are discussed below. Wetland protection elements administered by the USACE under Section 404 of the CWA, including permits for the discharge of dredged and/or fill material into waters of the United States, are discussed in Section 3.5, Biological Resources.

Under federal law, the U.S.EPA has published water quality regulations under Volume 40 of the CFR. Section 303 of the CWA requires states to adopt water quality standards for all surface waters of the U.S. As defined by the CWA, water quality standards consist of two elements: (1) designated beneficial uses of the water body in question; and (2) criteria that protect the designated uses. Section 304(a) requires the U.S.EPA to publish advisory water quality criteria that accurately reflect the latest scientific knowledge on the kind and extent of all effects on health and welfare that may be expected from the presence of pollutants in water. Where multiple uses exist, water quality standards must protect the most sensitive use. The U.S. EPA is the federal agency with primary authority for implementing regulations adopted under the CWA. The U.S.EPA has delegated the State of California the authority to implement and oversee most of the programs authorized or adopted for CWA compliance through the Porter-Cologne Water Quality Control Act of 1969 (Porter-Cologne Act), described below.

Under CWA Section 401, applicants for a federal license or permit to conduct activities that may result in the discharge of a pollutant into waters of the U.S. must obtain a water quality certification from the SWRCB in which the discharge would originate or, if appropriate, from the interstate water pollution control agency with jurisdiction over affected waters at the point where the discharge would originate.

CWA Section 402 establishes the National Pollution Discharge Elimination System (NPDES) permit program to control point source discharges from industrial, municipal, and other facilities if their discharges go directly to surface waters. The 1987 amendments to the CWA created a new section of the CWA devoted to regulating storm water or nonpoint source discharges (Section 402[p]). The U.S.EPA has granted California primacy in administering and enforcing the provisions of the CWA and the NPDES program through the SWRCB. The SWRCB is responsible for issuing both general and individual permits for discharges from certain activities. At the local and regional levels, general and individual permits are administered by RWQCBs.

Clean Water Act Section 303(d) Impaired Waters List

CWA Section 303(d) requires states to develop lists of water bodies that will not attain water quality standards after implementation of minimum required levels of treatment by point-source dischargers. Section 303(d) requires states to develop a total maximum daily load (TMDL) for each of the listed pollutants and water bodies. A TMDL is the amount of loading that the water body can receive and still be in compliance with applicable water quality objectives and applied beneficial uses. TMDLs can also act as a planning framework for reducing loadings of a specific pollutant from various sources to achieve compliance with water quality objectives. TMDLs prepared by the state must include an allocation of allowable loadings to point and nonpoint sources, with consideration of background loadings and a margin of safety. The TMDL must also include an analysis that shows links between loading reductions and the attainment of water quality objectives.

National Flood Insurance Program

The Federal Emergency Management Agency (FEMA) administers the National Flood Insurance Program (NFIP) to provide subsidized flood insurance to communities that comply with FEMA regulations that limit development in floodplains. FEMA also issues Flood Insurance Rate Maps (FIRM) that identify which land areas are subject to flooding. These maps provide flood information and identify flood hazard zones in the community. The design standard for flood protection covered by the FIRM is established by FEMA, with the minimum level of flood protection for new development determined to be the 1-in-100 (0.01) annual exceedance probability) (i.e., the 100-year flood event).

State

Porter-Cologne Water Quality Control Act

The Porter-Cologne Water Quality Control Act, also known as the California Water Code, is California's statutory authority for the protection of water quality. Under this act, the state must adopt water quality policies, plans, and objectives that protect the state's waters. The act sets forth the obligations of the State Water Resources Control Board (SWRCB) and RWQCBs pertaining to the adoption of Water Quality Control Plans and establishment of water quality objectives. Unlike the CWA, which regulates only surface water, the Porter-Cologne Act regulates both surface water and groundwater.

Water Quality Control Plan for the Colorado River Basin

The Water Quality Control Plan for the Colorado River Basin (or Basin Plan) prepared by the Colorado River RWQCB (Region 7) identifies beneficial uses of surface waters within the Colorado River Basin region, establishes quantitative and qualitative water quality objectives for protection of

beneficial uses, and establishes policies to guide the implementation of these water quality objectives.

Water bodies that have beneficial uses that may be affected by construction activity and post-construction activity include the Imperial Valley Drains and the Salton Sea. Table 3.10-1 identifies the designated beneficial uses established for the project site’s receiving waters. The following are definitions of the applicable beneficial uses:

- Aquaculture (AQUA) – Uses of water for aquaculture or mariculture operations including, but not limited to, propagation, cultivation, maintenance, or harvesting of aquatic plants and animals for human consumption or bait purposes.
- Freshwater Replenishment (FRSH) – Uses of water for natural or artificial maintenance of surface water quantity or quality.
- Industrial Service Supply (IND) – Uses of water for industrial activities that do not depend primarily on water quality including, but not limited to, mining, cooling water supply, hydraulic conveyance, gravel washing, fire protection, and oil well repressurization.
- Water Contact Recreation (REC I) – Uses of water for recreational activities involving body contact with water, where ingestion of water is reasonably possible. These uses include, but are not limited to, swimming, wading, water-skiing, skin and scuba diving, surfing, white water activities, fishing, and use of natural hot springs.
- Non-contact Water Recreation (REC II) – Uses of water for recreational activities involving proximity to water, but not normally involving contact with water where ingestion of water is reasonably possible. These uses include, but are not limited to, picnicking, sunbathing, hiking, beachcombing, camping, boating, tide pool and marine life study, hunting, sightseeing, or aesthetic enjoyment in conjunction with the above activities.
- Warm Freshwater Habitat (WARM) – Uses of water that support warm water ecosystems including, but not limited to, preservation or enhancement of aquatic habitats, vegetation, fish, or wildlife, including invertebrates.
- Wildlife Habitat (WILD) – Uses of water that support terrestrial ecosystems including, but not limited to, the preservation and enhancement of terrestrial habitats, vegetation, wildlife (e.g., mammals, birds, reptiles, amphibians, invertebrates), or wildlife water and food sources.
- Preservation of Rare, Threatened, or Endangered Species (RARE) – Uses of water that support habitats necessary, at least in part, for the survival and successful maintenance of plant or animal species established under state or federal law as rare, threatened or endangered.

Table 3.10-1. Beneficial Uses of Receiving Waters

Beneficial Uses	Imperial Valley Drains	Salton Sea
AQUA	--	X
FRSH	X	--
IND	--	P
REC I	X	X
REC II	X	X

Table 3.10-1. Beneficial Uses of Receiving Waters

Beneficial Uses	Imperial Valley Drains	Salton Sea
WARM	X	X
WILD	X	X
RARE	X	X

Source: SWRCB 2019

AQUA=aquaculture; FRSH=freshwater replenishment; IND=industrial service supply; P=Potential Uses; RARE=Preservation of Rare, Threatened, or Endangered Species; REC 1= water contact recreation; REC II=non-contact water recreation; WARM=Warm Freshwater Habitat; WILD=Wildlife Habitat; X=existing beneficial uses

National Pollution Discharge Elimination System General Industrial and Construction Permits

The NPDES General Industrial Permit requirements apply to the discharge of stormwater associated with industrial sites. The permit requires implementation of management measures that will achieve the performance standard of the best available technology economically achievable and best conventional pollutant control technology. Under the statute, operators of new facilities must implement industrial BMPs in the projects' SWPPP and perform monitoring of stormwater discharges and unauthorized non-stormwater discharges.

Construction activities are regulated under the NPDES General Permit for Discharges of Storm Water Runoff Associated with Construction Activity (General Construction Permit) which covers stormwater runoff requirements for projects where the total amount of ground disturbance during construction exceeds 1 acre. Coverage under a General Construction Permit requires the preparation of a SWPPP and submittal of a Notice of Intent (NOI) to comply with the General Construction Permit. The SWPPP includes a description of BMPs to minimize the discharge of pollutants from the sites during construction. Typical BMPs include temporary soil stabilization measures (e.g., mulching and seeding), storing materials and equipment to ensure that spills or leaks cannot enter the storm drain system or stormwater, and using filtering mechanisms at drop inlets to prevent contaminants from entering storm drains. Typical post-construction management practices include street sweeping and cleaning stormwater drain inlet structures. The NOI includes site-specific information and the certification of compliance with the terms of the General Construction Permit.

Local

County of Imperial General Plan

The Water Element and the Conservation and Open Space Element of the General Plan contain policies and programs, created to ensure water resources are preserved and protected. Table 3.10-2 identifies the General Plan policies and programs for water quality and flood hazards that are relevant to the project and summarizes the project's consistency with the General Plan. While this EIR analyzes the project's consistency with the General Plan pursuant to CEQA Guidelines Section 15125(d), the Imperial County Board of Supervisors ultimately determines consistency with the General Plan.



Table 3.10-2. Project Consistency with Applicable General Plan Policies

General Plan Policies	Consistency with General Plan	Analysis
Conservation and Open Space Element		
<p>Goal 6: The County will conserve, protect, and enhance water resources in the County.</p>	<p>Consistent</p>	<p>The proposed project would protect water quality during construction through compliance with Imperial County design and detention requirements and the NPDES General Construction Permit, as well as preparation and implementation of a project-specific SWPPP, which will incorporate the requirements referenced in the State Regulatory Framework, design features, and BMPs.</p>
<p>Objective 6.3: Protect and improve water quality and quantity for all water bodies in Imperial County.</p>	<p>Consistent</p>	<p>The proposed project would protect water quality during construction through compliance with the NPDES General Construction Permit, SWPPP, and BMPs. Implementation of Mitigation Measure HYD-2 would require the project to incorporate post-construction BMPs into the proposed project's drainage plans. The proposed project will be designed to include site design, source control, and treatment control BMPs. The use of source control, site design, and treatment BMPs would result in a decrease potential for storm water pollution.</p>
<p>Program: Structural development normally shall be prohibited in the designated floodways. Only structures which comply with specific development standards should be permitted in the floodplain.</p>	<p>Consistent</p>	<p>The proposed project does not contain a residential component, nor would it place housing or other structures within a 100-year flood hazard area.</p>
Water Element		
<p>Policy: Adoption and implementation of ordinances, policies, and guidelines which assure the safety of County ground and surface waters from toxic or hazardous materials and/or wastes.</p>	<p>Consistent</p>	<p>The project would preserve ground and surface water quality from hazardous materials and wastes during construction, operation and decommissioning activities. The proposed project would protect water quality during construction through compliance with NPDES General Construction Permit SWPPP, which will incorporate the requirements referenced in the State Regulatory Framework and BMPs. Implementation of Mitigation Measure HYD-2 would require the project to incorporate post-construction BMPs into the project's drainage plan. The proposed project will be designed to include site design, source control, and treatment control BMPs. The use of source control, site design, and treatment BMPs would result in a decrease potential for storm water pollution. It is anticipated that decommissioning activities would be subject to similar, or more stringent ground and surface water regulations than those currently required.</p>

Table 3.10-2. Project Consistency with Applicable General Plan Policies

General Plan Policies	Consistency with General Plan	Analysis
Program: The County of Imperial shall make every reasonable effort to limit or preclude the contamination or degradation of all groundwater and surface water resources in the County.	Consistent	Mitigation measures will require that the applicant of the proposed project prepare a site-specific drainage plan and water quality management plan to minimize adverse effects to local water resources.
Program: All development proposals brought before the County of Imperial shall be reviewed for potential adverse effects on water quality and quantity and shall be required to implement appropriate mitigation measures for any significant impacts.	Consistent	See response for Water Element Policy above.

Source: County of Imperial 2016; County of Imperial 1997b

County of Imperial Land Use Ordinance, Title 9

The County’s Ordinance Code provides specific direction for the protection of water resources. Applicable ordinance requirements are contained in Division 10, Building, Sewer and Grading Regulations, and summarized below.

Chapter 10 – Grading Regulations. Section 91010.02 of the Ordinance Code outlines conditions required for issuance of a Grading Permit. These specific conditions include:

1. If the proposed grading, excavation or earthwork construction is of irrigatable land, said grading will not cause said land to be unfit for agricultural use.
2. The depth of the grading, excavation or earthwork construction will not preclude the use of drain tiles in irrigated lands.
3. The grading, excavation or earthwork construction will not extend below the water table of the immediate area.
4. Where the transition between the grading plane and adjacent ground has a slope less than the ratio of 1.5 feet on the horizontal plane to 1 foot on the vertical plane, the plans and specifications will provide for adequate safety precautions.

Imperial County Engineering Design Guidelines Manual for the Preparation and Checking of Street Improvement, Drainage and Grading Plans within Imperial County

Based on the guidance contained in the County’s *Engineering Guidelines Design Guidelines Manual for the Preparation and Checking of Street Improvement, Drainage and Grading Plans within Imperial County* (2008), the following drainage requirements would be applicable to the proposed projects.

III A. GENERAL REQUIREMENTS

1. All drainage design and requirements are recommended to be in accordance with the IID “Draft” Hydrology Manual or other recognized source with approval by the County Engineer and based on full development of upstream tributary basins. Another source is the Caltrans I-D-F curves for the Imperial Valley.

3. Permanent drainage facilities and ROW, including access, shall be provided from development to point of satisfactory disposal.
4. Retention volume on retention or detention basins should have a total volume capacity for a three (3) inch minimum precipitation covering the entire site with no C reduction factors. Volume can be considered by a combination of basin size and volume considered within parking and/or landscaping areas.

There is no guarantee that a detention basin outletting to an IID facility or other storm drain system will not back up should the facility be full and unable to accept the project runoff. This provides the safety factor from flooding by ensuring each development can handle a minimum 3-inch precipitation over the project site.

8. The developer shall submit a drainage study and specifications for improvements of all drainage easements, culverts, drainage structures, and drainage channels to the Department of Public Works for approval. Unless specifically waived herein, required plans and specifications shall provide a drainage system capable of handling and disposing of all surface waters originating within the subdivision and all surface waters that may flow onto the subdivision from adjacent lands. Said drainage system shall include any easements and structures required by the Department of Public Works or the affected Utility Agency to properly handle the drainage on-site and off-site. The report should detail any vegetation and trash/debris removal, as well as address any standing water.
9. Hydrology and hydraulic calculations for determining the storm system design shall be provided to the satisfaction of the Director, Department of Public Works. When appropriate, water surface profiles and adequate field survey cross-section data may also be required.
11. The County is implementing a storm water quality program as required by the SWRCB, which may modify or add to the requirements and guidelines presented elsewhere in this document. This can include ongoing monitoring of water quality of storm drain runoff, implementation of BMPs to reduce storm water quality impacts downstream or along adjacent properties. Attention is directed to the need to reduce any potential of vectors, mosquitoes, or standing water.
12. A Drainage Report is required for all developments in the County. It shall include a project description, project setting including discussions of existing and proposed conditions, any drainage issues related to the site, summary of the findings or conclusions, off-site hydrology, onsite hydrology, hydraulic calculations and a hydrology map.

Imperial Irrigation District

The IID is an irrigation district organized under the California Irrigation District Law, codified in Section 20500 et seq. of the California Water Code. Critical functions of IID include diversion and delivery of Colorado River water to the Imperial Valley, operation and maintenance of the drainage canals and facilities, including those in the project area, and generation and distribution of electricity. Several policy documents govern IID operations and are summarized below:

- The Law of the River and historical Colorado River decisions, agreements and contracts
- The Quantification Settlement Agreement and Transfer Agreements

- The Definite Plan, now referred to as the Systems Conservation Plan, which defines the rigorous agricultural water conservation practices being implemented by growers and IID to meet the Quantification Settlement Agreement commitments
- The Equitable Distribution Plan, which defines how IID will prevent overruns and stay within the cap on the Colorado River water rights
- Existing IID standards and guidelines for evaluation of new development and define IID's role as a responsible agency and wholesaler of water

Integrated Water Resources Management Plan

In relation to the project, IID maintains regulation over the drainage of water into their drains, including the design requirements of stormwater retention basins. IID requires that retention basins be sized to handle an entire rainfall event in case the IID system is at capacity. Additionally, IID requires that outlets to IID facilities be no larger than 12 inches in diameter and must contain a backflow prevention device (IID 2009).

3.10.3 Impacts and Mitigation Measures

Thresholds of Significance

Based on CEQA Guidelines Appendix G, project impacts related to hydrology/water quality are considered significant if any of the following occur:

- Violate any water quality standards or waste discharge requirements or otherwise substantially degrade groundwater water quality
- Substantially decrease groundwater supplies or interfere substantially with groundwater recharge such that the project may impede sustainable groundwater management of the basin
- Substantially alter the existing drainage pattern of the site or area, including through the alteration of the course of a stream or river or through the addition of impervious surfaces, in a manner which would:
 - Result in substantial erosion or siltation on- or off-site
 - Substantially increase the rate or amount of surface runoff in a manner which would result in flooding on- or offsite
 - Create or contribute runoff water which would exceed the capacity of existing or planned stormwater drainage systems or provide substantial additional sources of polluted runoff
 - Impede or redirect flood flows
- In flood hazard, tsunami, or seiche zones, risk release of pollutants due to project inundation
- Conflict with or obstruct implementation of a water quality control plan or sustainable groundwater management plan

Methodology

The drainage design will be conducted in accordance with the County of Imperial's design criteria, which establishes that 100 percent of the 100-year storm (3 inches of rain) will be stored on-site and



released into the IID drainage system using existing drainage connections. Specifically, the project site will be surrounded by a levee system designed to divert stormwater, including stormwater from a 100-year storm event. Diverted stormwater will be channeled to designated retention areas adjacent to the All-American Canal, thus protecting the solar array (see Appendix I, Drainage Plan).

Impact Analysis

Impact 3.10-1 *Would the project violate any water quality standards or waste discharge requirements or otherwise substantially degrade groundwater water quality?*

Construction

Construction of the proposed project would include site preparation, foundation construction, erection of major equipment and structures, installation of electrical systems, control systems, and startup/ testing. In addition, the construction of transmission lines, utility pole pads, conductors, and associated structures will be required.

During the construction phase, sedimentation and erosion can occur because of tracking from earthmoving equipment, erosion and subsequent runoff of soil, or improperly designed stockpiles. The utilization of proper erosion and sediment control BMPs is critical in preventing discharge to surface waters/drains. The project would employ proper SWPPP practices to minimize any discharges in order to meet the Best Available Technology/Best Conventional Technology standard set forth in the Construction General Permit.

Many different types of hazardous compounds will be used during the construction phase, with proper application, management, and containment being of high importance. Poorly managed construction materials can lead to the possibility for exposure of potential contaminants to precipitation. When this occurs, these visible and/or non-visible constituents become entrained in storm water runoff. This potential impact is considered a significant impact. With the implementation of Mitigation Measure HYD-1, impacts on surface water quality as attributable to the project would be reduced to a level less than significant. Prior to construction and grading activities, the project applicant is required to file an NOI with the SWRCB to comply with the General NPDES Construction Permit and prepare a SWPPP, which addresses the measures that would be included during construction or the project to minimize and control construction and post-construction runoff to the “maximum extent practicable.” In addition, NPDES permits require the implementation of BMPs that achieve a level of pollution control to the maximum extent practical. With the implementation of Mitigation Measure HYD-1, impacts on surface water quality as attributable to the project would be reduced to a level less than significant through the inclusion of focused BMPs for the protection of surface water resources. Monitoring and contingency response measures would be included to verify compliance with water quality objectives for all surface waters crossed during construction. In addition, given that site decommissioning would result in similar activities as identified for construction, these impacts could also occur in the future during site restoration activities. This is considered a less than significant impact after mitigation has been incorporated.

Operation

As runoff flows over developed surfaces, water can entrain a variety of potential pollutants including, but not limited to, oil and grease, pesticides, trace metals, and nutrients. These pollutants can become suspended in runoff and carried to receiving waters. These effects are commonly referred to as non-point source water quality impacts.

Long-term operation of the solar facility poses a limited threat to surface water quality after the completion of construction. The project would be subject to the County’s Grading Regulations as specified in Section 91010.02 of the Ordinance Code. However, since the project site is located in unincorporated Imperial County and not subject to a Municipal Separate Storm Sewer System or NPDES General Industrial Permit, there is no regulatory mechanism in place to address post-construction water quality concerns. Based on this consideration, the project has the potential to result in both direct and indirect water quality impacts that could be significant. Although the project site will be surrounded by a levee system designed to divert and retain stormwater, including stormwater from a 100-year storm event (see Appendix I, Drainage Plan), implementation of Mitigation Measure HYD-2 would require the project to incorporate post-construction source control and treatment control BMPs into the project’s final drainage plan. Implementation of the project-specific source control and treatment BMPs into the final drainage plan would result in a decreased potential for storm water pollution.

While source control and treatment control BMPs would be finalized during preparation of the final drainage plan, the following are examples of BMPs that could be utilized to reduce the potential for stormwater pollution.

Source Control BMPs. Source control BMPs (both structural and non-structural) means land use or site planning practices, or structures that aim to prevent urban runoff pollution by reducing the potential for contamination at the source of pollution. Source control BMPs minimize the contact between pollutants and urban runoff. Table 3.10-3 identifies examples of source control BMPs that could be implemented into the proposed project.

Table 3.10-3. Source Control Best Management Practices

Design Concept		Description
1	Design Trash Storage Areas to Reduce Pollution Introduction	Design outdoor trash storage areas so that run-on from adjoining areas cannot enter. Screen or wall trash enclosures to prevent the off-site transport of trash.
2	Activity Restrictions	Restrict activities that have the potential to create adverse impacts on water quality.
3	Non-storm Water Discharges	Provide educational materials on illegal dumping and spill response to employees.
4	Outdoor Loading and Unloading	Handle materials in a manner that prevents any storm water pollution.
5	Spill Prevention, Control, and Cleanup	Require a Spill Prevention, Control, and Countermeasure Plan, and a Hazardous Materials Business Plan in accordance with Federal and State requirements.
6	Education	Provide employees with materials for storm water pollution prevention in the form of brochures and other information in a format approved by the County of Imperial.
7	Integrated Pest Management	Reduce the need for pesticide use onsite by: <ul style="list-style-type: none"> • Keeping pests out of buildings using barriers, screens, and caulking • Eliminating pests through squashing, trapping, washing or pruning • Relying on natural enemies to eat pests • Using pesticides correctly as a last line of defense
8	Vehicle and Equipment Fueling, Cleaning, and Repair	Service all vehicles offsite whenever possible. If servicing is required onsite, it must be conducted in an area isolated from storm drain inlets or drainage ditch inlets. The area must be bermed and precluded from run on. Any spillage must be fully contained and captured and disposed of per County of Imperial Hazardous Waste requirements.



Table 3.10-3. Source Control Best Management Practices

Design Concept		Description
9	Waste Handling and Disposal	Dispose of materials in accordance with Imperial County Hazardous Material Management guidelines. Under no circumstances shall any waste or hazardous materials be stored outside without secondary containment.

Treatment Control BMPs. Treatment control BMPs include both short-term and long-term drainage solutions to ensure the proper sequencing of drainage facilities and treatment of runoff generated from project impervious surfaces prior to off-site discharge.

Mitigation Measure(s)

HYD-1 Prepare SWPPP and Implement BMPs Prior to Construction and Site Restoration. The project applicant or its contractor shall prepare a SWPPP specific to the project and be responsible for securing coverage under SWRCB’s NPDES stormwater permit for general construction activity (Order 2009-0009-DWQ). The SWPPP shall identify specific actions and BMPs relating to the prevention of stormwater pollution from project-related construction sources by identifying a practical sequence for site restoration, BMP implementation, contingency measures, responsible parties, and agency contacts. The SWPPP shall reflect localized surface hydrological conditions and shall be reviewed and approved by the appropriate agency prior to commencement of work and shall be made conditions of the contract with the contractor selected to build and decommission the project. The SWPPP shall incorporate control measures in the following categories:

- Soil stabilization and erosion control practices (e.g., hydroseeding, erosion control blankets, mulching)
- Sediment control practices (e.g., temporary sediment basins, fiber rolls)
- Temporary and post-construction on- and off-site runoff controls
- Special considerations and BMPs for water crossings and drainages
- Monitoring protocols for discharge(s) and receiving waters, with emphasis place on the following water quality objectives: dissolved oxygen, floating material, oil and grease, potential of hydrogen (pH), and turbidity
- Waste management, handling, and disposal control practices
- Corrective action and spill contingency measures
- Agency and responsible party contact information
- Training procedures that shall be used to ensure that workers are aware of permit requirements and proper installation methods for BMPs specified in the SWPPP

The SWPPP shall be prepared by a Qualified SWPPP Practitioner and/or Qualified SWPPP Developer with BMPs selected to achieve maximum pollutant removal and that represent the best available technology that is economically achievable. Emphasis for BMPs shall be placed on controlling discharges of oxygen-depleting

substances, floating material, oil and grease, acidic or caustic substances or compounds, and turbidity. BMPs for soil stabilization and erosion control practices and sediment control practices will also be required. Performance and effectiveness of these BMPs shall be determined either by visual means where applicable (i.e., observation of above-normal sediment release), or by actual water sampling in cases where verification of contaminant reduction or elimination, (inadvertent petroleum release) is required to determine adequacy of the measure.

HYD-2 Incorporate Post-Construction Runoff, Source Control, and Treatment Control BMPs into Final Project Drainage Plan. The project's Final Drainage Plan shall adhere to the County's Engineering Guidelines Manual, IID "Draft" Hydrology Manual, or other recognized source with approval by the County Engineer to control and manage the on- and off-site discharge of stormwater to existing drainage systems. The Final Drainage Plan shall provide both short- and long-term drainage solutions to ensure the proper sequencing of drainage facilities, and shall include source control and treatment BMPs to adequately treat collected runoff prior to discharge, as necessary.

Significance after Mitigation

With the implementation of Mitigation Measure HYD-1, impacts on hydrology and surface water quality as attributable to the proposed project would be reduced to a level less than significant through the inclusion of focused BMPs for the protection of surface water resources. Monitoring and contingency response measures would be included to verify compliance with water quality objectives for all surface waters crossed during construction.

With the implementation of Mitigation Measure HYD-2, potential hydrology and water quality impacts resulting from post-construction discharges during operation for the project would be reduced to a less than significant level. Implementation of Mitigation Measure HYD-2 would require the project to incorporate post-construction BMPs into the project's final drainage plan. The incorporation of source control and treatment BMPs into the final drainage plan would result in a decreased potential for storm water pollution.

Impact 3.10-2 *Would the project substantially decrease groundwater supplies or interfere substantially with groundwater recharge such that the project may impede sustainable groundwater management of the basin?*

Groundwater recharge in the area will not be significantly affected because the majority of the project site will feature a pervious landscape in both the existing and proposed conditions. Any runoff from solar panel washing would evaporate or percolate through the ground, as a majority of the surfaces in the solar field would remain pervious. Groundwater at/near the project site is not used for beneficial uses, such as municipal, domestic, or industrial supply. Construction and operational water needs would be provided by the All-American Canal in conformance with IID construction water acquisition requirements. Therefore, the proposed project would not substantially decrease groundwater supplies or interfere substantially with groundwater recharge such that the proposed project may impede sustainable groundwater management of the basin. As a result, no significant impacts on groundwater levels are expected.

Mitigation Measure(s)

No mitigation measures are required.

Impact ***Would the project substantially alter the existing drainage pattern of the site***
3.10-3 ***or area, including through the alteration of the course of a stream or river or***
 through the addition of impervious surfaces, in a manner which would:

Result in substantial erosion or siltation on- or off-site?

Construction

Project construction activities, specifically grading and excavation, have the potential to temporarily alter the existing drainage pattern of the site such that soil erosion occurs. However, to the extent feasible, site preparation would be planned and designed to minimize the amount of earth movement. Compaction of the soil to support building and traffic loads as well as the PV module supports may be required and is dependent on final engineering design. During construction, erosion would be controlled in accordance with County standards which include preparation, review and approval of a grading plan by the County Engineer; implementation of a Dust Control Plan (Rule 801); and compliance with the NPDES General Construction Permit. Additionally, with implementation of Mitigation Measure HWQ-1, which requires the preparation of a project-specific SWPPP and construction BMPs, project construction would not substantially alter the existing drainage pattern of the site or area, including through the alteration of the course of a stream or river or through the addition of impervious surfaces, in a manner which would result in substantial on- or off-site erosion or siltation. This is considered a less than significant impact after mitigation has been incorporated.

Operation

Daily operations and routine maintenance (such as occasional PV panel washing) are not anticipated to increase erosion. Under existing conditions, runoff from adjacent agricultural land collects and is concentrated in the project site. Runoff within the project site generally flows south from the direction of the All-American Canal, toward the U.S.-Mexico border, and eventually drains into a playa at the south end of the site. While implementation of the project would include a new levee drainage system, the drainage system would be designed to continue to retain stormwater onsite. Additionally, during operational activities, soil erosion and sedimentation would be controlled in accordance with the NPDES General Construction Permit and project-specific SWPPP. The project site would remain largely impervious over the operational life of the project. The proposed project would result in less than significant impacts associated with the alteration of drainage patterns resulting in substantial erosion or siltation on- or off-site. This is considered a less than significant impact.

Mitigation Measure(s)

No additional mitigation measures beyond Mitigation Measure HYD-1 are required.

Significance after Mitigation

With the implementation of Mitigation Measures HYD-1, the potential hydrology and water quality impacts resulting from increased erosion during construction of the proposed project would be reduced to a level less than significant.

Impact ***Would the project substantially alter the existing drainage pattern of the site or area, including through the alteration of the course of a stream or river or through the addition of impervious surfaces, in a manner which would:***
3.10-4

Substantially increase the rate or amount of surface runoff in a manner which would result in flooding on- or offsite?

Construction

Project construction activities, specifically grading and excavation, have the potential to temporarily alter the existing drainage pattern of the site such that surface runoff increases in a manner which results in flooding on- or off-site. However, to the extent feasible, site preparation would be planned and designed to minimize the amount of earth movement. Compaction of the soil to support building and traffic loads as well as the PV module supports may be required and is dependent on final engineering design. During construction, erosion would be controlled in accordance with County standards which include preparation, review and approval of a grading plan by the County Engineer; implementation of a Dust Control Plan (Rule 801); and compliance with the NPDES General Construction Permit. Additionally, with implementation of Mitigation Measure HWQ-1, which requires the preparation of a project-specific SWPPP and construction BMPs, project construction would not substantially alter the existing drainage pattern of the site or area, including through the alteration of the course of a stream or river or through the addition of impervious surfaces, in a manner which would result in flooding on- or off-site. This is considered a less than significant impact after mitigation has been incorporated.

Operation

Existing drainage patterns would not be substantially altered during operation of the proposed project. Under existing conditions, runoff from adjacent agricultural land collects and is concentrated in the project site. Runoff within the project site generally flows south from the direction of the All-American Canal, toward the U.S.-Mexico border, and eventually drains into a playa at the south end of the site. While implementation of the project would include a new levee drainage system, the drainage system would be designed to continue to retain stormwater onsite. Additionally, the project will be designed to meet County of Imperial storage requirements for storm water runoff, which will result in an impoundment of runoff in excess of the anticipated volume of runoff to be generated by the 100-year storm event. Therefore, the proposed project would result in no significant impacts associated with the alteration of drainage patterns resulting in on- or off-site flooding. This is considered a less than significant impact after mitigation has been incorporated.

Mitigation Measure(s)

No additional mitigation measures beyond Mitigation Measure HYD-1 are required.

Significance after Mitigation

With the implementation of Mitigation Measures HYD-1 and HYD-2, the potential hydrology and water quality impacts resulting from increased surface runoff and associated flooding during construction and operation of the proposed project would be reduced to a level less than significant.

Impact ***Would the project substantially alter the existing drainage pattern of the site***
3.10-5 ***or area, including through the alteration of the course of a stream or river or***
 through the addition of impervious surfaces, in a manner which would:

Create or contribute runoff water which would exceed the capacity of existing or planned stormwater drainage systems or provide substantial additional sources of polluted runoff?

Construction

Project construction activities, specifically grading and excavation, have the potential to temporarily alter the existing drainage pattern of the site such that the capacity of existing or planned stormwater drainage systems is exceeded or substantial additional sources of polluted runoff are added to the stormwater drainage system. However, to the extent feasible, site preparation would be planned and designed to minimize the amount of earth movement. Compaction of the soil to support building and traffic loads as well as the PV module supports may be required and is dependent on final engineering design. During construction, erosion would be controlled in accordance with County standards which include preparation, review and approval of a grading plan by the County Engineer; implementation of a Dust Control Plan (Rule 801); and compliance with the NPDES General Construction Permit. Additionally, with implementation of Mitigation Measure HWQ-1, which requires the preparation of a project-specific SWPPP and construction BMPs, project construction would not substantially alter the existing drainage pattern of the site or area, including through the alteration of the course of a stream or river or through the addition of impervious surfaces, in a manner which would create or contribute runoff water which would exceed the capacity of existing or planned stormwater drainage systems or provide substantial additional sources of polluted runoff. This is considered a less than significant impact after mitigation has been incorporated.

Operation

The proposed project is not anticipated to generate a significant increase in the amount of runoff water from water use involving solar panel washing. Water will continue to percolate through the ground, as a majority of the surfaces on the project site would remain pervious. Existing drainage patterns would not be substantially altered because of the proposed project. Under existing conditions, runoff from adjacent agricultural land collects and is concentrated in the project site. Runoff within the project site generally flows south from the direction of the All-American Canal, toward the U.S.-Mexico border, and eventually drains into a playa at the south end of the site. While implementation of the project would include a new levee drainage system, the drainage system would be designed to continue to retain stormwater onsite. Additionally, with the implementation of Mitigation Measure HYD-2, potential water quality impacts resulting from post-construction discharges during operation of the project would be reduced to a less than significant level. Implementation of Mitigation Measure HYD-2 would require the project to incorporate post-construction BMPs into the project's final drainage plan. The incorporation of source control and treatment BMPs into the final drainage plan would result in a decreased potential for stormwater pollution. The proposed project would not create or contribute runoff water which would exceed the capacity of existing or planned stormwater drainage systems or provide substantial additional sources of polluted runoff. This is considered a less than significant impact after mitigation has been incorporated.

Mitigation Measure(s)

No additional mitigation measures beyond Mitigation Measure HYD-1 and HYD-2 are required.

Significance after Mitigation

With the implementation of Mitigation Measures HYD-1 and HYD-2, the potential hydrology and water quality impacts resulting from increased surface runoff and associated increases in polluted runoff entering the storm drain system during construction and operation of the proposed project would be reduced to a level less than significant.

Impact 3.10-6 *Would the project substantially alter the existing drainage pattern of the site or area, including through the alteration of the course of a stream or river or through the addition of impervious surfaces, in a manner which would:*

Impede or redirect flood flows?

According to the FEMA Flood Insurance Rate Map (Panel 06025C2125C) (FEMA 2008), the project site is within Zone X, which is an area determined to be outside of the 0.2 percent annual chance of a flood. Additionally, the project's drainage plan has been designed to meet County of Imperial storage requirements for storm water runoff, which will result in an impoundment of runoff in excess of the anticipated volume of runoff to be generated by the 100-year storm event. Therefore, the proposed project would not substantially alter the existing drainage pattern of the site or area, including through the alteration of the course of a stream or river or through the addition of impervious surfaces, in a manner which would impede or redirect flood flows, and no impact would occur.

Mitigation Measure(s)

No mitigation measures are required.

Impact 3.10-7 *In flood hazard, tsunami, or seiche zones, would the project risk release of pollutants due to project inundation?*

The project site is within Zone X, which is an area determined to be outside of the 0.2 percent annual chance of a flood. The project site is not located near any large bodies of water. The Salton Sea is located approximately 38 miles northwest of the project site. Because of the distance, the Salton Sea does not pose a particularly significant danger of inundation from seiche or tsunami as related to the project site. Furthermore, the project site is over 100 miles inland from the Pacific Ocean. In addition, the project site is relatively flat. Therefore, there is no potential for the project site to be inundated by seiches or tsunamis.

Mitigation Measure(s)

No mitigation measures are required.

Impact 3.10-8 *Would the project conflict with or obstruct implementation of a water quality control plan or sustainable groundwater management plan?*

As described under Impact 3.10-1 above, with the implementation of Mitigation Measure HYD-1, impacts on surface water quality as attributable to the proposed project would be reduced to a level less than significant through the inclusion of focused BMPs for the protection of surface water

resources. Implementation of Mitigation Measure HYD-2 would require the project to incorporate post-construction BMPs into the project's final drainage plan. The use of source control, site design, and treatment BMPs would result in a decrease potential for storm water pollution. Therefore, the proposed project would not pose a significant threat to local surface water features or shallow groundwater resources. Implementation of Mitigation Measures HYD-1 and HYD-2 would reduce impacts to a level less than significant.

Mitigation Measure(s)

No additional mitigation measures beyond Mitigation Measures HYD-1 and HYD-2 are required.

Significance after Mitigation

With the implementation of Mitigation Measures HYD-1 and HYD-2, the potential hydrology and water quality impacts resulting from conflicts with a water quality control plan or groundwater management plan during construction and operation of the proposed project would be reduced to a level less than significant.

3.10.4 Decommissioning/Restoration and Residual Impacts

Decommissioning/Restoration

Decommissioning and restoration activities would result in similar impacts on hydrology and water quality as would occur during construction of the proposed project. The primary water quality issue associated with decommissioning/restoration would be potential impacts on surface water quality, as the decommissioning activities would be similar to construction activities and would be considered a significant impact. However, during decommissioning, soil erosion would be controlled in accordance with NPDES General Construction Permit(s) and project-specific SWPPP. Compliance with requirements and best available control technologies in place at the time of decommissioning are anticipated to be similar to, or more stringent than, those currently required. Compliance with all applicable water quality regulations would reduce the project's impacts during decommissioning to a level less than significant. Impacts on other water resource issues, including alteration of drainage patterns, contributing to off-site flooding, impacts on groundwater recharge and supply, would be less than significant. There would be no impact associated with inundation from flooding, tsunamis, or seiche zones.

Residual

With implementation of the mitigation measures listed above, implementation of the proposed project would not result in any residual significant impacts related to increased risk of flooding from stormwater runoff, from water quality effects from long-term urban runoff, or from short-term alteration of drainages and associated surface water quality and sedimentation. With the implementation of the required mitigation measures during construction and decommissioning of the project, water quality impacts would be minimized to a level less than significant. Based on these circumstances, the proposed project would not result in any residential significant and unmitigable adverse impacts on surface water hydrology and water quality.

This page is intentionally blank.

3.11 Land Use Planning

This section provides information regarding current land use, land use designations, and land use policies within, and in the vicinity of, the project site. Section 15125(d) of the CEQA Guidelines states that “[t]he EIR shall discuss any inconsistencies between the project and applicable general plans and regional plans.” This section fulfills this requirement for the project. In this context, this section reviews the land use assumptions, designations, and policies of the County General Plan and other applicable federal, state, and local requirements, which governs land use within the project area and evaluates the project’s potential to conflict and/or adherence with policies adopted for the purpose of avoiding or mitigating significant environmental effects. Where appropriate, mitigation is applied and the resulting level of impact identified.

3.11.1 Existing Conditions

The project site is located within an unincorporated area of Imperial County, approximately 10 miles east of the City of Calexico. The 450-acre project site is located on two contiguous privately-owned parcels (APNs 059-300-015 and 059-300-017). The irregular shaped project site is bound by undeveloped land, portions of which have been disturbed associated with previous agricultural-related activities to the west and east, the All-American Canal running southwest on the northern border of the project site, and the U.S./Mexico international border to the south. The project site is currently characterized by flat and undeveloped land, portions of which have been disturbed associated with previous agricultural-related activities. The existing IID 92 kV “P” Line is located immediately north of the All-American Canal.

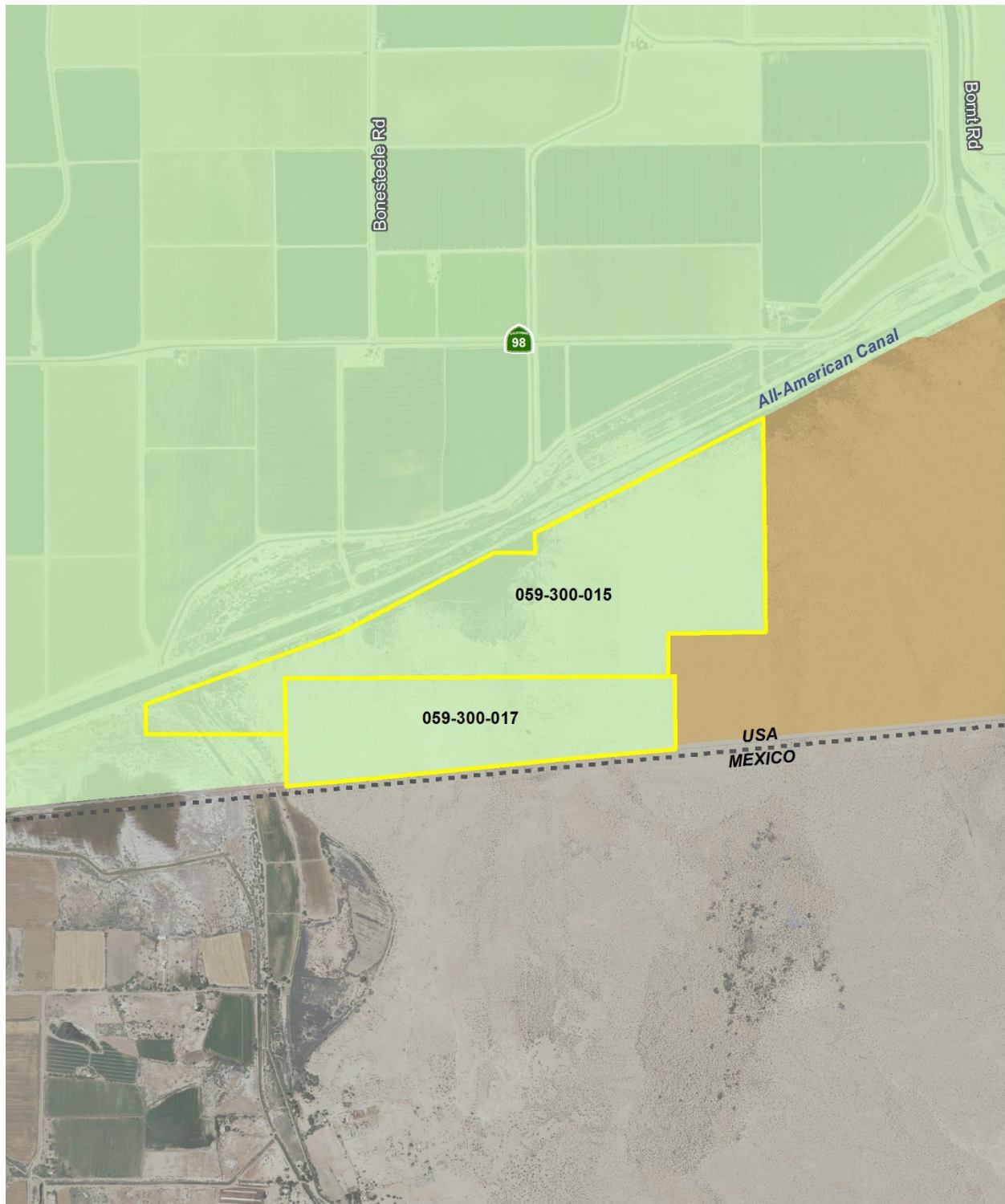
As shown on Figure 3.11-1, the project site is designated as Agriculture under the County’s General Plan. As shown on Figure 3.11-2, the project site is currently zoned Heavy Agriculture with a RE Zone Overlay (A-3-RE). Land uses surrounding the project site are designated by the General Plan as Agriculture to the north and west, and Recreation to the east.

The County adopted the RE and Transmission Element, which includes a RE Zone (RE Overlay Map). The RE Overlay Zone is concentrated in areas determined to be the most suitable for the development of RE facilities while minimizing the impact to other established uses. As shown on Figure 3.11-2, the entire project site is located within the RE Overlay Zone.


The project site is located in a sparsely populated portion of Imperial County. There are no established residential communities located within or in the vicinity of the project site. The nearest established residential community is in Calexico.

The nearest airports to the project site are the Calexico International Airport located approximately 10 miles west of the project site and the Holtville Airport located approximately 10 miles north of the project site.

Figure 3.11-1. General Plan Land Use Designations



Legend

 Project Site (Assessor Parcel No. 059-300-015 and 059-300-017)

General Plan Land Use

-  Agriculture
-  Recreation

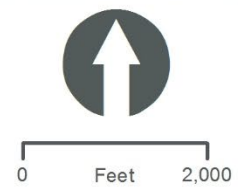
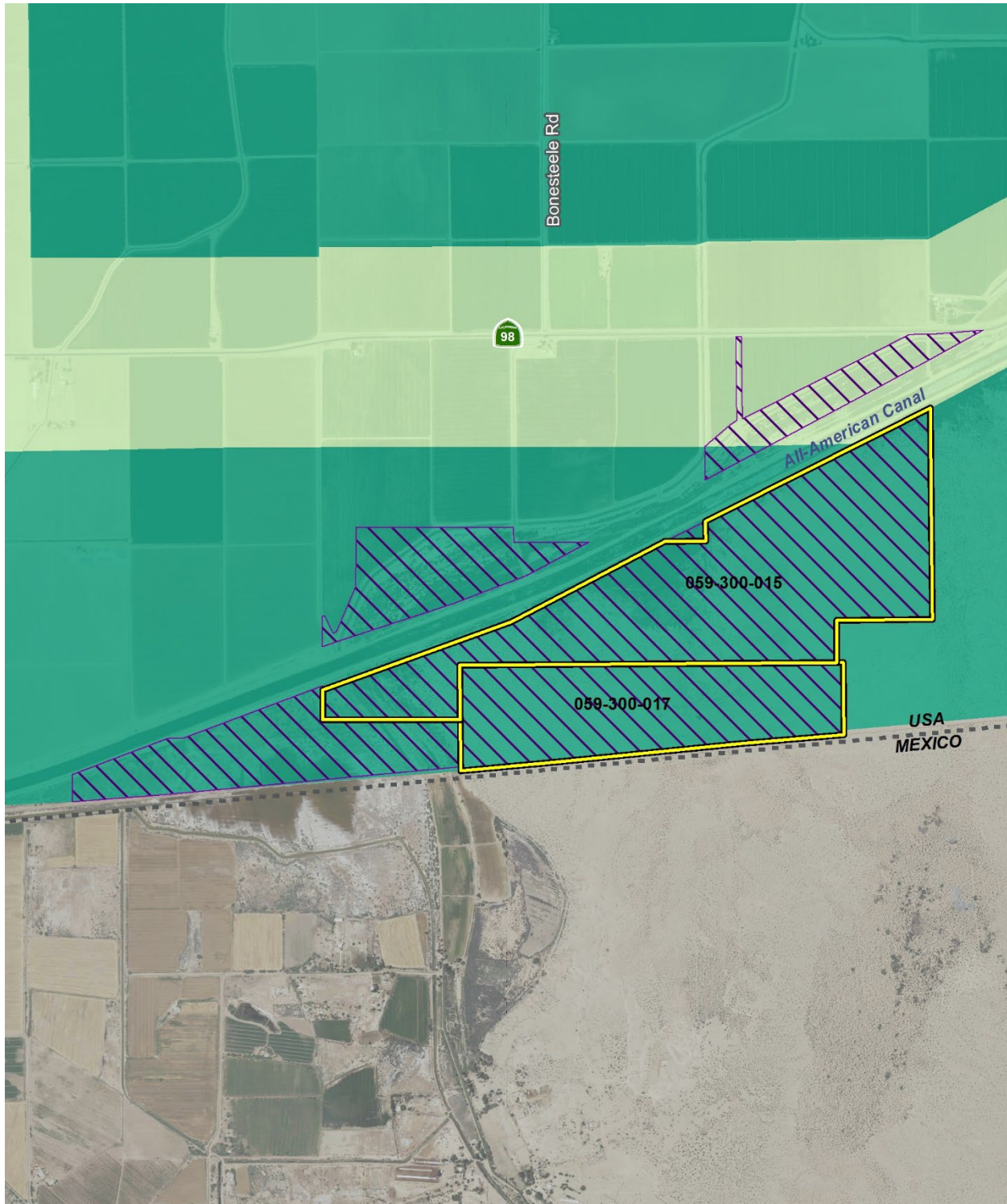


Figure 3.11-2. Zoning Designations



Legend

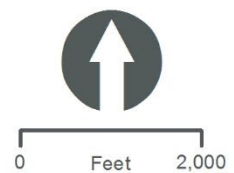
Project Site (Assessor Parcel No. 059-300-015 and 059-300-017)

Renewable Energy Overlay

Zoning

A-2 - General Agricultural Zone

A-3 - Heavy Agriculture



3.11.2 Regulatory Setting

This section identifies and summarizes laws, policies, and regulations that are applicable to the project.

State

State Planning and Zoning Laws

California Government Code Section 65300 et seq. establishes the obligation of cities and counties to adopt and implement general plans. The general plan is a comprehensive, long-term, and general document that describes plans for the physical development of a city or county and of any land outside its boundaries that, in the city's or county's judgment, bears relation to its planning.

The general plan addresses a broad range of topics, including, at a minimum, land use, circulation, housing, conservation, open space, noise, and safety. In addressing these topics, the general plan identifies the goals, objectives, policies, principles, standards, and plan proposals that support the city's or county's vision for the area. The general plan is a long-range document that typically addresses the physical character of an area over a 20-year period or more.

The State Zoning Law (California Government Code Section 65800 et seq.) establishes that zoning ordinances, which are laws that define allowable land uses within a specific zone district, are required to be consistent with the general plan and any applicable specific plans.

Regional

Southern California Association of Governments – 2020-2045 Regional Transportation Plan/Sustainable Communities Strategy (Connect SoCal)

SCAG is the designated metropolitan planning organization for Los Angeles, Ventura, Orange, San Bernardino, Riverside, and Imperial Counties. CEQA requires that regional agencies like SCAG review projects and plans throughout its jurisdiction. SCAG, as the region's "Clearinghouse," collects information on projects of varying size and scope to provide a central point to monitor regional activity. SCAG has the responsibility of reviewing dozens of projects, plans, and programs every month. Projects and plans that are regionally significant must demonstrate to SCAG their consistency with a range of adopted regional plans and policies.

On September 3, 2020, SCAG adopted the 2020-2045 RTP/SCS (Connect SoCal). The 2020-2045 RTP/SCS (Connect SoCal) includes a strong commitment to reduce emissions from transportation sources to comply with Senate Bill 375, improve public health, and meet the NAAQS as set forth by the federal CAA. The following goals from the 2020-2045 RTP/SCS (Connect SoCal) are considered applicable to the proposed project:

- Goal 5: Reduce GHG emissions and improve air quality
- Goal 10: Promote conservation of natural and agricultural lands and restoration of habitats

Local

County of Imperial General Plan

The purpose of the County's General Plan (as amended through 2008) is to direct growth, particularly urban development, to areas where public infrastructure exists or can be provided, where public health and safety hazards are limited, and where impacts to the County's abundant natural, cultural, and



economic resources can be avoided. The following 10 elements comprise the County’s General Plan: Land Use; Housing; Circulation and Scenic Highways; Noise; Seismic and Public Safety; Conservation and Open Space; Agricultural; RE and Transmission Element; Water; and Parks and Recreation. Together, these elements satisfy the seven mandatory general plan elements as established in the California Government Code. Goals, objectives, and implementing policies and actions programs have been established for each of the elements.

Imperial County received funding from the California Energy Commission RE and Conservation Planning Grant to amend and update the County’s General Plan in order to facilitate future development of RE projects. The Geothermal/Alternative Energy and Transmission Element was last updated in 2006. Since then there have been numerous renewable projects proposed, approved, and constructed within Imperial County as a result of California’s move to reduce GHG emissions, develop alternative fuel sources and implement its Renewable Portfolio Standard. The County prepared an update to the Geothermal/Alternative Energy and Transmission Element of its General Plan, called the RE and Transmission Element. This Element is designed to provide guidance and approaches with respect to the future siting of RE projects and electrical transmission lines in the County. The County adopted this element in 2016, which has been amended several times to incorporate additional overlay zones.

The RE and Transmission Element includes a RE Zone (RE Overlay Map). The County Land Use Ordinance, Division 17, includes the RE Overlay Zone, which authorizes the development and operation of RE projects, with an approved CUP. The RE Overlay Zone is concentrated in areas determined to be the most suitable for the development of RE facilities while minimizing the impact to other established uses. As shown on Figure 3.11-2, the entire project site is located within the RE Overlay Zone.

An analysis of the project’s consistency with the General Plan goals and objectives relevant to the project is provided in Table 3.11-1. While this EIR analyzes the project’s consistency with the General Plan pursuant to CEQA Guidelines Section 15125(d), the Imperial County Planning Commission and Board of Supervisors retain final authority for the determination of the project’s consistency with the General Plan.

Table 3.11-1. Project Consistency with Applicable General Plan Policies

Applicable Policies	Consistency Determination	Analysis
Land Use Element		
Public Facilities. Objective 8.7: Ensure the development, improvement, timing, and location of community sewer, water, and drainage facilities will meet the needs of existing communities and new developing areas.	Consistent	The proposed project includes the necessary supporting infrastructure and would not require new community-based infrastructure. The proposed project would be required to construct supporting drainage infrastructure on-site consistent with County requirements and mitigation measures prescribed in Section 3.10 Hydrology/Water Quality of the EIR. Once the proposed project is operational, a limited amount of water would be required for solar panel washing and fire protection. The proposed project would not require an operations and maintenance building. Therefore, no septic system would be required for the proposed project.

Table 3.11-1. Project Consistency with Applicable General Plan Policies

Applicable Policies	Consistency Determination	Analysis
Public Facilities. Objective 8.8: Ensure that the siting of future facilities for the transmission of electricity, gas, and telecommunications is compatible with the environment and County regulation.	Consistent	The County Land Use Ordinance, Division 17, includes the RE Overlay Zone, which authorizes the development and operation of RE projects with an approved CUP. The RE Overlay Zone is concentrated in areas determined to be the most suitable for the development of RE facilities while minimizing the impact to other established uses. As shown on Figure 3.11-2, the project site is located within the RE Overlay Zone. Therefore, the proposed project would be sited in a suitable location for the transmission of electricity.
Public Facilities. Objective 8.9: Require necessary public utility rights-of-way when appropriate.	Consistent	The proposed project would include the dedication of ROW, if necessary, to facilitate the placement of electrical distribution and transmission infrastructure.
Protection of Environmental Resources. Objective 9.6: Incorporate the strategies of the Imperial County AQAP in land use planning decisions and as amended.	Consistent	Dust suppression will be implemented in accordance with a dust control plan approved by the ICAPCD. Section 3.4, Air Quality, discusses the project's consistency with the AQAP in more detail.
<i>Circulation and Scenic Highways Element</i>		
Safe, Convenient, and Efficient Transportation System. Objective 1.1: Maintain and improve the existing road and highway network, while providing for future expansion and improvement based on travel demand and the development of alternative travel modes.	Consistent	The proposed project would include limited operational vehicle trips and would not be expected to reduce the current LOS at affected intersections, roadway segments, and highways. The proposed project does not propose residential or commercial development and therefore would not require new forms of alternative transportation to minimize impacts to existing roadways.
Safe, Convenient, and Efficient Transportation System. Objective 1.2: Require a traffic analysis for any new development which may have a significant impact on County roads.	Consistent	As described in Section 3.13, Transportation, a traffic study was prepared for the project and determined that the proposed project would have a less than significant impact on the circulation network. Once construction is completed, the project would be remotely operated, controlled and monitored and with no requirement for daily on-site employees. The project would include limited operational vehicle trips and would not reduce the current level of service at affected intersections, roadway segments, and highways.



Table 3.11-1. Project Consistency with Applicable General Plan Policies

Applicable Policies	Consistency Determination	Analysis
Noise Element		
Noise Environment. Objective 1.3: Control noise levels at the source where feasible.	Consistent	As discussed in Section 3.12, Noise and Vibration, no individual or cumulative pieces of construction equipment would exceed the 75 dBA Imperial County construction noise standard during any phase of construction at the nearest noise-sensitive receptor. Project operational noise would not exceed County daytime or nighttime standards.
Project/Land Use Planning. Goal 2: Review Proposed Actions for noise impacts and require design which will provide acceptable indoor and outdoor noise environments.	Consistent	The project would be required to comply with the County's noise standards during both construction and operation. As discussed in Section 3.12, Noise and Vibration, no individual or cumulative pieces of construction equipment would exceed the 75 dBA Imperial County construction noise standard during any phase of construction at the nearest noise-sensitive receptor. Project operational noise would not exceed County daytime or nighttime standards.
Conservation and Open Space Element		
Conservation of Environmental Resources for Future Generations Goal 1: Environmental resources shall be conserved for future generations by minimizing environmental impacts in all land use decisions and educating the public on their value.	Consistent	<p>The project site would be converted from undeveloped land to a solar energy facility. The proposed project is a response to the state's need for renewable energy to meet its Renewable Portfolio Standard, and while it would increase the availability of renewable energy, it would also replace existing sources of non-renewable energy.</p> <p>The power generated by the proposed project would be added to the state's electricity grid with the intent that it would displace fossil fueled power plants and their associated environmental impacts (i.e., air quality and GHG emissions). The proposed project would ensure future generations have access to a broad array of renewable energy sources, providing the public with alternative choices to fossil fuels.</p>
Conservation of Biological Resources. Goal 2: The County will integrate programmatic strategies for the conservation of critical habitats to manage their integrity, function, productivity, and long-term viability.	Consistent	A biological resources survey was conducted for the project site. As discussed in Section 3.5, Biological Resources, there are potentially significant biological resources located within the project site. However, with the implementation of Mitigation Measures BIO-1 through BIO-7 these impacts would be reduced to a level less than significant. The project site is not designated or otherwise identified as critical habitat for any species.

Table 3.11-1. Project Consistency with Applicable General Plan Policies

Applicable Policies	Consistency Determination	Analysis
<p>Preservation of Cultural Resources. Objective 3.1: Protect and preserve sites of archaeological, ecological, historical, and scientific value, and/or cultural significance.</p>	<p>Consistent</p>	<p>A cultural resources report was prepared for the project site. As discussed in Section 3.6, Cultural Resources, the proposed project has the potential to impact historical resources, and encounter undocumented archaeological resources and human remains. Mitigation Measures CR-1 and CR-4 have been identified to reduce potential impacts to a level less than significant.</p>
<p>Conservation of Water Resources. Objective 6.1: Ensure the use and protection of all the rivers, waterways, and groundwater sources in the County for use by future generations.</p>	<p>Consistent</p>	<p>As discussed in Section 3.10, Hydrology/Water Quality, the project will prepare a site-specific drainage plan and water quality management plan to minimize adverse effects to local water resources; as well as coordinate with the IID for water consumption during construction and operation of the project.</p>
<p>Conservation of Energy Sources. Objective 6.2: Encourage the utilization of alternative passive and renewable energy resources.</p>	<p>Consistent</p>	<p>The proposed project entails the construction and operation of a solar energy facility, which is considered an alternative source of energy.</p>
<p>Conservation of Energy Sources. Objective 6.6: Encourage compatibility with National and State energy goals and city and community general plans.</p>	<p>Consistent</p>	<p>The proposed project is consistent with California Public Utilities Code § 399.11 et seq., “Increasing the Diversity, Reliability, Public Health and Environmental Benefits of the Energy Mix.” California’s electric utility companies are required to procure 50 percent of their electricity from eligible renewable energy resources by 2030. Additionally, the proposed project would contribute toward the state’s need for RE to meet the goals of its Renewable Portfolio Standard.</p>
<p>Protection of Air Quality and Addressing Climate Change. Goal 7: The County shall actively seek to improve the quality of air in the region.</p>	<p>Consistent</p>	<p>The proposed project would be required to comply with all applicable ICAPCD rules and requirements during construction and operation to reduce air emissions. Overall, the proposed project would improve air quality and reduce GHG emissions by reducing the amount of emissions that would be generated in association with electricity production from a fossil fuel burning facility. Therefore, the proposed project is consistent with this goal.</p>
<p>Protection of Air Quality and Addressing Climate Change. Objective 7.1: Ensure that all project and facilities comply with current Federal, State and local requirements for attainment of air quality objectives.</p>	<p>Consistent</p>	<p>The proposed project would comply with current federal and State requirements for attainment for air quality objectives through conformance with all applicable ICAPCD rules and requirements to reduce fugitive dust and emissions. Further, the proposed project would comply with the ICAPCD Air Quality CEQA Handbook’s Mandatory Standard, Discretionary and Enhanced Air Quality Measures (Mitigation Measure AQ-1). Therefore, the proposed project is consistent with this objective.</p>



Table 3.11-1. Project Consistency with Applicable General Plan Policies

Applicable Policies	Consistency Determination	Analysis
Protection of Air Quality and Addressing Climate Change. Objective 7.2: Develop management strategies to mitigate fugitive dust. Cooperate with all federal and state agencies in the effort to attain air quality objectives.	Consistent	The Applicant would cooperate with all federal and State agencies in the effort to attain air quality objectives through compliance with the ICAPCD Air Quality CEQA Handbook’s Mandatory Standard, Discretionary and Enhanced Air Quality Measures (Mitigation Measure AQ-1). Therefore, the proposed project is consistent with this objective.
Protection of Open Space and Recreational Opportunities. Objective 8.2: Focus all new renewable energy development within adopted Renewable Energy Overlay Zones.	Consistent	As shown on Figure 3.11-2, the project site is located entirely within the RE Overlay Zone.
<i>RE and Transmission Element</i>		
Objective 1.4: Analyze potential impacts on agricultural, natural, and cultural resources, as appropriate.	Consistent	This EIR has been prepared to meet the requirements of CEQA for purposes of evaluating the potential environmental impacts associated with the proposed project, which includes analysis on applicable environmental topics that analyze impacts on agricultural, natural, and cultural resources.
Objective 1.5: Require appropriate mitigation and monitoring for environmental issues associated with developing RE facilities.	Consistent	A biological resources report has been prepared for the project, which is summarized in Section 3.5, Biological Resources, along with potential impacts attributable to the proposed project. With incorporation of Mitigation Measures BIO-1 through BIO-7 identified in Section 3.5, Biological Resources, less than significant impacts would result.
Objective 1.6: Encourage the efficient use of water resources required in the operation of renewable energy generation facilities.	Consistent	As previously mentioned, water consumption during construction would be used primarily for dust control, and obtained from local IID irrigation canals or laterals in conformance with IID construction water acquisition requirements. The project applicant will also coordinate with IID to purchase water needed for maintenance activities (i.e., PV module washing) to ensure efficient use of water resources.
Objective 1.7: Assure that development of RE facilities and transmission lines comply with ICAPCD’s regulations and mitigation measures.	Consistent	Dust suppression will be implemented including the use of water and soil binders during construction. Section 3.4, Air Quality, discusses the project’s compliance with ICAPCD’s regulations in more detail.

Table 3.11-1. Project Consistency with Applicable General Plan Policies

Applicable Policies	Consistency Determination	Analysis
<p>Objective 2.1: To the extent practicable, maximize utilization of IID’s transmission capacity in existing easements or rights-of-way. Encourage the location of all major transmission lines within designated corridors easements, and rights-of-way.</p>	<p>Consistent</p>	<p>The proposed project involves the construction and operation of new RE infrastructure that would interconnect with existing IID transmission infrastructure thereby maximizing the use of existing facilities located within existing easements and/or ROW. As discussed in Chapter 2, Project Description, the power produced by the proposed project would be conveyed to the local power grid via an on-site 92 kV substation, which will be tied directly to IID’s existing 92 kV “P” transmission line.</p>
<p><i>Seismic and Public Safety Element</i></p>		
<p>Land Use Planning and Public Safety. Goal 1: Include public health and safety considerations in land use planning.</p>	<p>Consistent</p>	<p>Division 5 of the County Land Use Ordinance has established procedures and standards for development within earthquake fault zones. Per County regulations, construction of buildings intended for human occupancy which are located across the trace of an active fault are prohibited. An exception exists when such buildings located near the fault or within a designated Special Studies Zone are demonstrated through a geotechnical analysis and report not to expose a person to undue hazard created by the construction.</p> <p>Since the project site is located in a seismically active area, the project is required to be designed in accordance with the CBC for near source factors derived from a design basis earthquake based on a peak ground acceleration of 0.50 gravity. It should be noted that, the project would be remotely operated and would not require any habitable structures on site. In considering these factors in conjunction with mitigation requirements outlined in the impact analysis, the risks associated with seismic hazards would be minimized.</p> <p>A preliminary geotechnical report has been prepared for the proposed project. The preliminary geotechnical report has been referenced in this environmental document. Additionally, a design-level geotechnical investigation would be conducted to evaluate the potential for site specific hazards associated with seismic activity.</p>
<p>Land Use Planning and Public Safety. Objective 1.1: Ensure that data on geological hazards is incorporated into the land use review process, and future development process.</p>		
<p>Land Use Planning and Public Safety. Objective 1.3: Regulate development adjacent to or near all mineral deposits and geothermal operations.</p>		
<p>Land Use Planning and Public Safety. Objective 1.4: Require, where possessing the authority, that avoidable seismic risks be avoided; and that measures, commensurate with risks, be taken to reduce injury, loss of life, destruction of property, and disruption of service.</p>		
<p>Land Use Planning and Public Safety. Objective 1.7: Require developers to provide information related to geologic and seismic hazards when siting a proposed project.</p>		
<p>Emergency Preparedness. Goal 2: Minimize potential hazards to public health, safety, and welfare and prevent the loss of life and damage to health and property resulting from both natural and human-related phenomena.</p>		
<p>Emergency Preparedness. Objective 2.2: Reduce risk and damage due to seismic hazards by appropriate regulation.</p>		



Table 3.11-1. Project Consistency with Applicable General Plan Policies

Applicable Policies	Consistency Determination	Analysis
Emergency Preparedness. Objective 2.5: Minimize injury, loss of life, and damage to property by implementing all state codes where applicable.		
Emergency Preparedness. Objective 2.8: Prevent and reduce death, injuries, property damage, and economic and social dislocation resulting from natural hazards including flooding, land subsidence, earthquakes, other geologic phenomena, levee or dam failure, urban and wildland fires and building collapse by appropriate planning and emergency measures.		
Water Element		
Protection of Water Resources from Hazardous Materials. Program: The County of Imperial shall make every reasonable effort to limit or preclude the contamination or degradation of all groundwater and surface water resources in the County.	Consistent	Mitigation measures will require that the applicant of the proposed project prepare a site-specific drainage plan and water quality management plan to minimize adverse effects to local water resources.
Protection of Water Resources from Hazardous Materials. Program: All development proposals brought before the County of Imperial shall be reviewed for potential adverse effects on water quality and quantity, and shall be required to implement appropriate mitigation measures for any significant impacts.	Consistent	See previous response for Water Element above.
Housing Element		
Not Applicable. The proposed project is a solar energy project and does not include the development of housing.		

Source: Imperial County General Plan, as amended

Notes:

AQAP=air quality attainment plan; CBC=California Building Code; CUP=conditional use permit; EIR=environmental impact report; GHG=greenhouse gas; ICAPCD=Imperial County Air Pollution Control District; IID=Imperial Control District; LOS=level of service; RE=renewable energy; ROW=right-of-way

County of Imperial Land Use Ordinance

The County’s Land Use Ordinance provides the physical land use planning criteria for development within the jurisdiction of the County. The Land Use Ordinance identifies the permitted and conditional uses within a zoning designation. Uses identified as conditionally permitted require a CUP, which is subject to the discretionary approval of the County Board of Supervisors per a recommendation by the County Planning Commission.

PERMITTED AND CONDITIONAL USES

A-3 Zoning. As shown on Figure 3.11-2, the project site is zoned Heavy Agriculture with a Renewable Energy Zone Overlay (A-3-RE). Pursuant to Title 9, Division 5, Chapter 9, the purpose of the A-3 zoning designation is to “designate areas that are suitable for agricultural land uses; to prevent the encroachment of incompatible uses onto and within agricultural lands; and to prohibit the premature conversion of such lands to non-agricultural uses. It is a land use that is to promote the heaviest of agricultural uses in the most suitable land areas of the county. Uses in the A-3 zoning designation are limited primarily to agricultural related uses and agricultural activities that are compatible with agricultural uses” (County of Imperial 2020).

Uses in the A-3 zoning designation are limited primarily to agricultural-related uses and agricultural activities that are compatible with agricultural uses. Pursuant to Title 9, Division 5, Chapter 9, the following uses are permitted in the A-3 zone subject to approval of a CUP from Imperial County:

i) Battery Storage Facility (must be connected to an existing electrical power generation plant such as solar, geothermal, wind, natural gas, or other renewable energy generator, as an accessory unit to said power plant).

oo) Major facilities relating to the generation and transmission of electrical energy, provided such facilities are not under State or Federal law, to [be] approved exclusively by an agency, or agencies of the State or Federal government, and provided such facilities shall be approved subsequent to coordination review of the Imperial Irrigation District for electrical matters, meeting the requirements in Division 17.

zz) Solar energy plants meeting the requirements in Division 17.

Height Limit. Section 90509.07 of the Land Use Ordinance limits the height of all non-residential structures and specifically states in Section 90509.07 (C) that, “Non-Residential structures and commercial communication towers shall not exceed one hundred twenty (120) feet in height, and as may be required by the airport land use compatibility plan (ALUCP).” The height of the proposed gen-tie transmission structures would be 60 feet.

RE Resources. According to Title 9, Division 17 of the Land use Ordinance, the purpose of the RE Resources regulations are to “facilitate the beneficial use of renewable energy resources for the general welfare of the people of Imperial County and the State of California; to protect renewable energy resources from wasteful or detrimental uses; and to protect people, property, and the environment from detriments that might result from the improper use of renewable energy resources” (County of Imperial 2017).

Title 9, Division 17 of the Land Use Ordinance includes the RE Overlay Zone, which authorizes the development and operation of renewable energy projects, with an approved CUP. Uses that are conditionally permitted require and require a CUP are subject to the discretionary approval of the County Board of Supervisors (Board) per a recommendation by the County Planning Commission.

Imperial County Airport Land Use Compatibility Plan

The Imperial County Airport Land Use Compatibility Plan (ALUCP) provides the criteria and policies used by the Imperial County Airport Land Use Commission to assess compatibility between the principal airports in Imperial County and proposed land use development in the areas surrounding the airports. The ALUCP emphasizes review of local general and specific plans, zoning ordinances, and other land use documents covering broad geographic areas.

The nearest airports to the project site are the Calexico International Airport located approximately 10 miles west of the project site and Holtville Airport located approximately 10 miles north of the project site. According to Figure 3B (Compatibility Map – Calexico International Airport) and Figure 3D (Compatibility Map – Holtville Airport) of the ALUCP, no portion of the project site is located within the Calexico International Airport or Holtville Airport’s land use compatibility zones (County of Imperial 1996).

3.11.3 Impacts and Mitigation Measures

Thresholds of Significance

Based on CEQA Guidelines Appendix G, project impacts related to land use/planning are considered significant if any of the following occur:

- Physically divide an established community
- Cause a significant environmental impact due to a conflict with any land use plan, policy, or regulation adopted for the purpose of avoiding or mitigating an environmental effect

Methodology

The project’s consistency with applicable federal, state, and local land uses plans and policies was evaluated in order to analyze land use consistency and land use impacts. The approach employed included:

- Review of the proposed project relative to the land use assumptions, policies, and designations of the Imperial County General Plan and applicable land use plans, policies, and regulations.
- Identification of potential conflicts between the proposed land uses and existing or proposed land uses in the vicinity.

In some instances, the land use for the project poses potential physical environmental consequences, such as traffic. In these cases, the consequences are discussed in the specific section of this EIR that focuses on that issue. The conceptual site plan for the project was also used to evaluate potential impacts.

Impact Analysis

Impact **Would the project physically divide an established community?**
3.11-1

The project site is located in a sparsely populated portion of Imperial County. There are no established residential communities located within or in the vicinity of the project site. The nearest established residential community is located approximately 10 miles west of the project site in Calexico. Therefore, implementation of the proposed project would not divide an established community and no impact would occur.

Mitigation Measure(s)

No mitigation measures are required.

Impact 3.11-2 ***Would the project cause a significant environmental impact due to a conflict with any land use plan, policy, or regulation adopted for the purpose of avoiding or mitigating an environmental effect?***

The project's consistency with applicable land use plans, policies, and regulations is evaluated below.

SCAG 2020-2045 RTP/SCS (Connect SoCal)

As noted above, the 2020-2045 RTP/SCS (Connect SoCal) (SCAG 2020) identifies two goals which include reducing GHG emissions to improve air quality (Goal 5), and to promote conservation of natural and agricultural lands (Goal 10).

The 2020-2045 RTP/SCS (Connect SoCal), identifies strategies to support the goal of reducing regional GHG and improve air quality. Strategies include leveraging technological innovations including incorporating solar energy, hydrogen fuel cell power storage, and power generation. Once in operation, the proposed project would contribute to SCAG's goal in reducing GHG emissions and improving air quality.

The 2020-2045 RTP/SCS (Connect SoCal) also discusses the decline of agricultural land as an issue for the economy. The proposed project would temporarily convert Farmland of Local Importance to non-agricultural uses. However, as a condition of project approval (CUP condition), the project applicant or its successor in interest will be responsible for implementing a reclamation plan when the project is decommissioned at the end of its lifespan. The reclamation plan includes the removal, recycling, and/or disposal of all solar arrays, inverters, transformers, and other structures on the project site, as well as restoration of the site to its pre-project condition. Therefore, the proposed project would not permanently convert Farmland of Local Importance to non-agricultural uses. Therefore, no impacts due to a conflict with the 2020-2045 RTP/SCS (Connect SoCal) would occur.

County of Imperial General Plan

The County's General Plan applies to the solar energy facility and supporting infrastructure portions associated with the project. An analysis of the project's consistency with the General Plan goals and objectives relevant to the project is provided in Table 3.11-1. As shown in Table 3.11-1, the proposed project would generally be consistent with the goals and objectives of the General Plan. No amendment to the General Plan for a zone change would be required because the project site is entirely within the RE Overlay Zone. Therefore, no impacts due to a conflict with the General Plan would occur.

County of Imperial Land Use Ordinance

Development of the solar energy facility and supporting is subject to the County's zoning ordinance. The solar energy facility is located on two privately-owned legal parcels zoned A-3-RE. Pursuant to Title 9, Division 5, Chapter 9, the following uses are permitted in the A-3 zone subject to approval of a CUP from Imperial County:

- i) Battery Storage Facility (must be connected to an existing electrical power generation plant such as solar, geothermal, wind, natural gas, or other renewable energy generator, as an accessory unit to said power plant).*
- oo) Major facilities relating to the generation and transmission of electrical energy, provided such facilities are not under State or Federal law, to [be] approved exclusively by an agency,*

or agencies of the State or Federal government, and provided such facilities shall be approved subsequent to coordination review of the Imperial Irrigation District for electrical matters, meeting the requirements in Division 17.

zz) Solar energy plants meeting the requirements in Division 17.

Therefore, with approval of a CUP for the project, the proposed project would not conflict with the County's zoning ordinance.

Title 9, Division 17 of the Land use Ordinance, includes the RE Overlay Zone, which authorizes the development and operation of renewable energy projects, with an approved CUP. Therefore, the proposed project qualifies as a permitted use with the approval of a CUP by the County to allow for the construction and operation of the proposed solar energy facility. With approval of a CUP, the proposed project would not conflict with the County's zoning ordinance. No impacts due to a conflict with the County of Imperial Land Use Ordinance(s) would occur.

Imperial County Airport Land Use Compatibility Plan

As discussed above in Section 3.11.2, the nearest airports to the project site are the Calexico International Airport located approximately 10 miles west of the project site and Holtville Airport located approximately 10 miles north of the project site. According to Figure 3B (Compatibility Map – Calexico International Airport) and Figure 3D (Compatibility Map – Holtville Airport) of the ALUCP, no portion of the project site is located within the Calexico International Airport or Holtville Airport's land use compatibility zones (ALUC 1996). Therefore, the proposed project would not conflict with the Imperial County ALUCP, and no significant impact would occur.

Mitigation Measure(s)

No mitigation measures are required.

3.11.4 Decommissioning/Restoration and Residual Impacts

Decommissioning/Restoration

Decommissioning and restoration would not physically divide an established community or conflict with any applicable land use plans, policies, or regulations. Decommissioning would be conducted in compliance with a required Reclamation Plan that would be implemented at the end of the proposed project's life and would adhere to Imperial County's decommissioning requirements. Further, decommissioning activities would be subject to mandatory compliance with applicable local, State, and federal regulations designed to avoid adverse impacts to the project area and surrounding environment. Therefore, environmental impacts due to a conflict with an applicable land use plan, policy or regulation would be less than significant.

Residual

With the approval of a CUP and reclamation plan to address post-project decommissioning, the proposed project would generally be consistent with applicable state, regional, and local plans and policies. Based on these circumstances, the proposed project would not result in any residual significant and unmitigable land use impacts.

This page is intentionally blank.

3.12 Noise and Vibration

This section identifies the ambient noise environment for the project area and describes applicable federal, state, and local regulations, potential project-related noise and vibration impacts, and recommended mitigation measures to avoid or reduce potential impacts of the proposed project. The information for this section is summarized from a project-specific Noise Impact Assessment, prepared by ECORP Consulting, Inc. This report is included in Appendix J of this EIR.

3.12.1 Existing Conditions

Noise

Noise is defined as unwanted sound. Pressure waves traveling through air exert a force registered by the human ear as sound. Sound, traveling in the form of waves from a source, exerts a sound pressure level (referred to as sound level), which is measured in decibels (dB), with zero dB corresponding roughly to the threshold of human hearing and 120 to 140 dB corresponding to the threshold of pain.

The typical human ear is not equally sensitive to all frequencies of the audible sound spectrum. Consequently, when assessing potential noise impacts, sound is measured using an electronic filter that de-emphasizes the frequencies below 1,000 hertz (Hz) and above 5,000 Hz to imitate the human ear's decreased sensitivity to low and extremely high frequencies. This emulation of the human ear's frequency sensitivity is referred to as A-weighting and is expressed in units of dBA. Frequency A weighting follows an international standard method of frequency de-emphasis and is typically applied to community noise measurements. In practice, the specific sound level from a source is measured using a meter incorporating an electrical filter corresponding to the A-weighting curve. All noise levels reported are A-weighted unless otherwise stated.

The dB scale is logarithmic and an increase of 10 dBA is generally perceived as a doubling in loudness. For example, a 70-dBA sound is half as loud as an 80-dBA sound and twice as loud as a 60-dBA sound.

Typical noise levels associated with common noise sources are depicted in Figure 3.12-1.

Figure 3.12-1. Common Noise Levels

Common Outdoor Activities	Noise Level (dBA)	Common Indoor Activities
<u>Jet Fly-over at 300m (1000 ft)</u>	110	<u>Rock Band</u>
<u>Gas Lawn Mower at 1 m (3 ft)</u>	100	
<u>Diesel Truck at 15 m (50 ft), at 80 km (50 mph)</u>	90	<u>Food Blender at 1 m (3 ft)</u>
<u>Noisy Urban Area, Daytime</u>	80	<u>Garbage Disposal at 1 m (3 ft)</u>
<u>Gas Lawn Mower, 30 m (100 ft)</u>	70	<u>Vacuum Cleaner at 3 m (10 ft)</u>
<u>Commercial Area</u>		<u>Normal Speech at 1 m (3 ft)</u>
<u>Heavy Traffic at 90 m (300 ft)</u>	60	
<u>Quiet Urban Daytime</u>	50	<u>Large Business Office</u>
		<u>Dishwasher Next Room</u>
<u>Quiet Urban Nighttime</u>	40	<u>Theater, Large Conference</u>
<u>Quiet Suburban Nighttime</u>		<u>Room (Background)</u>
	30	<u>Library</u>
<u>Quiet Rural Nighttime</u>		<u>Bedroom at Night,</u>
	20	<u>Concert Hall (Background)</u>
		<u>Broadcast/Recording Studio</u>
	10	
<u>Lowest Threshold of Human Hearing</u>	0	<u>Lowest Threshold of Human Hearing</u>

Source: Appendix J of this EIR

Sound Propagation and Attenuation

Noise can be generated by a number of sources, including mobile sources such as automobiles, trucks and airplanes, and stationary sources such as construction sites, machinery, and industrial operations. Sound spreads (propagates) uniformly outward in a spherical pattern, and the sound level decreases (attenuates) at a rate of approximately 6 dB for each doubling of distance from a stationary or point source. Sound from a line source, such as a highway, propagates outward in a cylindrical pattern, often referred to as cylindrical spreading. Sound levels attenuate at a rate of approximately 3 dB for each doubling of distance from a line source, such as a roadway, depending on ground surface characteristics. No excess attenuation is assumed for hard surfaces like a parking lot or a body of water. Soft surfaces, such as soft dirt or grass, can absorb sound, so an excess ground-attenuation

value of 1.5 dB per doubling of distance is normally assumed. For line sources, an overall attenuation rate of 3 dB per doubling of distance is assumed (Appendix J of this EIR).

Noise levels may also be reduced by intervening structures; generally, a single row of detached buildings between the receptor and the noise source reduces the noise level by about 5 dBA, while a solid wall or berm generally reduces noise levels by 10 to 20 dBA. However, noise barriers or enclosures specifically designed to reduce site-specific construction noise can provide a sound reduction of 35 dBA or greater. To achieve the most potent noise-reducing effect, a noise enclosure/barrier must physically fit in the available space, must completely break the “line of sight” between the noise source and the receptors, must be free of degrading holes or gaps, and must not be flanked by nearby reflective surfaces (Appendix J of this EIR).

The manner in which older homes in California were constructed generally provides a reduction of exterior-to-interior noise levels of about 20 to 25 dBA with closed windows. The exterior-to-interior reduction of newer residential units is generally 30 dBA or more. Generally, in exterior noise environments ranging from 60 dBA Community Noise Equivalent Level (CNEL) to 65 dBA CNEL, interior noise levels can typically be maintained below 45 dBA, a typically residential interior noise standard, with the incorporation of an adequate forced air mechanical ventilation system in each residential building, and standard thermal-pane residential windows/doors with a minimum rating of Sound Transmission Class (STC) 28. (STC is an integer rating of how well a building partition attenuates airborne sound (Appendix J of this EIR).

Noise Descriptors

The decibel scale alone does not adequately characterize how humans perceive noise. The dominant frequencies of a sound have a substantial effect on the human response to that sound. Several rating scales have been developed to analyze the adverse effect of community noise on people. Because environmental noise fluctuates over time, these scales consider that the effect of noise on people is largely dependent on the total acoustical energy content of the noise, as well as the time of day when the noise occurs. The L_{eq} is a measure of ambient noise, while the L_{dn} and CNEL (Community Noise Equivalent Level) are measures of community noise.

The A weighted decibel sound level scale gives greater weight to the frequencies of sound to which the human ear is most sensitive. Because sound levels can vary markedly over a short period of time, a method for describing either the average character of the sound or the statistical behavior of the variations must be utilized. Most commonly, environmental sounds are described in terms of an average level that has the same acoustical energy as the summation of all the time-varying events.

Human Response to Noise

The human response to environmental noise is subjective and varies considerably from individual to individual. Noise in the community has often been cited as a health problem, not in terms of actual physiological damage, such as hearing impairment, but in terms of inhibiting general well-being and contributing to undue stress and annoyance. The health effects of noise in the community arise from interference with human activities, including sleep, speech, recreation, and tasks that demand concentration or coordination. Hearing loss can occur at the highest noise intensity levels.

Noise environments and consequences of human activities are usually well represented by median noise levels during the day or night or over a 24-hour period. Environmental noise levels are generally considered low when the CNEL is below 60 dBA, moderate in the 60 to 70 dBA range, and high above 70 dBA. Examples of low daytime levels are isolated, natural settings with noise levels as low as 20

dBA and quiet, suburban, residential streets with noise levels around 40 dBA. Noise levels above 45 dBA at night can disrupt sleep. Examples of moderate-level noise environments are urban residential or semi-commercial areas (typically 55 to 60 dBA) and commercial locations (typically 60 dBA). Regarding increases in A-weighted noise levels (dBA), the following relationships should be noted in understanding this analysis:

- Except in carefully controlled laboratory experiments, a change of 1 dBA cannot be perceived by humans.
- Outside of the laboratory, a 3-dBA change is considered a just-perceivable difference.
- A change in level of at least 5 dBA is required before any noticeable change in community response would be expected. An increase of 5 dBA is typically considered substantial.
- A 10-dBA change is subjectively heard as an approximate doubling in loudness and would almost certainly cause an adverse change in community response.

Existing Ambient Noise Levels

The project site consists of flat undeveloped land and is bound by agricultural land to the north with SR 98 beyond, agricultural land to the west, vacant undisturbed land to the east, and a mix of vacant undisturbed and agricultural land to the south. In order to quantify existing ambient noise levels in the project area, ECORP Consulting, Inc. conducted three short-term noise measurements on January 12, 2021. The noise measurement sites were representative of typical existing noise exposure within and adjacent to the project site during the daytime. The 15-minute measurements were taken between 1:51 p.m. and 2:45 p.m. Short-term (L_{eq}) measurements are considered representative of the noise levels throughout the day. As shown in Table 3.12-1, the existing noise levels (baseline) in the project vicinity range from 65.4 to 68.7 dBA.

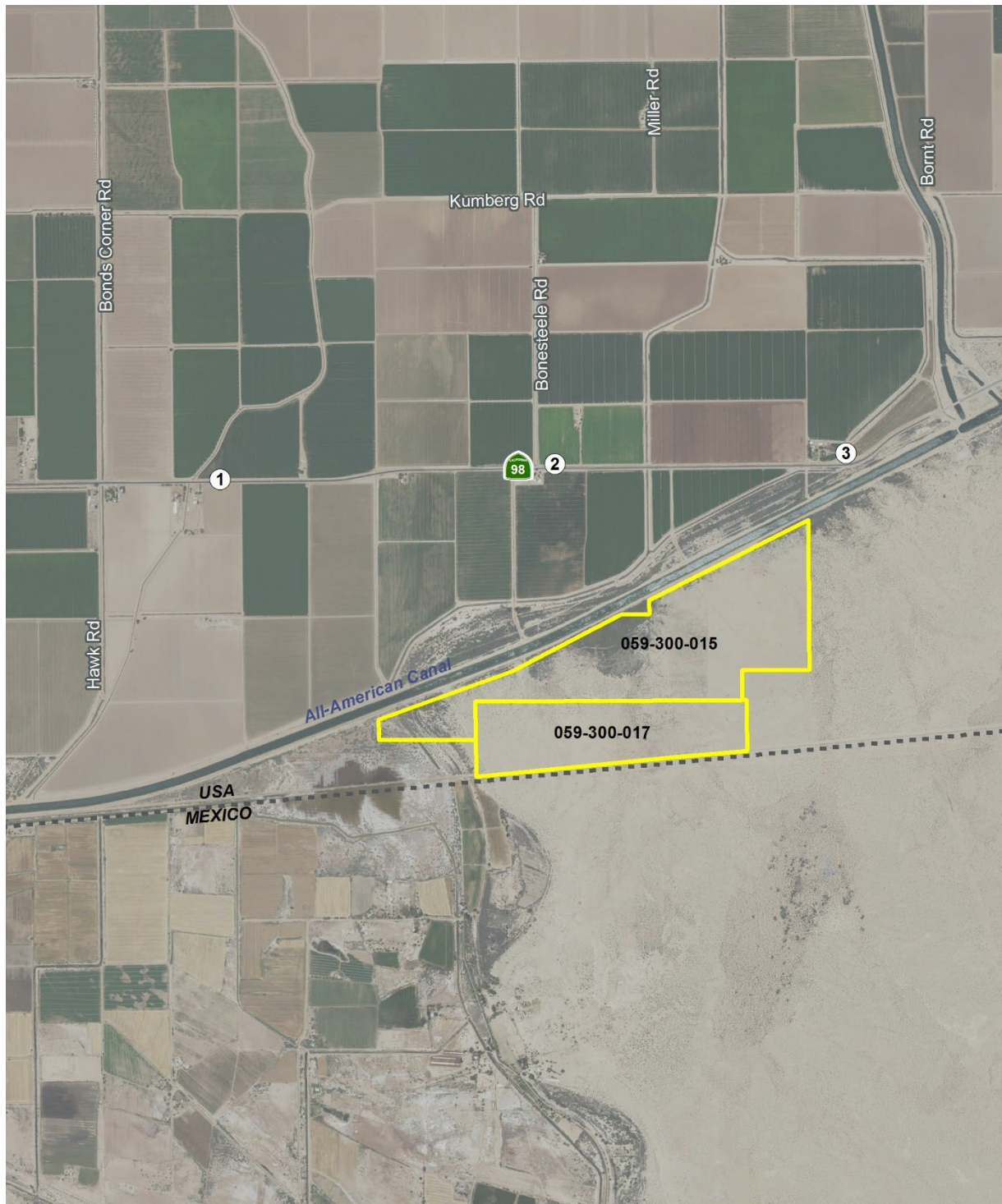
Table 3.12-1. Existing (Baseline) Noise Measurements

Measurement Location Number	Location	L_{eq} dBA	L_{min} dBA	L_{max} dBA	Time
1	CA-98 East of Bonds Corner Road	65.4	36.3	79.8	2:30 p.m.- 2:45 p.m.
2	CA-98 East of Bonesteel Road	68.7	25.2	86.2	2:10 p.m. – 2:25 p.m.
3	CA-98 Southeastern Extent	66.1	40.8	81.5	1:51 p.m. – 2:06 p.m.

Source: Appendix J of this EIR

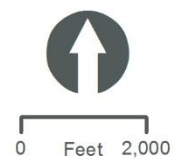
The most common noise in the project vicinity is produced by automotive vehicles (e.g., cars, trucks, buses, motorcycles) traveling on SR 98. Traffic moving along streets produces a sound level that remains relatively constant and is part of the minimum ambient noise level in the project vicinity.

Figure 3.12-2. Noise Measurement Locations



Legend

- VEGA SES 4 Project Parcels
- Noise Measurement Location



Noise Sensitive Land Uses

Noise-sensitive land uses are generally considered to include those uses where noise exposure could result in health-related risks to individuals, as well as places where quiet is an essential element of their intended purpose. Residential dwellings are of primary concern because of the potential for increased and prolonged exposure of individuals to both interior and exterior noise levels. Additional land uses such as hospitals, historic sites, cemeteries, and certain recreation areas are considered sensitive to increases in exterior noise levels. Schools, churches, hotels, libraries, and other places where low interior noise levels are essential are also considered noise-sensitive land uses.

The nearest existing noise-sensitive land use to the project site is a single-family residence located approximately 1,342 feet from the northeastern corner of project site.

Vibration

Vibration Sources and Characteristics

Sources of earthborne vibrations include natural phenomena (e.g., earthquakes, volcanic eruptions, sea waves, landslides) or manmade causes (explosions, machinery, traffic, trains, construction equipment, etc.). Vibration sources may be continuous (e.g., factory machinery) or transient (e.g., explosions). Ground vibration consists of rapidly fluctuating motions or waves with an average motion of zero. Several different methods are typically used to quantify vibration amplitude. One is the peak particle velocity (PPV); another is the root mean square (RMS) velocity. The PPV is defined as the maximum instantaneous positive or negative peak of the vibration wave. The RMS velocity is defined as the average of the squared amplitude of the signal. The PPV and RMS vibration velocity amplitudes are used to evaluate human response to vibration.

PPV is generally accepted as the most appropriate descriptor for evaluating the potential for building damage. For human response, however, an average vibration amplitude is more appropriate because it takes time for the human body to respond to the excitation (the human body responds to an average vibration amplitude, not a peak amplitude). Because the average particle velocity over time is zero, the RMS amplitude is typically used to assess human response. The RMS value is the average of the amplitude squared over time, typically a 1- sec. period (Appendix J of this EIR).

Table 3.12-2 displays the reactions of people and the effects on buildings produced by continuous vibration levels. To sensitive individuals, vibrations approaching the threshold of perception can be annoying. Low-level vibrations frequently cause irritating secondary vibration, such as a slight rattling of windows, doors, or stacked dishes. The rattling sound can give rise to exaggerated vibration complaints, even though there is very little risk of actual structural damage. In high-noise environments, which are more prevalent where groundborne vibration approaches perceptible levels, this rattling phenomenon may also be produced by loud airborne environmental noise causing induced vibration in exterior doors and windows.

Ground vibration can be a concern in instances where buildings shake, and substantial rumblings occur. However, it is unusual for vibration from typical urban sources such as buses and heavy trucks to be perceptible. For instance, heavy-duty trucks generally generate groundborne vibration velocity levels of 0.006 PPV at 50 feet under typical circumstances, which as identified in Table 3.12-2 is considered very unlikely to cause damage to buildings of any type.



Table 3.12-2. Human Reaction and Damage to Buildings for Continuous or Frequent Intermittent Vibration Levels

Peak Particle Velocity (inches/second)	Approximate Vibration Velocity Level (VdB)	Human Reaction	Effect on Buildings
0.006 – 0.019	67 – 74	Range of threshold of perception	Vibrations unlikely to cause damage of any type
0.08	87	Vibrations readily perceptible	Recommended upper level to which ruins and ancient monuments should be subjected
0.1	92	Level at which continuous vibrations may begin to annoy people, particularly those involved in vibration sensitive activities	Virtually no risk of architectural damage to normal buildings
0.2	94	Vibrations may begin to annoy people in buildings	Threshold at which there is a risk of architectural damage to normal dwellings
0.4 – 0.6	98 - 104	Vibrations considered unpleasant by people subjected to continuous vibrations and unacceptable to some people walking on bridges	Architectural damage and possibly minor structural damage

Source: Appendix J of this EIR

Common sources for groundborne vibration are planes, trains, and construction activities such as earth-moving which requires the use of heavy-duty earth moving equipment. Construction-related ground vibration is normally associated with impact equipment such as pile drivers, jackhammers, and the operation of some heavy-duty construction equipment, such as dozers and trucks. Vibration decreases rapidly with distance. Groundborne vibration levels associated with typical construction equipment at 25 feet distant are summarized in Table 3.12-3.

Table 3.12-3. Representative Vibration Source Levels for Construction Equipment

Equipment Type	Peak Particle Velocity at 25 Feet (Inches per Second)
Large Bulldozer	0.089
Caisson Drilling	0.089
Loaded Trucks	0.076
Hoe Ram	0.089
Jackhammer	0.035
Small Bulldozer/Tractor	0.003
Vibratory Roller	0.210

Source: Appendix J of this EIR

Proximity to Airports

The project site is not located within 2 miles of a public airport or a public use airport. The nearest airports to the project site are the Calexico International Airport located approximately 10 miles west of the project site and Holtville Airport located approximately 10 miles north of the project site. According to the Imperial County Airports Department, the Holtville Airport is currently closed.

3.12.2 Regulatory Setting

This section identifies and summarizes federal, state, and local laws, policies, and regulations that are applicable to the project.

Federal

Occupational Safety and Health Act of 1970

OSHA regulates onsite noise levels and protects workers from occupational noise exposure. To protect hearing, worker noise exposure is limited to 90 dBA over an eight-hour work shift (29 Code of Regulations 1910.95). Employers are required to develop a hearing conservation program when employees are exposed to noise levels exceeding 85 dBA. These programs include provision of hearing protection devices and testing employees for hearing loss on a periodic basis.

State

State of California General Plan Guidelines

The State of California regulates vehicular and freeway noise affecting classrooms, sets standards for sound transmission and occupational noise control, and identifies noise insulation standards and airport noise/land-use compatibility criteria. The State of California General Plan Guidelines, published by the Governor's Office of Planning and Research (OPR), also provides guidance for the acceptability of projects within specific CNEL/ L_{dn} contours. The guidelines also present adjustment factors that may be used in order to arrive at noise acceptability standards that reflect the noise control goals of the community, the particular community's sensitivity to noise, and the community's assessment of the relative importance of noise pollution.

State Office of Planning and Research Noise Element Guidelines

The State OPR Noise Element Guidelines include recommended exterior and interior noise level standards for local jurisdictions to identify and prevent the creation of incompatible land uses due to noise. The Noise Element Guidelines contain a Land Use Compatibility table that describes the compatibility of various land uses with a range of environmental noise levels in terms of the CNEL. The County of Imperial has utilized the adjustment factors provided and has modified the state's Land Use Compatibility standards for the purpose of implementing the Noise Element of its General Plan. Table 3.12-4 summarizes the acceptable and unacceptable community noise exposure limits for various land use categories as currently defined by the State of California. These community noise exposure limits are also incorporated into the County of Imperial General Plan Noise Element.



Table 3.12-4. Land Use Compatibility for Community Noise Environments

Land Use Category	Community Noise Exposure – L _{dn} or CNEL (dBA)							
	50	55	60	65	70	75	80	
Residential	█	█	█	█				
			█	█	█			
						█	█	
							█	█
Transient Lodging – Motel, Hotel	█	█	█	█	█			
			█	█	█	█	█	
							█	█
Schools, Libraries, Churches, Hospitals, Nursing Homes	█	█	█					
			█	█	█			
						█	█	█
								█
Auditorium, Concert Hall, Amphitheaters								
	█	█	█	█	█	█		
						█	█	█
Sports Arena, Outdoor Spectator Sports								
	█	█	█	█	█	█	█	
							█	█
Playgrounds, Neighborhood Parks	█	█	█	█	█	█		
						█	█	
							█	█
Golf Courses, Riding Stables, Water Recreation, Cemeteries	█	█	█	█	█	█		
						█	█	█
								█
Office Buildings, Business, Commercial and Professional	█	█	█	█	█			
				█	█	█	█	
							█	█
Industrial, Manufacturing, Utilities, Agriculture	█	█	█	█	█	█		

Table 3.12-4. Land Use Compatibility for Community Noise Environments

Land Use Category		Community Noise Exposure – L _{dn} or CNEL (dBA)							
		50	55	60	65	70	75	80	
	Normally Acceptable	Specified land use is satisfactory, based upon the assumption that any buildings involved are of normal conventional construction, without any special noise insulation requirements.							
	Conditionally Acceptable	New construction or development should be undertaken only after a detailed analysis of the noise reduction requirements is made and needed noise insulation features are included in the design.							
	Normally Unacceptable	New construction or development should be discouraged. If new construction or development does proceed, a detailed analysis of the noise reduction requirement must be made and needed noise insulation features included in the design.							
	Clearly Unacceptable	New construction or development generally should not be undertaken.							

Source: OPR 2017; ICPDS 1993

CNEL - community noise equivalent level; dBA – A-weighted decibel; L_{dn} – day-night average sound level

Local

County of Imperial General Plan Noise Element

The County of Imperial General Plan Noise Element identifies and defines existing and future environmental noise levels from sources of noise within or adjacent to the County of Imperial; establishes goals and objectives to address noise impacts and provides Implementation Programs to implement adopted goals and objectives. Table 3.12-5 summarizes the project’s consistency with the applicable General Plan noise policies. While this EIR analyzes the project’s consistency with the General Plan pursuant to CEQA Guidelines Section 15125(d), the Imperial County Board of Supervisors ultimately determines consistency with the General Plan.

The County of Imperial has established the following interior noise standards to be considered in acoustical analyses:

- The interior noise standard for detached single family dwellings shall be 45 dB CNEL.
- The interior noise standard for schools, libraries, offices and other noise-sensitive areas where the occupancy is normally only in the daytime, shall be 50 dB averaged over a 1-hour period (L_{eq}(1)).



Table 3.12-5. Project Consistency with Applicable General Plan Noise Policies

General Plan Policies	Consistency with General Plan	Analysis
<p>1. Acoustical Analysis of proposed projects. The County shall require the analysis of proposed discretionary projects, which may generate excessive noise, or which may be impacted by existing excessive noise levels.</p>	<p>Consistent</p>	<p>Under existing conditions, the ambient noise environment is characterized as relatively quiet with peak noise levels influenced by vehicular traffic traveling on SR 98. Given that the project is not characterized as a sensitive land use, project facilities would be unaffected by existing noise levels. The project facilities would be constructed within areas zoned for agricultural use with noise levels up to 70 dBA identified as normally acceptable. Project operations are expected to produce noise levels that would not exceed County standards and, hence impacts are expected to be less than significant.</p> <p>This EIR provides an analysis of the potential short- and long-term noise impacts of the project. As discussed, short-term and long-term noise levels were found to be less than significant.</p>
<p>2. Noise/Land Use Compatibility. Where acoustical analysis of a proposed project is required, the County shall identify and evaluate potential noise/land use conflicts that could result from the implementation of the project. Projects which may result in noise levels that exceed the "Normally Acceptable" criteria of the Noise/Land Use Compatibility Guidelines shall include mitigation measures to eliminate or reduce the adverse noise impacts to an acceptable level.</p>	<p>Consistent</p>	<p>Noise levels associated with project operations would not exceed noise limits for the A-3 zone. See Section 3.12.3 for additional discussion.</p>
<p>4. Interior Noise Environment. Where acoustical analysis of a proposed project is required, the County shall identify and evaluate projects to ensure compliance to the California (Title 24) interior noise standards and the additional requirements of this Element.</p>	<p>Consistent</p>	<p>This EIR provides an analysis of the potential short- and long-term noise impacts of the project. As discussed, short-term and long-term noise levels were found to be less than significant.</p> <p>Noise levels associated with project operations would not exceed noise limits for the A-3 zone.</p>
<p>5. New Noise Generating projects. The County shall identify and evaluate projects which have the potential to generate noise in excess of the Property Line Noise Limits. An acoustical analysis must be submitted which demonstrates the project's compliance.</p>	<p>Consistent</p>	<p>This EIR provides an analysis of the potential short- and long-term noise impacts of the project. As discussed, short-term and long-term noise levels were found to be less than significant.</p> <p>Noise levels associated with project operations would not exceed noise limits for the A-3 zone.</p>

Table 3.12-5. Project Consistency with Applicable General Plan Noise Policies

General Plan Policies	Consistency with General Plan	Analysis
6. Projects Which Generate Off-site Traffic Noise. The acoustical analysis shall identify and evaluate projects, which would generate traffic and increase noise levels on off-site roadways. If the project site has the potential to cause a significant noise impact on sensitive receptors along those roadways, the acoustical analysis report shall consider noise reduction measures to reduce the impact to a level less than significant.	Consistent	As described in Chapter 2, the project would involve a minimal number of operational related vehicle trips and therefore, is unlikely to produce any increase in traffic noise levels on local roadways.

Source: ICPDS 1993

Construction Noise Standards

Construction noise, from a single piece of equipment or a combination of equipment, shall not exceed 75 dB L_{eq} , when averaged over an eight (8) hour period, and measured at the nearest sensitive receptor. This standard assumes a construction period, relative to an individual sensitive receptor of days or weeks. In cases of extended length construction times, the standard may be tightened so as not to exceed 75 dB L_{eq} when averaged over a one (1) hour period.

Construction equipment operation are required to be limited to the hours of 7:00 a.m. to 7:00 p.m., Monday through Friday, and 9:00 a.m. to 5:00 p.m. Saturday. No commercial construction operations are permitted on Sunday or holidays. In cases of a person constructing or modifying a residence for himself/herself, and if the work is not being performed as a business, construction equipment operations may be performed on Sundays and holidays between the hours of 9:00 a.m. and 5:00 p.m. Such non-commercial construction activities may be further restricted where disturbing, excessive, or offensive noise causes discomfort or annoyance to reasonable persons of normal sensitivity residing in an area.

County of Imperial Noise Ordinance

Noise generating sources in Imperial County are regulated under the County of Imperial Codified Ordinances, Title 9, Division 7 (Noise Abatement and Control). Noise limits are established in Chapter 2 of this ordinance. Under Section 90702.00 of this rule, 70 dB is the normally acceptable limit for the Industrial, Manufacturing, Utilities, and Agricultural category of land use (Table 3.12-6).



Table 3.12-6. Imperial County Exterior Noise Standards

Land Use Zone	Time Period	Noise Level, L_{eq} 1-hour
R-1 Residential	Night (10 p.m. to 7 a.m.)	45 dBA
	Day (7 a.m. to 10 p.m.)	50 dBA
R-2 Residential	Night (10 p.m. to 7 a.m.)	50 dBA
	Day (7 a.m. to 10 p.m.)	55 dBA
R-3, R-4, and all other residential	Night (10 p.m. to 7 a.m.)	50 dBA
	Day (7 a.m. to 10 p.m.)	55 dBA
Commercial	Night (10 p.m. to 7 a.m.)	55 dBA
	Day (7 a.m. to 10 p.m.)	60 dBA
Manufacturing, other industrial, agricultural, and extraction industry	Anytime	70 dBA
Industrial	Anytime	75 dBA

dBA – A-weighted decibel; L_{eq} – equivalent sound level

Imperial County Right-to-Farm Ordinance

In recognition of the role of agriculture in the county, the County of Imperial has adopted a “right-to-farm” ordinance (County of Imperial Codified Ordinances, Division 2, Title 6: Right to Farm). A “right-to-farm” ordinance creates a legal presumption that ongoing standard farming practices are not a nuisance to adjoining residences and requires a disclosure to landowners near agricultural land operations or areas zoned for agricultural purposes. The disclosure advises persons regarding potential discomfort and inconvenience that may occur from operating machinery as a result of conforming and accepted agricultural operations.

3.12.3 Impacts and Mitigation Measures

This section presents the significance criteria used for considering project impacts on biological resources, the methodology employed for the evaluation, an impact evaluation, and mitigation requirements, if necessary.

Thresholds of Significance

Based on CEQA Guidelines Appendix G, project impacts related to noise and vibration are considered significant if any of the following occur:

- Generate a substantial temporary or permanent increase in ambient noise levels in the vicinity of the project in excess of standards established in the local general plan or noise ordinance, or applicable standards of other agencies.
- Generate excessive groundborne vibration or groundborne noise levels.
- For a project located in the vicinity of a private airstrip of an airport land use plan, or where such a plan has not been adopted, within two miles of a public airport or public use airport,

would the project expose people residing or working in the project area to excessive noise levels.

Methodology

Noise and Vibration

This analysis of the existing and future noise environments is based on empirical observations. Predicted construction noise levels were calculated utilizing the FHWA's Roadway Construction Model (see Appendix J of this EIR for details). Groundborne vibration levels associated with construction-related activities for the project were evaluated utilizing typical groundborne vibration levels associated with construction equipment. Potential groundborne vibration impacts related to structural damage and human annoyance were evaluated, taking into account the distance from construction activities to nearby structures and typically applied criteria for structural damage and human annoyance.

In order to estimate the worst-case operational noise levels that may occur at the nearest noise-sensitive receptor, onsite operational noise levels have been calculated with the SoundPLAN 3D noise model (which predicts noise propagation from a noise source based on the location, noise level, and frequency spectra of the noise sources as well as the geometry and reflective properties of the local terrain, buildings, and barriers), coupled with noise measurements that were taken by ECORP Consulting, Inc. (ECORP) at an existing solar energy generation facility. Specifically, ECORP conducted a 30-minute reference noise measurement within the IVC solar generation facility in Imperial County with a Larson Davis SoundExpert LxT precision sound-level meter, which satisfies the American National Standards Institute for general environmental noise measurement instrumentation. This reference measurement identified an ambient noise environment of 47.1 dBA at the existing solar energy generation facility (see Appendix J of this EIR for details). Therefore, a noise level of 47.1 dBA was employed as the reference noise level in the SoundPLAN 3D noise model to determine noise-level propagation associated with project operations.

Impact Analysis

Impact 3.12-1 Would the project generate a substantial temporary or permanent increase in ambient noise levels in the vicinity of the project in excess of standards established in the local general plan or noise ordinance, or applicable standards of other agencies?

Onsite Construction Noise

Construction noise associated with the proposed project would be temporary and would vary depending on the nature of the activities being performed. Noise generated would primarily be associated with the operation of off-road equipment for onsite construction activities as well as construction vehicle traffic on area roadways. Construction noise typically occurs intermittently and varies depending on the nature or phase of construction (e.g., land clearing, grading, excavation, paving). Noise generated by construction equipment, including earth movers, material handlers, and portable generators, can reach high levels. Typical operating cycles for these types of construction equipment may involve one or two minutes of full power operation followed by three to four minutes at lower power settings. Other primary sources of acoustical disturbance would be random incidents, which would last less than one minute (such as dropping large pieces of equipment or the hydraulic



movement of machinery lifts). During construction, exterior noise levels could negatively affect sensitive land uses in the vicinity of the construction site.

Nearby noise-sensitive land uses consist of a scattering of single-family residential units located within 1 mile of the proposed project site boundary to the north across the All-American Canal. The closest sensitive receptor is located approximately 1,342 feet from the northeastern corner of the project site. As previously described, the County’s General Plan Noise Element states construction equipment operation shall be limited to the hours of 7:00 a.m. to 7:00 p.m., Monday through Friday, and 9:00 a.m. to 5:00 p.m. on Saturdays. No commercial construction operations are permitted on Sundays or holidays. Construction noise, from a single piece of equipment or a combination of equipment, shall not exceed 75 dB L_{eq}, when averaged over an 8-hour period, and measured at the nearest sensitive receptor. This standard assumes a construction period, relative to an individual sensitive receptor of days or weeks. In cases of extended length construction times, the standard may be tightened so as not to exceed 75 dB L_{eq} when averaged over a one 1-hour period.

The anticipated short-term construction noise levels generated for the necessary construction equipment are presented in Table 3.12-7.

Table 3.12-7. Construction Average Noise Levels (dBA) at the Nearest Receptor

Equipment	Estimated Exterior Construction Noise Level at Nearest Receptor	Construction Noise Standards (dBA L _{eq})	Exceeds Standards?
Site Preparation			
Rubber Tired Dozers (2)	46.6 (each)	75	No
Tractors/Loaders/Backhoes (2)	51.4 (each)	75	No
Combined Site Preparation Equipment	55.7	75	No
Grading			
Excavators (4)	48.2 (each)	75	No
Graders (3)	52.4 (each)	75	No
Rubber Tired Dozers (2)	49.1 (each)	75	No
Scrapers (2)	51 (each)	75	No
Tractors/Loaders/Backhoes (4)	51.4 (each)	75	No
Combined Grading Equipment	62.5	75	No
Facility Construction			
Crane	44.0 (each)	75	No
Paver	45.6 (each)	75	No
Paving Equipment (2)	53.9 (each)	75	No
Pile Drivers (4)	65.7 (each)	75	No
Rollers (2)	44.4 (each)	75	No

Table 3.12-7. Construction Average Noise Levels (dBA) at the Nearest Receptor

Equipment	Estimated Exterior Construction Noise Level at Nearest Receptor	Construction Noise Standards (dBA Leq)	Exceeds Standards?
Rough Terrain Forklifts (4)	50.8 (each)	75	No
Tractors/Loaders/Backhoes	51.4 (each)	75	No
Trenchers (2)	48.8 (each)	75	No
Combined Construction, Trenching, and paving	72.2	75	No

Source: Appendix J of this EIR

Notes: The nearest residence is located approximately 1,342 feet from the project boundary.

Leq = The equivalent energy noise level, is the average acoustic energy content of noise for a stated period of time. Thus, the Leq of a time-varying noise and that of a steady noise are the same if they deliver the same acoustic energy to the ear during exposure. For evaluating community impacts, this rating scale does not vary, regardless of whether the noise occurs during the day or the night.

As shown in Table 3.12-7, no individual or cumulative pieces of construction equipment would exceed the 75 dBA Imperial County construction noise standard during any phase of construction at the nearest noise-sensitive receptor. Therefore, the proposed project would not generate a substantial temporary increase in ambient noise levels in the vicinity of the project in excess of standards established in the local general plan or noise ordinance, or applicable standards of other agencies during construction. Impacts would be less than significant.

Offsite Construction Worker Traffic Noise

Project construction would also result in additional traffic on adjacent roadways over the time period that construction occurs. The number of on-site construction workers for the proposed project is not expected to exceed 150 workers at any one time. The number of on-site construction workers for the battery storage facility and the substation is not expected to exceed 100 workers at any one time. Onsite parking would be provided for all construction workers. According to the Traffic Impact Study prepared for the project (Appendix K of this EIR), a maximum of 510 daily automobile trips would be generated during project construction, accounting for construction worker commutes and equipment deliveries (see Appendix K of this EIR for details). The majority of these trips are expected to be accommodated on SR 98, SR 7, and Interstate 8.

Doubling of traffic on a roadway is required to result in an increase of 3 dB (outside of the laboratory, a 3-dBA change is considered a just-perceivable difference). SR 98 currently accommodates 2,400 average daily traffic trips, while SR 7 and Interstate 8 accommodate 6,700 average daily trips and 14,000 average daily trips, respectively. Thus, the estimated 510 daily trips during project construction would not result in a doubling of traffic on these facilities, and its contribution to existing traffic noise would not be perceptible.

Bonds Corner Road and West Heber Road are also projected to accommodate construction-related traffic with an estimated 69 daily trips on Bonds Corner Road and 5 daily trips on West Heber Road over the course of construction. These two facilities are classified as “minor arterial” roads by the County General Plan Circulation and Scenic Highways Element and are expected to accommodate approximately 14,800 daily trips. While the Circulation and Scenic Highways Element does not identify specific traffic counts for Bonds Corner Road, it estimates between 2,020 and 16,700 average daily



trips on West Heber Road. Thus, the estimated 510 daily trips during project construction would not result in a doubling of traffic on these facilities, and its contribution to existing traffic noise would not be perceptible.

Based on the considerations above, the proposed project would not generate a substantial temporary increase in ambient noise levels related to construction worker traffic in the vicinity of the project in excess of standards established in the local general plan or noise ordinance, or applicable standards of other agencies during construction. Impacts would be less than significant.

Operation

The main stationary operational noise associated with the project would be from the proposed transformers, inverters, substation, and transmission lines. Onsite project operations have been calculated using the SoundPLAN 3D noise model. As previously stated, a noise level of 47.1 dBA was employed as the reference noise level in the SoundPLAN 3D noise model to determine noise-level propagation associated with the project operations. Table 3.12-8 shows the predicted project noise levels at the nearest noise-sensitive land use, a single-family residence located approximately 1,343 feet north of the project site, across the All-American Canal.

Table 3.12-8. Modeled Operational Noise Levels at Nearest Sensitive Receptor

Location	Modeled Operational Noise Attributed to Project (L _{eq} dBA)	County Daytime Standard (L _{eq} dB)	County Nighttime Standard (L _{eq} dB)	Exceed Standard?
Property line of the nearest residence	32.4	50.0	45.0	No

Source: Appendix J of this EIR

Note: Reference noise measurement used to calculate Project onsite noise propagation identified at 47.1 dBA, per 30-minute measurements taken at a VEGA SES 4 solar generation facility in Imperial County.

As shown in Table 3.12-8, project operational noise would not exceed County daytime or nighttime standards.

Project operations would result in minimal additional traffic on adjacent roadways. The only visitors to the site would be that of repair or maintenance workers, whose presence at the site would be infrequent. Sporadic vehicle activity resulting from maintenance and operations trips would not result in a doubling of traffic, and therefore its contribution to existing traffic noise would not be perceptible.

Given the above, project operation would not generate a substantial permanent increase in ambient noise levels in the vicinity of the project in excess of standards established in the local general plan or noise ordinance, or applicable standards of other agencies during construction. Impacts would be less than significant.

Mitigation Measure(s)

No mitigation measures are required.

Impact 3.12-2 Would the project generate excessive groundborne vibration or groundborne noise levels?

Construction

Excessive groundborne vibration impacts result from continuously occurring vibration levels. Increases in groundborne vibration levels attributable to the project would be primarily associated with short-term construction-related activities. Construction on the project site would have the potential to result in varying degrees of temporary groundborne vibration, depending on the specific construction equipment used and the operations involved. Ground vibration generated by construction equipment spreads through the ground and diminishes in magnitude with increases in distance.

As stated in Section 3.12.1 above, construction-related ground vibration is normally associated with impact equipment such as pile drivers, jackhammers, and the operation of some heavy-duty construction equipment, such as dozers and trucks. Vibration decreases rapidly with distance and it is acknowledged that construction activities would occur throughout the project site and would not be concentrated at the point closest to sensitive receptors. Groundborne vibration levels associated with typical construction equipment at 25 feet distant are summarized in Table 3.12-3.

The County of Imperial does not regulate vibrations associated with construction. However, a discussion of construction vibration is included for informational purposes. Caltrans and the Federal Transit Authority (FTA) have developed two of the decisive works in the assessment of vibrations from transportation and construction sources (Caltrans 2020; FTA 2018). Caltrans recommends a standard threshold of 0.2 inch per second PPV with respect to the prevention of structural damage for older residential buildings (Caltrans 2020). This is also the level at which vibrations may begin to annoy people in buildings. Consistent with FTA recommendations (FTA 2018) for calculating construction vibration, construction vibration was measured from the center of the project site. The nearest structure of concern to the construction site, with regard to groundborne vibrations, is the All-American Canal located 100 feet from the proposed project site boundary (Appendix J of this EIR).

Potential project construction vibration levels were calculated based on the representative vibration levels presented for various construction equipment types in Table 3.12-3 and the construction vibration assessment methodology published by the FTA (FTA 2018). Table 3.12-9 presents the expected project-related vibration levels at a distance of 100 feet.

Table 3.12-9. Project Construction Vibration Levels at 100 Feet

Receiver PPV Levels (Inch per Second)					Peak Vibration	Threshold	Exceed Threshold?
Large Bulldozer, Caisson Drilling, and Hoe Ram	Loaded Trucks	Jackhammer	Small Bulldozer	Vibratory Roller			
0.011	0.009	0.004	0.000	0.026	0.026	0.2	No

Source: Appendix J of this EIR

As shown in Table 3.12-9, vibration as a result of construction activities would not exceed 0.2 PPV at the nearest structure. Thus, project construction would not exceed the recommended vibration threshold and this impact would be less than significant.

Operation

Project operations would not include the use of any large-scale stationary equipment that would result in excessive vibration levels, nor would it involve any operational activities that would result in excessive vibration. Therefore, the project would result in no impact associated with groundborne vibration during operations.

Mitigation Measure(s)

No mitigation measures are required.

Impact 3.12-3 For a project located in the vicinity of a private airstrip of an airport land use plan, or where such a plan has not been adopted, within two miles of a public airport or public use airport, would the project expose people residing or working in the project area to excessive noise levels?

The project site is not located within 2 miles of a public airport or a public use airport. The nearest airports to the project site are the Calexico International Airport located approximately 10 miles west of the project site and Holtville Airport located approximately 10 miles north of the project site. According to the Imperial County Airports Department, the Holtville Airport is currently closed. The Imperial County Airport Land Use Commission has established a set of land use compatibility criteria for lands surrounding the airports in Imperial County in the Imperial County Airport Land Use Compatibility Plan (ALUCP) (County of Imperial 1996). According to Figure 4G of the ALUCP, the project site is outside of the noise contours of the Calexico International Airport. Therefore, the project would not expose people residing or working in the project area to excessive noise levels and no impact would occur.

Mitigation Measure(s)

No mitigation measures are required.

3.12.4 Decommissioning/Restoration and Residual Impacts

Decommissioning/Restoration

Decommissioning or restoration of the solar facility would use similar equipment to what was evaluated in the construction noise and vibration analysis. Adhering to Imperial County standards for construction noise levels would reduce the noise and vibration impacts to below a level of significance.

Residual

Adhering to the Imperial County standards for construction noise levels would reduce the noise and vibration impacts to below a level of significance.

This page is intentionally blank.

3.13 Transportation

This section addresses the proposed project's impacts on traffic and the surrounding roadway network associated with construction and operation of the proposed project. The following discussion describes the existing conditions in the surrounding area, the existing federal, state, and local regulations regarding transportation, and an analysis of the potential impacts of the proposed project.

Information in this section is summarized from the Traffic Impact Study prepared by KOA. This report is included in Appendix K of this EIR.

3.13.1 Existing Conditions

Traffic Study Area

Intersections

The traffic study area for the proposed project includes the following intersections:

1. Site driveway and SR-98
2. Bonds Corner Road and SR-98
3. SR-98 and SR-7
4. SR-7 and Heber Road
5. SR-7 and south ramp
6. SR-7 and north ramp

Roadway Segments

The traffic study area for the proposed project includes the following roadway segments:

1. SR-98 from the project to the east
2. SR-98 from the project to Bonds Corner Road
3. SR-98 from Bonds Corner Road to SR-7
4. SR-7 from SR-98 to I-8
5. I-8 from SR-7 to SR-111

Existing Level of Service

Level of service (LOS) is a professional industry standard by which the operating conditions of a given roadway segment or intersection are measured. LOS ranges from A through F, where LOS A represents the best operating conditions and LOS F represents the worst operating conditions. LOS A facilities are characterized as having free flowing traffic conditions with no restrictions on maneuvering or operating speeds; traffic volumes are low and travel speeds are high. LOS F facilities are characterized as having forced flow with many stoppages and low operating needs.

Freeway Segments

The freeway segment (I-8 from SR-7 to SR-11) currently operates at acceptable LOS B in both directions under existing conditions.

Roadway Segments

All of the study area roadway segments analyzed currently operate at acceptable LOS A under existing conditions.

Intersections

All of the study area intersections analyzed currently operate at acceptable LOS B or better during the AM and PM peak hours under existing conditions.

Alternative/Public Transportation

Fixed Route Transportation

Imperial Valley Transit (IVT) is an inter-city fixed route bus system, subsidized by the Imperial Valley Association of Governments (IVAG), administered by the County Department of Public Works and operated by a public transit bus service. The service is wheelchair accessible and Americans with Disabilities Act compliant. IVT Routes are defined categorized in the following manner:

- **Fixed Routes.** Fixed routes operate over a set pattern of travel and with a published schedule. The fixed route provides a low cost, reliable, accessible and comfortable way to travel.
- **Deviated Fixed Route.** In several service areas, IVT operates on a deviated fixed route basis so that persons with disabilities and limited mobility are able to travel on the bus. Passengers must call and request this service the day before service is desired in the communities of Seeley, Ocotillo, and the east side of the Salton Sea.
- **Remote Zone Routes.** Remote zone routes operate once a week. These routes are "lifeline" in nature in that they provide connections from some of the more distant communities in the Imperial County area (IVT 2021).

The project site is not within the Fixed Route Transportation system and, therefore, would not receive regular bus service to the project site or within the vicinity of the project site. The nearest IVT bus stop is the 32D (Calexico to Brawley) bus stop on the southwest corner of Pauling Avenue and 3rd Street in the City of Calexico, which is approximately 10 miles west of the project site.

Bicycle Facilities

The project site is located within a rural portion of Imperial County. There are no bicycle facilities in the immediate proximity of the project site. There are no planned bike routes in immediate proximity to the project site.

Project Site Access

The project site is located within an unincorporated area of Imperial County, approximately 10 miles east of the City of Calexico. The triangular project site is somewhat isolated in that the All-American Canal and U.S./Mexico Border make up the northern and southern boundaries of the site. Vehicular access to the site is currently provided via an existing driveway along SR 98, just east of the project site.

3.13.2 Regulatory Setting

This section identifies and summarizes laws, policies, and regulations that are applicable to the proposed project.

State

California Department of Transportation

Caltrans manages more than 50,000 miles of California's highway and freeway lanes, provides inter-city rail services, permits more than 400 public-use airports and special-use hospital heliports, and works with local agencies. Specifically, Caltrans is responsible for the design, construction, maintenance, and operation of the California State Highway System.

As it relates to the proposed project and potential construction access routes within the County, Caltrans District 11 is responsible for maintaining and managing I-8, SR-98, and SR-7.

Regional

SCAG 2020-2045 RTP/SCS (Connect SoCal)

On September 3, 2020, SCAG adopted the 2020-2045 RTP/SCS (SCAG 2020). The RTP/SCS is a long-range visioning plan that balances future mobility and housing needs with economic, environmental and public health goals. Input from local governments, county transportation commissions, tribal governments, non-profit organizations, businesses, and local stakeholders within the counties of Imperial, Los Angeles, Orange, Riverside, San Bernardino, and Ventura. The 2020-2045 RTP/SCS demonstrates how the region will reduce emissions from transportation sources to comply with SB 375 and meet the NAAQS set forth by the Clean Air Act.

The updated RTP/SCS contains thousands of individual transportation projects that aim to improve the region's mobility and air quality and revitalize the economy. Since the RTP/SCS's adoption, the county transportation commissions have identified new project priorities and have experienced technical changes that are time-sensitive. Additionally, the new amendments for the plan have outlined minor modifications to project scopes, costs and/or funding and updates to completion years. The amendments to the RTP/SCS do not change any other policies, programs, or projects in the plan.

Local

County of Imperial Circulation and Scenic Highways Element

The Circulation and Scenic Highways Element identifies the location and extent of transportation routes and facilities. It is intended to meet the transportation needs of local residents and businesses and as a source for regional coordination. The inclusion of Scenic Highways provides a means of protecting and enhancing scenic resources within highway corridors in Imperial County. The purpose of the Circulation and Scenic Highways Element is to provide a comprehensive document which contains the latest knowledge about the transportation needs of the County and the various modes available to meet these needs. Additionally, the purpose of this Element is to provide a means of protecting and enhancing scenic resources within both rural and urban scenic highway corridors.

Coordination across jurisdictional standards for road classification and design standards was identified as a crucial component to the 2008 update of the Circulation and Scenic Highways Element. The intent

of this element is to provide a system of roads and streets that operate at a LOS “C” or better (County of Imperial 2008).

3.13.3 Impacts and Mitigation Measures

Thresholds of Significance

Based on CEQA Guidelines Appendix G, project impacts related to transportation and traffic are considered significant if any of the following occur:

- Conflict with a program plan, ordinance or policy addressing the circulation system, including transit, roadway, bicycle and pedestrian facilities
- Conflict with or be inconsistent with CEQA Guidelines section 15064.3, subdivision (b)
- Substantially increase hazards due to a geometric design feature (e.g., sharp curves or dangerous intersections) or incompatible uses (e.g., farm equipment)
- Result in inadequate emergency access

Methodology

County of Imperial

ROADWAY SEGMENT LEVEL OF SERVICE STANDARDS

The County of Imperial does not have published significance criteria for traffic impacts. However, the Circulation and Scenic Highways Element of the County General Plan does state that the LOS goal for intersections and roadway segments is to operate at LOS C or better. Therefore, if an intersection or segment degrades from LOS C or better to LOS D or worse with the addition of project traffic, the impact is considered significant. Furthermore, a project may result in a significant impact on Caltrans facilities if the new project traffic has decreased the operations of surrounding roadways and intersections by a defined threshold.

PEAK HOUR INTERSECTION LEVEL OF SERVICE STANDARDS

A project is considered to have a significant impact on Caltrans facilities if the project traffic has decreased the operations of surrounding roadways by a defined threshold. The Traffic Impact Study (Appendix K of this EIR) used principles of the specific analysis methods contained in the 2010 Highway Capacity Manual to analyze traffic conditions on roadway facilities. The analysis of peak hour intersection conditions was conducted using the Synchro 10 software program developed by Trafficware. Table 3.13-1 summarizes the LOS criteria for signalized and unsignalized intersections.

The County of Imperial traffic impact study guidelines consider LOS C or better during the AM and PM peak hours to be the threshold of significance for intersection LOS. Therefore, if the proposed project exceeds the County’s LOS C threshold for surrounding roadways intersections then the proposed project may have a significant project impact.



Table 3.13-1. HCM Level of Service Thresholds for Intersections

LOS	Signalized Intersection Delay (Seconds/Vehicle)	Unsignalized Intersection Average Stop Delay (Seconds/Vehicle)
A	0.0 ≤ 10.0	0.0 ≤ 10.0
B	10.1 to 20.0	10.1 to 15.0
C	20.1 to 35.0	15.1 to 25.0
D	35.1 to 55.0	25.1 to 35.0
E	55.1 to 80.0	35.1 to 50.0
F	≥ 80.0	≥ 50.0

Source: Appendix K of this EIR LOS – level of service

California Department of Transportation

Freeway LOS analysis is based upon procedures developed by Caltrans. The corresponding LOS listed in Table 3.13-2 represents an approximation of freeway operating conditions in the peak direction of travel during the peak hour. Constant with Caltrans requirements, LOS D or better is used as the threshold for acceptable freeway operations.

Therefore, if the proposed project results in impacts that would degrade the LOS of I-8, SR-98, and SR-7 to LOS E or F, then the proposed project would exceed LOS thresholds as set forth by the County and Caltrans and may have a significant project impact. A feasible mitigation measure will need to be identified to return the impact within the thresholds (pre-project + allowable increase) or the impact will be considered significant and unmitigated.

Table 3.13-2. Caltrans Freeway Segment Level of Service Definitions

LOS	Maximum Volume/Capacity	Congestion/Delay	Traffic Description
A	0.0 ≤ 0.30	None	Free flow.
B	> 0.30 to 50.0	None	Free to stable flow, light to moderate volumes.
C	> 50.0 to 0.71	None to Minimal	Stable flow, moderate volumes, freedom to maneuver noticeably restricted.
D	> 0.71 to 0.89	Minimal to Substantial	Approaches unstable flow, heavy volumes, very limited freedom to maneuver.
E	> 0.89 to 1.00	Significant	Extremely unstable flow, maneuverability and psychological comfort extremely poor.
F	>1.00	Considerable	Forced or breakdown flow. Delay measured in average travel speed (miles per hour [MPH]). Signalized segments experiences delays > 60.0 seconds/vehicle.

Source: Appendix K of this EIR LOS = level of service

Project Trip Generation

The proposed project will generate the most traffic during construction. The construction vehicle mix for both on-road and off-road equipment (e.g., dozers, loaders, excavators), by each phase of construction, is presented in Attachment A of the *Air Quality and Greenhouse Gas Assessment* prepared for the proposed project (Appendix C of this EIR).

The construction of the project is estimated to take 12-18 months and would begin in late 2022 and/or 2023. The number of on-site construction workers for the solar project facility is not expected to exceed 150 workers at any one time. The number of on-site construction workers for the battery storage facility and the substation is not expected to exceed 100 workers at any one time. The trip generation was estimated if the construction phases were to overlap, so both are included. Delivery trucks are expected to follow the same routes as the construction workers. An estimated two trucks would arrive at the project site each day during the first few weeks of construction of the solar generating facility. Truck trips have been converted into passenger equivalent volumes (PCE) using a PCE factor of 2.5.

Table 3.13-3 provides the estimated average daily on-road project trip generation (i.e., trips to and from the site) for the construction phases of the proposed project. As shown, the maximum number of on-road trips during construction would be approximately 520 daily trips ends (500 worker trips and 20 construction truck trips).

The proposed project requires minimal operations and maintenance activities and would not require presence of full-time employees. However, it is conservatively assumed that for day-to-day inspection and minor maintenance, some employees would commute to the project site. The annual operations are assumed to be as follows:

- For site inspection and minor repairs, up to 3 one-way worker trips per day would be generated.
- Routine maintenance activities would include panel washing, which is expected to occur two times annually.
- Periodic (approximately every 3 months) removal of vegetation manually and/or by treatment with herbicides.

Table 3.13-3. Construction Phase Trip Generation

Construction Phase (Duration)	Intensity (Unit)	Daily Rate	Daily Trip
Solar Construction Workers	150 (Employees)	2	300
Batter Storage Workers	150 (Employees)	2	200
Equipment Deliveries and Construction Truck Trips (PCE)	8 (trucks)	2.5	20
Total Daily Trips			520

Source: Appendix K of this EIR PCE = passenger equivalent volumes

Impact Analysis

Impact 3.13-1 Would the project conflict with a program plan, ordinance or policy addressing the circulation system, including transit, roadway, bicycle and pedestrian facilities?

During the construction phase of the proposed project, the maximum number of trip ends generated on a daily basis would be approximately 520 trips. Under construction year conditions with and without the proposed project, all roadway segments analyzed would operate at LOS A, all intersections would operate at a LOS B or better during both AM and PM peak hours, and all freeway segments would operate at LOS B or better during both AM and PM peak hours.

Implementation of the proposed project would not require any public road widening to accommodate vehicular trips associated with the proposed project (construction phase and operational phase), while maintaining adequate LOS. Additionally, future operations and maintenance would be conducted remotely, with minimal trips to the project site for panel washing and other solar maintenance. There is no regular bus service to the general area and project-related construction and operations and maintenance phases would not impact mass transit. The proposed project would not interfere with bicycle facilities because the proposed project is located in a rural portion of the County with no existing or potential future designated bike routes in the area. Therefore, the proposed project would not result in any significant impacts to any roadway segments or transportation related facilities/infrastructure within the project area during construction and operation; and would not conflict with a program plan, ordinance, or policy as it relates to traffic and transportation. Impacts are considered less than significant.

Mitigation Measure(s)

No mitigation measures are required.

Impact 3.13-2 Would the project conflict with or be inconsistent with CEQA Guidelines section 15064.3, subdivision (b)?

Section 15064.3(b) of the CEQA Guidelines provides guidance on determining the significance of transportation impacts and focuses on the use of vehicle miles traveled (VMT), which is defined as the amount and distance of automobile travel associated with a project. The Natural Resources Agency (NRA) has adopted guidance to incorporate SB 743 into CEQA analysis. The NRA's Technical Advisory on Evaluating Transportation Impacts in CEQA (NRA 2018), includes screening thresholds for small projects. Absent substantial evidence indicating that a project would generate a potentially significant level of VMT, or inconsistency with a Sustainable Communities Strategy (SCS) or general plan, projects that generate or attract fewer than 110 trips per day generally may be assumed to cause a less-than-significant transportation impact.

Although the proposed project would increase VMT during the construction phase as a result of trips made by construction workers and transportation of construction material and equipment, these increases are temporary in nature and would cease once construction is complete. Upon operation, the proposed project would only require intermittent maintenance (including inspection, panel washing, and vegetation removal), which would result in nominal (less than 10) daily vehicle trips. Therefore, the proposed project would not conflict or be inconsistent with Section 15064.3(b) of the CEQA Guidelines and this impact is considered less than significant.

Mitigation Measure(s)

No mitigation measures are required.

Impact 3.13-3 Would the project substantially increase hazards due to a geometric design feature (e.g., sharp curves or dangerous intersections) or incompatible uses (e.g., farm equipment)?

The project is a solar infrastructure project that would occur on privately-owned land located in a rural area. To accommodate emergency access, PV panels would be spaced to maintain proper clearance. Internal access roads, up to 30-feet wide, would be constructed along the perimeter fence and solar panels to facilitate vehicle access and maneuverability for emergency unit vehicles. Access roads would be graded and compacted (native soils) as required for construction, operations, maintenance, and emergency vehicle access. Additionally, any proposed haul routes would be submitted to the County for approval prior to construction. Therefore, the project would not substantially increase hazards due to a geometric design feature (e.g., sharp curves or dangerous intersections) or incompatible uses (e.g., farm equipment). Impacts are considered less than significant.

Mitigation Measure(s)

No mitigation measures are required.

Impact 3.13-4 Would the project result in inadequate emergency access?

Vehicular access to the project site is currently provided via an existing driveway along SR-98. Under the proposed project, vehicular access for workers would continue to be provided via the existing driveway as the project would not require additional storage lanes or lengths along SR-98. Following discussions with the Imperial Irrigation District, it was determined heavy construction vehicles would cross the All-American Canal at Gordon Wells Road located approximately 20 miles east of the project site (Figure 3.13-1). Access for heavy construction vehicles to and from the project site requires crossing the All-American Canal, via two existing bridges (Figure 3.13-2), located along Gordon Wells Road. Gordon Wells Road has an interchange with I-8. The bridges over the canal were constructed in 2009. The bridges are rated as open with no restrictions and have a “Good” condition rating.

As previously stated, PV panels would be spaced to maintain proper clearance for emergency access. Internal access roads, up to 30-feet wide, would be constructed along the perimeter fence and solar panels to facilitate vehicle access and maneuverability for emergency unit vehicles. Access roads would be graded and compacted (native soils) as required for construction, operations, maintenance, and emergency vehicle access. The access and service roads would also have turnaround areas at any dead-end to allow clearance for fire trucks per fire department standards. The access and service roads would also have turnaround areas at any dead-end to allow clearance for fire trucks per fire department standards. Therefore, the project would not result in inadequate emergency access and impacts are considered less than significant.

Mitigation Measure(s)

No mitigation measures are required.

3.13.4 Decommissioning/Restoration and Residual Impacts

Decommissioning/Restoration

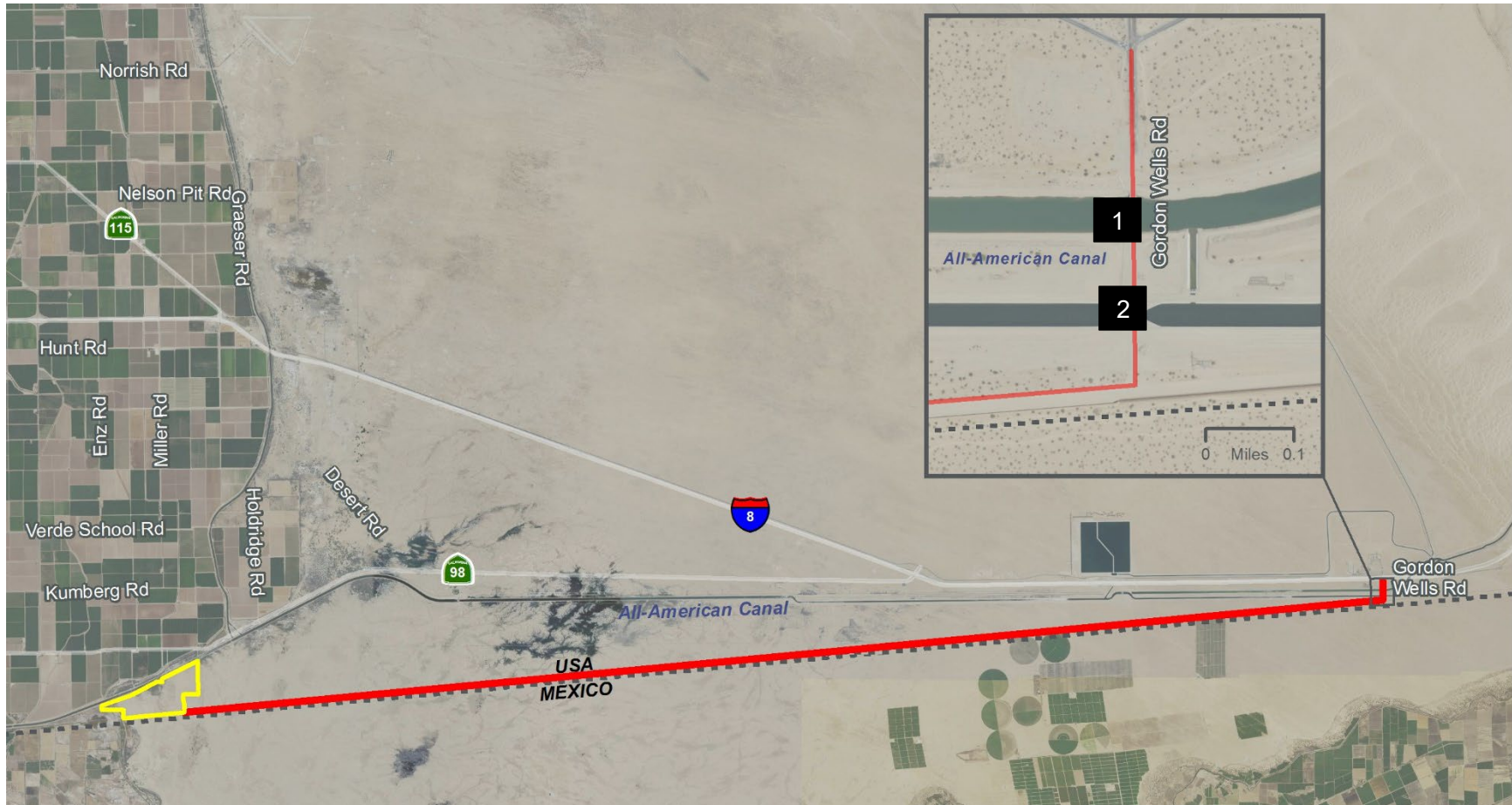
This section included an analysis of construction traffic for the proposed project. As presented above, construction traffic would not result in a significant impact on any of the project area roadway segments, intersections, and freeway segments because of the low volume of traffic. A similar scenario would occur during the decommissioning and site restoration stage for the proposed project. ADT would be similar to or less than the ADT required for construction. Similarly, the decommissioning activities would not result in a significant impact related to possible safety hazards, or possible conflicts with adopted policies, plans, or programs as the decommissioning and subsequent restoration would revert the project site to pre-project conditions. Therefore, decommissioning and restoration of the project site would not generate traffic resulting in a significant impact on the circulation network. A less than significant impact is identified, and no mitigation is required.

Residual



The construction and operation of the proposed project would not result in direct impacts on intersections, roadway segments, and freeway segments. Therefore, less than significant impacts have been identified. No mitigation is required, and no residual unmitigated impacts would occur with implementation of the proposed project.

This page is intentionally blank.

Figure 3.13-1. Proposed Heavy Construction Equipment Access



Legend

-  Proposed Heavy Construction Equipment Access
-  Project Location
-  # Bridge Crossing Locations – see Figure 3.13-2 for photos



This page is intentionally blank.

Figure 3.13-2. Proposed Bridge Crossings over All-American Canal



Bridge over north American Canal



Bridge over south American Canal

This page is intentionally blank.

3.14 Tribal Cultural Resources

This section discusses tribal cultural resources that may be potentially impacted by the proposed project. The following identifies if there are any existing tribal cultural resources within the project site, analyzes potential impacts of the proposed project, and recommends mitigation measures to avoid or reduce potential impacts of the proposed project. Information for this section is summarized from the Cultural Resources Inventory prepared by ECORP Consulting, Inc. This report is included in Appendix F of this EIR.

3.14.1 Existing Conditions

Tribal Cultural Setting

See Section 3.6, Cultural Resources of this EIR, for description of the regional ethnohistory.

Records Search

A records search from the SCIC of the CHRIS at San Diego State University was requested on September 15, 2020, to determine the extent of previous surveys within a 1-mile of the project area, and whether previously documented pre-contact or historic-period archaeological sites, architectural resources, or traditional cultural properties exist within the area.

As discussed in Section 3.6, Cultural Resources, because previous surveys took place more than 19 years ago, a resurvey of the project area was conducted and found 6 previously recorded cultural resources within 1-mile of the project area. Previously recorded resources comprise two historic-period canals, one historic-period bridge, one international boundary monument, one multicomponent precontact ceramic scatter/historic-period refuse deposit, and one pre-contact temporary camp with habitation debris. One previously recorded resource, an historic-period refuse deposit, is located within the project area.

Sacred Lands File Results

The California Native American Heritage Commission (NAHC) identifies, catalogs, and protects Native American cultural resources on private and public lands in California. Cultural resources include graves, cemeteries, and places of special religious or social significance to Native Americans. The NAHC also records the historical territories of state recognized tribes into a database called the Sacred Lands File. A records search of the Sacred Lands File is conducted to ensure that the tribes potentially affected by a project are properly notified and consulted.

A Sacred Land Files (SLF) search request was submitted on September 15, 2020, to the California NAHC and the search results were received on September 29, 2020. The search of the SLF was negative and failed to indicate the presence of Native American cultural resources in the project area.

3.14.2 Regulatory Setting

This section identifies and summarizes federal, state, and local laws, policies, and regulations that are applicable to the project.

Federal

Native American Graves Protection and Repatriation Act (1990); Title 25, United States Code Section 3001, et seq.

The Native American Graves Protection and Repatriation Act defines “cultural items,” “sacred objects,” and “objects of cultural patrimony;” establishes an ownership hierarchy; provides for review; allows excavation of human remains but stipulates return of the remains according to ownership; sets penalties; calls for inventories; and provides for the return of specified cultural items.

State

Assembly Bill 52

AB 52 amends PRC 5097.94 and adds eight new sections to the PRC relating to Native Americans. AB 52 was passed in 2014 and took effect on July 1, 2015. It establishes a new category of environmental impacts that must be considered under CEQA called tribal cultural resources (PRC 21074) and establishes a process for consulting with Native American tribes and groups regarding potential impacts to tribal resources. Under AB 52, a project that may substantially change the significance of a tribal cultural resource is a project that may have a significant impact on the environment. If a project may cause a significant impact on a tribal cultural resource, the lead agency shall implement measures to avoid the impacts when feasible.

Assembly Bill 2641

AB 2641 requires that upon discover of Native American remains, reasonable protection measures should be taken to protect the discovery from disturbance and the NAHC-designated Most Likely Descendent (MLD) shall be identified. The MLD shall be granted access to the site and given 48 hours to conduct a site inspection and make treatment recommendations. The concerned parties may extend discussions beyond the initial 48 hours to allow for the discovery of additional remains. AB 2641(e) includes a list of site protection measures and states that the landowner shall comply with one or more of the following:

- (1) Record the site with the NAHC or the appropriate Information Center.
- (2) Utilize an open-space or conservation zoning designation or easement.
- (3) Record a document with the county in which the property is located.

Assembly Bill 4239

AB 4239, passed in 1976, established the NAHC as the primary government agency responsible for identifying and cataloging Native American cultural resources. The bill authorized the Commission to act in order to prevent damage to and insure Native American access to sacred sites and authorized the Commission to prepare an inventory of Native American sacred sites located on public lands.

Public Resources Code Section 21074

PRC Section 21074 defines a tribal cultural resource as a site, feature, place, cultural landscape, sacred place, and any object with cultural value to a California Native American Tribe. A tribal cultural resource must be on or eligible for the CRHR or must be included in a local register of historical resources. The lead agency can determine if a tribal cultural resource is significant even if it has not been evaluated for the CRHR or is not included on a local register.

Public Resources Code 5097.97

No public agency and no private party using or occupying public property or operating on public property under a public license, permit, grant, lease, or contract made on or after July 1, 1977, shall in any manner whatsoever interfere with the free expression or exercise of Native American religion as provided in the U.S. Constitution and the California Constitution; nor shall any such agency or party cause severe or irreparable damage to any Native American sanctified cemetery, place of worship, religious or ceremonial site, or sacred shrine located on public property, except on a clear and convincing showing that the public interest and necessity so require.

Public Resources Code 5097.98 (b) and (e)

As amended by AB 2641, PRC 5097.98 (b) and (e) require a landowner on whose property Native American human remains are found to limit further development activity in the vicinity until he/she confers with the NAHC-identified most likely descendants (MLD) to consider treatment options. In the absence of MLDs or of a treatment acceptable to all parties, the landowner is required to reenter the remains elsewhere on the property in a location not subject to further disturbance.

California Health and Safety Code, Section 7050.5

California HSC 7050.5 makes it a misdemeanor to disturb or remove human remains found outside a cemetery. This code also requires a project owner to halt construction if human remains are discovered and to contact the County Coroner.

Local

Imperial County General Plan

The Imperial County General Plan provides goals, objectives, and policies for the identification and protection of significant cultural resources. The Conservation and Open Space Element of the General Plan includes goals, objectives, and policies for the protection of cultural resources and scientific sites that emphasize identification, documentation, and protection of cultural resources. While Section 3.11, Land Use Planning, of this EIR analyzes the proposed project's consistency with the General Plan pursuant to CEQA Guidelines Section 15125(d), the Imperial County Board of Supervisors and Planning Commission ultimately make a determination as to the project's consistency with the General Plan. Goals and Objectives applicable to the proposed project are summarized in Table 3.14-1.

Table 3.14-1. Project Consistency with Applicable General Plan Goals and Objectives

General Plan Policies	Consistency with General Plan	Analysis
<p>Conservation and Open Space Element - Open Space and Recreation Conservation</p> <p>Goal 1 - Environmental resources shall be conserved for future generations by minimizing environmental impacts in all land use decisions and educating the public on their value.</p> <p>Objective 1.4 - Ensure the conservation and management of the County's natural and cultural resources.</p>	Consistent	<p>A Cultural Resources Inventory was prepared for the proposed project. Based on the SLF search, there are no known tribal cultural resources within the project area. However, as discussed below, the proposed project has the potential to encounter undocumented tribal cultural resources and Native American human remains.</p> <p>Implementation of Mitigation Measures CR-2 and CR-3 would reduce potentially significant impacts on unknown historic or unique archaeological materials during construction of the project site. Implementation of Mitigation Measure CR-4 would reduce potential impacts on human remains to a level less than significant.</p>
<p>Objective 3.1 - Protect and preserve sites of archaeological, ecological, historical, and scientific value, and/or cultural significance.</p>	Consistent	

Source: County of Imperial 1993; Appendix F of this EIR

Notes:

CR=cultural resource

3.14.3 Impacts and Mitigation Measures

This section presents the significance criteria used for considering project impacts related to tribal cultural resources, the methodology employed for the evaluation, an impact evaluation, and mitigation requirements, if necessary.

Thresholds of Significance

Based on CEQA Guidelines Appendix G, project impacts related to tribal cultural resources are considered significant if the project causes a substantial adverse change in the significance of a tribal cultural resource defined in PRC section 21074 as either a site, feature, place, cultural landscape that is geographically defined in terms of the size and scope of the landscape, sacred place, or object with cultural value to a California Native American tribe, and that is:

- Listed or eligible for listing in the CRHR, or in a local register of historical resources as defined in PRC section 5020.1(k)
- A resource determined by the lead agency, in its discretion and supported by substantial evidence, to be significant pursuant to criteria set forth in subdivision (c) of PRC Section 5024.1. In applying the criteria set forth in subdivision (c) of PRC Section 5024.1, the lead agency shall consider the significance of the resource to a California Native American tribe

Methodology

This analysis evaluates the potential for the proposed project, as described in Chapter 2, Project Description, to interact with tribal cultural resources in the project site. Based on the extent of these interactions, this analysis considers whether these conditions would result in an exceedance of one or more of the applied significance criteria as identified above.

As indicated in the environmental setting, a Cultural Resources Inventory (Appendix F of this EIR) was prepared for the proposed project. The cultural resources inventory provides the results of a SCIC records search, a SLF search conducted by the NAHC, and field survey, which have been completed for the project site pursuant to CEQA.

This report is included in Appendix F of this EIR. The information from the cultural resources inventory was reviewed and summarized to present the existing conditions and to identify potential environmental impacts, based on the significance criteria presented in this section. Impacts associated with tribal cultural resources that could result from project construction and operational activities were evaluated qualitatively based on site conditions; expected construction practices; materials, locations, and duration of project construction and related activities.

Impact Analysis

Impact 3.14-1 *Would the project cause a substantial adverse change in the significance of a tribal cultural resource defined in Public Resources Code section 21074 as either a site, feature, place, cultural landscape that is geographically defined in terms of the size and scope of the landscape, sacred place, or object with cultural value to a California Native American tribe, and that is:*

Listed or eligible for listing in the California Register of Historical Resources, or in a local register of historical resources as defined in Public Resources Code section 5020.1(k)

A resource determined by the lead agency, in its discretion and supported by substantial evidence, to be significant pursuant to criteria set forth in subdivision (c) of Public Resources Code Section 5024.1. In applying the criteria set forth in subdivision (c) of Public Resources Code Section 5024.1, the lead agency shall consider the significance of the resource to a California Native American tribe?

The NAHC maintains the confidential SLF which contains sites of traditional, cultural, or religious value to the Native American community. A SLF search request was submitted on September 15, 2020 to the California NAHC and the search results were received on September 29, 2020. The search of the SLF was negative and failed to indicate the presence of Native American cultural resources in the project area. AB 52 requires a lead agency to begin consultation with a California Native American Tribe that is traditionally and culturally affiliated with the geographic areas of the proposed project. In accordance with AB 52, the County provided notification of the proposed project to Native American tribes that the County understands to be traditionally and culturally affiliated with the geographic area of the proposed project. This notification was provided in a letter sent via certified mail on March 26, 2021 to the Quechan Indian Tribe. On April 1, 2021, the Quechan Indian Tribe requested consultation with the County on the proposed project. The County is in the process of consulting with the Quechan Indian Tribe and has requested that they provide any information regarding any Traditional Cultural Properties, Sacred Sites, resource collecting areas, or any other areas of concern known to occur in the project area.

To date, no tribes have indicated the potential for traditional cultural properties or sacred sites. Therefore, the project is not anticipated to cause a substantial adverse change in the significance of a tribal cultural resource, defined in PRC section 21074 as either a site, feature, place, cultural landscape that is geographically defined in terms of the size and scope of the landscape, sacred place, or object with cultural value to a California Native American tribe, and that is a resource determined by the lead agency, in its discretion and supported by substantial evidence, to be significant pursuant to criteria set forth in subdivision (c) of PRC Section 5024.1, and, per the criteria set forth in Section 5024.1, considering the significance of the resource to a California Native American tribe. As stated in Section 3.6 Cultural Resources, potential impacts to archaeological resources would be less than significant with implementation of Mitigation Measure CR-2. Impacts specifically related to tribal cultural resources would be less than significant.

Mitigation Measure(s)

No mitigation measures are required.

3.14.4 Decommissioning/Restoration and Residual Impacts

Decommissioning/Restoration

If at the end of the PPA term, no contract extension is available for a power purchaser, no other buyer of the energy emerges, or there is no further funding of the project, the project will be decommissioned and dismantled. No impact is anticipated from restoration activities as the ground disturbance and associated impacts on tribal cultural resources will have occurred during the construction phase of the proposed project.

Residual

No unmitigable impacts on cultural resources would occur with implementation of the proposed project.

3.15 Utilities and Service Systems

This section includes an evaluation of potential impacts for identified Utilities/Service Systems that could result from implementation of the project. Utilities/Service Systems include wastewater treatment facilities, stormwater drainage facilities, water supply and treatment, and solid waste disposal. The impact analysis provides an evaluation of potential impacts to Utilities/Service Systems based on criteria derived from CEQA Guidelines in conjunction with actions proposed in Chapter 2, Project Description. A *Water Supply Assessment* (WSA) was prepared for the VEGA SES 4 Solar Energy Project. This report is included in Appendix L of this EIR.

The IS/NOP prepared for this EIR determined that impacts with regards to solid waste disposal, storm drainage, and wastewater treatment would be less than significant. Therefore, these impacts are not addressed in detail in this EIR; however, the rationale for eliminating these issues is discussed in Chapter 6.0, Effects Found Not Significant.

3.15.1 Existing Conditions

The Imperial Valley area is located within the south-central part of Imperial County and is bound by Mexico on the south, the Algodones Sand Hills on the east, the Salton Sea on the north and San Diego County on the northwest, and the alluvial fans bordering the Coyote Mountains and the Yuha Desert to the southwest. Imperial Valley depends on the Colorado River for its water, which the Imperial Irrigation District (IID) transports, untreated, to delivery gates for agricultural, municipal, industrial (including geothermal and solar energy), environmental (managed marsh), recreational (lakes), and other non-agricultural uses. IID supplies the cities, communities, institutions and Golden State Water (which includes all or portions Calipatria, Niland, and some adjacent Imperial County territory) with untreated water that they treat to meet state and federal drinking water guidelines before distribution to their customers (Appendix L of this EIR).

Although the project site is currently vacant land and does not currently receive water from IID, the project site is located within IID's Imperial Unit and district boundary and as such is eligible to receive water service. IID has adopted an Interim Water Supply Policy (IWSP) for Non-Agricultural Projects, from which water supplies can be contracted to serve new developments within IID's water service area. The IWSP sets aside 25,000 acre-feet annually (AFY) of IID's Colorado River water supply to serve new non-agricultural projects. As of April 2021, a balance of 23,800 acre-feet per year (AFY) remain available under the IWSP for new non-agricultural projects ensuring reasonably sufficient supplies for such projects (Appendix L of this EIR).

3.15.2 Regulatory Setting

This section identifies and summarizes laws, policies, and regulations that are applicable to the proposed project.

State

Senate Bill 610

With the introduction of SB 610, any project under CEQA shall provide a WSA if:

- The project meets the definition of the Water Code Section 10912:

For the purposes of this part, the following terms have the following meanings:

(a) “Project” means any of the following:

- (1) A proposed residential development of more than 500 dwelling units.
- (2) A proposed shopping center or business establishment employing more than 1,000 persons or having more than 500,000 square feet of floor space.
- (3) A proposed commercial office building employing more than 1,000 persons or having more than 250,000 square feet of floor space.
- (4) A proposed hotel or motel, or both, having more than 500 rooms.
- (5) A proposed industrial, manufacturing, or processing plant, or industrial park planned to house more than 1,000 persons, occupying more than 40 acres of land, or having more than 650,000 square feet of floor area.
- (6) A mixed-use project that includes one or more of the projects specified in this subdivision.
- (7) A project that would demand an amount of water equivalent to, or greater than, the amount of water required by a 500 dwelling unit project.

(b) If a public water system has fewer than 5,000 service connections, then “project” means any proposed residential, business, commercial, hotel or motel, or industrial development that would account for an increase of 10 percent or more in the number of the public water system’s existing service connections, or a mixed-use project that would demand an amount of water equivalent to, or greater than, the amount of water required by residential development that would represent an increase of 10 percent or more in the number of the public water system’s existing service connections.

After review of Water Code Section 10912, the solar facility is deemed a “project” because it is a proposed industrial use occupying more than 40 acres of land.

California Water Code

Water Code Sections 10656 and 10657 restrict state funding for agencies that fail to submit their urban water management plan to the Department of Water Resources. In addition, Water Code Section 10910 describes the WSA that must be undertaken for projects referred under PRC Section 21151.9, including an analysis of groundwater supplies. Water agencies are given 90 days from the start of consultation in which to provide a WSA to the CEQA lead agency. Water Code Section 10910 also specifies the circumstances under which a project for which a WSA was once prepared would be required to obtain another assessment. Water Code Section 10631 directs that contents of the urban water management plans include further information on future water supply projects and programs and groundwater supplies.

Water Quality Control Plan for the Colorado River Basin

The Water Quality Control Plan for the Colorado River Basin (or Basin Plan) prepared by the Colorado River RWQCB (Region 7) identifies beneficial uses of surface waters within the Colorado River Basin region, establishes quantitative and qualitative water quality objectives for protection of beneficial uses, and establishes policies to guide the implementation of these water quality objectives.

Local

Imperial Integrated Regional Water Management Plan

The Imperial Integrated Regional Water Management Plan (IRWMP) serves as the governing document for regional water planning to meet present and future water resource needs and demands by addressing such issues as additional water supply options, demand management and determination and prioritization of uses and classes of service provided. In November 2012, the Imperial County Board of Supervisors approved the Imperial IRWMP, and the City of Imperial City Council and the IID Board of Directors approved it in December 2012. Through the IRWMP process, IID presented to the region stakeholders options in the event long-term water supply augmentation is needed, such as water storage and banking, recycling of municipal wastewater, and desalination of brackish water.

Imperial Irrigation District Interim Water Supply Policy for Non-Agricultural Projects

The IWSP was adopted by the IID Board on September 29, 2009. The IWSP provides a mechanism to address water supply requests for projects being developed within the IID service area. The IWSP designates up to 25,000 AFY of IID's annual Colorado River water supply for new non-agricultural projects, provides a mechanism and process to develop a water supply agreement for any appropriately permitted project, and establishes a framework and set of fees to ensure the supplies used to meet new demands do not adversely affect existing users by funding water conservation or augmentation projects, as needed.

Depending on the nature, complexity, and water demands of the proposed project, new projects may be charged a one-time reservation fee and an annual water supply development fee for the contracted water volume used solely to assist in funding new water supply projects. All new industrial use projects are subject to the fee, while new municipal and mixed-use projects shall be subject to the fee if the project water demands exceed certain district-wide average per capita use standards. The applicability of the fee to mixed-use projects will be determined by IID on a case-by-case basis, depending on the proportion of types of land uses and water demand proposed for a project.

Temporary Land Conversion Following Policy

The Temporary Land Conversion Following Policy was adopted by the Board on October 28, 2013, to provide a mechanism for IID to administer apportionment of the district's quantified annual supply of Colorado River water; IID board approved a resolution repealing the Equitable Distribution Plan (EDP) on February 6, 2018.

In order to facilitate new development and economic diversity in Imperial County; as well as ensure that the long-term, temporary, land use designations are conducive to a coordinated land use/water supply policy as envisioned in the Imperial IRWMP the IID Temporary Land Conversion Following Policy was developed. This policy provides a framework for a temporary, long-term following program to work in concert with the IWSP and provides direction for certain private projects that, if implemented, will temporarily remove land from agricultural production within the district's water service area include renewable solar energy and other non-agricultural projects. Such projects may need a short-term water supply for construction and decommissioning activities and longer-term water service for facility operation and maintenance or for treating to potable water standards.

3.15.3 Impacts and Mitigation Measures

Thresholds of Significance

Based on CEQA Guidelines Appendix G, project impacts related to utilities and service systems are considered significant if any of the following occur:

Water Supply

- Have insufficient water supplies available to serve the project and reasonably foreseeable future development during normal, dry and multiple dry years

Methodology

The WSA (Appendix L of this EIR) was prepared using project-specific data to calculate the project's water consumption during construction and at build-out collectively ("operational").

Impact Analysis

Impact 3.15-1 Have sufficient water supplies available to serve the project and reasonably foreseeable future development during normal, dry and multiple dry years?

CONSTRUCTION

Water for construction would be obtained from IID canals or laterals in conformance with IID rules and regulations for municipal, commercial, and industrial (MCI) temporary water use. Water would be picked up from the All-American Canal and delivered to the construction location by a water truck capable of carrying approximately 4,000 gallons per load.

The proposed project is anticipated to take approximately 18 months from the commencement of the construction process to complete. Construction water needs would be limited to earthwork, soil conditioning, dust suppression, and compaction efforts. The proposed project would require approximately 183.3 AFY of water during construction.

OPERATIONS AND MAINTENANCE

The estimated annual water consumption for operation and maintenance of the proposed project, including periodic PV module washing, would be approximately 10 AFY, which would be trucked to the project site as needed. No full-time site personnel would be required on-site during operations and approximately two employees would only be onsite up to four times per year to wash the solar panels to ensure optimum solar absorption by removing dust particles and other buildup.

TOTAL AND ANNUAL WATER DEMAND

According to the WSA (Appendix L of this EIR), the anticipated water demand for construction and operation project is estimated to be 460 AF, for an annualized demand of 23 AFY for the 20-year project life.

WATER SUPPLY

Water for the project site will be supplied through an IWSP Water Supply Agreement with IID to process the untreated Colorado River water for the proposed project. The IWSP sets aside 25,000 AFY of IID's Colorado River water supply to serve new non-agricultural projects. As of April 2021, a

balance of 23,800 AFY remain available under the IWSP for new non-agricultural projects ensuring reasonably sufficient supplies for such projects. The proposed project has an estimated total water demand of 460 AF or 23 AFY amortized over a 20-year term (to be pumped to water trucks directly from the All-American Canal – there would be no diversion through any delivery gates for project). Thus, the proposed project demand is an increase of 23 AFY from the historical 10-year average. There has been no prior delivery for agricultural uses at the project site. The project's water demand of approximately 23 AFY amortized over 20 years represents 0.1 percent of the unallocated supply set aside in the IWSP for non-agricultural projects, and approximately 0.01 percent of forecasted future non-agricultural water demands planned in the Imperial IRWMP through 2055. Therefore, the amount of water available and the stability of the IID water supply along with on-farm and system efficiency conservation and other measures being undertaken by IID and its customers ensures that the project's needs will be met for the next 20 years as assessed for compliance under SB-610. Therefore, the proposed project would have sufficient water supplies available to serve the project from existing entitlements and resources, and impacts would be less than significant.

Mitigation Measure(s)

No mitigation measures are required.

3.15.4 Decommissioning/Restoration and Residual Impacts

Decommissioning/Restoration

If at the end of the PPA term, no contract extension is available for a power purchaser, no other buyer of the energy emerges, or there is no further funding of the project, the project will be decommissioned and dismantled. It is anticipated that a small quantity of water would be required during decommissioning of the project and site restoration. This water need would be less than what is required for construction and operation of the project site. Therefore, a less than significant impact is identified and no mitigation is required.

Residual

The proposed project would not result in significant impacts on the water supply of Imperial County; therefore, no mitigation is required. The proposed project will not result in residual impacts.

This page is intentionally blank.

4 Analysis of Long-Term Effects

4.1 Growth-Inducing Impacts

In accordance with Section 15126.2(d) of CEQA Guidelines, an EIR must:

“discuss the ways in which the proposed project could foster economic or population growth, or the construction of additional housing, either directly or indirectly, in the surrounding environment. Included in this are projects which would remove obstacles to population growth ... Increases in the population may tax existing community service facilities, requiring construction of new facilities that could cause significant environmental effects. Also discuss the characteristics of some projects which may encourage and facilitate other activities that could significantly affect the environment, either individually or cumulatively. It must not be assumed that growth in any area is necessarily beneficial, detrimental, or of little significance to the environment.”

Projects promoting direct growth will impose burdens on a community by directly inducing an increase in population or resulting in the construction of additional developments in the same area. For example, projects involving the expansion, modifications, or additions to infrastructure, such as sewer, water, and roads, could have the potential to directly promote growth by removing existing physical barriers or allowing for additional development through capacity increases. New roadways leading into a previously undeveloped area directly promote growth by removing previously existing physical barriers to development and a new wastewater treatment plant would allow for further development within a community by increasing infrastructure capacity. Because these types of infrastructure projects directly serve related projects and result in an overall impact to the local community, associated impacts cannot be considered isolated. Indirect growth typically includes substantial new permanent employment opportunities and can result from these aforementioned modifications.

The proposed project is located within the unincorporated area of Imperial County, and it does not involve the development of permanent residences that would directly result in population growth in the area. The unemployment rate in Imperial County, as of September 2022, was 16.0 percent (State of California Employment Development Department 2022). The applicant expects to utilize construction workers from the local and regional area, a workforce similar to that involved in the development of other utility-scale solar facilities. Based on the unemployment rate, and the availability of the local workforce, construction of the proposed project would not have a growth-inducing effect related to workers moving into the area and increasing the demand for housing and services.

Once construction is completed, the facility would be remotely operated, controlled and monitored and with no requirement for daily on-site employees. Security personnel may conduct unscheduled security rounds and would be dispatched to the project site in response to a fence breach or other alarm. It is anticipated that maintenance of the facilities would require minimal site presence to perform periodic visual inspections and minor repairs. On intermittent occasions, the presence of additional workers may be required for repairs or replacement of equipment and panel cleaning; however, because of the nature of the facility, such actions would likely occur infrequently. Overall, minimal maintenance requirements are anticipated. The proposed project would not result in substantial population growth, as the number of employees required to operate and maintain the facility is minimal.

While the proposed project would contribute to energy supply, which indirectly supports population growth, the proposed project is a response to the state’s need for renewable energy to meet its

Renewable Portfolio Standard, and while it would increase the availability of renewable energy, it would also replace existing sources of non-renewable energy. Unlike a gas-fired power plant, the proposed project is not being developed as a source of base-load power in response to growth in demand for electricity. The power generated would be added to the state's electricity grid with the intent that it would displace fossil fueled power plants and their associated environmental impacts, consistent with the findings and declarations in SB 100 that a benefit of the Renewable Portfolio Standard is displacing fossil fuel consumption within the state. The project is being proposed in response to state policy and legislation promoting development of renewable energy.

The proposed project would supply energy to accommodate and support existing demand and projected growth, but the energy provided by the project would not foster any new growth because (1) the additional energy would be used to ease the burdens of meeting existing statewide energy demands within and beyond the area of the project site; (2) the energy would be used to support already-projected growth; or, (3) the factors affecting growth are so diverse that any potential connection between additional energy production and growth would necessarily be too speculative and uncertain to merit further analysis.

Under CEQA, an EIR should consider potentially significant energy implications of a project (CEQA Guidelines Appendix F(II); PRC Section 21100(b)(3)). However, the relationship between the proposed project's increased electrical capacity and the growth-inducing impacts outside the surrounding area is too speculative and uncertain to warrant further analysis. When a project's growth-inducing impacts are speculative, the lead agency should consider 14 CCR §15145, which provides that, if an impact is too speculative for evaluation, the agency should note this conclusion and terminate discussion of the impact. As the court explained in *Napa Citizens for Honest Gov't v. Napa County Board of Supervisors*, 91 Cal. App.4th 342, 368: "Nothing in the Guidelines, or in the cases, requires more than a general analysis of projected growth" *Napa Citizens*, 91 CA4th at 369. The problem of uncertainty of the proposed project's growth-inducing effects cannot be resolved by collection of further data because of the diversity of factors affecting growth.

While this document has considered that the proposed project, as an energy project, might foster regional growth, the particular growth that could be attributed to the proposed project is unpredictable, given the multitude of variables at play, including uncertainty about the nature, extent, and location of growth and the effect of other contributors to growth besides the proposed project. No accurate and reliable data is available that could be used to predict the amount of growth outside the area that would result from the proposed project's contribution of additional electrical capacity. The County of Imperial has not adopted a threshold of significance for determining when an energy project is growth-inducing. Further evaluation of this impact is not required under CEQA.

Additionally, the project would not involve the development of any new roadways, new water systems, or sewer; and thus, the project would not further facilitate additional development into outlying areas. For these reasons, the proposed project would not be growth-inducing.

4.2 Significant Irreversible Environmental Changes

In accordance with CEQA Guidelines Section 15126.2(c), an EIR must identify any significant irreversible environmental changes that would be caused by implementation of the proposed project being analyzed. Irreversible environmental changes may include current or future commitments to the use of non-renewable resources or secondary growth-inducing impacts that commit future generations to similar uses.

Energy resources needed for the construction of the proposed project would contribute to the incremental depletion of renewable and non-renewable resources. Resources, such as timber, used in building construction are generally considered renewable and would ultimately be replenished. Non-renewable resources, such as petrochemical construction materials, steel, copper, lead and other metals, gravel, concrete, and other materials, are typically considered finite and would not be replenished over the lifetime of the project. Thus, the project would irretrievably commit resources over the anticipated 30-year life of the project.

At the end of the project's operation term, the applicant may determine that the project should be decommissioned and deconstructed. Should the project be decommissioned, the project applicant is required to restore land to its pre-project state. Consequently, some of the resources on the site could potentially be retrieved after the site has been decommissioned. Concrete footings, foundations, and pads would be removed and recycled at an off-site location. All remaining components would be removed, and all disturbed areas would be reclaimed and recontoured. The applicant anticipates using the best available recycling measures at the time of decommissioning.

Implementation and operation of the proposed project would promote the use of renewable energy and contribute incrementally to the reduction in demand for fossil fuel use for electricity-generating purposes. Therefore, the incremental reduction in fossil fuels would be a positive effect of the commitment of nonrenewable resources. Additionally, the project is consistent with the state's definition of an "eligible renewable energy resource" in Section 399.12 of the California Public Utilities Code and the definition of "in-state renewable electricity generation facility" in Section 25741 of the California PRC.

4.3 Unavoidable Adverse Impacts

In accordance with CEQA Guidelines Section 15126(b), EIRs must include a discussion of significant environmental effects that cannot be avoided if the proposed project is implemented. The impact analysis, as detailed in Section 3 of this EIR, concludes that no unavoidable significant impacts were identified. Where significant impacts have been identified, mitigation measures are proposed, that when implemented, would reduce the impact level to less than significant.

This page is intentionally blank.

5 Cumulative Impacts

The CEQA Guidelines (Section 15355) define a cumulative impact as “two or more individual effects which, when considered together, are considerable or which compound or increase other environmental impacts.” The CEQA Guidelines [Section 15130(a)(1)] further states that “an EIR should not discuss impacts which do not result in part from the project.”

Section 15130(a) of the CEQA Guidelines provides that “[A]n EIR shall discuss cumulative impacts of a project when the project’s incremental effect is cumulatively considerable...” Cumulatively considerable, as defined in Section 15065(a)(3), “means that the incremental effects of an individual project are significant when viewed in connection with the effects of past projects, the effects of other current projects, and the effects of probable future projects.”

An adequate discussion of significant cumulative impacts requires either: (1) “a list of past, present, and probable future projects producing related or cumulative impacts, including, if necessary, those projects outside the control of the agency; or (2) “a summary of projections contained in an adopted general plan or related planning document, or in a prior environmental document which has been adopted or certified, which described or evaluated regional or area-wide conditions contributing to the cumulative impact.”

The CEQA Guidelines recognize that cumulative impacts may require mitigation, such as new rules and regulations that go beyond project-by-project measures. An EIR may also determine that a project’s contribution to a significant cumulative impact will be rendered less than cumulatively considerable and thus is not significant. A project’s contribution is less than cumulatively considerable if the project is required to implement or fund its fair share of a mitigation measure or measures designed to alleviate the cumulative impact. The Lead Agency must identify facts and analysis supporting its conclusion that the contribution will be rendered less than cumulatively considerable (CEQA Guidelines Section 15130(a)(3)).

This EIR evaluates the cumulative impacts of the project for each resource area, using the following steps:

1. Define the geographic and temporal scope of cumulative impact analysis for each cumulative effects issue, based on the project’s reasonably foreseeable direct and indirect effects.
2. Evaluate the cumulative effects of the project in combination with past and present (existing) and reasonably foreseeable future projects and, in the larger context of the Imperial Valley.
3. Evaluate the project’s incremental contribution to the cumulative effects on each resource considered in Chapter 3, Environmental Analysis. When the project’s incremental contribution to a significant cumulative impact is considerable, mitigation measures to reduce the project’s “fair share” contribution to the cumulative effect are discussed, where required.

5.1 Geographic Scope and Timeframe of the Cumulative Effects Analysis

The geographic area of cumulative effects varies by each resource area considered in Chapter 3. For example, air quality impacts tend to disperse over a large area, while traffic impacts are typically more

localized. Similarly, impacts on the habitats of special-status wildlife species need to be considered within its range of movement and associated habitat needs.

The analysis of cumulative effects in this EIR considers a number of variables including geographic (spatial) limits, time (temporal) limits, and the characteristics of the resource being evaluated. The geographic scope of each analysis is based on the topography surrounding the project site and the natural boundaries of the resource affected, rather than jurisdictional boundaries. The geographic scope of cumulative effects will often extend beyond the scope of the direct effects of a project, but not beyond the scope of the direct and indirect effects of that project.

The cumulative development scenario includes projects that extend through year (2030), which is the planning horizon of the County of Imperial General Plan. Because of uncertain development patterns that are far in the future, it is too speculative to accurately determine the type and quantity of cumulative projects beyond the planning horizon of the County's adopted County General Plan. Evaluating the proposed project's cumulative impacts when future facility decommissioning occurs is highly speculative because decommissioning is expected to occur in 20 to 25 years' time. Therefore, cumulative impacts during decommissioning are speculative for detailed consideration in this analysis.

5.2 Projects Contributing to Potential Cumulative Impacts

The CEQA Guidelines identify two basic methods for establishing the cumulative environment in which the projects are to be considered: the use of a list of past, present, and probable future projects (the "list approach") or the use of adopted projections from a general plan, other regional planning document, or certified EIR for such a planning document (the "plan approach").

For this EIR, the list approach has been utilized to generate the most reliable future projections of possible cumulative impacts. When the impacts of the project are considered in combination with other past, present, and future projects to identify cumulative impacts, the other projects considered may also vary depending on the type of environmental impacts being assessed. As described above, the general geographic area associated with different environmental impacts of the project defines the boundaries of the area used for compiling the list of projects considered in the cumulative impact analysis. Figure 5-1 provides the general location for each of these projects in relation to the project site.

5.3 Cumulative Impact Analysis

This cumulative impact analysis utilizes an expanded list method (as defined under CEQA) and considers environmental effects associated with those projects identified in Table 5-1 in conjunction with the impacts identified for the project in Chapter 3 of this EIR. Table 5-1 includes projects known at the time of release of the NOP of the Draft EIR, as well as additional projects that have been proposed since the NOP date. Figure 5-1 provides the general location for each of these projects in relation to the project site.



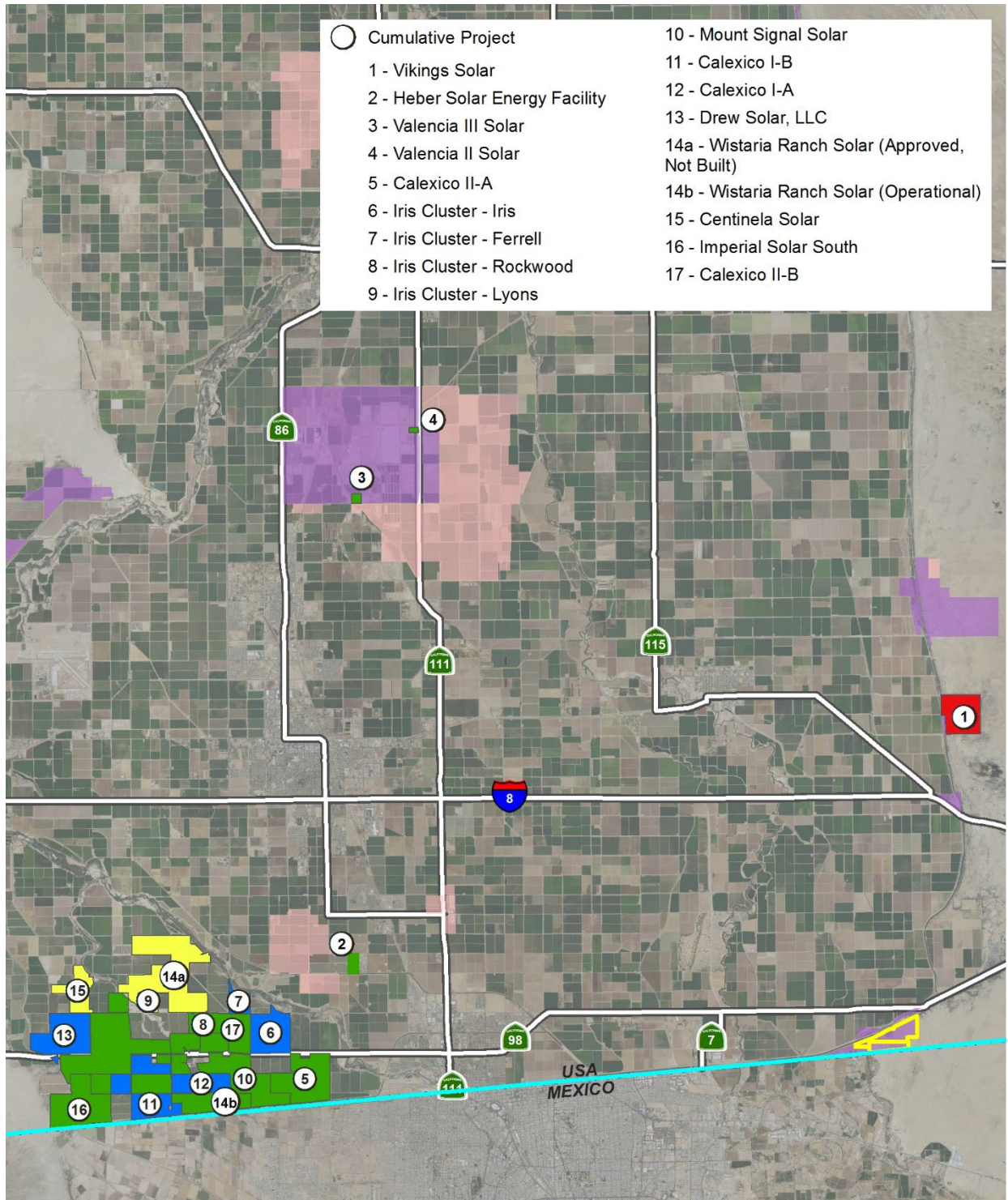
Table 5-1. Projects Considered in the Cumulative Impact Analysis

Map Label ¹	Project Name	Project Type	Distance from Project Site (miles)	Capacity (MW)	Status ²
1	Vikings Solar	PV Solar Facility	3.0	150	Pending Entitlement
2	Heber Solar Energy Facility	PV Solar Facility	5.1	14	Operational
3	Valencia III Solar	PV Solar Facility	7.1	3	Operational
4	Valencia II Solar	PV Solar Facility	7.2	3	Operational
5	Calexico II-A	PV Solar Facility	5.5	200	Operational
6	Iris Cluster – Iris Solar Facility	PV Solar Facility	5.8	130	Approved – Under Construction
7	Iris Cluster – Ferrell Solar Facility	PV Solar Facility	6.1	90	Approved – Under Construction
8	Iris Cluster - Rockwood	PV Solar Facility	6.4	100	Operational
9	Iris Cluster - Lyons	PV Solar Facility	6.9	40	Approved – Not Built
10	Mount Signal Solar	PV Solar Facility	6.4	800	Operational
11	Calexico I-B	PV Solar Facility	7.0	100	Approved – Under Construction
12	Calexico I-A	PV Solar Facility	6.6	100	Approved – Under Construction
13	Drew Solar	PV Solar Facility	7.7	100	Approved – Under Construction
14a	Wistaria Ranch Solar (Approved, Not Built)	PV Solar Facility	6.6	250	Approved – Not Built
14b	Wistaria Ranch Solar (Operational)	PV Solar Facility	6.8	250	Operational
15	Centinela Solar	PV Solar Facility	7.6	275	Approved – Not Built
16	Imperial Solar South	PV Solar Facility	7.6	130	Operational
17	Calexico II-B	PV Solar Facility	6.1	200	Operational

1 – See Figure 5-1 for cumulative project location.

2 – Project status based on information provided by County staff and on Imperial County Planning & Development Service’s RE Geographic Information System Mapping Application (<https://icpds.maps.arcgis.com/apps/webappviewer/index.html?id=0d869c18d11645cc918391fdcac24b80>). Accessed in November 2022.

Figure 5-1. Cumulative Projects



- | | |
|---------------------------------|--------------------------------------------------|
| ○ Cumulative Project | 10 - Mount Signal Solar |
| 1 - Vikings Solar | 11 - Calexico I-B |
| 2 - Heber Solar Energy Facility | 12 - Calexico I-A |
| 3 - Valencia III Solar | 13 - Drew Solar, LLC |
| 4 - Valencia II Solar | 14a - Wistaria Ranch Solar (Approved, Not Built) |
| 5 - Calexico II-A | 14b - Wistaria Ranch Solar (Operational) |
| 6 - Iris Cluster - Iris | 15 - Centinela Solar |
| 7 - Iris Cluster - Ferrell | 16 - Imperial Solar South |
| 8 - Iris Cluster - Rockwood | 17 - Calexico II-B |
| 9 - Iris Cluster - Lyons | |

Legend

VEGA SES 4 Project Parcels

Renewable Energy Overlay

Geothermal Only

Renewable Energy/Geothermal

Solar Projects

Approved - Not Built

Approved - Under Construction

Operational

Pending Entitlement



5.3.1 Aesthetics and Visual Resources

The cumulative study area for projects considered in the visual resources cumulative impact analysis considers a 5-mile radius from the project site. Views beyond 5 miles are obstructed by a combination of the flat topography coupled with the Earth's curvature. The short-term visual impacts of the project would be in the form of general construction activities including grading, use of construction machinery, and installation of the transmission poles and stringing of transmission lines, but would only be available to a very limited amount of people and would have to be in relative close proximity to the project site. Longer-term visual impacts of the project would be in the form of the presence of solar array grids, battery storage containers, an electrical distribution and transmission system, and substation.

As discussed in Section 3.2, Aesthetics and Visual Resources, visibility of the project site from the public right of way is obstructed from SR-98 by a berm. Surrounding property is privately owned and viewers would be limited to private property owners, employees servicing/maintaining IID facilities (e.g., the All-American Canal), and U.S. Border Patrol personnel.

The visual changes associated with the project would be located in a remote area viewed by a minimal number of people, the project site is not located within scenic vistas, and is not readily viewable from any frequently travelled interstates or scenic highways. Further, the project site would be restored to its existing condition following the decommissioning of the solar uses. As a result, although the visual character of the project site would change from undeveloped to one with developed characteristics, a less than significant impact associated with the proposed project has been identified.

Development of the proposed project in conjunction with the cumulative projects identified in Table 5-1 will gradually change the visual character of this portion of the Imperial Valley. However, projects located within private lands and/or under the jurisdiction of the County of Imperial are being designed in accordance with the County of Imperial's General Plan and Land Use Ordinance, which includes policies to protect visual resources in the County.

Finally, all projects listed in Table 5-1 would not produce a substantial amount of light and glare, as no significant source of light or glare is proposed, or the project will otherwise comply with the County lighting ordinance, as would all other related projects. Based on these considerations, there would be no significant cumulatively considerable aesthetic impact, and cumulative aesthetic impacts would be less than significant.

5.3.2 Agricultural Resources

Cumulative impacts on agricultural resources take into account the proposed project's temporary impacts as well as those likely to occur as a result of other existing, proposed, and reasonably foreseeable projects. To determine cumulative impacts on agricultural resources, an assessment is made of the temporal nature of the impacts on individual resources (e.g., temporary such as in solar projects versus permanent as in industrial or residential developments) as well as the inventory of agricultural resources within the cumulative setting.

As discussed in Section 3.3, Agricultural Resources, the project does not contain Prime Farmland, Farmland of Statewide Importance, or Unique Farmland. Therefore, the proposed project would not convert land designated as Prime Farmland, Farmland of Statewide Importance, or Unique Farmland to non-agricultural uses or incrementally add to the conversion of agricultural land in Imperial County on a temporary or permanent basis. Furthermore, the project site is located within the Renewable

Energy Zone and is, therefore, considered an appropriate use in this area. Additionally, as a condition of project approval (CUP condition), the project applicant or its successor in interest will be responsible for implementing a reclamation plan when the project is decommissioned at the end of its lifespan.

A portion of the project site is designated as Farmland of Local Importance. It should be noted that analysis of Other Land and Farmland of Local Importance is not required under CEQA significance criteria, as these designations are not considered an “agricultural land” per CEQA Statute Section 21060.1(a). However, in terms of preservation of agricultural land Mitigation Measure AG-1 would be implemented to reduce potential impacts related to pests to a less than significant level. Each individual cumulative project would be or would have been required to provide mitigation for any impacts on agricultural resources in accordance with the County’s policies directed at mitigating the impact associated with the conversion of important farmlands. Therefore, the project’s contribution to this impact would be less than cumulatively considerable.

5.3.3 Air Quality

Imperial County is used as the geographic scope for analysis of cumulative air quality impacts. As shown in Table 5-1, many of the cumulative projects are large-scale renewable energy generation projects, where the main source of air emissions would be generated during the construction phases of these projects; however, there would also be limited operational emissions associated with operations and maintenance activities for these facilities. Additionally, several of the projects listed in Table 5-1 are already constructed and in operation. Furthermore, the remaining cumulative projects are currently under construction, or approved and not built (Iris Cluster – Lyons and Centinela Solar), and not anticipated to involve overlapping construction activities with the proposed project. Therefore, the potential for a cumulative, short-term air quality impact as a result of construction activities is anticipated to be less than significant.

Currently, the SSAB is either in attainment or unclassified for all federal and state air pollutant standards with the exception of 8-Hour O₃ and PM_{2.5}. On November 13, 2009, EPA published Air Quality Designations for the 2006 24-Hour Fine Particle (PM_{2.5}) NAAQS wherein Imperial County was listed as designated nonattainment for the 2006 24-hour PM_{2.5} NAAQS. However, the nonattainment designation for Imperial County is only for the urban area within the County and it has been determined that the proposed project is not located within the nonattainment boundaries for PM_{2.5}.

The AQAP for the SSAB, through the implementation of the AQMP and SIP for PM₁₀, sets forth a comprehensive program that will lead the SSAB into compliance with all federal and state air quality standards. With respect to PM₁₀, the ICAPCD implements Regulation VIII – Fugitive Dust Rules, to control these emissions and ultimately lead the basin into compliance with air standards, consistent with the AQAP. Within Regulation VIII are Rules 800 through 806, which address construction and earthmoving activities, bulk materials, carry-out and track-out, open areas, paved and unpaved roads, and conservation management practices. Best Available Control Measures to reduce fugitive dust during construction and earthmoving activities include but are not limited to:

- Phasing of work in order to minimize disturbed surface area;
- Application of water or chemical stabilizers to disturbed soils;
- Construction and maintenance of wind barriers; and
- Use of a track-out control device or wash down system at access points to paved roads.

Compliance with Regulation VIII is mandatory on all construction sites, regardless of size. However, compliance with Regulation VIII does not constitute mitigation under the reductions attributed to environmental impacts. In addition, compliance for a project includes: (1) the development of a dust control plan for the construction and operational phase; and (2) notification to the air district is required 10 days prior to the commencement of any construction activity.

Construction

The proposed project would generate air emissions due to vehicle and dust emissions associated with construction activities. Similar effects would also be realized upon site decommissioning, which would be carried out in conjunction with the project's restoration plan, and subject to applicable ICAPCD standards. Likewise, the other cumulative projects (Table 5-1), would result in the generation of air emissions during construction activities.

With respect to the proposed project, during the construction and decommissioning phases, the project would generate ROG, NO_x, CO, SO₂, PM₁₀, and PM_{2.5} emissions during each active day of construction. As discussed in Section 3.4, Air Quality, the project's daily construction emissions would not exceed the ICAPCD thresholds for ROG, NO_x, CO, SO₂, and PM_{2.5}. However, the project would exceed the ICAPCD threshold for PM₁₀ and represents a significant air quality impact. The project's impact could be cumulatively considerable because the Imperial County portion of the SSAB are nonattainment already for O₃ and PM₁₀ under state standards and for O₃ and PM_{2.5} federal standards. Thus, existing O₃ and PM₁₀ levels in the SSAB are at unhealthy levels during certain periods. Additionally, the cumulative construction effects could again be experienced in the future during decommissioning and site restoration activities.

Several of the projects listed in Table 5-1 are already constructed and in operation. Furthermore, the remaining cumulative projects, with exception of the Vikings Solar, Iris Cluster – Lyons, and Centinela Solar Projects, are currently under construction and not anticipated to involve overlapping construction activities with the proposed project. In the event the proposed project is constructed in conjunction with the Vikings Solar Project (pending entitlement), Iris Cluster – Lyons (approved but not built), and Centinela Solar Project (approved but not built), each project would be subject to mitigation pursuant to ICAPCD's Regulations. Therefore, the cumulative impact would be reduced to a level less than significant through compliance with these measures. Further, because the proposed project will be required to implement measures consistent with ICAPCD regulations designed to alleviate the cumulative impact associated with fugitive dust (PM₁₀) and NO_x, the project's contribution would be rendered less than cumulatively considerable and is therefore, less than significant.

Operation

As the proposed project would have no major stationary emission sources and would require minimal vehicular trips, operation of the proposed solar facility would result in substantially lower emissions than project construction. The project's operational emissions would not exceed the Tier I thresholds; therefore, the impact would be less than significant. Operational impacts of other renewable energy facilities identified in Table 5-1 would also be similar. Although these cumulative projects generally involve large areas, their operational requirements are very minimal, requiring minimal staff or use of machinery or equipment that generate emissions. Further, alternative energy projects, such as the project, would assist attainment of regional air quality standards and improvement of regional air quality by providing clean, renewable energy sources. Consequently, the projects would provide a

positive contribution to the implementation of applicable air quality plan policies and compliance with EO S-3-05.

However, from a cumulative air quality standpoint, the potential cumulative impact associated with the generation of O₃, PM_{2.5} and PM₁₀ emissions during operation of the cumulative projects is a consideration because existing O₃ and PM₁₀ levels in the SSAB are at unhealthy levels during certain periods. Imperial County is classified as non-attainment for PM_{2.5} for the urban areas of Imperial County. However, the project's operational contribution to O₃, PM_{2.5} and PM₁₀ would be below a level of significance. As with the construction phases, the cumulative projects would be required to comply with ICAPCD's Regulation VIII for dust control (Regulation VIII applies to both the construction and operational phases of projects). As a result, the ICAPCD would be required to comply with the various dust control measures and to prepare and implement operational dust control plans as approved by the ICAPCD, which is a component of ICAPCD's overall framework of the AQAP that sets forth a comprehensive program for SSAB's compliance with all federal and state air quality standards. Therefore, the project would not contribute to long-term cumulatively considerable air quality impacts and the project would not result in cumulatively significant air quality impacts, and cumulative impacts would be less than significant.

5.3.4 Biological Resources

The geographic scope for considering cumulative impacts on biological resources includes the Imperial Valley and related biological habitats. Table 5-1 lists the projects considered for the biological resources cumulative impact analysis.

In general terms, in instances where a potential impact could occur, CDFW and USFWS have promulgated a regulatory scheme that limits impacts on these species. The effects of the project would be rendered less than significant through implementation of Mitigation Measures BIO-1 to BIO-7 (Section 3.5, Biological Resources) which require compliance with all applicable regulations that protect plant, fish, and animal species. Other cumulative projects would also be required to avoid impacts on special-status species and/or mitigate to the satisfaction of the CDFW and USFWS for the potential loss of habitat. As described in Section 3.5, Biological Resources, the project has the potential to result in impacts on biological resources. These impacts are generally focused on potential construction-related effects to special-status plant species and wildlife.

The proposed project has been designed to avoid impacts to the riparian habitat, disturbed riparian habitat, and tamarisk thickets (CDFW sensitive natural community) within the project site. However, 14 special-status plant species that have the potential to occur within the project site. 11 of these plant species have a low potential to occur due to limited suitable habitat. Due to the presence of suitable habitat and several known recent occurrences within five miles of the project site, the following species were determined to have moderate potential to occur: Abram's spurge (CRPR 2B.2), Wiggins' croton (CRPR 2B.2), and sand food (CRPR 1B.2). Implementation of Mitigation Measures BIO-1, BIO-2, and BIO-3 would reduce project impacts to a level less than significant.

Burrowing Owls are protected by the CDFW mitigation guidelines for burrowing owl (CDFW 2012) and Consortium guidance (1993), which require a suite of mitigation measures to ensure direct effects to burrowing owls during construction activities are avoided and indirect effects through burrow destruction and loss of foraging habitat are mitigated at prescribed ratios. Additionally, as provided in Section 3.5, Biological Resources, special-status bird species have a potential to be present. In addition, several common bird species could nest on the project site. As a result of project-related construction activities, one or more of these protected species could be harmed. However, with the

implementation of Mitigation Measures BIO-2 through BIO-7, as identified in Section 3.5, Biological Resources, these impacts would be reduced to a level of less than significant.

As with the proposed project, the cumulative projects within the geographic scope of the project would be required to comply with the legal framework and provide mitigation for impacts on biological resources as described above. Based on these considerations, impacts on biological resources would not be cumulatively considerable.

The analysis below is conducted qualitatively and in the context that the cumulative projects would be subject to a variety of statutes and administrative frameworks that require mitigation for impacts on biological resources.

Birds listed at 50 CFR 10.3 are protected by the MBTA (16 USC 703 et seq.), a Federal statute that implements treaties with several countries on the conservation and protection of Birds listed at 50 CFR 10.3 are protected by the MBTA (16 USC 703 et seq.), a Federal statute that implements treaties with several countries on the conservation and protection of migratory birds. The MBTA is enforced by USFWS. This act prohibits the killing of any migratory birds without a valid permit. Any activity which contributes to unnatural migratory bird mortality could be prosecuted under this act. With few exceptions, most birds are considered migratory under this act. Raptors and active raptor nests are protected under California FGCs 3503.5, 3503, and 3513.

The CWA and California's Porter-Cologne Water Quality Control Act provide protection for water-related biological resources by controlling pollution, setting water quality standards, and preventing jurisdictional streams, lakes, and rivers from being filled without a federal permit. Freshwater forested/shrub wetland are present within the project site. Additionally, perennial and ephemeral drainage features are also present and convey flows in the wetlands within and around the All-American Canal. As such, these drainage features would likely be considered federally and state jurisdictional. However, the proposed project has been designed to avoid impacts to aquatic resources. As shown on the Site Plan (Figure 2-3), project components would not be sited on the project site where aquatic resources are present. Therefore, implementation of the project would result in no impact on state or federally protected aquatic resources.

The proposed project would comply with these and other laws, regulations and guidelines and therefore would not contribute substantially to a cumulative biological resources impact. Similarly, the cumulative projects within the geographic scope of the proposed project will be required to comply with the legal frameworks set forth above, as well as others, and will be required to mitigate their impacts to a less than significant level. Therefore, the project would not contribute to a cumulatively considerable impact to biological resources, and cumulative impacts would be less than significant.

5.3.5 Cultural Resources

As discussed in Section 3.6, Cultural Resources, five cultural resources are being treated as eligible for listing in the CRHR as historical resources. However, the project has been designed to avoid all five historical resources and Mitigation Measure CR-1 will be implemented to ensure the sites are avoided during construction. Mitigation Measure CR-1 requires the installation of orange environmentally sensitive area fencing or flagging around the boundaries of each of the resources prior to any construction activity and shall remain in place throughout project construction. Further, in the event that unknown cultural resources are discovered during project construction, significant impacts could occur. Therefore, Mitigation Measure CR-2 would be implemented to reduce potential impacts to previously unrecorded cultural resources to a level less than significant.

The potential of finding a buried archaeological site during construction is considered low. However, like all construction projects in the state, the possibility exists. This potential impact is considered significant. Implementation of Mitigation Measure CR-3 would reduce potential impacts associated with the unanticipated discovery of unknown buried archaeological resources. Additionally, implementation of Mitigation Measure CR-4 would reduce potential impacts on human remains to a level less than significant.

Future projects with potentially significant impacts on cultural resources would be required to comply with federal, state, and local regulations and ordinances protecting cultural resources through implementation of similar project-specific mitigation measures during construction. Therefore, through compliance with regulatory requirements, standard conditions of approval, and Mitigation Measures CR-1 through CR-4, the proposed project would have a less than cumulatively considerable contribution to impacts on cultural resources.

During operations and decommissioning of the project, no additional impacts on archeological resources would be anticipated because the soil disturbance would have already occurred and been mitigated during construction.

5.3.6 Geology and Soils

The Imperial Valley portion of the Salton Trough physiographic province of Southern California is used as the geographic scope for the analysis of cumulative impacts on geology/soils and mineral resources. Cumulative development would result in an increase in population and development that could be exposed to hazardous geological conditions, depending on the location of proposed developments. Geologic and soil conditions are typically site specific and can be addressed through appropriate engineering practices. Cumulative impacts on geologic resources would be considered significant if the project would be impacted by geologic hazard(s) and if the impact could combine with off-site geologic hazards to be cumulatively considerable. None of the projects identified within the geographic scope of potential cumulative impacts would intersect or be compounded with the project's site-specific geology and soils impacts which would be addressed by a site-specific geotechnical report per Mitigation Measure GEO-1. Therefore, no cumulatively considerable effects are identified for geology/soils, and cumulative impacts would be less than significant.

Development of the proposed project, in combination with other projects in the area, has the potential to contribute to a cumulatively significant paleontological resources impact due to the potential loss of paleontological resources unique to the region. However, mitigation is included in this EIR to reduce potentially significant project impacts to paleontological resources during construction of the proposed project. Implementation of Mitigation Measure GEO-2 would ensure that the potential impacts on paleontological resources do not rise to the level of significance. Future projects with potentially significant impacts on paleontological resources would be required to comply with federal, state, and local regulations and ordinances protecting paleontological resources through implementation of similar project-specific mitigation measures during construction. Therefore, through compliance with regulatory requirements, standard conditions of approval, and Mitigation Measure GEO-2, the proposed project would have a less than cumulatively considerable contribution to impacts on paleontological resources.

5.3.7 Greenhouse Gas Emissions

Emissions of GHGs have the potential to adversely affect the environment because such emissions contribute, on a cumulative basis, to global climate change. Although the emissions of the projects

alone would not cause global climate change, GHG emissions from multiple projects throughout the world could result in a cumulative impact with respect to global climate change. In turn, global climate change has the potential to result in rising sea levels, which can inundate low-lying areas; affect rainfall and snowfall, leading to changes in water supply; and affect habitat, leading to adverse effects on biological resources. The ICAPCD has not adopted a GHG significance threshold. Thus, in the absence of any GHG emissions significance thresholds, the projected emissions of the project are compared to the Mojave Desert Air Quality Management District (MDAQMD) numeric threshold of 100,000 metric tons of CO₂e annually. While significance thresholds used in the Mojave Desert Air Basin are not binding on the ICAPCD or County of Imperial, they are instructive as a comparative metric of the project's potential GHG impact. This threshold is also appropriate as the MDAQMD GHG thresholds were formulated based on similar geography and climate patterns as found in Imperial County. Therefore, the 100,000-metric ton of CO₂e threshold is appropriate for this analysis.

As discussed in Section 3.8, Greenhouse Gas Emissions, the proposed project's CO₂ emissions would not exceed MDAQMD's threshold of 100,000 MTCO₂e per year. As the project's emissions do not exceed the MDAQMD's significance threshold, the proposed project would not result in a cumulatively considerable impact to GHG emissions and would not conflict with the State GHG reduction targets. Other cumulative projects identified in Table 5-1 consist of utility-scale solar facilities. Like the project, the nature of these projects would be consistent with the strategies of the Climate Change Scoping Plan. In order to meet the AB 32 GHG emissions reduction mandate, the Scoping Plan relies on achievement of the RPS target of 33 percent of California's energy coming from renewable sources by 2020 and 50 percent by 2030. The RPS target was updated in September 2018 under SB 100 to 60 percent by 2030 and 100 percent by 2045. The project and other similar projects are essential to achieving the RPS.

Given that the project is characterized as a renewable energy project and places emphasis on solar power generation, project operations would be almost carbon-neutral with the majority of the operational GHG emissions associated with vehicle trips. Based on these considerations, no significant long-term operational GHG impacts would occur; therefore, project-related GHG impacts would not be cumulatively considerable.

5.3.8 Hazards/Hazardous Materials

The geographic scope considered for cumulative impacts from health, safety, and hazardous materials is the area within 1 mile of the boundary of the project site. One mile is the standard American Society of Testing and Materials (ASTM) standard search distance for hazardous materials.

Under cumulative conditions, implementation of the project in conjunction with the projects listed in Table 5-1 is not anticipated to present a public health and safety hazard to residents. Additionally, the project and related projects would all involve the storage, use, disposal, and transport of hazardous materials to varying degrees during construction, operation, and decommissioning. Impacts from these activities are less than significant for the project because the storage, use, disposal, and transport of hazardous materials are extensively regulated by various Federal, state, and local laws, regulations, and policies. It is foreseeable that the project and related projects would implement and comply with these existing hazardous materials laws, regulations, and policies. Therefore, the related projects would not cause a cumulative impact, and the project would not result in a cumulatively considerable incremental contribution to a cumulative impact related to use or routine transport of hazardous materials.

5.3.9 Hydrology and Water Quality

Table 5-1 lists the projects considered for the hydrology and water quality cumulative impact analysis. The geographic scope for considering cumulative hydrology and water quality impacts is the Imperial Valley Hydrologic Unit as defined by the Colorado Basin RWQCB Basin Plan.

The construction of the project is expected to result in short-term water quality impacts. Compliance with the SWRCB's NPDES general permit for activities associated with construction (2009-0009-DWQ) per Mitigation Measure HYD-1 would reduce water quality impacts. As with the project, future cumulative projects would be required to comply with the Construction General Permit. The SWRCB has determined that the Construction General Permit protects water quality, is consistent with the CWA, and addresses the cumulative impacts of numerous construction activities throughout the state. This determination in conjunction with the implementation of mitigation would ensure short-term water quality impacts are not cumulatively considerable.

The project is not expected to result in long-term operations-related impacts related to water quality. The project would mitigate potential water quality impacts by preparing a drainage plan that would implement site design, source control, and treatment control BMPs per Mitigation Measure HYD-2. Future cumulative projects may also be required to comply with the SWRCB's NPDES general permit for industrial activities, as well as rules found in the CWA, Section 402(p)(1) and 40 CFR 122.26, and implemented Order No. 90-42 of the RWQCB. With implementation of SWRCB, Colorado River RWQCB, and County policies, plans, and ordinances governing land use activities that may degrade or contribute to the violation of water quality standards, cumulatively considerable impacts on water quality would be minimized to a less than significant level.

Based on a review of the FEMA Flood Insurance Rate Map FIRM, the proposed solar energy facility, gen-tie line, and access roads located on the western portion of the project site are located in Zone X (unshaded). The FEMA Zone X (unshaded) designation is an area determined to be outside the 0.2 percent annual chance floodplain. As such, the project would not result in a significant cumulatively considerable impact on floodplains by constructing new facilities within an identified flood hazard zone.

Based on these considerations, the project would not contribute to or result in a significant cumulatively considerable impact to hydrology or water quality, and cumulative impacts would be less than significant.

5.3.10 Land Use Planning

The geographic scope for the analysis of cumulative land use and planning impacts is typically defined by government jurisdiction. The geographic scope for considering potential inconsistencies with the General Plan's policies from a cumulative perspective includes all lands within the County's jurisdiction and governed by its currently adopted General Plan. In contrast, the geographic scope for considering potential land use impacts or incompatibilities include the project site plus a one-mile buffer to ensure a consideration for reasonably anticipated potential direct and indirect cumulative impacts.

As provided in Section 3.11, Land Use/Planning, the project would not involve any facilities that could otherwise divide an established community. Based on this circumstance, no cumulatively considerable impacts would occur. As discussed in Section 3.11, Land Use/Planning, the project would not conflict with the goals and objectives of the County of Imperial General Plan. With approval of a CUP for the project, the proposed project would not conflict with the County's zoning ordinance. In addition, the cumulative projects identified in Table 5-1 would not result in a conflict with applicable land use plans, policies, or regulations. In the event that incompatibilities or land use conflicts are identified for other

projects listed in Table 5-1, similar to the project, the County would require mitigation to avoid or minimize potential land use impacts. Where General Plan Amendments and/or Zone Changes are required to extend the RE Overlay Zone, that project would be required to demonstrate consistency with the overall goals and policies of the General Plan, and would be required to demonstrate meeting the criteria for extending the RE Overlay onto the project site. Based on these circumstances, no significant cumulatively considerable impact would occur, and cumulative impacts would be less than significant.

5.3.11 Noise and Vibration

When determining whether the overall noise (and vibration) impacts from related projects would be cumulatively significant and whether the project's incremental contribution to any significant cumulative impacts would be cumulatively considerable, it is important to note that noise and vibration are localized occurrences; as such, they decrease rapidly in magnitude as the distance from the source to the receptor increases. Therefore, only those related projects and identified in Table 5-1 that are in the vicinity of the project site and those that are considered influential in regard to noise and vibration would have the potential to be considered in a cumulative context with the project's incremental contribution.

Several of the projects listed in Table 5-1 are already constructed and in operation. Furthermore, the remaining cumulative projects, with exception of the Vikings Solar, Iris Cluster – Lyons, and Centinela Solar Projects, are currently under construction and not anticipated to involve overlapping construction activities with the proposed project. As discussed in Section 3.12, Noise and Vibration, the project's noise levels would not exceed the County's 75 dBA L_{eq} construction noise threshold. Therefore, impacts from construction noise are considered less than significant. Similar to the proposed project, other cumulative projects would be required to comply with the County's construction noise standards. Construction activity is limited to the hours of 7 a.m. to 7 p.m. Monday through Friday, and 9 a.m. to 5 p.m. on Saturdays. Adhering to the County's construction hours would reduce the noise and vibration impacts to below a level of significance. Thus, the incremental contribution of the project to a cumulative noise impact would not be cumulatively considerable.

Stationary-source and vehicular noise from the aforementioned related projects would be similar in nature and magnitude to those discussed for the projects in Section 3.12, Noise and Vibration. For the proposed project, no noise impacts have been identified. Operation of the other cumulative projects listed in Table 5-1 could result in the long-term stationary source noise levels that exceed applicable standards at nearby sensitive receptors and/or result in substantial increases in ambient noise levels. However, given that the project facilities would be located at appropriate distances from the residential uses scattered in this portion of the County, long-term operational noise levels are not expected to exceed normally acceptable noise levels for these zones (e.g., 70 dBA L_{dn}). Thus, the incremental contribution of the project to significant cumulative noise impacts would not be cumulatively considerable.

5.3.12 Transportation

During the construction phase of the project, the maximum number of trips generated on a daily basis would be approximately 520 trips. Under construction year conditions with and without the proposed project, all roadway segments analyzed would operate at LOS A or better, all intersections would operate at a LOS B or better during both AM and PM peak hours, and all freeway segments would operate at LOS B or better during both AM and PM peak hours. Implementation of the proposed project

would not require any public road widening to accommodate vehicular trips associated with the proposed project (construction phase and operational phase), while maintaining adequate LOS. Additionally, future operations and maintenance would be conducted remotely, with minimal trips to the project site for panel washing and other solar maintenance.

Since the proposed project is located in a rural portion of the County there are no fixed routes for alternative transportation or non-motorized travel within the general area of the project site that would be impacted by project construction or operation. Although the proposed project would increase VMT during the construction phase, these increases are temporary in nature. Operation of proposed projects would only require intermittent maintenance which would result in a nominal amount of vehicle trips generated.

A majority of the projects listed in Table 5-1 are already constructed. Furthermore, the remaining cumulative projects, with exception of the Vikings Solar, Iris Cluster – Lyons, and Centinela Solar Projects, are currently under construction and not anticipated to involve overlapping construction activities with the proposed project. The other cumulative projects would also likely result in a nominal amount of vehicle trips for maintenance and operation as a solar facility. Based on these findings, the proposed project would not result in cumulatively considerable roadway or intersection impacts, and this impact would be less than significant.

5.3.13 Tribal Cultural Resources

As discussed in Section 3.14, Tribal Cultural Resources, a SLF search request was submitted on September 15, 2020 to the California NAHC and the search results were received on September 29, 2020. The search of the SLF was negative and failed to indicate the presence of Native American cultural resources in the project area. Additionally, on April 1, 2021, the Quechan Indian Tribe requested consultation with the County on the proposed project. The County is in the process of consulting with the Quechan Indian Tribe and has requested that they to provide any information regarding any Traditional Cultural Properties, Sacred Sites, resource collecting areas, or any other areas of concern known to occur in the project area. However, the proposed project is not anticipated to cause a substantial adverse change in the significance of a tribal cultural resource, defined in PRC section 21074 or a resource determined by the lead agency, in its discretion and supported by substantial evidence, to be significant pursuant to criteria set forth in subdivision (c) of PRC Section 5024.1 and Section 5024.1.

Future cumulative projects would also be required to comply with the requirements of AB 52 to determine the presence/absence of tribal cultural resources and engage in consultation to determine appropriate mitigation measures to minimize or avoid impacts on tribal cultural resources. Based on these considerations, the project would not contribute to or result in a significant cumulatively considerable impact tribal cultural resources. During operations and decommissioning of the project, no impacts on tribal cultural resources are anticipated because the soil disturbance would have already occurred and been mitigated during construction.

5.3.14 Utilities/Service Systems

Future development in Imperial County would increase the demand for utility service in the region. In terms of cumulative impacts, the appropriate service providers are responsible for ensuring adequate provision of public utilities within their jurisdictional boundaries. The project would not require or result in the relocation or construction of new or expanded wastewater facilities, storm water facilities, or



water facilities. Additionally, the project would be comprised of mostly recyclable materials and would not generate significant volumes of solid waste that could otherwise contribute to significant decreases in landfill capacity. Based on these considerations, the project would result in less than significant impacts on existing utility providers and, therefore, would not result in cumulatively considerable impacts.

This page is intentionally blank.

6 Effects Found Not Significant

In accordance with Section 15128 of the CEQA Guidelines, an EIR must contain a statement briefly indicating the reasons that various potential significant effects of a project were determined not to be significant. Based on the Initial Study and Notice of Preparation prepared for the proposed project (Appendix A of this EIR), Imperial County has determined that the proposed project would not have the potential to cause significant adverse effects associated with the topics identified below. Therefore, these topics are not addressed in this EIR; however, the rationale for eliminating these topics is briefly discussed below.

6.1 Agriculture and Forestry Resources

6.1.1 Forestry Resources

No portion of the project site or the immediate vicinity is zoned or designated as forest lands, timberlands, or timberland production. As such, the proposed project would not result in a conflict with existing zoning or cause the need for a zone change. Therefore, implementation of the proposed project would not impact forestry resources.

6.2 Energy

Information for this section is summarized from the Energy Impact Assessment prepared by ECORP Consulting, Inc. This report is included in Appendix M of this EIR.

6.2.1 Energy Types and Sources

California relies on a regional power system comprised of a diverse mix of natural gas, renewable, hydroelectric, and nuclear generation resources. Natural gas provides California with a majority of its electricity followed by renewables, large hydroelectric and nuclear. IID, the sixth largest electrical utility in California serving more than 150,000 customers in the Imperial Valley and parts of Riverside and San Diego counties, provides electrical services to the project area. IID controls more than 1,100 megawatts of energy derived from a diverse resource portfolio that includes its own generation, and long- and short-term power purchases. Located in a region with abundant sunshine, enviable geothermal capacity, wind and other renewable potential, IID has met or exceeded all Renewable Portfolio Standard requirements to date, procuring renewable energy from diverse sources, including biomass, biowaste, geothermal, hydroelectric, solar and wind (Appendix M of this EIR).

The Southern California Gas Company provides natural gas services to Imperial County. As the nation's largest natural gas distribution utility, the Southern California Gas Company delivers natural gas energy to 21.6 million consumers through 5.9 million meters in more than 500 communities. The Southern California Gas Company's service territory encompasses approximately 20,000 square miles throughout Central and Southern California, from Visalia to the Mexican border (Appendix M of this EIR).

6.2.2 Imperial County Energy Consumption

Electricity

The electricity consumption associated with all uses in Imperial County from 2015 to 2019 is shown in Table 6-1. As shown, the demand has remained constant since 2015.

Table 6-1. Electricity Consumption in Imperial County 2015–2019

Year	Electricity Consumption (kilowatt hours)
2019	1,415,790,908
2018	1,467,590,638
2017	1,445,167,336
2016	1,440,493,016
2015	1,419,088,130

Source: Appendix M of this EIR

Natural Gas

The natural gas consumption associated with all uses in Imperial County from 2015 to 2019 is shown in Table 6-2. As shown, the demand has increased since 2015.

Table 6-2. Natural Gas Consumption in Imperial County 2015–2019

Year	Natural Gas Consumption (therms)
2019	42,914,053
2018	38,729,625
2017	40,442,318
2016	36,089,854
2015	31,494,256

Source: Appendix M of this EIR

Automotive Fuel Consumption

Automotive fuel consumption in Imperial County from 2016 to 2020 is shown in Table 6-3. As shown, fuel consumption has decreased between 2016 and 2020.

Table 6-3. Automotive Fuel Consumption in Imperial County 2016–2020

Year	Total Fuel Consumption (gallons)
2020	196,177,597
2019	198,822,094
2018	201,793,138
2017	204,312,157
2016	208,822,214

Source: Appendix M of this EIR

6.2.3 Proposed Project Energy Consumption

The project is proposing the development of a 100 MW alternating current PV energy generation system with an integrated 100 MW battery system. Operation of the proposed project would not result in the consumption of electricity or natural gas and thus, would not contribute to the County wide usage and would directly support the RPS goal of increasing the percentage of electricity procured from renewable sources.

Therefore, the energy analysis focuses on the two sources of energy that are most relevant to the project: the equipment fuel necessary for construction and the automotive fuel necessary for ongoing maintenance activities. The amount of total construction-related fuel use was estimated using ratios provided in the Climate Registry’s General Reporting Protocol for the Voluntary Reporting Program, Version 2.1. The amount of operational fuel use was estimated using CARB’s EMFAC2017 computer program, which provides projections for typical daily fuel usage in Imperial County. This analysis conservatively assumes that all of the automobile trips projected to arrive at the project site during operations would be new to Imperial County.

Energy consumption associated with the proposed project is summarized in Table 6-4. Project increases in automotive fuel consumption are compared with the countywide fuel consumption in 2020 (Table 6-3), the most recent full year of data.

Table 6-4. Proposed Project Energy and Fuel Consumption

Energy Type	Annual Energy Consumption	Percentage Increase Countywide
Electricity Consumption	0 kilowatt-hours	0.00000 percent
Natural Gas	0 therms	0.00000 percent
Automotive Fuel Consumption		
Project Construction 2022	77,931 gallons	0.03971 percent
Project Construction 2023	45,123 gallons	0.02299 percent
Project Operations	128 gallons	0.00006 percent

Source: Appendix M of this EIR

Notes: The project increases in electricity and natural gas consumption are compared with all uses in Imperial County in 2019, the latest data available. The project increases in automotive fuel consumption are compared with the countywide fuel consumption in 2020, the most recent full year of data.

Fuel necessary for project construction would be required for the operation and maintenance of construction equipment and the transportation of materials to the project site. The fuel expenditure necessary to construct the solar facility and infrastructure would be temporary, lasting only as long as project construction. As shown in Table 6-4, the project’s gasoline fuel consumption during the onetime construction period is estimated to be 77,931 gallons during 2022 construction and 45,123 gallons during 2023 construction. This would increase the annual countywide gasoline fuel use in the county by 0.03971 percent and 0.02299 percent, respectively. As such, project construction would have a nominal effect on local and regional energy supplies. No unusual project characteristics would necessitate the use of construction equipment that would be less energy efficient than at comparable construction sites in the region or the state. Construction contractors would purchase their own gasoline and diesel fuel from local suppliers and would judiciously use fuel supplies to minimize costs due to waste and subsequently maximize profits. Additionally, construction equipment fleet turnover and increasingly stringent state and federal regulations on engine efficiency combined with state regulations limiting engine idling times and requiring recycling of construction debris, would further reduce the amount of transportation fuel demand during project construction. For these reasons, it is

expected that construction fuel consumption associated with the project would not be any more inefficient, wasteful, or unnecessary than other similar development projects of this nature.

Once construction is completed the project would be remotely controlled. No employees would be based at the project site. The only operational emissions associated with the project would be associated with motor vehicle use for routine maintenance work and site security as well as panel upkeep and cleaning. A conservative estimate of one vehicle trip per day generated by the project was assumed. This is a conservative estimate as most days would require no operational related vehicle trips. As shown in Table 6-4, this would estimate to a consumption of approximately 128 gallons of automotive fuel per year, which would increase the annual countywide automotive fuel consumption by 0.00006 percent. Fuel consumption associated with both the construction equipment needed to construction the project and the vehicle trips generated by the project during ongoing maintenance activities would not be considered inefficient, wasteful, or unnecessary in comparison to other similar developments in the region. The proposed project would result in a less than significant impact related to energy.

6.2.4 Compliance with State or Local Plans for Renewable Energy or Energy Efficiency

The purpose of the proposed project is the construction of a renewable energy and storage facility in Imperial County. Once in operation, it will decrease the need for energy from fossil fuel-based power plants in the state. The result would be a net increase in electricity resources available to the regional grid, generated from a renewable source. Therefore, the project would directly support the RPS goal of increasing the percentage of electricity procured from renewable sources. Additionally, the project would also be consistent with the County's General Plan Conservation and Open Space Element, Objective 9.2 which encourages renewable energy developments. Therefore, the project would directly support state and local plans for renewable energy development. The proposed project would not conflict with or obstruct a state or local plan for renewable energy or energy efficiency; therefore, no impact would occur.

6.3 Mineral Resources

The project site is not used for mineral resource production and the applicant is not proposing any form of mineral extraction. According to Figure 8: Imperial County Existing Mineral Resources of the Conservation and Open Space Element of the General Plan (County of Imperial 2016), no known mineral resources occur within the project site nor does the project site contain mapped mineral resources. Therefore, the proposed project would not result in the loss of availability of any known mineral resources that would be of value to the region and the residents of California nor would the proposed project result in the loss of availability of a locally important mineral resource.

Based on a review of the California Department Division of Oil, Gas, and Geothermal Resources Well Finder, there is a plugged and abandoned well (Well No. 02590233) located in the north-central portion of the project site (APN 059-300-015) (California Department of Oil, Gas, and Geothermal Resources 2021). The well is located on a portion of the project site that would remain undeveloped (identified as non-usable land on the Site Plan [Figure 2-3]) and thereby avoided by the proposed project. Therefore, implementation of the proposed project would not impact any wells.

6.4 Population and Housing

Development of housing is not proposed as part of the project. No full-time employees are required to operate the project. The project facility will be monitored remotely. It is anticipated that maintenance of the facility will require minimal site presence to perform periodic visual inspections and minor repairs. On intermittent occasions, the presence of additional workers may be required for repairs or replacement of equipment and panel cleaning; however, due to the nature of the facility, such actions will likely occur infrequently. Therefore, the proposed project would not result in a substantial growth in the area, as the number of employees required to operate and maintain the facility is minimal.

No housing exists within the project site and no people reside within the project site. Therefore, the proposed project would not displace substantial numbers of people or housing, necessitating the construction of replacement housing elsewhere. The proposed project would result in no impact to population and housing.

6.5 Public Services

Fire Protection. Fire protection and emergency medical services in the area are provided by the Imperial County Fire Department. The project site is located in the unincorporated area of Imperial County. According to the Seismic and Public Safety Element of the General Plan (County of Imperial 1997), the potential for a major fire in the unincorporated areas of the County is generally low. Both the access and service roads (along the perimeter of the project facility) would have turnaround areas to allow clearance for fire trucks per fire department standards. Although the proposed project would be designed, constructed, and operated in accordance with applicable fire protection and other environmental, health, and safety requirements (e.g., CPUC safety standards), the project applicant will be required to consult and coordinate with the Fire Department to address any fire safety and service concerns (i.e. battery storage system fire prevention and control components), and emergency response site access, so that adequate service is maintained. While the proposed project may result in an increase in demand for fire protection service, with installation of internal fire prevention systems and ICFD consultation, including adherence to any special conditions regarding fire control and access, the project would not result in an increase in demand that would, in turn, result in a substantial adverse physical impact associated with the provision of new or physically altered fire protection facilities; the construction of which could cause significant environmental impacts, in order to maintain acceptable service ratios, response times, or other performance objectives for any of the public services. Based on these considerations, the project would not result in a need for fire facility expansion and a less than significant impact would occur.

Imperial County requires payment of impact fees for new development projects. Fire Impact Fees are imposed pursuant to Ordinance 1418 §2 (2006), which was drafted in accordance with the County's TischlerBise Impact Fee Study. The ordinance has provisions for non-residential industrial projects based on square footage. The project applicant will be required to pay the fire protection services' impact fees. These fees would be included in the Conditions of Approval for the CUP and would therefore be less than significant.

Police Protection. Police protection services in the project area is provided by the Imperial County Sheriff's Department. Although the potential is low, the proposed project may attract vandals or other security risks. The increase in construction related traffic could increase demand on law enforcement services. However, the project site would be fenced with 6-foot high chain link security fence and points of ingress/egress would be accessed via locked gates. In addition, periodic on-site personnel

visitations for security would occur during operations and maintenance of the proposed project, thereby minimizing the need for police surveillance. While the proposed project may result in a temporary increase in demand for law enforcement service, the project would not result in an increase in demand that would, in turn, result in a substantial adverse physical impact associated with the provision of new or physically altered sheriff facilities, the construction of which could cause significant environmental impacts, in order to maintain acceptable service ratios, response times or other performance objectives for any of the public services. Further, as conditions of approval of the project, the project applicant will be required to participate in the Imperial County Public Benefit Program for the life of this CUP and shall at all times be a party to a public benefit agreement in a form acceptable to County Counsel in order to pay for all costs, benefits, and fees associated with the approved project, and the applicant will be required to reimburse the Sheriff's Department for any investigations regarding theft on the project site and related law enforcement. Approval of this public benefit agreement will be required by the Board of Supervisors prior to the issuance of the first building permit. These potential impacts are less than significant.

Schools. The proposed project does not include the development of residential land uses that would result in an increase in population or student generation. Construction of the proposed project would not result in an increase in student population within the Imperial County's School District since it is anticipated that construction workers would commute in during construction operations. The proposed project would have no impact on Imperial County schools.

Parks and Other Public Facilities. No full-time employees are required to operate the project. The project facility will be monitored remotely. It is anticipated that maintenance of the facility will require minimal site presence to perform periodic visual inspections and minor repairs. Therefore, substantial permanent increases in population that would adversely affect local parks, libraries, and other public facilities are not expected. The project is not expected to have an impact on parks, libraries, and other public facilities.

6.6 Recreation

The project site is not used for formal recreational purposes. Also, the proposed project would not generate new employment on a long-term basis. As such, the project would not significantly increase the use or accelerate the deterioration of regional parks or other recreational facilities. The temporary increase of population during construction that might be caused by an influx of workers would be minimal and not cause a detectable increase in the use of parks. Additionally, the project does not include or require the expansion of recreational facilities. Therefore, no impact is identified for recreation.

6.7 Utilities and Service Systems

Wastewater Facilities. The project would generate a minimal volume of wastewater during construction. During construction activities, wastewater would be contained within portable toilet facilities and disposed of at an approved site. No habitable structures are proposed on the project site, such as O&M buildings; therefore, there would be no wastewater generation from the proposed project. The proposed project would not require or result in the relocation or construction of new or expanded wastewater facilities.

Storm Water Facilities. The proposed project will involve the construction of drainage control facilities within the project site, and included in the project impact footprint, of which environmental impacts have been evaluated. Otherwise, the project does not require expanded or new storm drainage

facilities off-site (i.e., outside of the project footprint) because the proposed solar facility would not generate a significant increase in the amount of impervious surface that would increase runoff during storm events, and therefore, would not require the construction of off-site storm water management facilities. Water from solar panel washing would continue to percolate through the ground, as a majority of the surfaces within the project site would remain pervious. The proposed project would not require or result in the relocation or construction of new or expanded storm water facilities beyond those proposed as part of the project and evaluated in the EIR.

Water Facilities. The proposed project is not anticipated to result in a significant increase in water demand/use during operation; however, water will be needed for solar panel washing and dust suppression. During operation, water would be trucked to the project site from a local water source. Therefore, the proposed project would not require or result in the relocation or construction of new or expanded water facilities.

Power, Natural Gas, and Telecommunication Facilities. The proposed project would involve construction of power facilities. However, these are components of the project as evaluated in the EIR. The proposed project would not otherwise generate the demand for or require or result in the relocation or construction of new or expanded electric power, natural gas, or telecommunications facilities that would in turn, result in a significant impact to the environment.

Solid Waste Facilities. Solid waste generation would be minor for the construction and operation of the project. Solid waste would be disposed of using a locally-licensed waste hauling service, most likely Allied Waste. Trash would likely be hauled to the Calexico Solid Waste Site (13-AA-0004) located approximately 13 miles west of the proposed project in Calexico. As of August 1, 2019, the Calexico Solid Waste Site has approximately 1,561,235 cubic yards of remaining capacity and is estimated to remain in operation through 2179 (CalRecycle 2021). Therefore, there is ample landfill capacity in the County to receive the minor amount of solid waste generated by construction and operation of the proposed project.

Additionally, because the proposed project would generate solid waste during construction and operation, the project would be required to comply with state and local requirements for waste reduction and recycling; including the 1989 California Integrated Waste Management Act and the 1991 California Solid Waste Reuse and Recycling Access Act of 1991. Also, conditions of the CUP would contain provisions for recycling and diversion of Imperial County construction waste policies.

Further, when the proposed project reaches the end of its operational life, the components would be decommissioned and deconstructed. When the project concludes operations, much of the wire, steel, and modules of which the system is comprised would be recycled to the extent feasible. The project components would be deconstructed and recycled or disposed of safely, and the site could be converted to other uses in accordance with applicable land use regulations in effect at the time of closure. Commercially reasonable efforts would be used to recycle or reuse materials from the decommissioning. All other materials would be disposed of at a licensed facility. A less than significant impact is identified for this issue.

6.8 Wildfire

According to the Draft Fire Hazard Severity Zone Map for Imperial County prepared by the California Department of Forestry and Fire Protection, the project site is not located in or near state responsibility areas or lands classified as very high hazard severity zones (California Department of Forestry and Fire Protection 2007). Therefore, the proposed project would not substantially impair an adopted emergency response plan or emergency evacuation plan; expose project occupants to, pollutant

concentrations from a wildfire or the uncontrolled spread of a wildfire; exacerbate fire risk; or expose people or structures to significant risks, including downslope or downstream flooding or landslides, as a result of runoff, post-fire slope instability, or drainage changes. No impact is identified for wildfire.

7 Alternatives

7.1 Introduction

The identification and analysis of alternatives is a fundamental concept under CEQA. This is evident in that the role of alternatives in an EIR is set forth clearly and forthrightly within the CEQA statutes. Specifically, CEQA §21002.1(a) states:

“The purpose of an environmental impact report is to identify the significant effects on the environment of a project, to identify alternatives to the project, and to indicate the manner in which those significant effects can be mitigated or avoided.”

The CEQA Guidelines require an EIR to “describe a range of reasonable alternatives to the project, or to the location of the project, which would feasibly attain most of the basic objectives of the project but would avoid or substantially lessen any of the significant effects of the project and evaluate the comparative merits of the alternatives” (CEQA Guidelines §15126.6(a)). The CEQA Guidelines direct that selection of alternatives focus on those alternatives capable of eliminating any significant environmental effects of the project or of reducing them to a less-than significant level, even if these alternatives would impede to some degree the attainment of project objectives or would be more costly. In cases where a project is not expected to result in significant impacts after implementation of recommended mitigation, review of project alternatives is still appropriate.

The range of alternatives required within an EIR is governed by the “rule of reason” which requires an EIR to include only those alternatives necessary to permit a reasoned choice. The discussion of alternatives need not be exhaustive. Furthermore, an EIR need not consider an alternative whose implementation is remote and speculative or whose effects cannot be reasonably ascertained.

Alternatives that were considered but were rejected as infeasible during the scoping process should be identified along with a reasonably detailed discussion of the reasons and facts supporting the conclusion that such alternatives were infeasible.

Based on the alternatives analysis, an environmentally superior alternative is designated among the alternatives. If the environmentally superior alternative is the No Project Alternative, then the EIR shall identify an environmentally superior alternative among the other alternatives (CEQA Guidelines §15126.6(e)(2)).

7.2 Criteria for Alternatives Analysis

As stated above, pursuant to CEQA, one of the criteria for defining project alternatives is the potential to attain the project objectives. Established objectives of the project applicant for the proposed project include:

- Construct and operate a solar energy facility capable of producing up to 100-megawatt (MW) alternating current (AC) of electricity to assist the State of California in achieving its 60 percent renewable portfolio standard by 2030.
- Provide a 100 MW energy (battery storage) system, that would accommodate and store the power generated by the project so that the facility can continue to provide renewable energy during non-daylight hours.

- Interconnect directly to IID’s existing electrical transmission system.
- Help California meet its statutory and regulatory goal of increasing renewable power generation, including greenhouse gas reduction goals of Senate Bill 32.
- Minimize and mitigate any potential impact to sensitive environmental resources within the project area.

7.3 Alternatives Considered but Rejected

7.3.1 Alternative Site

Section 15126.6(f)(2) of the CEQA Guidelines addresses alternative locations for a project. The key question and first step in the analysis is whether any of the significant effects of the proposed project would be avoided or substantially lessened by constructing the proposed project in another location. Only locations that would avoid or substantially lessen any of the significant effects of the project need to be considered for inclusion in the EIR. Further, CEQA Guidelines Section 15126.6(f)(1) states that among the factors that may be considered when addressing the feasibility of alternative locations are whether the project proponent can reasonably acquire, control or otherwise have access to the alternative site (or the site is already owned by the proponent).

The proponent does not have control of an alternate site; if control were viable, the proponent would have to re-initiate the application process as a new project. Similar to the proposed project site, an alternate site would require environmental review once the proponent has prepared sufficient project description information. At present, the proponent does not have control of an alternate site. This alternative would be the most complex, costly, and time-consuming alternative to implement. It is unknown if the environmental impacts associated with this Alternative would be less than the proposed project because it would be speculative to evaluate an unsecured alternate site. This is primarily due to the fact that the proponent does not have control of an alternate site. Therefore, an alternative site was eliminated from further consideration in this EIR.

7.3.2 Original Site Plan Submittal

The project applicant originally proposed to construct and operate a 100 MW solar energy facility with an integrated 100 MW battery storage system on approximately 531 acres (APNs 059-290-010, 059-300-015, and 059-300-017). Based on a biological reconnaissance survey of the 531-acre site, the following sensitive vegetation communities were found to be present on the western parcel (APN 059-209-010): arrow weed thickets, tamarisk thickets, and alkali weed – salt grass playas and sinks. Furthermore, one freshwater emergent wetland occurs on the western parcel. To minimize impacts on biological resources, the project applicant re-designed the project to remove the western parcel (APN 059-209-010). The western parcel would not be developed. This re-design reduced the original project site from 531 acres to 450 acres.

The original site plan on 531 acres would result in increased biological resources impacts and increased jurisdictional water impacts compared to the proposed project. Therefore, the County rejects to original site plan from further analysis.

7.3.3 Original Access Route for Heavy Construction Equipment

The project applicant’s originally proposed access route for heavy construction equipment was via State Route 98 east to the East Highline Check of the All-American Canal bridge crossing to the project

entrance. After coordination with the IID, IID determined that the bridge crossing would not be able to handle the weight of heavy construction equipment.

Although the use of the original access route would be a shorter distance to the project site and would result in less miles traveled, the County rejects the original access route from further analysis due to increased hazards and safety impacts.

7.4 Alternative 1: No Project/No Development Alternative

The CEQA Guidelines require analysis of the No Project Alternative (PRC Section 15126). According to Section 15126.6(e)(1), “the specific alternative of ‘no project’ shall also be evaluated along with its impact.” Also, pursuant to Section 15126.6(e)(2); “The ‘no project’ analysis shall discuss the existing conditions at the time the notice of preparation is published, ... at the time environmental analysis is commenced, as well as what would be reasonably expected to occur in the foreseeable future if the project were not approved, based on current plans and consistent with available infrastructure and community services.”

The No Project/No Development Alternative assumes that the project, as proposed, would not be implemented and the project site would not be further developed with a solar energy project. The No Project/No Development Alternative would fail to meet any of the project objectives.

7.4.1 Environmental Impact of Alternative 1: No Project/No Development Alternative

Aesthetics and Visual Resources

Under the No Project/No Development Alternative, the project site would not be developed and would continue to be undeveloped, partially disturbed land. The No Project/No Development Alternative would not modify the existing project site or add construction to the project site therefore, there would be no change to the existing condition of the site. Under this alternative, there would be no potential to create a new source of light or glare associated with the PV arrays. A less than significant aesthetic impact (including potential light and glare impact) has been identified associated with the project. However, because there would be no change to the existing condition of the project site under this alternative, there would be no potential impact associated with a change in visual character of the site and the potential aesthetic impact would be less as compared to the project as the existing visual conditions would not change.

Agricultural Resources

Under the No Project/No Development Alternative, the project site would not be developed and continue to be undeveloped, partially disturbed land. Compared to the proposed project, implementation of this alternative would avoid the temporary conversion of land designated as Other Land and Farmland of Local Importance per the Farmland Mapping and Monitoring Program (FMMP) to non-agricultural uses. However, as previously indicated, these designations are not considered an “agricultural land” per CEQA Statute Section 21060.1(a). Therefore, this alternative would not contribute to the conversion of agricultural lands or otherwise adversely affect agricultural operations. Compared to the proposed project, this alternative would avoid the need for future restoration of the project site to pre-project conditions.

Air Quality

Under the No Project/No Development Alternative, there would be no air emissions associated with project construction or operation, and no project- or cumulative-level air quality impact would occur. Therefore, no significant impacts to air quality or violation of air quality standards would occur under this alternative. Moreover, this alternative would be consistent with existing air quality attainment plans and would not result in the creation of objectionable odors.

As discussed in Section 3.4, Air Quality, the proposed project would not exceed the ICAPCD's significance thresholds for emissions of ROG, CO, NO_x, and PM_{2.5} during both the construction and operational phases of the project. However, the project would exceed the ICAPCD threshold for PM₁₀. Pursuant to ICAPCD, all construction sites, regardless of size, must comply with the requirements contained within Regulation VIII – Fugitive Dust Control Measures. The project must comply with the requirements of ICAPCD Regulation VIII for the control of fugitive dust (Mitigation Measure AQ-1). With the implementation of the ICAPCD Regulation VIII requirements (Mitigation Measure AQ-1), the project would not exceed the ICAPCD's thresholds of significance for PM₁₀ emissions. This alternative would result in less air quality emissions compared to the proposed project, the majority of which would occur during construction. The No Project/No Development Alternative would not reduce the long-term need for renewable electricity generation. As a consequence, while the No Project/No Development Alternative would not result in new impacts to air quality as a result of construction, it would likely not realize the overall benefits to regional air quality when compared to the operation of the proposed project.

Biological Resources

Under the No Project/No Development Alternative, existing biological resource conditions within the project site would largely remain unchanged and no impact would be identified. Unlike the proposed project which requires mitigation for biological resources including Abram's spurge, burrowing owl, and other migratory birds, this alternative would not result in construction of a solar facility that could otherwise result in significant impacts to these biological resources. Compared to the proposed project, this alternative would avoid impacts to biological resources.

Cultural Resources

The proposed project would involve ground-disturbing activities that have the potential to impact known historical resources and disturb previously undocumented cultural resources that could qualify as historical resources or unique archaeological resources pursuant to CEQA. Under the No Project/No Development Alternative, the project site would not be developed and no construction-related ground disturbance would occur. Therefore, compared to the proposed project, this alternative would avoid impacts to cultural resources.

Geology and Soils

Because there would be no development at the project site under the No Project/No Development Alternative, no grading or construction of new facilities would occur. Therefore, there would be no impact to project-related facilities as a result of local seismic hazards (strong ground shaking), liquefaction, lateral spreading, collapsible soils, expansive soils, corrosive soils, soil erosion, and paleontological resources. In contrast, the proposed project would require the incorporation of mitigation measures related to strong ground shaking, liquefaction, collapsible soils, expansive soils, corrosive soils, soil erosion, and paleontological resources to minimize impacts to a level less than

significant. Compared to the proposed project, this alternative would avoid significant impacts related to local geology and soil conditions and paleontological resources.

Greenhouse Gas Emissions

Under the No Project/No Development Alternative, there would be no GHG emissions resulting from project construction or operation or corresponding impact to global climate change. The No Project/No Development Alternative would not help California meet its statutory and regulatory goal of increasing renewable power generation, including GHG reduction goals of SB 32. While this alternative would not further implement policies for GHG reductions, this alternative would also not directly conflict with any applicable plan, policy, or regulation adopted for the purpose of reducing the emissions of GHGs. This alternative would not create any new GHG emissions during construction but would not lead to a long-term beneficial impact to global climate change by providing renewable clean energy. For the proposed project, a less than significant impact was identified for construction-related GHG emissions, and in the long-term, the project would result in an overall beneficial impact to global climate change as the result of creation of clean renewable energy, that does not generate GHG emissions. Compared to the proposed project, while the No Project/No Development Alternative would not result in new GHG emissions during construction, it would be less beneficial to global climate change as compared to the proposed project. Further, the construction emissions (amortized over 30 years) associated with the project would be off-set by the beneficial renewable energy provided by the project, negating any potential that the No Project/No Development alternative would reduce construction-related GHG emissions.

Hazards and Hazardous Materials

The No Project/No Development Alternative would not include any new construction. Therefore, no potential exposure to hazardous materials would occur. Therefore, no impact is identified for this alternative for hazards and hazardous materials. As with the proposed project, this alternative would not result in safety hazards associated with airport operations. Although a less than significant impact is identified for hazards and hazardous materials associated with the project, compared to the proposed project, this alternative would have less of an impact related to hazards and hazardous materials as there would be no potential for the transport, use, removal or disposal of hazardous materials.

Hydrology/Water Quality

The No Project/No Development Alternative would not result in modifications to the existing drainage patterns or volume of storm water runoff as attributable to the proposed project, as the existing site conditions and on-site pervious surfaces would remain unchanged. In addition, no changes with regard to water quality would occur under this alternative. Compared to the proposed project, from a drainage perspective, this alternative would avoid changes to existing hydrology. Under this alternative, there would be no water demand. This alternative would have less of an impact associated with hydrology/water quality as compared to the proposed project.

Land Use Planning

Under the No Project/No Development Alternative, the project site would not be developed and continue to be undeveloped, partially disturbed land. Current land uses would remain the same. No existing community would be divided, and no inconsistencies with land use planning policies would occur. Because no significant Land Use and Planning impact has been identified associated with the

proposed project, this alternative would not avoid or reduce a significant impact related to this issue and therefore, it is considered similar to the proposed project.

Noise

This alternative would not require construction or operation of the project facilities; therefore, this alternative would not increase ambient noise levels within the vicinity of the project site. For this reason, no significant noise impacts would occur. As discussed in Section 3.12, Noise and Vibration, the proposed project would not result in significant noise impacts to sensitive receptors during construction and operation. Compared to the proposed project, this alternative would not generate noise and would have less of an impact associated with noise.

Transportation

There would be no new development under the No Project/No Development Alternative. Therefore, this alternative would not generate vehicular trips during construction or operation. For these reasons, no impact would occur and this alternative would not impact any applicable plan, ordinance, or policy addressing the performance of the circulation system, substantially increase hazards because of a design feature, or result in inadequate emergency access. Although the proposed project would result in less than significant transportation impacts, this alternative would avoid an increase in vehicle trips on local roadways, and any safety related hazards that could occur in conjunction with the increase vehicle trips and truck traffic, primarily associated with the construction phase of the project.

Tribal Cultural Resources

The proposed project is not anticipated to cause a substantial adverse change in the significance of a tribal cultural resource. Impacts to tribal cultural resources under the No Project/No Development Alternative are similar to the proposed project.

Utilities and Service Systems

The No Project/No Development Alternative would not require the expansion or extension of existing utilities, since there would be no new project facilities that would require utility service. No solid waste would be generated under this alternative. The proposed project would not result in any significant impacts to existing utilities or solid waste facilities. Compared to the proposed project, this alternative would have less of an impact related to utilities and solid waste facilities.

Conclusion

Implementation of the No Project/No Development Alternative would generally result in reduced impacts for a majority of the environmental issues areas considered in Chapter 3, Environmental Analysis when compared to the proposed project. A majority of these reductions are realized in terms of significant impacts that are identified as a result of project construction. However, this alternative would not realize the benefits of reduced GHG emissions associated with energy use, which are desirable benefits that are directly attributable to the proposed project.

Comparison of the No Project/No Development Alternative to Project Objectives

The No Project/No Development Alternative would not meet any of the objectives of the project. Additionally, the No Project/No Development Alternative would not help California meet its statutory

and regulatory goal of increasing renewable power generation, including GHG reduction goals of SB 32.

7.5 Alternative 2: Reduced Project Site

The purpose of this alternative is to reduce the size of the project site to minimize impacts on biological resources by increasing the setback of the project from sensitive vegetation communities and aquatic resources. Tamarisk thickets, identified by CDFW as a sensitive natural community, have been mapped on the northern parcel (APN 059-300-015) of the project site. Freshwater forested/shrub wetland, riparian habitat, and disturbed riparian habitat have also been mapped on the northern parcel of the project site. This alternative would remove the northern parcel (APN 059-300-015), thereby reducing the project site by 301 acres from 450 acres to 149 acres.

7.5.1 Environmental Impact of Alternative 2: Reduced Project Site

Aesthetics and Visual Resources

Under Alternative 2, the overall size of the solar energy facility would be reduced. No significant visual aesthetic impact has been identified as the proposed project's facilities would not impact scenic resources, result in the substantial degradation of the existing visual character of the project site or add a substantial amount of light and glare. As such, this alternative would not avoid or reduce any significant impacts identified for the project and the aesthetic impact would be similar to the proposed project.

Agricultural Resources

Under Alternative 2, the overall size of the solar energy facility would be reduced. This alternative would reduce the temporary conversion of land designated as Other Land and Farmland of Local Importance. However, as previously indicated, these designations are not considered an "agricultural land" per CEQA Statute Section 21060.1(a). Therefore, similar to the proposed project, this alternative would not contribute to the conversion of agricultural lands or otherwise adversely affect agricultural operations. Similar to the proposed project, the need for future restoration of the project site to pre-project conditions would be required under this alternative.

Air Quality

Under Alternative 2, air emissions during construction would be less than the proposed project because of the reduced site development. A less than significant impact with mitigation incorporated has been identified for the proposed project during construction. Similar to the proposed project, this alternative would be required to comply with the requirements of ICAPCD Regulation VIII for the control of fugitive dust. Similar to the proposed project, this alternative would be consistent with existing AQAPs and would not result in the creation of objectionable odors. This alternative would provide less MW generation compared to the proposed project, thereby reducing its ability to provide a long-term source of renewable energy. Compared to the proposed project, while this alternative would result in less air quality impacts, it would likely provide fewer desirable benefits to overall regional air quality as attributable to the proposed project.

Biological Resources

Under Alternative 2, the overall size of the solar energy facility would be reduced by 301 acres. Under Alternative 2, impacts on biological resources would be reduced by increasing the setback of the project from sensitive vegetation communities (tamarisk thickets) and aquatic resources (freshwater forested/shrub wetland, riparian habitat, and disturbed riparian habitat). Although the overall size of the solar energy facility would be reduced, there is still potential for impacts on special-status species such as Abram's spurge and burrowing owl. Compared to the proposed project, this alternative would result in a reduction in impacts on biological resources but would still require mitigation.

Cultural Resources

Although the overall size of the solar energy facility would be reduced by 301 acres, this alternative would still require ground-disturbing activities, which has the potential to disturb undocumented cultural resources that could qualify as historical resources or unique archaeological resources pursuant to CEQA, and human remains. Compared to the proposed project, this alternative would result in a reduction in impacts on cultural resources because of the reduced site development but would still require mitigation.

Geology and Soils

Under Alternative 2, while the overall project footprint would be reduced, grading and construction of new facilities, such as the solar facility, battery energy storage, and gen-tie, would still occur. This alternative would still be subject to potential impacts related to strong ground shaking, liquefaction, soil erosion, collapsible soils, expansive soils, and paleontological resources, and would require the incorporation of mitigation measures to minimize these impacts to a less than significant level. This alternative would result in similar geology and soil and paleontological resources impacts as the proposed project.

Greenhouse Gas Emissions

Under Alternative 2, the overall project footprint would be reduced by approximately 301 acres thereby contributing to reductions in GHG emissions during project construction. However, as a consequence of the reduced size of the project, this alternative would result in a reduced power production capacity as compared to the proposed project; hence, the overall benefits of the project to global climate change through the creation of renewable energy would also be reduced. This alternative would not conflict with any applicable plan, policy, or regulation adopted for the purpose of reducing GHG emissions. Similar to the proposed project, this alternative would not exceed MDAQMD's threshold of 100,000 MTCO₂e. Compared to the proposed project, this alternative would contribute to similar and desirable reductions in GHG emissions and associated contribution to global climate change through the production of renewable energy, although to a lesser degree. Because no significant GHG impact has been identified associated with the proposed project, this alternative would not avoid or reduce a significant impact related to this issue and, therefore, it is considered similar to the proposed project.

Hazards and Hazardous Materials

Similar to the proposed project, construction of this alternative would involve the limited use of hazardous materials, such as fuels and greases to fuel and service construction equipment. Also, as with the proposed project, because the Phase I ESA prepared for the proposed project did not identify and on-site RECs, ASTs, or USTs, this alternative would not avoid or reduce impacts associated with

hazardous materials. Further, no impact associated with potential safety hazards to the public residing or working within proximity to a public airport would occur. Implementation of this alternative would result in a similar hazards and hazardous materials impact as the proposed project. This alternative would not avoid or lessen the impact to hazards and hazardous materials as no significant impact associated with the proposed project has been identified.

Hydrology/Water Quality

Alternative 2 would result in modifications to the existing drainage patterns and the volume of storm water runoff, as this alternative would introduce impervious area on-site, although to a lesser degree than the proposed project. Because the overall project footprint would be reduced, this alternative would realize a minor reduction in the corresponding impacts on hydrology and on-site drainage; however, the same mitigation measures would be applicable to this alternative. Similar to the proposed project, no impacts would result from flooding and facilities will not be placed within floodplains. Compared to the proposed project, this alternative would result in less of an impact on hydrology/water quality.

Land Use Planning

Implementation of this alternative would not avoid or reduce a land use and planning impact, as no significant impact associated with the project has been identified. As with the proposed project, this alternative would be consistent with the County Land Use Ordinance, Division 17, RE Overlay Zone, which authorizes the development and operation of RE projects with an approved CUP. Implementation of this alternative would be similar to the proposed project with respect to land use and planning.

Noise

As with the proposed project, Alternative 2 would not result in significant noise impacts associated with construction activities. As with the proposed project, operational impacts associated with this alternative would not expose persons or generate noise levels in excess of applicable noise standards, exposure persons to, or generate excessive groundborne vibration, or expose persons to excessive aircraft noise. Because no significant noise impact has been identified associated with the proposed project, this alternative would not avoid or reduce a significant impact related to this issue and therefore, it is considered similar to the proposed project.

Transportation

This alternative would result in a similar level of construction and operation-related vehicle and truck trips as compared to the proposed project. However, the increase in vehicular traffic was identified as a less than significant impact for the proposed project. In this context, Alternative 2 would not reduce or avoid an impact related to transportation and would result in less than significant impacts similar to the proposed project. As with the proposed project, Alternative 2 would not impact any applicable plan, ordinance, or policy addressing the performance of the circulation system, substantially increase hazards because of a design feature, result in inadequate emergency access, or conflict with public transit, bicycle, or pedestrian facilities. This alternative would result in a similar impact related to transportation as the proposed project.

Tribal Cultural Resources

Implementation of this alternative would not avoid or reduce a tribal cultural resources impact, as no significant impact associated with the project has been identified. Impacts to tribal cultural resources under this alternative are similar to the proposed project.

Utilities and Service Systems

Implementation of this alternative would result in an overall less demand for utilities, including water. However, this alternative would not avoid or reduce a significant impact associated with the project as a less than significant impact to utilities has been identified associated with the project. Implementation of this alternative would not achieve to the same degree the beneficial impacts of providing renewable energy. As compared to the proposed project, the overall demand for utilities would be less under this alternative.

Conclusion

As shown on Table 7-1, this alternative would reduce impacts to agricultural resources, air quality, biological resources, cultural resources, hydrology/water quality, and utilities/service systems.

Comparison of Alternative 2: Reduced Project Site

Alternative 2 would meet most of the basic objectives of the proposed project and should remain under consideration. However, this alternative would make it more difficult to achieve the overall objective of providing a total of 100 MW of renewable solar energy, as there would be less area available for the placement of PV structures.

7.6 Environmentally Superior Alternative

Table 7-1 provides a qualitative comparison of the impacts for each alternative compared to the proposed project. As noted on Table 7-1, the No Project/No Development Alternative would be considered the environmentally superior alternative, since it would eliminate all of the significant impacts identified for the project. However, CEQA Guidelines Section 15126.6(e)(2) states that “if the environmentally superior alternative is the No Project Alternative, the EIR shall also identify an environmentally superior alternative among the other alternatives.” As shown on Table 7-1, Alternative 2 would reduce impacts for the following environmental issue areas as compared to the proposed project: agricultural resources, air quality, biological resources, cultural resources, hydrology/water quality, and utilities/service systems. Therefore, Alternative 2 is considered the Environmentally Superior Alternative.



Table 7-1. Comparison of Alternative Impacts to Proposed Project

Environmental Issue Area	Proposed Project	Alternative 1: No Project/No Development	Alternative 2: Reduced Project Site
Aesthetics and Visual Resources	Less than Significant	<i>CEQA Significance:</i> No Impact <i>Comparison to Proposed Project:</i> Less Impact	<i>CEQA Significance:</i> Less than Significant <i>Comparison to Proposed Project:</i> Similar Impact
Agricultural Resources	Less than Significant with Mitigation	<i>CEQA Significance:</i> No Impact <i>Comparison to Proposed Project:</i> Less Impact (Avoid)	<i>CEQA Significance:</i> Less than Significant with Mitigation <i>Comparison to Proposed Project:</i> Less Impact
Air Quality	Less than Significant with Mitigation	<i>CEQA Significance:</i> No Impact <i>Comparison to Proposed Project:</i> Less Impact	<i>CEQA Significance:</i> Less than Significant with Mitigation <i>Comparison to Proposed Project:</i> Less Impact
Biological Resources	Less than Significant with Mitigation	<i>CEQA Significance:</i> No Impact <i>Comparison to Proposed Project:</i> Less Impact (Avoid)	<i>CEQA Significance:</i> Less than Significant with Mitigation <i>Comparison to Proposed Project:</i> Less Impact
Cultural Resources	Less than Significant with Mitigation	<i>CEQA Significance:</i> No Impact <i>Comparison to Proposed Project:</i> Less Impact (Avoid)	<i>CEQA Significance:</i> Less than Significant with Mitigation <i>Comparison to Proposed Project:</i> Less Impact

Table 7-1. Comparison of Alternative Impacts to Proposed Project

Environmental Issue Area	Proposed Project	Alternative 1: No Project/No Development	Alternative 2: Reduced Project Site
Geology and Soils	Less than Significant with Mitigation	<i>CEQA Significance:</i> No Impact <i>Comparison to Proposed Project:</i> Less Impact (Avoid)	<i>CEQA Significance:</i> Less than Significant with Mitigation <i>Comparison to Proposed Project:</i> Similar Impact
GHG Emissions	Less than Significant	<i>CEQA Significance:</i> No Impact <i>Comparison to Proposed Project:</i> Less Impact	<i>CEQA Significance:</i> Less than Significant <i>Comparison to Proposed Project:</i> Similar Impact
Hazards and Hazardous Materials	Less than Significant	<i>CEQA Significance:</i> No Impact <i>Comparison to Proposed Project:</i> Less Impact	<i>CEQA Significance:</i> Less than Significant <i>Comparison to Proposed Project:</i> Similar Impact
Hydrology/ Water Quality	Less than Significant with Mitigation	<i>CEQA Significance:</i> No Impact <i>Comparison to Proposed Project:</i> Less Impact (Avoid)	<i>CEQA Significance:</i> Less than Significant with Mitigation <i>Comparison to Proposed Project:</i> Less Impact
Land Use/Planning	No Impact	<i>CEQA Significance:</i> No Impact <i>Comparison to Proposed Project:</i> Similar Impact	<i>CEQA Significance:</i> No Impact <i>Comparison to Proposed Project:</i> Similar Impact



Table 7-1. Comparison of Alternative Impacts to Proposed Project

Environmental Issue Area	Proposed Project	Alternative 1: No Project/No Development	Alternative 2: Reduced Project Site
Noise and Vibration	Less than Significant	<i>CEQA Significance:</i> No Impact <i>Comparison to Proposed Project:</i> Less Impact	<i>CEQA Significance:</i> Less than Significant <i>Comparison to Proposed Project:</i> Similar Impact
Transportation	Less than Significant	<i>CEQA Significance:</i> No Impact <i>Comparison to Proposed Project:</i> Less Impact	<i>CEQA Significance:</i> Less than Significant <i>Comparison to Proposed Project:</i> Similar Impact
Tribal Cultural Resources	Less than Significant	<i>CEQA Significance:</i> No Impact <i>Comparison to Proposed Project:</i> Less Impact	<i>CEQA Significance:</i> Less than Significant <i>Comparison to Proposed Project:</i> Similar Impact
Utilities/Service Systems	Less than Significant	<i>CEQA Significance:</i> No Impact <i>Comparison to Proposed Project:</i> Less Impact	<i>CEQA Significance:</i> Less than Significant <i>Comparison to Proposed Project:</i> Less Impact

This page is intentionally blank.

8 References

- Avian Powerline Interaction Committee (APLIC). 1996. Suggested Practices for Raptor Protection on Power Lines.
- . 2012. Reducing Avian Collisions with Power Lines. Available on-line at: https://www.aplic.org/uploads/files/15518/Reducing_Avian_Collisions_2012watermarkLR.pdf.
- . 2020. California Greenhouse Gas Inventory for 2000–2018 – by Category as Defined in the 2008 Scoping Plan. https://ww3.arb.ca.gov/cc/inventory/data/tables/ghg_inventory_scopingplan_sum_2000-18.pdf.
- . 2016. Ambient Air Quality Standards. Available on-line at https://ww2.arb.ca.gov/sites/default/files/2020-03/aaqs2_0.pdf.
- CARB. 2017. Climate Change Scoping Plan. Accessed, April 28, 2021. <https://ww2.arb.ca.gov/our-work/programs/ab-32-climate-change-scoping-plan/2017-scoping-plan-documents>.
- California Department of Conservation (DOC). 2021. California Important Farmland Finder. Available on-line at <https://maps.conservation.ca.gov/DLRP/CIFF/>. Accessed on April 28, 2021.
- . 2018. Alternate Imperial County 2016–2018 Land Use Conversation Table A-9.
- . 2016. Imperial County Williamson Act FY 2016/2017.
- California Department of Fish and Game. 2012. *Staff Report on Burrowing Owl Mitigation*. March 7, 2012.
- California Department of Forestry and Fire Protection. 2007. Fire Hazard Severity Zones in SRA – Imperial County. Adopted by CALFIRE on November 7, 2007.
- California Department of Oil, Gas, and Geothermal Resources. 2021. Geologic Energy Management Division’s Well Finder. Available online at <https://maps.conservation.ca.gov/doggr/wellfinder/#openModal/-118.94276/35.22235/6>. Accessed on April 30, 2021.
- California Native Plant Society. 2001. *Inventory of Rare and Endangered Plants of California* (sixth edition). Rare Plant Scientific Advisory Committee, David P. Tibor, Convening Editor. California Native Plant Society, Sacramento, CA. 388 pp.
- CalRecycle. 2021. SWIS Facility/Site Activity Details – Calexico Solid Waste Site (13-AA-0004). Available online at <https://www2.calrecycle.ca.gov/SolidWaste/SiteActivity/Details/4179?siteID=591>. Accessed on April 30, 2021.
- Caltrans. 2020. Transportation and Construction Vibration Guidance Manual. Available online at <https://dot.ca.gov/-/media/dot-media/programs/environmental-analysis/documents/env/tcvgm-apr2020-a11y.pdf>.
- California Department of Water Resources. 2004. California’s Groundwater Bulletin 118. Imperial Valley Groundwater Basin. Available online at <https://water.ca.gov/-/media/DWR-Website/>

[Web-Pages/Programs/Groundwater-Management/Bulletin-118/Files/2003-Basin-Descriptions/7_030_ImperialValley.pdf](#).

California Natural Resources Agency. 2018. A Summary of Key Findings from California's Fourth Climate Change Assessment. https://www.energy.ca.gov/sites/default/files/2019-11/20180827_Summary_Brochure_ADA.pdf.

California Regional Water Quality Control Board (RWQCB). 2019. Water Quality Control Plan for the Colorado River Basin Region.

County of Imperial. 2020. Land Use Ordinance. Title 9. Division 5: Zoning Areas Established. <https://www.icpds.com/assets/5-Zoning-Areas-Established-.pdf>.

——— 2016. Conservation and Open Space Element.

——— 2015. Agricultural Element.

——— 2008. Circulation and Scenic Highways Element.

——— 1997. Seismic and Public Safety Element.

——— 1996. Airport Land Use Compatibility Plan, Imperial County Airports.

Federal Emergency Management Agency (FEMA). 2008. Flood Insurance Rate Map, Map Number Panel 06025C2125C. Effective Date September 26, 2008.

FTA. 2018. Transit Noise and Vibration Impact Assessment. Available online at: https://www.transit.dot.gov/sites/fta.dot.gov/files/docs/research-innovation/118131/transit-noise-and-vibration-impact-assessment-manual-fta-report-no-0123_0.pdf.

Imperial County Air Pollution Control District (ICAPCD). 2018a. 2018 Redesignation Request and Maintenance Plan for Particulate Matter Less than 10 Microns in Diameter. Adopted October 23, 2018.

——— 2018b. 2018 Annual Particulate Matter Less than 2.5 Microns in Diameter State Implementation Plan. April 2018.

——— 2009. Final 2009 Imperial County State Implementation Plan for Particulate Matter Less than 10 Microns in Aerodynamic Diameter. August 11, 2009.

——— 2017a. 2017 State Implementation Plan for the 2008 8-Hour Ozone Standard. September 2017.

——— 2017b. CEQA Air Quality Handbook. As amended December 12, 2017.

——— 2014. Final 2013 State Implementation Plan for the 2006 24-Hour PM_{2.5} Moderate Nonattainment Area. December 2, 2014.

Imperial County Agricultural Commissioner. 2019. 2019 Imperial County Agricultural Crop & Livestock Report.

Imperial County Office of Emergency Services (OES). 2016. Imperial County Emergency Operations Plan.

Imperial Valley Transit. 2021. About Us. Available on-line at: <https://www.ivtransit.com/about-us>. Accessed December 21, 2021.

- Natural Resources Agency (NRA). 2018. Technical Advisory on Evaluating Transportation Impacts in CEQA. https://opr.ca.gov/docs/20190122-743_Technical_Advisory.pdf.
- Regional Water Quality Control Board. 2018. *2018 California Integrated Report: Appendix A, 303(d) List of Impaired Waterbodies*. Accessed January 12, 2022. https://www.waterboards.ca.gov/water_issues/programs/water_quality_assessment/2018_integrated_report.html.
- Southern California Association of Governments (SCAG). 2020. 2020–2045 Regional Transportation Plan/Sustainable Communities Strategy (Connect SoCal). <https://scag.ca.gov/connect-socal>.
- State of California Employment Development Department. 2022. Immediate Release, El Centro Metropolitan Statistical Area (MSA) (Imperial County). October 21, 2022.
- U.S. Environmental Protection Agency. 2016. Final Rulemaking to Establish Greenhouse Gas Emissions Standards and Fuel Efficiency Standards for Medium- and Heavy-Duty Engines and Vehicles – Phase 2. October 25, 2016. Available online at <https://www.govinfo.gov/content/pkg/FR-2016-10-25/pdf/2016-21203.pdf>.
- . 2011. Final Rulemaking to Establish Greenhouse Gas Emissions Standards and Fuel Efficiency Standards for Medium- and Heavy-Duty Engines and Vehicles. September 5, 2011. Available online at: <https://www.govinfo.gov/content/pkg/FR-2011-09-15/pdf/2011-20740.pdf>.
- U.S. Fish and Wildlife Service. 1996. USFWS Guidelines for Conducting and Reporting Botanical Inventories for Federally Listed, Proposed, and Candidate Plants.

This page is intentionally blank.

9 EIR Preparers and Persons and Organizations Contacted

9.1 EIR Preparers

This EIR was prepared for the County of Imperial by HDR at 591 Camino de la Reina, Suite 300, San Diego, CA 92108. The following professionals participated in its preparation:

County of Imperial

Jim Minnick, Planning & Development Services Director

Michael Abraham, AICP, Assistant Planning & Development Services Director

Diana Robinson, Planning Division Manager

David Black, Planner IV

HDR

Tim Gnibus, Principal

Sharyn Del Rosario, Project Manager

Terrileigh Pellarin, Senior Environmental Planner

Regan Del Rosario, Environmental Planner

Katherine Turner, Document Production Administrator

HDR was assisted by the following consultants:

ECORP Consulting, Inc.

Visual Impact Assessment; Air Quality and Greenhouse Gas Assessment; Biological Technical Report; Aquatic Resources Delineation; Cultural Resources Inventory, Testing and Evaluation Report; Noise Impact Assessment; Energy Impact Assessment

GS Lyon Consultants, Inc.

Phase I Environmental Site Assessment

KOA

Traffic Impact Study

9.2 Persons and Organizations Contacted

The following persons and organizations were contacted in preparation of this document:

- Imperial Irrigation District
- U.S Border Patrol

- Bureau of Reclamation
- Quechan Indian Tribe, Fort Yuma Indian Reservation

Appendix A

Initial Study and Notice of Preparation and
Responses

Notice of Preparation

To: Office of Planning & Research
(Agency)

P.O. Box 3044, 1400 Tenth Street, Room 212
(Address)

Sacramento, CA 95812-3044

Subject: Notice of Preparation of a Draft Environmental Impact Report

Lead Agency:

Consulting Firm (If applicable):

Agency Name Imperial County, Planning & Dev Svcs.

Firm Name HDR

Street Address 801 Main Street

Street Address 591 Camino de la Reina, Suite 300

City/State/Zip El Centro, CA 92243

City/State/Zip San Diego, CA 92108

Contact Diana Robinson

Contact Tim Gnibus

The County of Imperial will be the Lead Agency and will prepare an Environmental Impact Report (EIR) for the project identified below. We need to know the views of your agency as to the scope and content of the Environmental Information, which is germane to your agency’s statutory responsibilities in connection with the proposed project. Your agency will need to use the EIR prepared by our agency when considering your permit or other approval for the project.

The project description, location, and the potential environmental effects are contained in the attached materials. A copy of the Initial Study is attached.

Due to the time limits mandated by State law, your response must be sent at the earliest possible date but ***not later than 35 days*** after receipt of this notice.

Please send your response to Imperial County Planning & Development Services, Attn: Diana Robinson at the address shown above. We will need the name for a contact person in your agency.

Project Title: VEGA SES 4 Solar Energy Project


Project Location: The project site is located on approximately 531 acres of privately-owned land in the southernmost portion of Imperial County, California. The project site is between the U.S./Mexico international border and the All-American Canal, on the California side. The project site is proposed on three parcels (Assessor Parcel Numbers 059-290-010, 059-300-015, and 059-300-017) that are contiguous with each other. It is approximately 10 miles east of the City of Calexico in Sections 10, 11, 14, 15, and 16 within Township 17 South, and Range 16 East of the San Bernardino Base and Meridian of the Bonds Corner topographic 7.5 minute quadrangle. As shown on Figure 1, the project site is located entirely within the County’s Renewable Energy Overlay Zone.

Project Description (brief): The proposed project consists of three primary components: 1) solar energy generation equipment and associated facilities including a substation and access roads (herein referred to as “solar energy facility”); 2) battery storage system; and, 3) gen-tie line that would connect the proposed on-site substation to the point of interconnection at the existing Imperial Irrigation District’s (IID) 92-kV “P” line.

The proposed project involves the construction of a 100-megawatt (MW) alternating current (AC) photovoltaic (PV) solar energy facility with an integrated 100 MW battery storage system (not to exceed 200 MW) on approximately 531 acres of land. The project proposes to utilize either thin film or crystalline solar PV technology modules

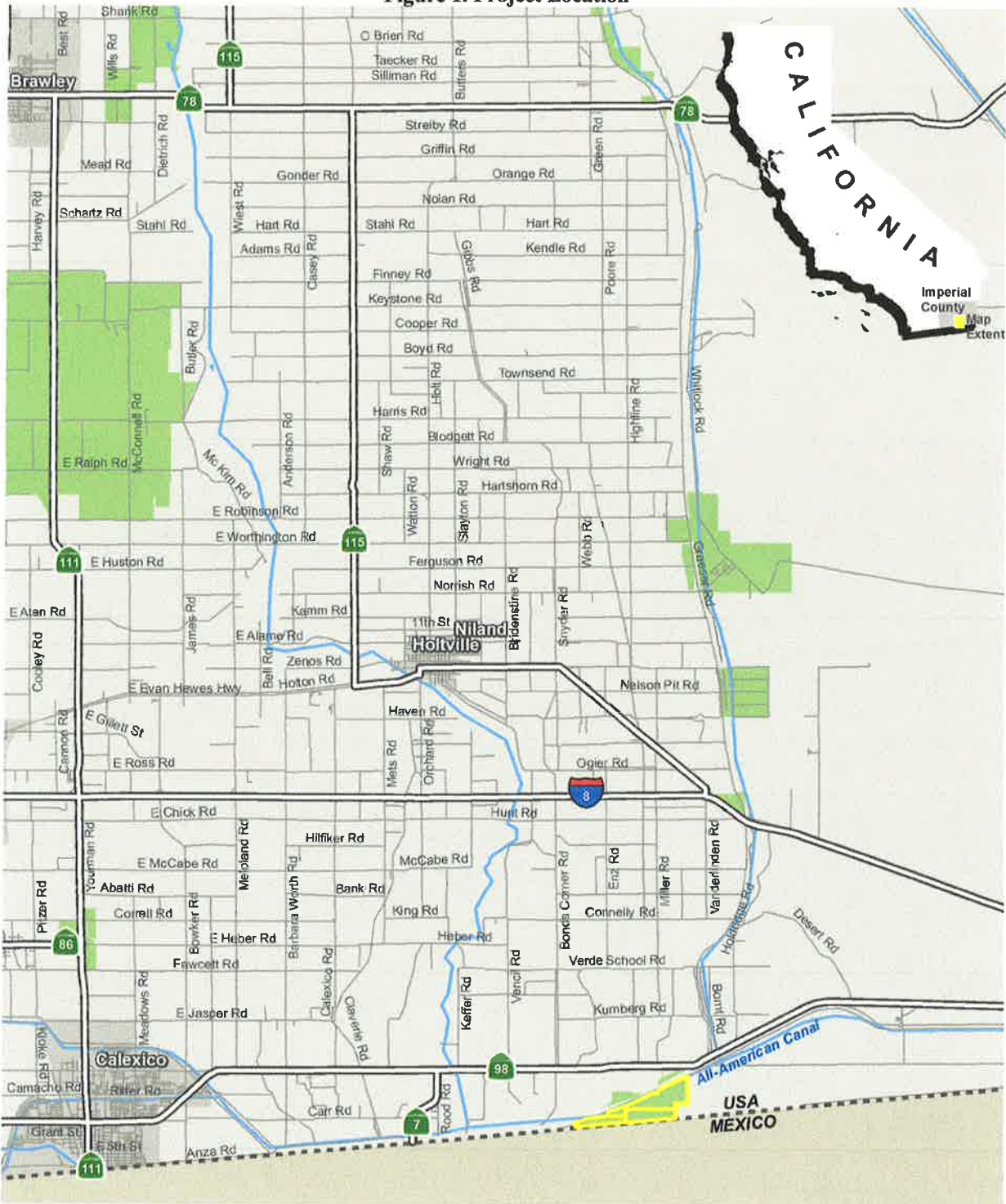
mounted either on fixed frames or horizontal single-axis tracker systems. The project would include electronic/electrical equipment, an on-site substation, access road(s) and fencing. The electrical energy produced by the project would be conducted through the project's interconnection facilities to the proposed 92 kV generator intertie (gen-tie) line and delivered to the existing IID approved point of interconnection on the 92-kV "P" Line.

Project Applicant: Apex Energy Solutions, LLC



Date	<u>April 30, 2021</u>	Signature	<u></u>
		Title	<u>Assistant Director</u>
		Telephone	<u>442-265-1736</u>

Reference: California Administrative Code, Title 14, (CEQA Guidelines) Section 15082(a), 15103, 15375.

Figure 1. Project Location



LEGEND

-  VEGA SES 4 Project Area
-  Renewable Energy Overlay Zone



This page is intentionally blank.

PUBLIC NOTICE

**Imperial County
Planning & Development Services Department**

**NOTICE OF PREPARATION OF DRAFT EIR FOR VEGA SES 4 SOLAR ENERGY PROJECT
AND NOTICE OF PUBLIC EIR SCOPING MEETING**

The Imperial County Planning & Development Services Department intends to prepare an Environmental Impact Report (EIR) for the proposed VEGA SES 4 Solar Energy Project as described below. A public scoping meeting for the proposed EIR will be held by the Imperial County Planning & Development Services Department on **May 13 at 6:00 P.M.** The scoping meeting will be held at the Board of Supervisors Chambers, 2nd Floor, County Administration Center located at 940 Main Street, El Centro, CA 92243. Comments regarding the scope of the EIR will be accepted at this meeting.

SUBJECT: VEGA SES 4 Solar Energy Project EIR

BOARD OF SUPERVISORS CONSIDERATION: To Be Determined.

PROJECT LOCATION: The project site is located on approximately 531 acres of privately-owned land in the southernmost portion of Imperial County, California. The project site is between the U.S./Mexico international border and the All-American Canal, on the California side. The project site is proposed on three parcels (Assessor Parcel Numbers 059-290-010, 059-300-015, and 059-300-017) that are contiguous with each other. It is approximately 10 miles east of the City of Calexico in Sections 10, 11, 14, 15, and 16 within Township 17 South, and Range 16 East of the San Bernardino Base and Meridian of the Bonds Corner topographic 7.5 minute quadrangle. The project site is located entirely within the County's Renewable Energy Overlay Zone.

PROJECT DESCRIPTION: The proposed project consists of three primary components: 1) solar energy generation equipment and associated facilities including a substation and access roads (herein referred to as "solar energy facility"); 2) battery storage system; and, 3) gen tie line that would connect the proposed on site substation to the point of interconnection at the existing Imperial Irrigation District's (IID) 92 kV "P" line.

The proposed project involves the construction of a 100-megawatt (MW) alternating current (AC) photovoltaic (PV) solar energy facility with an integrated 100 MW battery storage system (not to exceed 200 MW) on approximately 531 acres of land. The project proposes to utilize either thin film or crystalline solar PV technology modules mounted either on fixed frames or horizontal single-axis tracker systems. The project would include electronic/electrical equipment, an on-site substation, access road(s) and fencing. The electrical energy produced by the project would be conducted through the project's interconnection facilities to the proposed 92 kV generator intertie (gen-tie) line and delivered to the existing IID approved point of interconnection on the 92-kV "P" Line.

Project Applicant: Apex Energy Solutions, LLC

URBAN AREA PLAN: None, located in unincorporated area of County of Imperial

BOARD OF SUPERVISORS DISTRICT: District 1, Supervisor Jesus E. Escobar

ANTICIPATED SIGNIFICANT EFFECTS: The EIR will analyze potential impacts associated with the following: Aesthetics; Agricultural Resources; Air Quality; Biological Resources; Cultural Resources; Geology/Soils; Greenhouse Gas Emissions/Climate Change; Hazards and Hazardous Materials; Hydrology/Water Quality; Land Use/Planning; Noise; Public Services; Transportation; Tribal Cultural Resources; Utilities and Service Systems including water supply, Cumulative Impacts; and, Growth-Inducing Impacts.

COMMENTS REQUESTED: The Imperial County Planning & Development Services Department would like to know your ideas about the potential effects this project might have on the environment and your suggestions as to mitigation or ways the project may be revised to reduce or avoid any potentially significant environmental impacts. Your comments will guide the scope and content of potential environmental issues to be examined in the EIR. Your comments may be submitted in writing to Diana Robinson, Imperial County Planning & Development Services Department, 801 Main Street, El Centro, CA 92243. Available project information may be reviewed at this location.

NOTICE OF PREPARATION REVIEW PERIOD: May 4, 2021 through June 7, 2021

Legal 9031

Publish: May 6, 2021

Initial Study



Initial Study and NOP

VEGA SES 4 Solar Energy Project

Imperial County, CA

August 2022

Reviewed by:

County of Imperial
Planning & Development
Services Department
801 Main Street
El Centro, CA 92243

Prepared by:

HDR Engineering, Inc.
591 Camino de la Reina,
Suite 300
San Diego, CA 92108

This page is intentionally blank.



Contents

Introduction.....	1
A. Purpose	1
B. CEQA Requirements and the Imperial County’s Rules and Regulations for Implementing CEQA.....	1
C. Intended Uses of Initial Study and Notice of Preparation	2
D. Contents of Initial Study and Notice of Preparation	2
E. Scope of Environmental Analysis.....	3
F. Policy-Level or Project-Level Environmental Analysis	3
G. Tiered Documents and Incorporation by Reference	3
Environmental Checklist Form	1
Environmental Factors Potentially Affected	3
Environmental Evaluation Committee Determination	3
Project Summary.....	5
Project Location.....	5
Project Summary.....	5
Environmental Setting	5
General Plan Consistency.....	5
Evaluation of Environmental Impacts.....	8
I. Aesthetics	10
II. Agriculture and Forestry Resources.....	11
III. Air Quality	13
IV. Biological Resources.....	14
V. Cultural Resources.....	16
VI. Energy	17
VII. Geology and Soils	18
VIII. Greenhouse Gas Emissions	20
IX. Hazards and Hazardous Materials.....	21
X. Hydrology and Water Quality	23
XI. Land Use and Planning.....	25
XII. Mineral Resources	26
XIII. Noise	27
XIV. Population and Housing	28
XV. Public Services.....	29
XVI. Recreation	31
XVII. Transportation	32
XVIII. Tribal Cultural Resources.....	33
XIX. Utilities and Service Systems.....	34
XX. Wildfire	36
XXI. Mandatory Findings of Significance	38
References.....	39
List of Preparers.....	40



This page is intentionally blank.

PC ORIGINAL PKG



Introduction

A. Purpose

This document is a policy-level; project-level Initial Study for evaluation of potential environmental impacts resulting with the proposed VEGA SES 4 Solar Energy Project.

B. CEQA Requirements and the Imperial County's Rules and Regulations for Implementing CEQA

As defined by Section 15063 of the State California Environmental Quality Act (CEQA) Guidelines and Section 7 of the County's Rules and Regulations for Implementing CEQA, an **Initial Study** is prepared primarily to provide the Lead Agency with information to use as the basis for determining whether an Environmental Impact Report (EIR), Negative Declaration, or Mitigated Negative Declaration would be appropriate for providing the necessary environmental documentation and clearance for any proposed project.

- According to Section 15065, an **EIR** is deemed appropriate for a particular proposal if the following conditions occur:
 - The proposal has the potential to substantially degrade quality of the environment.
 - The proposal has the potential to achieve short-term environmental goals to the disadvantage of long-term environmental goals.
 - The proposal has possible environmental effects that are individually limited but cumulatively considerable.
 - The proposal could cause direct or indirect adverse effects on human beings.
- According to Section 15070(a), a **Negative Declaration** is deemed appropriate if the proposal would not result in any significant effect on the environment.
- According to Section 15070(b), a **Mitigated Negative Declaration** is deemed appropriate if it is determined that though a proposal could result in a significant effect, mitigation measures are available to reduce these significant effects to insignificant levels.

This Initial Study has determined that the proposed applications will result in potentially significant environmental impacts and therefore, an Environmental Impact Report is deemed as the appropriate document to provide necessary environmental evaluations and clearance for the proposed project.

This Initial Study and Notice of Preparation are prepared in conformance with the California Environmental Quality Act of 1970, as amended (Public Resources Code, Section 21000 et. seq.); the State CEQA Guidelines & County of Imperial's CEQA Regulations, Guidelines for the Implementation of CEQA; applicable requirements of the County of Imperial; and the regulations, requirements, and procedures of any other responsible public agency or an agency with jurisdiction by law.

Pursuant to the County of Imperial's CEQA Regulations, Guidelines for the Implementation of CEQA, depending on the project scope, the County of Imperial Board of Supervisors, Planning

Commission and/or Planning Director is designated the Lead Agency, in accordance with Section 15050 of the CEQA Guidelines. The Lead Agency is the public agency which has the principal responsibility for approving the necessary environmental clearances and analyses for any project in the County.

C. Intended Uses of Initial Study and Notice of Preparation

This Initial Study and Notice of Preparation are informational documents which are intended to inform County of Imperial decision makers, other responsible or interested agencies, and the general public of potential environmental effects of the proposed applications. The environmental review process has been established to enable public agencies to evaluate environmental consequences and to examine and implement methods of eliminating or reducing any potentially adverse impacts. While CEQA requires that consideration be given to avoiding environmental damage, the Lead Agency and other responsible public agencies must balance adverse environmental effects against other public objectives, including economic and social goals.

The Initial Study and Notice of Preparation, prepared for the project will be circulated for a period of no less than 35 days for public and agency review and comments.

D. Contents of Initial Study and Notice of Preparation

This Initial Study is organized to facilitate a basic understanding of the existing setting and environmental implications of the proposed applications.

SECTION 1

I. INTRODUCTION presents an introduction to the entire report. This section discusses the environmental process, scope of environmental review, and incorporation by reference documents.

SECTION 2

II. ENVIRONMENTAL CHECKLIST FORM contains the County's Environmental Checklist Form. The checklist form presents results of the environmental evaluation for the proposed applications and those issue areas that would have either a significant impact, potentially significant impact, or no impact.

PROJECT SUMMARY, LOCATION AND ENVIRONMENTAL SETTINGS describes the proposed project entitlements and required applications. A description of discretionary approvals and permits required for project implementation is also included. It also identifies the location of the project and a general description of the surrounding environmental settings.

ENVIRONMENTAL ANALYSIS evaluates each response provided in the environmental checklist form. Each response checked in the checklist form is discussed and supported with sufficient data and analysis as necessary. As appropriate, each response discussion describes and identifies specific impacts anticipated with project implementation.

SECTION 3

III. MANDATORY FINDINGS presents Mandatory Findings of Significance in accordance with Section 15065 of the CEQA Guidelines.



E. Scope of Environmental Analysis

For evaluation of environmental impacts, each question from the Environmental Checklist Form is summarized and responses are provided according to the analysis undertaken as part of the Initial Study. Impacts and effects will be evaluated and quantified, when appropriate. To each question, there are four possible responses, including:

1. No Impact: A “No Impact” response is adequately supported if the impact simply does not apply to the proposed applications.
2. Less Than Significant Impact: The proposed applications will have the potential to impact the environment. These impacts, however, will be less than significant; no additional analysis is required.
3. Less Than Significant With Mitigation Incorporated: This applies where incorporation of mitigation measures has reduced an effect from “Potentially Significant Impact” to a “Less Than Significant Impact.”
4. Potentially Significant Impact: The proposed applications could have impacts that are considered significant. Additional analyses and possibly an EIR could be required to identify mitigation measures that could reduce these impacts to less than significant levels.

F. Policy-Level or Project-Level Environmental Analysis

This Initial Study will be conducted under a policy-level, project-level analysis.

Regarding mitigation measures, it is not the intent of this document to “overlap” or restate conditions of approval that are commonly established for future known projects or the proposed applications. Additionally, those other standard requirements and regulations that any development must comply with, that are outside the County’s jurisdiction, are also not considered mitigation measures, and therefore, will not be identified in this document.

G. Tiered Documents and Incorporation by Reference

Information, findings, and conclusions contained in this document are based on incorporation by reference of tiered documentation, which are discussed in the following section.

1. Tiered Documents

As permitted in Section 15152(a) of the CEQA Guidelines, information and discussions from other documents can be included into this document. Tiering is defined as follows:

“Tiering refers to using the analysis of general matters contained in a broader EIR (such as the one prepared for a general plan or policy statement) with later EIRs and negative declarations on narrower projects; incorporating by reference the general discussions from the broader EIR; and concentrating the later EIR or negative declaration solely on the issues specific to the later project.”

Tiering also allows this document to comply with Section 15152(b) of the CEQA Guidelines, which discourages redundant analyses, as follows:

“Agencies are encouraged to tier the environmental analyses which they prepare for separate but related projects including the general plans, zoning changes, and development

projects. This approach can eliminate repetitive discussion of the same issues and focus the later EIR or negative declaration on the actual issues ripe for decision at each level of environmental review. Tiering is appropriate when the sequence of analysis is from an EIR prepared for a general plan, policy or program to an EIR or negative declaration for another plan, policy, or program of lesser scope, or to a site-specific EIR or negative declaration.”

Further, Section 15152(d) of the CEQA Guidelines states:

“Where an EIR has been prepared and certified for a program, plan, policy, or ordinance consistent with the requirements of this section, any lead agency for a later project pursuant to or consistent with the program, plan, policy, or ordinance should limit the EIR or negative declaration on the later project to effects which:

- (1) Were not examined as significant effects on the environment in the prior EIR; or
- (2) Are susceptible to substantial reduction or avoidance by the choice of specific revisions in the project, by the imposition of conditions, or other means.”

2. Incorporation by Reference

Incorporation by reference is a procedure for reducing the size of EIRs/MND and is most appropriate for including long, descriptive, or technical materials that provide general background information, but do not contribute directly to the specific analysis of the project itself. This procedure is particularly useful when an EIR or Negative Declaration relies on a broadly-drafted EIR for its evaluation of cumulative impacts of related projects (*Las Virgenes Homeowners Federation v. County of Los Angeles* [1986, 177 Ca.3d 300]). If an EIR or Negative Declaration relies on information from a supporting study that is available to the public, the EIR or Negative Declaration cannot be deemed unsupported by evidence or analysis (*San Francisco Ecology Center v. City and County of San Francisco* [1975, 48 Ca.3d 584, 595]).

When an EIR or Negative Declaration incorporates a document by reference, the incorporation must comply with Section 15150 of the CEQA Guidelines as follows:

- The incorporated document must be available to the public or be a matter of public record (CEQA Guidelines Section 15150[a]). The General Plan EIR is available, along with this document, at the County of Imperial Planning & Development Services Department, 801 Main Street, El Centro, CA 92243 Ph. (442) 265-1736.
- This document must be available for inspection by the public at an office of the lead agency (CEQA Guidelines Section 15150[b]). These documents are available at the County of Imperial Planning & Development Services Department, 801 Main Street, El Centro, CA 92243, Ph. (442) 265-1736.
- These documents must summarize the portion of the document being incorporated by reference or briefly describe information that cannot be summarized. Furthermore, these documents must describe the relationship between the incorporated information and the analysis in the tiered documents (CEQA Guidelines Section 15150[c]). As discussed above, the tiered EIRs address the entire project site and provide background and inventory information and data which apply to the project site. Incorporated information and/or data will be cited in the appropriate sections.



- These documents must include the State identification number of the incorporated documents (CEQA Guidelines Section 15150[d]). The State Clearinghouse Number for the 'County of Imperial General Plan EIR is SCH #93011023.

The material to be incorporated in this document will include general background information (CEQA Guidelines Section 15150[f])

PC ORIGINAL PKG

Environmental Checklist Form

1. **Project Title:** VEGA SES 4 Solar Energy Project
2. **Lead Agency name and address:** Imperial County Planning & Development Services
Department, 801 Main Street, El Centro, CA 92243
3. **Contact person and phone number:** Diana Robinson, Planner III, 442-265-1751
4. **Project location:** The project site is located on approximately 531 acres of privately-owned land in the southernmost portion of Imperial County, California. The project site is between the U.S./Mexico international border and the All-American Canal, on the California side (Figure 1). As depicted on Figure 2, the project site is on three parcels (Assessor Parcel Numbers 059-290-010, 059-300-015, and 059-300-017) that are contiguous with each other. It is approximately 10 miles east of the City of Calexico in Sections 10, 11, 14, 15, and 16 within Township 17 South, and Range 16 East of the San Bernardino Base and Meridian of the Bonds Corner topographic 7.5 minute quadrangle. As shown on Figure 1, the project site is located entirely within the County's Renewable Energy Overlay Zone.
5. **Project sponsor's name and address:** Apex Energy Solutions, LLC, 604 Sutter Street, Suite 250, Folsom, CA 95630
6. **General Plan Designation:** Agriculture
7. **Zoning:** A-3-RE (Heavy Agriculture with a Renewable Energy Zone Overlay)
8. **Description of project:** The proposed project consists of three primary components: 1) solar energy generation equipment and associated facilities including a substation and access roads (herein referred to as "solar energy facility"); 2) battery storage system; and, 3) gen-tie line that would connect the proposed on-site substation to the point of interconnection at the existing Imperial Irrigation District's 92-kV "P" line.

The proposed project involves the construction of a 100-megawatt (MW) alternating current (AC) photovoltaic (PV) solar energy facility with an integrated 100 MW battery storage system (not to exceed 200 MW) on approximately 531 acres of land. The project proposes to utilize either thin film or crystalline solar PV technology modules mounted either on fixed frames or horizontal single-axis tracker (HSAT) systems. The project would include electronic/electrical equipment, an on-site substation, access road(s) and fencing. The electrical energy produced by the project would be conducted through the project's interconnection facilities to the proposed 92 kV generator intertie (gen-tie) line and delivered to the existing IID approved point of interconnection on the 92-kV "P" Line.
9. **Surrounding land uses and setting: Briefly describe the project's surroundings:** The irregular shaped project site is bound by undeveloped land, portions of which have been disturbed associated with previous agricultural-related activities, to the west and east, the All-American Canal running southwest on the northern border of the project site, and the U.S./Mexico international border to the south. The project site is currently characterized by flat and undeveloped land, portions of which have been disturbed associated with previous agricultural-related activities.

10. Other public agencies whose approval is required (e.g., permits, financing approval, or participation agreement.):

- Department of Public Works – Ministerial permits (building, grading, encroachment)
- Imperial County Air Pollution Control District – Fugitive dust control plan, Authority to construct
- California Regional Water Quality Control Board – Notice of Intent for General Construction Permit
- Imperial Irrigation District – Water supply agreement/permit for water use lease agreement

11. Have California Native American tribes traditionally and culturally affiliated with the project area requested consultation pursuant to Public Resources Code section 21080.3.1? If so, is there a plan for consultation that includes, for example, the determination of significance of impacts to tribal cultural resources, procedures regarding confidentiality, etc.?

12. Yes, an AB 52 consultation request letter was sent to the Quechan Indian Tribe on March 26, 2021. On April 1, 2021, the Quechan Indian Tribe requested consultation with the County on the project.

Environmental Factors Potentially Affected

The environmental factors checked below would be potentially affected by this project, involving at least one impact that is a "Potentially Significant Impact" as indicated by the checklist on the following pages.

- | | | |
|---------------------------------------------------------------|------------------------------------------------------------------------|------------------------------------------------------------------------|
| <input checked="" type="checkbox"/> Aesthetics | <input checked="" type="checkbox"/> Agriculture and Forestry Resources | <input checked="" type="checkbox"/> Air Quality |
| <input checked="" type="checkbox"/> Biological Resources | <input checked="" type="checkbox"/> Cultural Resources | <input type="checkbox"/> Energy |
| <input checked="" type="checkbox"/> Geology/Soils | <input checked="" type="checkbox"/> Greenhouse Gas Emissions | <input type="checkbox"/> Hazards & Hazardous Materials |
| <input checked="" type="checkbox"/> Hydrology / Water Quality | <input type="checkbox"/> Land Use/Planning | <input type="checkbox"/> Mineral Resources |
| <input type="checkbox"/> Noise | <input type="checkbox"/> Population/Housing | <input checked="" type="checkbox"/> Public Services |
| <input type="checkbox"/> Recreation | <input checked="" type="checkbox"/> Transportation | <input checked="" type="checkbox"/> Tribal Cultural Resources |
| <input checked="" type="checkbox"/> Utilities/Service Systems | <input type="checkbox"/> Wildfire | <input checked="" type="checkbox"/> Mandatory Findings of Significance |

Environmental Evaluation Committee Determination

After Review of the Initial Study, the Environmental Evaluation Committee (EEC) has:

- Found that the proposed project COULD NOT have a significant effect on the environment, and a NEGATIVE DECLARATION will be prepared.
- Found that although the proposed project could have a significant effect on the environment, there will not be a significant effect in this case because revisions in the project have been made by or agreed to by the project proponent. A MITIGATED NEGATIVE DECLARATION will be prepared.
- Found that the proposed project MAY have a significant effect on the environment, and an ENVIRONMENTAL IMPACT REPORT is required.
- Found that the proposed project MAY have a "potentially significant impact" or "potentially significant unless mitigated" impact on the environment, but at least one effect 1) has been adequately analyzed in an earlier document pursuant to applicable legal standards, and 2) has been addressed by mitigation measures based on the earlier analysis as described on attached sheets. An ENVIRONMENTAL IMPACT REPORT is required, but it must analyze only the effects that remain to be addressed.
- Found that although the proposed project could have a significant effect on the environment, because all potentially significant effects (a) have been analyzed adequately in an earlier EIR or NEGATIVE DECLARATION pursuant to applicable standards, and (b) have been avoided or mitigated pursuant to that earlier EIR or NEGATIVE DECLARATION, including revisions or mitigation measures that are imposed upon the proposed project, nothing further is required.

CALIFORNIA DEPARTMENT OF FISH AND GAME DE MINIMIS IMPACT FINDING:

Yes No

EEC VOTES

	YES	NO	ABSENT
PUBLIC WORKS	<input type="checkbox"/>	<input type="checkbox"/>	<input type="checkbox"/>
ENVIRONMENTAL HEALTH	<input type="checkbox"/>	<input type="checkbox"/>	<input type="checkbox"/>
OFFICE EMERGENCY SERVICES	<input type="checkbox"/>	<input type="checkbox"/>	<input type="checkbox"/>
APCD	<input type="checkbox"/>	<input type="checkbox"/>	<input type="checkbox"/>
AG	<input type="checkbox"/>	<input type="checkbox"/>	<input type="checkbox"/>
SHERIFF DEPARTMENT	<input type="checkbox"/>	<input type="checkbox"/>	<input type="checkbox"/>
ICPDS	<input type="checkbox"/>	<input type="checkbox"/>	<input type="checkbox"/>

Jim Minnick, Director of Planning/EEC Chairman

Signature

Date:

Project Summary

Project Location

The project site is located on approximately 531 acres of privately-owned land in the southernmost portion of Imperial County, California. The project site is between the U.S./Mexico international border and the All-American Canal, on the California side (Figure 1). As depicted on Figure 2, the project site is on three parcels (Assessor Parcel Numbers 059-290-010, 059-300-015, and 059-300-017) that are contiguous with each other. It is approximately 10 miles east of the City of Calexico in Sections 10, 11, 14, 15, and 16 within Township 17 South, and Range 16 East of the San Bernardino Base and Meridian of the Bonds Corner topographic 7.5 minute quadrangle. As shown on Figure 1, the project site is located entirely within the County’s Renewable Energy Overlay Zone.

Project Summary

The proposed project consists of three primary components: 1) solar energy generation equipment and associated facilities including a substation and access roads (herein referred to as “solar energy facility”); 2) battery storage system; and, 3) gen-tie line that would connect the proposed on-site substation to the point of interconnection at the existing Imperial Irrigation District’s 92-kV “P” line.

The proposed project involves the construction of a 100-megawatt (MW) alternating current (AC) photovoltaic (PV) solar energy facility with an integrated 100 MW battery storage system (not to exceed 200 MW) on approximately 531 acres of land. The project proposes to utilize either thin film or crystalline solar PV technology modules mounted either on fixed frames or horizontal single-axis tracker (HSAT) systems. The project would include electronic/electrical equipment, an on-site substation, access road(s) and fencing. The electrical energy produced by the project would be conducted through the project’s interconnection facilities to the proposed 92 kV generator intertie (gen-tie) line and delivered to the existing IID approved point of interconnection on the 92-kV “P” Line.

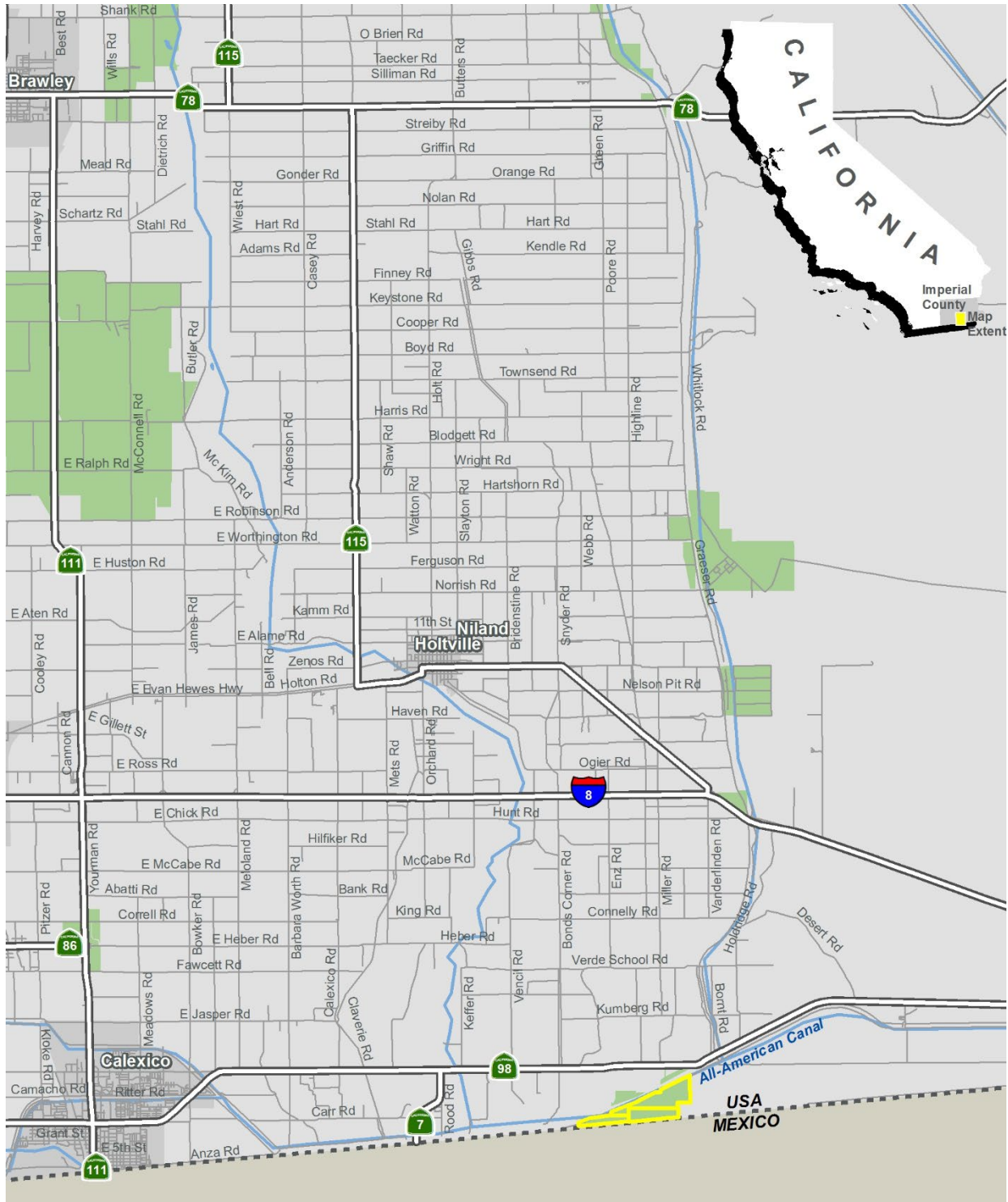
Environmental Setting

The irregular shaped project site is bound by undeveloped land, portions of which have been disturbed associated with previous agricultural-related activities to the west and east, the All-American Canal running southwest on the northern border of the project site, and the U.S./Mexico international border to the south. The project site is currently characterized by flat and undeveloped land, portions of which have been disturbed associated with previous agricultural-related activities.

General Plan Consistency

The proposed project is located within an unincorporated area of the County. The existing General Plan land use designation is “Agriculture.” The project site is currently zoned A-3-RE (Heavy Agriculture with a Renewable Energy Zone Overlay). Construction of a solar facility would be allowed within the existing zoning under a Conditional Use Permit.

Figure 1. Regional Location



LEGEND



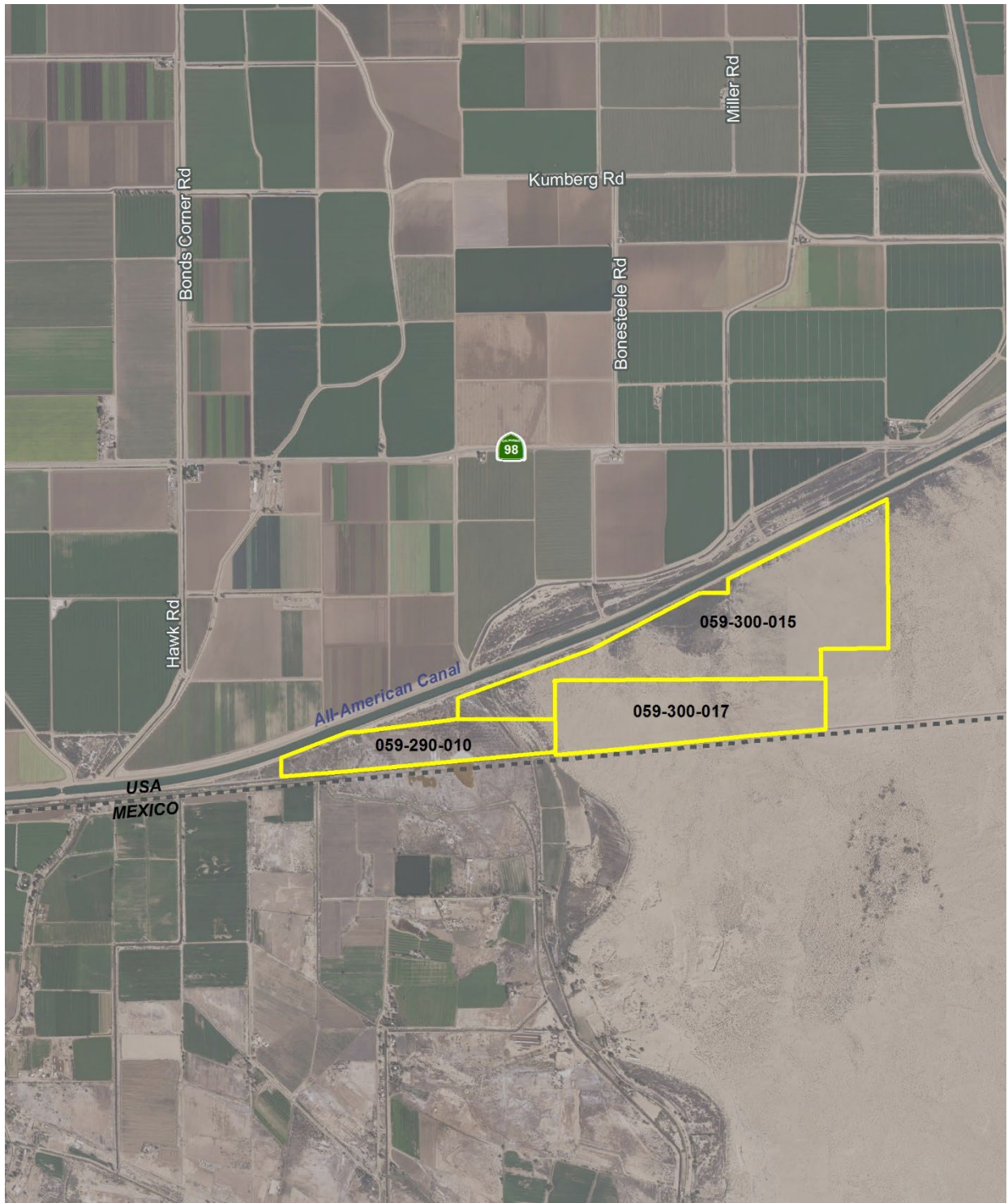
-  VEGA SES 4 Project Area
-  Renewable Energy Overlay Zone



Figure 2. Project Site



Legend

 VEGA SES 4 Project Parcels



0 Feet 2,000

Evaluation of Environmental Impacts

1. A brief explanation is required for all answers except "No Impact" answers that are adequately supported by the information sources a lead agency cites in the parentheses following each question. A "No Impact" answer is adequately supported if the referenced information sources show that the impact simply does not apply to projects like the one involved (e.g., the project falls outside a fault rupture zone). A "No Impact" answer should be explained where it is based on project-specific factors, as well as general standards (e.g., the project will not expose sensitive receptors to pollutants, based on a project-specific screening analysis).
2. All answers must take account of the whole action involved, including off-site as well as on-site, cumulative as well as project-level, indirect as well as direct, and construction as well as operational impacts.
3. Once the lead agency has determined that a particular physical impact may occur, then the checklist answers must indicate whether the impact is potentially significant, less than significant with mitigation, or less than significant. "Potentially Significant Impact" is appropriate if there is substantial evidence that an effect may be significant. If there are one or more "Potentially Significant Impact" entries when the determination is made, an EIR is required.
4. "Negative Declaration: Less Than Significant With Mitigation Incorporated" applies where the incorporation of mitigation measures has reduced an effect from "Potentially Significant Impact" to a "Less Than Significant Impact." The lead agency must describe the mitigation measures, and briefly explain how they reduce the effect to a less than significant level (mitigation measures from "Earlier Analyses," as described in (5) below, may be cross-referenced).
5. Earlier analyses may be used where, pursuant to the tiering, program EIR, or other CEQA process, an effect has been adequately analyzed in an earlier EIR or negative declaration. Section 15063(c)(3)(D). In this case, a brief discussion should identify the following:
 - a. Earlier Analysis Used. Identify and state where they are available for review.
 - b. Impacts Adequately Addressed. Identify which effects from the above checklist were within the scope of and adequately analyzed in an earlier document pursuant to applicable legal standards, and state whether such effects were addressed by mitigation measures based on the earlier analysis.
 - c. Mitigation Measures. For effects that are "Less than Significant with Mitigation Measures Incorporated," describe the mitigation measures which were incorporated or refined from the earlier document and the extent to which they address site-specific conditions for the project.

6. Lead agencies are encouraged to incorporate into the checklist references to information sources for potential impacts (e.g., general plans, zoning ordinances). Reference to a previously prepared or outside document should, where appropriate, include a reference to the page or pages where the statement is substantiated.
7. Supporting Information Sources: A source list should be attached, and other sources used, or individuals contacted should be cited in the discussion.
8. This is only a suggested form, and lead agencies are free to use different formats; however, lead agencies should normally address the questions from this checklist that are relevant to a project's environmental effects in whatever format is selected.
9. The explanation of each issue should identify:
 - a. The significance criteria or threshold, if any, used to evaluate each question; and
 - b. The mitigation measure identified, if any, to reduce the impact to less than significance.

I. Aesthetics

Environmental Issue Area:	Potentially Significant Impact	Potentially Significant Unless Mitigation Incorporated	Less Than Significant Impact	No Impact
Except as provided in Public Resources Code Section 21099, would the project:				
a) Have a substantial adverse effect on a scenic vista?	<input type="checkbox"/>	<input type="checkbox"/>	<input type="checkbox"/>	<input checked="" type="checkbox"/>
b) Substantially damage scenic resources, including, but not limited to, trees, rock outcroppings, and historic building within a state scenic highway?	<input type="checkbox"/>	<input type="checkbox"/>	<input type="checkbox"/>	<input checked="" type="checkbox"/>
c) In non-urbanized areas, substantially degrade the existing visual character or quality of public views of the site and its surroundings? (Public views are those that are experienced from publicly accessible vantage points). If the project is in an urbanized area, would the project conflict with applicable zoning and other regulations governing scenic quality?	<input checked="" type="checkbox"/>	<input type="checkbox"/>	<input type="checkbox"/>	<input type="checkbox"/>
d) Create a new source of substantial light or glare which would adversely affect day or nighttime views in the area?	<input checked="" type="checkbox"/>	<input type="checkbox"/>	<input type="checkbox"/>	<input type="checkbox"/>

Impact Analysis

- a) **No Impact.** The project site is not located within an area that has been formally identified as a federal, state, or county scenic vista. No scenic vistas or areas with high visual quality would be disrupted. Thus, no impact is identified for this issue area and no further analysis is warranted.
- b) **No Impact.** According to the California Department of Transportation (Caltrans) California Scenic Highway Mapping System (Caltrans 2018), the project site is not located within a state scenic highway corridor, nor are there any state scenic highways located in proximity to the project site. The proposed project would not substantially damage scenic resources, including, but not limited to, trees, rock outcroppings, and historic building within a state scenic highway. Therefore, no impact is identified for this issue area and no further analysis is warranted.
- c) **Potentially Significant Impact.** Although the project site is not located near a scenic highway or designated scenic vista, the proposed project may result in a change to the look and rural character of the area. Therefore, a potentially significant impact is identified for this issue area. A visual assessment will be prepared for the project and this issue will be addressed in the EIR.
- d) **Potentially Significant Impact.** Minimal lighting is required for project operation and is limited to safety and security functions. All lighting will be directed away from any public right-of-way; however, there is no heavily traveled public roadway in immediate proximity to the project site. The solar panels will be constructed of low reflective materials; therefore, it is not anticipated that they would result in creating glare. The proposed project is located in a rural undeveloped area of Imperial County. There are no established residential neighborhoods immediately adjacent to the project site. Although the proposed project is not expected to create a new source of substantial light or glare affecting day or nighttime views, this issue will be analyzed further in the EIR. Therefore, a potentially significant impact is identified for this issue area.

II. Agriculture and Forestry Resources

Environmental Issue Area:	Potentially Significant Impact	Potentially Significant Unless Mitigation Incorporated	Less Than Significant Impact	No Impact
<p><i>In determining whether impacts to agricultural resources are significant environmental effects, lead agencies may refer to the California Agricultural Land Evaluation and Site Assessment Model (1997) prepared by the California Department of Conservation as an optional model to use in assessing impacts on agriculture and farmland. In determining whether impacts to forest resources, including timberland, are significant environmental effects, lead agencies may refer to information compiled by the California Department of Forestry and Fire Protection regarding the state's inventory of forest land, including the Forest and Range Assessment Project and the Forest Legacy Assessment project; and forest carbon measurement methodology provided in Forest Protocols adopted by the California Air Resources Board.</i></p> <p>Would the project:</p>				
a) Convert Prime Farmland, Unique Farmland, or Farmland of Statewide Importance (Farmland), as shown on the maps prepared pursuant to the Farmland Mapping and Monitoring Program of the California Resources Agency, to non-agricultural use?	<input type="checkbox"/>	<input type="checkbox"/>	<input type="checkbox"/>	<input checked="" type="checkbox"/>
b) Conflict with existing zoning for agricultural use, or a Williamson Act contract?	<input checked="" type="checkbox"/>	<input type="checkbox"/>	<input type="checkbox"/>	<input type="checkbox"/>
c) Conflict with existing zoning for, or cause rezoning of, forest land (as defined in Public Resources Code section 12220(g)), timberland (as defined by Public Resources Code section 4526), or timberland zoned Timberland Production (as defined by Government Code section 51104(g))?	<input type="checkbox"/>	<input type="checkbox"/>	<input type="checkbox"/>	<input checked="" type="checkbox"/>
d) Result in the loss of forest land or conversion of forest land to non-forest use?	<input type="checkbox"/>	<input type="checkbox"/>	<input type="checkbox"/>	<input checked="" type="checkbox"/>
e) Involve other changes in the existing environment which, due to their location or nature, could result in conversion of Farmland, to non-agricultural use or conversion of forest land to non-forest use?	<input type="checkbox"/>	<input type="checkbox"/>	<input type="checkbox"/>	<input checked="" type="checkbox"/>

Impact Analysis

- a) **No Impact.** According to the farmland maps prepared by the California Department of Conservation (2016), the majority of the project site is designated as Other Land. A portion of the project site is designated as Farmland of Local Importance. Farmland of Local Importance is not considered an “agricultural land” per CEQA Statute Section 21060.1(a). Furthermore, the project site does not contain Prime Farmland, Farmland of Statewide Importance, or Unique Farmland. Therefore, no impact would result from the conversion of Prime Farmland, Farmland of Statewide Importance, or Unique Farmland to non-agricultural use.

- b) **Potentially Significant Impact.** The project site is currently designated by the General Plan as “Agriculture” and is zoned A-3-RE (Heavy Agriculture with a Renewable Energy Zone Overlay). Pursuant to Title 9, Division 5, Chapter 9, “Solar Energy Plants” and “Transmission lines, including supporting towers, poles microwave towers, utility substations” are uses that are permitted in the A-3 Zone, subject to approval of a CUP. Because the project site is located on lands designated for agricultural uses, this issue will be analyzed in further detail in the EIR.

According to the 2016/2017 Imperial County Williamson Act Map produced by the California Department of Conservation’s Division of Land Resource Protection, the project site is not located on Williamson Act contracted land. Therefore, the proposed project would not conflict with a Williamson Act contract and no impact would occur.

- c) **No Impact.** There are no existing forest lands, timberlands, or timberland zoned “Timberland Production” within or immediately adjacent to the project site that would conflict with existing zoning or cause rezoning. Therefore, no impact is identified for this issue area.
- d) **No Impact.** There are no existing forest lands within or immediately adjacent to the project site. The proposed project would not result in the loss of forest land or conversion of forest land to non-forest use. Therefore, no impact is identified for this issue area.
- e) **No Impact.** Refer to response II. a) above.

III. Air Quality

Environmental Issue Area:	Potentially Significant Impact	Potentially Significant Unless Mitigation Incorporated	Less Than Significant Impact	No Impact
<i>Where available, the significance criteria established by the applicable air quality management district or air pollution control district may be relied upon to make the following determinations.</i>				
<i>Would the project:</i>				
a) Conflict with or obstruct implementation of the applicable air quality plan?	<input checked="" type="checkbox"/>	<input type="checkbox"/>	<input type="checkbox"/>	<input type="checkbox"/>
b) Result in a cumulatively considerable net increase of any criteria pollutant for which the project region is non-attainment under an applicable federal or state ambient air quality standard?	<input checked="" type="checkbox"/>	<input type="checkbox"/>	<input type="checkbox"/>	<input type="checkbox"/>
c) Expose sensitive receptors to substantial pollutant concentrations?	<input checked="" type="checkbox"/>	<input type="checkbox"/>	<input type="checkbox"/>	<input type="checkbox"/>
d) Result in other emissions (such as those leading to odors adversely affecting a substantial number of people)?	<input type="checkbox"/>	<input type="checkbox"/>	<input type="checkbox"/>	<input checked="" type="checkbox"/>

Impact Analysis

- a) **Potentially Significant Impact.** The project site is located within the jurisdiction of Imperial County Air Pollution Control District (ICAPCD) in the Imperial County portion of the Salton Sea Air Basin. Construction of the proposed project would create temporary emissions of dust, fumes, equipment exhaust, and other air contaminants that may conflict with the ICAPCD’s rules and regulations. No stationary source emissions are proposed from the proposed project; however, temporary construction emissions have the potential to result in a significant air quality impact.
- b) **Potentially Significant Impact.** Currently, the Salton Sea Air Basin is either in attainment or unclassified for all federal and state air pollutant standards, with the exception of the federal ozone (O₃), particulate matter less than 10 microns in diameter (PM₁₀) and particulate matter less than 2.5 microns in diameter (PM_{2.5}) standards, and state standards for O₃ and PM₁₀. Air pollutants transported into the Salton Sea Air Basin from the adjacent South Coast Air Basin (Los Angeles County, San Bernardino County, Orange County, and Riverside County) and Mexicali (Mexico) substantially contribute to the non-attainment conditions in the Salton Sea Air Basin. A potentially significant impact is identified for this issue area. An air quality and greenhouse gas study will be prepared to analyze the proposed project’s potential air quality impacts and will be included in the EIR analysis.
- c) **Potentially Significant Impact.** The project site is located in a rural agricultural area of Imperial County. Sensitive receptors consisting of a few scattered rural homes along SR-98 are located within one mile north of the project site. This issue will be addressed in the air quality and greenhouse gas study and EIR analysis.
- d) **No Impact.** Land uses commonly considered to be potential sources of odorous emissions include wastewater treatment plants, sanitary landfills, food processing facilities, chemical manufacturing plants, rendering plants, paint/coating operations, and concentrated agricultural feeding operations and dairies. The construction and operation of a solar facility is not an odor producer and the project site is not located near an odor producer. Therefore, no impact is identified for this issue area.

IV. Biological Resources

Environmental Issue Area:	Potentially Significant Impact	Potentially Significant Unless Mitigation Incorporated	Less Than Significant Impact	No Impact
Would the project:				
a) Have a substantial adverse effect, either directly or through habitat modifications, on any species identified as a candidate, sensitive, or special status species in local or regional plans, policies, or regulations, or by the California Department of Fish and Game or U.S. Fish and Wildlife Service?	<input checked="" type="checkbox"/>	<input type="checkbox"/>	<input type="checkbox"/>	<input type="checkbox"/>
b) Have a substantial adverse effect on any riparian habitat or other sensitive natural community identified in local or regional plans, policies, and regulations or by the California Department of Fish and Game or U.S. Fish and Wildlife Service?	<input checked="" type="checkbox"/>	<input type="checkbox"/>	<input type="checkbox"/>	<input type="checkbox"/>
c) Have a substantial adverse effect on state or federally protected wetlands (including, but not limited to, marsh, vernal pool, coastal, etc.) through direct removal, filling, hydrological interruption, or other means?	<input checked="" type="checkbox"/>	<input type="checkbox"/>	<input type="checkbox"/>	<input type="checkbox"/>
d) Interfere substantially with the movement of any native resident or migratory fish or wildlife species or with established native resident or migratory wildlife corridors, or impede the use of wildlife nursery sites?	<input checked="" type="checkbox"/>	<input type="checkbox"/>	<input type="checkbox"/>	<input type="checkbox"/>
e) Conflict with any local policies or ordinances protecting biological resources, such as a tree preservation policy or ordinance?	<input checked="" type="checkbox"/>	<input type="checkbox"/>	<input type="checkbox"/>	<input type="checkbox"/>
f) Conflict with the provisions of an adopted Habitat Conservation Plan, Natural Community Conservation Plan, or other approved local, regional, or state habitat conservation plan?	<input type="checkbox"/>	<input type="checkbox"/>	<input type="checkbox"/>	<input checked="" type="checkbox"/>

Impact Analysis

- a) **Potentially Significant Impact.** According to the Conservation and Open Space Element of the General Plan (County of Imperial 2016), numerous special-status species occur in the County of Imperial, and of particular concern are the western burrowing owl and flat-tailed horned lizard which may have the potential to occur within the project site. The project site has the potential to support native habitats and/or sensitive species. Burrowing owls and burrows are commonly found along canals and drains. Although there are no IID canals located within the project site, access roads, canals, and other drainages are located in the project vicinity, such as the All American Canal immediately north of the proposed project. Thus, a potentially

significant impact is identified for this issue area. A biological resources technical study that will address the proposed project's potential impacts on biological resources will be prepared and included in the EIR analysis.

- b) **Potentially Significant Impact.** Refer to response IV. a) above.
- c) **Potentially Significant Impact.** According to the National Wetlands Inventory, there are two wetland features mapped within the project site. An aquatic resources delineation that will address the proposed project's potential impacts on state or federally protected wetlands will be prepared and included in the EIR analysis.
- d) **Potentially Significant Impact.** Refer to response IV. a) above.
- e) **Potentially Significant Impact.** Refer to response IV. a) above.
- f) **No Impact.** The project site is not located in a Habitat Conservation Plan, Natural Community Conservation Plan, or other approved local, regional, or state habitat conservation plan. No impact is identified for this issue area.

V. Cultural Resources

Environmental Issue Area:	Potentially Significant Impact	Potentially Significant Unless Mitigation Incorporated	Less Than Significant Impact	No Impact
Would the project:				
a) Cause a substantial adverse change in the significance of a historical resource pursuant to §15064.5?	<input checked="" type="checkbox"/>	<input type="checkbox"/>	<input type="checkbox"/>	<input type="checkbox"/>
b) Cause a substantial adverse change in the significance of an archaeological resource pursuant to §15064.5?	<input checked="" type="checkbox"/>	<input type="checkbox"/>	<input type="checkbox"/>	<input type="checkbox"/>
c) Disturb any human remains, including those interred outside of dedicated cemeteries?	<input checked="" type="checkbox"/>	<input type="checkbox"/>	<input type="checkbox"/>	<input type="checkbox"/>

Impact Analysis

- a) **Potentially Significant Impact.** The project site consists of undeveloped land that appears to have been historically altered. The disturbed nature of the site, including the existence of old agricultural-use related foundations and farming equipment including an irrigation system, indicates that portions of the land may have been historically used for agricultural purposes. Thus, the presence of significant or undamaged cultural resources on the site is unlikely. Although the proposed project is not expected to cause a substantial adverse change in the significance of a historical resource or archaeological resource, this issue will be analyzed further in the EIR. Therefore, a potentially significant impact is identified for this issue area. A cultural resources report that will address the proposed project's potential impacts on historic and prehistoric resources will be prepared and this issue will be addressed in the EIR.
- b) **Potentially Significant Impact.** Refer to response V. a) above.
- c) **Potentially Significant Impact.** Although unlikely, there is a potential for unknown human remains to be unearthed during earthwork activities. This issue is potentially significant and will be addressed in the EIR.

VI. Energy

Environmental Issue Area:	Potentially Significant Impact	Potentially Significant Unless Mitigation Incorporated	Less Than Significant Impact	No Impact
Would the project:				
a) Result in potentially significant environmental impact due to wasteful, inefficient, or unnecessary consumption of energy resources, during project construction or operation?	<input type="checkbox"/>	<input type="checkbox"/>	<input checked="" type="checkbox"/>	<input type="checkbox"/>
b) Conflict with or obstruct a state or local plan for renewable energy or energy efficiency?	<input type="checkbox"/>	<input type="checkbox"/>	<input type="checkbox"/>	<input checked="" type="checkbox"/>

Impact Analysis

- a) **Less than Significant Impact.** The use of energy associated with the proposed project includes both construction and operational activities. Construction activities consume energy through the use of heavy construction equipment and truck and worker traffic. The proposed project will use energy-conserving construction equipment, including standards for construction combustion equipment recommended in the ICAPCD CEQA Air Quality Handbook. The use of better engine technology, in conjunction with the ICAPCD's standards will reduce the amount of energy used for the proposed project. Additionally, implementation and operation of the proposed project would promote the use of renewable energy and contribute incrementally to the reduction in demand for fossil fuel use for electricity-generating purposes. Therefore, the proposed project would generate renewable energy resources and is considered a beneficial effect.

Based on these considerations, the proposed project would not result in significant environmental impacts due to wasteful, inefficient, or unnecessary consumption of energy resources during construction or operation. A less than significant impact has been identified for this issue area.

- b) **No Impact.** The proposed project would help California meet its Renewable Portfolio Standard of 60 percent of retail electricity sales from renewable sources by the end of 2030 and 100 percent by 2045. The electricity generation process associated with the project would utilize solar technology to convert sunlight directly into electricity. Solar PV technology is consistent with the definition of an "eligible renewable energy resource" in Section 399.12 of the California Public Utilities Code (CPUC) and the definition of "in-state renewable electricity generation facility" in Section 25741 of the CPUC. Therefore, the proposed project would not conflict with or obstruct a state or local plan for renewable energy or energy efficiency. No Impact is identified for this issue area and no further analysis is warranted.

VII. Geology and Soils

Environmental Issue Area:	Potentially Significant Impact	Potentially Significant Unless Mitigation Incorporated	Less Than Significant Impact	No Impact
Would the project:				
a) Directly or indirectly cause potential substantial adverse effects, including the risk of loss, injury or death involving:				
i. Rupture of a known earthquake fault, as delineated on the most recent Alquist-Priolo Earthquake Fault Zoning Map issued by the State Geologist for the area or based on other substantial evidence of a known fault? Refer to Division of Mines and Geology Special Publication 42?	<input type="checkbox"/>	<input type="checkbox"/>	<input type="checkbox"/>	<input checked="" type="checkbox"/>
ii. Strong seismic ground shaking?	<input checked="" type="checkbox"/>	<input type="checkbox"/>	<input type="checkbox"/>	<input type="checkbox"/>
iii. Seismic-related ground failure, including liquefaction?	<input checked="" type="checkbox"/>	<input type="checkbox"/>	<input type="checkbox"/>	<input type="checkbox"/>
iv. Landslides?	<input type="checkbox"/>	<input type="checkbox"/>	<input type="checkbox"/>	<input checked="" type="checkbox"/>
b) Result in substantial soil erosion or the loss of topsoil?	<input type="checkbox"/>	<input type="checkbox"/>	<input checked="" type="checkbox"/>	<input type="checkbox"/>
c) Be located on a geologic unit or soil that is unstable, or that would become unstable as a result of the project and potentially result in on- or off-site landslide, lateral spreading, subsidence, liquefaction, or collapse?	<input checked="" type="checkbox"/>	<input type="checkbox"/>	<input type="checkbox"/>	<input type="checkbox"/>
d) Be located on expansive soil, as defined in Table 18-1B of the Uniform Building Code (1994), creating substantial direct or indirect risk to life or property?	<input checked="" type="checkbox"/>	<input type="checkbox"/>	<input type="checkbox"/>	<input type="checkbox"/>
e) Have soils incapable of adequately supporting the use of septic tanks or alternative wastewater disposal systems where sewers are not available for the disposal of wastewater?	<input type="checkbox"/>	<input type="checkbox"/>	<input type="checkbox"/>	<input checked="" type="checkbox"/>
f) Directly or indirectly destroy a unique paleontological resource or site or unique geologic feature?	<input checked="" type="checkbox"/>	<input type="checkbox"/>	<input type="checkbox"/>	<input type="checkbox"/>

Impact Analysis

- ai) **No Impact.** The project site is not located within a State of California, Alquist-Priolo Earthquake Fault Zone. Therefore, no impact is identified for this issue area.
- a ii) **Potentially Significant Impact.** The project site is located in the seismically-active Imperial Valley in Southern California and considered likely to be subjected to moderate to strong ground motion from earthquakes in the region. The project site could be affected by the occurrence of seismic activity to some degree but no more than the surrounding properties. A potentially significant impact has been identified for this issue area. A geotechnical report that will address the proposed project's potential impacts on geology and soils will be prepared and this issue will be addressed in the EIR.
- a iii) **Potentially Significant Impact.** Liquefaction occurs when granular soil below the water table is subjected to vibratory motions, such as vibratory motion produced by earthquakes. With strong ground shaking, an increase in pore water pressure develops as the soil tends to reduce in volume. If the increase in pore water pressure is sufficient to reduce the vertical effective stress (suspending the soil particles in water), the soil strength decreases, and the soil behaves as a liquid (similar to quicksand). Liquefaction can produce excessive settlement, ground rupture, lateral spreading, or failure of shallow bearing foundations.

Four conditions are generally required for liquefaction to occur:

- 1) The soil must be saturated (relatively shallow groundwater).
- 2) The soil must be loosely packed (low to medium relative density).
- 3) The soil must be relatively cohesionless (not clayey).
- 4) Groundshaking of sufficient intensity must occur to function as a trigger mechanism.

All these conditions may exist to some degree at the project site. Therefore, there is a potentially significant impact associated with liquefaction. A geotechnical report that will address the proposed project's potential impacts on geology and soils will be prepared and this issue will be addressed in the EIR.

- a iv) **No Impact.** According to Figure 2: Landslide Activity in the Seismic and Public Safety Element of the General Plan (County of Imperial 1997), the project site is not located in an area that is prone to landslide hazards. Furthermore, the project site and surrounding area is relatively flat. Therefore, no impact is identified for this issue area.
- b) **Less than Significant Impact.** According to Figure 3: Erosion Activity in the Soil the Seismic and Public Safety Element of the General Plan (County of Imperial 1997), the project site is within a generally flat area with low levels of natural erosion. However, soil erosion can result during construction as grading and construction can loosen surface soils and make soils susceptible to wind and water movement across the surface. Impacts are not considered significant because erosion would be controlled on-site in accordance with Imperial County standards including preparation, review, and approval of a grading plan by the Imperial County Engineer. Implementation of Imperial County standards would reduce the potential impacts to a less than significant level.
- c) **Potentially Significant Impact.** Near surface soils within the project site will need to be identified to determine if the soils are unstable. Therefore, this issue is potentially significant and will be analyzed in the EIR.
- d) **Potentially Significant Impact.** Near surface soils within the project site will need to be identified to determine if they consist of soils having expansion potential. Therefore, this issue is potentially significant and will be analyzed in the EIR.
- e) **No Impact.** The proposed project would not require the installation of septic tanks or alternative wastewater disposal systems. The proposed solar facility would be remotely operated, controlled and monitored and with no requirement for daily on-site employees. Therefore, no impact is identified for this issue area.
- f) **Potentially Significant Impact.** Many paleontological fossil sites are recorded in Imperial County and have been discovered during construction activities. Paleontological resources are typically impacted when earthwork activities, such as mass excavation cut into geological deposits (formations) with buried fossils. It is not known if any paleontological resources are located on the project site. The proposed project's potential to impact paleontological resources will be addressed in the EIR.

VIII. Greenhouse Gas Emissions

Environmental Issue Area:	Potentially Significant Impact	Potentially Significant Unless Mitigation Incorporated	Less Than Significant Impact	No Impact
Would the project:				
a) Generate greenhouse gas emissions, either directly or indirectly, that may have a significant impact on the environment?	<input checked="" type="checkbox"/>	<input type="checkbox"/>	<input type="checkbox"/>	<input type="checkbox"/>
b) Conflict with an applicable plan, policy, or regulation adopted for the purpose of reducing the emissions of greenhouse gases?	<input checked="" type="checkbox"/>	<input type="checkbox"/>	<input type="checkbox"/>	<input type="checkbox"/>

Impact Analysis

- a) **Potentially Significant Impact.** In the long-term, the project is expected to provide a benefit with respect to reduction of greenhouse gas emissions. However, the proposed project has the potential to generate greenhouse gas emissions during construction, in addition to construction worker trips to and from the project site. Thus, a potentially significant impact is identified for this issue area. A greenhouse gas emissions/climate change technical report will be prepared for the proposed project, and this issue will be addressed in the EIR.
- b) **Potentially Significant Impact.** Refer to response VIII. a) above.

IX. Hazards and Hazardous Materials

Environmental Issue Area:	Potentially Significant Impact	Potentially Significant Unless Mitigation Incorporated	Less Than Significant Impact	No Impact
Would the project:				
a) Create a significant hazard to the public or the environment through the routine transport, use, or disposal of hazardous materials?	<input type="checkbox"/>	<input type="checkbox"/>	<input checked="" type="checkbox"/>	<input type="checkbox"/>
b) Create a significant hazard to the public or the environment through reasonably foreseeable upset and accident conditions involving the likely release of hazardous materials into the environment?	<input type="checkbox"/>	<input type="checkbox"/>	<input checked="" type="checkbox"/>	<input type="checkbox"/>
c) Emit hazardous emissions or handle hazardous or acutely hazardous materials, substances, or waste within one-quarter mile of an existing or proposed school?	<input type="checkbox"/>	<input type="checkbox"/>	<input type="checkbox"/>	<input checked="" type="checkbox"/>
d) Be located on a site which is included on a list of hazardous materials sites compiled pursuant to Government Code Section 65962.5 and, as a result, would it create a significant hazard to the public or the environment?	<input type="checkbox"/>	<input type="checkbox"/>	<input type="checkbox"/>	<input checked="" type="checkbox"/>
e) For a project located within an airport land use plan or, where such a plan has not been adopted, within two miles of a public airport or public use airport, would the project result in a safety hazard or excessive noise for people residing or working in the project area?	<input type="checkbox"/>	<input type="checkbox"/>	<input type="checkbox"/>	<input checked="" type="checkbox"/>
f) Impair implementation of or physically interfere with an adopted emergency response plan or emergency evacuation plan?	<input type="checkbox"/>	<input type="checkbox"/>	<input checked="" type="checkbox"/>	<input type="checkbox"/>
g) Expose people or structures, either directly or indirectly, to a significant risk of loss, injury, or death involving wildland fires?	<input type="checkbox"/>	<input type="checkbox"/>	<input checked="" type="checkbox"/>	<input type="checkbox"/>

Impact Analysis

- a) **Less than Significant Impact.** Construction of the proposed project will involve the limited use of hazardous materials, such as fuels and greases to fuel and service construction equipment. No extremely hazardous substances are anticipated to be produced, used, stored, transported, or disposed of as a result of project construction. Operation of the project will be conducted remotely. Therefore, no habitable structures (e.g. housing or operation and maintenance [O&M] building) are proposed on-site. Regular and routine maintenance of the proposed project may result in the potential to handle hazardous materials. However, the hazardous materials handled on-site would be limited to small amounts of everyday use cleaners and common chemicals used for maintenance. The applicant will be required to comply with State

laws and County Ordinance restrictions, which regulate and control hazardous materials handled on-site. Such hazardous wastes would be transported off-site for disposal according to applicable State and County restrictions and laws governing the disposal of hazardous waste during construction and operation of the project. Therefore, this is considered a less than significant impact.

- b) **Less than Significant Impact.** Refer to response IX. a) above.
- c) **No Impact.** The project site is not located within 0.25 mile of an existing or proposed school. No impact is identified for this issue area.
- d) **No Impact.** Based on a review of the Cortese List conducted in March 2021, the project site is not listed as a hazardous materials site. No impact is identified for this issue area.
- e) **No Impact.** The project site is not located within 2 miles of a public airport. The nearest airports to the project site are the Calexico International Airport located approximately 10 miles west of the project site and Holtville Airport located approximately 10 miles north of the project site. Therefore, implementation of the proposed project would not result in a safety hazard or excessive noise for people residing or working in the project area. No impact is identified for this issue area.
- f) **Less than Significant Impact.** The proposed project is not expected to impair implementation of or physically interfere with an adopted emergency response plan or emergency evacuation plan. The project applicant will be required, through the conditions of approval, to prepare a street improvement plan for the project that will include emergency access points and safe vehicular travel. In addition, local building codes would be followed to minimize flood, seismic, and fire hazard. Therefore, the proposed project would result in a less than significant impact associated with the possible impediment to emergency plans.
- g) **Less than Significant Impact.** The project site is located in the unincorporated area of Imperial County. According to the Seismic and Public Safety Element of the General Plan (County of Imperial 1997), the potential for a major fire in the unincorporated areas of the County is generally low. A 10,000-gallon aboveground water storage tank will be installed on-site as required by the Imperial County Fire Department. The water tank(s) would be sized to meet the requirements of the County of Imperial to supply sufficient fire suppression water during operations. Furthermore, proposed project facilities would be designed, constructed, and operated in accordance with applicable fire protection and other environmental, health, and safety requirements. Based on these considerations, a less than significant impact is identified for this issue area.

X. Hydrology and Water Quality

Environmental Issue Area:	Potentially Significant Impact	Potentially Significant Unless Mitigation Incorporated	Less Than Significant Impact	No Impact
Would the project:				
a) Violate any water quality standards or waste discharge requirements or otherwise substantially degrade surface or ground water quality?	<input checked="" type="checkbox"/>	<input type="checkbox"/>	<input type="checkbox"/>	<input type="checkbox"/>
b) Substantially decrease groundwater supplies or interfere substantially with groundwater recharge such that the project may impede sustainable groundwater management of the basin?	<input type="checkbox"/>	<input type="checkbox"/>	<input checked="" type="checkbox"/>	<input type="checkbox"/>
c) Substantially alter the existing drainage pattern of the site or area, including through the alteration of the course of a stream or river or through the addition of impervious surfaces, in a manner which would:				
i. result in substantial erosion or siltation on- or off-site;	<input type="checkbox"/>	<input type="checkbox"/>	<input checked="" type="checkbox"/>	<input type="checkbox"/>
ii. substantially increase the rate or amount of surface runoff in a manner which would result in flooding on- or offsite;	<input type="checkbox"/>	<input type="checkbox"/>	<input checked="" type="checkbox"/>	<input type="checkbox"/>
iii. create or contribute runoff water which would exceed the capacity of existing or planned stormwater drainage systems or provide substantial additional sources of polluted runoff; or	<input type="checkbox"/>	<input type="checkbox"/>	<input checked="" type="checkbox"/>	<input type="checkbox"/>
iv. impede or redirect flood flows?	<input type="checkbox"/>	<input type="checkbox"/>	<input type="checkbox"/>	<input checked="" type="checkbox"/>
d) In flood hazard, tsunami, or seiche zones, risk release of pollutants due to project inundation?	<input type="checkbox"/>	<input type="checkbox"/>	<input type="checkbox"/>	<input checked="" type="checkbox"/>
e) Conflict with or obstruct implementation of a water quality control plan or sustainable groundwater management plan?	<input type="checkbox"/>	<input type="checkbox"/>	<input type="checkbox"/>	<input checked="" type="checkbox"/>

Impact Analysis

- a) **Potentially Significant Impact.** The proposed project has the potential to create urban non-point source discharge (e.g., synthetic/organic chemicals). Potentially significant water quality impacts have been identified and will be addressed in the EIR.
- b) **Less than Significant Impact.** During construction, potable water would be brought to the site for drinking and domestic needs, while construction water would be brought to the project site for soil conditioning and

dust suppression. During operations, potable water would be trucked onto the project site. Because the solar panels will be pole-mounted above ground, they are not considered “hardscape”, such as roads, building foundations, or parking areas, as they do not require a substantial amount of impervious material. The panels and their mounting foundation would not impede groundwater recharge. Therefore, impacts would be less than significant.

- ci) **Less than Significant Impact.** The proposed project would not substantially alter the existing drainage pattern of the site. It is anticipated that the proposed drainage patterns would be similar to the existing site conditions. The project applicant would be required to implement on-site erosion control measures in accordance with Imperial County standards including preparation, review, and approval of a grading plan by the Imperial County Engineer. The proposed project is not anticipated to generate a significant increase in the amount of runoff water from water use involving solar panel washing. Water will continue to percolate through the ground, as a majority of the surface on the project site will remain pervious. Therefore, the proposed project would not substantially increase the rate of runoff, in a manner which would exceed the capacity of existing or planned stormwater drainage systems and result in flooding on- or off-site. A less than significant impact is identified for this issue area.
- cii) **Less than Significant Impact.** Refer to response X. ci) above.
- ciii) **Less than Significant Impact.** Refer to response X. ci) above.
- civ) **No Impact.** According to the Federal Emergency Management Agency (FEMA) Flood Insurance Rate Map (Panel 06025C2125C) (FEMA 2008), the project site is within Zone X, which is an area determined to be outside of the 0.2 percent annual chance of a flood. The proposed project does not propose the placement of structures within a 100-year flood hazard area. Therefore, the proposed project would not impede or redirect flood flows. No impact is identified for this issue area and no further analysis is warranted.
- d) **No Impact.** The project site is within Zone X, which is an area determined to be outside of the 0.2 percent annual chance of a flood. The project site is not located near any large bodies of water. The Salton Sea is located approximately 37 miles northwest of the project site. Furthermore, the relatively flat project site is over 100 miles inland from the Pacific Ocean. Therefore, the proposed project would not risk release of pollutants due to project inundation by flood, tsunami or seiche. No impact is identified for this issue area.
- e) **No Impact.** The proposed project will not involve the use of groundwater nor require dewatering activities. Water to be used during project-related construction activities will be brought to the site and limited to the amount necessary for soil conditioning and to conduct dust control activities. Water is anticipated to be provided by adjacent IID irrigation canals or laterals in conformance with IID construction water acquisition requirements. Therefore, the proposed project will not conflict with or obstruct implementation of a water quality control plan or sustainable groundwater management plan. No impact is identified for this issue area.

XI. Land Use and Planning

Environmental Issue Area:	Potentially Significant Impact	Potentially Significant Unless Mitigation Incorporated	Less Than Significant Impact	No Impact
Would the project:				
a) Physically divide an established community?	<input type="checkbox"/>	<input type="checkbox"/>	<input type="checkbox"/>	<input checked="" type="checkbox"/>
b) Cause a significant environmental impact due to a conflict with any land use plan, policy, or regulation adopted for the purpose of avoiding or mitigating an environmental effect?	<input type="checkbox"/>	<input type="checkbox"/>	<input checked="" type="checkbox"/>	<input type="checkbox"/>

Impact Analysis

- a) **No Impact.** The proposed project is located in a sparsely populated, agriculturally zoned portion of Imperial County. There are no established residential communities located within or in the vicinity of the project site. Therefore, implementation of the proposed project would not divide an established community. No impact is identified for this issue area.
- b) **Less than Significant Impact.** The project site is currently designated by the General Plan as “Agriculture” and is zoned A-3-RE (Heavy Agriculture with a Renewable Energy Zone Overlay). Pursuant to Title 9, Division 5, Chapter 9, “Solar Energy Plants” and “Transmission lines, including supporting towers, poles microwave towers, utility substations” are uses that are permitted in the A-3 Zone, subject to approval of a CUP.

The County Land Use Ordinance, Division 17, includes the Renewable Energy Overlay Zone, which authorizes the development and operation of renewable energy projects, with an approved CUP. As shown on Figure 1, the project site is located entirely within the County’s Renewable Energy Overlay Zone. With approval of a CUP, the proposed solar facility would be consistent with the Imperial County Land Use Ordinance. Based on these considerations, the proposed project would not conflict with any applicable land use plan, policy, or regulation. Thus, a less than significant impact is identified for this issue area.

XII. Mineral Resources

Environmental Issue Area:	Potentially Significant Impact	Potentially Significant Unless Mitigation Incorporated	Less Than Significant Impact	No Impact
Would the project:				
a) Result in the loss of availability of a known mineral resource that would be of value to the region and the residents of the state?	<input type="checkbox"/>	<input type="checkbox"/>	<input type="checkbox"/>	<input checked="" type="checkbox"/>
b) Result in the loss of availability of a locally-important mineral resource recovery site delineated on a local general plan, specific plan, or other land use plan?	<input type="checkbox"/>	<input type="checkbox"/>	<input type="checkbox"/>	<input checked="" type="checkbox"/>

Impact Analysis

- a) **No Impact.** The project site is not used for mineral resource production. According to Figure 8: Imperial County Existing Mineral Resources of the Conservation and Open Space Element of the General Plan (County of Imperial 2016), no known mineral resources occur within the project site nor does the project site contain mapped mineral resources. Therefore, the proposed project would not result in the loss of availability of any known mineral resources that would be of value to the region and the residents of California nor would the proposed project result in the loss of availability of a locally important mineral resource. Thus, no impact is identified for this issue area and no further analysis is warranted.
- b) **No Impact.** Refer to response XIII. a) above.

XIII. Noise

Environmental Issue Area:	Potentially Significant Impact	Potentially Significant Unless Mitigation Incorporated	Less Than Significant Impact	No Impact
<i>Would the project result in:</i>				
a) Generation of a substantial temporary or permanent increase in ambient noise levels in the vicinity of the project in excess of standards established in the local general plan or noise ordinance, or applicable standards of other agencies?	<input type="checkbox"/>	<input type="checkbox"/>	<input checked="" type="checkbox"/>	<input type="checkbox"/>
b) Generation of excessive groundborne vibration or groundborne noise levels?	<input type="checkbox"/>	<input type="checkbox"/>	<input checked="" type="checkbox"/>	<input type="checkbox"/>
c) For a project located within the vicinity of a private airstrip or an airport land use plan or, where such a plan has not been adopted, within two miles of a public airport or public use airport, would the project expose people residing or working in the project area to excessive noise levels?	<input type="checkbox"/>	<input type="checkbox"/>	<input type="checkbox"/>	<input checked="" type="checkbox"/>

Impact Analysis

- a) **Less than Significant Impact.** The Imperial County Title 9 Land Use Ordinance, Division 7, Chapter 2, Section 90702.00 - Sound level limits, establishes one-hour average sound level limits for the County’s land use zones. Agricultural/industrial operations are required to comply with the noise levels prescribed under the general industrial zones. Therefore, the proposed project will be required to maintain noise levels below 75 decibels (dB) (averaged over one hour) during any time of day.

The proposed project will also be expected to comply with the Noise Element of the General Plan which states that construction noise, from a single piece of equipment or a combination of equipment, shall not exceed 75 dB, when averaged over an eight hour period, and measured at the nearest sensitive receptor. Construction equipment operation is also limited to the hours of 7 a.m. to 7 p.m., Monday through Friday, and 9 a.m. to 5 p.m on Saturday. Nevertheless, the proposed project will result in the increase in ambient noise levels during construction. A noise report that will address the proposed project’s potential noise impacts will be prepared and this issue will be addressed in the EIR.

- b) **Less than Significant Impact.** Groundborne vibration and noise could originate from earth movement during the construction phase of the proposed project. However, significant vibration is typically associated with activities such as blasting or the use of pile drivers, neither of which would be required during project construction. The proposed project would be expected to comply with all applicable requirements for long-term operation, as well as with measures to reduce excessive groundborne vibration and noise to ensure that the proposed project would not expose persons or structures to excessive groundborne vibration. Therefore, a less than significant impact has been identified for this issue area.

- c) **No Impact.** The project site is not located within 2 miles of a public airport or private airstrip. The nearest airport to the project site is the Calexico International Airport, located approximately 10 miles west of the project site. Therefore, the proposed project would not expose people residing or working in the project area to excess noise levels and no impact is identified for this issue area.

XIV. Population and Housing

Environmental Issue Area:	Potentially Significant Impact	Potentially Significant Unless Mitigation Incorporated	Less Than Significant Impact	No Impact
Would the project:				
a) Induce substantial unplanned population growth in an area, either directly (e.g., by proposing new homes and businesses) or indirectly (e.g., through extension of roads or other infrastructure)?	<input type="checkbox"/>	<input type="checkbox"/>	<input type="checkbox"/>	<input checked="" type="checkbox"/>
b) Displace substantial numbers of existing people or housing, necessitating the construction of replacement housing elsewhere?	<input type="checkbox"/>	<input type="checkbox"/>	<input type="checkbox"/>	<input checked="" type="checkbox"/>

Impact Analysis

- a) **No Impact.** Development of housing is not proposed as part of the proposed project. No full-time employees are required to operate the proposed project since the project facility will be monitored remotely. However, it is anticipated that maintenance of the facility will require minimal site presence to perform periodic visual inspections and minor repairs. On intermittent occasions, the presence of additional workers may be required for repairs or replacement of equipment and panel cleaning; however, due to the nature of the facility, such actions will likely occur infrequently. Therefore, the proposed project would not result in a substantial growth in the area, as the number of employees required to operate and maintain the facility is minimal. No impact is identified for this issue area.
- b) **No Impact.** No housing exists within the project site. Therefore, the proposed project would not displace any existing people or housing, which would require the construction of replacement housing elsewhere. No impact is identified for this issue area.

XV. Public Services

Environmental Issue Area:	Potentially Significant Impact	Potentially Significant Unless Mitigation Incorporated	Less Than Significant Impact	No Impact
a) Would the project result in substantial adverse physical impacts associated with the provision of new or physically altered governmental facilities, need for new or physically altered governmental facilities, the construction of which could cause significant environmental impacts, in order to maintain acceptable service ratios, response times or other performance objectives for any of the public services:				
i. Fire Protection?	<input type="checkbox"/>	<input type="checkbox"/>	<input checked="" type="checkbox"/>	<input type="checkbox"/>
ii. Police Protection?	<input checked="" type="checkbox"/>	<input type="checkbox"/>	<input type="checkbox"/>	<input type="checkbox"/>
iii. Schools?	<input type="checkbox"/>	<input type="checkbox"/>	<input type="checkbox"/>	<input type="checkbox"/>
iv. Parks?	<input type="checkbox"/>	<input type="checkbox"/>	<input type="checkbox"/>	<input checked="" type="checkbox"/>
v. Other public facilities?	<input type="checkbox"/>	<input type="checkbox"/>	<input type="checkbox"/>	<input checked="" type="checkbox"/>

Impact Analysis

- ai) **Less than Significant Impact.** Fire protection and emergency medical services in the project area are provided by the Imperial County Fire Department. The proposed site is located in the unincorporated area of Imperial County. According to the Seismic and Public Safety Element of the General Plan (County of Imperial 1997), the potential for a major fire in the unincorporated areas of the County is generally low. A 10,000-gallon aboveground water storage tank(s) would be installed on the project site as required by the Imperial County Fire Department. The water tank(s) would be sized to meet the requirements of the County of Imperial to supply sufficient fire suppression water during operations. Both the access and service roads (along the perimeter of the project facility) would have turnaround areas to allow clearance for fire trucks per fire department standards (70 feet by 70 feet, and minimum 20-foot-wide access road). The project applicant will be required to consult with the Fire Department to address any fire safety and service concerns so that adequate service is maintained. Based on these considerations, the project would not result in a need for fire facility expansion and a less than significant impact is identified for this issue area.
- aii) **Potentially Significant Impact.** Police protection services in the project area is provided by the Imperial County Sheriff's Department. Although the potential is low, the proposed project may attract vandals or other security risks and the increase in construction related traffic could increase demand on law enforcement services. Therefore, on-site security systems would be provided and access would be limited to the areas surrounding the project site during construction and operation, thereby minimizing the need for police surveillance. The proposed project's potentially significant impacts on sheriff services will be addressed in the EIR.
- aiii) **No Impact.** The proposed project does not include the development of residential land uses that would result in an increase in population or student generation. Additionally, construction of the proposed project would not result in an increase in student population within the Imperial County's School District since it is anticipated that construction workers would commute in during construction operations. Therefore, no impact is identified for this issue area and no further analysis is warranted.
- aiv) **No Impact.** Although maintenance of the project facility will require minimal site presence to perform periodic visual inspections and minor repairs, no full-time employees are required to operate the proposed project because the project facility will be monitored remotely. Therefore, substantial permanent increases in population that would adversely affect local parks is not expected. No impact is identified for this issue area and no further analysis is warranted.

- av) **No Impact.** Although maintenance of the project facility will require minimal site presence to perform periodic visual inspections and minor repairs, no full-time employees are required to operate the proposed project because the project facility will be monitored remotely. Therefore, substantial permanent increases in population that would adversely affect libraries and other public facilities (such as post offices) is not expected. The proposed project is not expected to have an impact on other public facilities such as post offices, and libraries. No impact is identified for this issue area and no further analysis is warranted.

XVI. Recreation

Environmental Issue Area:	Potentially Significant Impact	Potentially Significant Unless Mitigation Incorporated	Less Than Significant Impact	No Impact
Would the project:				
a) Would the project increase the use of existing neighborhood and regional parks or other recreational facilities such that substantial physical deterioration of the facility would occur or be accelerated?	<input type="checkbox"/>	<input type="checkbox"/>	<input type="checkbox"/>	<input checked="" type="checkbox"/>
b) Does the project include recreational facilities or require the construction or expansion of recreational facilities, which might have an adverse physical effect on the environment?	<input type="checkbox"/>	<input type="checkbox"/>	<input type="checkbox"/>	<input checked="" type="checkbox"/>

Impact Analysis

- a) **No Impact.** The proposed project would not generate new employment on a long-term basis. As such, the proposed project would not significantly increase the use or accelerate the deterioration of regional parks or other recreational facilities. The temporary increase of population during construction that might be caused by an influx of workers would be minimal and not cause a detectable increase in the use of parks. Additionally, the proposed project would not include or require the expansion of recreational facilities. No impact is identified for this issue area and no further analysis is warranted.
- b) **No Impact.** Refer to response XVI. a) above.

XVII. Transportation

Environmental Issue Area:	Potentially Significant Impact	Potentially Significant Unless Mitigation Incorporated	Less Than Significant Impact	No Impact
Would the project:				
a) Conflict with a program plan, ordinance or policy addressing the circulation system, including transit, roadway, bicycle and pedestrian facilities?	<input checked="" type="checkbox"/>	<input type="checkbox"/>	<input type="checkbox"/>	<input type="checkbox"/>
b) Conflict with or be inconsistent with CEQA Guidelines section 15064.3, subdivision (b)?	<input checked="" type="checkbox"/>	<input type="checkbox"/>	<input type="checkbox"/>	<input type="checkbox"/>
c) Substantially increase hazards due to a geometric design feature (e.g., sharp curves or dangerous intersections) or incompatible uses (e.g., farm equipment)?	<input type="checkbox"/>	<input type="checkbox"/>	<input type="checkbox"/>	<input checked="" type="checkbox"/>
d) Result in inadequate emergency access?	<input type="checkbox"/>	<input type="checkbox"/>	<input checked="" type="checkbox"/>	<input type="checkbox"/>

Impact Analysis

- a) **Potentially Significant Impact.** Construction of the proposed project would result in a small increase of traffic to the area, which may result in a potentially significant impact. Therefore, a traffic impact study that will address the proposed project's potential impacts on transportation will be prepared, and this issue will be addressed in the EIR.
- b) **Potentially Significant Impact.** Section 15064.3(b) of the CEQA Guidelines provides guidance on determining the significance of transportation impacts and focuses on the use of vehicle miles traveled (VMT), which is defined as the amount and distance of automobile travel associated with a project. Given the nature of the project, after construction, there would be a nominal amount of vehicle trips generated by the project. Once the proposed project is implemented, the proposed project would require intermittent maintenance requiring a negligible amount of traffic trips on an annual basis. However minimal, the proposed project would increase the number of vehicular trips related to construction and the need for intermittent maintenance on an annual basis. Therefore, this issue is potentially significant and will be addressed in the traffic impact study and EIR analysis.
- c) **No Impact.** To accommodate emergency access, PV panels would be spaced to maintain proper clearance. Internal access roads, up to 30-feet wide, would be constructed along the perimeter fence and solar panels to facilitate vehicle access and maneuverability for emergency unit vehicles. Access roads would be graded and compacted (native soils) as required for construction, operations, maintenance, and emergency vehicle access. These access roads would not increase hazards because of design features or incompatible uses. Therefore, no impact will occur.
- d) **Less than Significant Impact.** To accommodate emergency access, PV panels would be spaced to maintain proper clearance. 30-foot wide internal access roads would be constructed along the perimeter fence and solar panels to facilitate vehicle access and maneuverability for emergency unit vehicles. The internal access roads would be graded and compacted (native soils) as required for construction, operations, maintenance, and emergency vehicle access. The access and service roads would also have turnaround areas at any dead-end to allow clearance for fire trucks per fire department standards. Based on this context, impacts are considered less than significant.

XVIII. Tribal Cultural Resources

Environmental Issue Area:	Potentially Significant Impact	Potentially Significant Unless Mitigation Incorporated	Less Than Significant Impact	No Impact
<i>Would the project cause a substantial adverse change in the significance of a tribal cultural resource defined in Public Resources Code section 21074 as either a site, feature, place, cultural landscape that is geographically defined in terms of the size and scope of the landscape, sacred place, or object with cultural value to a California Native American tribe, and that is:</i>				
a) Listed or eligible for listing in the California Register of Historical Resources, or in a local register of historical resources as defined in Public Resources Code section 5020.1(k)?	<input checked="" type="checkbox"/>	<input type="checkbox"/>	<input type="checkbox"/>	<input type="checkbox"/>
b) A resource determined by the lead agency, in its discretion and supported by substantial evidence, to be significant pursuant to criteria set forth in subdivision (c) of Public Resources Code Section 5024.1. In applying the criteria set forth in subdivision (c) of Public Resources Code Section 5024.1, the lead agency shall consider the significance of the resource to a California Native American tribe?	<input checked="" type="checkbox"/>	<input type="checkbox"/>	<input type="checkbox"/>	<input type="checkbox"/>

Impact Analysis

a-b) **Potentially Significant Impact.** Assembly Bill 52 was passed in 2014 and took effect July 1, 2015. It established a new category of environmental resources that must be considered under CEQA called tribal cultural resources (Public Resources Code 21074) and established a process for consulting with Native American tribes and groups regarding those resources. Assembly Bill 52 requires a lead agency to begin consultation with a California Native American tribe that is traditionally and culturally affiliated with the geographic area of the proposed project.

In accordance with AB 52, Imperial County, as the CEQA lead agency, sent an AB 52 consultation request letter to the Quechan Indian Tribe on March 26, 2021. On April 1, 2021, the Quechan Indian Tribe requested consultation with the County on the project. The County is in the process of consulting with the Quechan Indian Tribe on the project. This issue will be further analyzed in the EIR.

XIX. Utilities and Service Systems

Environmental Issue Area:	Potentially Significant Impact	Potentially Significant Unless Mitigation Incorporated	Less Than Significant Impact	No Impact
Would the project:				
a) Require or result in the relocation or construction of new or expanded water, wastewater treatment or storm water drainage, electric power, natural gas, or telecommunications facilities, the construction or relocation of which could cause significant environmental effects?	<input checked="" type="checkbox"/>	<input type="checkbox"/>	<input type="checkbox"/>	<input type="checkbox"/>
b) Have sufficient water supplies available to serve the project and reasonably foreseeable future development during normal, dry and multiple dry years?	<input checked="" type="checkbox"/>	<input type="checkbox"/>	<input type="checkbox"/>	<input type="checkbox"/>
c) Result in a determination by the wastewater treatment provider, which serves or may serve the project that it has adequate capacity to serve the project's projected demand in addition to the provider's existing commitments?	<input type="checkbox"/>	<input type="checkbox"/>	<input checked="" type="checkbox"/>	<input type="checkbox"/>
d) Generate solid waste in excess of State or local standards, or in excess of the capacity of local infrastructure, or otherwise impair the attainment of solid waste reduction goals?	<input type="checkbox"/>	<input type="checkbox"/>	<input checked="" type="checkbox"/>	<input type="checkbox"/>
e) Comply with federal, state, and local management and reduction statutes and regulations related to solid waste?	<input type="checkbox"/>	<input type="checkbox"/>	<input checked="" type="checkbox"/>	<input type="checkbox"/>

Impact Analysis

- a) **Potentially Significant Impact.** No IID drains or canals will be impacted by the proposed project. The proposed project does not require expanded or new storm drainage facilities because the proposed solar facility would not generate a significant increase in the amount of impervious surfaces that would increase runoff during storm events and exceed the capacity of existing or planned stormwater drainage systems. Water from solar panel washing would continue to percolate through the ground, as a majority of the surfaces within the project site would remain pervious.

The wastewater generated during construction would be contained within portable toilet facilities and disposed of at an approved site. The minimal volume of wastewater generated during construction would not require the relocation expansion, or construction of wastewater treatment facilities. Further, no habitable structures (e.g. housing or O&M buildings) are proposed on the project site. Therefore, the proposed project would not require or result in the relocation or construction of new or expanded electric power, natural gas, or telecommunications facilities.

Although water for solar panel washing and fire protection (on-site storage) during project operation is not anticipated to result in a significant increase in water demand/use, IID would provide the water required for operations and maintenance and potable water will be trucked onto the site. Thus, a potentially significant impact is identified for the availability of sufficient water supplies to serve the proposed project for the reasonably foreseeable future. A water supply assessment that will address the proposed project's potential impacts on water supplies will be prepared and included in the EIR analysis.

- b) **Potentially Significant Impact.** Refer to response XIX. a) above.
- c) **Less than Significant Impact.** The proposed project would generate a minimal volume of wastewater during construction. During construction activities, wastewater would be contained within portable toilet facilities and disposed of at an approved site. Further, no habitable structures (e.g. housing or O&M buildings) are proposed on the project site; therefore, there would be no wastewater generation from the proposed project during operation. The proposed project would not exceed wastewater treatment requirements of the RWQCB. Therefore, a less than significant impact is identified for this issue area.
- d) **Less than Significant Impact.** Solid waste generation would be minor for the construction and operation of the proposed project. Solid waste will be disposed of using a locally-licensed waste hauling service, most likely Allied Waste. Trash would likely be hauled to the Calexico Solid Waste Site (13-AA-0004) located approximately 13 miles west of the proposed project in Calexico. The Calexico Solid Waste Site has approximately 1,561,235 cubic yards of remaining capacity and is estimated to remain in operation through 2179 (CalRecycle n.d.). Therefore, there is ample landfill capacity in the County to receive the minor amount of solid waste generated by construction and operation of the proposed project.

Additionally, because the proposed project would generate solid waste during construction and operation, they will be required to comply with state and local requirements for waste reduction and recycling; including the 1989 California Integrated Waste Management Act and the 1991 California Solid Waste Reuse and Recycling Access Act of 1991. Also, conditions of the conditional use permit will contain provisions for recycling and diversion of Imperial County construction waste policies. Therefore, a less than significant impact is identified for this issue area.

- e) **Less than Significant Impact.** Refer to response XIX. d) above.

XX. Wildfire

Environmental Issue Area:	Potentially Significant Impact	Potentially Significant Unless Mitigation Incorporated	Less Than Significant Impact	No Impact
<i>If located in or near state responsibility areas or lands classified as very high fire hazard severity zones, would the project:</i>				
a) Substantially impair an adopted emergency response plan or emergency evacuation plan?	<input type="checkbox"/>	<input type="checkbox"/>	<input type="checkbox"/>	<input checked="" type="checkbox"/>
b) Due to slope, prevailing winds, and other factors, exacerbate wildfire risks, and thereby expose project occupants to, pollutant concentrations from a wildfire or the uncontrolled spread of a wildfire?	<input type="checkbox"/>	<input type="checkbox"/>	<input type="checkbox"/>	<input checked="" type="checkbox"/>
c) Require the installation or maintenance of associated infrastructure (such as roads, fuel breaks, emergency water sources, power lines or other utilities) that may exacerbate fire risk or that may result in temporary or ongoing impacts to the environment?	<input type="checkbox"/>	<input type="checkbox"/>	<input checked="" type="checkbox"/>	<input type="checkbox"/>
d) Expose people or structures to significant risks, including downslope or downstream flooding or landslides, as a result of runoff, post-fire slope instability, or drainage changes?	<input type="checkbox"/>	<input type="checkbox"/>	<input type="checkbox"/>	<input checked="" type="checkbox"/>

Impact Analysis

- a) **No Impact.** According to the Fire Hazard Severity Zone Viewer provided by the California Department of Forestry and Fire Protection, the proposed project is not located in or near state responsibility areas or lands classified as very high hazard severity zones (California Department of Forestry and Fire Protection 2020). Therefore, the proposed project would not substantially impair an adopted emergency response plan or emergency evacuation plan. No impact is identified for this issue area.
- b) **No Impact.** The proposed project is not located in or near state responsibility areas or lands classified as very high hazard severity zones (California Department of Forestry and Fire Protection 2020). Therefore, the proposed project would not exacerbate wildfire risks. No impact is identified for this issue area.
- c) **Less than Significant Impact.** Fire protection and emergency medical services in the area are provided by the Imperial County Fire Department. The proposed project is not located in or near state responsibility areas or lands classified as very high hazard severity zones (California Department of Forestry and Fire Protection 2020). Further, the proposed project is located in an unincorporated area of Imperial County, which has a generally low potential for a major fire (County of Imperial 2016).

The project involves the installation of solar PV panels on fixed frames or single-axis horizontal trackers, an on-site substation and inverters, transformers, underground electrical cables, and 10,000-gallon aboveground water storage tank as required by the Imperial County Fire Department. The water tank(s) would be sized to meet the requirements of the County of Imperial to supply sufficient fire suppression water during operations. Further, the project site would be accessible from a primary and secondary (if required) access driveway that would have turnaround areas to allow clearance for fire trucks per fire department standards (30-foot-wide access road) and 30-foot double swing gates with keyed entry. In addition, operation and maintenance would not affect the ability of fire personnel to respond to fires. Therefore, the

proposed project would not exacerbate fire risk and would continue to be adequately supported by the existing fire protection services. A less than significant impact is identified for this issue area.

- d) **No Impact.** The proposed project is not located in or near state responsibility areas or lands classified as very high hazard severity zones (California Department of Forestry and Fire Protection 2020). Additionally, the proposed project would not expose people or structures to significant risks, including downslope or downstream flooding or landslides, as a result of runoff, post-fire slope instability, or drainage changes. No impact is identified for this issue area and no further analysis is warranted.

XXI. Mandatory Findings of Significance

Environmental Issue Area:	Potentially Significant Impact	Potentially Significant Unless Mitigation Incorporated	Less Than Significant Impact	No Impact
Would the project:				
a) Does the project have the potential to substantially degrade the quality of the environment, substantially reduce the habitat of a fish or wildlife species, cause a fish or wildlife population to drop below self-sustaining levels, threaten to eliminate a plant or animal community, substantially reduce the number or restrict the range of a rare or endangered plant or animal or eliminate important examples of the major periods of California history or prehistory?	<input checked="" type="checkbox"/>	<input type="checkbox"/>	<input type="checkbox"/>	<input type="checkbox"/>
b) Does the project have impacts that are individually limited, but cumulatively considerable ("Cumulatively considerable" means that the incremental effects of a project are considerable when viewed in connection with the effects of past projects, the effects of other current projects, and the effects of probable future projects)?	<input checked="" type="checkbox"/>	<input type="checkbox"/>	<input type="checkbox"/>	<input type="checkbox"/>
c) Does the project have environmental effects, which will cause substantial adverse effects on human beings, either directly or indirectly?	<input checked="" type="checkbox"/>	<input type="checkbox"/>	<input type="checkbox"/>	<input type="checkbox"/>

Impact Analysis

- a) **Potentially Significant Impact.** The proposed project has the potential to result in significant environmental effects on biological resources and cultural resources, which could directly or indirectly cause adverse effects on the environment. These issues will be further evaluated in the EIR.
- b) **Potentially Significant Impact.** Implementation of the proposed project has the potential to result in impacts related to: aesthetics, agricultural resources, air quality, biological resources, cultural resources, geology/soils, greenhouse gas emissions, hydrology and water quality, public services, transportation, tribal cultural resources, and utilities/service systems.. The proposed project has the potential to result in cumulative impacts with regards to the identified issue areas. Cumulative impacts will be discussed and further analyzed in the EIR.
- c) **Potentially Significant Impact.** Implementation of the proposed project has the potential to result in impacts related to: air quality and geology/soils. These potential environmental effects could cause substantial adverse effects on human beings. These issues will be further evaluated in the EIR.

References

- California Department of Conservation (DOC). 2016a. *Imperial County Important Farmland 2016*. Accessed March 2021.
- 2016b. *Imperial County Williamson Act FY 2016/2017*. Accessed March 2021.
- California Department of Forestry and Fire Protection. 2020. Fire Hazard Severity Zone Viewer. <https://gis.data.ca.gov/datasets/789d5286736248f69c4515c04f58f414>. Accessed March 2021.
- California Department of Resources Recycling and Recovery (CalRecycle). n.d. Facility/Site Summary Details: Niland Solid Waste Site (13-AA-0009). <https://www2.calrecycle.ca.gov/SolidWaste/SiteActivity/Details/4179?siteID=591>. Accessed March 2021.
- California Department of Transportation (Caltrans). 2018. California Scenic Highway Mapping System. <https://dot.ca.gov/programs/design/lap-landscape-architecture-and-community-livability/lap-liv-i-scenic-highways>. Accessed March 2021.
- County of Imperial. 1997. County of Imperial General Plan. Seismic and Public Safety Element. <https://www.icpds.com/assets/planning/seismic-and-public-safety.pdf>. Accessed March 2021.
- 2016. County of Imperial General Plan. Conservation and Open Space Element. <https://www.icpds.com/planning/land-use-documents/general-plan/conservation-and-open-space-element>. Accessed March 2021.
- 2019a. Imperial County Land Use Ordinance: Title 9, Division 4. https://library.municode.com/ca/imperial_county/codes/code_of_ordinances?nodeId=TIT9LAUSCO_DIV17GEPR. Accessed March 2021.
- 2019b. Imperial County Land Use Ordinance: Title 9, Division 17. https://library.municode.com/ca/imperial_county/codes/code_of_ordinances?nodeId=TIT9LAUSCO_DIV17GEPR. Accessed March 2021.
- Department of Toxic Substances Control. 2021. EnviroStor – Hazardous Waste and Substances Site List (Cortese). https://www.envirostor.dtsc.ca.gov/public/search?cmd=search&reporttype=CORTESE&site_type=CSITES,FUDS&status=ACT,BKLG,COM&reporttitle=HAZARDOUS+WASTE+AND+SUBSTANCES+SITE+LIST+%28CORTESE%29. Accessed March 2021.
- Federal Emergency Management Agency (FEMA). 2008. Flood Insurance Rate Map (Panel 06025C2125C). <https://msc.fema.gov/portal/search?AddressQuery=2307%20CA-98%2C%20Holtville%2C%20CA%2092250#searchresultsanchor>. Accessed March 2021.
- Historic Aerials. 2021. Historic Aerials. <https://www.historicaerials.com/viewer>. Accessed March 2021.

List of Preparers

This Initial Study was prepared for the Imperial County Planning and Development Services Department by HDR at 591 Camino de la Reina, Suite 300, San Diego, CA 92108. The following professionals participated in its preparation:

Imperial County Planning and Development Services Department

Jim Minnick, Planning and Development Services Director

Michael Abraham, AICP, Assistant Planning and Development Services Director

Diana Robinson, Planner III

HDR

Tim Gnibus, Principal

Sharyn Del Rosario, Project Manager

Elaine Lee, Environmental Planner

Anders Burvall, Senior Geographic Information Systems Analyst

Renee Stueber, Document Production Administrator

Comment Letters Received on Notice of Preparation



NATIVE AMERICAN HERITAGE COMMISSION

May 5, 2021

Diana Robinson
Imperial County
801 Main Street
El Centro, CA 92243

CHAIRPERSON
Laura Miranda
Luiseño

VICE CHAIRPERSON
Reginald Pagaling
Chumash

SECRETARY
Merrí Lopez-Keifer
Luiseño

PARLIAMENTARIAN
Russell Atebery
Karuk

COMMISSIONER
William Mungary
Paiute/White Mountain
Apache

COMMISSIONER
Julie Tumamait-Stenslie
Chumash

COMMISSIONER
[Vacant]

COMMISSIONER
[Vacant]

COMMISSIONER
[Vacant]

EXECUTIVE SECRETARY
Christina Snider
Pomo

NAHC HEADQUARTERS
1550 Harbor Boulevard
Suite 100
West Sacramento,
California 95691
(916) 373-3710
nahc@nahc.ca.gov
NAHC.ca.gov

Re: 2021050018, VEGA SES 4 Solar Energy Project, Imperial County

Dear Ms. Robinson:

The Native American Heritage Commission (NAHC) has received the Notice of Preparation (NOP), Draft Environmental Impact Report (DEIR) or Early Consultation for the project referenced above. The California Environmental Quality Act (CEQA) (Pub. Resources Code §21000 et seq.), specifically Public Resources Code §21084.1, states that a project that may cause a substantial adverse change in the significance of a historical resource, is a project that may have a significant effect on the environment. (Pub. Resources Code § 21084.1; Cal. Code Regs., tit.14, §15064.5 (b) (CEQA Guidelines § 15064.5 (b)). If there is substantial evidence, in light of the whole record before a lead agency, that a project may have a significant effect on the environment, an Environmental Impact Report (EIR) shall be prepared. (Pub. Resources Code §21080 (d); Cal. Code Regs., tit. 14, § 5064 subd.(a)(1) (CEQA Guidelines § 15064 (a)(1)). In order to determine whether a project will cause a substantial adverse change in the significance of a historical resource, a lead agency will need to determine whether there are historical resources within the area of potential effect (APE).

CEQA was amended significantly in 2014. Assembly Bill 52 (Gatto, Chapter 532, Statutes of 2014) (AB 52) amended CEQA to create a separate category of cultural resources, "tribal cultural resources" (Pub. Resources Code §21074) and provides that a project with an effect that may cause a substantial adverse change in the significance of a tribal cultural resource is a project that may have a significant effect on the environment. (Pub. Resources Code §21084.2). Public agencies shall, when feasible, avoid damaging effects to any tribal cultural resource. (Pub. Resources Code §21084.3 (a)). **AB 52 applies to any project for which a notice of preparation, a notice of negative declaration, or a mitigated negative declaration is filed on or after July 1, 2015.** If your project involves the adoption of or amendment to a general plan or a specific plan, or the designation or proposed designation of open space, on or after March 1, 2005, it may also be subject to Senate Bill 18 (Burton, Chapter 905, Statutes of 2004) (SB 18). **Both SB 18 and AB 52 have tribal consultation requirements.** If your project is also subject to the federal National Environmental Policy Act (42 U.S.C. § 4321 et seq.) (NEPA), the tribal consultation requirements of Section 106 of the National Historic Preservation Act of 1966 (154 U.S.C. 300101, 36 C.F.R. §800 et seq.) may also apply.

The NAHC recommends consultation with California Native American tribes that are traditionally and culturally affiliated with the geographic area of your proposed project as early as possible in order to avoid inadvertent discoveries of Native American human remains and best protect tribal cultural resources. Below is a brief summary of portions of AB 52 and SB 18 as well as the NAHC's recommendations for conducting cultural resources assessments.

Consult your legal counsel about compliance with AB 52 and SB 18 as well as compliance with any other applicable laws.

RECEIVED

MAY 10 2021

**IMPERIAL COUNTY
PLANNING & DEVELOPMENT SERVICES**

AB 52 has added to CEQA the additional requirements listed below, along with many other requirements:

- 1. Fourteen Day Period to Provide Notice of Completion of an Application/Decision to Undertake a Project:** Within fourteen (14) days of determining that an application for a project is complete or of a decision by a public agency to undertake a project, a lead agency shall provide formal notification to a designated contact of, or tribal representative of, traditionally and culturally affiliated California Native American tribes that have requested notice, to be accomplished by at least one written notice that includes:

 - a. A brief description of the project.
 - b. The lead agency contact information.
 - c. Notification that the California Native American tribe has 30 days to request consultation. (Pub. Resources Code §21080.3.1 (d)).
 - d. A "California Native American tribe" is defined as a Native American tribe located in California that is on the contact list maintained by the NAHC for the purposes of Chapter 905 of Statutes of 2004 (SB 18). (Pub. Resources Code §21073).

- 2. Begin Consultation Within 30 Days of Receiving a Tribe's Request for Consultation and Before Releasing a Negative Declaration, Mitigated Negative Declaration, or Environmental Impact Report:** A lead agency shall begin the consultation process within 30 days of receiving a request for consultation from a California Native American tribe that is traditionally and culturally affiliated with the geographic area of the proposed project. (Pub. Resources Code §21080.3.1, subs. (d) and (e)) and prior to the release of a negative declaration, mitigated negative declaration or Environmental Impact Report. (Pub. Resources Code §21080.3.1(b)).

 - a. For purposes of AB 52, "consultation shall have the same meaning as provided in Gov. Code §65352.4 (SB 18). (Pub. Resources Code §21080.3.1 (b)).

- 3. Mandatory Topics of Consultation If Requested by a Tribe:** The following topics of consultation, if a tribe requests to discuss them, are mandatory topics of consultation:

 - a. Alternatives to the project.
 - b. Recommended mitigation measures.
 - c. Significant effects. (Pub. Resources Code §21080.3.2 (a)).

- 4. Discretionary Topics of Consultation:** The following topics are discretionary topics of consultation:

 - a. Type of environmental review necessary.
 - b. Significance of the tribal cultural resources.
 - c. Significance of the project's impacts on tribal cultural resources.
 - d. If necessary, project alternatives or appropriate measures for preservation or mitigation that the tribe may recommend to the lead agency. (Pub. Resources Code §21080.3.2 (a)).

- 5. Confidentiality of Information Submitted by a Tribe During the Environmental Review Process:** With some exceptions, any information, including but not limited to, the location, description, and use of tribal cultural resources submitted by a California Native American tribe during the environmental review process shall not be included in the environmental document or otherwise disclosed by the lead agency or any other public agency to the public, consistent with Government Code §6254 (r) and §6254.10. Any information submitted by a California Native American tribe during the consultation or environmental review process shall be published in a confidential appendix to the environmental document unless the tribe that provided the information consents, in writing, to the disclosure of some or all of the information to the public. (Pub. Resources Code §21082.3 (c)(1)).

- 6. Discussion of Impacts to Tribal Cultural Resources in the Environmental Document:** If a project may have a significant impact on a tribal cultural resource, the lead agency's environmental document shall discuss both of the following:

 - a. Whether the proposed project has a significant impact on an identified tribal cultural resource.
 - b. Whether feasible alternatives or mitigation measures, including those measures that may be agreed to pursuant to Public Resources Code §21082.3, subdivision (a), avoid or substantially lessen the impact on the identified tribal cultural resource. (Pub. Resources Code §21082.3 (b)).

- 7. Conclusion of Consultation:** Consultation with a tribe shall be considered concluded when either of the following occurs:
- a. The parties agree to measures to mitigate or avoid a significant effect, if a significant effect exists, on a tribal cultural resource; or
 - b. A party, acting in good faith and after reasonable effort, concludes that mutual agreement cannot be reached. (Pub. Resources Code §21080.3.2 (b)).
- 8. Recommending Mitigation Measures Agreed Upon in Consultation in the Environmental Document:** Any mitigation measures agreed upon in the consultation conducted pursuant to Public Resources Code §21080.3.2 shall be recommended for inclusion in the environmental document and in an adopted mitigation monitoring and reporting program, if determined to avoid or lessen the impact pursuant to Public Resources Code §21082.3, subdivision (b), paragraph 2, and shall be fully enforceable. (Pub. Resources Code §21082.3 (a)).
- 9. Required Consideration of Feasible Mitigation:** If mitigation measures recommended by the staff of the lead agency as a result of the consultation process are not included in the environmental document or if there are no agreed upon mitigation measures at the conclusion of consultation, or if consultation does not occur, and if substantial evidence demonstrates that a project will cause a significant effect to a tribal cultural resource, the lead agency shall consider feasible mitigation pursuant to Public Resources Code §21084.3 (b). (Pub. Resources Code §21082.3 (e)).
- 10. Examples of Mitigation Measures That, If Feasible, May Be Considered to Avoid or Minimize Significant Adverse Impacts to Tribal Cultural Resources:**
- a. Avoidance and preservation of the resources in place, including, but not limited to:
 - i. Planning and construction to avoid the resources and protect the cultural and natural context.
 - ii. Planning greenspace, parks, or other open space, to incorporate the resources with culturally appropriate protection and management criteria.
 - b. Treating the resource with culturally appropriate dignity, taking into account the tribal cultural values and meaning of the resource, including, but not limited to, the following:
 - i. Protecting the cultural character and integrity of the resource.
 - ii. Protecting the traditional use of the resource.
 - iii. Protecting the confidentiality of the resource.
 - c. Permanent conservation easements or other interests in real property, with culturally appropriate management criteria for the purposes of preserving or utilizing the resources or places.
 - d. Protecting the resource. (Pub. Resource Code §21084.3 (b)).
 - e. Please note that a federally recognized California Native American tribe or a non-federally recognized California Native American tribe that is on the contact list maintained by the NAHC to protect a California prehistoric, archaeological, cultural, spiritual, or ceremonial place may acquire and hold conservation easements if the conservation easement is voluntarily conveyed. (Civ. Code §815.3 (c)).
 - f. Please note that it is the policy of the state that Native American remains and associated grave artifacts shall be repatriated. (Pub. Resources Code §5097.991).
- 11. Prerequisites for Certifying an Environmental Impact Report or Adopting a Mitigated Negative Declaration or Negative Declaration with a Significant Impact on an Identified Tribal Cultural Resource:** An Environmental Impact Report may not be certified, nor may a mitigated negative declaration or a negative declaration be adopted unless one of the following occurs:
- a. The consultation process between the tribes and the lead agency has occurred as provided in Public Resources Code §21080.3.1 and §21080.3.2 and concluded pursuant to Public Resources Code §21080.3.2.
 - b. The tribe that requested consultation failed to provide comments to the lead agency or otherwise failed to engage in the consultation process.
 - c. The lead agency provided notice of the project to the tribe in compliance with Public Resources Code §21080.3.1 (d) and the tribe failed to request consultation within 30 days. (Pub. Resources Code §21082.3 (d)).

The NAHC's PowerPoint presentation titled, "Tribal Consultation Under AB 52: Requirements and Best Practices" may be found online at: http://nahc.ca.gov/wp-content/uploads/2015/10/AB52TribalConsultation_CalePAPDF.pdf

SB 18

SB 18 applies to local governments and requires local governments to contact, provide notice to, refer plans to, and consult with tribes prior to the adoption or amendment of a general plan or a specific plan, or the designation of open space. (Gov. Code §65352.3). Local governments should consult the Governor's Office of Planning and Research's "Tribal Consultation Guidelines," which can be found online at: https://www.opr.ca.gov/docs/09_14_05_Updated_Guidelines_922.pdf.

Some of SB 18's provisions include:

1. **Tribal Consultation**: If a local government considers a proposal to adopt or amend a general plan or a specific plan, or to designate open space it is required to contact the appropriate tribes identified by the NAHC by requesting a "Tribal Consultation List." If a tribe, once contacted, requests consultation the local government must consult with the tribe on the plan proposal. **A tribe has 90 days from the date of receipt of notification to request consultation unless a shorter timeframe has been agreed to by the tribe.** (Gov. Code §65352.3 (a)(2)).
2. **No Statutory Time Limit on SB 18 Tribal Consultation**. There is no statutory time limit on SB 18 tribal consultation.
3. **Confidentiality**: Consistent with the guidelines developed and adopted by the Office of Planning and Research pursuant to Gov. Code §65040.2, the city or county shall protect the confidentiality of the information concerning the specific identity, location, character, and use of places, features and objects described in Public Resources Code §5097.9 and §5097.993 that are within the city's or county's jurisdiction. (Gov. Code §65352.3 (b)).
4. **Conclusion of SB 18 Tribal Consultation**: Consultation should be concluded at the point in which:
 - a. The parties to the consultation come to a mutual agreement concerning the appropriate measures for preservation or mitigation; or
 - b. Either the local government or the tribe, acting in good faith and after reasonable effort, concludes that mutual agreement cannot be reached concerning the appropriate measures of preservation or mitigation. (Tribal Consultation Guideline, Governor's Office of Planning and Research (2005) at p. 18).

Agencies should be aware that neither AB 52 nor SB 18 precludes agencies from initiating tribal consultation with tribes that are traditionally and culturally affiliated with their jurisdictions before the timeframes provided in AB 52 and SB 18. For that reason, we urge you to continue to request Native American Tribal Contact Lists and "Sacred Lands File" searches from the NAHC. The request forms can be found online at: <http://nahc.ca.gov/resources/forms/>.

NAHC Recommendations for Cultural Resources Assessments

To adequately assess the existence and significance of tribal cultural resources and plan for avoidance, preservation in place, or barring both, mitigation of project-related impacts to tribal cultural resources, the NAHC recommends the following actions:

1. Contact the appropriate regional California Historical Research Information System (CHRIS) Center (http://ohp.parks.ca.gov/?page_id=1068) for an archaeological records search. The records search will determine:
 - a. If part or all of the APE has been previously surveyed for cultural resources.
 - b. If any known cultural resources have already been recorded on or adjacent to the APE.
 - c. If the probability is low, moderate, or high that cultural resources are located in the APE.
 - d. If a survey is required to determine whether previously unrecorded cultural resources are present.
2. If an archaeological inventory survey is required, the final stage is the preparation of a professional report detailing the findings and recommendations of the records search and field survey.
 - a. The final report containing site forms, site significance, and mitigation measures should be submitted immediately to the planning department. All information regarding site locations, Native American human remains, and associated funerary objects should be in a separate confidential addendum and not be made available for public disclosure.
 - b. The final written report should be submitted within 3 months after work has been completed to the appropriate regional CHRIS center.

3. Contact the NAHC for:
 - a. A Sacred Lands File search. Remember that tribes do not always record their sacred sites in the Sacred Lands File, nor are they required to do so. A Sacred Lands File search is not a substitute for consultation with tribes that are traditionally and culturally affiliated with the geographic area of the project's APE.
 - b. A Native American Tribal Consultation List of appropriate tribes for consultation concerning the project site and to assist in planning for avoidance, preservation in place, or, failing both, mitigation measures.

4. Remember that the lack of surface evidence of archaeological resources (including tribal cultural resources) does not preclude their subsurface existence.
 - a. Lead agencies should include in their mitigation and monitoring reporting program plan provisions for the identification and evaluation of inadvertently discovered archaeological resources per Cal. Code Regs., tit. 14, §15064.5(f) (CEQA Guidelines §15064.5(f)). In areas of identified archaeological sensitivity, a certified archaeologist and a culturally affiliated Native American with knowledge of cultural resources should monitor all ground-disturbing activities.
 - b. Lead agencies should include in their mitigation and monitoring reporting program plans provisions for the disposition of recovered cultural items that are not burial associated in consultation with culturally affiliated Native Americans.
 - c. Lead agencies should include in their mitigation and monitoring reporting program plans provisions for the treatment and disposition of inadvertently discovered Native American human remains. Health and Safety Code §7050.5, Public Resources Code §5097.98, and Cal. Code Regs., tit. 14, §15064.5, subdivisions (d) and (e) (CEQA Guidelines §15064.5, subs. (d) and (e)) address the processes to be followed in the event of an inadvertent discovery of any Native American human remains and associated grave goods in a location other than a dedicated cemetery.

If you have any questions or need additional information, please contact me at my email address:
Andrew.Green@nahc.ca.gov.

Sincerely,



Andrew Green
Cultural Resources Analyst

cc: State Clearinghouse



COUNTY OF
IMPERIAL

DEPARTMENT OF
PUBLIC WORKS

155 S. 11th Street
El Centro, CA
92243

Tel: (442) 265-1818
Fax: (442) 265-1858

Follow Us:



[www.facebook.com/
ImperialCountyDPW/](http://www.facebook.com/ImperialCountyDPW/)



[https://twitter.com/
CountyDpw/](https://twitter.com/CountyDpw/)

Public Works works for the Public



May 19, 2021

Imperial County Planning & Development Services
Mr. Jim Minnick, Director
801 Main Street
El Centro, CA 92243

RECEIVED

MAY 19 2021

IMPERIAL COUNTY
PLANNING & DEVELOPMENT SERVICES

Attention: Diana Robinson, Planner III

**SUBJECT: Vega SES 4 Solar Project – Apex Energy Solutions, LLC;
CUP 20-0020**

Located approximately 10 miles east of Calexico
APN's 059-300-015, 059-300-017, and 059-290-010

Dear Mr. Minnick:

This letter is in response to your submittal received by this Department on March 25, 2021 for the above mentioned project. The Applicant proposes to construct a 100-megawatt, alternating-current, solar photovoltaic energy generation facility on approximately 531.53 acres of land. The project would include a 100MW/400MWh battery storage facility.

Department staff has reviewed the package information and the following comments shall be Conditions of Approval:

1. The Applicant shall acquire proper easements from adjacent property owners for the installation of any proposed transmission lines.
2. All survey monuments, including those within the interior of the project, shall be protected, and their locations shall remain accessible to any surveyor throughout the duration of the project. Section 8774 of the Business and Professions Code, and Section 846.5 of the Civil Code, each provide the right of entry to utilize boundary evidence and perform surveys, without undue delay, to any person authorized to practice land surveying. The right of entry is not contingent upon prior notice.
3. The Applicant shall furnish a Drainage and Grading Plan/Study to provide for property grading and drainage control, which shall also include prevention of sedimentation of damage to off-site properties. The Study/Plan shall be submitted to the Department of Public Works for review and approval. The applicant shall implement the approved plan. Employment of the appropriate Best Management Practices (BMP's) shall be included (Per Imperial County Code of Ordinances, Chapter 12.10.020 B).
4. Based from the information provided on the project documents, it is assumed that County roads will not be used for site access during or after construction activities have

An Equal Opportunity / Affirmative Action Employer

C:\Users\Guadalupe Vasquez\AppData\Local\Microsoft\Windows\INetCache\Content.Outlook\CRR10WL0\CUP20-0020 - Approved.doc

PC ORIGINAL PKG

been completed. In the event that County roads are required for site access, the Applicant shall consult with this Department in advance for review and approval.

5. Access to sites shall be completed from public roads. The Applicant shall obtain written approval from any private owners or other agencies for the use of any non-public roads to access the sites. A copy of such written approval shall be submitted to this Department prior to the approval of grading plans.
6. Any unimproved access roads/routes between public roads and access gates shall be improved for all-weather access. Such all-weather improvements shall be completed as recommended by a Geotechnical Engineer licensed to practice in the State of California.
7. Each site shall have, as a minimum, one (1) primary Class 2 Base aggregate material driveway and one (1) emergency access Class 2 Base aggregate material driveway.
8. Access to project sites during and after construction is expected to be completed through private unpaved roads or private property.
 - a. The Applicant shall mitigate generation of dust caused by construction traffic as per Rule 805 – Paved and Unpaved Roads of the Imperial County Air Pollution Control District.

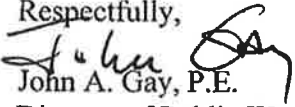
INFORMATIVE:

The following items are for informational purposes only. The Applicant is responsible to determine if the enclosed items affect the subject project.

- All solid and hazardous waste shall be disposed of in approved solid waste disposal sites in accordance with existing County, State and Federal regulations (Per Imperial County Code of Ordinances, Chapter 8.72).
- All on-site traffic areas shall be hard surfaced to provide all weather access for emergency vehicles. The surfacing shall meet the Department of Public Works and Fire/Office of Emergency Services (EOS) Standards as well as those of the Air Pollution Control District (APCD).
- The project may require a National Pollutant Discharge Elimination System (NPDES) permit and Notice of Intent (NOI) from the Regional Water Quality Control Board (RWQCB) prior to County approval of onsite grading plan (40 CFR 122.28).
- A Transportation Permit may be required from road agency(s) having jurisdiction over the haul route(s) for any hauls of heavy equipment and/or large vehicles which impose greater than legal loads on riding surfaces, including bridges. (Per Imperial County Code of Ordinances, Chapter 10.12 - OVERWEIGHT VEHICLES AND LOADS).

- Highline Canal Road is a private road. The Applicant may be required to mitigate dust generation on any portion of this road that may be used for construction and/or site access to comply with Imperial County Air Pollution Control District – RULE 805 PAVED AND UNPAVED ROADS (Adopted 11/08/2005; Revised 10/16/2012).
- Effective September 15, 2020, the State’s Mandatory Organic Waste Recycling Law (AB 1826 or Chapter 727, Statutes of 2014) decreased the threshold requiring all businesses and multi-dwelling facilities of 5 units or more generating two (2) cubic yards or more of solid waste per week to recycle their organic waste including landscape waste, wood waste, and food waste. Information about possible organics waste recycling services can be found at the CalRecycle site at:
<https://www.calrecycle.ca.gov/Recycle/Commercial/Organics/>
- As this project proceeds through the planning and the approval process, additional comments and/or requirements may apply as more information is received.

Should you have any questions, please do not hesitate to contact this office. Thank you for the opportunity to review and comment on this project.

Respectfully,

John A. Gay, P.E.
Director of Public Works



IID

A century of service.

www.iid.com

Since 1911

June 3, 2021

Ms. Diana Robinson
Planner III
Planning & Development Services Department
County of Imperial
801 Main Street
El Centro, CA 92243

RECEIVED
JUN 03 2021
IMPERIAL COUNTY
PLANNING & DEVELOPMENT SERVICES

SUBJECT: NOP of DEIR for the VEGA SES 4 Project; CUP Application No. 20-0020

Dear Ms. Robinson:

On May 6, 2021, the Imperial Irrigation District received from the Imperial County Planning & Development Services Department, a Notice of Preparation of Draft Environmental Impact Report for the VEGA SES 4 Solar Energy Project; Conditional Use Permit application no. 20-0020. The applicant, Apex Energy Solutions, LLC; proposes to develop a 100MW solar PV energy generation facility with a 100MW integrated battery storage on approximately 531.53 acres of land located between the U.S./Mexico border and the All-American Canal on the California side, 10 miles east of Calexico, CA (APNs 059-300-015-000, -300-017-000, -290-10-000). The project's electrical output would be conveyed through a proposed 92kV gen-tie line interconnection to the IID's 92kV "P" transmission line

The IID has reviewed the project information and found that the comments provided in the April 13, 2021 district letter (see attached letter) continue to apply.

Should you have any questions, please do not hesitate to contact me at 760-482-3609 or at dvargas@iid.com. Thank you for the opportunity to comment on this matter.

Respectfully,

Donald Vargas
Compliance Administrator II

Enrique B. Martinez – General Manager
Mike Pacheco – Manager, Water Dept.
Marilyn Del Bosque Gilbert – Manager, Energy Dept.
Constance Bergmark – Mgr. of Planning & Eng./Chief Elect. Engineer, Energy Dept.
Enrique De Leon – Asst. Mgr., Energy Dept., Distr., Planning, Eng. & Customer Service
Jamie Asbury – Assoc. General Counsel
Vance Taylor – Asst. General Counsel
Michael P. Kemp – Superintendent, Regulatory & Environmental Compliance
Laura Cervantes – Supervisor, Real Estate



IID

A century of service.

www.iid.com

Since 1911

April 13, 2021

Ms. Diana Robinson
Planner III
Planning & Development Services Department
County of Imperial
801 Main Street
El Centro, CA 92243

SUBJECT: Vega SES 4 Project; CUP Application No. 20-0020

Dear Ms. Robinson:

On April 5, 2021, the Imperial Irrigation District received from the Imperial County Planning & Development Services Department, a request for agency comments on Conditional Use Permit application no. 20-0020 for the Vega SES 4 Solar Energy Storage Project. The applicant, Apex Energy Solutions, LLC; proposes to develop a 100MW solar PV energy generation facility with a 100MW integrated battery storage on approximately 531.53 acres of land located between the U.S./Mexico border and the All-American Canal on the California side, 10 miles east of Calexico, CA (APNs 059-300-015-000, -300-017-000, -290-10-000). The project's electrical output would be conveyed through a proposed 92kV gen-tie line interconnection to the IID's 92kV "P" transmission line

The Imperial Irrigation District has reviewed the information and has the following comments.

1. If the project requires temporary construction or permanent electrical service at the distribution level, the applicant should be advised to contact Joel Lopez, IID Customer Project Development Planner, at (760) 482-3300 or e-mail Mr. Lopez at jflopez@iid.com to initiate the customer service application process. In addition to submitting a formal application (available for download at the district website <http://www.iid.com/home/showdocument?id=12923>), the applicant will be required submit a complete set of plans approved by the County of Imperial (in hardcopy and AutoCad formats) including site plan, plan & profile drawings, one-line diagrams, and electrical loads, panel size, voltage requirements, project schedule, and the estimated in-service date, in addition to the applicable fees, permits, easements and environmental compliance documentation pertaining to the provision of electrical service to the project. The applicant shall be responsible for all costs and mitigation measures related to providing electrical service to the project.

2. Distribution-rated electrical service is limited in the area. A circuit study may be required. Any improvements or mitigation identified in the circuit study to enable the provision of electrical service shall be the financial responsibility of the applicant.
3. To insure there are no impacts to IID facilities, applicant should submit project plans, including grading & drainage and fencing plans, to IID Water Department Engineering Services for review and comment prior to final project design and CUP approval. IID WDES can be contacted at (760) 339-9265 for further information on this matter.
4. The project may impact IID drains with project site runoff flows draining into IID drains. To mitigate impacts, the project may require a comprehensive IID hydraulic drainage system analysis. IID's hydraulic drainage system analysis includes an associated drain impact fee.
5. A construction storm water permit from the California Regional Water Quality Control Board is required before commencing construction and an industrial storm water permit from CRWQCB is required for the operation of the proposed facility. The project's Storm Water Pollution Prevention Plan and storm water permits from CRWQCB should be submitted to IID for review.
6. In order to obtain a water supply from IID for a non-agricultural project, the project proponent will be required to comply with all applicable IID policies and regulations and may be required to enter into a water supply agreement. Such policies and regulations require, among other things, that all potential environmental and water supply impacts of the project be adequately assessed, appropriate mitigation developed if warranted, including any necessary approval conditions adopted by the relevant land use and permitting agencies.
7. If IID implements a water allocation or apportionment program pursuant to the IID Equitable Distribution Plan, or any amending or superseding policy for the same or similar purposes, during all or any part of the term of said water supply agreement, IID shall have the right to apportion the project's water as an industrial water user. Information on how to obtain a water supply agreement can be found at the IID website <https://www.iid.com/water/municipal-industrial-and-commercial-customers> or by contacting Justina Gamboa-Arce, Water Resources Planner at (760) 339-9085 or jgamboarce@iid.com.
8. For information on procuring construction water, the applicant should contact IID South End Division at (760) 482-9800.

9. Any construction or operation on IID property or within its existing and proposed right of way or easements including but not limited to: surface improvements such as proposed new streets, driveways, parking lots, landscape; and all water, sewer, storm water, or any other above ground or underground utilities; will require an encroachment permit, or encroachment agreement (depending on the circumstances). A copy of the IID encroachment permit application and instructions for its completion are available at <https://www.iid.com/about-iid/department-directory/real-estate>. The IID Real Estate Section should be contacted at (760) 339-9239 for additional information regarding encroachment permits or agreements.
10. In addition to IID's recorded easements, IID claims, at a minimum, a prescriptive right of way to the toe of slope of all existing canals and drains. Where space is limited and depending upon the specifics of adjacent modifications, the IID may claim additional secondary easements/prescriptive rights of ways to ensure operation and maintenance of IID's facilities can be maintained and are not impacted and if impacted mitigated. Thus, IID should be consulted prior to the installation of any facilities adjacent to IID's facilities. Certain conditions may be placed on adjacent facilities to mitigate or avoid impacts to IID's facilities
11. The applicant may not use IID's canal or drain banks to access the project site. Any abandonment of easements or facilities shall be approved by IID based on systems (Irrigation, Drainage, Power, etc.) needs.
12. An IID encroachment permit is required to utilize existing surface-water drainpipe connections to drains and receive drainage service from the district. Surface-water drainpipe connections are to be modified in accordance with IID Water Department Standards.
13. The applicant should be advised to apply for and obtain two (2) encroachment permits for the proposed primary entrance, one from the U.S. Bureau of Reclamation and the second from IID. The applicant should not solely rely on the East Highline Canal check gate at the All-American Canal as the primary entrance to the project site. The IID Water Department reviews all encroachment applications on a case-by-case basis and the encroachment application will need to include detailed facility usage information at the time of applying for the encroachment permit. For further information on this matter, contact Hilda Romo, Senior Engineer, at (760) 339-9459 or at hmromo@iid.com.
14. Any new, relocated, modified or reconstructed IID facilities required for and by the project (which can include but is not limited to electrical utility substations, electrical transmission and distribution lines, water deliveries, canals, drains, etc.) need to be included as part of the project's CEQA and/or NEPA documentation,

Diana Robinson
April 13, 2021
Page 4

environmental impact analysis and mitigation. Failure to do so will result in postponement of any construction and/or modification of IID facilities until such time as the environmental documentation is amended and environmental impacts are fully analyzed. **Any and all mitigation necessary as a result of the construction, relocation and/or upgrade of IID facilities is the responsibility of the project proponent.**

Should you have any questions, please do not hesitate to contact me at 760-482-3609 or at dvargas@iid.com. Thank you for the opportunity to comment on this matter.

Respectfully,



Donald Vargas
Compliance Administrator II

Enrique B. Martinez – General Manager
Mike Pacheco – Manager, Water Dept.
Marilyn Del Bosque Gilbert – Manager, Energy Dept.
Constance Bergmark – Mgr. of Planning & Eng./Chief Elect. Engineer, Energy Dept.
Enrique De Leon – Asst. Mgr., Energy Dept., Distr., Planning, Eng. & Customer Service
Jamil Asbury – Assoc. General Counsel
Vance Taylor – Asst. General Counsel
Michael P. Kemp – Superintendent, Regulatory & Environmental Compliance
Laura Cervantes – Supervisor, Real Estate

PC ORIGINAL PKG

AIR POLLUTION CONTROL DISTRICT



June 4, 2021

RECEIVED

JUN 04 2021

IMPERIAL COUNTY
PLANNING & DEVELOPMENT SERVICES

Mr. Jim Minnick
Planning Director
801 Main Street
El Centro, CA 92243

SUBJECT: Initial Study 20-0029 and Notice of Preparation for a Draft Environmental Impact Report for Conditional Use Permit (CUP) 20-0020 for Vega 4 SES Solar Project by Apex Energy Solutions, LLC

Dear Mr. Minnick,

The Imperial County Air Pollution Control District (Air District) has reviewed Initial Study 20-0029 and the Notice of Preparation (NOP) for a Draft Environmental Impact Report (DEIR) for Conditional Use Permit (CUP) 20-0020 for the Vega 4 SES Solar Project. The proposed Project includes a 100 megawatt (MW) solar photovoltaic power generating facility and substation; a 200MW battery storage system; and a 92 kV intertie line. The Project would be located on 531 acres at 2849 East Highway 98 about 10 miles east of Calexico near the All American Canal next to the US-Mexican border, also described as Assessor's Parcel Numbers (APNs) 059-290-010-000, 059-300-015, and 059-300-017-000.

In previous comments dated April 6, 2021, the Air District outlined the expectations of a preliminary Air Quality Analysis that would be consistent with the Air District's California Environmental Quality Act (CEQA) Air Quality Handbook (ed. 2017). While the Air Quality and Greenhouse Gas Assessment ("AQGGA") addressed most elements of a comprehensive AQGGA, the Air District cannot concur with a Tier 1 finding based on inconsistencies in changes to the default settings of the California Emissions Estimator Model (CalEEMod) and misinterpretations of Air District rules and regulations.

In Section 2.3.2—Methodology, the statement "Project construction-generated air pollutant emissions were calculated using CalEEMod defaults..." is inconsistent with the notations in the CalEEMod output which show that the default for mobile percent road dust was changed from 50

to 90 and that the Construction default setting of 50 percent for paved roads was changed to 100 percent. Additionally, Table 2-6—Operational-Related Emissions gives “0” for PM₁₀ area emissions, while the CalEEMod output provides a different value for PM₁₀ Total Operational Emissions. As pointed out in previous comments, cumulative impacts are a major concern during operational phases of these projects, which is why an **Operational Dust Control Plan** must be part of the required mitigation measures.

The statement (pg. 15) that projects predicted to exceed Tier 1 thresholds require implementation of applicable ICAPCD standard mitigation measures to be considered less than significant is inconsistent with the Air District’s CEQA Air Quality Handbook. The Air District’s CEQA Handbook requires the use of standard mitigation measures for projects that fall below the level of significance. A subsequent misunderstanding of Air District rules is found in Section 2.3.3 regarding Rule 801—Construction and Earthmoving Activities. This rule goes beyond “reasonable precautions” and outlines specific steps that must be taken to reduce emissions of fugitive dust. Rule 801 is not a stand-alone rule, but is one of a collection of rules in Regulation VIII which together are designed to limit emissions of fugitive dust (PM₁₀) to 20% opacity.

The statement that the Project would not involve construction activities that would result in ozone (O₃) precursor emissions of ROG or NO_x is erroneous (pg. 21). The United States Environmental Protection Agency (USEPA) considers NO_x an ozone precursor.¹ As previously discussed, a **Construction Equipment List** will be required to identify NO_x emissions during the construction phase of the project. Please refer to the April 6, 2021 comments for details pertaining to the essential elements of such list.

Finally, the Air District recommends the use of the Mojave Desert Air Quality Management District’s Greenhouse Gas (GHG) significance thresholds rather than those of the South Coast Air Quality Management District. While climate may be similar, there is a noticeable difference in geography between the Riverside portion of the Salton Sea Air Basin and the rest of Imperial County. Thus, the GHG inventories for climate sectors such as transportation, energy and electric power for the MDAQMD are more representative of Imperial County.

¹ United States Environmental Protection Agency. Ground-level Ozone Basics. 2021 May 5. <https://www.epa.gov/ground-level-ozone-pollution/ground-level-ozone-basics>

The Air District looks forward to reviewing a revised Air Quality and Greenhouse Gas Assessment.

Air District rules and regulations can be found on our website at www.co.imperial.ca.us/AirPollution under the planning section. If any questions arise, please feel free to contact our office at (442) 265-1800.

Sincerely,



Curtis Blondell

APC Environmental Coordinator



Reviewed by,

Monjica N. Soucier

APC Division Manager



www.AgLandTrust.org
Location: 1263 Padre Drive | Salinas, CA
Mail Address: P.O. Box 1731 | Salinas, CA 93902
Tel.: 831.422.5868

Date: July 12, 2021 cc: Carlos Ortiz, Agriculture Commissioner
Imperial County, CA

To: Ramon Gonzalez, Business Development & Project Coordinator
ZGlobal

From: Sherwood Darington, Chief Executive Officer
Ag Land Trust

Subject: Vega SES Solar Energy Project
Agricultural Conservation Easement(s), Imperial County, CA

Dear Ramon,

Thank you for considering utilizing Ag Land Trust in your efforts to secure the conservation easement mitigation requirement for the solar energy project in Imperial County, CA.

The Conditional Use Permit (CUP) #17-0001 requires that the conservation easement conforms with the requirements of the Department of Conservation and the Department of Conservation requirement includes a forever in perpetuity timeframe.

If your project conforms with the Department of Conservation requirements and if we can be of further assistance, please reach out to us.

PC ORIGINAL PKG

July 21, 2021

Anika Larson
ZGlobal, Inc.
604 Sutter Street, Suite 250
Folsom, CA 95630

RE: Visual Impact Assessment Letter Report– Vega SES 4 Project

Dear Ms. Larson:

The purpose of this Visual Impact Assessment (VIA) letter report is to evaluate the potential visual impacts associated with the construction and implementation of the Vega SES 4 Solar Energy Storage Project located in Imperial County, California. This VIA includes an analysis and description of the existing visual setting and potential visual impacts. If the Project results in any adverse visual impacts, the purpose of the VIA is also to propose measures to minimize those impacts.

1.0 PROJECT DESCRIPTION, LOCATION, AND SETTING

The Project is located in south-central Imperial County between the California/Mexico border and the All-American Canal (Aqueduct). Figures 1 and 2 depict the Project location and vicinity (Attachment A).

Vega SES 4 is located on Imperial County Assessor's Parcel Numbers (APNs) 059-300-015-000 (approximately 301.73 acres), 059-300-017-000 (approximately 148.88 acres), and 059-290-010-000 (approximately 80.92 acres). All Project parcels are designated as "Agriculture" in the Imperial County General Plan and are zoned A-3-RE (Heavy Agriculture with a Renewable Energy Overlay).

Project Characteristics

Solar panels would use either thin film or crystalline solar photovoltaic (PV) technology modules mounted either on fixed frames or horizontal single-axis tracker (HSAT) systems. The fixed frame PV module arrays would be mounted on racks that would be supported by driven piles. The fixed-frame racks would be secured at a fixed tilt of 20 degrees to 30 degrees from horizontal facing a southerly direction. Current Project designs would have individual PV modules, mounted two high on a fixed frame, providing a two-foot ground clearance and resulting in the tops of the panels at approximately 7.5 feet above the ground. The fixed PV modules would be arranged in arrays spaced approximately 15 to 25 feet apart (pile-to-pile) to maximize performance and to allow access for panel cleaning (if necessary). These arrays would be separated from each other and the perimeter security fence by up to 30-foot wide interior roads. If HSAT technology is used, the PV modules would rotate around the north-south HSAT axis so that the PV modules would continue to face the sun as the sun moves across the sky throughout the day. The PV modules would reach their maximum height (up to nine (9) feet above the ground, depending on the final design) at both sunrise and sunset, when the HSAT is rotated to point the modules at the rising or setting sun. At noon, or when stowed during high winds, when the HSAT system is rotated so that the PV

modules are horizontal, the nominal height would be about six feet above the ground, depending on the final design. The individual PV systems would be arranged in large arrays by placing them in columns spaced approximately ten feet apart to maximize operational performance and to allow access for panel cleaning and maintenance. Current Project designs would have individual HSAT PV modules, each approximately two feet wide by four feet long (depending on the specific PV technology selected), mounted on a frame which is attached to an HSAT system. These HSAT arrays would be separated from each other and the perimeter security fence by up to 30-foot wide roads, consistent with County emergency access requirements.

Construction activities would primarily involve demolition and grubbing; grading at the Project site to establish access roads and pads for electrical equipment (inverters and step-up transformers); trenching for underground electrical collection lines; and the installation of solar equipment and security fencing. Stormwater management facilities would be constructed internally within the site and would consist of basins and infiltration areas. Dust generated during construction would be controlled by watering and, as necessary, the use of other dust suppression methods and materials accepted by the Imperial County Air Pollution Control District (ICAPCD) or the California Air Resources Board (CARB). A temporary, portable construction supply container would be located at the Project site at the beginning of construction and removed at the end of construction. Onsite parking would be provided for all construction workers.

Once construction is completed the Project would be remotely controlled. No employees would be based at the Project site. Primary security-related monitoring would be done remotely. Security personnel may conduct unscheduled security rounds and would be dispatched to the site in response to a fence breach or other alarm. Site maintenance workers may access the Project site periodically to clean the panels and maintain the equipment and Project area. The public would not have access to the facility. Access to the Project site would be infrequent and limited to authorized personnel.

Conceptual plans for the Vega SES4 project are provided in Attachment B.

2.0 VISUAL IMPACT ASSESSMENT METHODOLOGY

The following steps were taken in analyzing the visual impacts of the proposed Vega SES 4Solar and Battery Storage Project.

1. Describe the existing visual setting, including any sensitive viewer groups (i.e., baseline conditions);
2. Describe the visual appearance of the Project. Key viewpoints were not selected to represent the typical views from the public right-of-way because the nearest public right-of-way is located approximately 0.5 mile away;
3. Assess the visual changes that would be introduced by the Project and the viewer response based on defined attributes which are neither good nor bad. Change in visual character cannot be described as having good or bad attributes until compared with viewer responses to the change;
4. Determine the degree of visual impact;
5. Proposed methods to minimize adverse impacts

Evaluation of potential visual impacts resulting from implementation of the Proposed Project is based on the following criteria:

Change in Visual Quality. The difference in visual quality between the existing environmental setting and post-Project condition is considered visual quality change. Those changes are identified by studying site plans, which provide information on the various elements that will be removed from and incorporated into the current viewshed and the degree of change in the existing setting. The plans help to understand the potential changes in visual quality of the site after implementation of the Project. Physical changes are analyzed in relation to vividness, intactness, and unity of the proposed project conditions. Sensitivity of various viewer groups is evaluated to measure response to the visual quality changes.

Impacts to Visual Resources. Visual resources from both the natural and built environments can enhance the visual character and aesthetic quality of an area. The Project limits and vicinity were studied for visual resources. Visual resources can be associated with local events and history that represent and enhance the visual character of the local area. A project that substantially alters important visual resources can result in significant visual impacts. Mitigation is typically implemented to remove or minimize significant visual impacts.

Light, Glare, Shade, and Shadow. The existing light environment serves as a baseline to conduct light analysis and compare potential impacts caused by the introduction of the Proposed Project. Impacts relating to light, glare, shade, and shadow were examined during field observations and by the photographs to help establish light conditions during various times of the day and night and estimate the potential changes in the environment from Project implementation. New light sources and reduction or elimination of light could be considered impacts that could change the natural environmental setting of a project site. Impacts are evaluated based on how much existing conditions change, the degree of those changes, and the sensitivity of the affected environment.

Compatibility with Visual Policies. General Plans, Specific Plans, and other regulations or policies relating to visual resources and setting at the project site have been identified, reviewed, and used in the preparation of this analysis. Proposed visual changes that conflict with the adopted County guidelines could be considered a significant impact.

3.0 LOCAL VISUAL RESOURCE POLICIES

County of Imperial General Plan

Circulation and Scenic Highways Element

The Imperial County General Plan Circulation and Scenic Highways Element provides information about the transportation needs of the County and the various modes to meet these needs and provides for the movement of goods and people, including pedestrian, bicycles, transit, train, air and automobile. This Element is also intended to provide a plan to accommodate a pattern of concentrated and coordinated

growth and to provide a means of protecting and enhancing scenic resources within both rural and urban scenic highway corridors.

The potential designation of Scenic Highway has been placed on specific roadways in the County and may be added to others in the future. This designation is intended to protect and enhance the County's scenic aesthetic resources which are visible from major County and State routes. As identified in the Circulation and Scenic Highways Element, four State routes within the County have the potential for designation as Scenic Highways:

- **Interstate 8 (I-8):** The initial segment for future Scenic Highway Designation status lies between the San Diego County line and its junction with State Route 98 (SR-98). This segment known as Mountain Springs Grade has a long, rapid elevation change, remarkable rock and boulder scenery, and plant life variations.
- **State Route 78 (SR-78):** The portion of SR-78 from the junction with State Route 86 (SR-86) to the San Diego County line is eligible for future Scenic Highway Designation. The area is considered scenic because of its desert characteristics and view of Salton Sea.
- **State Route 111 (SR-111):** SR-111 travels along the northeast shore of the Salton Sea and is eligible for future Scenic Highway Designation from Bombay Beach to the County line. The drive along this body of water is a study in primitive beauty and an interesting and startling anomaly. The contrast between the flat, wide Salton Sea with its sandy beach and the rugged rise of the Chocolate Mountains has many variations. The panoramic view of the opposite (southwest) shore and its backdrop of mountains is also a sight of pre-historic beauty.
- **Borrego-Salton Seaway:** County Highway S-22 is also known as the Borrego-Salton Seaway. It begins in Salton City and ends at the community of Borrego Springs in San Diego County. Along its route, is Clay Point, located a mile and half west of SR-86, which is a formation ring above a flat desert shore which shows the bed of pre-Columbian Lake Cahuilla. Three and a half miles farther west, the Anza Verde Wash parallels the Borrego-Salton Seaway with uniquely scenic desert landforms and vegetation.

The Circulation and Scenic Highways Elements contains the following objectives for the preservation of environmental and scenic amenities of the area along potential Scenic Highways.

- Objective 4.1 Establish various systems of scenic recreational travel utilizing multiple transportation modes.
- Objective 4.2 Preserve, enhance, and protect Imperial County's scenic resources by the removal of illicit billboards from scenic areas and restrictions on new off-site sign construction visible from designated scenic highways.
- Objective 4.3 Protect areas of outstanding scenic beauty along any scenic highways and protect the aesthetics of those areas.
- Objective 4.4 Acquire scenic easements from private owners when required.
- Objective 4.5 Develop standards for aesthetically valuable sites. Design review may be required so that structures, facilities, and activities are properly merged with the surrounding environment.

Conservation and Open Space Element

The Imperial County General Plan Conservation and Open Space Element is a conservation guide for the protection of regional aesthetics. This Element identifies goals and policies to ensure the managed use of environmental resources to prevent limiting the range of resources available to future generations. The Conservation and Open Space Element identifies scenic visual resources within the County which include the deserts, sand dunes, mountains, and the Salton Sea.

Desert areas include the Yuha Desert, West Mesa, lower Borrego Valley, East Mesa, and Pilot Knob Mesa. Within the desert areas, there are unique geologic features which add scenic value to the natural landscape and desert vegetation which results in springtime blooms of desert flowers in the springtime. The Algodones Dunes are the largest sand dunes in California covering approximately 160 square miles and are a well-known landmark to County residents and highway travelers. These dunes are a significant visual resource due to their unique scenic qualities, historic features, and prominent visibility to a large number of viewers.

As described in this Element, scenic mountains within the County include the eastern foothills of the Peninsular Range along the County's southwest side consisting of the In-Ko-Pah or Jacumba Mountains, Coyote Mountains, and Fish Creek Mountains. East of this area is Mount Signal located along the international border on the eastern edge of the Yuha Desert, west of Calexico. The southeast foothills of the San Rosa-San Jacinto Mountain are a prominent feature from SR-86. The Superstition Mountains and Superstition Hills, located in West Mesa southeast of the lower Borrego Valley and west of Westmorland and Brawley, are visible from I-8 west of El Centro and from SR-86 between El Centro and the Salton Sea. In the northeastern part of the County, the Chocolate Mountains stretch northwest by southeast between Riverside County and the Colorado River. Portions of these mountain areas are designated by the Bureau of Land Management (BLM) as Wilderness Areas, part of the National Wilderness Preservation System. The intention of this designation is to secure natural areas for the public purposes of recreation, scenic, scientific, educational, conservation, and historical use.

The Salton Sea is located in the northwestern portion of the County and encompasses approximately 376 square miles. This body of water has been sustained by agricultural drainage from the Imperial, Coachella, and Mexicali valleys, rainfall, storm runoff from surrounding mountains, and groundwater inflow. The Salton Sea provides migrating and winter habitat for waterfowl and other birds and is a unique visual resource because of its size, location in a desert environmental, and its value for wildlife.

Anza-Borrego Desert State Park, located on the eastern side of San Diego County with portions extending into Imperial Count, features washes, wildflowers, palm groves, cacti, sweeping vistas, and hiking trails.

The Conservation and Open Space Element also identifies scenic vista points which include the Osborne Overlook and Juan Bautista de Anza Overlook. The Osborne Overlook offers scenic views of the Imperial Sand Dunes Recreational Area, North Algodones Dunes Wilderness, and surrounding area while the Juan Bautista de Anza Overlook provides a view of the Yuha Basin and surrounding landscape.

The Conservation and Open Space Element contains the following objectives for the preservation of environmental and scenic amenities of the area along potential Scenic Highways (County of Imperial 2016).

Objective 5.1 Encourage the conservation and enhancement of the natural beauty of the desert and mountain landscape.

Objective 5.2 Utilize the Code Enforcement process to eliminate visually dilapidated buildings that impact the visual character of rural communities.

4.0 BASELINE VISUAL CONDITIONS

A view is defined by the topography, development, activity, and vegetation. The Project area was observed and mapped to identify existing visual resources in the area and viewer groups. The Project area was photodocumented during a visual field survey in September 2020 to record existing visual conditions in the Project vicinity and surrounding area. Land uses and topography were assessed to characterize the physical environment and establish the existing visual setting as described below.

Topography

Topography is relatively flat with elevations ranging between 11 meters (38 feet) and 18 meters (60 feet) above mean sea level. Adjacent land uses include agricultural and ranch land to the north and west, the U.S./Mexico border to the south, and undeveloped land to the east. The All-American Canal travels northeast to southwest, north of the Project site.

Land Use

Surrounding lands are designated as "Agriculture" by the Imperial County General Plan and are zoned A-3-RE (Heavy Agriculture with a Renewable Energy Overlay). Pursuant to Section 91703.02 (CONDITIONAL USE PERMITS), Renewable Energy Projects must be located within the Renewable Energy Overlay Zone and may be permitted only through the issuance of a Conditional Use Permit (CUP) as approved by the Approving Authority unless otherwise allowed by applicable law.

Vegetation

The majority of the Project site consists of creosote bush – white bursage scrub (disturbed), disturbed lands, and tamarisk thickets. Small portions of the Project site along the eastern perimeter and centrally within the site contain areas of creosote bush scrub. The remainder of the Project site on the western end consists of alkali weed – salt grass playas and sinks and arrow weed thickets (ECORP 2020).

Historic Resources

A records search for historic resources was conducted in September 2020 at the South Coastal Information Center (SCIC) at San Diego State University. The records search included a review of all recorded historic and prehistoric archaeological sites within a one-mile radius of the Project area, as well as a review of known cultural resource surveys and excavation report. Six previously recorded resources

were located within one mile of the Project site and one cultural resource was recorded within the Project site. Sixteen newly identified resources are located within the Project site and with the presence of one previously recorded resource, there are a total of 17 cultural resources present onsite. Seven of these cultural resources are located in the western portion of the Project site and will be avoided by the Project. (ECORP 2021). The remaining ten resources within the Project site that cannot be avoided by implementation of the Project include five sites (three historic period and two pre-contact) and five isolates. Subsurface testing and archival research determined that the five sites within the Project site are not eligible for the National Register of Historic Places (NRHP). The five isolates within the Project site were also evaluated and found not eligible for the NRHP and CRHR.

5.0 VISUAL CHANGE AND VISUAL IMPACT EVALUATION

Evaluation of potential visual impacts resulting from implementation of the proposed Vega SES 4 Project is based on the following criteria:

- **Change in Visual Quality.** The difference in visual quality between the existing environmental setting and post-Project condition is considered visual quality change. Those changes are identified by studying engineering plans, which provide information on the various elements that will be replaced and/or reconstruction into the current viewshed and the degree of change in the existing setting.
- **Impacts to Visual Resources.** Visual resources from both the natural and built environments can enhance the visual character and aesthetic quality of an area. The Project limits and vicinity were studied for visual resources. Visual resources can be associated with local events and history that represent and enhance the visual character of the local area. A project that substantially alters important visual resources can result in adverse visual impacts. Mitigation is typically implemented to remove or minimize adverse visual impacts.
- **Light, Glare, Shade, and Shadow.** The existing light environment serves as a baseline to conduct light analysis and compare potential impacts caused by introduction of one of the alternatives. Impacts relating to light, glare, shade, and shadow were examined during field observations and by the photographs to help establish light conditions during various times of the day and night and estimate the potential changes in the environment from project implementation. New light sources and reduction or elimination of light could be considered impacts that could change the natural environmental setting of a project site. Impacts are evaluated based on how much the existing conditions change, the degree of those changes, and the sensitivity of the affected environment.
- **Compatibility with Visual Policies.** General Plans, Specific Plans, and other regulations or policies relating to visual resources and setting at the project site have been identified, reviewed, and used in preparation of this assessment. Proposed visual changes that conflict with the adopted agency guidelines could be considered an adverse impact.

Available public right of way in the vicinity of the Project site includes CA State Route (SR) 98 and Vencil Road. Visibility of the site from the public right of way is obstructed from CA State Route 98 by a berm. Visibility of the project site from Vencil Road is limited due to a distance of approximately 0.5 mile. No key observation points are proposed for this analysis. Surrounding property is privately owned and viewers

would be limited to property owners, employees servicing/maintaining Imperial Irrigation District (IID) facilities (e.g., the canal), and border patrol personnel.

The overall character and experience for the viewer would change substantially with implementation of the Project. The main physical change that would occur is the complete removal of vegetation and grading of the Project site to accommodate the construction of solar apparatus and security fencing. Other facilities proposed such as roads, pads, underground utilities, and stormwater facilities would not be readily visible as these facilities would be at or below grade. There are no scenic resources located in the Project vicinity, no scenic vista points are identified in the County General Plan, and none of the roadways in the project vicinity are designated scenic highways or roadways.

The proposed PV module frames when installed on pads would be approximately 7.5 feet in height and the proposed security fencing would be approximately 6 feet in height. Currently, the existing vegetation on the project site consist of large dense bushes and trees; however, there are no existing obstructions of identified scenic resources as none are located in the Project vicinity and visible from surrounding areas.

Implementation of the proposed project would change the natural conditions of the site to a solar energy generation and battery storage facility. Onsite vegetation would be completely removed, and the site would be graded to accommodate the installation of the PV module frames in arrays. The Imperial County General Plan has designated the Project site as "Agriculture" and is zoned A-3-RE (Heavy Agriculture with a Renewable Energy Overlay). Agricultural uses within the Project are fallow and have not been actively used for agriculture for many years. Renewable energy projects must be located within the Renewable Energy Overlay Zone and may be permitted only through the issuance of a Conditional Use Permit (CUP). With a CUP, the Project would be consistent with the intended use of the land. Although Project implementation would result in the conversion of a naturally vegetated area with energy-related facilities, agricultural vegetated areas are not considered to be scenic resources by the County of Imperial.

Construction Impacts

Construction of the Proposed Project would result in temporary visual changes due to construction activities. Potential short-term construction impacts would result from the proposed Project through the presence of construction equipment and materials. Upon completion of construction, equipment and construction materials would no longer be present.

Light, Glare, Shade, and Shadow

Minimal lighting would be required for operations and would be limited to safety and security functions. All lighting will be directed downward and shielded to focus illumination on the desired areas only and to minimize light trespass in accordance with applicable County requirements. If additional lighting should be required for nighttime maintenance, portable lighting equipment would be used. The Project is not anticipated to create a new source of substantial light which would adversely affect nighttime views in the Project area.

The Project would involve the installation of PV solar arrays which have low reflectivity. Solar PV modules are specifically designed to reduce reflection as any reflected light cannot be converted into energy. Research has shown that reflectivity from PV panels are similar to reflections from water (National Renewable Energy Laboratory 2020). Therefore, the PV panels would not create a significant source of glare during sunlight hours. The Project would not use other reflective materials such as fiberglass, aluminum or vinyl/plastic siding, galvanized products, and brightly painted steel roofs that have the potential to create on- and off-site glare.

Shade and shadow effects would be introduced within the Project site due to the placement of PV modules in arrays. However, due to the height of the proposed apparatus at 7.5 feet and the perimeter fencing at 6 feet, the effects of shade and shadow would not encroach into areas offsite for extended periods of time that would result in significant shade and/or shadow impacts.

Scenic Highways

There are no designated Caltrans scenic highways in the vicinity of the Proposed Project. None of the scenic highways identified in the County's General Plan Circulation and Scenic Highways Element are located in the Project vicinity. Interstate 8 is located over 5 miles away to the north. There would be no impact to scenic resources within a State or locally designated scenic highway.

Historic Resources

As previously identified, sixteen newly identified resources are located within the Project site and with the presence of one previously recorded resource, there are a total of 17 cultural resources present onsite. The remaining ten resources within the Project site that cannot be avoided by implementation of the Project include five sites (three historic period and two pre-contact) and five isolates. Subsurface testing and archival research determined that the five sites within the Project site are not eligible for the NRHP. The five isolates within the Project site were also evaluated and found not eligible for the NRHP and CRHR. Further none of the cultural resources identified within the Project site are visible from public vantage points, there would be no visual impact to historic resources.

Visual Resource Policies

Scenic features, vistas, or landforms identified by the County of Imperial would not be significantly affected by construction and implementation of the Project. The Proposed Project would not conflict with specific policies identified in the Circulation and Scenic Highways Element or Open Space and Conservation Element of the County's General Plan. No impacts associated with incompatibility with visual resource policies would occur under the Proposed Project.

Summary of Impacts

During the construction phase, the presence of construction equipment and materials would not have a permanent, long-term impact on the visual environment. Upon completion of the Project, areas that were

cleared for construction staging would be converted to a new energy generating and storage facilities or returned to their existing condition.

No obstruction of existing scenic resources would occur with Project implementation as none existing in the Project vicinity.

Minimal lighting would be required for operations and would be limited to safety and security functions and would adhere to County lighting requirements. The Project is not anticipated to create a new source of substantial light which would adversely affect nighttime views in the Project area. Shade and shadow effects would not be a significant impact to adjacent properties due to the height of the proposed apparatus and security fencing.

No impacts to NRHP- or CRHR-eligible historic resources would occur with Project implementation.

The Project would be consistent with the County General Plan. No impacts associated with incompatibility with visual resource policies would occur under the Proposed Projects.

Sincerely,



Senior Environmental Planner
ECORP Consulting, Inc.

Attachments

Attachment A: Figures

Attachment B: Conceptual Plans



REFERENCES

County of Imperial. 2008. *County of Imperial General Plan Circulation and Scenic Highways Element*. January

_____. 2016. *County of Imperial General Plan Circulation and Scenic Highways Element*. March.

_____. 2016. *County of Imperial General Plan Conservation and Open Space Element*. March.

ECORP. 2020. *Biological Technical Report Vega SES 4 Solar Projects*. November

_____. 2020. *Cultural Resources Inventory Vega SES 4 Solar Energy Project*. November

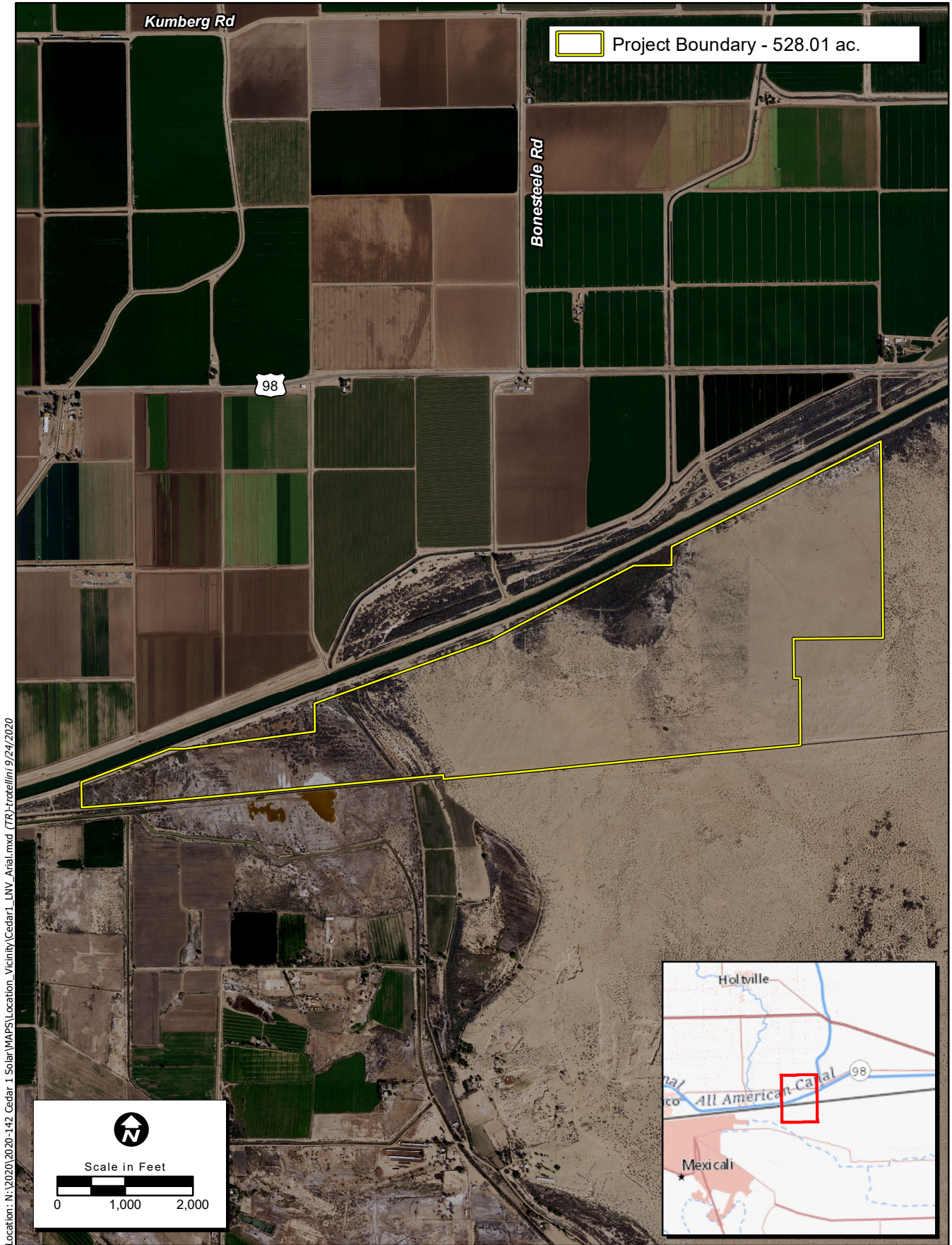
_____. 2021. *Cultural Resources Inventory, Testing, and Evaluation Report Vega SES 4 Solar Energy Project*. January

National Renewable Energy Laboratory. 2020. *Research and Analysis Demonstrate the Lack of Impacts of Glare from Photovoltaic Modules*. Website: <https://www.nrel.gov/state-local-tribal/blog/posts/research-and-analysis-demonstrate-the-lack-of-impacts-of-glare-from-photovoltaic-modules.html>, Accessed March 25, 2021.

LIST OF ATTACHMENTS

Attachment A – Figures

Attachment B – Conceptual Plans

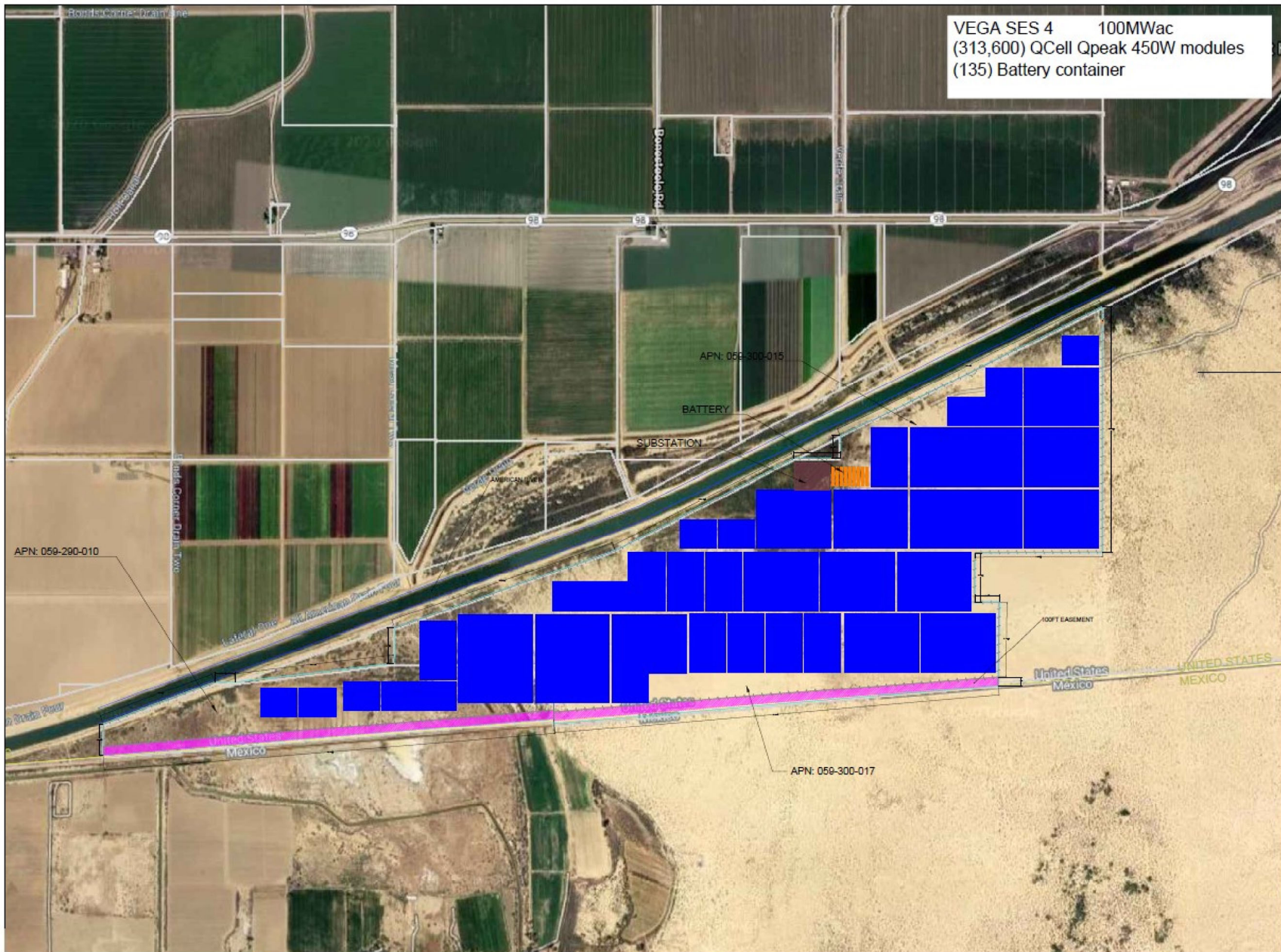


Location: N:\2020\2020-142_Cedar_1_Solar\WAPS\Location_Vicinity\Cedar1_LINV_Arial.mxd (TR)-truelin\9/24/2020

Map Date: 9/24/2020
 Service Layer Credits:
 Photo Source: NAIP (2018)

Figure 1. Project Location and Vicinity

2020-142 Vega SES 4



VEGA SES 4 100MWac
 (313,600) QCell Qpeak 450W modules
 (135) Battery container

VEGA SES 4

CONFIDENTIAL DOCUMENTS
 THE INFORMATION SHOWN ON THIS DRAWING IS STRICTLY CONFIDENTIAL AND IS SUPPLIED WITH THE UNDERSTANDING THAT IT WILL BE HELD CONFIDENTIAL AND NOT DISCLOSED TO THIRD PARTIES WITHOUT THE WRITTEN CONSENT OF SOLARIAL, INC.

REV.	BY	DESCRIPTION	DATE	APPROVED BY
0	RD	PRELIMINARY	08/17/20	JA

1 inch
 Scale to Contain 24x36" Plot

Apex SOLUTIONS
 604 SLUTTER ST, STE 250
 FOLSOM, CA 95630
 Phone : 916.985.9461
 Fax: 916.985.9467

"THESE DRAWINGS AND SPECIFICATIONS HAVE BEEN PREPARED BY SOLARIAL, INC. FOR THEIR EXCLUSIVE USE IN ACCORDANCE WITH SECTION 4937.3 OF THE 2015 PROFESSIONAL ENGINEERING ACT OF THE STATE OF CALIFORNIA"

SHEET TITLE:
SITE PLAN

DRAWN BY:	RD	DRAWING NO.
CHECKED:	JA	C-000
SCALE:	1/8" = 1'-0"	
JOB NO.		
DATE:	1	REV NO. 1

PC ORIGINAL PKG

**Air Quality and Greenhouse Gas Emissions
Assessment
for the
VEGA SES 4 Solar Energy Project**

County of Imperial, California

Prepared For:

ZGlobal/APEX Energy Solutions
750 W. Main Street
El Centro, CA 92243

Prepared By:



ECORP Consulting, Inc.
ENVIRONMENTAL CONSULTANTS

2525 Warren Drive
Rocklin, California 95677

October 2022

CONTENTS

1.0	INTRODUCTION	1-4
1.1	Project Overview.....	1-4
1.2	Project Location.....	1-4
2.0	AIR QUALITY	2-1
2.1	Air Quality Setting.....	2-1
2.1.1	Salton Sea Air Basin.....	2-1
2.1.2	Criteria Air Pollutants.....	2-2
2.1.3	Toxic Air Contaminants.....	2-5
2.1.4	Ambient Air Quality.....	2-5
2.1.5	Sensitive Receptors.....	2-7
2.2	Regulatory Framework.....	2-7
2.2.1	Federal	2-7
2.2.2	State.....	2-8
2.2.3	Local.....	2-10
2.3	Air Quality Emissions Impact Assessment.....	2-11
2.3.1	Thresholds of Significance	2-11
2.3.2	Methodology	2-12
2.3.3	Impact Analysis.....	2-13
3.0	GREENHOUSE GAS EMISSIONS	3-1
3.1	Greenhouse Gas Setting.....	3-1
3.1.1	Sources of Greenhouse Gas Emissions	3-2
3.2	Regulatory Framework.....	3-3
3.2.1	State.....	3-3
3.3	Greenhouse Gas Emissions Impact Assessment.....	3-4
3.3.1	Thresholds of Significance	3-4
3.3.2	Methodology	3-6
3.3.3	Impact Analysis.....	3-6
4.0	REFERENCES.....	4-1

LIST OF TABLES

Table 2-1. Criteria Air Pollutants- Summary of Common Sources and Effects.....	2-3
Table 2-2. Summary of Ambient Air Quality Data.....	2-6
Table 2-3. Attainment Status of Criteria Pollutants in the Imperial County Portion of the SSAB	2-7

Table 2-4. ICAPCD Significance Thresholds – Pounds per Day.....2-12

Table 2-5. Unmitigated Project Construction-Generated Emissions2-14

Table 2-6. Mitigated Project Construction-Generated Emissions.....2-17

Table 2-7. Operational-Related Emissions (Regional Significance Analysis)2-18

Table 2-8. Proposed Project Displaced Criteria Pollutant Emissions (Tons)2-20

Table 3-1. Greenhouse Gases 3-2

Table 3-2. Construction-Related Greenhouse Gas Emissions..... 3-7

Table 3-3. Operational-Related Greenhouse Gas Emissions..... 3-8

Table 3-4. Life-Cycle Greenhouse Gas Emissions for Various Types of Energy Generators 3-9

Table 3-5. Proposed Project Displaced GHG Emissions (Metric Tons).....3-10

LIST OF ATTACHMENTS

- Attachment A – CalEEMod Output Files Criteria Air Pollutants
- Attachment B – Renewable Energy Emissions Displacement
- Attachment C – CalEEMod Output Files Greenhouse Gas Emissions

LIST OF ACRONYMS AND ABBREVIATIONS

°F	Degrees Fahrenheit
µg/m ³	Micrograms per cubic meter; ppm = parts per million
1992 CO Plan	1992 Federal Attainment Plan for Carbon Monoxide
AB	Assembly Bill
AC	Alternating Current
AQMD	Air Quality Management District
BESS	Battery Electric Storage System
CAA	Clean Air Act
CAAQS	California Ambient Air Quality Standards
CalEEMod	California Emissions Estimator Model
Caltrans	California Department of Transportation
CAPCOA	California Air Pollution Control Officers Association
CARB	California Air Resources Board
CCAA	California Clean Air Act
CCR	California Code of Regulations
CEQA	California Environmental Quality Act
CH ₄	Methane
CO ₂	Carbon dioxide
CO ₂ e	Carbon dioxide equivalent
County	Imperial County
CUP	Conditional Use Permit
DPM	Diesel particulate matter

LIST OF ACRONYMS AND ABBREVIATIONS

EO	Executive Order
GHG	Greenhouse gas
GWP	Global warming potential
ICAPCD	Imperial County Air Pollution Control District
IID	Imperial Irrigation District
IPCC	Intergovernmental Panel on Climate Change
kV	Kilovolt
MDAQMD	Mojave Desert Air Quality Management District
MW	Megawatt
MWAC	Megawatt Alternating Current
N ₂ O	Nitrous oxide
NAAQS	National Ambient Air Quality Standards
NO ₂	Nitrogen dioxide
NO _x	Nitric oxides
O ₃	Ozone
PM	Particulate matter
PM ₁₀	Coarse particulate matter
PM _{2.5}	Fine particulate matter
POI	point of interconnection
ppb	Parts per billion
Project	VEGA SES 4 Solar Energy Project
PV	Photovoltaic
ROGs	Reactive organic gases
RE	Renewable Energy
SB	Senate Bill
SCAQMD	South Coast Air Quality Management
SIP	State Implementation Plan
SO ₂	Sulfur dioxide
SO _x	Sulfur oxides
SR	State Route
SRA	Source receptor area
SSAB	Salton Sea Air Basin
TACs	Toxic air contaminants
USEPA	U.S. Environmental Protection Agency
VOC	Volatile organic compound
VMT	Vehicle Miles Traveled

1.0 INTRODUCTION

This report documents the results of an assessment of both air quality and greenhouse gas (GHG) emissions completed for the VEGA SES 4 Solar Energy Project (Project), which includes the construction of a 100-megawatt (MW) alternating current (AC) solar field on approximately 451 acres of vacant land on two parcels in Imperial County, California (APN 059-300-015, 301.73 acres; APN 059-300-017, 148.88 acres). This assessment was prepared using methodologies and assumptions recommended in the rules and regulations promulgated by the Imperial County Air Pollution Control District (ICAPCD). Regional and local existing conditions are presented, along with pertinent emissions standards and regulations.

1.1 Project Location

The Project Site is located on approximately 451 acres of privately-owned land in the southernmost portion of Imperial County, California (see Figures 1-1 and 1-2). The Project Site is between the U.S./Mexico international border and the All-American Canal, on the California side. It is approximately 10 miles east of the City of Calexico in Sections 10, 11, 14, 15, and 16 within Township 17 South, and Range 16 East of the San Bernardino Base and Meridian of the Bonds Corner topographic 7.5-minute quadrangle. The irregular shaped Project Site is bound by undeveloped land, portions of which have been disturbed associated with previous agricultural-related activities to the west and east, the All-American Canal running southwest on the northern border of the Project Site, and the U.S./Mexico international border to the south. The Project Site is currently characterized by flat and undeveloped land, portions of which have been disturbed associated with previous agricultural-related activities.

In 2016, the County adopted the Imperial County Renewable Energy and Transmission Element, which includes an RE Zone (RE Overlay Map). This General Plan element was created as part of the California Energy Commission Renewable Energy Grant Program to amend and update the County's General Plan to facilitate future development of renewable energy projects. The County Land Use Ordinance, Division 17, includes the RE Overlay Zone, which authorizes the development and operation of renewable energy projects with an approved conditional use permit (CUP). The RE Overlay Zone is concentrated in areas determined to be the most suitable for the development of renewable energy facilities while minimizing the impact on other established uses. As shown on Figure 1-1, the Project Site is located within the RE Overlay Zone. Therefore, no General Plan Amendment or Rezone would be required to implement the Proposed Project.

1.2 Project Overview

The Proposed Project consists of three primary components: 1) solar energy generation equipment and associated facilities including a substation and access roads (herein referred to as "solar energy facility"); 2) battery energy storage system (BESS); 3) generator intertie (gen-tie) that would connect the proposed onsite substation to the point of interconnection at the existing Imperial Irrigation District (IID) 92 kilovolt "P" line. The first component, a 100 MW AC photovoltaic (PV) solar energy facility, would span the majority of the Project Site. The BESS component would be located within the northeastern portion of the solar energy facility site and span two acres (APN 059-300-015). The electrical energy produced by the Project would be conducted through the Project's interconnection facilities to the proposed 92 kilovolt (kV) gen-tie line and

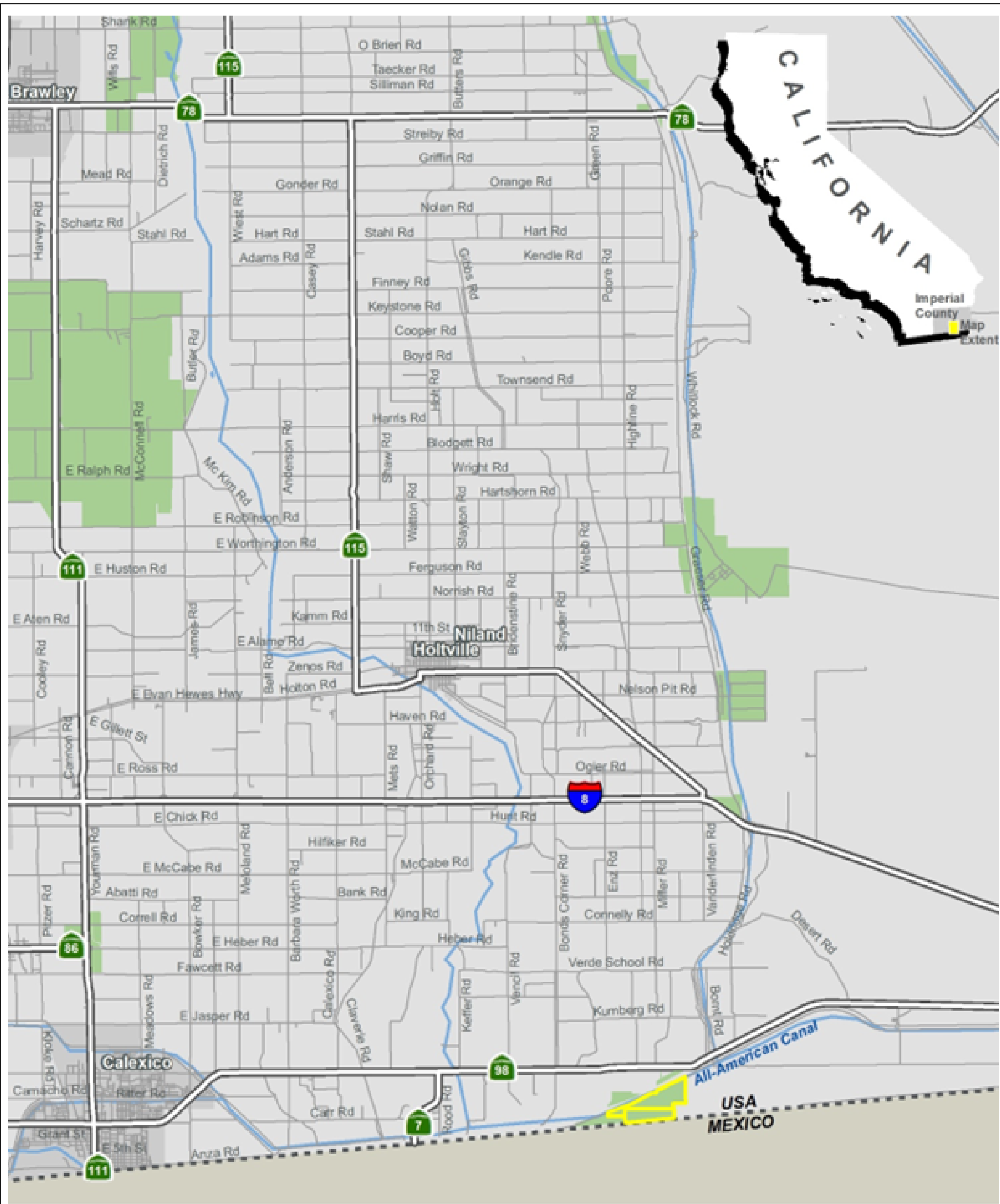
delivered to the existing IID approved point of interconnection (POI) on the 92 kV "P" Line located immediately north of the Project Site and the All-American Canal. Once fully constructed, the Project Site would be developed with a ground mounted PV solar power generating system, supporting structures, on-site substation spanning two acres, BESS, interconnection facilities, and internal access roads. The Project would employ the use of PV power systems to convert solar energy into electricity using non-reflective technology.

Construction activities would primarily involve demolition and grubbing, grading of the Project Site to establish access roads and pads for electrical equipment, trenching for underground electrical collection lines, and the installation of solar equipment and security fencing. Construction is estimated to take 12-18 months and would begin in late 2022 or 2023. The number of on-site construction workers for the solar facility is not expected to exceed 150 workers at any time. The number of on-site construction workers for the BESS and substation is not expected to exceed 100 workers at any one time.

All heavy-duty construction vehicles would cross the All-American Canal at Gordon Wells Road located approximately 20 miles east of the Project Site, then travel west along an existing dirt road paralleling the U.S./Mexico Border. Access for heavy construction vehicles to and from the Project Site requires crossing the All-American Canal, via two existing bridges, located along Gordon Wells Road. Gordon Wells Road has an interchange with Interstate 8. The bridges over the canal were constructed in 2009 and are rated as open with no restrictions and have a "Good" condition rating. An estimated two trucks would arrive at the Project Site each day during the first few weeks of construction of the solar facility. Construction workers would utilize an existing driveway off State Route 98 and then park their vehicles in a designated staging/parking area, approximately 3.5 acres in size, north of the All-American Canal. The staging/parking area is proposed to be improved to facilitate access and minimize parking conflicts. Construction workers would then walk across the All-American Canal at an existing crossing east of the Project Site. No vehicles or construction vehicles are allowed to travel across this existing crossing. Designated shuttles would pick up the construction workers at the south end of the crossing, and then travel west for approximately one mile along an existing dirt road to the Project Site. According to the Project Proponent, dust generated during construction would be controlled by watering and, as necessary, the use of other dust suppression methods and materials accepted by the ICAPCD.

Once construction is completed, the facility would be remotely operated, controlled and monitored and with no requirement for daily on-site employees. Security personnel may conduct unscheduled security rounds and would be dispatched to the Project Site in response to a fence breach or other alarm. Up to two to three people would be contracted (part-time) to perform all routine and emergency operational and maintenance activities. Such activities include inspections, equipment servicing, site and landscape clearing, and periodic washing of the PV modules if needed (up to two times per year) to maintain power generation efficiency. The amount of water needed for solar panel washing is estimated at approximately 5 acre-feet per washing, with up to two washings per year, or a total of up to 10 acre-feet per year. Vegetation growing on the solar energy facility site would periodically (approximately every 3 months) be removed manually and/or treated with herbicides. Workers during Project operations would utilize an existing driveway off State Route 98, park their vehicles in a designated staging/parking area north of the All-American Canal, and then walk across the All-American Canal at an existing crossing east of the Project

Site. No vehicles or construction vehicles are allowed to travel across this existing crossing. Designated shuttles would pick up workers at the south end of the crossing, and then travel west for approximately one mile along an existing dirt road to the Project Site.



Legend

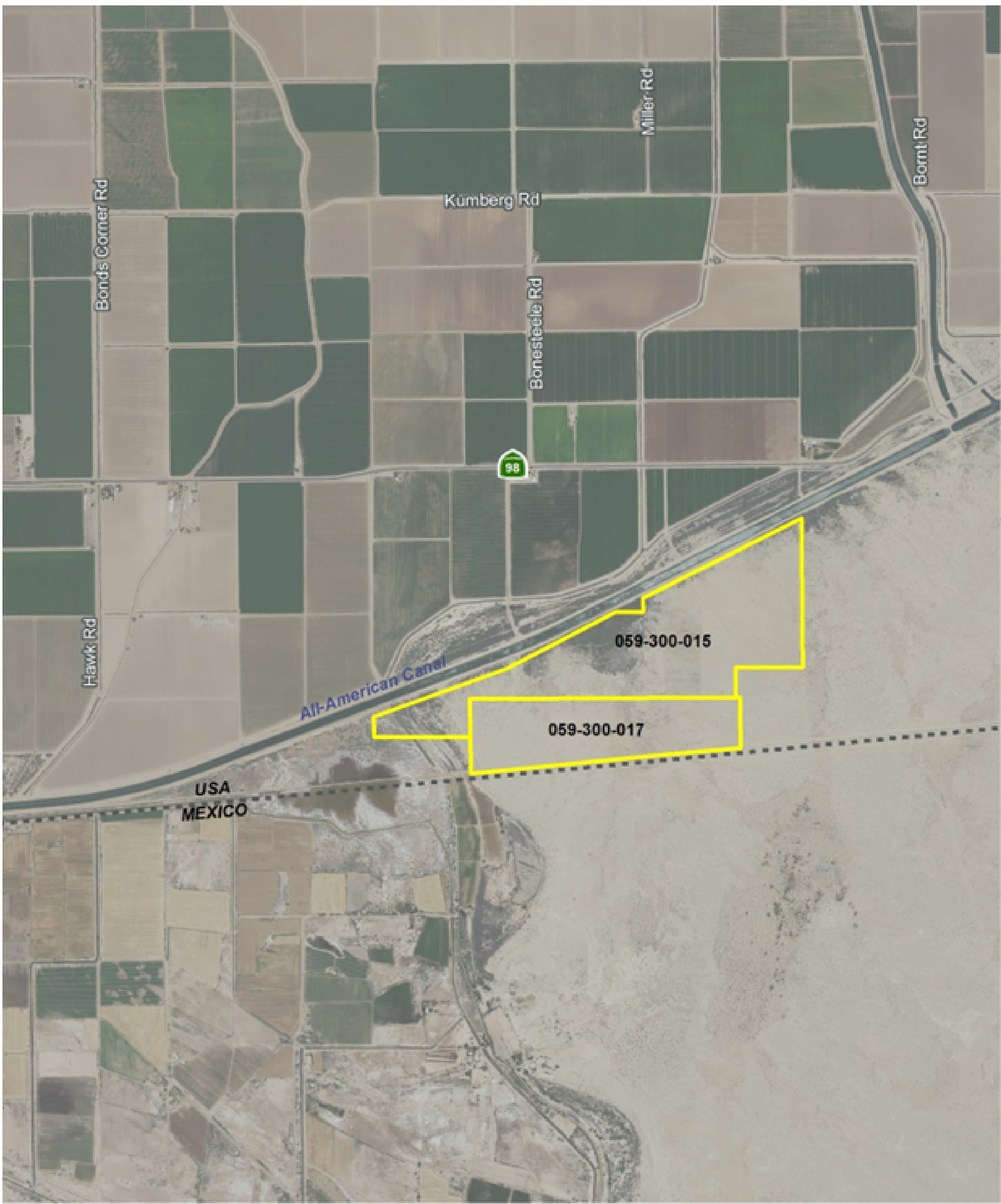
- VEGA SES 4 Project Area
- Renewable Energy Overlay Zone



0 Miles 2

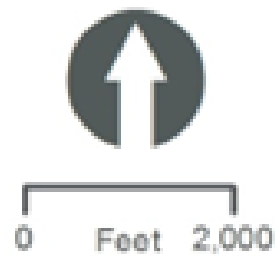
Map Date: 10/26/2022
 Photo (or Base) Source: HDR 2022

Figure 1-1. Regional Location Map
 2020-142 VEGA SES 4 Solar Energy Project



Legend

 VEGA SES 4 Project Parcels



Map Date: 10/26/2022
 Photo (or Base) Source: HDR 2022

Figure 1-2. Project Location Map
 2020-142 VEGA SES 4 Solar Energy Project

2.0 AIR QUALITY

2.1 Air Quality Setting

Air quality in a region is determined by its topography, meteorology, and existing air pollutant sources. These factors are discussed below, along with the current regulatory structure that applies to the Salton Sea Air Basin (SSAB), which encompasses the Project Site, pursuant to the regulatory authority of the ICAPCD.

Ambient air quality is commonly characterized by climate conditions, the meteorological influences on air quality, and the quantity and type of pollutants released. The air basin is subject to a combination of topographical and climatic factors that reduce the potential for high levels of regional and local air pollutants. The following section describes the pertinent characteristics of the air basin and provides an overview of the physical conditions affecting pollutant dispersion in the Project Area.

2.1.1 Salton Sea Air Basin

The California Air Resources Board (CARB) divides the State into air basins that share similar meteorological and topographical features. Imperial County, which extends over 4,482 square miles in the southeastern corner of California, lies in the SSAB, which includes the Imperial Valley and the central part of Riverside County, including the Coachella Valley. The province is characterized by the large-scale sinking and warming of air within the semi-permanent subtropical high-pressure center over the Pacific Ocean. The elevation in Imperial County ranges from about 230 feet below sea level in the Salton Sea to more than 2,800 feet on the mountain summits to the east.

2.1.1.1 Temperature and Precipitation

The flat terrain near the Salton Sea, intense heat from the sun during the day, and strong radiational cooling at night create deep convective thermals during the daytime and equally strong surface-based temperature inversions at night. The temperature inversions and light nighttime winds trap any local air pollution emissions near the ground. The area is subject to frequent hazy conditions at sunrise, followed by rapid daytime dissipation as winds pick up and the temperature warms. The lack of clouds and atmospheric moisture creates strong diurnal and seasonal temperature variations ranging from an average summer maximum of 108 degrees Fahrenheit (° F) down to a winter morning minimum of 38° F. The most pleasant weather occurs from about mid-October to early May when daily highs are in the 70s and 80s with very infrequent cloudiness or rainfall. Imperial County experiences rainfall on an average of only four times per year (>0.10 inches in 24 hours). The local area usually has three days of rain in winter and one thunderstorm day in August. The annual rainfall in this region is less than three inches per year (ICAPCD 2010).

2.1.1.2 Wind

Winds in the area are driven by a complex pattern of local, regional and global forces, but primarily reflect the temperature difference between the cool ocean to the west and the heated interior of the entire desert southwest. For much of the year, winds flow predominantly from the west to the east. In summer, intense solar heating in the Imperial Valley creates a more localized wind pattern, as air comes up from the southeast

via the Gulf of California. During periods of strong solar heating and intense convection, turbulent motion creates good mixing and low levels of air pollution. However, even strong turbulent mixing is insufficient to overcome the limited air pollution controls on sources in the Mexicali, Mexico area. Imperial County is predominately agricultural land. This is a factor in the cumulative air quality of the SSAB. The agricultural production generates dust and small particulate matter through the use of agricultural equipment on unpaved roads, land preparation, and harvest practices. The Imperial County experiences unhealthy air quality from photochemical smog and from dust due to extensive surface disturbance and the very arid climate (ICAPCD 2010).

2.1.1.3 Inversion

The entire county is affected by inversion layers, where warm air overlays cooler air. Inversion layers trap pollutants close to the ground. In the winter, these pollutant-trapping, ground-based inversions are formed during windless, clear-sky conditions, as cold air collects in low-lying areas such as valleys and canyons. Imperial County experiences surface inversions almost every day of the year. Due to strong surface heating, these inversions are usually broken allowing pollutants to be more easily dispersed (ICAPCD 2010).

2.1.2 Criteria Air Pollutants

Criteria air pollutants are defined as those pollutants for which the federal and state governments have established air quality standards for outdoor or ambient concentrations to protect public health with a determined margin of safety. Ozone (O₃), coarse particulate matter (PM₁₀), and fine particulate matter (PM_{2.5}) are generally considered to be regional pollutants because they or their precursors affect air quality on a regional scale. Pollutants such as carbon monoxide (CO), nitrogen dioxide (NO₂), and sulfur dioxide (SO₂) are considered to be local pollutants because they tend to accumulate in the air locally. PM is also considered a local pollutant. Health effects commonly associated with criteria pollutants are summarized in Table 2-1.

Table 2-1. Criteria Air Pollutants- Summary of Common Sources and Effects		
Pollutant	Major Manmade Sources	Human Health & Welfare Effects
CO	An odorless, colorless gas formed when carbon in fuel is not burned completely; a component of motor vehicle exhaust.	Reduces the ability of blood to deliver oxygen to vital tissues, effecting the cardiovascular and nervous system. Impairs vision, causes dizziness, and can lead to unconsciousness or death.
NO ₂	A reddish-brown gas formed during fuel combustion for motor vehicles, energy utilities and industrial sources.	Respiratory irritant; aggravates lung and heart problems. Precursor to ozone and acid rain. Causes brown discoloration of the atmosphere.
O ₃	Formed by a chemical reaction between reactive organic gases (ROGs) and nitrous oxides (N ₂ O) in the presence of sunlight. Common sources of these precursor pollutants include motor vehicle exhaust, industrial emissions, solvents, paints and landfills.	Irritates and causes inflammation of the mucous membranes and lung airways; causes wheezing, coughing and pain when inhaling deeply; decreases lung capacity; aggravates lung and heart problems. Damages plants; reduces crop yield.
PM ₁₀ & PM _{2.5}	Power plants, steel mills, chemical plants, unpaved roads and parking lots, wood-burning stoves and fireplaces, automobiles and others.	Increased respiratory symptoms, such as irritation of the airways, coughing, or difficulty breathing; aggravated asthma; development of chronic bronchitis; irregular heartbeat; nonfatal heart attacks; and premature death in people with heart or lung disease. Impairs visibility (haze).
SO ₂	A colorless, nonflammable gas formed when fuel containing sulfur is burned. Examples are refineries, cement manufacturing, and locomotives.	Respiratory irritant. Aggravates lung and heart problems. Can damage crops and natural vegetation. Impairs visibility.

Source: California Air Pollution Control Officers Association (CAPCOA 2013)

2.1.2.1 Carbon Monoxide

CO in the urban environment is associated primarily with the incomplete combustion of fossil fuels in motor vehicles. CO combines with hemoglobin in the bloodstream and reduces the amount of oxygen that can be circulated through the body. High CO concentrations can cause headaches, aggravate cardiovascular disease and impair central nervous system functions. CO concentrations can vary greatly over comparatively short distances. Relatively high concentrations of CO are typically found near crowded intersections and along heavy roadways with slow moving traffic. Even under the most severe meteorological and traffic conditions, high concentrations of CO are limited to locations within relatively short distances of the source. Overall CO emissions are decreasing as a result of the Federal Motor Vehicle Control Program, which has mandated increasingly lower emission levels for vehicles manufactured since 1973. CO levels in the SSAB are in compliance with the state and federal one- and eight-hour standards.

2.1.2.2 Nitrogen Oxides

Nitrogen gas comprises about 80 percent of the air and is naturally occurring. At high temperatures and under certain conditions, nitrogen can combine with oxygen to form several different gaseous compounds

collectively called nitric oxides (NO_x). Motor vehicle emissions are the main source of NO_x in urban areas. NO_x is very toxic to animals and humans because of its ability to form nitric acid with water in the eyes, lungs, mucus membrane, and skin. In animals, long-term exposure to NO_x increases susceptibility to respiratory infections, and lowering resistance to such diseases as pneumonia and influenza. Laboratory studies show that susceptible humans, such as asthmatics, who are exposed to high concentrations can suffer from lung irritation or possible lung damage. Precursors of NO_x, such as NO and NO₂, attribute to the formation of O₃ and PM_{2.5}. Epidemiological studies have also shown associations between NO₂ concentrations and daily mortality from respiratory and cardiovascular causes and with hospital admissions for respiratory conditions.

2.1.2.3 Ozone

O₃ is a secondary pollutant, meaning it is not directly emitted. It is formed when volatile organic compounds (VOCs) or ROGs and NO_x undergo photochemical reactions that occur only in the presence of sunlight. The primary source of ROG emissions is unburned hydrocarbons in motor vehicle and other internal combustion engine exhaust. NO_x forms as a result of the combustion process, most notably due to the operation of motor vehicles. Sunlight and hot weather cause ground-level O₃ to form. Ground-level O₃ is the primary constituent of smog. Because O₃ formation occurs over extended periods of time, both O₃ and its precursors are transported by wind and high O₃ concentrations can occur in areas well away from sources of its constituent pollutants.

People with lung disease, children, older adults, and people who are active can be affected when O₃ levels exceed ambient air quality standards. Numerous scientific studies have linked ground-level O₃ exposure to a variety of problems including lung irritation, difficult breathing, permanent lung damage to those with repeated exposure, and respiratory illnesses.

2.1.2.4 Particulate Matter

PM includes both aerosols and solid particulates of a wide range of sizes and composition. Of concern are those particles smaller than or equal to 10 microns in diameter size (PM₁₀) and small than or equal to 2.5 microns in diameter (PM_{2.5}). Smaller particulates are of greater concern because they can penetrate deeper into the lungs than larger particles. PM₁₀ is generally emitted directly as a result of mechanical processes that crush or grind larger particles or form the resuspension of dust, typically through construction activities and vehicular travel. PM₁₀ generally settles out of the atmosphere rapidly and is not readily transported over large distances. PM_{2.5} is directly emitted in combustion exhaust and is formed in atmospheric reactions between various gaseous pollutants, including NO_x, sulfur oxides (SO_x) and VOCs. PM_{2.5} can remain suspended in the atmosphere for days and/or weeks and can be transported long distances.

The principal health effects of airborne PM are on the respiratory system. Short-term exposure of high PM_{2.5} and PM₁₀ levels are associated with premature mortality and increased hospital admissions and emergency room visits. Long-term exposure is associated with premature mortality and chronic respiratory disease. According to the U.S. Environmental Protection Agency (USEPA), some people are much more sensitive than others to breathing PM₁₀ and PM_{2.5}. People with influenza, chronic respiratory and cardiovascular diseases, and the elderly may suffer worse illnesses; people with bronchitis can expect aggravated symptoms; and

children may experience decline in lung function due to breathing in PM₁₀ and PM_{2.5}. Other groups considered sensitive include smokers and people who cannot breathe well through their noses. Exercising athletes are also considered sensitive because many breathe through their mouths.

2.1.3 Toxic Air Contaminants

In addition to the criteria pollutants discussed above, toxic air contaminants (TACs) are another group of pollutants of concern. TACs are considered either carcinogenic or noncarcinogenic based on the nature of the health effects associated with exposure to the pollutant. For regulatory purposes, carcinogenic TACs are assumed to have no safe threshold below which health impacts would not occur, and cancer risk is expressed as excess cancer cases per one million exposed individuals. Noncarcinogenic TACs differ in that there is generally assumed to be a safe level of exposure below which no negative health impact is believed to occur. These levels are determined on a pollutant-by-pollutant basis.

There are many different types of TACs, with varying degrees of toxicity. Sources of TACs include industrial processes such as petroleum refining and chrome plating operations, commercial operations such as gasoline stations and dry cleaners, and motor vehicle exhaust. Additionally, diesel engines emit a complex mixture of air pollutants composed of gaseous and solid material. The solid emissions in diesel exhaust are known as diesel particulate matter (DPM). In 1998, California identified DPM as a TAC based on its potential to cause cancer, premature death, and other health problems (e.g., asthma attacks and other respiratory symptoms). Those most vulnerable are children (whose lungs are still developing) and the elderly (who may have other serious health problems). Overall, diesel engine emissions are responsible for the majority of California's known cancer risk from outdoor air pollutants. Public exposure to TACs can result from emissions from normal operations, as well as from accidental releases of hazardous materials during upset conditions. The health effects of TACs include cancer, birth defects, neurological damage, and death.

2.1.3.1 Diesel Exhaust

Most recently, CARB identified DPM as a TAC. DPM differs from other TACs in that it is not a single substance but rather a complex mixture of hundreds of substances. Diesel exhaust is a complex mixture of particles and gases produced when an engine burns diesel fuel. DPM is a concern because it causes lung cancer; many compounds found in diesel exhaust are carcinogenic. DPM includes the particle-phase constituents in diesel exhaust. The chemical composition and particle sizes of DPM vary between different engine types (heavy-duty, light-duty), engine operating conditions (idle, accelerate, decelerate), fuel formulations (high/low sulfur fuel), and the year of the engine (USEPA 2002). Some short-term (acute) effects of diesel exhaust include eye, nose, throat, and lung irritation, and diesel exhaust can cause coughs, headaches, light-headedness, and nausea. DPM poses the greatest health risk among the TACs; due to their extremely small size, these particles can be inhaled and eventually trapped in the bronchial and alveolar regions of the lung.

2.1.4 Ambient Air Quality

Ambient air quality at the Project Site can be inferred from ambient air quality measurements conducted at nearby air quality monitoring stations. CARB maintains more than 60 monitoring stations throughout California. O₃, PM₁₀ and PM_{2.5} are the pollutant species most potently affecting the Project region. As

described in detail below, the Project region is designated as a nonattainment area for the federal O₃ and PM_{2.5} standards and is also a nonattainment area for the state standards for O₃ and PM₁₀ (CARB 2019). The Niland-English Road air quality monitoring station (7711 English Road, Niland), located approximately 23.0 miles northwest of the Project Site, monitors ambient concentrations of O₃ and PM₁₀. The Brawley-Main Street #2 air quality monitoring station (220 Main Street, Brawley), located 15.0 miles west of the Project Site, monitors ambient concentrations of PM_{2.5}. Ambient emission concentrations will vary due to localized variations in emission sources and climate and should be considered “generally” representative of ambient concentrations in the Project Area.

Table 2-2 summarizes the published data concerning O₃, PM_{2.5} and PM₁₀ from the Niland-English Road and Brawley-Main Street #2 monitoring stations for each year that the monitoring data is provided. O₃, PM₁₀ and PM_{2.5} are the pollutant species most potently affecting the Project region.

Table 2-2. Summary of Ambient Air Quality Data			
Pollutant Standards	2018	2019	2020
O₃- Niland-English Road			
Max 1-hour concentration (ppm)	0.060	0.060	0.054
Max 8-hour concentration (ppm) (state/federal)	0.055 / 0.055	0.055 / 0.054	0.046 / 0.045
Number of days above 1-hour standard (state/federal)	0 / 0	0 / 0	0 / 0
Number of days above 8-hour standard (state/federal)	0 / 0	0 / 0	0 / 0
PM₁₀- Niland-English Road			
Max 24-hour concentration (µg/m ³) (state/federal)	333.8 / 331.5	156.3 / 155.7	241.3 / 239.8
Number of days above 24-hour standard (state/federal)	* / 10.1	49.3 / 1.0	68.9 / 1.0
PM_{2.5}- Brawley-Main Street			
Max 24-hour concentration (µg/m ³) (state/federal)	55.1 / 55.1	28.9 / 28.9	23.7 / 23.7
Number of days above federal 24-hour standard	6.1	0	0

Source: CARB 2021a

µg/m³ = micrograms per cubic meter; ppm = parts per million

* = Insufficient data available

The USEPA and CARB designate air basins or portions of air basins and counties as being in “attainment” or “nonattainment” for each of the criteria pollutants. Areas that do not meet the standards are classified as nonattainment areas. The National Ambient Air Quality Standards (NAAQS) (other than O₃, PM₁₀ and PM_{2.5} and those based on annual averages or arithmetic mean) are not to be exceeded more than once per year. The NAAQS for O₃, PM₁₀, and PM_{2.5} are based on statistical calculations over one- to three-year periods, depending on the pollutant. The California Ambient Air Quality Standards (CAAQS) are not to be exceeded during a three-year period. The attainment status for the portion of the SSAB encompassing the Project Site is included in Table 2-3.

Table 2-3. Attainment Status of Criteria Pollutants in the Imperial County Portion of the SSAB

Pollutant	State Designation	Federal Designation
O ₃	Nonattainment	Nonattainment
PM ₁₀	Nonattainment	Attainment
PM _{2.5}	Attainment	Nonattainment
CO	Attainment	Unclassified/Attainment
NO ₂	Attainment	Unclassified/Attainment
SO ₂	Attainment	Unclassified/Attainment

Source: CARB 2019

The determination of whether an area meets the state and federal standards is based on air quality monitoring data. Some areas are unclassified, which means there is insufficient monitoring data for determining attainment or nonattainment. Unclassified areas are typically treated as being in attainment. Because the attainment/nonattainment designation is pollutant-specific, an area may be classified as nonattainment for one pollutant and attainment for another. Similarly, because the state and federal standards differ, an area could be classified as attainment for the federal standards of a pollutant and as nonattainment for the state standards of the same pollutant. The region is designated as a nonattainment area for the federal O₃ and PM_{2.5} standards and is also a nonattainment area for the state standards for O₃ and PM₁₀ (CARB 2019).

2.1.5 Sensitive Receptors

Sensitive receptors are defined as facilities or land uses that include members of the population who are particularly sensitive to the effects of air pollutants, such as children, the elderly, and people with illnesses. Examples of these sensitive receptors are residences, schools, hospitals, and daycare centers. CARB has identified the following groups of individuals as the most likely to be affected by air pollution: the elderly over 65, children under 14, athletes, and persons with cardiovascular and chronic respiratory diseases such as asthma, emphysema, and bronchitis. The nearest existing sensitive receptor to the Project Site is a single-family residence located approximately 0.5 miles from the northeastern corner of the Project boundary.

2.2 Regulatory Framework

2.2.1 Federal

2.2.1.1 Clean Air Act

The Clean Air Act (CAA) of 1970 and the CAA Amendments of 1971 required the USEPA to establish the NAAQS, with states retaining the option to adopt more stringent standards or to include other specific pollutants. On April 2, 2007, the Supreme Court found that carbon dioxide (CO₂) is an air pollutant covered by the CAA; however, no NAAQS have been established for CO₂.

These standards are the levels of air quality considered safe, with an adequate margin of safety, to protect the public health and welfare. They are designed to protect those “sensitive receptors” most susceptible to further respiratory distress such as asthmatics, the elderly, very young children, people already weakened by other disease or illness, and persons engaged in strenuous work or exercise. Healthy adults can tolerate occasional exposure to air pollutant concentrations considerably above these minimum standards before adverse effects are observed.

The USEPA has classified air basins (or portions thereof) as being in attainment, nonattainment, or unclassified for each criteria air pollutant, based on whether or not the NAAQS have been achieved. If an area is designated unclassified, it is because inadequate air quality data were available as a basis for a nonattainment or attainment designation. Table 2-3 lists the federal attainment status of the SSAB for the criteria pollutants.

2.2.2 State

2.2.2.1 California Clean Air Act

The California Clean Air Act (CCAA) allows the state to adopt ambient air quality standards and other regulations provided that they are at least as stringent as federal standards. CARB, a part of the California Environmental Protection Agency, is responsible for the coordination and administration of both federal and state air pollution control programs within California, including setting the CAAQS. CARB also conducts research, compiles emission inventories, develops suggested control measures, and provides oversight of local programs. CARB establishes emissions standards for motor vehicles sold in California, consumer products (such as hairspray, aerosol paints, and barbecue lighter fluid), and various types of commercial equipment. It also sets fuel specifications to further reduce vehicular emissions. CARB also has primary responsibility for the development of California’s State Implementation Plan (SIP), for which it works closely with the federal government and the local air districts.

2.2.2.2 California State Implementation Plan

The CCAA (and its subsequent amendments) requires the state to prepare an air quality control plan referred to as the SIP. The SIP is a living document that is periodically modified to reflect the latest emissions inventories, plans, and rules and regulations of air basins as reported by the agencies with jurisdiction over them. The CAA Amendments dictate that states containing areas violating the NAAQS revise their SIPs to include extra control measures to reduce air pollution. The SIP includes strategies and control measures to attain the NAAQS by deadlines established by the CAA. The USEPA has the responsibility to review all SIPs to determine if they conform to the requirements of the CAA. State law makes CARB the lead agency for all purposes related to the SIP. Local air districts and other agencies prepare SIP elements and submit them to CARB for review and approval. CARB then forwards SIP revisions to the USEPA for approval and publication in the Federal Register.

Local air districts, such as the ICAPCD, prepare air quality attainment plans or air quality management plans and submit them to CARB for review, approval, and incorporation into the applicable SIP. The air districts develop the strategies stated in the SIPs for achieving air quality standards on a regional basis.

For 8-Hour O₃, the ICAPCD adopted the 2017 8-hour Ozone State Implementation Plan in October 2018. The plan includes control measures which are an integral part of how the ICAPCD currently controls the ROG and NO_x emissions within the O₃ nonattainment areas. The overall strategy includes programs and control measures which represent the implementation of Reasonable Available Control Technology (40 CFR 51.912) and the assurance that stationary sources maintain a net decrease in emissions.

For PM₁₀, the ICAPCD adopted the PM₁₀ State Implementation Plan in 2018, which maintained previously adopted fugitive dust control measures (Regulation VIII). The USEPA had previously approved Regulation VIII fugitive dust rules into the Imperial County portion of the California SIP in 2013.

For PM_{2.5}, the ICAPCD adopted the PM_{2.5} SIP in April 2018. This SIP concluded that the majority of the PM_{2.5} emissions resulted from transport in nearby Mexico. Specifically, the SIP demonstrates attainment of the 2006 PM_{2.5} NAAQS “but for” transport of international emissions from Mexicali, Mexico. In accordance with the CCAA, the PM_{2.5} SIP satisfies the attainment demonstration requirement satisfying the provisions of the CCAA.

The ICAPCD is working cooperatively with counterparts from Mexico to implement emissions reductions strategies and projects for air quality improvements at the border. The two countries strive to achieve these goals through local input from states, County governments, and citizens. Within the Mexicali and Imperial Valley area, the Air Quality Task Force (AQTF) has been organized to address those issues unique to the border region known as the Mexicali/Imperial air shed. The AQTF membership includes representatives from Federal, State, and local governments from both sides of the border, as well as representatives from academia, environmental organizations, and the general public. This group was created to promote regional efforts to improve the air quality monitoring network, emissions inventories, and air pollution transport modeling development, as well as the creation of programs and strategies to improve air quality.

2.2.2.3 *Tanner Air Toxics Act & Air Toxics “Hot Spots” Information and Assessment Act*

CARB’s Statewide comprehensive air toxics program was established in 1983 with Assembly Bill (AB) 1807, the Toxic Air Contaminant Identification and Control Act (Tanner Air Toxics Act of 1983). AB 1807 created California’s program to reduce exposure to air toxics and sets forth a formal procedure for CARB to designate substances as TACs. Once a TAC is identified, CARB adopts an airborne toxics control measure (ATCM) for sources that emit designated TACs. If there is a safe threshold for a substance at which there is no toxic effect, the control measure must reduce exposure to below that threshold. If there is no safe threshold, the measure must incorporate toxics best available control technology to minimize emissions.

CARB also administers the state’s mobile source emissions control program and oversees air quality programs established by state statute, such as AB 2588, the Air Toxics “Hot Spots” Information and Assessment Act of 1987. Under AB 2588, TAC emissions from individual facilities are quantified and prioritized by the air quality management district or air pollution control district. High priority facilities are required to perform a health risk assessment (HRA) and, if specific thresholds are exceeded, required to communicate the results to the public in the form of notices and public meetings. In September 1992, the “Hot Spots” Act was amended by Senate Bill (SB) 1731, which required facilities that pose a significant health risk to the community to reduce their risk through a risk management plan.

2.2.3 Local

2.2.3.1 Imperial County Air Pollution Control District

The ICAPCD is the local air quality agency and shares responsibility with CARB for ensuring that state and federal ambient air quality standards are achieved and maintained in the SSAB. Furthermore, ICAPCD adopts and enforces controls on stationary sources of air pollutants through its permit and inspection programs and regulates agricultural burning. Other ICAPCD responsibilities include monitoring ambient air quality, preparing clean air plans, planning activities such as modeling and maintenance of the emission inventory, and responding to citizen air quality complaints.

To achieve and maintain ambient air quality standards, the ICAPCD has adopted various rules and regulations for the control of airborne pollutants. The ICAPCD Rules and Regulations that are applicable to the Proposed Project include, but are not limited to, ICAPCD Regulation VIII (Fugitive Dust Rules). The purpose of this regulation is to reduce the amount of PM₁₀ entrained in the ambient air as a result of emissions generated from construction and other earthmoving activities by requiring actions to prevent, reduce, or mitigate PM₁₀ emissions. Regulation VIII requires the Project to adopt best available control measures to minimize emissions from surface-disturbing activities. These measures include the following (ICAPCD 2017):

- All disturbed areas, including bulk material storage which is not being actively utilized, shall be effectively stabilized and visible emissions shall be limited to no greater than 20 percent opacity for dust emissions by using water, chemical stabilizers, dust suppressants, tarps, or other suitable material such as vegetative ground cover.
- All on-site and off-site unpaved roads will be effectively stabilized, and visible emissions shall be limited to no greater than 20 percent opacity for dust emissions by paving, chemical stabilizers, or dust suppressants.
- All unpaved traffic areas of 1 acre or more with 75 or more average vehicle trips per day will be effectively stabilized and visible emissions shall be limited to no greater than 20 percent opacity for dust emissions by paving, chemical stabilizers, dust suppressants, and/or watering.
- The transport of bulk materials shall be completely covered unless 6 inches of freeboard space from the top of the container is maintained with no spillage and loss of bulk material. In addition, the cargo compartment of all haul trucks is to be cleaned and/or washed at the delivery site after removal of bulk material.
- All track-out or carry-out will be cleaned at the end of each workday or immediately when mud or dirt extends a cumulative distance of 50 linear feet or more onto a paved road within an urban area.
- Bulk material handling or transfer shall be stabilized prior to handling or at points of transfer with application of sufficient water, chemical stabilizers, or by sheltering or enclosing the operation and transfer line.

- The construction of any new unpaved road is prohibited within any area with a population of 500 or more unless the road meets the definition of a temporary unpaved road. Any temporary unpaved road shall be effectively stabilized and visible emissions shall be limited to no greater than 20 percent opacity for dust emission by paving, chemical stabilizers, dust suppressants and/or watering.

In addition, there are other ICAPCD rules and regulations, not detailed here, which may apply to the Proposed Project, but are administrative or descriptive in nature. These include rules associated with fees, enforcement and penalty actions, and variance procedures.

2.3 Air Quality Emissions Impact Assessment

2.3.1 Thresholds of Significance

The impact analysis provided below is based on the following California Environmental Quality Act (CEQA) Guidelines Appendix G thresholds of significance. The Project would result in a significant impact to air quality if it would do any of the following:

1. Conflict with or obstruct implementation of any applicable air quality plan.
2. Result in a cumulatively considerable net increase of any criteria pollutant for which the Project region is nonattainment under an applicable federal or state ambient air quality standard (including releasing emissions which exceed quantitative thresholds for ozone precursors).
3. Expose sensitive receptors to substantial pollutant concentrations.
4. Result in other emissions (such as those leading to odors adversely affecting a substantial number of people).

2.3.1.1 Imperial County Air Pollution Control District Thresholds

The significance criteria established by the applicable air quality management or air pollution control district (ICAPCD) may be relied upon to make the above determinations. The ICAPCD has identified significance thresholds for use in evaluating project impacts under CEQA. Accordingly, the ICAPCD-recommended thresholds of significance are used to determine whether implementation of the proposed Project would result in a significant air quality impact. Significance thresholds for evaluation construction and operational air quality impacts are listed in Table 2-4.

Table 2-4. ICAPCD Significance Thresholds – Pounds per Day			
Criteria Pollutant and Precursors	Construction Activities	Operations	
	Average Daily Emissions (lbs/day)	Average Daily Emissions (lbs/day)	
		Tier I Threshold	Tier II Threshold
ROG	75	<137	> 137
NO _x	100	<137	> 137
PM ₁₀	150	<150	> 150
PM _{2.5}	N/A	<550	> 550
CO	550	<550	> 550
SO ₂	N/A	<150	> 150

Source: ICAPCD 2017

Projects that are predicted to exceed Tier I thresholds require implementation of applicable ICAPCD standard mitigation measures to be considered less than significant. Projects exceeding Tier II thresholds are required to implement applicable ICAPCD standard mitigation measures, as well as applicable discretionary mitigation measures. Projects that exceed the Tier II thresholds after implementation of standard and discretionary mitigation measures would be considered to have a potentially significant impact to human health and welfare.

By its very nature, air pollution is largely a cumulative impact. No single project is sufficient in size, by itself, to result in nonattainment of ambient air quality standards. Instead, a project's individual emissions contribute to existing cumulatively significant adverse air quality impacts. If a project's individual emissions exceed its identified significance thresholds, the project would be cumulatively considerable. Projects that do not exceed significance thresholds would not be considered cumulative considerable.

2.3.2 Methodology

Air quality impacts were assessed in accordance with methodologies recommended by the ICAPCD. Where criteria air pollutant quantification was required, emissions were modeled using the California Emissions Estimator Model (CalEEMod), version 2020.4.0. CalEEMod is a statewide land use emissions computer model designed to quantify potential criteria pollutant emissions associated with both construction and operations from a variety of land use projects. Project construction-generated air pollutant emissions were calculated using CalEEMod model defaults for Imperial County coupled with information provided by the Project applicant. For instance, as described in the Section 1.2, *Project Overview*, construction activities would primarily involve demolition and grubbing, grading of the Project Site to establish access roads and pads for electrical equipment, trenching for underground electrical collection lines, and the installation of solar equipment and security fencing. Construction is estimated to take 12-18 months and would begin in late 2022 or 2023. The number of on-site construction workers for the solar facility is not expected to exceed 150 workers at any time. The number of on-site construction workers for the BESS and substation is not expected to exceed 100 workers at any one time. According to the Traffic Study prepared for the Project

(KOA 2020), Project construction would generate a maximum of 500 construction worker-commute trips in a single day.

Construction workers would utilize an existing driveway off State Route 98 and then park their vehicles in a designated staging/parking area, approximately 3.5 acres in size, north of the All-American Canal. The staging/parking area is proposed to be improved to facilitate access and minimize parking conflicts. Construction workers would then walk across the All-American Canal at an existing crossing east of the Project Site. No vehicles or construction vehicles are allowed to travel across this existing crossing. Designated shuttles would pick up the construction workers at the south end of the crossing, and then travel west for approximately one mile along an existing dirt road to the Project Site. The Traffic Impact Study prepared for the Project (KOA 2020) identifies the site trip distribution of construction worker commute traffic. It is noted that all of the roadways identified as construction worker commute routes are paved (KOA 2020). Thus, the PM emissions associated with construction workers traversing 1.15 miles of unpaved roads are accounted (0.15 mile of roadway at staging/parking area and 1.0 mile of dirt road south of the All-American Canal).

All heavy-duty construction vehicles would cross the All-American Canal at Gordon Wells Road located approximately 20 miles east of the Project Site. An estimated two trucks hauling construction equipment and Project materials would arrive at the Project Site each day during the first few weeks of construction via Gordon Wells Road and the 20 miles of existing dirt road paralleling the U.S./Mexico Border. The PM emissions associated with two haul trucks traversing this existing dirt road to and from the site daily are accounted for.

Operational air pollutant emissions account for the maximum three workers visiting the site in a single day. Such visits include inspections, equipment servicing, site and landscape clearing, and periodic washing of the PV modules if needed (up to two times per year) to maintain power generation efficiency. Therefore, operational onsite equipment use is accounted in addition to the consumption of 10 acre-feet (3,259,000 gallons) of water annually.

2.3.3 Impact Analysis

2.3.3.1 Project Construction-Generated Criteria Air Quality Emissions

Emissions associated with Project implementation would be temporary and short-term but have the potential to represent a significant air quality impact. Two basic sources of short-term emissions will be generated through Project implementation: operation of the heavy-duty equipment (i.e., excavators, loaders, haul trucks) and the creation of fugitive dust during clearing and grading. Construction activities such as excavation and grading operations, construction vehicle traffic, and wind blowing over exposed soils would generate exhaust emissions and fugitive PM emissions that affect local air quality at various times during construction. Effects would be variable depending on the weather, soil conditions, the amount of activity taking place, and the nature of dust control efforts. The dry climate of the area during the summer months creates a high potential for dust generation. Construction activities would be subject to ICAPCD Regulation VIII which, as previously described, requires taking reasonable precautions to reduce the amount of PM₁₀ entrained in the ambient air as a result of emissions generated from construction and other

earthmoving activities by requiring actions to prevent, reduce, or mitigate PM₁₀ emissions. Regulation VIII requires the Project to adopt best available control measures to minimize emissions from surface-disturbing activities to comply with ICAPCD Regulation VIII (Fugitive Dust Rules).

Emissions associated with Project off-road equipment, worker commute trips, and ground disturbance were calculated using the CARB-approved CalEEMod computer program, which is designed to model emissions for land use development projects, based on typical construction requirements. See Section 2.3.2, *Methodology*, and Attachment A for more information regarding the construction assumptions, including types of construction equipment used and Project duration used in this analysis.

Predicted maximum daily emissions attributable to Project construction are summarized in Table 2-5. Such emissions are short-term and of temporary duration, lasting only as long as Project construction activities occur, but would be considered a significant air quality impact if the volume of pollutants generated exceeds the ICAPCD thresholds of significance.

Table 2-5. Unmitigated Project Construction-Generated Emissions						
Construction Year	Pollutant (pounds per day)					
	ROG	NO_x	CO	SO₂	PM₁₀	PM_{2.5}
Construction in Calendar Year One	5.66	57.65	53.83	0.10	949.93	96.64
Construction in Calendar Year Two	5.18	30.12	52.46	0.09	949.82	96.54
ICAPCD Significance Threshold	75	100	550	N/A	150	N/A
Exceed ICAPCD Threshold?	No	No	No	No	Yes	No

Source: CalEEMod version 2020.4.0. Refer to Attachment A for Model Data Outputs.

Notes: Pounds per day taken from the season with the highest output.

As shown in Table 2-5, emissions generated during Project construction would exceed the ICAPCD significance threshold for PM₁₀. Project construction PM₁₀ is generated primarily from construction worker commute-traffic and delivery trucks traversing dirt roads. As previously described, all heavy-duty construction vehicles would travel on 20 miles of existing dirt road paralleling the U.S./Mexico Border to reach the Project Site. Commuting construction workers would traverse 1.15 miles of unpaved roads (0.15 mile of roadway at staging/parking area and 1.0 mile of dirt road south of the All-American Canal). Fugitive PM₁₀ emissions would also be generated on the Project construction site with grading operations, heavy-duty equipment moving over bare dirt, and wind blowing over exposed and freshly disturbed soils. Thus, mitigation measure AQ-1 is required to reduce impacts to less than significant levels.

AQ-1: Project Construction Dust Suppression

During construction activities the construction contractor shall employ the following PM₁₀ reducing measures:

1. All unpaved roads associated with construction shall be effectively stabilized of dust emissions using Imperial County Air Pollution Control District-approved chemical stabilizers/suppressant before the commencement of construction, and every 30 days thereafter until the end of all construction activities. Unpaved roads associated with construction include:
 - The driveway entrance off State Route 98,
 - The Project designated 3.5-acre staging/parking area north of the All-American Canal,
 - The 1.0 mile of dirt road south of the All-American Canal,
 - The 20 miles of existing dirt road paralleling the U.S./Mexico Border from Gordon Wells Road to the Project Site.

Monthly application of Imperial County Air Pollution Control District-approved chemical stabilizers/suppressant shall be applied at a rate of 0.1 gallon/ square yard of chemical dust suppressant.

2. Prior to any earthmoving activity, the applicant shall submit a construction dust control plan and obtain Imperial County Air Pollution Control District and Imperial County Planning and Development Services Department (ICPDS) approval.
3. Pursuant to ICAPCD, all construction sites, regardless of size, must comply with the requirements contained within Regulation VIII – Fugitive Dust Control Measures. Whereas these Regulation VIII measures are mandatory and are not considered project environmental mitigation measures, the ICAPCD CEQA Handbook's required additional standard and enhanced mitigation measures listed below shall be implemented prior to and during construction. ICAPCD will verify implementation and compliance with these measures as part of the grading permit review/approval process.

ICAPCD Standard Measures for Fugitive Dust (PM₁₀) Control

- All disturbed areas, including bulk material storage, which is not being actively utilized, shall be effectively stabilized and visible emissions shall be limited to no greater than 20 percent opacity for dust emissions by using water, chemical stabilizers, dust suppressants, tarps, or other suitable material, such as vegetative ground cover.
- All on-site and offsite unpaved roads will be effectively stabilized, and visible emissions shall be limited to no greater than 20 percent opacity for dust emissions by paving, chemical stabilizers, dust suppressants, and/or watering.
- All unpaved traffic areas 1 acre or more with 75 or more average vehicle trips per day will be effectively stabilized and visible emissions shall be limited to no greater than 20 percent opacity for dust emissions by paving, chemical stabilizers, dust suppressants, and/or watering.
- The transport of bulk materials shall be completely covered unless 6 inches of freeboard space from the top of the container is maintained with no spillage and loss of bulk

material. In addition, the cargo compartment of all haul trucks is to be cleaned and/or washed at delivery site after removal of bulk material.

- All track-out or carry-out will be cleaned at the end of each workday or immediately when mud or dirt extends a cumulative distance of 50 linear feet or more onto a paved road within an urban area.
- Movement of bulk material handling or transfer shall be stabilized prior to handling or at points of transfer with application of sufficient water, chemical stabilizers, or by sheltering or enclosing the operation and transfer line.
- The construction of any new unpaved road is prohibited within any area with a population of 500 or more unless the road meets the definition of a temporary unpaved road. Any temporary unpaved road shall be effectively stabilized, and visible emissions shall be limited to no greater than 20 percent opacity for dust emission by paving, chemical stabilizers, dust suppressants, and/or watering.

ICAPCD “Discretionary” Measures for Fugitive Dust (PM₁₀) Control

- Water exposed soil only in those areas where active grading and vehicle movement occurs with adequate frequency to control dust.
- Replace ground cover in disturbed areas as quickly as possible.
- Automatic sprinkler system installed on all soil piles.
- Vehicle speed for all construction vehicles shall not exceed 15 miles per hour on any unpaved surface at the construction site.
- Develop a trip reduction plan to achieve a 1.5 average vehicle ridership for construction employees.
- Implement a shuttle service to and from retail services and food establishments during lunch hours.

Standard Mitigation Measures for Construction Combustion Equipment

- Use of alternative fueled or catalyst equipped diesel construction equipment, including all off-road and portable diesel-powered equipment.
- Minimize idling time either by shutting equipment off when not in use or reducing the time of idling to 5 minutes as a maximum.
- Limit, to the extent feasible, the hours of operation of heavy-duty equipment and/or the amount of equipment in use.
- Replace fossil fueled equipment with electrically driven equivalents (provided they are not run via a portable generator set).

Enhanced Mitigation Measures for Construction Equipment

To help provide a greater degree of reduction of PM emissions from construction combustion equipment, Imperial County Air Pollution Control District recommends the following enhanced measures.

- Curtail construction during periods of high ambient pollutant concentrations; this may include ceasing of construction activity during the peak hour of vehicular traffic on adjacent roadways.
- Implement activity management (e.g., rescheduling activities to reduce short-term impacts).

Table 2-6 shows the results of construction emissions with implementation of Mitigation Measure AQ-1.

Table 2-6. Mitigated Project Construction-Generated Emissions						
Construction Year	Pollutant (pounds per day)					
	ROG	NO_x	CO	SO₂	PM₁₀	PM_{2.5}
Construction in Calendar Year One	5.66	57.61	53.83	0.10	91.86	11.00
Construction in Calendar Year Two	5.18	30.03	52.46	0.09	91.75	10.90
ICAPCD Significance Threshold	75	100	550	N/A	150	N/A
Exceed ICAPCD Threshold?	No	No	No	No	No	No

Source: CalEEMod version 2020.4.0. Refer to Attachment A for Model Data Outputs.

Notes: Pounds per day taken from the season with the highest output. PM reduction values associated with the implementation of soil stabilizers on unpaved roads monthly over the course of construction per email communication with Monica Soucier of the ICAPCD (2021).

As shown in Table 2-6, emissions generated during Project construction would not exceed the ICAPCD's thresholds of significance with implementation of mitigation measure AQ-1. Therefore, criteria pollutant emissions generated during Project construction would not result in a cumulatively considerable net increase of any criteria pollutant for which the Project region is nonattainment under an applicable federal or state ambient air quality standard.

2.3.3.2 Operational Criteria Air Quality Emissions

Although limited, implementation of the Project would result in long-term operational emissions of criteria air pollutants such as PM₁₀, PM_{2.5}, CO, and SO₂ as well as O₃ precursors such as ROG and NO_x. Project-generated increases in emissions would be predominately associated with motor vehicle use for routine maintenance work and site security. Long-term operational emissions attributable to the Project are identified in Table 2-7 and compared to the operational significance thresholds promulgated by the ICAPCD.

Table 2-7. Operational-Related Emissions (Regional Significance Analysis)						
Emission Source	Pollutant (pounds per day)					
	ROG	NO_x	CO	SO₂	PM₁₀	PM_{2.5}
Summer Emissions						
Area	13.59	0.00	0.06	0.00	0.00	0.00
Energy	0.26	2.42	2.03	0.01	0.18	0.18
Mobile	0.02	0.03	0.31	0.00	4.84	0.49
Offroad Equipment	1.16	11.09	12.70	0.02	0.56	0.51
Total:	15.04	13.55	15.11	0.03	5.59	1.19
<i>ICAPCD Significance Threshold</i>	<i>137</i>	<i>137</i>	<i>150</i>	<i>550</i>	<i>550</i>	<i>150</i>
Exceed ICAPCD Significance Threshold?	No	No	No	No	No	No
Winter Emissions						
Area	13.59	0.00	0.06	0.00	0.00	0.00
Energy	0.26	2.42	2.03	0.01	0.18	0.18
Mobile	0.02	0.03	0.24	0.00	4.84	0.49
Offroad Equipment	1.16	11.09	12.70	0.02	0.56	0.51
Total:	15.04	13.55	15.04	0.03	5.59	1.19
<i>ICAPCD Significance Threshold</i>	<i>137</i>	<i>137</i>	<i>150</i>	<i>550</i>	<i>550</i>	<i>150</i>
Exceed ICAPCD Significance Threshold?	No	No	No	No	No	No

Source: CalEEMod version 2020.4.0. Refer to Attachment A for Model Data Outputs.

As shown in Table 2-7, the Project's emissions would not exceed any ICAPCD's thresholds for any criteria air pollutants during operation. Additionally, the purpose of the Project is the operation of a renewable energy and storage facility. Once in operation, it will decrease the need for energy from fossil fuel-based power plants in the state (see Table 2-8). Thus, once operational the Project would represent a beneficial impact to air quality.

2.3.3.3 Conflict with an Applicable Air Quality Management Plan

As previously described, the Project region is classified as nonattainment for federal O₃ and PM_{2.5} standards (CARB 2019). The USEPA, under the provisions of the CAA, requires each state with regions that have not attained the federal air quality standards to prepare a SIP, detailing how these standards are to be met in each local area. The SIP is a legal agreement between each state and the federal government to commit resources to improving air quality. It serves as the template for conducting regional and project-level air

quality analysis. CARB is the lead agency for developing the SIP in California. Local air districts, such as the ICAPCD, prepare air quality attainment plans or air quality management plans and submit them to CARB for review, approval, and incorporation into the applicable SIP. The air districts develop the strategies stated in the SIPs for achieving air quality standards on a regional basis.

The region's SIP is constituted of the ICAPCD air quality plans: 2018 PM₁₀ SIP, the 2018 Annual PM_{2.5} SIP, the 2017 8-Hour Ozone SIP, 2013 24-Hour PM_{2.5} SIP, the 2009 1997 8-hour Ozone RACT SIP, the 2009 PM₁₀ SIP and the 2008 Ozone Early Progress Plans. Project compliance with all of the ICAPCD rules and regulations results in conformance with the ICAPCD air quality plans. These air quality attainment plans are a compilation of new and previously submitted plans, programs (such as monitoring, modeling, permitting, etc.), district rules, state regulations, and federal controls describing how the state will attain ambient air quality standards. These SIP plans and associated control measures are based on information derived from projected growth in Imperial County in order to project future emissions and then determine strategies and regulatory controls for the reduction of emissions. Growth projections are based on the general plans developed by Imperial County and the incorporated cities in the county.

As previously described, the Project consists of the construction of a 100-MW alternating current solar field, consisting of 226,800 tracker modules in 7,560 strings and associated collector and inverter facilities, and a 100 MW BESS, on approximately 585 acres of vacant land. The Project would not result in population growth and would not cause an increase in currently established population projections. The Project does not include residential development or large local or regional employment centers, and thus would not result in significant population or employment growth.

Furthermore, the operation of the Project would create renewable energy over its planned lifetime and decrease the need for energy from fossil fuel-based power plants in the state, which is considered a beneficial impact to statewide air quality. The energy produced by the Project would displace the criteria pollutant emissions which would otherwise be produced by existing business-as-usual power generation resources (including natural gas and coal).

Table 2-8 shows the emissions that would potentially be displaced by the Proposed Project. Note that this estimate only includes that associated with the combustion of fossil fuels; it does not include the vehicle trips associated with the Project's operations, and it similarly does not include operational employee trips associated with natural gas or coal combustion nor the emissions associated with extracting and transporting those power sources. In addition, this estimate only includes the displacement of that portion of the California market that comes from fossil fuels and does not include the approximate 50 percent of the California electricity generated by non-combustion sources (wind, solar, nuclear, hydro-electric) (California Energy Commission [CEC] 2020). Displacement of fossil fuel emissions has a direct beneficial effect on human health for those receptors downwind of the location of the fossil fuel power plants.

Table 2-8. Proposed Project Displaced Criteria Pollutant Emissions (Tons)						
Construction Year	Emissions (Tons)					
	ROG	NO_x	CO	SO₂	PM₁₀	PM_{2.5}
Emissions Displaced Annually (tons)						
Displaced Natural Gas-Source Emissions	0.00	2.14	0.65	1.47	2.03	0.82
Displaced Coal-Source Emissions	0.00	13.97	0.58	0.66	0.10	0.07
Total	0.00	16.11	1.23	2.13	2.13	0.89
Emissions Displaced over 30 Years (tons)						
Total	0	483.37	36.93	64.03	63.93	26.75

Source: Displaced emissions calculated by ECORP using USEPA's AP-42 Fifth Edition Compilation of Air Emissions Factors 1995; 2015. See Attachment B.

Notes: In order to provide a conservative analysis, the proposed Project is assumed to generate electricity 25 percent of the time available (2,190 hours annually). Heat Rate indicates the energy generator efficiency of existing fossil-fuel based energy generators. The heat rate of a power plant measures the amount of fuel used to generate one unit of electricity. Power plants with lower heat rates are more efficient than plants with higher heat rates. The CEC's "Updated Thermal Power Plant Efficiency Measures and Operational Characteristics for Production Cost Modeling" (2019) estimates heat rates and operating ranges for thermal power plants supplying energy to California. The average heat rate of power plants types are as follows:

**Steam Boiler fueled by coal: 10,800 heat rate **Steam Boiler fueled by natural gas: 10,200 heat rate **Gas Turbine: 10,100 heat rate **Combined natural gas Boiler and Turbine: 7,640 heat rate.

By omitting steam boilers fueled by coal since so little of California's energy is derived from coal, the average heat rate = 9,313 [(10,100 + 10,200 + 7,640) ÷ 3 = 9,313]. 100 MW (219,000,000 annual kWh) x 9,313 heat rate = 2,039,547,000,000 Btu displaced from fossil fuel production. Fossil fuel-based energy consumption in California is predominately derived from natural gas (37.06 percent). Coal constitutes 2.74 percent of all fossil fuel-based energy. Therefore, 865,175,837,400 of the displaced Btu is displaced natural gas consumption and 55,883,587,800 of the displaced Btu is displaced coal. The heat content of coal is assumed at 24 million Btu per ton of coal burned. At a rate of 24 million Btu per ton of coal burned, the Project would displace 2,328 tons of burned coal annually.

As shown, the Project would potentially displace approximately 483 tons of NO_x, 37 tons of CO, 64 tons of SO₂, 64 tons of PM₁₀, and 27 tons of PM_{2.5} over the course of 30 years. Furthermore, as demonstrated in Table 2-6 and Table 2-7, the Project would not exceed the applicable significance thresholds for construction or operational-source emissions.

2.3.3.4 Exposure of Sensitive Receptors to Toxic Air Contaminants

As previously described, sensitive receptors are defined as facilities or land uses that include members of the population that are particularly sensitive to the effects of air pollutants, such as children, the elderly, and people with illnesses. Examples of these sensitive receptors are residences, schools, hospitals, and daycare centers. CARB has identified the following groups of individuals as the most likely to be affected by air pollution: the elderly over age 65, children under age 14, athletes, and persons with cardiovascular and chronic respiratory diseases such as asthma, emphysema, and bronchitis. The nearest existing sensitive

land use to the Project Site is a single-family residence located approximately 0.5 miles from the northeastern corner of the Project boundary.

Construction-Generated Air Contaminants

Construction of the Project would result in temporary, short-term proposed Project-generated emissions of diesel particulate matter (DPM), ROG, NO_x, CO, and PM₁₀ from the exhaust of off-road, heavy-duty diesel equipment for Project construction; soil hauling truck traffic; paving; and other miscellaneous activities. The portion of the SSAB which encompasses the Project Area is designated as a nonattainment area for federal O₃ and PM_{2.5} standards and is also a nonattainment area for the state standards for O₃ and PM₁₀ (CARB 2019). Thus, existing O₃ and PM₁₀ levels in the SSAB are at unhealthy levels during certain periods. However, as shown in Table 2-5, the Project would not exceed the ICAPCD significance thresholds for construction emissions.

The health effects associated with O₃ are generally associated with reduced lung function. Because the Project would not involve construction activities that would result in O₃ precursor emissions (ROG or NO_x) in excess of the ICAPCD thresholds, the Project is not anticipated to substantially contribute to regional O₃ concentrations and the associated health impacts.

CO tends to be a localized impact associated with congested intersections. In terms of adverse health effects, CO competes with oxygen, often replacing it in the blood, reducing the blood's ability to transport oxygen to vital organs. The results of excess CO exposure can include dizziness, fatigue, and impairment of central nervous system functions. The Project would not involve activities that would result in CO emissions in excess of the ICAPCD thresholds. Thus, the Project's CO emissions would not contribute to the health effects associated with this pollutant.

Particulate matter (PM₁₀ and PM_{2.5}) contains microscopic solids or liquid droplets that are so small that they can get deep into the lungs and cause serious health problems. Particulate matter exposure has been linked to a variety of problems, including premature death in people with heart or lung disease, nonfatal heart attacks, irregular heartbeat, aggravated asthma, decreased lung function, and increased respiratory symptoms such as irritation of the airways, coughing, or difficulty breathing. For construction-type activity, DPM is the primary TAC of concern. PM₁₀ exhaust is considered a surrogate for DPM as all diesel exhaust is considered to be DPM. Most PM₁₀ exhaust derives from combustion, such as use of gasoline and diesel fuels by motor vehicles. As with O₃ and NO_x, the Project would not generate emissions of PM₁₀ or PM_{2.5} that would exceed the ICAPCD's thresholds. Accordingly, the Project's PM₁₀ and PM_{2.5} emissions are not expected to cause any increase in related regional health effects for these pollutants.

In summary, Project construction would not result in a potentially significant contribution to regional concentrations of nonattainment pollutants and would not result in a significant contribution to the adverse health impacts associated with those pollutants.

Operational Air Contaminants

Operation of the Proposed Project would not result in the development of any substantial sources of air toxics. There would be no stationary sources associated Project operations; nor would the Project attract

additional mobile sources that spend long periods queuing and idling at the site. Onsite Project emissions would not result in significant concentrations of pollutants at the nearby sensitive receptor as the predominant operational emissions associated with the Proposed Project would be routine maintenance work, water deliveries, and site security. Therefore, the Project would not be a substantial source of TACs. The Project will not result in a high carcinogenic or non-carcinogenic risk during operation.

Carbon Monoxide Hot Spots

It has long been recognized that CO exceedances are caused by vehicular emissions, primarily when idling at intersections. Concentrations of CO are a direct function of the number of vehicles, length of delay, and traffic flow conditions. Under certain meteorological conditions, CO concentrations close to congested intersections that experience high levels of traffic and elevated background concentrations may reach unhealthy levels, affecting nearby sensitive receptors. Given the high traffic volume potential, areas of high CO concentrations, or "hot spots," are typically associated with intersections that are projected to operate at unacceptable levels of service during the peak commute hours. It has long been recognized that CO hotspots are caused by vehicular emissions, primarily when idling at congested intersections. However, transport of this criteria pollutant is extremely limited, and CO disperses rapidly with distance from the source under normal meteorological conditions. Furthermore, vehicle emissions standards have become increasingly more stringent in the last 20 years. Currently, the allowable CO emissions standard in California is a maximum of 3.4 grams/mile for passenger cars (there are requirements for certain vehicles that are more stringent). With the turnover of older vehicles, introduction of cleaner fuels, and implementation of increasingly sophisticated and efficient emissions control technologies, CO concentration in the SSAB is designated as an attainment area. Detailed modeling of Project-specific CO "hot spots" is not necessary and thus this potential impact is addressed qualitatively.

A CO "hot spot" would occur if an exceedance of the state one-hour standard of 20 parts per million (ppm) or the eight-hour standard of 9 ppm were to occur. The analysis prepared for CO attainment in the South Coast Air Quality Management District's (SCAQMD's) *1992 Federal Attainment Plan for Carbon Monoxide* in Los Angeles County and a Modeling and Attainment Demonstration prepared by the SCAQMD as part of the 2003 Air Quality Management Plan can be used to demonstrate the potential for CO exceedances of these standards. The SCAQMD is the air pollution control officer for much of southern California. The SCAQMD conducted a CO hot spot analysis as part of the 1992 CO Federal Attainment Plan at four busy intersections in Los Angeles County during the peak morning and afternoon time periods. The intersections evaluated included Long Beach Boulevard and Imperial Highway (Lynwood), Wilshire Boulevard and Veteran Avenue (Westwood), Sunset Boulevard and Highland Avenue (Hollywood), and La Cienega Boulevard and Century Boulevard (Inglewood). The busiest intersection evaluated was at Wilshire Boulevard and Veteran Avenue, which has a traffic volume of approximately 100,000 vehicles per day. Despite this level of traffic, the CO analysis concluded that there was no violation of CO standards (SCAQMD 1992). In order to establish a more accurate record of baseline CO concentrations, a CO "hot spot" analysis was conducted in 2003 at the same four busy intersections in Los Angeles at the peak morning and afternoon time periods. This "hot spot" analysis did not predict any violation of CO standards. The highest one-hour concentration was measured at 4.6 ppm at Wilshire Boulevard and Veteran Avenue and the highest eight-hour concentration

was measured at 8.4 ppm at Long Beach Boulevard and Imperial Highway. Thus, there was no violation of CO standards.

Similar considerations are also employed by other Air Districts when evaluating potential CO concentration impacts. More specifically, the Bay Area Air Quality Management District (BAAQMD), the air pollution control officer for the San Francisco Bay Area, concludes that under existing and future vehicle emission rates, a given project would have to increase traffic volumes at a single intersection by more than 44,000 vehicles per hour or 24,000 vehicles per hour where vertical and/or horizontal air does not mix—in order to generate a significant CO impact.

The Proposed Project is anticipated to result in no more than 6 daily traffic trips. It is noted that this is a conservative estimate, and many days will have no operational related vehicle trips. Thus, the Proposed Project would not generate traffic volumes at any intersection of more than 100,000 vehicles per day (or 44,000 vehicles per day) and there is no likelihood of the Project traffic exceeding CO values.

2.3.3.5 Odors

Typically, odors are regarded as an annoyance rather than a health hazard. However, manifestations of a person's reaction to foul odors can range from psychological (e.g., irritation, anger, or anxiety) to physiological (e.g., circulatory and respiratory effects, nausea, vomiting, and headache).

With respect to odors, the human nose is the sole sensing device. The ability to detect odors varies considerably among the population and overall is quite subjective. Some individuals have the ability to smell minute quantities of specific substances; others may not have the same sensitivity but may have sensitivities to odors of other substances. In addition, people may have different reactions to the same odor; in fact, an odor that is offensive to one person (e.g., from a fast-food restaurant) may be perfectly acceptable to another. It is also important to note that an unfamiliar odor is more easily detected and is more likely to cause complaints than a familiar one. This is because of the phenomenon known as odor fatigue, in which a person can become desensitized to almost any odor and recognition only occurs with an alteration in the intensity.

Quality and intensity are two properties present in any odor. The quality of an odor indicates the nature of the smell experience. For instance, if a person describes an odor as flowery or sweet, then the person is describing the quality of the odor. Intensity refers to the strength of the odor. For example, a person may use the word "strong" to describe the intensity of an odor. Odor intensity depends on the odorant concentration in the air. When an odorous sample is progressively diluted, the odorant concentration decreases. As this occurs, the odor intensity weakens and eventually becomes so low that the detection or recognition of the odor is quite difficult. At some point during dilution, the concentration of the odorant reaches a detection threshold. An odorant concentration below the detection threshold means that the concentration in the air is not detectable by the average human.

During construction, the Proposed Project presents the potential for generation of objectionable odors in the form of diesel exhaust in the immediate vicinity of the site. However, these emissions are short-term in nature and will rapidly dissipate and be diluted by the atmosphere downwind of the emission sources. Additionally, odors would be localized and generally confined to the Project Area, which is generally devoid

of surrounding receptors. Therefore, odors generated during Project construction would not adversely affect a substantial number of people to odor emissions.

Land uses commonly considered to be potential sources of obnoxious odorous emissions include agriculture (farming and livestock), wastewater treatment plants, food processing plants, chemical plants, composting facilities, refineries, landfills, dairies, and fiberglass molding. The Proposed Project does not include any uses identified as being associated with odors.

3.0 GREENHOUSE GAS EMISSIONS

3.1 Greenhouse Gas Setting

Certain gases in the earth's atmosphere, classified as GHGs, play a critical role in determining the earth's surface temperature. Solar radiation enters the earth's atmosphere from space. A portion of the radiation is absorbed by the earth's surface and a smaller portion of this radiation is reflected back toward space. This absorbed radiation is then emitted from the earth as low-frequency infrared radiation. The frequencies at which bodies emit radiation are proportional to temperature. Because the earth has a much lower temperature than the sun, it emits lower-frequency radiation. Most solar radiation passes through GHGs; however, infrared radiation is absorbed by these gases. As a result, radiation that otherwise would have escaped back into space is instead trapped, resulting in a warming of the atmosphere. This phenomenon, known as the greenhouse effect, is responsible for maintaining a habitable climate on earth. Without the greenhouse effect, the earth would not be able to support life as we know it.

Prominent GHGs contributing to the greenhouse effect are CO₂, methane (CH₄), and N₂O. Fluorinated gases also make up a small fraction of the GHGs that contribute to climate change. Fluorinated gases include chlorofluorocarbons, hydrofluorocarbons, perfluorocarbons, sulfur hexafluoride, and nitrogen trifluoride; however, it is noted that these gases are not associated with typical land use development. Human-caused emissions of these GHGs in excess of natural ambient concentrations are believed to be responsible for intensifying the greenhouse effect and leading to a trend of unnatural warming of the earth's climate, known as global climate change or global warming. It is "extremely likely" that more than half of the observed increase in global average surface temperature from 1951 to 2010 was caused by the anthropogenic increase in GHG concentrations and other anthropogenic factors together (Intergovernmental Panel on Climate Change [IPCC] 2014).

Table 3-1 describes the primary GHGs attributed to global climate change, including their physical properties, primary sources, and contributions to the greenhouse effect.

Each GHG differs in its ability to absorb heat in the atmosphere based on the lifetime, or persistence, of the gas molecule in the atmosphere. CH₄ traps over 25 times more heat per molecule than CO₂, and N₂O absorbs 298 times more heat per molecule than CO₂ (IPCC 2014). Often, estimates of GHG emissions are presented in carbon dioxide equivalents (CO₂e), which weight each gas by its global warming potential. Expressing GHG emissions in CO₂e takes the contribution of all GHG emissions to the greenhouse effect and converts them to a single unit equivalent to the effect that would occur if only CO₂ were being emitted.

Climate change is a global problem. GHGs are global pollutants, unlike criteria air pollutants and TACs, which are pollutants of regional and local concern. Whereas pollutants with localized air quality effects have relatively short atmospheric lifetimes (about one day), GHGs have long atmospheric lifetimes (one to several thousand years). GHGs persist in the atmosphere for long enough time periods to be dispersed around the globe. Although the exact lifetime of any particular GHG molecule is dependent on multiple variables and cannot be pinpointed, it is understood that more CO₂ is emitted into the atmosphere than is sequestered by ocean uptake, vegetation, or other forms. Of the total annual human-caused CO₂ emissions, approximately 55 percent is sequestered through ocean and land uptakes every year, averaged over the

last 50 years, whereas the remaining 45 percent of human-caused CO₂ emissions remains stored in the atmosphere (IPCC 2013).

Table 3-1. Greenhouse Gases	
Greenhouse Gas	Description
CO ₂	Carbon dioxide is a colorless, odorless gas. CO ₂ is emitted in a number of ways, both naturally and through human activities. The largest source of CO ₂ emissions globally is the combustion of fossil fuels such as coal, oil, and gas in power plants, automobiles, industrial facilities, and other sources. A number of specialized industrial production processes and product uses such as mineral production, metal production, and the use of petroleum-based products can also lead to CO ₂ emissions. The atmospheric lifetime of CO ₂ is variable because it is so readily exchanged in the atmosphere. ¹
CH ₄	Methane is a colorless, odorless gas and is the major component of natural gas, about 87 percent by volume. It is also formed and released to the atmosphere by biological processes occurring in anaerobic environments. Methane is emitted from a variety of both human-related and natural sources. Human-related sources include fossil fuel production, animal husbandry (intestinal fermentation in livestock and manure management), rice cultivation, biomass burning, and waste management. These activities release significant quantities of CH ₄ to the atmosphere. Natural sources of CH ₄ include wetlands, gas hydrates, permafrost, termites, oceans, freshwater bodies, non-wetland soils, and other sources such as wildfires. The atmospheric lifetime of CH ₄ is about 12 years. ²
N ₂ O	Nitrous oxide is a clear, colorless gas with a slightly sweet odor. Nitrous oxide is produced by both natural and human-related sources. Primary human-related sources of N ₂ O are agricultural soil management, animal manure management, sewage treatment, mobile and stationary combustion of fossil fuels, adipic acid production, and nitric acid production. N ₂ O is also produced naturally from a wide variety of biological sources in soil and water, particularly microbial action in wet tropical forests. The atmospheric lifetime of N ₂ O is approximately 120 years. ³

Sources: ¹USEPA 2016a, ²USEPA 2016b, ³USEPA 2016c

The quantity of GHGs that it takes to ultimately result in climate change is not precisely known; it is sufficient to say the quantity is enormous, and no single project alone would measurably contribute to a noticeable incremental change in the global average temperature or to global, local, or microclimates. From the standpoint of CEQA, GHG impacts to global climate change are inherently cumulative.

3.1.1 Sources of Greenhouse Gas Emissions

In 2021, CARB released the 2021 edition of the California GHG inventory covering calendar year 2019 emissions. In 2019, California emitted 418.2 million gross metric tons of CO₂e including from imported electricity. Combustion of fossil fuel in the transportation sector was the single largest source of California's GHG emissions in 2019, accounting for approximately 40 percent of total GHG emissions in the State. When emissions from extracting, refining and moving transportation fuels in California are included, transportation is responsible for over 50 percent of statewide emissions in 2019. Continuing the downward trend from 2018, transportation emissions decreased 3.5 million metric tons of CO₂e in 2019, only being outpaced by electricity, which reduced emissions by 4.3 million metric tons of CO₂e in 2019. Emissions from

the electricity sector account for 14 percent of the inventory and have shown a substantial decrease in 2019 due to increases in renewables. California's industrial sector accounts for the second largest source of the State's GHG emissions in 2019, accounting for 21 percent (CARB 2021b).

3.2 Regulatory Framework

3.2.1 State

3.2.1.1 Executive Order S-3-05

Executive Order (EO) S-3-05, signed by Governor Arnold Schwarzenegger in 2005, proclaims that California is vulnerable to the impacts of climate change. It declares that increased temperatures could reduce the Sierra Nevada snowpack, further exacerbate California's air quality problems, and potentially cause a rise in sea levels. To combat those concerns, the EO established total GHG emission targets for the state. Specifically, emissions are to be reduced to the 2000 level by 2010, the 1990 level by 2020, and to 80 percent below the 1990 level by 2050.

3.2.1.2 Assembly Bill 32 Climate Change Scoping Plan and Updates

In 2006, the California legislature passed Assembly Bill (AB) 32 (Health and Safety Code § 38500 et seq., or AB 32), also known as the Global Warming Solutions Act. AB 32 required CARB to design and implement feasible and cost-effective emission limits, regulations, and other measures, such that statewide GHG emissions are reduced to 1990 levels by 2020 (representing a 25 percent reduction in emissions). Pursuant to AB 32, CARB adopted a Scoping Plan in December 2008, which outlined measures to meet the 2020 GHG reduction goals. California exceeded the target of reducing GHG emissions to 1990 levels by the year 2017.

The Scoping Plan is required by AB 32 to be updated at least every five years. The latest update, the 2017 Scoping Plan Update, addresses the 2030 target established by Senate Bill (SB) 32 as discussed below and establishes a proposed framework of action for California to meet a 40 percent reduction in GHG emissions by 2030 compared to 1990 levels. The key programs that the Scoping Plan Update builds on include increasing the use of renewable energy in the State, the Cap-and-Trade Regulation, the Low Carbon Fuel Standard, and reduction of methane emissions from agricultural and other wastes.

3.2.1.3 Senate Bill 32 and Assembly Bill 197 of 2016

In August 2016, Governor Brown signed SB 32 and AB 197, which serve to extend California's GHG reduction programs beyond 2020. SB 32 amended the Health and Safety Code to include § 38566, which contains language to authorize CARB to achieve a statewide GHG emission reduction of at least 40 percent below 1990 levels by no later than December 31, 2030.

3.2.1.4 Senate Bill 100 of 2018

In 2018, SB 100 was signed by Governor Brown, codifying a goal of 60 percent renewable procurement by 2030 and 100 percent by 2045 Renewables Portfolio Standard.

3.3 Greenhouse Gas Emissions Impact Assessment

3.3.1 Thresholds of Significance

The impact analysis provided below is based on the following CEQA Guidelines Appendix G thresholds of significance. The Project would result in a significant impact to GHG emissions if it would:

1. Generate GHG emissions, either directly or indirectly, that may have a significant impact on the environment.
2. Conflict with any applicable plan, policy, or regulation of an agency adopted for the purpose of reducing the emissions of greenhouse gases.

The Appendix G thresholds for GHG's do not prescribe specific methodologies for performing an assessment, do not establish specific thresholds of significance, and do not mandate specific mitigation measures. Rather, the CEQA Guidelines emphasize the lead agency's discretion to determine the appropriate methodologies and thresholds of significance consistent with the manner in which other impact areas are handled in CEQA. With respect to GHG emissions, the CEQA Guidelines § 15064.4(a) states that lead agencies "shall make a good-faith effort, based to the extent possible on scientific and factual data, to describe, calculate or estimate" GHG emissions resulting from a project. The CEQA Guidelines note that an agency has the discretion to either quantify a project's GHG emissions or rely on a "qualitative analysis or other performance-based standards." (14 California Code of Regulations [CCR] 15064.4(b)). A lead agency may use a "model or methodology" to estimate GHG emissions and has the discretion to select the model or methodology it considers "most appropriate to enable decision makers to intelligently take into account the project's incremental contribution to climate change." (14 CCR 15064.4(c)). Section 15064.4(b) provides that the lead agency should consider the following when determining the significance of impacts from GHG emissions on the environment:

1. The extent a project may increase or reduce GHG emissions as compared to the existing environmental setting.
2. Whether the project emissions exceed a threshold of significance that the lead agency determines applies to the project.
3. The extent to which the project complies with regulations or requirements adopted to implement a statewide, regional, or local plan for the reduction or mitigation of GHG emissions (14 CCR 15064.4(b)).

In addition, Section 15064.7(c) of the CEQA Guidelines specifies that "[w]hen adopting or using thresholds of significance, a lead agency may consider thresholds of significance previously adopted or recommended by other public agencies, or recommended by experts, provided the decision of the lead agency to adopt such thresholds is supported by substantial evidence" (14 CCR 15064.7(c)). The CEQA Guidelines also clarify that the effects of GHG emissions are cumulative and should be analyzed in the context of CEQA's requirements for cumulative impact analysis (see CEQA Guidelines § 15130(f)). As a note, the CEQA Guidelines were amended in response to SB 97. In particular, the CEQA Guidelines were amended to specify that compliance with a GHG emissions reduction plan renders a cumulative impact insignificant.

Per CEQA Guidelines § 15064(h)(3), a project's incremental contribution to a cumulative impact can be found not cumulatively considerable if the project would comply with an approved plan or mitigation program that provides specific requirements that would avoid or substantially lessen the cumulative problem within the geographic area of the project. To qualify, such plans or programs must be specified in law or adopted by the public agency with jurisdiction over the affected resources through a public review process to implement, interpret, or make specific the law enforced or administered by the public agency. Examples of such programs include a "water quality control plan, air quality attainment or maintenance plan, integrated waste management plan, habitat conservation plan, natural community conservation plans [and] plans or regulations for the reduction of greenhouse gas emissions." Put another way, CEQA Guidelines § 15064(h)(3) allows a lead agency to make a finding of less than significant for GHG emissions if a project complies with adopted programs, plans, policies and/or other regulatory strategies to reduce GHG emissions.

The significance of the Project's GHG emissions is evaluated consistent with CEQA Guidelines § 15064.4(b)(2) by considering whether the Project complies with applicable plans, policies, regulations and requirements adopted to implement a statewide, regional, or local plan for the reduction or mitigation of GHG emissions. The ICAPCD has not adopted a GHG significance threshold yet recommends the 100,000-metric ton of CO₂e threshold established by the Mojave Desert Air Quality Management District (MDAQMD). As previously described, Section 15064.7(c) of the CEQA Guidelines specifies that "[w]hen adopting or using thresholds of significance, a lead agency may consider thresholds of significance previously adopted or recommended by other public agencies, or recommended by experts, provided the decision of the lead agency to adopt such thresholds is supported by substantial evidence" (14 CCR 15064.7(c)). This ICAPCD-recommended threshold is appropriate as the MDAQMD GHG thresholds were formulated based on similar geography and climate patterns as found in Imperial County. Therefore, the 100,000-metric ton of CO₂e threshold is appropriate for this analysis.

In *Center for Biological Diversity v. Department of Fish and Wildlife* (2015) 62 Cal. 4th 2014, 213, 221, 227, following its review of various potential GHG thresholds proposed in an academic study [Crockett, *Addressing the Significance of Greenhouse Gas Emissions: California's Search for Regulatory Certainty in an Uncertain World* (July 2011), 4 Golden Gate U. Env'tl. L. J. 203], the California Supreme Court identified the use of numeric bright-line thresholds as a potential pathway for compliance with CEQA GHG requirements. The study found numeric bright line thresholds designed to determine when small projects were so small as to not cause a cumulatively considerable impact on global climate change was consistent with CEQA. Specifically, Public Resources Code section 21003(f) provides it is a policy of the state that "[a]ll persons and public agencies involved in the environmental review process be responsible for carrying out the process in the most efficient, expeditious manner in order to conserve the available financial, governmental, physical and social resources with the objective that those resources may be better applied toward the mitigation of actual significant effects on the environment." The Supreme Court-reviewed study noted, "[s]ubjecting the smallest projects to the full panoply of CEQA requirements, even though the public benefit would be minimal, would not be consistent with implementing the statute in the most efficient, expeditious manner. Nor would it be consistent with applying lead agencies' scarce resources toward mitigating actual significant climate change impacts." (Crockett, *Addressing the Significance of Greenhouse Gas Emissions: California's Search for Regulatory Certainty in an Uncertain World* (July 2011), 4 Golden Gate U. Env'tl. L. J. 203, 221, 227.)

3.3.2 Methodology

GHG-related impacts were assessed in accordance with methodologies recommended by the ICAPCD. Where GHG emission quantification was required, emissions were modeled using CalEEMod, version 2020.4.0. CalEEMod is a statewide land use emissions computer model designed to quantify potential GHG emissions associated with both construction and operations from a variety of land use projects. Project construction-generated GHG emissions were calculated using CalEEMod model defaults for Imperial County coupled with information provided by the Project applicant. For instance, as described in the Section 1.2, Project Overview, construction activities would primarily involve demolition and grubbing, grading of the Project Site to establish access roads and pads for electrical equipment, trenching for underground electrical collection lines, and the installation of solar equipment and security fencing. Construction is estimated to take 12-18 months and would begin in late 2022 or 2023. The number of on-site construction workers for the solar facility is not expected to exceed 150 workers at any time. The number of on-site construction workers for the BESS and substation is not expected to exceed 100 workers at any one time. According to the Traffic Study prepared for the Project (KOA 2020), Project construction would generate a maximum of 500 construction worker-commute trips in a single day.

Operational GHG emissions account for the maximum three workers visiting the site in a single day. Such visits include inspections, equipment servicing, site and landscape clearing, and periodic washing of the PV modules if needed (up to two times per year) to maintain power generation efficiency. Therefore, operational onsite equipment use is accounted in addition to the consumption of 10 acre-feet (3,259,000 gallons) of water annually.

3.3.3 Impact Analysis

3.3.3.1 Generation of GHG Emissions

Project Construction

Construction-related activities that would generate GHG emissions include worker commute trips, haul trucks carrying supplies and materials to and from the project site, and off-road construction equipment (e.g., dozers, loaders, excavators). Table 3-2 illustrates the specific construction generated GHG emissions that would result from construction of the Project. Consistent with SCAQMD recommendations, Project construction GHG emissions have been amortized over the expected life of the Project, which is considered to be 30 years for a solar energy generation facility. Once construction is complete, the generation of these GHG emissions would cease.

Table 3-2. Construction-Related Greenhouse Gas Emissions	
Emissions Source	CO₂e (Metric Tons/Year)
Construction Year One	913
Construction Year Two	611
<i>Significance Threshold</i>	<i>100,000</i>
<i>Exceed Significance Threshold?</i>	No

Source: CalEEMod version 2020.4.0. Refer to Attachment C for Model Data Outputs.

As shown in Table 3-2, Project would result in the generation of approximately 913 metric tons of CO₂e in the first calendar year of construction and 611 metric tons in the second calendar year of construction. Therefore, Project GHG emissions would not exceed the significance threshold.

Additionally, the Project proposes a solar energy generation facility intended to generate renewable energy. Solar plants generate far less GHG life-cycle emissions (approximately 83 to 94 percent less) than fossil-fueled energy plants. As identified in Table 3-5 below, the Project would potentially displace approximately 53,220 metric tons of CO₂e per year, and approximately 1,596,596 metric tons of CO₂e over the course of 30 years, which is considerably more than would be generated during construction.

Operations

Operation of the Project would result in an increase in GHG emissions. Long-term GHG emissions attributed to operations of the Project are identified in Table 3-3.

Table 3-3. Operational-Related Greenhouse Gas Emissions	
Emission Source	CO₂e (Metric Tons/ Year)
Area Source	0
Energy	1,088
Mobile	7
Offroad Equipment	8
Waste	82
Water	8
Total	1,194
Significance Threshold	100,000
Exceed Significance Threshold?	No

Source: CalEEMod version 2020.4.0. Refer to Attachment C for Model Data Outputs.

As shown in Table 3-3, operational-generated emissions would generate approximately 1,194 metric tons of GHG emissions and not exceed the significance threshold of 100,000 metric tons of CO₂e annually. As shown in Table 3-3, the majority of emissions are attributable to indirect energy consumption. The BESS component of the Project was modeled to account for HVAC use. However, this is potentially a conservative estimate since the energy source for the BESS HVAC could include the solar energy generated by the Project itself, which would be an emissions-free source of energy.

3.3.3.2 Conflict with any Applicable Plan, Policy, or Regulation of an Agency Adopted for the Purpose of Reducing the Emissions of Greenhouse Gases

The Project would not conflict with any adopted plans, policies, or regulations adopted for the purpose of reducing GHG emissions. The Proposed Project is subject to compliance with SB 32. As discussed previously, the Proposed Project-generated GHG emissions would not surpass either the ICAPCD-recommended GHG significance threshold, which was prepared with the purpose of complying with statewide GHG-reduction efforts. Additionally, once construction is complete, the Project would be a producer of renewable energy, which generates substantially less GHG emissions compared with the more common types of fossil-fueled energy generation facilities.

GHG emissions generated by energy sources account for all stages of the life cycle (including mining, construction, etc.), which are referred to as the cumulative GHG emissions and are usually expressed in grams of CO₂e per unit of busbar electricity (i.e., gCO₂/kWh_e). When comparing various fossil-fueled energy generators, the GHG emissions generated are dependent on the type of fuel (i.e., gas, oil, coal). GHG emissions generated by some of the more common types of fossil-fueled plants and solar-power plants are summarized in Table 3-4.

Table 3-4. Life-Cycle Greenhouse Gas Emissions for Various Types of Energy Generators	
Fossil Fueled	
Coal	950 to 1,250 gCO ₂ e/kWhe
Oil	500 to 1,200 gCO ₂ e/kWhe
Gas	440 to 780 gCO ₂ e/kWhe
Solar	43 to 73 ³ gCO ₂ e/kWhe

Source: Weisser 2007

Notes:

1 gCO₂e/kWhe = grams of CO₂e per unit of busbar electricity.

2 Emissions are based on lifecycle of energy source including mining, construction, operation, etc.

3 Solar PV life-cycle emissions result from using fossil-fuel-based energy to produce the materials for solar cells, modules, and systems, as well as directly from smelting, production, and manufacturing facilities.

As shown in Table 3-4, solar plants generate far less GHG life-cycle emissions (approximately 83 to 94 percent less) than fossil-fueled energy plants. Therefore, the Proposed Project would contribute to the continued reduction of GHG emissions in the interconnected California and western U.S. electricity systems, as the energy produced by the Project would displace GHG emissions that would otherwise be produced by existing business-as-usual power generation resources (including natural gas, coal, arid renewable combustion resources).

Table 3-5 shows the emissions that would potentially be displaced by the Proposed Project. Note that this estimate only includes that associated with the combustion of fossil fuels; it does not include the vehicle trips associated with the Project's operations, and it similarly does not include operational employee trips associated with natural gas or coal combustion nor the emissions associated with extracting and transporting those power sources. In addition, this estimate only includes the displacement of that portion of the California market that comes from fossil fuels and does not include the approximate 50 percent of the California electricity generated by non-combustion sources (wind, solar, nuclear, hydro-electric) (CEC 2020).

Table 3-5. Proposed Project Displaced GHG Emissions (Metric Tons)				
	Emissions (Metric Tons)			
	CO₂	CH₄	N₂O	CO₂e
Emissions Displaced Annually (metric tons)				
Displaced Natural Gas-Source Emissions	47,585	0.00	0.00	47,585
Displaced Coal-Source Emissions	5,626	0.037	0.028	5,635
Total	53,210	0.037	0.028	53,220
Emissions Displaced over 30 Years (metric tons)				
Total	1,596,309	1.118	0.838	1,596,596

Source: Displaced emissions calculated by ECORP using USEPA's AP-42 Fifth Edition Compilation of Air Emissions Factors 1995; 2015. See Attachment B.

Notes: In order to provide a conservative analysis, the proposed Project is assumed to generate electricity 25 percent of the time available (2,190 hours annually). Heat Rate indicates the energy generator efficiency of existing fossil-fuel based energy generators. The heat rate of a power plant measures the amount of fuel used to generate one unit of electricity. Power plants with lower heat rates are more efficient than plants with higher heat rates. The CEC's "Updated Thermal Power Plant Efficiency Measures and Operational Characteristics for Production Cost Modeling" (2019) estimates heat rates and operating ranges for thermal power plants supplying energy to California. The average heat rate of power plants types are as follows:

**Steam Boiler fueled by coal: 10,800 heat rate **Steam Boiler fueled by natural gas: 10,200 heat rate **Gas Turbine: 10,100 heat rate **Combined natural gas Boiler and Turbine: 7,640 heat rate.

By omitting steam boilers fueled by coal since so little of California's energy is derived from coal, the average heat rate = 9,313 $[(10,100 + 10,200 + 7,640) \div 3 = 9,313]$. 100 MW (219,000,000 annual kWh) x 9,313 heat rate = 2,039,547,000,000 Btu displaced from fossil fuel production. Fossil fuel-based energy consumption in California is predominately derived from natural gas (37.06 percent). Coal constitutes 2.74 percent of all fossil fuel-based energy. Therefore, 865,175,837,400 of the displaced Btu is displaced natural gas and unspecified nonrenewable sources consumption and 55,883,587,800 of the displaced Btu is displaced coal. The heat content of coal is assumed at 24 million Btu per ton of coal burned. At a rate of 24 million Btu per ton of coal burned, the Project would displace 2,328 tons of burned coal annually.

As shown, the Project would potentially displace approximately 53,220 metric tons of CO₂e per year, and approximately 1,596,596 metric tons of CO₂e over the course of 30 years.

While the Project would emit some GHG emissions during construction and a small amount during operations, the contribution of renewable resource energy production to meet the goals of the Renewable Portfolio Standard (Scoping Plan Measure E-3) would result in a net cumulative reduction of GHG emissions, a key environmental benefit. (Scoping Plan Measure E-3, Renewable Portfolio Standard, of the Climate Change Scoping Plan requires that all investor-owned utility companies generate 60 percent of their energy demand from renewable sources by year 2030.) Therefore, the short-term minor generation of GHG emissions during construction, which is necessary to create this new, low-GHG-emitting power-generating facility, as well as the negligible amount generated during ongoing maintenance operations, would be more than offset by GHG emission reductions associated with solar-generated energy during operation.

Increasing sources of solar energy is one of the measures identified under the Scoping Plan to reduce statewide GHG emissions. The Proposed Project would reduce GHG emissions in a manner consistent with SB 32 and other California GHG-reducing legislation by creating a new source of solar power to replace the current use of fossil-fuel power and reduce GHG emissions power generation and use.

The Project would not conflict with any applicable plan, policy, or regulation intended to reduce GHG emissions.

4.0 REFERENCES

- California Air Pollution Control Officers Association (CAPCOA). 2021. California Emissions Estimator Model (CalEEMod), version 2020.4.0.
- _____. 2013. Health Effects. <http://www.capcoa.org/health-effects/>.
- California Air Resources Board (CARB). 2021a. Air Quality Data Statistics. <http://www.arb.ca.gov/adam/index.html>.
- _____. 2021b. California Greenhouse Gas Emission Inventory 2021 Edition.
- _____. 2020b. Air Quality and Land Use Handbook
- _____. 2019. State and Federal Area Designation Maps. <http://www.arb.ca.gov/desig/adm/adm.htm>.
- California Energy Commission (CEC). 2020. 2020 Total System Electric Generation. <https://www.energy.ca.gov/data-reports/energy-almanac/california-electricity-data/2020-total-system-electric-generation>
- _____. 2019b. Updated Thermal Power Plant Efficiency Measures and Operational Characteristics for Production Cost Modeling.
- Crockett, Alexander G. 2011. Addressing the Significance of Greenhouse Gas Emissions Under CEQA: California's Search for Regulatory Certainty in an Uncertain World.
- Intergovernmental Panel on Climate Change (IPCC). 2014. Climate Change 2014 Synthesis Report: Approved Summary for Policymakers. <http://www.ipcc.ch/>.
- _____. 2013. Carbon and Other Biogeochemical Cycles. In: Climate Change 2013: The Physical Science Basis. Contribution of Working Group I to the Fifth Assessment Report of the Intergovernmental Panel on Climate Change. http://www.climatechange2013.org/images/report/WG1AR5_ALL_FINAL.pdf.
- Imperial County Air Pollution Control District (ICAPCD). 2021. Email communication with Monica Soucier.
- _____. 2017. *Air Quality Handbook*.
- _____. 2010. *Final 2009 1997 8-Hour Ozone Modified Air Quality Management Plan*.
- KOA. 2020. Scoping Memorandum for Traffic Impact Study.
- South Coast Air Quality Management District (SCAQMD). 2003. Air Quality Management Plan.
- _____. 1992. 1992 Federal Attainment Plan for Carbon Monoxide.
- U.S. Environmental Protection Agency (USEPA). 2016a. Climate Change – Greenhouse Gas Emissions: Carbon Dioxide. <http://www.epa.gov/climatechange/emissions/co2.html>.
- _____. 2016b. Methane. <https://www3.epa.gov/climatechange/ghgemissions/gases/ch4.html>.

_____. 2016c. Nitrous Oxide. <https://www3.epa.gov/climatechange/ghgemissions/gases/n2o.html>.

_____. 2002. Health Assessment Document for Diesel Engine Exhaust.
<https://nepis.epa.gov/Exe/ZyPURL.cgi?Dockkey=300055PV.TXT>.

Weisser, Daniel. 2007. A Guide to Life-Cycle Greenhouse Gas (GHG) Emissions from Electric Supply Technologies. *Energy* 32 (9), 1543–1559.

LIST OF ATTACHMENTS

Attachment A – CalEEMod Output Files Criteria Air Pollutants

Attachment B – Renewable Energy Emissions Displacement

Attachment C – CalEEMod Output Files Greenhouse Gas Emissions

CalEEMod Output Files Criteria Air Pollutants

Vega SES 4 Solar Energy Storage Project - Imperial County, Summer

EMFAC Off-Model Adjustment Factors for Gasoline Light Duty Vehicle to Account for the SAFE Vehicle Rule Not Applied

**Vega SES 4 Solar Energy Storage Project
Imperial County, Summer**

1.0 Project Characteristics

1.1 Land Usage

Land Uses	Size	Metric	Lot Acreage	Floor Surface Area	Population
Other Non-Asphalt Surfaces	447.00	Acre	447.00	19,471,320.00	0
Refrigerated Warehouse-No Rail	87.12	1000sqft	2.00	87,120.00	0
Refrigerated Warehouse-No Rail	87.12	1000sqft	2.00	87,120.00	0
Other Non-Asphalt Surfaces	3.50	Acre	3.50	152,460.00	0

1.2 Other Project Characteristics

Urbanization	Rural	Wind Speed (m/s)	3.4	Precipitation Freq (Days)	12
Climate Zone	15			Operational Year	2023
Utility Company	Imperial Irrigation District				
CO2 Intensity (lb/MWhr)	189.98	CH4 Intensity (lb/MWhr)	0.033	N2O Intensity (lb/MWhr)	0.004

1.3 User Entered Comments & Non-Default Data

Project Characteristics -

Land Use - Land Uses account for 447 acres of solar field, 2 acres of BESS, 2 acres of Substation, and 3.5 acres of Staging/Parking Area

Construction Phase - Construction timing per Project Applicant

Off-road Equipment - Construction equipment per Project applicant. Plate compactor = pile driver.

Off-road Equipment - Ibid

Off-road Equipment - Construction equipment per Project applicant.

Trips and VMT - Maximun 500 worker commute trips per Traffic Study. 20.25 miles added to vendor route for extended access along border.

On-road Fugitive Dust - 89% paved roads for worker commutes [1.15 m dirt roads / 10.2 m trip length default = 89% paved roads]. Traffic Study identifies worker commute routes north of Staging/Parking Area as 100% paved. 37% paved for vendor/equipment hauling trips. Trips require additional 20.25 miles of distance on dirt roadway.

PC ORIGINAL PKG

Vega SES 4 Solar Energy Storage Project - Imperial County, Summer

EMFAC Off-Model Adjustment Factors for Gasoline Light Duty Vehicle to Account for the SAFE Vehicle Rule Not Applied

Grading -

Vehicle Trips - Maximum daily trips = 6 per Traffic Study

Road Dust - 92% paved roads for operational worker commutes [1.15 m dirt roads / 14.55 m trip length default weighted average = 92% paved roads].

Energy Use - Solar facility- no operational energy use.

Water And Wastewater - Water use being kept for light industrial land use as the solar panels may need to be cleaned.

Solid Waste - No solid waste- solar facility.

Construction Off-road Equipment Mitigation - Mitigation measure AQ-1 accounted. PM Reduction value for applying soil stabilizers to unpaved roadways per communication with ICAPCD (Monica Soucier via email correspondence).

Mobile Land Use Mitigation -

Energy Mitigation -

Operational Off-Road Equipment - Onsite maintenance expected 4 times annually.

Table Name	Column Name	Default Value	New Value
tblConstDustMitigation	WaterUnpavedRoadVehicleSpeed	40	15
tblConstructionPhase	NumDays	7,750.00	286.00
tblConstructionPhase	NumDays	775.00	66.00
tblConstructionPhase	NumDays	300.00	33.00
tblConstructionPhase	PhaseEndDate	9/30/2055	7/25/2024
tblConstructionPhase	PhaseEndDate	1/15/2026	6/21/2023
tblConstructionPhase	PhaseEndDate	1/26/2023	3/21/2023
tblConstructionPhase	PhaseStartDate	1/16/2026	6/22/2023
tblConstructionPhase	PhaseStartDate	1/27/2023	3/22/2023
tblConstructionPhase	PhaseStartDate	12/3/2021	2/3/2023
tblOffRoadEquipment	LoadFactor	0.36	0.36
tblOffRoadEquipment	LoadFactor	0.40	0.40
tblOffRoadEquipment	LoadFactor	0.42	0.42
tblOffRoadEquipment	LoadFactor	0.36	0.36
tblOffRoadEquipment	LoadFactor	0.50	0.50
tblOffRoadEquipment	LoadFactor	0.38	0.38
tblOffRoadEquipment	OffRoadEquipmentType	PC ORIGINAL PKG	Rubber Tired Loaders

Vega SES 4 Solar Energy Storage Project - Imperial County, Summer

EMFAC Off-Model Adjustment Factors for Gasoline Light Duty Vehicle to Account for the SAFE Vehicle Rule Not Applied

tblOffRoadEquipment	OffRoadEquipmentType		Rough Terrain Forklifts
tblOffRoadEquipment	OffRoadEquipmentType		Pavers
tblOffRoadEquipment	OffRoadEquipmentType		Paving Equipment
tblOffRoadEquipment	OffRoadEquipmentType		Plate Compactors
tblOffRoadEquipment	OffRoadEquipmentType		Trenchers
tblOffRoadEquipment	OffRoadEquipmentType		Rollers
tblOffRoadEquipment	OffRoadEquipmentUnitAmount	2.00	4.00
tblOffRoadEquipment	OffRoadEquipmentUnitAmount	3.00	0.00
tblOffRoadEquipment	OffRoadEquipmentUnitAmount	1.00	0.00
tblOffRoadEquipment	OffRoadEquipmentUnitAmount	1.00	3.00
tblOffRoadEquipment	OffRoadEquipmentUnitAmount	1.00	2.00
tblOffRoadEquipment	OffRoadEquipmentUnitAmount	3.00	0.00
tblOffRoadEquipment	OffRoadEquipmentUnitAmount	3.00	4.00
tblOffRoadEquipment	OffRoadEquipmentUnitAmount	2.00	4.00
tblOffRoadEquipment	OffRoadEquipmentUnitAmount	4.00	2.00
tblOffRoadEquipment	OffRoadEquipmentUnitAmount	1.00	0.00
tblOnRoadDust	VendorPercentPave	50.00	37.00
tblOnRoadDust	VendorPercentPave	50.00	37.00
tblOnRoadDust	VendorPercentPave	50.00	37.00
tblOnRoadDust	WorkerPercentPave	50.00	89.00
tblOnRoadDust	WorkerPercentPave	50.00	89.00
tblOnRoadDust	WorkerPercentPave	50.00	89.00
tblOperationalOffRoadEquipment	OperDaysPerYear	260.00	8.00
tblOperationalOffRoadEquipment	OperDaysPerYear	260.00	8.00
tblOperationalOffRoadEquipment	OperHoursPerDay	8.00	2.00
tblOperationalOffRoadEquipment	OperLoadFactor	0.42	0.42
tblOperationalOffRoadEquipment	OperLoadFactor	0.38	0.38
tblOperationalOffRoadEquipment	OperOffRoadEquipmentNumber	0.00	3.00
tblOperationalOffRoadEquipment	OperOffRoadEquipmentNumber	0.00	1.00

PC ORIGINAL PKG

Vega SES 4 Solar Energy Storage Project - Imperial County, Summer

EMFAC Off-Model Adjustment Factors for Gasoline Light Duty Vehicle to Account for the SAFE Vehicle Rule Not Applied

tblProjectCharacteristics	UrbanizationLevel	Urban	Rural
tblRoadDust	RoadPercentPave	50	92
tblTripsAndVMT	VendorTripLength	11.90	32.15
tblTripsAndVMT	VendorTripLength	11.90	32.15
tblTripsAndVMT	VendorTripLength	11.90	32.15
tblTripsAndVMT	VendorTripNumber	0.00	4.00
tblTripsAndVMT	VendorTripNumber	0.00	4.00
tblTripsAndVMT	VendorTripNumber	3,245.00	4.00
tblTripsAndVMT	WorkerTripNumber	8,315.00	500.00
tblVehicleTrips	ST_TR	2.12	0.00
tblVehicleTrips	SU_TR	2.12	0.00
tblVehicleTrips	WD_TR	2.12	0.03
tblWater	IndoorWaterUseRate	40,293,000.00	3,259,000.00

2.0 Emissions Summary

Vega SES 4 Solar Energy Storage Project - Imperial County, Summer

EMFAC Off-Model Adjustment Factors for Gasoline Light Duty Vehicle to Account for the SAFE Vehicle Rule Not Applied

2.1 Overall Construction (Maximum Daily Emission)

Unmitigated Construction

	ROG	NOx	CO	SO2	Fugitive PM10	Exhaust PM10	PM10 Total	Fugitive PM2.5	Exhaust PM2.5	PM2.5 Total	Bio- CO2	NBio- CO2	Total CO2	CH4	N2O	CO2e
Year	lb/day										lb/day					
2023	5.6636	57.6100	53.8307	0.1062	948.4182	2.3569	949.9344	95.2426	2.1685	96.6408	0.0000	10,324.71 67	10,324.71 67	3.1545	0.1515	10,419.20 84
2024	5.1830	30.0350	52.4623	0.0944	948.4182	1.4097	949.8279	95.2426	1.3002	96.5428	0.0000	9,265.731 2	9,265.731 2	1.8251	0.1426	9,353.850 8
Maximum	5.6636	57.6100	53.8307	0.1062	948.4182	2.3569	949.9344	95.2426	2.1685	96.6408	0.0000	10,324.71 67	10,324.71 67	3.1545	0.1515	10,419.20 84

Mitigated Construction

	ROG	NOx	CO	SO2	Fugitive PM10	Exhaust PM10	PM10 Total	Fugitive PM2.5	Exhaust PM2.5	PM2.5 Total	Bio- CO2	NBio- CO2	Total CO2	CH4	N2O	CO2e
Year	lb/day										lb/day					
2023	5.6636	57.6100	53.8307	0.1062	90.3461	2.3569	91.8623	9.6062	2.1685	11.0044	0.0000	10,324.71 67	10,324.71 67	3.1545	0.1515	10,419.20 84
2024	5.1830	30.0350	52.4623	0.0944	90.3461	1.4097	91.7558	9.6062	1.3002	10.9064	0.0000	9,265.731 2	9,265.731 2	1.8251	0.1426	9,353.850 8
Maximum	5.6636	57.6100	53.8307	0.1062	90.3461	2.3569	91.8623	9.6062	2.1685	11.0044	0.0000	10,324.71 67	10,324.71 67	3.1545	0.1515	10,419.20 84

Vega SES 4 Solar Energy Storage Project - Imperial County, Summer

EMFAC Off-Model Adjustment Factors for Gasoline Light Duty Vehicle to Account for the SAFE Vehicle Rule Not Applied

	ROG	NOx	CO	SO2	Fugitive PM10	Exhaust PM10	PM10 Total	Fugitive PM2.5	Exhaust PM2.5	PM2.5 Total	Bio- CO2	NBio-CO2	Total CO2	CH4	N2O	CO2e
Percent Reduction	0.00	0.00	0.00	0.00	90.47	0.00	90.33	89.91	0.00	88.66	0.00	0.00	0.00	0.00	0.00	0.00

2.2 Overall Operational

Unmitigated Operational

	ROG	NOx	CO	SO2	Fugitive PM10	Exhaust PM10	PM10 Total	Fugitive PM2.5	Exhaust PM2.5	PM2.5 Total	Bio- CO2	NBio- CO2	Total CO2	CH4	N2O	CO2e
Category	lb/day										lb/day					
Area	13.5919	5.8000e-004	0.0638	0.0000		2.3000e-004	2.3000e-004		2.3000e-004	2.3000e-004		0.1367	0.1367	3.6000e-004		0.1457
Energy	0.2663	2.4210	2.0337	0.0145		0.1840	0.1840		0.1840	0.1840		2,905.2168	2,905.2168	0.0557	0.0533	2,922.4811
Mobile	0.0294	0.0355	0.3113	6.4000e-004	4.8460	4.4000e-004	4.8464	0.4922	4.1000e-004	0.4927		64.8492	64.8492	2.6500e-003	2.7400e-003	65.7319
Offroad	1.1604	11.0968	12.7025	0.0217		0.5634	0.5634		0.5184	0.5184	0.0000	2,096.6998	2,096.6998	0.6781		2,113.6527
Total	15.0481	13.5539	15.1112	0.0368	4.8460	0.7481	5.5941	0.4922	0.7030	1.1952	0.0000	5,066.9026	5,066.9026	0.7368	0.0560	5,102.0114

Vega SES 4 Solar Energy Storage Project - Imperial County, Summer

EMFAC Off-Model Adjustment Factors for Gasoline Light Duty Vehicle to Account for the SAFE Vehicle Rule Not Applied

2.2 Overall Operational

Mitigated Operational

	ROG	NOx	CO	SO2	Fugitive PM10	Exhaust PM10	PM10 Total	Fugitive PM2.5	Exhaust PM2.5	PM2.5 Total	Bio- CO2	NBio- CO2	Total CO2	CH4	N2O	CO2e
Category	lb/day										lb/day					
Area	13.5919	5.8000e-004	0.0638	0.0000		2.3000e-004	2.3000e-004		2.3000e-004	2.3000e-004		0.1367	0.1367	3.6000e-004		0.1457
Energy	0.2663	2.4210	2.0337	0.0145		0.1840	0.1840		0.1840	0.1840		2,905.2168	2,905.2168	0.0557	0.0533	2,922.4811
Mobile	0.0294	0.0355	0.3113	6.4000e-004	4.8460	4.4000e-004	4.8464	0.4922	4.1000e-004	0.4927		64.8492	64.8492	2.6500e-003	2.7400e-003	65.7319
Offroad	1.1604	11.0968	12.7025	0.0217		0.5634	0.5634		0.5184	0.5184	0.0000	2,096.6998	2,096.6998	0.6781		2,113.6527
Total	15.0481	13.5539	15.1112	0.0368	4.8460	0.7481	5.5941	0.4922	0.7030	1.1952	0.0000	5,066.9026	5,066.9026	0.7368	0.0560	5,102.0114

	ROG	NOx	CO	SO2	Fugitive PM10	Exhaust PM10	PM10 Total	Fugitive PM2.5	Exhaust PM2.5	PM2.5 Total	Bio- CO2	NBio- CO2	Total CO2	CH4	N2O	CO2e
Percent Reduction	0.00	0.00	0.00	0.00	0.00	0.00	0.00	0.00	0.00	0.00	0.00	0.00	0.00	0.00	0.00	0.00

3.0 Construction Detail

Construction Phase

Phase Number	Phase Name	Phase Type	Start Date	End Date	Num Days Week	Num Days	Phase Description
1	Site Preparation	Site Preparation	2/3/2023	3/21/2023	5	33	
2	Grading	Grading	3/22/2023	6/21/2023	5	66	
3	Building Construction	Building Construction	6/22/2023	7/25/2024	5	286	

Acres of Grading (Site Preparation Phase): 0

PC ORIGINAL PKG

Vega SES 4 Solar Energy Storage Project - Imperial County, Summer

EMFAC Off-Model Adjustment Factors for Gasoline Light Duty Vehicle to Account for the SAFE Vehicle Rule Not Applied

Acres of Grading (Grading Phase): 297

Acres of Paving: 450.5

Residential Indoor: 0; Residential Outdoor: 0; Non-Residential Indoor: 0; Non-Residential Outdoor: 0; Striped Parking Area: 0 (Architectural Coating – sqft)

OffRoad Equipment

Phase Name	Offroad Equipment Type	Amount	Usage Hours	Horse Power	Load Factor
Site Preparation	Rubber Tired Dozers	0	8.00	247	0.40
Site Preparation	Tractors/Loaders/Backhoes	2	8.00	97	0.37
Grading	Excavators	4	8.00	158	0.38
Grading	Graders	3	8.00	187	0.41
Grading	Rubber Tired Dozers	2	8.00	247	0.40
Grading	Scrapers	2	8.00	367	0.48
Grading	Tractors/Loaders/Backhoes	4	8.00	97	0.37
Building Construction	Cranes	1	7.00	231	0.29
Building Construction	Forklifts	0	8.00	89	0.20
Building Construction	Generator Sets	0	8.00	84	0.74
Site Preparation	Rubber Tired Loaders	2	8.00	203	0.36
Building Construction	Rough Terrain Forklifts	4	8.00	100	0.40
Building Construction	Pavers	1	8.00	130	0.42
Building Construction	Tractors/Loaders/Backhoes	4	7.00	97	0.37
Building Construction	Paving Equipment	2	8.00	132	0.36
Building Construction	Welders	0	8.00	46	0.45
Building Construction	Plate Compactors	4	8.00	8	0.43
Building Construction	Trenchers	2	8.00	78	0.50
Building Construction	Rollers	2	8.00	80	0.38

Trips and VMT

Vega SES 4 Solar Energy Storage Project - Imperial County, Summer

EMFAC Off-Model Adjustment Factors for Gasoline Light Duty Vehicle to Account for the SAFE Vehicle Rule Not Applied

Phase Name	Offroad Equipment Count	Worker Trip Number	Vendor Trip Number	Hauling Trip Number	Worker Trip Length	Vendor Trip Length	Hauling Trip Length	Worker Vehicle Class	Vendor Vehicle Class	Hauling Vehicle Class
Site Preparation	4	10.00	4.00	0.00	10.20	32.15	20.00	LD_Mix	HDT_Mix	HHDT
Grading	15	38.00	4.00	0.00	10.20	32.15	20.00	LD_Mix	HDT_Mix	HHDT
Building Construction	20	500.00	4.00	0.00	10.20	32.15	20.00	LD_Mix	HDT_Mix	HHDT

3.1 Mitigation Measures Construction

- Use Soil Stabilizer
- Water Exposed Area
- Water Unpaved Roads
- Reduce Vehicle Speed on Unpaved Roads

3.2 Site Preparation - 2023

Unmitigated Construction On-Site

	ROG	NOx	CO	SO2	Fugitive PM10	Exhaust PM10	PM10 Total	Fugitive PM2.5	Exhaust PM2.5	PM2.5 Total	Bio- CO2	NBio- CO2	Total CO2	CH4	N2O	CO2e
Category	lb/day										lb/day					
Fugitive Dust					0.0000	0.0000	0.0000	0.0000	0.0000	0.0000			0.0000			0.0000
Off-Road	0.8464	8.4073	7.4973	0.0188		0.3303	0.3303		0.3039	0.3039		1,820.3309	1,820.3309	0.5887		1,835.0492
Total	0.8464	8.4073	7.4973	0.0188	0.0000	0.3303	0.3303	0.0000	0.3039	0.3039		1,820.3309	1,820.3309	0.5887		1,835.0492

Vega SES 4 Solar Energy Storage Project - Imperial County, Summer

EMFAC Off-Model Adjustment Factors for Gasoline Light Duty Vehicle to Account for the SAFE Vehicle Rule Not Applied

3.2 Site Preparation - 2023

Unmitigated Construction Off-Site

	ROG	NOx	CO	SO2	Fugitive PM10	Exhaust PM10	PM10 Total	Fugitive PM2.5	Exhaust PM2.5	PM2.5 Total	Bio- CO2	NBio- CO2	Total CO2	CH4	N2O	CO2e
Category	lb/day										lb/day					
Hauling	0.0000	0.0000	0.0000	0.0000	0.0000	0.0000	0.0000	0.0000	0.0000	0.0000		0.0000	0.0000	0.0000	0.0000	0.0000
Vendor	0.0199	0.4045	0.1319	3.0800e-003	119.2980	5.2500e-003	119.3033	11.9190	5.0300e-003	11.9240		324.2947	324.2947	9.3000e-004	0.0443	337.5192
Worker	0.0501	0.0232	0.3497	7.2000e-004	16.5824	3.8000e-004	16.5828	1.6665	3.5000e-004	1.6668		72.8603	72.8603	2.3100e-003	2.1400e-003	73.5570
Total	0.0700	0.4277	0.4816	3.8000e-003	135.8804	5.6300e-003	135.8860	13.5855	5.3800e-003	13.5909		397.1550	397.1550	3.2400e-003	0.0464	411.0761

Mitigated Construction On-Site

	ROG	NOx	CO	SO2	Fugitive PM10	Exhaust PM10	PM10 Total	Fugitive PM2.5	Exhaust PM2.5	PM2.5 Total	Bio- CO2	NBio- CO2	Total CO2	CH4	N2O	CO2e
Category	lb/day										lb/day					
Fugitive Dust					0.0000	0.0000	0.0000	0.0000	0.0000	0.0000			0.0000			0.0000
Off-Road	0.8464	8.4073	7.4973	0.0188		0.3303	0.3303		0.3039	0.3039	0.0000	1,820.3309	1,820.3309	0.5887		1,835.0492
Total	0.8464	8.4073	7.4973	0.0188	0.0000	0.3303	0.3303	0.0000	0.3039	0.3039	0.0000	1,820.3309	1,820.3309	0.5887		1,835.0492

Vega SES 4 Solar Energy Storage Project - Imperial County, Summer

EMFAC Off-Model Adjustment Factors for Gasoline Light Duty Vehicle to Account for the SAFE Vehicle Rule Not Applied

3.2 Site Preparation - 2023

Mitigated Construction Off-Site

	ROG	NOx	CO	SO2	Fugitive PM10	Exhaust PM10	PM10 Total	Fugitive PM2.5	Exhaust PM2.5	PM2.5 Total	Bio- CO2	NBio- CO2	Total CO2	CH4	N2O	CO2e
Category	lb/day										lb/day					
Hauling	0.0000	0.0000	0.0000	0.0000	0.0000	0.0000	0.0000	0.0000	0.0000	0.0000		0.0000	0.0000	0.0000	0.0000	0.0000
Vendor	0.0199	0.4045	0.1319	3.0800e-003	11.0155	5.2500e-003	11.0208	1.1123	5.0300e-003	1.1173		324.2947	324.2947	9.3000e-004	0.0443	337.5192
Worker	0.0501	0.0232	0.3497	7.2000e-004	1.5866	3.8000e-004	1.5870	0.1699	3.5000e-004	0.1702		72.8603	72.8603	2.3100e-003	2.1400e-003	73.5570
Total	0.0700	0.4277	0.4816	3.8000e-003	12.6022	5.6300e-003	12.6078	1.2822	5.3800e-003	1.2876		397.1550	397.1550	3.2400e-003	0.0464	411.0761

3.3 Grading - 2023

Unmitigated Construction On-Site

	ROG	NOx	CO	SO2	Fugitive PM10	Exhaust PM10	PM10 Total	Fugitive PM2.5	Exhaust PM2.5	PM2.5 Total	Bio- CO2	NBio- CO2	Total CO2	CH4	N2O	CO2e
Category	lb/day										lb/day					
Fugitive Dust					16.8164	0.0000	16.8164	7.1358	0.0000	7.1358			0.0000			0.0000
Off-Road	5.4534	57.1174	45.5209	0.1004		2.3502	2.3502		2.1621	2.1621		9,723.5530	9,723.5530	3.1448		9,802.1729
Total	5.4534	57.1174	45.5209	0.1004	16.8164	2.3502	19.1666	7.1358	2.1621	9.2979		9,723.5530	9,723.5530	3.1448		9,802.1729

Vega SES 4 Solar Energy Storage Project - Imperial County, Summer

EMFAC Off-Model Adjustment Factors for Gasoline Light Duty Vehicle to Account for the SAFE Vehicle Rule Not Applied

3.3 Grading - 2023

Unmitigated Construction Off-Site

	ROG	NOx	CO	SO2	Fugitive PM10	Exhaust PM10	PM10 Total	Fugitive PM2.5	Exhaust PM2.5	PM2.5 Total	Bio- CO2	NBio- CO2	Total CO2	CH4	N2O	CO2e
Category	lb/day										lb/day					
Hauling	0.0000	0.0000	0.0000	0.0000	0.0000	0.0000	0.0000	0.0000	0.0000	0.0000		0.0000	0.0000	0.0000	0.0000	0.0000
Vendor	0.0199	0.4045	0.1319	3.0800e-003	119.2980	5.2500e-003	119.3033	11.9190	5.0300e-003	11.9240		324.2947	324.2947	9.3000e-004	0.0443	337.5192
Worker	0.1903	0.0881	1.3288	2.7400e-003	63.0131	1.4600e-003	63.0146	6.3326	1.3500e-003	6.3339		276.8690	276.8690	8.7600e-003	8.1500e-003	279.5164
Total	0.2102	0.4926	1.4607	5.8200e-003	182.3111	6.7100e-003	182.3179	18.2516	6.3800e-003	18.2580		601.1637	601.1637	9.6900e-003	0.0525	617.0356

Mitigated Construction On-Site

	ROG	NOx	CO	SO2	Fugitive PM10	Exhaust PM10	PM10 Total	Fugitive PM2.5	Exhaust PM2.5	PM2.5 Total	Bio- CO2	NBio- CO2	Total CO2	CH4	N2O	CO2e
Category	lb/day										lb/day					
Fugitive Dust					6.5584	0.0000	6.5584	2.7829	0.0000	2.7829			0.0000			0.0000
Off-Road	5.4534	57.1174	45.5209	0.1004		2.3502	2.3502		2.1621	2.1621	0.0000	9,723.5530	9,723.5530	3.1448		9,802.1729
Total	5.4534	57.1174	45.5209	0.1004	6.5584	2.3502	8.9086	2.7829	2.1621	4.9451	0.0000	9,723.5530	9,723.5530	3.1448		9,802.1729

Vega SES 4 Solar Energy Storage Project - Imperial County, Summer

EMFAC Off-Model Adjustment Factors for Gasoline Light Duty Vehicle to Account for the SAFE Vehicle Rule Not Applied

3.3 Grading - 2023

Mitigated Construction Off-Site

	ROG	NOx	CO	SO2	Fugitive PM10	Exhaust PM10	PM10 Total	Fugitive PM2.5	Exhaust PM2.5	PM2.5 Total	Bio- CO2	NBio- CO2	Total CO2	CH4	N2O	CO2e
Category	lb/day										lb/day					
Hauling	0.0000	0.0000	0.0000	0.0000	0.0000	0.0000	0.0000	0.0000	0.0000	0.0000		0.0000	0.0000	0.0000	0.0000	0.0000
Vendor	0.0199	0.4045	0.1319	3.0800e-003	11.0155	5.2500e-003	11.0208	1.1123	5.0300e-003	1.1173		324.2947	324.2947	9.3000e-004	0.0443	337.5192
Worker	0.1903	0.0881	1.3288	2.7400e-003	6.0291	1.4600e-003	6.0306	0.6455	1.3500e-003	0.6469		276.8690	276.8690	8.7600e-003	8.1500e-003	279.5164
Total	0.2102	0.4926	1.4607	5.8200e-003	17.0447	6.7100e-003	17.0514	1.7578	6.3800e-003	1.7642		601.1637	601.1637	9.6900e-003	0.0525	617.0356

3.4 Building Construction - 2023

Unmitigated Construction On-Site

	ROG	NOx	CO	SO2	Fugitive PM10	Exhaust PM10	PM10 Total	Fugitive PM2.5	Exhaust PM2.5	PM2.5 Total	Bio- CO2	NBio- CO2	Total CO2	CH4	N2O	CO2e
Category	lb/day										lb/day					
Off-Road	2.9498	30.0468	36.2147	0.0564		1.4917	1.4917		1.3755	1.3755		5,412.1870	5,412.1870	1.7201		5,455.1901
Total	2.9498	30.0468	36.2147	0.0564		1.4917	1.4917		1.3755	1.3755		5,412.1870	5,412.1870	1.7201		5,455.1901

Vega SES 4 Solar Energy Storage Project - Imperial County, Summer

EMFAC Off-Model Adjustment Factors for Gasoline Light Duty Vehicle to Account for the SAFE Vehicle Rule Not Applied

3.4 Building Construction - 2023

Unmitigated Construction Off-Site

	ROG	NOx	CO	SO2	Fugitive PM10	Exhaust PM10	PM10 Total	Fugitive PM2.5	Exhaust PM2.5	PM2.5 Total	Bio- CO2	NBio- CO2	Total CO2	CH4	N2O	CO2e
Category	lb/day										lb/day					
Hauling	0.0000	0.0000	0.0000	0.0000	0.0000	0.0000	0.0000	0.0000	0.0000	0.0000		0.0000	0.0000	0.0000	0.0000	0.0000
Vendor	0.0199	0.4045	0.1319	3.0800e-003	119.2980	5.2500e-003	119.3033	11.9190	5.0300e-003	11.9240		324.2947	324.2947	9.3000e-004	0.0443	337.5192
Worker	2.5037	1.1587	17.4841	0.0360	829.1202	0.0192	829.1395	83.3236	0.0177	83.3413		3,643.0131	3,643.0131	0.1153	0.1072	3,677.8475
Total	2.5236	1.5632	17.6160	0.0391	948.4182	0.0245	948.4427	95.2426	0.0227	95.2653		3,967.3078	3,967.3078	0.1162	0.1515	4,015.3666

Mitigated Construction On-Site

	ROG	NOx	CO	SO2	Fugitive PM10	Exhaust PM10	PM10 Total	Fugitive PM2.5	Exhaust PM2.5	PM2.5 Total	Bio- CO2	NBio- CO2	Total CO2	CH4	N2O	CO2e
Category	lb/day										lb/day					
Off-Road	2.9498	30.0468	36.2147	0.0564		1.4917	1.4917		1.3755	1.3755	0.0000	5,412.1870	5,412.1870	1.7201		5,455.1901
Total	2.9498	30.0468	36.2147	0.0564		1.4917	1.4917		1.3755	1.3755	0.0000	5,412.1870	5,412.1870	1.7201		5,455.1901

Vega SES 4 Solar Energy Storage Project - Imperial County, Summer

EMFAC Off-Model Adjustment Factors for Gasoline Light Duty Vehicle to Account for the SAFE Vehicle Rule Not Applied

3.4 Building Construction - 2023

Mitigated Construction Off-Site

	ROG	NOx	CO	SO2	Fugitive PM10	Exhaust PM10	PM10 Total	Fugitive PM2.5	Exhaust PM2.5	PM2.5 Total	Bio- CO2	NBio- CO2	Total CO2	CH4	N2O	CO2e
Category	lb/day										lb/day					
Hauling	0.0000	0.0000	0.0000	0.0000	0.0000	0.0000	0.0000	0.0000	0.0000	0.0000		0.0000	0.0000	0.0000	0.0000	0.0000
Vendor	0.0199	0.4045	0.1319	3.0800e-003	11.0155	5.2500e-003	11.0208	1.1123	5.0300e-003	1.1173		324.2947	324.2947	9.3000e-004	0.0443	337.5192
Worker	2.5037	1.1587	17.4841	0.0360	79.3306	0.0192	79.3498	8.4939	0.0177	8.5116		3,643.0131	3,643.0131	0.1153	0.1072	3,677.8475
Total	2.5236	1.5632	17.6160	0.0391	90.3461	0.0245	90.3706	9.6062	0.0227	9.6289		3,967.3078	3,967.3078	0.1162	0.1515	4,015.3666

3.4 Building Construction - 2024

Unmitigated Construction On-Site

	ROG	NOx	CO	SO2	Fugitive PM10	Exhaust PM10	PM10 Total	Fugitive PM2.5	Exhaust PM2.5	PM2.5 Total	Bio- CO2	NBio- CO2	Total CO2	CH4	N2O	CO2e
Category	lb/day										lb/day					
Off-Road	2.8438	28.6031	36.2160	0.0564		1.3862	1.3862		1.2785	1.2785		5,412.5100	5,412.5100	1.7202		5,455.5157
Total	2.8438	28.6031	36.2160	0.0564		1.3862	1.3862		1.2785	1.2785		5,412.5100	5,412.5100	1.7202		5,455.5157

Vega SES 4 Solar Energy Storage Project - Imperial County, Summer

EMFAC Off-Model Adjustment Factors for Gasoline Light Duty Vehicle to Account for the SAFE Vehicle Rule Not Applied

3.4 Building Construction - 2024

Unmitigated Construction Off-Site

	ROG	NOx	CO	SO2	Fugitive PM10	Exhaust PM10	PM10 Total	Fugitive PM2.5	Exhaust PM2.5	PM2.5 Total	Bio- CO2	NBio- CO2	Total CO2	CH4	N2O	CO2e
Category	lb/day										lb/day					
Hauling	0.0000	0.0000	0.0000	0.0000	0.0000	0.0000	0.0000	0.0000	0.0000	0.0000		0.0000	0.0000	0.0000	0.0000	0.0000
Vendor	0.0189	0.4030	0.1231	3.0400e-003	119.2980	5.2400e-003	119.3032	11.9190	5.0100e-003	11.9240		319.8973	319.8973	8.8000e-004	0.0435	332.8703
Worker	2.3203	1.0290	16.1232	0.0350	829.1202	0.0182	829.1384	83.3236	0.0168	83.3404		3,533.3239	3,533.3239	0.1039	0.0991	3,565.4648
Total	2.3392	1.4319	16.2463	0.0380	948.4182	0.0235	948.4417	95.2426	0.0218	95.2644		3,853.2212	3,853.2212	0.1048	0.1426	3,898.3351

Mitigated Construction On-Site

	ROG	NOx	CO	SO2	Fugitive PM10	Exhaust PM10	PM10 Total	Fugitive PM2.5	Exhaust PM2.5	PM2.5 Total	Bio- CO2	NBio- CO2	Total CO2	CH4	N2O	CO2e
Category	lb/day										lb/day					
Off-Road	2.8438	28.6031	36.2160	0.0564		1.3862	1.3862		1.2785	1.2785	0.0000	5,412.5100	5,412.5100	1.7202		5,455.5157
Total	2.8438	28.6031	36.2160	0.0564		1.3862	1.3862		1.2785	1.2785	0.0000	5,412.5100	5,412.5100	1.7202		5,455.5157

Vega SES 4 Solar Energy Storage Project - Imperial County, Summer

EMFAC Off-Model Adjustment Factors for Gasoline Light Duty Vehicle to Account for the SAFE Vehicle Rule Not Applied

3.4 Building Construction - 2024

Mitigated Construction Off-Site

	ROG	NOx	CO	SO2	Fugitive PM10	Exhaust PM10	PM10 Total	Fugitive PM2.5	Exhaust PM2.5	PM2.5 Total	Bio- CO2	NBio- CO2	Total CO2	CH4	N2O	CO2e
Category	lb/day										lb/day					
Hauling	0.0000	0.0000	0.0000	0.0000	0.0000	0.0000	0.0000	0.0000	0.0000	0.0000		0.0000	0.0000	0.0000	0.0000	0.0000
Vendor	0.0189	0.4030	0.1231	3.0400e-003	11.0155	5.2400e-003	11.0208	1.1123	5.0100e-003	1.1173		319.8973	319.8973	8.8000e-004	0.0435	332.8703
Worker	2.3203	1.0290	16.1232	0.0350	79.3306	0.0182	79.3488	8.4939	0.0168	8.5107		3,533.3239	3,533.3239	0.1039	0.0991	3,565.4648
Total	2.3392	1.4319	16.2463	0.0380	90.3461	0.0235	90.3696	9.6062	0.0218	9.6280		3,853.2212	3,853.2212	0.1048	0.1426	3,898.3351

4.0 Operational Detail - Mobile

4.1 Mitigation Measures Mobile

Vega SES 4 Solar Energy Storage Project - Imperial County, Summer

EMFAC Off-Model Adjustment Factors for Gasoline Light Duty Vehicle to Account for the SAFE Vehicle Rule Not Applied

	ROG	NOx	CO	SO2	Fugitive PM10	Exhaust PM10	PM10 Total	Fugitive PM2.5	Exhaust PM2.5	PM2.5 Total	Bio- CO2	NBio- CO2	Total CO2	CH4	N2O	CO2e
Category	lb/day										lb/day					
Mitigated	0.0294	0.0355	0.3113	6.4000e-004	4.8460	4.4000e-004	4.8464	0.4922	4.1000e-004	0.4927		64.8492	64.8492	2.6500e-003	2.7400e-003	65.7319
Unmitigated	0.0294	0.0355	0.3113	6.4000e-004	4.8460	4.4000e-004	4.8464	0.4922	4.1000e-004	0.4927		64.8492	64.8492	2.6500e-003	2.7400e-003	65.7319

4.2 Trip Summary Information

Land Use	Average Daily Trip Rate			Unmitigated	Mitigated
	Weekday	Saturday	Sunday	Annual VMT	Annual VMT
Refrigerated Warehouse-No Rail	2.96	0.00	0.00	10,455	10,455
Refrigerated Warehouse-No Rail	2.96	0.00	0.00	10,455	10,455
Other Non-Asphalt Surfaces	0.00	0.00	0.00		
Other Non-Asphalt Surfaces	0.00	0.00	0.00		
Total	5.92	0.00	0.00	20,910	20,910

4.3 Trip Type Information

Land Use	Miles			Trip %			Trip Purpose %		
	H-W or C-W	H-S or C-C	H-O or C-NW	H-W or C-W	H-S or C-C	H-O or C-NW	Primary	Diverted	Pass-by
Refrigerated Warehouse-No	16.40	9.50	11.90	59.00	0.00	41.00	92	5	3
Refrigerated Warehouse-No	16.40	9.50	11.90	59.00	0.00	41.00	92	5	3
Other Non-Asphalt Surfaces	16.40	9.50	11.90	0.00	0.00	0.00	0	0	0
Other Non-Asphalt Surfaces	16.40	9.50	11.90	0.00	0.00	0.00	0	0	0

4.4 Fleet Mix

Vega SES 4 Solar Energy Storage Project - Imperial County, Summer

EMFAC Off-Model Adjustment Factors for Gasoline Light Duty Vehicle to Account for the SAFE Vehicle Rule Not Applied

Land Use	LDA	LDT1	LDT2	MDV	LHD1	LHD2	MHD	HHD	OBUS	UBUS	MCY	SBUS	MH
Refrigerated Warehouse-No Rail	0.521846	0.059402	0.180067	0.151114	0.027614	0.006908	0.008276	0.016396	0.000918	0.000121	0.022925	0.000779	0.003633
Other Non-Asphalt Surfaces	0.521846	0.059402	0.180067	0.151114	0.027614	0.006908	0.008276	0.016396	0.000918	0.000121	0.022925	0.000779	0.003633

5.0 Energy Detail

Historical Energy Use: N

5.1 Mitigation Measures Energy

Percent of Electricity Use Generated with Renewable Energy

Category	ROG	NOx	CO	SO2	Fugitive PM10	Exhaust PM10	PM10 Total	Fugitive PM2.5	Exhaust PM2.5	PM2.5 Total	Bio- CO2	NBio- CO2	Total CO2	CH4	N2O	CO2e
Category	lb/day										lb/day					
NaturalGas Mitigated	0.2663	2.4210	2.0337	0.0145		0.1840	0.1840		0.1840	0.1840		2,905.2168	2,905.2168	0.0557	0.0533	2,922.4811
NaturalGas Unmitigated	0.2663	2.4210	2.0337	0.0145		0.1840	0.1840		0.1840	0.1840		2,905.2168	2,905.2168	0.0557	0.0533	2,922.4811

Vega SES 4 Solar Energy Storage Project - Imperial County, Summer

EMFAC Off-Model Adjustment Factors for Gasoline Light Duty Vehicle to Account for the SAFE Vehicle Rule Not Applied

5.2 Energy by Land Use - NaturalGas

Unmitigated

	NaturalGas Use	ROG	NOx	CO	SO2	Fugitive PM10	Exhaust PM10	PM10 Total	Fugitive PM2.5	Exhaust PM2.5	PM2.5 Total	Bio- CO2	NBio- CO2	Total CO2	CH4	N2O	CO2e
Land Use	kBTU/yr	lb/day										lb/day					
Other Non-Asphalt Surfaces	0	0.0000	0.0000	0.0000	0.0000		0.0000	0.0000		0.0000	0.0000		0.0000	0.0000	0.0000	0.0000	0.0000
Refrigerated Warehouse-No Rail	12347.2	0.2663	2.4210	2.0337	0.0145		0.1840	0.1840		0.1840	0.1840		2,905.2168	2,905.2168	0.0557	0.0533	2,922.4811
Total		0.2663	2.4210	2.0337	0.0145		0.1840	0.1840		0.1840	0.1840		2,905.2168	2,905.2168	0.0557	0.0533	2,922.4811

Mitigated

	NaturalGas Use	ROG	NOx	CO	SO2	Fugitive PM10	Exhaust PM10	PM10 Total	Fugitive PM2.5	Exhaust PM2.5	PM2.5 Total	Bio- CO2	NBio- CO2	Total CO2	CH4	N2O	CO2e
Land Use	kBTU/yr	lb/day										lb/day					
Other Non-Asphalt Surfaces	0	0.0000	0.0000	0.0000	0.0000		0.0000	0.0000		0.0000	0.0000		0.0000	0.0000	0.0000	0.0000	0.0000
Refrigerated Warehouse-No Rail	12.3472	0.2663	2.4210	2.0337	0.0145		0.1840	0.1840		0.1840	0.1840		2,905.2168	2,905.2168	0.0557	0.0533	2,922.4811
Total		0.2663	2.4210	2.0337	0.0145		0.1840	0.1840		0.1840	0.1840		2,905.2168	2,905.2168	0.0557	0.0533	2,922.4811

6.0 Area Detail

Vega SES 4 Solar Energy Storage Project - Imperial County, Summer

EMFAC Off-Model Adjustment Factors for Gasoline Light Duty Vehicle to Account for the SAFE Vehicle Rule Not Applied

6.1 Mitigation Measures Area

	ROG	NOx	CO	SO2	Fugitive PM10	Exhaust PM10	PM10 Total	Fugitive PM2.5	Exhaust PM2.5	PM2.5 Total	Bio- CO2	NBio- CO2	Total CO2	CH4	N2O	CO2e
Category	lb/day										lb/day					
Mitigated	13.5919	5.8000e-004	0.0638	0.0000		2.3000e-004	2.3000e-004		2.3000e-004	2.3000e-004		0.1367	0.1367	3.6000e-004		0.1457
Unmitigated	13.5919	5.8000e-004	0.0638	0.0000		2.3000e-004	2.3000e-004		2.3000e-004	2.3000e-004		0.1367	0.1367	3.6000e-004		0.1457

6.2 Area by SubCategory

Unmitigated

	ROG	NOx	CO	SO2	Fugitive PM10	Exhaust PM10	PM10 Total	Fugitive PM2.5	Exhaust PM2.5	PM2.5 Total	Bio- CO2	NBio- CO2	Total CO2	CH4	N2O	CO2e
SubCategory	lb/day										lb/day					
Architectural Coating	2.9065					0.0000	0.0000		0.0000	0.0000			0.0000			0.0000
Consumer Products	10.6795					0.0000	0.0000		0.0000	0.0000			0.0000			0.0000
Landscaping	5.9100e-003	5.8000e-004	0.0638	0.0000		2.3000e-004	2.3000e-004		2.3000e-004	2.3000e-004		0.1367	0.1367	3.6000e-004		0.1457
Total	13.5919	5.8000e-004	0.0638	0.0000		2.3000e-004	2.3000e-004		2.3000e-004	2.3000e-004		0.1367	0.1367	3.6000e-004		0.1457

Vega SES 4 Solar Energy Storage Project - Imperial County, Summer

EMFAC Off-Model Adjustment Factors for Gasoline Light Duty Vehicle to Account for the SAFE Vehicle Rule Not Applied

6.2 Area by SubCategory

Mitigated

	ROG	NOx	CO	SO2	Fugitive PM10	Exhaust PM10	PM10 Total	Fugitive PM2.5	Exhaust PM2.5	PM2.5 Total	Bio- CO2	NBio- CO2	Total CO2	CH4	N2O	CO2e
SubCategory	lb/day										lb/day					
Architectural Coating	2.9065					0.0000	0.0000		0.0000	0.0000			0.0000			0.0000
Consumer Products	10.6795					0.0000	0.0000		0.0000	0.0000			0.0000			0.0000
Landscaping	5.9100e-003	5.8000e-004	0.0638	0.0000		2.3000e-004	2.3000e-004		2.3000e-004	2.3000e-004		0.1367	0.1367	3.6000e-004		0.1457
Total	13.5919	5.8000e-004	0.0638	0.0000		2.3000e-004	2.3000e-004		2.3000e-004	2.3000e-004		0.1367	0.1367	3.6000e-004		0.1457

7.0 Water Detail

7.1 Mitigation Measures Water

8.0 Waste Detail

8.1 Mitigation Measures Waste

9.0 Operational Offroad

Equipment Type	Number	Hours/Day	Days/Year	Horse Power	Load Factor	Fuel Type
Other Construction Equipment	3	8.00	8	172	0.42	Diesel
Off-Highway Trucks	1	2.00	8	402	0.38	Diesel

Vega SES 4 Solar Energy Storage Project - Imperial County, Summer

EMFAC Off-Model Adjustment Factors for Gasoline Light Duty Vehicle to Account for the SAFE Vehicle Rule Not Applied

UnMitigated/Mitigated

	ROG	NOx	CO	SO2	Fugitive PM10	Exhaust PM10	PM10 Total	Fugitive PM2.5	Exhaust PM2.5	PM2.5 Total	Bio- CO2	NBio- CO2	Total CO2	CH4	N2O	CO2e
Equipment Type	lb/day										lb/day					
Off-Highway Trucks	0.1266	0.8964	0.8262	3.3200e-003		0.0324	0.0324		0.0298	0.0298	0.0000	321.5720	321.5720	0.1040		324.1721
Other Construction Equipment	1.0338	10.2004	11.8763	0.0183		0.5310	0.5310		0.4885	0.4885	0.0000	1,775.1278	1,775.1278	0.5741		1,789.4806
Total	1.1604	11.0968	12.7025	0.0217		0.5634	0.5634		0.5184	0.5184	0.0000	2,096.6998	2,096.6998	0.6781		2,113.6527

10.0 Stationary Equipment

Fire Pumps and Emergency Generators

Equipment Type	Number	Hours/Day	Hours/Year	Horse Power	Load Factor	Fuel Type
----------------	--------	-----------	------------	-------------	-------------	-----------

Boilers

Equipment Type	Number	Heat Input/Day	Heat Input/Year	Boiler Rating	Fuel Type
----------------	--------	----------------	-----------------	---------------	-----------

User Defined Equipment

Equipment Type	Number
----------------	--------

11.0 Vegetation

Vega SES 4 Solar Energy Storage Project - Imperial County, Winter

EMFAC Off-Model Adjustment Factors for Gasoline Light Duty Vehicle to Account for the SAFE Vehicle Rule Not Applied

**Vega SES 4 Solar Energy Storage Project
Imperial County, Winter**

1.0 Project Characteristics

1.1 Land Usage

Land Uses	Size	Metric	Lot Acreage	Floor Surface Area	Population
Other Non-Asphalt Surfaces	447.00	Acre	447.00	19,471,320.00	0
Refrigerated Warehouse-No Rail	87.12	1000sqft	2.00	87,120.00	0
Refrigerated Warehouse-No Rail	87.12	1000sqft	2.00	87,120.00	0
Other Non-Asphalt Surfaces	3.50	Acre	3.50	152,460.00	0

1.2 Other Project Characteristics

Urbanization	Rural	Wind Speed (m/s)	3.4	Precipitation Freq (Days)	12
Climate Zone	15			Operational Year	2023
Utility Company	Imperial Irrigation District				
CO2 Intensity (lb/MWhr)	189.98	CH4 Intensity (lb/MWhr)	0.033	N2O Intensity (lb/MWhr)	0.004

1.3 User Entered Comments & Non-Default Data

Project Characteristics -

Land Use - Land Uses account for 447 acres of solar field, 2 acres of BESS, 2 acres of Substation, and 3.5 acres of Staging/Parking Area

Construction Phase - Construction timing per Project Applicant

Off-road Equipment - Construction equipment per Project applicant. Plate compactor = pile driver.

Off-road Equipment - Ibid

Off-road Equipment - Construction equipment per Project applicant.

Trips and VMT - Maximun 500 worker commute trips per Traffic Study. 20.25 miles added to vendor route for extended access along border.

On-road Fugitive Dust - 89% paved roads for worker commutes [1.15 m dirt roads / 10.2 m trip length default = 89% paved roads]. Traffic Study identifies worker commute routes north of Staging/Parking Area as 100% paved. 37% paved for vendor/equipment hauling trips. Trips require additional 20.25 miles of distance on dirt roadway.

PC ORIGINAL PKG

Vega SES 4 Solar Energy Storage Project - Imperial County, Winter

EMFAC Off-Model Adjustment Factors for Gasoline Light Duty Vehicle to Account for the SAFE Vehicle Rule Not Applied

Grading -

Vehicle Trips - Maximum daily trips = 6 per Traffic Study

Road Dust - 92% paved roads for operational worker commutes [1.15 m dirt roads / 14.55 m trip length default weighted average = 92% paved roads].

Energy Use - Solar facility- no operational energy use.

Water And Wastewater - Water use being kept for light industrial land use as the solar panels may need to be cleaned.

Solid Waste - No solid waste- solar facility.

Construction Off-road Equipment Mitigation - Mitigation measure AQ-1 accounted. PM Reduction value for applying soil stabilizers to unpaved roadways per communication with ICAPCD (Monica Soucier via email correspondence).

Mobile Land Use Mitigation -

Energy Mitigation -

Operational Off-Road Equipment - Onsite maintenance expected 4 times annually.

Table Name	Column Name	Default Value	New Value
tblConstDustMitigation	WaterUnpavedRoadVehicleSpeed	40	15
tblConstructionPhase	NumDays	7,750.00	286.00
tblConstructionPhase	NumDays	775.00	66.00
tblConstructionPhase	NumDays	300.00	33.00
tblConstructionPhase	PhaseEndDate	9/30/2055	7/25/2024
tblConstructionPhase	PhaseEndDate	1/15/2026	6/21/2023
tblConstructionPhase	PhaseEndDate	1/26/2023	3/21/2023
tblConstructionPhase	PhaseStartDate	1/16/2026	6/22/2023
tblConstructionPhase	PhaseStartDate	1/27/2023	3/22/2023
tblConstructionPhase	PhaseStartDate	12/3/2021	2/3/2023
tblOffRoadEquipment	LoadFactor	0.36	0.36
tblOffRoadEquipment	LoadFactor	0.40	0.40
tblOffRoadEquipment	LoadFactor	0.42	0.42
tblOffRoadEquipment	LoadFactor	0.36	0.36
tblOffRoadEquipment	LoadFactor	0.50	0.50
tblOffRoadEquipment	LoadFactor	0.38	0.38
tblOffRoadEquipment	OffRoadEquipmentType	PC ORIGINAL PKG	Rubber Tired Loaders

Vega SES 4 Solar Energy Storage Project - Imperial County, Winter

EMFAC Off-Model Adjustment Factors for Gasoline Light Duty Vehicle to Account for the SAFE Vehicle Rule Not Applied

tblOffRoadEquipment	OffRoadEquipmentType		Rough Terrain Forklifts
tblOffRoadEquipment	OffRoadEquipmentType		Pavers
tblOffRoadEquipment	OffRoadEquipmentType		Paving Equipment
tblOffRoadEquipment	OffRoadEquipmentType		Plate Compactors
tblOffRoadEquipment	OffRoadEquipmentType		Trenchers
tblOffRoadEquipment	OffRoadEquipmentType		Rollers
tblOffRoadEquipment	OffRoadEquipmentUnitAmount	2.00	4.00
tblOffRoadEquipment	OffRoadEquipmentUnitAmount	3.00	0.00
tblOffRoadEquipment	OffRoadEquipmentUnitAmount	1.00	0.00
tblOffRoadEquipment	OffRoadEquipmentUnitAmount	1.00	3.00
tblOffRoadEquipment	OffRoadEquipmentUnitAmount	1.00	2.00
tblOffRoadEquipment	OffRoadEquipmentUnitAmount	3.00	0.00
tblOffRoadEquipment	OffRoadEquipmentUnitAmount	3.00	4.00
tblOffRoadEquipment	OffRoadEquipmentUnitAmount	2.00	4.00
tblOffRoadEquipment	OffRoadEquipmentUnitAmount	4.00	2.00
tblOffRoadEquipment	OffRoadEquipmentUnitAmount	1.00	0.00
tblOnRoadDust	VendorPercentPave	50.00	37.00
tblOnRoadDust	VendorPercentPave	50.00	37.00
tblOnRoadDust	VendorPercentPave	50.00	37.00
tblOnRoadDust	WorkerPercentPave	50.00	89.00
tblOnRoadDust	WorkerPercentPave	50.00	89.00
tblOnRoadDust	WorkerPercentPave	50.00	89.00
tblOperationalOffRoadEquipment	OperDaysPerYear	260.00	8.00
tblOperationalOffRoadEquipment	OperDaysPerYear	260.00	8.00
tblOperationalOffRoadEquipment	OperHoursPerDay	8.00	2.00
tblOperationalOffRoadEquipment	OperLoadFactor	0.42	0.42
tblOperationalOffRoadEquipment	OperLoadFactor	0.38	0.38
tblOperationalOffRoadEquipment	OperOffRoadEquipmentNumber	0.00	3.00
tblOperationalOffRoadEquipment	OperOffRoadEquipmentNumber	0.00	1.00

PC ORIGINAL PKG

Vega SES 4 Solar Energy Storage Project - Imperial County, Winter

EMFAC Off-Model Adjustment Factors for Gasoline Light Duty Vehicle to Account for the SAFE Vehicle Rule Not Applied

tblProjectCharacteristics	UrbanizationLevel	Urban	Rural
tblRoadDust	RoadPercentPave	50	92
tblTripsAndVMT	VendorTripLength	11.90	32.15
tblTripsAndVMT	VendorTripLength	11.90	32.15
tblTripsAndVMT	VendorTripLength	11.90	32.15
tblTripsAndVMT	VendorTripNumber	0.00	4.00
tblTripsAndVMT	VendorTripNumber	0.00	4.00
tblTripsAndVMT	VendorTripNumber	3,245.00	4.00
tblTripsAndVMT	WorkerTripNumber	8,315.00	500.00
tblVehicleTrips	ST_TR	2.12	0.00
tblVehicleTrips	SU_TR	2.12	0.00
tblVehicleTrips	WD_TR	2.12	0.03
tblWater	IndoorWaterUseRate	40,293,000.00	3,259,000.00

2.0 Emissions Summary

Vega SES 4 Solar Energy Storage Project - Imperial County, Winter

EMFAC Off-Model Adjustment Factors for Gasoline Light Duty Vehicle to Account for the SAFE Vehicle Rule Not Applied

2.1 Overall Construction (Maximum Daily Emission)

Unmitigated Construction

	ROG	NOx	CO	SO2	Fugitive PM10	Exhaust PM10	PM10 Total	Fugitive PM2.5	Exhaust PM2.5	PM2.5 Total	Bio- CO2	NBio- CO2	Total CO2	CH4	N2O	CO2e
Year	lb/day										lb/day					
2023	5.6158	57.6586	48.8527	0.1058	948.4182	2.3569	949.9344	95.2426	2.1685	96.6408	0.0000	10,283.40 13	10,283.40 13	3.1545	0.1542	10,377.99 89
2024	4.6139	30.1241	47.8943	0.0892	948.4182	1.4097	949.8279	95.2426	1.3002	96.5428	0.0000	8,737.131 7	8,737.131 7	1.8264	0.1449	8,825.984 3
Maximum	5.6158	57.6586	48.8527	0.1058	948.4182	2.3569	949.9344	95.2426	2.1685	96.6408	0.0000	10,283.40 13	10,283.40 13	3.1545	0.1542	10,377.99 89

Mitigated Construction

	ROG	NOx	CO	SO2	Fugitive PM10	Exhaust PM10	PM10 Total	Fugitive PM2.5	Exhaust PM2.5	PM2.5 Total	Bio- CO2	NBio- CO2	Total CO2	CH4	N2O	CO2e
Year	lb/day										lb/day					
2023	5.6158	57.6586	48.8527	0.1058	90.3461	2.3569	91.8623	9.6062	2.1685	11.0044	0.0000	10,283.40 13	10,283.40 13	3.1545	0.1542	10,377.99 89
2024	4.6139	30.1241	47.8943	0.0892	90.3461	1.4097	91.7558	9.6062	1.3002	10.9064	0.0000	8,737.131 7	8,737.131 7	1.8264	0.1449	8,825.984 3
Maximum	5.6158	57.6586	48.8527	0.1058	90.3461	2.3569	91.8623	9.6062	2.1685	11.0044	0.0000	10,283.40 13	10,283.40 13	3.1545	0.1542	10,377.99 89

Vega SES 4 Solar Energy Storage Project - Imperial County, Winter

EMFAC Off-Model Adjustment Factors for Gasoline Light Duty Vehicle to Account for the SAFE Vehicle Rule Not Applied

	ROG	NOx	CO	SO2	Fugitive PM10	Exhaust PM10	PM10 Total	Fugitive PM2.5	Exhaust PM2.5	PM2.5 Total	Bio- CO2	NBio-CO2	Total CO2	CH4	N2O	CO2e
Percent Reduction	0.00	0.00	0.00	0.00	90.47	0.00	90.33	89.91	0.00	88.66	0.00	0.00	0.00	0.00	0.00	0.00

2.2 Overall Operational

Unmitigated Operational

	ROG	NOx	CO	SO2	Fugitive PM10	Exhaust PM10	PM10 Total	Fugitive PM2.5	Exhaust PM2.5	PM2.5 Total	Bio- CO2	NBio- CO2	Total CO2	CH4	N2O	CO2e
Category	lb/day										lb/day					
Area	13.5919	5.8000e-004	0.0638	0.0000		2.3000e-004	2.3000e-004		2.3000e-004	2.3000e-004		0.1367	0.1367	3.6000e-004		0.1457
Energy	0.2663	2.4210	2.0337	0.0145		0.1840	0.1840		0.1840	0.1840		2,905.2168	2,905.2168	0.0557	0.0533	2,922.4811
Mobile	0.0206	0.0393	0.2405	5.6000e-004	4.8460	4.4000e-004	4.8464	0.4922	4.1000e-004	0.4927		57.0593	57.0593	2.6600e-003	2.8300e-003	57.9690
Offroad	1.1604	11.0968	12.7025	0.0217		0.5634	0.5634		0.5184	0.5184	0.0000	2,096.6998	2,096.6998	0.6781		2,113.6527
Total	15.0393	13.5577	15.0404	0.0367	4.8460	0.7481	5.5941	0.4922	0.7030	1.1952	0.0000	5,059.1127	5,059.1127	0.7368	0.0561	5,094.2485

Vega SES 4 Solar Energy Storage Project - Imperial County, Winter

EMFAC Off-Model Adjustment Factors for Gasoline Light Duty Vehicle to Account for the SAFE Vehicle Rule Not Applied

2.2 Overall Operational

Mitigated Operational

	ROG	NOx	CO	SO2	Fugitive PM10	Exhaust PM10	PM10 Total	Fugitive PM2.5	Exhaust PM2.5	PM2.5 Total	Bio- CO2	NBio- CO2	Total CO2	CH4	N2O	CO2e
Category	lb/day										lb/day					
Area	13.5919	5.8000e-004	0.0638	0.0000		2.3000e-004	2.3000e-004		2.3000e-004	2.3000e-004		0.1367	0.1367	3.6000e-004		0.1457
Energy	0.2663	2.4210	2.0337	0.0145		0.1840	0.1840		0.1840	0.1840		2,905.2168	2,905.2168	0.0557	0.0533	2,922.4811
Mobile	0.0206	0.0393	0.2405	5.6000e-004	4.8460	4.4000e-004	4.8464	0.4922	4.1000e-004	0.4927		57.0593	57.0593	2.6600e-003	2.8300e-003	57.9690
Offroad	1.1604	11.0968	12.7025	0.0217		0.5634	0.5634		0.5184	0.5184	0.0000	2,096.6998	2,096.6998	0.6781		2,113.6527
Total	15.0393	13.5577	15.0404	0.0367	4.8460	0.7481	5.5941	0.4922	0.7030	1.1952	0.0000	5,059.1127	5,059.1127	0.7368	0.0561	5,094.2485

	ROG	NOx	CO	SO2	Fugitive PM10	Exhaust PM10	PM10 Total	Fugitive PM2.5	Exhaust PM2.5	PM2.5 Total	Bio- CO2	NBio- CO2	Total CO2	CH4	N2O	CO2e
Percent Reduction	0.00	0.00	0.00	0.00	0.00	0.00	0.00	0.00	0.00	0.00	0.00	0.00	0.00	0.00	0.00	0.00

3.0 Construction Detail

Construction Phase

Phase Number	Phase Name	Phase Type	Start Date	End Date	Num Days Week	Num Days	Phase Description
1	Site Preparation	Site Preparation	2/3/2023	3/21/2023	5	33	
2	Grading	Grading	3/22/2023	6/21/2023	5	66	
3	Building Construction	Building Construction	6/22/2023	7/25/2024	5	286	

Acres of Grading (Site Preparation Phase): 0

PC ORIGINAL PKG

Vega SES 4 Solar Energy Storage Project - Imperial County, Winter

EMFAC Off-Model Adjustment Factors for Gasoline Light Duty Vehicle to Account for the SAFE Vehicle Rule Not Applied

Acres of Grading (Grading Phase): 297

Acres of Paving: 450.5

Residential Indoor: 0; Residential Outdoor: 0; Non-Residential Indoor: 0; Non-Residential Outdoor: 0; Striped Parking Area: 0 (Architectural Coating – sqft)

OffRoad Equipment

Phase Name	Offroad Equipment Type	Amount	Usage Hours	Horse Power	Load Factor
Site Preparation	Rubber Tired Dozers	0	8.00	247	0.40
Site Preparation	Tractors/Loaders/Backhoes	2	8.00	97	0.37
Grading	Excavators	4	8.00	158	0.38
Grading	Graders	3	8.00	187	0.41
Grading	Rubber Tired Dozers	2	8.00	247	0.40
Grading	Scrapers	2	8.00	367	0.48
Grading	Tractors/Loaders/Backhoes	4	8.00	97	0.37
Building Construction	Cranes	1	7.00	231	0.29
Building Construction	Forklifts	0	8.00	89	0.20
Building Construction	Generator Sets	0	8.00	84	0.74
Site Preparation	Rubber Tired Loaders	2	8.00	203	0.36
Building Construction	Rough Terrain Forklifts	4	8.00	100	0.40
Building Construction	Pavers	1	8.00	130	0.42
Building Construction	Tractors/Loaders/Backhoes	4	7.00	97	0.37
Building Construction	Paving Equipment	2	8.00	132	0.36
Building Construction	Welders	0	8.00	46	0.45
Building Construction	Plate Compactors	4	8.00	8	0.43
Building Construction	Trenchers	2	8.00	78	0.50
Building Construction	Rollers	2	8.00	80	0.38

Trips and VMT

Vega SES 4 Solar Energy Storage Project - Imperial County, Winter

EMFAC Off-Model Adjustment Factors for Gasoline Light Duty Vehicle to Account for the SAFE Vehicle Rule Not Applied

Phase Name	Offroad Equipment Count	Worker Trip Number	Vendor Trip Number	Hauling Trip Number	Worker Trip Length	Vendor Trip Length	Hauling Trip Length	Worker Vehicle Class	Vendor Vehicle Class	Hauling Vehicle Class
Site Preparation	4	10.00	4.00	0.00	10.20	32.15	20.00	LD_Mix	HDT_Mix	HHDT
Grading	15	38.00	4.00	0.00	10.20	32.15	20.00	LD_Mix	HDT_Mix	HHDT
Building Construction	20	500.00	4.00	0.00	10.20	32.15	20.00	LD_Mix	HDT_Mix	HHDT

3.1 Mitigation Measures Construction

- Use Soil Stabilizer
- Water Exposed Area
- Water Unpaved Roads
- Reduce Vehicle Speed on Unpaved Roads

3.2 Site Preparation - 2023

Unmitigated Construction On-Site

	ROG	NOx	CO	SO2	Fugitive PM10	Exhaust PM10	PM10 Total	Fugitive PM2.5	Exhaust PM2.5	PM2.5 Total	Bio- CO2	NBio- CO2	Total CO2	CH4	N2O	CO2e
Category	lb/day										lb/day					
Fugitive Dust					0.0000	0.0000	0.0000	0.0000	0.0000	0.0000			0.0000			0.0000
Off-Road	0.8464	8.4073	7.4973	0.0188		0.3303	0.3303		0.3039	0.3039		1,820.3309	1,820.3309	0.5887		1,835.0492
Total	0.8464	8.4073	7.4973	0.0188	0.0000	0.3303	0.3303	0.0000	0.3039	0.3039		1,820.3309	1,820.3309	0.5887		1,835.0492

Vega SES 4 Solar Energy Storage Project - Imperial County, Winter

EMFAC Off-Model Adjustment Factors for Gasoline Light Duty Vehicle to Account for the SAFE Vehicle Rule Not Applied

3.2 Site Preparation - 2023

Unmitigated Construction Off-Site

	ROG	NOx	CO	SO2	Fugitive PM10	Exhaust PM10	PM10 Total	Fugitive PM2.5	Exhaust PM2.5	PM2.5 Total	Bio- CO2	NBio- CO2	Total CO2	CH4	N2O	CO2e
Category	lb/day										lb/day					
Hauling	0.0000	0.0000	0.0000	0.0000	0.0000	0.0000	0.0000	0.0000	0.0000	0.0000		0.0000	0.0000	0.0000	0.0000	0.0000
Vendor	0.0195	0.4491	0.1329	3.0900e-003	119.2980	5.2600e-003	119.3033	11.9190	5.0300e-003	11.9240		324.5098	324.5098	9.0000e-004	0.0445	337.7815
Worker	0.0376	0.0242	0.2501	6.1000e-004	16.5824	3.8000e-004	16.5828	1.6665	3.5000e-004	1.6668		61.9312	61.9312	2.3300e-003	2.1900e-003	62.6433
Total	0.0571	0.4733	0.3830	3.7000e-003	135.8804	5.6400e-003	135.8861	13.5855	5.3800e-003	13.5909		386.4410	386.4410	3.2300e-003	0.0467	400.4248

Mitigated Construction On-Site

	ROG	NOx	CO	SO2	Fugitive PM10	Exhaust PM10	PM10 Total	Fugitive PM2.5	Exhaust PM2.5	PM2.5 Total	Bio- CO2	NBio- CO2	Total CO2	CH4	N2O	CO2e
Category	lb/day										lb/day					
Fugitive Dust					0.0000	0.0000	0.0000	0.0000	0.0000	0.0000			0.0000			0.0000
Off-Road	0.8464	8.4073	7.4973	0.0188		0.3303	0.3303		0.3039	0.3039	0.0000	1,820.3309	1,820.3309	0.5887		1,835.0492
Total	0.8464	8.4073	7.4973	0.0188	0.0000	0.3303	0.3303	0.0000	0.3039	0.3039	0.0000	1,820.3309	1,820.3309	0.5887		1,835.0492

Vega SES 4 Solar Energy Storage Project - Imperial County, Winter

EMFAC Off-Model Adjustment Factors for Gasoline Light Duty Vehicle to Account for the SAFE Vehicle Rule Not Applied

3.2 Site Preparation - 2023

Mitigated Construction Off-Site

	ROG	NOx	CO	SO2	Fugitive PM10	Exhaust PM10	PM10 Total	Fugitive PM2.5	Exhaust PM2.5	PM2.5 Total	Bio- CO2	NBio- CO2	Total CO2	CH4	N2O	CO2e
Category	lb/day										lb/day					
Hauling	0.0000	0.0000	0.0000	0.0000	0.0000	0.0000	0.0000	0.0000	0.0000	0.0000		0.0000	0.0000	0.0000	0.0000	0.0000
Vendor	0.0195	0.4491	0.1329	3.0900e-003	11.0155	5.2600e-003	11.0208	1.1123	5.0300e-003	1.1173		324.5098	324.5098	9.0000e-004	0.0445	337.7815
Worker	0.0376	0.0242	0.2501	6.1000e-004	1.5866	3.8000e-004	1.5870	0.1699	3.5000e-004	0.1702		61.9312	61.9312	2.3300e-003	2.1900e-003	62.6433
Total	0.0571	0.4733	0.3830	3.7000e-003	12.6022	5.6400e-003	12.6078	1.2822	5.3800e-003	1.2876		386.4410	386.4410	3.2300e-003	0.0467	400.4248

3.3 Grading - 2023

Unmitigated Construction On-Site

	ROG	NOx	CO	SO2	Fugitive PM10	Exhaust PM10	PM10 Total	Fugitive PM2.5	Exhaust PM2.5	PM2.5 Total	Bio- CO2	NBio- CO2	Total CO2	CH4	N2O	CO2e
Category	lb/day										lb/day					
Fugitive Dust					16.8164	0.0000	16.8164	7.1358	0.0000	7.1358			0.0000			0.0000
Off-Road	5.4534	57.1174	45.5209	0.1004		2.3502	2.3502		2.1621	2.1621		9,723.5530	9,723.5530	3.1448		9,802.1729
Total	5.4534	57.1174	45.5209	0.1004	16.8164	2.3502	19.1666	7.1358	2.1621	9.2979		9,723.5530	9,723.5530	3.1448		9,802.1729

Vega SES 4 Solar Energy Storage Project - Imperial County, Winter

EMFAC Off-Model Adjustment Factors for Gasoline Light Duty Vehicle to Account for the SAFE Vehicle Rule Not Applied

3.3 Grading - 2023

Unmitigated Construction Off-Site

	ROG	NOx	CO	SO2	Fugitive PM10	Exhaust PM10	PM10 Total	Fugitive PM2.5	Exhaust PM2.5	PM2.5 Total	Bio- CO2	NBio- CO2	Total CO2	CH4	N2O	CO2e
Category	lb/day										lb/day					
Hauling	0.0000	0.0000	0.0000	0.0000	0.0000	0.0000	0.0000	0.0000	0.0000	0.0000		0.0000	0.0000	0.0000	0.0000	0.0000
Vendor	0.0195	0.4491	0.1329	3.0900e-003	119.2980	5.2600e-003	119.3033	11.9190	5.0300e-003	11.9240		324.5098	324.5098	9.0000e-004	0.0445	337.7815
Worker	0.1429	0.0921	0.9504	2.3300e-003	63.0131	1.4600e-003	63.0146	6.3326	1.3500e-003	6.3339		235.3385	235.3385	8.8400e-003	8.3400e-003	238.0445
Total	0.1624	0.5412	1.0832	5.4200e-003	182.3111	6.7200e-003	182.3179	18.2516	6.3800e-003	18.2580		559.8483	559.8483	9.7400e-003	0.0528	575.8260

Mitigated Construction On-Site

	ROG	NOx	CO	SO2	Fugitive PM10	Exhaust PM10	PM10 Total	Fugitive PM2.5	Exhaust PM2.5	PM2.5 Total	Bio- CO2	NBio- CO2	Total CO2	CH4	N2O	CO2e
Category	lb/day										lb/day					
Fugitive Dust					6.5584	0.0000	6.5584	2.7829	0.0000	2.7829			0.0000			0.0000
Off-Road	5.4534	57.1174	45.5209	0.1004		2.3502	2.3502		2.1621	2.1621	0.0000	9,723.5530	9,723.5530	3.1448		9,802.1729
Total	5.4534	57.1174	45.5209	0.1004	6.5584	2.3502	8.9086	2.7829	2.1621	4.9451	0.0000	9,723.5530	9,723.5530	3.1448		9,802.1729

Vega SES 4 Solar Energy Storage Project - Imperial County, Winter

EMFAC Off-Model Adjustment Factors for Gasoline Light Duty Vehicle to Account for the SAFE Vehicle Rule Not Applied

3.3 Grading - 2023

Mitigated Construction Off-Site

	ROG	NOx	CO	SO2	Fugitive PM10	Exhaust PM10	PM10 Total	Fugitive PM2.5	Exhaust PM2.5	PM2.5 Total	Bio- CO2	NBio- CO2	Total CO2	CH4	N2O	CO2e
Category	lb/day										lb/day					
Hauling	0.0000	0.0000	0.0000	0.0000	0.0000	0.0000	0.0000	0.0000	0.0000	0.0000		0.0000	0.0000	0.0000	0.0000	0.0000
Vendor	0.0195	0.4491	0.1329	3.0900e-003	11.0155	5.2600e-003	11.0208	1.1123	5.0300e-003	1.1173		324.5098	324.5098	9.0000e-004	0.0445	337.7815
Worker	0.1429	0.0921	0.9504	2.3300e-003	6.0291	1.4600e-003	6.0306	0.6455	1.3500e-003	0.6469		235.3385	235.3385	8.8400e-003	8.3400e-003	238.0445
Total	0.1624	0.5412	1.0832	5.4200e-003	17.0447	6.7200e-003	17.0514	1.7578	6.3800e-003	1.7642		559.8483	559.8483	9.7400e-003	0.0528	575.8260

3.4 Building Construction - 2023

Unmitigated Construction On-Site

	ROG	NOx	CO	SO2	Fugitive PM10	Exhaust PM10	PM10 Total	Fugitive PM2.5	Exhaust PM2.5	PM2.5 Total	Bio- CO2	NBio- CO2	Total CO2	CH4	N2O	CO2e
Category	lb/day										lb/day					
Off-Road	2.9498	30.0468	36.2147	0.0564		1.4917	1.4917		1.3755	1.3755		5,412.1870	5,412.1870	1.7201		5,455.1901
Total	2.9498	30.0468	36.2147	0.0564		1.4917	1.4917		1.3755	1.3755		5,412.1870	5,412.1870	1.7201		5,455.1901

Vega SES 4 Solar Energy Storage Project - Imperial County, Winter

EMFAC Off-Model Adjustment Factors for Gasoline Light Duty Vehicle to Account for the SAFE Vehicle Rule Not Applied

3.4 Building Construction - 2023

Unmitigated Construction Off-Site

	ROG	NOx	CO	SO2	Fugitive PM10	Exhaust PM10	PM10 Total	Fugitive PM2.5	Exhaust PM2.5	PM2.5 Total	Bio- CO2	NBio- CO2	Total CO2	CH4	N2O	CO2e
Category	lb/day										lb/day					
Hauling	0.0000	0.0000	0.0000	0.0000	0.0000	0.0000	0.0000	0.0000	0.0000	0.0000		0.0000	0.0000	0.0000	0.0000	0.0000
Vendor	0.0195	0.4491	0.1329	3.0900e-003	119.2980	5.2600e-003	119.3033	11.9190	5.0300e-003	11.9240		324.5098	324.5098	9.0000e-004	0.0445	337.7815
Worker	1.8807	1.2119	12.5052	0.0306	829.1202	0.0192	829.1395	83.3236	0.0177	83.3413		3,096.5589	3,096.5589	0.1163	0.1097	3,132.1648
Total	1.9002	1.6610	12.6380	0.0337	948.4182	0.0245	948.4427	95.2426	0.0227	95.2653		3,421.0687	3,421.0687	0.1172	0.1542	3,469.9463

Mitigated Construction On-Site

	ROG	NOx	CO	SO2	Fugitive PM10	Exhaust PM10	PM10 Total	Fugitive PM2.5	Exhaust PM2.5	PM2.5 Total	Bio- CO2	NBio- CO2	Total CO2	CH4	N2O	CO2e
Category	lb/day										lb/day					
Off-Road	2.9498	30.0468	36.2147	0.0564		1.4917	1.4917		1.3755	1.3755	0.0000	5,412.1870	5,412.1870	1.7201		5,455.1901
Total	2.9498	30.0468	36.2147	0.0564		1.4917	1.4917		1.3755	1.3755	0.0000	5,412.1870	5,412.1870	1.7201		5,455.1901

Vega SES 4 Solar Energy Storage Project - Imperial County, Winter

EMFAC Off-Model Adjustment Factors for Gasoline Light Duty Vehicle to Account for the SAFE Vehicle Rule Not Applied

3.4 Building Construction - 2023

Mitigated Construction Off-Site

	ROG	NOx	CO	SO2	Fugitive PM10	Exhaust PM10	PM10 Total	Fugitive PM2.5	Exhaust PM2.5	PM2.5 Total	Bio- CO2	NBio- CO2	Total CO2	CH4	N2O	CO2e
Category	lb/day										lb/day					
Hauling	0.0000	0.0000	0.0000	0.0000	0.0000	0.0000	0.0000	0.0000	0.0000	0.0000		0.0000	0.0000	0.0000	0.0000	0.0000
Vendor	0.0195	0.4491	0.1329	3.0900e-003	11.0155	5.2600e-003	11.0208	1.1123	5.0300e-003	1.1173		324.5098	324.5098	9.0000e-004	0.0445	337.7815
Worker	1.8807	1.2119	12.5052	0.0306	79.3306	0.0192	79.3498	8.4939	0.0177	8.5116		3,096.5589	3,096.5589	0.1163	0.1097	3,132.1648
Total	1.9002	1.6610	12.6380	0.0337	90.3461	0.0245	90.3706	9.6062	0.0227	9.6289		3,421.0687	3,421.0687	0.1172	0.1542	3,469.9463

3.4 Building Construction - 2024

Unmitigated Construction On-Site

	ROG	NOx	CO	SO2	Fugitive PM10	Exhaust PM10	PM10 Total	Fugitive PM2.5	Exhaust PM2.5	PM2.5 Total	Bio- CO2	NBio- CO2	Total CO2	CH4	N2O	CO2e
Category	lb/day										lb/day					
Off-Road	2.8438	28.6031	36.2160	0.0564		1.3862	1.3862		1.2785	1.2785		5,412.5100	5,412.5100	1.7202		5,455.5157
Total	2.8438	28.6031	36.2160	0.0564		1.3862	1.3862		1.2785	1.2785		5,412.5100	5,412.5100	1.7202		5,455.5157

Vega SES 4 Solar Energy Storage Project - Imperial County, Winter

EMFAC Off-Model Adjustment Factors for Gasoline Light Duty Vehicle to Account for the SAFE Vehicle Rule Not Applied

3.4 Building Construction - 2024

Unmitigated Construction Off-Site

	ROG	NOx	CO	SO2	Fugitive PM10	Exhaust PM10	PM10 Total	Fugitive PM2.5	Exhaust PM2.5	PM2.5 Total	Bio- CO2	NBio- CO2	Total CO2	CH4	N2O	CO2e
Category	lb/day										lb/day					
Hauling	0.0000	0.0000	0.0000	0.0000	0.0000	0.0000	0.0000	0.0000	0.0000	0.0000		0.0000	0.0000	0.0000	0.0000	0.0000
Vendor	0.0185	0.4471	0.1245	3.0400e-003	119.2980	5.2400e-003	119.3032	11.9190	5.0200e-003	11.9240		320.1130	320.1130	8.5000e-004	0.0436	333.1296
Worker	1.7515	1.0739	11.5538	0.0297	829.1202	0.0182	829.1384	83.3236	0.0168	83.3404		3,004.5087	3,004.5087	0.1053	0.1013	3,037.3390
Total	1.7700	1.5211	11.6783	0.0328	948.4182	0.0235	948.4417	95.2426	0.0218	95.2644		3,324.6217	3,324.6217	0.1062	0.1449	3,370.4686

Mitigated Construction On-Site

	ROG	NOx	CO	SO2	Fugitive PM10	Exhaust PM10	PM10 Total	Fugitive PM2.5	Exhaust PM2.5	PM2.5 Total	Bio- CO2	NBio- CO2	Total CO2	CH4	N2O	CO2e
Category	lb/day										lb/day					
Off-Road	2.8438	28.6031	36.2160	0.0564		1.3862	1.3862		1.2785	1.2785	0.0000	5,412.5100	5,412.5100	1.7202		5,455.5157
Total	2.8438	28.6031	36.2160	0.0564		1.3862	1.3862		1.2785	1.2785	0.0000	5,412.5100	5,412.5100	1.7202		5,455.5157

Vega SES 4 Solar Energy Storage Project - Imperial County, Winter

EMFAC Off-Model Adjustment Factors for Gasoline Light Duty Vehicle to Account for the SAFE Vehicle Rule Not Applied

3.4 Building Construction - 2024

Mitigated Construction Off-Site

	ROG	NOx	CO	SO2	Fugitive PM10	Exhaust PM10	PM10 Total	Fugitive PM2.5	Exhaust PM2.5	PM2.5 Total	Bio- CO2	NBio- CO2	Total CO2	CH4	N2O	CO2e
Category	lb/day										lb/day					
Hauling	0.0000	0.0000	0.0000	0.0000	0.0000	0.0000	0.0000	0.0000	0.0000	0.0000		0.0000	0.0000	0.0000	0.0000	0.0000
Vendor	0.0185	0.4471	0.1245	3.0400e-003	11.0155	5.2400e-003	11.0208	1.1123	5.0200e-003	1.1173		320.1130	320.1130	8.5000e-004	0.0436	333.1296
Worker	1.7515	1.0739	11.5538	0.0297	79.3306	0.0182	79.3488	8.4939	0.0168	8.5107		3,004.5087	3,004.5087	0.1053	0.1013	3,037.3390
Total	1.7700	1.5211	11.6783	0.0328	90.3461	0.0235	90.3696	9.6062	0.0218	9.6280		3,324.6217	3,324.6217	0.1062	0.1449	3,370.4686

4.0 Operational Detail - Mobile

4.1 Mitigation Measures Mobile

Vega SES 4 Solar Energy Storage Project - Imperial County, Winter

EMFAC Off-Model Adjustment Factors for Gasoline Light Duty Vehicle to Account for the SAFE Vehicle Rule Not Applied

	ROG	NOx	CO	SO2	Fugitive PM10	Exhaust PM10	PM10 Total	Fugitive PM2.5	Exhaust PM2.5	PM2.5 Total	Bio- CO2	NBio- CO2	Total CO2	CH4	N2O	CO2e
Category	lb/day										lb/day					
Mitigated	0.0206	0.0393	0.2405	5.6000e-004	4.8460	4.4000e-004	4.8464	0.4922	4.1000e-004	0.4927		57.0593	57.0593	2.6600e-003	2.8300e-003	57.9690
Unmitigated	0.0206	0.0393	0.2405	5.6000e-004	4.8460	4.4000e-004	4.8464	0.4922	4.1000e-004	0.4927		57.0593	57.0593	2.6600e-003	2.8300e-003	57.9690

4.2 Trip Summary Information

Land Use	Average Daily Trip Rate			Unmitigated	Mitigated
	Weekday	Saturday	Sunday	Annual VMT	Annual VMT
Refrigerated Warehouse-No Rail	2.96	0.00	0.00	10,455	10,455
Refrigerated Warehouse-No Rail	2.96	0.00	0.00	10,455	10,455
Other Non-Asphalt Surfaces	0.00	0.00	0.00		
Other Non-Asphalt Surfaces	0.00	0.00	0.00		
Total	5.92	0.00	0.00	20,910	20,910

4.3 Trip Type Information

Land Use	Miles			Trip %			Trip Purpose %		
	H-W or C-W	H-S or C-C	H-O or C-NW	H-W or C-W	H-S or C-C	H-O or C-NW	Primary	Diverted	Pass-by
Refrigerated Warehouse-No	16.40	9.50	11.90	59.00	0.00	41.00	92	5	3
Refrigerated Warehouse-No	16.40	9.50	11.90	59.00	0.00	41.00	92	5	3
Other Non-Asphalt Surfaces	16.40	9.50	11.90	0.00	0.00	0.00	0	0	0
Other Non-Asphalt Surfaces	16.40	9.50	11.90	0.00	0.00	0.00	0	0	0

4.4 Fleet Mix

Vega SES 4 Solar Energy Storage Project - Imperial County, Winter

EMFAC Off-Model Adjustment Factors for Gasoline Light Duty Vehicle to Account for the SAFE Vehicle Rule Not Applied

Land Use	LDA	LDT1	LDT2	MDV	LHD1	LHD2	MHD	HHD	OBUS	UBUS	MCY	SBUS	MH
Refrigerated Warehouse-No Rail	0.521846	0.059402	0.180067	0.151114	0.027614	0.006908	0.008276	0.016396	0.000918	0.000121	0.022925	0.000779	0.003633
Other Non-Asphalt Surfaces	0.521846	0.059402	0.180067	0.151114	0.027614	0.006908	0.008276	0.016396	0.000918	0.000121	0.022925	0.000779	0.003633

5.0 Energy Detail

Historical Energy Use: N

5.1 Mitigation Measures Energy

Percent of Electricity Use Generated with Renewable Energy

	ROG	NOx	CO	SO2	Fugitive PM10	Exhaust PM10	PM10 Total	Fugitive PM2.5	Exhaust PM2.5	PM2.5 Total	Bio- CO2	NBio- CO2	Total CO2	CH4	N2O	CO2e
Category	lb/day										lb/day					
NaturalGas Mitigated	0.2663	2.4210	2.0337	0.0145		0.1840	0.1840		0.1840	0.1840		2,905.2168	2,905.2168	0.0557	0.0533	2,922.4811
NaturalGas Unmitigated	0.2663	2.4210	2.0337	0.0145		0.1840	0.1840		0.1840	0.1840		2,905.2168	2,905.2168	0.0557	0.0533	2,922.4811

Vega SES 4 Solar Energy Storage Project - Imperial County, Winter

EMFAC Off-Model Adjustment Factors for Gasoline Light Duty Vehicle to Account for the SAFE Vehicle Rule Not Applied

5.2 Energy by Land Use - NaturalGas

Unmitigated

	NaturalGas Use	ROG	NOx	CO	SO2	Fugitive PM10	Exhaust PM10	PM10 Total	Fugitive PM2.5	Exhaust PM2.5	PM2.5 Total	Bio- CO2	NBio- CO2	Total CO2	CH4	N2O	CO2e
Land Use	kBTU/yr	lb/day										lb/day					
Other Non-Asphalt Surfaces	0	0.0000	0.0000	0.0000	0.0000		0.0000	0.0000		0.0000	0.0000		0.0000	0.0000	0.0000	0.0000	0.0000
Refrigerated Warehouse-No Rail	12347.2	0.2663	2.4210	2.0337	0.0145		0.1840	0.1840		0.1840	0.1840		2,905.2168	2,905.2168	0.0557	0.0533	2,922.4811
Total		0.2663	2.4210	2.0337	0.0145		0.1840	0.1840		0.1840	0.1840		2,905.2168	2,905.2168	0.0557	0.0533	2,922.4811

Mitigated

	NaturalGas Use	ROG	NOx	CO	SO2	Fugitive PM10	Exhaust PM10	PM10 Total	Fugitive PM2.5	Exhaust PM2.5	PM2.5 Total	Bio- CO2	NBio- CO2	Total CO2	CH4	N2O	CO2e
Land Use	kBTU/yr	lb/day										lb/day					
Other Non-Asphalt Surfaces	0	0.0000	0.0000	0.0000	0.0000		0.0000	0.0000		0.0000	0.0000		0.0000	0.0000	0.0000	0.0000	0.0000
Refrigerated Warehouse-No Rail	12.3472	0.2663	2.4210	2.0337	0.0145		0.1840	0.1840		0.1840	0.1840		2,905.2168	2,905.2168	0.0557	0.0533	2,922.4811
Total		0.2663	2.4210	2.0337	0.0145		0.1840	0.1840		0.1840	0.1840		2,905.2168	2,905.2168	0.0557	0.0533	2,922.4811

6.0 Area Detail

Vega SES 4 Solar Energy Storage Project - Imperial County, Winter

EMFAC Off-Model Adjustment Factors for Gasoline Light Duty Vehicle to Account for the SAFE Vehicle Rule Not Applied

6.1 Mitigation Measures Area

	ROG	NOx	CO	SO2	Fugitive PM10	Exhaust PM10	PM10 Total	Fugitive PM2.5	Exhaust PM2.5	PM2.5 Total	Bio- CO2	NBio- CO2	Total CO2	CH4	N2O	CO2e
Category	lb/day										lb/day					
Mitigated	13.5919	5.8000e-004	0.0638	0.0000		2.3000e-004	2.3000e-004		2.3000e-004	2.3000e-004		0.1367	0.1367	3.6000e-004		0.1457
Unmitigated	13.5919	5.8000e-004	0.0638	0.0000		2.3000e-004	2.3000e-004		2.3000e-004	2.3000e-004		0.1367	0.1367	3.6000e-004		0.1457

6.2 Area by SubCategory

Unmitigated

	ROG	NOx	CO	SO2	Fugitive PM10	Exhaust PM10	PM10 Total	Fugitive PM2.5	Exhaust PM2.5	PM2.5 Total	Bio- CO2	NBio- CO2	Total CO2	CH4	N2O	CO2e
SubCategory	lb/day										lb/day					
Architectural Coating	2.9065					0.0000	0.0000		0.0000	0.0000			0.0000			0.0000
Consumer Products	10.6795					0.0000	0.0000		0.0000	0.0000			0.0000			0.0000
Landscaping	5.9100e-003	5.8000e-004	0.0638	0.0000		2.3000e-004	2.3000e-004		2.3000e-004	2.3000e-004		0.1367	0.1367	3.6000e-004		0.1457
Total	13.5919	5.8000e-004	0.0638	0.0000		2.3000e-004	2.3000e-004		2.3000e-004	2.3000e-004		0.1367	0.1367	3.6000e-004		0.1457

Vega SES 4 Solar Energy Storage Project - Imperial County, Winter

EMFAC Off-Model Adjustment Factors for Gasoline Light Duty Vehicle to Account for the SAFE Vehicle Rule Not Applied

6.2 Area by SubCategory

Mitigated

	ROG	NOx	CO	SO2	Fugitive PM10	Exhaust PM10	PM10 Total	Fugitive PM2.5	Exhaust PM2.5	PM2.5 Total	Bio- CO2	NBio- CO2	Total CO2	CH4	N2O	CO2e
SubCategory	lb/day										lb/day					
Architectural Coating	2.9065					0.0000	0.0000		0.0000	0.0000			0.0000			0.0000
Consumer Products	10.6795					0.0000	0.0000		0.0000	0.0000			0.0000			0.0000
Landscaping	5.9100e-003	5.8000e-004	0.0638	0.0000		2.3000e-004	2.3000e-004		2.3000e-004	2.3000e-004		0.1367	0.1367	3.6000e-004		0.1457
Total	13.5919	5.8000e-004	0.0638	0.0000		2.3000e-004	2.3000e-004		2.3000e-004	2.3000e-004		0.1367	0.1367	3.6000e-004		0.1457

7.0 Water Detail

7.1 Mitigation Measures Water

8.0 Waste Detail

8.1 Mitigation Measures Waste

9.0 Operational Offroad

Equipment Type	Number	Hours/Day	Days/Year	Horse Power	Load Factor	Fuel Type
Other Construction Equipment	3	8.00	8	172	0.42	Diesel
Off-Highway Trucks	1	2.00	8	402	0.38	Diesel

Vega SES 4 Solar Energy Storage Project - Imperial County, Winter

EMFAC Off-Model Adjustment Factors for Gasoline Light Duty Vehicle to Account for the SAFE Vehicle Rule Not Applied

UnMitigated/Mitigated

	ROG	NOx	CO	SO2	Fugitive PM10	Exhaust PM10	PM10 Total	Fugitive PM2.5	Exhaust PM2.5	PM2.5 Total	Bio- CO2	NBio- CO2	Total CO2	CH4	N2O	CO2e
Equipment Type	lb/day										lb/day					
Off-Highway Trucks	0.1266	0.8964	0.8262	3.3200e-003		0.0324	0.0324		0.0298	0.0298	0.0000	321.5720	321.5720	0.1040		324.1721
Other Construction Equipment	1.0338	10.2004	11.8763	0.0183		0.5310	0.5310		0.4885	0.4885	0.0000	1,775.1278	1,775.1278	0.5741		1,789.4806
Total	1.1604	11.0968	12.7025	0.0217		0.5634	0.5634		0.5184	0.5184	0.0000	2,096.6998	2,096.6998	0.6781		2,113.6527

10.0 Stationary Equipment

Fire Pumps and Emergency Generators

Equipment Type	Number	Hours/Day	Hours/Year	Horse Power	Load Factor	Fuel Type
----------------	--------	-----------	------------	-------------	-------------	-----------

Boilers

Equipment Type	Number	Heat Input/Day	Heat Input/Year	Boiler Rating	Fuel Type
----------------	--------	----------------	-----------------	---------------	-----------

User Defined Equipment

Equipment Type	Number
----------------	--------

11.0 Vegetation

Renewable Energy Emissions Displacement

CRITERIA AIR POLLUTANT DISPLACEMENT

PC ORIGINAL PKG

Table A-1. Renewable Energy Generator Specifications

Megawatt Project	100
Operational Time ¹	25
Annual Hours of Generation ¹	2,190
Annual Kilowatt Hours	219,000,000
Heat Rate ²	9,313
Btu Displaced ³	2,039,547,000,000

Notes:

¹ The Project is assumed to generate electricity 25 percent of the time available (2,190 hours annually).

² Heat Rate indicate the energy generator efficiency of existing fossil-fuel based energy generators. The heat rate of a power plant measures the amount of fuel used to generate one unit of electricity. Power plants with lower heat rates are more efficient than plants with higher heat rates. The CEC's "Updated Thermal Power Plant Efficiency Measures and Operational Characteristics for Production Cost Modeling" (2019) estimates heat rates and operating ranges for thermal power plants supplying energy to California. the average heat rate of power plant types are as follows:

Table A-2. Heat Rates

Steam Boiler Fueled by Coal:	10,800
Steam Boiler Fueled by Natural Gas:	10,200
Gas Turbine:	10,100
Combined Natural Gas Boiler & Turbine:	7,640

Omitting steam boilers fueled by coal since so little of California's energy is derived from coal, the average heat rate =

9313

³ The annual kilowatt hours multiplied by the average heat rate of existing fossil fuel based energy generators equals the amount of Btu displaced from fossil fuel production, as shown in Table A-3.

Table A-3. Btu Displacement

Annual Kilowatt Hours	219,000,000
Average Heat Rate	9,313
Btu Displaced from Fossil Fuel Based Energy Production	2,039,547,000,000

Energy consumption in California is predominately derived from natural gas, followed by renewables, nuclear, unspecified nonrenewable sources, and coal, as shown in Table A-4.

Table A-4. California Energy Mix (percentages)

Natural Gas	37.06
Coal	2.74
Renewables (not including hydroelectric generators)	33.09
Nuclear	9.33
Unspecified nonrenewable sources	5.36

Source: California Energy Commission. 2021. "2020 Total System Electric Generation." <https://www.energy.ca.gov/data-reports/energy-almanac/california-electricity-data/2020-total-system-electric-generation>

For the purposes of this analysis, the percentage of California energy derived from natural gas is added to unspecified nonrenewable sources. Table A-5 identifies the displaced Btu attributable to displaced natural gas and displaced coal.

Table A-5. Btu Displacement by Fossil Fuel Type - Annually

Natural Gas & Unspecified Nonrenewable Sources	865,175,837,400
Coal	55,883,587,800

The heat content of coal is assumed at 24 million Btu per ton of coal burned. Table A-6 shows the tons of displaced burned coal based on this heat content.

Table A-6. Tons of Displaced Burned Coal - Annually

Displaced Coal Burn	2,328
---------------------	-------

Table A-7. Emissions Displacement - Tons per Year⁴

Natural Gas	
Nitrogen Oxide	2.14
Carbon Monoxide	0.65
Coarse Particulate Matter	2.03
Fine Particulate Matter	0.82
Sulfur Dioxide	1.47

Coal	
Nitrogen Oxide	13.97
Carbon Monoxide	0.58
Coarse Particulate Matter	0.10
Fine Particulate Matter	0.07
Sulfur Dioxide	0.66

Table A-8. Total Combined Emissions Displacement - Tons per Year

Natural Gas & Coal	
Nitrogen Oxide	16.11
Carbon Monoxide	1.23
Coarse Particulate Matter	2.13
Fine Particulate Matter	0.89
Sulfur Dioxide	2.13

Table A-9. Total Combined Emissions Displacement over the Life of the Project (30 years) - Tons per Year

Natural Gas & Coal	
Nitrogen Oxide	483.37
Carbon Monoxide	36.93
Coarse Particulate Matter	63.93
Fine Particulate Matter	26.75
Sulfur Dioxide	64.03

⁴Source: Displaced emissions calculated by ECORP Consulting using U.S. EPA's AP-42 Fifth Edition Compilation of Air Emissions Factors 1995; 2015.

GREENHOUSE GAS EMISSIONS DISPLACEMENT

PC ORIGINAL PKG

Table B-1. Renewable Energy Generator Specifications

Megawatt Project	100
Operational Time ¹	25
Annual Hours of Generation ¹	2,190
Annual Kilowatt Hours	219,000,000
Heat Rate ²	9,313
Btu Displaced ³	2,039,547,000,000

Notes:

¹ The Project is assumed to generate electricity 25 percent of the time available (2,190 hours annually).

² Heat Rate indicate the energy generator efficiency of existing fossil-fuel based energy generators. The heat rate of a power plant measures the amount of fuel used to generate one unit of electricity. Power plants with lower heat rates are more efficient than plants with higher heat rates. The CEC's "Updated Thermal Power Plant Efficiency Measures and Operational Characteristics for Production Cost Modeling" (2019) estimates heat rates and operating ranges for thermal power plants supplying energy to California. the average heat rate of power plant types are as follows:

Table B-2. Heat Rates

Steam Boiler Fueled by Coal:	10,800
Steam Boiler Fueled by Natural Gas:	10,200
Gas Turbine:	10,100
Combined Natural Gas Boiler & Turbine:	7,640

Omitting steam boilers fueled by coal since so little of California's energy is derived from coal, the average heat rate =

9313

³ The annual kilowatt hours multiplied by the average heat rate of existing fossil fuel based energy generators equals the amount of Btu displaced from fossil fuel production, as shown in Table A-3.

Table B-3. Btu Displacement

Annual Kilowatt Hours	219,000,000
Average Heat Rate	9,313
Btu Displaced from Fossil Fuel Based Energy Production	2,039,547,000,000

Energy consumption in California is predominately derived from natural gas, followed by renewables, nuclear, unspecified nonrenewable sources, and coal, as shown in Table A-4.

Table B-4. California Energy Mix (percentages)

Natural Gas	37.06
Coal	2.74
Renewables (not including hydroelectric generators)	33.09
Nuclear	9.33
Unspecified nonrenewable sources	5.36

Source: California Energy Commission. 2021. "2020 Total System Electric Generation." <https://www.energy.ca.gov/data-reports/energy-almanac/california-electricity-data/2020-total-system-electric-generation>

For the purposes of this analysis, the percentage of California energy derived from natural gas is added to unspecified nonrenewable sources. Table A-5 identifies the displaced Btu attributable to displaced natural gas and displaced coal.

Table B-5. Btu Displacement by Fossil Fuel Type - Annually

Natural Gas & Unspecified Nonrenewable Sources	865,175,837,400
Coal	55,883,587,800

The heat content of coal is assumed at 24 million Btu per ton of coal burned. Table A-6 shows the tons of displaced burned coal based on this heat content.

Table B-6. Tons of Displaced Burned Coal - Annually

Displaced Coal Burn	2,328
---------------------	-------

Table B-7. Emissions Displacement - Metric Tons per Year⁴

Natural Gas	
Carbon Dioxide	47,585
Methane	0.000
Nitrous Oxide	0.000
Carbon Dioxide Equivalents	47,585

Coal	
Carbon Dioxide	5626
Methane	0.037
Nitrous Oxide	0.028
Carbon Dioxide Equivalents	5635

Table B-8. Total Combined Emissions Displacement - Metric Tons per Year

Natural Gas & Coal	
Carbon Dioxide	53,210
Methane	0.037
Nitrous Oxide	0.028
Carbon Dioxide Equivalents	53,220

Table B-9. Total Combined Emissions Displacement over the Life of the Project (30 years) - Metric Tons per Year

Natural Gas & Coal	
Carbon Dioxide	1,596,309
Methane	1.118
Nitrous Oxide	0.838
Carbon Dioxide Equivalents	1,596,596

⁴Source: Displaced emissions calculated by ECORP Consulting using U.S. EPA's AP-42 Fifth Edition Compilation of Air Emissions Factors 1995; 2015.

Attachment C – CalEEMod Output Files Greenhouse Gas Emissions

Vega SES 4 Solar Energy Storage Project - Imperial County, Annual

EMFAC Off-Model Adjustment Factors for Gasoline Light Duty Vehicle to Account for the SAFE Vehicle Rule Not Applied

**Vega SES 4 Solar Energy Storage Project
Imperial County, Annual**

1.0 Project Characteristics

1.1 Land Usage

Land Uses	Size	Metric	Lot Acreage	Floor Surface Area	Population
Other Non-Asphalt Surfaces	447.00	Acre	447.00	19,471,320.00	0
Refrigerated Warehouse-No Rail	87.12	1000sqft	2.00	87,120.00	0
Refrigerated Warehouse-No Rail	87.12	1000sqft	2.00	87,120.00	0
Other Non-Asphalt Surfaces	3.50	Acre	3.50	152,460.00	0

1.2 Other Project Characteristics

Urbanization	Rural	Wind Speed (m/s)	3.4	Precipitation Freq (Days)	12
Climate Zone	15			Operational Year	2023
Utility Company	Imperial Irrigation District				
CO2 Intensity (lb/MWhr)	189.98	CH4 Intensity (lb/MWhr)	0.033	N2O Intensity (lb/MWhr)	0.004

1.3 User Entered Comments & Non-Default Data

Project Characteristics -

Land Use - Land Uses account for 447 acres of solar field, 2 acres of BESS, 2 acres of Substation, and 3.5 acres of Staging/Parking Area

Construction Phase - Construction timing per Project Applicant

Off-road Equipment - Construction equipment per Project applicant. Plate compactor = pile driver.

Off-road Equipment - Ibid

Off-road Equipment - Construction equipment per Project applicant.

Trips and VMT - Maximun 500 worker commute trips per Traffic Study. 20.25 miles added to vendor route for extended access along border.

On-road Fugitive Dust - 89% paved roads for worker commutes [1.15 m dirt roads / 10.2 m trip length default = 89% paved roads]. Traffic Study identifies worker commute routes north of Staging/Parking Area as 100% paved. 37% paved for vendor/equipment hauling trips. Trips require additional 20.25 miles of distance on dirt roadway.

PC ORIGINAL PKG

Vega SES 4 Solar Energy Storage Project - Imperial County, Annual

EMFAC Off-Model Adjustment Factors for Gasoline Light Duty Vehicle to Account for the SAFE Vehicle Rule Not Applied

Grading -

Vehicle Trips - Maximum daily trips = 6 per Traffic Study

Road Dust - 92% paved roads for operational worker commutes [1.15 m dirt roads / 14.55 m trip length default weighted average = 92% paved roads].

Energy Use - Solar facility- no operational energy use.

Water And Wastewater - Water use being kept for light industrial land use as the solar panels may need to be cleaned.

Solid Waste - No solid waste- solar facility.

Construction Off-road Equipment Mitigation - Mitigation measure AQ-1 accounted. PM Reduction value for applying soil stabilizers to unpaved roadways per communication with ICAPCD (Monica Soucier via email correspondence).

Mobile Land Use Mitigation -

Energy Mitigation -

Operational Off-Road Equipment - Onsite maintenance expected 4 times annually.

Table Name	Column Name	Default Value	New Value
tblConstDustMitigation	WaterUnpavedRoadVehicleSpeed	40	15
tblConstructionPhase	NumDays	7,750.00	286.00
tblConstructionPhase	NumDays	775.00	66.00
tblConstructionPhase	NumDays	300.00	33.00
tblConstructionPhase	PhaseEndDate	9/30/2055	7/25/2024
tblConstructionPhase	PhaseEndDate	1/15/2026	6/21/2023
tblConstructionPhase	PhaseEndDate	1/26/2023	3/21/2023
tblConstructionPhase	PhaseStartDate	1/16/2026	6/22/2023
tblConstructionPhase	PhaseStartDate	1/27/2023	3/22/2023
tblConstructionPhase	PhaseStartDate	12/3/2021	2/3/2023
tblOffRoadEquipment	LoadFactor	0.36	0.36
tblOffRoadEquipment	LoadFactor	0.40	0.40
tblOffRoadEquipment	LoadFactor	0.42	0.42
tblOffRoadEquipment	LoadFactor	0.36	0.36
tblOffRoadEquipment	LoadFactor	0.50	0.50
tblOffRoadEquipment	LoadFactor	0.38	0.38
tblOffRoadEquipment	OffRoadEquipmentType	PC ORIGINAL PKG	Rubber Tired Loaders

Vega SES 4 Solar Energy Storage Project - Imperial County, Annual

EMFAC Off-Model Adjustment Factors for Gasoline Light Duty Vehicle to Account for the SAFE Vehicle Rule Not Applied

tblOffRoadEquipment	OffRoadEquipmentType		Rough Terrain Forklifts
tblOffRoadEquipment	OffRoadEquipmentType		Pavers
tblOffRoadEquipment	OffRoadEquipmentType		Paving Equipment
tblOffRoadEquipment	OffRoadEquipmentType		Plate Compactors
tblOffRoadEquipment	OffRoadEquipmentType		Trenchers
tblOffRoadEquipment	OffRoadEquipmentType		Rollers
tblOffRoadEquipment	OffRoadEquipmentUnitAmount	2.00	4.00
tblOffRoadEquipment	OffRoadEquipmentUnitAmount	3.00	0.00
tblOffRoadEquipment	OffRoadEquipmentUnitAmount	1.00	0.00
tblOffRoadEquipment	OffRoadEquipmentUnitAmount	1.00	3.00
tblOffRoadEquipment	OffRoadEquipmentUnitAmount	1.00	2.00
tblOffRoadEquipment	OffRoadEquipmentUnitAmount	3.00	0.00
tblOffRoadEquipment	OffRoadEquipmentUnitAmount	3.00	4.00
tblOffRoadEquipment	OffRoadEquipmentUnitAmount	2.00	4.00
tblOffRoadEquipment	OffRoadEquipmentUnitAmount	4.00	2.00
tblOffRoadEquipment	OffRoadEquipmentUnitAmount	1.00	0.00
tblOnRoadDust	VendorPercentPave	50.00	37.00
tblOnRoadDust	VendorPercentPave	50.00	37.00
tblOnRoadDust	VendorPercentPave	50.00	37.00
tblOnRoadDust	WorkerPercentPave	50.00	89.00
tblOnRoadDust	WorkerPercentPave	50.00	89.00
tblOnRoadDust	WorkerPercentPave	50.00	89.00
tblOperationalOffRoadEquipment	OperDaysPerYear	260.00	8.00
tblOperationalOffRoadEquipment	OperDaysPerYear	260.00	8.00
tblOperationalOffRoadEquipment	OperHoursPerDay	8.00	2.00
tblOperationalOffRoadEquipment	OperLoadFactor	0.42	0.42
tblOperationalOffRoadEquipment	OperLoadFactor	0.38	0.38
tblOperationalOffRoadEquipment	OperOffRoadEquipmentNumber	0.00	3.00
tblOperationalOffRoadEquipment	OperOffRoadEquipmentNumber	0.00	1.00

PC ORIGINAL PKG

Vega SES 4 Solar Energy Storage Project - Imperial County, Annual

EMFAC Off-Model Adjustment Factors for Gasoline Light Duty Vehicle to Account for the SAFE Vehicle Rule Not Applied

tblProjectCharacteristics	UrbanizationLevel	Urban	Rural
tblRoadDust	RoadPercentPave	50	92
tblTripsAndVMT	VendorTripLength	11.90	32.15
tblTripsAndVMT	VendorTripLength	11.90	32.15
tblTripsAndVMT	VendorTripLength	11.90	32.15
tblTripsAndVMT	VendorTripNumber	0.00	4.00
tblTripsAndVMT	VendorTripNumber	0.00	4.00
tblTripsAndVMT	VendorTripNumber	3,245.00	4.00
tblTripsAndVMT	WorkerTripNumber	8,315.00	500.00
tblVehicleTrips	ST_TR	2.12	0.00
tblVehicleTrips	SU_TR	2.12	0.00
tblVehicleTrips	WD_TR	2.12	0.03
tblWater	IndoorWaterUseRate	40,293,000.00	3,259,000.00

2.0 Emissions Summary

Vega SES 4 Solar Energy Storage Project - Imperial County, Annual

EMFAC Off-Model Adjustment Factors for Gasoline Light Duty Vehicle to Account for the SAFE Vehicle Rule Not Applied

2.1 Overall Construction

Unmitigated Construction

	ROG	NOx	CO	SO2	Fugitive PM10	Exhaust PM10	PM10 Total	Fugitive PM2.5	Exhaust PM2.5	PM2.5 Total	Bio- CO2	NBio- CO2	Total CO2	CH4	N2O	CO2e
Year	tons/yr										MT/yr					
2023	0.5427	4.2187	5.1222	0.0102	71.3792	0.1872	71.5664	7.3462	0.1724	7.5187	0.0000	904.2814	904.2814	0.2172	0.0118	913.2157
2024	0.3534	2.2421	3.6710	6.8000e-003	68.3411	0.1050	68.4461	6.8642	0.0969	6.9611	0.0000	605.1367	605.1367	0.1231	9.7000e-003	611.1068
Maximum	0.5427	4.2187	5.1222	0.0102	71.3792	0.1872	71.5664	7.3462	0.1724	7.5187	0.0000	904.2814	904.2814	0.2172	0.0118	913.2157

Mitigated Construction

	ROG	NOx	CO	SO2	Fugitive PM10	Exhaust PM10	PM10 Total	Fugitive PM2.5	Exhaust PM2.5	PM2.5 Total	Bio- CO2	NBio- CO2	Total CO2	CH4	N2O	CO2e
Year	tons/yr										MT/yr					
2023	0.5427	4.2187	5.1222	0.0102	6.9534	0.1872	7.1406	0.8066	0.1724	0.9791	0.0000	904.2807	904.2807	0.2172	0.0118	913.2149
2024	0.3534	2.2421	3.6710	6.8000e-003	6.5164	0.1050	6.6214	0.6940	0.0969	0.7909	0.0000	605.1363	605.1363	0.1231	9.7000e-003	611.1063
Maximum	0.5427	4.2187	5.1222	0.0102	6.9534	0.1872	7.1406	0.8066	0.1724	0.9791	0.0000	904.2807	904.2807	0.2172	0.0118	913.2149

Vega SES 4 Solar Energy Storage Project - Imperial County, Annual

EMFAC Off-Model Adjustment Factors for Gasoline Light Duty Vehicle to Account for the SAFE Vehicle Rule Not Applied

	ROG	NOx	CO	SO2	Fugitive PM10	Exhaust PM10	PM10 Total	Fugitive PM2.5	Exhaust PM2.5	PM2.5 Total	Bio- CO2	NBio-CO2	Total CO2	CH4	N2O	CO2e
Percent Reduction	0.00	0.00	0.00	0.00	90.36	0.00	90.17	89.44	0.00	87.78	0.00	0.00	0.00	0.00	0.00	0.00

Quarter	Start Date	End Date	Maximum Unmitigated ROG + NOX (tons/quarter)	Maximum Mitigated ROG + NOX (tons/quarter)
5	12-3-2022	3-2-2023	0.0978	0.0978
6	3-3-2023	6-2-2023	1.7160	1.7160
7	6-3-2023	9-2-2023	1.3962	1.3962
8	9-3-2023	12-2-2023	1.1934	1.1934
9	12-3-2023	3-2-2024	1.1478	1.1478
10	3-3-2024	6-2-2024	1.1522	1.1522
11	6-3-2024	9-2-2024	0.6666	0.6666
		Highest	1.7160	1.7160

Vega SES 4 Solar Energy Storage Project - Imperial County, Annual

EMFAC Off-Model Adjustment Factors for Gasoline Light Duty Vehicle to Account for the SAFE Vehicle Rule Not Applied

2.2 Overall Operational

Unmitigated Operational

	ROG	NOx	CO	SO2	Fugitive PM10	Exhaust PM10	PM10 Total	Fugitive PM2.5	Exhaust PM2.5	PM2.5 Total	Bio- CO2	NBio- CO2	Total CO2	CH4	N2O	CO2e
Category	tons/yr										MT/yr					
Area	2.4800	5.0000e-005	5.7400e-003	0.0000		2.0000e-005	2.0000e-005		2.0000e-005	2.0000e-005	0.0000	0.0112	0.0112	3.0000e-005	0.0000	0.0119
Energy	0.0486	0.4418	0.3711	2.6500e-003		0.0336	0.0336		0.0336	0.0336	0.0000	1,079.1835	1,079.1835	0.1131	0.0214	1,088.3928
Mobile	3.0600e-003	4.9800e-003	0.0337	8.0000e-005	0.6299	6.0000e-005	0.6300	0.0640	5.0000e-005	0.0640	0.0000	7.0965	7.0965	3.0000e-004	3.3000e-004	7.2024
Offroad	4.6400e-003	0.0444	0.0508	9.0000e-005		2.2500e-003	2.2500e-003		2.0700e-003	2.0700e-003	0.0000	7.6084	7.6084	2.4600e-003	0.0000	7.6699
Waste						0.0000	0.0000		0.0000	0.0000	33.2479	0.0000	33.2479	1.9649	0.0000	82.3702
Water						0.0000	0.0000		0.0000	0.0000	1.0339	3.6568	4.6907	0.1068	2.5800e-003	8.1317
Total	2.5363	0.4913	0.4614	2.8200e-003	0.6299	0.0359	0.6658	0.0640	0.0357	0.0997	34.2818	1,097.5564	1,131.8382	2.1876	0.0243	1,193.7789

Vega SES 4 Solar Energy Storage Project - Imperial County, Annual

EMFAC Off-Model Adjustment Factors for Gasoline Light Duty Vehicle to Account for the SAFE Vehicle Rule Not Applied

2.2 Overall Operational

Mitigated Operational

	ROG	NOx	CO	SO2	Fugitive PM10	Exhaust PM10	PM10 Total	Fugitive PM2.5	Exhaust PM2.5	PM2.5 Total	Bio- CO2	NBio- CO2	Total CO2	CH4	N2O	CO2e
Category	tons/yr										MT/yr					
Area	2.4800	5.0000e-005	5.7400e-003	0.0000		2.0000e-005	2.0000e-005		2.0000e-005	2.0000e-005	0.0000	0.0112	0.0112	3.0000e-005	0.0000	0.0119
Energy	0.0486	0.4418	0.3711	2.6500e-003		0.0336	0.0336		0.0336	0.0336	0.0000	480.9912	480.9912	9.2200e-003	8.8200e-003	483.8495
Mobile	3.0600e-003	4.9800e-003	0.0337	8.0000e-005	0.6299	6.0000e-005	0.6300	0.0640	5.0000e-005	0.0640	0.0000	7.0965	7.0965	3.0000e-004	3.3000e-004	7.2024
Offroad	4.6400e-003	0.0444	0.0508	9.0000e-005		2.2500e-003	2.2500e-003		2.0700e-003	2.0700e-003	0.0000	7.6084	7.6084	2.4600e-003	0.0000	7.6699
Waste						0.0000	0.0000		0.0000	0.0000	33.2479	0.0000	33.2479	1.9649	0.0000	82.3702
Water						0.0000	0.0000		0.0000	0.0000	1.0339	3.6568	4.6907	0.1068	2.5800e-003	8.1317
Total	2.5363	0.4913	0.4614	2.8200e-003	0.6299	0.0359	0.6658	0.0640	0.0357	0.0997	34.2818	499.3641	533.6459	2.0837	0.0117	589.2356

	ROG	NOx	CO	SO2	Fugitive PM10	Exhaust PM10	PM10 Total	Fugitive PM2.5	Exhaust PM2.5	PM2.5 Total	Bio- CO2	NBio-CO2	Total CO2	CH4	N2O	CO2e
Percent Reduction	0.00	0.00	0.00	0.00	0.00	0.00	0.00	0.00	0.00	0.00	0.00	54.50	52.85	4.75	51.77	50.64

3.0 Construction Detail

Construction Phase

Phase Number	Phase Name	Phase Type	Start Date	End Date	Num Days Week	Num Days	Phase Description
1	Site Preparation	Site Preparation	2/3/2023	3/21/2023	5	33	
2	Grading	Grading	3/22/2023	6/2/2023	5	66	

PC ORIGINAL PKG

Vega SES 4 Solar Energy Storage Project - Imperial County, Annual

EMFAC Off-Model Adjustment Factors for Gasoline Light Duty Vehicle to Account for the SAFE Vehicle Rule Not Applied

3	Building Construction	Building Construction	6/22/2023	7/25/2024	5	286
---	-----------------------	-----------------------	-----------	-----------	---	-----

Acres of Grading (Site Preparation Phase): 0

Acres of Grading (Grading Phase): 297

Acres of Paving: 450.5

Residential Indoor: 0; Residential Outdoor: 0; Non-Residential Indoor: 0; Non-Residential Outdoor: 0; Striped Parking Area: 0 (Architectural Coating – sqft)

OffRoad Equipment

Phase Name	Offroad Equipment Type	Amount	Usage Hours	Horse Power	Load Factor
Site Preparation	Rubber Tired Dozers	0	8.00	247	0.40
Site Preparation	Tractors/Loaders/Backhoes	2	8.00	97	0.37
Grading	Excavators	4	8.00	158	0.38
Grading	Graders	3	8.00	187	0.41
Grading	Rubber Tired Dozers	2	8.00	247	0.40
Grading	Scrapers	2	8.00	367	0.48
Grading	Tractors/Loaders/Backhoes	4	8.00	97	0.37
Building Construction	Cranes	1	7.00	231	0.29
Building Construction	Forklifts	0	8.00	89	0.20
Building Construction	Generator Sets	0	8.00	84	0.74
Site Preparation	Rubber Tired Loaders	2	8.00	203	0.36
Building Construction	Rough Terrain Forklifts	4	8.00	100	0.40
Building Construction	Pavers	1	8.00	130	0.42
Building Construction	Tractors/Loaders/Backhoes	4	7.00	97	0.37
Building Construction	Paving Equipment	2	8.00	132	0.36
Building Construction	Welders	0	8.00	46	0.45
Building Construction	Plate Compactors	4	8.00	8	0.43
Building Construction	Trenchers	2	8.00	78	0.50
Building Construction	Rollers	2	8.00	80	0.38

PC ORIGINAL PKG

Vega SES 4 Solar Energy Storage Project - Imperial County, Annual

EMFAC Off-Model Adjustment Factors for Gasoline Light Duty Vehicle to Account for the SAFE Vehicle Rule Not Applied

Trips and VMT

Phase Name	Offroad Equipment Count	Worker Trip Number	Vendor Trip Number	Hauling Trip Number	Worker Trip Length	Vendor Trip Length	Hauling Trip Length	Worker Vehicle Class	Vendor Vehicle Class	Hauling Vehicle Class
Site Preparation	4	10.00	4.00	0.00	10.20	32.15	20.00	LD_Mix	HDT_Mix	HHDT
Grading	15	38.00	4.00	0.00	10.20	32.15	20.00	LD_Mix	HDT_Mix	HHDT
Building Construction	20	500.00	4.00	0.00	10.20	32.15	20.00	LD_Mix	HDT_Mix	HHDT

3.1 Mitigation Measures Construction

Use Soil Stabilizer

Water Exposed Area

Water Unpaved Roads

Reduce Vehicle Speed on Unpaved Roads

3.2 Site Preparation - 2023

Unmitigated Construction On-Site

	ROG	NOx	CO	SO2	Fugitive PM10	Exhaust PM10	PM10 Total	Fugitive PM2.5	Exhaust PM2.5	PM2.5 Total	Bio- CO2	NBio- CO2	Total CO2	CH4	N2O	CO2e
Category	tons/yr										MT/yr					
Fugitive Dust					0.0000	0.0000	0.0000	0.0000	0.0000	0.0000	0.0000	0.0000	0.0000	0.0000	0.0000	0.0000
Off-Road	0.0140	0.1387	0.1237	3.1000e-004		5.4500e-003	5.4500e-003		5.0100e-003	5.0100e-003	0.0000	27.2477	27.2477	8.8100e-003	0.0000	27.4680
Total	0.0140	0.1387	0.1237	3.1000e-004	0.0000	5.4500e-003	5.4500e-003	0.0000	5.0100e-003	5.0100e-003	0.0000	27.2477	27.2477	8.8100e-003	0.0000	27.4680

Vega SES 4 Solar Energy Storage Project - Imperial County, Annual

EMFAC Off-Model Adjustment Factors for Gasoline Light Duty Vehicle to Account for the SAFE Vehicle Rule Not Applied

3.2 Site Preparation - 2023

Unmitigated Construction Off-Site

	ROG	NOx	CO	SO2	Fugitive PM10	Exhaust PM10	PM10 Total	Fugitive PM2.5	Exhaust PM2.5	PM2.5 Total	Bio- CO2	NBio- CO2	Total CO2	CH4	N2O	CO2e
Category	tons/yr										MT/yr					
Hauling	0.0000	0.0000	0.0000	0.0000	0.0000	0.0000	0.0000	0.0000	0.0000	0.0000	0.0000	0.0000	0.0000	0.0000	0.0000	0.0000
Vendor	3.2000e-004	7.2900e-003	2.1800e-003	5.0000e-005	1.9037	9.0000e-005	1.9038	0.1902	8.0000e-005	0.1903	0.0000	4.8556	4.8556	1.0000e-005	6.6000e-004	5.0540
Worker	6.7000e-004	3.9000e-004	4.6300e-003	1.0000e-005	0.2646	1.0000e-005	0.2647	0.0266	1.0000e-005	0.0266	0.0000	0.9941	0.9941	3.0000e-005	3.0000e-005	1.0045
Total	9.9000e-004	7.6800e-003	6.8100e-003	6.0000e-005	2.1684	1.0000e-004	2.1685	0.2168	9.0000e-005	0.2169	0.0000	5.8496	5.8496	4.0000e-005	6.9000e-004	6.0586

Mitigated Construction On-Site

	ROG	NOx	CO	SO2	Fugitive PM10	Exhaust PM10	PM10 Total	Fugitive PM2.5	Exhaust PM2.5	PM2.5 Total	Bio- CO2	NBio- CO2	Total CO2	CH4	N2O	CO2e
Category	tons/yr										MT/yr					
Fugitive Dust					0.0000	0.0000	0.0000	0.0000	0.0000	0.0000	0.0000	0.0000	0.0000	0.0000	0.0000	0.0000
Off-Road	0.0140	0.1387	0.1237	3.1000e-004		5.4500e-003	5.4500e-003		5.0100e-003	5.0100e-003	0.0000	27.2477	27.2477	8.8100e-003	0.0000	27.4680
Total	0.0140	0.1387	0.1237	3.1000e-004	0.0000	5.4500e-003	5.4500e-003	0.0000	5.0100e-003	5.0100e-003	0.0000	27.2477	27.2477	8.8100e-003	0.0000	27.4680

Vega SES 4 Solar Energy Storage Project - Imperial County, Annual

EMFAC Off-Model Adjustment Factors for Gasoline Light Duty Vehicle to Account for the SAFE Vehicle Rule Not Applied

3.2 Site Preparation - 2023

Mitigated Construction Off-Site

	ROG	NOx	CO	SO2	Fugitive PM10	Exhaust PM10	PM10 Total	Fugitive PM2.5	Exhaust PM2.5	PM2.5 Total	Bio- CO2	NBio- CO2	Total CO2	CH4	N2O	CO2e
Category	tons/yr										MT/yr					
Hauling	0.0000	0.0000	0.0000	0.0000	0.0000	0.0000	0.0000	0.0000	0.0000	0.0000	0.0000	0.0000	0.0000	0.0000	0.0000	0.0000
Vendor	3.2000e-004	7.2900e-003	2.1800e-003	5.0000e-005	0.1758	9.0000e-005	0.1759	0.0178	8.0000e-005	0.0178	0.0000	4.8556	4.8556	1.0000e-005	6.6000e-004	5.0540
Worker	6.7000e-004	3.9000e-004	4.6300e-003	1.0000e-005	0.0254	1.0000e-005	0.0254	2.7200e-003	1.0000e-005	2.7200e-003	0.0000	0.9941	0.9941	3.0000e-005	3.0000e-005	1.0045
Total	9.9000e-004	7.6800e-003	6.8100e-003	6.0000e-005	0.2012	1.0000e-004	0.2013	0.0205	9.0000e-005	0.0206	0.0000	5.8496	5.8496	4.0000e-005	6.9000e-004	6.0586

3.3 Grading - 2023

Unmitigated Construction On-Site

	ROG	NOx	CO	SO2	Fugitive PM10	Exhaust PM10	PM10 Total	Fugitive PM2.5	Exhaust PM2.5	PM2.5 Total	Bio- CO2	NBio- CO2	Total CO2	CH4	N2O	CO2e
Category	tons/yr										MT/yr					
Fugitive Dust					0.5549	0.0000	0.5549	0.2355	0.0000	0.2355	0.0000	0.0000	0.0000	0.0000	0.0000	0.0000
Off-Road	0.1800	1.8849	1.5022	3.3100e-003		0.0776	0.0776		0.0714	0.0714	0.0000	291.0949	291.0949	0.0942	0.0000	293.4486
Total	0.1800	1.8849	1.5022	3.3100e-003	0.5549	0.0776	0.6325	0.2355	0.0714	0.3068	0.0000	291.0949	291.0949	0.0942	0.0000	293.4486

Vega SES 4 Solar Energy Storage Project - Imperial County, Annual

EMFAC Off-Model Adjustment Factors for Gasoline Light Duty Vehicle to Account for the SAFE Vehicle Rule Not Applied

3.3 Grading - 2023

Unmitigated Construction Off-Site

	ROG	NOx	CO	SO2	Fugitive PM10	Exhaust PM10	PM10 Total	Fugitive PM2.5	Exhaust PM2.5	PM2.5 Total	Bio- CO2	NBio- CO2	Total CO2	CH4	N2O	CO2e
Category	tons/yr										MT/yr					
Hauling	0.0000	0.0000	0.0000	0.0000	0.0000	0.0000	0.0000	0.0000	0.0000	0.0000	0.0000	0.0000	0.0000	0.0000	0.0000	0.0000
Vendor	6.3000e-004	0.0146	4.3700e-003	1.0000e-004	3.8075	1.7000e-004	3.8076	0.3804	1.7000e-004	0.3806	0.0000	9.7112	9.7112	3.0000e-005	1.3300e-003	10.1080
Worker	5.0800e-003	2.9800e-003	0.0352	8.0000e-005	2.0113	5.0000e-005	2.0113	0.2022	4.0000e-005	0.2022	0.0000	7.5548	7.5548	2.5000e-004	2.5000e-004	7.6345
Total	5.7100e-003	0.0176	0.0395	1.8000e-004	5.8188	2.2000e-004	5.8190	0.5826	2.1000e-004	0.5828	0.0000	17.2659	17.2659	2.8000e-004	1.5800e-003	17.7426

Mitigated Construction On-Site

	ROG	NOx	CO	SO2	Fugitive PM10	Exhaust PM10	PM10 Total	Fugitive PM2.5	Exhaust PM2.5	PM2.5 Total	Bio- CO2	NBio- CO2	Total CO2	CH4	N2O	CO2e
Category	tons/yr										MT/yr					
Fugitive Dust					0.2164	0.0000	0.2164	0.0918	0.0000	0.0918	0.0000	0.0000	0.0000	0.0000	0.0000	0.0000
Off-Road	0.1800	1.8849	1.5022	3.3100e-003		0.0776	0.0776		0.0714	0.0714	0.0000	291.0946	291.0946	0.0942	0.0000	293.4483
Total	0.1800	1.8849	1.5022	3.3100e-003	0.2164	0.0776	0.2940	0.0918	0.0714	0.1632	0.0000	291.0946	291.0946	0.0942	0.0000	293.4483

Vega SES 4 Solar Energy Storage Project - Imperial County, Annual

EMFAC Off-Model Adjustment Factors for Gasoline Light Duty Vehicle to Account for the SAFE Vehicle Rule Not Applied

3.3 Grading - 2023

Mitigated Construction Off-Site

	ROG	NOx	CO	SO2	Fugitive PM10	Exhaust PM10	PM10 Total	Fugitive PM2.5	Exhaust PM2.5	PM2.5 Total	Bio- CO2	NBio- CO2	Total CO2	CH4	N2O	CO2e
Category	tons/yr										MT/yr					
Hauling	0.0000	0.0000	0.0000	0.0000	0.0000	0.0000	0.0000	0.0000	0.0000	0.0000	0.0000	0.0000	0.0000	0.0000	0.0000	0.0000
Vendor	6.3000e-004	0.0146	4.3700e-003	1.0000e-004	0.3516	1.7000e-004	0.3518	0.0355	1.7000e-004	0.0357	0.0000	9.7112	9.7112	3.0000e-005	1.3300e-003	10.1080
Worker	5.0800e-003	2.9800e-003	0.0352	8.0000e-005	0.1927	5.0000e-005	0.1927	0.0207	4.0000e-005	0.0207	0.0000	7.5548	7.5548	2.5000e-004	2.5000e-004	7.6345
Total	5.7100e-003	0.0176	0.0395	1.8000e-004	0.5443	2.2000e-004	0.5445	0.0562	2.1000e-004	0.0564	0.0000	17.2659	17.2659	2.8000e-004	1.5800e-003	17.7426

3.4 Building Construction - 2023

Unmitigated Construction On-Site

	ROG	NOx	CO	SO2	Fugitive PM10	Exhaust PM10	PM10 Total	Fugitive PM2.5	Exhaust PM2.5	PM2.5 Total	Bio- CO2	NBio- CO2	Total CO2	CH4	N2O	CO2e
Category	tons/yr										MT/yr					
Off-Road	0.2021	2.0582	2.4807	3.8600e-003		0.1022	0.1022		0.0942	0.0942	0.0000	336.3250	336.3250	0.1069	0.0000	338.9973
Total	0.2021	2.0582	2.4807	3.8600e-003		0.1022	0.1022		0.0942	0.0942	0.0000	336.3250	336.3250	0.1069	0.0000	338.9973

Vega SES 4 Solar Energy Storage Project - Imperial County, Annual

EMFAC Off-Model Adjustment Factors for Gasoline Light Duty Vehicle to Account for the SAFE Vehicle Rule Not Applied

3.4 Building Construction - 2023

Unmitigated Construction Off-Site

	ROG	NOx	CO	SO2	Fugitive PM10	Exhaust PM10	PM10 Total	Fugitive PM2.5	Exhaust PM2.5	PM2.5 Total	Bio- CO2	NBio- CO2	Total CO2	CH4	N2O	CO2e
Category	tons/yr										MT/yr					
Hauling	0.0000	0.0000	0.0000	0.0000	0.0000	0.0000	0.0000	0.0000	0.0000	0.0000	0.0000	0.0000	0.0000	0.0000	0.0000	0.0000
Vendor	1.3200e-003	0.0303	9.0700e-003	2.1000e-004	7.9034	3.6000e-004	7.9037	0.7897	3.4000e-004	0.7900	0.0000	20.1580	20.1580	6.0000e-005	2.7600e-003	20.9818
Worker	0.1387	0.0813	0.9602	2.2500e-003	54.9337	1.3200e-003	54.9350	5.5217	1.2100e-003	5.5229	0.0000	206.3403	206.3403	6.9400e-003	6.7300e-003	208.5188
Total	0.1400	0.1116	0.9692	2.4600e-003	62.8371	1.6800e-003	62.8388	6.3114	1.5500e-003	6.3129	0.0000	226.4983	226.4983	7.0000e-003	9.4900e-003	229.5007

Mitigated Construction On-Site

	ROG	NOx	CO	SO2	Fugitive PM10	Exhaust PM10	PM10 Total	Fugitive PM2.5	Exhaust PM2.5	PM2.5 Total	Bio- CO2	NBio- CO2	Total CO2	CH4	N2O	CO2e
Category	tons/yr										MT/yr					
Off-Road	0.2021	2.0582	2.4807	3.8600e-003		0.1022	0.1022		0.0942	0.0942	0.0000	336.3246	336.3246	0.1069	0.0000	338.9969
Total	0.2021	2.0582	2.4807	3.8600e-003		0.1022	0.1022		0.0942	0.0942	0.0000	336.3246	336.3246	0.1069	0.0000	338.9969

Vega SES 4 Solar Energy Storage Project - Imperial County, Annual

EMFAC Off-Model Adjustment Factors for Gasoline Light Duty Vehicle to Account for the SAFE Vehicle Rule Not Applied

3.4 Building Construction - 2023

Mitigated Construction Off-Site

	ROG	NOx	CO	SO2	Fugitive PM10	Exhaust PM10	PM10 Total	Fugitive PM2.5	Exhaust PM2.5	PM2.5 Total	Bio- CO2	NBio- CO2	Total CO2	CH4	N2O	CO2e
Category	tons/yr										MT/yr					
Hauling	0.0000	0.0000	0.0000	0.0000	0.0000	0.0000	0.0000	0.0000	0.0000	0.0000	0.0000	0.0000	0.0000	0.0000	0.0000	0.0000
Vendor	1.3200e-003	0.0303	9.0700e-003	2.1000e-004	0.7299	3.6000e-004	0.7303	0.0737	3.4000e-004	0.0741	0.0000	20.1580	20.1580	6.0000e-005	2.7600e-003	20.9818
Worker	0.1387	0.0813	0.9602	2.2500e-003	5.2617	1.3200e-003	5.2630	0.5644	1.2100e-003	0.5656	0.0000	206.3403	206.3403	6.9400e-003	6.7300e-003	208.5188
Total	0.1400	0.1116	0.9692	2.4600e-003	5.9916	1.6800e-003	5.9933	0.6381	1.5500e-003	0.6397	0.0000	226.4983	226.4983	7.0000e-003	9.4900e-003	229.5007

3.4 Building Construction - 2024

Unmitigated Construction On-Site

	ROG	NOx	CO	SO2	Fugitive PM10	Exhaust PM10	PM10 Total	Fugitive PM2.5	Exhaust PM2.5	PM2.5 Total	Bio- CO2	NBio- CO2	Total CO2	CH4	N2O	CO2e
Category	tons/yr										MT/yr					
Off-Road	0.2119	2.1309	2.6981	4.2000e-003		0.1033	0.1033		0.0952	0.0952	0.0000	365.8059	365.8059	0.1163	0.0000	368.7125
Total	0.2119	2.1309	2.6981	4.2000e-003		0.1033	0.1033		0.0952	0.0952	0.0000	365.8059	365.8059	0.1163	0.0000	368.7125

Vega SES 4 Solar Energy Storage Project - Imperial County, Annual

EMFAC Off-Model Adjustment Factors for Gasoline Light Duty Vehicle to Account for the SAFE Vehicle Rule Not Applied

3.4 Building Construction - 2024

Unmitigated Construction Off-Site

	ROG	NOx	CO	SO2	Fugitive PM10	Exhaust PM10	PM10 Total	Fugitive PM2.5	Exhaust PM2.5	PM2.5 Total	Bio- CO2	NBio- CO2	Total CO2	CH4	N2O	CO2e
Category	tons/yr										MT/yr					
Hauling	0.0000	0.0000	0.0000	0.0000	0.0000	0.0000	0.0000	0.0000	0.0000	0.0000	0.0000	0.0000	0.0000	0.0000	0.0000	0.0000
Vendor	1.3600e-003	0.0328	9.2200e-003	2.3000e-004	8.5956	3.9000e-004	8.5960	0.8588	3.7000e-004	0.8592	0.0000	21.6265	21.6265	6.0000e-005	2.9400e-003	22.5053
Worker	0.1402	0.0784	0.9637	2.3700e-003	59.7454	1.3600e-003	59.7468	6.0054	1.2500e-003	6.0066	0.0000	217.7043	217.7043	6.8200e-003	6.7600e-003	219.8890
Total	0.1415	0.1112	0.9729	2.6000e-003	68.3411	1.7500e-003	68.3428	6.8642	1.6200e-003	6.8658	0.0000	239.3308	239.3308	6.8800e-003	9.7000e-003	242.3943

Mitigated Construction On-Site

	ROG	NOx	CO	SO2	Fugitive PM10	Exhaust PM10	PM10 Total	Fugitive PM2.5	Exhaust PM2.5	PM2.5 Total	Bio- CO2	NBio- CO2	Total CO2	CH4	N2O	CO2e
Category	tons/yr										MT/yr					
Off-Road	0.2119	2.1309	2.6981	4.2000e-003		0.1033	0.1033		0.0952	0.0952	0.0000	365.8055	365.8055	0.1163	0.0000	368.7120
Total	0.2119	2.1309	2.6981	4.2000e-003		0.1033	0.1033		0.0952	0.0952	0.0000	365.8055	365.8055	0.1163	0.0000	368.7120

Vega SES 4 Solar Energy Storage Project - Imperial County, Annual

EMFAC Off-Model Adjustment Factors for Gasoline Light Duty Vehicle to Account for the SAFE Vehicle Rule Not Applied

3.4 Building Construction - 2024

Mitigated Construction Off-Site

	ROG	NOx	CO	SO2	Fugitive PM10	Exhaust PM10	PM10 Total	Fugitive PM2.5	Exhaust PM2.5	PM2.5 Total	Bio- CO2	NBio- CO2	Total CO2	CH4	N2O	CO2e
Category	tons/yr										MT/yr					
Hauling	0.0000	0.0000	0.0000	0.0000	0.0000	0.0000	0.0000	0.0000	0.0000	0.0000	0.0000	0.0000	0.0000	0.0000	0.0000	0.0000
Vendor	1.3600e-003	0.0328	9.2200e-003	2.3000e-004	0.7938	3.9000e-004	0.7942	0.0802	3.7000e-004	0.0806	0.0000	21.6265	21.6265	6.0000e-005	2.9400e-003	22.5053
Worker	0.1402	0.0784	0.9637	2.3700e-003	5.7226	1.3600e-003	5.7239	0.6138	1.2500e-003	0.6151	0.0000	217.7043	217.7043	6.8200e-003	6.7600e-003	219.8890
Total	0.1415	0.1112	0.9729	2.6000e-003	6.5164	1.7500e-003	6.5181	0.6940	1.6200e-003	0.6957	0.0000	239.3308	239.3308	6.8800e-003	9.7000e-003	242.3943

4.0 Operational Detail - Mobile

4.1 Mitigation Measures Mobile

Vega SES 4 Solar Energy Storage Project - Imperial County, Annual

EMFAC Off-Model Adjustment Factors for Gasoline Light Duty Vehicle to Account for the SAFE Vehicle Rule Not Applied

	ROG	NOx	CO	SO2	Fugitive PM10	Exhaust PM10	PM10 Total	Fugitive PM2.5	Exhaust PM2.5	PM2.5 Total	Bio- CO2	NBio- CO2	Total CO2	CH4	N2O	CO2e
Category	tons/yr										MT/yr					
Mitigated	3.0600e-003	4.9800e-003	0.0337	8.0000e-005	0.6299	6.0000e-005	0.6300	0.0640	5.0000e-005	0.0640	0.0000	7.0965	7.0965	3.0000e-004	3.3000e-004	7.2024
Unmitigated	3.0600e-003	4.9800e-003	0.0337	8.0000e-005	0.6299	6.0000e-005	0.6300	0.0640	5.0000e-005	0.0640	0.0000	7.0965	7.0965	3.0000e-004	3.3000e-004	7.2024

4.2 Trip Summary Information

Land Use	Average Daily Trip Rate			Unmitigated	Mitigated
	Weekday	Saturday	Sunday	Annual VMT	Annual VMT
Refrigerated Warehouse-No Rail	2.96	0.00	0.00	10,455	10,455
Refrigerated Warehouse-No Rail	2.96	0.00	0.00	10,455	10,455
Other Non-Asphalt Surfaces	0.00	0.00	0.00		
Other Non-Asphalt Surfaces	0.00	0.00	0.00		
Total	5.92	0.00	0.00	20,910	20,910

4.3 Trip Type Information

Land Use	Miles			Trip %			Trip Purpose %		
	H-W or C-W	H-S or C-C	H-O or C-NW	H-W or C-W	H-S or C-C	H-O or C-NW	Primary	Diverted	Pass-by
Refrigerated Warehouse-No	16.40	9.50	11.90	59.00	0.00	41.00	92	5	3
Refrigerated Warehouse-No	16.40	9.50	11.90	59.00	0.00	41.00	92	5	3
Other Non-Asphalt Surfaces	16.40	9.50	11.90	0.00	0.00	0.00	0	0	0
Other Non-Asphalt Surfaces	16.40	9.50	11.90	0.00	0.00	0.00	0	0	0

4.4 Fleet Mix

Vega SES 4 Solar Energy Storage Project - Imperial County, Annual

EMFAC Off-Model Adjustment Factors for Gasoline Light Duty Vehicle to Account for the SAFE Vehicle Rule Not Applied

Land Use	LDA	LDT1	LDT2	MDV	LHD1	LHD2	MHD	HHD	OBUS	UBUS	MCY	SBUS	MH
Refrigerated Warehouse-No Rail	0.521846	0.059402	0.180067	0.151114	0.027614	0.006908	0.008276	0.016396	0.000918	0.000121	0.022925	0.000779	0.003633
Other Non-Asphalt Surfaces	0.521846	0.059402	0.180067	0.151114	0.027614	0.006908	0.008276	0.016396	0.000918	0.000121	0.022925	0.000779	0.003633

5.0 Energy Detail

Historical Energy Use: N

5.1 Mitigation Measures Energy

Percent of Electricity Use Generated with Renewable Energy

Category	ROG	NOx	CO	SO2	Fugitive PM10	Exhaust PM10	PM10 Total	Fugitive PM2.5	Exhaust PM2.5	PM2.5 Total	Bio- CO2	NBio- CO2	Total CO2	CH4	N2O	CO2e
Category	tons/yr										MT/yr					
Electricity Mitigated						0.0000	0.0000		0.0000	0.0000	0.0000	0.0000	0.0000	0.0000	0.0000	0.0000
Electricity Unmitigated						0.0000	0.0000		0.0000	0.0000	0.0000	598.1923	598.1923	0.1039	0.0126	604.5433
NaturalGas Mitigated	0.0486	0.4418	0.3711	2.6500e-003		0.0336	0.0336		0.0336	0.0336	0.0000	480.9912	480.9912	9.2200e-003	8.8200e-003	483.8495
NaturalGas Unmitigated	0.0486	0.4418	0.3711	2.6500e-003		0.0336	0.0336		0.0336	0.0336	0.0000	480.9912	480.9912	9.2200e-003	8.8200e-003	483.8495

Vega SES 4 Solar Energy Storage Project - Imperial County, Annual

EMFAC Off-Model Adjustment Factors for Gasoline Light Duty Vehicle to Account for the SAFE Vehicle Rule Not Applied

5.2 Energy by Land Use - Natural Gas

Unmitigated

	Natural Gas Use	ROG	NOx	CO	SO2	Fugitive PM10	Exhaust PM10	PM10 Total	Fugitive PM2.5	Exhaust PM2.5	PM2.5 Total	Bio- CO2	NBio- CO2	Total CO2	CH4	N2O	CO2e
Land Use	kBTU/yr	tons/yr										MT/yr					
Other Non-Asphalt Surfaces	0	0.0000	0.0000	0.0000	0.0000		0.0000	0.0000		0.0000	0.0000	0.0000	0.0000	0.0000	0.0000	0.0000	0.0000
Refrigerated Warehouse-No Rail	4.50672e+006	0.0486	0.4418	0.3711	2.6500e-003		0.0336	0.0336		0.0336	0.0336	0.0000	480.9912	480.9912	9.2200e-003	8.8200e-003	483.8495
Total		0.0486	0.4418	0.3711	2.6500e-003		0.0336	0.0336		0.0336	0.0336	0.0000	480.9912	480.9912	9.2200e-003	8.8200e-003	483.8495

Mitigated

	Natural Gas Use	ROG	NOx	CO	SO2	Fugitive PM10	Exhaust PM10	PM10 Total	Fugitive PM2.5	Exhaust PM2.5	PM2.5 Total	Bio- CO2	NBio- CO2	Total CO2	CH4	N2O	CO2e
Land Use	kBTU/yr	tons/yr										MT/yr					
Other Non-Asphalt Surfaces	0	0.0000	0.0000	0.0000	0.0000		0.0000	0.0000		0.0000	0.0000	0.0000	0.0000	0.0000	0.0000	0.0000	0.0000
Refrigerated Warehouse-No Rail	4.50672e+006	0.0486	0.4418	0.3711	2.6500e-003		0.0336	0.0336		0.0336	0.0336	0.0000	480.9912	480.9912	9.2200e-003	8.8200e-003	483.8495
Total		0.0486	0.4418	0.3711	2.6500e-003		0.0336	0.0336		0.0336	0.0336	0.0000	480.9912	480.9912	9.2200e-003	8.8200e-003	483.8495

Vega SES 4 Solar Energy Storage Project - Imperial County, Annual

EMFAC Off-Model Adjustment Factors for Gasoline Light Duty Vehicle to Account for the SAFE Vehicle Rule Not Applied

5.3 Energy by Land Use - Electricity

Unmitigated

	Electricity Use	Total CO2	CH4	N2O	CO2e
Land Use	kWh/yr	MT/yr			
Other Non-Asphalt Surfaces	0	0.0000	0.0000	0.0000	0.0000
Refrigerated Warehouse-No Rail	3.47086e+006	598.1923	0.1039	0.0126	604.5433
Total		598.1923	0.1039	0.0126	604.5433

Mitigated

	Electricity Use	Total CO2	CH4	N2O	CO2e
Land Use	kWh/yr	MT/yr			
Other Non-Asphalt Surfaces	0	0.0000	0.0000	0.0000	0.0000
Refrigerated Warehouse-No Rail	0	0.0000	0.0000	0.0000	0.0000
Total		0.0000	0.0000	0.0000	0.0000

6.0 Area Detail

Vega SES 4 Solar Energy Storage Project - Imperial County, Annual

EMFAC Off-Model Adjustment Factors for Gasoline Light Duty Vehicle to Account for the SAFE Vehicle Rule Not Applied

6.1 Mitigation Measures Area

	ROG	NOx	CO	SO2	Fugitive PM10	Exhaust PM10	PM10 Total	Fugitive PM2.5	Exhaust PM2.5	PM2.5 Total	Bio- CO2	NBio- CO2	Total CO2	CH4	N2O	CO2e
Category	tons/yr										MT/yr					
Mitigated	2.4800	5.0000e-005	5.7400e-003	0.0000		2.0000e-005	2.0000e-005		2.0000e-005	2.0000e-005	0.0000	0.0112	0.0112	3.0000e-005	0.0000	0.0119
Unmitigated	2.4800	5.0000e-005	5.7400e-003	0.0000		2.0000e-005	2.0000e-005		2.0000e-005	2.0000e-005	0.0000	0.0112	0.0112	3.0000e-005	0.0000	0.0119

6.2 Area by SubCategory

Unmitigated

	ROG	NOx	CO	SO2	Fugitive PM10	Exhaust PM10	PM10 Total	Fugitive PM2.5	Exhaust PM2.5	PM2.5 Total	Bio- CO2	NBio- CO2	Total CO2	CH4	N2O	CO2e
SubCategory	tons/yr										MT/yr					
Architectural Coating	0.5304					0.0000	0.0000		0.0000	0.0000	0.0000	0.0000	0.0000	0.0000	0.0000	0.0000
Consumer Products	1.9490					0.0000	0.0000		0.0000	0.0000	0.0000	0.0000	0.0000	0.0000	0.0000	0.0000
Landscaping	5.3000e-004	5.0000e-005	5.7400e-003	0.0000		2.0000e-005	2.0000e-005		2.0000e-005	2.0000e-005	0.0000	0.0112	0.0112	3.0000e-005	0.0000	0.0119
Total	2.4800	5.0000e-005	5.7400e-003	0.0000		2.0000e-005	2.0000e-005		2.0000e-005	2.0000e-005	0.0000	0.0112	0.0112	3.0000e-005	0.0000	0.0119

Vega SES 4 Solar Energy Storage Project - Imperial County, Annual

EMFAC Off-Model Adjustment Factors for Gasoline Light Duty Vehicle to Account for the SAFE Vehicle Rule Not Applied

6.2 Area by SubCategory

Mitigated

	ROG	NOx	CO	SO2	Fugitive PM10	Exhaust PM10	PM10 Total	Fugitive PM2.5	Exhaust PM2.5	PM2.5 Total	Bio- CO2	NBio- CO2	Total CO2	CH4	N2O	CO2e
SubCategory	tons/yr										MT/yr					
Architectural Coating	0.5304					0.0000	0.0000		0.0000	0.0000	0.0000	0.0000	0.0000	0.0000	0.0000	0.0000
Consumer Products	1.9490					0.0000	0.0000		0.0000	0.0000	0.0000	0.0000	0.0000	0.0000	0.0000	0.0000
Landscaping	5.3000e-004	5.0000e-005	5.7400e-003	0.0000		2.0000e-005	2.0000e-005		2.0000e-005	2.0000e-005	0.0000	0.0112	0.0112	3.0000e-005	0.0000	0.0119
Total	2.4800	5.0000e-005	5.7400e-003	0.0000		2.0000e-005	2.0000e-005		2.0000e-005	2.0000e-005	0.0000	0.0112	0.0112	3.0000e-005	0.0000	0.0119

7.0 Water Detail

7.1 Mitigation Measures Water

Vega SES 4 Solar Energy Storage Project - Imperial County, Annual

EMFAC Off-Model Adjustment Factors for Gasoline Light Duty Vehicle to Account for the SAFE Vehicle Rule Not Applied

	Total CO2	CH4	N2O	CO2e
Category	MT/yr			
Mitigated	4.6907	0.1068	2.5800e-003	8.1317
Unmitigated	4.6907	0.1068	2.5800e-003	8.1317

7.2 Water by Land Use

Unmitigated

	Indoor/Outdoor Use	Total CO2	CH4	N2O	CO2e
Land Use	Mgal	MT/yr			
Other Non-Asphalt Surfaces	0 / 0	0.0000	0.0000	0.0000	0.0000
Refrigerated Warehouse-No Rail	3.259 / 0	4.6907	0.1068	2.5800e-003	8.1317
Total		4.6907	0.1068	2.5800e-003	8.1317

Vega SES 4 Solar Energy Storage Project - Imperial County, Annual

EMFAC Off-Model Adjustment Factors for Gasoline Light Duty Vehicle to Account for the SAFE Vehicle Rule Not Applied

7.2 Water by Land Use

Mitigated

	Indoor/Outdoor Use	Total CO2	CH4	N2O	CO2e
Land Use	Mgal	MT/yr			
Other Non-Asphalt Surfaces	0 / 0	0.0000	0.0000	0.0000	0.0000
Refrigerated Warehouse-No Rail	3.259 / 0	4.6907	0.1068	2.5800e-003	8.1317
Total		4.6907	0.1068	2.5800e-003	8.1317

8.0 Waste Detail

8.1 Mitigation Measures Waste

Category/Year

	Total CO2	CH4	N2O	CO2e
	MT/yr			
Mitigated	33.2479	1.9649	0.0000	82.3702
Unmitigated	33.2479	1.9649	0.0000	82.3702

Vega SES 4 Solar Energy Storage Project - Imperial County, Annual

EMFAC Off-Model Adjustment Factors for Gasoline Light Duty Vehicle to Account for the SAFE Vehicle Rule Not Applied

8.2 Waste by Land Use

Unmitigated

	Waste Disposed	Total CO2	CH4	N2O	CO2e
Land Use	tons	MT/yr			
Other Non-Asphalt Surfaces	0	0.0000	0.0000	0.0000	0.0000
Refrigerated Warehouse-No Rail	163.79	33.2479	1.9649	0.0000	82.3702
Total		33.2479	1.9649	0.0000	82.3702

Mitigated

	Waste Disposed	Total CO2	CH4	N2O	CO2e
Land Use	tons	MT/yr			
Other Non-Asphalt Surfaces	0	0.0000	0.0000	0.0000	0.0000
Refrigerated Warehouse-No Rail	163.79	33.2479	1.9649	0.0000	82.3702
Total		33.2479	1.9649	0.0000	82.3702

Vega SES 4 Solar Energy Storage Project - Imperial County, Annual

EMFAC Off-Model Adjustment Factors for Gasoline Light Duty Vehicle to Account for the SAFE Vehicle Rule Not Applied

Equipment Type	Number	Hours/Day	Days/Year	Horse Power	Load Factor	Fuel Type
Other Construction Equipment	3	8.00	8	172	0.42	Diesel
Off-Highway Trucks	1	2.00	8	402	0.38	Diesel

UnMitigated/Mitigated

	ROG	NOx	CO	SO2	Fugitive PM10	Exhaust PM10	PM10 Total	Fugitive PM2.5	Exhaust PM2.5	PM2.5 Total	Bio- CO2	NBio- CO2	Total CO2	CH4	N2O	CO2e
Equipment Type	tons/yr										MT/yr					
Off-Highway Trucks	5.1000e-004	3.5900e-003	3.3000e-003	1.0000e-005		1.3000e-004	1.3000e-004		1.2000e-004	1.2000e-004	0.0000	1.1669	1.1669	3.8000e-004	0.0000	1.1763
Other Construction Equipment	4.1400e-003	0.0408	0.0475	7.0000e-005		2.1200e-003	2.1200e-003		1.9500e-003	1.9500e-003	0.0000	6.4415	6.4415	2.0800e-003	0.0000	6.4936
Total	4.6500e-003	0.0444	0.0508	8.0000e-005		2.2500e-003	2.2500e-003		2.0700e-003	2.0700e-003	0.0000	7.6084	7.6084	2.4600e-003	0.0000	7.6699

10.0 Stationary Equipment

Fire Pumps and Emergency Generators

Equipment Type	Number	Hours/Day	Hours/Year	Horse Power	Load Factor	Fuel Type
----------------	--------	-----------	------------	-------------	-------------	-----------

Boilers

Equipment Type	Number	Heat Input/Day	Heat Input/Year	Boiler Rating	Fuel Type
----------------	--------	----------------	-----------------	---------------	-----------

User Defined Equipment

Equipment Type	Number
----------------	--------

11.0 Vegetation

Vega SES 4 Solar Energy Storage Project - Imperial County, Annual

EMFAC Off-Model Adjustment Factors for Gasoline Light Duty Vehicle to Account for the SAFE Vehicle Rule Not Applied

Biological Technical Report

Vega SES 4 Solar Project

Imperial County, California

Prepared for:

Vega SES 4, LLC
604 Sutter Street
Suite 250
Folsom, California 95630

Submitted by:

ECORP Consulting, Inc.
3838 Camino Del Rio North
Suite 370
San Diego, California 92108
(858) 279-4040

November 2020

Revised July 2022



ECORP Consulting, Inc.
ENVIRONMENTAL CONSULTANTS

PC ORIGINAL PKG

CONTENTS

1.0 INTRODUCTION.....4

 1.1 Purpose of the Report.....4

 1.2 Project Location and Description.....4

2.0 REGULATORY CONSIDERATIONS.....7

 2.1 Federal Regulations.....7

 2.1.1 Endangered Species Act.....7

 2.1.2 Migratory Bird Treaty Act.....7

 2.1.3 Clean Water Act.....8

 2.2 State and Local Regulations.....8

 2.2.1 California Endangered Species Act.....8

 2.2.2 Fully Protected Species.....8

 2.2.3 Native Plant Protection Act.....9

 2.2.4 Porter Cologne Water Quality Control Act.....9

 2.2.5 California Fish and Game Code.....10

 2.2.6 Conservation and Open Space Element.....10

 2.2.7 California Environmental Quality Act Significance Criteria.....10

3.0 METHODS.....11

 3.1 Literature Review.....11

 3.2 Field Survey.....12

 3.2.1 Small Unmanned Aircraft System Survey and Vegetation Mapping.....12

 3.2.2 Biological Reconnaissance Survey.....12

 3.2.3 Aquatic Resources Delineation.....13

 3.3 Potential for Occurrence Determinations.....13

4.0 RESULTS.....14

 4.1 Literature Review.....14

 4.1.1 Special-Status Plants and Wildlife.....14

 4.1.2 U.S. Fish and Wildlife Service Designated Critical Habitat.....14

 4.2 Biological Reconnaissance Survey.....14

 4.2.1 Property Characteristics.....15

 4.2.2 Vegetation Communities/Land Use.....25

 4.2.3 Wildlife Observed.....37

 4.3 Special-Status Species Assessment.....37

 4.3.1 Plants.....37

 4.3.2 Wildlife.....39

4.4 Jurisdictional Aquatic Resources Assessment..... 53

4.5 Wildlife Movement Corridors, Linkages, and Significant Ecological Areas..... 53

5.0 IMPACT ASSESSMENT..... 54

5.1.1 Special-Status Species..... 54

5.1.2 Sensitive Natural Communities..... 56

5.1.3 State- and/or Federally Protected Wetlands and Waters 57

5.1.4 Wildlife Corridors and Nursery Sites..... 57

5.1.5 Habitat and Conservation Plans and Natural Community Conservation..... 57

6.0 RECOMMENDATIONS AND MITIGATION MEASURES..... 57

7.0 CERTIFICATION 60

8.0 REFERENCES..... 61

LIST OF TABLES

Table 1. USGS Quadrangle Information4

Table 2. Weather Conditions During the Survey..... 15

Table 3. Vegetation Communities and Land Covers in Project Area 25

Table 4. CNPS Status Designations 38

Table 5. Wildlife Status Designations 40

LIST OF FIGURES

Figure 1. Project Location and Vicinity5

Figure 2. Site Plan.....6

Figure 3. Natural Resources Conservation Service Soil Types..... 16

Figure 4. Vegetation Communities and Land Cover..... 26

Figure 5. Special-Status Species Observations 42

LIST OF ATTACHMENTS

- Attachment A – Representative Site Photographs
- Attachment B – Special-Status Plant Potential For Occurrence
- Attachment C – Special-Status Wildlife Potential For Occurrence

LIST OF ACRONYMS AND ABBREVIATIONS

AOU	American Ornithologists' Union
CDFW	California Department of Fish and Wildlife
CEQA	California Environmental Quality Act
CFR	Code of Federal Regulations
CNDDDB	California Natural Diversity Data Base
CNPS	California Native Plant Society
CNPSEI	CNPS Electronic Inventory
CWA	Clean Water Act
ESA	Endangered Species Act
GIS	Geographic Information System
GPS	Global Positioning System
HCP	Habitat conservation plan
MBTA	Migratory Bird Treaty Act
MW	Megawatt
MWH	Megawatt-hour
NPPA	Native Plant Protection Act
NRCS	Natural Resources Conservation Service
Project	Vega SES 4 Solar Project
RWQCB	Regional Water Quality Control Board (Colorado River Basin)
SAA	Streambed Alteration Agreement
SSAR	Society for the Study of Amphibians and Reptiles
SSC	Species of Special Concern
sUAS	Small unmanned aircraft system
SWRCB	State Water Resources Control Board
USACE	U.S. Army Corps of Engineers
USEPA	U.S. Environmental Protection Agency
USFWS	U.S. Fish and Wildlife Service
USGS	U.S. Geological Survey

1.0 INTRODUCTION

The Vega SES 4 Solar Project (Project) is a 100-Megawatt (MW) direct current (dc) and 400 MW-hour (MWH) battery storage utility-scale solar project located on approximately ±511.61 acres of vacant land in Imperial County, California (CA). ECORP Consulting, Inc. conducted a literature review, small unmanned aircraft system (sUAS) survey, and biological reconnaissance survey of the Project Area to document the existing biological resources, to assess the habitat for its potential to support sensitive plant and wildlife species, and, as required under the California Environmental Quality Act (CEQA), to determine whether Project-related impacts would occur to sensitive biological resources.

1.1 Purpose of the Report

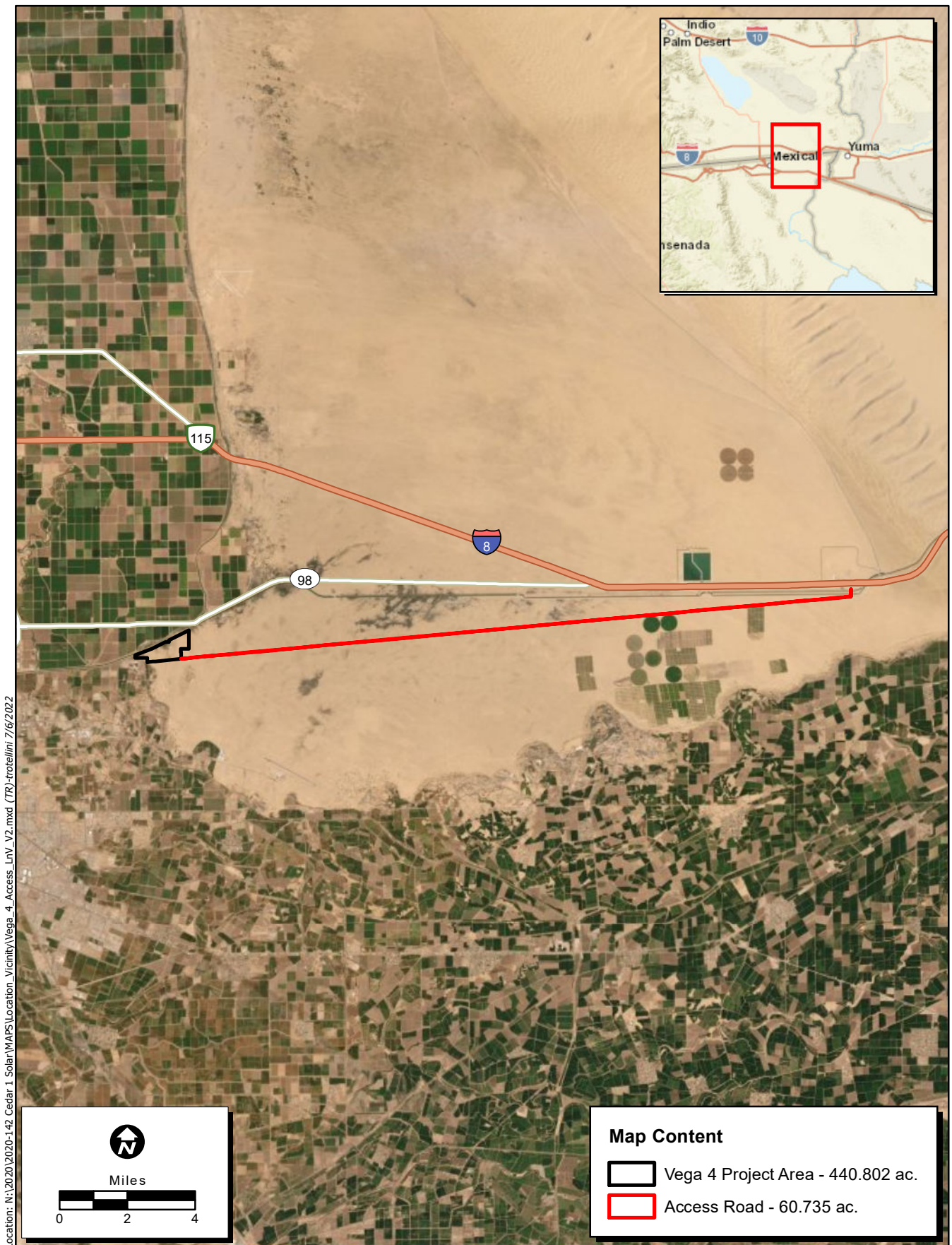
This report was prepared to describe biological resources in the Project and to support Project review under CEQA. Assessment of potential occurrences of special-status plants and animals is based on habitat, geographic and elevational range, and data from field surveys conducted by ECORP in 2020 and 2022. For purposes of this report, the term “Project Area” refers to the solar field and the access road which include areas of permanent impacts. The term “Survey Area” refers to the areas proposed to be directly affected by the Project, the 500-foot buffer, and areas potentially subject to temporary impacts.

1.2 Project Location and Description



The proposed Project includes a 100-MW dc and 400 MWH battery storage utility-scale solar project located on approximately 511.61 acres of vacant land on two parcels in Imperial County, California (Assessor Parcel Numbers 059-300-015 and 059-300-017). An approximately 22-linear-mile access road totaling 61 acres will be used to access the solar site. The Project Area is approximately nine miles southeast of Calexico, California, and ½ mile south of Highway 98. It is adjacent to the All-American Canal to the north and the United States (U.S.)/Mexico border to the south (Figure 1). A complete summary of geographic information for the Study Area is provided in Table 1.

USGS 7.5-Minute Quad Map Name	Township	Range	Section(s)	Approximate Center of Study Area
Bonds Corner, CA (1976) Midway Well NW, CA (1979) Midway Well, CA (1979) Grays Well, CA (1976)	17S	16E 17E 18E 19E 20E	12, 13, 14 7, 8, 9, 10, 11, 12 1, 7, 8, 9, 10, 11, 12 1, 2, 3, 4, 5, 6 1, 6	32.682898, -115.304246



The Project will connect to an Imperial Irrigation District (IID) 92 kilovolt transmission line that runs close to the property. The Project is also currently contemplated to include a potential cross border permit to enable building a transmission line approximately three miles from the proposed site substation across the international border to deliver power to the closest Federal Electricity Commission substation in Mexico (Figure 2).



Location: N:\2020\2020-142_Cedar 1 Solar\WAPS\Location_Vicinity\Vega_4_Access_LnV_V2.mxd (TR)-trotellini 7/6/2022


 Miles


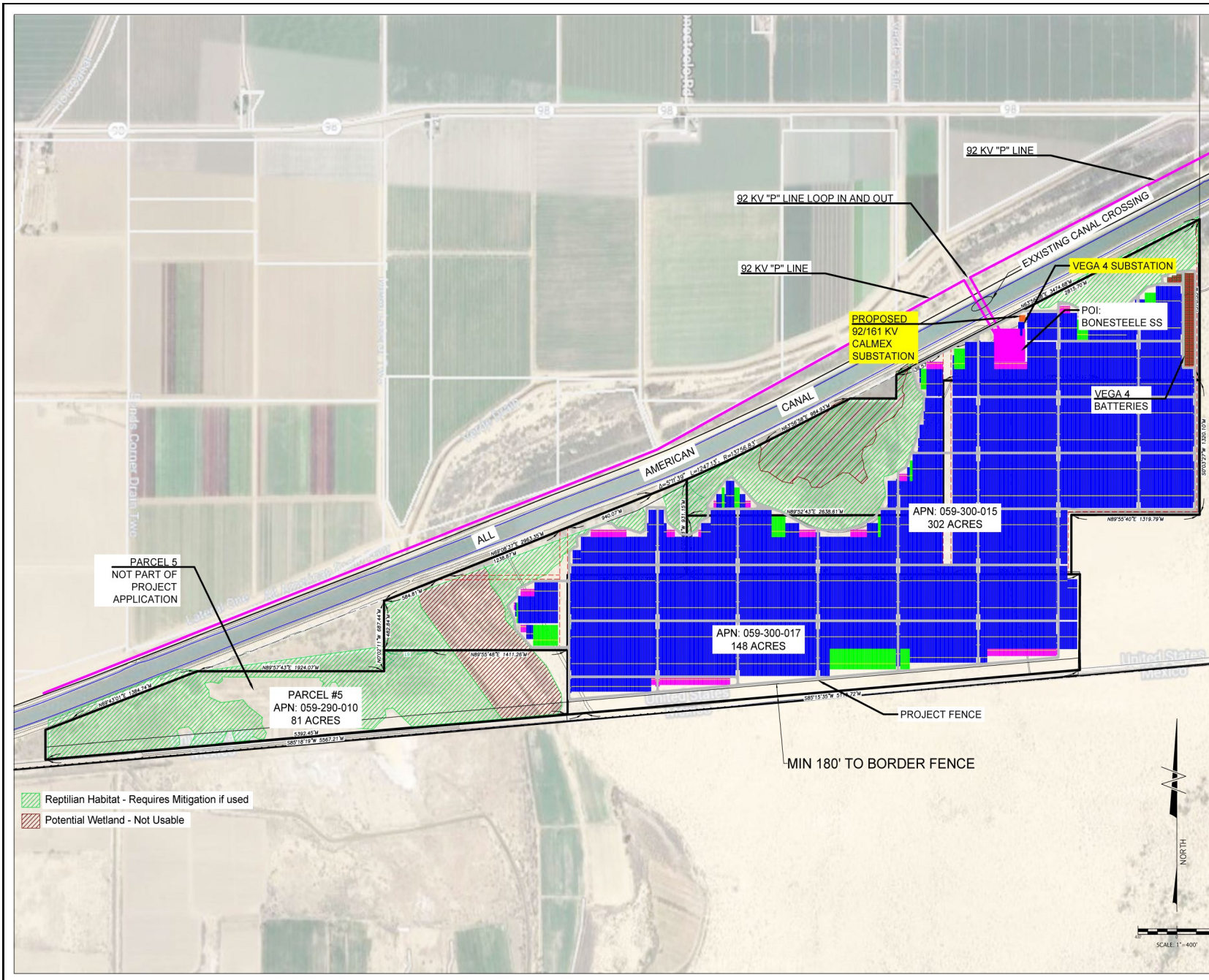
Map Content

-  Vega 4 Project Area - 440.802 ac.
-  Access Road - 60.735 ac.

Map Date: 6/29/2022
 Service Layer Credits: Sources: Esri, HERE, Garmin, USGS, Intermap, INCREMENT P, NRCan, Esri Japan, METI, Esri China (Hong Kong), Esri Korea, Esri (Thailand), NGCC, (c) OpenStreetMap contributors, and the GIS User Community

Figure 1. Project Location and Vicinity

2020-142 Vega SES 4



VEGA 4 SES

CONFIDENTIAL DOCUMENTS
 THE INFORMATION SHOWN ON THIS DRAWING IS STRICTLY CONFIDENTIAL AND IS SUPPLIED WITH THE UNDERSTANDING THAT IT WILL BE HELD CONFIDENTIAL AND NOT DISCLOSED TO THIRD PARTIES WITHOUT THE PRIOR WRITTEN CONSENT OF ZGLOBAL, INC.

REV.	BY	DESCRIPTION	DATE	APPROV BY
0	HP	PRELIMINARY	11/1/21	HP
1	HP	BORDER SETBACK PRELIMINARY	2/28/22	HP
2	HP	VEGA 4 ADJUSTED LAYOUT	05/18/22	HP

1 inch
Scale to Confirm 24"x36" Plot

ZGLOBAL
Power Engineering & Energy Solutions

604 SUTTER ST, STE 250
FOLSOM, CA 95630
Phone : 916.985.9461
Fax : 916.985.9467

THESE DRAWINGS AND SPECIFICATIONS HAVE BEEN PREPARED BY ZGLOBAL, INC. FOR THEIR EXCLUSIVE USE IN ACCORD WITH SEC. 8737.3 OF THE STATE PROFESSIONAL ENGINEERS ACT OF THE STATE OF CALIFORNIA.

SHEET TITLE:

SITE PLAN

DRAWN BY:	RO	DRAWING No:	
CHECKED:	HP		
SCALE:	AS NOTED	C-000	
JOB NO:			
DATE:			
		REV No:	1

Topography is relatively flat with elevations ranging between 11 meters (38 feet) and 48 meters (159 feet) above mean sea level. Adjacent land uses include agricultural and ranch land to the north and west, the U.S./Mexico border to the south, and undeveloped land to the east. The All-American Canal travels northeast to southwest, north of the site. The access road runs east-west directly north and adjacent to the U.S./Mexico border wall.

2.0 REGULATORY CONSIDERATIONS

The biological reconnaissance survey was conducted to identify potential constraints and to ensure compliance with State and federal regulations regarding listed, protected, and sensitive species. The regulations are detailed below.

2.1 Federal Regulations

2.1.1 Endangered Species Act

The Endangered Species Act (ESA) protects plants and animals that are listed as endangered or threatened by the U.S. Fish and Wildlife Service (USFWS) and the National Marine Fisheries Service. Section 9 of the ESA prohibits the taking of endangered wildlife, where taking is defined as “harass, harm, pursue, hunt, shoot, wound, kill, trap, capture, collect, or attempt to engage in such conduct” (50 Code of Federal Regulations [CFR] 17.3). For plants, this statute governs removing, possessing, maliciously damaging, or destroying any endangered plant on federal land and removing, cutting, digging up, damaging, or destroying any endangered plant on non-federal land in knowing violation of state law (16 U.S. Code 1538). Under Section 7 of the ESA, federal agencies are required to consult with the USFWS if their actions, including permit approvals or funding, could adversely affect a listed (or proposed) species (including plants) or its critical habitat. Through consultation and the issuance of a biological opinion, the USFWS may issue an incidental take statement allowing take of the species that is incidental to an otherwise authorized activity provided the activity will not jeopardize the continued existence of the species. Section 10 of the ESA provides for issuance of incidental take permits where no other federal actions are necessary provided a habitat conservation plan (HCP) is developed.

2.1.2 Migratory Bird Treaty Act

The Migratory Bird Treaty Act (MBTA) implements international treaties between the U.S. and other nations devised to protect migratory birds, any of their parts, eggs, and nests from activities such as hunting, pursuing, capturing, killing, selling, and shipping, unless expressly authorized in the regulations or by permit. As authorized by the MBTA, the USFWS issues permits to qualified applicants for the following types of activities: falconry, raptor propagation, scientific collecting, special purposes (rehabilitation, education, migratory game bird propagation, and salvage), take of depredating birds, taxidermy, and waterfowl sale and disposal. The regulations governing migratory bird permits can be found in 50 CFR Part 13 General Permit Procedures and 50 CFR Part 21 Migratory Bird Permits. The State of California has incorporated the protection of birds of prey in Sections 3800, 3513, and 3503.5 of the California Fish and Game Code.

2.1.3 Clean Water Act

The purpose of the Clean Water Act (CWA) is to “restore and maintain the chemical, physical, and biological integrity of the nation’s waters.” Section 404 of the CWA prohibits the discharge of dredged or fill material into Waters of the U.S. without a permit from the U.S. Army Corps of Engineers (USACE). The definition of Waters of the U.S. includes rivers, streams, estuaries, the territorial seas, ponds, lakes, and wetlands. Wetlands are defined as those areas “that are inundated or saturated by surface or ground water at a frequency and duration sufficient to support, and that under normal circumstances do support, a prevalence of vegetation typically adapted for life in saturated soil conditions” (33 CFR 328.3 7b). The U.S. Environmental Protection Agency (USEPA) acts as a cooperating agency to set policy, guidance, and criteria for use in evaluation permit applications and also reviews USACE permit applications.

The USACE regulates “fill” or dredging of fill material within its jurisdictional features. “Fill material” means any material used for the primary purpose of replacing an aquatic area with dry land or changing the bottom elevation of a water body. Substantial impacts to wetlands may require an individual permit. Projects that only minimally affect wetlands may meet the conditions of one of the existing Nationwide Permits. A Water Quality Certification or waiver pursuant to Section 401 of the CWA is required for Section 404 permit actions; this certification or waiver is issued by the State Water Resources Control Board (SWRCB), administered by each of nine California Regional Water Quality Control Boards.

2.2 State and Local Regulations

2.2.1 California Endangered Species Act

The California ESA generally parallels the main provisions of the ESA but, unlike its federal counterpart, the California ESA applies the take prohibitions to species proposed for listing (called “candidates” by the State). Section 2080 of the California Fish and Game Code prohibits the taking, possession, purchase, sale, and import or export of endangered, threatened, or candidate species, unless otherwise authorized by permit or in the regulations. Take is defined in Section 86 of the California Fish and Game Code as “hunt, pursue, catch, capture, or kill, or attempt to hunt, pursue, catch, capture, or kill.” The California ESA allows for take incidental to otherwise lawful development projects. State lead agencies are required to consult with California Department of Fish and Wildlife (CDFW) to ensure that any action they undertake is not likely to jeopardize the continued existence of any endangered or threatened species or result in destruction or adverse modification of essential habitat.

2.2.2 Fully Protected Species

The State of California first began to designate species as “fully protected” prior to the creation of the federal and California ESAs. Lists of fully protected species were initially developed to provide protection to those animals that were rare or faced possible extinction, and included fish, amphibians and reptiles, birds, and mammals. Most fully protected species have since been listed as threatened or endangered under federal and/or California ESAs. The regulations that implement the Fully Protected Species Statute (California Fish and Game Code § 4700) provide that fully protected species may not be taken or

possessed at any time. Furthermore, CDFW prohibits any State agency from issuing incidental take permits for fully protected species, except for necessary scientific research.

2.2.3 Native Plant Protection Act

The Native Plant Protection Act (NPPA) of 1977 (California Fish and Game Code §§ 1900-1913) was created with the intent to “preserve, protect and enhance rare and endangered plants in this State.” The NPPA is administered by CDFW. The Fish and Wildlife Commission has the authority to designate native plants as “endangered” or “rare” and to protect endangered and rare plants from take. The California ESA of 1984 (California Fish and Game Code § 2050-2116) provided further protection for rare and endangered plant species, but the NPPA remains part of the California Fish and Game Code.

2.2.4 Porter Cologne Water Quality Control Act

The RWQCB implements water quality regulations under the federal CWA and the Porter-Cologne Water Quality Act. These regulations require compliance with the National Pollutant Discharge Elimination System (NPDES), including compliance with the California Storm Water NPDES General Construction Permit for discharges of storm water runoff associated with construction activities. General Construction Permits for projects that disturb one or more acres of land require development and implementation of a Storm Water Pollution Prevention Plan. Under the Porter-Cologne Water Quality Act, the RWQCB regulates actions that would involve “discharging waste, or proposing to discharge waste, with any region that could affect the water of the state” [Water Code 13260(a)].

Waters of the State are defined as “any surface water or groundwater, including saline waters, within the boundaries of the state” (Water Code 13050[e]). The RWQCB regulates all such activities, as well as dredging, filling, or discharging materials into Waters of the State that are not regulated by the USACE due to a lack of connectivity with a navigable water body. The RWQCB may require issuance of Waste Discharge Requirements for these activities.

On April 2, 2019, the SWRCB adopted the *State Wetland Definition and Procedures for Discharges of Dredged or Fill Material to Waters of the State* (referred to as the Procedures) for inclusion in the *Water Quality Control Plan for Inland Surface Waters, Enclosed Bays, and Estuaries of California* (Resolution No. 2019-0015). The new Procedures include:

- definition of wetlands and aquatic resources that are Waters of the State,
- description of application requirements for individual orders (not general orders) for water quality certification, or waste discharge requirements,
- description of information required in compensatory mitigation plans, and
- definition of exemptions to application procedures.

The Office of Administrative Law approved the procedures on August 28, 2019, and the rule went into effect May 28, 2020.

2.2.5 California Fish and Game Code

Streambed Alteration Agreement

Section 1602 of the California Fish and Game Code requires that a Notification of Lake or Streambed Alteration be submitted to CDFW for “any activity that may substantially divert or obstruct the natural flow or substantially change the bed, channel, or bank of any river, stream, or lake.” The CDFW reviews the proposed actions and, if necessary, submits to the Applicant a proposal for measures to protect affected fish and wildlife resources. The final proposal that is mutually agreed upon by CDFW and the Applicant is the Streambed Alteration Agreement (SAA). Often, projects that require an SAA also require a permit from the USACE under Section 404 of the CWA. In these instances, the conditions of the Section 404 permit and the SAA may overlap.

Migratory Birds

The CDFW enforces the protection of nongame native birds in §§ 3503, 3503.5, and 3800 of the California Fish and Game Code. Section 3513 of the California Fish and Game Code prohibits the possession or take of birds listed under the MBTA. These sections mandate the protection of California nongame native birds’ nests and also make it unlawful to take these birds. All raptor species are protected from “take” pursuant to California Fish and Game Code § 3503.5 and are also protected at the federal level by the MBTA of 1918 (USFWS 1918).

2.2.6 Conservation and Open Space Element

Imperial County created the Conservation and Open Space Element plan to provide details and measures for management and preservation of biological resources as well as various other resources (i.e. cultural, soils, minerals, etc.). This plan focuses on protecting scarce resources and preventing wasteful exploitation, neglect, and destruction of California’s natural resources. The plan outlines areas with sensitive habitat and sensitive species, also labelled “Resource Areas”. Open space easements and protection of riparian habitat, rock outcrops, California fan palm oases, and wildlife corridors are also discussed in the plan. As it currently stands, the open space element follows CEQA guidelines with special focus on its scarce resources.

2.2.7 California Environmental Quality Act Significance Criteria

Section 15064.7 of the CEQA Guidelines encourages local agencies to develop and publish the thresholds the agency uses in determining the significance of environmental effects caused by projects under its review. However, agencies may also rely upon the guidance provided by the expanded Initial Study checklist contained in Appendix G of the CEQA Guidelines. Appendix G provides examples of impacts that would normally be considered significant. Based on these examples, impacts to biological resources would normally be considered significant if the project would:

- have a substantial adverse effect, either directly or through habitat modifications, on any species identified as a candidate, sensitive, or special status species in local or regional plans, policies, or regulations, or by CDFW or USFWS;

- have a substantial adverse effect on any riparian habitat or other sensitive natural community identified in local or regional plans, policies, regulations or by CDFW or USFWS;
- have a substantial adverse effect on State or federally protected wetlands (including, but not limited to, marsh, vernal pool, and coastal) through direct removal, filling, hydrological interruption, or other means;
- interfere substantially with the movement of any native resident or migratory fish or wildlife species, or with established native resident or migratory wildlife corridors, or impede the use of native wildlife nursery sites;
- conflict with any local policies or ordinances protecting biological resources, such as a tree preservation policy or ordinance; and
- conflict with the provisions of an adopted HCP, Natural Community Conservation Plan, or other approved local, regional, or State HCP.

An evaluation of whether an impact on biological resources would be substantial must consider both the resource itself and how that resource fits into a regional or local context. Substantial impacts would be those that would diminish, or result in the loss of, an important biological resource, or those that would obviously conflict with local, State, or federal resource conservation plans, goals, or regulations. Impacts are sometimes locally important but not significant according to CEQA. The reason for this is that although the impacts would result in an adverse alteration of existing conditions, they would not substantially diminish, or result in the permanent loss of an important resource on a population-wide or region-wide basis.

3.0 METHODS

3.1 Literature Review

Prior to conducting the biological reconnaissance survey, ECORP biologists performed a literature review using the CDFW's California Natural Diversity Data Base (CNDDDB; CDFW 2022a) and the California Native Plant Society's (CNPS') Electronic Inventory (CNPSEI; CNPS 2022) to determine the special-status plant and wildlife species that have been documented in the vicinity of the Project. The CNDDDB and CNPSEI database searches were initially conducted on September 24, 2020, and an updated literature search was performed again on April 5, 2022. ECORP searched CNDDDB and CNPSEI records within the Project Area boundaries as depicted on USGS 7.5-minute Bonds Corner, Midway Well NW, Midway Well, and Grays Well, and the surrounding topographic quadrangles: Grays Well NE, Ogilby, Cactus, Glamis SE, Glamis SW, Holtville East, Holtville West, and Calexico. The CNDDDB and CNPSEI contain records of reported occurrences of federally or state-listed endangered, threatened, proposed endangered or threatened species, California Species of Special Concern (SSC), and other special-status species or habitat that may occur within or in the vicinity of the Project. Additional information was gathered from the following sources and includes, but is not limited to:

- U.S. Department of Agriculture, Natural Resources Conservation Service (NRCS) *Web Soil Survey* (NRCS 2022a);
- *Special Animals List* (CDFW 2022b);
- *State and Federally Listed Endangered and Threatened Animals of California* (CDFW 2022c);
- *The Jepson Manual: Vascular Plants of California* (Baldwin et al. 2012);
- *The Manual of California Vegetation*, 2nd Edition (Sawyer et al. 2009); and
- various online websites (e.g., CalFlora 2022).

A desktop review of the National Wetlands Inventory (USFWS 2022a) and the corresponding USGS topographic maps was also conducted to determine if there were any blue line streams or drainages in the Survey Area that might potentially fall under the jurisdiction of either federal or State agencies.

3.2 Field Survey

3.2.1 Small Unmanned Aircraft System Survey and Vegetation Mapping

Due to the size of the area and limited road access, an initial survey utilizing a sUAS was conducted to quickly assess current solar field site conditions and gather high-resolution imagery. Upon arrival at the site, an initial field reconnaissance was conducted by the drone pilot to obtain an understanding of the site topography, access, vegetation densities, and staging areas for controlling the aerial flights. The drone was programmed to do a systematic flight over the property to collect high-resolution aerial photographs of the entire property. The photos collected were then combined into a single orthomosaic image that was incorporated into mapping files in a Geographic Information System (GIS).

The information gathered from the sUAS/drone survey were then used to assist the biologists with accurate mapping of the vegetation communities. A botanist utilized the high-resolution drone imagery to map vegetation communities. Vegetation classifications were in accordance with *A Manual of California Vegetation* (Sawyer et al. 2009). Vegetation communities that did not fit within the Sawyer classification system were described following Holland (1986) or Oberbauer (2008). Areas of the site that had already been graded, developed, and/or disturbed were mapped as such. Acreages of each vegetation community were calculated based on GIS data collected during the sUAS survey.

3.2.2 Biological Reconnaissance Survey

The biological reconnaissance survey was conducted by walking the entire Survey Area to determine the vegetation communities and wildlife habitats present within the Survey Area. Private property and inaccessible areas within the buffer were surveyed utilizing 8x42 binoculars. The biologists documented the plant and animal species present in the Survey Area and the conditions within the Survey Area were assessed for their potential to provide habitat for special-status plant and wildlife species, including those from the literature review. Data were recorded on submeter Global Positioning System (GPS) devices, data

sheets, and maps. In instances where a special-status species was observed, the date, species, location and habitat, and GPS coordinates were recorded. The locations of special-status species observations were recorded using a handheld submeter GPS in North American Datum (NAD) 83, Universal Transverse Mercator (UTM) coordinates, Zone 11S. Photographs were also taken during the survey to provide visual representation of the various vegetation communities within the Survey Area. The Survey Area was also examined to assess its potential to facilitate wildlife movement or function as a movement corridor for wildlife throughout the region.

Plant and wildlife species, including any special-status species that were observed during the survey, were recorded. Plant nomenclature follows that of *The Jepson Manual: Vascular Plants of California* (Baldwin et al. 2012). Wildlife nomenclature follows that of *The American Ornithologists' Union (AOU) Checklist of North American Birds* (AOU 2022), the Society for the Study of Amphibians and Reptiles (SSAR 2017), and the *Revised Checklist of North American Mammals North of Mexico* (Bradley et al. 2014).

3.2.3 Aquatic Resources Delineation

An aquatic resources delineation was conducted by ECORP delineation specialists in conjunction with the biological reconnaissance survey, the results of which are presented under separate cover (ECORP 2022).

3.3 Potential for Occurrence Determinations

Using information from the literature review and observations in the field, a list of special-status plant and animal species that have potential to occur within the Survey Area was generated. For the purposes of this assessment, special-status species are defined as plants or animals that:

- have been designated as either rare, threatened, or endangered by CDFW, CNPS, or the USFWS, and/or are protected under either the federal or California ESAs;
- are candidate species being considered or proposed for listing under these same acts;
- are fully protected by the California Fish and Game Code, §§ 3511, 4700, 5050, or 5515; and
- are of expressed concern to resource and regulatory agencies or local jurisdictions.

Special-status species reported for the region in the literature review or for which suitable habitat occurs on the Survey Area were assessed for their potential to occur within the Survey Area based on the following guidelines:

Present: The species was observed on site during a site visit or focused survey.

High: Habitat (including soils and elevation factors) for the species occurs within the Survey Area and a known occurrence has recently been recorded (within the last 20 years) within five miles of the area.

Moderate: Habitat (including soils and elevation factors) for the species occurs within the Survey Area and a documented observation occurs within the database search, but not within five miles of the area; a

historic documented observation (more than 20 years old) was recorded within five miles of the Survey Area; or a recently documented observation occurs within five miles of the area and marginal or limited amounts of habitat occurs in the Project Area.

Low: Limited or marginal habitat for the species occurs within the Survey Area and a recently documented observation occurs within the database search, but not within five miles of the area; a historic documented observation (more than 20 years old) was recorded within five miles of the Survey Area; or suitable habitat strongly associated with the species occurs on site, but no records or only historic records were found within the database search.

Presumed Absent: Species was not observed during a site visit or focused surveys conducted in accordance with protocol guidelines at an appropriate time for identification; habitat (including soils and elevation factors) does not exist on site; or the known geographic range of the species does not include the Survey Area.

Note: Location information on some special-status species may be of questionable accuracy or unavailable. Therefore, for survey purposes, the environmental factors associated with a species' occurrence requirements may be considered sufficient reason to give a species a positive potential for occurrence. In addition, just because a record of a species does not exist in the databases does not mean it does not occur. In many cases, records may not be present in the databases because an area has not been surveyed for that particular species.

4.0 RESULTS

Summarized below are the results of the literature review and field surveys, including site characteristics, vegetation communities, wildlife, special-status species, and special-status habitats (including any potential wildlife corridors).

4.1 Literature Review

4.1.1 *Special-Status Plants and Wildlife*

Special-status plants and wildlife species reported for the region in the literature review or for which suitable habitat occurs were evaluated for their potential to occur within the Project Area or in the buffer areas within the Survey Area where indirect impacts could occur. Of all available records, a total of 14 special-status plant species and 21 special-status wildlife species were identified as having the potential for occurrence in the vicinity of the Project Area (Attachments B and C).

4.1.2 *U.S. Fish and Wildlife Service Designated Critical Habitat*

The Project Area is not located within any USFWS designated critical habitat.

4.2 Biological Reconnaissance Survey

The biological reconnaissance survey for the solar field was conducted on September 28, 2020, by ECORP biologists Christina Congedo, Greg Hampton, Caroline Garcia, and Christina Torres. The biological

reconnaissance survey for the access road was conducted on April 12 and 13, 2022, by ECORP biologists Caroline Garcia and Christina Torres. Summarized below are the results of the biological reconnaissance survey, including site characteristics, plants and plant communities, wildlife, special-status species, and special-status habitats (including any potential wildlife corridors). Weather conditions during the surveys are summarized in Table 2.

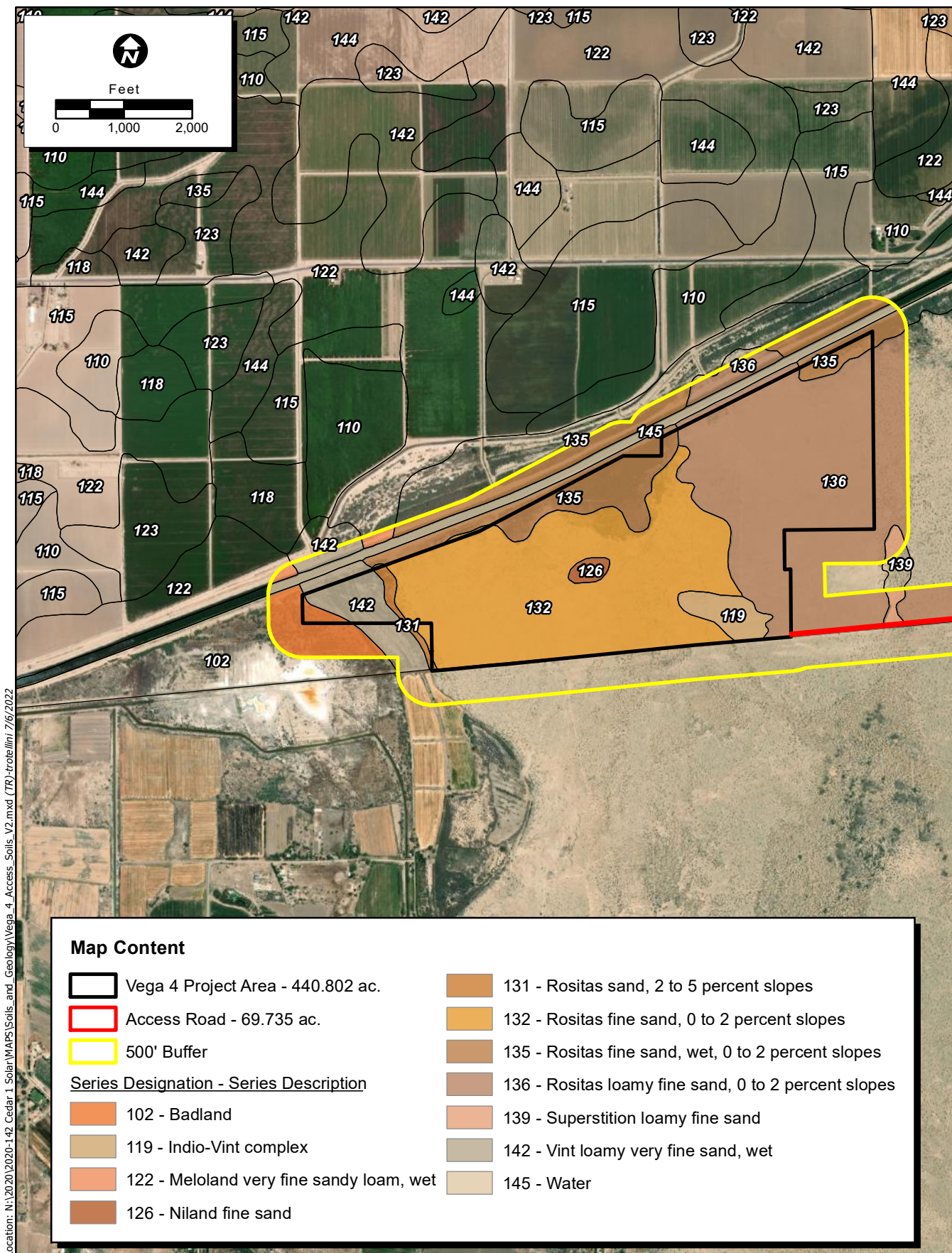
Date	Time		Temperature (°F)		Cloud Cover (%)		Wind Speed (mph)	
	Start	End	Start	End	Start	End	Start	End
9/28/2020	0715	1615	67	102	0	0	0-3	0-5
4/12/2022	0915	1650	63	73	15	3	13-18	0-12
4/13/2022	0830	1620	60	76	0	3	3-7	0-2

4.2.1 Property Characteristics

The Project Area consists of undeveloped land that appears to have been historically altered. The disturbed nature of the site, including flora composition, old agricultural foundations, and farming equipment including a center-pivot irrigation system, indicates that portions of the land may have been historically used for agricultural purposes. The eastern portion of the site consists primarily of creosote bush scrub with bordering riparian scrub and wetland habitats in the northwestern section. The Project Area is surrounded to the north and southwest by agricultural fields, and undeveloped land to the east and southeast. The All-American Canal is just north of the site and the U.S./Mexico border is located just south of the site. The access road runs east-west directly north and adjacent to the U.S./Mexico border wall. A bridge at Gordon Wells Road crosses an offline storage canal of the All-American Canal and the All-American Canal itself and connects to the 22-mile access road. Representative site photographs are included in Attachment A.

Topography throughout the Project Area is relatively flat with a matrix of subtle depressions located in the western section of the site. These depressions consist of an expansive riparian scrub community with associated wetlands and drainages. A soils analysis search was conducted using NRCS soil survey data (NRCS 2022a). Twelve soil series occur within the Project Area (Figure 3). These include:

- 102- Badland
- 111- Holtville-Imperial silty clay loams
- 119- Indio-Vint complex
- 126- Niland fine sand
- 131- Rositas sand, 2 to 5 percent slopes
- 132- Rositas fine sand, 0 to 2 percent slopes



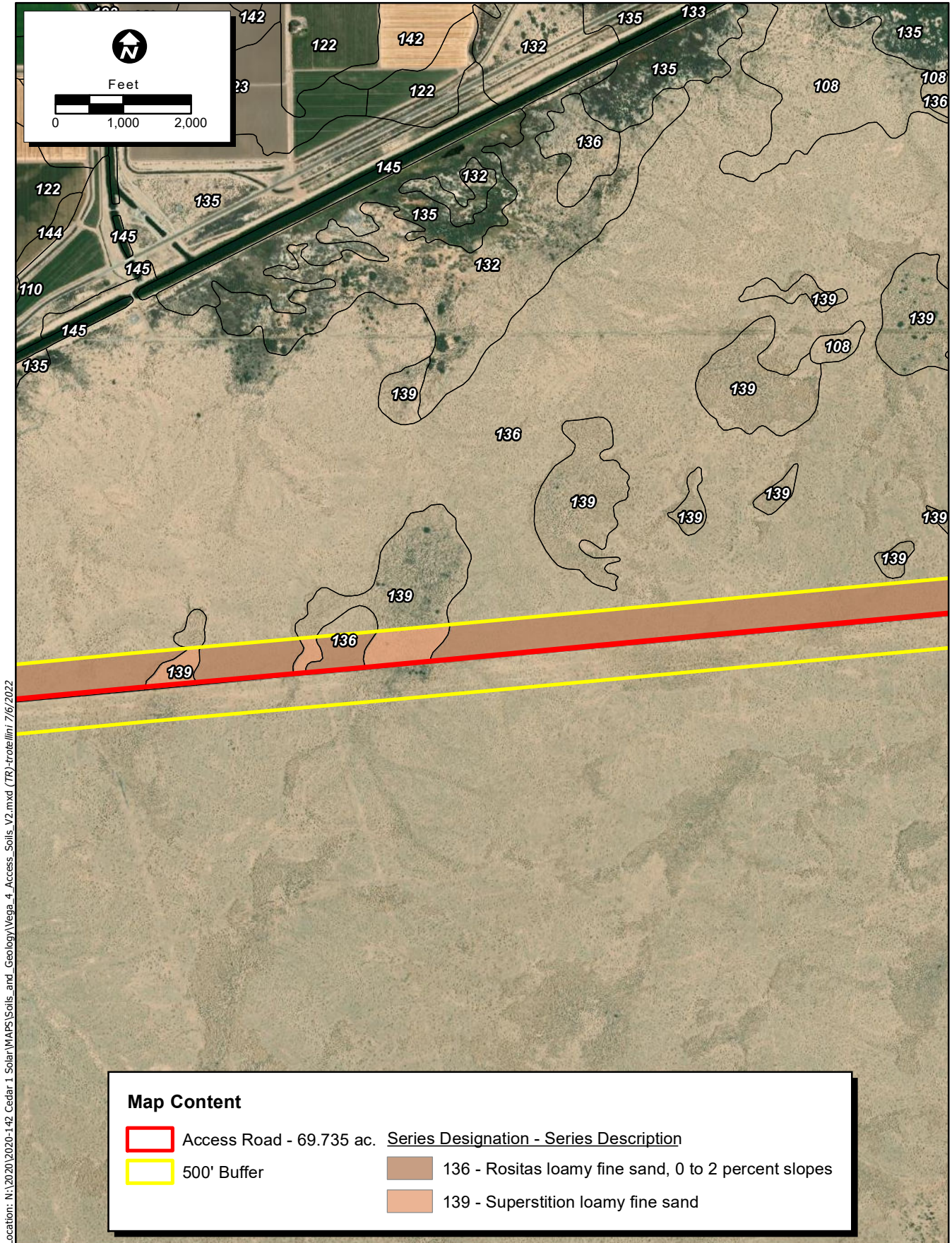
Location: N:\2020\2020-142_Cedar_1_Solar\WAPS\Soils_and_Geology\Vega_4_Access_Soils_V2.mxd (TR)-frote\liri 7/6/2022

Map Date: 7/6/2022

Service Layer Credits: Source: Esri, Maxar, Earthstar Geographic, and the GIS User Community

Figure 3. Natural Resources Conservation Service Soil Types - Sheet 1 of 9

2020-142 Vega SES 4



Location: N:\2020\2020-142_Cedar 1 Solar\WAPS\Soils_and_Geology\Vega_4_Access_Soils_V2.mxd (TR)-frote\lini 7/6/2022

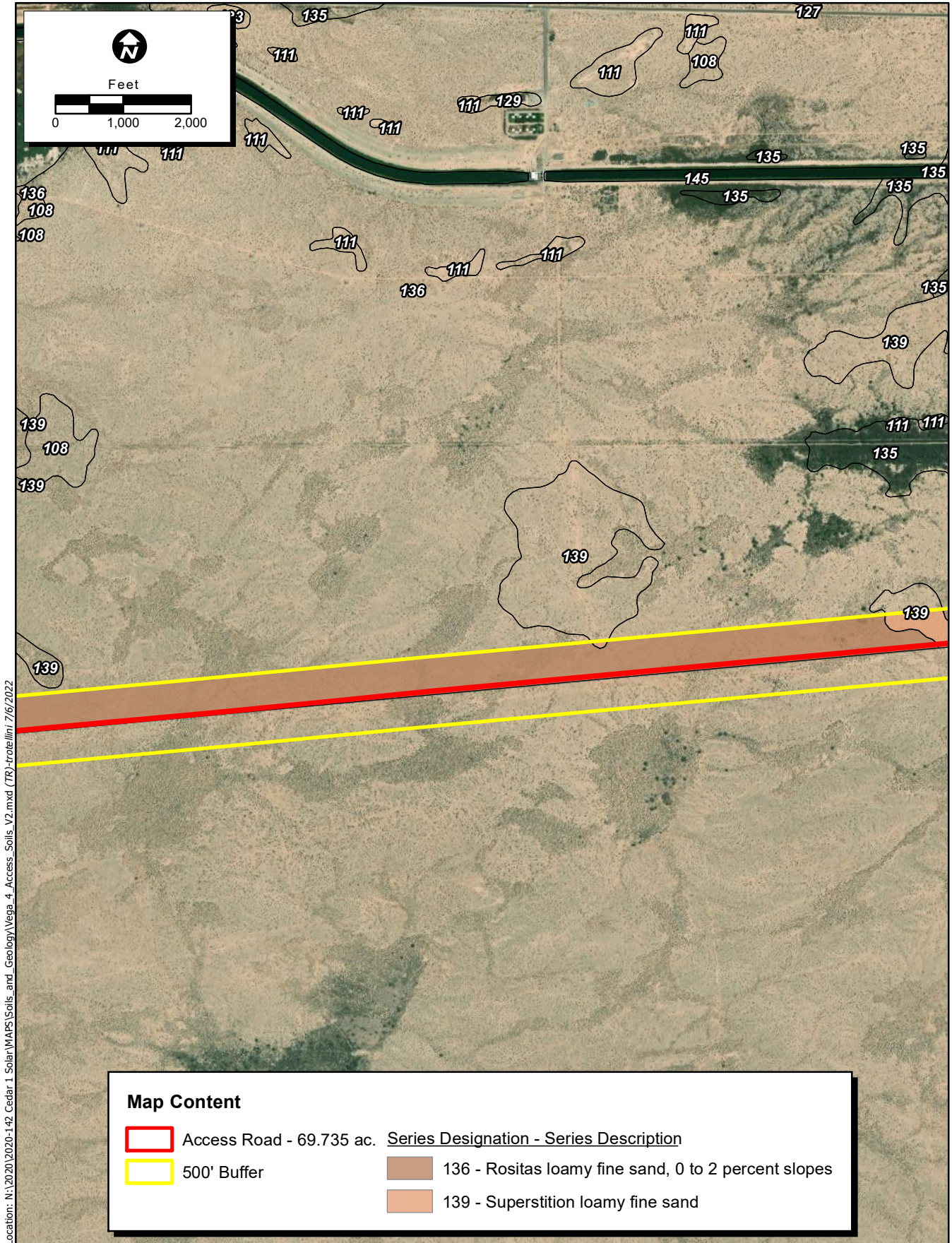
Map Content	
	Access Road - 69.735 ac. <u>Series Designation - Series Description</u>
	500' Buffer
	136 - Rositas loamy fine sand, 0 to 2 percent slopes
	139 - Superstition loamy fine sand

Map Date: 7/6/2022

Service Layer Credits: Source: Esri, Maxar, Earthstar Geographics, and the GIS User Community

Figure 3. Natural Resources Conservation Service Soil Types - Sheet 2 of 9

2020-142 Vega SES 4



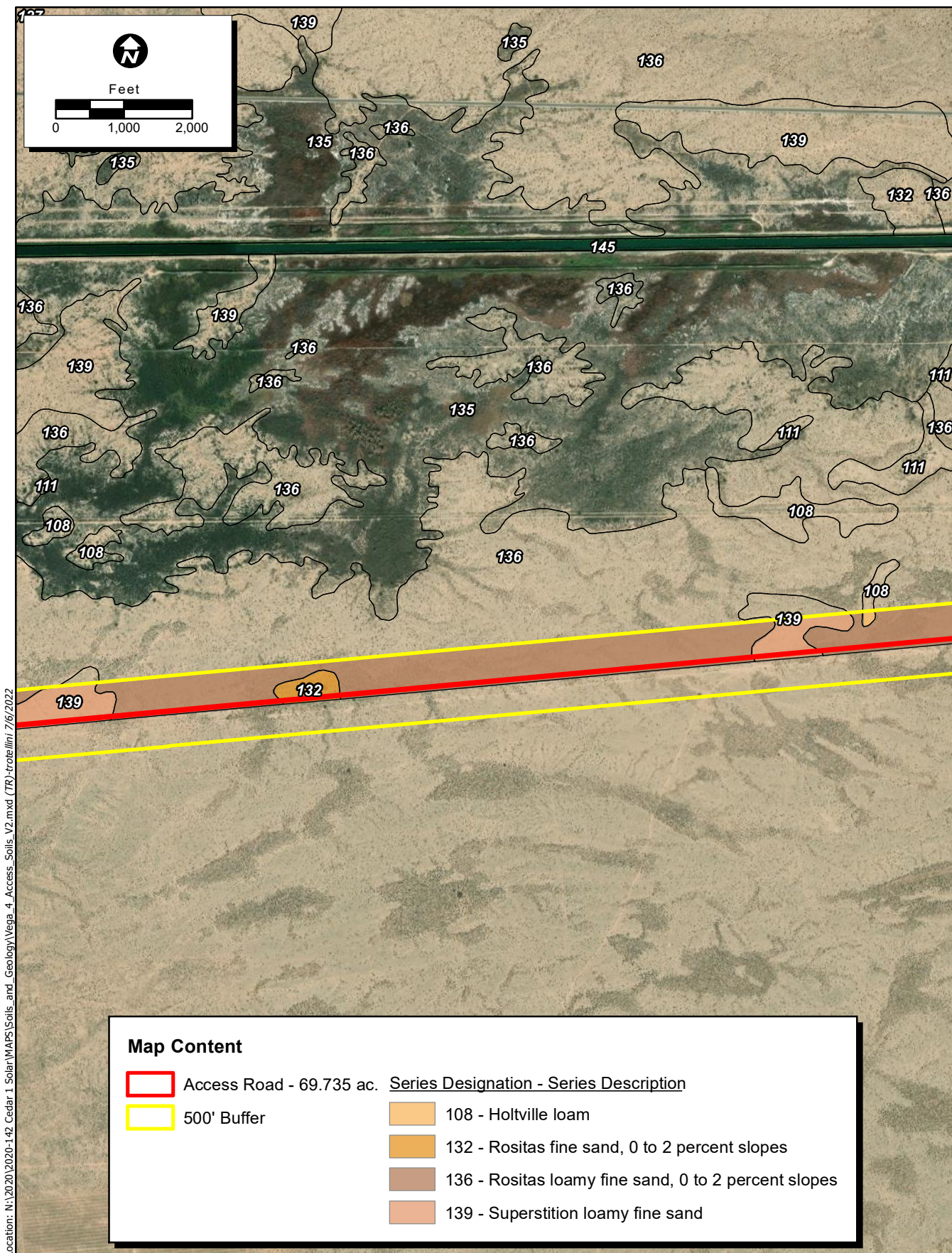
Location: N:\2020\2020-142_Cedar 1 Solar\WAPS\Soils_and_Geology\Vega_4_Access_Soils_V2.mxd (TR)-tr06/lini 7/16/2022

Map Date: 7/6/2022

Service Layer Credits: Source: Esri, Maxar, Earthstar Geographics, and the GIS User Community

Figure 3. Natural Resources Conservation Service Soil Types - Sheet 3 of 9

2020-142 Vega SES 4



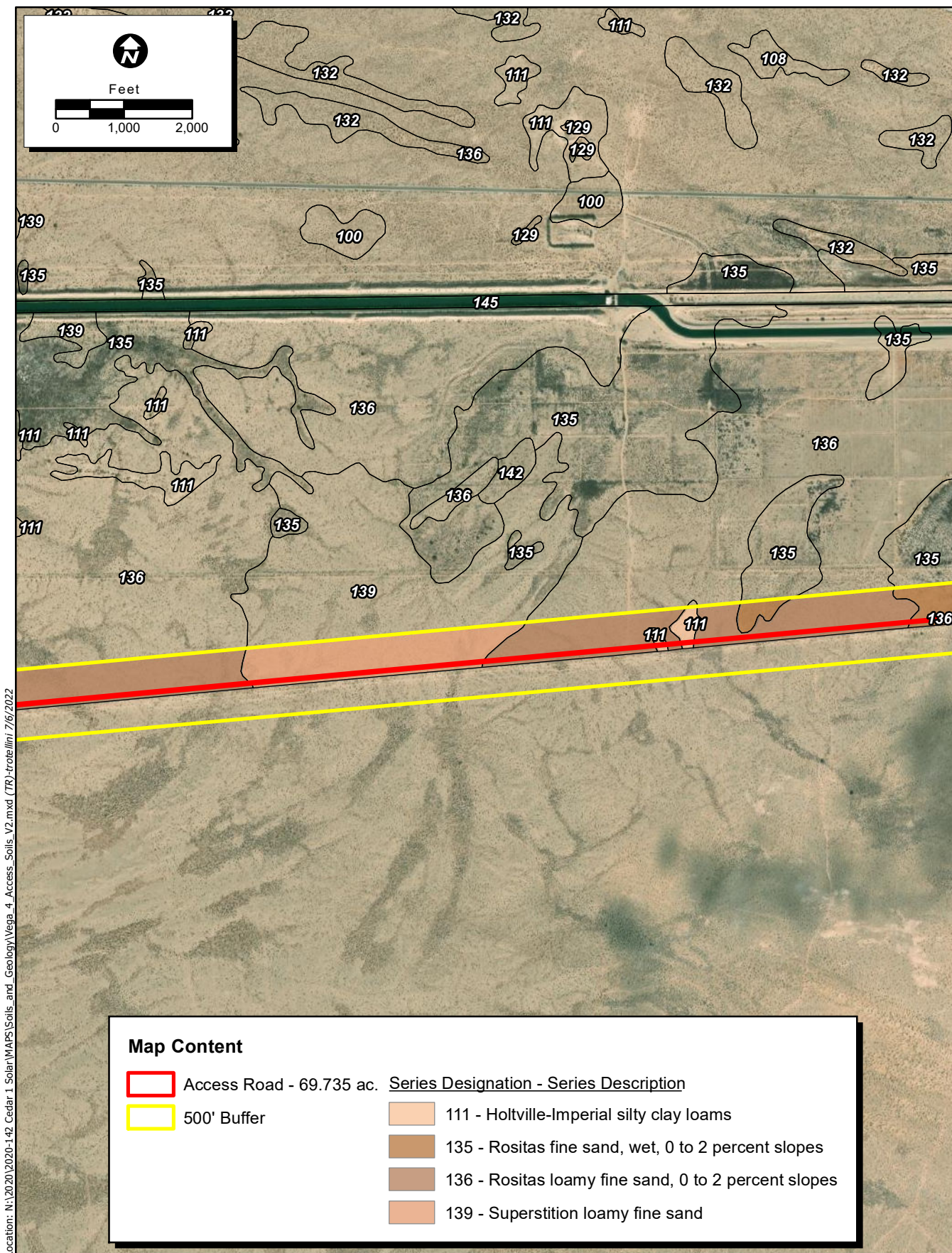
Location: N:\2020\2020-142_Cedar 1 Solar\WAPS\Soils_and_Geology\Vega_4_Access_Soils_V2.mxd (TR)-tr06/lini 7/6/2022

Map Date: 7/6/2022

Service Layer Credits: Source: Esri, Maxar, Earthstar Geographics, and the GIS User Community

Figure 3. Natural Resources Conservation Service Soil Types - Sheet 4 of 9

2020-142 Vega SES 4



Location: N:\2020\2020-142_Cedar 1 Solar\WAPS\Soils_and_Geology\Vega_4_Access_Soils_V2.mxd (TR)-frote\lini 7/6/2022

Map Content		Series Designation - Series Description	
	Access Road - 69.735 ac.		111 - Holtville-Imperial silty clay loams
	500' Buffer		135 - Rositas fine sand, wet, 0 to 2 percent slopes
			136 - Rositas loamy fine sand, 0 to 2 percent slopes
			139 - Superstition loamy fine sand

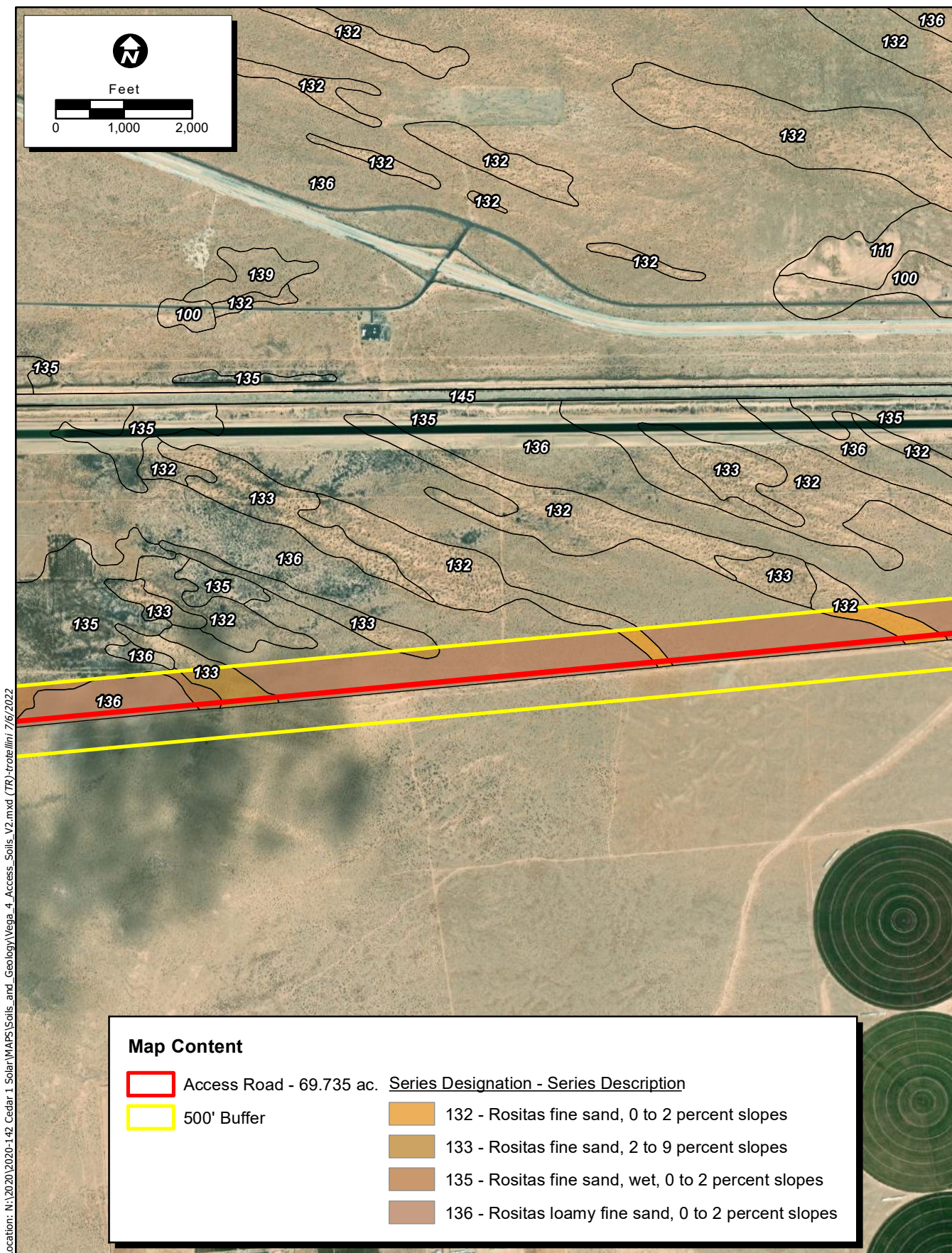
Map Date: 7/6/2022
 Service Layer Credits: Source: Esri, Maxar, Earthstar Geographics, and the GIS User Community

Figure 3. Natural Resources Conservation Service Soil Types - Sheet 5 of 9

2020-142 Vega SES 4



PC ORIGINAL PKG



Location: N:\2020\2020-142_Cedar 1 Solar\WAPS\Soils_and_Geology\Vega_4_Access_Soils_V2.mxd (TR)-frote\lini 7/6/2022

Map Content		Series Designation - Series Description	
	Access Road - 69.735 ac.		132 - Rositas fine sand, 0 to 2 percent slopes
	500' Buffer		133 - Rositas fine sand, 2 to 9 percent slopes
			135 - Rositas fine sand, wet, 0 to 2 percent slopes
			136 - Rositas loamy fine sand, 0 to 2 percent slopes

Map Date: 7/6/2022

Service Layer Credits: Source: Esri, Maxar, Earthstar Geographics, and the GIS User Community

Figure 3. Natural Resources Conservation Service Soil Types - Sheet 6 of 9

2020-142 Vega SES 4



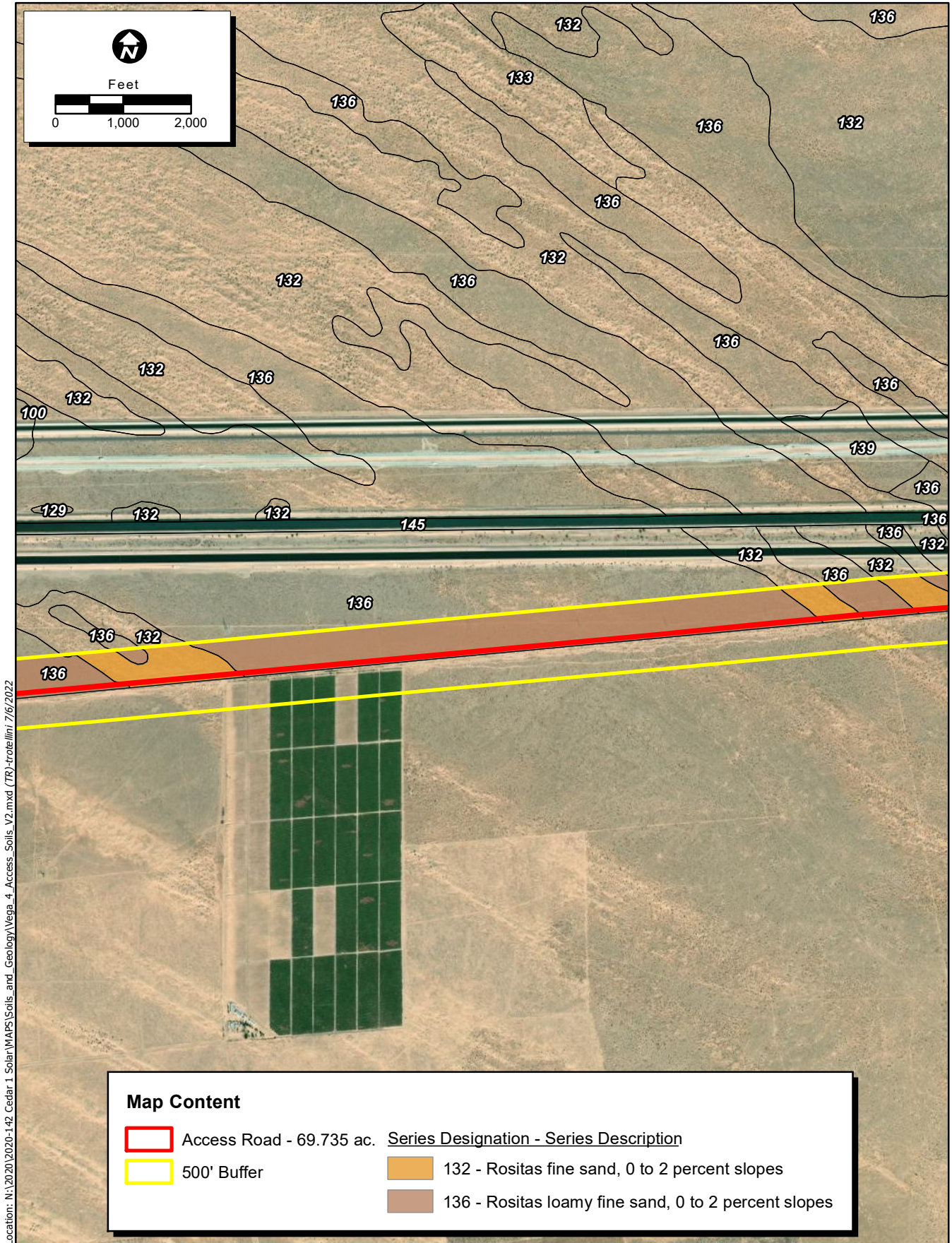
Location: N:\2020\2020-142_Cedar_1_Solar\WAPS\Soils_and_Geology\Vega_4_Access_Soils_V2.mxd (TR)-frote\lini 7/6/2022

Map Date: 7/6/2022

Service Layer Credits: Source: Esri, Maxar, Earthstar Geographics, and the GIS User Community

Figure 3. Natural Resources Conservation Service Soil Types - Sheet 7 of 9

2020-142 Vega SES 4



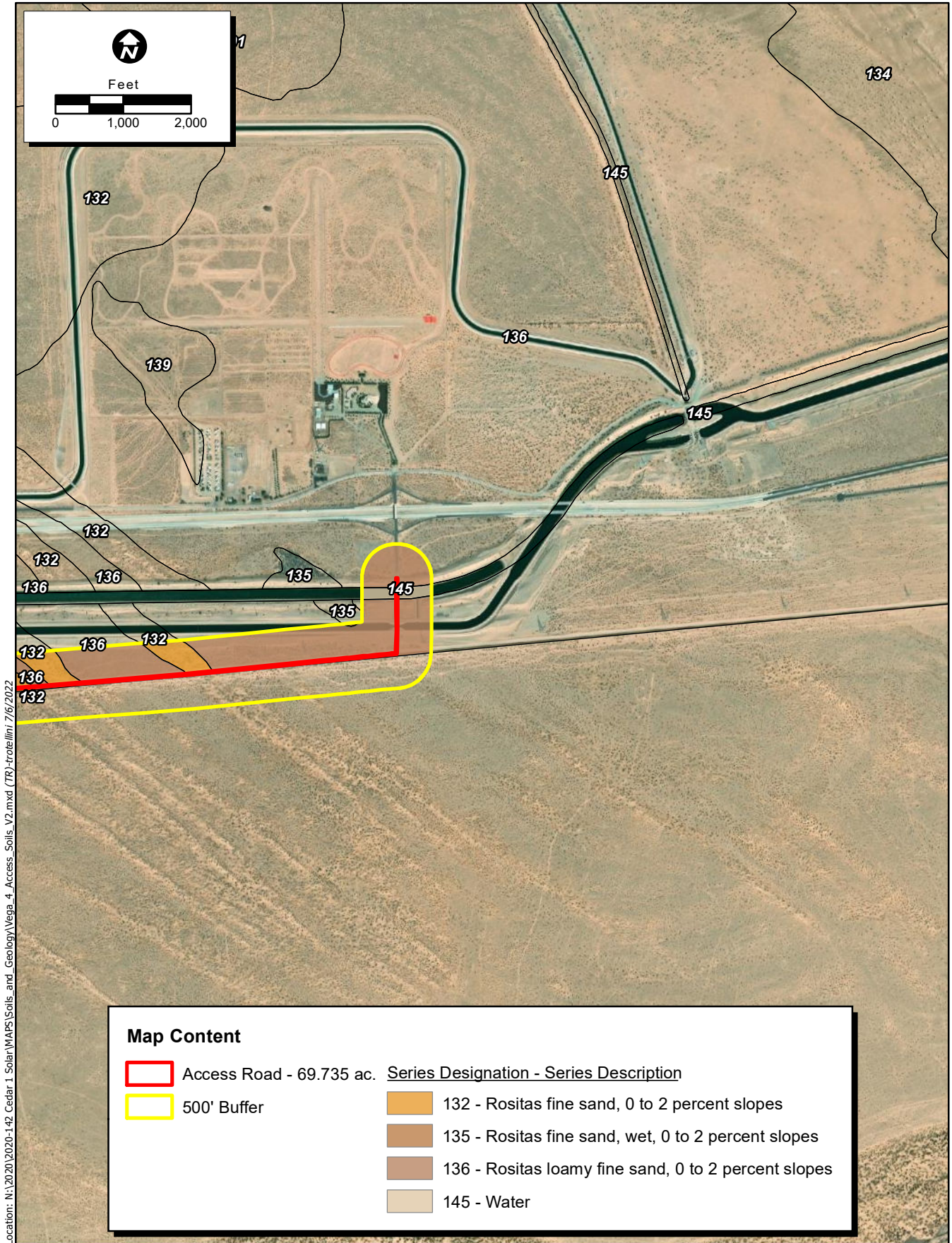
Location: N:\2020\2020-142_Cedar 1 Solar\WAPS\Soils_and_Geology\Vega_4_Access_Soils_V2.mxd (TR)-frote\liri 7/6/2022

Map Date: 7/6/2022

Service Layer Credits: Source: Esri, Maxar, Earthstar Geographics, and the GIS User Community

Figure 3. Natural Resources Conservation Service Soil Types - Sheet 8 of 9

2020-142 Vega SES 4



Location: N:\2020\2020-142_Cedar 1 Solar\WAPS\Soils_and_Geology\Vega_4_Access_Soils_V2.mxd (TR)-frote\lini 7/6/2022

Map Date: 7/6/2022

Service Layer Credits: Source: Esri, Maxar, Earthstar Geographics, and the GIS User Community

Figure 3. Natural Resources Conservation Service Soil Types - Sheet 9 of 9

2020-142 Vega SES 4

- 133- Rositas fine sand, 2 to 9 percent slopes
- 135- Rositas fine sand, wet, 0 to 2 percent slopes
- 136- Rositas loamy fine sand, 0 to 2 percent slopes
- 139- Superstition loamy fine sand
- 142- Vint loamy very fine sand, wet
- 145- Water

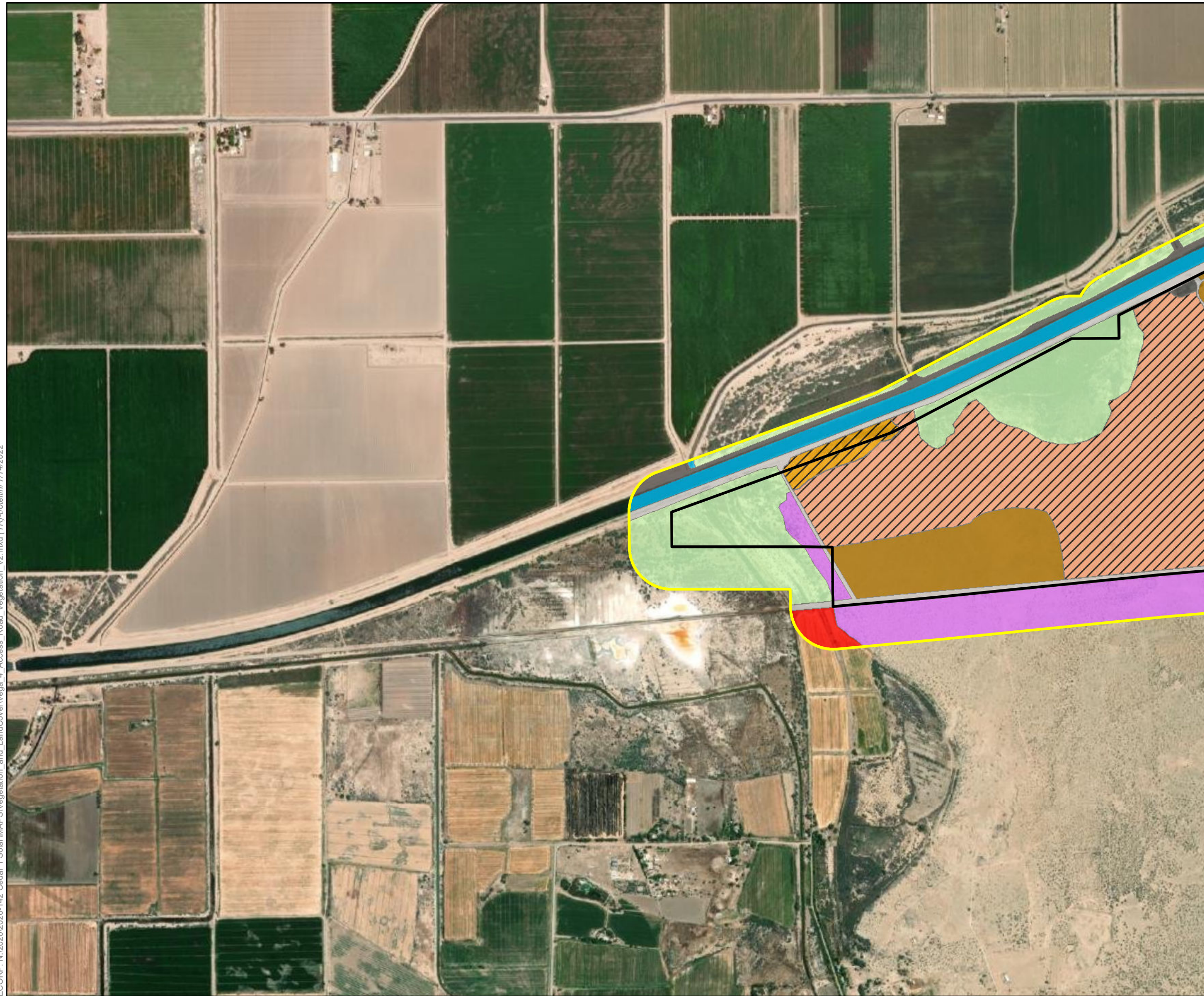
None of the aforementioned soil types contain hydric components (NRCS 2022b). Badland soils are restricted to the western portion of the site and are characterized by high runoff. Indio-Vint complex soils are restricted to the southeastern portion of the site and are characterized as having well-drained soils with low to very low surface runoff. Niland fine sand soils exist in the eastern portion of the site and are characterized as having moderately well-drained soils with low surface runoff. The Rositas series exists throughout the Project Area and is characterized as having somewhat excessively drained soils with very low surface runoff. Vint loamy very fine sand exists in the western portion of the site and is characterized as having moderately well-drained soils with very low surface runoff. Superstition loamy fine sand occurs along the access road and is characterized as having somewhat excessively drained soils. Three additional soil series occur within the survey buffer: Meloland very fine sandy loam (wet) and Holtville loam.

4.2.2 Vegetation Communities/Land Use

The majority of the Project Area consists of creosote bush – white bursage scrub (disturbed), disturbed lands, and tamarisk thickets. The location of each vegetation community in the Project Area and Survey Area are described in detail below and presented on Figure 4. Acreages of each habitat and vegetation community in the Project Area (excluding the buffer area) are shown in Table 3. Representative photographs of the habitats within the Project Area are included in Attachment A.

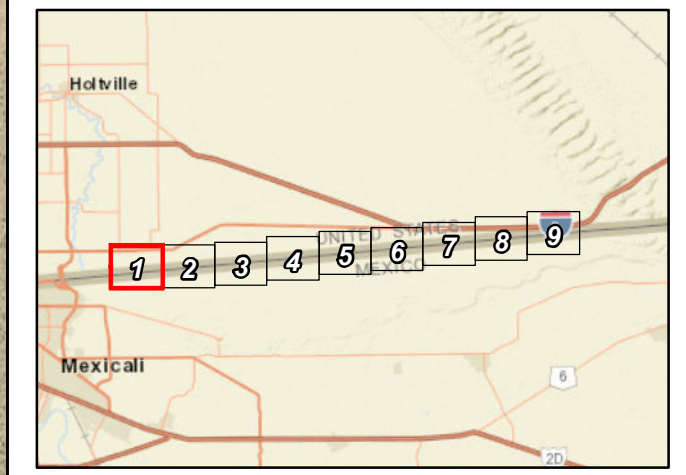
Vegetation Communities and Land Covers	Acres
Arrow weed thickets (disturbed)	10.41
Creosote bush scrub	9.45
Creosote bush – white bursage scrub (disturbed)	181.56
Disturbed	159.73
Tamarisk thickets	66.28
Urban/Developed	0.75
Urban/Developed – Roads	73.37
Project Area Total	501.55

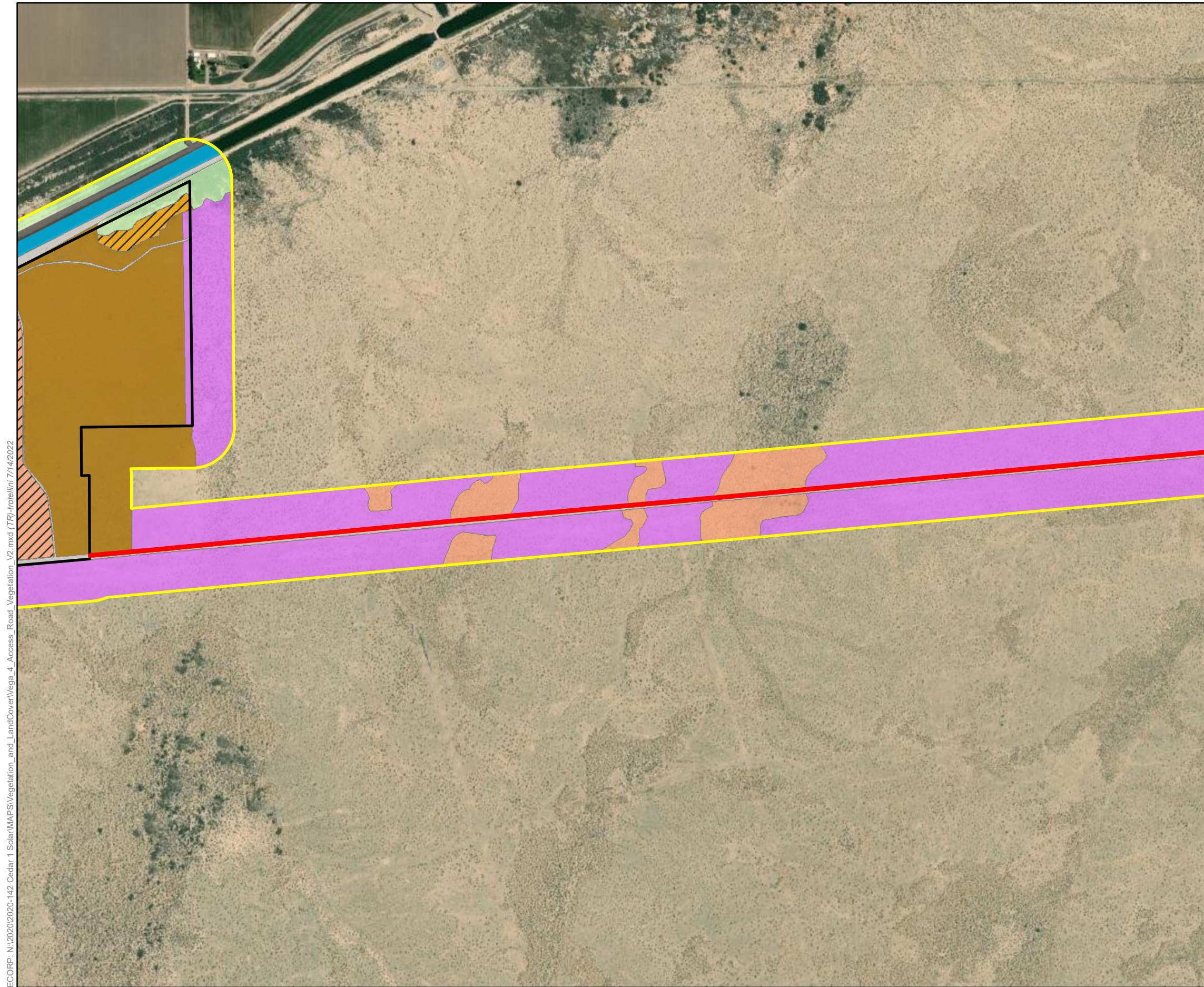
ECORP: N:\2020\2020-142 Cedar 1 Solar\MAPS\Vegetation and LandCover\Vega 4 - Access_Road_Vegetation_V2.mxd (TR)-itolini 7/14/2022



- Map Features**
- Vega 4 Project Area - 440.802
 - 500' Buffer
- Vegetation Communities and Land Cover Types**
- Active Agriculture
 - Channel
 - Creosote Bush Scrub
 - Disturbed Creosote-White Bursage Scrub
 - Disturbed
 - Disturbed Arrow Weed Thickets
 - Tamarisk Thickets
 - Urban/Developed
 - Urban/Developed - Dirt Road

Service Layer Credits: Sources: Esri, HERE, Garmin, USGS, Intermap, INCREMENT P, NRCan, Esri Japan, METI, Esri China (Hong Kong), Esri Korea, Esri (Thailand), NGCC, (c) OpenStreetMap contributors, and the GIS User Community

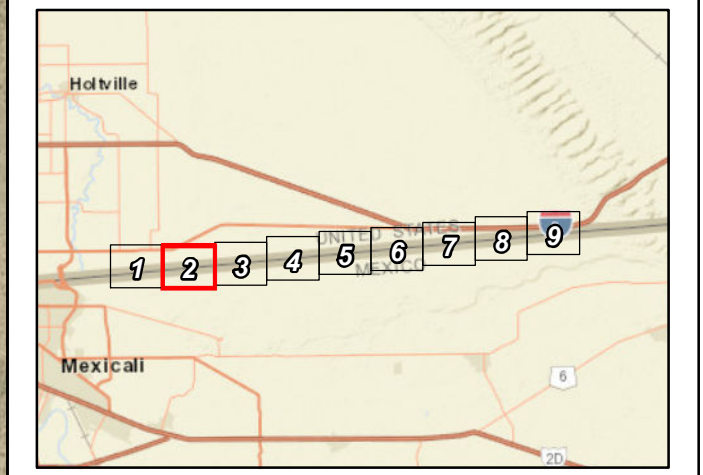




- Map Features**
- Vega 4 Project Area - 440.802
 - Access Road - 69.735 ac.
 - 500' Buffer
- Vegetation Communities and Land Cover Types**
- Channel
 - Creosote Bush Scrub
 - Creosote Bush -White Bursage Scrub
 - Disturbed Creosote-White Bursage Scrub
 - Disturbed
 - Disturbed Arrowweed Scrub
 - Tamarisk Thickets
 - Urban/Developed
 - Urban/Developed - Dirt Road

ECORP: N:\2020\2020-142 Cedar 1 Solar\MAPS\Vegetation_and_LandCover\Vega_4_Access_Road_Vegetation_V2.mxd (TR)-itolini 7/14/2022

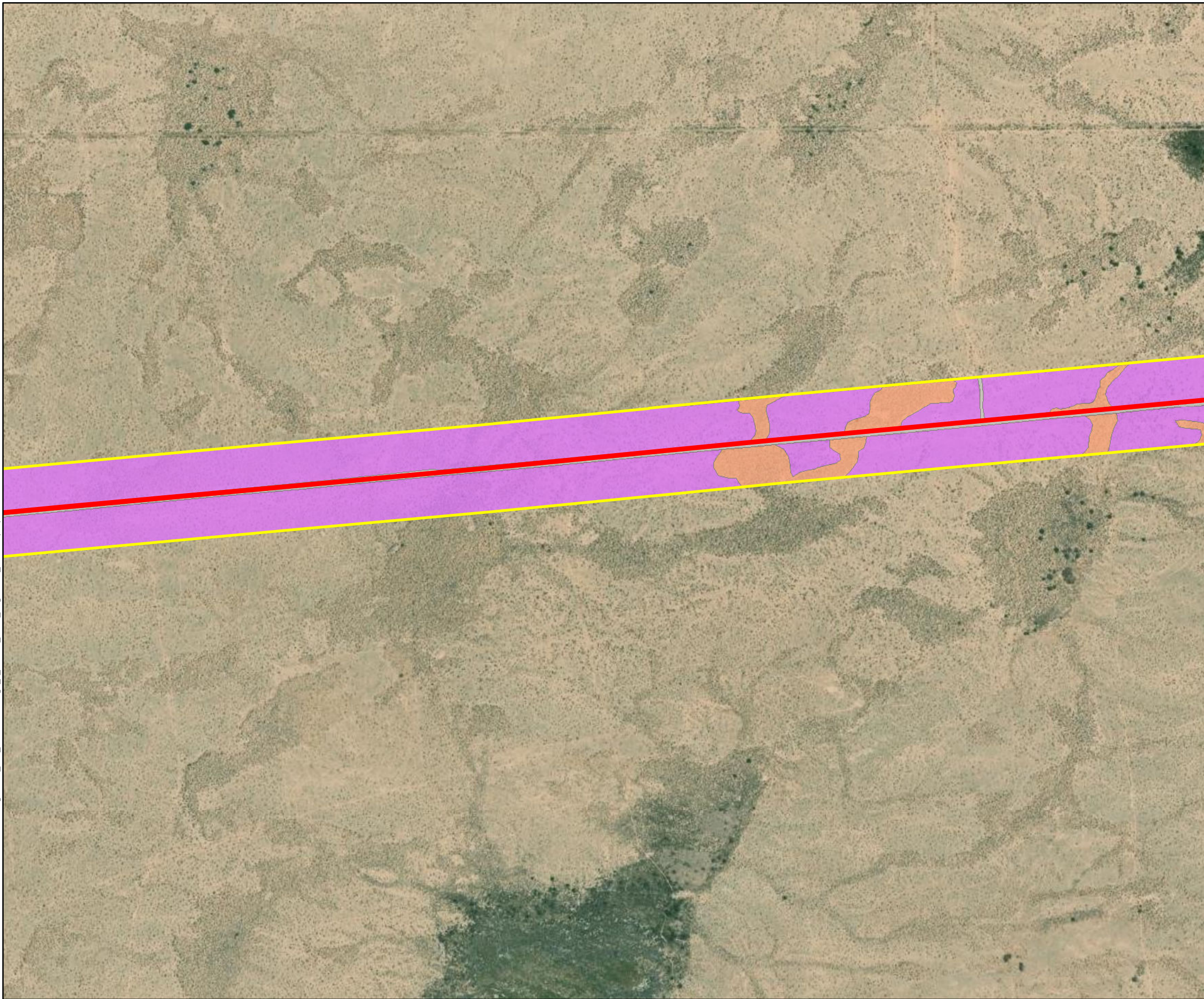
Service Layer Credits: Sources: Esri, HERE, Garmin, USGS, Intermap, INCREMENT P, NRCan, Esri Japan, METI, Esri China (Hong Kong), Esri Korea, Esri (Thailand), NGCC, (c) OpenStreetMap contributors, and the GIS User Community



Map Date: 7/6/2022

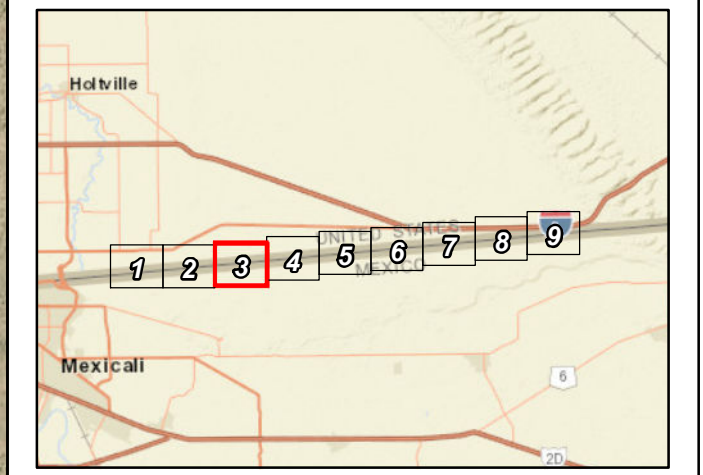


ECORP: N:\2020\2020-142 Cedar 1 Solar\MAPS\Vegetation_and_LandCover\Vega_4_Access_Road_Vegetation_V2.mxd (TP)-rotellini 7/14/2022

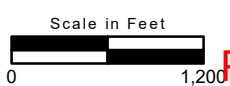


- Map Features**
- Access Road - 69.735 ac.
 - 500' Buffer
- Vegetation Communities and Land Cover Types**
- Creosote Bush Scrub
 - Creosote Bush -White Bursage Scrub
 - Urban/Developed - Dirt Road

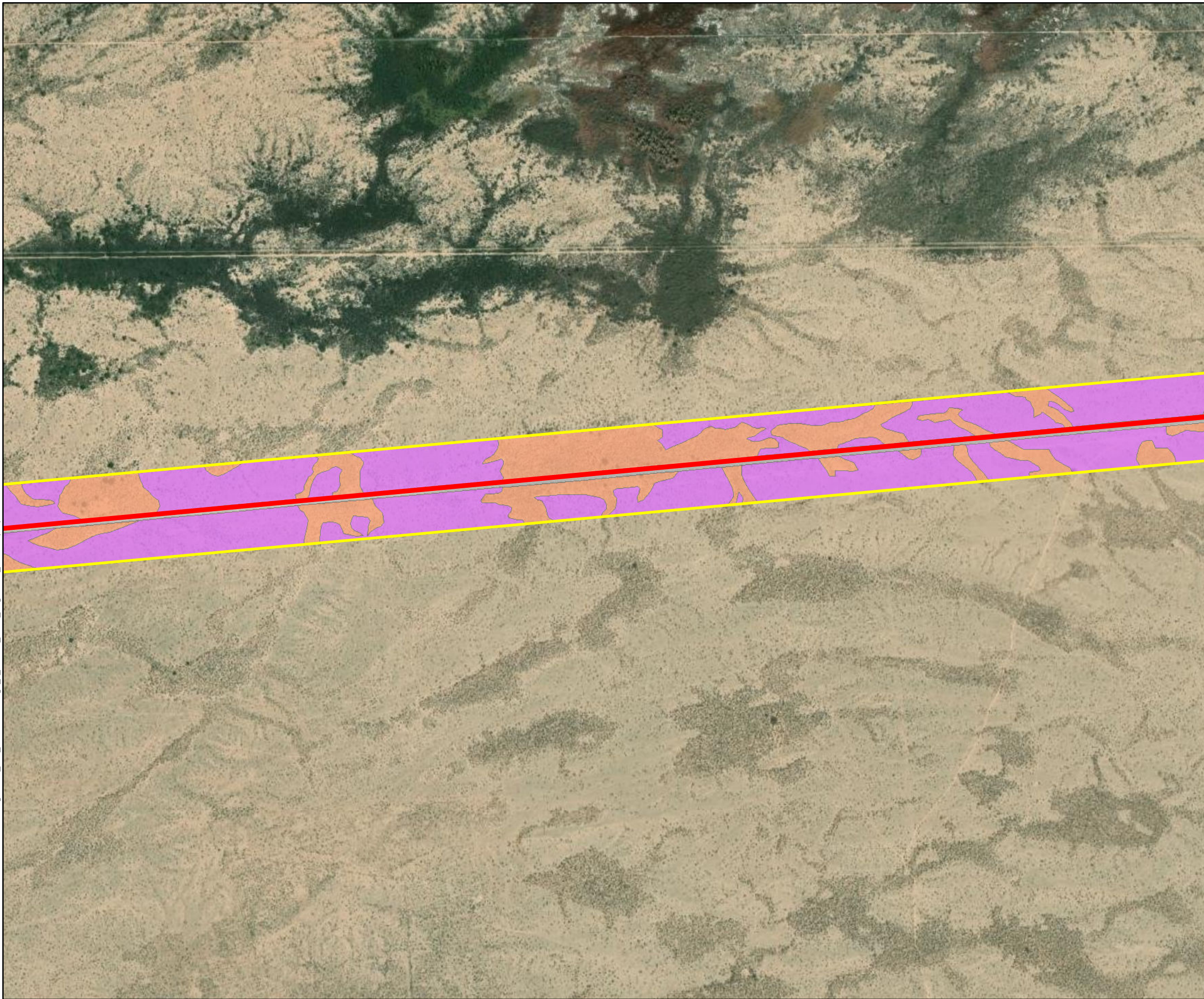
Service Layer Credits: Sources: Esri, HERE, Garmin, USGS, Intermap, INCREMENT P, NRCan, Esri Japan, METI, Esri China (Hong Kong), Esri Korea, Esri (Thailand), NGCC, (c) OpenStreetMap contributors, and the GIS User Community








Map Date: 7/6/2022

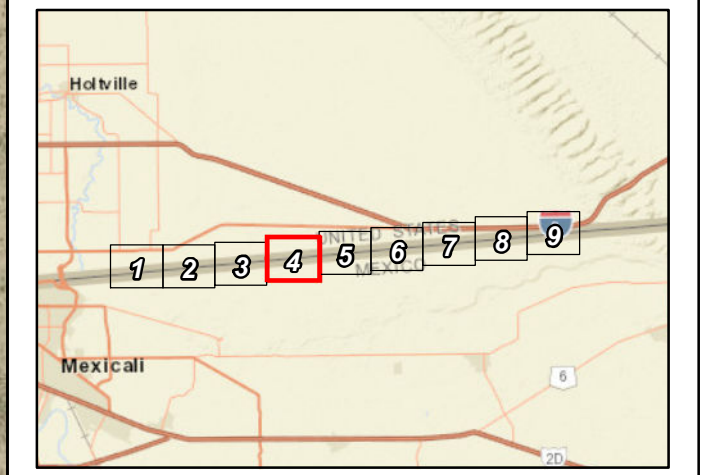


ECORP: N:\2020\2020-142 Cedar 1 Solar\MAPS\Vegetation_and_LandCover\Vega_4_Access_Road_Vegetation_V2.mxd (TJB)-jrotellini 7/14/2022



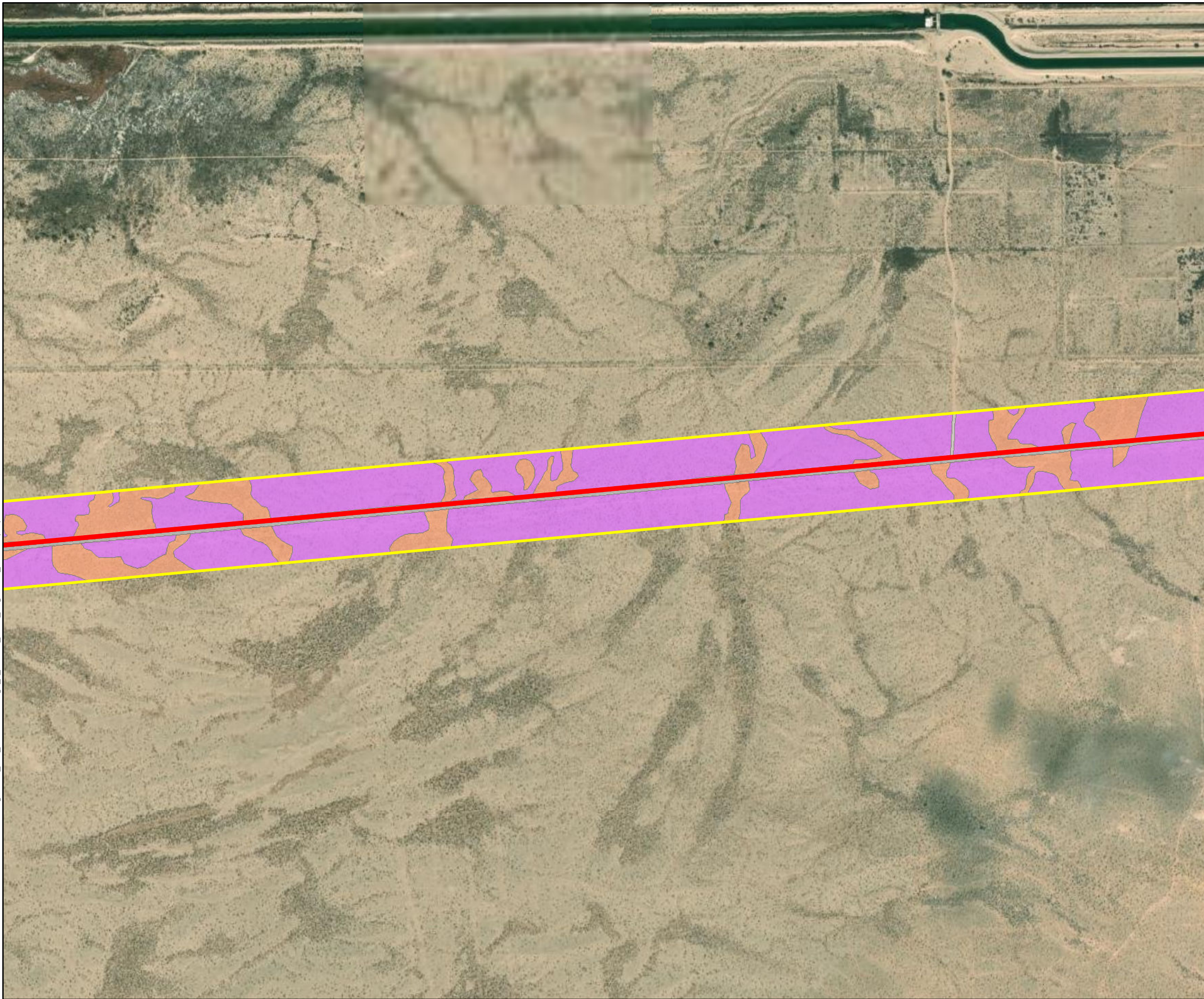
- Map Features**
-  Access Road - 69.735 ac.
 -  500' Buffer
- Vegetation Communities and Land Cover Types**
-  Creosote Bush Scrub
 -  Creosote Bush -White Bursage Scrub
 -  Urban/Developed - Dirt Road






Service Layer Credits: Sources: Esri, HERE, Garmin, USGS, Intermap, INCREMENT P, NRCan, Esri Japan, METI, Esri China (Hong Kong), Esri Korea, Esri (Thailand), NGCC, (c) OpenStreetMap contributors, and the GIS User Community



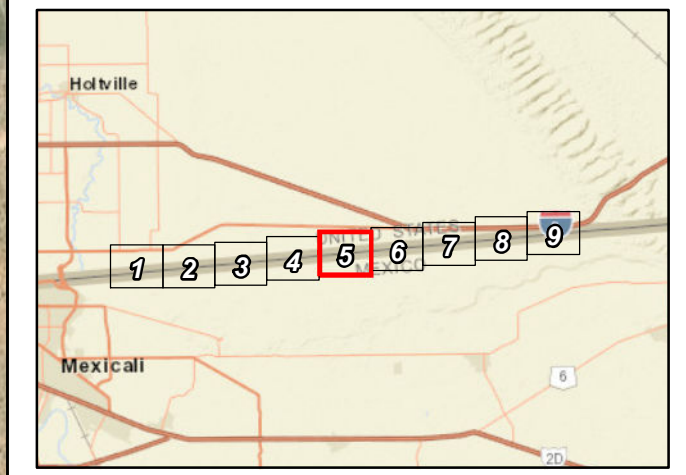
Map Date: 7/6/2022

ECORP: N:\2020\2020-142 Cedar 1 Solar\MAPS\Vegetation_and_LandCover\Vega_4_Access_Road_Vegetation_V2.mxd (TR)-jrotellini 7/14/2022



- Map Features**
-  Access Road - 69.735 ac.
 -  500' Buffer
- Vegetation Communities and Land Cover Types**
-  Creosote Bush Scrub
 -  Creosote Bush -White Bursage Scrub
 -  Urban/Developed - Dirt Road

Service Layer Credits: Sources: Esri, HERE, Garmin, USGS, Intermap, INCREMENT P, NRCan, Esri Japan, METI, Esri China (Hong Kong), Esri Korea, Esri (Thailand), NGCC, (c) OpenStreetMap contributors, and the GIS User Community

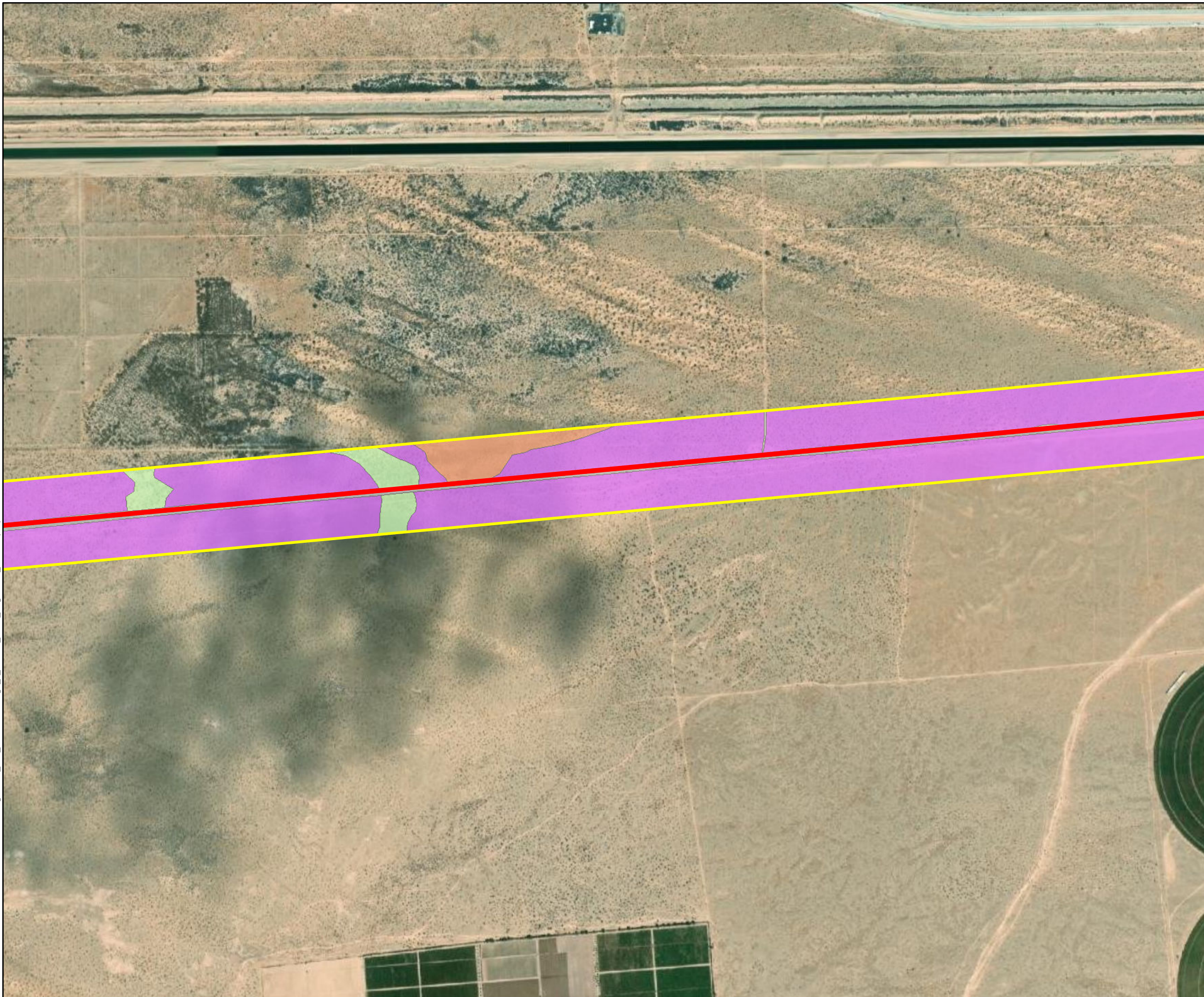








Map Date: 7/6/2022



Figure 4. Vegetation Communities and Land Cover
Sheet 5 of 9
2020-142 Vega SES 4

ECORP: N:\2020\2020-142 Cedar 1 Solar\MAPS\Vegetation_and_LandCover\Vega_4_Access_Road_Vegetation_V2.mxd (TP)-trtelini 7/14/2022



- Map Features**
-  Access Road - 69.735 ac.
 -  500' Buffer
- Vegetation Communities and Land Cover Types**
-  Creosote Bush Scrub
 -  Creosote Bush -White Bursage Scrub
 -  Tamarisk Thickets
 -  Urban/Developed - Dirt Road

Service Layer Credits: Sources: Esri, HERE, Garmin, USGS, Intermap, INCREMENT P, NRCan, Esri Japan, METI, Esri China (Hong Kong), Esri Korea, Esri (Thailand), NGCC, (c) OpenStreetMap contributors, and the GIS User Community

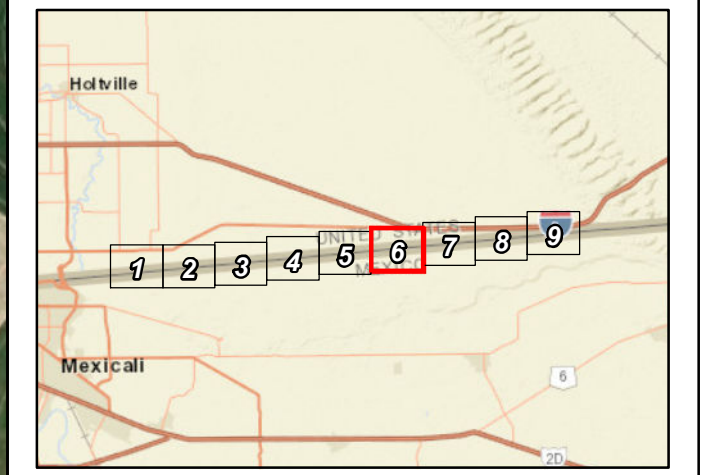
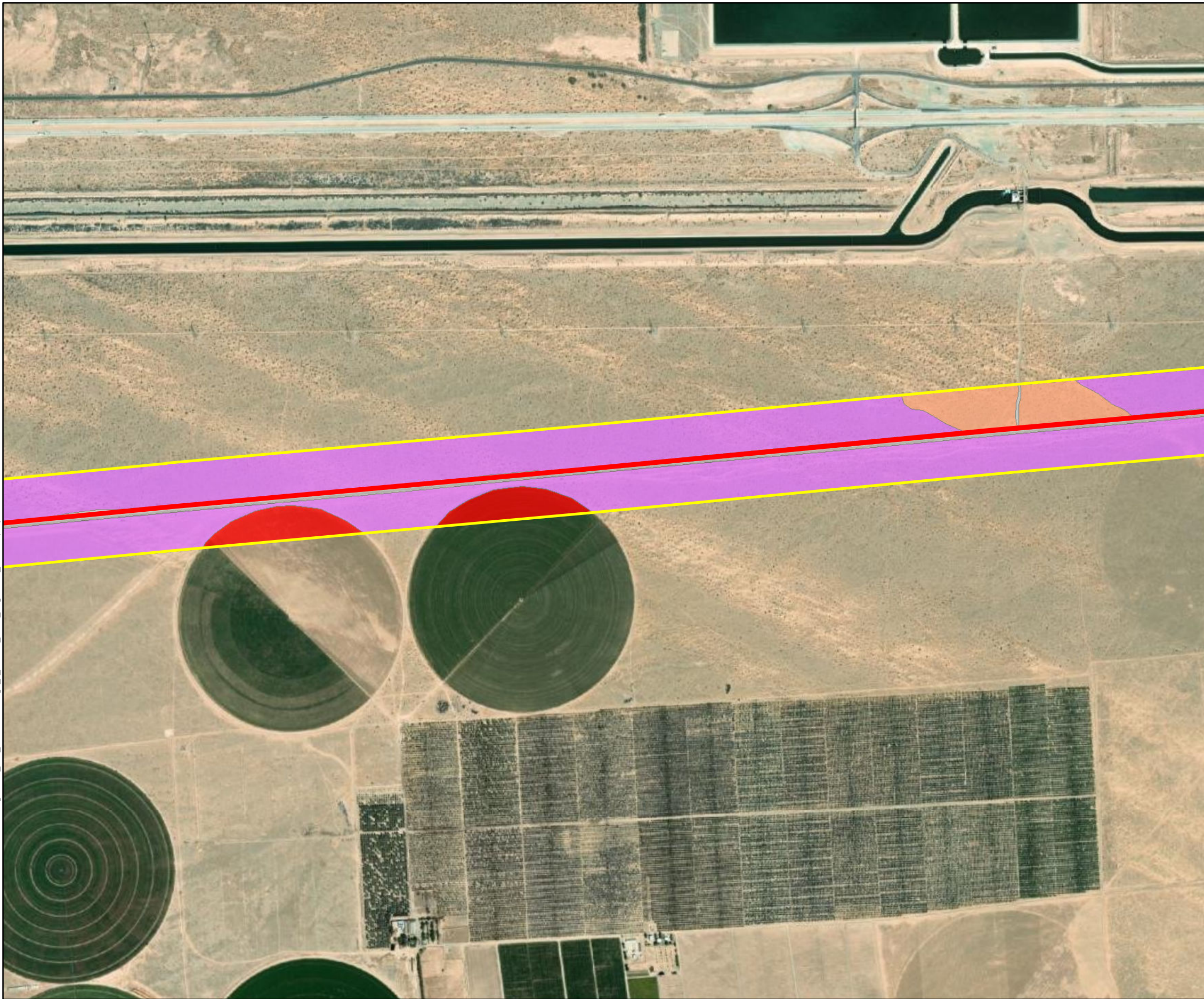


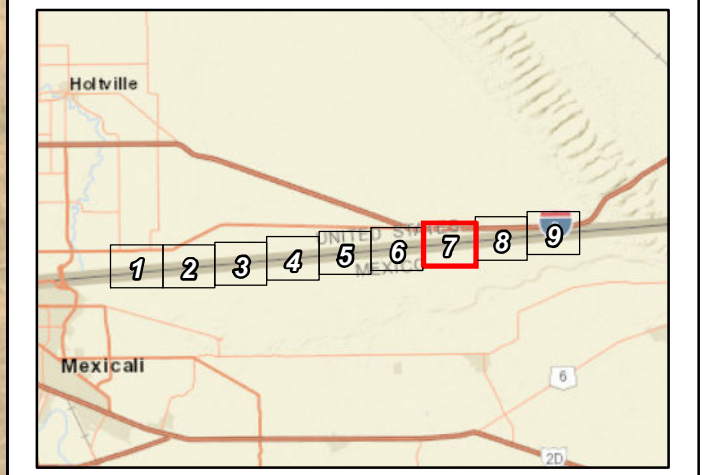
Figure 4. Vegetation Communities and Land Cover
Sheet 6 of 9
 2020-142 Vega SES 4

ECORP: N:\2020\2020-142 Cedar 1 Solar\MAPS\Vegetation and LandCover\Vega_4_Access_Road_Vegetation_V2.mxd (TJB-jrotellini 7/14/2022



- Map Features**
- Access Road - 69.735 ac.
 - 500' Buffer
- Vegetation Communities and Land Cover Types**
- Active Agriculture
 - Creosote Bush Scrub
 - Creosote Bush -White Bursage Scrub
 - Urban/Developed - Dirt Road






Service Layer Credits: Sources: Esri, HERE, Garmin, USGS, Intermap, INCREMENT P, NRCan, Esri Japan, METI, Esri China (Hong Kong), Esri Korea, Esri (Thailand), NGCC, (c) OpenStreetMap contributors, and the GIS User Community



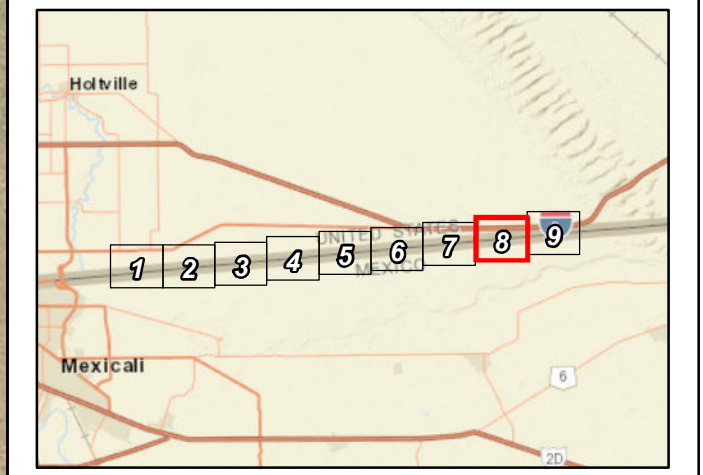
Map Date: 7/6/2022

ECORP: N:\2020\2020-142 Cedar 1 Solar\MAPS\Vegetation_and_LandCover\Vega_4_Access_Road_Vegetation_V2.mxd (TR)-jrotellini 7/14/2022

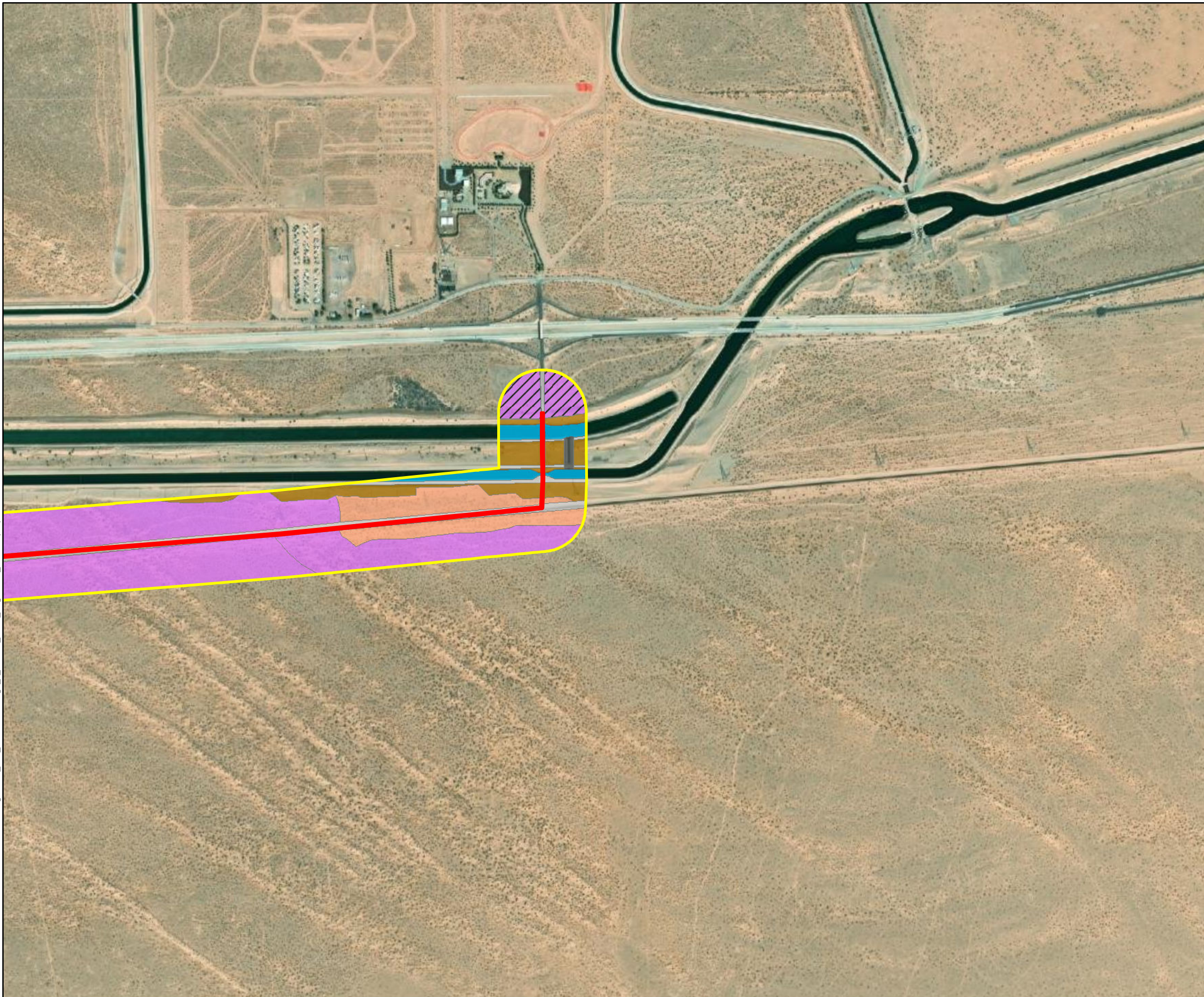


- Map Features**
-  Access Road - 69.735 ac.
 -  500' Buffer
- Vegetation Communities and Land Cover Types
-  Fallow Agriculture
 -  Creosote Bush Scrub
 -  Urban/Developed - Dirt Road

Service Layer Credits: Sources: Esri, HERE, Garmin, USGS, Intermap, INCREMENT P, NRCan, Esri Japan, METI, Esri China (Hong Kong), Esri Korea, Esri (Thailand), NGCC, (c) OpenStreetMap contributors, and the GIS User Community

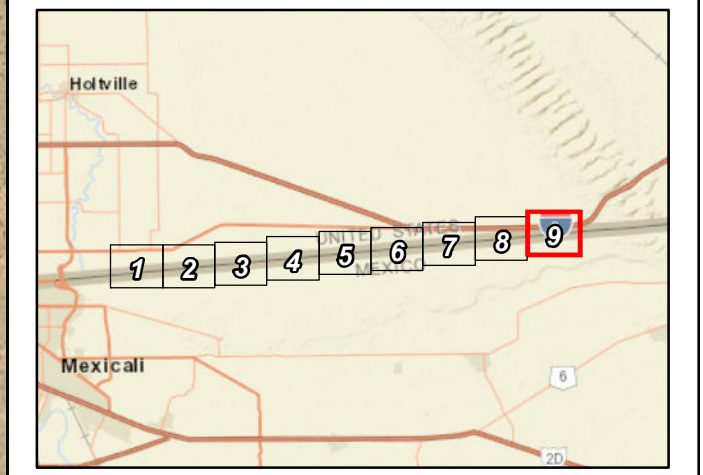


ECORP: N:\2020\2020-142 Cedar 1 Solar\MAPS\Vegetation_and_LandCover\Vega_4_Access_Road_Vegetation_V2.mxd (TR)-trtelini 7/14/2022



- Map Features**
- Access Road - 69.735 ac.
 - 500' Buffer
- Vegetation Communities and Land Cover Types**
- Channel
 - Creosote Bush Scrub
 - Disturbed Creosote Bush Scrub
 - Creosote Bush -White Bursage Scrub
 - Disturbed
 - Urban/Developed
 - Urban/Developed - Dirt Road

Service Layer Credits: Sources: Esri, HERE, Garmin, USGS, Intermap, INCREMENT P, NRCan, Esri Japan, METI, Esri China (Hong Kong), Esri Korea, Esri (Thailand), NGCC, (c) OpenStreetMap contributors, and the GIS User Community



Arrow Weed Thickets (Disturbed; *Pluchea sericea* Shrubland Alliance)

Arrow weed thickets are associated with moderate to dense scrub primarily dominated by arrow weed. Other species that occur as scattered individuals include tamarisk (*Tamarix* spp.), willow baccharis (*Baccharis salicina*), and big saltbush (*Atriplex lentiformis*). This vegetation community appears around springs, seeps, irrigation ditches, canyon bottoms, seasonally flooded washed, stream banks, and within stream beds and ditches. Disturbed arrow weed thickets are arrow weed thickets that have been previously altered. On this Project, this vegetation cover is characterized as sparser. Other plant species observed included alkali goldenbush (*Isocoma acradenia*).

Creosote Bush Scrub (*Larrea tridentata* Shrubland Alliance)

Creosote bush scrub is the most characteristic vegetation of the California desert and is found on alluvial fans, bajadas, upland slopes, and washes. Creosote bush scrub is dominated by a nearly monotypic stand of creosote bush with an open canopy and an herbaceous layer of seasonal annuals and perennials. Other species that occurred on the site included white bursage (*Ambrosia dumosa*), apricot mallow (*Sphaeralcea ambigua*), and fanleaf crinklemat (*Tiquilia plicata*).

Creosote Bush – White Bursage Scrub (Disturbed; *Larrea tridentata* – *Ambrosia dumosa* Shrubland Alliance)

Disturbed creosote bush – white bursage scrub is creosote bush – white bursage scrub that has been previously altered. Creosote and white bursage are co-dominant in the shrub canopy with an absent to intermittent herbaceous layer of seasonal annuals. Within the Project Area, this vegetation cover is characterized as sparser with a high percentage of non-native plant species including common Mediterranean grass (*Schismus barbatus*) and Saharan mustard (*Brassica tournefortii*). Other plant species include dyebush (*Psoralea emoryi*) and crinklemat.

Tamarisk Thickets (*Tamarix* spp. Shrubland Semi-Natural Alliance)

Tamarisk thickets are characterized by a weedy monoculture of tamarisk. This habitat is typically in ditches, washes, rivers, arroyo margins, lake margins, and other watercourses. Within the Project Area, tamarisk and arrow weed were often co-dominant in this vegetation community. Other plant species observed included cattails (*Typha* spp.), screw bean mesquite (*Prosopis pubescens*), and willow baccharis.

Other Land Cover Types*Disturbed*

Disturbed land includes areas where the native vegetation community has been heavily influenced by human actions, such as grading, trash dumping, and OHV use, but lack development. Disturbed land is not a vegetation classification, but rather a land cover type and is not restricted by elevation. On this Project, the areas consisted primarily of bare ground and Mediterranean grass. Other plant species observed on site included dyebush and white bursage.

Urban/Developed

Urban/Developed areas do not constitute a vegetation classification, but rather a land cover type. Areas mapped as developed have been constructed upon or otherwise physically altered to an extent that natural vegetation communities are no longer supported. There may be irrigated, landscaped ornamental species present between the hardscape. Within the Project Area, this land cover was dominant and consisted primarily of compacted dirt roads, structures, and landscape trees including Mexican fan palm (*Washingtonia robusta*) and Mexican palo verde (*Parkinsonia aculeata*). The entirety of the access road is this land cover type.

Vegetation Communities within Survey Area

Four additional vegetation communities were observed within the survey buffer, but not within the Project Area. These land covers are described in detail below. No impacts to these vegetation communities and land covers are expected as a result of Project-related activities.

Creosote Bush – White Bursage Scrub (Larrea tridentata – Ambrosia dumosa Shrubland Alliance)

Creosote bush – white bursage scrub consists of creosote and white bursage that are co-dominant in the shrub canopy with an absent to intermittent herbaceous layer of seasonal annuals. This community was observed adjacent to the access road. Other plant species observed within this community include ephedras (*Ephedra trifurca* and *Ephedra* sp.), alkali goldenbush, and scattered individuals of mesquite.

Creosote Bush Scrub (Disturbed; Larrea tridentata Shrubland Alliance)

Disturbed creosote bush scrub is creosote bush scrub that has been previously altered. This community was observed north of the bridge that spans the All-American Canal and had visible signs of disturbance such as tire tracks and trash. Vegetation within this community was sparser. Other plant species observed include ephedra and crinklemat.

Active Agriculture

Active agriculture includes planted, typically monotypic rows of crops of annual and perennial species with open space between rows. Species composition frequently changes by season and year. Active agriculture often occurs in upland areas with high soil quality, or floodplains and are almost always artificially irrigated. This land cover was observed in the western buffer areas and south of the access road within the country of Mexico.

Fallow Agriculture

Fallow agricultural lands include remnant signs of row crops with open space between rows. Agricultural lands often occur in upland areas with high soil quality, or floodplains, and are almost always artificially irrigated. This land cover was observed periodically to the south of the access road within the country of Mexico. Access to view these areas was obstructed by the U.S./Mexico border wall, but unvegetated row crops were observed from a distance.

4.2.3 Wildlife Observed

Wildlife species observed included zebra-tailed lizard (*Callisaurus draconoides*), great basin whiptail (*Aspidoscelis tigris tigris*), northern harrier (flyover; *Circus hudsonius*), western burrowing owl (*Athene cunicularia hypugaea*), loggerhead shrike (*Lanius ludovicianus*), black-tailed gnatcatcher (*Polioptila melanura*), yellow warbler (*Setophaga petechia*), great egret (*Ardea alba*), American kestrel (*Falco sparverius*), lesser nighthawk (*Chordeiles acutipennis*), ash-throated flycatcher (*Myiarchus cinerascens*), Gambel's quail (*Callipepla gambelii*), Abert's towhee (*Melospiza aberti*), European starling (*Sturnus vulgaris*), killdeer (*Charadrius vociferus*), turkey vulture (*Cathartes aura*), verdin (*Auriparus flaviceps*), great-tailed grackle (*Quiscalus mexicanus*), horned lark (*Eremophila alpestris*), black-necked stilt (*Himantopus mexicanus*), mourning dove (*Zenaida macroura*), greater roadrunner (*Geococcyx californianus*), black phoebe (*Sayornis nigricans*), Say's phoebe (*Sayornis saya*), house finch (*Haemorhous mexicanus*), white-crowned sparrow (*Zonotrichia leucophrys*), Anna's hummingbird (*Calypte anna*), great blue heron (*Ardea herodias*), lesser goldfinch (*Spinus psaltria*), cliff swallow (*Petrochelidon pyrrhonota*), common raven (*Corvus corax*), northern mockingbird (*Mimus polyglottos*), great egret (*Ardea alba*), mallard (*Anas platyrhynchos*), black-tailed jackrabbit (*Lepus californicus*), desert cottontail (*Sylvilagus audubonii*), and signs of coyote (*Canis latrans*), antelope ground squirrel (*Ammospermophilus leucurus*), raccoon (*Procyon lotor*) and bat (Order Chiroptera).

During the 2022 assessment of the access road, a bat roost was observed within the bridge at Gordon Wells Road that crosses the offline storage canal, north of the All-American Canal. This bridge is located at the furthest eastern extent of the access road. Several bats could be heard vocalizing within the bridge and a substantial amount of guano was observed beneath the bridge where surfaces were dry. Species determination and size of the colony would require further analysis via a combination of acoustic monitoring and nighttime emergence surveys. Due to the quantity of bats heard and the time of year of the observation, there is high likelihood that this is a maternity roost. Cliff swallows were also observed nesting along both sides of the aforementioned bridge. Cliff swallows are not a special-status species.

4.3 Special-Status Species Assessment

The literature review resulted in 14 special-status plant and 21 special-status wildlife species that have historically been recorded in the vicinity of the Project or that are highly associated with habitat that occurs within the Project Area. Special-status plants were evaluated for their potential to occur within the Project Area where impacts could occur. Special-status wildlife were evaluated for their potential to occur within the Survey Area, a broader area that includes the Project Area and buffer, where direct or indirect impacts could occur.

4.3.1 Plants

Numerous special-status plant species have been recorded within five miles of the Project Area, according to the CNDDDB (CDFW 2022a), IPaC (USFWS 2022b), and CNPSEI (CNPS 2022). Of all available records, a total of 14 species were identified as those with the potential for occurrence within the vicinity of the Project Area. Descriptions of the CNPS designations are found in Table 4 and a list of the special-status plant species identified in the literature review is presented following Table 4.

Table 4. CNPS Status Designations	
List Designation	Meaning
1A	Plants Presumed Extirpated in California and Either Rare or Extinct Elsewhere
1B	Plants Rare, Threatened, or Endangered in California and Elsewhere
2A	Plants Presumed Extirpated in California, But Common Elsewhere
2B	Plants Rare, Threatened, or Endangered in California, But More Common Elsewhere
3	Plants about which we need more information; a review list
4	Plants of limited distribution; a watch list
List 1B, 2, and 4 extension meanings:	
.1	Seriously threatened in California (over 80 percent of occurrences threatened / high degree and immediacy of threat)
.2	Moderately threatened in California (20-80 percent occurrences threatened / moderate degree and immediacy of threat)
.3	Not very threatened in California (less than 20 percent of occurrences threatened / low degree and immediacy of threat or no current threats known)

Note: According to CNPS (Skinner and Pavlik 1994), plants on Lists 1B and 2 meet definitions for listing as threatened or endangered under Section 1901, Chapter 10 of the California Fish and Game Code (California Department of Fish and Game [CDFG] 1984). This interpretation is inconsistent with other definitions.

Plant Species with a Moderate Potential to Occur

Due to the presence of suitable habitat and several known occurrences within five miles of the Project Area, the following species was determined to have a moderate potential to occur:

- Abrams' spurge (*Euphorbia abramsiana*) is a CNPS Rare Plant Rank (CRPR) 2B.2 plant species. This species is known to occur at elevations between 50 and 100 meters (164 and 328 feet) and blooms between September – November. Abrams' spurge is known to occur in creosote scrub habitat within sandy flats including playas, fields, disturbed areas, and washes. One historic CNDDDB record was located approximately three miles west of the Project Area near the Alamo River. Potential habitat occurs within the Project Area for this species in the creosote bush scrub and the disturbed creosote bush – white bursage scrub habitats.
- Wiggins' croton (*Croton wigginsii*) is a CRPR 2B.2 plant species. This species is known to occur at elevations between 50 and 100 meters (164 and 328 feet) and blooms between March and May. Wiggins' croton is known to occur in sandy Sonoran desert scrub habitat. Two historic CNDDDB records were recorded with the closest being from 1993 located approximately 0.92 miles east of the Project Area. Potential habitat occurs within Project Area for this species in the sandy, creosote bush scrub and the disturbed creosote bush – white bursage scrub habitats.

- Sand food (*Pholisma sonora*) is a CRPR 1B.2 plant species. This parasitic species attaches to the roots of host *Eriogonum*, *Tiquilia*, *Ambrosia*, and *Pluchea* species. Sand food is known to occur at elevations between sea level and 200 meters (sea level and 656 feet) and blooms between April and June. It is known to occur in sandy Sonoran desert scrub habitat. One historic CNDDDB record from 1954 was recorded approximately 0.5 mile north of the Project Area. Potential habitat occurs within the Project Area for this species in the sandy, creosote bush scrub and the disturbed creosote bush – white bursage scrub habitats.

Plant Species with Low Potential to Occur

The following species were found to have a low potential to occur within the Project Area because of limited habitat for the species on the site and a known occurrence has been reported in the database, but not within five miles of the Project Area, or suitable habitat strongly associated with the species occurs within the Project Area, but no records were found in the database search:

- Watson's amaranth (*Amaranthus watsonii*), CRPR 4.3
- Peirson's milk-vetch (*Astragalus magdalena* var. *peirsonii*), federally listed threatened, state-listed endangered, CRPR 1B.2
- gravel milk-vetch (*Astragalus sabulonum*), CRPR 2B.2
- Algodones Dunes sunflower (*Helianthus niveus* ssp. *tephrodes*), state-listed endangered, CRPR 1B.2
- California satintail (*Imperata brevifolia*), CRPR 2B.1
- ribbed cryptantha (*Johnstonella costata*), CRPR 4.3
- winged cryptantha (*Johnstonella holoptera*), CRPR 4.3
- hairy stickleaf (*Mentzelia hirsutissima*), CRPR 4.3
- Darlington's blazing star (*Mentzelia puberula*), CRPR 2B.2
- slender cottonheads (*Nemacaulis denudata* var. *gracilis*), CRPR 2B.2
- giant Spanish-needle (*Palafoxia arida* var. *gigantea*), CRPR 1B.3

4.3.2 Wildlife

The literature search documented 21 special-status wildlife species in the vicinity of the Project Area, two of which are federally and/or state-listed. Of the 21 special-status wildlife species identified in the literature review, five were present within the Project Area, two were found to have a high potential to occur, seven were found to have a moderate potential to occur and three were found to have a low potential to occur; the remaining three species are presumed absent from the Project Area. Descriptions of the federal and state wildlife designations are found in Table 5, and a brief natural history and

discussion of the special-status wildlife species found onsite that have a high or moderate potential to occur within the Project Area are provided below.

Table 5. Wildlife Status Designations	
List Designation	Meaning
Federal Designation	Jurisdiction under United States Fish and Wildlife Service (USFWS)
END	Federally listed as Endangered
THR	Federally listed as Threatened
CAN	Federal Candidate Species
FSC	Federal Species of Concern
FPD	Federal Proposed for Delisting
BBC	Bird of Conservation Concern
State Designation	Jurisdiction under California Fish and Wildlife Service (CDFW)
END	State listed as Endangered
THR	State listed as Threatened
SSC	California Species of Special Concern
FP	Fully Protected Species
WL	Watch List

Special-Status Wildlife Species Present

The following species were observed on the site during the reconnaissance survey:

- Northern harrier is a CDFW SSC. This species is typically found in open habitats with dense ground cover including grasslands, agricultural fields, and marshes. Northern harriers nest on the ground, preferring wetland habitat for cover. One adult was observed scanning the landscape of the Project Area during the habitat assessment in 2020.
- Burrowing owl is a USFWS BCC, a CDFW SSC, and Imperial County species of conservation focus. It is typically found in dry open areas with few trees and short grasses; it is also found in vacant lots near human habitation. It uses uninhabited mammal burrows for roosts and nests, often in close proximity to California ground squirrel colonies. It primarily feeds on large insects and small mammals but will also eat birds and amphibians. Three burrowing owls were observed flushing from/to their burrows; two within the southern portion of the Project Area and one from a rubble pile of the northern portion of the Project Area in 2020 (Figure 5). One within the southern portion of the Project Area was occupying a burrow along the berm of the access road.

- Black-tailed gnatcatcher is a CDFW WL species. This species remains in pairs all year, defending permanent territories. Black-tailed gnatcatchers prefer dry washes or desert brush with varied growth of mesquite, acacias, and paloverdes, but are also known to inhabit tamarisk scrub. A pair of black-tailed gnatcatchers was observed foraging and calling within the tamarisk thicket to the west within the buffer of the Project Area in 2020. This species was observed again within the same area in 2022 (Figure 5).
- Yellow warbler is a USFWS BBC and CDFW SCC. This species prefers scrub and woodlands, particularly along waterways and wetlands. Typically, yellow warblers nest in willows, alders, and cottonwoods, but have been observed nesting in tamarisk thickets. Several adults were observed foraging in the tamarisk thicket within the buffer to the northwest of the Project Area in 2020 (Figure 5).
- Loggerhead shrike is a USFWS BCC and CDFW SSC. This species prefers open country with scattered shrubs and trees. They frequent agricultural fields, abandoned orchards, desert scrublands, and riparian areas. One individual was observed perching in the tamarisk thickets in the western section of the Project Area in 2020. An individual was also observed perched within the creosote bush scrub habitat to the north of the access road in 2022.

Special-Status Wildlife Species with a High Potential to Occur

Two species were found to have high potential to occur within the Project Area due to the presence of suitable habitat for the species on the site and because a known occurrence has been recorded within five miles of the site:

- Flat-tailed horned lizard (*Phrynosoma mcallii*) is a CDFW SSC and Imperial County Species of conservation focus. This species is most commonly found on sandy flats and valleys within desert scrub habitat with little or no windblown sand. They can also be found on salt flats and gravelly soils. The creosote bush scrub and salt flat habitats provide suitable habitat for the flat-tailed horned lizard. Four recent CNDDDB records occur within five miles of the Project Area. The closest recorded occurrence is less than one mile north of the site from 2014.
- Yuma hispid cotton rat (*Sigmodon hispidus eremicus*) is a CDFW SSC. This species is generally associated with mesic habitats near drainage ditches, streams, and sloughs but also occurs in open fields or on the borders of open fields where there is dense grass habitat or agricultural fields. There is potential for this species to occur near the All-American Canal and nearby dense arrow weed thicket and tamarisk thicket habitats. Two recent CNDDDB records occur less than one mile north of the access road for the site. This species was found in arrow weed scrub and freshwater marsh adjacent to the All-American Canal in 2007.

ECORP: N:\2020\2020-142 Cedar 1 Solar\MAPS\Biological Resources\Vega_4_Access_Road_SSS_Observation_V2.mxd (TR)-rotellini 7/6/2022



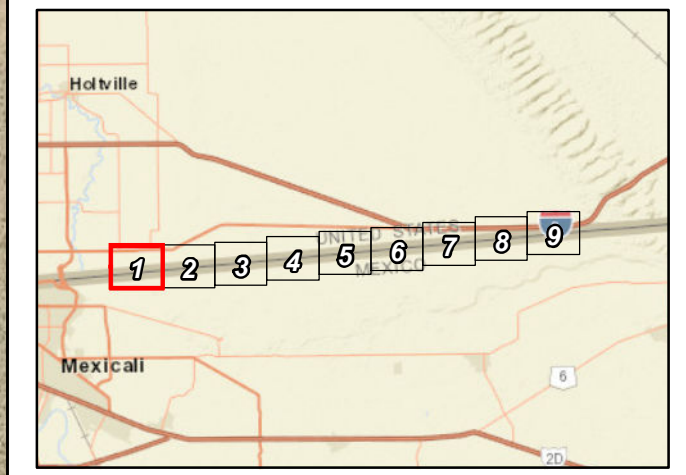
Map Features

- Vega 4 Project Area - 440.802
- 500' Buffer

Special-status Species Observations

- Black-tailed gnatcatcher (*Poliptila melanura*)
- Burrowing owl (*Athene cunicularia*)
- Loggerhead shrike (*Lanius ludovicianus*)
- Yellow warbler (*Setophaga petechia*)

Service Layer Credits: Sources: Esri, HERE, Garmin, USGS, Intermap, INCREMENT P, NRCan, Esri Japan, METI, Esri China (Hong Kong), Esri Korea, Esri (Thailand), NGCC, (c) OpenStreetMap contributors, and the GIS User Community



Map Date: 7/6/2022

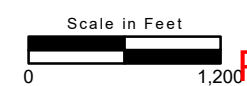
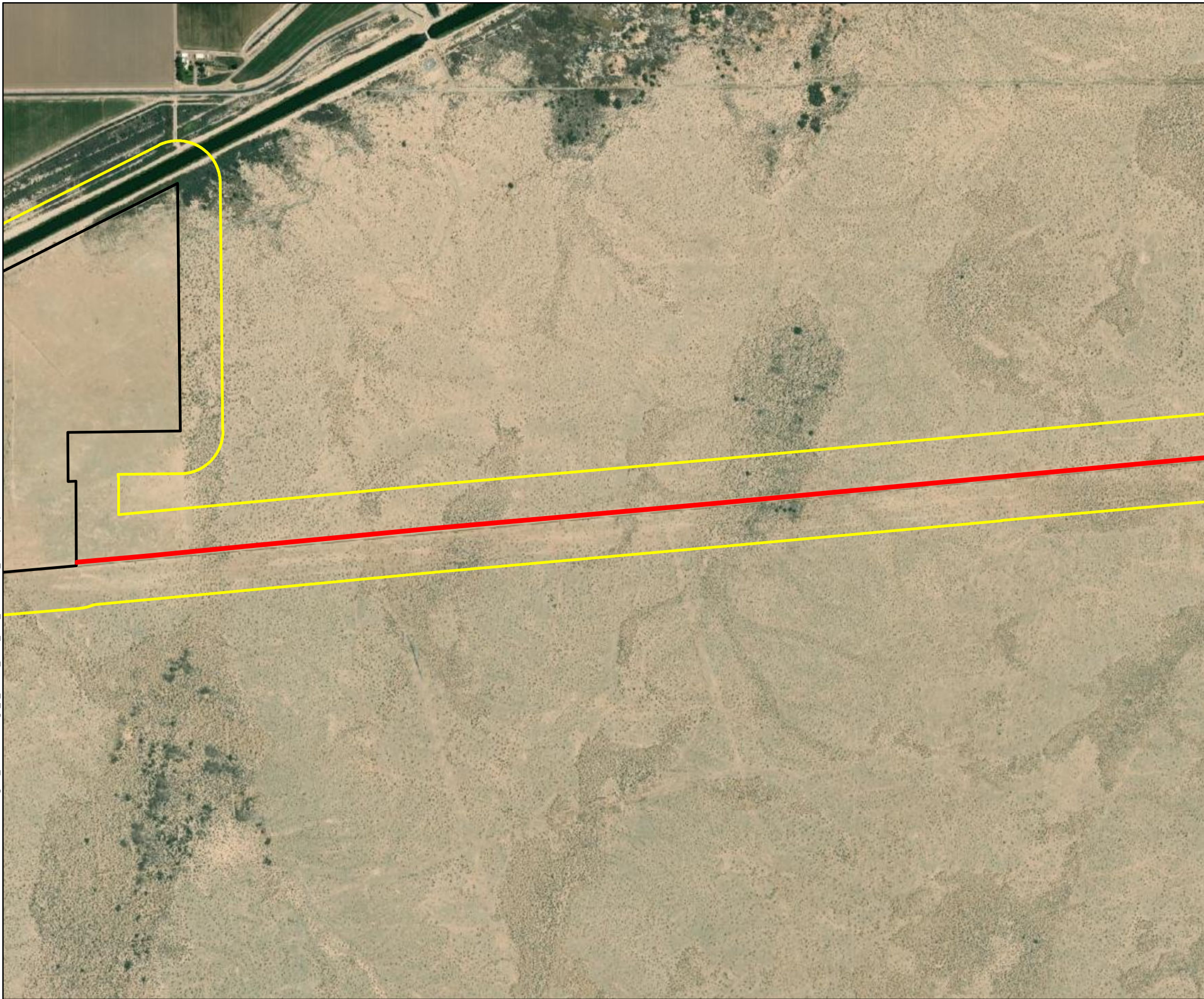





Figure 5. Special-status Species Observations
Sheet 1 of 9
2020-142 Vega SES 4

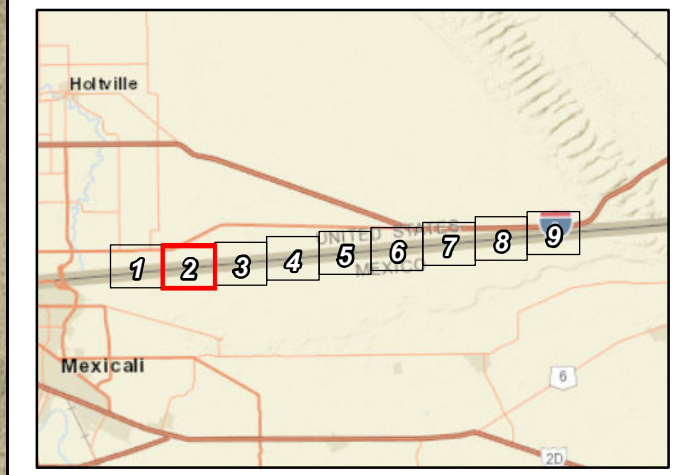
ECORP: N:\2020\2020-142 Cedar 1 Solar\MAPS\Biological_Resources\Vega_4_Access_Road_SSS_Observation_V2.mxd (TR)-rotellini 7/6/2022



Map Features

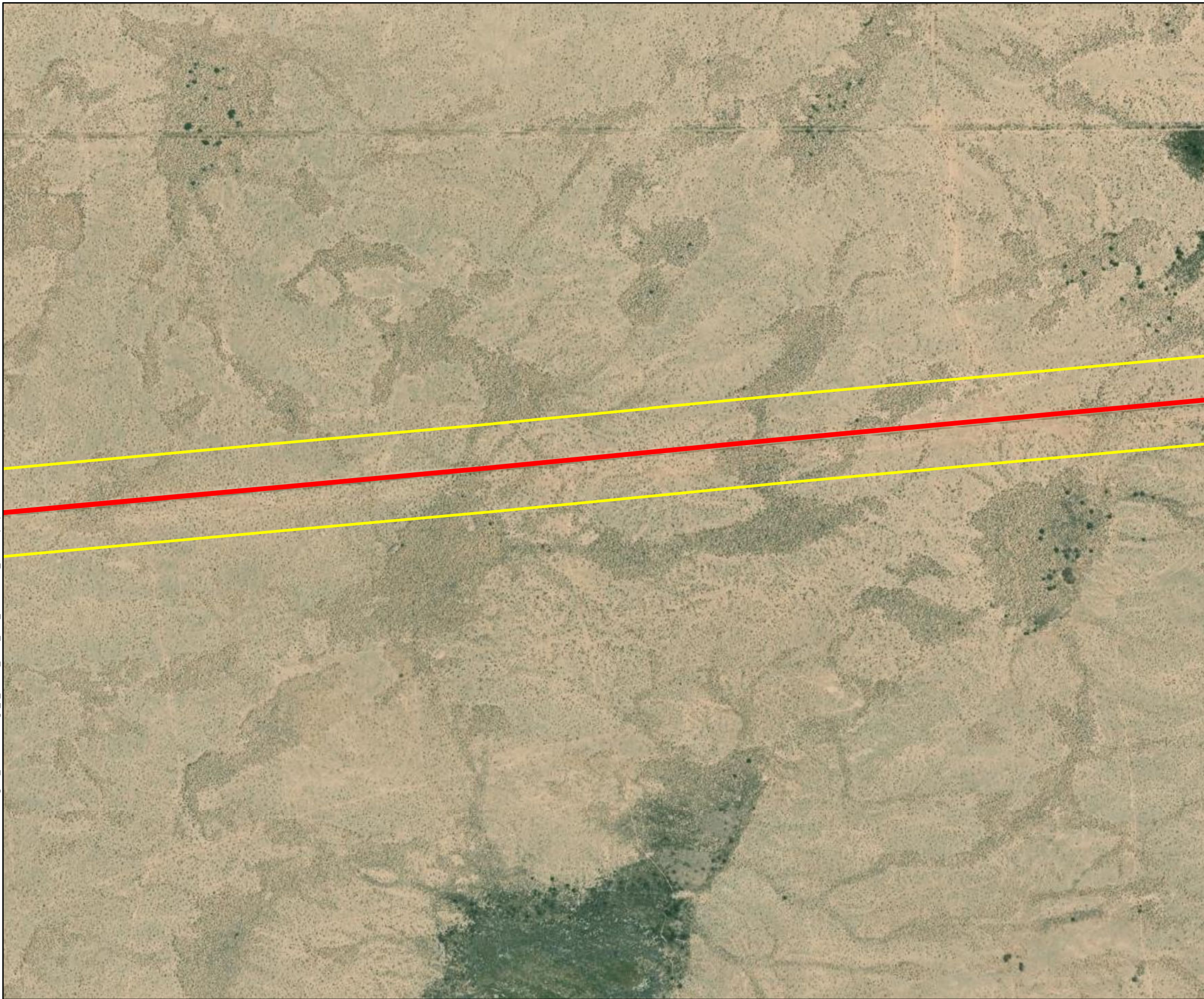
-  Vega 4 Project Area - 440.802
-  Access Road - 69.735 ac.
-  500' Buffer

Service Layer Credits: Sources: Esri, HERE, Garmin, USGS, Intermap, INCREMENT P, NRCan, Esri Japan, METI, Esri China (Hong Kong), Esri Korea, Esri (Thailand), NGCC, (c) OpenStreetMap contributors, and the GIS User Community





Map Date: 7/6/2022

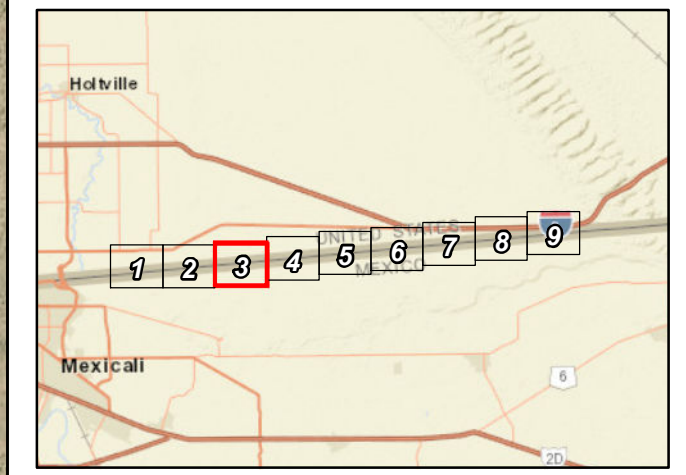
ECORP: N:\2020\2020-142 Cedar 1 Solar\MAPS\Biological_Resources\Vega_4_Access_Road_SSS_Observation_V2.mxd (TR)-rotellini 7/6/2022



Map Features

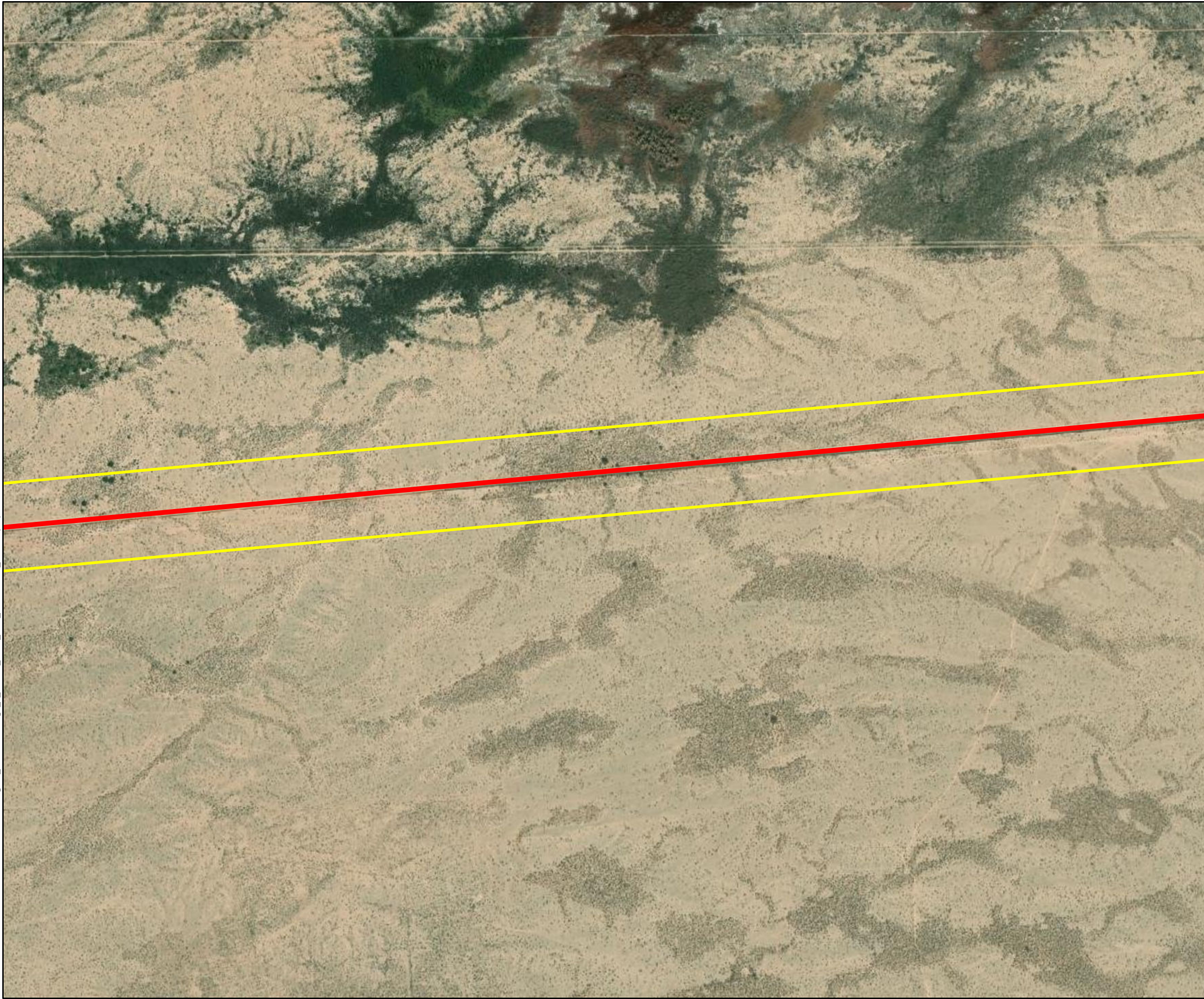
-  Access Road - 69.735 ac.
-  500' Buffer

Service Layer Credits: Sources: Esri, HERE, Garmin, USGS, Intermap, INCREMENT P, NRCan, Esri Japan, METI, Esri China (Hong Kong), Esri Korea, Esri (Thailand), NGCC, (c) OpenStreetMap contributors, and the GIS User Community





Map Date: 7/6/2022

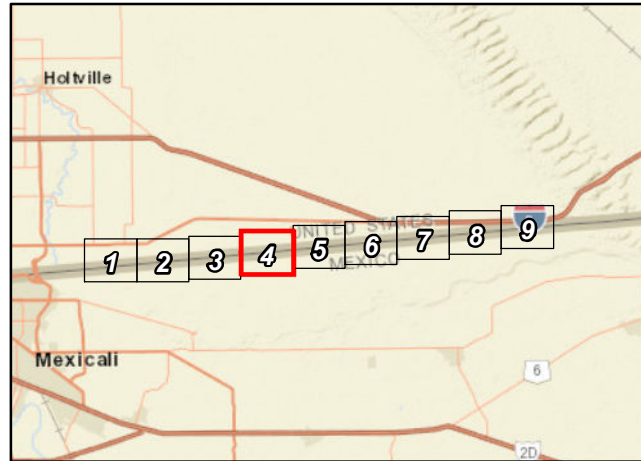
ECORP: N:\2020\2020-142 Cedar 1 Solar\MAPS\Biological_Resources\Vega_4_Access_Road_SSS_Observation_V2.mxd (TR)-rpt\lml 7/6/2022



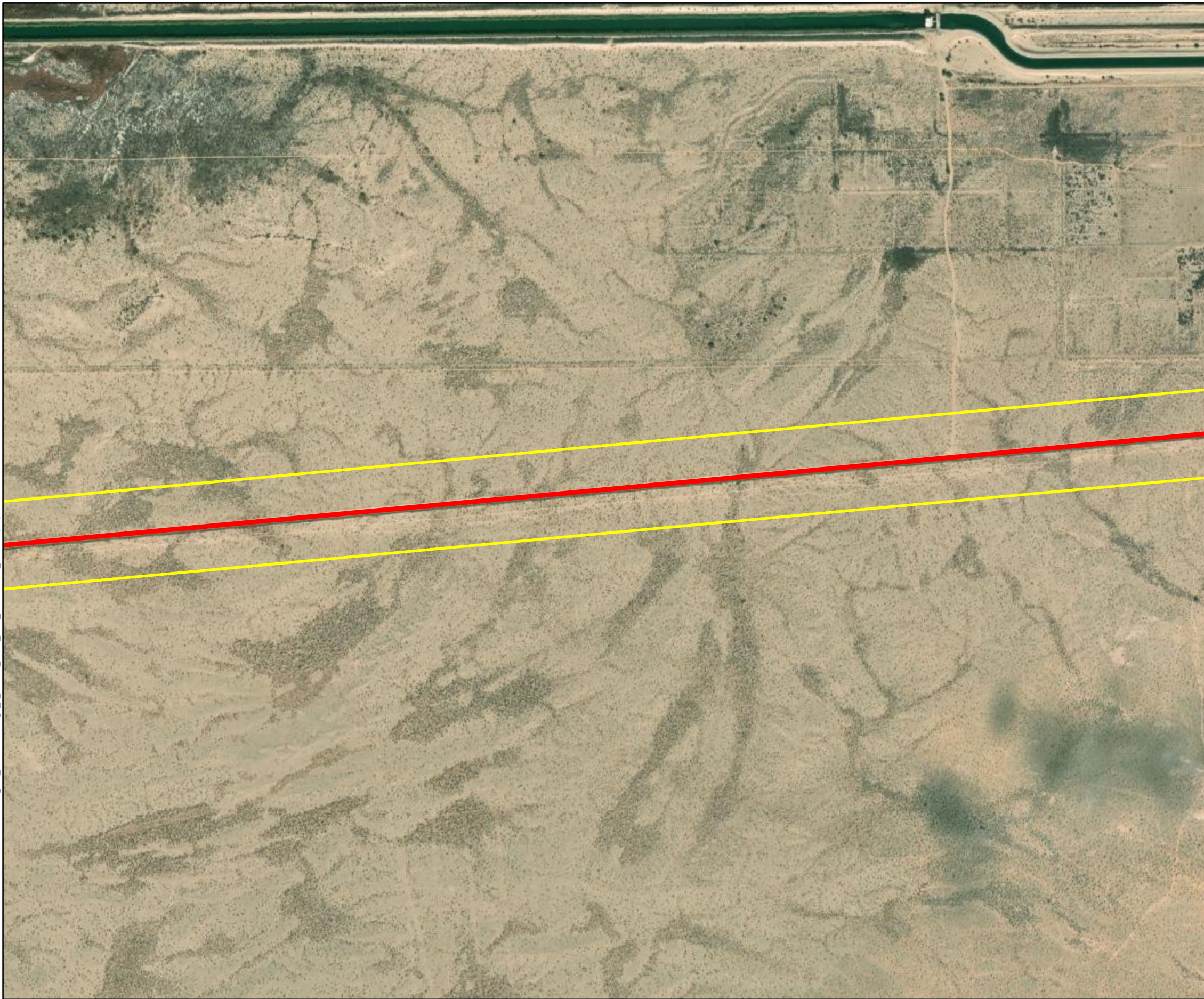
Map Features

-  Access Road - 69.735 ac.
-  500' Buffer



Service Layer Credits: Sources: Esri, HERE, Garmin, USGS, Intermap, INCREMENT P, NRCan, Esri Japan, METI, Esri China (Hong Kong), Esri Korea, Esri (Thailand), NGCC, (c) OpenStreetMap contributors, and the GIS User Community



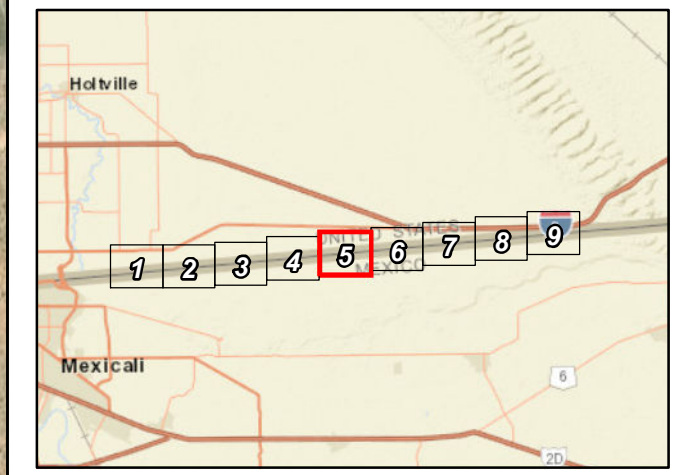
ECORP: N:\2020\2020-142 Cedar 1 Solar\MAPS\Biological_Resources\Vega_4_Access_Road_SSS_Observation_V2.mxd (TR)-rpt\lml 7/6/2022



Map Features

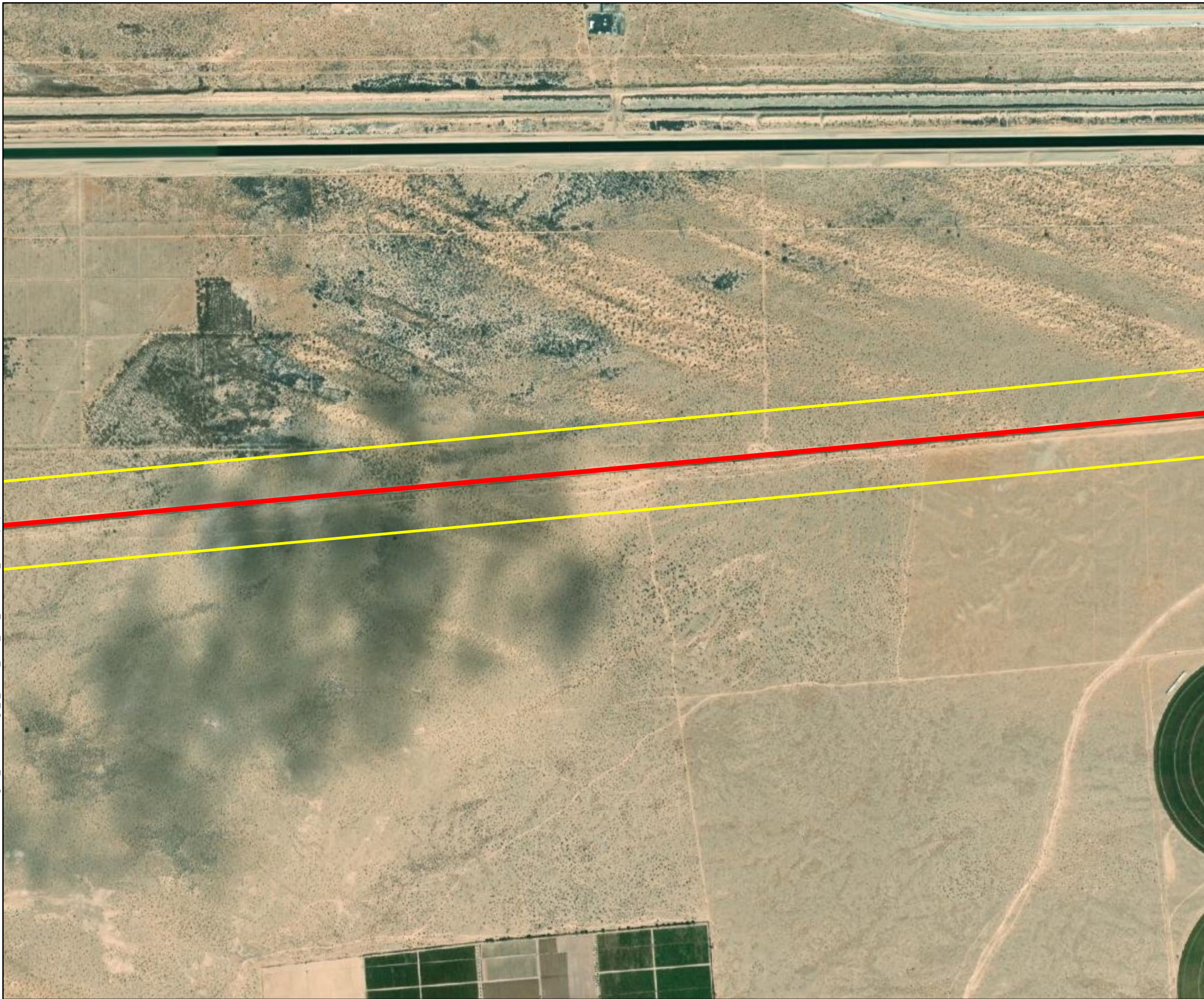
-  Access Road - 69.735 ac.
-  500' Buffer

Service Layer Credits: Sources: Esri, HERE, Garmin, USGS, Intermap, INCREMENT P, NRCan, Esri Japan, METI, Esri China (Hong Kong), Esri Korea, Esri (Thailand), NGCC, (c) OpenStreetMap contributors, and the GIS User Community





Map Date: 7/6/2022

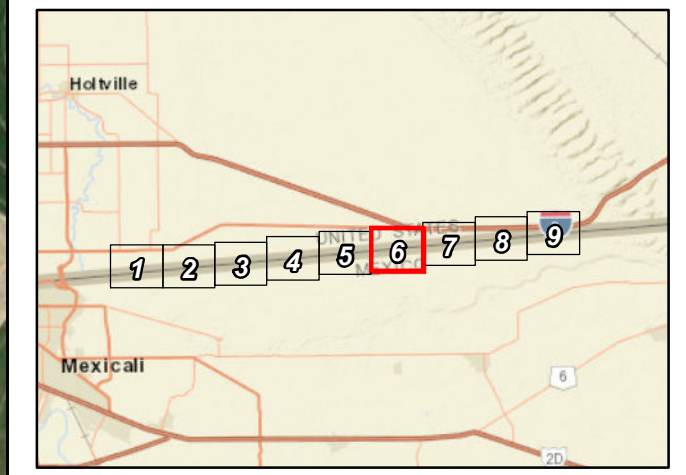
ECORP: N:\2020\2020-142_Cedar_1_Solar\MAPS\Biological_Resources\Vega_4_Access_Road_SSS_Observation_V2.mxd (TR)-rpt\lml\ 7/6/2022



Map Features

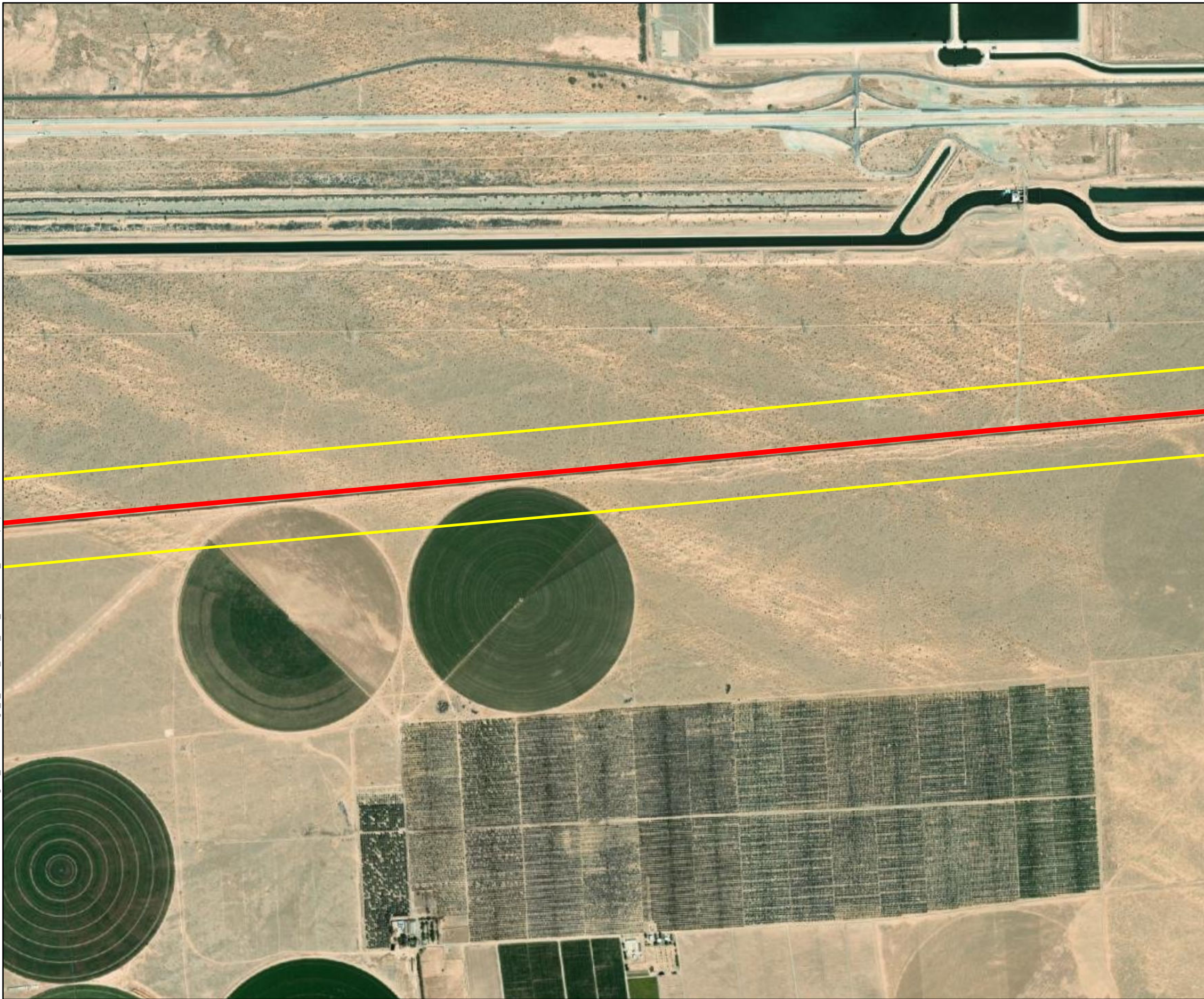
-  Access Road - 69.735 ac.
-  500' Buffer

Service Layer Credits: Sources: Esri, HERE, Garmin, USGS, Intermap, INCREMENT P, NRCan, Esri Japan, METI, Esri China (Hong Kong), Esri Korea, Esri (Thailand), NGCC, (c) OpenStreetMap contributors, and the GIS User Community





Map Date: 7/6/2022

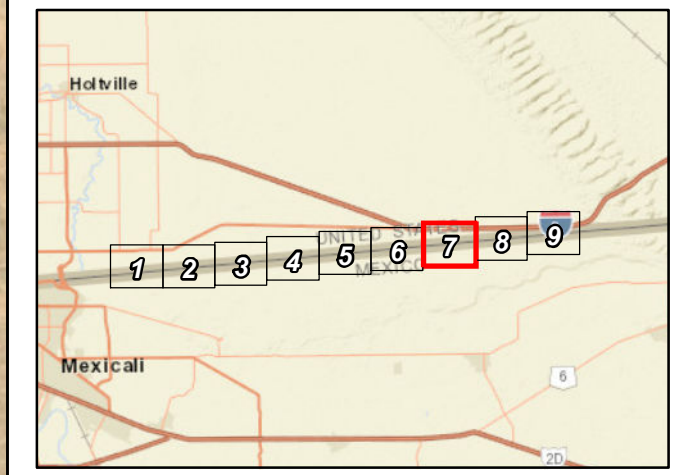
ECORP: N:\2020\2020-142_Cedar_1_Solar\MAPS\Biological_Resources\Vega_4_Access_Road_SSS_Observation_V2.mxd (TR)-rotellini 7/6/2022



Map Features

-  Access Road - 69.735 ac.
-  500' Buffer

Service Layer Credits: Sources: Esri, HERE, Garmin, USGS, Intermap, INCREMENT P, NRCan, Esri Japan, METI, Esri China (Hong Kong), Esri Korea, Esri (Thailand), NGCC, (c) OpenStreetMap contributors, and the GIS User Community





Map Date: 7/6/2022



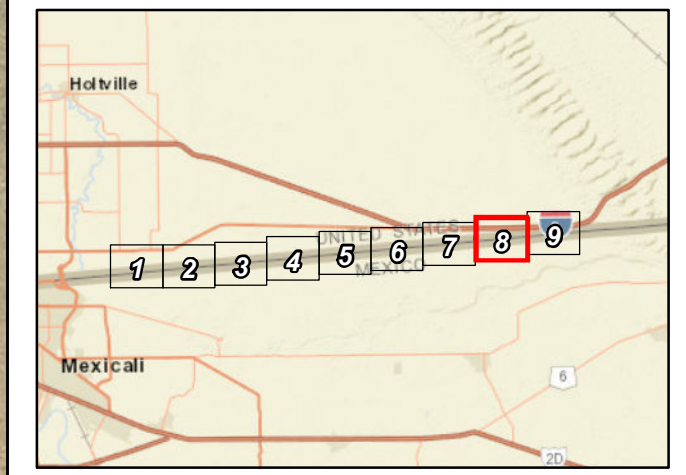
ECORP: N:\2020\2020-142_Cedar_1_Solar\MAPS\Biological_Resources\Vega_4_Access_Road_SSS_Observation_V2.mxd (TR)-rotellini 7/6/2022



Map Features

-  Access Road - 69.735 ac.
-  500' Buffer

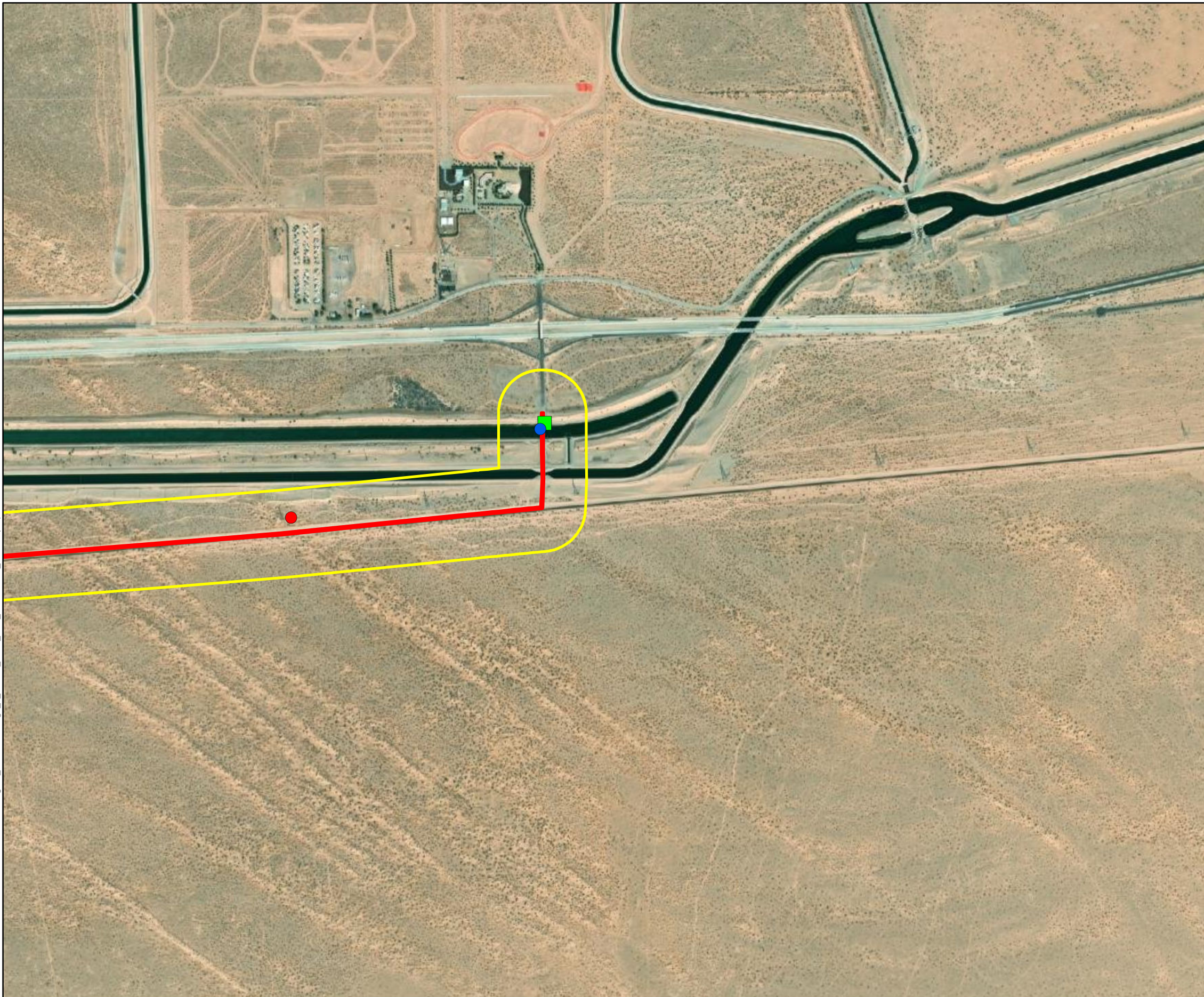
Service Layer Credits: Sources: Esri, HERE, Garmin, USGS, Intermap, INCREMENT P, NRCan, Esri Japan, METI, Esri China (Hong Kong), Esri Korea, Esri (Thailand), NGCC, (c) OpenStreetMap contributors, and the GIS User Community



Map Date: 7/6/2022



ECORP: N:\2020\2020-142 Cedar 1 Solar\MAPS\Biological_Resources\Vega_4_Access_Road_SSS_Observation_V2.mxd (TRY) - 7/6/2022



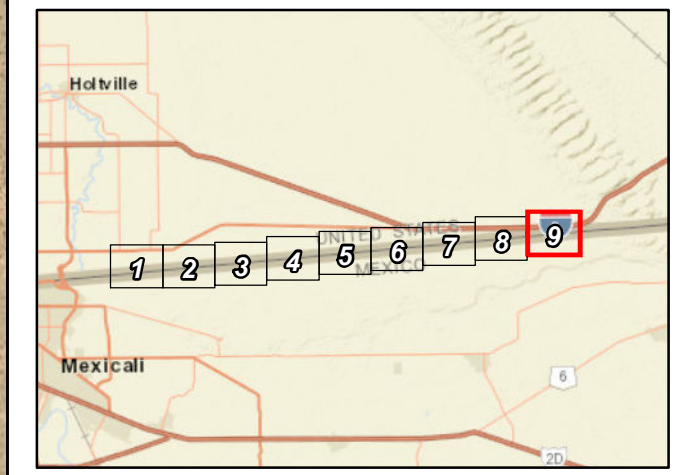
Map Features

- Access Road - 69.735 ac.
- 500' Buffer

Special-status Species Observations

- Cliff swallow (*Petrochelidon pyrrhonota*) Nesting Site
- Loggerhead shrike (*Lanius ludovicianus*)
- Bat Roosting Site

Service Layer Credits: Sources: Esri, HERE, Garmin, USGS, Intermap, INCREMENT P, NRCan, Esri Japan, METI, Esri China (Hong Kong), Esri Korea, Esri (Thailand), NGCC, (c) OpenStreetMap contributors, and the GIS User Community



Map Date: 7/6/2022

Special-Status Wildlife Species with a Moderate Potential to Occur

Seven species were found to have moderate potential to occur within the Project Area because habitat (including soils and elevation factors) for the species occurs on the site and a known occurrence exists within the database search, but not within five miles of the site; or a known occurrence exists within five miles of the site and marginal or limited amounts of habitat occurs within the Project Area:

- Yuma Ridgway's rail (*Rallus obsoletus yumanensis*) is a federally listed endangered and state-listed threatened species. The Yuma Ridgway's rail prefers freshwater marshes composed of cattails and bulrushes. There is suitable habitat for this species within the wetlands nestled within the tamarisk and arrow weed scrub.
- California horned lark (*Eremophila alpestris ssp. actia*) is a CDFW WL species. It occurs in bare, open areas dominated by low vegetation or widely scattered shrubs, including prairies, deserts, and plowed fields. It nests in a hollow on the ground. The disturbed creosote scrub habitat onsite and in the buffer zones provides potential habitat. No CNDDDB records occur within five miles of the Project Area.
- Yellow-breasted chat (*Icteria virens*) is a CDFW SSC. This species is commonly found in shrublands along rivers. There is potential for the yellow-breasted chat to occur within the arrow weed and tamarisk scrub in the eastern portion of the Project Area.
- Pallid bat (*Antrozous pallidus*) is a CDFW SSC. This species is commonly found in desert habitat and is known to roost in bridges. Potential roosting habitat for this species is present within the within the Gordon Wells Road bridge that crosses over the offline storage canal, north of the All-American Canal.
- Townsend's big-eared bat (*Corynorhinus townsendii*) is a CDFW SSC. The Project Area is within the known range of this species and this species is known to roost in bridges. Potential roosting habitat for this species is present within the within the Gordon Road Wells bridge that crosses over the offline storage canal, north of the All-American Canal.
- Western yellow bat (*Lasiurus xanthinus*) is a CDFW SSC. This species is commonly found in desert habitat and is known to roost in the skirts of untrimmed palm trees. Potential roosting habitat for this species is present within the palm trees of the northeastern portion of the Project Area.
- Arizona myotis (*Myotis occultus*) is a CDFW SSC. The Project Area is within the known range of this species and this species is known to roost in bridges. Potential roosting habitat for this species is present within the Gordon Wells Road bridge that crosses over the offline storage canal, north of the All-American Canal.

Wildlife Species with Low Potential to Occur

Three species were found to have a low potential to occur within the Project Area because limited habitat for the species occurs on the site and a known occurrence has been reported in the database, but not

within five miles of the site, or suitable habitat strongly associated with the species occurs on the site, but no records were found in the database search:

- southwestern willow flycatcher (*Empidonax traillii* ssp. *extimus*), federally listed endangered and state-listed endangered ,
- Sonoran desert toad (*Incilius alvarius*), CDFW SSC, and
- red-diamond rattlesnake (*Crotalus ruber*), CDFW SSC.

Wildlife Species Presumed Absent

The following three species are presumed absent from the Project Area due to the lack of suitable habitat on the site:

- Gila woodpecker (*Melanerpes uropygialis*), USFWS BCC and CDFW END,
- western mastiff bat (*Eumops perotis* ssp. *californicus*), CDFW SSC, and
- big free-tailed bat (*Nyctinomops macrotis*), CDFW SSC.

4.4 Jurisdictional Aquatic Resources Assessment

An aquatic resources delineation was conducted by ECORP biologists during a separate survey effort, the results of which are presented under separate cover (ECORP 2022).

4.5 Wildlife Movement Corridors, Linkages, and Significant Ecological Areas

The concept of habitat corridors addresses the linkage between large blocks of habitat that allow the safe movement of mammals and other wildlife species from one habitat area to another. The definition of a corridor is varied, but corridors may include such areas as greenbelts, refuge systems, underpasses, and biogeographic land bridges, for example. In general, a corridor is described as a linear habitat, embedded in a dissimilar matrix, which connects two or more large blocks of habitat. Wildlife movement corridors are critical for the survivorship of ecological systems for several reasons. Corridors can connect water, food, and cover sources, spatially linking these three resources with wildlife in different areas. In addition, wildlife movement between habitat areas provides for the potential of genetic exchange between wildlife species populations, thereby maintaining genetic variability and adaptability to maximize the success of wildlife responses to changing environmental conditions. This is especially critical for small populations subject to loss of variability from genetic drift and effects of inbreeding. Naturally, the nature of corridor use and wildlife movement patterns varies greatly among species.

The Project Area was assessed for its ability to function as a wildlife corridor. The Project Area has an extensive riparian corridor in the western corner of the site that provides cover for migrating and nesting birds. It also provides foraging habitat for raptors and small and large mammals, including rodents and canids. The desert washes located within the western corner of the Project boundaries are likely utilized by wildlife moving through the area; therefore, these features and associated riparian habitat would be considered necessary linkages between conserved natural habitat areas or critical for wildlife movement because of the nearby direct connectivity to wetlands to the south of the Project Area. The northern and

southern boundaries are restricted by the All-American Canal to the north and the U.S./Mexico border wall borders the southern buffer of the Project Area. Although the border wall inhibits large mammal movement, avian species and small mammals may fly over or cross through the wall.

The disturbed creosote bush scrub portion of the Project is sparse with low plant diversity, and therefore offers little shelter and foraging habitat. The Project Area is open with barriers to the north and south, leaving the terrain accessibility constrained for ground-truthing wildlife. The Project borders the western edge of expansive agricultural fields and is surrounded to the north, west, and south by agriculture. Thus, the creosote scrub habitat only currently provides wildlife movement opportunities to the east because it consists of open and relatively unimpeded land. In conclusion, the creosote bush scrub habitat portion of the Project would not be considered a wildlife movement corridor that would need to be preserved to allow wildlife to move between important natural habitat areas due to the lack of conserved natural lands in the vicinity and the Project's proximity to farming lands. The creosote bush scrub habitat within the Project boundaries is exposed and does not contain any major features that would be considered critical movement corridors for wildlife. Therefore, the creosote bush habitat acts as more of a buffer between agricultural lands and wildlands to the east, but not as a corridor for wildlife.

5.0 IMPACT ASSESSMENT

Implementation of the Project has potential to impact creosote bush scrub, disturbed arrow weed thickets, disturbed creosote-white bursage scrub, and tamarisk thickets. These communities may provide suitable nesting and foraging habitat for passerines, including Yuma's Ridgway rail, burrowing owl, yellow warbler, loggerhead shrike, black-tailed gnatcatcher, raptor foraging habitat, and rare plant habitat. Conceptual design of the Project has not been finalized; therefore, impacts and minimization measures cannot be confirmed at this time. The following recommendations would be required to determine if the Project would result in significant impacts to vegetation communities, special-status plant and wildlife species, jurisdictional waters, and wildlife movement corridors.

5.1.1 Special-Status Species

Special-Status Plants

The literature review identified 14 special-status plant species that have the potential to occur within the Project Area. However, 11 of these plant species have a low potential to occur due to the limited suitable habitat within the Project Area. These species include Watson's's amaranth, Peirson's milk-vetch, gravel milk-vetch, Algodones Dunes sunflower, California satintail, ribbed cryptantha, winged cryptantha, hairy stickleaf, Darlington's blazing star, slender cottonheads, and giant Spanish-needle.

There is moderate potential for three rare plant species, Abram's spurge (CRPR 2B.2), Wiggins' croton (CRPR 2B.2), and sand food (CRPR 1B.2), to be present within the Project Area. Suitable habitat for this species is present within the creosote bush scrub and disturbed creosote bush – white bursage scrub habitats. Impacts that may occur to the species includes loss of individuals, habitat, and seedbank. Depending on the size of the population, this impact may be significant. Implementation of BIO-1 and BIO-2 is recommended to reduce impacts to a less than significant level.

Special-Status Wildlife

The literature review identified 21 special-status wildlife species that have the potential to occur within the Project Area. However, six of these species have a low or no potential to occur due to the lack of suitable and/or limited habitat within the Project Area. Wildlife species that are presumed absent from the Project Area include Gila woodpecker, western mastiff bat, and big free-tailed bat. Wildlife species with a low potential to occur include Sonoran Desert toad, red-diamond rattlesnake, and southwestern willow flycatcher.

Five special-status wildlife species were observed on site during the habitat assessment. Black-tailed gnatcatcher, northern harrier, yellow warbler, and loggerhead shrike were observed in the tamarisk and arrow weed thickets in the western portion of the Project Area and buffer. Burrowing owl and their burrows were observed within the disturbed creosote-white bursage scrub in the western portion of the Project Area, within a berm adjacent to the access road, and in a concrete pile in the northeastern corner of the site. Direct impacts to these species that could occur include injury, mortality, nest failures, and loss of young. Indirect impacts include loss of nesting and foraging habitat, increase in anthropogenic effects (i.e., noise levels, introduction of invasive/nonnative species, increase in human activity, increase in dust). Impacts to these species could be considered significant; therefore, implementation of BIO-2, BIO-3, BIO-4, BIO-5, and BIO-7 is recommended.

Foraging habitat for a number of raptor species and breeding habitat for numerous passerine species that are protected by the MBTA occurs throughout the Project Area. The site provides nesting habitat for ground-nesting species as well as species that nest in riparian scrub habitat. Due to the lack of large trees within the Survey Area, there is no suitable nesting habitat for raptor species. However, northern harriers are ground nesters; therefore, the tamarisk thicket and disturbed arrow weed thicket habitats provide potential nesting habitat for this species. Direct impacts to nesting avian species include injury, mortality, loss of young, and nest failure. Indirect impacts include loss of foraging and nesting habitat for passerine and raptors species, increase in noise and human activities, and potential introduction of invasive/nonnative species. Implementation of BIO-4, BIO-5, and BIO-7 are recommended to mitigate for potential impacts.

The palm trees located within the Project Area may provide roosting habitats for bat species, particularly western yellow bat, a SSC species. These trees could function as maternity roost sites for this species. During the 2022 assessment of the access road, a bat roost was observed within the bridge at Gordon Wells Road that crosses the offline storage canal, north of the All-American Canal. Bat species in California are protected by Section 4150 (protection of non-game mammals from take) of the California Fish and Game Code. Section 4150 of the California Fish and Game Code prohibits the take of any naturally occurring mammals in California that are nongame mammals, which includes all species of the Order Chiroptera (bats). Based on the quantity of bats within the bridge and the timing of the observation of the colony, there is high likelihood that this is a maternity roost. The Gordon Wells Road bridge will be used for access to the solar field portion of the Project Area and no direct impacts are expected to occur to the bridge. There may be indirect impacts to the roost through noise and vibration, due to a temporary increase in traffic above the bridge. However, because the bridge currently functions as an active roadway, the colony would be expected to be accustomed to noise and vibrations associated with traffic and

indirect impacts would not be expected to be significant. The main Project Area is located approximately 22 miles west of the bridge and work is expected to occur within a 12-month period. An increase in truck traffic over the bridge to facilitate construction of the Project is not expected to have a significant impact on the bat colony and will be temporary in nature. Once completed, the bridge directly northeast of the Project (near where the East Highline Canal intersects the All-American Canal) will be used for site access instead of the Gordon Wells Road bridge. The bridge directly northeast of the Project is frequently used by U.S. Border Patrol and IID and was not assessed for bat occupation due to it being outside of the Project Area.

The Gordon Wells Road bridge and 22-mile access road will be used during the construction phase of the Project due to the use of heavier equipment. Bat acoustic surveys and monitoring should be implemented to determine if sensitive bat species occur within the Gordon Road Wells bridge or palm trees (if planned for removal). All bat species with potential for occurrence for the Project are SSC species and Project-related impacts to bat species and bat maternity roosts are potentially significant. Impacts to bat species are expected to be temporary in nature and individual bats are expected to be able to vacate the trees that are removed during construction without being subject to harm if a two-step palm tree removal process is conducted. The two-step removal process for palm trees involves the following:

- The uppermost live fronds (the top of the tree) should be removed entirely on the first day along with the upper 25 percent of the frond skirt. This method would allow for sufficient disturbance of the tree that would encourage any roosting bats within the frond skirt to abandon the tree during evening emergence without directly impacting roosting bats within the skirt. The remainder of the tree should be removed the following day.
- If bats emerge at any time during the tree trimming, trimming activities should cease at that individual tree for the remainder of the day to allow for any additional bats roosting in the tree to emerge during evening hours when it is safe and appropriate for them to do so. Trimming of the tree may resume the following morning.
- Tree trimming activities in the fall should be conducted on days when weather conditions are such that roosting bats are unlikely to be in torpor (predicted overnight lows on evenings before and after the tree trimming activities are above 45 degrees Fahrenheit) to the extent practicable.

Implementation of BIO-9 would reduce impacts to bat species and maternity roosts to a less than significant level.

5.1.2 Sensitive Natural Communities

The ±511-acre Project Area and accompanying access road is comprised of disturbed creosote-white bursage scrub, creosote bush scrub, disturbed arrow weed thickets, tamarisk thickets, and urban/developed land, which would be directly impacted by the Project. Active agriculture, fallow agriculture, disturbed creosote bush scrub, and creosote bush – white bursage scrub occur within the Project buffer area. In-kind mitigation, up to 3:1 ratio, may be required by CDFW to offset impacts to disturbed arrow weed thickets and tamarisk thickets in order to reduce impacts to a less than significant level.

Implementation of BIO-7 is recommended to reduce potential impacts.

5.1.3 State- and/or Federally Protected Wetlands and Waters

The results of the Aquatic Resources Delineation and discussion of potential impacts on State or federally protected wetlands or Waters of the U.S. are discussed in the Aquatic Resources Delineation Report (ECORP 2022), prepared under separate cover. Implementation of BIO-6 is recommended to mitigate for potential significant impacts.

5.1.4 Wildlife Corridors and Nursery Sites

The Project Area is located adjacent to areas containing existing disturbances (i.e., roads, border wall, and active agricultural land). The majority of the site does not contain suitable vegetation and/or cover to support wildlife movement and is nestled on the edge of agricultural and development; therefore, wildlife movement opportunities connecting the Project Area to large, undeveloped natural areas is extremely limited. However, the riparian habitat could act as a potential corridor and nursery site for migrating wildlife species. Therefore, implementation of BIO-2, BIO-4, BIO-5, BIO-6, and BIO-7 are recommended to mitigate for potential significant impacts.

5.1.5 Habitat and Conservation Plans and Natural Community Conservation

There is no Imperial County Plan or local plan at the time of this report; therefore, consultation with USFWS and CDFW would be required should listed plant and/or wildlife species be found to occur.

6.0 RECOMMENDATIONS AND MITIGATION MEASURES

The following recommendations have been developed in accordance with the CEQA impacts analysis for the Project (see Section 5) but should not be considered mitigation measures at this point in the Project planning process. These actions are recommended prior to Project implementation:

BIO-1 Rare Plant Surveys: Rare plant surveys should be conducted within suitable habitat within the Project Area during the appropriate blooming period for the Abrams' spurge (approximately September through November), Wiggins' croton (approximately March through May), and sand food (approximately April through June). The surveys should be conducted by a botanist or qualified biologist in accordance with the USFWS Guidelines for Conducting and Reporting Botanical Inventories for Federally Listed, Proposed, and Candidate Plants (USFWS 1996); the CDFW Protocols for Surveying and Evaluating Impacts to Special Status Native Plant Populations and Sensitive Natural Communities (CDFW 2018); and the CNPS Botanical Survey Guidelines (CNPS 2001). If any special-status species are observed during the rare plant surveys, the location of the individual plant or population will be recorded with a submeter GPS device for mapping purposes. If Project-related impacts to rare plants within the Project Area are unavoidable, then consultation with CDFW may be required to develop a mitigation plan or additional avoidance and minimization measures. Mitigation measures that may be implemented if the species is observed include establishing a no-disturbance buffer around locations of individuals or a population, salvage or seed collection, and additional monitoring requirements.

BIO-2 Biological Monitoring: A qualified biologist should be present to monitor all ground-disturbing and vegetation-clearing activities conducted for the Project. During each monitoring day, the biological

monitor should perform clearance survey “sweeps” at the start of each work day that vegetation clearing takes place to minimize impacts on special-status species with potential to occur (including, but not limited to, special-status and/or nesting bird species and flat-tailed horned lizard). The monitor will be responsible for ensuring that impacts to special-status species, nesting birds, and active nests will be avoided to the greatest extent possible. Biological monitoring should take place until the Project Area has been completely cleared of any vegetation. If an active nest is identified, the biological monitor should establish an appropriate disturbance limit buffer around the nest using flagging or staking. Construction activities should not occur within any disturbance limit buffer zones until the nest is deemed no longer active by the biologist. If special-status wildlife species are detected during biological monitoring activities, then consultation with the USFWS and/or CDFW should be conducted and a mitigation plan should be developed to avoid and offset impacts to these species. Mitigation measures may consist of work restrictions or additional biological monitoring activities after ground-disturbing activities are complete.

BIO-3 Pre-Construction Surveys for Burrowing Owl: Pre-construction surveys for burrowing owl should be conducted within the Project Area and adjacent areas prior to the start of ground-disturbing activities. The surveys should follow the methods described in the CDFW's *Staff Report on Burrowing Owl Mitigation* (CDFG 2012). Two surveys should be conducted, with the first survey being conducted between 30 and 14 days before initial ground disturbance (grading, grubbing, and construction), and the second survey being conducted no more than 24 hours prior to initial ground disturbance. If burrowing owls and/or suitable burrowing owl burrows with sign (e.g., whitewash, pellets, feathers, prey remains) are identified within the Project Area during the survey and impacts to those features are unavoidable, consultation with the CDFW should be conducted and the methods described in the CDFW's *Staff Report on Burrowing Owl Mitigation* (CDFG 2012) for avoidance and/or passive relocation should be followed.

BIO-4 Pre-Construction Nesting Bird Survey: If construction or other Project activities are scheduled to occur during the bird breeding season (typically February 1 through August 31 for raptors and March 15 through August 31 for the majority of migratory bird species), a pre-construction nesting-bird survey should be conducted by a qualified avian biologist to ensure that active bird nests, including those for the black-tailed gnatcatcher, northern harrier, yellow warbler, burrowing owl, and loggerhead strike, will not be disturbed or destroyed. The survey should be completed no more than three days prior to initial ground disturbance. The nesting-bird survey should include the Project Area and adjacent areas where Project activities have the potential to affect active nests, either directly or indirectly due to construction activity or noise. If an active nest is identified, the biologist should establish an appropriately sized disturbance-limit buffer around the nest using flagging or staking. Construction activities should not occur within any disturbance-limit buffer zones until the nest is deemed inactive by the qualified biologist. If construction activities cease for a period of greater than three days during the bird breeding season, a pre-construction nesting bird survey should be conducted prior to the commencement of activities.

BIO-5 Pre-Construction Survey for Special-Status Species: A pre-construction survey should be conducted for special-status wildlife species within all areas of potential permanent and temporary disturbance. The pre-construction survey should take place no more than 14 days prior to the start of ground-disturbing activities. The pre-construction surveys should take place regardless of breeding

season timing and should focus on identifying the presence of special-status wildlife species present within the Project Area or that were identified as having a high potential to occur on the site. These species include, but are not limited to, flat-tailed horned lizard, burrowing owl, northern harrier, black-tailed gnatcatcher, and yellow warbler. Should any special-status species be identified during the pre-construction survey, consultation to develop suitable avoidance and minimization measures with the appropriate agency (USFWS, CDFW) may need to be undertaken.

BIO-6 Aquatic Resources Regulatory Permitting: If Project-related impacts occur to the riparian areas that may also fall under the jurisdiction of the USACE, CDFW, RWQCB a regulatory permit with those agencies is needed prior to the impact occurring. Refer to the ECORP Jurisdiction Delineation Report (2022) for preliminary determination of regulatory limits that areas that may be regulated by USACE, CDFW, or SWRCB. Permitting includes preparation and submittal of a Pre-Construction Notification under Section 404 of the federal CWA, an Application for Water Quality Certification under Section 401 of the federal CWA and a Notification of Lake or Streambed Alteration under Section 1600 of the California Fish and Game Code. Other items such as finalized project plans, quantities of fill material, supporting technical studies, etc., are also submitted along with the applications. As a part of this process, the project must also identify and approve mitigation through the respective agencies. Mitigation can include onsite or offsite options or could include payment of an in-lieu fee to a conservation organization. Types of mitigation can include restoration, creation, rehabilitation, enhancement, or other types of habitat improvement. Typically, the type of mitigation and acreage of mitigation is negotiated with the regulatory agencies during the permitting process.

BIO-7 Wetland/Riparian Habitat Avoidance: To the greatest extent possible, plans should avoid impacts to arrow weed thicket (disturbed) and tamarisk thicket habitats to minimize potential impacts to special-status species. Excluding these habitats from the Project should also minimize mitigation and permitting requirements to meet the less-than-significance threshold.

BIO-8 Minimization of Impacts to Wetland/Riparian Habitat: Solar panels, structures, and new access roads should not be placed within 50 feet of wetland and riparian habitat boundaries. A construction buffer of 300 feet should be established around the wetlands and riparian habitat during bird breeding season (February 1 – August 31). Prior to construction, fencing should be installed approximately 10 feet from the wetland and riparian habitat boundaries within 50 feet of the Project. Fencing should be easily visible to construction.

The following best management practices are not mitigation measures pursuant to CEQA but are recommended to further reduce impacts to special-status species that have potential to occur on the property:

- Confine all work activities to a pre-determined work area.
- To prevent inadvertent entrapment of wildlife during the construction phase of the Project, all excavated, steep-walled holes or trenches more than two feet deep should be covered at the close of each working day by plywood or similar materials. If the trenches cannot be closed, one or more escape ramps constructed of earthen fill or

wooden planks should be installed. Before such holes or trenches are filled, they should be thoroughly inspected for trapped animals.

- Wildlife are often attracted to burrow- or den-like structures such as pipes, and may enter stored pipes and become trapped or injured. To prevent wildlife use of these structures, all construction pipes, culverts, or similar structures with a diameter of four inches or greater should be capped while stored onsite.
- All food-related trash items such as wrappers, cans, bottles, and food scraps should be disposed of in securely closed containers and removed at least once a week from a construction or Project Area.
- Use of rodenticides and herbicides within the Project Area should be restricted. This is necessary to prevent primary or secondary poisoning of wildlife, including burrowing owl and the depletion of prey populations on which they depend. All uses of such compounds should observe label and other restrictions mandated by the USEPA, California Department of Food and Agriculture, and other state and federal legislation. If rodent control must be conducted, zinc phosphide should be used because of a proven lower risk to burrowing owl.

BIO-9 Compliance with Section 4150 of California Fish and Game Code: To avoid impacts to bat species, a qualified bat biologist should conduct an appropriate combination of sampling, exit counts, and acoustic surveys to determine if bats are using the palm tree resources in the Project Area. If Project-related impacts to bat species are unavoidable, additional measures may need to be implemented to reduce or eliminate impacts to bat species, including maternity roosts, such as tree removal occurring outside of bat breeding season (October through February) or two-step, two-day removal of palm trees under supervision of a qualified bat biologist.

7.0 CERTIFICATION

I hereby certify that the statements furnished above and in the attached exhibits present the data and information required for this biological evaluation, and that the facts, statements, and information presented are true and correct to the best of my knowledge and belief. Field work conducted for this assessment was performed by me or under my direct supervision. I certify that I have not signed a non-disclosure or consultant confidentiality agreement with the project applicant or the applicant's representative and that I have no financial interest in the project.

Signed: _____ Date: July 14, 2022
Caroline Garcia
Associate Biologist

Signed: _____ Date: July 14, 2022
Christina Torres
Associate Biologist

8.0 REFERENCES

- AOU. 2022. Check-list of North American Birds. Available online: <http://www.aou.org>.
- Baldwin, B. G., D. H. Goldman, D. J. Keil, R. Patterson, T. J. Rosatti, and D. H. Wilken, editors. 2012. The Jepson Manual: Vascular Plants of California, Second Edition. University of California Press, Berkeley, California. 1400 pp.
- Bradley, R.D., L.K. Ammerman, R.J. Baker, L.C. Bradley, J.A Cook, R.C. Dowler, C. Jones, D.J Schmidly, F.B. Stangl, Jr., R.A. Van Den Bussche, B. Wursig. 2014. Revised Checklist of North American Mammals North of Mexico. Museum of Texas Tech University.
- CalFlora: Information on California plants for education, research and conservation. [Web application]. 2022. Berkeley, California: The CalFlora Database [a non-profit organization]. Available online: <http://www.calflora.org>.
- CDFG. 2012. Staff Report on Burrowing Owl Mitigation. Dated March 7, 2012.
- _____. 1984. California Endangered Species Act. California Code of Regulations, Title 14, Chapter 5, Section 460. California Office of Administrative Law. Sacramento, CA.
- CDFW. 2022a. California Native Diversity Database. Rarefind 5 [computer program]. Sacramento (CA): State of California, the Resources Agency, Department of Fish and Wildlife. Accessed on September 14, 2020 and April 5, 2022.
- _____. 2022b. Special Animals List. Sacramento (CA): State of California, the Resources Agency, Department of Fish and Wildlife.
- _____. 2022c. State and Federally Listed Endangered and Threatened Animals of California. Sacramento (CA): State of California, Natural Resources Agency, Department of Fish and Wildlife. Dated April 2022.
- CDFW. 2018. Protocols for Surveying and Evaluating Impacts to Special Status Native Plant Populations and Sensitive Natural Communities. Sacramento, California.
- CNPS. 2022. Inventory of Rare and Endangered Plants (online edition, v7-08c). Rare Plant Scientific Advisory Committee. California Native Plant Society. Sacramento, CA. Available online: <http://www.cnps.org/inventory>.
- _____. 2001. Inventory of Rare and Endangered Plants of California (sixth edition). Rare Plant Scientific Advisory Committee, David P. Tibor, Convening Editor. California Native Plant Society, Sacramento, CA. 388pp.
- ECORP. 2022. Jurisdictional Delineation Report for the Vega SES 4 Solar Project. Prepared for Vega SES 4, LLC., San Diego, California. November 2020 rev. April 2022.
- County of Imperial, Planning and Development Services Department. 2006. Imperial County Conservation and Open Space Element, El Centro, CA.

- Holland, R. 1986. Preliminary Descriptions of the Terrestrial Natural Communities of California. Department of Fish and Game, Sacramento, CA.
- NRCS. 2022a. Online Web Soil Survey. U.S. Department of Agriculture. Accessed on September 27, 2020. Available online: <http://websoilsurvey.nrcs.usda.gov>.
- NRCS. 2022b. Soil Data Access Hydric Soils List. Available at <https://www.nrcs.usda.gov/wps/portal/nrcs/main/soils/use/hydric/>. Accessed September 20, 2020.
- Oberbauer, Thomas, Meghan Kelly, and Jeremy Buegge. March 2008. Draft Vegetation Communities of San Diego County. Based on "Preliminary Descriptions of the Terrestrial Natural Communities of California", Robert F. Holland, Ph.D., October 1986.
- Sawyer, J. O., T. Keeler-Wolf, and J. M. Evens. 2009. A Manual of California Vegetation, 2nd ed. California Native Plant Society, Sacramento, CA.
- Skinner, M. W., and Pavlik (eds.). 1994. Inventory of Rare and Endangered Vascular Plants of California; Fifth Edition. California Native Plant Society, Sacramento, California.
- SSAR. 2017. Scientific and Standard English Names of Amphibians and Reptiles of North American North of Mexico, With Comments Regarding Confidence in our Understanding. Eighth Edition. Committee on Standard English and Scientific Names.
- USFWS. 2022a. National Wetland Inventory. <https://www.fws.gov/wetlands/data/Mapper.html>. Accessed on September 24, 2020 and April 22, 2022.
- _____. 2022b. IPAC Trust Resources List. <http://ecos.fws.gov/ipac/>. Accessed on September 24, 2020 and April 26, 2022.
- _____. 1996. USFWS Guidelines for Conducting and Reporting Botanical Inventories for Federally Listed, Proposed, and Candidate Plants.
- _____. 1918. Migratory Bird Treaty Act of 1918. Section 16 of the U.S. Code (703-712), as amended 1989.

LIST OF ATTACHMENTS

Attachment A – Representative Site Photographs

Attachment B – Special-Status Plant Potential For Occurrence

Attachment C – Special-Status Wildlife Potential For Occurrence

ATTACHMENT A

Representative Site Photographs

Attachment A: Representative Site Photographs



Photo 1. Southeastern section of the Project Area in disturbed lands, facing northeast.



Photo 2. Northeastern section of the Project Area in disturbed creosote bush – white bursage scrub habitat, facing west.



Photo 3. Disturbed arrow weed scrub with tamarisk thickets in the background (circled in red) of the Project Area facing west.



Photo 4. Edge of tamarisk thickets in Project Area, facing west.



Photo 5. View of creosote bush scrub in the western section of the Project Area, facing west.



Photo 6. Close-up view of active burrowing owl burrow with whitewash and pellets near entrance, located in the southwestern section of the Project Area, facing southwest.



Photo 7. View of All-American Canal (within the northern buffer of the Project Area) lined with riparian vegetation, including arrow weed and tamarisk thickets, facing northwest.



Photo 8. View of U.S. Mexico border wall lining the southern perimeter of the Project Area, facing south.

Attachment A: Representative Site Photographs



Photo 9. View of creosote bush – white bursage scrub north of the access road, facing northwest.



Photo10. View of disturbed creosote bush scrub north of the bridge that crosses the All-American Canal that connects to the access road, facing west.



Photo 11. View of active cliff swallow mud nests on the Gordon Wells Road bridge crossing the offline storage canal for the All-American Canal, facing southeast.



Photo 12. View of the crevice housing a bat colony within the Gordon Wells Road bridge crossing the offline storage canal for the All-American Canal.

Attachment A: Representative Site Photographs



Photo 13. View of tamarisk thickets adjacent to the access road, facing northwest.



Photo 14. View of the access road, facing northeast.

Special-Status Plant Potential For Occurrence

Special-Status Plant Species Potential For Occurrence				
Scientific Name Common Name	Status	Blooming Period/ Elevation Range (meters)	Habitat	Potential to Occur in the Project site
<i>Amaranthus watsonii</i> Watson's amaranth	USFWS: None CDFW: None CRPR: 4.3	Apr-Sep (20 - 1700)	Mojavean desert scrub Sonoran desert scrub	Low: Habitat for this species occurs within the Project site. No CNDDDB records occur within 5 miles of the site.
<i>Astragalus magdalenae</i> var. <i>peirsonii</i> Peirson's milk-vetch	USFWS: Threatened CDFW: Endangered CRPR: 1B.2	Dec-Apr (60 - 225)	Desert dunes	Low: No habitat occurs within the Project site. One recent (2018) CNDDDB record occurs to the northeast, but not within 5 miles of the site.
<i>Astragalus sabulorum</i> gravel milk-vetch	USFWS: None CDFW: None CRPR: 2B.2	Feb-Jun (-60 - 930)	Desert dunes Mojavean desert scrub Sonoran desert scrub	Low: Habitat for this species occurs within the Project site. No CNDDDB records occur within 5 miles of the site.
<i>Croton wigginsii</i> Wiggins' croton	USFWS: None CDFW: Rare CRPR: 2B.2	Mar-May (50 - 100)	Desert dunes Sonoran desert scrub	Moderate: Habitat for this species occurs within the Project site. One recent CNDDDB record occurs from 2019 but is not within 5 miles of the site. Two historic CNDDDB records occur within 5 miles; the closest is located 0.92 miles east of the site from 1993.
<i>Euphorbia abramsiana</i> Abrams' spurge	USFWS: None CDFW: None CRPR: 2B.2	Sep-Nov (-5 - 1310)	Mojavean desert scrub Sonoran desert scrub	Moderate: Habitat for the species occurs within the Project site and a historic CNDDDB record (2010) occurs approximately three miles west of the site.
<i>Helianthus niveus</i> ssp. <i>tephrodes</i> Algodones Dunes sunflower	USFWS: None CDFW: Endangered CRPR: 1B.2	Sep-May (50 - 100)	Desert dunes	Low: No habitat occurs within the Project site. One recent observation of this species has occurred within approximately two miles of the Project site in 2018.
<i>Imperata brevifolia</i> California satintail	USFWS: None CDFW: None CRPR: 2B.1	Sep-May (0 - 1215)	Chaparral Coastal scrub Mojavean desert scrub Meadows and seeps Riparian scrub	Low: Habitat for this species occurs within the Project site. No CNDDDB records occur within 5 miles of the site.
<i>Johnstonella costata</i> ribbed cryptantha	USFWS: None CDFW: None CRPR: 4.3	Feb-May (-60 - 500)	Desert dunes Mojavean desert scrub Sonoran desert scrub	Low: Habitat for this species occurs within the Project site. No CNDDDB records occur within 5 miles of the site.

Special-Status Plant Species Potential For Occurrence				
Scientific Name Common Name	Status	Blooming Period/ Elevation Range (meters)	Habitat	Potential to Occur in the Project site
<i>Johnstonella holoptera</i> winged cryptantha	USFWS: None CDFW: None CRPR: 4.3	Mar-Apr (100 - 1690)	Mojavean desert scrub Sonoran desert scrub	Low: Habitat for this species occurs within the Project site. No CNDDDB records occur within 5 miles of the site.
<i>Mentzelia hirsutissima</i> hairy stickleaf	USFWS: None CDFW: None CRPR: 4.3	Mar-May (0 - 700)	Sonoran desert scrub	Low: Habitat for this species occurs within the Project site. No CNDDDB records occur within 5 miles of the site.
<i>Mentzelia puberula</i> Darlington's blazing star	USFWS: None CDFW: None CRPR: 2B.2	Mar-May (90 - 1280)	Mojavean desert scrub Sonoran desert scrub	Low: Habitat for this species occurs within the Project site. No CNDDDB records occur within 5 miles of the site.
<i>Nemacaulis denudata</i> var. <i>gracilis</i> slender cottonheads	USFWS: None CDFW: None CRPR: 2B.2	Apr-May (-50 - 400)	Coastal dunes Desert dunes Sonoran desert scrub	Low: Habitat for this species occurs within the Project site. No CNDDDB records occur within 5 miles of the site.
<i>Palafoxia arida</i> var. <i>gigantea</i> giant Spanish-needle	USFWS: None CDFW: None CRPR: 1B.3	Feb-May (15 - 100)	Desert dunes	Low: No habitat occurs within the Project site. One recent CNDDDB record occurs from 2013 but is not within 5 miles of the site. Two historic CNDDDB records occur within 5 miles of the site; the closest record is 0.4 miles north of the site from 1938 within sand dunes.
<i>Pholisma sonorae</i> sand food	USFWS: None CDFW: None CRPR: 1B.2	Apr-Jun (0 - 200)	Desert dunes Sonoran desert scrub	Moderate: Habitat for this species occurs within the Project site. One recent CNDDDB record occurs from 2018 but is not within 5 miles of the site. One historic CNDDDB record occurs within 5 miles of the Project site located 0.5 miles north of the site from 1954.

California Native Plant Society (CNPS) Rare Plant Ranks:

1B: Plants rare, threatened, and endangered in California and elsewhere.

2B: Plants rare, threatened, or endangered in California, but more common elsewhere.

4: Plants of limited distribution; a watch list.

CNPS Threat Ranks:

0.1: Seriously threatened in California (over 80% of occurrences threatened / high degree and immediacy of threat)

0.2: Fairly threatened in California (20-80% of occurrences threatened / moderate degree and immediacy of threat)

0.3-Not very threatened in California (less than 20% of occurrences threatened / low degree and immediacy of threat or no current threats known)

Sources:

California Natural Diversity Data Base (CNDDDB) (CDFW 2022)

CNPS Rare and Endangered Plant Inventory (CNPS 2022)

Calflora Information on California Plants (Calflora 2022)

IPaC (USFWS 2022)

Special-Status Wildlife Potential For Occurrence

Special-Status Wildlife Species Potential For Occurrence

Scientific Name Common Name	Status	Habitat Requirements	Potential for Occurrence
AMPHIBIANS			
BUFONIDAE (true toads)			
<i>Incilius alvarius</i> Sonoran Desert toad	USFWS: CDFW:	none SSC	Creosote bush desert scrub, grasslands up into oak-pine woodlands, thorn scrub and tropical deciduous forest in Mexico. Low. Limited suitable habitat within the buffer adjacent to the canal. No CNDDDB records occur within 5 miles of the site.
REPTILES			
PHRYNOSOMATIDAE (spiny lizards)			
<i>Phrynosoma mcallii</i> flat-tailed horned lizard	USFWS: CDFW:	none SSC	Desert scrub on sandy flats and valleys with little or no windblown sand, salt flats, and areas with gravelly soils. High. Suitable habitat on the Project site. Four recent CNDDDB records occur within 5 miles of the site. The closest recorded occurrence is less than 1 mile north of the site from 2014.
VIPERIIDAE (vipers)			
<i>Crotalus ruber</i> red-diamond rattlesnake	USFWS: CDFW:	none SSC	Found in coastal chaparral, arid scrub, rocky grassland, oak and pine woodlands, desert mountain slopes and rocky desert flats. Low. Marginally suitable habitat on the Project site. No CNDDDB records occur within 5 miles of the site.
BIRDS			
ACCIPITRIDAE (hawks, kites, harriers, and eagles)			
<i>Circus hudsonius</i> northern harrier	USFWS: CDFW:	none SSC	Undisturbed tracts of grasslands and wetlands with low, thick vegetation. Prefers to breed in dry upland habitats, old fields, grazed meadows, drained marshlands, and high-desert shrubsteppe. Also found in pasturelands, croplands, and open floodplains. Present. There was one sighting of northern harrier within the Project site. No CNDDDB records occur within 5 miles of the site.
ALAUDIDAE (larks)			
<i>Eremophila alpestris ssp. actia</i> California horned lark	USFWS: CDFW:	none WL	Bare open areas dominated by low vegetation or widely scattered shrubs, includes prairies, deserts, and plowed fields. Nests in a hollow on the ground. Moderate. The open areas of the Project site and within the buffer provide suitable habitat. No CNDDDB records occur within 5 miles of the site.
LANIIDAE (shrikes)			
<i>Lanius ludovicianus</i> loggerhead shrike (nesting)	USFWS: CDFW:	BCC SSC	Open country, with scattered shrubs and trees or other perches for hunting; includes agricultural fields, deserts, grasslands, savanna, and chaparral. Nests 2.5 to 4 feet off ground in thorny vegetation. Present. This species was observed within the tamarisk thickets in the western section of the Project site and within the creosote bush scrub adjacent to the access road. There is suitable nesting habitat within the Project site.

PARULIDAE (new world warblers)				
<i>Icteria virens</i> yellow-breasted chat	USFWS: CDFW:	none SSC	Riparian and upland thickets, and dry overgrown pastures. Prefers to nest in dense scrub along streams or at the edges of ponds or swamps.	Moderate. The dense arrow weed and tamarisk thickets within the Project site provide suitable nesting and foraging habitat for this species. No CNDDDB records occur within 5 miles of the site.
<i>Setophaga petechia</i> yellow warbler	USFWS: CDFW:	BCC SSC	Riparian woodlands especially with willows, open scrub, gardens, and thickets often near water.	Present. This species was observed within the tamarisk thickets in the western buffer of the Project site. This habitat provides suitable foraging and nesting areas for this species. No CNDDDB records occur within 5 miles of the site.
PICIDAE (woodpeckers)				
<i>Melanerpes uropygialis</i> Gila woodpecker	USFWS: CDFW:	none END	Arid environments, especially deserts and dry forests of the southwestern U.S. and adjacent Mexico, usually below elevations of 3,300 feet. Most common in low swales and arroyos, including riparian corridors with cottonwood, willow, and mesquite. Nests in cacti and other tree species.	Presumed Absent. Unlikely to occur onsite due to absence of suitable nesting cavity locations, i.e. large trees and/or cacti. No recent CNDDDB records occur within 5 miles of the site.
POLIOPTILIDAE (gnatcatchers)				
<i>Poliophtila melanura</i> black-tailed gnatcatcher	USFWS: CDFW:	none WL	Semiarid and desert thorn scrub habitats. This species is well adapted to dry habitats and tend to be most common in areas with less than 8 inches of annual rainfall. They often live far from streams and other bodies of water.	Present. A pair was observed in the tamarisk thickets in the southwestern buffer of the Project. Tamarisk thickets are suitable foraging and nesting habitat for this species. No CNDDDB records occur within 5 miles of the site.
RALLIDAE (rails)				
<i>Laterallus jamaicensis ssp. coturniculus</i> California black rail	USFWS: CDFW:	BCC THR, FP	Riparian marshes, coastal prairies, saltmarshes, and impounded wetlands. All of its habitats have stable shallow water, usually just 1.2 inches deep at most.	Moderate. Moderately suitable nesting and foraging habitat for this species is present within the buffer of the Project site adjacent to the canal. One recent CNDDDB record occurs approximately 1 mile northeast of the site, directly north of the access road where individuals were detected within emergent wetland vegetation adjacent to the All-American Canal in 2008. Emergent wetland vegetation included seep wetlands characterized by bulrush, cattails, common reed, and scattered willows. A wetland enhancement project is underway in the area.

<i>Rallus obsoletus ssp. yumanensis</i> Yuma Ridgway's rail	USFWS: CDFW:	END THR, FP	Consistently found in freshwater marshes that are composed of cattail and bulrush. This emergent vegetation averages greater than 6 feet tall. Water depth tends to be around 3.5 inches deep. Range extends from Nevada, California, and Arizona to Baja California and Sonora Mexico.	Moderate. Presence of cattail dominated wetland habitat within the tamarisk and arrow weed thickets on the Project site are suitable foraging habitats for this species, however area lack consistent water The All-American Canal within the buffer of the Project site provides suitable habitat. Three CNDDDB records occur within 5 miles of the site. The most recent record occurs approximately 1 mile northeast of the site, directly north of the access road from 2008. The species was found within the All-American Canal.
TYRANNIDAE (tyrant flycatchers)				
<i>Empidonax traillii ssp. extimus</i> southwestern willow flycatcher	USFWS: CDFW:	END END	Riparian woodlands particularly with willow thickets. Nests in densest areas of shrubs and trees with low-density canopies.	Low. Suitable tamarisk and arrow weed riparian woodland habitat on the Project site but no presence of willows. No CNDDDB records within 5 miles of the site.
STRIGIDAE (owls)				
<i>Athene cunicularia</i> burrowing owl	USFWS: CDFW:	none SSC	Open grasslands including prairies, plains, and savannah, or vacant lots and airports. Nests in abandoned dirt burrows.	Present. A burrowing owl and two active satellite burrows were observed during the habitat assessment. Eight CNDDDB records within 5 miles of the site; two historic records and six recent records with the closest being 1.7 miles away in 2007.
MAMMALS				
MOLOSSIDAE (free-tailed bats)				
<i>Eumops perotis ssp. californicus</i> western mastiff bat	USFWS: CDFW:	none SSC	Roosts high above ground in rock and cliff crevices, shallow caves, and rarely in buildings. Occurs in arid and semiarid regions including rocky canyon habitats.	Presumed Absent. No suitable roosting habitat within site or in buffer. No CNDDDB records within 5 miles of the site.
<i>Nyctinomops macrotis</i> big free-tailed bat	USFWS: CDFW:	none SSC	Roosts in cliff crevices, and less often in buildings, caves, and tree cavities. Occurs in rocky areas of rugged and hilly country including woodlands, evergreen forests, river floodplain-arroyo habitats, and desert scrub.	Presumed Absent. No suitable roosting habitat within site or in buffer. No CNDDDB records within 5 miles of the site.
VESPERTILIONIDAE (evening bats)				
<i>Antrozous pallidus</i> pallid bat	USFWS: CDFW:	none SSC	Roosts in rock crevices, caves, mines, buildings, bridges, and in trees. Generally, in mountainous areas, lowland desert scrub, arid grasslands near water and rocky outcrops, and open woodlands.	Moderate. Suitable roosting habitat is present within the access road bridge over the offline storage reservoir, north of the All-American Canal. Additionally, desert scrub provides suitable foraging habitat. No CNDDDB records within 5 miles of the site.

<p><i>Corynorhinus townsendii</i> Townsend's big-eared bat</p>	<p>USFWS: CDFW:</p>	<p>none SSC</p>	<p>Roosts in mines, caves, buildings, or other crevices, sometimes trees. Usually requires large crevices. Most common in moist areas or those with access to water.</p>	<p>Moderate. Suitable roosting habitat is present within the access road bridge over the offline storage reservoir, north of the All-American Canal, additionally, desert scrub provides suitable foraging habitat. No CNDDDB records within 5 miles of the site.</p>
<p><i>Lasiurus xanthinus</i> western yellow bat</p>	<p>USFWS: CDFW:</p>	<p>none SSC</p>	<p>Roosts in trees, particularly palms, in desert wash, desert riparian, valley foothill riparian, and palm oasis habitats.</p>	<p>Moderate. Suitable roosting habitat is present within the palm trees of the Project site. This species has a strong association with roosting under dead palm frond skirts. No CNDDDB records within 5 miles of the site.</p>
<p><i>Myotis occultus</i> Arizona myotis</p>	<p>USFWS: CDFW:</p>	<p>none SSC</p>	<p>Roosts in bridges, buildings, tree snags. Most commonly found in high elevation conifer forests however maternity sites have been found at lower elevations within bridges and buildings</p>	<p>Moderate. Suitable roosting habitat is present within the access road over the offline storage reservoir, north of the All-American Canal. No CNDDDB records within 5 miles of the site.</p>
<p>CRICETIDAE (New World rats and mice)</p>				
<p><i>Sigmodon hispidus ssp. eremicus</i> Yuma hispid cotton rat</p>	<p>USFWS: CDFW:</p>	<p>none SSC</p>	<p>Inhabits a variety of habitats, but generally associated with drainage ditches, canals, and seeps vegetated with plants such as arrow weed, saltgrass, common reed, cattails, sedges, tamarisk, heliotrope, and annual grasses. They utilize runways through dense herbaceous growth and nests are built of woven grass. Noted presence in moist agricultural fields.</p>	<p>High. There is suitable habitat in the arrow weed and tamarisk thickets within the Project site. Two recent CNDDDB records occur less than 1 mile north of the access road for the site. This species was found in arrow weed scrub and freshwater marsh adjacent to the All-American Canal in 2007.</p>
<p>Federal Designations: (Federal Endangered Species Act, USFWS)</p> <p>END: Federally-listed, Endangered THR: Federally-listed, Threatened CAN: Federal Candidate Species FSC: Federal Species of Concern FPD: Federal Proposed for Delisting BCC: Bird of Conservation Concern</p>			<p>State Designations: (California Endangered Species Act, CDFW)</p> <p>END: State-listed, Endangered THR: State-listed, Threatened CAN: State Candidate Species SSC: California Species of Special Concern FP: Fully Protected Species WL: Watch List</p>	

Aquatic Resources Delineation

Vega SES 4 Solar Project

Imperial County, California

Prepared For:

Vega SES 4, LLC
604 Sutter Street
Suite 250
Folsom, California 95630
(916) 985-9461

Submitted by:

ECORP Consulting, Inc.
3838 Camino Del Rio North
Suite 370
San Diego, California 92108
(858) 279-4040

CONTENTS

1.0	INTRODUCTION	1
2.0	REGULATORY SETTING.....	12
2.1	Waters of the United States.....	12
2.1.1	Wetlands.....	12
2.1.2	Other Waters.....	12
2.2	Clean Water Act.....	12
2.3	Porter-Cologne Water Quality Act.....	13
2.4	California Fish and Game Code Section 1602.....	14
3.0	METHODS.....	15
3.1	Pre-Survey Investigations	15
3.2	Field Survey Investigation.....	15
3.3	Post-Processing	16
4.0	RESULTS.....	16
4.1	Existing Site Conditions	16
4.1.1	Vegetation Communities.....	17
4.1.2	Soils.....	18
4.1.3	National Wetland Inventory.....	19
4.1.4	Hydrology.....	38
4.2	Aquatic Resources	38
4.2.1	Wetlands.....	49
4.2.2	Other Aquatic Resources.....	49
4.2.3	Manmade Features.....	50
4.2.4	Associated Habitat.....	50
5.0	JURISDICTIONAL ASSESSMENT	51
6.0	CONCLUSION.....	51
7.0	REFERENCES.....	53

LIST OF TABLES

Table 1.	USGS Quadrangle Information.....	1
Table 2.	Summary of Federal, State, and Local Regulations.....	14
Table 3.	Rainfall Data Summary.....	17
Table 4.	Natural Resources Conservation Service Soil Types within the Study Area.....	19
Table 5.	Aquatic Resources within the Project.....	48

LIST OF FIGURES

Figure 1. Project Location and Vicinity 2

Figure 2. Site Plan..... 11

Figure 3. Natural Resources Conservation Service Soil Types..... 20

Figure 4. National Wetlands Inventory 29

Figure 5. Aquatic Resources Delineation 39

LIST OF ATTACHMENTS

- Attachment A – Driving Directions to Study Area
- Attachment B – OHWM and Wetland Determination Data Forms - Arid West
- Attachment C – Representative Site Photographs
- Attachment D – USACE ORM Aquatic Resources Table
- Attachment E – Digital Data

LIST OF ACRONYMS AND ABBREVIATIONS

°F	degrees Fahrenheit
CDFW	California Department of Fish and Wildlife
CFR	Code of Federal Regulations
CWA	Clean Water Act
ED	Ephemeral drainages
FEW	Freshwater emergent wetlands
FR	Federal Register
FSW	Freshwater forested/shrub wetlands
GIS	Geographic Information System
GPS	Global Positioning System
MW	Megawatt
NETROnline	Nationwide Environmental Title Research Online
NOAA	National Oceanic and Atmospheric Administration
NRCS	Natural Resources Conservation Service
NWI	National Wetlands Inventory
NWPR	Navigable Waters Protection Rule
OMBIL	Operations and Maintenance Business Information Link
OHWM	Ordinary high water mark
ORM	OMBIL Regulatory Module
PD	Perennial drainages
PJD	Preliminary Jurisdictional Delineation
Project	Vega SES 4 Solar Project

LIST OF ACRONYMS AND ABBREVIATIONS

RWQCB	Regional Water Quality Control Board
SAA	Streambed Alteration Agreement
SR	State Route
Study Area	Solar Project and 500-foot Buffer
sUAS	small unmanned aircraft system
SWRCB	State Water Resources Control Board
TNW	traditional navigable waters
USACE	U.S. Army Corps of Engineers
USEPA	U.S. Environmental Protection Agency
USGS	U.S. Geological Survey
WDR	Waste discharge regulations

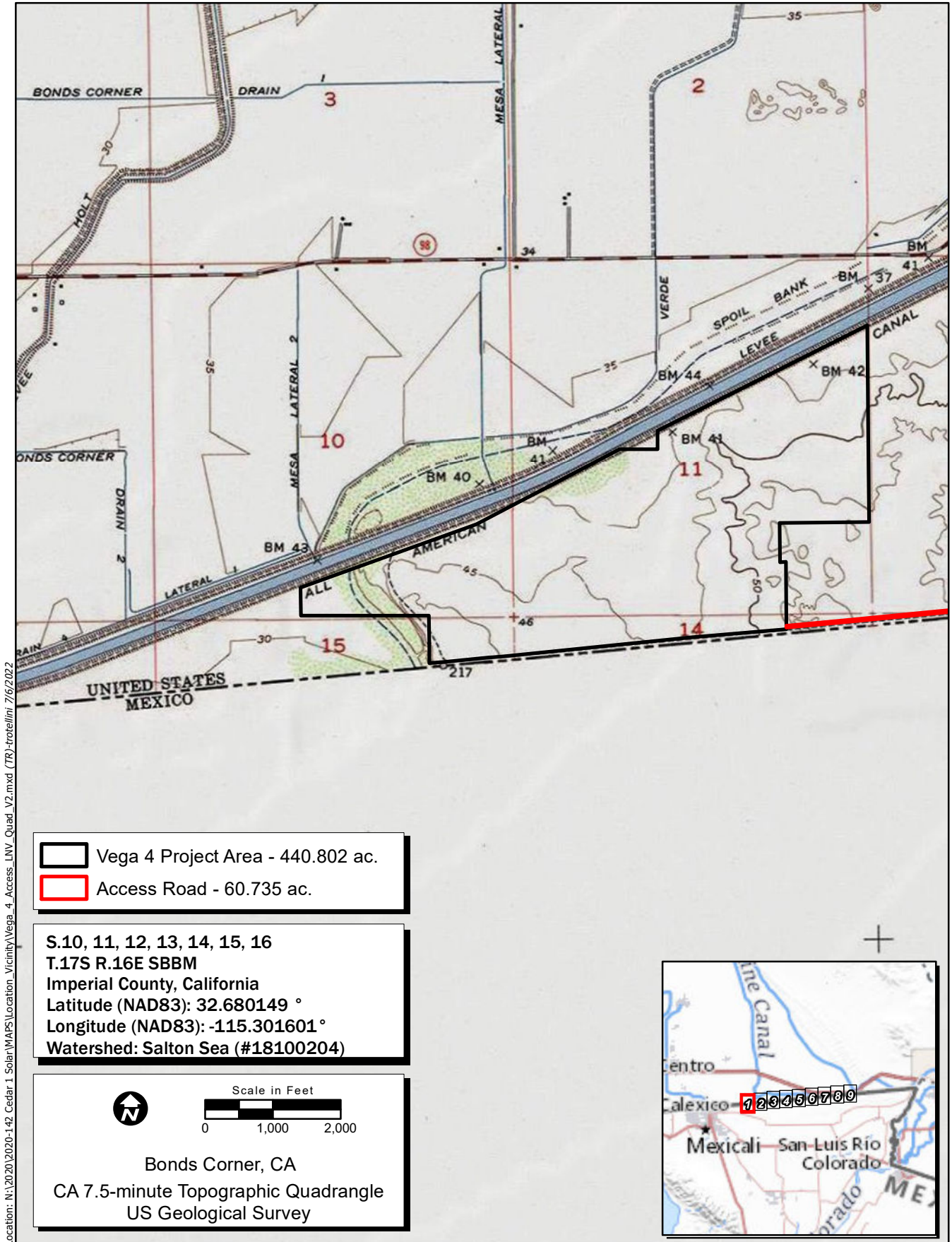
1.0 INTRODUCTION

This aquatic resources delineation report was prepared to describe the aquatic resources at the Vega SES 4 Solar Project (Project) located on ±511 acres of vacant land Imperial County, California. The Project includes a ±450-acre 100-Megawatt (MW) direct current and 400 MW-hour battery storage utility-scale solar project on two parcels (Assessor’s Parcel Numbers 059-300-015; 059-300-017). In addition, the Project includes a ±60-acre access road, totaling approximately 22 linear miles. For purposes of this report, “Study Area” refers to the solar field plus the access road, and a 150-foot buffer around each. The Project is within the southern portion of Imperial County, approximately nine miles southeast of Calexico, California and 0.5 mile south of California State Route (SR) 98. It resides in the middle of the All-American Canal to the north, and the U.S.-Mexico border, to the south. The access road runs east-west directly north and adjacent to the U.S./Mexico border wall (Figure 1. *Project Location and Vicinity*). A complete summary of geographic information for the Study Area is provided in Table 1. A map of the site is provided as Figure 2.

Table 1. USGS Quadrangle Information				
USGS 7.5-Minute Quad Map Name	Township	Range	Section(s)	Approximate Center of Study Area
Bonds Corner, CA (1976) Midway Well NW, CA (1979) Midway Well, CA (1979) Grays Well, CA (1976)	17S	16E 17E 18E 19E 20E	12, 13, 14 7, 8, 9, 10, 11, 12 1, 7, 8, 9, 10, 11, 12 1, 2, 3, 4, 5, 6 1, 6	32.682898, -115.304246

Driving directions to the Study Area are included as Attachment A. The Study Area is located on the south side of the All-American Canal and requires contacting U.S. Border Patrol prior to crossing the canal. After crossing the canal, turn right and follow the dirt access road along the canal for one mile.

This report describes aquatic resources identified within the Study Area that may be regulated by the Porter-Cologne Water Quality Act, California Fish and Game Code Sections 1600 and 1602, and the U.S. Army Corps of Engineers (USACE) pursuant to Sections 401 and 404 of the federal Clean Water Act (CWA). The information presented in this report provides data required by the USACE Los Angeles District’s Minimum Standards for Acceptance of Aquatic Resources Delineation Reports (USACE 2017). The aquatic resource boundaries depicted in this report represent a calculated estimation of the jurisdictional area within the Study Area and are subject to modification following the USACE verification process.



Location: N:\2020\2020-142_Cedar_1_Solar\WAPS\Location_Vicinity\Vega_4_Access_LNV_Quad_V2.mxd (TR):trc\l\m\ 7/6/2022

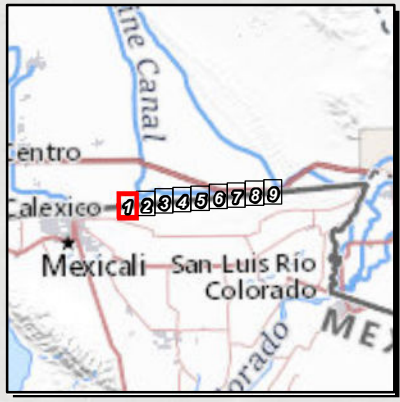
- Vega 4 Project Area - 440.802 ac.
- Access Road - 60.735 ac.

S.10, 11, 12, 13, 14, 15, 16
 T.17S R.16E SBBM
 Imperial County, California
 Latitude (NAD83): 32.680149 °
 Longitude (NAD83): -115.301601 °
 Watershed: Salton Sea (#18100204)

Scale in Feet

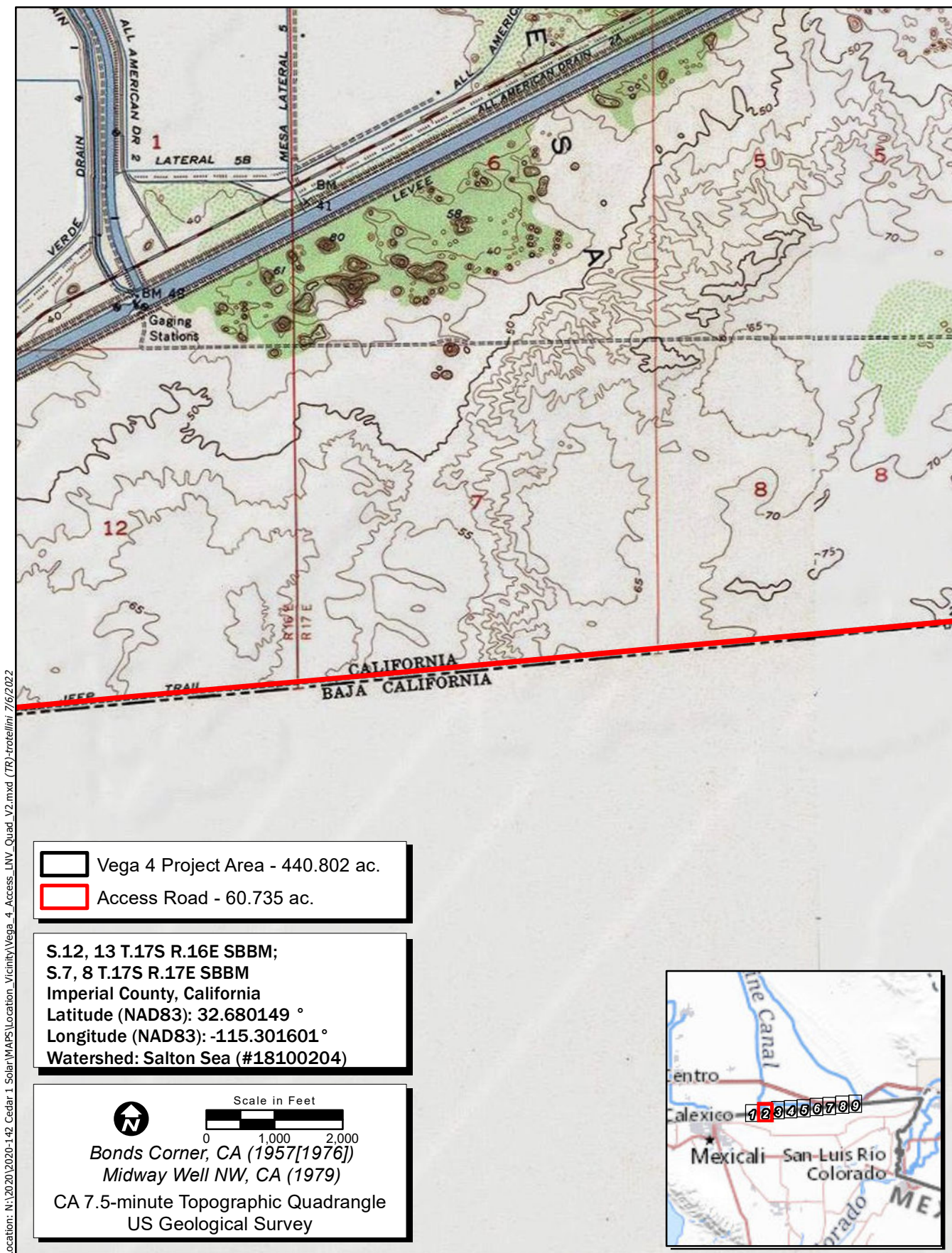
0 1,000 2,000

Bonds Corner, CA
 CA 7.5-minute Topographic Quadrangle
 US Geological Survey



Map Date: 7/6/2022
 Service Layer Credits: Copyright © 2013 National Geographic Society, i-cubed

Figure 1. Project Location and Vicinity
Sheet 1 of 9



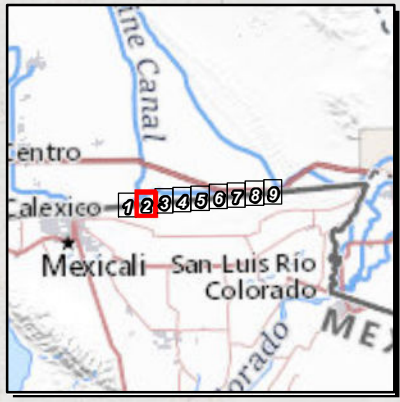
Location: N:\2020\2020-142_Cedar_1_Solar\WAPS\Location_Vicinity\Vega_4_Access_LNV_Quad_V2.mxd (TR) trocillini 7/6/2022

- Vega 4 Project Area - 440.802 ac.
- Access Road - 60.735 ac.

S.12, 13 T.17S R.16E SBBM;
S.7, 8 T.17S R.17E SBBM
 Imperial County, California
 Latitude (NAD83): 32.680149 °
 Longitude (NAD83): -115.301601 °
 Watershed: Salton Sea (#18100204)

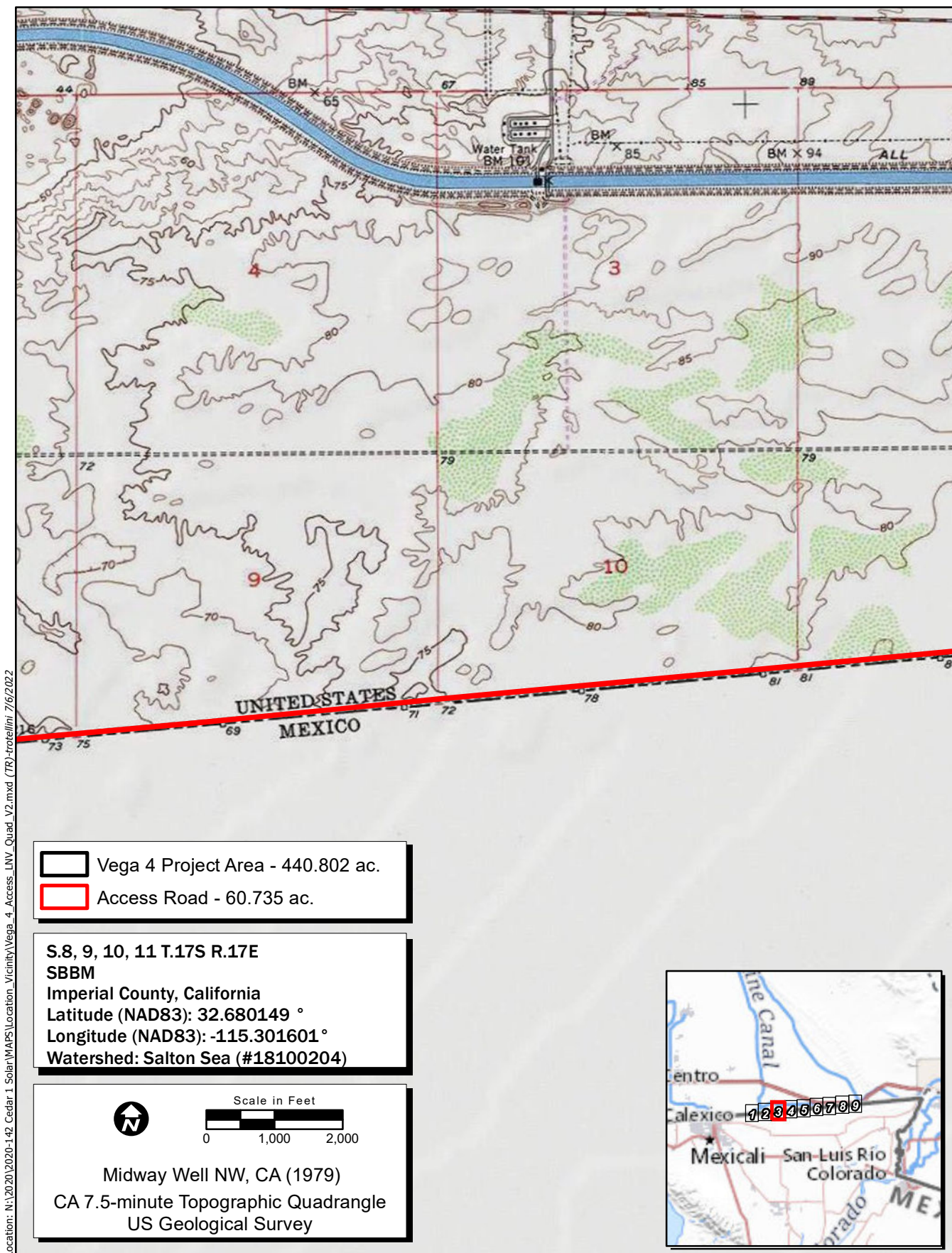
Scale in Feet

Bonds Corner, CA (1957[1976])
Midway Well NW, CA (1979)
 CA 7.5-minute Topographic Quadrangle
 US Geological Survey



Map Date: 7/6/2022
 Service Layer Credits: Copyright © 2013 National Geographic Society, i-cubed

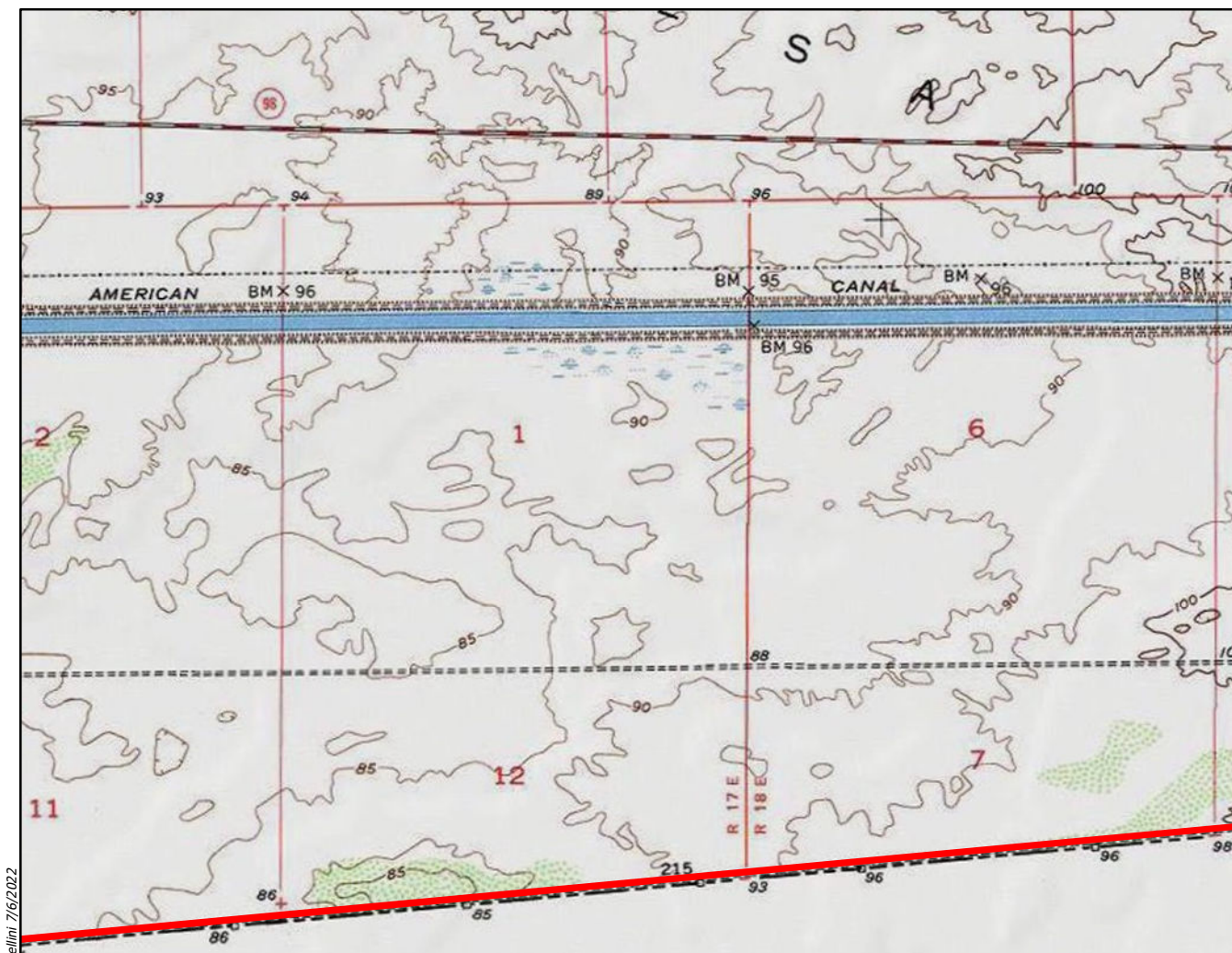
Figure 1. Project Location and Vicinity
Sheet 2 of 9



Location: N:\2020\2020-142_Cedar_1_Solar\WAPS\Location_Vicinity\Vega_4_Access_LNW_Quad_V2.mxd (TR) trocailini 7/6/2022

Map Date: 7/6/2022
 Service Layer Credits: Copyright © 2013 National Geographic Society, i-cubed

Figure 1. Project Location and Vicinity
Sheet 3 of 9



Location: N:\2020\2020-142_Cedar_1_Solar\WAPS\Location_Vicinity\Vega_4_Access_LNV_Quad_V2.mxd (TR) tracellini 7/6/2022

- Vega 4 Project Area - 440.802 ac.
- Access Road - 60.735 ac.

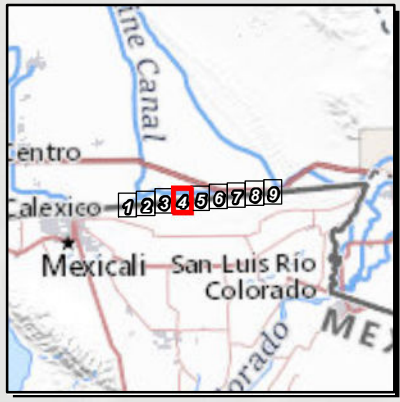
**S.11, 12 T.17S R.17E SBBM;
S.7, 8 T.17S R.18E SBBM
Imperial County, California
Latitude (NAD83): 32.680149 °
Longitude (NAD83): -115.301601 °
Watershed: Salton Sea (#18100204)**

N

Scale in Feet

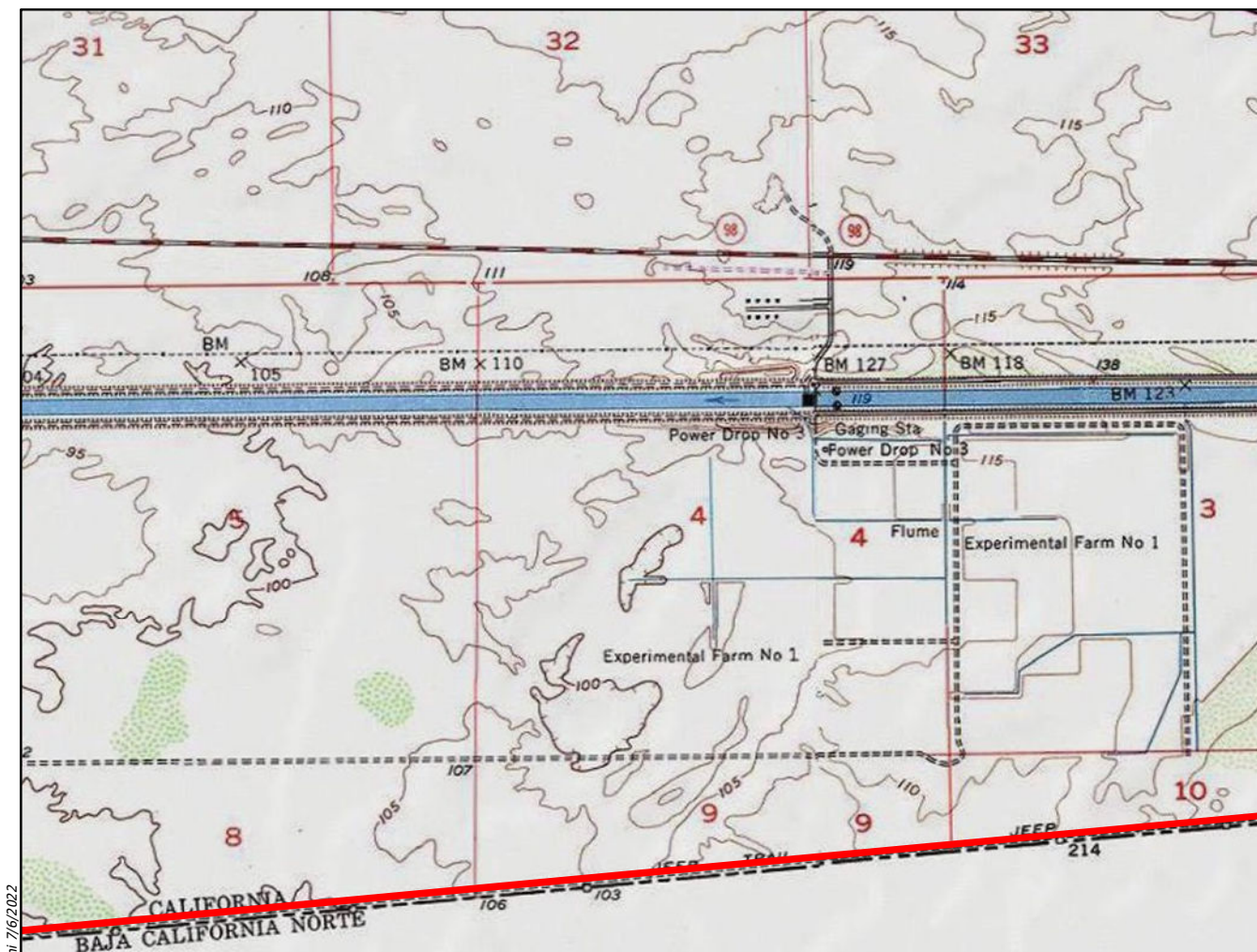
0 1,000 2,000

Midway Well NW, CA (1979)
CA 7.5-minute Topographic Quadrangle
US Geological Survey



Map Date: 7/6/2022
Service Layer Credits: Copyright © 2013 National Geographic Society, i-cubed

**Figure 1. Project Location and Vicinity
Sheet 4 of 9**



Location: N:\2020\2020-142_Cedar_1_Solar\WAPS\Location_Vicinity\Vega_4_Access_LNV_Quad_V2.mxd (TR) troteilini 7/6/2022

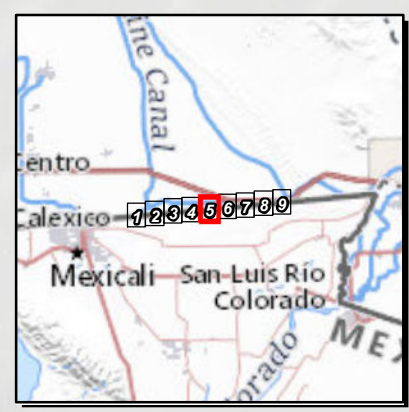
- Vega 4 Project Area - 440.802 ac.
- Access Road - 60.735 ac.

S.8, 9, 10 T.17S R.18E SBBM

Imperial County, California
 Latitude (NAD83): 32.680149 °
 Longitude (NAD83): -115.301601 °
 Watershed: Salton Sea (#18100204)

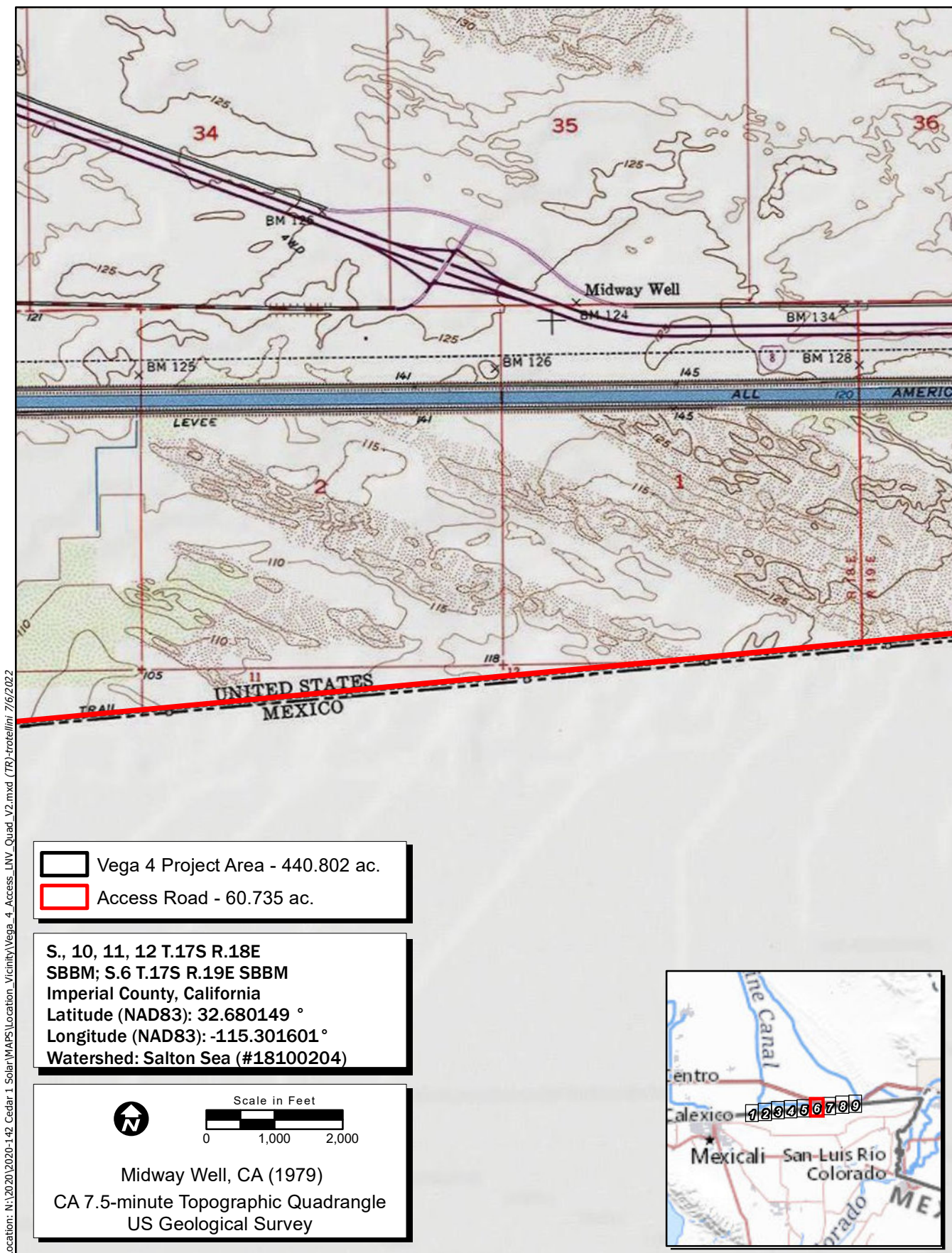
Scale in Feet

Midway Well NW, CA (1979)
 Midway Well, CA (1979)
 CA 7.5-minute Topographic Quadrangle
 US Geological Survey



Map Date: 7/6/2022
 Service Layer Credits: Copyright © 2013 National Geographic Society, i-cubed

Figure 1. Project Location and Vicinity
Sheet 5 of 9



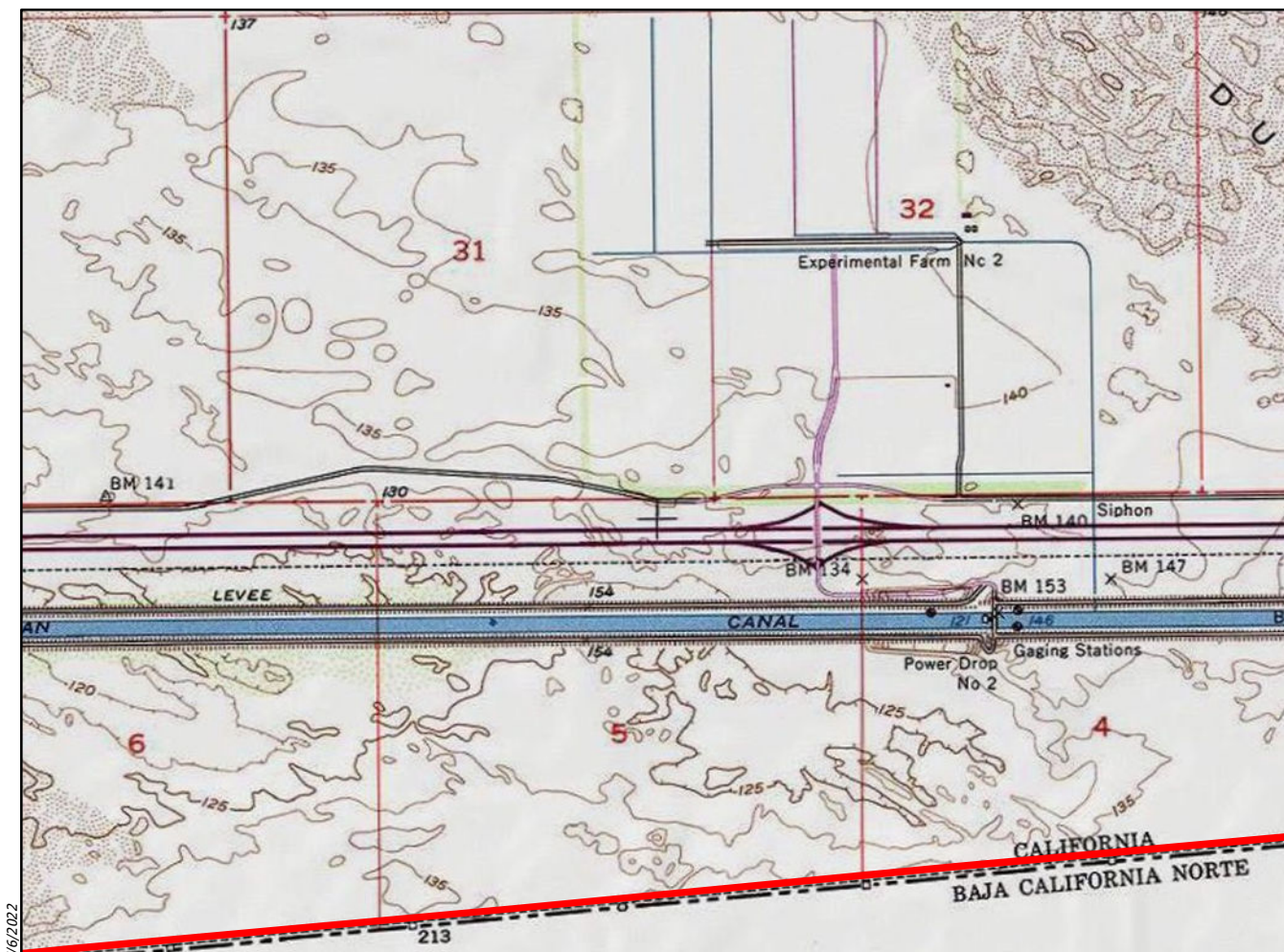
Location: N:\2020\2020-142_Cedar_1_Solar\WAPS\Location_Vicinity\Vega_4_Access_LNV_Quad_V2.mxd (TR):tracellini 7/6/2022

Map Date: 7/6/2022

Service Layer Credits: Copyright © 2013 National Geographic Society, i-cubed

Figure 1. Project Location and Vicinity
Sheet 6 of 9

2020-142 Vega SES 4



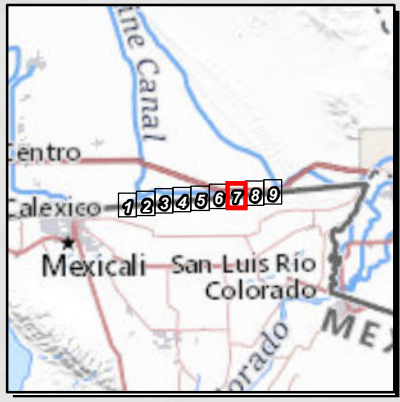
Location: N:\2020\2020-142_Cedar_1_Solar\WAPS\Location_Vicinity\Vega_4_Access_LNV_Quad_V2.mxd (TR)-tracellini 7/6/2022

- Vega 4 Project Area - 440.802 ac.
- Access Road - 60.735 ac.

S.4, 5, 6 T.17S R.19E SBBM
 Imperial County, California
 Latitude (NAD83): 32.680149 °
 Longitude (NAD83): -115.301601 °
 Watershed: Salton Sea (#18100204)

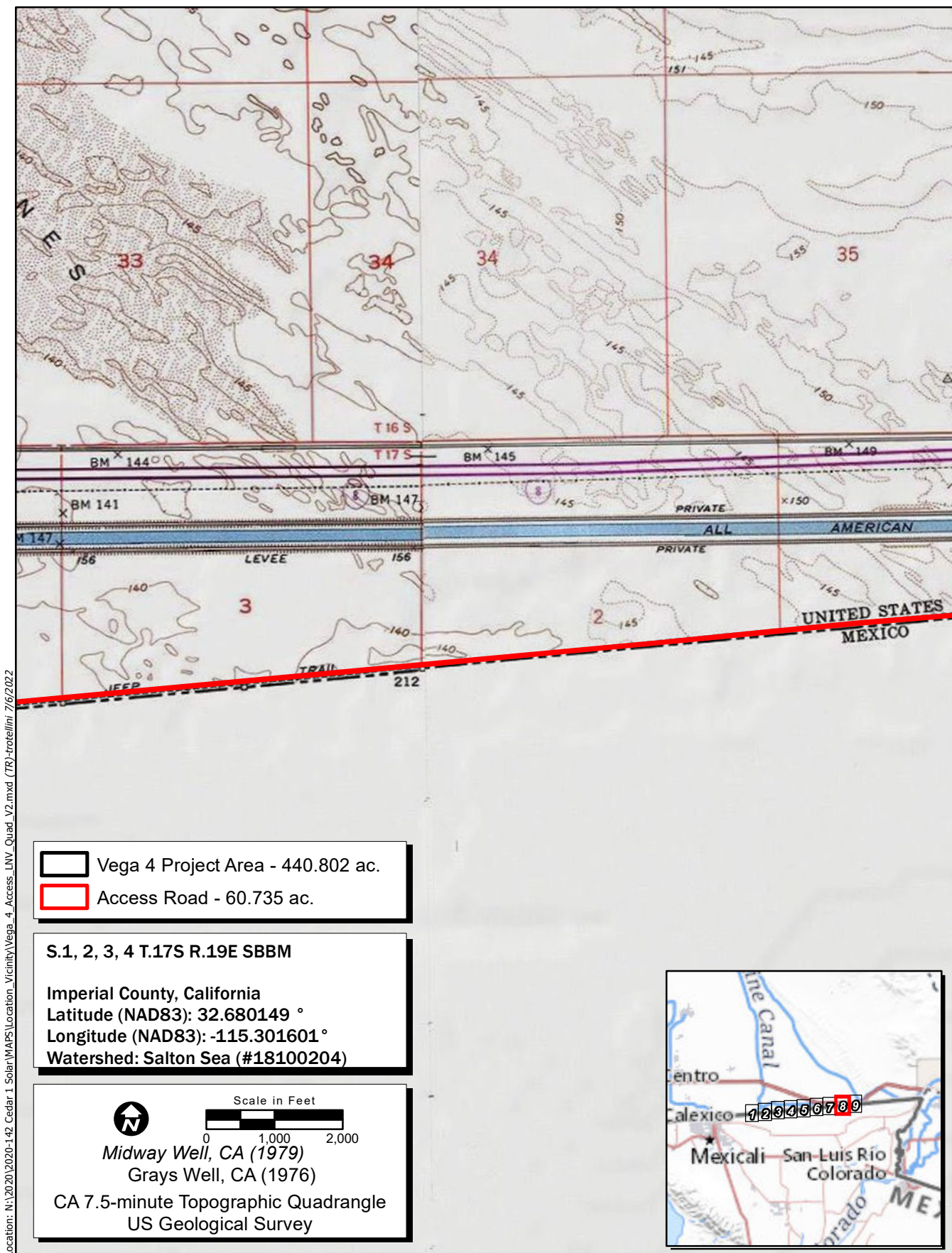
Scale in Feet

Midway Well, CA (1979)
 CA 7.5-minute Topographic Quadrangle
 US Geological Survey



Map Date: 7/6/2022
 Service Layer Credits: Copyright © 2013 National Geographic Society, i-cubed

Figure 1. Project Location and Vicinity
Sheet 7 of 9



Location: N:\2020\2020-142_Cedar_1_Solar\WAPS\Location_Vicinity\Vega_4_Access_LNV_Quad_V2.mxd (TR) trocillini 7/6/2022

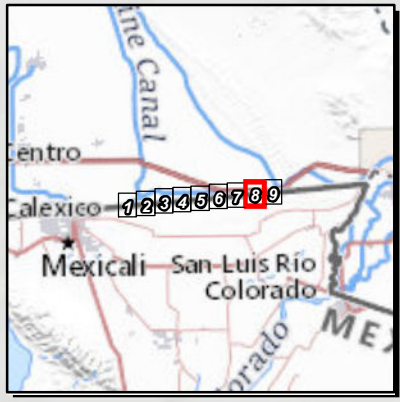
- Vega 4 Project Area - 440.802 ac.
- Access Road - 60.735 ac.

S.1, 2, 3, 4 T.17S R.19E SBBM

Imperial County, California
 Latitude (NAD83): 32.680149 °
 Longitude (NAD83): -115.301601 °
 Watershed: Salton Sea (#18100204)

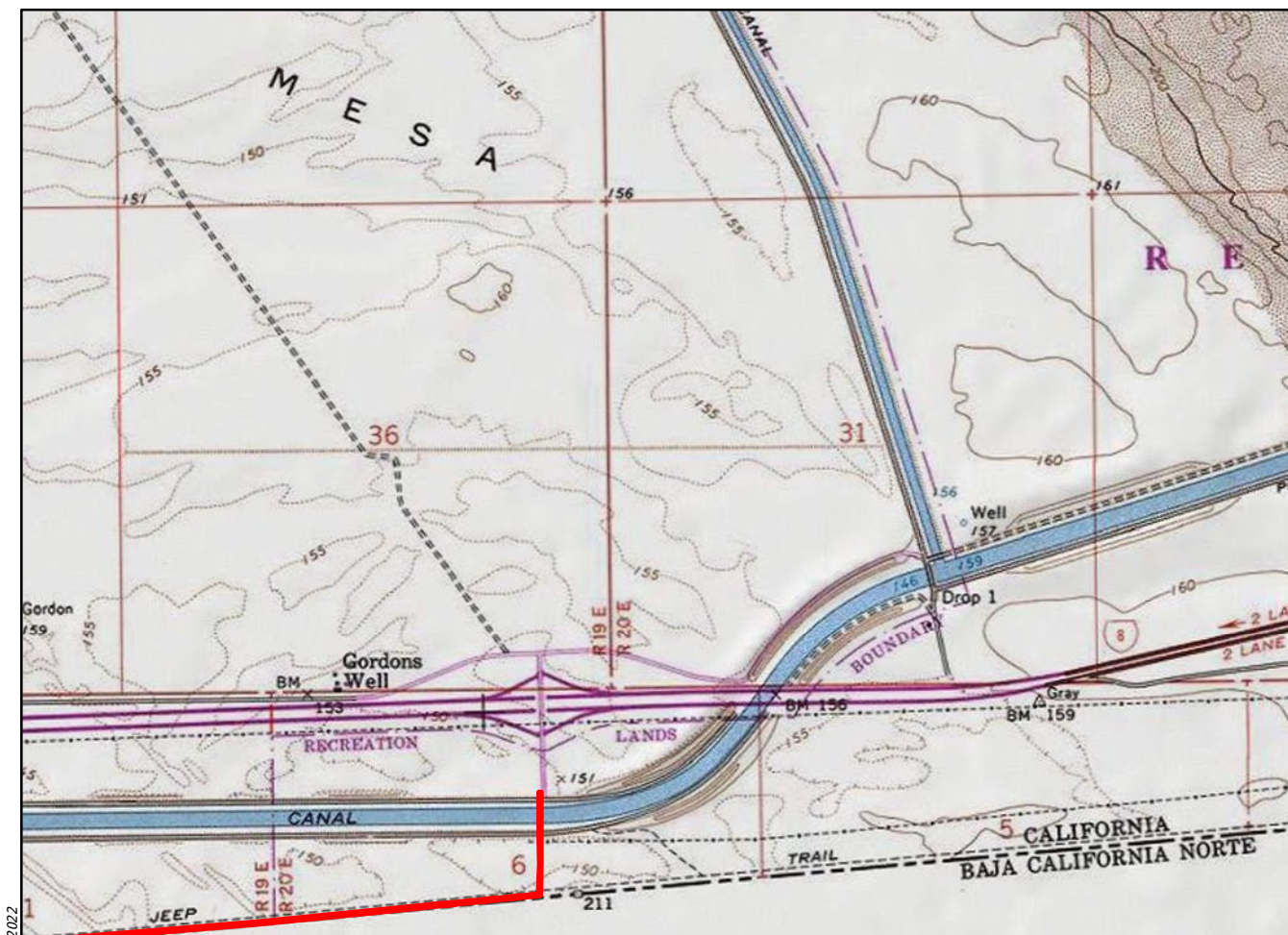
Scale in Feet

Midway Well, CA (1979)
 Grays Well, CA (1976)
 CA 7.5-minute Topographic Quadrangle
 US Geological Survey



Map Date: 7/6/2022
 Service Layer Credits: Copyright © 2013 National Geographic Society, i-cubed


Figure 1. Project Location and Vicinity
Sheet 8 of 9



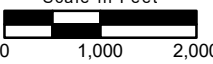
Location: N:\2020\2020-142_Cedar_1_Solar\WAPS\Location_Vicinity\Vega_4_Access_LNV_Quad_V2.mxd (TR) trocchini 7/6/2022

- Vega 4 Project Area - 440.802 ac.
- Access Road - 60.735 ac.

**S.1 T.17S R.19E SBBM; S.6
T.17S R.20E SBBM**
Imperial County, California
Latitude (NAD83): 32.680149 °
Longitude (NAD83): -115.301601 °
Watershed: Salton Sea (#18100204)

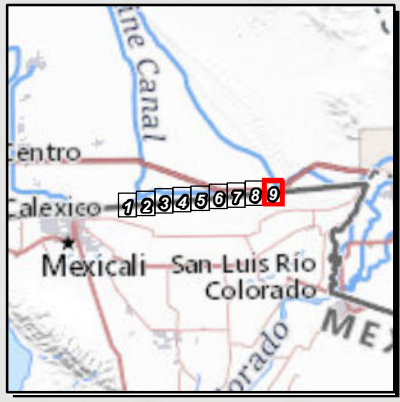


Scale in Feet



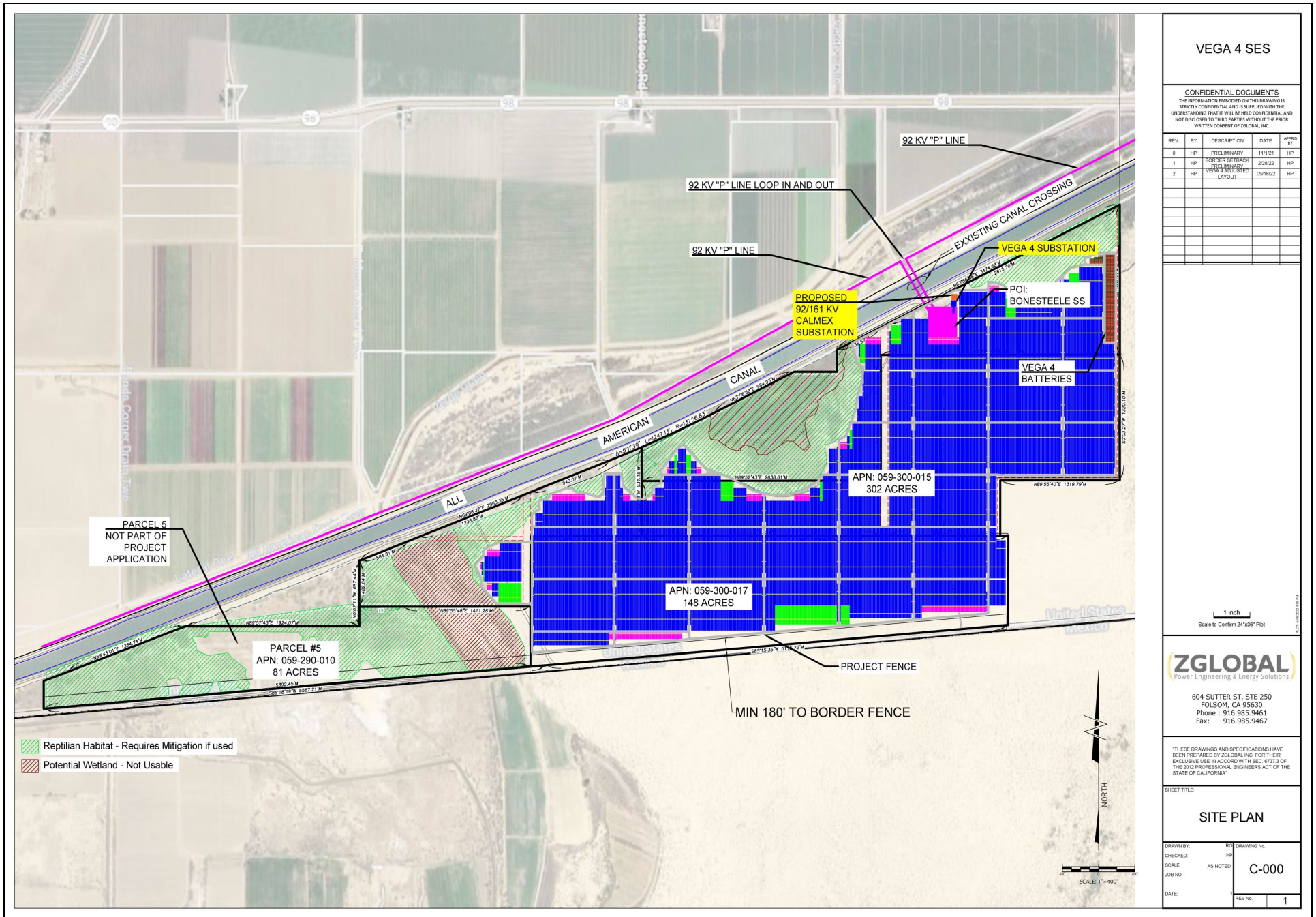
0 1,000 2,000

Grays Well, CA (1976)
CA 7.5-minute Topographic Quadrangle
US Geological Survey



Map Date: 7/6/2022
Service Layer Credits: Copyright © 2013 National Geographic Society, i-cubed

Figure 1. Project Location and Vicinity
Sheet 9 of 9



VEGA 4 SES

CONFIDENTIAL DOCUMENTS
 THE INFORMATION SHOWN ON THIS DRAWING IS STRICTLY CONFIDENTIAL AND IS SUPPLIED WITH THE UNDERSTANDING THAT IT WILL BE HELD CONFIDENTIAL AND NOT DISCLOSED TO THIRD PARTIES WITHOUT THE PRIOR WRITTEN CONSENT OF ZGLOBAL, INC.

REV.	BY	DESCRIPTION	DATE	APPROV BY
0	HP	PRELIMINARY	11/1/21	HP
1	HP	BORDER SETBACK PRELIMINARY	2/28/22	HP
2	HP	VEGA 4 ADJUSTED LAYOUT	05/18/22	HP

1 inch
 Scale to Confirm 24"x36" Print

ZGLOBAL
 Power Engineering & Energy Solutions

604 SUTTER ST, STE 250
 FOLSOM, CA 95630
 Phone : 916.985.9461
 Fax : 916.985.9467

THESE DRAWINGS AND SPECIFICATIONS HAVE BEEN PREPARED BY ZGLOBAL, INC. FOR THEIR EXCLUSIVE USE IN ACCORD WITH SEC. 8737.3 OF THE STATE PROFESSIONAL ENGINEERS ACT OF THE STATE OF CALIFORNIA

SHEET TITLE

SITE PLAN

DRAWN BY:	RO	DRAWING No:	
CHECKED:	HP		
SCALE:	AS NOTED	C-000	
JOB NO:			
DATE:			
		REV No:	1

2.0 REGULATORY SETTING

2.1 Waters of the United States

This report describes aquatic resources, including wetlands, that may be regulated by the USACE under Section 404 of the federal CWA. Waters of the U.S. includes both wetlands and other waters, as described below.

2.1.1 Wetlands

Wetlands are defined as “those areas that are inundated or saturated by surface or groundwater at a frequency and duration sufficient to support, and that under normal circumstances do support, a prevalence of vegetation typically adapted for life in saturated soil conditions” (51 Federal Register [FR] 41250, Nov. 13, 1986, as amended at 58 FR 45036, Aug. 25, 1993). Wetlands can be perennial or intermittent.

2.1.2 Other Waters

Other waters that may be found in the Study Area are non-tidal, perennial, and intermittent watercourses and tributaries to such watercourses [51 FR 41250, Nov. 13, 1986, as amended at 58 FR 45036, Aug. 25, 1993]. The limit of USACE jurisdiction for non-tidal watercourses (without adjacent wetlands) is defined in 33 Code of Federal Regulations [CFR] 328.4(c)(1) as the “ordinary high water mark” (OHWM). The OHWM is defined as the “line on the shore established by the fluctuations of water and indicated by physical characteristics such as clear, natural line impressed on the bank, shelving, changes in the character of soil, destruction of terrestrial vegetation, the presence of litter and debris, or other appropriate means that consider the characteristics of the surrounding areas” approximation of the lateral limit of USACE jurisdiction. The upstream limits of other waters are defined as the point where the OHWM is no longer perceptible.

2.2 Clean Water Act

The USACE regulates discharge of dredged or fill material into waters of the U.S. under Section 404 of the CWA. *Discharges of fill material* is defined as the addition of fill material into waters of the U.S., including, but not limited to the following: placement of fill necessary for the construction of any structure, or impoundment requiring rock, sand, dirt, or other material for its construction; site development fills for recreational, industrial, commercial, residential, and other uses; causeways or road fills; and fill for intake and outfall pipes, and subaqueous utility lines [33 Code of Federal Regulations (CFR) § 328.2(f)]. In addition, Section 401 of the CWA (33 U.S. Code [USC] 1341) is regulated by the Regional Water Quality Control Board (RWQCB) and requires any applicant for a federal license or permit to conduct any activity that may result in a discharge of a pollutant into waters of the U.S. to obtain a certification that the discharge will comply with the applicable effluent limitations and water quality standards. Section 401 Certification, “gives states and authorized tribes the authority to grant or waive certification of proposed federal licenses or permits that may discharge into waters of the US” (33 USC 1251).

On April 21, 2020, the U.S. Environmental Protection Agency (USEPA) and the Department of the Army (Army) published the NWPR to define waters of the United States in the *Federal Register*. This rule became effective on June 22, 2020.

In August 2021, a judge in the U.S. District Court for the District of Arizona ruled to vacate the NWPR. On October 1, 2021, Judge Márquez of the U.S. District Court for the District of Arizona granted the United States Environmental Protection Agency (EPA) and United States Department of the Army, Corps of Engineers (Corps) an extension until November 30, 2021 to make proposals for further proceedings concerning challenges to the 2020 regulatory definition of the “Waters of the United States” (WOTUS) and Navigable Waters Protection Rule (NWPR). On December 7, 2021 the EPA and USACE announced a proposed rule to revise the definition of “waters of the United States.” This proposal would return to the pre-2015 definitions of waters of the U.S. The proposed rule was open for public comment until February 7, 2022. The final rule has not yet been issued.

In the USACE/USEPA CWA regulations (33 CFR 328.3[a]), the term “waters of the U.S.” is defined as follows:

1. All waters which are currently used, or were used in the past, or may be susceptible to use in interstate or foreign commerce, including all waters which are subject to the ebb and flow of the tide;
2. All interstate waters including interstate wetlands;
3. All other waters such as intrastate lakes, rivers, streams (including intermittent streams), mudflats, sandflats, wetlands, sloughs, prairie potholes, wet meadows, playa lakes, or natural ponds, the use, degradation or destruction of which could affect interstate or foreign commerce including any such waters: (i) Which are or could be used by interstate or foreign travelers for recreational or other purposes; or (ii) From which fish or shellfish are or could be taken and sold in interstate or foreign commerce; or (iii) Which are used or could be used for industrial purpose by industries in interstate commerce;
4. All impoundments of waters otherwise defined as waters of the U.S. under the definition;
5. Tributaries of waters identified in paragraphs (a)(1)-(4) of this section;
6. The territorial seas;
7. Wetlands adjacent to waters (other than waters that are themselves wetlands) identified in 1-6 above

2.3 Porter-Cologne Water Quality Act

The Porter-Cologne Water Quality Control Act requires “any person discharging waste, or proposing to discharge waste, within any region that could affect the waters of the State to file a report of discharge” with the RWQCB through State Wetland Definition and Procedures for Discharges of Dredged or Fill Material to Waters of the State (Procedures) (California Code of Regulations [CCR], title 23, § 3855) (State Water Resources Control Board [SWRCB] 2021). *Waters of the State* is defined as any surface water or groundwater, including saline waters, within the boundaries of the State (California Water Code § 13050[e]). Pollution is defined as an alteration of the quality of the waters of the state by waste to a degree that unreasonably affects its beneficial uses (California Water Code § 13050) and includes filling in

waters of the State. Note that CCR, title 23, § 3855 applies only to individual water quality certifications, but the new Procedures extend the application of § 3855 to individual waste discharge requirements for discharges of dredged or fill material to Waters of the State and waivers thereof.

A permit for impacts to Waters of the State would likely be required under the CWA and/or Porter-Cologne Water Quality Control Act. To determine whether a project should be regulated pursuant to the Porter-Cologne Water Quality Control Act, the RWQCB considers whether project activities could impact the quality of Waters of the State.

2.4 California Fish and Game Code Section 1602

Pursuant to Section 1602 of the California Fish and Game Code, a Streambed Alteration Agreement (SAA) application must be submitted for “any activity that may substantially divert or obstruct the natural flow or substantially change the bed, channel, or bank of any river, stream, or lake” (CDFW 2021). In Title 14 of the CCR, Section 1.72, the CDFW defines a *stream* (including creeks and rivers) as “a body of water that flows at least periodically or intermittently through a bed or channel having banks and supports fish or other aquatic life. This includes watercourses having a surface or subsurface flow that supports or has supported riparian vegetation.”

The CDFW’s jurisdiction includes drainages with a definable bed, bank, or channel with the jurisdictional limit being the top of bank (TOB). It also includes areas that support intermittent, perennial, or subsurface flows; supports fish or other aquatic life; or supports riparian or hydrophytic vegetation. It also includes areas that have a hydrologic source.

The CDFW will determine if the proposed actions will result in diversion, obstruction, or change of the natural flow, bed, channel, or bank of any river, stream, or lake that supports fish or wildlife. The CDFW will submit a SAA that includes measures to protect affected fish and wildlife resources; this SAA is the final proposal agreed upon by the CDFW and the applicant.

Table 2. Summary of Federal, State, and Local Regulations		
Federal Regulations		
Regulation	Resource	Regulating Agencies
Federal Clean Water Act	Aquatic features meeting the definition of Waters of the US	USACE, RWQCB
State Regulations		
Regulation	Resource	Regulating Agency
California Fish and Game Code Section 1602	River, stream, or lake and associated riparian habitat	CDFW
Local Regulations		
Regulation	Resource	Regulating Agency
Porter-Cologne Water Quality Act	Aquatic features meeting the definition of Waters of the State	RWQCB

3.0 METHODS

3.1 Pre-Survey Investigations

Due to the size of the area and limited road access, an initial survey utilizing a small, unmanned aircraft system (sUAS) was conducted to assess current site conditions and gather high-resolution imagery. Photos collected during the sUAS survey were then combined into a single orthomosaic image that was incorporated into mapping files in a Geographic Information System (GIS). The information gathered from the sUAS/drone survey were then used to assist delineation specialists with accurate mapping of potential aquatic resources onsite. Prior to conducting the field delineations, the following resources were reviewed to identify potentially jurisdictional areas: sUAS imagery, satellite aerial imagery (Google Earth 2018, ESRI 2022), the National Wetlands Database, the online web soil survey (Natural Resources Conservation Service [NRCS] 2022a), and hydric soils list for the area.

3.2 Field Survey Investigation

This aquatic resources delineation was conducted in accordance with the *Corps of Engineers Wetlands Delineation Manual* (Environmental Laboratory 1987), the *Regional Supplement to the Corps of Engineers Wetland Delineation Manual: Arid West Region* (USACE 2008a), *A Field Guide to the Identification of the Ordinary High Water Mark (OHWM) in the Arid West Region of the Western United States* (USACE 2008b), and the *Updated Datasheet for the Identification of the Ordinary High Water Mark (OHWM) in the Arid West Region of the Western United States* (USACE 2010). The boundaries of aquatic resources were delineated through standard field methods (e.g., paired sample set analyses) and aerial photograph interpretation. Field data was recorded on Wetland Determination Data Forms - Arid West Region and Arid West OHWM Datasheets (Attachment B). ESRI® and sUAS aerial imagery were used to assist with mapping and ground-truthing. *Munsell Soil Color Charts* (Kollmorgen Instruments Co. 1990) and the Web Soil Survey (NRCS 2020a) were used to aid in identifying hydric soils in the field. The Jepson Manual, 2nd Edition (Baldwin et al. 2012) and the USACE National Wetland Plant List (USACE 2018) were used for plant nomenclature and identification.

Where jurisdictional features were present, the extent of potential Waters of the State and CDFW-regulated streambed and top-of-bank limits were determined using the OHWM in accordance with USACE requirements and guidelines, as well as RWQCB and CDFW delineation guidance. Streambed widths were based on evidence of OHWM as observed during the field survey. In addition, each of the drainages were evaluated for the presence or absence of sediment deposits, litter/debris, water stains, soil shelving, and/or exposed roots indicating active hydrology within the channel. Streambed widths and other lateral limits of jurisdiction were calculated and recorded. The extent of associated riparian habitat was based on the extent of the canopy of the riparian community within or directly adjacent to the feature. Bank-to-bank width measures were also recorded and used as a measure of CDFW jurisdictional boundary where features lacked riparian vegetation. Feature characteristics and measurements were recorded directly into the data dictionary in the GPS unit. Characteristics of the majority of mapped features were also documented in photographs.

Paired locations were sampled to evaluate whether the vegetation, hydrology, and soils data supported an aquatic resource determination. At each paired location, one point was located such that it was within the estimated aquatic resource area, and the other point was situated outside the limits of the estimated aquatic resource area. Additional non-paired locations were sampled to confirm boundaries. Aquatic resources within the Study Area were recorded in the field using a post-processing capable Global Positioning System (GPS) unit with sub-meter accuracy (e.g., Juniper Geode™). Feature characteristics and measurements were recorded directly into the data dictionary in the GPS unit. Characteristics of mapped features were also documented in photographs.

Four separate field surveys were conducted by ECORP delineation specialists in 2020; the first being a general field reconnaissance of the Study Area to identify areas supporting potential state and federal jurisdictional waters. The initial survey was conducted in conjunction with the biological reconnaissance survey on September 28, 2020, by Christina Congedo, Caroline Garcia, Greg Hampton, and Christina Torres. The subsequent field surveys and formal delineations were conducted to verify preliminary results observed in the September survey and to collect additional data and photographs. These surveys were conducted on November 4-5, 2020, by Christina Congedo, Jennifer Kendrick, and Christina Torres; an additional survey was conducted on November 12, 2020, by Christina Congedo, Caroline Garcia, and Christina Torres. The entire Study Area was visually surveyed to determine the location and extent of aquatic resources, and special attention was given to the features identified during the initial survey described above. On April 12-13, 2022, Christina Torres and Caroline Garcia revisited the Study Area to assess the access road and verify that conditions of the solar field parcels had not changed since the 2020 surveys.

3.3 Post-Processing

The data collected in the field utilized ArcGIS™ Collector on a device (smartphone or tablet) connected to a submeter external receiver. The submeter receiver applies differential correction instantaneously in the field using the Satellite Based Augmentation System. The data were then viewed and analyzed for verification, edited, and compiled in GIS format at the time of download. ArcGIS™ software was used to develop the geodatabase and the shapefiles depicted on the figures included in this report.

4.0 RESULTS

4.1 Existing Site Conditions

The Study Area is located within relatively flat to gently sloping terrain situated at an elevational range of approximately 11 meters (38 feet) to 48 meters (159 feet) above mean sea level in Imperial County, California. The average winter low temperature in the vicinity of the Study Area is 44.0) and the average summer high temperature is 105.1°F. Average annual precipitation for El Centro is approximately 2.90 inches, which falls as rain (National Oceanic and Atmospheric Administration [NOAA] 2022a). A summary of rainfall data is provided in Table 3 below.

Season	Station	Total Precipitation (Inches)	Average Precipitation per Event (Inches)
2018-2019 ¹	El Centro 2 SSW, CA US	2.72	0.544
2019-2020 ¹	El Centro 2 SSW, CA US	5.01	0.626
2020-2021 ¹	El Centro 2 SSW, CA US	0.880	0.440
2021-2022 ²	El Centro 2 SSW, CA US	0.470	0.157

¹ Rainfall Data from October 1- September 30 (NOAA 2022b)

² Rainfall Data from October 1 – April 11 (NOAA 2022b)

A typical year analysis of the Study Area via a single point method was conducted using the USACE Antecedent Precipitation Tool (APT, USACE 2021). The APT analysis determines whether precipitation, drought, and other climatic conditions from the previous three months are *wet*, *normal*, or *dry* for the geographic area based on a rolling 30-year period (USEPA 2022). The APT was run for the dates the wetland delineation data were collected between September 28, 2020, November 4-5, 2020, and November 12, 2020. The APT demonstrated the site conditions on these dates represent a time of year referenced as the dry season, that the general region and site were in a moderate to severe drought, and that site conditions were normal in climatic conditions. The APT was also run for the dates the wetland delineation data were collected between April 12-13, 2022. The APT demonstrated the site conditions on these dates represent a time of year referenced as the dry season, that the general region and site were in an extreme drought, and that site conditions were normal in climatic conditions.

4.1.1 Vegetation Communities

Vegetation within the Study Area is characteristic of creosote bush scrub, riparian scrub, and wetland habitats. The eastern portion of the solar field consists primarily of disturbed creosote – white bursage scrub and disturbed areas with bordering riparian scrub and wetland habitats to the northern edge and western section of the Project. The western portion of the solar field primarily consists of riparian scrub and wetland habitats. The access road and adjacent areas consist of a mosaic of creosote bush scrub, creosote bush – white bursage scrub, and tamarisk thickets. There are four types of vegetation communities occurring within the Project: arrow weed thickets (disturbed), creosote bush scrub, creosote bush scrub – white bursage scrub (disturbed), and tamarisk thickets. Three land use types also occur within the Project: disturbed, urban/developed, and urban/developed (roads). Four additional vegetation communities were observed within the buffer, but not within the Study Area, and include: creosote bush scrub – white bursage scrub, creosote bush scrub (disturbed), active agriculture, and fallow agriculture.

Arrow weed thickets are associated with moderate to dense scrub primarily dominated by arrow weed (*Pluchea sericea*). Other species that occur as scattered individuals included tamarisk (*Tamarix* spp.), willow baccharis (*Baccharis salicina*), and big saltbush (*Atriplex lentiformis*). Disturbed arrow weed thickets are arrow weed thickets that have been previously altered. On this Project, this vegetation cover is characterized as sparser. Other plant species observed included alkali goldenbush (*Isocoma acradenia*).

Creosote bush scrub is dominated by a nearly monotypic stand of creosote bush (*Larrea tridentata*) with an open canopy and an herbaceous layer of seasonal annuals and perennials. Other species that occurred on the Project included white bursage (*Ambrosia dumosa*), apricot mallow (*Sphaeralcea ambigua*), and fanleaf crinkle mat (*Tiquilia plicata*). Disturbed areas of this community were sparser with a higher density of nonnative herbs. Other plant species observed include ephedra (*Ephedra trifurca* and *Ephedra* sp.) and crinklemat.

Creosote bush – white bursage scrub consists of creosote bush and white bursage that are co-dominant in the shrub canopy with an absent to intermittent herbaceous layer of seasonal annuals. Along the access road, other plant species observed within this community include ephedra, alkali goldenbush, and scattered individuals of mesquite (*Prosopis* sp.). Within the planned solar field, this vegetation cover is disturbed and is characterized as sparser with a high percentage of nonnative plant species including common Mediterranean grass (*Schismus barbatus*) and Saharan mustard (*Brassica tournefortii*). Other plant species included dyebush (*Psoralea argemone*) and fanleaf crinkle mat.

Tamarisk thickets are characterized by a weedy monoculture of tamarisk. Within the Study Area, tamarisk and arrow weed were often co-dominant in this vegetation community. Other plant species observed included cattails (*Typha* spp.), screw bean mesquite (*Prosopis pubescens*), and willow baccharis.

Disturbed land includes areas where the native vegetation community has been heavily influenced by human actions, such as grading, trash dumping, and off-highway vehicle use, but lack development. On this Project, the areas consisted primarily of bare ground and Mediterranean grass. Other plant species observed on the Project included dyebush and white bursage.

Areas mapped as developed have been constructed upon or otherwise physically altered to an extent that natural vegetation communities are no longer supported. On the Study Area, this land cover was dominant and consisted primarily of compacted dirt roads, structures, and landscape trees including Mexican fan palm (*Washingtonia robusta*) and Mexican palo verde (*Parkinsonia aculeata*).

Active agriculture includes planted, typically monotypic, rows of crops of annual and perennial species with open space between rows. Species composition frequently changes by season and year. Active agriculture often occurs in upland areas with high soil quality, or floodplains and are almost always artificially irrigated. This land cover was observed in the eastern portion and southwest of the solar field and south of the access road.

Fallow agricultural lands include remnant signs of row crops with open space between rows. Agricultural lands often occur in upland areas with high soil quality, or floodplains, and are almost always artificially irrigated. This land cover was observed periodically to the south of the access road within the country of Mexico. Access to view these areas was obstructed by the U.S./Mexico border wall, but unvegetated row crops were observed from a distance.

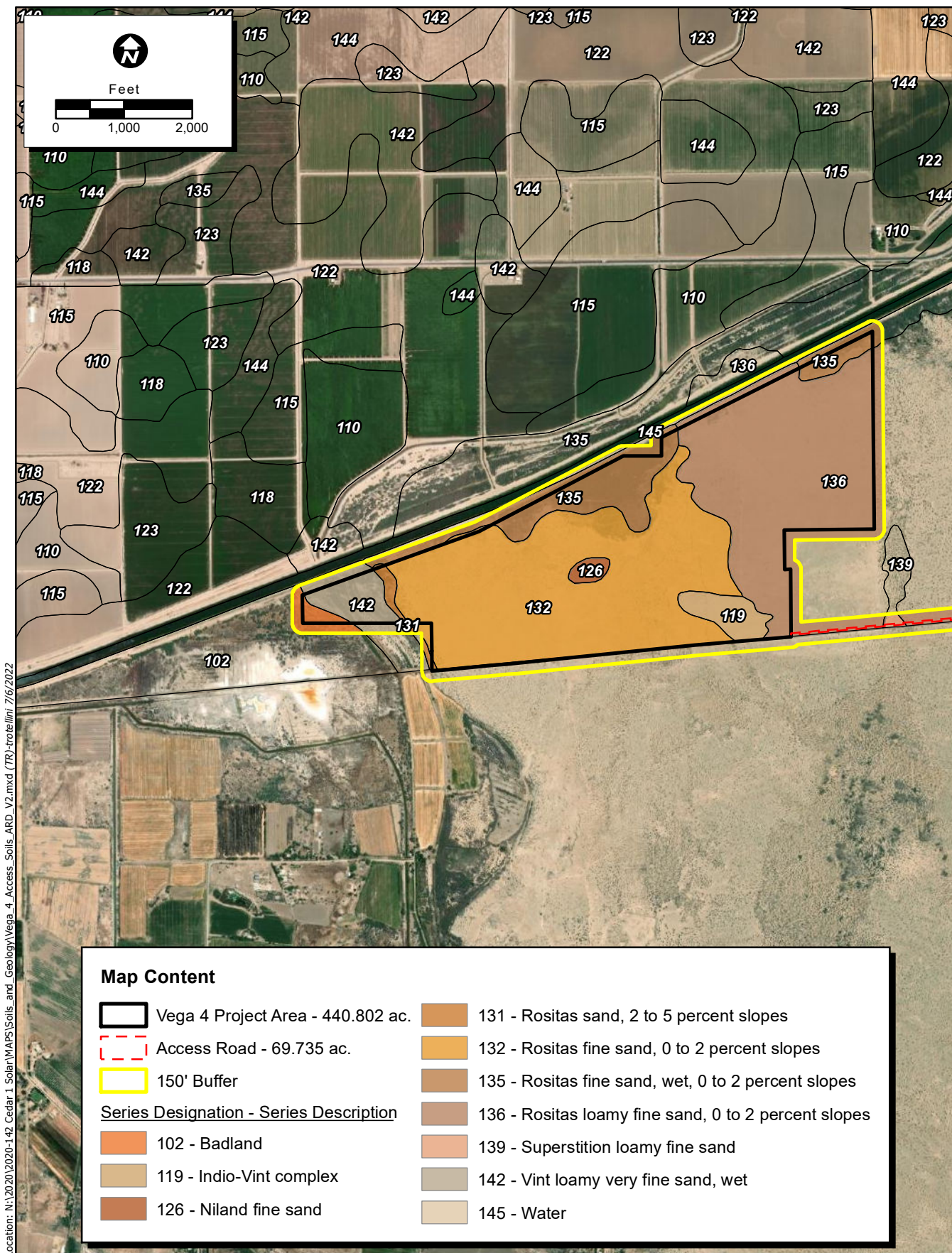
4.1.2 Soils

According to the Web Soil Survey (NRCS 2022a), twelve soil units, or types, have been mapped within the Study Area (Figure 3). Summary characteristics based on official series descriptions for each of the soil series mapped within the alignments are provided in Table 4 below (NRCS 2022a; 2022b; 2022c).

Table 4. Natural Resources Conservation Service Soil Types within the Study Area						
Map Unit Symbol	Map Unit Name	Taxonomic Class	Taxonomic Order	Drainage Class	Hydric Rating	Location
102	Badland	N/A	N/A	N/A	N/A	Solar Field
111	Holtville-Imperial silty clay loams	Clayey over loamy, montmorillonitic (calcareous), hyperthermic Typic Torrifluvents	Entisols	Well drained	No	Access Road
119	Indio-Vint complex	Coarse-silty, mixed (calcareous), hyperthermic Typic Torrifluvents	Entisols	Well drained	No	Solar Field
126	Niland fine sand	Sandy over clayey, mixed (calcareous), hyperthermic Typic Torrifluvents	Entisols	Moderately well drained	No	Solar Field
131	Rositas sand, 2 to 5 percent slopes	Mixed, hyperthermic Typic Torripsammments	Entisols	Somewhat excessively drained	No	Solar Field
132	Rositas fine sand, 0 to 2 percent slopes	Mixed, hyperthermic Typic Torripsammments	Entisols	Somewhat excessively drained	No	Solar Field, Access Road
133	Rositas fine sand, 2 to 9 percent slopes	Mixed, hyperthermic Typic Torripsammments	Entisols	Somewhat excessively drained	No	Access Road
135	Rositas fine sand, wet, 0 to 2 percent slopes	Mixed, hyperthermic Typic Torripsammments	Entisols	Moderately well drained	No	Solar Field, Access Road
136	Rositas loamy fine sand, 0 to 2 percent slopes	Mixed, hyperthermic Typic Torripsammments	Entisols	Somewhat excessively drained	No	Solar Field, Access Road
139	Superstition loamy fine sand	Sandy, mixed, hyperthermic Typic Calciorrhids	Aridisols	Somewhat excessively drained	No	Access Road
142	Vint loamy very fine sand, wet	Sandy, mixed, hyperthermic Typic Torrifluvents	Entisols	Moderately well drained	No	Solar Field
145	Water	N/A	N/A	N/A	N/A	Access Road

4.1.3 National Wetland Inventory

According to the National Wetlands Inventory (NWI, USFWS 2022a), there are two Palustrine features and two Riverine features mapped within the Study Area (Figure 4). All features correspond to aquatic features identified during the field study.



Location: N:\2020\2020-142_Cedar_1_Solar\WAPS\Soils_and_Geology\Vega_4_Access_Soils_ARL_V2.mxd (TR)-tristellini 7/6/2022

Map Date: 7/6/2022
 Service Layer Credits: Source: Esri, Maxar, Earthstar Geographics, and the GIS User Community

Figure 3. Natural Resources Conservation Service Soil Types - Sheet 1 of 9

2020-142 Vega SES 4



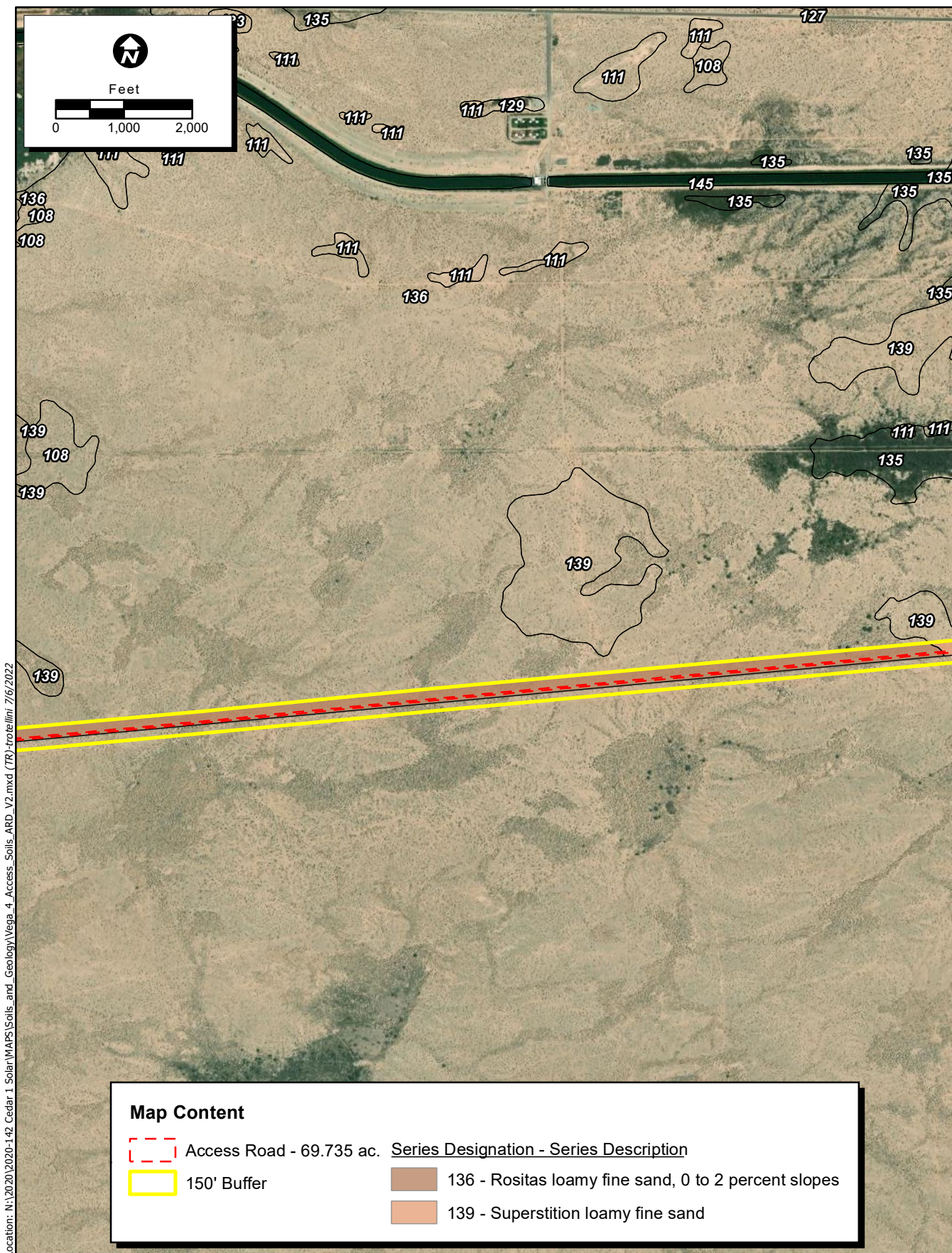
Location: N:\2020\2020-142_Cedar 1 Solar\MAPS\Soils_and_Geology\Vega_4_Access_Soils_ARD_V2.mxd (TR)-tristefani 7/6/2022

Map Content	
	Access Road - 69.735 ac. <u>Series Designation - Series Description</u>
	150' Buffer
	136 - Rositas loamy fine sand, 0 to 2 percent slopes
	139 - Superstition loamy fine sand





Map Date: 7/6/2022
 Service Layer Credits: Source: Esri, Maxar, Earthstar Geographics, and the GIS User Community

Figure 3. Natural Resources Conservation Service Soil Types - Sheet 2 of 9

2020-142 Vega SES 4



Location: N:\2020\2020-142_Cedar 1 Solar\WAPS\Soils_and_Geology\Vega_4_Access_Soils_ARL_V2.mxd (TR) - Project Date: 7/6/2022

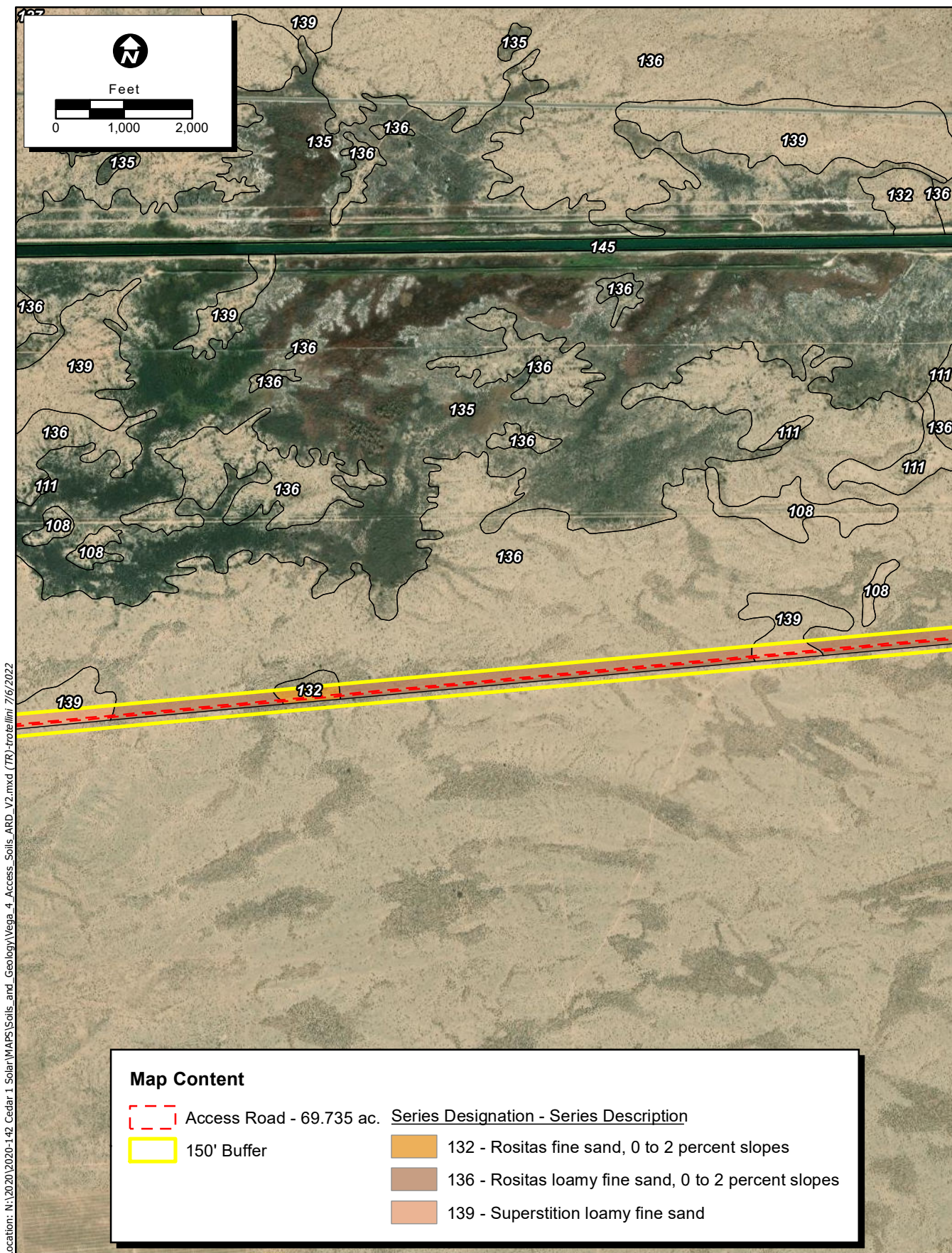
Map Content	
	Access Road - 69.735 ac. <u>Series Designation - Series Description</u>
	150' Buffer
	136 - Rositas loamy fine sand, 0 to 2 percent slopes
	139 - Superstition loamy fine sand

Map Date: 7/6/2022

Service Layer Credits: Source: Esri, Maxar, Earthstar Geographics, and the GIS User Community

Figure 3. Natural Resources Conservation Service Soil Types - Sheet 3 of 9

2020-142 Vega SES 4



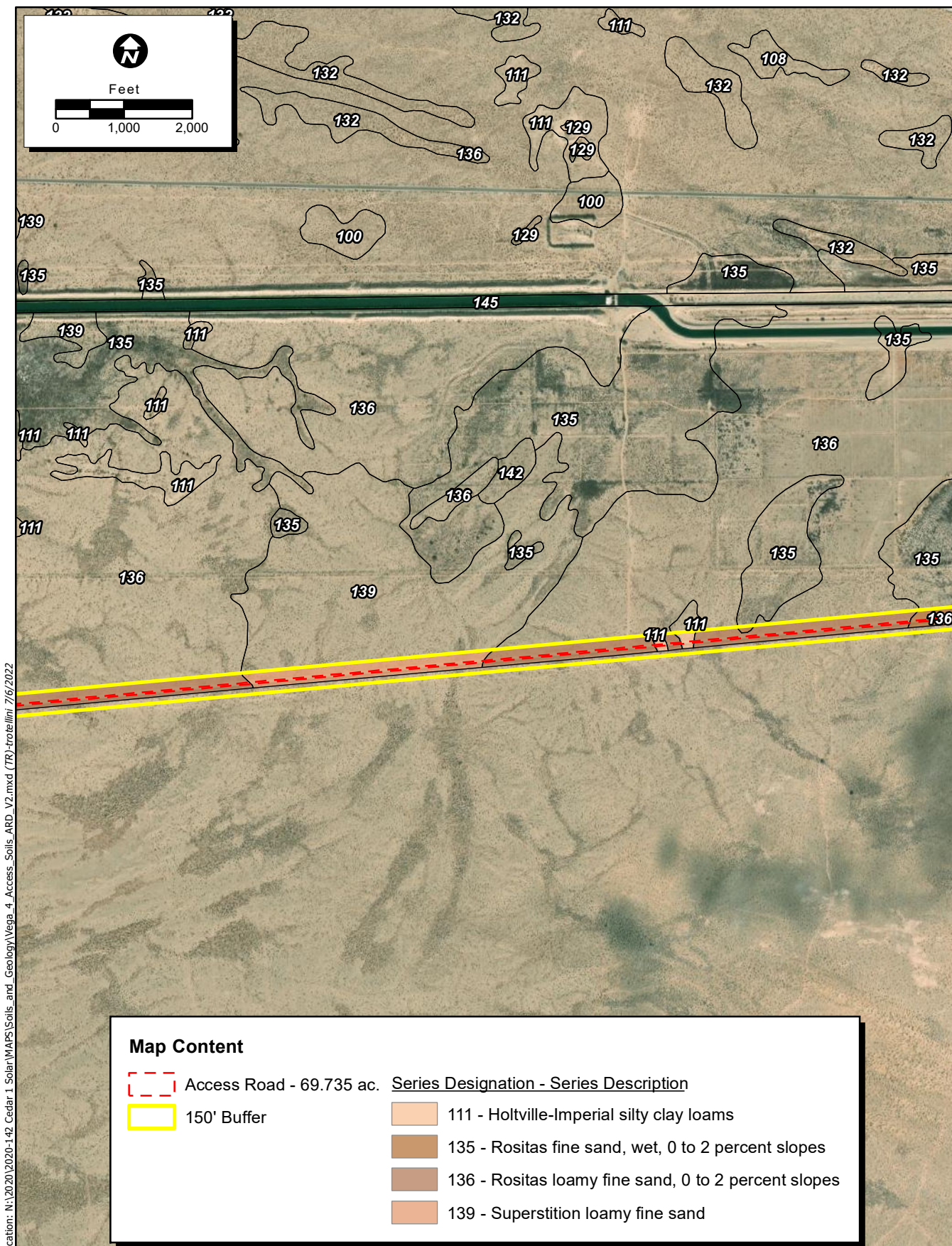
Location: N:\2020\2020-142_Cedar 1 Solar\WAPS\Soils_and_Geology\Vega_4_Access_Soils_ARD_V2.mxd (TR)-tristellini 7/6/2022

Map Date: 7/6/2022

Service Layer Credits: Source: Esri, Maxar, Earthstar Geographics, and the GIS User Community

Figure 3. Natural Resources Conservation Service Soil Types - Sheet 4 of 9

2020-142 Vega SES 4



Location: N:\2020\2020-142_Cedar 1 Solar\MAPS\Soils_and_Geology\Vega-4_Access_Soils_ARD_V2.mxd (TR)-tristefini_7/6/2022

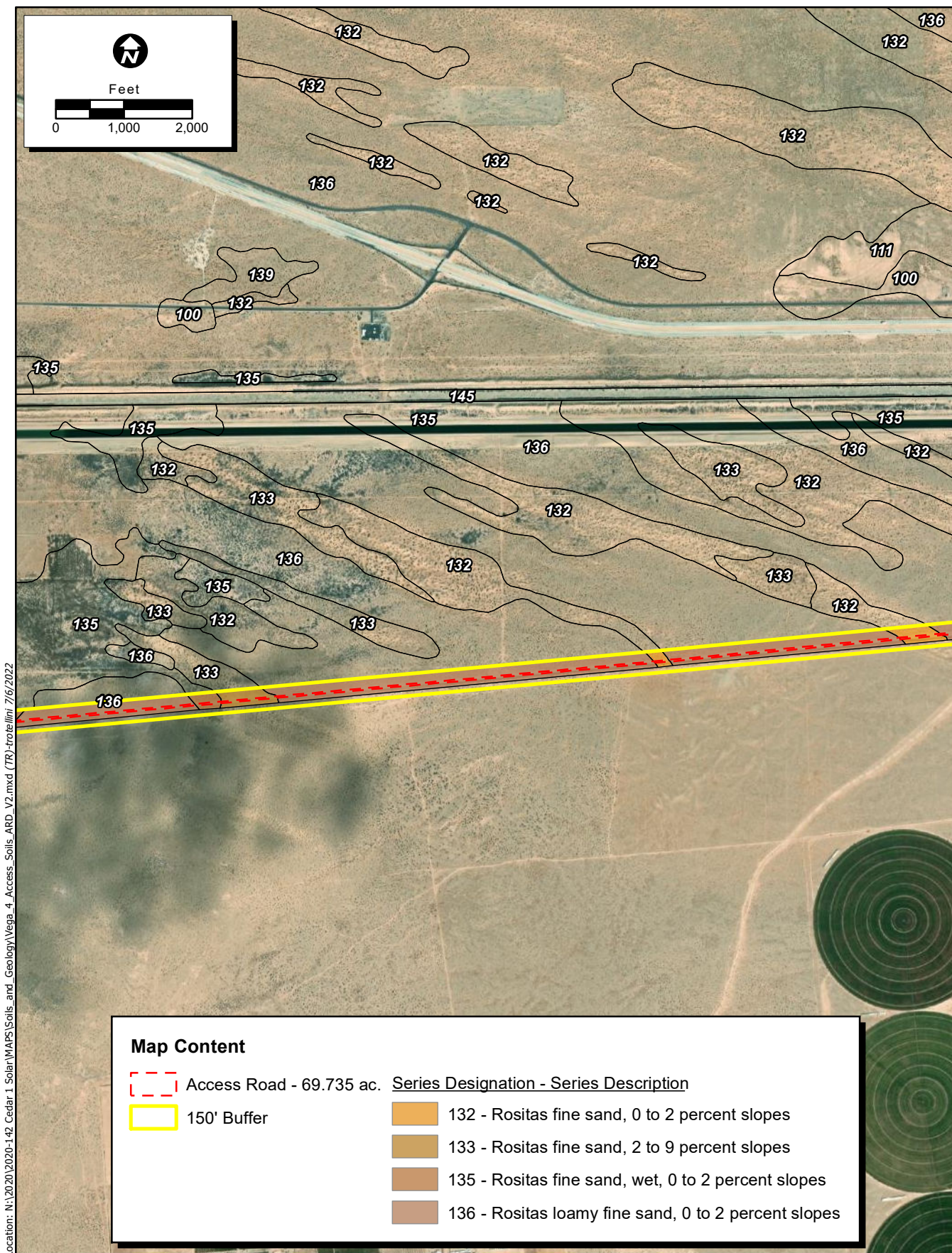
Map Content	
	Access Road - 69.735 ac.
	150' Buffer
Series Designation - Series Description	
	111 - Holtville-Imperial silty clay loams
	135 - Rositas fine sand, wet, 0 to 2 percent slopes
	136 - Rositas loamy fine sand, 0 to 2 percent slopes
	139 - Superstition loamy fine sand

Map Date: 7/6/2022

Service Layer Credits: Source: Esri, Maxar, Earthstar Geographics, and the GIS User Community

Figure 3. Natural Resources Conservation Service Soil Types - Sheet 5 of 9

2020-142 Vega SES 4



Location: N:\2020\2020-142_Cedar 1 Solar\WAPS\Soils_and_Geology\Vega_4_Access_Soils_ARD_V2.mxd (TR)-tristefini 7/6/2022

Map Content		Series Designation - Series Description	
	Access Road - 69.735 ac.		132 - Rositas fine sand, 0 to 2 percent slopes
	150' Buffer		133 - Rositas fine sand, 2 to 9 percent slopes
			135 - Rositas fine sand, wet, 0 to 2 percent slopes
			136 - Rositas loamy fine sand, 0 to 2 percent slopes

Map Date: 7/6/2022
 Service Layer Credits: Source: Esri, Maxar, Earthstar Geographics, and the GIS User Community





Figure 3. Natural Resources Conservation Service Soil Types - Sheet 6 of 9

2020-142 Vega SES 4



Location: N:\2020\2020-142_Cedar_1_Solar\MAPS\Soils_and_Geology\Vega_4_Access_Soils_ARL_V2.mxd (TR)-tristefani_7/6/2022

Map Content

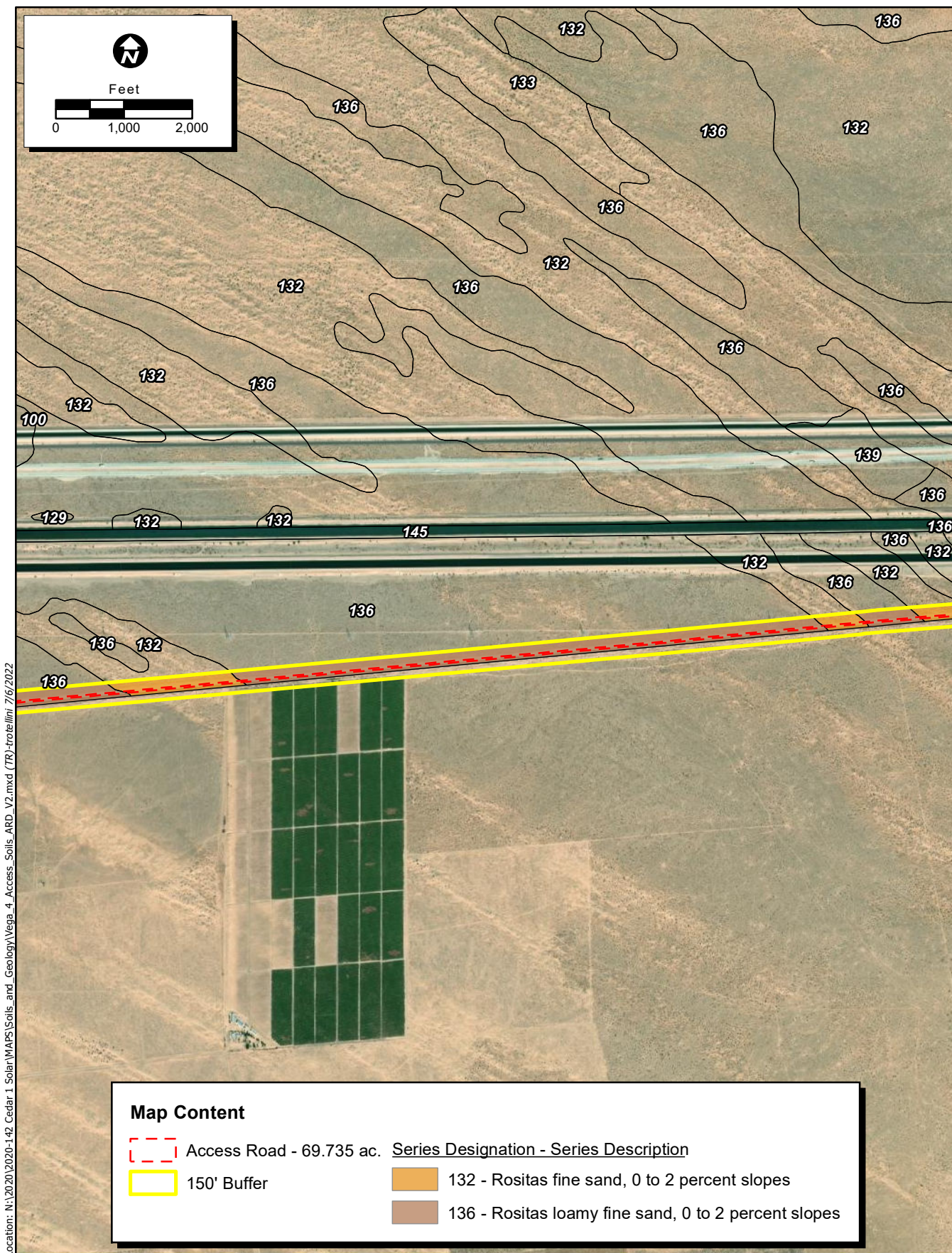
	Access Road - 69.735 ac.	<u>Series Designation - Series Description</u>
	150' Buffer	 132 - Rositas fine sand, 0 to 2 percent slopes
		 136 - Rositas loamy fine sand, 0 to 2 percent slopes

Map Date: 7/6/2022





Service Layer Credits: Source: Esri, Maxar, Earthstar Geographics, and the GIS User Community

Figure 3. Natural Resources Conservation Service Soil Types - Sheet 7 of 9

2020-142 Vega SES 4



Location: N:\2020\2020-142_Cedar 1 Solar\WAPS\Soils_and_Geology\Vega_4_Access_Soils_ARD_V2.mxd (TR)-tristefani 7/6/2022

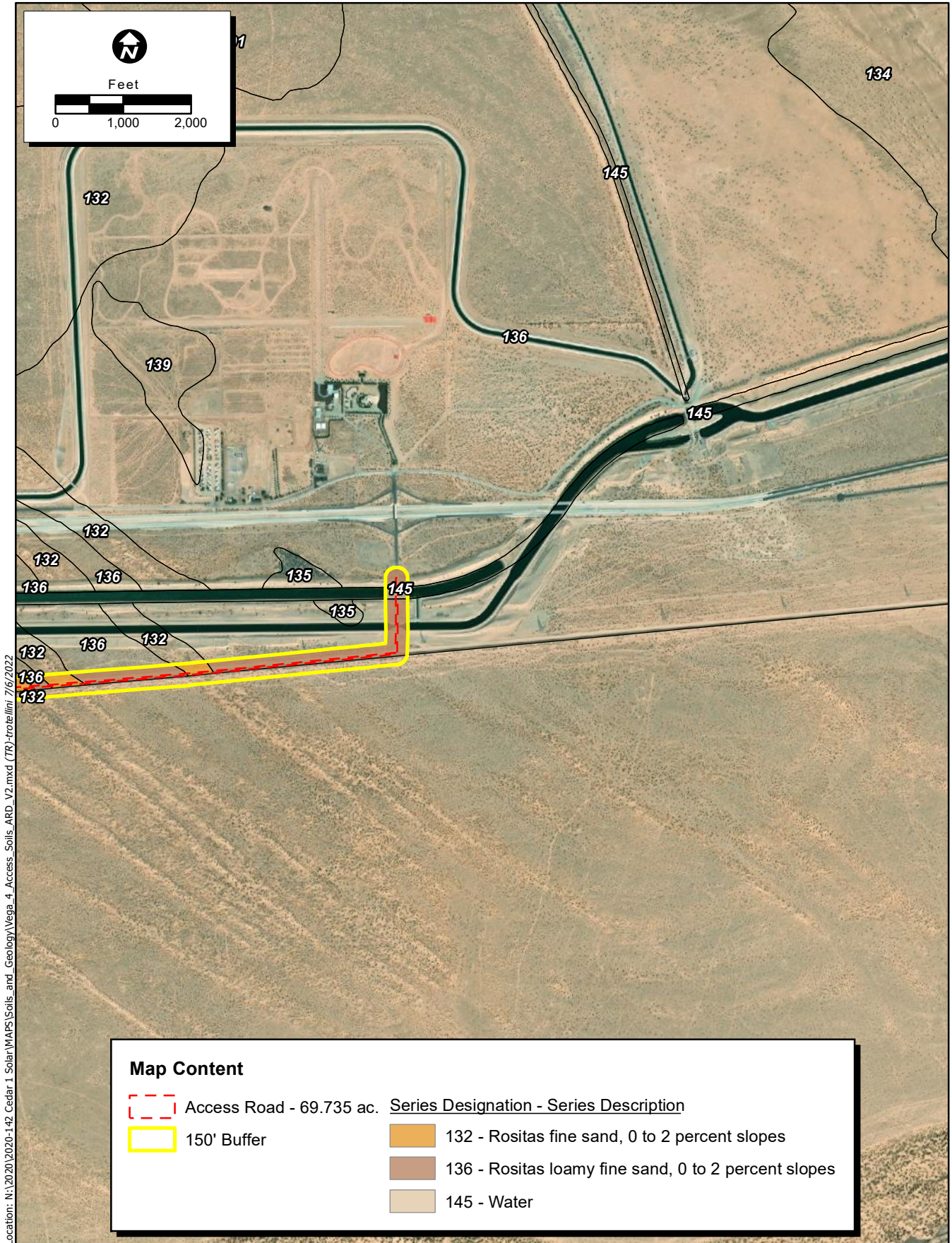
Map Content	
	Access Road - 69.735 ac. <u>Series Designation - Series Description</u>
	150' Buffer
	132 - Rositas fine sand, 0 to 2 percent slopes
	136 - Rositas loamy fine sand, 0 to 2 percent slopes

Map Date: 7/6/2022

Service Layer Credits: Source: Esri, Maxar, Earthstar Geographics, and the GIS User Community

Figure 3. Natural Resources Conservation Service Soil Types - Sheet 8 of 9

2020-142 Vega SES 4



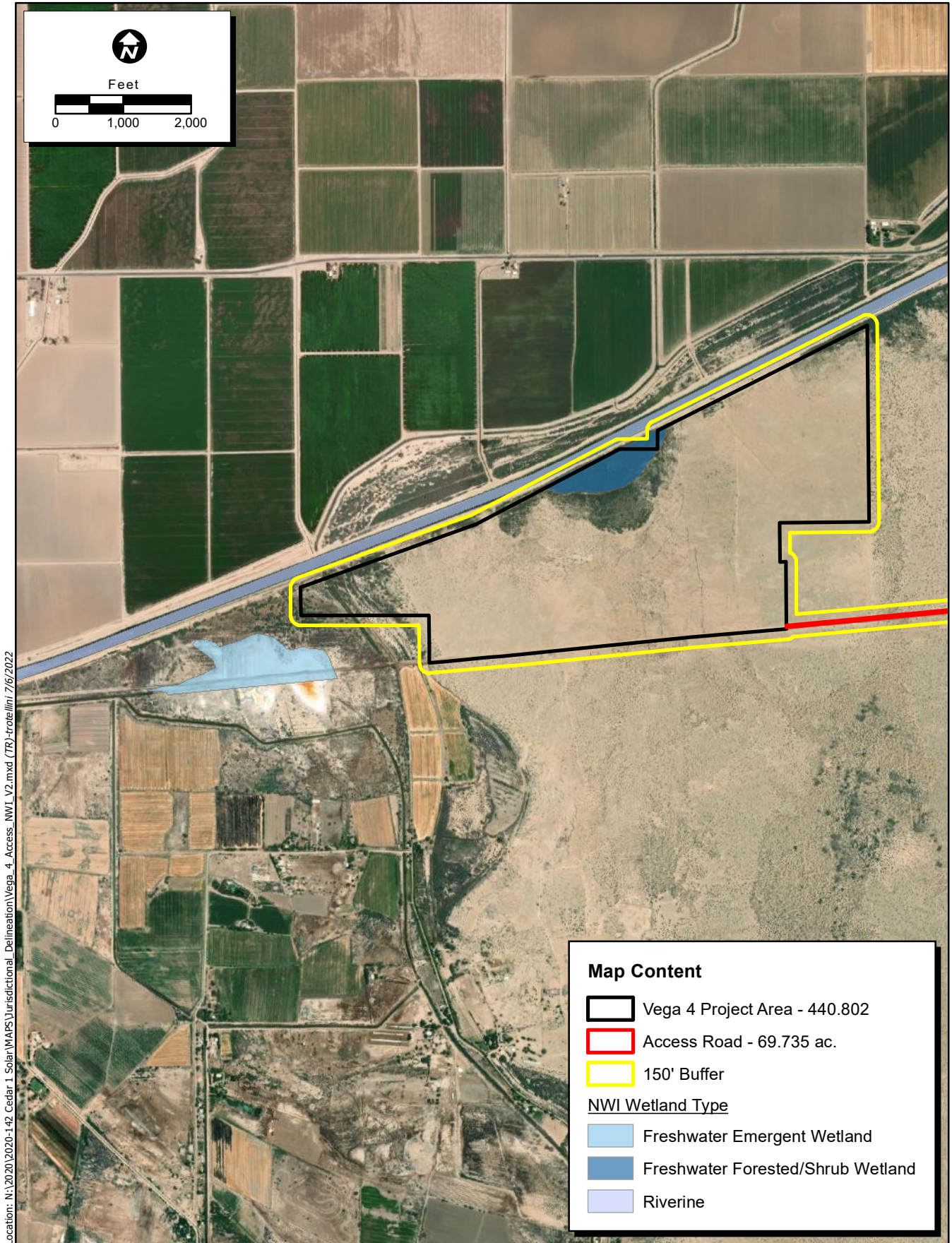
Location: N:\2020\2020-142_Cedar 1 Solar\WAPS\Soils_and_Geology\Vega_4_Access_Soils_ARD_V2.mxd (TR)-tristellini, 7/6/2022

Map Date: 7/6/2022

Service Layer Credits: Source: Esri, Maxar, Earthstar Geographics, and the GIS User Community

Figure 3. Natural Resources Conservation Service Soil Types - Sheet 9 of 9

2020-142 Vega SES 4



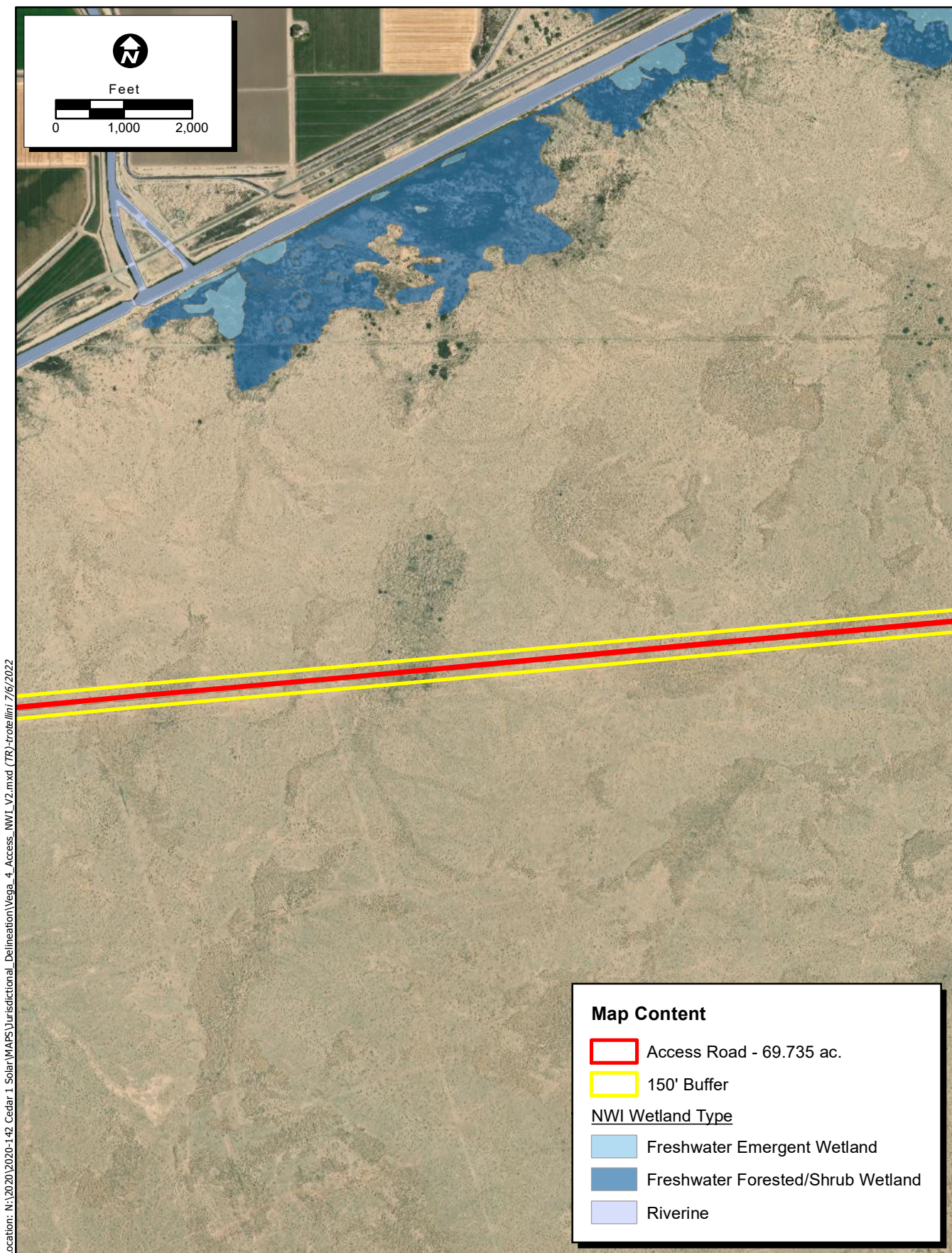
Location: N:\2020\2020-142_Cedar_1_Solar\WAPS\Jurisdictional_Delineation\Vega_4_Access_NWI_V2.mxd (TR) - 7/6/2022

Map Date: 7/6/2022

Service Layer Credits: Source: Esri, Maxar, Earthstar Geographics, and the GIS User Community

Figure 4. National Wetlands Inventory
Sheet 1 of 9

2020-142 Vega SES 4



Location: N:\2020\2020-142_Cedar 1 Solar\WAPS\Jurisdictional_Delineation\Vega_4_Access_NWI_V2.mxd (TR) created 7/6/2022

Map Date: 7/6/2022
 Service Layer Credits: Source: Esri, Maxar, Earthstar Geographics, and the GIS User Community

Map Content

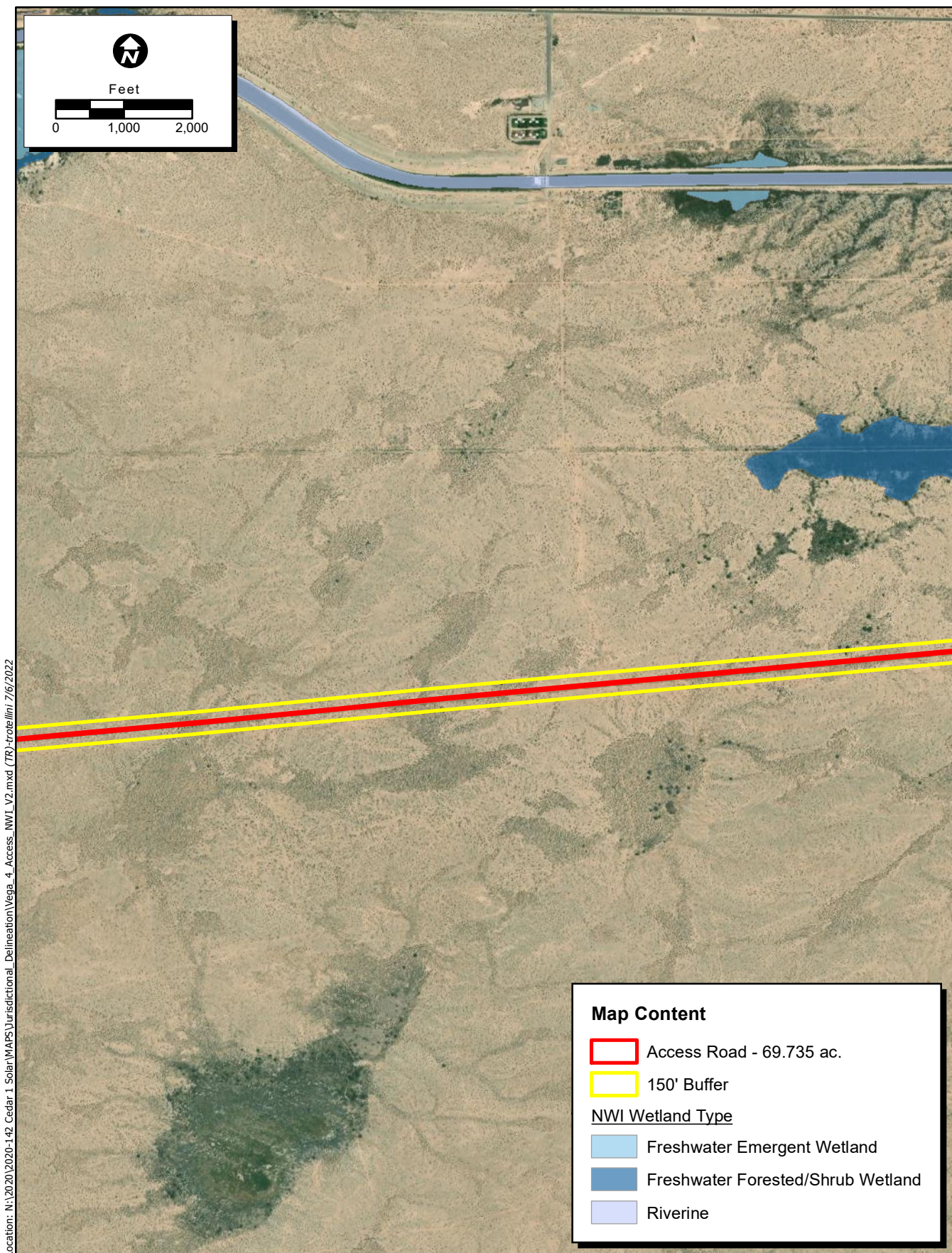
- Access Road - 69.735 ac.
- 150' Buffer

NWI Wetland Type

- Freshwater Emergent Wetland
- Freshwater Forested/Shrub Wetland
- Riverine

Figure 4. National Wetlands Inventory
Sheet 2 of 9

2020-142 Vega SES 4



Location: N:\2020\2020-142_Cedar 1 Solar\WAPS\Jurisdictional_Delineation\Vega_4_Access_NWI_V2.mxd (TR) - created 7/6/2022

Map Content

- Access Road - 69.735 ac.
- 150' Buffer

NWI Wetland Type

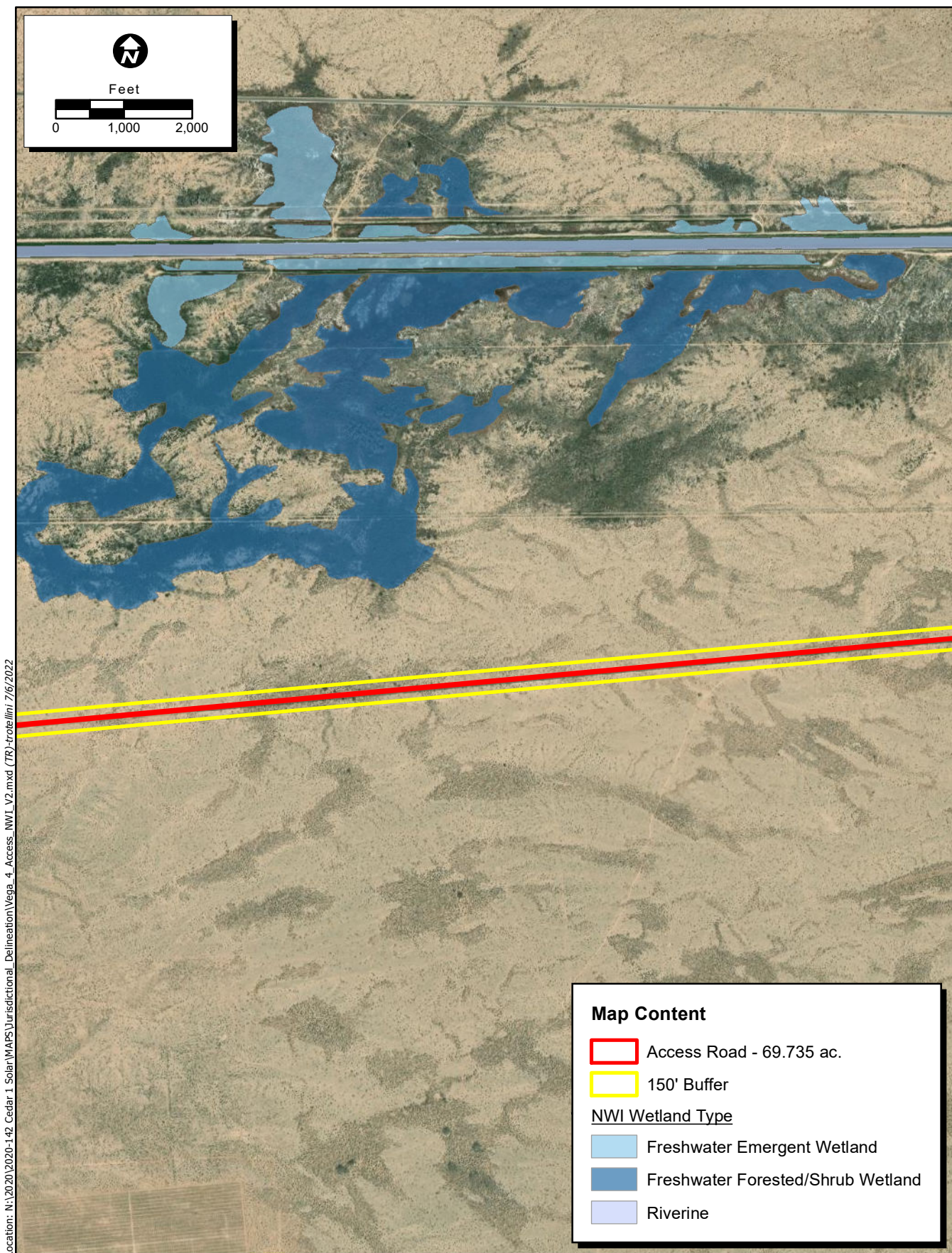
- Freshwater Emergent Wetland
- Freshwater Forested/Shrub Wetland
- Riverine

Map Date: 7/6/2022

Service Layer Credits: Source: Esri, Maxar, Earthstar Geographics, and the GIS User Community

**Figure 4. National Wetlands Inventory
Sheet 3 of 9**

2020-142 Vega SES 4



Location: N:\2020\2020-142_Cedar 1 Solar\WAPS\Jurisdictional_Delineation\Vega_4_Access_NWI_V2.mxd (TRY) created 7/6/2022

Map Content

- Access Road - 69.735 ac.
- 150' Buffer

NWI Wetland Type

- Freshwater Emergent Wetland
- Freshwater Forested/Shrub Wetland
- Riverine

Map Date: 7/6/2022

Service Layer Credits: Source: Esri, Maxar, Earthstar Geographics, and the GIS User Community

**Figure 4. National Wetlands Inventory
Sheet 4 of 9**

2020-142 Vega SES 4

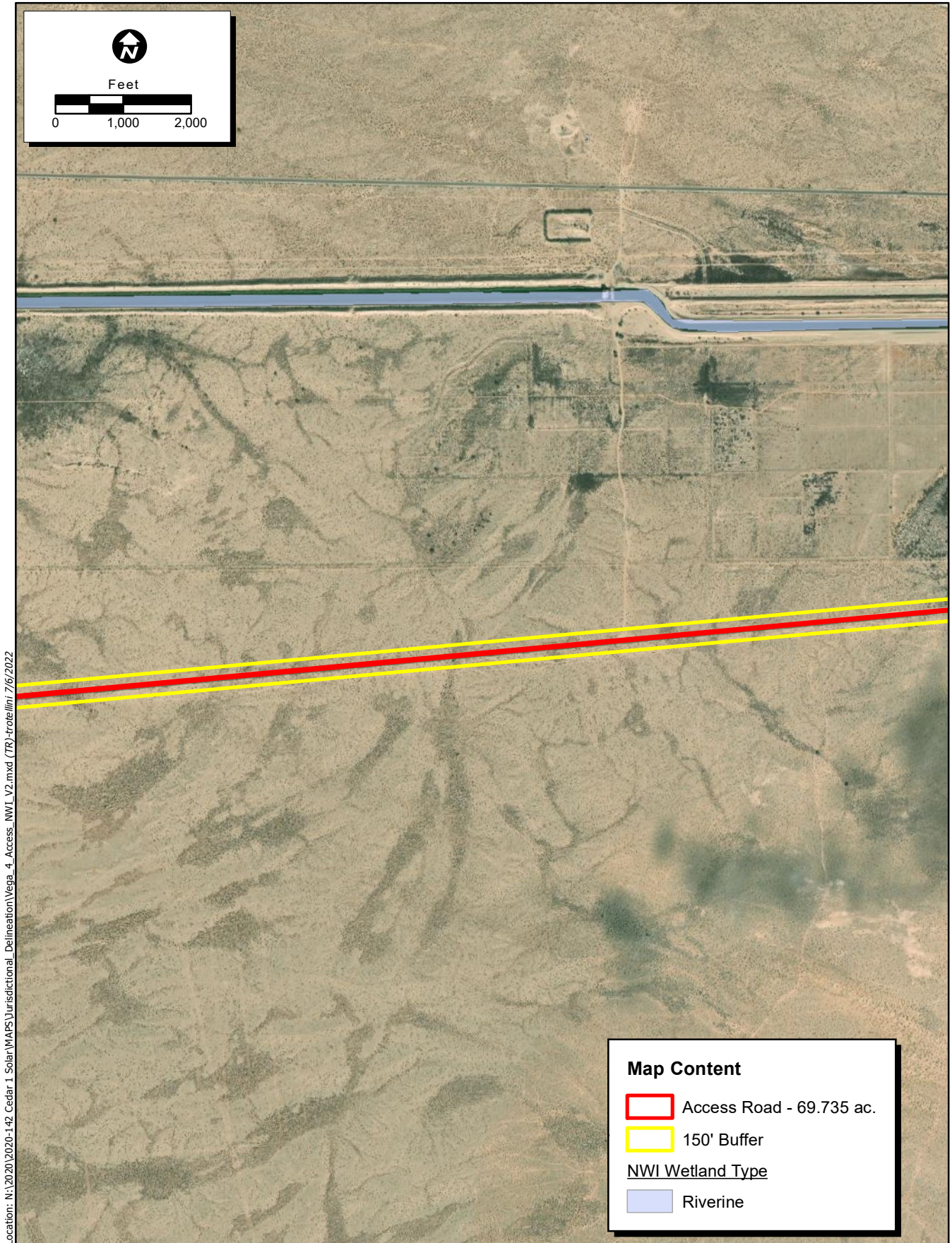


Figure 4. National Wetlands Inventory
Sheet 5 of 9

2020-142 Vega SES 4

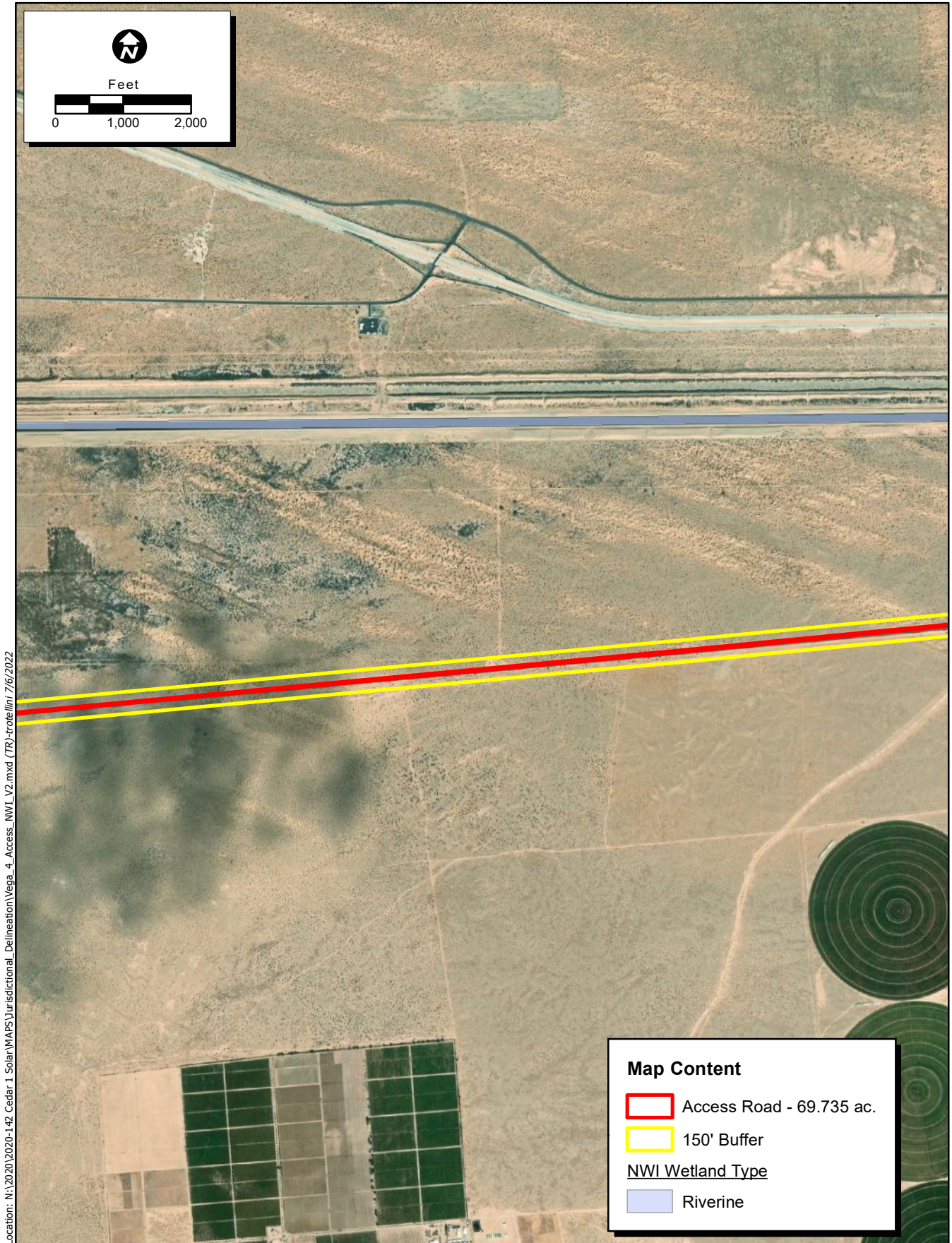
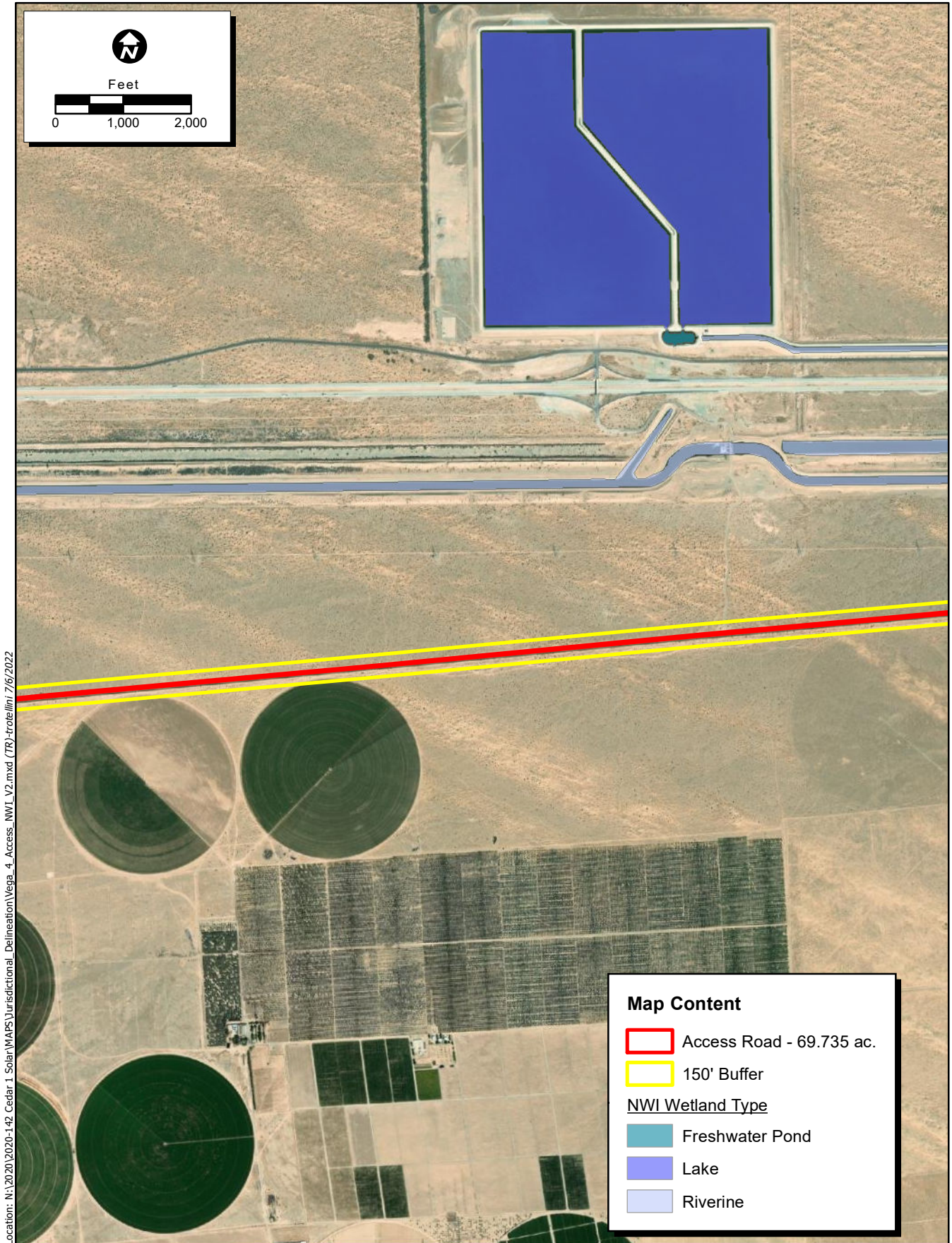


Figure 4. National Wetlands Inventory
Sheet 6 of 9

2020-142 Vega SES 4



Location: N:\2020\2020-142_Cedar 1 Solar\WAPS\Jurisdictional_Delineation\Vega_4_Access_NWI_V2.mxd (TR) - created 7/6/2022

Map Date: 7/6/2022

Service Layer Credits: Source: Esri, Maxar, Earthstar Geographics, and the GIS User Community

Figure 4. National Wetlands Inventory
Sheet 7 of 9

2020-142 Vega SES 4



Location: N:\2020\2020-142_Cedar 1 Solar\WAPS\Jurisdictional_Delineation\Vega_4_Access_NWI_V2.mxd (TR) - created 7/6/2022

Map Date: 7/6/2022

Service Layer Credits: Source: Esri, Maxar, Earthstar Geographics, and the GIS User Community

Map Content	
	Access Road - 69.735 ac.
	150' Buffer
NWI Wetland Type	
	Riverine

Figure 4. National Wetlands Inventory
Sheet 8 of 9

2020-142 Vega SES 4



**Figure 4. National Wetlands Inventory
 Sheet 9 of 9**

2020-142 Vega SES 4

4.1.4 Hydrology

The Study Area is within the Salton Sea watershed (Hydrologic Unit Code [HUC] #18100204) and within the Ash Main Canal-Alamo River (HUC-12 #181002040802), Gordons Well (HUC-12 #181002040402), and Grays Well (HUC-12 #181002040701) subwatersheds (NRCS, et al. 2022). The Study Area is downslope of the All-American Canal, which transports water from the Colorado River at the Imperial Dam and subsequently supplies it to the Imperial Valley through smaller lateral canals, all of which ultimately drain to the Salton Sea. The Salton Sea is a Traditional Navigable Water (TNW) per Section 404 of the CWA (USACE 2001).

Runoff from adjacent agricultural land collects and is concentrated in the solar field portion of the Study Area. Runoff within the planned solar field generally flows south from the direction of the All-American Canal, toward the U.S.-Mexico border, and eventually drains into a playa located west of the Project. Manmade berms running north-south line ephemeral drainages present throughout the western portion of the planned solar field. The All-American Canal and groundwater seepage likely feed the drainages and wetlands present onsite. This historical system dates back as early as 1953 (Nationwide Environmental Title Research Online [NETROnline] 2022) and is possibly remnant of a historic lakebed belonging to Lake Cahuilla.

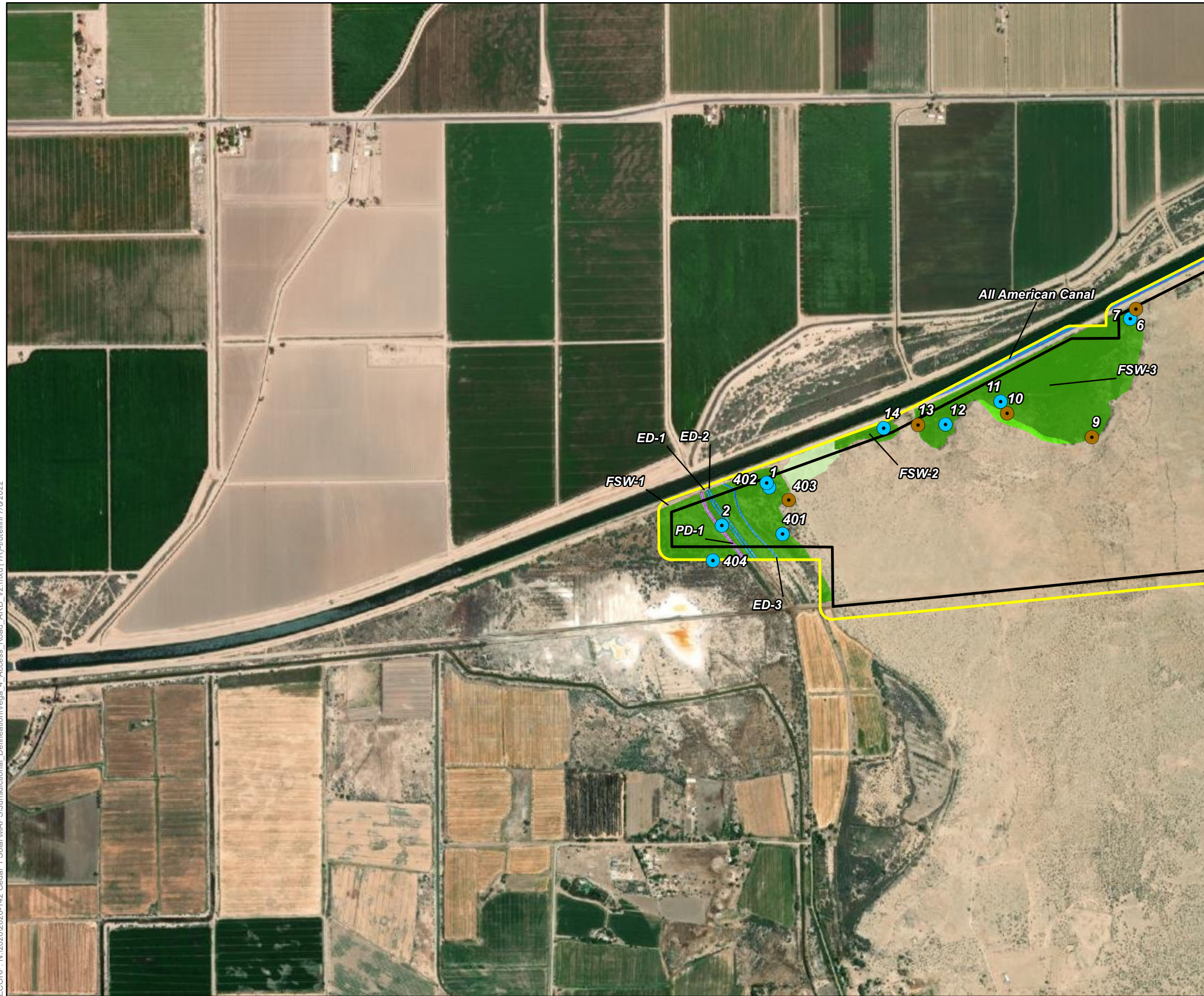
The access road runs parallel to the U.S./Mexico border and is heavily trafficked by U.S. Border Patrol vehicles. One large NWI-mapped wetland system is located approximately 0.25 mile north of the access road, and what appears to be a second wetland system is located approximately 0.10 miles north of the access road. Both wetland systems are assumed to be supported by overlapping NHD-mapped ephemeral streams (USGS 2022) and are possibly remnant of a historic lakebed belonging to Lake Cahuilla. Directly adjacent to the access road, there are two areas of riparian habitat that appear to be remnant wetlands based on the density of dead tamarisk and presence of arrow weed. Both remnant wetlands connect to what is assumed to be an active wetland located directly to the north, and it is likely these remnant wetlands were at one point fed by this active system. Both the active and remnant systems appear in historic aerials dating as far back as 1985 (NETROnline 2022).

4.2 Aquatic Resources

Aquatic resources have been mapped within the Study Area; these results are subject to agency verification. Aquatic resources that fall within the Project boundaries are summarized by feature in Table 5 and depicted on Figure 5.

Features identified as an aquatic resource had wetland indicators present and/or physical evidence of flow including OHWM, defined bed and bank, presence of a clear and natural line impressed on the bank, the presence or absence of sediment deposits, litter/debris, and/or exposed roots indicating active hydrology within the channel. Associated riparian habitat identified within the Study Area consisted of hydrophytic vegetation and hydrological indicators but lacked hydric soil indicators. The OHWM and wetland determination data forms are included as Attachment B, representative site photographs are included as Attachment C, and the USACE Operations and Maintenance Business Information Link Regulatory Module (ORM) aquatic resources table is included as Attachment D.

ECORP: N:\2020\2020-142 Cedar 1 Solar\MAPS\Jurisdictional Delineation\Vega 4_Access_Road_ARD_V2.mxd (TR)-rotellini 7/6/2022



Map Features

- Vega 4 Project Area - 440.802
- 150' Buffer
- Upland Point
- Waters Point

CDFW-Regulated Habitat

- Disturbed Riparian Habitat
- Riparian Habitat

Aquatic Resources

- Canal - Bank-to-Bank (No Impacts)
- Canal - OHWM (No Impacts)
- Perennial Drainage - Bank-to-Bank
- Perennial Drainage - OHWM
- Ephemeral Drainage - Bank-to-Bank
- Ephemeral Drainage - OHWM
- Forested Shrub Wetland

Service Layer Credits: Sources: Esri, HERE, Garmin, USGS, Intermap, INCREMENT P, NRCan, Esri Japan, METI, Esri China (Hong Kong), Esri Korea, Esri (Thailand), NGCC, (c) OpenStreetMap contributors, and the GIS User Community

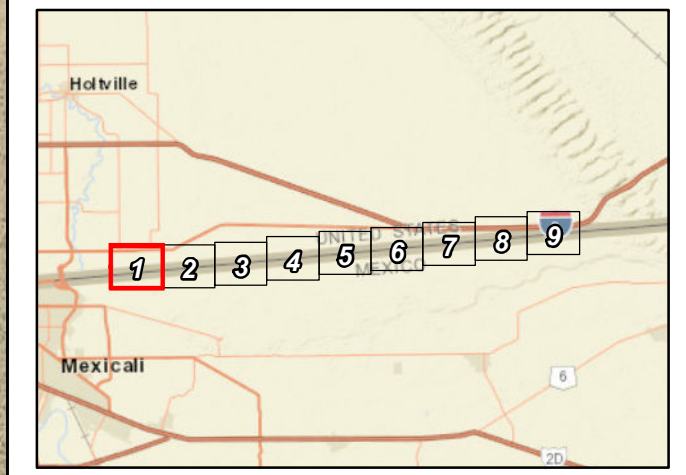
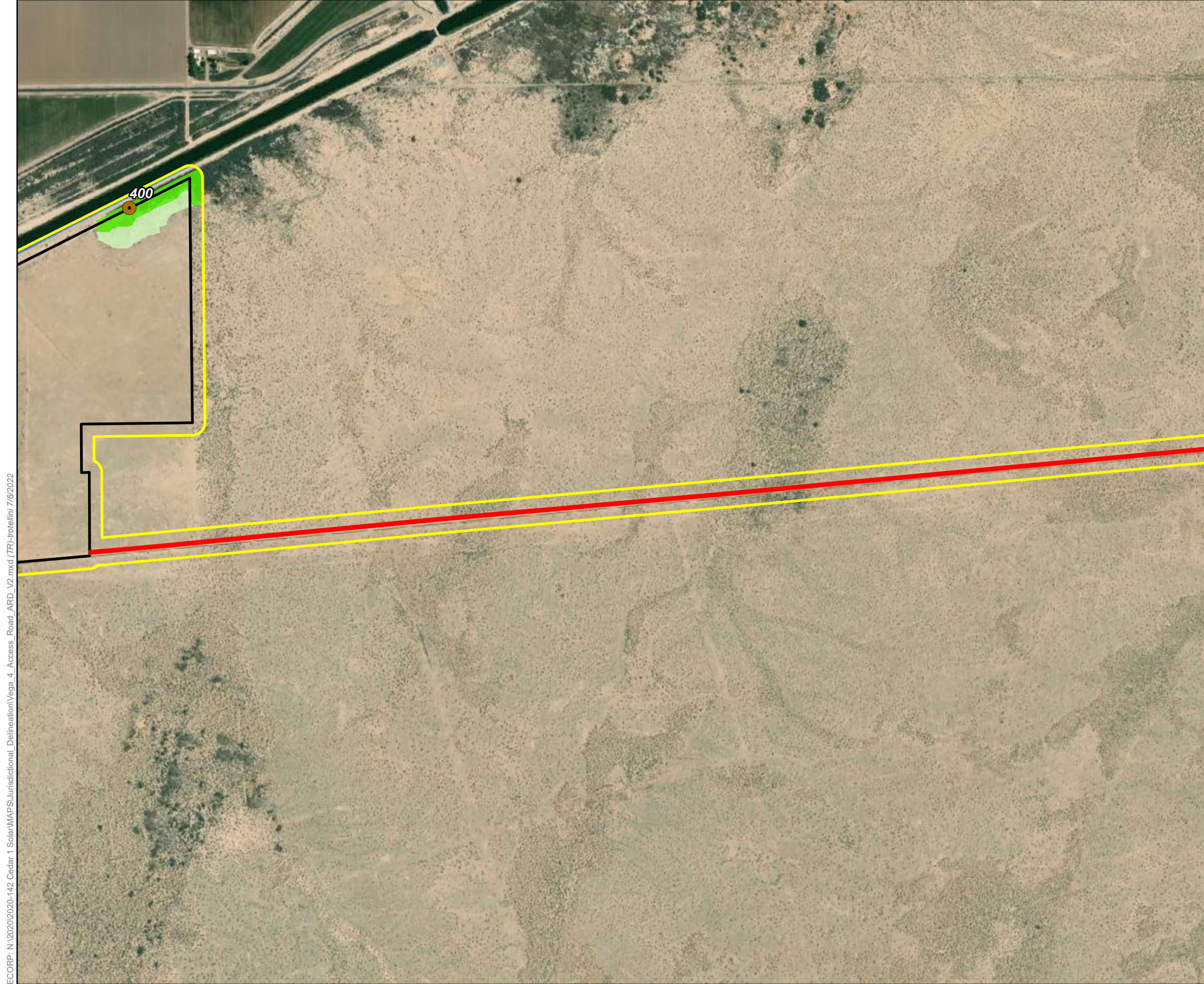


Figure 5. Aquatic Resources Delineation
Sheet 1 of 9
2020-142 Vega SES 4



- Map Features**
- Vega 4 Project Area - 440.802
 - Access Road - 69.735 ac.
 - 150' Buffer
 - Upland Point
- CDFW-Regulated Habitat**
- Disturbed Riparian Habitat
 - Riparian Habitat
- Aquatic Resources**
- Canal - Bank-to-Bank (No Impacts)
 - Canal - OHWM (No Impacts)

ECORP: N:\2020\2020-142 Cedar 1 Solar\MAPS\Jurisdictional_Delineation\Vega_4_Access_Road_ARC_V2.mxd (TR)-rotellini 7/6/2022

Service Layer Credits: Sources: Esri, HERE, Garmin, USGS, Intermap, INCREMENT P, NRCan, Esri Japan, METI, Esri China (Hong Kong), Esri Korea, Esri (Thailand), NGCC, (c) OpenStreetMap contributors, and the GIS User Community

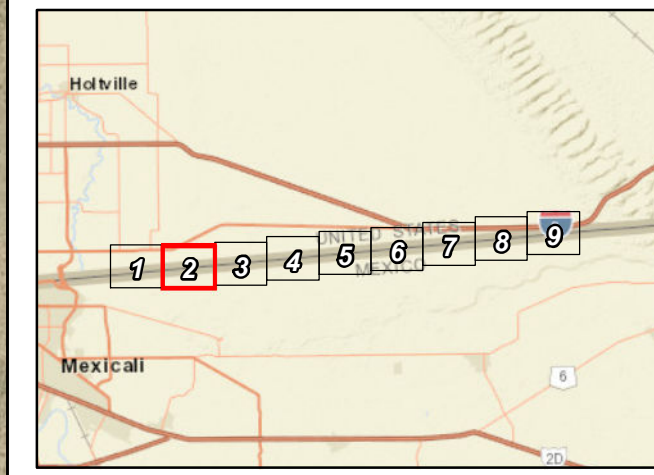
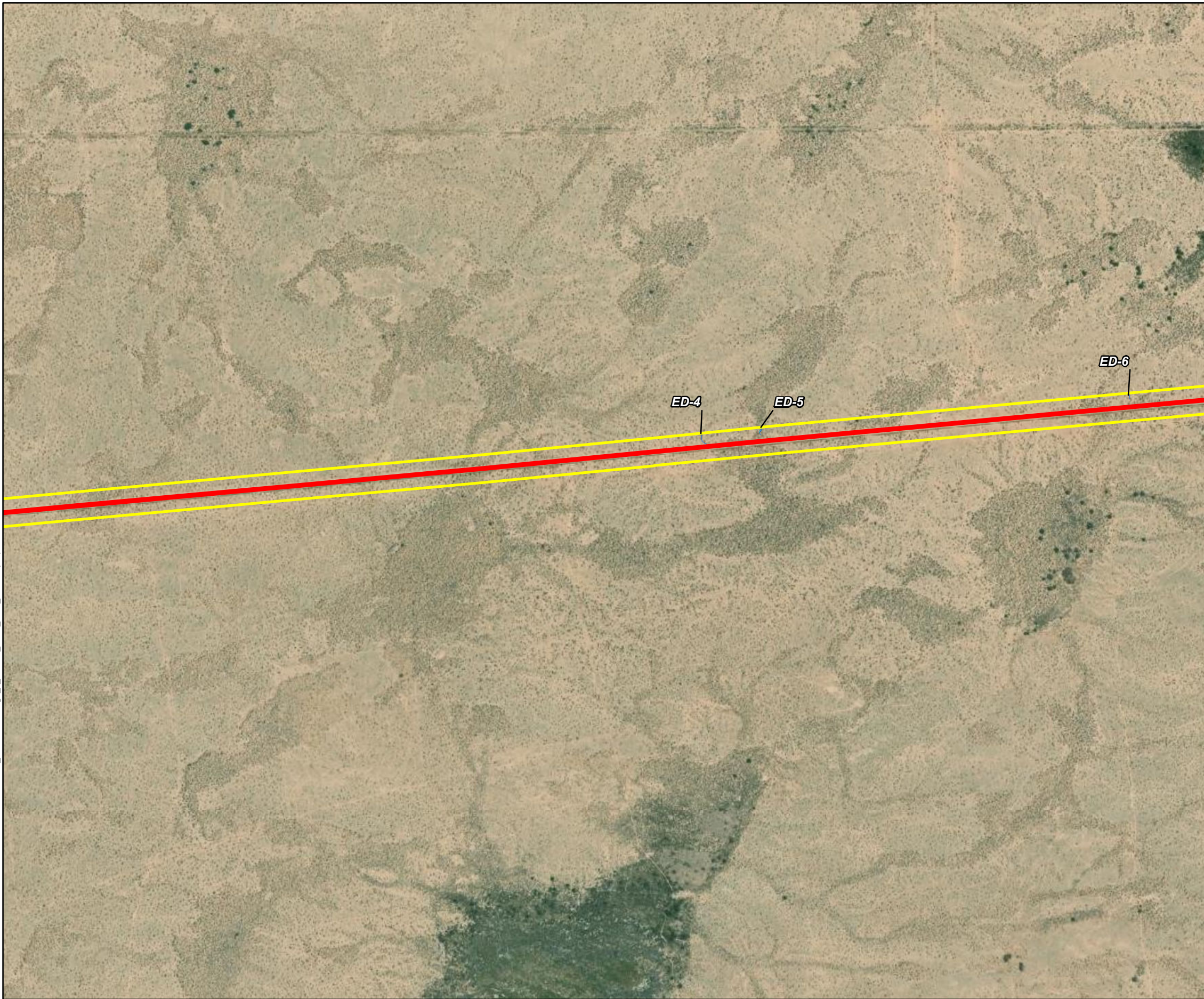


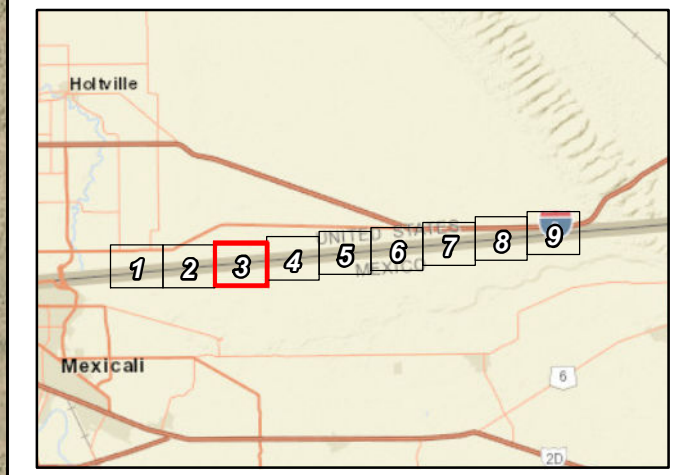
Figure 5. Aquatic Resources Delineation
Sheet 2 of 9
 2020-142 Vega SES 4

ECORP: N:\2020\2020-142 Cedar 1 Solar\MAPS\Jurisdictional_Delineation\Vega_4_Access_Road_ARC_V2.mxd (TR)-trotellini 7/6/2022



- Map Features**
- Access Road - 69.735 ac.
 - 150' Buffer
- Aquatic Resources**
- Ephemeral Drainage - Bank-to-Bank
 - Ephemeral Drainage - OHWM

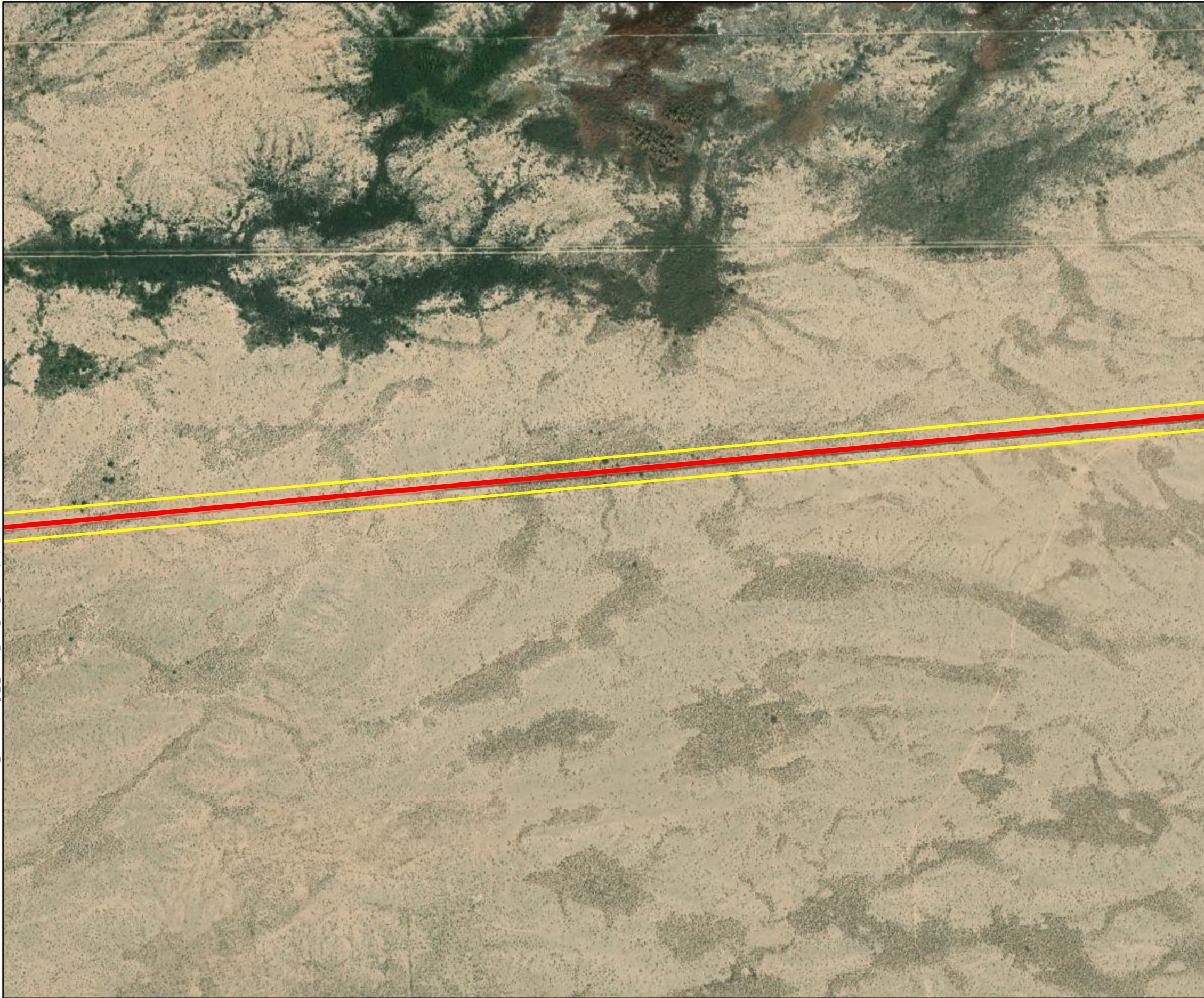
Service Layer Credits: Sources: Esri, HERE, Garmin, USGS, Intermap, INCREMENT P, NRCan, Esri Japan, METI, Esri China (Hong Kong), Esri Korea, Esri (Thailand), NGCC, (c) OpenStreetMap contributors, and the GIS User Community





Map Date: 7/6/2022



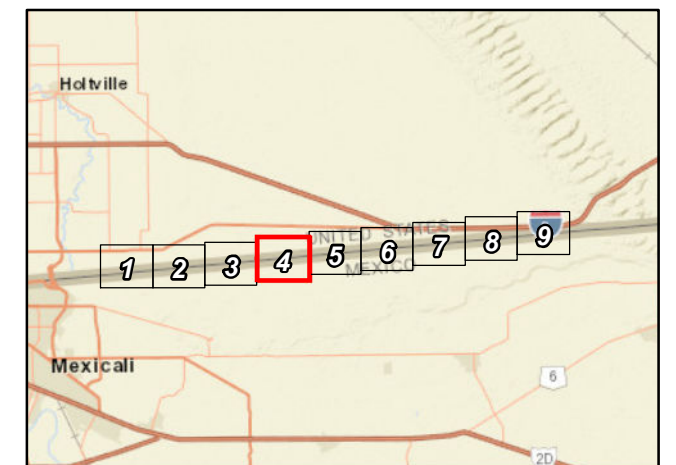
ECORP: N:\2020\2020-142 Cedar 1 Solar\MAPS\Jurisdictional Delineation\Vega_4_Access_Road_ARC_V2.mxd (TR)-rotellini 7/6/2022



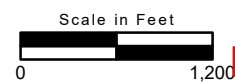
Map Features

-  Access Road - 69.735 ac.
-  150' Buffer

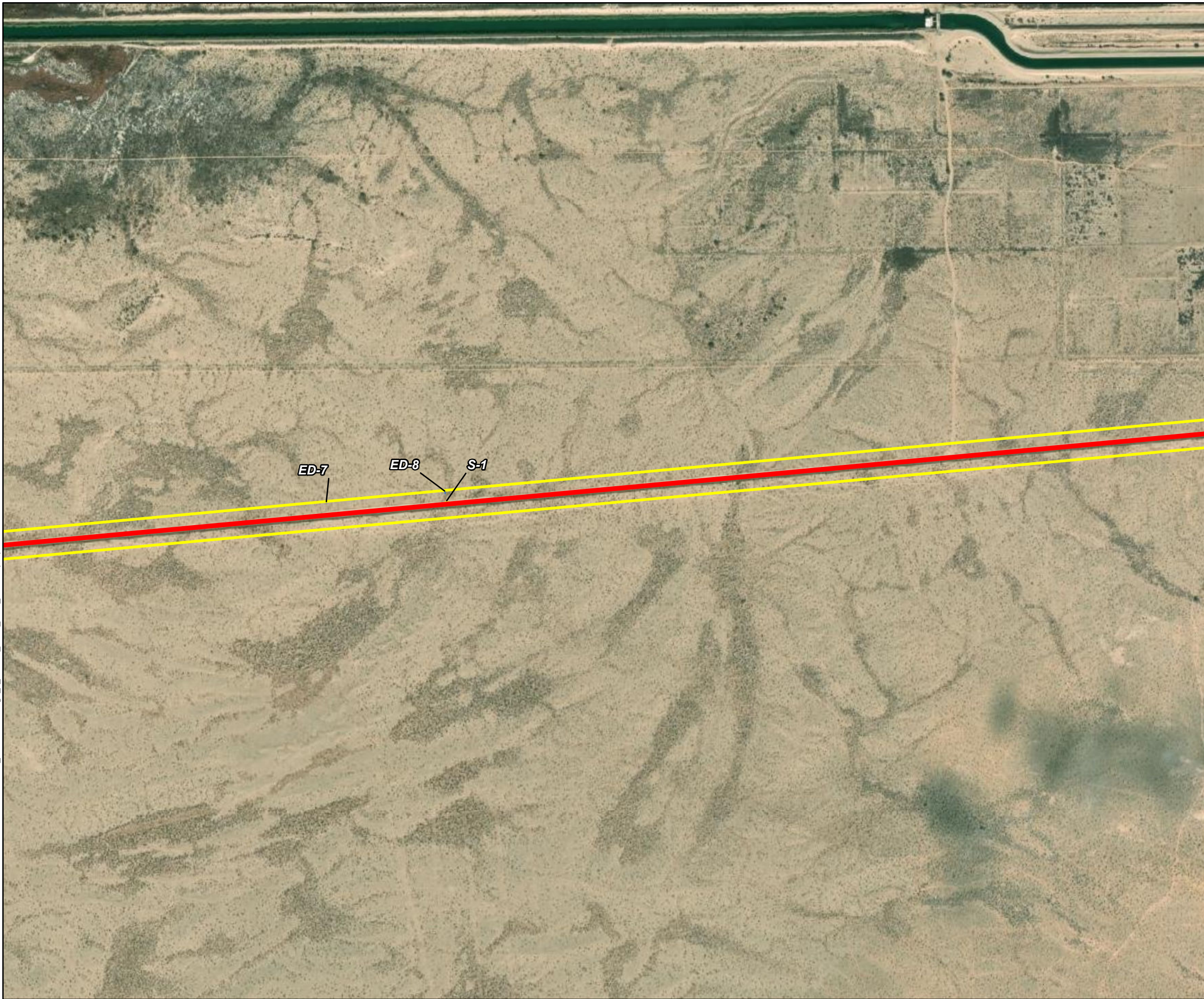
Service Layer Credits: Sources: Esri, HERE, Garmin, USGS, Intermap, INCREMENT P, NRCan, Esri Japan, METI, Esri China (Hong Kong), Esri Korea, Esri (Thailand), NGCC, (c) OpenStreetMap contributors, and the GIS User Community



Map Date: 7/6/2022

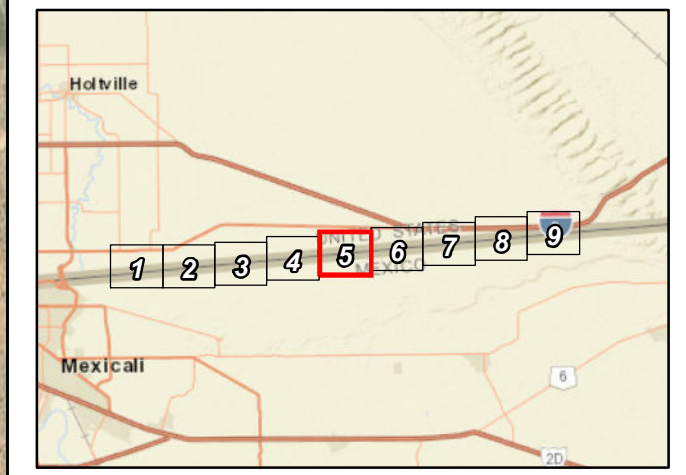


ECORP: N:\2020\2020-142 Cedar 1 Solar\MAPS\Jurisdictional Delineation\Vega_4_Access_Road_ARC_V2.mxd (TR)\rotellini 7/6/2022

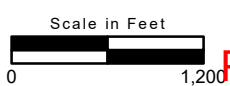


- Map Features**
- Access Road - 69.735 ac.
 - 150' Buffer
- Aquatic Resources**
- Swale - Bank to Bank
 - Swale - OHWM
 - Ephemeral Drainage - Bank-to-Bank
 - Ephemeral Drainage - OHWM

Service Layer Credits: Sources: Esri, HERE, Garmin, USGS, Intermap, INCREMENT P, NRCan, Esri Japan, METI, Esri China (Hong Kong), Esri Korea, Esri (Thailand), NGCC, (c) OpenStreetMap contributors, and the GIS User Community

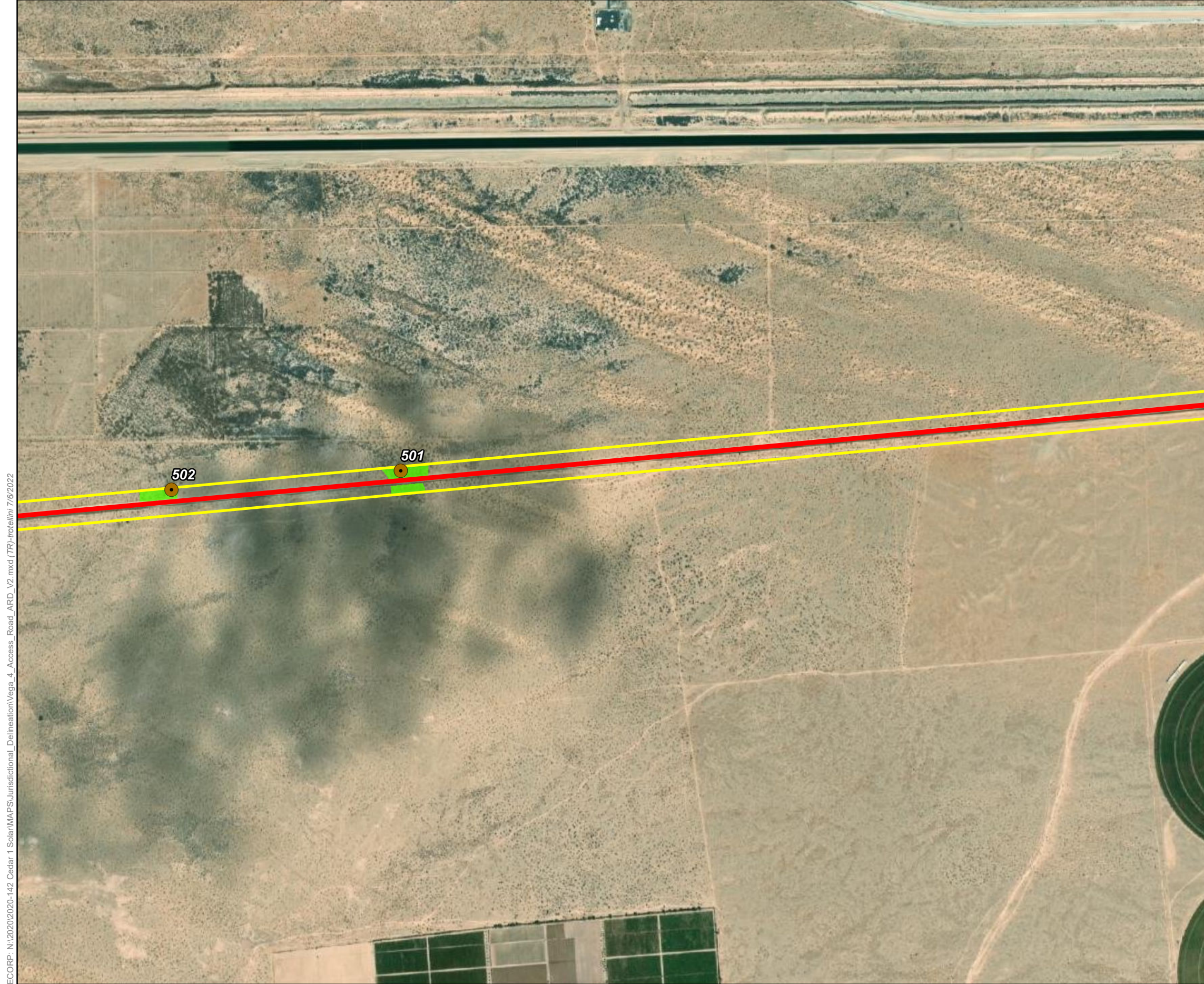


Map Date: 7/6/2022



PC ORIGINAL PKG

Figure 5. Aquatic Resources Delineation Sheet 5 of 9 2020-142 Vega SES 4



- Map Features**
- Access Road - 69.735 ac.
 - 150' Buffer
 - Upland Point
- CDFW-Regulated Habitat**
- Riparian Habitat

ECORP: N:\2020\2020-142 Cedar 1 Solar\MAPS\Jurisdictional_Delineation\Vega_4_Access_Road_ARD_V2.mxd (TR)-frotellini 7/6/2022

Service Layer Credits: Sources: Esri, HERE, Garmin, USGS, Intermap, INCREMENT P, NRCan, Esri Japan, METI, Esri China (Hong Kong), Esri Korea, Esri (Thailand), NGCC, (c) OpenStreetMap contributors, and the GIS User Community

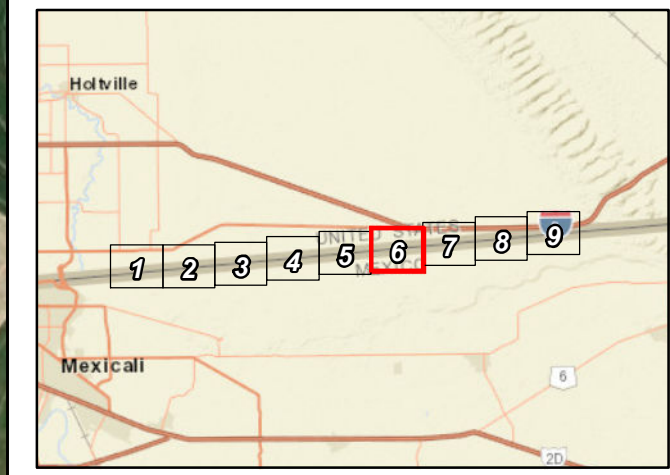


Figure 5. Aquatic Resources Delineation
Sheet 6 of 9
 2020-142 Vega SES 4



- Map Features**
- Access Road - 69.735 ac.
 - 150' Buffer

ECORP: N:\2020\2020-142 Cedar 1 Solar\MAPS\Jurisdictional_Delineation\Vega_4_Access_Road_ARD_V2.mxd (TR)-rotellini 7/6/2022

Service Layer Credits: Sources: Esri, HERE, Garmin, USGS, Intermap, INCREMENT P, NRCan, Esri Japan, METI, Esri China (Hong Kong), Esri Korea, Esri (Thailand), NGCC, (c) OpenStreetMap contributors, and the GIS User Community

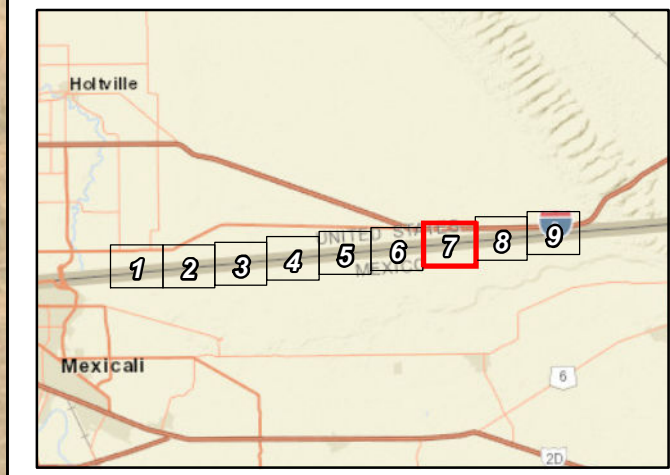




Figure 5. Aquatic Resources Delineation
Sheet 7 of 9
 2020-142 Vega SES 4

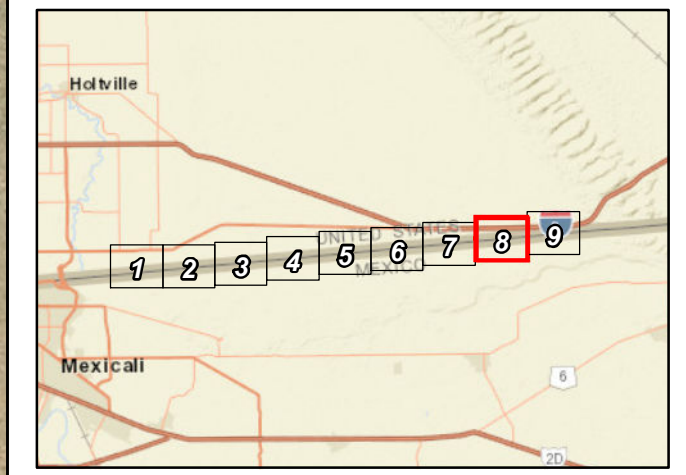
ECORP: N:\2020\2020-142 Cedar 1 Solar\MAPS\Jurisdictional_Delineation\Vega_4_Access_Road_ARD_V2.mxd (TR)-rotellini 7/6/2022



Map Features

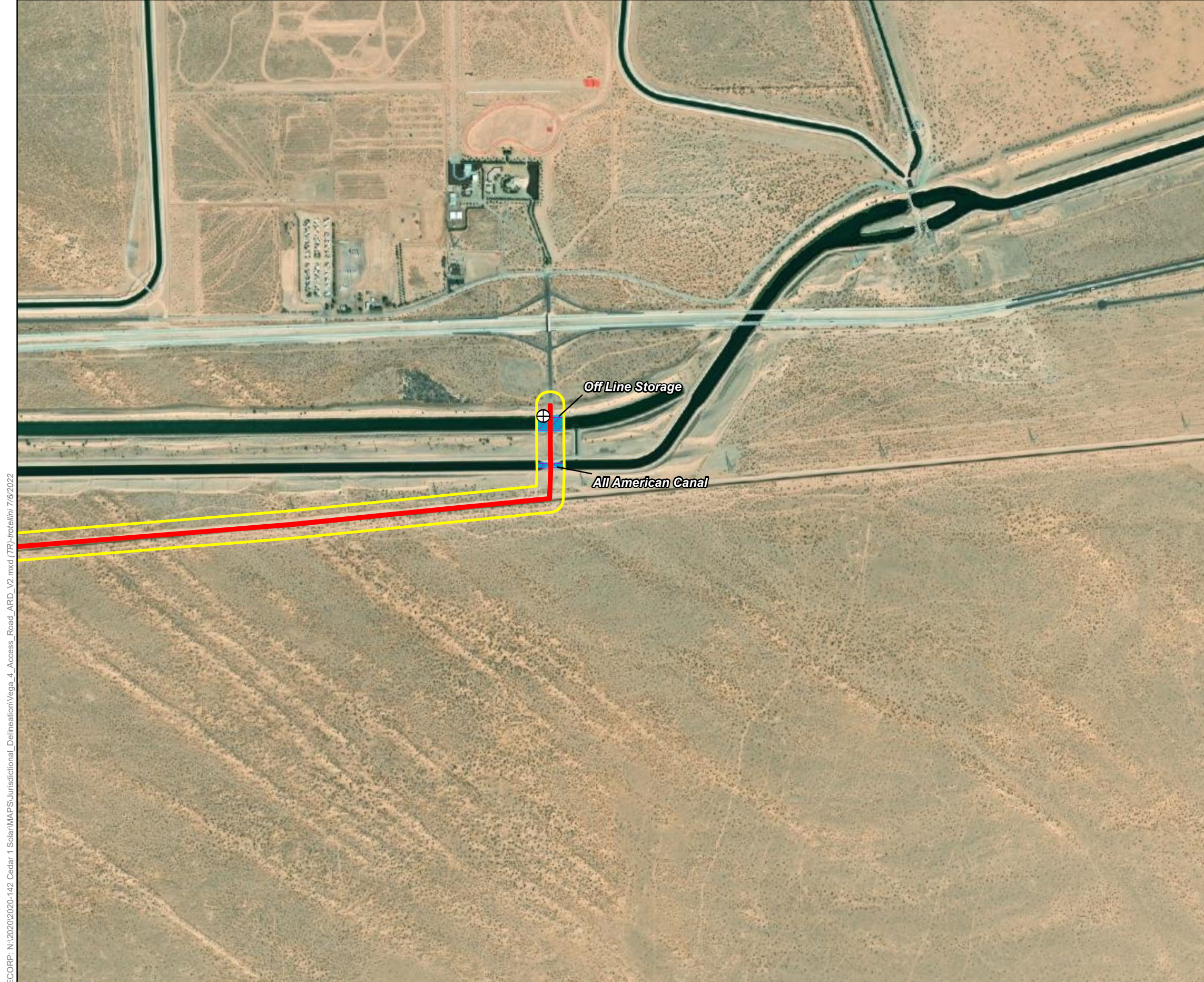
-  Access Road - 69.735 ac.
-  150' Buffer

Service Layer Credits: Sources: Esri, HERE, Garmin, USGS, Intermap, INCREMENT P, NRCan, Esri Japan, METI, Esri China (Hong Kong), Esri Korea, Esri (Thailand), NGCC, (c) OpenStreetMap contributors, and the GIS User Community



Map Date: 7/6/2022





- Map Features**
- Access Road - 69.735 ac.
 - 150' Buffer
 - ⊕ OWHM Cross Section
- Aquatic Resources**
- Canal - Bank-to-Bank (No Impacts)
 - Canal - OWHM (No Impacts)

ECORP: N:\2020\2020-142 Cedar 1 Solar\MAPS\Jurisdictional Delineation\Vega_4_Access_Road_ARC_V2.mxd (TR)-rotellini 7/6/2022

Service Layer Credits: Sources: Esri, HERE, Garmin, USGS, Intermap, INCREMENT P, NRCan, Esri Japan, METI, Esri China (Hong Kong), Esri Korea, Esri (Thailand), NGCC, (c) OpenStreetMap contributors, and the GIS User Community

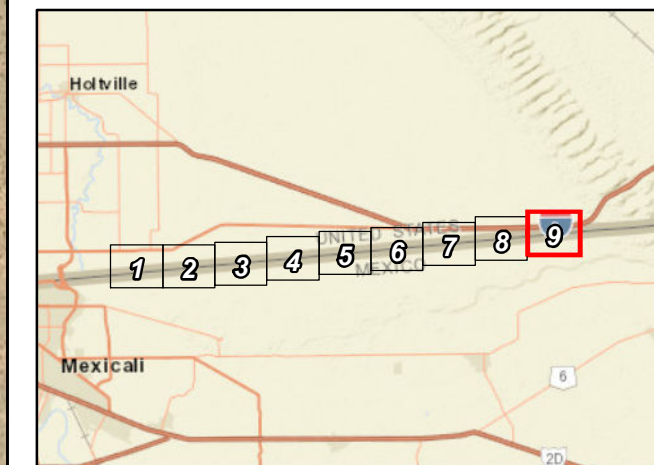


Figure 5. Aquatic Resources Delineation
Sheet 9 of 9
 2020-142 Vega SES 4

Table 5. Aquatic Resources within the Project								
Resource Name ¹	Aquatic Resources Classification		OHWM/Wetland Presence Summary	Dominant Vegetation	WOTUS/WSC Size (acres) ³	CDFW Size (acres) ⁴	Resource Size (linear feet)	Riparian Habitat Size (acres)
	Cowardin ²	Location (latitude, longitude)						
ED-1	R6	32.67954541, -115.31681051	OHWM indicators: defined bed and bank and vegetation matted down, bent, or absent.	Tamarisk Thickets	0.282	0.275	701.547	N/A
ED-2	R6	32.67977819, -115.31686094	OHWM indicators: defined bed and bank and vegetation matted down, bent, or absent.	Tamarisk Thickets	0.288	0.357	717.545	N/A
ED-3	R6	32.67983223, -115.31627266	OHWM indicators: defined bed and bank.	Tamarisk Thickets	0.231	0.415	806.879	N/A
FSW-1	PSS1C	32.67960789, -115.31829880	Wetland criteria met: hydrophytic vegetation present, hydric soils present, and hydrological indicators present.	Tamarisk Thickets	18.401	N/A	N/A	N/A
FSW-2	PSS1C	32.68345488, -115.31168036	Wetland criteria met: hydrophytic vegetation present, hydric soils present, and hydrological indicators present.	Tamarisk Thickets	0.372	N/A	N/A	N/A
FSW-3	PSS1C	32.68496608, -115.30521625	Wetland criteria met: hydrophytic vegetation present, hydric soils present, and hydrological indicators present.	Tamarisk Thickets	40.344	N/A	N/A	N/A
PD-1	R2AB3H	32.67989722, -115.31746236	Wetland criteria met within the channel with OHWM indicators; bisects wetland riparian habitat.	Tamarisk Thickets	0.343	0.687	664.876	2.527
Unassociated Riparian Habitat	N/A	32.68384969, -115.30666666	N/A	Arrow Weed and Tamarisk thickets	5.793	N/A	N/A	N/A
Unassociated Disturbed Riparian Habitat	N/A	32.69004265, -115.29438590	N/A	Disturbed Arrow Weed Thickets	N/A	N/A	N/A	5.696
All American Canal ⁵	R2UBHx	32.70397136, -114.95717380	N/A	Unvegetated	0.029	0.037	24.996	N/A
Off Line Storage ⁵	R2UBHx	32.70532216, -114.95718630	N/A	Unvegetated	0.086	0.115	24.971	N/A
Total:					66.169	1.886	2940.815	

1: ED= Ephemeral Drainage, FSW= Freshwater Forested/Shrub Wetland, PD= Perennial Drainage.

2: Cowardin Codes: (R6) Riverine, ephemeral; (PEM1C) Freshwater Emergent Wetland; (PSS1C) Freshwater Forested/Shrub Wetland; (R2AB3H) Riverine, lower perennial, aquatic bed, rooted vascular; (R2UBHx) Riverine, Lower Perennial, Unconsolidated Bottom, Permanently Flooded, Excavated (USFWS 2022b).

3: OHWM widths were used to estimate WOTUS (Waters of the U.S.) and WSC (Waters of the State of California) areas.

4: Top- of-Bank widths were used to estimate CDFW acreages.

5: Impacts to these features are not expected to occur, as features flow beneath access road entry bridge.

4.2.1 Wetlands

4.2.1.1 Freshwater Forested/Shrub Wetland

Freshwater forested/shrub wetlands (FSW) are dominated by woody vegetation such as true shrubs, young trees (saplings), and trees or shrubs that are stunted due to environmental conditions. They are seasonally flooded: therefore, surface water is present for extended periods, particularly in the early growing season, but is absent by the end of the growing season in most years. The water table can be variable after a flooding event, and ranges from saturation at the ground surface to a water table well below the ground surface (USFWS 2022a). There are three FSW within the Study Area (FSW-1, FSW-2, and FSW-3; Figure 5).

Sampling Points 1, 2, 401, 402, and 404 were collected in the freshwater forested/shrub wetland in the western portion of the solar field Study Area (FSW-1). Sampling Point 403 was collected outside the limits of FSW-1. At Sampling Point 402, plant species observed included tamarisk, willow baccharis, and arrow weed. Soils were determined to be hydric based on the presence of hydric soil indicators depleted below dark surface (A11) and redox depressions (F8). Wetland hydrology indicators observed at Sampling Point 402 included saturation (A3), drift deposits (B3), and oxidized rhizospheres along living roots (C3).

Sampling Point 14 was collected in the freshwater forested/shrub wetland in the northwestern portion of the solar field Study Area (FSW-2). Plant species observed within the wetland included tamarisk, arrow weed, and screwbean mesquite. Soils were determined to be hydric based on the presence of hydric soil indicator redox depressions (F8). Wetland hydrology indicators observed at Sampling Point 14 included sediment deposits (B2), drift deposits (B3), and water-stained leaves (B9).

Sampling Points 7, 11, and 12 were collected in the FSW in the northeastern portion of the solar field Study Area (FSW-3). Sampling Points 6, 9, 10, and 13 were collected outside the limits of FSW-3. At Sampling Point 7, plant species observed within the wetland included willow baccharis, arrow weed, and cattail. Soils were determined to be hydric based on the presence hydric soil indicator redox depressions (F8). Wetland hydrology indicators observed at Sampling Point 7 included saturation (A3) and water-stained leaves (B9).

4.2.2 Other Aquatic Resources

4.2.2.1 Perennial Drainage

Perennial drainages (PD) are linear features that exhibit a bed and bank and an OHWM. These features typically contain surface water flowing continuously year-round. OHWM indicators observed for the perennial drainage (PD-1) that occurs within the western portion of the Study Area included defined bed and bank, change in vegetation species, change in vegetation cover, and natural line impressed in bank. The existing hydrology of PD-1 supports emergent wetland habitat within the channel.

Sampling Point 2 was collected within the emergent wetland in the bed of PD-1. At Sampling Point 2, plant species observed within the drainage included tamarisk and cattail. Soils were determined to be hydric based on the presence of hydric soil indicators hydrogen sulfide (A4), loamy gleyed matrix (F2), and

redox depressions (F8). Wetland hydrology indicators observed at Sampling Point 2 included surface water (A1), high water table (A2), saturation (A3), and hydrogen sulfide odor (C1).

4.2.2.2 Ephemeral Drainage

Ephemeral drainages (ED) are linear features that exhibit a bed and bank and an OHWM. These features typically convey runoff for short periods of time, during and immediately following rain events, and are not influenced by groundwater sources at any time during the year. The solar field Study Area contains three ephemeral drainages within the western portion of the Project (ED-1, ED-2, and ED-3). These manmade drainages convey flow through the Study Area and into FEW-1. Additional ephemeral drainages exist within the buffer of the access road, but do not overlap with the Study Area.

No sampling points were collected within ephemeral features because soils and vegetation did not imply that wetlands could be present. Wetland hydrology indicators were present at these features, however, leading to the conclusion that they conveyed water irregularly.

4.2.3 Manmade Features

4.2.3.1 Main Canals

A total of two main canals managed by IID, the All-American Canal and the associated Off-line Storage Canal, were identified within the access road portion of the Study Area and are assumed to flow perennially. Both canals bisect the easternmost portion of the Study Area. The concrete-lined All-American Canal is maintained by IID in order to be free of vegetation for water conveyance efficiency. The Off-line Storage Canal is natural-bottomed, and flow and water levels are maintained by IID. The All-American Canal brings water from the Colorado River at the Imperial Dam and supplies it to the Imperial Valley through smaller lateral canals, all of which ultimately drain to the Salton Sea (IID 2022). Because these canals flow underneath the access road entry bridge, no impacts are expected to occur to either canal.

4.2.4 Associated Habitat

4.2.4.1 Riparian Habitat

Both riparian habitat and disturbed riparian habitat are present within the Study Area. They are associated with the floodplain adjacent to the wetlands and drainages throughout the Project. Topographically, these areas sit within a low point. Riparian habitat within the Study Area contains hydrophytic vegetation and hydrological indicators but lack hydric soil indicators, whereas disturbed riparian habitat is riparian habitat that has been previously altered. A total of 5.793 acres of riparian habitat and 8.223 acres of disturbed riparian habitat exists within the Study Area.

Sampling Point 10 was collected in riparian habitat located along FSW-3 within the northern portion of the solar field Study Area. Plant species observed included tamarisk, arrow weed, and alkali goldenbush. Hydric soil indicators were determined to be absent at this sampling point. Wetland hydrology indicators observed at Sampling Point 10 included sediment deposits (B2) and water-stained leaves (B9).

Sampling Point 400 was collected in riparian habitat located within the northeastern portion of the solar field Study Area. Plant species observed included tamarisk, arrow weed, and cattail. Hydric soil indicators were determined to be absent at this sampling point. Wetland hydrology indicators observed at Sampling Point 400 included high water table (A2), saturation (A3), and water marks (B1).

Sampling point 501 was collected in riparian habitat located within the northern buffer area of the access road Study Area. Plant species observed included tamarisk, arrow weed, creosote bush, and alkali goldenbush. Hydric soil indicators and wetland hydrology indicators were determined to be absent at this sampling point.

Sampling point 502 was collected in riparian habitat located within the northern buffer area of the access road Study Area. Plant species observed included tamarisk, arrow weed, and white bursage. Hydric soil indicators were determined to be absent at this sampling point. Wetland hydrology indicators present included surface soil cracks (B6).

5.0 JURISDICTIONAL ASSESSMENT

According to Regulatory Guidance Letter 16-01, an applicant may request a Preliminary Jurisdictional Delineation (PJD) "in order to move ahead expeditiously to obtain a Corps permit authorization where the requestor determines that it is in his or her best interest to do so... even where initial indications are that the aquatic resources on a parcel may not be jurisdictional" (USACE 2016). A significant nexus evaluation is not necessary to obtain a PJD. The following information on connectivity of wetlands and other waters in the Study Area to TNWs is provided should an Approved Jurisdictional Determination be necessary.

The perennial and ephemeral drainages within the Study Area appear to directly or indirectly (via sheet and/or subsurface flow) connect to adjacent wetlands to the west. The wetlands appear to be fed by the All-American Canal and groundwater seepage. The All-American Canal brings water from the Colorado River at the Imperial Dam and supplies it to the Imperial Valley through smaller lateral canals, all of which ultimately drain to the Salton Sea. The Salton Sea is considered TNW (USACE 2001). The wetlands, perennial drainage, and ephemeral drainages within the Study Area would likely be subject to regulation under Section 404 of the CWA. Ultimately, the jurisdictional determination will be made by the USACE. Regardless of federal jurisdiction status, all aquatic resources delineated on site, including riparian habitat, are subject to CDFW and/or RWQCB jurisdiction.

6.0 CONCLUSION

ECORP's mapping of aquatic resources in the Study Area are depicted on Figure 5. Acreages shown in Table 5 represent calculated estimates of the extent of aquatic resources within the Study Area and are subject to modification following USACE review and/or the verification process. Impacts to aquatic features may require permits from several regulatory agencies pursuant to federal and state laws. Wetlands, perennial drainages, and ephemeral drainages present within the Study Area would require a permit pursuant to Section 404 of the CWA (USACE), certification compliance with Section 401 of the CWA (RWQCB) and the Porter-Cologne Act (RWQCB), and a Lake or Streambed Alteration Agreement pursuant to California Fish and Game Code Section 1600 (CDFW). Impacts to any associated riparian habitat within

the aforementioned features are also subject to an agreement pursuant to California Fish and Game Code Sections 1600 and 1602 (CDFW).

7.0 REFERENCES

- Baldwin, B. G., D.H Goldman, D.J. Keil, R. Patterson, T.J. Rosatti, and D.H. Wilken, editors. 2012. The Jepson Manual; Vascular Plants of California, Second Edition. University of California Press, Berkeley, California. 1,519 pp. + app.
- CDFW. 2020. Environmental Review and Permitting. Available online: <https://wildlife.ca.gov/Conservation/Environmental-Review>. Accessed September 16, 2020.
- Environmental Laboratory. 1987. Corps of Engineers Wetlands Delineation Manual. Technical Report Y-87-1. U. S. Army Engineer Waterways Experiment Station. Vicksburg, Mississippi.
- ESRI. "Topographic" [basemap]. Scale Not Given. "World Imagery". Accessed November 30, 2020 and April 20, 2022. <https://ecorpmapping.maps.arcgis.com/home/item.html?id=0563aff34bdf4e0caa51bba3c69817d9>.
- Google Earth. 2018. <https://www.google.com/maps/@34.6457,-116.99432,30433m/data=!3m1!1e3>. Dated April 4, 2018.
- IID. 2022. Water Transportation System. Available online: <https://www.iid.com/water/water-transportation-system>. Accessed April 22, 2022.
- Kollmorgen Instruments Company. 1990. Munsell Soil Color Charts. Kollmorgen Corporation. Baltimore, Maryland.
- Natural Resources Conservation Service (NRCS), U.S. Geological Survey (USGS), U.S. Environmental Protection Agency (USEPA). 2022. Watershed Boundary Dataset for California. Available online: <https://datagateway.nrcs.usda.gov>. Accessed April 23, 2022.
- Natural Resources Conservation Service (NRCS). 2022a. Soil Survey Geographic Database. Available online: <https://websoilsurvey.sc.egov.usda.gov/App/WebSoilSurvey.aspx>. Accessed April 22, 2022.
- _____. 2022b. Soil Data Access Hydric Soils List. Available at <https://www.nrcs.usda.gov/wps/portal/nrcs/main/soils/use/hydric/>. Accessed April 25, 2022.
- _____. 2022c. Official Soil Series Descriptions. Available at <https://www.nrcs.usda.gov/wps/portal/nrcs/main/soils/use/hydric/>. Accessed April 25, 2022.
- NETROnline. 2022. "Historic Aerials." NETR Online, www.historicaerials.com/. Accessed November 30, 2020 and April 28, 2022.
- NOAA. 2022a. NCDC 1981-2010 Climate Normals for El Centro, California. Available Online: <https://www.ncdc.noaa.gov/cdo-web/datatools/normals>. Accessed September 16, 2020 and April 27, 2022.
- _____. 2022b. Climate Date Online: Daily Precipitation Summaries for El Centro 2 SSW, California. Available Online: <https://www.ncdc.noaa.gov/cdo-web/search>. Accessed September 16, 2020 and April 27, 2022.

- USACE. 2022. The Antecedent Precipitation Tool. Available Online: <https://github.com/jDeters-USACE/Antecedent-Precipitation-Tool/releases/tag/v1.0.13>. Accessed April 27, 2022.
- _____. 2018. National Wetland Plant List, version 3.4. USACE Engineer Research and Development Center. Cold Regions Research and Engineering Laboratory, Hanover, NH. Available online: <http://wetland-plants.usace.army.mil/>
- _____. 2017. Minimum Standards for Acceptance of Aquatic Resources Delineation Reports. Dated March 2017. Los Angeles District.
- _____. 2016. Regulatory Guidance Letter 16-01, Jurisdictional Determinations. Dated October 2016.
- _____. 2010. Updated Datasheet for the Identification of the Ordinary High Water Mark (OHWM) in the Arid West Region of the Western United States. K.E. Curtis and R.W. Lichvar. ERDC/CRREL TN-10-1. Hanover, NH: U.S. Army Engineer Research and Development Center.
- _____. 2008a. Regional Supplement to the Corps of Engineers Wetland Delineation Manual: Arid West Region. Ed. J.S. Wakeley, R.W. Lichvar, and C.V. Noble. ERDC/EL TR-06-16. Vicksburg, MS: U.S. Army Engineer Research and Development Center.
- _____. 2008b. A Field Guide to the Identification of the Ordinary High Water Mark (OHWM) in the Arid West Region of the Western United States. R. W. Lichvar and S. M. McColley. ERDC/CRREL TR-08-12. Hanover, NH: U.S. Army Engineer Research and Development Center.
- _____. 2001. Jurisdictional Determination for the Salton Sea and its Tributaries in light of the U.S. Supreme Court Decision in the Solid Waste Agency of Northern Cook County (SWANCC). Dated January 24, 2001. Accessible online: <https://www.spl.usace.army.mil/Missions/Regulatory/Jurisdictional-Determination/Navigable-Waterways/>.
- USEPA. 2021. Navigable Waters Protection Rule: The Antecedent Precipitation Tool (APT). Dated January 21, 2021. Accessed April 27, 2022.
- USGS. 2022. National Hydrography Dataset. Accessible online: <https://www.usgs.gov/national-hydrography/nhdplus-high-resolution>. Accessed April 22, 2022.
- _____. 1976. "Bonds Corner, California" 7.5-minute Quadrangle. Geological Survey. Denver, Colorado.
- _____. 1979. "Midway Well NW, California" 7.5-minute Quadrangle. Geological Survey. Denver, Colorado.
- _____. 1979. "Midway Well, California" 7.5-minute Quadrangle. Geological Survey. Denver, Colorado.
- _____. 1976. "Grays Well, California" 7.5-minute Quadrangle. Geological Survey. Denver, Colorado.
- USFWS. 2022a. National Wetlands Inventory. Accessible online: <https://www.fws.gov/wetlands/>. Accessed September 24, 2020 and April 22, 2022.
- _____. 2022b. National Wetlands Inventory: Wetland Classification Codes. Accessible online: <https://www.fws.gov/wetlands/Data/Wetland-Codes.html>

LIST OF ATTACHMENTS

Attachment A – Driving Directions to Study Area

Attachment B – OHWM and Wetland Determination Data Forms - Arid West

Attachment C – Representative Site Photographs

Attachment D – USACE ORM Aquatic Resources Table

Attachment E – Digital Data

Driving Directions to Study Area



US Army Corps of Engineers
915 Wilshire Blvd, Los Angeles, CA 90017

Get on CA-110 N/Harbor Fwy from S Figueroa St

- 2 min (0.5 mi)

 1. Head southeast on Wilshire Blvd toward S Figueroa St
- 417 ft

 2. Turn left at the 1st cross street onto S Figueroa St
- 0.2 mi

 3. Turn left at the 3rd cross street onto W 5th St
- 174 ft

 4. Keep right at the fork, follow signs for Harbor Fwy/CA-110 N and merge onto CA-110 N/Harbor Fwy
- 0.2 mi

Follow I-10 E to CA-86 S in Indio

- 2 hr 2 min (129 mi)

 5. Merge onto CA-110 N/Harbor Fwy
- 0.5 mi

 6. Take exit 24A toward I-5 S/I-10 E
- 0.5 mi

 7. Use the left lane to merge onto US-101 S
- 453 ft

 8. Keep left to stay on US-101 S
- 1.2 mi

 9. Keep left at the fork to continue on San Bernardino Fwy, follow signs for I-10 E/San Bernardino
- 1.2 mi

 10. Continue onto I-10 E/San Bernardino Fwy
- 12.2 mi

 11. Keep left to stay on I-10 E
- 52.4 mi

 12. Keep left to stay on I-10 E
- 1.5 mi

 13. Keep left to stay on I-10 E
- 59.7 mi
- 1 hr 4 min (66.7 mi)

 14. Keep right to continue on CA-86 S, follow signs for Brawley/El Centro/865 Expy

Follow CA-78, CA-111 S and I-8 E to Bonds Corner Rd. Take exit 128 from I-8 E

- 30 min (30.4 mi)

 15. Use the left 2 lanes to turn left onto CA-78
- 3.4 mi

 16. Use any lane to turn sharply right to stay on CA-78
- 2.9 mi

 17. Continue onto CA-111 S
- 14.3 mi

 18. Take the exit onto I-8 E toward Yuma
- 9.5 mi

 19. Take exit 128 for Bonds Corner Rd
- 0.2 mi

Follow Bonds Corner Rd and CA-98 E to your destination

- 10 min (8.6 mi)

 20. Turn right onto Bonds Corner Rd
- 5.4 mi

 21. Turn left onto CA-98 E
- 3.1 mi

 22. Turn right
- 299 ft

Holtville
California 92250

These directions are for planning purposes only. You may find that construction projects, traffic, weather, or other events may cause conditions to differ from the map results, and you should plan your route accordingly. You must obey all signs or notices regarding your route.

OHWM and Wetland Determination Data Forms – Arid West Region

Arid West Ephemeral and Intermittent Streams OHWM Datasheet

Project: Vega SES 4 Project Number: 2020-142 Stream: PD-1 Investigator(s): C. Torres	Date: 11/05/2020 Town: Holtville Photo begin file#:	Time: 0900-1030 State: CA Photo end file#:
---------------------------------------------------------------------------------------------------------------------------	--------------------------------------------------------------------------------	-----------------------------------------------------------------------

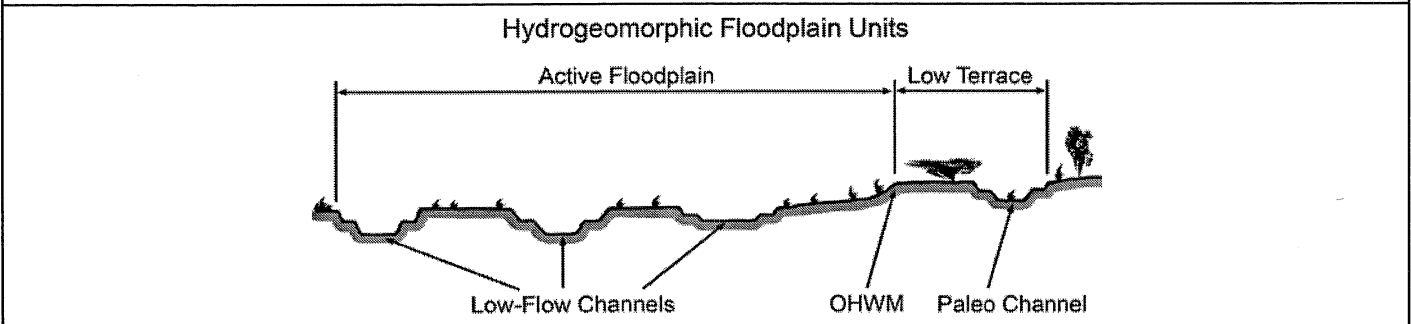
Y <input checked="" type="checkbox"/> / N <input type="checkbox"/> Do normal circumstances exist on the site? Y <input type="checkbox"/> / N <input checked="" type="checkbox"/> Is the site significantly disturbed?	Location Details: South of Salton Sea, directly south of All-American Canal and north of US -Mexico border. Projection: Datum: NAD83 Coordinates:
------------------------------------------------------------------------------------------------------------------------------------------------------------------------------------------------------------------------------	----------------------------------------------------------------------------------------------------------------------------------------------------------------------------------------------------------------------------

Potential anthropogenic influences on the channel system:
 Site priorly used for agriculture and has been previously disturbed/altered. Runoff from adjacent agricultural land collects and is concentrated in the Study Area. Manmade berms line the drainages. Drainage system within a palustrine wetland in western portion of site.

Brief site description:
 The Study Area is downslope of the All-American Canal, which brings water from the Colorado River and likely feeds into the site. Runoff generally flows south from the direction of the All-American Canal and toward the U.S.-Mexico border

Checklist of resources (if available):

<input checked="" type="checkbox"/> Aerial photography Dates: 1953, 1996-2016 (historic aeriels); 11/2020 (sUAS imagery) <input checked="" type="checkbox"/> Topographic maps <input type="checkbox"/> Geologic maps <input checked="" type="checkbox"/> Vegetation maps <input checked="" type="checkbox"/> Soils maps <input type="checkbox"/> Rainfall/precipitation maps <input type="checkbox"/> Existing delineation(s) for site <input checked="" type="checkbox"/> Global positioning system (GPS) <input type="checkbox"/> Other studies	<input type="checkbox"/> Stream gage data Gage number: Period of record: <input type="checkbox"/> History of recent effective discharges <input type="checkbox"/> Results of flood frequency analysis <input type="checkbox"/> Most recent shift-adjusted rating <input type="checkbox"/> Gage heights for 2-, 5-, 10-, and 25-year events and the most recent event exceeding a 5-year event
------------------------------------------------------------------------------------------------------------------------------------------------------------------------------------------------------------------------------------------------------------------------------------------------------------------------------------------------------------------------------------------------------------------------------------------------------------------------------------------------------------------------------------------------------------------------------	-----------------------------------------------------------------------------------------------------------------------------------------------------------------------------------------------------------------------------------------------------------------------------------------------------------------------------------------------------------------------------------------------------------------



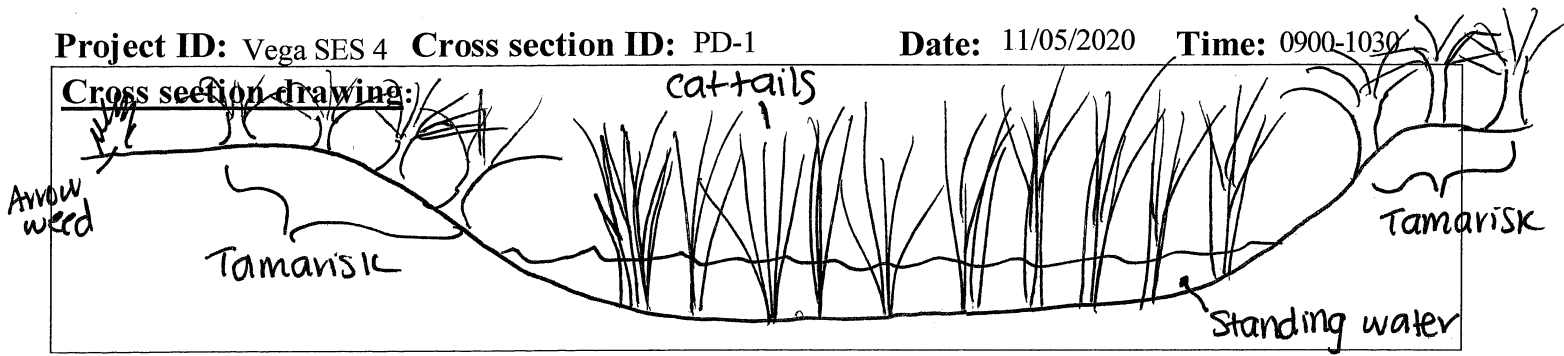
- Procedure for identifying and characterizing the floodplain units to assist in identifying the OHWM:**
1. Walk the channel and floodplain within the study area to get an impression of the geomorphology and vegetation present at the site.
 2. Select a representative cross section across the channel. Draw the cross section and label the floodplain units.
 3. Determine a point on the cross section that is characteristic of one of the hydrogeomorphic floodplain units.
 - a) Record the floodplain unit and GPS position.
 - b) Describe the sediment texture (using the Wentworth class size) and the vegetation characteristics of the floodplain unit.
 - c) Identify any indicators present at the location.
 4. Repeat for other points in different hydrogeomorphic floodplains across the cross section.
 5. Identify the OHWM and record the indicators. Record the OHWM position via:

<input type="checkbox"/> Mapping on aerial photograph	<input checked="" type="checkbox"/> GPS
<input type="checkbox"/> Digitized on computer	<input type="checkbox"/> Other:

Project ID: Vega SES 4 Cross section ID: PD-1

Date: 11/05/2020

Time: 0900-1030



OHWM

GPS point: 32.680595, -115.318096

Indicators:

- Change in average sediment texture
- Change in vegetation species
- Change in vegetation cover
- Break in bank slope
- Other: Natural line
- Other: _____

Comments:

Emergent wetland present within bed of drainage, and standing water present. Vegetation included cattail and tamarisk.

Floodplain unit: Low-Flow Channel Active Floodplain Low Terrace

GPS point: 32.680595, -115.318096

Characteristics of the floodplain unit:

Average sediment texture: Coarse silt

Total veg cover: 70 % Tree: 5 % Shrub: 65 % Herb: 0 %

Community successional stage:

- NA
- Early (herbaceous & seedlings)
- Mid (herbaceous, shrubs, saplings)
- Late (herbaceous, shrubs, mature trees)

Indicators:

- Mudcracks
- Ripples
- Drift and/or debris
- Presence of bed and bank
- Benches
- Soil development
- Surface relief
- Other: _____
- Other: _____
- Other: _____

Comments:

Standing water present; one drainage directly adjacent to the east.

Arid West Ephemeral and Intermittent Streams OHW M Datasheet

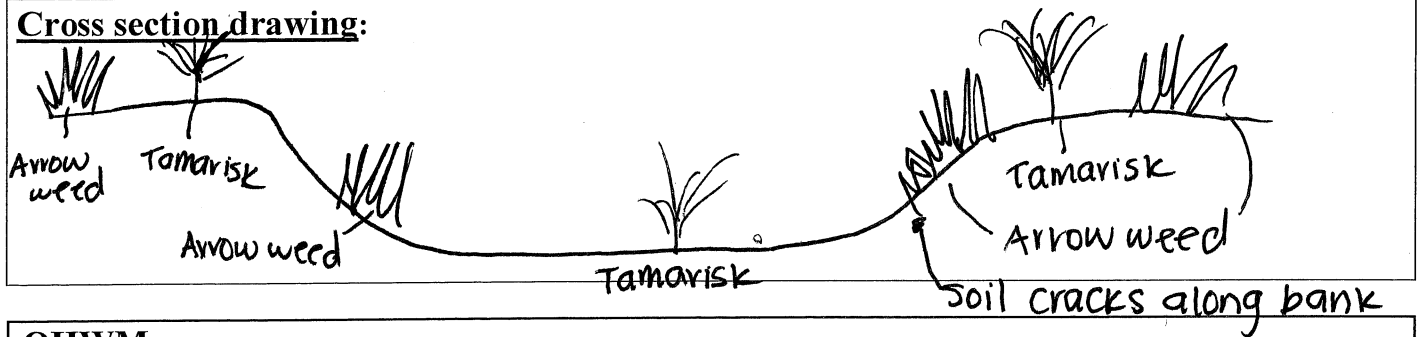
Project: Vega SES 4 Project Number: 2020-142 Stream: ED-1 Investigator(s): C. Torres, J. Kendrick	Date: 11/05/2020 Town: Holtville Photo begin file#: Time: 0900-1030 State: CA Photo end file#:
Y <input checked="" type="checkbox"/> / N <input type="checkbox"/> Do normal circumstances exist on the site? Y <input type="checkbox"/> / N <input checked="" type="checkbox"/> Is the site significantly disturbed?	Location Details: South of Salton Sea, directly south of All-American Canal and north of US -Mexico border Projection: Datum: NAD83 Coordinates:
Potential anthropogenic influences on the channel system: Site priorly used for agriculture and has been previously disturbed/alterd. Runoff from adjacent agricultural land collects and is concentrated in the Study Area. Manmade berms line the drainages. Drainage system within a palustrine wetland in western portion of site.	
Brief site description: The Study Area is downslope of the All-American Canal, which brings water from the Colorado River and likely feeds into the site. Runoff generally flows south from the direction of the All-American Canal and toward the U.S.-Mexico border	
Checklist of resources (if available): <input checked="" type="checkbox"/> Aerial photography Dates: 1953, 1996-2016 (historic aerials); 11/2020 (sUAS imagery) <input checked="" type="checkbox"/> Topographic maps <input type="checkbox"/> Geologic maps <input checked="" type="checkbox"/> Vegetation maps <input checked="" type="checkbox"/> Soils maps <input type="checkbox"/> Rainfall/precipitation maps <input type="checkbox"/> Existing delineation(s) for site <input checked="" type="checkbox"/> Global positioning system (GPS) <input type="checkbox"/> Other studies <input type="checkbox"/> Stream gage data Gage number: Period of record: <input type="checkbox"/> History of recent effective discharges <input type="checkbox"/> Results of flood frequency analysis <input type="checkbox"/> Most recent shift-adjusted rating <input type="checkbox"/> Gage heights for 2-, 5-, 10-, and 25-year events and the most recent event exceeding a 5-year event	
Hydrogeomorphic Floodplain Units 	
Procedure for identifying and characterizing the floodplain units to assist in identifying the OHWM: 1. Walk the channel and floodplain within the study area to get an impression of the geomorphology and vegetation present at the site. 2. Select a representative cross section across the channel. Draw the cross section and label the floodplain units. 3. Determine a point on the cross section that is characteristic of one of the hydrogeomorphic floodplain units. a) Record the floodplain unit and GPS position. b) Describe the sediment texture (using the Wentworth class size) and the vegetation characteristics of the floodplain unit. c) Identify any indicators present at the location. 4. Repeat for other points in different hydrogeomorphic floodplain units across the cross section. 5. Identify the OHWM and record the indicators. Record the OHWM position via: <input type="checkbox"/> Mapping on aerial photograph <input checked="" type="checkbox"/> GPS <input type="checkbox"/> Digitized on computer <input type="checkbox"/> Other:	

Project ID: Vega SES 4 Cross section ID: ED-1

Date: 11/05/2020

Time: 0900-1030

Cross section drawing:



OHW

GPS point: 32.680267, -115.317448

Indicators:

- Change in average sediment texture
- Change in vegetation species
- Change in vegetation cover
- Break in bank slope
- Other: _____
- Other: _____

Comments:

Vegetated channel adjacent to a perennial drainage (with emergent wetland in the bed of the channel) to the west and one ephemeral drainage to the east. Vegetation within channel consists of arrow weed and tamarisk. Man-made berms line the channel.

Floodplain unit: Low-Flow Channel Active Floodplain Low Terrace

GPS point: 32.680267, -115.317448

Characteristics of the floodplain unit:

Average sediment texture: Medium sand/sand

Total veg cover: 55 % Tree: 20 % Shrub: 35 % Herb: 0 %

Community successional stage:

- NA
- Early (herbaceous & seedlings)
- Mid (herbaceous, shrubs, saplings)
- Late (herbaceous, shrubs, mature trees)

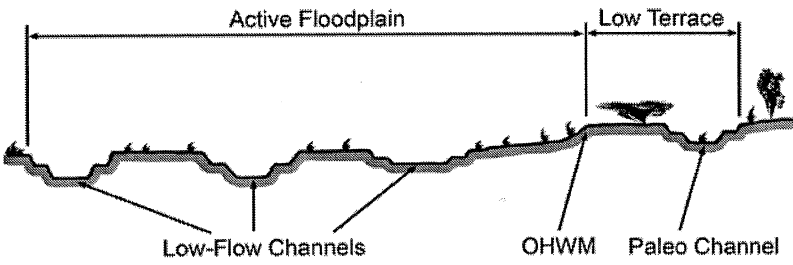
Indicators:

- Mudcracks
- Ripples
- Drift and/or debris
- Presence of bed and bank
- Benches
- Soil development
- Surface relief
- Other: _____
- Other: _____
- Other: _____

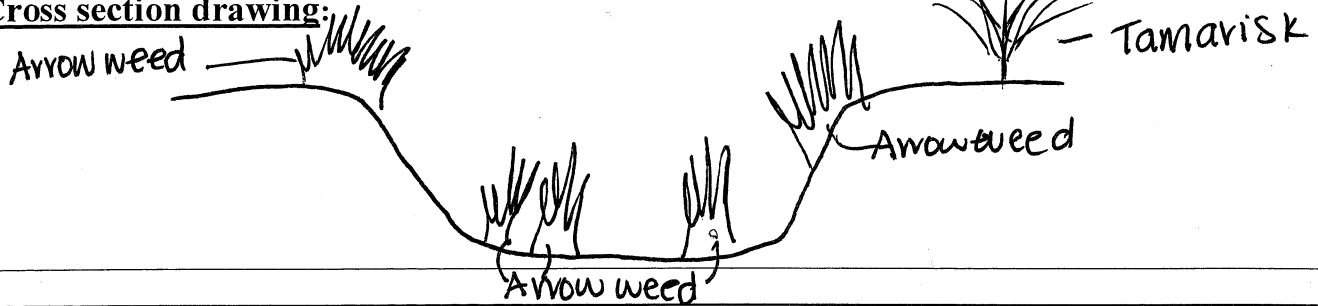
Comments:

Salt crust present, but likely from adjacent agricultural run-off. Water seems to flood over bank of channel to adjacent channels/wetland.

Arid West Ephemeral and Intermittent Streams OHWM Datasheet

Project: Vega SES 4 Project Number: 2020-142 Stream: ED-2 Investigator(s): C. Torres, J. Kendrick	Date: 11/5/2020 Town: Holtville Photo begin file#:	Time: 0900-1030 State: CA Photo end file#:				
Y <input checked="" type="checkbox"/> / N <input type="checkbox"/> Do normal circumstances exist on the site?	Location Details: South of Salton Sea, directly south of All-American Canal and adjacent to US -Mexico border					
Y <input type="checkbox"/> / N <input checked="" type="checkbox"/> Is the site significantly disturbed?	Projection: Datum: NAD83 Coordinates:					
Potential anthropogenic influences on the channel system: Site priorly used for agriculture and has been previously disturbed/alterd. Runoff from adjacent agricultural land collects and is concentrated in the Study Area. Manmade berms line the drainages. Drainage system within a palustrine wetland in western portion of site.						
Brief site description: The Study Area is downslope of the All-American Canal, which brings water from the Colorado River and likely feeds into the site. Runoff generally flows south from the direction of the All-American Canal and toward the U.S.-Mexico border						
Checklist of resources (if available): <table style="width: 100%; border: none;"> <tr> <td style="width: 50%; vertical-align: top;"> <input checked="" type="checkbox"/> Aerial photography Dates: 1953, 1996-2016 (historic aerials); 11/2020 (sUAS imagery) <input checked="" type="checkbox"/> Topographic maps <input type="checkbox"/> Geologic maps <input checked="" type="checkbox"/> Vegetation maps <input checked="" type="checkbox"/> Soils maps <input type="checkbox"/> Rainfall/precipitation maps <input type="checkbox"/> Existing delineation(s) for site <input checked="" type="checkbox"/> Global positioning system (GPS) <input type="checkbox"/> Other studies </td> <td style="width: 50%; vertical-align: top;"> <input type="checkbox"/> Stream gage data Gage number: Period of record: <input type="checkbox"/> History of recent effective discharges <input type="checkbox"/> Results of flood frequency analysis <input type="checkbox"/> Most recent shift-adjusted rating <input type="checkbox"/> Gage heights for 2-, 5-, 10-, and 25-year events and the most recent event exceeding a 5-year event </td> </tr> </table>			<input checked="" type="checkbox"/> Aerial photography Dates: 1953, 1996-2016 (historic aerials); 11/2020 (sUAS imagery) <input checked="" type="checkbox"/> Topographic maps <input type="checkbox"/> Geologic maps <input checked="" type="checkbox"/> Vegetation maps <input checked="" type="checkbox"/> Soils maps <input type="checkbox"/> Rainfall/precipitation maps <input type="checkbox"/> Existing delineation(s) for site <input checked="" type="checkbox"/> Global positioning system (GPS) <input type="checkbox"/> Other studies	<input type="checkbox"/> Stream gage data Gage number: Period of record: <input type="checkbox"/> History of recent effective discharges <input type="checkbox"/> Results of flood frequency analysis <input type="checkbox"/> Most recent shift-adjusted rating <input type="checkbox"/> Gage heights for 2-, 5-, 10-, and 25-year events and the most recent event exceeding a 5-year event		
<input checked="" type="checkbox"/> Aerial photography Dates: 1953, 1996-2016 (historic aerials); 11/2020 (sUAS imagery) <input checked="" type="checkbox"/> Topographic maps <input type="checkbox"/> Geologic maps <input checked="" type="checkbox"/> Vegetation maps <input checked="" type="checkbox"/> Soils maps <input type="checkbox"/> Rainfall/precipitation maps <input type="checkbox"/> Existing delineation(s) for site <input checked="" type="checkbox"/> Global positioning system (GPS) <input type="checkbox"/> Other studies	<input type="checkbox"/> Stream gage data Gage number: Period of record: <input type="checkbox"/> History of recent effective discharges <input type="checkbox"/> Results of flood frequency analysis <input type="checkbox"/> Most recent shift-adjusted rating <input type="checkbox"/> Gage heights for 2-, 5-, 10-, and 25-year events and the most recent event exceeding a 5-year event					
Hydrogeomorphic Floodplain Units 						
Procedure for identifying and characterizing the floodplain units to assist in identifying the OHWM: <ol style="list-style-type: none"> 1. Walk the channel and floodplain within the study area to get an impression of the geomorphology and vegetation present at the site. 2. Select a representative cross section across the channel. Draw the cross section and label the floodplain units. 3. Determine a point on the cross section that is characteristic of one of the hydrogeomorphic floodplain units. <ol style="list-style-type: none"> a) Record the floodplain unit and GPS position. b) Describe the sediment texture (using the Wentworth class size) and the vegetation characteristics of the floodplain unit. c) Identify any indicators present at the location. 4. Repeat for other points in different hydrogeomorphic floodplain units across the cross section. 5. Identify the OHWM and record the indicators. Record the OHWM position via: <table style="width: 100%; border: none; margin-top: 5px;"> <tr> <td style="width: 50%;"><input type="checkbox"/> Mapping on aerial photograph</td> <td style="width: 50%;"><input checked="" type="checkbox"/> GPS</td> </tr> <tr> <td><input type="checkbox"/> Digitized on computer</td> <td><input type="checkbox"/> Other:</td> </tr> </table> 			<input type="checkbox"/> Mapping on aerial photograph	<input checked="" type="checkbox"/> GPS	<input type="checkbox"/> Digitized on computer	<input type="checkbox"/> Other:
<input type="checkbox"/> Mapping on aerial photograph	<input checked="" type="checkbox"/> GPS					
<input type="checkbox"/> Digitized on computer	<input type="checkbox"/> Other:					

Cross section drawing:



OHWM

GPS point: 32.680418, -115.317431

Indicators:

- Change in average sediment texture
- Change in vegetation species
- Change in vegetation cover
- Break in bank slope
- Other: _____
- Other: _____

Comments:

Vegetated channel adjacent to one channel to the east and one channel to the west. Vegetation consists of tamarisk and arrow weed. Man-made berms line the channel.

Floodplain unit: Low-Flow Channel Active Floodplain Low Terrace

GPS point: 32.680418, -115.317431

Characteristics of the floodplain unit:

Average sediment texture: Medium sand/sand

Total veg cover: 70 % Tree: 10 % Shrub: 60 % Herb: 0 %

Community successional stage:

- NA
- Early (herbaceous & seedlings)
- Mid (herbaceous, shrubs, saplings)
- Late (herbaceous, shrubs, mature trees)

Indicators:

- Mudcracks
- Ripples
- Drift and/or debris
- Presence of bed and bank
- Benches
- Soil development
- Surface relief
- Other: _____
- Other: _____
- Other: _____

Comments:

Salt crust present, but likely from adjacent agricultural run-off. Water seems to flood over bank of channel to adjacent channels/wetland.

Arid West Ephemeral and Intermittent Streams OHW M Datasheet

Project: Vega SES 4 Project Number: 2020-142 Stream: ED-3 Investigator(s): C. Torres, J. Kendrick	Date: 11/05/2020 Town: Holtville Photo begin file#:	Time: 0900-1030 State: CA Photo end file#:
----------------------------------------------------------------------------------------------------------------------------------------	--------------------------------------------------------------------------------	-----------------------------------------------------------------------

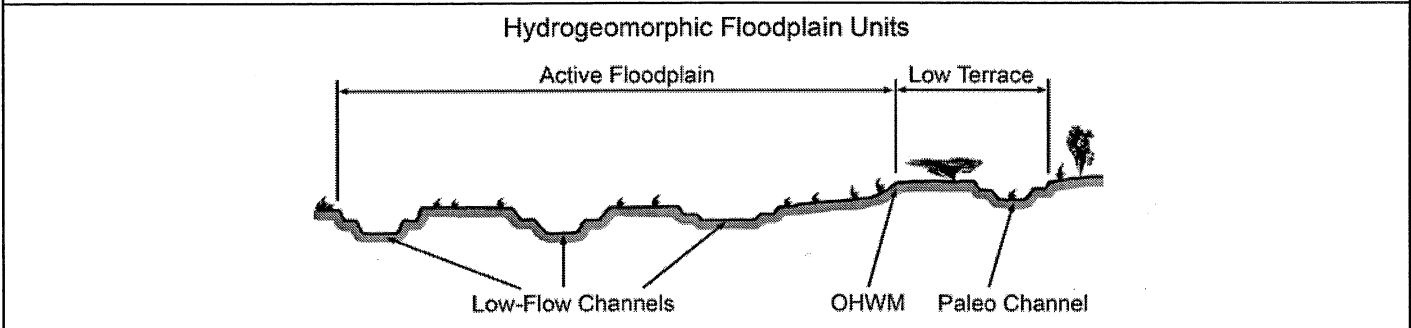
Y <input checked="" type="checkbox"/> / N <input type="checkbox"/> Do normal circumstances exist on the site? Y <input type="checkbox"/> / N <input checked="" type="checkbox"/> Is the site significantly disturbed?	Location Details: South of Salton Sea, directly south of All-American Canal and north of US -Mexico border Projection: Datum: NAD83 Coordinates:
------------------------------------------------------------------------------------------------------------------------------------------------------------------------------------------------------------------------------	---------------------------------------------------------------------------------------------------------------------------------------------------------------------------------------------------------------------------

Potential anthropogenic influences on the channel system:
 Site priorly used for agriculture and has been previously disturbed/alterd. Runoff from adjacent agricultural land collects and is concentrated in the Study Area. Manmade berms line the drainages. Drainage system within a palustrine wetland in western portion of site.

Brief site description:
 The Study Area is downslope of the All-American Canal, which brings water from the Colorado River and likely feeds into the site. Runoff generally flows south from the direction of the All-American Canal and toward the U.S.-Mexico border

Checklist of resources (if available):

<input checked="" type="checkbox"/> Aerial photography Dates: 1953, 1996-2016 (historic aeriels); 11/2020 (sUAS imagery) <input checked="" type="checkbox"/> Topographic maps <input type="checkbox"/> Geologic maps <input checked="" type="checkbox"/> Vegetation maps <input checked="" type="checkbox"/> Soils maps <input type="checkbox"/> Rainfall/precipitation maps <input type="checkbox"/> Existing delineation(s) for site <input checked="" type="checkbox"/> Global positioning system (GPS) <input type="checkbox"/> Other studies	<input type="checkbox"/> Stream gage data Gage number: Period of record: <input type="checkbox"/> History of recent effective discharges <input type="checkbox"/> Results of flood frequency analysis <input type="checkbox"/> Most recent shift-adjusted rating <input type="checkbox"/> Gage heights for 2-, 5-, 10-, and 25-year events and the most recent event exceeding a 5-year event
------------------------------------------------------------------------------------------------------------------------------------------------------------------------------------------------------------------------------------------------------------------------------------------------------------------------------------------------------------------------------------------------------------------------------------------------------------------------------------------------------------------------------------------------------------------------------	-----------------------------------------------------------------------------------------------------------------------------------------------------------------------------------------------------------------------------------------------------------------------------------------------------------------------------------------------------------------------------------------------------------------

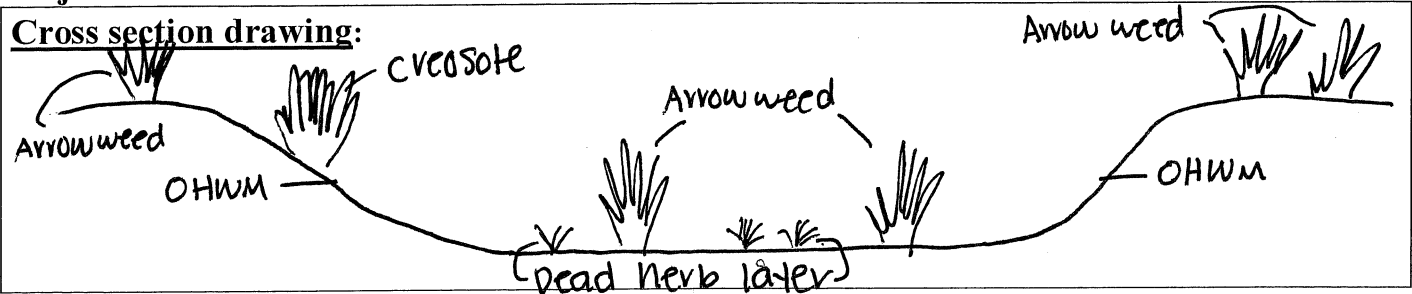


Procedure for identifying and characterizing the floodplain units to assist in identifying the OHWM:

1. Walk the channel and floodplain within the study area to get an impression of the geomorphology and vegetation present at the site.
2. Select a representative cross section across the channel. Draw the cross section and label the floodplain units.
3. Determine a point on the cross section that is characteristic of one of the hydrogeomorphic floodplain units.
 - a) Record the floodplain unit and GPS position.
 - b) Describe the sediment texture (using the Wentworth class size) and the vegetation characteristics of the floodplain unit.
 - c) Identify any indicators present at the location.
4. Repeat for other points in different hydrogeomorphic floodplain units across the cross section.
5. Identify the OHWM and record the indicators. Record the OHWM position via:

<input type="checkbox"/> Mapping on aerial photograph	<input checked="" type="checkbox"/> GPS
<input type="checkbox"/> Digitized on computer	<input type="checkbox"/> Other:

Cross section drawing:



OHWM

GPS point: 32.680503, -115.317320

Indicators:

- | | |
|----------------------------------------------------------------|---------------------------------------------------------|
| <input type="checkbox"/> Change in average sediment texture | <input checked="" type="checkbox"/> Break in bank slope |
| <input type="checkbox"/> Change in vegetation species | <input type="checkbox"/> Other: _____ |
| <input checked="" type="checkbox"/> Change in vegetation cover | <input type="checkbox"/> Other: _____ |

Comments:

Vegetated channel adjacent to another channel to the west. Vegetation consists of arrow weed within the channel. OHWM was slight.

Floodplain unit: Low-Flow Channel Active Floodplain Low Terrace

GPS point: 32.680503, -115.317320

Characteristics of the floodplain unit:

Average sediment texture: Medium sand/sand

Total veg cover: 35 % Tree: 0 % Shrub: 18 % Herb: 17 %

Community successional stage:

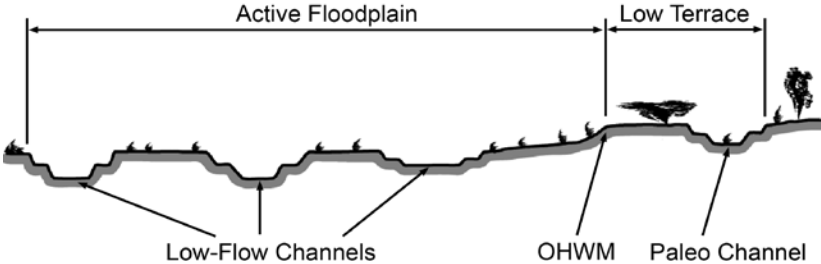
- | | |
|---------------------------------------------------------|-----------------------------------------------------------------------------|
| <input type="checkbox"/> NA | <input type="checkbox"/> Mid (herbaceous, shrubs, saplings) |
| <input type="checkbox"/> Early (herbaceous & seedlings) | <input checked="" type="checkbox"/> Late (herbaceous, shrubs, mature trees) |

Indicators:

- | | |
|--------------------------------------------------------------|------------------------------------------------------------------------------|
| <input type="checkbox"/> Mudcracks | <input type="checkbox"/> Soil development |
| <input type="checkbox"/> Ripples | <input type="checkbox"/> Surface relief |
| <input type="checkbox"/> Drift and/or debris | <input checked="" type="checkbox"/> Other: <u>Change in vegetation cover</u> |
| <input checked="" type="checkbox"/> Presence of bed and bank | <input type="checkbox"/> Other: _____ |
| <input type="checkbox"/> Benches | <input type="checkbox"/> Other: _____ |

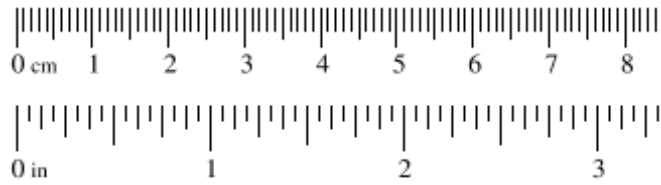
Comments:

Arid West Ephemeral and Intermittent Streams OHWM Datasheet

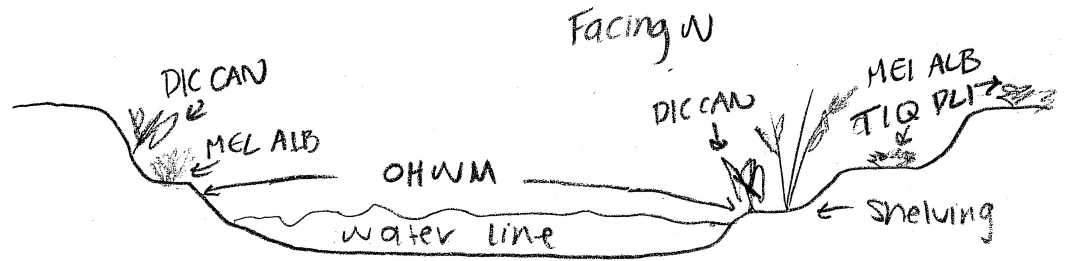
Project: Vega SES 4 Project Number: 2020-142 Stream: Offline Storage canal for All-American Canal Investigator(s): C. Torres, C. Garcia	Date: 4/12/2022 Town: Holtville Photo begin file#:	Time: 0900 State: CA Photo end file#:				
Y <input checked="" type="checkbox"/> / N <input type="checkbox"/> Do normal circumstances exist on the site? Y <input type="checkbox"/> / N <input checked="" type="checkbox"/> Is the site significantly disturbed?	Location Details: Offline storage canal, serving as a tributary to the All-American Canal to the south. Projection: _____ Datum: _____ Coordinates: _____					
Potential anthropogenic influences on the channel system: Trash and dumping. Canal is managed by IID, including flow.						
Brief site description: Natural-bottomed storage canal serving as a tributary to the All-American Canal located directly south. Both canals run parallel to the U.S./Mexico border. Cross-section taken at the Gordon Well Road bridge crossing.						
Checklist of resources (if available): <table style="width: 100%; border: none;"> <tr> <td style="width: 50%; vertical-align: top;"> <input checked="" type="checkbox"/> Aerial photography Dates: 1953-2019 <input checked="" type="checkbox"/> Topographic maps <input type="checkbox"/> Geologic maps <input type="checkbox"/> Vegetation maps <input checked="" type="checkbox"/> Soils maps <input checked="" type="checkbox"/> Rainfall/precipitation maps <input type="checkbox"/> Existing delineation(s) for site <input checked="" type="checkbox"/> Global positioning system (GPS) <input type="checkbox"/> Other studies </td> <td style="width: 50%; vertical-align: top;"> <input type="checkbox"/> Stream gage data Gage number: _____ Period of record: _____ <input type="checkbox"/> History of recent effective discharges <input type="checkbox"/> Results of flood frequency analysis <input type="checkbox"/> Most recent shift-adjusted rating <input type="checkbox"/> Gage heights for 2-, 5-, 10-, and 25-year events and the most recent event exceeding a 5-year event </td> </tr> </table>			<input checked="" type="checkbox"/> Aerial photography Dates: 1953-2019 <input checked="" type="checkbox"/> Topographic maps <input type="checkbox"/> Geologic maps <input type="checkbox"/> Vegetation maps <input checked="" type="checkbox"/> Soils maps <input checked="" type="checkbox"/> Rainfall/precipitation maps <input type="checkbox"/> Existing delineation(s) for site <input checked="" type="checkbox"/> Global positioning system (GPS) <input type="checkbox"/> Other studies	<input type="checkbox"/> Stream gage data Gage number: _____ Period of record: _____ <input type="checkbox"/> History of recent effective discharges <input type="checkbox"/> Results of flood frequency analysis <input type="checkbox"/> Most recent shift-adjusted rating <input type="checkbox"/> Gage heights for 2-, 5-, 10-, and 25-year events and the most recent event exceeding a 5-year event		
<input checked="" type="checkbox"/> Aerial photography Dates: 1953-2019 <input checked="" type="checkbox"/> Topographic maps <input type="checkbox"/> Geologic maps <input type="checkbox"/> Vegetation maps <input checked="" type="checkbox"/> Soils maps <input checked="" type="checkbox"/> Rainfall/precipitation maps <input type="checkbox"/> Existing delineation(s) for site <input checked="" type="checkbox"/> Global positioning system (GPS) <input type="checkbox"/> Other studies	<input type="checkbox"/> Stream gage data Gage number: _____ Period of record: _____ <input type="checkbox"/> History of recent effective discharges <input type="checkbox"/> Results of flood frequency analysis <input type="checkbox"/> Most recent shift-adjusted rating <input type="checkbox"/> Gage heights for 2-, 5-, 10-, and 25-year events and the most recent event exceeding a 5-year event					
Hydrogeomorphic Floodplain Units 						
Procedure for identifying and characterizing the floodplain units to assist in identifying the OHWM: <ol style="list-style-type: none"> 1. Walk the channel and floodplain within the study area to get an impression of the geomorphology and vegetation present at the site. 2. Select a representative cross section across the channel. Draw the cross section and label the floodplain units. 3. Determine a point on the cross section that is characteristic of one of the hydrogeomorphic floodplain units. <ol style="list-style-type: none"> a) Record the floodplain unit and GPS position. b) Describe the sediment texture (using the Wentworth class size) and the vegetation characteristics of the floodplain unit. c) Identify any indicators present at the location. 4. Repeat for other points in different hydrogeomorphic floodplain units across the cross section. 5. Identify the OHWM and record the indicators. Record the OHWM position via: <table style="width: 100%; border: none; margin-top: 5px;"> <tr> <td style="width: 50%;"><input type="checkbox"/> Mapping on aerial photograph</td> <td style="width: 50%;"><input checked="" type="checkbox"/> GPS</td> </tr> <tr> <td><input type="checkbox"/> Digitized on computer</td> <td><input type="checkbox"/> Other:</td> </tr> </table> 			<input type="checkbox"/> Mapping on aerial photograph	<input checked="" type="checkbox"/> GPS	<input type="checkbox"/> Digitized on computer	<input type="checkbox"/> Other:
<input type="checkbox"/> Mapping on aerial photograph	<input checked="" type="checkbox"/> GPS					
<input type="checkbox"/> Digitized on computer	<input type="checkbox"/> Other:					

Wentworth Size Classes

Inches (in)	Millimeters (mm)	Wentworth size class
10.08	256	Boulder
2.56	64	Cobble
0.157	4	Pebble
0.079	2.00	Granule
0.039	1.00	Very coarse sand
0.020	0.50	Coarse sand
1/2 0.0098	0.25	Medium sand
1/4 0.005	0.125	Fine sand
1/8 0.0025	0.0625	Very fine sand
1/16 0.0012	0.031	Coarse silt
1/32 0.00061	0.0156	Medium silt
1/64 0.00031	0.0078	Fine silt
1/128 0.00015	0.0039	Very fine silt
		Clay



Cross section drawing:



OHWM

GPS point: 32.705570, -114.957454

Indicators:

- Change in average sediment texture
- Change in vegetation species
- Change in vegetation cover
- Break in bank slope
- Other: see comments
- Other: _____

Comments:

Additional OHWM indicators: shelving, natural line, scour, wracking, drift/debris, benches, ripples.
 OHWM width= 150'
 B2B width= 200'

Floodplain unit:

- Low-Flow Channel
- Active Floodplain
- Low Terrace

GPS point: 32.705570, -114.957454

Characteristics of the floodplain unit:

Average sediment texture: Fine sand
 Total veg cover: 3 % Tree: _____% Shrub: 1 % Herb: 2 %
 Community successional stage:

- NA
- Early (herbaceous & seedlings)
- Mid (herbaceous, shrubs, saplings)
- Late (herbaceous, shrubs, mature trees)

Indicators:

- Mudcracks
- Ripples
- Drift and/or debris
- Presence of bed and bank
- Benches
- Soil development
- Surface relief
- Other: _____
- Other: _____
- Other: _____

Comments:

WETLAND DETERMINATION DATA FORM – Arid West Region

Project/Site: Vega SES 4 City/County: Holtville/ Imperial County Sampling Date: 11/4/2020
 Applicant/Owner: zGlobal, Inc. State: CA Sampling Point: 1
 Investigator(s): C. Congedo, C. Torres Section, Township, Range: S10, T17S, R16E
 Landform (hillslope, terrace, etc.): Depression Local relief (concave, convex, none): Concave Slope (%): 10
 Subregion (LRR): D Lat: 32.6818662 Long: -115.3161832 Datum: NAD83
 Soil Map Unit Name: Rositas sand, 2 to 5 percent slopes NWI classification: N/A

Are climatic / hydrologic conditions on the site typical for this time of year? Yes No (If no, explain in Remarks.)
 Are Vegetation , Soil , or Hydrology significantly disturbed? Are "Normal Circumstances" present? Yes No
 Are Vegetation , Soil , or Hydrology naturally problematic? (If needed, explain any answers in Remarks.)

SUMMARY OF FINDINGS – Attach site map showing sampling point locations, transects, important features, etc.

Hydrophytic Vegetation Present? Yes <input checked="" type="checkbox"/> No <input type="checkbox"/> Hydric Soil Present? Yes <input checked="" type="checkbox"/> No <input type="checkbox"/> Wetland Hydrology Present? Yes <input checked="" type="checkbox"/> No <input type="checkbox"/>	Is the Sampled Area within a Wetland? Yes <input checked="" type="checkbox"/> No <input type="checkbox"/>
Remarks: Point taken within tamarisk thickets, downslope (south) of a hard-packed dirt road that runs parallel to the All-American Canal.	

VEGETATION – Use scientific names of plants.

Tree Stratum (Plot size: <u>30'</u>)	Absolute % Cover	Dominant Species?	Indicator Status	
1. <u>Tamarix sp.</u>	<u>5</u>		<u>FAC</u>	Dominance Test worksheet: Number of Dominant Species That Are OBL, FACW, or FAC: <u>1</u> (A) Total Number of Dominant Species Across All Strata: <u>1</u> (B) Percent of Dominant Species That Are OBL, FACW, or FAC: <u>100</u> (A/B)
2. _____				
3. _____				
4. _____				
	<u>5</u>	= Total Cover		
Sapling/Shrub Stratum (Plot size: <u>30'</u>)	Absolute % Cover	Dominant Species?	Indicator Status	
1. <u>Pluchea sericea</u>	<u>20</u>	<u>x</u>	<u>FACW</u>	Prevalence Index worksheet: Total % Cover of: _____ Multiply by: _____ OBL species <u>0</u> x 1 = <u>0</u> FACW species <u>22</u> x 2 = <u>44</u> FAC species <u>5</u> x 3 = <u>15</u> FACU species <u>0</u> x 4 = <u>0</u> UPL species <u>0</u> x 5 = <u>0</u> Column Totals: <u>27</u> (A) <u>59</u> (B) Prevalence Index = B/A = <u>2.19</u>
2. <u>Baccharis salicina</u>	<u>2</u>		<u>FACW</u>	
3. _____				
4. _____				
5. _____				
	<u>22</u>	= Total Cover		
Herb Stratum (Plot size: _____)	Absolute % Cover	Dominant Species?	Indicator Status	
1. _____				Hydrophytic Vegetation Indicators: <input checked="" type="checkbox"/> Dominance Test is >50% <input checked="" type="checkbox"/> Prevalence Index is ≤3.0 ¹ <input type="checkbox"/> Morphological Adaptations ¹ (Provide supporting data in Remarks or on a separate sheet) <input type="checkbox"/> Problematic Hydrophytic Vegetation ¹ (Explain) ¹ Indicators of hydric soil and wetland hydrology must be present, unless disturbed or problematic.
2. _____				
3. _____				
4. _____				
5. _____				
6. _____				
7. _____				
8. _____				
	<u>0</u>	= Total Cover		
Woody Vine Stratum (Plot size: _____)	Absolute % Cover	Dominant Species?	Indicator Status	
1. _____				Hydrophytic Vegetation Present? Yes <input checked="" type="checkbox"/> No <input type="checkbox"/>
2. _____				
	<u>0</u>	= Total Cover		
% Bare Ground in Herb Stratum <u>73</u> % Cover of Biotic Crust _____				
Remarks:				

SOIL

Sampling Point: 1

Profile Description: (Describe to the depth needed to document the indicator or confirm the absence of indicators.)								
Depth (inches)	Matrix		Redox Features				Texture	Remarks
	Color (moist)	%	Color (moist)	%	Type ¹	Loc ²		
0-0.2	10YR 4/3	100					Loam	Organic material
0.2-2	10YR 5/4	100					Loam	Clayey layer
2-5	10YR 4/4	95	5YR 5/6	5	C	PL, M	Sandy loam	
5-13+	10YR 5/4	97	2.5YR 5/6	3	C	PL	Sand	
¹ Type: C=Concentration, D=Depletion, RM=Reduced Matrix, CS=Covered or Coated Sand Grains. ² Location: PL=Pore Lining, M=Matrix.								
Hydric Soil Indicators: (Applicable to all LRRs, unless otherwise noted.)						Indicators for Problematic Hydric Soils³:		
<input type="checkbox"/> Histosol (A1)			<input type="checkbox"/> Sandy Redox (S5)			<input type="checkbox"/> 1 cm Muck (A9) (LRR C)		
<input type="checkbox"/> Histic Epipedon (A2)			<input type="checkbox"/> Stripped Matrix (S6)			<input type="checkbox"/> 2 cm Muck (A10) (LRR B)		
<input type="checkbox"/> Black Histic (A3)			<input type="checkbox"/> Loamy Mucky Mineral (F1)			<input type="checkbox"/> Reduced Vertic (F18)		
<input type="checkbox"/> Hydrogen Sulfide (A4)			<input type="checkbox"/> Loamy Gleyed Matrix (F2)			<input type="checkbox"/> Red Parent Material (TF2)		
<input type="checkbox"/> Stratified Layers (A5) (LRR C)			<input type="checkbox"/> Depleted Matrix (F3)			<input type="checkbox"/> Other (Explain in Remarks)		
<input type="checkbox"/> 1 cm Muck (A9) (LRR D)			<input type="checkbox"/> Redox Dark Surface (F6)			³ Indicators of hydrophytic vegetation and wetland hydrology must be present, unless disturbed or problematic.		
<input type="checkbox"/> Depleted Below Dark Surface (A11)			<input type="checkbox"/> Depleted Dark Surface (F7)					
<input type="checkbox"/> Thick Dark Surface (A12)			<input checked="" type="checkbox"/> Redox Depressions (F8)					
<input type="checkbox"/> Sandy Mucky Mineral (S1)			<input type="checkbox"/> Vernal Pools (F9)					
<input type="checkbox"/> Sandy Gleyed Matrix (S4)								
Restrictive Layer (if present):						Hydric Soil Present? Yes <input checked="" type="checkbox"/> No <input type="checkbox"/>		
Type: _____								
Depth (inches): _____								
Remarks:								

HYDROLOGY

Wetland Hydrology Indicators:			
Primary Indicators (minimum of one required; check all that apply)		Secondary Indicators (2 or more required)	
<input type="checkbox"/> Surface Water (A1)	<input type="checkbox"/> Salt Crust (B11)	<input type="checkbox"/> Water Marks (B1) (Riverine)	
<input type="checkbox"/> High Water Table (A2)	<input type="checkbox"/> Biotic Crust (B12)	<input type="checkbox"/> Sediment Deposits (B2) (Riverine)	
<input checked="" type="checkbox"/> Saturation (A3)	<input type="checkbox"/> Aquatic Invertebrates (B13)	<input type="checkbox"/> Drift Deposits (B3) (Riverine)	
<input type="checkbox"/> Water Marks (B1) (Nonriverine)	<input type="checkbox"/> Hydrogen Sulfide Odor (C1)	<input type="checkbox"/> Drainage Patterns (B10)	
<input type="checkbox"/> Sediment Deposits (B2) (Nonriverine)	<input type="checkbox"/> Oxidized Rhizospheres along Living Roots (C3)	<input type="checkbox"/> Dry-Season Water Table (C2)	
<input type="checkbox"/> Drift Deposits (B3) (Nonriverine)	<input type="checkbox"/> Presence of Reduced Iron (C4)	<input type="checkbox"/> Crayfish Burrows (C8)	
<input checked="" type="checkbox"/> Surface Soil Cracks (B6)	<input type="checkbox"/> Recent Iron Reduction in Tilled Soils (C6)	<input type="checkbox"/> Saturation Visible on Aerial Imagery (C9)	
<input type="checkbox"/> Inundation Visible on Aerial Imagery (B7)	<input type="checkbox"/> Thin Muck Surface (C7)	<input type="checkbox"/> Shallow Aquitard (D3)	
<input type="checkbox"/> Water-Stained Leaves (B9)	<input type="checkbox"/> Other (Explain in Remarks)	<input type="checkbox"/> FAC-Neutral Test (D5)	
Field Observations:		Wetland Hydrology Present? Yes <input checked="" type="checkbox"/> No <input type="checkbox"/>	
Surface Water Present?	Yes <input type="checkbox"/> No <input checked="" type="checkbox"/> Depth (inches): _____		
Water Table Present?	Yes <input type="checkbox"/> No <input checked="" type="checkbox"/> Depth (inches): _____		
Saturation Present? (includes capillary fringe)	Yes <input checked="" type="checkbox"/> No <input type="checkbox"/> Depth (inches): <u>0</u>		
Describe Recorded Data (stream gauge, monitoring well, aerial photos, previous inspections), if available:			
Remarks:			
Salt crust, but could be from agricultural run-off.			

WETLAND DETERMINATION DATA FORM – Arid West Region

Project/Site: Vega SES 4 City/County: Holtville/ Imperial County Sampling Date: 11/4/2020
 Applicant/Owner: zGlobal, Inc. State: CA Sampling Point: 2
 Investigator(s): C. Congedo, C. Torres Section, Township, Range: S10, T17S, R16E
 Landform (hillslope, terrace, etc.): Channel Local relief (concave, convex, none): Concave Slope (%): 25
 Subregion (LRR): D Lat: 32.680633 Long: -115.318002 Datum: NAD83
 Soil Map Unit Name: Vint loamy very fine sand, wet NWI classification: N/A

Are climatic / hydrologic conditions on the site typical for this time of year? Yes No (If no, explain in Remarks.)
 Are Vegetation , Soil , or Hydrology significantly disturbed? Are "Normal Circumstances" present? Yes No
 Are Vegetation , Soil , or Hydrology naturally problematic? (If needed, explain any answers in Remarks.)

SUMMARY OF FINDINGS – Attach site map showing sampling point locations, transects, important features, etc.

Hydrophytic Vegetation Present? Yes <input checked="" type="checkbox"/> No <input type="checkbox"/> Hydric Soil Present? Yes <input checked="" type="checkbox"/> No <input type="checkbox"/> Wetland Hydrology Present? Yes <input checked="" type="checkbox"/> No <input type="checkbox"/>	Is the Sampled Area within a Wetland? Yes <input checked="" type="checkbox"/> No <input type="checkbox"/>
Remarks: Point taken within emergent wetland in the bed of a drainage.	

VEGETATION – Use scientific names of plants.

Tree Stratum (Plot size: <u>10'</u>)	Absolute % Cover	Dominant Species?	Indicator Status	
1. <u>Tamarix sp.</u>	<u>5</u>		<u>FAC</u>	Dominance Test worksheet: Number of Dominant Species That Are OBL, FACW, or FAC: <u>1</u> (A) Total Number of Dominant Species Across All Strata: <u>1</u> (B) Percent of Dominant Species That Are OBL, FACW, or FAC: <u>100</u> (A/B)
2. _____				
3. _____				
4. _____				
	<u>5</u>	<u>= Total Cover</u>		Prevalence Index worksheet: Total % Cover of: _____ Multiply by: _____ OBL species <u>65</u> x 1 = <u>65</u> FACW species <u>0</u> x 2 = <u>0</u> FAC species <u>5</u> x 3 = <u>15</u> FACU species <u>0</u> x 4 = <u>0</u> UPL species <u>0</u> x 5 = <u>0</u> Column Totals: <u>70</u> (A) <u>80</u> (B) Prevalence Index = B/A = <u>1.14</u>
<u>Sapling/Shrub Stratum (Plot size: <u>10'</u>)</u>				
1. <u>Typha sp.</u>	<u>65</u>	<u>x</u>	<u>OBL</u>	
2. _____				
3. _____				
4. _____				
5. _____				
	<u>65</u>	<u>= Total Cover</u>		
<u>Herb Stratum (Plot size: _____)</u>				Hydrophytic Vegetation Indicators: <input checked="" type="checkbox"/> Dominance Test is >50% <input checked="" type="checkbox"/> Prevalence Index is ≤3.0 ¹ <input type="checkbox"/> Morphological Adaptations ¹ (Provide supporting data in Remarks or on a separate sheet) <input type="checkbox"/> Problematic Hydrophytic Vegetation ¹ (Explain) ¹ Indicators of hydric soil and wetland hydrology must be present, unless disturbed or problematic. Hydrophytic Vegetation Present? Yes <input checked="" type="checkbox"/> No <input type="checkbox"/>
1. _____				
2. _____				
3. _____				
4. _____				
5. _____				
6. _____				
7. _____				
8. _____				
	<u>0</u>	<u>= Total Cover</u>		
<u>Woody Vine Stratum (Plot size: _____)</u>				
1. _____				
2. _____				
	<u>0</u>	<u>= Total Cover</u>		
% Bare Ground in Herb Stratum <u>35</u> % Cover of Biotic Crust _____				

Remarks:

SOIL

Sampling Point: 2

Profile Description: (Describe to the depth needed to document the indicator or confirm the absence of indicators.)

Depth (inches)	Matrix		Redox Features				Texture	Remarks
	Color (moist)	%	Color (moist)	%	Type ¹	Loc ²		
0-1	10YR 2/2	100						Organic material- muck (greasy)
1-6	10YR 6/2	92	Gley 1, 2.5/N	3	C	M	Loam	Iron manganese masses
1-6			5YR 5/8	5	C	PL, M		
6-13+	Gley 1, 5/N	70					Silty clay _h	
	Gley 1, 4/N	30					Silty clay _h	

¹Type: C=Concentration, D=Depletion, RM=Reduced Matrix, CS=Covered or Coated Sand Grains. ²Location: PL=Pore Lining, M=Matrix.

Hydric Soil Indicators: (Applicable to all LRRs, unless otherwise noted.)

- Histosol (A1)
- Histic Epipedon (A2)
- Black Histic (A3)
- Hydrogen Sulfide (A4)
- Stratified Layers (A5) (**LRR C**)
- 1 cm Muck (A9) (**LRR D**)
- Depleted Below Dark Surface (A11)
- Thick Dark Surface (A12)
- Sandy Mucky Mineral (S1)
- Sandy Gleyed Matrix (S4)

- Sandy Redox (S5)
- Stripped Matrix (S6)
- Loamy Mucky Mineral (F1)
- Loamy Gleyed Matrix (F2)
- Depleted Matrix (F3)
- Redox Dark Surface (F6)
- Depleted Dark Surface (F7)
- Redox Depressions (F8)
- Vernal Pools (F9)

Indicators for Problematic Hydric Soils³:

- 1 cm Muck (A9) (**LRR C**)
- 2 cm Muck (A10) (**LRR B**)
- Reduced Vertic (F18)
- Red Parent Material (TF2)
- Other (Explain in Remarks)

³Indicators of hydrophytic vegetation and wetland hydrology must be present, unless disturbed or problematic.

Restrictive Layer (if present):

Type: _____
 Depth (inches): _____

Hydric Soil Present? Yes No

Remarks:

HYDROLOGY

Wetland Hydrology Indicators:

Primary Indicators (minimum of one required; check all that apply)	Secondary Indicators (2 or more required)
<input checked="" type="checkbox"/> Surface Water (A1)	<input type="checkbox"/> Salt Crust (B11)
<input checked="" type="checkbox"/> High Water Table (A2)	<input type="checkbox"/> Biotic Crust (B12)
<input checked="" type="checkbox"/> Saturation (A3)	<input type="checkbox"/> Aquatic Invertebrates (B13)
<input type="checkbox"/> Water Marks (B1) (Nonriverine)	<input checked="" type="checkbox"/> Hydrogen Sulfide Odor (C1)
<input type="checkbox"/> Sediment Deposits (B2) (Nonriverine)	<input type="checkbox"/> Oxidized Rhizospheres along Living Roots (C3)
<input type="checkbox"/> Drift Deposits (B3) (Nonriverine)	<input type="checkbox"/> Presence of Reduced Iron (C4)
<input type="checkbox"/> Surface Soil Cracks (B6)	<input type="checkbox"/> Recent Iron Reduction in Tilled Soils (C6)
<input type="checkbox"/> Inundation Visible on Aerial Imagery (B7)	<input type="checkbox"/> Thin Muck Surface (C7)
<input type="checkbox"/> Water-Stained Leaves (B9)	<input type="checkbox"/> Other (Explain in Remarks)
	<input type="checkbox"/> Water Marks (B1) (Riverine)
	<input type="checkbox"/> Sediment Deposits (B2) (Riverine)
	<input type="checkbox"/> Drift Deposits (B3) (Riverine)
	<input type="checkbox"/> Drainage Patterns (B10)
	<input type="checkbox"/> Dry-Season Water Table (C2)
	<input type="checkbox"/> Crayfish Burrows (C8)
	<input type="checkbox"/> Saturation Visible on Aerial Imagery (C9)
	<input type="checkbox"/> Shallow Aquitard (D3)
	<input type="checkbox"/> FAC-Neutral Test (D5)

Field Observations:

Surface Water Present? Yes No Depth (inches): 3
 Water Table Present? Yes No Depth (inches): 0
 Saturation Present? Yes No Depth (inches): 0
 (includes capillary fringe)

Wetland Hydrology Present? Yes No

Describe Recorded Data (stream gauge, monitoring well, aerial photos, previous inspections), if available:

Remarks:

WETLAND DETERMINATION DATA FORM – Arid West Region

Project/Site: Vega SES 4 City/County: Holtville/ Imperial County Sampling Date: 11/5/2020
 Applicant/Owner: zGlobal, Inc. State: CA Sampling Point: 6
 Investigator(s): C. Congedo, C. Torres Section, Township, Range: S11, T17S, R16E
 Landform (hillslope, terrace, etc.): Depression Local relief (concave, convex, none): None Slope (%): 5
 Subregion (LRR): D Lat: 32.687512 Long: -115.302089 Datum: NAD83
 Soil Map Unit Name: Rositas fine sand, wet, 0 to 2 percent slopes NWI classification: N/A

Are climatic / hydrologic conditions on the site typical for this time of year? Yes No (If no, explain in Remarks.)
 Are Vegetation , Soil , or Hydrology significantly disturbed? Are "Normal Circumstances" present? Yes No
 Are Vegetation , Soil , or Hydrology naturally problematic? (If needed, explain any answers in Remarks.)

SUMMARY OF FINDINGS – Attach site map showing sampling point locations, transects, important features, etc.

Hydrophytic Vegetation Present? Yes <input checked="" type="checkbox"/> No <input type="checkbox"/> Hydric Soil Present? Yes <input type="checkbox"/> No <input checked="" type="checkbox"/> Wetland Hydrology Present? Yes <input checked="" type="checkbox"/> No <input type="checkbox"/>	Is the Sampled Area within a Wetland? Yes <input type="checkbox"/> No <input checked="" type="checkbox"/>
Remarks:	

VEGETATION – Use scientific names of plants.

Tree Stratum (Plot size: _____)	Absolute % Cover	Dominant Species?	Indicator Status	
1. _____	_____	_____	_____	Dominance Test worksheet: Number of Dominant Species That Are OBL, FACW, or FAC: <u>1</u> (A) Total Number of Dominant Species Across All Strata: <u>1</u> (B) Percent of Dominant Species That Are OBL, FACW, or FAC: <u>100</u> (A/B)
2. _____	_____	_____	_____	
3. _____	_____	_____	_____	
4. _____	_____	_____	_____	
_____ = Total Cover				Prevalence Index worksheet: Total % Cover of: _____ Multiply by: _____ OBL species <u>0</u> x 1 = <u>0</u> FACW species <u>5</u> x 2 = <u>10</u> FAC species <u>0</u> x 3 = <u>0</u> FACU species <u>0</u> x 4 = <u>0</u> UPL species <u>0</u> x 5 = <u>0</u> Column Totals: <u>5</u> (A) <u>10</u> (B) Prevalence Index = B/A = <u>2.0</u>
Sapling/Shrub Stratum (Plot size: <u>15'</u>)				
1. <u>Pluchea sericea</u>	<u>5</u>	<u>x</u>	<u>FACW</u>	
2. _____	_____	_____	_____	
3. _____	_____	_____	_____	
4. _____	_____	_____	_____	
5. _____	_____	_____	_____	
_____ = Total Cover				
Herb Stratum (Plot size: _____)				
1. _____	_____	_____	_____	
2. _____	_____	_____	_____	
3. _____	_____	_____	_____	
4. _____	_____	_____	_____	
5. _____	_____	_____	_____	
6. _____	_____	_____	_____	
7. _____	_____	_____	_____	
8. _____	_____	_____	_____	
_____ = Total Cover				
Woody Vine Stratum (Plot size: _____)				
1. _____	_____	_____	_____	
2. _____	_____	_____	_____	
_____ = Total Cover				
% Bare Ground in Herb Stratum <u>95</u> % Cover of Biotic Crust _____				
Remarks:				

Hydrophytic Vegetation Indicators:
 Dominance Test is >50%
 Prevalence Index is ≤3.0¹
 Morphological Adaptations¹ (Provide supporting data in Remarks or on a separate sheet)
 Problematic Hydrophytic Vegetation¹ (Explain)

¹Indicators of hydric soil and wetland hydrology must be present, unless disturbed or problematic.

Hydrophytic Vegetation Present? Yes No

SOIL

Sampling Point: 6

Profile Description: (Describe to the depth needed to document the indicator or confirm the absence of indicators.)

Depth (inches)	Matrix		Redox Features				Texture	Remarks
	Color (moist)	%	Color (moist)	%	Type ¹	Loc ²		
0-13	7.5YR 4/4	100					Sandy loam	
13-14	10YR 7/3	85	2.5YR 4/8	5			Silty clay	
13-14	Gley 1, 3/N	10					Silty clay	

¹Type: C=Concentration, D=Depletion, RM=Reduced Matrix, CS=Covered or Coated Sand Grains. ²Location: PL=Pore Lining, M=Matrix.

Hydric Soil Indicators: (Applicable to all LRRs, unless otherwise noted.)

- Histosol (A1)
- Histic Epipedon (A2)
- Black Histic (A3)
- Hydrogen Sulfide (A4)
- Stratified Layers (A5) **(LRR C)**
- 1 cm Muck (A9) **(LRR D)**
- Depleted Below Dark Surface (A11)
- Thick Dark Surface (A12)
- Sandy Mucky Mineral (S1)
- Sandy Gleyed Matrix (S4)

- Sandy Redox (S5)
- Stripped Matrix (S6)
- Loamy Mucky Mineral (F1)
- Loamy Gleyed Matrix (F2)
- Depleted Matrix (F3)
- Redox Dark Surface (F6)
- Depleted Dark Surface (F7)
- Redox Depressions (F8)
- Vernal Pools (F9)

Indicators for Problematic Hydric Soils³:

- 1 cm Muck (A9) **(LRR C)**
- 2 cm Muck (A10) **(LRR B)**
- Reduced Vertic (F18)
- Red Parent Material (TF2)
- Other (Explain in Remarks)

³Indicators of hydrophytic vegetation and wetland hydrology must be present, unless disturbed or problematic.

Restrictive Layer (if present):

Type: _____
 Depth (inches): _____

Hydric Soil Present? Yes _____ No

Remarks:

HYDROLOGY

Wetland Hydrology Indicators:

Primary Indicators (minimum of one required; check all that apply)	Secondary Indicators (2 or more required)
<input type="checkbox"/> Surface Water (A1)	<input type="checkbox"/> Water Marks (B1) (Riverine)
<input type="checkbox"/> High Water Table (A2)	<input type="checkbox"/> Sediment Deposits (B2) (Riverine)
<input checked="" type="checkbox"/> Saturation (A3)	<input type="checkbox"/> Drift Deposits (B3) (Riverine)
<input type="checkbox"/> Water Marks (B1) (Nonriverine)	<input type="checkbox"/> Drainage Patterns (B10)
<input type="checkbox"/> Sediment Deposits (B2) (Nonriverine)	<input type="checkbox"/> Dry-Season Water Table (C2)
<input type="checkbox"/> Drift Deposits (B3) (Nonriverine)	<input type="checkbox"/> Crayfish Burrows (C8)
<input type="checkbox"/> Surface Soil Cracks (B6)	<input type="checkbox"/> Saturation Visible on Aerial Imagery (C9)
<input type="checkbox"/> Inundation Visible on Aerial Imagery (B7)	<input type="checkbox"/> Shallow Aquitard (D3)
<input type="checkbox"/> Water-Stained Leaves (B9)	<input checked="" type="checkbox"/> FAC-Neutral Test (D5)
<input type="checkbox"/> Salt Crust (B11)	
<input type="checkbox"/> Biotic Crust (B12)	
<input type="checkbox"/> Aquatic Invertebrates (B13)	
<input type="checkbox"/> Hydrogen Sulfide Odor (C1)	
<input type="checkbox"/> Oxidized Rhizospheres along Living Roots (C3)	
<input type="checkbox"/> Presence of Reduced Iron (C4)	
<input type="checkbox"/> Recent Iron Reduction in Tilled Soils (C6)	
<input type="checkbox"/> Thin Muck Surface (C7)	
<input type="checkbox"/> Other (Explain in Remarks)	

Field Observations:

Surface Water Present? Yes _____ No _____ Depth (inches): _____
 Water Table Present? Yes _____ No _____ Depth (inches): _____
 Saturation Present? Yes No _____ Depth (inches): 0
 (includes capillary fringe)

Wetland Hydrology Present? Yes No _____

Describe Recorded Data (stream gauge, monitoring well, aerial photos, previous inspections), if available:

Remarks:

Salt crust present from agricultural run-off.

WETLAND DETERMINATION DATA FORM – Arid West Region

Project/Site: Vega SES 4 City/County: Holtville/ Imperial County Sampling Date: 11/5/2020
 Applicant/Owner: zGlobal, Inc. State: CA Sampling Point: 7
 Investigator(s): C. Congedo Section, Township, Range: S11, T17S, R16E
 Landform (hillslope, terrace, etc.): Depression Local relief (concave, convex, none): None Slope (%): 5
 Subregion (LRR): D Lat: 32.687200 Long: -115.302318 Datum: NAD83
 Soil Map Unit Name: Rositas fine sand, wet, 0 to 2 percent slopes NWI classification: N/A

Are climatic / hydrologic conditions on the site typical for this time of year? Yes No (If no, explain in Remarks.)
 Are Vegetation , Soil , or Hydrology significantly disturbed? Are "Normal Circumstances" present? Yes No
 Are Vegetation , Soil , or Hydrology naturally problematic? (If needed, explain any answers in Remarks.)

SUMMARY OF FINDINGS – Attach site map showing sampling point locations, transects, important features, etc.

Hydrophytic Vegetation Present? Yes <input checked="" type="checkbox"/> No <input type="checkbox"/> Hydric Soil Present? Yes <input checked="" type="checkbox"/> No <input type="checkbox"/> Wetland Hydrology Present? Yes <input checked="" type="checkbox"/> No <input type="checkbox"/>	Is the Sampled Area within a Wetland? Yes <input checked="" type="checkbox"/> No <input type="checkbox"/>
Remarks: Point taken within tamarisk thickets, downslope (south) of a hard-packed dirt road that runs parallel to the All-American Canal.	

VEGETATION – Use scientific names of plants.

Tree Stratum (Plot size: _____)	Absolute % Cover	Dominant Species?	Indicator Status	
1. _____	_____	_____	_____	Dominance Test worksheet: Number of Dominant Species That Are OBL, FACW, or FAC: <u>1</u> (A) Total Number of Dominant Species Across All Strata: <u>1</u> (B) Percent of Dominant Species That Are OBL, FACW, or FAC: <u>100</u> (A/B)
2. _____	_____	_____	_____	
3. _____	_____	_____	_____	
4. _____	_____	_____	_____	
_____ = Total Cover				Prevalence Index worksheet: Total % Cover of: _____ Multiply by: _____ OBL species <u>8</u> x 1 = <u>8</u> FACW species <u>10</u> x 2 = <u>20</u> FAC species <u>0</u> x 3 = <u>0</u> FACU species <u>0</u> x 4 = <u>0</u> UPL species <u>0</u> x 5 = <u>0</u> Column Totals: <u>18</u> (A) <u>28</u> (B) Prevalence Index = B/A = <u>1.56</u>
Sapling/Shrub Stratum (Plot size: <u>15'</u>)				
1. <u>Pluchea sericea</u>	<u>5</u>		<u>FACW</u>	
2. <u>Baccharis salicina</u>	<u>5</u>		<u>FACW</u>	
3. _____	_____	_____	_____	
4. _____	_____	_____	_____	
5. _____	_____	_____	_____	
_____ = Total Cover				
Herb Stratum (Plot size: <u>15'</u>)				
1. <u>Typha sp.</u>	<u>8</u>	<u>x</u>	<u>OBL</u>	
2. _____	_____	_____	_____	
3. _____	_____	_____	_____	
4. _____	_____	_____	_____	
5. _____	_____	_____	_____	
6. _____	_____	_____	_____	
7. _____	_____	_____	_____	
8. _____	_____	_____	_____	
_____ = Total Cover				
Woody Vine Stratum (Plot size: _____)				
1. _____	_____	_____	_____	
2. _____	_____	_____	_____	
_____ = Total Cover				
% Bare Ground in Herb Stratum <u>82</u> % Cover of Biotic Crust _____				
Remarks:				

Hydrophytic Vegetation Indicators:
 Dominance Test is >50%
 Prevalence Index is ≤3.0¹
 Morphological Adaptations¹ (Provide supporting data in Remarks or on a separate sheet)
 Problematic Hydrophytic Vegetation¹ (Explain)

¹Indicators of hydric soil and wetland hydrology must be present, unless disturbed or problematic.

Hydrophytic Vegetation Present? Yes No

SOIL

Sampling Point: 7

Profile Description: (Describe to the depth needed to document the indicator or confirm the absence of indicators.)

Depth (inches)	Matrix		Redox Features				Texture	Remarks
	Color (moist)	%	Color (moist)	%	Type ¹	Loc ²		
0-6	10YR 5/3	92	7.5YR 5/8	8	C	M, PL	Sandy loam	
6-13+	10YR 6/2	100					Sand	

¹Type: C=Concentration, D=Depletion, RM=Reduced Matrix, CS=Covered or Coated Sand Grains. ²Location: PL=Pore Lining, M=Matrix.

Hydric Soil Indicators: (Applicable to all LRRs, unless otherwise noted.)

- Histosol (A1)
- Histic Epipedon (A2)
- Black Histic (A3)
- Hydrogen Sulfide (A4)
- Stratified Layers (A5) (**LRR C**)
- 1 cm Muck (A9) (**LRR D**)
- Depleted Below Dark Surface (A11)
- Thick Dark Surface (A12)
- Sandy Mucky Mineral (S1)
- Sandy Gleyed Matrix (S4)
- Sandy Redox (S5)
- Stripped Matrix (S6)
- Loamy Mucky Mineral (F1)
- Loamy Gleyed Matrix (F2)
- Depleted Matrix (F3)
- Redox Dark Surface (F6)
- Depleted Dark Surface (F7)
- Redox Depressions (F8)
- Vernal Pools (F9)

Indicators for Problematic Hydric Soils³:

- 1 cm Muck (A9) (**LRR C**)
- 2 cm Muck (A10) (**LRR B**)
- Reduced Vertic (F18)
- Red Parent Material (TF2)
- Other (Explain in Remarks)

³Indicators of hydrophytic vegetation and wetland hydrology must be present, unless disturbed or problematic.

Restrictive Layer (if present):

Type: _____
 Depth (inches): _____

Hydric Soil Present? Yes No

Remarks:

Soil saturated throughout

HYDROLOGY

Wetland Hydrology Indicators:

Primary Indicators (minimum of one required; check all that apply)	Secondary Indicators (2 or more required)
<input type="checkbox"/> Surface Water (A1)	<input type="checkbox"/> Water Marks (B1) (Riverine)
<input type="checkbox"/> High Water Table (A2)	<input type="checkbox"/> Sediment Deposits (B2) (Riverine)
<input checked="" type="checkbox"/> Saturation (A3)	<input type="checkbox"/> Drift Deposits (B3) (Riverine)
<input type="checkbox"/> Water Marks (B1) (Nonriverine)	<input type="checkbox"/> Drainage Patterns (B10)
<input type="checkbox"/> Sediment Deposits (B2) (Nonriverine)	<input type="checkbox"/> Dry-Season Water Table (C2)
<input type="checkbox"/> Drift Deposits (B3) (Nonriverine)	<input type="checkbox"/> Crayfish Burrows (C8)
<input type="checkbox"/> Surface Soil Cracks (B6)	<input type="checkbox"/> Saturation Visible on Aerial Imagery (C9)
<input type="checkbox"/> Inundation Visible on Aerial Imagery (B7)	<input type="checkbox"/> Shallow Aquitard (D3)
<input checked="" type="checkbox"/> Water-Stained Leaves (B9)	<input type="checkbox"/> FAC-Neutral Test (D5)
<input type="checkbox"/> Salt Crust (B11)	
<input type="checkbox"/> Biotic Crust (B12)	
<input type="checkbox"/> Aquatic Invertebrates (B13)	
<input type="checkbox"/> Hydrogen Sulfide Odor (C1)	
<input type="checkbox"/> Oxidized Rhizospheres along Living Roots (C3)	
<input type="checkbox"/> Presence of Reduced Iron (C4)	
<input type="checkbox"/> Recent Iron Reduction in Tilled Soils (C6)	
<input type="checkbox"/> Thin Muck Surface (C7)	
<input type="checkbox"/> Other (Explain in Remarks)	

Field Observations:

Surface Water Present? Yes No Depth (inches): _____
 Water Table Present? Yes No Depth (inches): _____
 Saturation Present? (includes capillary fringe) Yes No Depth (inches): 0

Wetland Hydrology Present? Yes No

Describe Recorded Data (stream gauge, monitoring well, aerial photos, previous inspections), if available:

Remarks:

WETLAND DETERMINATION DATA FORM – Arid West Region

Project/Site: Vega SES 4 City/County: Holtville/ Imperial County Sampling Date: 11/5/2020
 Applicant/Owner: zGlobal, Inc. State: CA Sampling Point: 9
 Investigator(s): C. Congedo Section, Township, Range: S11, T17S, R16E
 Landform (hillslope, terrace, etc.): Depression Local relief (concave, convex, none): None Slope (%): 5
 Subregion (LRR): D Lat: 32.683380 Long: -115.303826 Datum: NAD83
 Soil Map Unit Name: Rositas fine sand, 0 to 2 percent slopes NWI classification: N/A

Are climatic / hydrologic conditions on the site typical for this time of year? Yes No (If no, explain in Remarks.)
 Are Vegetation , Soil , or Hydrology significantly disturbed? Are "Normal Circumstances" present? Yes No
 Are Vegetation , Soil , or Hydrology naturally problematic? (If needed, explain any answers in Remarks.)

SUMMARY OF FINDINGS – Attach site map showing sampling point locations, transects, important features, etc.

Hydrophytic Vegetation Present? Yes <input checked="" type="checkbox"/> No <input type="checkbox"/> Hydric Soil Present? Yes <input type="checkbox"/> No <input checked="" type="checkbox"/> Wetland Hydrology Present? Yes <input checked="" type="checkbox"/> No <input type="checkbox"/>	Is the Sampled Area within a Wetland? Yes <input type="checkbox"/> No <input checked="" type="checkbox"/>
Remarks: Point taken within a slight depression in tamarisk thickets, ~1230 feet downslope (south) of a hard-packed dirt road that runs parallel to the All-American Canal.	

VEGETATION – Use scientific names of plants.

Tree Stratum (Plot size: <u>15'</u>)	Absolute % Cover	Dominant Species?	Indicator Status	
1. <u>Tamarix sp.</u>	<u>2</u>		<u>FAC</u>	Dominance Test worksheet: Number of Dominant Species That Are OBL, FACW, or FAC: <u>1</u> (A) Total Number of Dominant Species Across All Strata: <u>1</u> (B) Percent of Dominant Species That Are OBL, FACW, or FAC: <u>100</u> (A/B)
2. _____				
3. _____				
4. _____				
	<u>2</u>	= Total Cover		
Sapling/Shrub Stratum (Plot size: <u>15'</u>)	Absolute % Cover	Dominant Species?	Indicator Status	
1. <u>Pluchea sericea</u>	<u>10</u>	<u>x</u>	<u>FACW</u>	Prevalence Index worksheet: Total % Cover of: _____ Multiply by: _____ OBL species <u>0</u> x 1 = <u>0</u> FACW species <u>10</u> x 2 = <u>20</u> FAC species <u>2</u> x 3 = <u>6</u> FACU species <u>0</u> x 4 = <u>0</u> UPL species <u>0</u> x 5 = <u>0</u> Column Totals: <u>12</u> (A) <u>26</u> (B) Prevalence Index = B/A = <u>2.17</u>
2. _____				
3. _____				
4. _____				
5. _____				
	<u>10</u>	= Total Cover		
Herb Stratum (Plot size: _____)	Absolute % Cover	Dominant Species?	Indicator Status	
1. _____				Hydrophytic Vegetation Indicators: <input checked="" type="checkbox"/> Dominance Test is >50% <input checked="" type="checkbox"/> Prevalence Index is ≤3.0 ¹ <input type="checkbox"/> Morphological Adaptations ¹ (Provide supporting data in Remarks or on a separate sheet) <input type="checkbox"/> Problematic Hydrophytic Vegetation ¹ (Explain)
2. _____				
3. _____				
4. _____				
5. _____				
6. _____				
7. _____				
8. _____				
	<u>0</u>	= Total Cover		
Woody Vine Stratum (Plot size: _____)	Absolute % Cover	Dominant Species?	Indicator Status	
1. _____				¹ Indicators of hydric soil and wetland hydrology must be present, unless disturbed or problematic.
2. _____				
	<u>0</u>	= Total Cover		
% Bare Ground in Herb Stratum <u>88</u>	% Cover of Biotic Crust _____			Hydrophytic Vegetation Present? Yes <input checked="" type="checkbox"/> No <input type="checkbox"/>

Remarks:

SOIL

Sampling Point: 9

Profile Description: (Describe to the depth needed to document the indicator or confirm the absence of indicators.)

Depth (inches)	Matrix		Redox Features				Texture	Remarks
	Color (moist)	%	Color (moist)	%	Type ¹	Loc ²		
0-13+	7.5YR 4/4	100					Loamy sand	

¹Type: C=Concentration, D=Depletion, RM=Reduced Matrix, CS=Covered or Coated Sand Grains. ²Location: PL=Pore Lining, M=Matrix.

Hydric Soil Indicators: (Applicable to all LRRs, unless otherwise noted.)		Indicators for Problematic Hydric Soils ³ :
<input type="checkbox"/> Histosol (A1)	<input type="checkbox"/> Sandy Redox (S5)	<input type="checkbox"/> 1 cm Muck (A9) (LRR C)
<input type="checkbox"/> Histic Epipedon (A2)	<input type="checkbox"/> Stripped Matrix (S6)	<input type="checkbox"/> 2 cm Muck (A10) (LRR B)
<input type="checkbox"/> Black Histic (A3)	<input type="checkbox"/> Loamy Mucky Mineral (F1)	<input type="checkbox"/> Reduced Vertic (F18)
<input type="checkbox"/> Hydrogen Sulfide (A4)	<input type="checkbox"/> Loamy Gleyed Matrix (F2)	<input type="checkbox"/> Red Parent Material (TF2)
<input type="checkbox"/> Stratified Layers (A5) (LRR C)	<input type="checkbox"/> Depleted Matrix (F3)	<input type="checkbox"/> Other (Explain in Remarks)
<input type="checkbox"/> 1 cm Muck (A9) (LRR D)	<input type="checkbox"/> Redox Dark Surface (F6)	
<input type="checkbox"/> Depleted Below Dark Surface (A11)	<input type="checkbox"/> Depleted Dark Surface (F7)	
<input type="checkbox"/> Thick Dark Surface (A12)	<input type="checkbox"/> Redox Depressions (F8)	
<input type="checkbox"/> Sandy Mucky Mineral (S1)	<input type="checkbox"/> Vernal Pools (F9)	
<input type="checkbox"/> Sandy Gleyed Matrix (S4)		

³Indicators of hydrophytic vegetation and wetland hydrology must be present, unless disturbed or problematic.

Restrictive Layer (if present):
 Type: _____
 Depth (inches): _____

Hydric Soil Present? Yes _____ No

Remarks:
 Dry until about 7", then moist.

HYDROLOGY

Wetland Hydrology Indicators:

Primary Indicators (minimum of one required; check all that apply)	Secondary Indicators (2 or more required)
<input type="checkbox"/> Surface Water (A1)	<input type="checkbox"/> Salt Crust (B11)
<input type="checkbox"/> High Water Table (A2)	<input type="checkbox"/> Biotic Crust (B12)
<input type="checkbox"/> Saturation (A3)	<input type="checkbox"/> Aquatic Invertebrates (B13)
<input type="checkbox"/> Water Marks (B1) (Nonriverine)	<input type="checkbox"/> Hydrogen Sulfide Odor (C1)
<input type="checkbox"/> Sediment Deposits (B2) (Nonriverine)	<input type="checkbox"/> Oxidized Rhizospheres along Living Roots (C3)
<input type="checkbox"/> Drift Deposits (B3) (Nonriverine)	<input type="checkbox"/> Presence of Reduced Iron (C4)
<input type="checkbox"/> Surface Soil Cracks (B6)	<input type="checkbox"/> Recent Iron Reduction in Tilled Soils (C6)
<input type="checkbox"/> Inundation Visible on Aerial Imagery (B7)	<input type="checkbox"/> Thin Muck Surface (C7)
<input checked="" type="checkbox"/> Water-Stained Leaves (B9)	<input type="checkbox"/> Other (Explain in Remarks)
	<input type="checkbox"/> Water Marks (B1) (Riverine)
	<input type="checkbox"/> Sediment Deposits (B2) (Riverine)
	<input type="checkbox"/> Drift Deposits (B3) (Riverine)
	<input type="checkbox"/> Drainage Patterns (B10)
	<input type="checkbox"/> Dry-Season Water Table (C2)
	<input type="checkbox"/> Crayfish Burrows (C8)
	<input type="checkbox"/> Saturation Visible on Aerial Imagery (C9)
	<input type="checkbox"/> Shallow Aquitard (D3)
	<input checked="" type="checkbox"/> FAC-Neutral Test (D5)

Field Observations:

Surface Water Present? Yes _____ No Depth (inches): _____

Water Table Present? Yes _____ No Depth (inches): _____

Saturation Present? Yes _____ No Depth (inches): _____
 (includes capillary fringe)

Wetland Hydrology Present? Yes No _____

Describe Recorded Data (stream gauge, monitoring well, aerial photos, previous inspections), if available:

Remarks:

WETLAND DETERMINATION DATA FORM – Arid West Region

Project/Site: Vega SES 4 City/County: Holtville/ Imperial County Sampling Date: 11/5/2020
 Applicant/Owner: zGlobal, Inc. State: CA Sampling Point: 10
 Investigator(s): C. Congedo Section, Township, Range: S11, T17S, R16E
 Landform (hillslope, terrace, etc.): Depression Local relief (concave, convex, none): Concave Slope (%): 5
 Subregion (LRR): D Lat: 32.684182 Long: -115.307060 Datum: NAD83
 Soil Map Unit Name: Rositas fine sand, wet, 0 to 2 percent slopes NWI classification: N/A

Are climatic / hydrologic conditions on the site typical for this time of year? Yes No (If no, explain in Remarks.)
 Are Vegetation , Soil , or Hydrology significantly disturbed? Are "Normal Circumstances" present? Yes No
 Are Vegetation , Soil , or Hydrology naturally problematic? (If needed, explain any answers in Remarks.)

SUMMARY OF FINDINGS – Attach site map showing sampling point locations, transects, important features, etc.

Hydrophytic Vegetation Present? Yes <input checked="" type="checkbox"/> No <input type="checkbox"/> Hydric Soil Present? Yes <input type="checkbox"/> No <input checked="" type="checkbox"/> Wetland Hydrology Present? Yes <input checked="" type="checkbox"/> No <input type="checkbox"/>	Is the Sampled Area within a Wetland? Yes <input type="checkbox"/> No <input checked="" type="checkbox"/>
Remarks: Point taken on the outskirts of a slight depression in tamarisk thickets, ~500 feet downslope (south) of a hard-packed dirt road that runs parallel to the All-American Canal.	

VEGETATION – Use scientific names of plants.

Tree Stratum (Plot size: _____)	Absolute % Cover	Dominant Species?	Indicator Status	
1. <u>Tamarix sp.</u>	<u>3</u>		<u>FAC</u>	Dominance Test worksheet: Number of Dominant Species That Are OBL, FACW, or FAC: <u>1</u> (A) Total Number of Dominant Species Across All Strata: <u>1</u> (B) Percent of Dominant Species That Are OBL, FACW, or FAC: <u>100</u> (A/B)
2. _____				
3. _____				
4. _____				
	<u>3</u>	= Total Cover		
Sapling/Shrub Stratum (Plot size: <u>20'</u>)				
1. <u>Pluchea sericea</u>	<u>8</u>	<u>x</u>	<u>FACW</u>	Prevalence Index worksheet: Total % Cover of: _____ Multiply by: _____ OBL species <u>0</u> x 1 = <u>0</u> FACW species <u>8</u> x 2 = <u>16</u> FAC species <u>3</u> x 3 = <u>9</u> FACU species <u>2</u> x 4 = <u>8</u> UPL species <u>0</u> x 5 = <u>0</u> Column Totals: <u>13</u> (A) <u>33</u> (B) Prevalence Index = B/A = <u>2.54</u>
2. <u>Isocoma acradenia</u>	<u>2</u>		<u>FACU</u>	
3. _____				
4. _____				
5. _____				
	<u>10</u>	= Total Cover		
Herb Stratum (Plot size: _____)				
1. _____				Hydrophytic Vegetation Indicators: <input checked="" type="checkbox"/> Dominance Test is >50% <input checked="" type="checkbox"/> Prevalence Index is ≤3.0 ¹ <input type="checkbox"/> Morphological Adaptations ¹ (Provide supporting data in Remarks or on a separate sheet) <input type="checkbox"/> Problematic Hydrophytic Vegetation ¹ (Explain) ¹ Indicators of hydric soil and wetland hydrology must be present, unless disturbed or problematic.
2. _____				
3. _____				
4. _____				
5. _____				
6. _____				
7. _____				
8. _____				
	<u>0</u>	= Total Cover		
Woody Vine Stratum (Plot size: _____)				
1. _____				Hydrophytic Vegetation Present? Yes <input checked="" type="checkbox"/> No <input type="checkbox"/>
2. _____				
	<u>0</u>	= Total Cover		
% Bare Ground in Herb Stratum <u>87</u> % Cover of Biotic Crust _____				

Remarks:

SOIL

Sampling Point: 10

Profile Description: (Describe to the depth needed to document the indicator or confirm the absence of indicators.)								
Depth (inches)	Matrix		Redox Features				Texture	Remarks
	Color (moist)	%	Color (moist)	%	Type ¹	Loc ²		
0-13+	7.5YR 4/4	100					Loamy sand	

¹Type: C=Concentration, D=Depletion, RM=Reduced Matrix, CS=Covered or Coated Sand Grains. ²Location: PL=Pore Lining, M=Matrix.

Hydric Soil Indicators: (Applicable to all LRRs, unless otherwise noted.)	Indicators for Problematic Hydric Soils ³ :
<input type="checkbox"/> Histosol (A1) <input type="checkbox"/> Histic Epipedon (A2) <input type="checkbox"/> Black Histic (A3) <input type="checkbox"/> Hydrogen Sulfide (A4) <input type="checkbox"/> Stratified Layers (A5) (LRR C) <input type="checkbox"/> 1 cm Muck (A9) (LRR D) <input type="checkbox"/> Depleted Below Dark Surface (A11) <input type="checkbox"/> Thick Dark Surface (A12) <input type="checkbox"/> Sandy Mucky Mineral (S1) <input type="checkbox"/> Sandy Gleyed Matrix (S4)	<input type="checkbox"/> Sandy Redox (S5) <input type="checkbox"/> Stripped Matrix (S6) <input type="checkbox"/> Loamy Mucky Mineral (F1) <input type="checkbox"/> Loamy Gleyed Matrix (F2) <input type="checkbox"/> Depleted Matrix (F3) <input type="checkbox"/> Redox Dark Surface (F6) <input type="checkbox"/> Depleted Dark Surface (F7) <input type="checkbox"/> Redox Depressions (F8) <input type="checkbox"/> Vernal Pools (F9)
	<input type="checkbox"/> 1 cm Muck (A9) (LRR C) <input type="checkbox"/> 2 cm Muck (A10) (LRR B) <input type="checkbox"/> Reduced Vertic (F18) <input type="checkbox"/> Red Parent Material (TF2) <input type="checkbox"/> Other (Explain in Remarks)

³Indicators of hydrophytic vegetation and wetland hydrology must be present, unless disturbed or problematic.

Restrictive Layer (if present):	Hydric Soil Present? Yes ___ No <input checked="" type="checkbox"/>
Type: _____	
Depth (inches): _____	

Remarks:
Moist 8" from surface.

HYDROLOGY

Wetland Hydrology Indicators:	
Primary Indicators (minimum of one required; check all that apply)	Secondary Indicators (2 or more required)
<input type="checkbox"/> Surface Water (A1) <input type="checkbox"/> High Water Table (A2) <input type="checkbox"/> Saturation (A3) <input type="checkbox"/> Water Marks (B1) (Nonriverine) <input checked="" type="checkbox"/> Sediment Deposits (B2) (Nonriverine) <input type="checkbox"/> Drift Deposits (B3) (Nonriverine) <input type="checkbox"/> Surface Soil Cracks (B6) <input type="checkbox"/> Inundation Visible on Aerial Imagery (B7) <input checked="" type="checkbox"/> Water-Stained Leaves (B9)	<input type="checkbox"/> Salt Crust (B11) <input type="checkbox"/> Biotic Crust (B12) <input type="checkbox"/> Aquatic Invertebrates (B13) <input type="checkbox"/> Hydrogen Sulfide Odor (C1) <input type="checkbox"/> Oxidized Rhizospheres along Living Roots (C3) <input type="checkbox"/> Presence of Reduced Iron (C4) <input type="checkbox"/> Recent Iron Reduction in Tilled Soils (C6) <input type="checkbox"/> Thin Muck Surface (C7) <input type="checkbox"/> Other (Explain in Remarks)
	<input type="checkbox"/> Water Marks (B1) (Riverine) <input type="checkbox"/> Sediment Deposits (B2) (Riverine) <input type="checkbox"/> Drift Deposits (B3) (Riverine) <input type="checkbox"/> Drainage Patterns (B10) <input type="checkbox"/> Dry-Season Water Table (C2) <input type="checkbox"/> Crayfish Burrows (C8) <input type="checkbox"/> Saturation Visible on Aerial Imagery (C9) <input type="checkbox"/> Shallow Aquitard (D3) <input type="checkbox"/> FAC-Neutral Test (D5)

Field Observations:	Wetland Hydrology Present? Yes <input checked="" type="checkbox"/> No ___
Surface Water Present? Yes ___ No <input checked="" type="checkbox"/> Depth (inches): _____	
Water Table Present? Yes ___ No <input checked="" type="checkbox"/> Depth (inches): _____	
Saturation Present? (includes capillary fringe) Yes ___ No <input checked="" type="checkbox"/> Depth (inches): _____	

Describe Recorded Data (stream gauge, monitoring well, aerial photos, previous inspections), if available:

Remarks:

WETLAND DETERMINATION DATA FORM – Arid West Region

Project/Site: Vega SES 4 City/County: Holtville/ Imperial County Sampling Date: 11/5/2020
 Applicant/Owner: zGlobal, Inc. State: CA Sampling Point: 11
 Investigator(s): C. Congedo Section, Township, Range: S11, T17S, R16E
 Landform (hillslope, terrace, etc.): Depression Local relief (concave, convex, none): Concave Slope (%): 5
 Subregion (LRR): D Lat: 32.684568 Long: -115.307297 Datum: NAD83
 Soil Map Unit Name: Rositas fine sand, wet, 0 to 2 percent slopes NWI classification: N/A

Are climatic / hydrologic conditions on the site typical for this time of year? Yes No (If no, explain in Remarks.)
 Are Vegetation , Soil , or Hydrology significantly disturbed? Are "Normal Circumstances" present? Yes No
 Are Vegetation , Soil , or Hydrology naturally problematic? (If needed, explain any answers in Remarks.)

SUMMARY OF FINDINGS – Attach site map showing sampling point locations, transects, important features, etc.

Hydrophytic Vegetation Present? Yes <input checked="" type="checkbox"/> No <input type="checkbox"/> Hydric Soil Present? Yes <input checked="" type="checkbox"/> No <input type="checkbox"/> Wetland Hydrology Present? Yes <input checked="" type="checkbox"/> No <input type="checkbox"/>	Is the Sampled Area within a Wetland? Yes <input checked="" type="checkbox"/> No <input type="checkbox"/>
Remarks: Point taken within a slight depression in tamarisk thickets, ~300 feet downslope (south) of a hard-packed dirt road that runs parallel to the All-American Canal.	

VEGETATION – Use scientific names of plants.

Tree Stratum (Plot size: <u>20'</u>)	Absolute % Cover	Dominant Species?	Indicator Status	
1. <u>Tamarix sp.</u>	<u>2</u>		<u>FAC</u>	Dominance Test worksheet: Number of Dominant Species That Are OBL, FACW, or FAC: <u>1</u> (A) Total Number of Dominant Species Across All Strata: <u>1</u> (B) Percent of Dominant Species That Are OBL, FACW, or FAC: <u>100</u> (A/B)
2. _____				
3. _____				
4. _____				
	<u>2</u>	= Total Cover		
Sapling/Shrub Stratum (Plot size: <u>20'</u>)				
1. <u>Pluchea sericea</u>	<u>15</u>	<u>x</u>	<u>FACW</u>	Prevalence Index worksheet: Total % Cover of: _____ Multiply by: _____ OBL species <u>0</u> x 1 = <u>0</u> FACW species <u>15</u> x 2 = <u>30</u> FAC species <u>7</u> x 3 = <u>21</u> FACU species <u>0</u> x 4 = <u>0</u> UPL species <u>0</u> x 5 = <u>0</u> Column Totals: <u>22</u> (A) <u>51</u> (B) Prevalence Index = B/A = <u>2.32</u>
2. <u>Tamarix sp.</u>	<u>5</u>		<u>FAC</u>	
3. _____				
4. _____				
5. _____				
	<u>20</u>	= Total Cover		
Herb Stratum (Plot size: _____)				
1. _____				Hydrophytic Vegetation Indicators: <input checked="" type="checkbox"/> Dominance Test is >50% <input checked="" type="checkbox"/> Prevalence Index is ≤3.0 ¹ <input type="checkbox"/> Morphological Adaptations ¹ (Provide supporting data in Remarks or on a separate sheet) <input type="checkbox"/> Problematic Hydrophytic Vegetation ¹ (Explain)
2. _____				
3. _____				
4. _____				
5. _____				
6. _____				
7. _____				
8. _____				
	<u>0</u>	= Total Cover		
Woody Vine Stratum (Plot size: _____)				
1. _____				¹ Indicators of hydric soil and wetland hydrology must be present, unless disturbed or problematic.
2. _____				
	<u>0</u>	= Total Cover		
% Bare Ground in Herb Stratum <u>78</u> % Cover of Biotic Crust _____				
Hydrophytic Vegetation Present? Yes <input checked="" type="checkbox"/> No <input type="checkbox"/>				

Remarks:

SOIL

Sampling Point: 11

Profile Description: (Describe to the depth needed to document the indicator or confirm the absence of indicators.)								
Depth (inches)	Matrix		Redox Features				Texture	Remarks
	Color (moist)	%	Color (moist)	%	Type ¹	Loc ²		
0-1	Gley 1, 2.5/N	65	7.5YR 4/4	35			Loamy s _{cl}	
1-4	7.5YR 4/4	100					Loamy s _{cl}	
4-12	7.5YR 4/4	94	5Y 4/6	6	C	PL	Loam	
¹ Type: C=Concentration, D=Depletion, RM=Reduced Matrix, CS=Covered or Coated Sand Grains. ² Location: PL=Pore Lining, M=Matrix.								
Hydric Soil Indicators: (Applicable to all LRRs, unless otherwise noted.)						Indicators for Problematic Hydric Soils³:		
<input type="checkbox"/> Histosol (A1)			<input type="checkbox"/> Sandy Redox (S5)			<input type="checkbox"/> 1 cm Muck (A9) (LRR C)		
<input type="checkbox"/> Histic Epipedon (A2)			<input type="checkbox"/> Stripped Matrix (S6)			<input type="checkbox"/> 2 cm Muck (A10) (LRR B)		
<input type="checkbox"/> Black Histic (A3)			<input type="checkbox"/> Loamy Mucky Mineral (F1)			<input type="checkbox"/> Reduced Vertic (F18)		
<input type="checkbox"/> Hydrogen Sulfide (A4)			<input type="checkbox"/> Loamy Gleyed Matrix (F2)			<input type="checkbox"/> Red Parent Material (TF2)		
<input type="checkbox"/> Stratified Layers (A5) (LRR C)			<input type="checkbox"/> Depleted Matrix (F3)			<input type="checkbox"/> Other (Explain in Remarks)		
<input type="checkbox"/> 1 cm Muck (A9) (LRR D)			<input type="checkbox"/> Redox Dark Surface (F6)			³ Indicators of hydrophytic vegetation and wetland hydrology must be present, unless disturbed or problematic.		
<input type="checkbox"/> Depleted Below Dark Surface (A11)			<input type="checkbox"/> Depleted Dark Surface (F7)					
<input type="checkbox"/> Thick Dark Surface (A12)			<input checked="" type="checkbox"/> Redox Depressions (F8)					
<input type="checkbox"/> Sandy Mucky Mineral (S1)			<input type="checkbox"/> Vernal Pools (F9)					
<input type="checkbox"/> Sandy Gleyed Matrix (S4)								
Restrictive Layer (if present):								
Type: _____								
Depth (inches): _____						Hydric Soil Present? Yes <input checked="" type="checkbox"/> No <input type="checkbox"/>		
Remarks:								

HYDROLOGY

Wetland Hydrology Indicators:					
Primary Indicators (minimum of one required; check all that apply)			Secondary Indicators (2 or more required)		
<input type="checkbox"/> Surface Water (A1)	<input type="checkbox"/> Salt Crust (B11)	<input type="checkbox"/> Water Marks (B1) (Riverine)			
<input type="checkbox"/> High Water Table (A2)	<input type="checkbox"/> Biotic Crust (B12)	<input type="checkbox"/> Sediment Deposits (B2) (Riverine)			
<input type="checkbox"/> Saturation (A3)	<input type="checkbox"/> Aquatic Invertebrates (B13)	<input type="checkbox"/> Drift Deposits (B3) (Riverine)			
<input type="checkbox"/> Water Marks (B1) (Nonriverine)	<input type="checkbox"/> Hydrogen Sulfide Odor (C1)	<input type="checkbox"/> Drainage Patterns (B10)			
<input checked="" type="checkbox"/> Sediment Deposits (B2) (Nonriverine)	<input type="checkbox"/> Oxidized Rhizospheres along Living Roots (C3)	<input type="checkbox"/> Dry-Season Water Table (C2)			
<input checked="" type="checkbox"/> Drift Deposits (B3) (Nonriverine)	<input type="checkbox"/> Presence of Reduced Iron (C4)	<input type="checkbox"/> Crayfish Burrows (C8)			
<input type="checkbox"/> Surface Soil Cracks (B6)	<input type="checkbox"/> Recent Iron Reduction in Tilled Soils (C6)	<input type="checkbox"/> Saturation Visible on Aerial Imagery (C9)			
<input type="checkbox"/> Inundation Visible on Aerial Imagery (B7)	<input type="checkbox"/> Thin Muck Surface (C7)	<input type="checkbox"/> Shallow Aquitard (D3)			
<input type="checkbox"/> Water-Stained Leaves (B9)	<input type="checkbox"/> Other (Explain in Remarks)	<input checked="" type="checkbox"/> FAC-Neutral Test (D5)			
Field Observations:					
Surface Water Present?	Yes <input type="checkbox"/> No <input checked="" type="checkbox"/>	Depth (inches): _____	Wetland Hydrology Present? Yes <input checked="" type="checkbox"/> No <input type="checkbox"/>		
Water Table Present?	Yes <input type="checkbox"/> No <input checked="" type="checkbox"/>	Depth (inches): _____			
Saturation Present? (includes capillary fringe)	Yes <input type="checkbox"/> No <input checked="" type="checkbox"/>	Depth (inches): _____			
Describe Recorded Data (stream gauge, monitoring well, aerial photos, previous inspections), if available:					
Remarks:					
Moist soils from 3" down.					

WETLAND DETERMINATION DATA FORM – Arid West Region

Project/Site: Vega SES 4 City/County: Holtville/ Imperial County Sampling Date: 11/5/2020
 Applicant/Owner: zGlobal, Inc. State: CA Sampling Point: 12
 Investigator(s): C. Congedo Section, Township, Range: S11, T17S, R16E
 Landform (hillslope, terrace, etc.): Depression Local relief (concave, convex, none): Concave Slope (%): 3
 Subregion (LRR): D Lat: 32.683847 Long: -115.309409 Datum: NAD83
 Soil Map Unit Name: Rositas fine sand, wet, 0 to 2 percent slopes NWI classification: N/A

Are climatic / hydrologic conditions on the site typical for this time of year? Yes No (If no, explain in Remarks.)
 Are Vegetation , Soil , or Hydrology significantly disturbed? Are "Normal Circumstances" present? Yes No
 Are Vegetation , Soil , or Hydrology naturally problematic? (If needed, explain any answers in Remarks.)

SUMMARY OF FINDINGS – Attach site map showing sampling point locations, transects, important features, etc.

Hydrophytic Vegetation Present? Yes <input checked="" type="checkbox"/> No <input type="checkbox"/> Hydric Soil Present? Yes <input checked="" type="checkbox"/> No <input type="checkbox"/> Wetland Hydrology Present? Yes <input checked="" type="checkbox"/> No <input type="checkbox"/>	Is the Sampled Area within a Wetland? Yes <input checked="" type="checkbox"/> No <input type="checkbox"/>
Remarks: Point taken within a slight depression in tamarisk thickets, ~300 feet downslope (south) of a hard-packed dirt road that runs parallel to the All-American Canal.	

VEGETATION – Use scientific names of plants.

Tree Stratum (Plot size: <u>20'</u>)	Absolute % Cover	Dominant Species?	Indicator Status	
1. <u>Tamarix sp.</u>	<u>5</u>		<u>FAC</u>	Dominance Test worksheet: Number of Dominant Species That Are OBL, FACW, or FAC: <u>1</u> (A) Total Number of Dominant Species Across All Strata: <u>1</u> (B) Percent of Dominant Species That Are OBL, FACW, or FAC: <u>100</u> (A/B)
2. _____				
3. _____				
4. _____				
	<u>5</u>	= Total Cover		
Sapling/Shrub Stratum (Plot size: _____)				
1. <u>Tamarix sp.</u>	<u>2</u>		<u>FAC</u>	Prevalence Index worksheet: Total % Cover of: _____ Multiply by: _____ OBL species <u>0</u> x 1 = <u>0</u> FACW species <u>15</u> x 2 = <u>30</u> FAC species <u>7</u> x 3 = <u>21</u> FACU species <u>0</u> x 4 = <u>0</u> UPL species <u>0</u> x 5 = <u>0</u> Column Totals: <u>22</u> (A) <u>51</u> (B) Prevalence Index = B/A = <u>2.32</u>
2. <u>Pluchea sericea</u>	<u>15</u>	<u>x</u>	<u>FACW</u>	
3. _____				
4. _____				
5. _____				
	<u>17</u>	= Total Cover		
Herb Stratum (Plot size: _____)				
1. _____				Hydrophytic Vegetation Indicators: <input checked="" type="checkbox"/> Dominance Test is >50% <input checked="" type="checkbox"/> Prevalence Index is ≤3.0 ¹ <input type="checkbox"/> Morphological Adaptations ¹ (Provide supporting data in Remarks or on a separate sheet) <input type="checkbox"/> Problematic Hydrophytic Vegetation ¹ (Explain)
2. _____				
3. _____				
4. _____				
5. _____				
6. _____				
7. _____				
8. _____				
	<u>0</u>	= Total Cover		
Woody Vine Stratum (Plot size: _____)				
1. _____				¹ Indicators of hydric soil and wetland hydrology must be present, unless disturbed or problematic.
2. _____				
	<u>0</u>	= Total Cover		
% Bare Ground in Herb Stratum <u>78</u> % Cover of Biotic Crust _____				Hydrophytic Vegetation Present? Yes <input checked="" type="checkbox"/> No <input type="checkbox"/>

Remarks:

SOIL

Sampling Point: 12

Profile Description: (Describe to the depth needed to document the indicator or confirm the absence of indicators.)								
Depth (inches)	Matrix		Redox Features				Texture	Remarks
	Color (moist)	%	Color (moist)	%	Type ¹	Loc ²		
0-1	Gley 1, 5/N	70					Loamy sand	
0-1	7.5YR 4/4	30					Loamy sand	
1-3	7.5YR 4/4	97	Gley 1, 5/N	3	C	M	Loamy sand	
3-12	7.5YR 4/4	95	7.5YR 5/8	5	C	M	Loamy sand	
¹ Type: C=Concentration, D=Depletion, RM=Reduced Matrix, CS=Covered or Coated Sand Grains. ² Location: PL=Pore Lining, M=Matrix.								
Hydric Soil Indicators: (Applicable to all LRRs, unless otherwise noted.)						Indicators for Problematic Hydric Soils³:		
<input type="checkbox"/> Histosol (A1)			<input type="checkbox"/> Sandy Redox (S5)			<input type="checkbox"/> 1 cm Muck (A9) (LRR C)		
<input type="checkbox"/> Histic Epipedon (A2)			<input type="checkbox"/> Stripped Matrix (S6)			<input type="checkbox"/> 2 cm Muck (A10) (LRR B)		
<input type="checkbox"/> Black Histic (A3)			<input type="checkbox"/> Loamy Mucky Mineral (F1)			<input type="checkbox"/> Reduced Vertic (F18)		
<input type="checkbox"/> Hydrogen Sulfide (A4)			<input type="checkbox"/> Loamy Gleyed Matrix (F2)			<input type="checkbox"/> Red Parent Material (TF2)		
<input type="checkbox"/> Stratified Layers (A5) (LRR C)			<input type="checkbox"/> Depleted Matrix (F3)			<input type="checkbox"/> Other (Explain in Remarks)		
<input type="checkbox"/> 1 cm Muck (A9) (LRR D)			<input type="checkbox"/> Redox Dark Surface (F6)			³ Indicators of hydrophytic vegetation and wetland hydrology must be present, unless disturbed or problematic.		
<input type="checkbox"/> Depleted Below Dark Surface (A11)			<input type="checkbox"/> Depleted Dark Surface (F7)					
<input type="checkbox"/> Thick Dark Surface (A12)			<input type="checkbox"/> Redox Depressions (F8)					
<input type="checkbox"/> Sandy Mucky Mineral (S1)			<input type="checkbox"/> Vernal Pools (F9)					
<input checked="" type="checkbox"/> Sandy Gleyed Matrix (S4)								
Restrictive Layer (if present):						Hydric Soil Present? Yes <input checked="" type="checkbox"/> No <input type="checkbox"/>		
Type: _____								
Depth (inches): _____								
Remarks:								

HYDROLOGY

Wetland Hydrology Indicators:		
Primary Indicators (minimum of one required; check all that apply)	Secondary Indicators (2 or more required)	
<input type="checkbox"/> Surface Water (A1)	<input type="checkbox"/> Salt Crust (B11)	<input type="checkbox"/> Water Marks (B1) (Riverine)
<input type="checkbox"/> High Water Table (A2)	<input type="checkbox"/> Biotic Crust (B12)	<input type="checkbox"/> Sediment Deposits (B2) (Riverine)
<input type="checkbox"/> Saturation (A3)	<input type="checkbox"/> Aquatic Invertebrates (B13)	<input type="checkbox"/> Drift Deposits (B3) (Riverine)
<input type="checkbox"/> Water Marks (B1) (Nonriverine)	<input type="checkbox"/> Hydrogen Sulfide Odor (C1)	<input type="checkbox"/> Drainage Patterns (B10)
<input checked="" type="checkbox"/> Sediment Deposits (B2) (Nonriverine)	<input type="checkbox"/> Oxidized Rhizospheres along Living Roots (C3)	<input type="checkbox"/> Dry-Season Water Table (C2)
<input type="checkbox"/> Drift Deposits (B3) (Nonriverine)	<input type="checkbox"/> Presence of Reduced Iron (C4)	<input type="checkbox"/> Crayfish Burrows (C8)
<input type="checkbox"/> Surface Soil Cracks (B6)	<input type="checkbox"/> Recent Iron Reduction in Tilled Soils (C6)	<input type="checkbox"/> Saturation Visible on Aerial Imagery (C9)
<input type="checkbox"/> Inundation Visible on Aerial Imagery (B7)	<input type="checkbox"/> Thin Muck Surface (C7)	<input type="checkbox"/> Shallow Aquitard (D3)
<input checked="" type="checkbox"/> Water-Stained Leaves (B9)	<input type="checkbox"/> Other (Explain in Remarks)	<input checked="" type="checkbox"/> FAC-Neutral Test (D5)
Field Observations:		
Surface Water Present? Yes _____ No <input checked="" type="checkbox"/>	Depth (inches): _____	
Water Table Present? Yes _____ No <input checked="" type="checkbox"/>	Depth (inches): _____	
Saturation Present? (includes capillary fringe) Yes _____ No <input checked="" type="checkbox"/>	Depth (inches): _____	
Wetland Hydrology Present? Yes <input checked="" type="checkbox"/> No <input type="checkbox"/>		
Describe Recorded Data (stream gauge, monitoring well, aerial photos, previous inspections), if available:		
Remarks:		
Moist at 7" deep.		

WETLAND DETERMINATION DATA FORM – Arid West Region

Project/Site: Vega SES 4 City/County: Holtville/ Imperial County Sampling Date: 11/5/2020
 Applicant/Owner: zGlobal, Inc. State: CA Sampling Point: 13
 Investigator(s): C. Congedo Section, Township, Range: S10, T17S, R16E
 Landform (hillslope, terrace, etc.): Depression Local relief (concave, convex, none): Concave Slope (%): 3
 Subregion (LRR): D Lat: 32.683831 Long: -115.310470 Datum: NAD83
 Soil Map Unit Name: Rositas fine sand, wet, 0 to 2 percent slopes NWI classification: N/A

Are climatic / hydrologic conditions on the site typical for this time of year? Yes No (If no, explain in Remarks.)
 Are Vegetation , Soil , or Hydrology significantly disturbed? Are "Normal Circumstances" present? Yes No
 Are Vegetation , Soil , or Hydrology naturally problematic? (If needed, explain any answers in Remarks.)

SUMMARY OF FINDINGS – Attach site map showing sampling point locations, transects, important features, etc.

Hydrophytic Vegetation Present? Yes <input checked="" type="checkbox"/> No <input type="checkbox"/> Hydric Soil Present? Yes <input type="checkbox"/> No <input checked="" type="checkbox"/> Wetland Hydrology Present? Yes <input checked="" type="checkbox"/> No <input type="checkbox"/>	Is the Sampled Area within a Wetland? Yes <input type="checkbox"/> No <input checked="" type="checkbox"/>
Remarks: Point taken on the outskirts of a slight depression in tamarisk thickets, ~200 feet downslope (south) of a hard-packed dirt road that runs parallel to the All-American Canal.	

VEGETATION – Use scientific names of plants.

Tree Stratum (Plot size: <u>15'</u>)	Absolute % Cover	Dominant Species?	Indicator Status	
1. <u>Tamarix sp.</u>	<u>2</u>		<u>FAC</u>	Dominance Test worksheet: Number of Dominant Species That Are OBL, FACW, or FAC: <u>1</u> (A) Total Number of Dominant Species Across All Strata: <u>1</u> (B) Percent of Dominant Species That Are OBL, FACW, or FAC: <u>100</u> (A/B)
2. _____				
3. _____				
4. _____				
	<u>2</u>	= Total Cover		
Sapling/Shrub Stratum (Plot size: <u>15'</u>)	Absolute % Cover	Dominant Species?	Indicator Status	
1. <u>Isocoma acradenia</u>	<u>4</u>		<u>FACU</u>	Prevalence Index worksheet: Total % Cover of: _____ Multiply by: _____ OBL species <u>0</u> x 1 = <u>0</u> FACW species <u>8</u> x 2 = <u>16</u> FAC species <u>2</u> x 3 = <u>6</u> FACU species <u>4</u> x 4 = <u>16</u> UPL species <u>0</u> x 5 = <u>0</u> Column Totals: <u>14</u> (A) <u>38</u> (B) Prevalence Index = B/A = <u>2.71</u>
2. <u>Pluchea sericea</u>	<u>8</u>	<u>x</u>	<u>FACW</u>	
3. _____				
4. _____				
5. _____				
	<u>12</u>	= Total Cover		
Herb Stratum (Plot size: _____)	Absolute % Cover	Dominant Species?	Indicator Status	
1. _____				Hydrophytic Vegetation Indicators: <input checked="" type="checkbox"/> Dominance Test is >50% <input checked="" type="checkbox"/> Prevalence Index is ≤3.0 ¹ <input type="checkbox"/> Morphological Adaptations ¹ (Provide supporting data in Remarks or on a separate sheet) <input type="checkbox"/> Problematic Hydrophytic Vegetation ¹ (Explain)
2. _____				
3. _____				
4. _____				
5. _____				
6. _____				
7. _____				
8. _____				
	<u>0</u>	= Total Cover		
Woody Vine Stratum (Plot size: _____)	Absolute % Cover	Dominant Species?	Indicator Status	
1. _____				¹ Indicators of hydric soil and wetland hydrology must be present, unless disturbed or problematic.
2. _____				
	<u>0</u>	= Total Cover		
% Bare Ground in Herb Stratum <u>86</u> % Cover of Biotic Crust _____				Hydrophytic Vegetation Present? Yes <input checked="" type="checkbox"/> No <input type="checkbox"/>

Remarks:

SOIL

Sampling Point: 13

Profile Description: (Describe to the depth needed to document the indicator or confirm the absence of indicators.)

Depth (inches)	Matrix		Redox Features				Texture	Remarks
	Color (moist)	%	Color (moist)	%	Type ¹	Loc ²		
0-7	7.5YR 4/4	100					Loamy s _c	
7-14	7.5YR 4/4	97	7.5YR 5/8	3	C	PL	Loamy s _c	

¹Type: C=Concentration, D=Depletion, RM=Reduced Matrix, CS=Covered or Coated Sand Grains. ²Location: PL=Pore Lining, M=Matrix.

Hydric Soil Indicators: (Applicable to all LRRs, unless otherwise noted.)

<input type="checkbox"/> Histosol (A1)	<input type="checkbox"/> Sandy Redox (S5)	<input type="checkbox"/> 1 cm Muck (A9) (LRR C)
<input type="checkbox"/> Histic Epipedon (A2)	<input type="checkbox"/> Stripped Matrix (S6)	<input type="checkbox"/> 2 cm Muck (A10) (LRR B)
<input type="checkbox"/> Black Histic (A3)	<input type="checkbox"/> Loamy Mucky Mineral (F1)	<input type="checkbox"/> Reduced Vertic (F18)
<input type="checkbox"/> Hydrogen Sulfide (A4)	<input type="checkbox"/> Loamy Gleyed Matrix (F2)	<input type="checkbox"/> Red Parent Material (TF2)
<input type="checkbox"/> Stratified Layers (A5) (LRR C)	<input type="checkbox"/> Depleted Matrix (F3)	<input type="checkbox"/> Other (Explain in Remarks)
<input type="checkbox"/> 1 cm Muck (A9) (LRR D)	<input type="checkbox"/> Redox Dark Surface (F6)	
<input type="checkbox"/> Depleted Below Dark Surface (A11)	<input type="checkbox"/> Depleted Dark Surface (F7)	
<input type="checkbox"/> Thick Dark Surface (A12)	<input type="checkbox"/> Redox Depressions (F8)	
<input type="checkbox"/> Sandy Mucky Mineral (S1)	<input type="checkbox"/> Vernal Pools (F9)	
<input type="checkbox"/> Sandy Gleyed Matrix (S4)		

Indicators for Problematic Hydric Soils³:

³Indicators of hydrophytic vegetation and wetland hydrology must be present, unless disturbed or problematic.

Restrictive Layer (if present):
 Type: _____
 Depth (inches): _____

Hydric Soil Present? Yes _____ No

Remarks:

HYDROLOGY

Wetland Hydrology Indicators:

Primary Indicators (minimum of one required; check all that apply)	Secondary Indicators (2 or more required)
<input type="checkbox"/> Surface Water (A1)	<input type="checkbox"/> Water Marks (B1) (Riverine)
<input type="checkbox"/> High Water Table (A2)	<input type="checkbox"/> Sediment Deposits (B2) (Riverine)
<input type="checkbox"/> Saturation (A3)	<input type="checkbox"/> Drift Deposits (B3) (Riverine)
<input type="checkbox"/> Water Marks (B1) (Nonriverine)	<input type="checkbox"/> Drainage Patterns (B10)
<input checked="" type="checkbox"/> Sediment Deposits (B2) (Nonriverine)	<input type="checkbox"/> Dry-Season Water Table (C2)
<input checked="" type="checkbox"/> Drift Deposits (B3) (Nonriverine)	<input type="checkbox"/> Crayfish Burrows (C8)
<input type="checkbox"/> Surface Soil Cracks (B6)	<input type="checkbox"/> Saturation Visible on Aerial Imagery (C9)
<input type="checkbox"/> Inundation Visible on Aerial Imagery (B7)	<input type="checkbox"/> Shallow Aquitard (D3)
<input checked="" type="checkbox"/> Water-Stained Leaves (B9)	<input type="checkbox"/> FAC-Neutral Test (D5)
<input type="checkbox"/> Salt Crust (B11)	
<input type="checkbox"/> Biotic Crust (B12)	
<input type="checkbox"/> Aquatic Invertebrates (B13)	
<input type="checkbox"/> Hydrogen Sulfide Odor (C1)	
<input type="checkbox"/> Oxidized Rhizospheres along Living Roots (C3)	
<input type="checkbox"/> Presence of Reduced Iron (C4)	
<input type="checkbox"/> Recent Iron Reduction in Tilled Soils (C6)	
<input type="checkbox"/> Thin Muck Surface (C7)	
<input type="checkbox"/> Other (Explain in Remarks)	

Field Observations:

Surface Water Present?	Yes _____ No <input checked="" type="checkbox"/>	Depth (inches): _____	Wetland Hydrology Present? Yes <input checked="" type="checkbox"/> No _____
Water Table Present?	Yes _____ No <input checked="" type="checkbox"/>	Depth (inches): _____	
Saturation Present? (includes capillary fringe)	Yes _____ No <input checked="" type="checkbox"/>	Depth (inches): _____	
Describe Recorded Data (stream gauge, monitoring well, aerial photos, previous inspections), if available:			

Remarks:
Soil moist at 7" depth.

WETLAND DETERMINATION DATA FORM – Arid West Region

Project/Site: Vega SES 4 City/County: Holtville/ Imperial County Sampling Date: 11/5/2020
 Applicant/Owner: zGlobal, Inc. State: CA Sampling Point: 14
 Investigator(s): C. Congedo Section, Township, Range: S10, T17S, R16E
 Landform (hillslope, terrace, etc.): Depression Local relief (concave, convex, none): Concave Slope (%): 3
 Subregion (LRR): D Lat: 32.683739 Long: -115.311776 Datum: NAD83
 Soil Map Unit Name: Rositas fine sand, wet, 0 to 2 percent slopes NWI classification: N/A

Are climatic / hydrologic conditions on the site typical for this time of year? Yes No (If no, explain in Remarks.)
 Are Vegetation , Soil , or Hydrology significantly disturbed? Are "Normal Circumstances" present? Yes No
 Are Vegetation , Soil , or Hydrology naturally problematic? (If needed, explain any answers in Remarks.)

SUMMARY OF FINDINGS – Attach site map showing sampling point locations, transects, important features, etc.

Hydrophytic Vegetation Present? Yes <input checked="" type="checkbox"/> No <input type="checkbox"/> Hydric Soil Present? Yes <input checked="" type="checkbox"/> No <input type="checkbox"/> Wetland Hydrology Present? Yes <input checked="" type="checkbox"/> No <input type="checkbox"/>	Is the Sampled Area within a Wetland? Yes <input checked="" type="checkbox"/> No <input type="checkbox"/>
Remarks: Point taken within arrow weed thickets, ~90 feet downslope (south) of a hard-packed dirt road that runs parallel to the All-American Canal.	

VEGETATION – Use scientific names of plants.

Tree Stratum (Plot size: <u>20'</u>)	Absolute % Cover	Dominant Species?	Indicator Status	
1. <u>Prosopis pubescens</u>	<u>2</u>		<u>FAC</u>	Dominance Test worksheet: Number of Dominant Species That Are OBL, FACW, or FAC: <u>1</u> (A) Total Number of Dominant Species Across All Strata: <u>1</u> (B) Percent of Dominant Species That Are OBL, FACW, or FAC: <u>100</u> (A/B)
2. <u>Tamarix sp.</u>	<u>2</u>		<u>FAC</u>	
3. _____				
4. _____				
<u>4</u> = Total Cover				Prevalence Index worksheet: Total % Cover of: _____ Multiply by: _____ OBL species <u>0</u> x 1 = <u>0</u> FACW species <u>15</u> x 2 = <u>30</u> FAC species <u>4</u> x 3 = <u>12</u> FACU species <u>0</u> x 4 = <u>0</u> UPL species <u>0</u> x 5 = <u>0</u> Column Totals: <u>19</u> (A) <u>42</u> (B) Prevalence Index = B/A = <u>2.21</u>
Sapling/Shrub Stratum (Plot size: <u>20'</u>)				
1. <u>Pluchea sericea</u>	<u>15</u>	<u>x</u>	<u>FACW</u>	
2. _____				
3. _____				
4. _____				
5. _____				
<u>15</u> = Total Cover				
Herb Stratum (Plot size: _____)				
1. _____				
2. _____				
3. _____				
4. _____				
5. _____				
6. _____				
7. _____				
8. _____				
<u>0</u> = Total Cover				
Woody Vine Stratum (Plot size: _____)				
1. _____				
2. _____				
<u>0</u> = Total Cover				
% Bare Ground in Herb Stratum <u>81</u>		% Cover of Biotic Crust _____		
Hydrophytic Vegetation Indicators: <input checked="" type="checkbox"/> Dominance Test is >50% <input checked="" type="checkbox"/> Prevalence Index is ≤3.0 ¹ <input type="checkbox"/> Morphological Adaptations ¹ (Provide supporting data in Remarks or on a separate sheet) <input type="checkbox"/> Problematic Hydrophytic Vegetation ¹ (Explain)				
¹ Indicators of hydric soil and wetland hydrology must be present, unless disturbed or problematic.				
Hydrophytic Vegetation Present? Yes <input checked="" type="checkbox"/> No <input type="checkbox"/>				
Remarks:				

SOIL

Sampling Point: 14

Profile Description: (Describe to the depth needed to document the indicator or confirm the absence of indicators.)

Depth (inches)	Matrix		Redox Features				Texture	Remarks
	Color (moist)	%	Color (moist)	%	Type ¹	Loc ²		
0-6	7.5YR 4/4	95	5YR 4/6	5	C	PL	loam	
6-14+	10YR 5/3	92	5YR 4/6	8	C	M, PL	Loamy sand	

¹Type: C=Concentration, D=Depletion, RM=Reduced Matrix, CS=Covered or Coated Sand Grains. ²Location: PL=Pore Lining, M=Matrix.

Hydric Soil Indicators: (Applicable to all LRRs, unless otherwise noted.)

- Histosol (A1)
- Histic Epipedon (A2)
- Black Histic (A3)
- Hydrogen Sulfide (A4)
- Stratified Layers (A5) (**LRR C**)
- 1 cm Muck (A9) (**LRR D**)
- Depleted Below Dark Surface (A11)
- Thick Dark Surface (A12)
- Sandy Mucky Mineral (S1)
- Sandy Gleyed Matrix (S4)
- Sandy Redox (S5)
- Stripped Matrix (S6)
- Loamy Mucky Mineral (F1)
- Loamy Gleyed Matrix (F2)
- Depleted Matrix (F3)
- Redox Dark Surface (F6)
- Depleted Dark Surface (F7)
- Redox Depressions (F8)
- Vernal Pools (F9)

Indicators for Problematic Hydric Soils³:

- 1 cm Muck (A9) (**LRR C**)
- 2 cm Muck (A10) (**LRR B**)
- Reduced Vertic (F18)
- Red Parent Material (TF2)
- Other (Explain in Remarks)

³Indicators of hydrophytic vegetation and wetland hydrology must be present, unless disturbed or problematic.

Restrictive Layer (if present):

Type: _____
Depth (inches): _____

Hydric Soil Present? Yes No

Remarks:

Soil moist throughout; organic material in first 4 inches.

HYDROLOGY

Wetland Hydrology Indicators:

Primary Indicators (minimum of one required; check all that apply)

- Surface Water (A1)
- High Water Table (A2)
- Saturation (A3)
- Water Marks (B1) (**Nonriverine**)
- Sediment Deposits (B2) (**Nonriverine**)
- Drift Deposits (B3) (**Nonriverine**)
- Surface Soil Cracks (B6)
- Inundation Visible on Aerial Imagery (B7)
- Water-Stained Leaves (B9)

Secondary Indicators (2 or more required)

- Salt Crust (B11)
- Biotic Crust (B12)
- Aquatic Invertebrates (B13)
- Hydrogen Sulfide Odor (C1)
- Oxidized Rhizospheres along Living Roots (C3)
- Presence of Reduced Iron (C4)
- Recent Iron Reduction in Tilled Soils (C6)
- Thin Muck Surface (C7)
- Other (Explain in Remarks)
- Water Marks (B1) (**Riverine**)
- Sediment Deposits (B2) (**Riverine**)
- Drift Deposits (B3) (**Riverine**)
- Drainage Patterns (B10)
- Dry-Season Water Table (C2)
- Crayfish Burrows (C8)
- Saturation Visible on Aerial Imagery (C9)
- Shallow Aquitard (D3)
- FAC-Neutral Test (D5)

Field Observations:

Surface Water Present? Yes No Depth (inches): _____
 Water Table Present? Yes No Depth (inches): _____
 Saturation Present? (includes capillary fringe) Yes No Depth (inches): _____

Wetland Hydrology Present? Yes No

Describe Recorded Data (stream gauge, monitoring well, aerial photos, previous inspections), if available:

Remarks:

Soil moist.

WETLAND DETERMINATION DATA FORM – Arid West Region

Project/Site: Vega SES 4 City/County: Holtville/ Imperial County Sampling Date: 11/12/2020
 Applicant/Owner: zGlobal, Inc. State: CA Sampling Point: 400
 Investigator(s): C. Congedo, C. Garcia, C. Torres Section, Township, Range: S11, T17S, R16E
 Landform (hillslope, terrace, etc.): Toeslope Local relief (concave, convex, none): Concave Slope (%): 5
 Subregion (LRR): D Lat: 32.690557 Long: -115.294997 Datum: NAD83
 Soil Map Unit Name: Rositas fine sand, wet, 0 to 2 percent slopes NWI classification: N/A

Are climatic / hydrologic conditions on the site typical for this time of year? Yes No (If no, explain in Remarks.)
 Are Vegetation , Soil , or Hydrology significantly disturbed? Are "Normal Circumstances" present? Yes No
 Are Vegetation , Soil , or Hydrology naturally problematic? (If needed, explain any answers in Remarks.)

SUMMARY OF FINDINGS – Attach site map showing sampling point locations, transects, important features, etc.

Hydrophytic Vegetation Present? Yes <input checked="" type="checkbox"/> No <input type="checkbox"/> Hydric Soil Present? Yes <input type="checkbox"/> No <input checked="" type="checkbox"/> Wetland Hydrology Present? Yes <input checked="" type="checkbox"/> No <input type="checkbox"/>	Is the Sampled Area within a Wetland? Yes <input checked="" type="checkbox"/> No <input type="checkbox"/>
Remarks: Point taken within a previously disturbed riparian area, downslope (south) of a hard-packed dirt road that runs parallel to the All-American Canal. An adjacent graded road exists approximately 10 feet south of sample point.	

VEGETATION – Use scientific names of plants.

Tree Stratum (Plot size: <u>15'</u>)	Absolute % Cover	Dominant Species?	Indicator Status	
1. <u>Tamarix sp.</u>	<u>20</u>	<u>x</u>	<u>FAC</u>	Dominance Test worksheet: Number of Dominant Species That Are OBL, FACW, or FAC: <u>2</u> (A) Total Number of Dominant Species Across All Strata: <u>2</u> (B) Percent of Dominant Species That Are OBL, FACW, or FAC: <u>100</u> (A/B)
2. _____	_____	_____	_____	
3. _____	_____	_____	_____	
4. _____	_____	_____	_____	
<u>20</u> = Total Cover				
Sapling/Shrub Stratum (Plot size: <u>15'</u>)	Absolute % Cover	Dominant Species?	Indicator Status	
1. <u>Typha sp.</u>	<u>10</u>	<u>x</u>	<u>OBL</u>	Prevalence Index worksheet: Total % Cover of: _____ Multiply by: _____ OBL species <u>10</u> x 1 = <u>10</u> FACW species <u>5</u> x 2 = <u>10</u> FAC species <u>20</u> x 3 = <u>60</u> FACU species <u>0</u> x 4 = <u>0</u> UPL species <u>0</u> x 5 = <u>0</u> Column Totals: <u>35</u> (A) <u>80</u> (B) Prevalence Index = B/A = <u>2.29</u>
2. <u>Pluchea sericea</u>	<u>5</u>	_____	<u>FACW</u>	
3. _____	_____	_____	_____	
4. _____	_____	_____	_____	
5. _____	_____	_____	_____	
<u>15</u> = Total Cover				
Herb Stratum (Plot size: _____)	Absolute % Cover	Dominant Species?	Indicator Status	
1. _____	_____	_____	_____	Hydrophytic Vegetation Indicators: <input checked="" type="checkbox"/> Dominance Test is >50% <input checked="" type="checkbox"/> Prevalence Index is ≤3.0 ¹ <input type="checkbox"/> Morphological Adaptations ¹ (Provide supporting data in Remarks or on a separate sheet) <input type="checkbox"/> Problematic Hydrophytic Vegetation ¹ (Explain) ¹ Indicators of hydric soil and wetland hydrology must be present, unless disturbed or problematic.
2. _____	_____	_____	_____	
3. _____	_____	_____	_____	
4. _____	_____	_____	_____	
5. _____	_____	_____	_____	
6. _____	_____	_____	_____	
7. _____	_____	_____	_____	
8. _____	_____	_____	_____	
<u>0</u> = Total Cover				
Woody Vine Stratum (Plot size: _____)	Absolute % Cover	Dominant Species?	Indicator Status	
1. _____	_____	_____	_____	Hydrophytic Vegetation Present? Yes <input checked="" type="checkbox"/> No <input type="checkbox"/>
2. _____	_____	_____	_____	
<u>0</u> = Total Cover				
% Bare Ground in Herb Stratum <u>65</u> % Cover of Biotic Crust _____				

Remarks:

SOIL

Sampling Point: 400

Profile Description: (Describe to the depth needed to document the indicator or confirm the absence of indicators.)

Depth (inches)	Matrix		Redox Features				Texture	Remarks
	Color (moist)	%	Color (moist)	%	Type ¹	Loc ²		
0-3	7.5YR 4/3	80	10YR 7/4	20	C	M	Loam	
3-5	Gley 1, 2.5/N	90	Gley 1, 6/10Y	10			Loam	
5-7	10YR 4/1	100					Sandy clay	
7-13	10YR 4/1	100					Loamy sand	

¹Type: C=Concentration, D=Depletion, RM=Reduced Matrix, CS=Covered or Coated Sand Grains. ²Location: PL=Pore Lining, M=Matrix.

Hydric Soil Indicators: (Applicable to all LRRs, unless otherwise noted.)

- Histosol (A1)
- Histic Epipedon (A2)
- Black Histic (A3)
- Hydrogen Sulfide (A4)
- Stratified Layers (A5) **(LRR C)**
- 1 cm Muck (A9) **(LRR D)**
- Depleted Below Dark Surface (A11)
- Thick Dark Surface (A12)
- Sandy Mucky Mineral (S1)
- Sandy Gleyed Matrix (S4)

- Sandy Redox (S5)
- Stripped Matrix (S6)
- Loamy Mucky Mineral (F1)
- Loamy Gleyed Matrix (F2)
- Depleted Matrix (F3)
- Redox Dark Surface (F6)
- Depleted Dark Surface (F7)
- Redox Depressions (F8)
- Vernal Pools (F9)

Indicators for Problematic Hydric Soils³:

- 1 cm Muck (A9) **(LRR C)**
- 2 cm Muck (A10) **(LRR B)**
- Reduced Vertic (F18)
- Red Parent Material (TF2)
- Other (Explain in Remarks)

³Indicators of hydrophytic vegetation and wetland hydrology must be present, unless disturbed or problematic.

Restrictive Layer (if present):

Type: _____
 Depth (inches): _____

Hydric Soil Present? Yes _____ No

Remarks:

HYDROLOGY

Wetland Hydrology Indicators:

Primary Indicators (minimum of one required; check all that apply)

- Surface Water (A1)
- High Water Table (A2)
- Saturation (A3)
- Water Marks (B1) **(Nonriverine)**
- Sediment Deposits (B2) **(Nonriverine)**
- Drift Deposits (B3) **(Nonriverine)**
- Surface Soil Cracks (B6)
- Inundation Visible on Aerial Imagery (B7)
- Water-Stained Leaves (B9)

- Salt Crust (B11)
- Biotic Crust (B12)
- Aquatic Invertebrates (B13)
- Hydrogen Sulfide Odor (C1)
- Oxidized Rhizospheres along Living Roots (C3)
- Presence of Reduced Iron (C4)
- Recent Iron Reduction in Tilled Soils (C6)
- Thin Muck Surface (C7)
- Other (Explain in Remarks)

Secondary Indicators (2 or more required)

- Water Marks (B1) **(Riverine)**
- Sediment Deposits (B2) **(Riverine)**
- Drift Deposits (B3) **(Riverine)**
- Drainage Patterns (B10)
- Dry-Season Water Table (C2)
- Crayfish Burrows (C8)
- Saturation Visible on Aerial Imagery (C9)
- Shallow Aquitard (D3)
- FAC-Neutral Test (D5)

Field Observations:

Surface Water Present? Yes _____ No Depth (inches): _____
 Water Table Present? Yes No _____ Depth (inches): 10
 Saturation Present? Yes No _____ Depth (inches): 1
 (includes capillary fringe)

Wetland Hydrology Present? Yes No _____

Describe Recorded Data (stream gauge, monitoring well, aerial photos, previous inspections), if available:

Remarks:

WETLAND DETERMINATION DATA FORM – Arid West Region

Project/Site: Vega SES 4 City/County: Holtville/ Imperial County Sampling Date: 11/12/2020
 Applicant/Owner: zGlobal, Inc. State: CA Sampling Point: 401
 Investigator(s): C. Congedo, C. Garcia, C. Torres Section, Township, Range: S10, T17S, R16E
 Landform (hillslope, terrace, etc.): Depression Local relief (concave, convex, none): Concave Slope (%): 10
 Subregion (LRR): D Lat: 32.680346 Long: -115.315672 Datum: NAD83
 Soil Map Unit Name: Vint loamy very fine sand, wet NWI classification: N/A

Are climatic / hydrologic conditions on the site typical for this time of year? Yes No (If no, explain in Remarks.)
 Are Vegetation , Soil , or Hydrology significantly disturbed? Are "Normal Circumstances" present? Yes No
 Are Vegetation , Soil , or Hydrology naturally problematic? (If needed, explain any answers in Remarks.)

SUMMARY OF FINDINGS – Attach site map showing sampling point locations, transects, important features, etc.

Hydrophytic Vegetation Present? Yes <input checked="" type="checkbox"/> No <input type="checkbox"/> Hydric Soil Present? Yes <input checked="" type="checkbox"/> No <input type="checkbox"/> Wetland Hydrology Present? Yes <input checked="" type="checkbox"/> No <input type="checkbox"/>	Is the Sampled Area within a Wetland? Yes <input checked="" type="checkbox"/> No <input type="checkbox"/>
Remarks: Point taken within tamarisk thickets, ~850 feet downslope (south) of a hard-packed dirt road that runs parallel to the All-American Canal.	

VEGETATION – Use scientific names of plants.

Tree Stratum (Plot size: <u>20'</u>)	Absolute % Cover	Dominant Species?	Indicator Status	
1. <u>Tamarix sp.</u>	<u>10</u>	<u>x</u>	<u>FAC</u>	Dominance Test worksheet: Number of Dominant Species That Are OBL, FACW, or FAC: <u>1</u> (A) Total Number of Dominant Species Across All Strata: <u>1</u> (B) Percent of Dominant Species That Are OBL, FACW, or FAC: <u>100</u> (A/B)
2. _____	_____	_____	_____	
3. _____	_____	_____	_____	
4. _____	_____	_____	_____	
<u>10</u> = Total Cover				
Sapling/Shrub Stratum (Plot size: <u>20'</u>)	Absolute % Cover	Dominant Species?	Indicator Status	
1. <u>Pluchea sericea</u>	<u>3</u>	_____	<u>FACW</u>	Prevalence Index worksheet: Total % Cover of: _____ Multiply by: _____ OBL species <u>0</u> x 1 = <u>0</u> FACW species <u>3</u> x 2 = <u>6</u> FAC species <u>10</u> x 3 = <u>30</u> FACU species <u>0</u> x 4 = <u>0</u> UPL species <u>0</u> x 5 = <u>0</u> Column Totals: <u>13</u> (A) <u>36</u> (B) Prevalence Index = B/A = <u>2.77</u>
2. _____	_____	_____	_____	
3. _____	_____	_____	_____	
4. _____	_____	_____	_____	
5. _____	_____	_____	_____	
<u>3</u> = Total Cover				
Herb Stratum (Plot size: _____)	Absolute % Cover	Dominant Species?	Indicator Status	
1. _____	_____	_____	_____	Hydrophytic Vegetation Indicators: <input checked="" type="checkbox"/> Dominance Test is >50% <input checked="" type="checkbox"/> Prevalence Index is ≤3.0 ¹ <input type="checkbox"/> Morphological Adaptations ¹ (Provide supporting data in Remarks or on a separate sheet) <input type="checkbox"/> Problematic Hydrophytic Vegetation ¹ (Explain) ¹ Indicators of hydric soil and wetland hydrology must be present, unless disturbed or problematic.
2. _____	_____	_____	_____	
3. _____	_____	_____	_____	
4. _____	_____	_____	_____	
5. _____	_____	_____	_____	
6. _____	_____	_____	_____	
7. _____	_____	_____	_____	
8. _____	_____	_____	_____	
<u>0</u> = Total Cover				
Woody Vine Stratum (Plot size: _____)	Absolute % Cover	Dominant Species?	Indicator Status	
1. _____	_____	_____	_____	Hydrophytic Vegetation Present? Yes <input checked="" type="checkbox"/> No <input type="checkbox"/>
2. _____	_____	_____	_____	
<u>0</u> = Total Cover				
% Bare Ground in Herb Stratum <u>87</u> % Cover of Biotic Crust _____				

Remarks:

SOIL

Sampling Point: 401

Profile Description: (Describe to the depth needed to document the indicator or confirm the absence of indicators.)								
Depth (inches)	Matrix		Redox Features				Texture	Remarks
	Color (moist)	%	Color (moist)	%	Type ¹	Loc ²		
0-2	10YR 2/1	100					Silty clay ^h	Organic layer
2-7	7.5YR 4/4	100					Silt loam	
7-10	7.5YR 4/3	99	5YR 5/8	1	C	PL	Silt loam	
10-13+	7.5YR 4/6	85	5YR 5/8	5	C	M	Silt loam	
	Gley 1, 2.5/N	10						
¹ Type: C=Concentration, D=Depletion, RM=Reduced Matrix, CS=Covered or Coated Sand Grains. ² Location: PL=Pore Lining, M=Matrix.								
Hydric Soil Indicators: (Applicable to all LRRs, unless otherwise noted.)						Indicators for Problematic Hydric Soils³:		
<input type="checkbox"/> Histosol (A1)			<input type="checkbox"/> Sandy Redox (S5)			<input type="checkbox"/> 1 cm Muck (A9) (LRR C)		
<input type="checkbox"/> Histic Epipedon (A2)			<input type="checkbox"/> Stripped Matrix (S6)			<input type="checkbox"/> 2 cm Muck (A10) (LRR B)		
<input type="checkbox"/> Black Histic (A3)			<input type="checkbox"/> Loamy Mucky Mineral (F1)			<input type="checkbox"/> Reduced Vertic (F18)		
<input type="checkbox"/> Hydrogen Sulfide (A4)			<input type="checkbox"/> Loamy Gleyed Matrix (F2)			<input type="checkbox"/> Red Parent Material (TF2)		
<input type="checkbox"/> Stratified Layers (A5) (LRR C)			<input type="checkbox"/> Depleted Matrix (F3)			<input type="checkbox"/> Other (Explain in Remarks)		
<input type="checkbox"/> 1 cm Muck (A9) (LRR D)			<input type="checkbox"/> Redox Dark Surface (F6)			³ Indicators of hydrophytic vegetation and wetland hydrology must be present, unless disturbed or problematic.		
<input checked="" type="checkbox"/> Depleted Below Dark Surface (A11)			<input type="checkbox"/> Depleted Dark Surface (F7)					
<input type="checkbox"/> Thick Dark Surface (A12)			<input type="checkbox"/> Redox Depressions (F8)					
<input type="checkbox"/> Sandy Mucky Mineral (S1)			<input type="checkbox"/> Vernal Pools (F9)					
<input type="checkbox"/> Sandy Gleyed Matrix (S4)								
Restrictive Layer (if present):						Hydric Soil Present? Yes <input checked="" type="checkbox"/> No <input type="checkbox"/>		
Type: _____								
Depth (inches): _____								
Remarks:								

HYDROLOGY

Wetland Hydrology Indicators:		
Primary Indicators (minimum of one required; check all that apply)	Secondary Indicators (2 or more required)	
<input type="checkbox"/> Surface Water (A1)	<input type="checkbox"/> Salt Crust (B11)	<input type="checkbox"/> Water Marks (B1) (Riverine)
<input type="checkbox"/> High Water Table (A2)	<input type="checkbox"/> Biotic Crust (B12)	<input type="checkbox"/> Sediment Deposits (B2) (Riverine)
<input type="checkbox"/> Saturation (A3)	<input type="checkbox"/> Aquatic Invertebrates (B13)	<input type="checkbox"/> Drift Deposits (B3) (Riverine)
<input type="checkbox"/> Water Marks (B1) (Nonriverine)	<input type="checkbox"/> Hydrogen Sulfide Odor (C1)	<input type="checkbox"/> Drainage Patterns (B10)
<input type="checkbox"/> Sediment Deposits (B2) (Nonriverine)	<input type="checkbox"/> Oxidized Rhizospheres along Living Roots (C3)	<input type="checkbox"/> Dry-Season Water Table (C2)
<input type="checkbox"/> Drift Deposits (B3) (Nonriverine)	<input type="checkbox"/> Presence of Reduced Iron (C4)	<input type="checkbox"/> Crayfish Burrows (C8)
<input checked="" type="checkbox"/> Surface Soil Cracks (B6)	<input type="checkbox"/> Recent Iron Reduction in Tilled Soils (C6)	<input type="checkbox"/> Saturation Visible on Aerial Imagery (C9)
<input type="checkbox"/> Inundation Visible on Aerial Imagery (B7)	<input type="checkbox"/> Thin Muck Surface (C7)	<input type="checkbox"/> Shallow Aquitard (D3)
<input type="checkbox"/> Water-Stained Leaves (B9)	<input type="checkbox"/> Other (Explain in Remarks)	<input type="checkbox"/> FAC-Neutral Test (D5)
Field Observations:		
Surface Water Present? Yes <input type="checkbox"/> No <input checked="" type="checkbox"/>	Depth (inches): _____	Wetland Hydrology Present? Yes <input checked="" type="checkbox"/> No <input type="checkbox"/>
Water Table Present? Yes <input type="checkbox"/> No <input checked="" type="checkbox"/>	Depth (inches): _____	
Saturation Present? Yes <input type="checkbox"/> No <input checked="" type="checkbox"/>	Depth (inches): _____	
(includes capillary fringe)		
Describe Recorded Data (stream gauge, monitoring well, aerial photos, previous inspections), if available:		
Remarks:		
Salt crust, but appears to be from agricultural runoff.		

WETLAND DETERMINATION DATA FORM – Arid West Region

Project/Site: Vega SES 4 City/County: Holtville/ Imperial County Sampling Date: 11/12/2020
 Applicant/Owner: zGlobal, Inc. State: CA Sampling Point: 402
 Investigator(s): C. Congedo, C. Garcia, C. Torres Section, Township, Range: S10, T17S, R16E
 Landform (hillslope, terrace, etc.): Depression Local relief (concave, convex, none): Concave Slope (%): 10
 Subregion (LRR): D Lat: 32.682005 Long: -115.316274 Datum: NAD83
 Soil Map Unit Name: Rositas sand, 2 to 5 percent slopes NWI classification: N/A

Are climatic / hydrologic conditions on the site typical for this time of year? Yes No (If no, explain in Remarks.)
 Are Vegetation , Soil , or Hydrology significantly disturbed? Are "Normal Circumstances" present? Yes No
 Are Vegetation , Soil , or Hydrology naturally problematic? (If needed, explain any answers in Remarks.)

SUMMARY OF FINDINGS – Attach site map showing sampling point locations, transects, important features, etc.

Hydrophytic Vegetation Present? Yes <input checked="" type="checkbox"/> No <input type="checkbox"/> Hydric Soil Present? Yes <input checked="" type="checkbox"/> No <input type="checkbox"/> Wetland Hydrology Present? Yes <input checked="" type="checkbox"/> No <input type="checkbox"/>	Is the Sampled Area within a Wetland? Yes <input checked="" type="checkbox"/> No <input type="checkbox"/>
Remarks: Point taken within tamarisk thickets, downslope (south) of a hard-packed dirt road that runs parallel to the All-American Canal.	

VEGETATION – Use scientific names of plants.

Tree Stratum (Plot size: <u>15'</u>)	Absolute % Cover	Dominant Species?	Indicator Status	
1. <u>Tamarix sp.</u>	<u>20</u>	<u>x</u>	<u>FAC</u>	Dominance Test worksheet: Number of Dominant Species That Are OBL, FACW, or FAC: <u>2</u> (A) Total Number of Dominant Species Across All Strata: <u>2</u> (B) Percent of Dominant Species That Are OBL, FACW, or FAC: <u>100</u> (A/B)
2. _____	_____	_____	_____	
3. _____	_____	_____	_____	
4. _____	_____	_____	_____	
<u>20</u> = Total Cover				
Sapling/Shrub Stratum (Plot size: <u>15'</u>)				
1. <u>Baccharis salicina</u>	<u>1</u>	_____	<u>FACW</u>	Prevalence Index worksheet: Total % Cover of: _____ Multiply by: _____ OBL species <u>0</u> x 1 = <u>0</u> FACW species <u>36</u> x 2 = <u>72</u> FAC species <u>20</u> x 3 = <u>60</u> FACU species <u>0</u> x 4 = <u>0</u> UPL species <u>0</u> x 5 = <u>0</u> Column Totals: <u>56</u> (A) <u>132</u> (B) Prevalence Index = B/A = <u>2.36</u>
2. <u>Pluchea sericea</u>	<u>35</u>	<u>x</u>	<u>FACW</u>	
3. _____	_____	_____	_____	
4. _____	_____	_____	_____	
5. _____	_____	_____	_____	
<u>36</u> = Total Cover				
Herb Stratum (Plot size: _____)				
1. _____	_____	_____	_____	Hydrophytic Vegetation Indicators: <input checked="" type="checkbox"/> Dominance Test is >50% <input checked="" type="checkbox"/> Prevalence Index is ≤3.0 ¹ <input type="checkbox"/> Morphological Adaptations ¹ (Provide supporting data in Remarks or on a separate sheet) <input type="checkbox"/> Problematic Hydrophytic Vegetation ¹ (Explain)
2. _____	_____	_____	_____	
3. _____	_____	_____	_____	
4. _____	_____	_____	_____	
5. _____	_____	_____	_____	
6. _____	_____	_____	_____	
7. _____	_____	_____	_____	
8. _____	_____	_____	_____	
<u>0</u> = Total Cover				
Woody Vine Stratum (Plot size: _____)				
1. _____	_____	_____	_____	¹ Indicators of hydric soil and wetland hydrology must be present, unless disturbed or problematic.
2. _____	_____	_____	_____	
<u>0</u> = Total Cover				
% Bare Ground in Herb Stratum <u>44</u> % Cover of Biotic Crust _____		Hydrophytic Vegetation Present? Yes <input checked="" type="checkbox"/> No <input type="checkbox"/>		

Remarks:

SOIL

Sampling Point: 402

Profile Description: (Describe to the depth needed to document the indicator or confirm the absence of indicators.)								
Depth (inches)	Matrix		Redox Features				Texture	Remarks
	Color (moist)	%	Color (moist)	%	Type ¹	Loc ²		
0-3	10YR 2/1	100					Silty clay ⁴	
3-13+	10YR 4/4	94	5YR 5/8	5	C	PL, M	Sandy lo ⁴	
3-13+			Gley 1, 2.5/N	1	C	M		
¹ Type: C=Concentration, D=Depletion, RM=Reduced Matrix, CS=Covered or Coated Sand Grains. ² Location: PL=Pore Lining, M=Matrix.								
Hydric Soil Indicators: (Applicable to all LRRs, unless otherwise noted.)						Indicators for Problematic Hydric Soils³:		
<input type="checkbox"/> Histosol (A1)			<input type="checkbox"/> Sandy Redox (S5)			<input type="checkbox"/> 1 cm Muck (A9) (LRR C)		
<input type="checkbox"/> Histic Epipedon (A2)			<input type="checkbox"/> Stripped Matrix (S6)			<input type="checkbox"/> 2 cm Muck (A10) (LRR B)		
<input type="checkbox"/> Black Histic (A3)			<input type="checkbox"/> Loamy Mucky Mineral (F1)			<input type="checkbox"/> Reduced Vertic (F18)		
<input type="checkbox"/> Hydrogen Sulfide (A4)			<input type="checkbox"/> Loamy Gleyed Matrix (F2)			<input type="checkbox"/> Red Parent Material (TF2)		
<input type="checkbox"/> Stratified Layers (A5) (LRR C)			<input type="checkbox"/> Depleted Matrix (F3)			<input type="checkbox"/> Other (Explain in Remarks)		
<input type="checkbox"/> 1 cm Muck (A9) (LRR D)			<input type="checkbox"/> Redox Dark Surface (F6)			³ Indicators of hydrophytic vegetation and wetland hydrology must be present, unless disturbed or problematic.		
<input checked="" type="checkbox"/> Depleted Below Dark Surface (A11)			<input type="checkbox"/> Depleted Dark Surface (F7)					
<input type="checkbox"/> Thick Dark Surface (A12)			<input checked="" type="checkbox"/> Redox Depressions (F8)					
<input type="checkbox"/> Sandy Mucky Mineral (S1)			<input type="checkbox"/> Vernal Pools (F9)					
<input type="checkbox"/> Sandy Gleyed Matrix (S4)								
Restrictive Layer (if present):								
Type: _____								
Depth (inches): _____						Hydric Soil Present? Yes <input checked="" type="checkbox"/> No <input type="checkbox"/>		
Remarks:								

HYDROLOGY

Wetland Hydrology Indicators:					
Primary Indicators (minimum of one required; check all that apply)			Secondary Indicators (2 or more required)		
<input type="checkbox"/> Surface Water (A1)	<input type="checkbox"/> Salt Crust (B11)	<input type="checkbox"/> Water Marks (B1) (Riverine)			
<input type="checkbox"/> High Water Table (A2)	<input type="checkbox"/> Biotic Crust (B12)	<input type="checkbox"/> Sediment Deposits (B2) (Riverine)			
<input checked="" type="checkbox"/> Saturation (A3)	<input type="checkbox"/> Aquatic Invertebrates (B13)	<input type="checkbox"/> Drift Deposits (B3) (Riverine)			
<input type="checkbox"/> Water Marks (B1) (Nonriverine)	<input type="checkbox"/> Hydrogen Sulfide Odor (C1)	<input type="checkbox"/> Drainage Patterns (B10)			
<input type="checkbox"/> Sediment Deposits (B2) (Nonriverine)	<input checked="" type="checkbox"/> Oxidized Rhizospheres along Living Roots (C3)	<input type="checkbox"/> Dry-Season Water Table (C2)			
<input checked="" type="checkbox"/> Drift Deposits (B3) (Nonriverine)	<input type="checkbox"/> Presence of Reduced Iron (C4)	<input type="checkbox"/> Crayfish Burrows (C8)			
<input type="checkbox"/> Surface Soil Cracks (B6)	<input type="checkbox"/> Recent Iron Reduction in Tilled Soils (C6)	<input type="checkbox"/> Saturation Visible on Aerial Imagery (C9)			
<input type="checkbox"/> Inundation Visible on Aerial Imagery (B7)	<input type="checkbox"/> Thin Muck Surface (C7)	<input type="checkbox"/> Shallow Aquitard (D3)			
<input type="checkbox"/> Water-Stained Leaves (B9)	<input type="checkbox"/> Other (Explain in Remarks)	<input type="checkbox"/> FAC-Neutral Test (D5)			
Field Observations:					
Surface Water Present?	Yes <input type="checkbox"/> No <input checked="" type="checkbox"/>	Depth (inches): _____	Wetland Hydrology Present? Yes <input checked="" type="checkbox"/> No <input type="checkbox"/>		
Water Table Present?	Yes <input type="checkbox"/> No <input checked="" type="checkbox"/>	Depth (inches): _____			
Saturation Present? (includes capillary fringe)	Yes <input checked="" type="checkbox"/> No <input type="checkbox"/>	Depth (inches): <u>4</u>			
Describe Recorded Data (stream gauge, monitoring well, aerial photos, previous inspections), if available:					
Remarks:					

WETLAND DETERMINATION DATA FORM – Arid West Region

Project/Site: Vega SES 4 City/County: Holtville/ Imperial County Sampling Date: 11/12/2020
 Applicant/Owner: zGlobal, Inc. State: CA Sampling Point: 403
 Investigator(s): C. Congedo, C. Garcia, C. Torres Section, Township, Range: S10, T17S, R16E
 Landform (hillslope, terrace, etc.): Hillslope Local relief (concave, convex, none): Convex Slope (%): 8
 Subregion (LRR): D Lat: 32.681441 Long: -115.315429 Datum: NAD83
 Soil Map Unit Name: Rositas sand, 2 to 5 percent slopes NWI classification: N/A

Are climatic / hydrologic conditions on the site typical for this time of year? Yes No (If no, explain in Remarks.)
 Are Vegetation , Soil , or Hydrology significantly disturbed? Are "Normal Circumstances" present? Yes No
 Are Vegetation , Soil , or Hydrology naturally problematic? (If needed, explain any answers in Remarks.)

SUMMARY OF FINDINGS – Attach site map showing sampling point locations, transects, important features, etc.

Hydrophytic Vegetation Present? Yes <input type="checkbox"/> No <input checked="" type="checkbox"/> Hydric Soil Present? Yes <input type="checkbox"/> No <input checked="" type="checkbox"/> Wetland Hydrology Present? Yes <input type="checkbox"/> No <input checked="" type="checkbox"/>	Is the Sampled Area within a Wetland? Yes <input type="checkbox"/> No <input checked="" type="checkbox"/>
Remarks: Point taken within creosote bush scrub upslope of tamarisk thickets. A dirt access road exists 60 feet to the east.	

VEGETATION – Use scientific names of plants.

Tree Stratum (Plot size: _____)	Absolute % Cover	Dominant Species?	Indicator Status	
1. _____	_____	_____	_____	Dominance Test worksheet: Number of Dominant Species That Are OBL, FACW, or FAC: <u>1</u> (A) Total Number of Dominant Species Across All Strata: <u>2</u> (B) Percent of Dominant Species That Are OBL, FACW, or FAC: <u>50</u> (A/B)
2. _____	_____	_____	_____	
3. _____	_____	_____	_____	
4. _____	_____	_____	_____	
_____ = Total Cover				Prevalence Index worksheet: Total % Cover of: _____ Multiply by: _____ OBL species <u>0</u> x 1 = <u>0</u> FACW species <u>3</u> x 2 = <u>6</u> FAC species <u>0</u> x 3 = <u>0</u> FACU species <u>0</u> x 4 = <u>0</u> UPL species <u>3</u> x 5 = <u>15</u> Column Totals: <u>6</u> (A) <u>21</u> (B) Prevalence Index = B/A = <u>3.5</u>
Sapling/Shrub Stratum (Plot size: <u>15'</u>)				
1. <u>Larrea tridentata</u>	<u>3</u>	<u>x</u>	<u>N/L</u>	
2. <u>Pluchea sericea</u>	<u>3</u>	<u>x</u>	<u>FACW</u>	
3. _____	_____	_____	_____	
4. _____	_____	_____	_____	
5. _____	_____	_____	_____	
_____ = Total Cover				
Herb Stratum (Plot size: _____)				
1. _____	_____	_____	_____	
2. _____	_____	_____	_____	
3. _____	_____	_____	_____	
4. _____	_____	_____	_____	
5. _____	_____	_____	_____	
6. _____	_____	_____	_____	
7. _____	_____	_____	_____	
8. _____	_____	_____	_____	
_____ = Total Cover				
Woody Vine Stratum (Plot size: _____)				
1. _____	_____	_____	_____	
2. _____	_____	_____	_____	
_____ = Total Cover				
% Bare Ground in Herb Stratum <u>94</u>		% Cover of Biotic Crust _____		

¹Indicators of hydric soil and wetland hydrology must be present, unless disturbed or problematic.

Hydrophytic Vegetation Present? Yes No

Remarks:
 N/L species considered upland.

SOIL

Sampling Point: 403

Profile Description: (Describe to the depth needed to document the indicator or confirm the absence of indicators.)

Depth (inches)	Matrix		Redox Features				Texture	Remarks
	Color (moist)	%	Color (moist)	%	Type ¹	Loc ²		
0-7	10YR 4/4	98	5YR 5/8	1	C	M	Loamy sand	
0-7			7.5YR 9.5/1	1	C	M		
7-12+	10YR 4/4	85	5YR 5/4	5	C	M	Clay loam	
7-12+	10Y 6/4	2	7.5YR 9.5/1	8			Clay loam	

¹Type: C=Concentration, D=Depletion, RM=Reduced Matrix, CS=Covered or Coated Sand Grains. ²Location: PL=Pore Lining, M=Matrix.

Hydric Soil Indicators: (Applicable to all LRRs, unless otherwise noted.)

- Histosol (A1)
- Histic Epipedon (A2)
- Black Histic (A3)
- Hydrogen Sulfide (A4)
- Stratified Layers (A5) **(LRR C)**
- 1 cm Muck (A9) **(LRR D)**
- Depleted Below Dark Surface (A11)
- Thick Dark Surface (A12)
- Sandy Mucky Mineral (S1)
- Sandy Gleyed Matrix (S4)

- Sandy Redox (S5)
- Stripped Matrix (S6)
- Loamy Mucky Mineral (F1)
- Loamy Gleyed Matrix (F2)
- Depleted Matrix (F3)
- Redox Dark Surface (F6)
- Depleted Dark Surface (F7)
- Redox Depressions (F8)
- Vernal Pools (F9)

Indicators for Problematic Hydric Soils³:

- 1 cm Muck (A9) **(LRR C)**
- 2 cm Muck (A10) **(LRR B)**
- Reduced Vertic (F18)
- Red Parent Material (TF2)
- Other (Explain in Remarks)

³Indicators of hydrophytic vegetation and wetland hydrology must be present, unless disturbed or problematic.

Restrictive Layer (if present):

Type: _____
 Depth (inches): _____

Hydric Soil Present? Yes _____ No

Remarks:

HYDROLOGY

Wetland Hydrology Indicators:

Primary Indicators (minimum of one required; check all that apply)	Secondary Indicators (2 or more required)
<input type="checkbox"/> Surface Water (A1)	<input type="checkbox"/> Salt Crust (B11)
<input type="checkbox"/> High Water Table (A2)	<input type="checkbox"/> Biotic Crust (B12)
<input type="checkbox"/> Saturation (A3)	<input type="checkbox"/> Aquatic Invertebrates (B13)
<input type="checkbox"/> Water Marks (B1) (Nonriverine)	<input type="checkbox"/> Hydrogen Sulfide Odor (C1)
<input type="checkbox"/> Sediment Deposits (B2) (Nonriverine)	<input type="checkbox"/> Oxidized Rhizospheres along Living Roots (C3)
<input type="checkbox"/> Drift Deposits (B3) (Nonriverine)	<input type="checkbox"/> Presence of Reduced Iron (C4)
<input type="checkbox"/> Surface Soil Cracks (B6)	<input type="checkbox"/> Recent Iron Reduction in Tilled Soils (C6)
<input type="checkbox"/> Inundation Visible on Aerial Imagery (B7)	<input type="checkbox"/> Thin Muck Surface (C7)
<input type="checkbox"/> Water-Stained Leaves (B9)	<input type="checkbox"/> Other (Explain in Remarks)
	<input type="checkbox"/> Water Marks (B1) (Riverine)
	<input type="checkbox"/> Sediment Deposits (B2) (Riverine)
	<input type="checkbox"/> Drift Deposits (B3) (Riverine)
	<input type="checkbox"/> Drainage Patterns (B10)
	<input type="checkbox"/> Dry-Season Water Table (C2)
	<input type="checkbox"/> Crayfish Burrows (C8)
	<input type="checkbox"/> Saturation Visible on Aerial Imagery (C9)
	<input type="checkbox"/> Shallow Aquitard (D3)
	<input type="checkbox"/> FAC-Neutral Test (D5)

Field Observations:

Surface Water Present? Yes _____ No _____ Depth (inches): _____
 Water Table Present? Yes _____ No _____ Depth (inches): _____
 Saturation Present? Yes _____ No _____ Depth (inches): _____
 (includes capillary fringe)

Wetland Hydrology Present? Yes _____ No

Describe Recorded Data (stream gauge, monitoring well, aerial photos, previous inspections), if available:

Remarks:

WETLAND DETERMINATION DATA FORM – Arid West Region

Project/Site: Vega SES 4 City/County: Holtville/ Imperial County Sampling Date: 11/12/2020
 Applicant/Owner: zGlobal, Inc. State: _____ Sampling Point: 404
 Investigator(s): C. Congedo, C. Garcia, C. Torres Section, Township, Range: S15, T17S, R16E
 Landform (hillslope, terrace, etc.): Slope Local relief (concave, convex, none): Concave Slope (%): 5
 Subregion (LRR): D Lat: 32.679516 Long: -115.318349 Datum: NAD83
 Soil Map Unit Name: Badland NWI classification: N/A

Are climatic / hydrologic conditions on the site typical for this time of year? Yes No _____ (If no, explain in Remarks.)
 Are Vegetation _____, Soil _____, or Hydrology _____ significantly disturbed? Are "Normal Circumstances" present? Yes No _____
 Are Vegetation _____, Soil _____, or Hydrology _____ naturally problematic? (If needed, explain any answers in Remarks.)

SUMMARY OF FINDINGS – Attach site map showing sampling point locations, transects, important features, etc.

Hydrophytic Vegetation Present? Yes <input checked="" type="checkbox"/> No _____ Hydric Soil Present? Yes <input checked="" type="checkbox"/> No _____ Wetland Hydrology Present? Yes <input checked="" type="checkbox"/> No _____	Is the Sampled Area within a Wetland? Yes <input checked="" type="checkbox"/> No _____
Remarks: Point taken within a relatively flat area in alkali weed- salt grass playas and sinks habitat.	

VEGETATION – Use scientific names of plants.

Tree Stratum (Plot size: <u>20'</u>)	Absolute % Cover	Dominant Species?	Indicator Status	
1. <u>Tamarix sp.</u>	<u>2</u>		<u>FAC</u>	Dominance Test worksheet: Number of Dominant Species That Are OBL, FACW, or FAC: <u>1</u> (A) Total Number of Dominant Species Across All Strata: <u>1</u> (B) Percent of Dominant Species That Are OBL, FACW, or FAC: <u>100</u> (A/B)
2. _____				
3. _____				
4. _____				
	<u>2</u>	= Total Cover		
Sapling/Shrub Stratum (Plot size: <u>20'</u>)				Prevalence Index worksheet: Total % Cover of: _____ Multiply by: _____ OBL species <u>0</u> x 1 = <u>0</u> FACW species <u>5</u> x 2 = <u>10</u> FAC species <u>2</u> x 3 = <u>6</u> FACU species <u>0</u> x 4 = <u>0</u> UPL species <u>0</u> x 5 = <u>0</u> Column Totals: <u>7</u> (A) <u>16</u> (B) Prevalence Index = B/A = <u>2.29</u>
1. <u>Pluchea sericea</u>	<u>5</u>	<u>x</u>	<u>FACW</u>	
2. _____				
3. _____				
4. _____				
	<u>5</u>	= Total Cover		
Herb Stratum (Plot size: _____)				Hydrophytic Vegetation Indicators: <input checked="" type="checkbox"/> Dominance Test is >50% <input checked="" type="checkbox"/> Prevalence Index is ≤3.0 ¹ <input type="checkbox"/> Morphological Adaptations ¹ (Provide supporting data in Remarks or on a separate sheet) <input type="checkbox"/> Problematic Hydrophytic Vegetation ¹ (Explain) ¹ Indicators of hydric soil and wetland hydrology must be present, unless disturbed or problematic.
1. _____				
2. _____				
3. _____				
4. _____				
5. _____				
6. _____				
7. _____				
8. _____				
	<u>0</u>	= Total Cover		
Woody Vine Stratum (Plot size: _____)				
1. _____				
2. _____				
	<u>0</u>	= Total Cover		
% Bare Ground in Herb Stratum <u>93</u>		% Cover of Biotic Crust _____		
Remarks:				

SOIL

Sampling Point: 404

Profile Description: (Describe to the depth needed to document the indicator or confirm the absence of indicators.)

Depth (inches)	Matrix		Redox Features				Texture	Remarks
	Color (moist)	%	Color (moist)	%	Type ¹	Loc ²		
0-1	10YR 3/3	100					Silt loam	
1-3	10YR 2/1	100					Loam	
3-4	7.5YR 4/3	99	7.5YR 8/2	1	C	M	Silty clay	
4-12+	10YR 8/2	5	White pg, 9.5/N	15	C	M	Clay	
4-12+	7.5YR 4/4	75	5YR 5/8	5	C	M	Clay	

¹Type: C=Concentration, D=Depletion, RM=Reduced Matrix, CS=Covered or Coated Sand Grains. ²Location: PL=Pore Lining, M=Matrix.

Hydric Soil Indicators: (Applicable to all LRRs, unless otherwise noted.)		Indicators for Problematic Hydric Soils ³ :
<input type="checkbox"/> Histosol (A1)	<input type="checkbox"/> Sandy Redox (S5)	<input type="checkbox"/> 1 cm Muck (A9) (LRR C)
<input type="checkbox"/> Histic Epipedon (A2)	<input type="checkbox"/> Stripped Matrix (S6)	<input type="checkbox"/> 2 cm Muck (A10) (LRR B)
<input type="checkbox"/> Black Histic (A3)	<input type="checkbox"/> Loamy Mucky Mineral (F1)	<input type="checkbox"/> Reduced Vertic (F18)
<input type="checkbox"/> Hydrogen Sulfide (A4)	<input type="checkbox"/> Loamy Gleyed Matrix (F2)	<input type="checkbox"/> Red Parent Material (TF2)
<input type="checkbox"/> Stratified Layers (A5) (LRR C)	<input checked="" type="checkbox"/> Depleted Matrix (F3)	<input type="checkbox"/> Other (Explain in Remarks)
<input type="checkbox"/> 1 cm Muck (A9) (LRR D)	<input type="checkbox"/> Redox Dark Surface (F6)	
<input type="checkbox"/> Depleted Below Dark Surface (A11)	<input type="checkbox"/> Depleted Dark Surface (F7)	
<input type="checkbox"/> Thick Dark Surface (A12)	<input checked="" type="checkbox"/> Redox Depressions (F8)	
<input type="checkbox"/> Sandy Mucky Mineral (S1)	<input type="checkbox"/> Vernal Pools (F9)	
<input type="checkbox"/> Sandy Gleyed Matrix (S4)		

³Indicators of hydrophytic vegetation and wetland hydrology must be present, unless disturbed or problematic.

Restrictive Layer (if present):
 Type: _____
 Depth (inches): _____

Hydric Soil Present? Yes No

Remarks:

HYDROLOGY

Wetland Hydrology Indicators:

Primary Indicators (minimum of one required; check all that apply)	Secondary Indicators (2 or more required)
<input type="checkbox"/> Surface Water (A1)	<input type="checkbox"/> Salt Crust (B11)
<input type="checkbox"/> High Water Table (A2)	<input type="checkbox"/> Biotic Crust (B12)
<input type="checkbox"/> Saturation (A3)	<input type="checkbox"/> Aquatic Invertebrates (B13)
<input type="checkbox"/> Water Marks (B1) (Nonriverine)	<input type="checkbox"/> Hydrogen Sulfide Odor (C1)
<input type="checkbox"/> Sediment Deposits (B2) (Nonriverine)	<input type="checkbox"/> Oxidized Rhizospheres along Living Roots (C3)
<input type="checkbox"/> Drift Deposits (B3) (Nonriverine)	<input type="checkbox"/> Presence of Reduced Iron (C4)
<input checked="" type="checkbox"/> Surface Soil Cracks (B6)	<input type="checkbox"/> Recent Iron Reduction in Tilled Soils (C6)
<input type="checkbox"/> Inundation Visible on Aerial Imagery (B7)	<input type="checkbox"/> Thin Muck Surface (C7)
<input type="checkbox"/> Water-Stained Leaves (B9)	<input type="checkbox"/> Other (Explain in Remarks)
	<input type="checkbox"/> Water Marks (B1) (Riverine)
	<input type="checkbox"/> Sediment Deposits (B2) (Riverine)
	<input type="checkbox"/> Drift Deposits (B3) (Riverine)
	<input checked="" type="checkbox"/> Drainage Patterns (B10)
	<input type="checkbox"/> Dry-Season Water Table (C2)
	<input type="checkbox"/> Crayfish Burrows (C8)
	<input type="checkbox"/> Saturation Visible on Aerial Imagery (C9)
	<input type="checkbox"/> Shallow Aquitard (D3)
	<input type="checkbox"/> FAC-Neutral Test (D5)

Field Observations:

Surface Water Present? Yes No Depth (inches): _____

Water Table Present? Yes No Depth (inches): _____

Saturation Present? (includes capillary fringe) Yes No Depth (inches): _____

Wetland Hydrology Present? Yes No

Describe Recorded Data (stream gauge, monitoring well, aerial photos, previous inspections), if available:

Remarks:

WETLAND DETERMINATION DATA FORM – Arid West Region

Project/Site: Vega SES 4 City/County: Holtville/ Imperial County Sampling Date: 4/13/2022
 Applicant/Owner: zGlobal, Inc. State: CA Sampling Point: 501
 Investigator(s): C. Torres, C. Garcia Section, Township, Range: S11 T17S R18E
 Landform (hillslope, terrace, etc.): Slight slope Local relief (concave, convex, none): None Slope (%): 5
 Subregion (LRR): D Lat: 32.693371 Long: -115.100871 Datum: NAD83
 Soil Map Unit Name: 135: Rositas fine sand, wet, 0 to 2 percent slopes (455524) NWI classification: N/A
 Are climatic / hydrologic conditions on the site typical for this time of year? Yes No (If no, explain in Remarks.)
 Are Vegetation , Soil , or Hydrology significantly disturbed? Are "Normal Circumstances" present? Yes No
 Are Vegetation , Soil , or Hydrology naturally problematic? (If needed, explain any answers in Remarks.)

SUMMARY OF FINDINGS – Attach site map showing sampling point locations, transects, important features, etc.

Hydrophytic Vegetation Present? Yes <input checked="" type="checkbox"/> No <input type="checkbox"/> Hydric Soil Present? Yes <input type="checkbox"/> No <input checked="" type="checkbox"/> Wetland Hydrology Present? Yes <input type="checkbox"/> No <input checked="" type="checkbox"/>	Is the Sampled Area within a Wetland? Yes <input type="checkbox"/> No <input checked="" type="checkbox"/>
Remarks: Sample point taken within tamarisk thickets, in an area that appears to be a remnant wetland due to high amount of dead tamarisk. Likely a remnant finger of what appears to be a currently active wetland (assumption made based on healthy tamarisk present throughout area) located directly northwest of the Study Area.	

VEGETATION – Use scientific names of plants.

Tree Stratum (Plot size: <u>30'</u>)	Absolute % Cover	Dominant Species?	Indicator Status	
1. _____	_____	_____	_____	Dominance Test worksheet: Number of Dominant Species That Are OBL, FACW, or FAC: <u>1</u> (A) Total Number of Dominant Species Across All Strata: <u>1</u> (B) Percent of Dominant Species That Are OBL, FACW, or FAC: <u>100</u> (A/B)
2. _____	_____	_____	_____	
3. _____	_____	_____	_____	
4. _____	_____	_____	_____	
<u>0</u> = Total Cover				Prevalence Index worksheet: Total % Cover of: _____ Multiply by: _____ OBL species <u>0</u> x 1 = <u>0</u> FACW species <u>2</u> x 2 = <u>4</u> FAC species <u>3</u> x 3 = <u>9</u> FACU species <u>1</u> x 4 = <u>4</u> UPL species <u>1</u> x 5 = <u>5</u> Column Totals: <u>7</u> (A) <u>22</u> (B) Prevalence Index = B/A = <u>3.14</u>
Sapling/Shrub Stratum (Plot size: <u>30'</u>)				
1. <u>Tamarix sp.</u>	<u>3</u>	<u>Yes</u>	<u>FAC</u>	
2. <u>Pluchea sericea</u>	<u>2</u>	<u>No</u>	<u>FACW</u>	
3. <u>Larrea tridentata</u>	<u>1</u>	<u>No</u>	<u>N/L</u>	
4. <u>Isocoma acradenia</u>	<u>1</u>	<u>No</u>	<u>FACU</u>	
5. _____	_____	_____	_____	
<u>7</u> = Total Cover				
Herb Stratum (Plot size: <u>30'</u>)				
1. _____	_____	_____	_____	
2. _____	_____	_____	_____	
3. _____	_____	_____	_____	
4. _____	_____	_____	_____	
5. _____	_____	_____	_____	
6. _____	_____	_____	_____	
7. _____	_____	_____	_____	
8. _____	_____	_____	_____	
<u>0</u> = Total Cover				
Woody Vine Stratum (Plot size: <u>30'</u>)				
1. _____	_____	_____	_____	
2. _____	_____	_____	_____	
<u>0</u> = Total Cover				
% Bare Ground in Herb Stratum <u>86</u> % Cover of Biotic Crust <u>0</u>				
Remarks: Dead tamarisk within plot at 7% cover.				
Hydrophytic Vegetation Indicators: <input checked="" type="checkbox"/> Dominance Test is >50% <input type="checkbox"/> Prevalence Index is ≤3.0 ¹ <input type="checkbox"/> Morphological Adaptations ¹ (Provide supporting data in Remarks or on a separate sheet) <input type="checkbox"/> Problematic Hydrophytic Vegetation ¹ (Explain)				
¹ Indicators of hydric soil and wetland hydrology must be present, unless disturbed or problematic.				
Hydrophytic Vegetation Present? Yes <input checked="" type="checkbox"/> No <input type="checkbox"/>				

SOIL

Sampling Point: 501

Profile Description: (Describe to the depth needed to document the indicator or confirm the absence of indicators.)								
Depth (inches)	Matrix		Redox Features				Texture	Remarks
	Color (moist)	%	Color (moist)	%	Type ¹	Loc ²		
0-14+	7.5YR 4/4	100					Snd Lm	

¹Type: C=Concentration, D=Depletion, RM=Reduced Matrix, CS=Covered or Coated Sand Grains. ²Location: PL=Pore Lining, M=Matrix.

Hydric Soil Indicators: (Applicable to all LRRs, unless otherwise noted.)

Indicators for Problematic Hydric Soils³:

- | | | |
|------------------------------------------------------------------|-----------------------------------------------------|-----------------------------------------------------------|
| <input type="checkbox"/> Histosol (A1) | <input type="checkbox"/> Sandy Redox (S5) | <input type="checkbox"/> 1 cm Muck (A9) (LRR C) |
| <input type="checkbox"/> Histic Epipedon (A2) | <input type="checkbox"/> Stripped Matrix (S6) | <input type="checkbox"/> 2 cm Muck (A10) (LRR B) |
| <input type="checkbox"/> Black Histic (A3) | <input type="checkbox"/> Loamy Mucky Mineral (F1) | <input type="checkbox"/> Reduced Vertic (F18) |
| <input type="checkbox"/> Hydrogen Sulfide (A4) | <input type="checkbox"/> Loamy Gleyed Matrix (F2) | <input type="checkbox"/> Red Parent Material (TF2) |
| <input type="checkbox"/> Stratified Layers (A5) (LRR C) | <input type="checkbox"/> Depleted Matrix (F3) | <input type="checkbox"/> Other (Explain in Remarks) |
| <input type="checkbox"/> 1 cm Muck (A9) (LRR D) | <input type="checkbox"/> Redox Dark Surface (F6) | |
| <input type="checkbox"/> Depleted Below Dark Surface (A11) | <input type="checkbox"/> Depleted Dark Surface (F7) | |
| <input type="checkbox"/> Thick Dark Surface (A12) | <input type="checkbox"/> Redox Depressions (F8) | |
| <input type="checkbox"/> Sandy Mucky Mineral (S1) | <input type="checkbox"/> Vernal Pools (F9) | |
| <input type="checkbox"/> Sandy Gleyed Matrix (S4) | | |

³Indicators of hydrophytic vegetation and wetland hydrology must be present, unless disturbed or problematic.

Restrictive Layer (if present):

Type: _____
Depth (inches): _____

Hydric Soil Present? Yes _____ No

Remarks:

HYDROLOGY

Wetland Hydrology Indicators:

Primary Indicators (minimum of one required; check all that apply)	Secondary Indicators (2 or more required)
<input type="checkbox"/> Surface Water (A1)	<input type="checkbox"/> Water Marks (B1) (Riverine)
<input type="checkbox"/> High Water Table (A2)	<input type="checkbox"/> Sediment Deposits (B2) (Riverine)
<input type="checkbox"/> Saturation (A3)	<input type="checkbox"/> Drift Deposits (B3) (Riverine)
<input type="checkbox"/> Water Marks (B1) (Nonriverine)	<input type="checkbox"/> Drainage Patterns (B10)
<input type="checkbox"/> Sediment Deposits (B2) (Nonriverine)	<input type="checkbox"/> Dry-Season Water Table (C2)
<input type="checkbox"/> Drift Deposits (B3) (Nonriverine)	<input type="checkbox"/> Crayfish Burrows (C8)
<input type="checkbox"/> Surface Soil Cracks (B6)	<input type="checkbox"/> Saturation Visible on Aerial Imagery (C9)
<input type="checkbox"/> Inundation Visible on Aerial Imagery (B7)	<input type="checkbox"/> Shallow Aquitard (D3)
<input type="checkbox"/> Water-Stained Leaves (B9)	<input type="checkbox"/> FAC-Neutral Test (D5)
<input type="checkbox"/> Salt Crust (B11)	
<input type="checkbox"/> Biotic Crust (B12)	
<input type="checkbox"/> Aquatic Invertebrates (B13)	
<input type="checkbox"/> Hydrogen Sulfide Odor (C1)	
<input type="checkbox"/> Oxidized Rhizospheres along Living Roots (C3)	
<input type="checkbox"/> Presence of Reduced Iron (C4)	
<input type="checkbox"/> Recent Iron Reduction in Tilled Soils (C6)	
<input type="checkbox"/> Thin Muck Surface (C7)	
<input type="checkbox"/> Other (Explain in Remarks)	

Field Observations:

Surface Water Present? Yes _____ No Depth (inches): _____
 Water Table Present? Yes _____ No Depth (inches): _____
 Saturation Present? (includes capillary fringe) Yes _____ No Depth (inches): _____

Wetland Hydrology Present? Yes _____ No

Describe Recorded Data (stream gauge, monitoring well, aerial photos, previous inspections), if available:

Remarks:

WETLAND DETERMINATION DATA FORM – Arid West Region

Project/Site: Vega SES 4 City/County: Holtville/ Imperial County Sampling Date: 4/13/2022
 Applicant/Owner: zGlobal, Inc. State: CA Sampling Point: 502
 Investigator(s): C. Torres, C. Garcia Section, Township, Range: S10 T17S R18E
 Landform (hillslope, terrace, etc.): Slight slope Local relief (concave, convex, none): None Slope (%): 5
 Subregion (LRR): D Lat: 32.692830 Long: -115.109709 Datum: NAD83
 Soil Map Unit Name: 135: Rositas fine sand, wet, 0 to 2 percent slopes (455524) NWI classification: N/A

Are climatic / hydrologic conditions on the site typical for this time of year? Yes No (If no, explain in Remarks.)
 Are Vegetation , Soil , or Hydrology significantly disturbed? Are "Normal Circumstances" present? Yes No
 Are Vegetation , Soil , or Hydrology naturally problematic? (If needed, explain any answers in Remarks.)

SUMMARY OF FINDINGS – Attach site map showing sampling point locations, transects, important features, etc.

Hydrophytic Vegetation Present? Yes <input type="checkbox"/> No <input checked="" type="checkbox"/> Hydric Soil Present? Yes <input type="checkbox"/> No <input checked="" type="checkbox"/> Wetland Hydrology Present? Yes <input checked="" type="checkbox"/> No <input type="checkbox"/>	Is the Sampled Area within a Wetland? Yes <input type="checkbox"/> No <input checked="" type="checkbox"/>
Remarks: Sample point taken within tamarisk thickets, in an area that appears to be a remnant wetland due to high amount of dead tamarisk. Likely a remnant finger of what appears to be a currently active wetland (assumption made based on healthy tamarisk present throughout area) located directly northwest of the Study Area.	

VEGETATION – Use scientific names of plants.

Tree Stratum (Plot size: <u>30'</u>)	Absolute % Cover	Dominant Species?	Indicator Status	
1. <u>Tamarix sp.</u>	<u>5</u>	<u>Yes</u>	<u>FAC</u>	Dominance Test worksheet: Number of Dominant Species That Are OBL, FACW, or FAC: <u>1</u> (A) Total Number of Dominant Species Across All Strata: <u>2</u> (B) Percent of Dominant Species That Are OBL, FACW, or FAC: <u>50</u> (A/B)
2. _____	_____	_____	_____	
3. _____	_____	_____	_____	
4. _____	_____	_____	_____	
<u>5</u> = Total Cover				
Sapling/Shrub Stratum (Plot size: <u>30'</u>)				
1. <u>Ambrosia dumosa</u>	<u>3</u>	<u>Yes</u>	<u>N/L</u>	Prevalence Index worksheet: Total % Cover of: _____ Multiply by: _____ OBL species <u>0</u> x 1 = <u>0</u> FACW species <u>1</u> x 2 = <u>2</u> FAC species <u>5</u> x 3 = <u>15</u> FACU species <u>0</u> x 4 = <u>0</u> UPL species <u>3</u> x 5 = <u>15</u> Column Totals: <u>9</u> (A) <u>32</u> (B) Prevalence Index = B/A = <u>3.55</u>
2. <u>Pluchea sericea</u>	<u>1</u>	<u>No</u>	<u>FACW</u>	
3. _____	_____	_____	_____	
4. _____	_____	_____	_____	
5. _____	_____	_____	_____	
<u>4</u> = Total Cover				
Herb Stratum (Plot size: <u>30'</u>)				
1. _____	_____	_____	_____	Hydrophytic Vegetation Indicators: <input type="checkbox"/> Dominance Test is >50% <input type="checkbox"/> Prevalence Index is ≤3.0 ¹ <input type="checkbox"/> Morphological Adaptations ¹ (Provide supporting data in Remarks or on a separate sheet) <input type="checkbox"/> Problematic Hydrophytic Vegetation ¹ (Explain)
2. _____	_____	_____	_____	
3. _____	_____	_____	_____	
4. _____	_____	_____	_____	
5. _____	_____	_____	_____	
6. _____	_____	_____	_____	
7. _____	_____	_____	_____	
8. _____	_____	_____	_____	
<u>0</u> = Total Cover				
Woody Vine Stratum (Plot size: <u>30'</u>)				
1. _____	_____	_____	_____	¹ Indicators of hydric soil and wetland hydrology must be present, unless disturbed or problematic.
2. _____	_____	_____	_____	
<u>0</u> = Total Cover				
% Bare Ground in Herb Stratum <u>86</u> % Cover of Biotic Crust <u>0</u>				
Hydrophytic Vegetation Present? Yes <input type="checkbox"/> No <input checked="" type="checkbox"/>				

Remarks:
 Dead tamarisk within plot at 5% cover.

SOIL

Sampling Point: 502

Profile Description: (Describe to the depth needed to document the indicator or confirm the absence of indicators.)

Depth (inches)	Matrix		Redox Features				Texture	Remarks
	Color (moist)	%	Color (moist)	%	Type ¹	Loc ²		
0-14+	7.5YR 4/6	100					Snd Lm	

¹Type: C=Concentration, D=Depletion, RM=Reduced Matrix, CS=Covered or Coated Sand Grains. ²Location: PL=Pore Lining, M=Matrix.

Hydric Soil Indicators: (Applicable to all LRRs, unless otherwise noted.)

- Histosol (A1)
- Histic Epipedon (A2)
- Black Histic (A3)
- Hydrogen Sulfide (A4)
- Stratified Layers (A5) **(LRR C)**
- 1 cm Muck (A9) **(LRR D)**
- Depleted Below Dark Surface (A11)
- Thick Dark Surface (A12)
- Sandy Mucky Mineral (S1)
- Sandy Gleyed Matrix (S4)
- Sandy Redox (S5)
- Stripped Matrix (S6)
- Loamy Mucky Mineral (F1)
- Loamy Gleyed Matrix (F2)
- Depleted Matrix (F3)
- Redox Dark Surface (F6)
- Depleted Dark Surface (F7)
- Redox Depressions (F8)
- Vernal Pools (F9)

Indicators for Problematic Hydric Soils³:

- 1 cm Muck (A9) **(LRR C)**
- 2 cm Muck (A10) **(LRR B)**
- Reduced Vertic (F18)
- Red Parent Material (TF2)
- Other (Explain in Remarks)

³Indicators of hydrophytic vegetation and wetland hydrology must be present, unless disturbed or problematic.

Restrictive Layer (if present):

Type: _____
Depth (inches): _____

Hydric Soil Present? Yes _____ No

Remarks:

HYDROLOGY

Wetland Hydrology Indicators:

Primary Indicators (minimum of one required; check all that apply)

- Surface Water (A1)
- High Water Table (A2)
- Saturation (A3)
- Water Marks (B1) **(Nonriverine)**
- Sediment Deposits (B2) **(Nonriverine)**
- Drift Deposits (B3) **(Nonriverine)**
- Surface Soil Cracks (B6)
- Inundation Visible on Aerial Imagery (B7)
- Water-Stained Leaves (B9)

Secondary Indicators (2 or more required)

- Salt Crust (B11)
- Biotic Crust (B12)
- Aquatic Invertebrates (B13)
- Hydrogen Sulfide Odor (C1)
- Oxidized Rhizospheres along Living Roots (C3)
- Presence of Reduced Iron (C4)
- Recent Iron Reduction in Tilled Soils (C6)
- Thin Muck Surface (C7)
- Other (Explain in Remarks)
- Water Marks (B1) **(Riverine)**
- Sediment Deposits (B2) **(Riverine)**
- Drift Deposits (B3) **(Riverine)**
- Drainage Patterns (B10)
- Dry-Season Water Table (C2)
- Crayfish Burrows (C8)
- Saturation Visible on Aerial Imagery (C9)
- Shallow Aquitard (D3)
- FAC-Neutral Test (D5)

Field Observations:

Surface Water Present? Yes _____ No Depth (inches): _____
 Water Table Present? Yes _____ No Depth (inches): _____
 Saturation Present? Yes _____ No Depth (inches): _____
 (includes capillary fringe)

Wetland Hydrology Present? Yes No _____

Describe Recorded Data (stream gauge, monitoring well, aerial photos, previous inspections), if available:

Remarks:

Representative Site Photographs

Attachment C. Representative Site Photographs



Photo 1. View of the All-American Canal along the northern boundary of the site; photo taken facing west. September 28, 2020.



Photo 2. Vegetation lining the bed of PD-1. Photo taken along northern portion of PD-1, facing northwest. November 5, 2020.

Attachment C. Representative Site Photographs



Photo 3. Soil pit sample for Sampling Point 2 taken within the bed of PD-1. November 4, 2020.



Photo 4. Upstream view of ED-1. Photo taken within northern portion of ED-1, facing northwest. November 5, 2020.

Attachment C. Representative Site Photographs



Photo 5. Downstream view of ED-2. Photo taken within northern portion of ED-2, facing south. November 5, 2020.



Photo 6. Downstream view of ED-3. Photo taken within northern portion of ED-3, facing southeast. November 5, 2020.

Attachment C. Representative Site Photographs



Photo 7. Sample Point 7 taken within the northeastern portion of FSW-3. November 5, 2020.



Photo 8. Sample Point 402 taken within the northeastern portion of FSW-1; photo taken facing southwest. November 5, 2020.

Attachment C. Representative Site Photographs



Photo 9. View of riparian habitat within the Study Area buffer and associated with sample point 501. Due to hydrology and vegetation observed, this area is potentially a remnant wetland. Photo taken facing south. April 12, 2022.



Photo 10. View of the All-American Canal as it flows beneath the access road bridge in the eastern portion of the Study Area. Photo taken facing west. April 12, 2022.

Attachment C. Representative Site Photographs



Photo 11. View of the Off-line Storage Canal as it flows beneath the access road bridge in the eastern portion of the Study Area. Photo taken facing southeast. April 12, 2022.



Photo 12. View of ED-8 within the Study Area buffer and north of the access road. Photo taken facing north. April 13, 2022.

ATTACHMENT D

USACE ORM Aquatic Resources Table
(Provided as an accompanying electronic file)

ATTACHMENT E

Digital Data
(Provided as accompanying electronic files)

**PRELIMINARY GEOLOGICAL AND GEOTECHNICAL
HAZARD EVALUATION REPORT
VEGA 4
Imperial County, California**

June 3, 2021

Prepared for:

**Imperial County
Planning & Development Services Department**

Prepared by:

HDR Engineering, Inc.
3230 El Camino Real, Suite 200
Irvine, CA 92602



PC ORIGINAL PKG

Table of Contents

1.0	Introduction	1-1
1.1	Project Description	1-1
1.2	Site Location and Description.....	1-1
1.3	Purpose and Scope.....	1-1
2.0	Geology, Faulting and Seismicity.....	2-1
2.1	Regional Geologic Setting.....	2-1
2.2	Surface Subgrade soils and Groundwater Conditions.....	2-1
2.3	Faulting.....	2-1
2.4	Historical Seismicity	2-2
3.0	Assessment of Potential Geologic and Geotechnical Hazards	3-1
3.1	Seismic shaking	3-1
3.2	Fault-rupture hazard	3-1
3.3	Flood hazard and Tsunamis	3-1
3.4	Landsliding	3-2
3.5	Liquefaction/Seismic Settlement	3-2
3.6	Lateral spreading.....	3-2
3.7	Land Subsidence.....	3-2
3.8	Expansive soils.....	3-3
3.9	Collapsible soils.....	3-3
3.10	Soil Corrosion.....	3-3
3.11	Other Geologic hazards	3-3
4.0	Preliminary Seismic Design Recommendations.....	4-1
5.0	Conclusions and Limitations	5-1
6.0	References.....	6-1

List of Tables

Table 2-1.	Contributing Faults.....	2-2
Table 2-2.	List of Selected Historic Earthquakes	2-3
Table 4-1.	Preliminary Seismic Design Parameters	4-1

List of Appendices

Appendix A Figures

1.0 INTRODUCTION

1.1 PROJECT DESCRIPTION

It is our understanding that the proposed VEGA 4 Project will consist of the design and construction of a 100-megawatt solar photovoltaic energy facility with an integrated 100-megawatt battery storage system to provide a renewable and reliable source of electrical power. Project components will include ground mounted PV solar power generating system, supporting structures, on-site substation, battery storage system, interconnection facilities, and internal access roads. The project would employ PV power systems to convert solar energy into electricity using non-reflective technology. All proposed improvements will be located on approximately 531 acres of land in south Imperial County, California.

1.2 SITE LOCATION AND DESCRIPTION

The proposed VEGA 4 Project is located approximately 11.5 miles east of Calexico and just north of the United States/Mexico border in Imperial County, California. The Project site consists of three parcels (Parcel Numbers 059-290-010, 059-300-015, and 059-300-017) and is bordered by the All American Canal to the north and United States/Mexico border to the south. The site location is shown on Figure 1, Site Location Map in Appendix A. Based on existing aerial data, the three parcels are unimproved with some minimal vegetation consisting of native small brush, cactus, and grass, to bare ground. Agricultural fields are located north of the All American Canal. A site reconnaissance was not completed for this project due to access restrictions.

The topography of the Project site is relatively flat with elevations ranging from approximately +33 feet at the west to +64 feet at the east. The coordinates at the center of the Project site are approximately:

Latitude: 32.68153°N

Longitude: 115.30894°W

1.3 PURPOSE AND SCOPE

The purpose of this preliminary geological and geotechnical study was to review existing geologic/geotechnical data and evaluate preliminary geological and geotechnical hazards for the proposed Project. This report is preliminary in scope and does not include a subsurface field investigation. A final design report must be performed prior to development after subsurface investigation and laboratory testing has been performed.

Our scope of services for this project included the following tasks:

Literature Review: Reviewed various readily available published and unpublished geologic and geotechnical documents pertinent to the Project site. A list of references used in preparation of this report is presented in Section 6.0.

Preliminary Geologic and Geotechnical Hazards Evaluation: This evaluation included location of known and mapped nearby earthquake faults and seismic zones in relation to the Project site, intensity of ground shaking, potential for liquefaction, ground rupture, landslides, and flooding. Other potential hazards such as expansion, collapse, and corrosivity potentials of on-site soils were also evaluated. Our evaluations were performed based on literature review only. Field and laboratory testing program was not included as a part of our services.

Report Preparation: Relevant geotechnical and geological data were compiled in this report along with our findings and conclusions for the proposed Project.

2.0 GEOLOGY, FAULTING AND SEISMICITY

2.1 REGIONAL GEOLOGIC SETTING

The Project site is located in the Imperial Valley, a part of the Salton Trough, located in the Colorado Desert physiographic province of California. With surface elevations as low as 275 feet below sea level, the Salton Trough formed as a structural depression resulting from tectonic boundary adjustment between the Pacific and the North American plates. The Salton Trough is bounded on the east and northeast by the San Andreas Fault and on the west by the San Jacinto Fault Zone. The structural trough is filled with more than 15,000 feet of Miocene and younger, marine and non-marine sediments capped by approximately 100 feet of Pleistocene and later lacustrine deposits that have been deposited by intermittent filling derived from periodic flooding of the Colorado River and Lake Cahuilla (Morton, 1977). A Regional Geologic Map is shown on Figure 2 (Appendix A).

2.2 SURFACE SUBGRADE SOILS AND GROUNDWATER CONDITIONS

Based on a review of published data by the California Geological Survey (CGS, 2010), the Project site is generally underlain by stratified alluvial deposits, predominately consisting of interbedded layers of silt, sand and clay. According to the Soil Survey of Imperial County prepared by United States Department of Agriculture Soil Conservation Service (2020), the near-surface soils are predominantly comprised of very fine to fine sand and occasionally clay and silty clay. The soil map for the Project site is shown on Figure 3.

A review of online water well databases from USGS (2021b) and California Department of Water Resources (2021) indicate that there are no known water wells within a mile radius from the site. Groundwater information should be obtained after conducting a subsurface field investigation during the design phase of the Project. Seasonal fluctuations of shallow groundwater should be expected during periods of rainfall, irrigation of adjacent properties, and site grading.

2.3 FAULTING

Southern California straddles the boundary between two global tectonic plates known as the North American Plate (on the east) and the Pacific Plate (on the west). The main plate boundary is represented by the San Andreas Fault, which extends northwest from the Gulf of California in Mexico, through the desert region of the Imperial Valley, through the San Bernardino region, and into Northern California, where it eventually trends offshore, north of San Francisco (Jennings and Bryant, 2010).

In Southern California, the plate boundary is a complex system of numerous faults known as the San Andreas Fault System (SAFS) that span a 150-mile-wide zone from the main San Andreas fault in the Imperial Valley westward to offshore of San Diego (Powell et al., 1993 and Wallace, 1990). The major faults east of San Diego (from east to west) include the San Andreas Fault, the San Jacinto fault, and the Elsinore fault. The SAFS is a transform plate boundary dominated by right-lateral fault displacement with the Pacific Plate moving northwest relative to the North American Plate (Wallace, 1990 and Weldon and Sieh, 1985). The significance of this lateral faulting is that transform plate interactions typically generate much smaller maximum magnitude earthquakes than convergent or subduction plate boundaries. Thus, in Southern California the expected maximum moment magnitudes for most faults are typically in the M6.5 to M7.5 range,

with only a few faults (San Andreas Fault, possibly some thrust faults of the Transverse Ranges) capable of generating earthquakes in the M8 range, such as the 1906 San Francisco and 1857 Fort Tejon earthquakes, on the San Andreas Fault itself.

Most of the seismic energy and associated fault displacement within the SAFS occurs along the fault structures closest to the plate boundary (i.e., on the Elsinore, San Jacinto, and San Andreas faults) (Powell et al. 1993). Approximately 1.9 inches/year (49 millimeters per year, [mm/yr.]) of overall lateral displacement have been measured geodetically and as fault slip across the plate boundary. Combined, the Elsinore, San Jacinto, and San Andreas faults account for up to 1.6 inches/year (41 mm/yr.), or 84 percent, of the total plate displacement. The remaining 16 percent is accommodated across the faults to the west (Bennett et al., 1996).

The Project site is located in the seismically active Southern California region, within the influence of several fault systems that are considered to be active or potentially active. Several active or potentially active faults are located in the vicinity of the Project site. The locations of these faults relative to the site are shown on Figure 4, Fault Map (Appendix A).

Under the current understanding of regional seismology and tectonics, the largest maximum earthquake to impact the project may be generated by the Imperial Fault having an estimated maximum magnitude of M7.3. Table 2-1 lists faults with a risk contribution greater than 1 percent, along with pertinent data such as fault type, distance to fault, and maximum magnitude. Other nearby faults are shown in Figure 4.

Table 2-1. Contributing Faults

Fault Name	Distance (km)	Site Location (Latitude and Longitude)	Maximum Magnitude
Imperial Fault [5]	3.8	32.68153°N 115.30894°W	7.3
Imperial Fault [6]	5.9		7.0
Imperial Fault [7]	10.4		6.9

Note:

Listed faults were derived from United States Geologic Survey (USGS) Deaggregation online tool and lists faults with a risk contribution greater than 1 percent of the total seismic risk. Site Class D was assumed and using USGS Dynamic 2014 dataset (V4.2.0) with a 2,475-year return period. See USGS (2021d) for details.

2.4 HISTORICAL SEISMICITY

The Project site and vicinity are located in an area characterized by high seismicity.

The seismicity of the region surrounding the project site was evaluated using the earthquake database from USGS website (2021c). Based on the review of the available data, 206 earthquake events with magnitudes equal or greater than 4.5 have occurred within a radius of 60 miles of the site in the last 100 years. Selected location of the earthquake epicenter, year of occurrence, and earthquake magnitude are summarized in Table 2-2. The earthquakes listed below are based on largest magnitudes.

Table 2-2. List of Selected Historic Earthquakes

Earthquake Location	Date of Earthquake	Earthquake Magnitude
12 km SW of Delta, B.C., MX	04-04-2010	7.2
4 km N of Holtville, CA	05-19-1940	6.9
22 km W of Westmorland, CA	11-24-1987	6.6
5 km NNE of Ocotillo Wells, CA	04-09-1968	6.6
17 km WSW of Westmorland, CA	10-21-1942	6.6
5 km S of Alberto Ovidio Mota, B.C., MX	12-31-1934	6.4
10 km E of Mexicali, B.C., MX	10-15-1979	6.4
24 km SSE of Estacion Coahuila, B.C., MX	12-30-1934	6.3

3.0 ASSESSMENT OF POTENTIAL GEOLOGIC AND GEOTECHNICAL HAZARDS

3.1 SEISMIC SHAKING

The Project site is located in the highly seismic Southern California region within the influence of several fault systems that are considered to be active or potentially active. A list of known faults considered capable of producing potentially damaging seismic shaking at the site is presented in Table 2-1. It is anticipated that the Project site will periodically experience ground accelerations and shaking as the result of small to moderate magnitude earthquakes occurring along these faults and other faults within the Southern California region.

The results of our preliminary seismic hazard analyses indicated that the estimated horizontal peak ground acceleration (PGA) having a 2 percent probability of exceedance in 50 years and corresponding to the statistical return period of approximately 2,475 years, which is defined as the Maximum Considered Earthquake (MCE), is on the order of 0.97g.

3.2 FAULT-RUPTURE HAZARD

Surface rupture usually occurs along traces of known active or potentially active faults. However, many historic seismic events, including the 1994 Northridge Earthquake, have occurred on faults without surface expression (blind faults) that were not previously known to exist or to be active.

The California Geologic Survey (CGS) established criteria for faults as active, potentially active, and inactive. Active faults are those that show evidence of surface displacement within the last 11,000 years (Holocene age). Potentially active faults are those that demonstrate displacement within the past 1.6 million years (Quaternary age). Faults showing no evidence of displacement within the last 1.6 million years may be, in general, considered inactive for most structures, except for critical structures. In 1972 the Alquist-Priolo Special Studies Earthquake Hazards Act (APEHA) was passed, which required fault studies within 500 feet of active or potentially active faults. The APEHA designates “active” and “potentially active” faults utilizing the same age criteria as that used by the CGS. The site is not located within a currently-delineated State of California Alquist-Priolo Earthquake Fault Zone (Bryant and Hart, 2007 and CGS, 2019) and therefore the likelihood of fault rupture at the Project site is considered low. Location of known Alquist Priolo Earthquake Fault Zones in the general vicinity of the Project Site is shown on Figure 5, Seismic Hazard Map (Appendix A).

3.3 FLOOD HAZARD AND TSUNAMIS

Flooding can occur as a result of several factors in developed areas. These factors include: rainfall rates that exceed an area’s ability to absorb or control the runoff; impounded water retained behind a flood control structure (upstream-inundation), failure of a flood control structure (downstream-inundation), seiches, and tsunami.

According to the Federal Emergency Management Agency (FEMA) Flood Insurance Rate Map Number 06025C2125C (2008), the Project site is considered a Zone X site, which is an area that is determined to be outside the 0.2% annual chance of flooding. Therefore, the risk related to natural flooding is low.

Due to the site's inland location and the lack of any local impounded bodies of water, tsunamis, and seiches do not represent potential hazards to the site.

3.4 LANDSLIDING

Landslides and other forms of mass wasting, including mud flows, debris flows, and soil slips occur as soil moves downslope under the influence of gravity. Landslides are frequently triggered by intense rainfall or seismic shaking. Because the site is located in a relatively flat area, we do not consider landslides or other forms of natural slope instability to represent a significant hazard to the project.

3.5 LIQUEFACTION/SEISMIC SETTLEMENT

The term liquefaction describes a phenomenon in which saturated, cohesionless soils temporarily lose shear strength (liquefy) when subjected to cyclic ground motions. Cyclic loading of saturated soils leads to the build-up of pore water pressure as a result of soil particles being rearranged with a tendency toward closer packing. Under undrained conditions, shaking of loose non-cohesive soils may result in loads being transferred from the soil skeleton to the pore water with consequent reduction in the soil strength and stiffness. Structures founded on or above potentially liquefiable soils may experience bearing capacity failures due to the temporary loss of foundation support, vertical settlements (both total and differential), and/or undergo lateral spreading. The factors known to influence liquefaction potential include soil type, relative density, grain size distribution, confining pressure, depth to groundwater, and the intensity and duration of the seismic ground shaking. Liquefaction is most prevalent in loose- to medium-dense, silty, sandy, and gravelly soils below the groundwater table.

The Project site has not been mapped for liquefaction potential by CGS. Due to the limited soils and groundwater information, the liquefaction potential at the project site cannot be determined. The liquefaction potential should be further evaluated during the design phase of the Project, using site-specific information collected from future site-specific exploratory boreholes.

3.6 LATERAL SPREADING

Liquefaction-induced lateral spreading is defined as the lateral displacement of ground as a result of pore pressure build-up or liquefaction in shallow underlying soils during an earthquake. Lateral spreading can occur on sloping ground or where nearby slopes are present. The factors known to influence the magnitude of lateral spreading include earthquake magnitude, peak ground acceleration, distance between the site and the seismic event, the slope height and gradient, thickness of the liquefied layer, fines content, soil particle gradation, and residual strength of the liquefied soil.

A site-specific geotechnical investigation should be performed and mitigation measures, if necessary, should be developed to reduce the magnitude of lateral displacement due to lateral spreading.

3.7 LAND SUBSIDENCE

Subsidence is the sinking of the ground surface caused by the compression of earth materials or the loss of subsurface soil due to underground mining, tunneling, or erosion. The major causes of subsidence include fluid withdrawal from the ground, decomposing organics, underground

mining or tunneling, and placing large fills over compressible earth materials. The effective stress on underlying soils is increased resulting in consolidation and settlement. Subsidence may also be caused by tectonic processes. The Project site is not located in an area of known ground subsidence or within any delineated zones of subsidence due to groundwater pumping or oil extraction (USGS, 2021a). Accordingly, the potential for subsidence to occur at the site is considered to be low.

3.8 EXPANSIVE SOILS

Expansive soils are characterized by their ability to undergo significant volume changes (shrink or swell) due to variations in moisture content. Changes in soil moisture content can result from precipitation, landscape irrigation, utility leakage, roof drainage, perched groundwater, drought, or other factors and may result in unacceptable settlement or heave of structures. Based on available data, the onsite near-surface soil deposits primarily consist of sand, gravelly sand and clay/silty clay. Generally, sands are considered not expansive soils and clays may exhibit moderate to high expansion potential due to variation in moisture content. A site-specific geotechnical investigation should be performed to evaluate soil expansiveness and potential impact, if any, of expansive soil on the Project.

3.9 COLLAPSIBLE SOILS

Collapsible soil is generally defined as soil that will undergo a sudden decrease in volume and its internal support is lost under applied loads when water is introduced into the soil. The internal support is considered to be a temporary strength and is derived from a number of sources including capillary tension, cementing agents, e.g. iron oxide and calcium carbonate, clay-welding of grains, silt bonds, clay bonds and clay bridges. Soils found to be most susceptible to collapse include loess (fine grained wind-deposited soils), valley alluvium deposited within a semi-arid to arid climate, and residual soil deposits. At this time, it is unknown whether collapsible soils are present at the site. A site-specific geotechnical investigation should be performed to assess the presence of collapsible soils and evaluate potential impact, if any, of collapsible soils on the proposed improvements.

3.10 SOIL CORROSION

A site-specific corrosion study should be performed and mitigation measures should be recommended if the soils are found to be corrosive to concrete or steel. Generally, fine grained soils like clay are more likely to be corrosive. Typical remediation for the corrosive soil conditions consists of using concrete mix with higher cement contents (Type V Portland Cement) and appropriate steel corrosion protection. Because fine grained soils are expected to be encountered at the subject site, corrosion potential should be further evaluated during the design phase of this Project.

3.11 OTHER GEOLOGIC HAZARDS

Volcanic Eruption: The Project site is not located in an area of a recent volcanism. Therefore, the potential for volcanic activity is very low.

Radon Gas: Radon gas is a radioactive product of uranium which can reach high levels depending on the local geology and building construction. According to Environmental Protection

3.0 Assessment of Potential Geologic and Geotechnical Hazards

Agency (EPA) Map of Radon Zones, the Project site, as the entire Imperial County, is located in Zone 3 with predicted average indoor radon screening levels less than 2 picocuries per liter (pCi/L). Since the site is not located within an area of high potential for indoor radon levels (above 4 pCi/L), the potential for radon gas accumulation is considered low.

Naturally Occurring Asbestos: The site is not located in an area of known naturally occurring asbestos (CGS, 2011). Therefore, the potential for occurring asbestos is considered low.

Hazardous Materials: The site is not located in proximity to any known hazardous materials (methane gas, hydrogen sulfide gas) and the risk of hazardous materials is considered low.

4.0 PRELIMINARY SEISMIC DESIGN RECOMMENDATIONS

To reduce the effects of ground shaking produced by regional seismic events, seismic design should be performed in accordance with the applicable building codes. Preliminary seismic parameters were calculated using the California’s Office of Statewide Health Planning and Development [OSHPD] (2018) and in accordance with the 2016 California Building Code and the American Society of Civil Engineers/Structural Engineering Institute (ASCE/SEI) (2017) 7-16. Site Class D was assumed for preliminary design and must be confirmed prior to final design. Seismic design parameters for Site Class D are provided in Table 4-1.

Table 4-1. Preliminary Seismic Design Parameters

Category	Recommended Value
Risk Category	II ⁽¹⁾
Site Class	D
Latitude	32.68153°N
Longitude	115.30894°W
Mapped (5% damped) spectral response acceleration parameter at short period (0.2 sec), S_s	1.952
Mapped (5% damped) spectral response acceleration parameter at long period (1.0 sec), S_1	0.683
Short period (0.2 sec) site coefficient, F_a	1.0
Long period (1.0 sec) site coefficient, F_v	1.7
Spectral response acceleration parameter at short period (0.2 sec), S_{MS}	1.952
Spectral response acceleration parameter at long period (1.0 sec), S_{M1}	1.161
Design (5% damped) spectral response acceleration parameter at short period (0.2 sec), S_{DS}	1.302
Design (5% damped) spectral response acceleration parameter at long period (1.0 sec) S_{D1}	0.774 ⁽²⁾
Peak Ground Acceleration (PGA) (g)	0.805
Site -adjusted PGA ($PGAM$) (g)	0.966
Design Magnitude ⁽³⁾ Mw	7.1

Notes:

- (1) Risk category was assumed and should be verified by designer during final design.
- (2) See the commentary in ASCE/SEI 7-16, Section 11.4.8 for site-specific ground motion analysis and “Exception note” 2.
- (3) Design magnitude based on USGS Probabilistic Deaggregation with 2% chance of exceedance in 50 years (2,475 year return interval) (USGS, 2021c).

5.0 CONCLUSIONS AND LIMITATIONS

Our review of available geological and geotechnical literature did not reveal conditions that would preclude development of the proposed Project provided, as mentioned above, a site-specific geotechnical investigation is conducted prior to the site development. The proposed project is considered feasible for development from a geotechnical perspective.

This preliminary geological and geotechnical hazard evaluation report has been prepared for the use of HDR and Imperial County for the proposed VEGA 4 Project. The report may not be used by others without the written consent of our client and our firm. The findings, conclusions, and preliminary recommendations presented in this report were prepared in a manner consistent with the standard of care and skill ordinarily exercised by members of its profession, practicing under similar conditions in the geographic vicinity, and at the time the services were performed. No other warranty is either expressed or implied.

Our findings, conclusions and preliminary recommendations presented in this report may be used for preliminary consideration of the feasibility and cost of site development purposes only. They are not intended for the design of the project. Additionally, a site-specific geotechnical investigation should be performed during the planning process for the proposed Project, in order to develop recommendations for the specific foundation designs and earthwork construction being considered for this project.

We appreciate the opportunity to provide our services on this Project. Please do not hesitate to contact undersigned if you have questions, comments, or need additional information.

Respectfully submitted,

HDR Engineering, Inc.

Manuel Guzman, PE
Engineer - Geotechnical

Gary Goldman, PE, GE
Senior Project Manager-Geotechnical

6.0 REFERENCES

The following references were used in preparation of this report:

Bennett et al, 1996, Global Positioning System Constraints on Fault Slip Rates in Southern California and Northern Baja, Mexico, *Journal of Geophysical Research*, Volume 101, Issue B10, October 10.

Bryant, W.A. and Hart, E.W., 2007, Fault-Rupture Hazard Zones in California, *Alquist-Priolo Earthquake Fault Zoning Act with Index to Earthquake Fault Zones Maps: California Geological Survey Special Publication 42*, 42p.

California Building Code, 2016.

California Department of Water Resources, 2021, Water Data Library, <https://groundwaterwatch.usgs.gov/>, accessed January 2021.

California Geological Survey (CGS), 2010, *Geologic Map of California*.

CGS, 2011, Reported Historic Asbestos Mines, Historic Asbestos Prospects, and other Natural Occurrences of Asbestos in California, *Open File Report 2011-1188*, California Geological Survey Map Sheet 59.

CGS, 2019, California Earthquake Hazards Zone Application (EQ Zapp, updated April 4), from <<https://www.conservation.ca.gov/cgs/geohazards/eq-zapp>> website, accessed January 2021.

California's Office of Statewide Health Planning and Development (OSHPD), 2018, *Seismic Design Maps Online Tool*, Accessed January 2021, <https://seismicmaps.org/>.

Environmental Protection Agency (EPA, 1993), EPA 1993 National Radon Zone Map at: <https://www.cdph.ca.gov/Programs/CEH/DRSEM/Pages/EMB/Radon/Radon-in-California.aspx#>

Federal Emergency Management Agency (FEMA), 2008, Flood Insurance Rate Maps, FEMA Map No. 06025C2125C, available at: <https://msc.fema.gov/portal/search>

Jennings, C.W., and Bryant, W.A., 2010, *Fault Activity Map of California*, California Geologic Data Map No. 6.

Morton, P., 1997, *Geology and Mineral Resources of Imperial County, California*, County Report 7

Powell, R.E., Weldon, R.J., and Matti, J.C., 1993, *The San Andreas Fault System: Displacement, Palinspastic Reconstruction, and Geologic Evolution*, Geological Society of America, *Memoir 178*, 376 p.

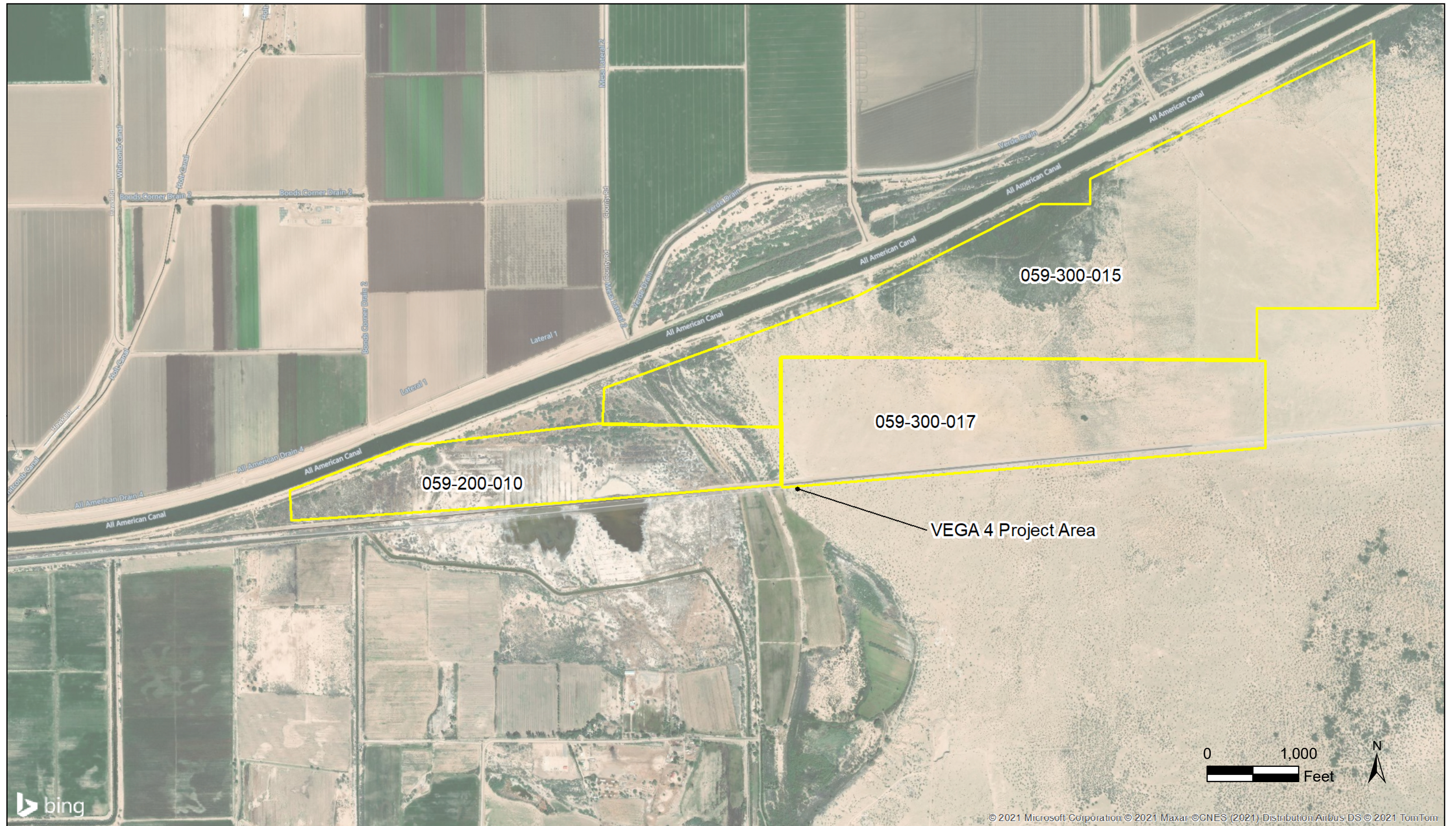
6.0 References

- Wallace, R.E. 1990, The San Andreas Fault System, California, U.S. Geological Survey Professional Paper 1515, pp. 3-12.
- Weldon, R.J., and Sieh, K.E., 1985, Holocene Rate of Slip and tentative Recurrence Interval for Large Earthquakes on the San Andreas Fault, Cajon Pass, Southern California, Geological Society of America Bulletin 96.
- United States Department of Agriculture Soil Conservation Service (2020); available at: <https://websoilsurvey.sc.egov.usda.gov/App/HomePage.htm>.
- USGS, 2006, U.S. Quaternary Fault and Fold Database, <https://usgs.maps.arcgis.com/apps/webappviewer/index.html?id=5a6038b3a1684561a9b0aadf88412fcf>.
- USGS, 2021a, Areas of Land Subsidence in California, https://ca.water.usgs.gov/land_subsidence/california-subsidence-areas.html, accessed January 2021.
- USGS, 2021b, Groundwater Watch, <https://groundwaterwatch.usgs.gov/>, accessed January 2021.
- USGS, 2021c, Search Earthquake Catalog, <https://earthquake.usgs.gov/earthquakes/search/>, Accessed January 2021.
- USGS, 2021d, Unified Hazard Tool, available at: <https://earthquake.usgs.gov/hazards/interactive/>.

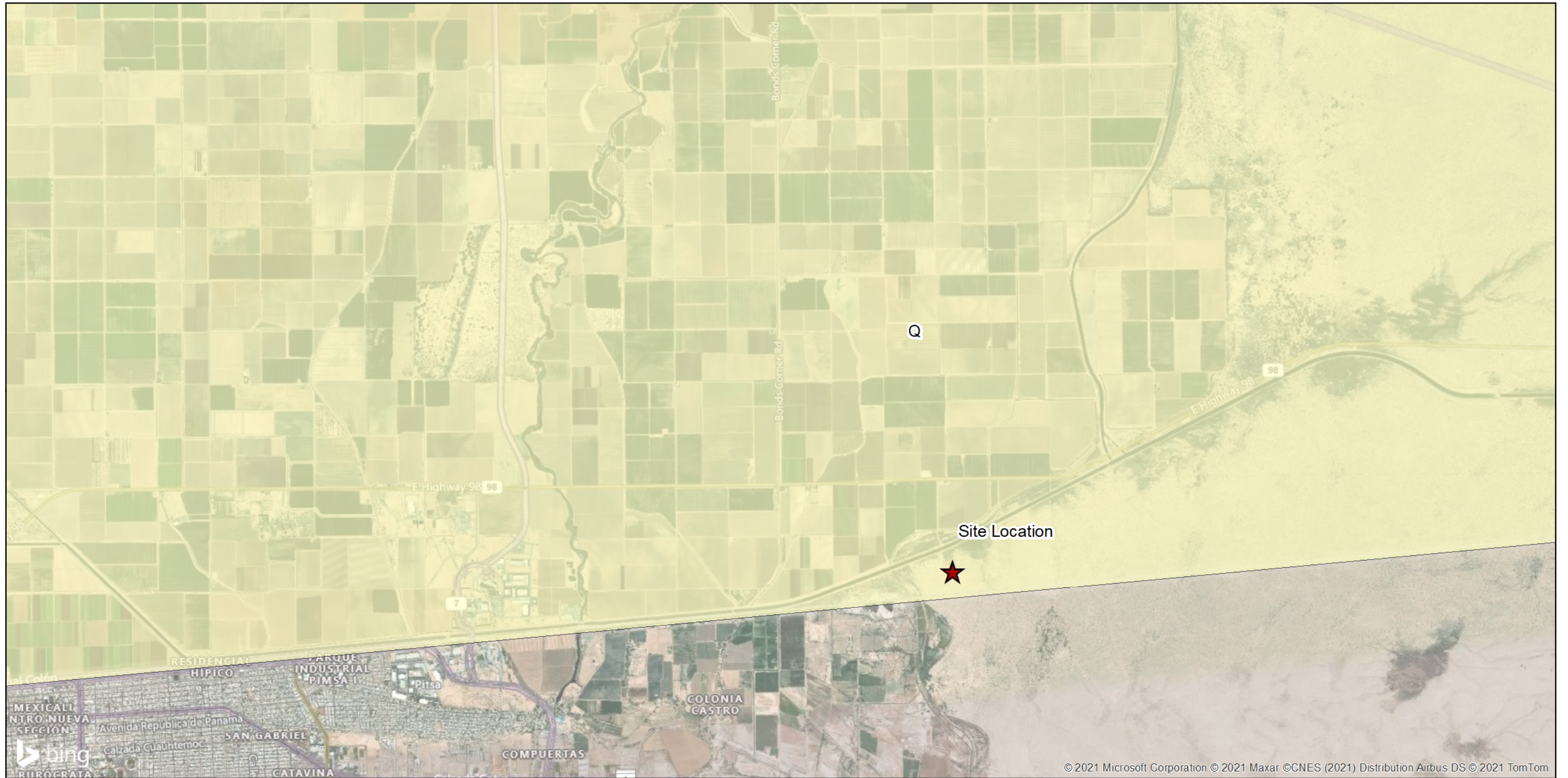
Appendix A

Figures



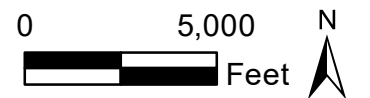


SOIL LOCATION MAP
VEGA 4
IMPERIAL COUNTY, CALIFORNIA
PC ORIGINAL PKG

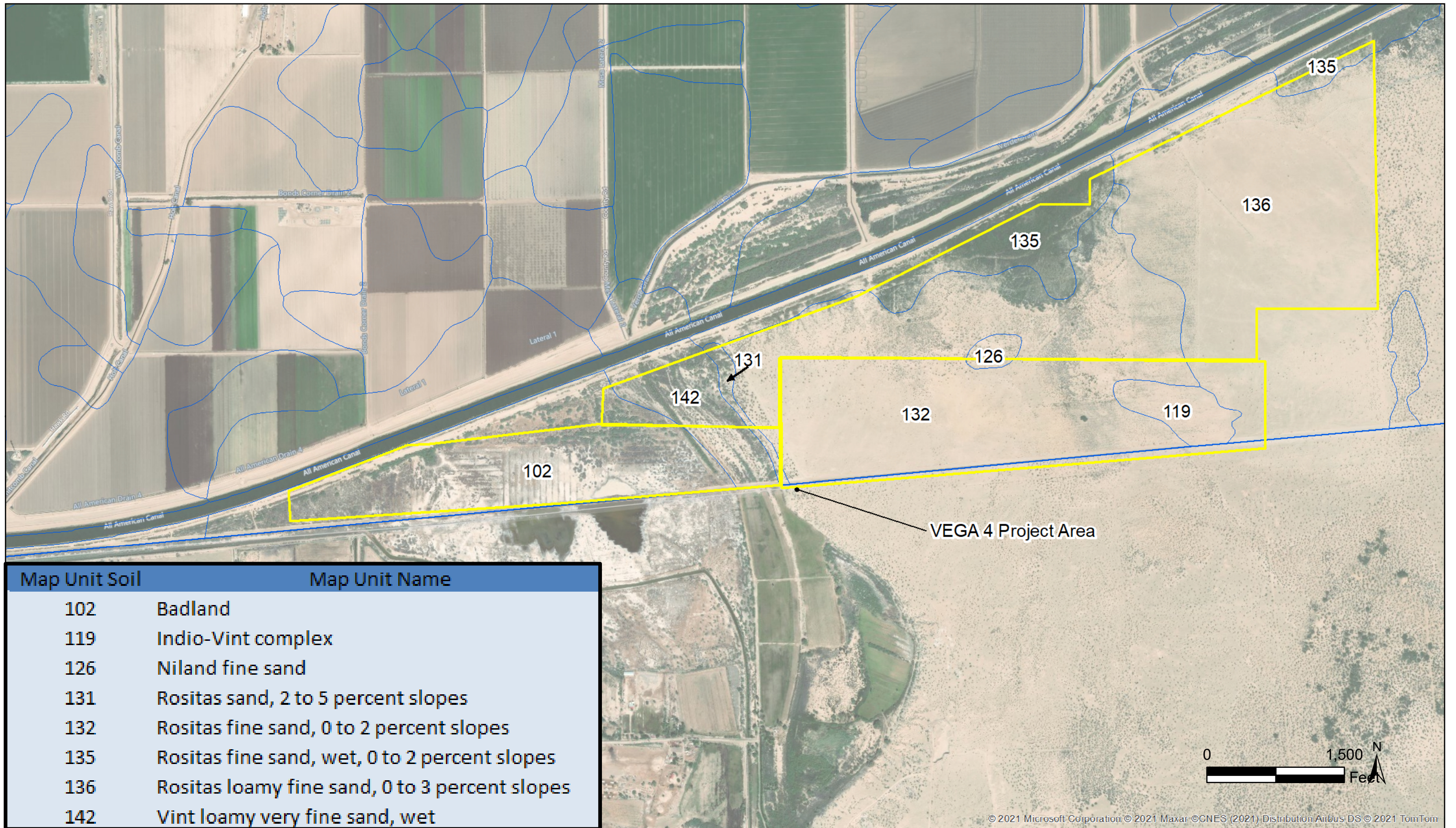


Reference: CGS, 2010, Geologic Map of California, Original compilation by Charles W. Jennings, Updated version by Carlos Gutierrez, William Bryant, George Saucedo, and Chris Wills.

Q - Alluvium, lake, playa, and terrace deposits; unconsolidated and semi-consolidated. Mostly nonmarine, but includes marine deposits near the coast.



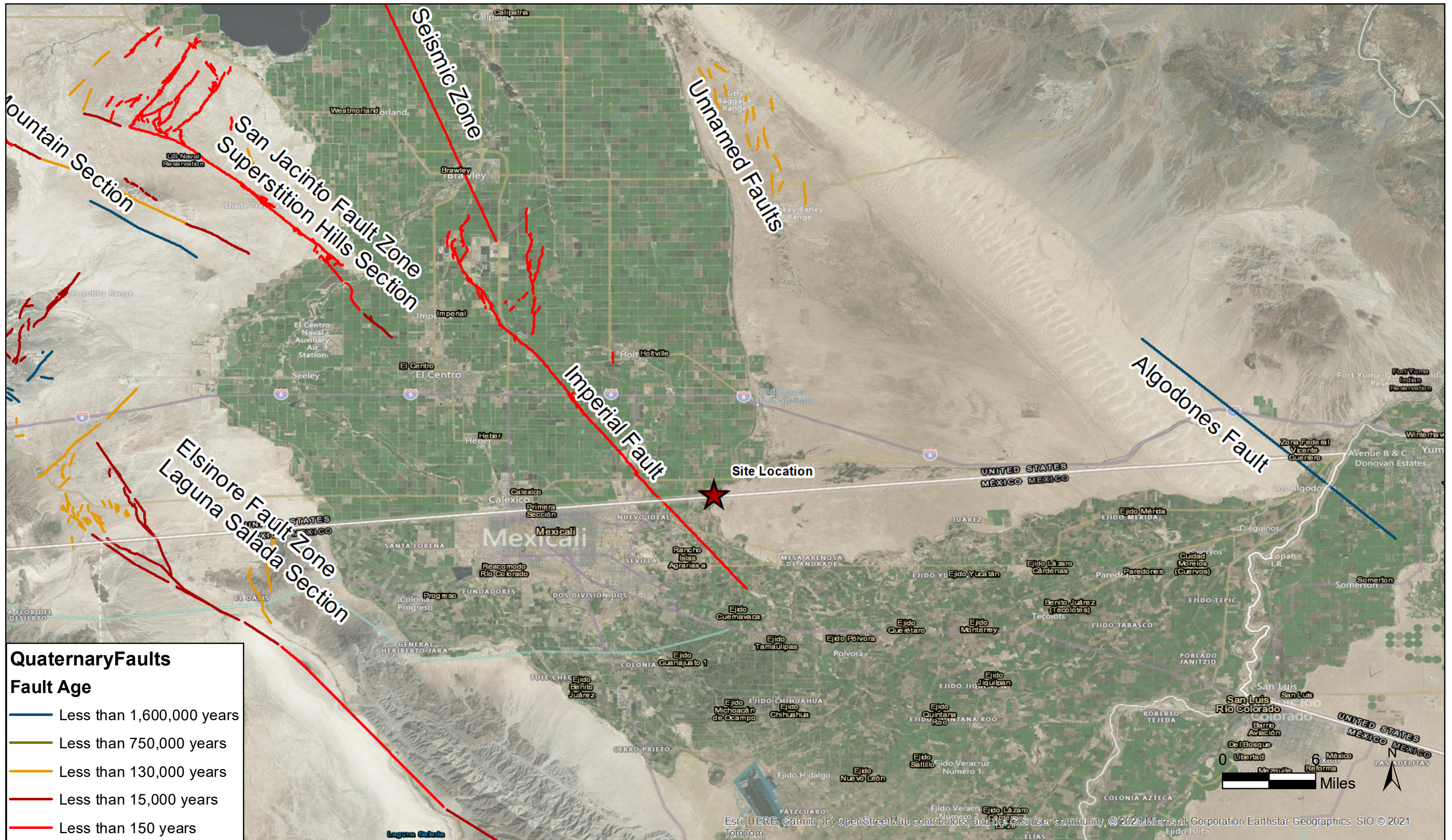
**REGIONAL GEOLOGIC MAP
VEGA 4
IMPERIAL COUNTY, CALIFORNIA
PC ORIGINAL PKG**



© 2021 Microsoft Corporation © 2021 Maxar © CNES (2021) Distribution Airbus DS © 2021 TomTom

Reference: USDA, 2020, Web Soil Survey

**SOIL SURVEY MAP
VEGA 4
IMPERIAL COUNTY, CALIFORNIA
PC ORIGINAL PKG**



Reference: USGS, 2006

**FAULT MAP
VEGA 4
IMPERIAL COUNTY, CALIFORNIA
PC ORIGINAL PKG**



Reference: CGS, 2019

**SEISMIC HAZARD MAP
VEGA 4
IMPERIAL COUNTY, CALIFORNIA
PC ORIGINAL PKG**



Phase I ESA Report

Vega 4 (Doyle Ranch) Solar Site South side of the AAC at Bonesteele Road Holtville, California

Prepared for:

Vega SES 4, LLC
750 Main Street
El Centro, CA 92243



Prepared by:



GS Lyon Consultants, Inc.
780 N. 4th Street
El Centro, CA 92243
(760) 337-1100

December 2020

PC ORIGINAL PKG



Engineering And
Information Technology

December 17, 2020

Mr. Ziad Alaynon
Vega SES 4, LLC
750 Main Street
El Centro, CA 92243

**Phase I Environmental Site Assessment Report
Vega 4 (Doyle Ranch) Solar Site
Holtville, California
*GSL Report No. GS2015***

Dear Mr. Alaynon:

We have performed a Phase I Environmental Site Assessment in general conformance with the scope and limitations of ASTM E1527-13 of the approximately 530-acre property located on the south side of the All American Canal at Bonesteele Road approximately 10 miles south of Holtville, California. Any exceptions to, or deletions from, this practice are described in Section 1.4 of this report. **This assessment has revealed the following “de minimis” conditions in connection with the property:**

- Pesticide residues (low concentrations) typical to agricultural crop applications are present in the near surface soils.
- Pole-mounted sealed electrical transformers owned and maintained by the Imperial Irrigation District (IID) exist on this subject property. All IID transformers containing PCB's have been replaced. ***If the transformers begin to leak, the IID should be notified and the transformers replaced.***

This assessment has not revealed any recognized environmental conditions (REC's) in connection with the property.

We declare that, to the best of our professional knowledge and belief, we meet the definition of *Environmental Professional* as defined in §312.10 of 40 CFR §312 and we have the specific qualifications based on education, training and experience to assess a property of the nature, history, and setting of the subject property. We have developed and performed all the appropriate inquiries in conformance with the standards and practices set forth in 40 CFR Part 312.

PC ORIGINAL PKG

Attached is our report which describes the procedures used and results of the assessment. If you have any questions or require additional information, please do not hesitate to contact the undersigned at (760) 337-1100. We appreciate the opportunity to provide our professional review for this subject property.

Respectfully Submitted,
GS Lyon Consultants, Inc.



Jeffrey O. Lyon, PE
Principal Engineer



Steven K. Williams, PG, CEG
Consulting Geologist



TABLE OF CONTENTS

1.0 INTRODUCTION 1

 1.1 Purpose 1

 1.2 Scope of Services 1

 1.3 Limitations 2

 1.4 Deviations or Data Gaps 2

 1.4.1 Data Failures 3

 1.4.2 Data Gaps..... 3

 1.5 Significant Assumptions 3

 1.6 User Reliance 4

2.0 SITE DESCRIPTION 5

 2.1 Site Location and Legal Description 5

 2.2 Current Property Use and Description 5

 2.3 Adjoining Property Use..... 5

 2.4 Physical Site Characteristics 5

3.0 USER PROVIDED INFORMATION 7

 3.1 Title Records 7

 3.2 Environmental Liens or Activity and Use Limitations 7

 3.3 Specialized Knowledge 8

 3.4 Commonly Known or Reasonable Ascertainable Information 8

 3.5 Valuation Reduction for Environmental Issues 8

 3.6 Owner, Property Manager, and Occupant Information..... 8

 3.7 Previous Reports and Other Provided Documentation 8

4.0 RECORDS REVIEW..... 9

 4.1 Regulatory Database Review 9

 4.1.1 Standard Environmental Record Sources 9

 4.1.2 Additional Environmental Record Sources 13

 4.2 Historical Use Records..... 14

 4.2.1 Title Records..... 14

 4.2.2 Sanborn Fire Insurance Maps 15

 4.2.3 Aerial Photographs..... 15

 4.2.4 Street Directories 16

 4.2.5 Historic Topographic Maps 16

 4.2.6 Historical Telephone Directories 16

 4.3 Historical Use Summary 16

 4.3.1 Summary of the Historical Use of Property..... 16

 4.3.2 Summary of the Historical Use of Adjacent Properties..... 16

5.0 SITE RECONNAISSANCE 17

 5.1 Methodology and Limiting Conditions 17

 5.2 General Site Setting..... 17

 5.3 Adjacent Properties 18

 5.4 Exterior and Interior Observations 18

 5.4.1 Hazardous Substances and Petroleum Products 18

 5.4.2 Storage Tanks..... 18

 5.4.3 Odors..... 18

5.4.4 Pools of Liquid..... 18

5.4.5 Drums and Containers..... 19

5.4.6 Unidentified Substance Containers..... 19

5.4.7 Suspect Polychlorinated Biphenyl (PCB) Containing Equipment..... 19

5.5 Interior Observations..... 19

5.6 Exterior Observations..... 19

5.6.1 Pits, Ponds, and Lagoons 19

5.6.2 Stained Soils or Pavement 19

5.6.3 Stressed Vegetation..... 19

5.6.4 Solid Waste 19

5.6.5 Wastewater..... 19

5.6.6 Wells 20

5.6.7 Septic Systems 20

5.7 Non-Scope Issues 20

5.7.1 Asbestos-Containing Building Materials..... 20

5.7.2 Lead-Based Paint 20

5.7.3 Radon 20

5.7.4 Agricultural Use..... 20

6.0 INTERVIEWS 21

6.1 Interview with Owner..... 21

6.2 Interview with the Site Manager 21

6.3 Interview with Occupants..... 21

6.4 Interview with Local Government Officials 21

7.0 EVALUATION..... 22

7.1 Summary of Findings..... 22

7.2 Conclusions 22

7.2.1 Recognized Environmental Conditions 22

7.2.2 Historical Recognized Environmental Conditions..... 23

7.2.3 Environmental Concerns and De Minimis Conditions 23

7.3 Recommendations 23

8.0 REFERENCES 24

APPENDICES

- Appendix A: Site Photographs
- Appendix B: Vicinity, Site, and Soils Maps
- Appendix C: Historical Aerial Photographs
- Appendix D: Historical Topographic Maps
- Appendix E: EDR Environmental Records Search Report
- Appendix F: Other Environmental Records Search Results
- Appendix G: Preliminary Title Report
- Appendix H: User Questionnaire and EDR Environmental Lien and AUL Search
- Appendix I: Resumes of Environmental Professionals

1.0 INTRODUCTION

1.1 Purpose

GS Lyon Consultants, Inc. was retained by Vega SES 4, LLC to conduct a Phase I Environmental Site Assessment (ESA) for the Property (herein referred to as the subject property or subject site in this Phase I ESA Report) as a prerequisite to property transaction (purchase, sale, refinance, etc.). The approximately 530-acre subject property is located on the south side of the All American Canal at Bonesteele Road approximately 10 miles south of Holtville, California. See Plate 1 in Appendix B for a Vicinity Map of the subject property.

The purpose of this Phase I Environmental Site Assessment (ESA) is to identify, to the extent feasible, recognized environmental conditions (RECs) associated with past and present activities on the subject property or in the immediate subject property vicinity in general conformance to ASTM Standard E1527-13 “*Standard Practice for Environmental Site Assessments: Phase I Environmental Site Assessment Process*” that may affect future uses of the subject property.

This report is intended to satisfy the Phase I ESA portion of “*all appropriate inquiry*” into the previous ownership and uses of the subject property as defined under the Comprehensive Environmental Response, Compensation, and Liability Act (CERCLA) at Title 42 of the United States Code (U.S.C.) §9601(35)(B) and in accordance with 40 Code of Federal Regulations (CFR) Part 312, Standards and Practices for All Appropriate Inquiries; Final Rule (AAI Rule).

1.2 Scope of Services

The scope of work for this ESA is in general accordance with the requirements of ASTM Standard E1527-13. This assessment included:

- Reconnaissance of the subject property and adjacent properties
- Review user-provided information
- Interviews with persons with significant knowledge of the subject property
- Review of a regulatory database report provided by a third-party vendor
- Review readily-available historical sources (including but not limited to: aerial photographs, fire insurance maps, property tax files, recorded land title records, and topographical maps)
- Prepare report of findings

1.3 Limitations

No Phase I ESA can completely eliminate uncertainty regarding the potential for RECs in connection with a property. Conformance of this assessment with ASTM Standard E1527-13 is intended to reduce, but not eliminate uncertainty regarding the potential for RECs in connection with the Subject Property. While GS Lyon has made reasonable effort to discover and interpret available historical and current information on the property within the time available, the possibility of undiscovered contamination remains. Our assessment of the subject property and surrounding areas was conducted in accordance with ASTM guidelines and the *generally accepted environmental engineering standard of practice* which existed in Imperial County, California at the time that the report was prepared. No warranty, express or implied, is made.

GS Lyon Consultants, Inc. derived the data in this report primarily from visual inspections, examination of public records and information in the public domain, informal interviews with individuals, and readily available information about the subject property. The passage of time, manifestation of latent conditions or occurrence of future events may require further exploration of the subject property, analysis of the data, and reevaluation of the findings, observations, and conclusions expressed in this report.

The findings, observations, and conclusions expressed by GS Lyon Consultants in this report are not, and should not be considered, an opinion concerning the compliance of any past or present owner or operator of the subject property with any federal, state or local law or regulation.

This report should not be relied upon after **180 days** from the date of issuance, unless additional services are performed as defined in ASTM E1527-13 - Section 4.7.

1.4 Deviations or Data Gaps

ASTM Standard E1527-13 requires any significant data gaps, deviations, and deletions from the ASTM Standard to be identified and addressed in the Phase I ESA. A significant data gap would be one that affected the ability to identify a REC on the subject property or adjacent properties.

Through the course of this assessment, *data failures* or *data gaps* may have been encountered. These failures or gaps, if any, are discussed below. The following provides the opinion of the Environmental Professional as to the significance of the data gaps in terms of defining *recognized environmental conditions* at the subject property. Data failures may or may not be significant data gaps, and the discussion also provides information pertaining to whether the data failures resulted in significant data gaps.

1.4.1 Data Failures

Data failure is a failure to achieve the historical (property use) research objectives specified in the ASTM Standard Practice even after reviewing the eight standard historical sources that are reasonably ascertainable and likely to be useful. Data failure is one type of data gap. No *data failures* were encountered during this investigation.

1.4.2 Data Gaps

A *data gap* is a lack of or inability to obtain information required by the ASTM Standard Practice, despite good faith efforts by the Environmental Professional to gather such information. This could include any component of the Practice, e.g., standard environmental records, interviews, or a complete reconnaissance. A data gap by itself is not inherently significant, but if other information and/or the EP's experience raises reasonable concerns about the gap, it may be judged to be significant.

Due to the location of the subject property, Sanborn Fire Insurance maps were not available for the subject property. Because there is no historical data or physical indications that the property has ever been developed or occupied by a business that would have produced hazardous materials, the lack of Sanborn Fire Insurance maps is not considered a significant data gap.

Aerial photographs and other historical records were not available at 5 year intervals as required under the ASTM E1527-13 standard. This resulted in a data gap for years that records were not available regarding the area of the subject property. However, based upon other historical information reviewed, the subject property has been vacant desert land up to about 1980 when a portion of the subject property was converted into agricultural use. Therefore, this data gap is not considered to be significant.

Interviews with past owners, operators and occupants were not reasonably ascertainable and thus constitute a data gap. Based on information obtained from other historical sources (as discussed in Section 3.0), this data gap is not expected to alter the findings of this assessment.

1.5 Significant Assumptions

In preparing this report, GS Lyon Consultants, Inc. has relied upon and presumed accurate certain information (or the absence thereof) about the subject property and adjacent properties by governmental officials and agencies, the Client, and others identified herein. Except as otherwise stated in the report, GS Lyon Consultants has not attempted to verify the accuracy or completeness of any such information.

1.6 User Reliance

This report has been prepared on behalf of and for the exclusive use of Vega SES 4, LLC for the particular subject property identified in this report, and is subject to and issued in connection with the referenced Agreement and the provisions thereof. This report should not be relied upon by any party other than the client, its legal counsel, and financial institution without the express permission of GS Lyon Consultants, Inc. Any reliance on this report by other parties shall be at such party's sole risk. Any future consultation or provision of services to third parties related to the subject property requires written authorization from Vega SES 4, LLC or their representatives. Any such services may be provided at GS Lyon Consultants sole discretion and under terms and conditions acceptable to GS Lyon Consultants, including potential additional compensation.

2.0 SITE DESCRIPTION

2.1 Site Location and Legal Description

The approximately 530-acre subject property (APNs 059-299-010, 059-300-017, and 059-300-015) is located on the south side of the All American Canal at Bonesteele Road approximately 10 miles south of Holtville, California. The subject property location is depicted on Plate 1, Site Map.

2.2 Current Property Use and Description

The subject property currently consists of approximately 530 acres comprised of three parcels (APNs 059-299-010, 059-300-017, and 059-300-015). The subject property is roughly triangular in plan view with the All American Canal forming the northern boundary, the International Border with the Republic of Mexico forming the southern boundary and vacant desert land forming the eastern boundary. The majority of the subject site has been cleared of desert vegetation for agricultural use. The western wedge and a small area in the north-central portion of the site are heavily vegetated where shallow groundwater has accumulated due to seepage from the earthen All American Canal.

A farm yard is located in the north-central portion of the subject site. A small masonry building housing water pumps, an above ground fuel storage tank (AST) and a storage building, all located within a chain-link fenced area comprise the farm yard. A bank of pole mounted transformers is located on the embankment of the All American Canal adjacent to the farm yard. A small equipment storage area with a disc, a trap wagon, and other miscellaneous farm implements is located northeast of the farm yard area. There are two central-pivot sprinklers that are located in the central portion of the site.

2.3 Adjoining Property Use

The subject property is located within a mixed agricultural and undeveloped desert area south of Holtville, California. Adjacent properties consist of the International Border with the Republic of Mexico along the southern boundary of the subject site and the All American Canal along the northern margin of the subject site.

2.4 Physical Site Characteristics

Topography: Topographic maps (USGS 7.5 minute Bonds Corner, CA Quadrangle) indicate that the subject property elevation is approximately 35 to 60 feet above mean sea level (MSL) or Elevation 1035 to 1060 (local datum). The Imperial Irrigation District, which supplies power and raw (irrigation) water to the area, established local datum by equating mean sea level to El. 1000.00 feet. The shoreline for the ancient Lake Cahuilla crosses the site at El. +43 ft. MSL.

Geologic Setting: The subject property is located in the Colorado Desert Physiographic province of southern California. The dominant feature of the Colorado Desert province is the Salton Trough, a geologic structural depression resulting from large-scale regional faulting. The trough is bounded on the northeast by the San Andreas Fault and the southwest by faults of the San Jacinto Fault Zone. The Salton Trough represents northward extension of the Gulf of California, which has experienced continual in-filling with both marine and non-marine sediments since the Miocene Epoch (25 million years before present). The tectonic activity that formed the trough continues at a high rate as evidenced by deformed young sedimentary deposits and high levels of historic seismicity.

The subject property is directly underlain by Holocene (0-11,000 years before present) Cahuilla Lake sediments, which consist of interbedded lenticular and tabular sand, silt, and clay. The predominant surface soil is silty clay. The Holocene lake deposits are considered to be less than 100 feet thick and are characterized by surficial clay and silt deposits with varying amounts of fine sand. The topography of the Imperial Valley is relatively flat, with few significant land features. The valley floor slopes gently to the north (less than 0.5 percent) from an elevation of sea level at Calexico to approximately 225 feet below sea level at the Salton Sea.

Soil Conditions: The U. S. Soil Conservation Service compiled a map of surface soil conditions and published a soil survey report including maps in 1980. The soil survey maps indicate that surficial deposits at the subject property and surrounding area consist predominantly of silt and silty sand loams of the Indio-Vint, Niland, Rositas and Vint soil groups (see Appendix B). These loams are formed in sediment and alluvium of mixed origin (Colorado River overflows and fresh-water lake-bed sediments). Based on Unified Soil Classification System presented in the Soils Survey Report, the permeability of these soils is expected to be low to moderate.

Groundwater Conditions: The groundwater in the vicinity of the subject property is brackish and is encountered at a depth of near surface to greater than 50 feet below the ground surface. Depth to groundwater may fluctuate due to localized geologic conditions, water level and seepage from the All American Canal, precipitation, irrigation, drainage and construction practices in the region. Based on the regional topography, groundwater flow is assumed to be generally towards the northwest within the subject property area. Flow directions may also vary locally across and in the vicinity of the subject property.

3.0 USER PROVIDED INFORMATION

In order to qualify for one of the *Landowner Liability Protections (LLPs)* offered by the Small Business Liability Relief and Brownfields Revitalization Act of 2001 (the *Brownfields Amendments*), the *User* must provide the following information (if available) to the *environmental professional*. Failure to provide this information could result in a determination that *all appropriate inquiry* is not complete. The user was asked to provide information or knowledge of the following:

- Environmental cleanup liens that are filed or recorded against the subject property.
- Activity and land use limitations that are in place on the subject property or that have been filed or recorded in a registry.
- Specialized knowledge or experience of the person seeking to qualify for the LLPs.
- Relationship of the purchase price to the fair market value of the *property* if it were not contaminated.
- Commonly known or *reasonably ascertainable* information about the *property*.
- The degree of obviousness of the presence or likely presence of contamination at the *property*, and the ability to detect the contamination by appropriate investigation.
- The reason for preparation of this Phase I ESA.

A user questionnaire was provided to the user to aid in gathering information that may be pertinent to the evaluation of the subject property for environmental conditions. The completed user questionnaire is provided in Appendix G.

3.1 Title Records

GS Lyon reviewed preliminary title reports as part of this assessment and did not find past ownership or easements that would indicate environmentally hazardous uses on the parcels.

3.2 Environmental Liens or Activity and Use Limitations

An environmental lien is a charge, security, or encumbrance upon the title to a property to secure the payment of a cost, damage, debt, obligation, or duty arising out of response actions, cleanup, or other remediation of hazardous substances or petroleum products upon the property. According to the User Questionnaire, Ms. Jamie Nagel of Apex Energy Solutions, LLP is not aware of any Environmental Liens or Activity and Use Limitations associated with the subject property that have been filed or recorded under federal, tribal, state or local law (Appendix G). No environmental liens associated with the subject property were noted in the preliminary title report.

3.3 Specialized Knowledge

According to the User Questionnaire, Ms. Nagel is not aware of any specialized knowledge or experience associated with the subject property or nearby properties. GS Lyon does not have any personal knowledge of the subject property.

3.4 Commonly Known or Reasonable Ascertainable Information

No information was provided by the Client regarding any commonly known or reasonably ascertainable information within the local community that is material to RECs in connection with the subject property.

3.5 Valuation Reduction for Environmental Issues

The client indicated that the purchase price of this property reasonably reflects the fair market value of the property with no discounts for environmental issues.

3.6 Owner, Property Manager, and Occupant Information

The current owner of the subject property is the Doyle Family 2010 Trust. The subject property is currently undeveloped desert land. No property manager or occupant information is available.

3.7 Previous Reports and Other Provided Documentation

No previous reports or other pertinent documentation was provided to GS Lyon for review during the course of this assessment.

4.0 RECORDS REVIEW

A review of historic aerial photographs (Appendix C), historic topographic maps (Appendix D), governmental regulatory databases (Appendix E), other regulatory and agency databases (Appendix F), and historic telephone and city directories was performed to evaluate potentially adverse environmental conditions resulting from previous ownership and uses of the subject property. The details of the review are presented in Sections 4.1 through 4.5 of this report.

4.1 Regulatory Database Review

4.1.1 Standard Environmental Record Sources

GS Lyon Consultants contracted Environmental Data Resources, Inc. (EDR) of Shelton, Connecticut which queries and maintains comprehensive environmental databases and historical information, including proprietary databases, aerial photography, topographic maps, Sanborn Maps, and city directories to generate a compilation of Federal, State and Tribal regulatory lists containing information regarding hazardous materials occurrences on or within the prescribed radii of ASTM E1527-13. The search of each database was conducted using the approximate minimum search distances from the subject property defined by the ASTM E1527-13 Standard. The purpose of the records review is to obtain and review *reasonably ascertainable* records that will help identify *recognized environmental conditions* or *historical recognized environmental conditions* in connection with the subject property.

EDR's Phase I ESA search package was ordered and performed on August 27, 2020. The search package included: Radius Map with Geocheck, aerial photographs, and historic topographic maps. The results of EDR's search were used to evaluate if the subject property and/or properties within prescribed search distances are listed as having a past or present record of actual or potential environmental impact. Inclusion of a property in a government database list does not necessarily indicate that the property has an environmental problem.

The following is a brief synopsis of sites identified in the EDR Radius Map with Geocheck report. The government record search report is included in its entirety in Appendix E.

Federal NPL List

The Environmental Protection Agency's (EPA) National Priorities List (NPL) of uncontrolled or abandoned hazardous waste sites was reviewed for risk sites within a 1 mile radius of the subject property. The NPL identifies sites for priority cleanup and long-term care of properties under the Superfund Program that are contaminated with hazardous substances.

The database search did not identify any NPL sites within 1 mile of the subject property.

Federal CERCLIS List

The EPA's Comprehensive Environmental Response, Compensation, and Liability Information System (CERCLIS) listings were reviewed to determine if risks sites within ½ mile are listed for investigation. The CERCLIS database identifies hazardous waste sites that are on or proposed to be included in the NPL and sites that require investigation and possible remedial action to mitigate potential negative impacts on human health or the environment.

The CERCLIS database search did not identify any risk sites within 0.5 mile of the subject property.

Federal CERCLIS – No Further Remedial Action Planned

The EPA's CERCLIS – No Further Remedial Action Planned (NFRAP) database was reviewed to determine if risks sites within ½ mile are listed. CERCLIS NFRAP site are risk sites that have been removed from and archived from the inventory of CERCLIS sites. Archived status indicates that, to the best of EPA's knowledge, assessment at the subject property has been completed and the EPA has determined that no further steps will be taken to list this subject property on the NPL, unless information indicates this decision was not appropriate or other considerations require a recommendation for listing at a later time.

This designation is for sites where no contamination was found, contamination was quickly removed without the need for the subject property to be placed on the NPL, or the contamination was not serious enough to require Federal Superfund action or NPL consideration.

The CERCLIS – NFRAP database search did not identify any risk sites within ½mile of the subject property.

Federal RCRA List

The Federal Resource Conservation Recovery Act (RCRA) Notifiers List was reviewed to determine if RCRA treatment, storage or disposal sites (TSD) are located within 1 mile of the subject property. The RCRA Correction Action Sites List (CORRACTS) is maintained for risk sites which are undergoing "a corrective action". A corrective action order is issued when there has been a release of hazardous waste constituents into the environment from a RCRA facility.

The RCRA and RCRA CORRACTS database searches did not identify any RCRA TSD or RCRA CORRACTS risk sites within ½ mile of the subject property.

The RCRA regulated hazardous waste generator notifiers list was reviewed to determine if RCRA generator facilities are located on or adjoining the subject property. No RCRA generator facilities within ¼ mile of the subject property were identified in the database.

Federal ERNS List

The Federal Emergency Response Notification System (ERNS) List was reviewed to determine if reported release of oil and/or hazardous substances occurred on the subject property.

The ERNS database searches did not identify any reported releases for the subject property.

State and Tribal NPL List

The Environmental Protection Agency's (EPA) National Priorities List (NPL) of uncontrolled or abandoned hazardous waste sites was reviewed for risk sites within a 1 mile radius of the subject property. The NPL identifies sites for priority cleanup and long-term care of properties under the Superfund Program that are contaminated with hazardous substances.

The database search did not identify any NPL sites within 1 mile of the subject property.

State and Tribal equivalent CERCLIS

The Department of Toxic Substances Control's (DTSC's) Site Mitigation and Brownfields Reuse Program's (SMBRP's) EnviroStor database identifies sites that have known contamination or sites for which there may be reasons to investigate further. The database includes the following site types: Federal Superfund sites (National Priorities List (NPL)); State Response, including Military Facilities and State Superfund; Voluntary Cleanup; and School sites. EnviroStor provides similar information to the information that was available in CalSites, and provides additional site information, including, but not limited to, identification of formerly-contaminated properties that have been released for reuse, properties where environmental deed restrictions have been recorded to prevent inappropriate land uses, and risk characterization information that is used to assess potential impacts to public health and the environment at contaminated sites.

The EnviroStor database search did not identify any reported releases for the subject property.

State and Tribal Leaking Underground Storage Tank Sites

The California State Water Resources Control Board (SWRCB) maintains a list of information concerning reported leaking underground storage tanks (LUST). The LUST inventory list was reviewed to determine if any LUSTs are located within ½ mile the subject property.

The SWRCB LUST database did not identify any risk sites within ½ mile of the subject property.

State and Tribal Underground and Aboveground Storage Tank Sites

The California State Water Resource Control Board (SWRCB) underground storage tank (UST) and above ground storage tank (AST) inventory list was reviewed to determine if any UAST's are located on or adjacent to the subject property.

The SWRCB UST and AST databases did not identify any risk sites within ¼ mile of the subject property.

Solid Waste Disposal/Landfill Facilities

The Solid Waste Disposal/Landfill Sites records typically contain an inventory of solid waste disposal facilities or landfills in a particular state. The data comes from the Integrated Waste Management Board's Solid Waste Information System (SWIS) database.

A review of the SWF/LF list database did not identify any risk sites within ½ mile of the subject property.

Unmapped (Orphan) Sites

Not all sites or facilities identified in the database records can be accurately located in relation to the Subject Property due to incomplete information being supplied to the regulatory agencies and are referred to as "orphan sites" by EDR.

The "Orphan Summary" section of the EDR Radius Map Report identified several orphan sites. Based on a drive-by reconnaissance of the Subject Property vicinity and review of location and status information provided in the database report, none of the identified orphan sites are located within the search radii for databases specified by the Standard.

No unmapped (orphan) listings were reported.

4.1.2 Additional Environmental Record Sources

California Department of Toxic Substances Control (DTSC) Records – Envirostor Database: EnviroStor is an online search and Geographic Information System tool for identifying sites that have known contamination or sites for which there may be reasons to investigate further. Public Access to EnviroStor is accessible via the DTSC Web Page located at: <http://www.envirostor.dtsc.ca.gov/public/>. The EnviroStor database includes the following site types: Federal Superfund sites (National Priority List); State Response, including Military Facilities and State Superfund; Voluntary Cleanup; and School sites. The information includes site name, site type, status, address, any restricted use (recorded deed restrictions), past use(s) that caused contamination, potential contaminants of concern, potential environmental media affected, site history, planned and completed activities. The EnviroStor database also contains current and historical information relating to Permitted and Corrective Action facilities. The EnviroStor database includes current and historical information on the following permit-related documents: facility permits; permit renewal applications; permit modifications to an existing permit; closure of hazardous waste management units (HWMUs) or entire facilities; facility corrective action (investigation and/or cleanup); and/or post-closure permits or other required post-closure activities.

The EnviroStor database was queried on September 9, 2020. A map showing the results of the query is provided in Appendix F. No reported cases were found on the subject property. No risk sites were located within 1 mile of the subject property.

California State Water Resources Control Board Records – GeoTracker Database: GeoTracker is a geographic information system (GIS) maintained by the California State Water Resources Control Board (SWRCB) that provides online access to environmental data at <http://www.geotracker.swrcb.ca.gov/>. GeoTracker tracks regulatory data about underground fuel tanks, fuel pipelines, and public drinking water supplies. Site information from the Spills, Leaks, Investigations, and Cleanups (SLIC) Program is also included in GeoTracker.

The GeoTracker database was queried for environmental data pertaining to the Subject property on September 9, 2020. A map showing the results of the query is provided in Appendix F. No reported cases were found on the subject property. No risk sites were located within 1 mile of the subject property.

CUPA Records Search: The Unified Program consolidates, coordinates, and makes consistent the administrative requirements, permits, inspections, and enforcement activities of six environmental and emergency response programs. Cal/EPA and other state agencies set the standards for their programs while local governments implement the standards—these local implementing agencies are called Certified Unified Program Agencies (CUPA).

The DTSC Imperial CUPA office was contacted (Veronica Lopez) by email on September 9, 2020. CUPA records were searched for environmental issues related to the subject property. The DTSC indicated that records are filed per address, and with no known address associated with the subject property, no records were found associated with the subject property.

4.2 Historical Use Records

ASTM E1527-13 requires the environmental professional to identify all obvious uses of the property from the present back to the property's first developed use or 1940, whichever is earliest. This information is collected to identify the likelihood that past uses have led to RECs in connection with the property. This task is accomplished by reviewing standard historical sources to the extent that they are necessary, reasonably ascertainable, and likely to be useful. These standard records include aerial photographs, fire insurance maps, property tax files, land title records, topographic maps, city directories, telephone directories, building department records, and zoning/land use records.

The general type of historical use (i.e., commercial, retail, residential, industrial, undeveloped, office) should be identified at 5-year intervals, unless the specific use of the property appears to be unchanged over a period longer than 5 years. The historical research is complete when the use is defined or when data failure occurs. Data failure occurs when all of the standard historical sources have been reviewed, yet the property use cannot be identified back to its first developed use or to 1940. Data failure is not uncommon in trying to identify the use of the property at 5-year intervals back to first use or 1940, whichever is earlier.

GS Lyon reviewed the following historical records to identify obvious uses of the subject property from the present back to the property's first developed use, or to 1940, whichever is earlier. The results of this research and data failure, if encountered, are presented in the following sections.

4.2.1 Title Records

GS Lyon was provided with preliminary title records for review as part of this assessment.

4.2.2 Sanborn Fire Insurance Maps

Sanborn Fire Insurance Maps are large scale maps depicting the commercial, industrial, and residential sections of various cities across the United States. Since the primary use of the fire insurance maps was to assess the buildings that were being insured, the existence and location of fuel storage tanks, flammable or other potentially toxic substances, and the nature of businesses are often shown on these maps. Due to the rural undeveloped nature of the subject property and vicinity for the years the Sanborn Fire Insurance Maps were available for this subject property, no maps are available for the subject property.

4.2.3 Aerial Photographs

Aerial photographs obtained from Environmental Data Resources (EDR) dating back to 1937 and Google Earth aerial photographs dating back to 1996 were reviewed for historical development of the subject property. Reproductions of the historical aerial photographs reviewed are included in Appendix C.

The 1937 aerial shows the western portion of the subject site as appearing to be a fallow agricultural field. The eastern portion is vacant desert land. The recently constructed All American Canal (Bureau of Reclamation – Boulder Canyon Project – 1933) is located north of the subject site. Two canals cross the All American Canal and the western portion of the subject site from Mexico.

The 1953 aerial photograph shows the western portion of the subject site as being a fallow agricultural field. The canals that crossed the All American Canal have been removed leaving a heavily brushed area in the western portion of the subject site. The eastern portion is still vacant desert land.

The 1976 aerial photograph is similar to the 1953 aerial photograph.

The 1985 aerial photograph shows a circular agricultural area occupying the eastern portion of the subject site. This is the location of the center-pivot sprinkler. The eastern portion of the subject site is vacant with overgrown brush.

The 1996, 2002, 2006 and 2010 aerial photographs are similar to the 1985 aerial photograph. Several small structures are noted in the area of the farm yard in the north-central portion of the subject site.

The 2014 aerial photograph shows that additional desert land to the west of the circular field has been cleared for agricultural use. Standing water (All American Canal seepage) and surficial salts are noted in the western portion of the subject site.

The 2018 aerial photograph shows the subject site as being similar to the present time. The agricultural fields have been fallowed.

4.2.4 Street Directories

GS Lyon Consultants conducted a search of historic city directories for the subject property. City directories are used for locating individuals and businesses in a particular urban or suburban area. City directories are generally divided into three sections: a business index, a list of resident names and addresses, the name and type of businesses (if unclear from the name). While city directory coverage is comprehensive for major cities, it may be spotty for rural and small towns.

Polk City Directories: The Polk City Directories for the years 1965 and 1983 were reviewed. No listings were found for the subject property.

4.2.5 Historic Topographic Maps

Historic topographic maps (1907, 1940, 1947, 1957, 1976, and 2012), USGS 7.5 Min. Bonds Corner, CA Quadrangle, showed the subject property as being undeveloped (Appendix D). The All American Canal was not present in the 1907 topographic map, but appears in the 1940 map. The canal was constructed in the 1930s as part of the US Bureau of Reclamation – Boulder Canyon Project.

4.2.6 Historical Telephone Directories

Telephone Directories: Telephone directories for the Imperial County, which included the City of Calexico businesses published in 1941, 1955, 1965, 1974, 1994, and 2004 were reviewed. No service stations, chemical or petroleum manufacturers, distributors, or automotive repair facilities were noted at or in the immediate vicinity of the subject site.

4.3 Historical Use Summary

4.3.1 Summary of the Historical Use of Property

Based on a review of the historical information, the western portion of the subject property was first developed prior to 1937 for agricultural use, but has been fallow since at least 1937. The eastern portion of the subject site has been vacant desert land until about 1980 when a center-pivot irrigation system was installed and a circular agricultural field was developed.

4.3.2 Summary of the Historical Use of Adjacent Properties

Historically, the properties located immediately adjacent to the subject property have been comprised of vacant desert land to the east, the Republic of Mexico to the south, and the All American Canal and agricultural fields to the north.

5.0 SITE RECONNAISSANCE

5.1 Methodology and Limiting Conditions

A site reconnaissance was performed by Mr. Steven Williams, a consulting geologist to GS Lyon Consultants, on September 22, 2020. The site visit consisted of a driving the perimeter of the subject property and randomly crossing the subject property. The reconnaissance included visual observations of surficial conditions at the subject property and observation of adjoining properties to the extent that they were visible from public areas. Mr. Williams was accompanied during the site reconnaissance by Ramon Gonzalez, a representative for Apex Energy Solutions, LLC.

The site reconnaissance was limited to visual and/or physical observation of the exterior and interior of the subject property and its improvements, the current uses of the property and adjoining properties, and the current condition of the property. The site visit evaluated the subject property and adjoining properties for potential hazardous materials/waste and petroleum product use, storage, disposal, or accidental release, including the following: presence of tank and drum storage; mechanical or electrical equipment likely to contain liquids; evidence of soil or pavement staining or stressed vegetation; ponds, pits, lagoons, or sumps; suspicious odors; fill and depressions; or any other condition indicative of potential contamination. The site visit did not evaluate the presence of asbestos-containing materials, radon, lead-based paint, mold, indoor air quality, or structural defects, or other non-scope items.

A site reconnaissance can be limited by weather conditions, bodies of water, adjacent buildings, or other obstacles. The weather was warm and sunny and no access limitations were placed on the site visit.

5.2 General Site Setting

The subject property currently consists of approximately 530 acres comprised of three parcels (APNs 059-299-010, 059-300-017, and 059-300-015). The subject property is roughly triangular in plan view with the All American Canal forming the northern boundary, the International Border with the Republic of Mexico forming the southern boundary and vacant desert land forming the eastern boundary. The majority of the subject site has been cleared of desert vegetation for agricultural use. The western wedge and a small area in the north-central portion of the site are heavily vegetated.

A farm yard is located in the north-central portion of the subject site. A small masonry building housing water pumps, an above ground fuel storage tank (AST) and a storage building, all located within a chain-link fenced area comprise the farm yard. A bank of pole mounted transformers is located on the embankment of the All American Canal adjacent to the farm yard. A small equipment storage area with a disk, a trap wagon, and other miscellaneous farm implements is located northeast of the farm yard area. There are two central-pivot sprinklers that are located in the central portion of the site.

Photographs of the subject property taken on September 22, 2020 during our site reconnaissance are included in Appendix A.

5.3 Adjacent Properties

The subject property is located within a mixed agricultural and undeveloped desert area south of Holtville, California. Adjacent properties consist of the International Border with the Republic of Mexico along the southern boundary of the subject site and the All American Canal along the northern margin of the subject site.

5.4 Exterior and Interior Observations

The following conditions were specifically assessed for their potential to indicate RECs and may include conditions inside or outside structures on the subject property.

5.4.1 Hazardous Substances and Petroleum Products

GS Lyon did not observe operations that use, treat, store, dispose of, or generate hazardous materials or petroleum products on the subject property.

5.4.2 Storage Tanks

Underground Storage Tanks (USTs) – No obvious visual evidence indicating the current presence of USTs (i.e. vent pipes, fill ports, etc.) was noted.

Aboveground Storage Tanks (ASTs) – One (1) above ground fuel tank (AST) was observed within the fenced farm yard. Access to the tank was not available to determine if it contained fuel.

5.4.3 Odors

No obvious strong, pungent, or noxious odors were noted during the site reconnaissance.

5.4.4 Pools of Liquid

Pools of liquid were not observed during the site reconnaissance.

5.4.5 Drums and Containers

GS Lyon observed several steel 55-gallon drums on the subject property. No fluids were observed in the drums that were accessible.

5.4.6 Unidentified Substance Containers

GS Lyon did not observe open or damaged containers containing unidentified substances at the subject property.

5.4.7 Suspect Polychlorinated Biphenyl (PCB) Containing Equipment

Pole-mounted sealed electrical transformers owned and maintained by the Imperial Irrigation District (IID) are located on the embankment of the All American Canal adjacent to the farm yard on the subject property. In recent years, the IID has replaced all transformers that contained PCBs. Stickers were observed on the transformers that indicated that they had been tested for PCBs. No leaks were noted during our site visit.

5.5 Interior Observations

Access to the pump building within the fenced farm yard was not obtainable; therefore, interior observations were not made of the structure.

5.6 Exterior Observations

5.6.1 Pits, Ponds, and Lagoons

No pits, ponds, or lagoons were noted on the subject property.

5.6.2 Stained Soils or Pavement

No evidence of significantly stained soil or pavement was noted on the subject property.

5.6.3 Stressed Vegetation

No evidence of stressed vegetation attributed to potential contamination was noted on the subject property.

5.6.4 Solid Waste

No dumpsters or solid waste containers exist on the subject property.

5.6.5 Wastewater

No wastewater is generated at the subject property.

5.6.6 Wells

No evidence of wells (dry wells, drinking water, observation wells, groundwater monitoring wells, irrigation wells, injection wells or abandoned wells) was noted on the subject property. Water for the center-pivot sprinkler system was supplied from the All American Canal.

5.6.7 Septic Systems

No septic systems are present on the subject property.

5.7 Non-Scope Issues

ASTM guidelines identify non-scope issues, which are beyond the scope of a Phase I ESA as defined by ASTM. These issues may affect environmental risk at the subject property and may warrant discussion and/or assessment. Some of these non-scope issues include; asbestos-containing building materials, radon, lead-based paint, and wetlands which are discussed below.

5.7.1 Asbestos-Containing Building Materials

The potential for asbestos containing materials (ACM) existing at the subject property is low due to the lack of structures other than the small masonry structure at the farm yard.

5.7.2 Lead-Based Paint

The potential or lead based paint residues existing at the subject property is very low due to the lack of development other than the small masonry structure at the farm yard.

5.7.3 Radon

The subject property is located in Zone 3 as shown on the EPA Map of Radon Zones indicating a predicted average indoor radon screening level of less than 2 pCi/L. Radon gas is not believed to be a potential hazard at the subject property.

5.7.4 Agricultural Use

Based on our review of environmental records, historical documents, and subject property conditions, the property has been in agricultural use and/or vacant since the 1930's. Residues of currently available pesticides and currently banned pesticides such as DDT/DDE may be present in near surface soils in limited concentrations. The concentrations of these pesticides found on other Imperial Valley agricultural sites are typically less than 25% of the current regulatory threshold limits and, at those levels, are not considered a significant environmental hazard. The presence and concentration of near surface pesticides at this subject property can be accurately characterized only by site-specific sampling and testing.

6.0 INTERVIEWS

GS Lyon interviewed various individuals familiar with the subject property, as identified to us, and/or government officials in order to evaluate historical uses and identify potential RECs existing on the subject property. The individuals interviewed were asked to provide responses in good faith and to the best of their knowledge. The following sections identify the individuals interviewed and summarize the information each provided; however, additional information provided by these individuals may be presented in other sections of this report.

Interviews with past owners, operators and occupants were not reasonably ascertainable and thus constitute a data gap.

6.1 Interview with Owner

GS Lyon we not able to contact the current property owner; therefore, no interview was conducted.

6.2 Interview with the Site Manager

The subject property is vacant, undeveloped land; therefore, there is no site manager.

6.3 Interview with Occupants

The subject property is vacant, undeveloped land; therefore, there are no occupants.

6.4 Interview with Local Government Officials

The DTSC Imperial CUPA office was contacted (Veronica Lopez) by email on September 9, 2020. CUPA records were searched for environmental issues related to the subject property. The DTSC indicated that records are filed per address, and with no known address associated with the subject property, no records were found associated with the subject property.

7.0 EVALUATION

7.1 Summary of Findings

The subject property is located in an area generally developed for agricultural use east of Calexico, California. The western portion of the subject property has been developed as agricultural use since at least the 1930s according to the historical information obtained and reviewed during this site assessment. The eastern portion of the site was vacant desert land until about 1980 when a portion was developed for agricultural use.

7.2 Conclusions

GS Lyon has performed a Phase I Environmental Site Assessment in general conformance with the scope and limitations of ASTM E1527-13 of the approximately 530-acre property located on the south side of the All American Canal at Bonesteele Road approximately 10 miles south of Holtville, California. Any exceptions to, or deviations from, this practice are described in Section 1.4 of this Phase I ESA report. This assessment has revealed the following recognized environmental conditions (RECs) in connection with the subject property:

7.2.1 Recognized Environmental Conditions

A *recognized environmental condition (REC)* refers to the presence or likely presence of any hazardous substances or petroleum products in, on, or at a property: (1) due to any release to the environment; (2) under conditions indicative of a release to the environment; or (3) under conditions that pose a material threat of a future release to the environment. under conditions that indicate an existing release, a past release, or a material threat of a release of any hazardous substances or petroleum products into structures on the property or into the ground, groundwater, or surface water of the property. The term REC includes hazardous substances and petroleum products even under conditions that might be in compliance with laws. The term is not intended to include "de minimis" conditions as defined in Section 7.2.3 of this report.

This Phase I ESA has revealed no evidence of *recognized environmental conditions* in connection with the subject property.

7.2.2 Historical Recognized Environmental Conditions

A *historical recognized environmental condition (HREC)* refers to a past *release* of any *hazardous substances* or *petroleum products* that has occurred in connection with the *property* and has been addressed to the satisfaction of the applicable regulatory authority or meeting unrestricted use criteria established by a regulatory authority, without subjecting the *property* to any required controls (for example, *property* use restrictions, *activity and use limitations*, *institutional controls*, or *engineering controls*).

This Phase I ESA has revealed no evidence of *historical recognized environmental conditions* in connection with the subject property.

7.2.3 Environmental Concerns and De Minimis Conditions

A *de minimis condition* is a condition that generally does not present a threat to human health or the *environment* and that generally would not be the subject of an enforcement action if brought to the attention of appropriate governmental agencies. Conditions determined to be *de minimis conditions* are not *recognized environmental conditions* nor *controlled recognized environmental conditions*.

This Phase I ESA has revealed the following *de minimis* conditions or environmental concerns in connection with the subject property:

1. Pole-mounted sealed electrical transformers owned and maintained by the Imperial Irrigation District (IID) exist on the margin of this subject property. All IID transformers containing PCB's have been replaced. ***If the transformers begin to leak, the IID should be notified and the transformers replaced.***
2. An aboveground fuel tank is located within the fenced farm yard area. If it is shown that spills or leaks had occurred, the affected soil should be cleaned up and properly disposed.

7.3 Recommendations

Based on the scope of work performed for this assessment, it is our professional opinion that no RECs have been identified in connection with the subject property that would warrant further environmental study (Phase II) at this time.

8.0 REFERENCES

40 CFR 312, Standards and Practices for All Appropriate Inquiries; Final Rule, November 2005 (AAI Rule).

American Society for Testing and Materials. 2013. Standard Practice for Environmental Site Assessments: Phase I Environmental Site Assessment Process. Designation E 1527-13. West Conshohocken, Pennsylvania. 35 pp.

Department of Toxic Substances Control. 2020. EnviroStor Database Website, <http://www.envirostor.dtsc.ca.gov/public/> .

Environmental Data Resources, Inc., *The EDR Radius Map with Geocheck*. Inquiry number 6171645, dated August 28, 2020

Environmental Data Resources, Inc., *EDR Historical Topographic Map Report*. Inquiry number 6171645, dated August 28, 2020

Environmental Data Resources, Inc., *The EDR Aerial Photo Decade Package*. Inquiry number 6171645, dated August 28, 2020

State Water Resources Control Board. 2020. GeoTracker Database Website, <http://geotracker.swrcb.ca.gov/>

United States Department of Agriculture, Natural Resources Conservation Service, Web Soil Survey, accessed via the Internet, September 2020

United States Environmental Protection Agency, EPA Map of Radon Zones (Document EPA-402-R-93-071), accessed via the Internet, September 2020

United States Geological Survey Topographic Map 1997, 7.5 minute series

APPENDIX A

PC ORIGINAL PKG



Photo 1: Looking northeast along the northern boundary of the subject site.



Photo 2: View of center-pivot sprinkler near the north-central portion of the site.



Photo 3: Masonry block pump house located at the north-central portion of the subject site.



Photo 4: Clos-up view of pump house and transformer bank.



Photo 5: Above ground fuel tank (AST) within farm yard.



Photo 6: Miscellaneous building near farm yard.



Photo 7: Farm equipment storage area east of farm yard.



Photo 8: Close-up view of farm equipment.



Photo 9: Close-up view of transformer bank. IID stickers show the transformers have been tested for PCBs.



Photo 10: Looking east across the site from the west margin of the subject site.



Photo 11: Looking south along the west margin of the subject site.



Photo 12: Looking east along the southern boundary of the subject site.



Photo 13: Looking west from the east-central portion of the subject site.



Photo 14: Looking north across the subject property.



Photo 15: Looking north from the southeast corner of the subject site.

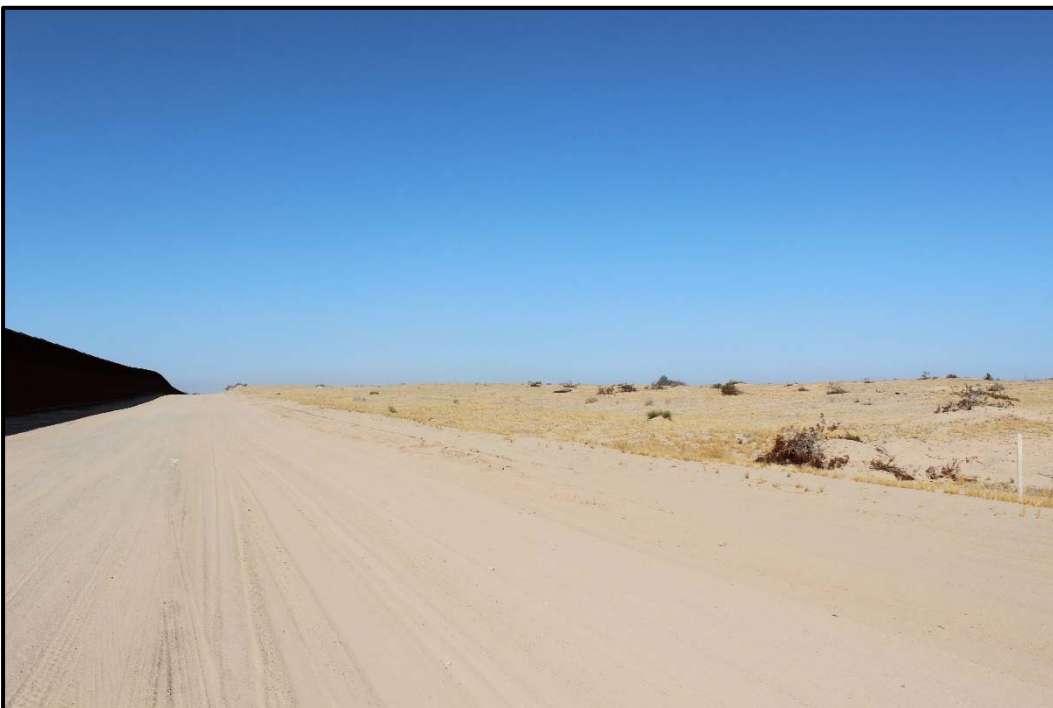
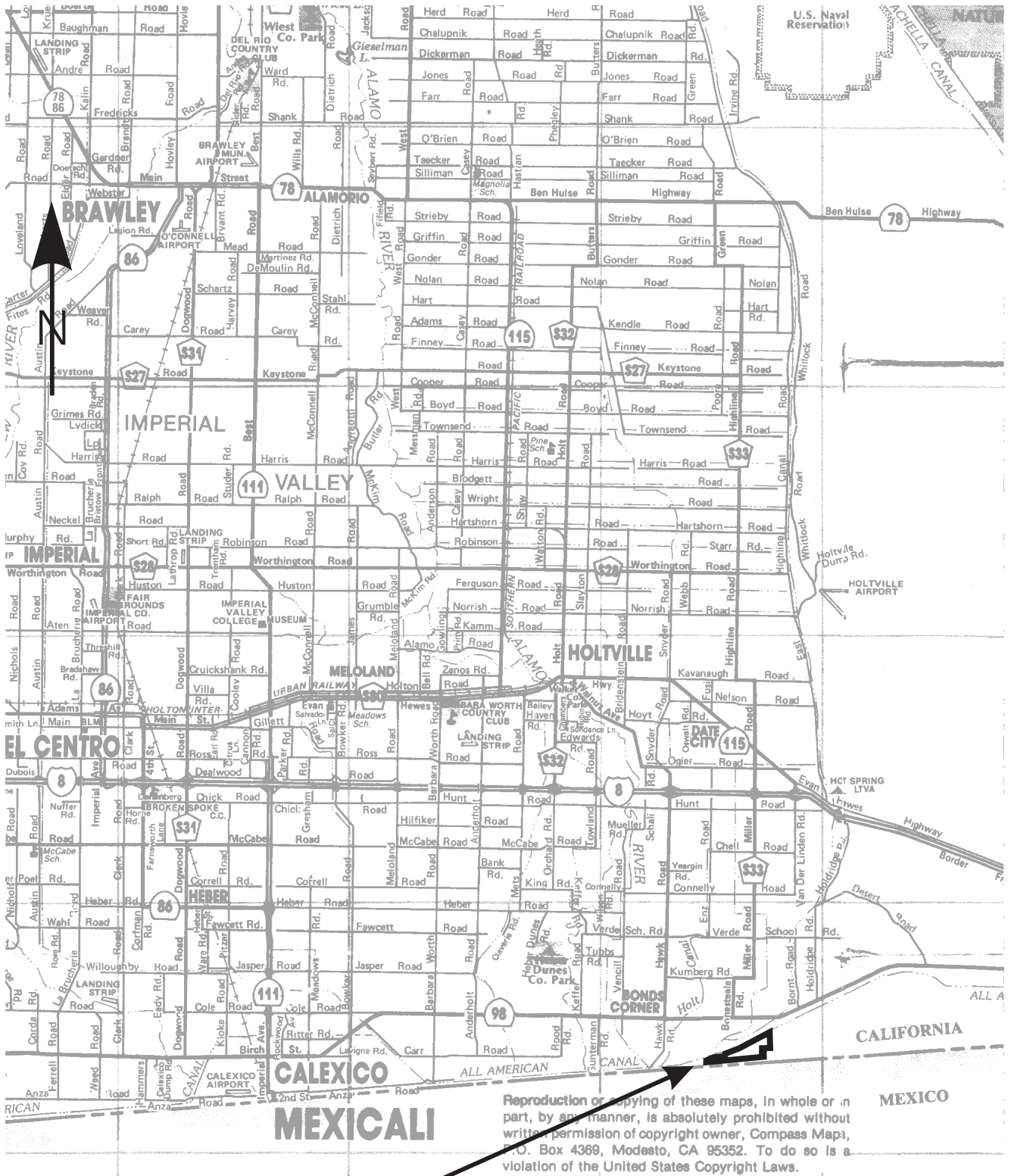


Photo 16: Looking west along the southern margin of the subject property. The United States border fence and Border Patrol road on left side of the photo.

APPENDIX B

PC ORIGINAL PKG



Reproduction or copying of these maps, in whole or in part, by any manner, is absolutely prohibited without written permission of copyright owner, Compass Maps, P.O. Box 4369, Modesto, CA 95352. To do so is a violation of the United States Copyright Laws.

Subject Site

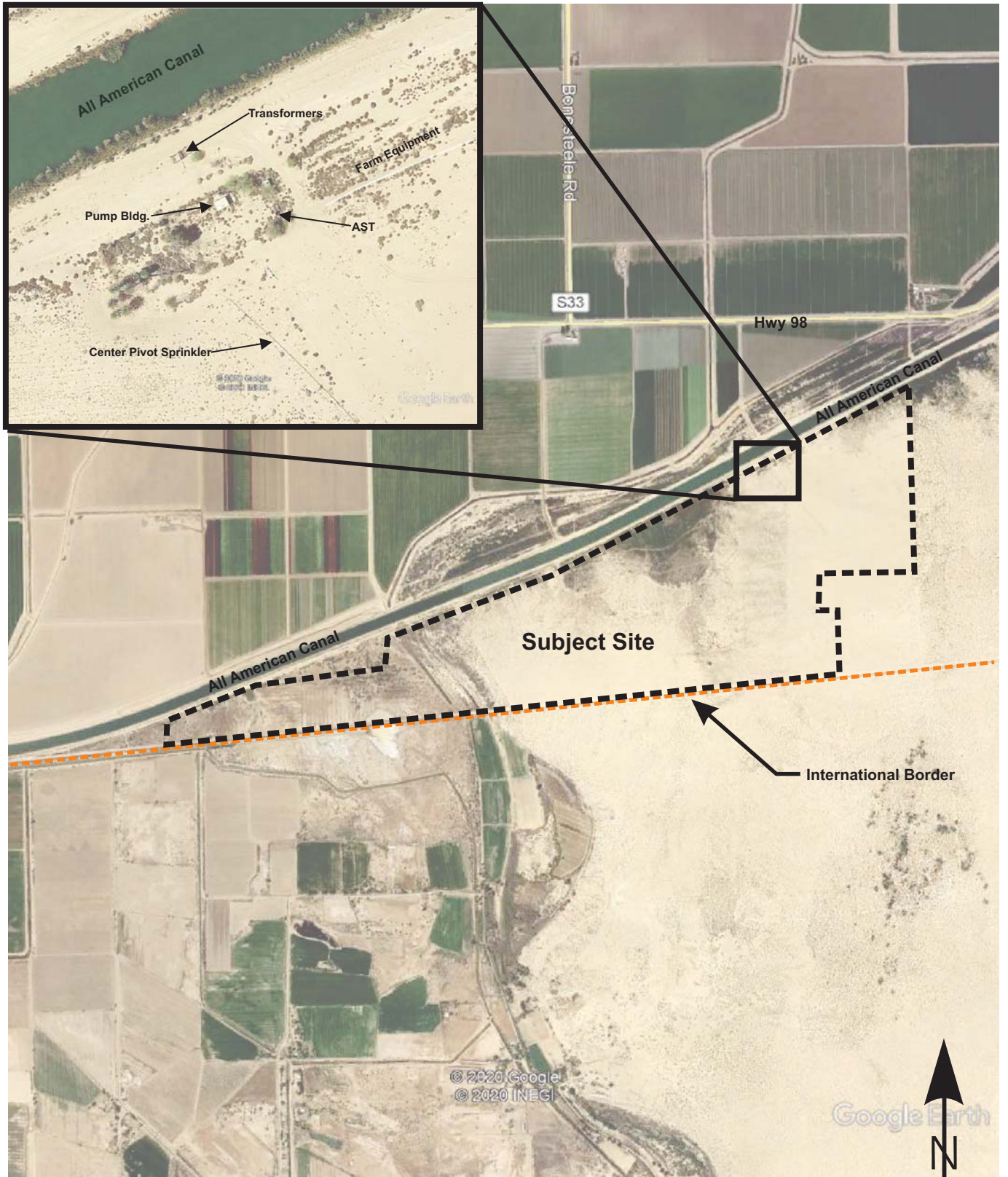


Project No.: GS2015

Vicinity Map

Plate
1

PC ORIGINAL PKG



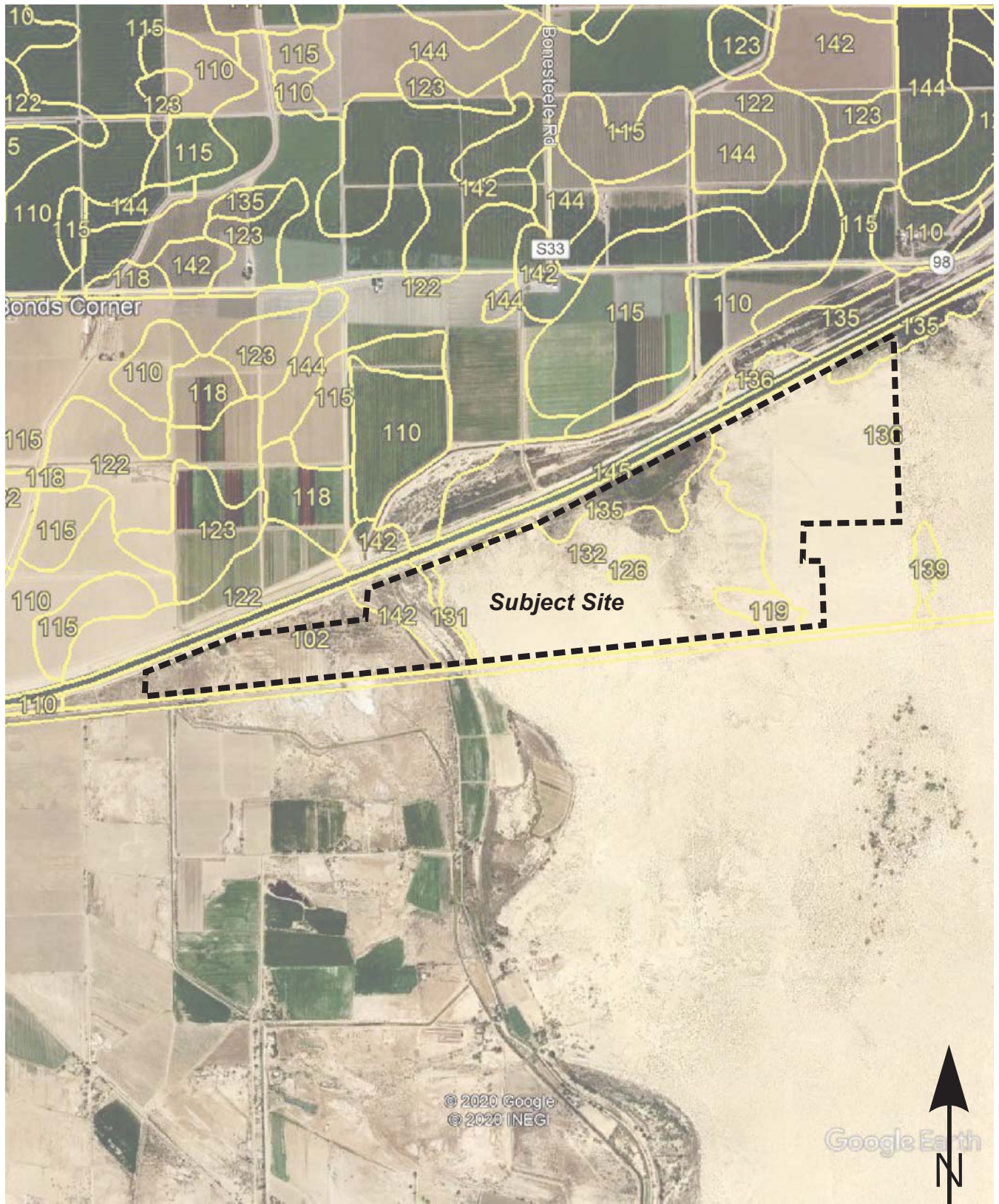
GS Lyon

Project No.: GS2015

Site Map

Plate
2

PC ORIGINAL PKG



© 2020 Google
© 2020 INEG



GS Lyon

Project No.: GS2015

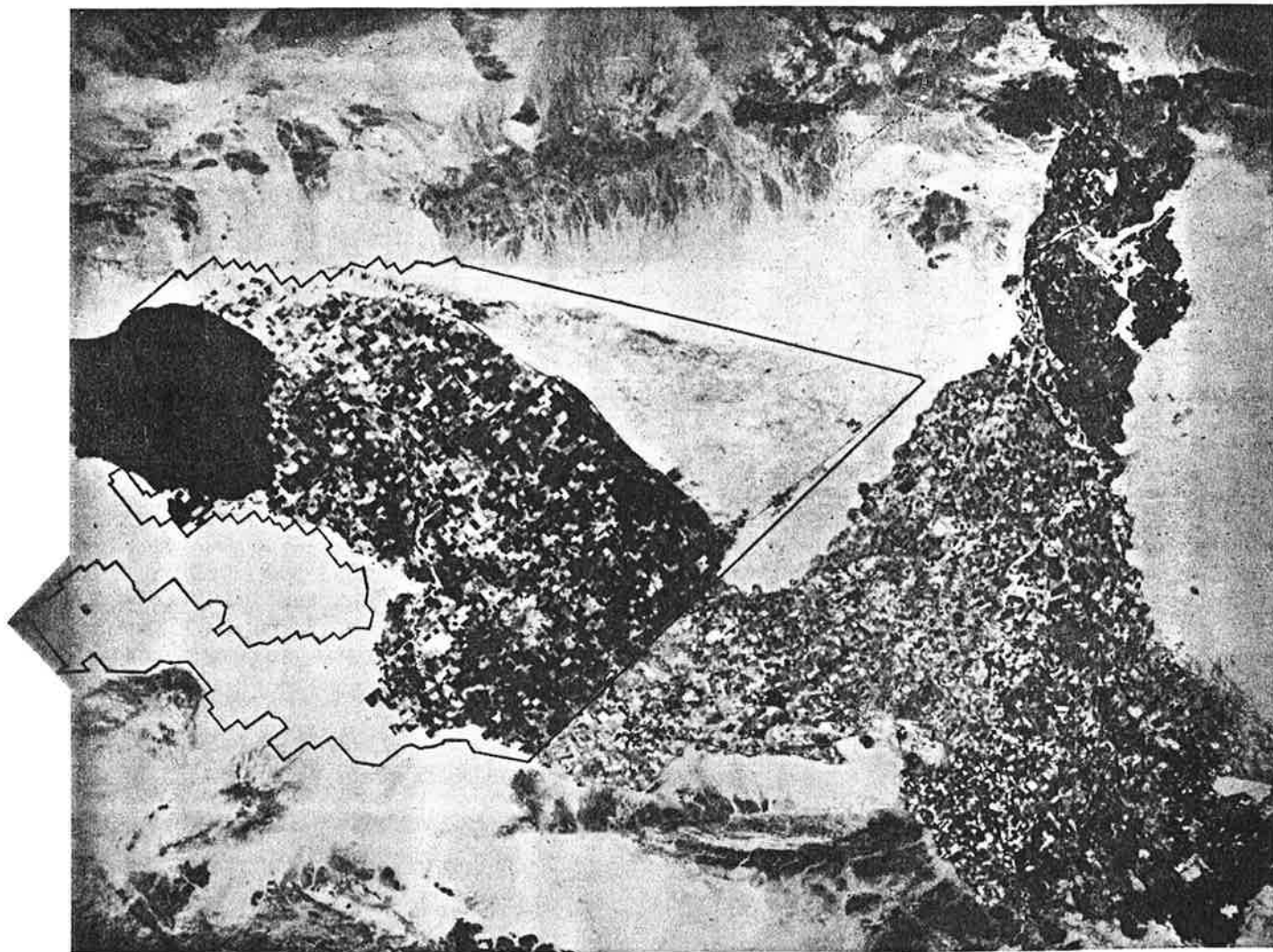
Soil Survey Map

Plate
3

PC ORIGINAL PKG

Soil Survey of

**IMPERIAL COUNTY
CALIFORNIA
IMPERIAL VALLEY AREA**



United States Department of Agriculture Soil Conservation Service
in cooperation with
University of California Agricultural Experiment Station
and
Imperial Irrigation District

PC ORIGINAL PKG

TABLE 11.--ENGINEERING INDEX PROPERTIES

[The symbol > means more than. Absence of an entry indicates that data were not estimated]

Soil name and map symbol	Depth	USDA texture	Classification		Frag-ments > 3 inches	Percentage passing sieve number--				Liquid limit	Plas-ticity index
			Unified	AASHTO		4	10	40	200		
	In				Pct					Pct	
100-----	0-13	Loamy fine sand	SM	A-2	0	100	100	75-85	10-30	---	NP
Antho	13-60	Sandy loam, fine sandy loam.	SM	A-2, A-4	0	90-100	75-95	50-60	15-40	---	NP
101*:											
Antho-----	0-8	Loamy fine sand	SM	A-2	0	100	100	75-85	10-30	---	NP
	8-60	Sandy loam, fine sandy loam.	SM	A-2, A-4	0	90-100	75-95	50-60	15-40	---	NP
Superstition-----	0-6	Fine sand-----	SM	A-2	0	100	95-100	70-85	15-25	---	NP
	6-60	Loamy fine sand, fine sand, sand.	SM	A-2	0	100	95-100	70-85	15-25	---	NP
102*.											
Badland											
103-----	0-10	Gravelly sand---	SP, SP-SM	A-1, A-2	0-5	60-90	50-85	30-55	0-10	---	NP
Carsitas	10-60	Gravelly sand, gravelly coarse sand, sand.	SP, SP-SM	A-1	0-5	60-90	50-85	25-50	0-10	---	NP
104*											
Fluvaquents											
105-----	0-13	Clay loam-----	CL	A-6	0	100	100	90-100	70-95	35-45	15-30
Glenbar	13-60	Clay loam, silty clay loam.	CL	A-6	0	100	100	90-100	70-95	35-45	15-30
106-----	0-13	Clay loam-----	CL	A-6, A-7	0	100	100	90-100	70-95	35-45	15-25
Glenbar	13-60	Clay loam, silty clay loam.	CL	A-6, A-7	0	100	100	90-100	70-95	35-45	15-25
107*-----	0-13	Loam-----	ML, CL-ML, CL	A-4	0	100	100	100	70-80	20-30	NP-10
Glenbar	13-60	Clay loam, silty clay loam.	CL	A-6, A-7	0	100	100	95-100	75-95	35-45	15-30
108-----	0-14	Loam-----	ML	A-4	0	100	100	85-100	55-95	25-35	NP-10
Holtville	14-22	Clay, silty clay	CL, CH	A-7	0	100	100	95-100	85-95	40-65	20-35
	22-60	Silt loam, very fine sandy loam.	ML	A-4	0	100	100	95-100	65-85	25-35	NP-10
109-----	0-17	Silty clay-----	CL, CH	A-7	0	100	100	95-100	85-95	40-65	20-35
Holtville	17-24	Clay, silty clay	CL, CH	A-7	0	100	100	95-100	85-95	40-65	20-35
	24-35	Silt loam, very fine sandy loam.	ML	A-4	0	100	100	95-100	65-85	25-35	NP-10
	35-60	Loamy very fine sand, loamy fine sand.	SM, ML	A-2, A-4	0	100	100	75-100	20-55	---	NP
110-----	0-17	Silty clay-----	CH, CL	A-7	0	100	100	95-100	85-95	40-65	20-35
Holtville	17-24	Clay, silty clay	CH, CL	A-7	0	100	100	95-100	85-95	40-65	20-35
	24-35	Silt loam, very fine sandy loam.	ML	A-4	0	100	100	95-100	55-85	25-35	NP-10
	35-60	Loamy very fine sand, loamy fine sand.	SM, ML	A-2, A-4	0	100	100	75-100	20-55	---	NP

See footnote at end of table.

TABLE 11.--ENGINEERING INDEX PROPERTIES--Continued

Soil name and map symbol	Depth	USDA texture	Classification		Frag-ments > 3 inches Pct	Percentage passing sieve number--				Liquid limit Pct	Plas-ticity index
			Unified	AASHTO		4	10	40	200		
111*: Holtville-----	0-10	Silty clay loam	CL, CH	A-7	0	100	100	95-100	85-95	40-65	20-35
	10-22	Clay, silty clay	CL, CH	A-7	0	100	100	95-100	85-95	40-65	20-35
	22-60	Silt loam, very fine sandy loam.	ML	A-4	0	100	100	95-100	65-85	25-35	NP-10
Imperial-----	0-12	Silty clay loam	CL	A-7	0	100	100	100	85-95	40-50	10-20
	12-60	Silty clay loam, silty clay, clay.	CH	A-7	0	100	100	100	85-95	50-70	25-45
112-----	0-12	Silty clay-----	CH	A-7	0	100	100	100	85-95	50-70	25-45
Imperial	12-60	Silty clay loam, silty clay, clay.	CH	A-7	0	100	100	100	85-95	50-70	25-45
113-----	0-12	Silty clay-----	CH	A-7	0	100	100	100	85-95	50-70	25-45
Imperial	12-60	Silty clay, clay, silty clay loam.	CH	A-7	0	100	100	100	85-95	50-70	25-45
114-----	0-12	Silty clay-----	CH	A-7	0	100	100	100	85-95	50-70	25-45
Imperial	12-60	Silty clay loam, silty clay, clay.	CH	A-7	0	100	100	100	85-95	50-70	25-45
115*: Imperial-----	0-12	Silty clay loam	CL	A-7	0	100	100	100	85-95	40-50	10-20
	12-60	Silty clay loam, silty clay, clay.	CH	A-7	0	100	100	100	85-95	50-70	25-45
Glenbar-----	0-13	Silty clay loam	CL	A-6, A-7	0	100	100	90-100	70-95	35-45	15-25
	13-60	Clay loam, silty clay loam.	CL	A-6, A-7	0	100	100	90-100	70-95	35-45	15-25
116*: Imperial-----	0-13	Silty clay loam	CL	A-7	0	100	100	100	85-95	40-50	10-20
	13-60	Silty clay loam, silty clay, clay.	CH	A-7	0	100	100	100	85-95	50-70	25-45
Glenbar-----	0-13	Silty clay loam	CL	A-6, A-7	0	100	100	90-100	70-95	35-45	15-25
	13-60	Clay loam, silty clay loam.	CL	A-6	0	100	100	90-100	70-95	35-45	15-30
117, 118-----	0-12	Loam-----	ML	A-4	0	95-100	95-100	85-100	75-90	20-30	NP-5
Indio	12-72	Stratified loamy very fine sand to silt loam.	ML	A-4	0	95-100	95-100	85-100	75-90	20-30	NP-5
119*: Indio-----	0-12	Loam-----	ML	A-4	0	95-100	95-100	85-100	75-90	20-30	NP-5
	12-72	Stratified loamy very fine sand to silt loam.	ML	A-4	0	95-100	95-100	85-100	75-90	20-30	NP-5
Vint-----	0-10	Loamy fine sand	SM	A-2	0	95-100	95-100	70-80	25-35	---	NP
	10-60	Loamy sand, loamy fine sand.	SM	A-2	0	95-100	95-100	70-80	20-30	---	NP
120*: Laveen-----	0-12	Loam-----	ML, CL-ML	A-4	0	100	95-100	75-85	55-65	20-30	NP-10
	12-60	Loam, very fine sandy loam.	ML, CL-ML	A-4	0	95-100	85-95	70-80	55-65	15-25	NP-10

See footnote at end of table.

TABLE 11.--ENGINEERING INDEX PROPERTIES--Continued

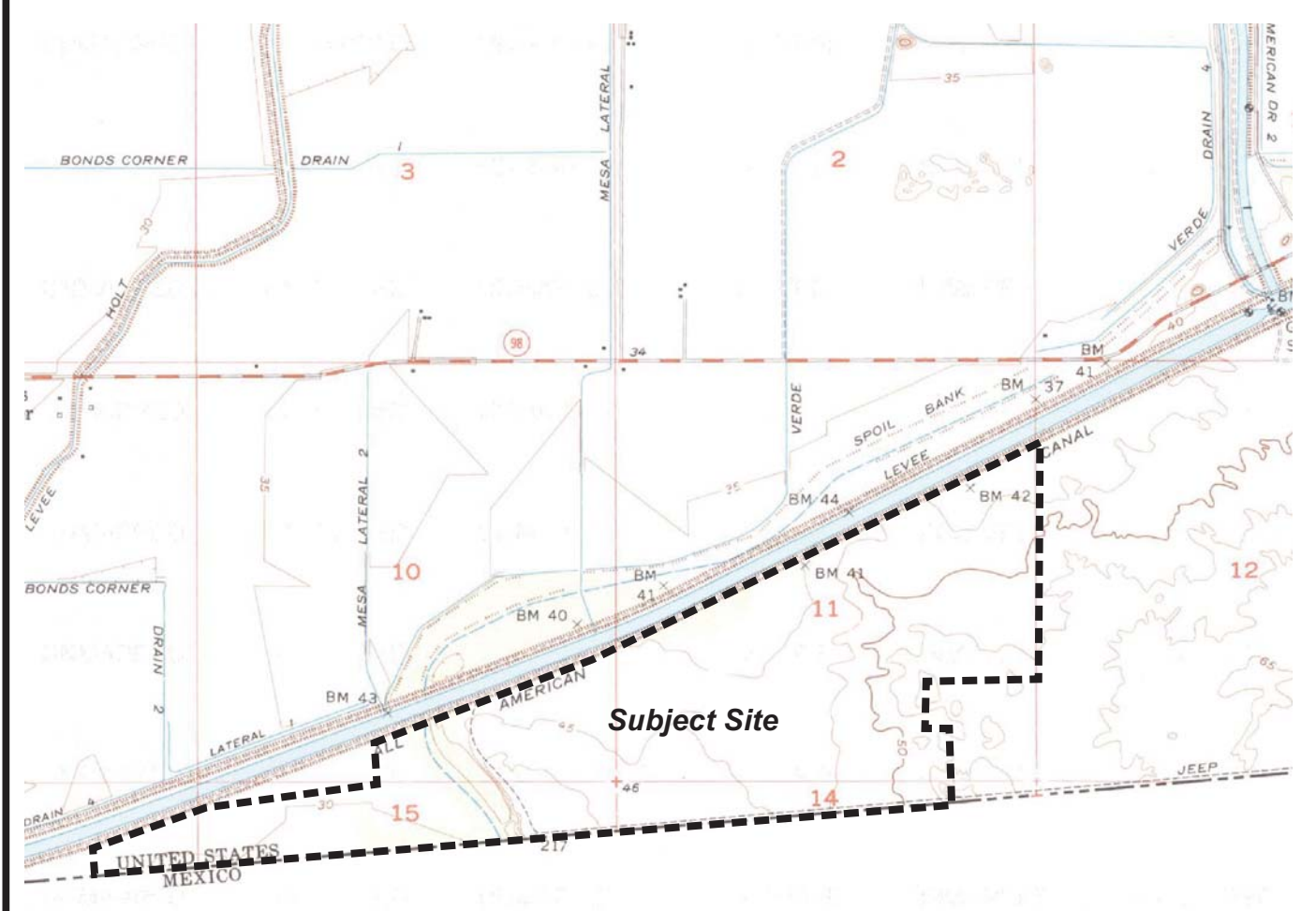
Soil name and map symbol	Depth In	USDA texture	Classification		Frag- ments > 3 inches Pct	Percentage passing sieve number--				Liquid limit Pet	Plas- ticity index
			Unified	AASHTO		4	10	40	200		
121----- Meloland	0-12	Fine sand-----	SM, SP-SM	A-2, A-3	0	95-100	90-100	75-100	5-30	---	NP
	12-26	Stratified loamy fine sand to silt loam.	ML	A-4	0	100	100	90-100	50-65	25-35	NP-10
	26-71	Clay, silty clay, silty clay loam.	CL, CH	A-7	0	100	100	95-100	85-95	40-65	20-40
122----- Meloland	0-12	Very fine sandy loam.	ML	A-4	0	95-100	95-100	95-100	55-85	25-35	NP-10
	12-26	Stratified loamy fine sand to silt loam.	ML	A-4	0	100	100	90-100	50-70	25-35	NP-10
	26-71	Clay, silty clay, silty clay loam.	CH, CL	A-7	0	100	100	95-100	85-95	40-65	20-40
123*: Meloland-----	0-12	Loam-----	ML	A-4	0	95-100	95-100	95-100	55-85	25-35	NP-10
	12-26	Stratified loamy fine sand to silt loam.	ML	A-4	0	100	100	90-100	50-70	25-35	NP-10
	26-38	Clay, silty clay, silty clay loam.	CH, CL	A-7	0	100	100	95-100	85-95	40-65	20-40
	38-60	Stratified silt loam to loamy fine sand.	SM, ML	A-4	0	100	100	75-100	35-55	25-35	NP-10
Holtville-----	0-12	Loam-----	ML	A-4	0	100	100	85-100	55-95	25-35	NP-10
	12-24	Clay, silty clay	CH, CL	A-7	0	100	100	95-100	85-95	40-65	20-35
	24-36	Silt loam, very fine sandy loam.	ML	A-4	0	100	100	95-100	55-85	25-35	NP-10
	36-60	Loamy very fine sand, loamy fine sand.	SM, ML	A-2, A-4	0	100	100	75-100	20-55	---	NP
124, 125----- Niland	0-23	Gravelly sand---	SM, SP-SM	A-2, A-3	0	90-100	70-95	50-65	5-25	---	NP
	23-60	Silty clay, clay, clay loam.	CL, CH	A-7	0	100	100	85-100	80-95	40-65	20-40
126----- Niland	0-23	Fine sand-----	SM, SP-SM	A-2, A-3	0	90-100	90-100	50-65	5-25	---	NP
	23-60	Silty clay-----	CL, CH	A-7	0	100	100	85-100	80-95	40-65	20-40
127----- Niland	0-23	Loamy fine sand	SM	A-2	0	90-100	90-100	50-65	15-30	---	NP
	23-60	Silty clay-----	CL, CH	A-7	0	100	100	85-100	80-95	40-65	20-40
128*: Niland-----	0-23	Gravelly sand---	SM, SP-SM	A-2, A-3	0	90-100	70-95	50-65	5-25	---	NP
	23-60	Silty clay, clay, clay loam.	CL, CH	A-7	0	100	100	85-100	80-100	40-65	20-40
Imperial-----	0-12	Silty clay-----	CH	A-7	0	100	100	100	85-95	50-70	25-45
	12-60	Silty clay loam, silty clay, clay.	CH	A-7	0	100	100	100	85-95	50-70	25-45
129*: Pits											
130, 131----- Rositas	0-27	Sand-----	SP-SM	A-3, A-1, A-2	0	100	80-100	40-70	5-15	---	NP
	27-60	Sand, fine sand, loamy sand.	SM, SP-SM	A-3, A-2, A-1	0	100	80-100	40-85	5-30	---	NP

See footnote at end of table.

TABLE 11.--ENGINEERING INDEX PROPERTIES--Continued

Soil name and map symbol	Depth	USDA texture	Classification		Frag-ments > 3 inches	Percentage passing sieve number--				Liquid limit	Plas-ticity index
			Unified	AASHTO		4	10	40	200		
	In				Pct					Pct	
132, 133, 134, 135-Rositas	0-9	Fine sand-----	SM	A-3, A-2	0	100	80-100	50-80	10-25	---	NP
	9-60	Sand, fine sand, loamy sand.	SM, SP-SM	A-3, A-2, A-1	0	100	80-100	40-85	5-30	---	NP
136-----Rositas	0-4	Loamy fine sand	SM	A-1, A-2	0	100	80-100	40-85	10-35	---	NP
	4-60	Sand, fine sand, loamy sand.	SM, SP-SM	A-3, A-2, A-1	0	100	80-100	40-85	5-30	---	NP
137-----Rositas	0-12	Silt loam-----	ML	A-4	0	100	100	90-100	70-90	20-30	NP-5
	12-60	Sand, fine sand, loamy sand.	SM, SP-SM	A-3, A-2, A-1	0	100	80-100	40-85	5-30	---	NP
138*: Rositas-----	0-4	Loamy fine sand	SM	A-1, A-2	0	100	80-100	40-85	10-35	---	NP
	4-60	Sand, fine sand, loamy sand.	SM, SP-SM	A-3, A-2, A-1	0	100	80-100	40-85	5-30	---	NP
Superstition-----	0-6	Loamy fine sand	SM	A-2	0	100	95-100	70-85	15-25	---	NP
	6-60	Loamy fine sand, fine sand, sand.	SM	A-2	0	100	95-100	70-85	15-25	---	NP
139-----Superstition	0-6	Loamy fine sand	SM	A-2	0	100	95-100	70-85	15-25	---	NP
	6-60	Loamy fine sand, fine sand, sand.	SM	A-2	0	100	95-100	70-85	15-25	---	NP
140*: Torriorthents											
Rock outcrop											
141*: Torriorthents											
Orthids											
142-----Vint	0-10	Loamy very fine sand.	SM, ML	A-4	0	100	100	85-95	40-65	15-25	NP-5
	10-60	Loamy fine sand	SM	A-2	0	95-100	95-100	70-80	20-30	---	NP
143-----Vint	0-12	Fine sandy loam	ML, CL-ML, SM, SM-SC	A-4	0	100	100	75-85	45-55	15-25	NP-5
	12-60	Loamy sand, loamy fine sand.	SM	A-2	0	95-100	95-100	70-80	20-30	---	NP
144*: Vint-----	0-10	Very fine sandy loam.	SM, ML	A-4	0	100	100	85-95	40-65	15-25	NP-5
	10-40	Loamy fine sand	SM	A-2	0	95-100	95-100	70-80	20-30	---	NP
	40-60	Silty clay-----	CL, CH	A-7	0	100	100	95-100	85-95	40-65	20-35
Indio-----	0-12	Very fine sandy loam.	ML	A-4	0	95-100	95-100	85-100	75-90	20-30	NP-5
	12-40	Stratified loamy very fine sand to silt loam.	ML	A-4	0	95-100	95-100	85-100	75-90	20-30	NP-5
	40-72	Silty clay-----	CL, CH	A-7	0	100	100	95-100	85-95	40-65	20-35

* See description of the map unit for composition and behavior characteristics of the map unit.



GS Lyon
Project No.: GS2011

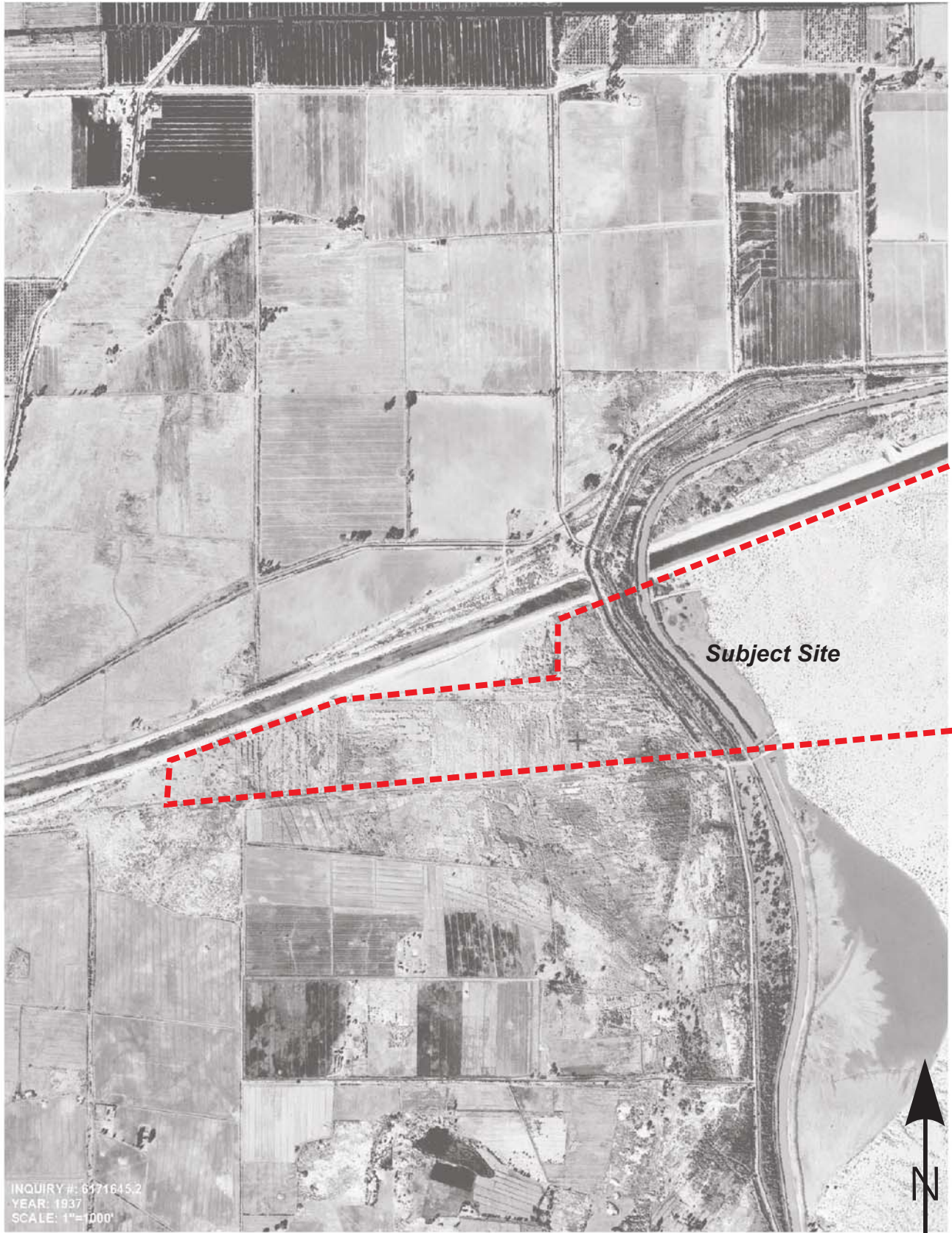
Topographic Map

Plate
4

PC ORIGINAL PKG

APPENDIX C

PC ORIGINAL PKG



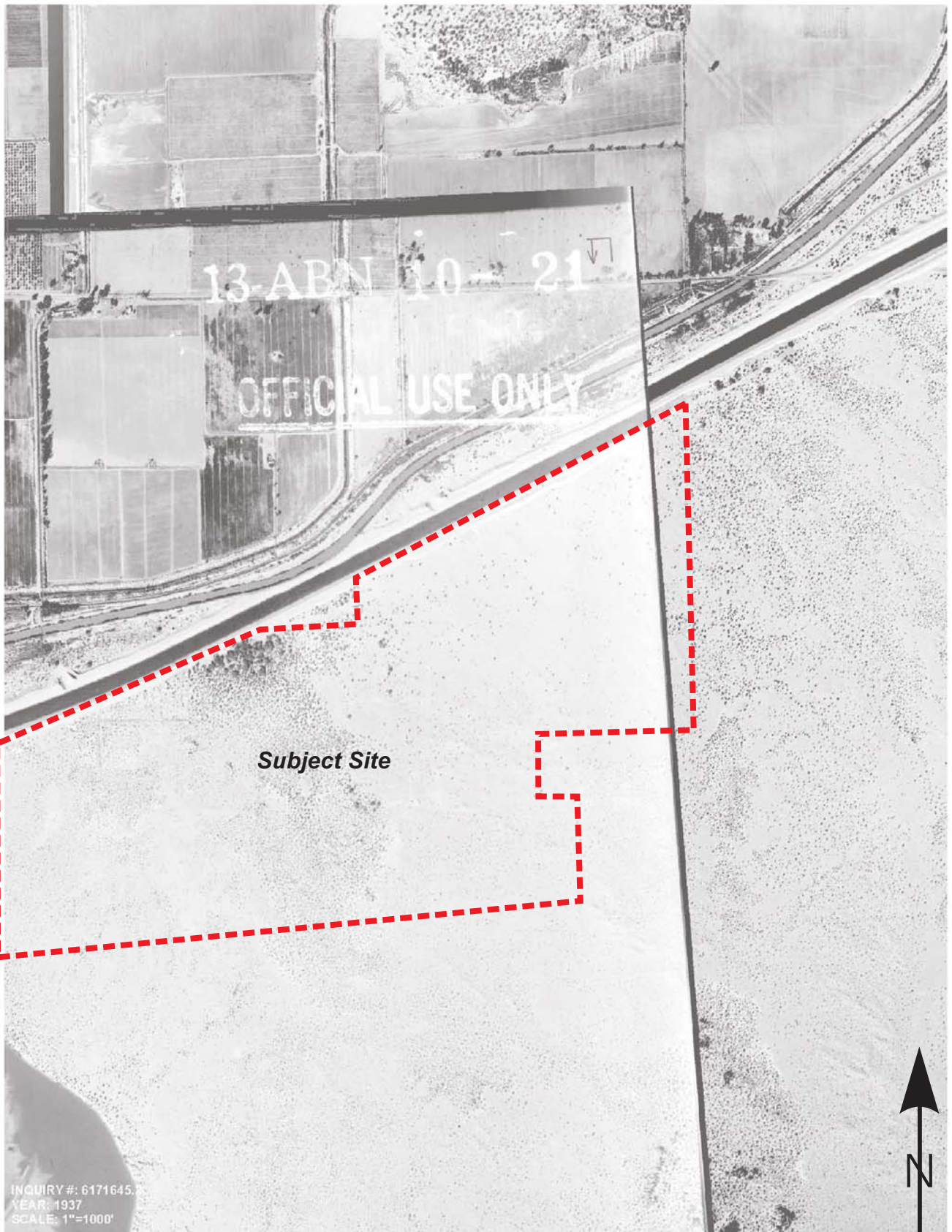
GS Lyon

Project No.: GS2015

1937 Aerial Photograph

Plate
5a

PC ORIGINAL PKG



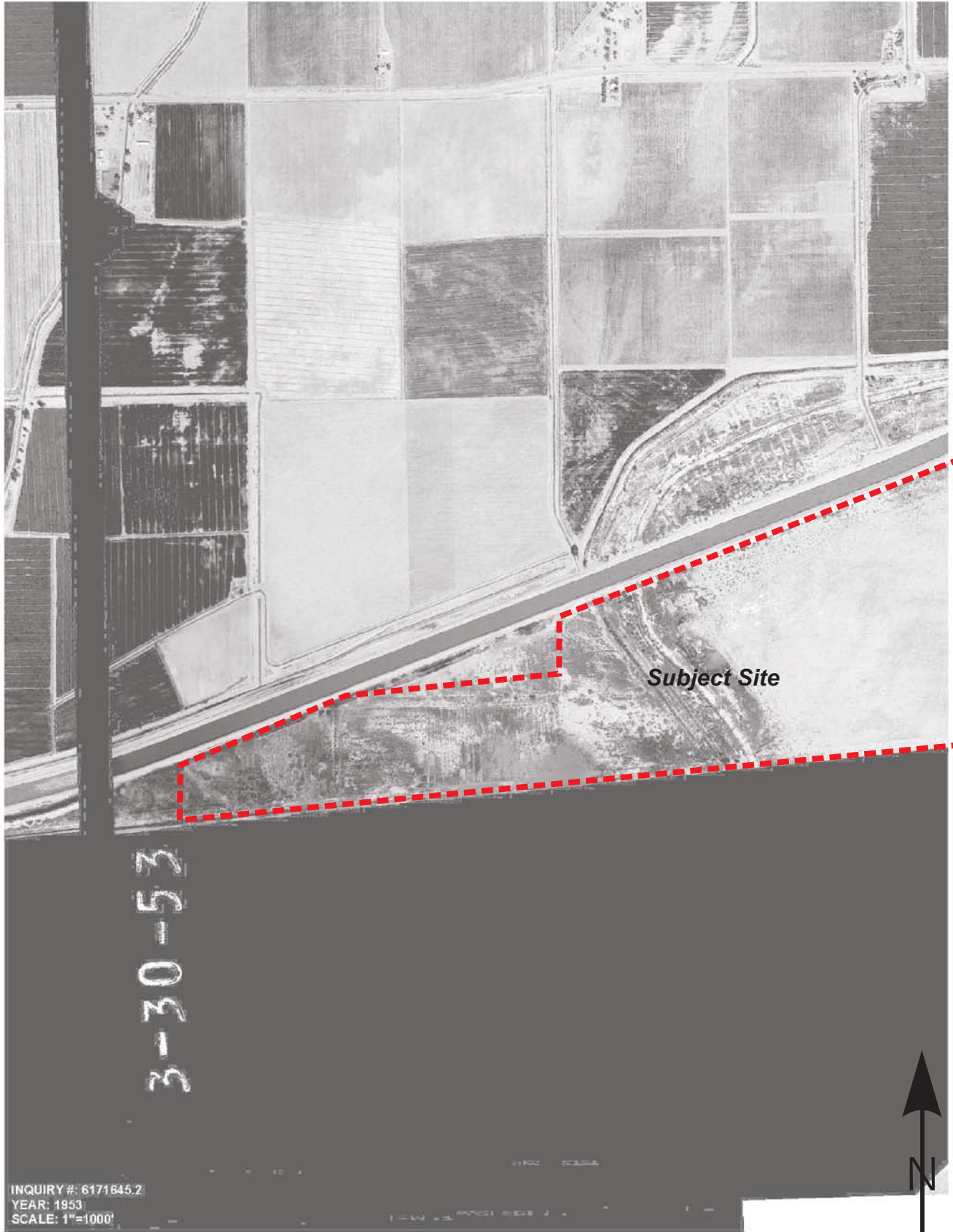
GS Lyon

Project No.: GS2015

1937 Aerial Photograph

Plate
5b

PC ORIGINAL PKG



3-30-53

Subject Site

INQUIRY #: 6171645.2
YEAR: 1953
SCALE: 1"=1000'



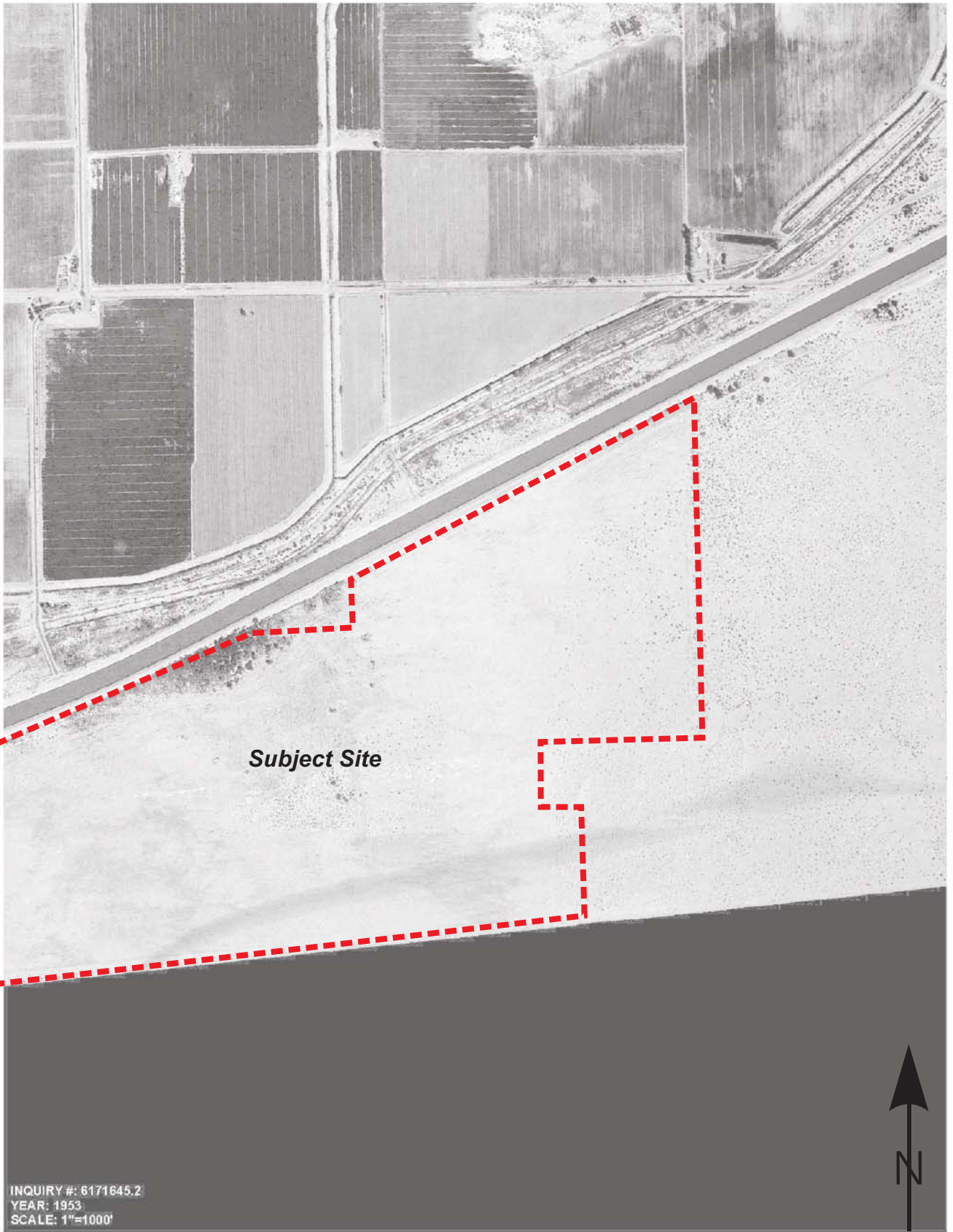
GS Lyon

Project No.: GS2015

1953 Aerial Photograph

Plate
6a

PC ORIGINAL PKG



INQUIRY #: 6171645.2
YEAR: 1953
SCALE: 1"=1000'

Subject Site



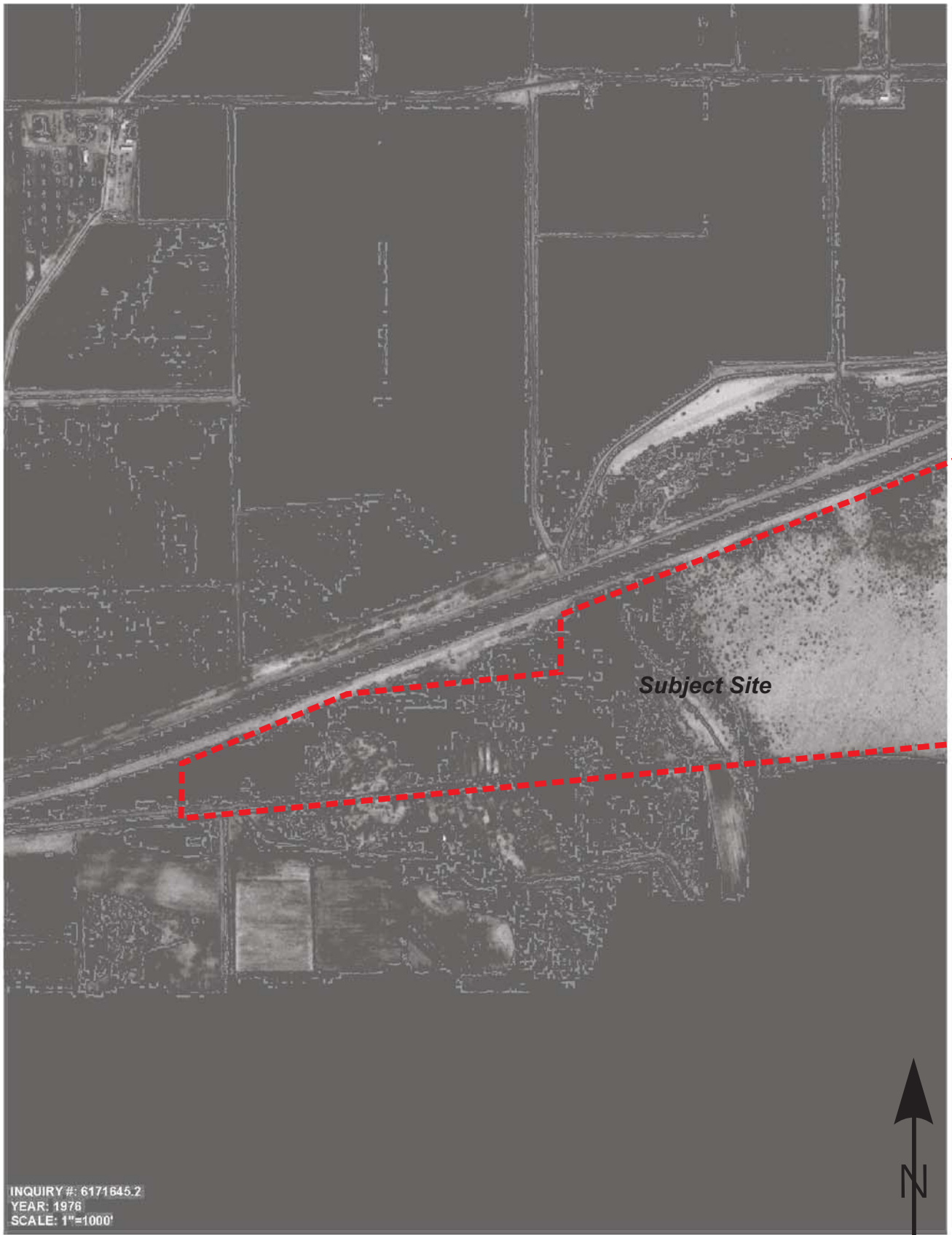
GS Lyon

Project No.: GS2015

1953 Aerial Photograph

Plate
6b

PC ORIGINAL PKG



INQUIRY #: 6171645.2
YEAR: 1976
SCALE: 1"=1000'

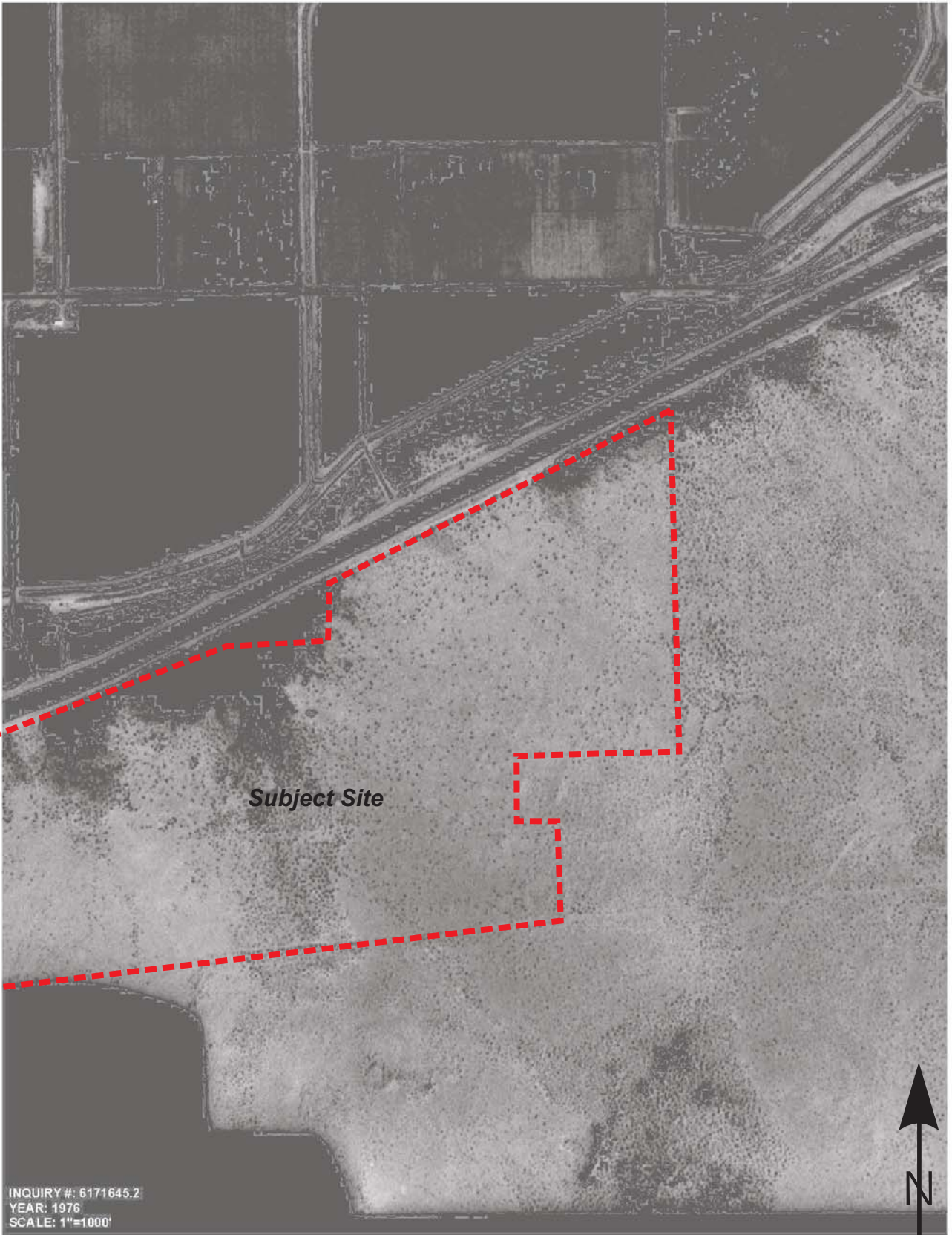
GS Lyon

Project No.: GS2015

1976 Aerial Photograph

Plate
7a

PC ORIGINAL PKG



INQUIRY #: 6171645.2
YEAR: 1976
SCALE: 1"=1000'



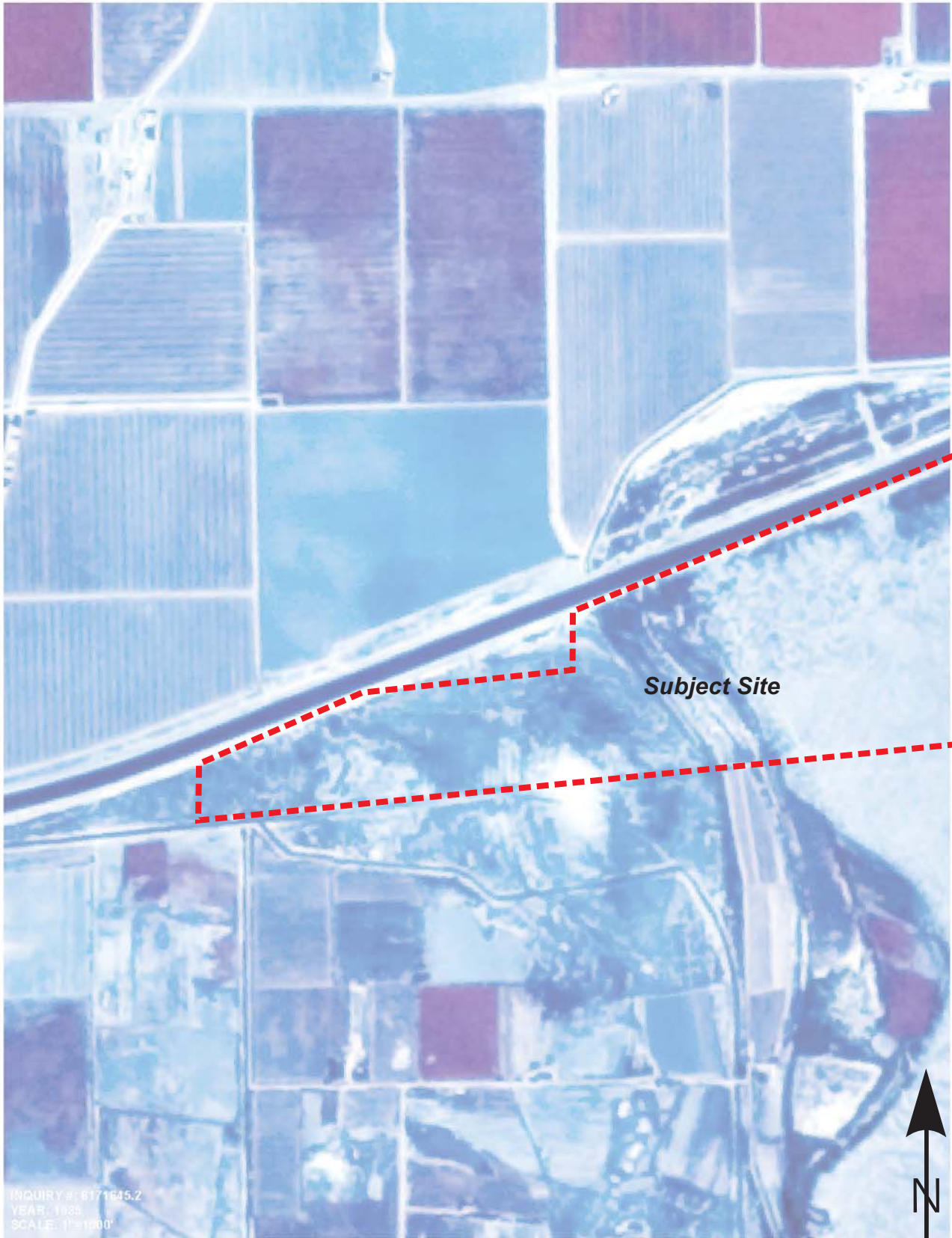
GS Lyon

Project No.: GS2015

1976 Aerial Photograph

Plate
7b

PC ORIGINAL PKG



INQUIRY #: 6171645.2
YEAR: 1985
SCALE: 1"=1000'



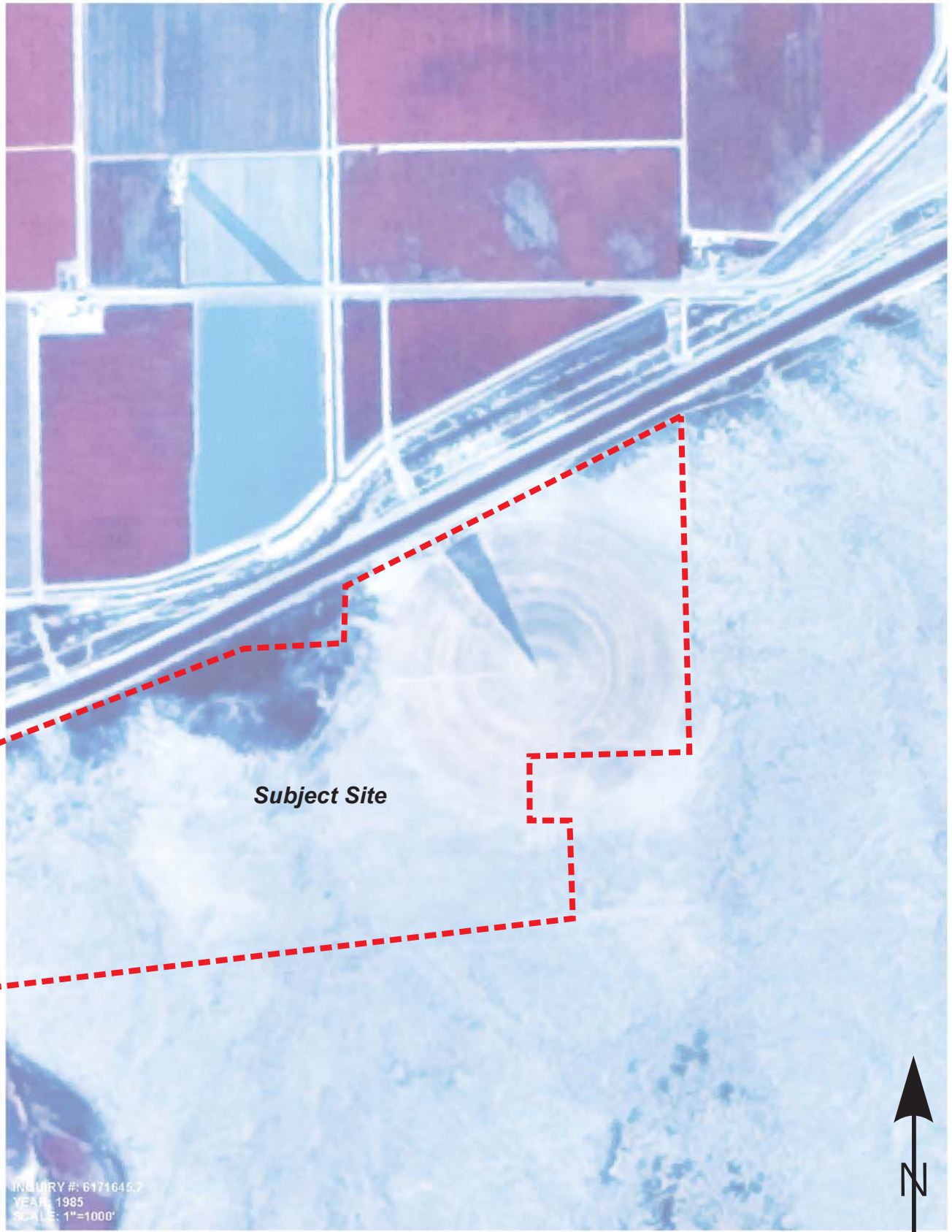
GS Lyon

Project No.: GS2015

1985 Aerial Photograph

Plate
8a

PC ORIGINAL PKG



INQUIRY #: 6171645.7
YEAR: 1985
SCALE: 1"=1000'

Subject Site



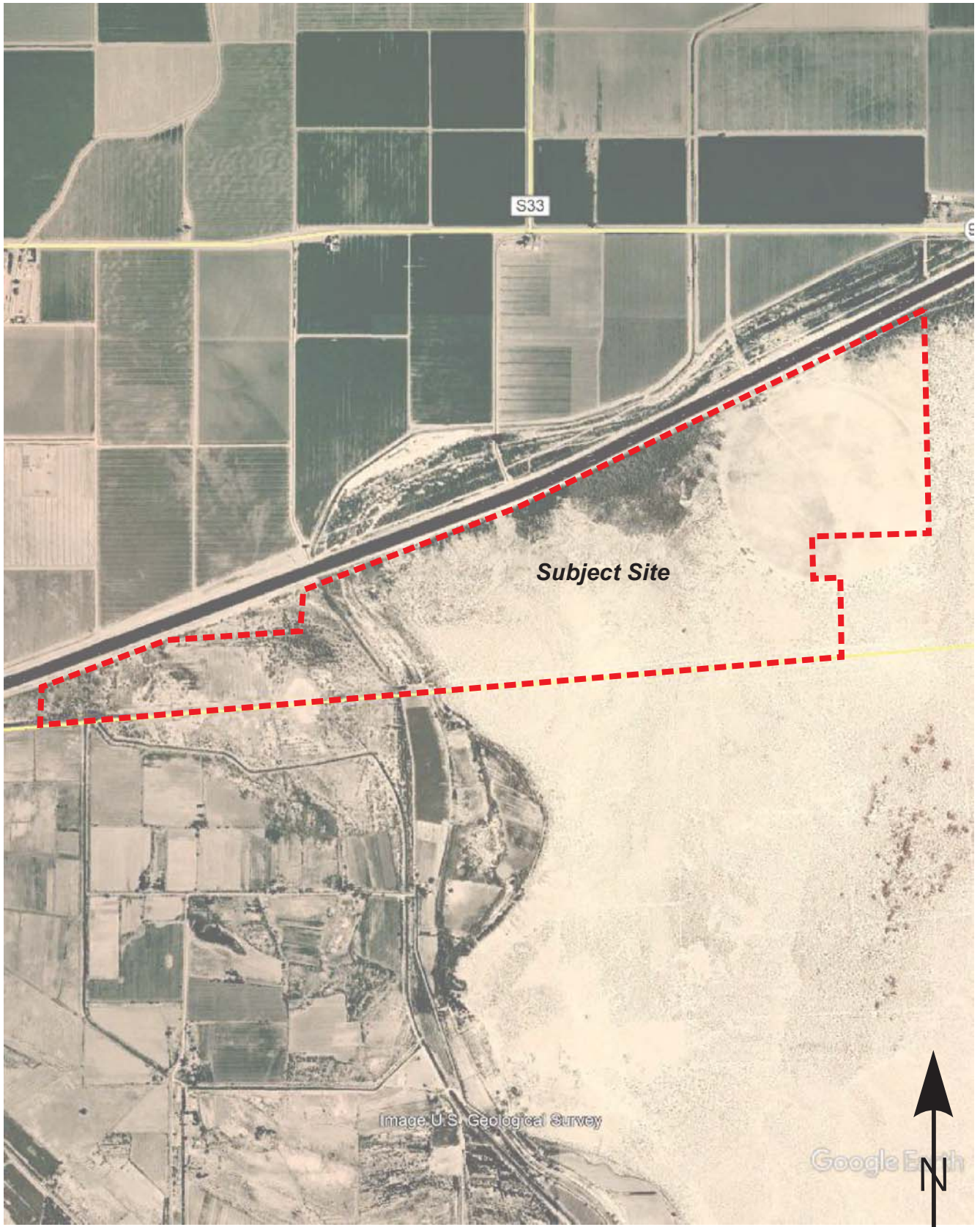
GS Lyon

Project No.: GS2015

1985 Aerial Photograph

Plate
8b

PC ORIGINAL PKG



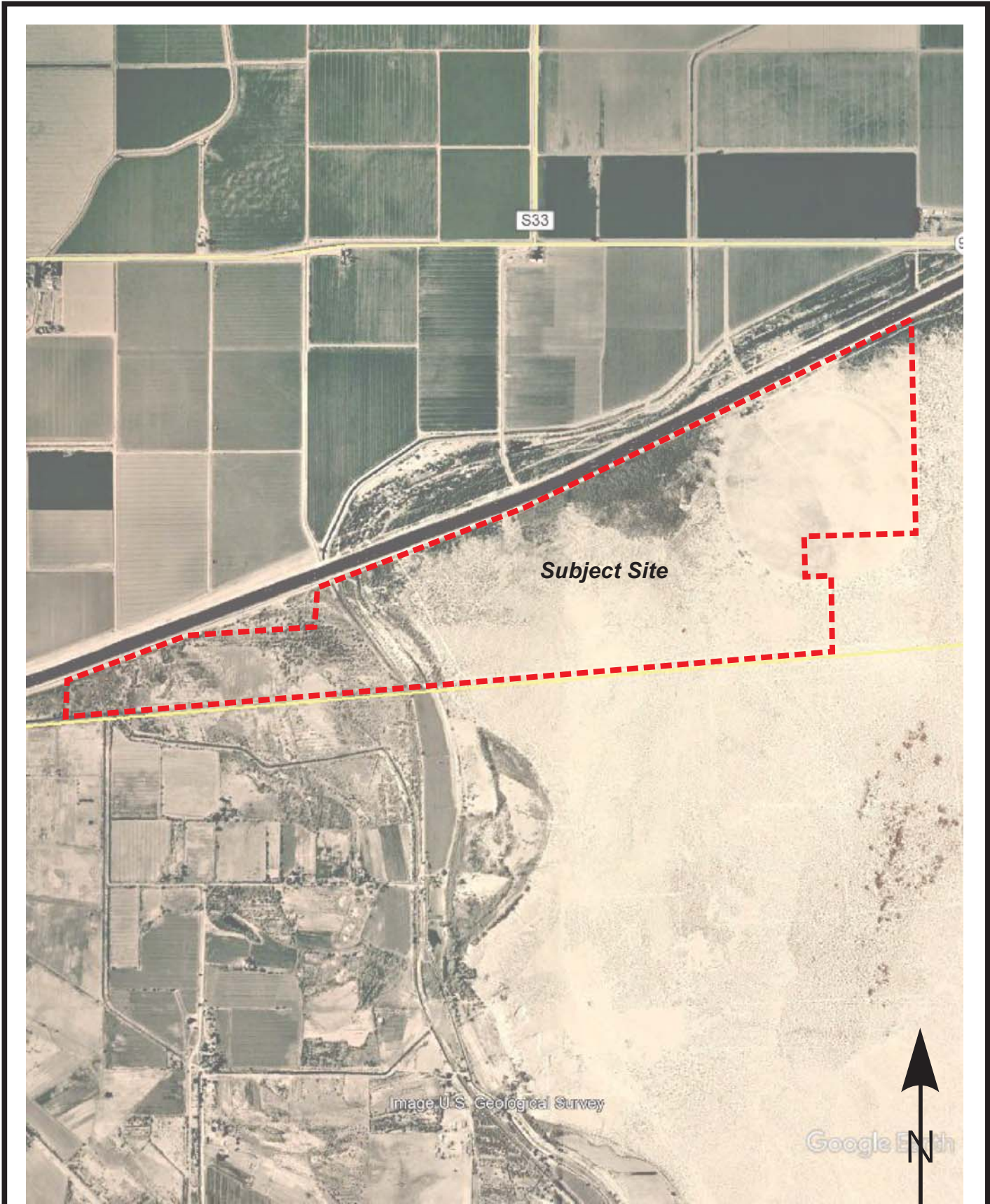
GS Lyon

Project No.: GS2015

1996 Aerial Photograph

Plate
9

PC ORIGINAL PKG



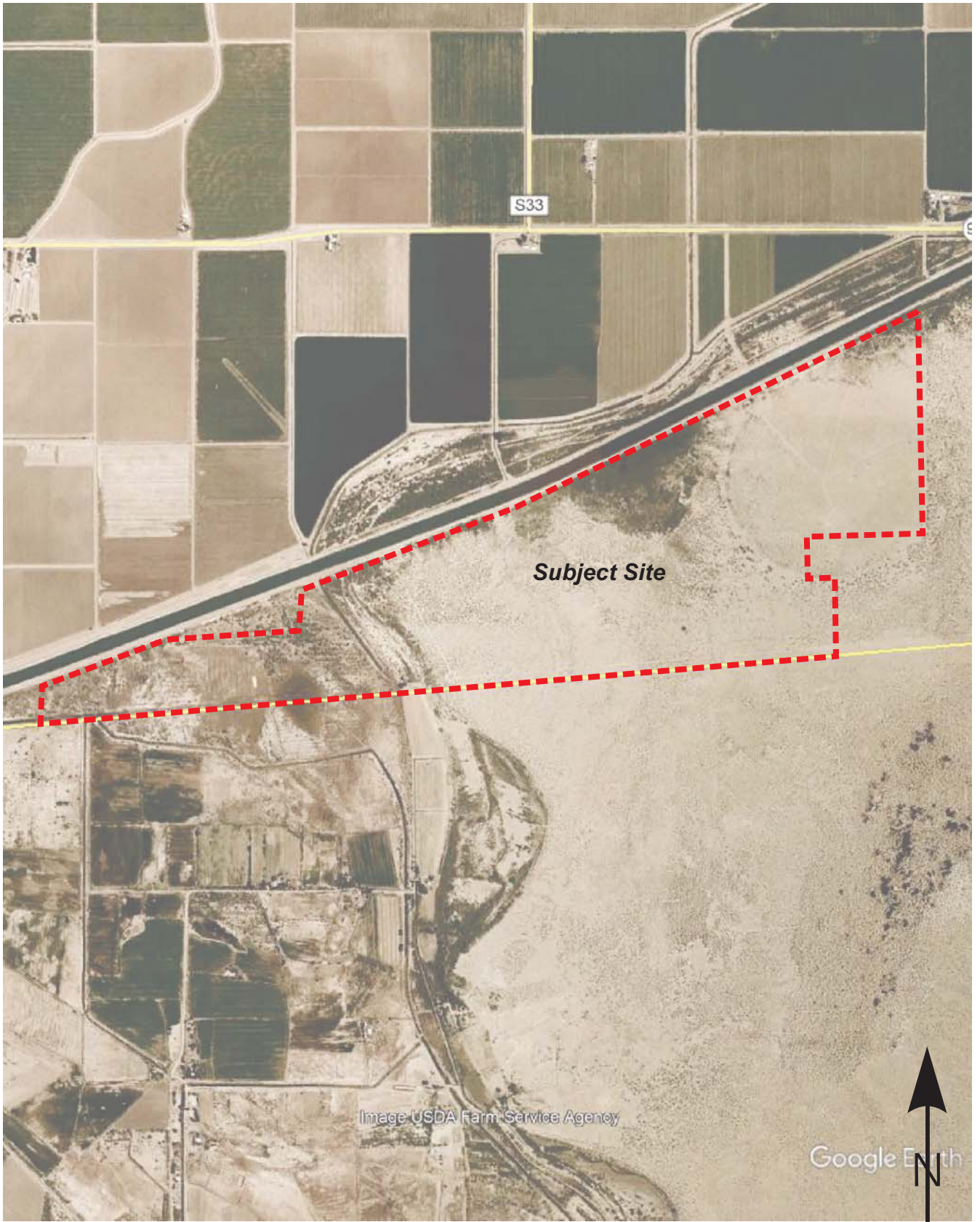
GS Lyon

Project No.: GS2015

2002 Aerial Photograph

Plate
10

PC ORIGINAL PKG



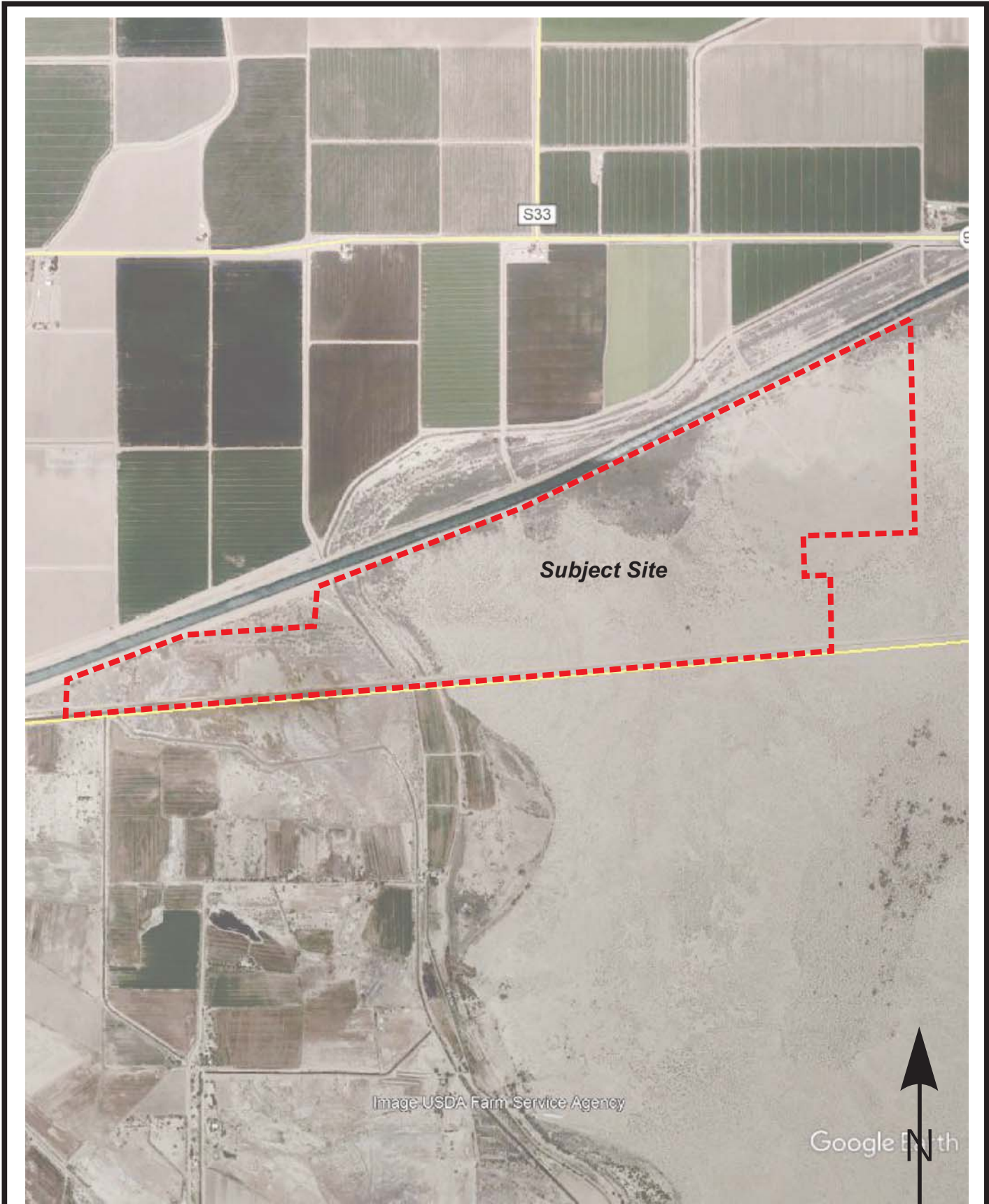
GS Lyon

Project No.: GS2015

2006 Aerial Photograph

Plate
11

PC ORIGINAL PKG



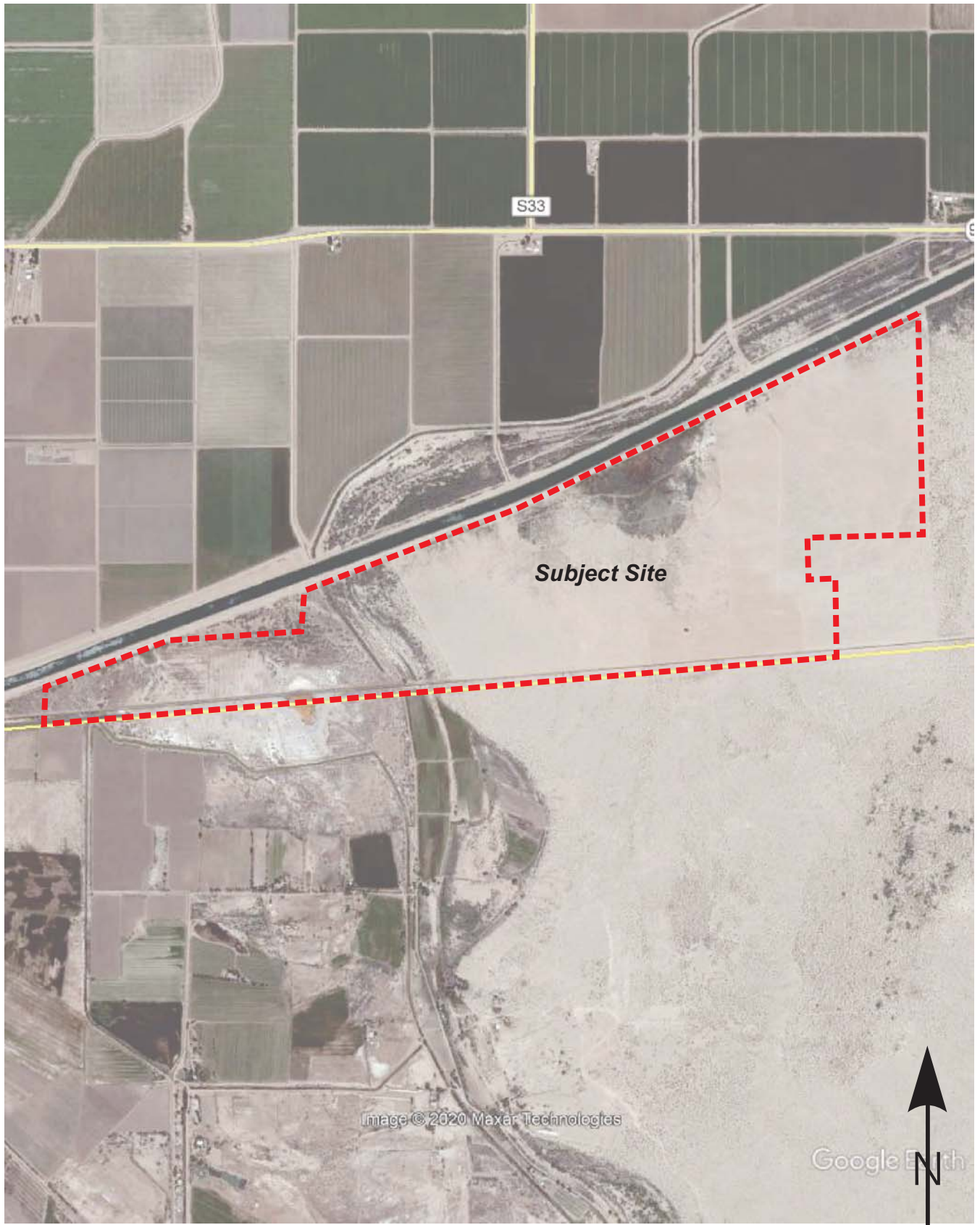
GS Lyon

Project No.: GS2015

2010 Aerial Photograph

Plate
12

PC ORIGINAL PKG



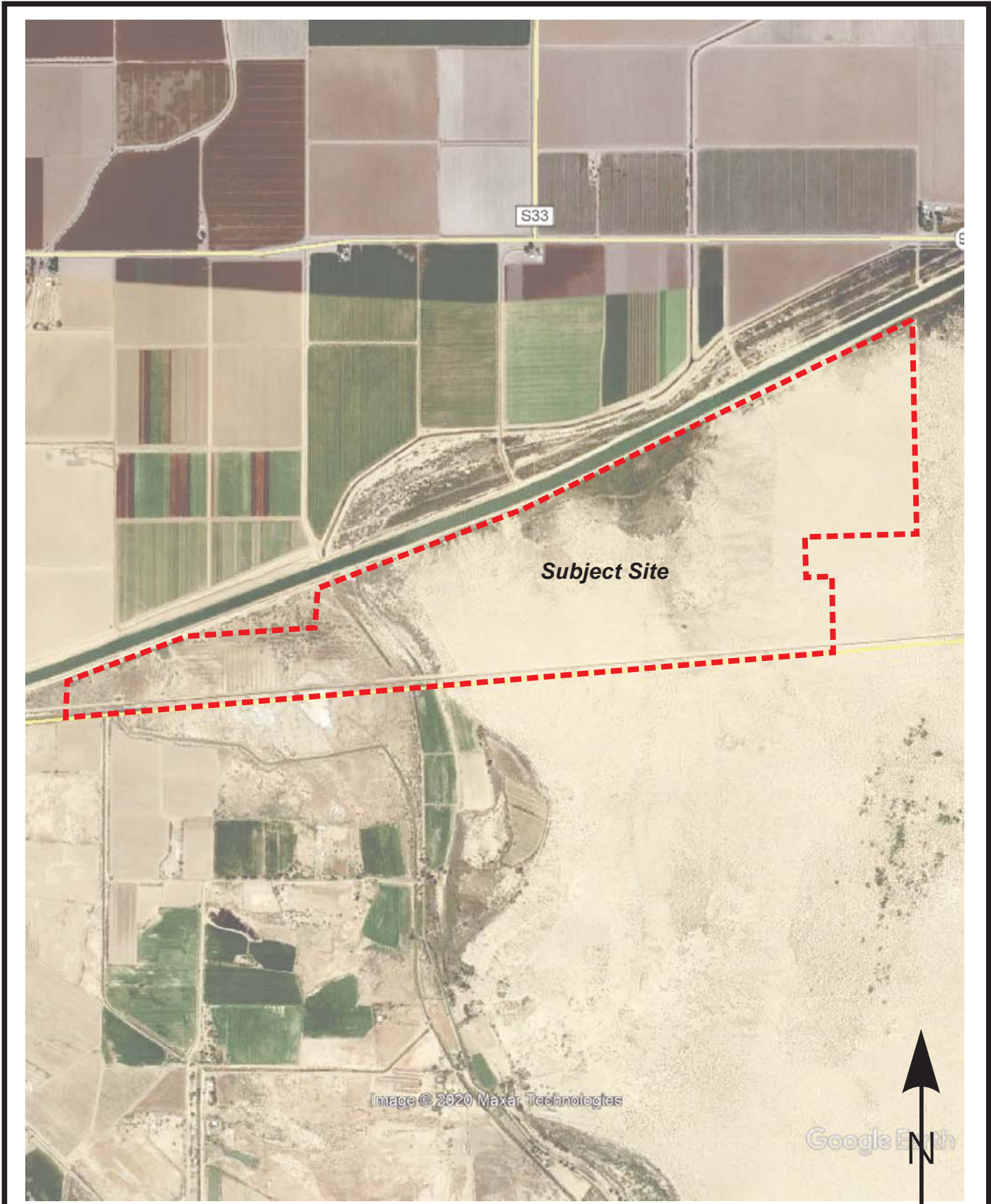
GS Lyon

Project No.: GS2015

2014 Aerial Photograph

Plate
13

PC ORIGINAL PKG



GS Lyon

Project No.: GS2015

2018 Aerial Photograph

Plate
14

PC ORIGINAL PKG

APPENDIX D

PC ORIGINAL PKG

Cedar Solar 1
SEC All American Canal & Bonds Corner
Calexico, CA 92283

Inquiry Number: 6171645.1

August 28, 2020

EDR Historical Topo Map Report

with QuadMatch™



6 Armstrong Road, 4th floor
Shelton, CT 06484
Toll Free: 800.352.0050
www.edrnet.com

PC ORIGINAL PKG

EDR Historical Topo Map Report

08/28/20

Site Name:

Cedar Solar 1
SEC All American Canal & Bor
Calexico, CA 92283
EDR Inquiry # 6171645.1

Client Name:

GS Lyon Consultants
780 N. Fourth Street
El Centro, CA 92243
Contact: Peter E. Labrucherie



EDR Topographic Map Library has been searched by EDR and maps covering the target property location as provided by GS Lyon Consultants were identified for the years listed below. EDR's Historical Topo Map Report is designed to assist professionals in evaluating potential liability on a target property resulting from past activities. EDR's Historical Topo Map Report includes a search of a collection of public and private color historical topographic maps, dating back to the late 1800s.

Search Results:

Coordinates:

P.O.#	NA	Latitude:	32.682206 32° 40' 56" North
Project:	GS2015	Longitude:	-115.308199 -115° 18' 30" West
		UTM Zone:	Zone 11 North
		UTM X Meters:	658614.82
		UTM Y Meters:	3617321.89
		Elevation:	46.00' above sea level

Maps Provided:

2012
1976
1957
1947
1940
1907

Disclaimer - Copyright and Trademark Notice

This Report contains certain information obtained from a variety of public and other sources reasonably available to Environmental Data Resources, Inc. It cannot be concluded from this Report that coverage information for the target and surrounding properties does not exist from other sources. NO WARRANTY EXPRESSED OR IMPLIED, IS MADE WHATSOEVER IN CONNECTION WITH THIS REPORT. ENVIRONMENTAL DATA RESOURCES, INC. SPECIFICALLY DISCLAIMS THE MAKING OF ANY SUCH WARRANTIES, INCLUDING WITHOUT LIMITATION, MERCHANTABILITY OR FITNESS FOR A PARTICULAR USE OR PURPOSE. ALL RISK IS ASSUMED BY THE USER. IN NO EVENT SHALL ENVIRONMENTAL DATA RESOURCES, INC. BE LIABLE TO ANYONE, WHETHER ARISING OUT OF ERRORS OR OMISSIONS, NEGLIGENCE, ACCIDENT OR ANY OTHER CAUSE, FOR ANY LOSS OF DAMAGE, INCLUDING, WITHOUT LIMITATION, SPECIAL, INCIDENTAL, CONSEQUENTIAL, OR EXEMPLARY DAMAGES. ANY LIABILITY ON THE PART OF ENVIRONMENTAL DATA RESOURCES, INC. IS STRICTLY LIMITED TO A REFUND OF THE AMOUNT PAID FOR THIS REPORT. Purchaser accepts this Report "AS IS". Any analyses, estimates, ratings, environmental risk levels or risk codes provided in this Report are provided for illustrative purposes only, and are not intended to provide, nor should they be interpreted as providing any facts regarding, or prediction or forecast of, any environmental risk for any property. Only a Phase I Environmental Site Assessment performed by an environmental professional can provide information regarding the environmental risk for any property. Additionally, the information provided in this Report is not to be construed as legal advice.

Copyright 2020 by Environmental Data Resources, Inc. All rights reserved. Reproduction in any media or format, in whole or in part, of any report or map of Environmental Data Resources, Inc., or its affiliates, is prohibited without prior written permission.

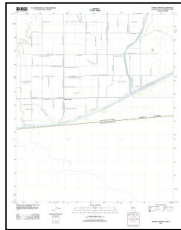
EDR and its logos (including Sanborn and Sanborn Map) are trademarks of Environmental Data Resources, Inc. or its affiliates. All other trademarks used herein are the property of their respective owners.

PC ORIGINAL PKG

Topo Sheet Key

This EDR Topo Map Report is based upon the following USGS topographic map sheets.

2012 Source Sheets



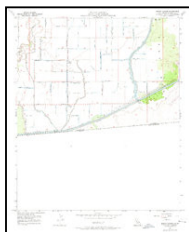
Bonds Corner
2012
7.5-minute, 24000

1976 Source Sheets



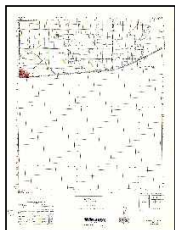
Bonds Corner
1976
7.5-minute, 24000
Aerial Photo Revised 1953

1957 Source Sheets



Bonds Corner
1957
7.5-minute, 24000
Aerial Photo Revised 1953

1947 Source Sheets



CALEXICO
1947
15-minute, 50000

Topo Sheet Key

This EDR Topo Map Report is based upon the following USGS topographic map sheets.

1940 Source Sheets

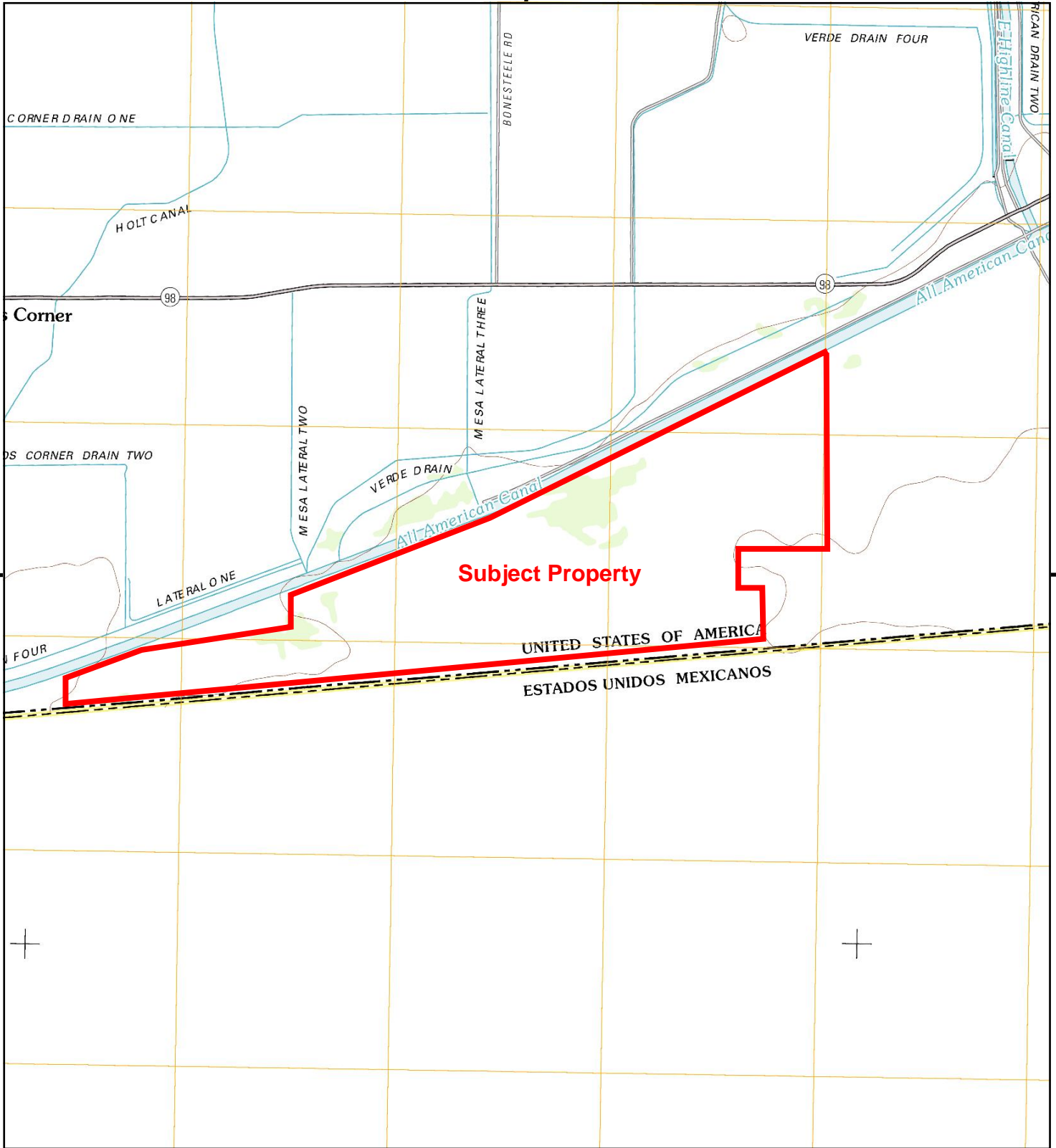


Calexico
1940
15-minute, 62500
Aerial Photo Revised 1940

1907 Source Sheets



Holtville
1907
30-minute, 125000



This report includes information from the following map sheet(s).

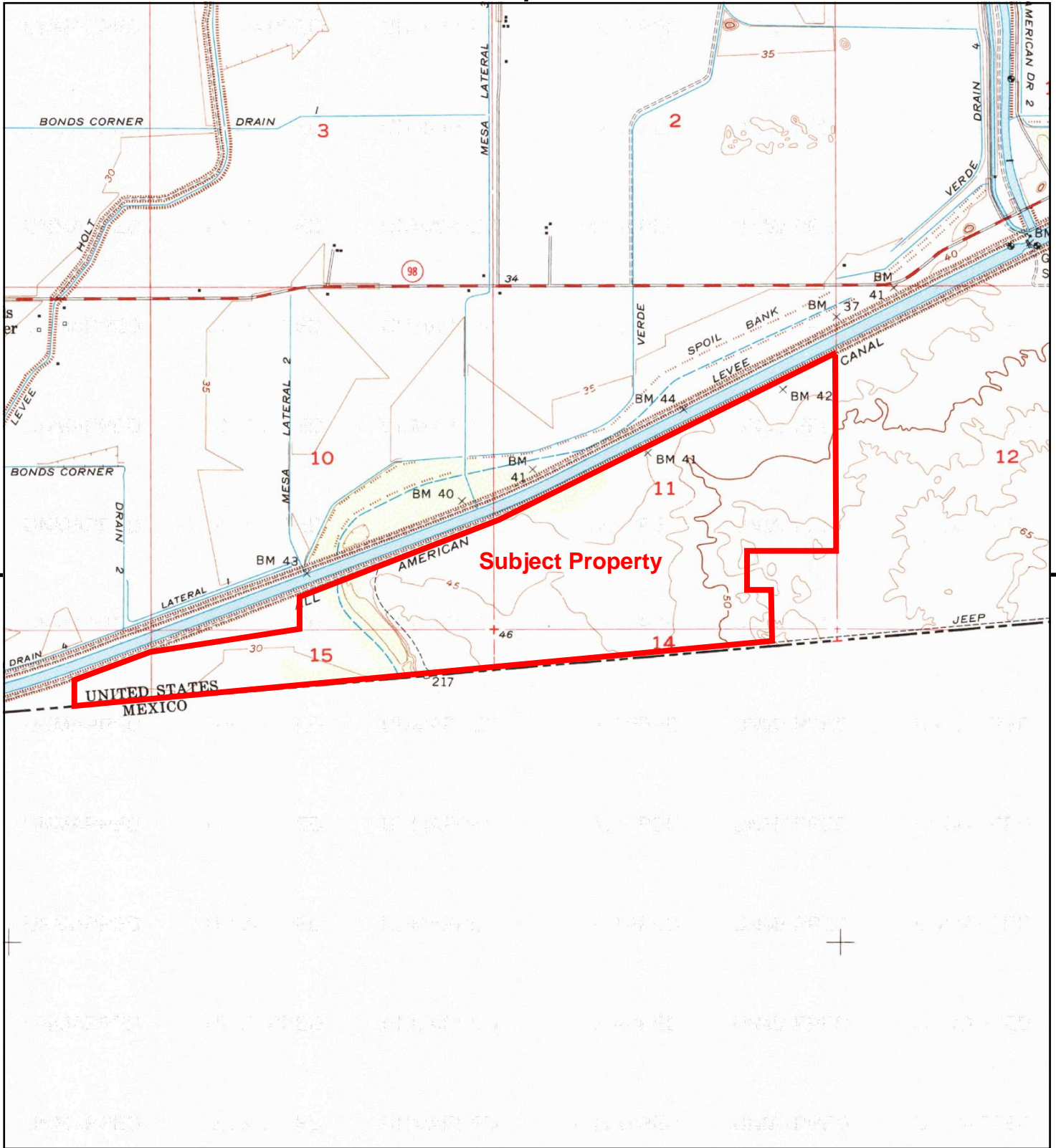


TP, Bonds Corner, 2012, 7.5-minute

SITE NAME: Cedar Solar 1
 ADDRESS: SEC All American Canal & Bonds Corner
 Calexico, CA 92283
 CLIENT: GS Lyon Consultants



PC ORIGINAL PKG



This report includes information from the following map sheet(s).

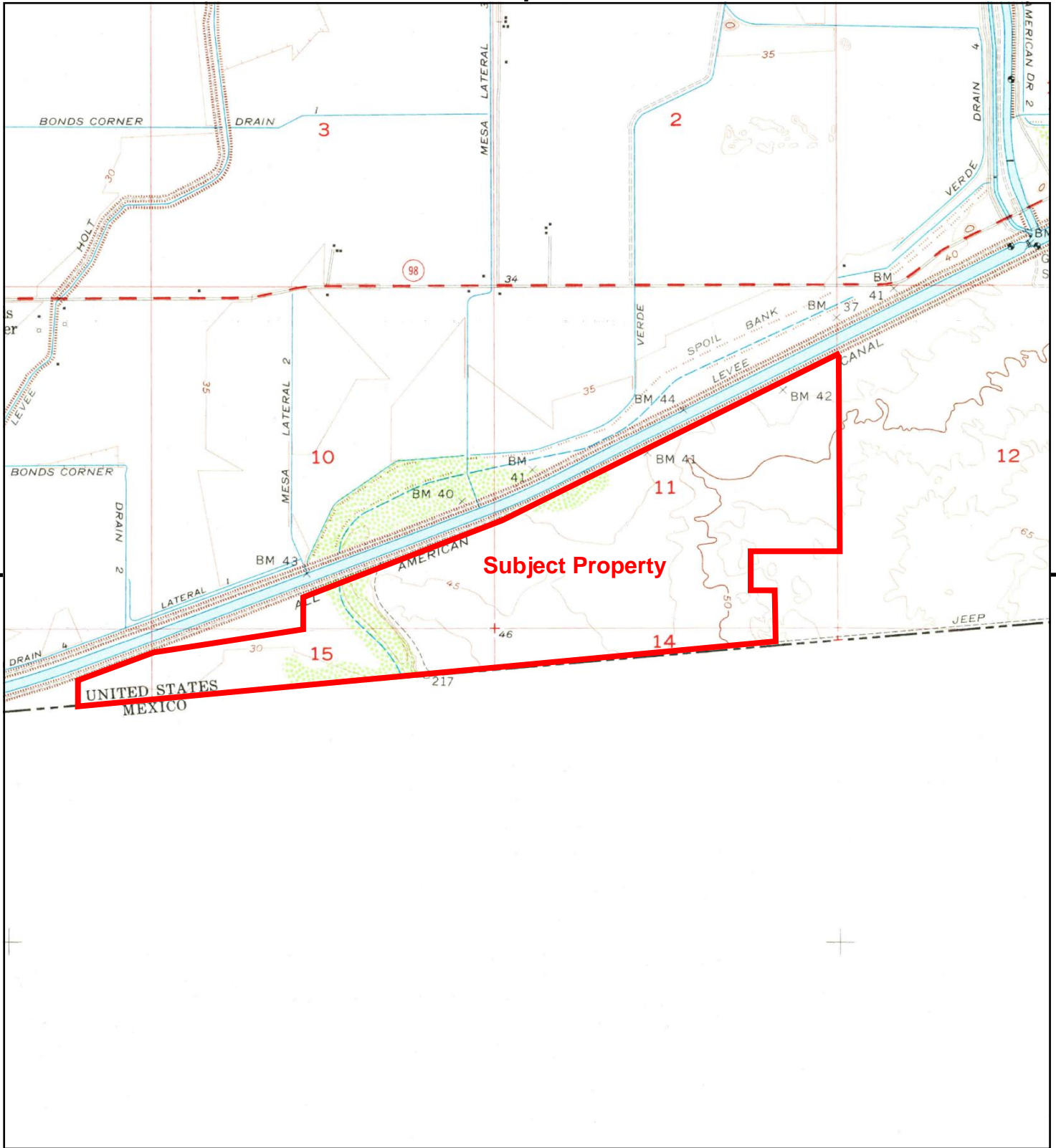


TP, Bonds Corner, 1976, 7.5-minute

SITE NAME: Cedar Solar 1
 ADDRESS: SEC All American Canal & Bonds Corner
 Calexico, CA 92283
 CLIENT: GS Lyon Consultants



PC ORIGINAL PKG



This report includes information from the following map sheet(s).

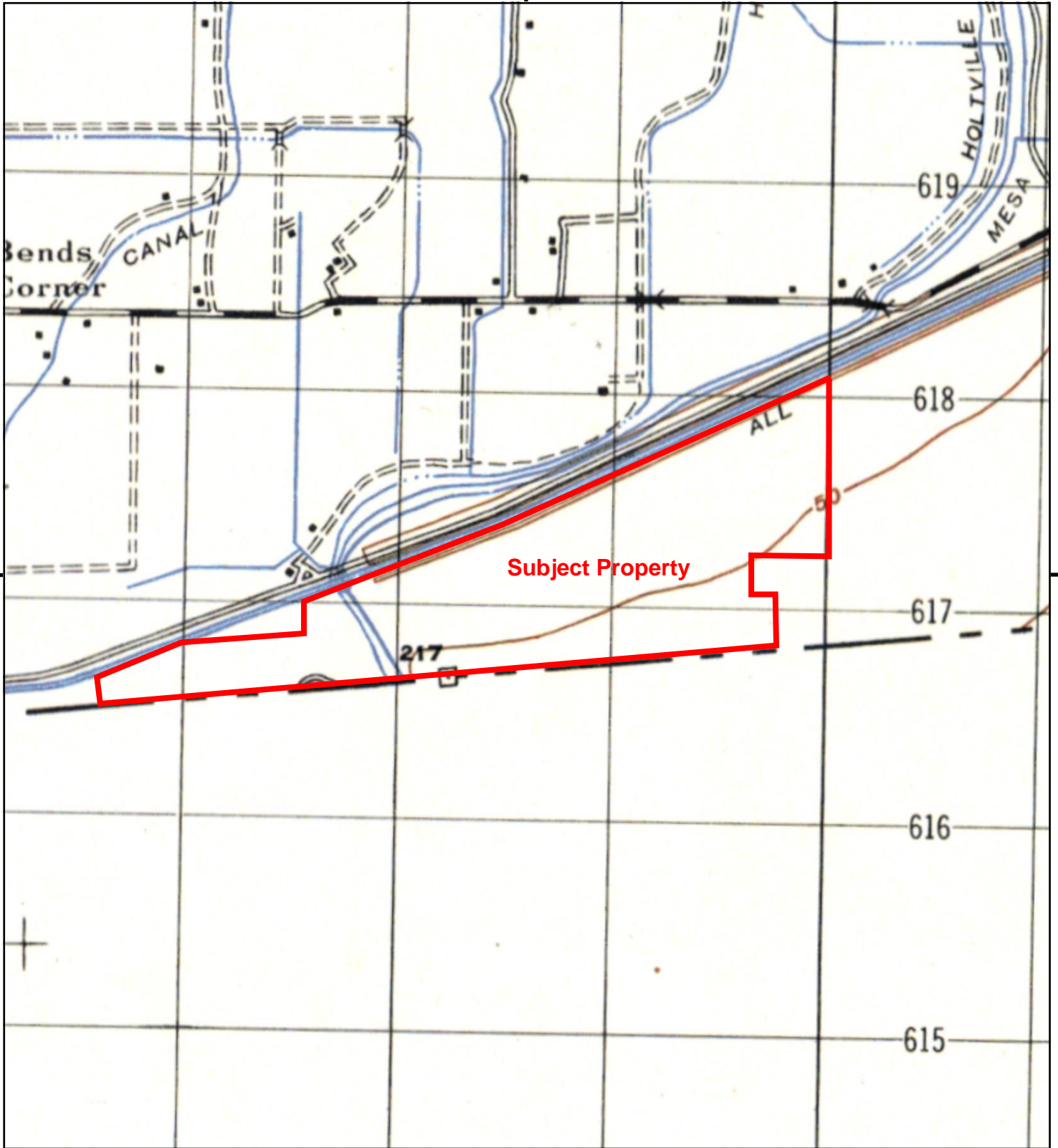


TP, Bonds Corner, 1957, 7.5-minute

SITE NAME: Cedar Solar 1
 ADDRESS: SEC All American Canal & Bonds Corner
 Calexico, CA 92283
 CLIENT: GS Lyon Consultants



PC ORIGINAL PKG



This report includes information from the following map sheet(s).

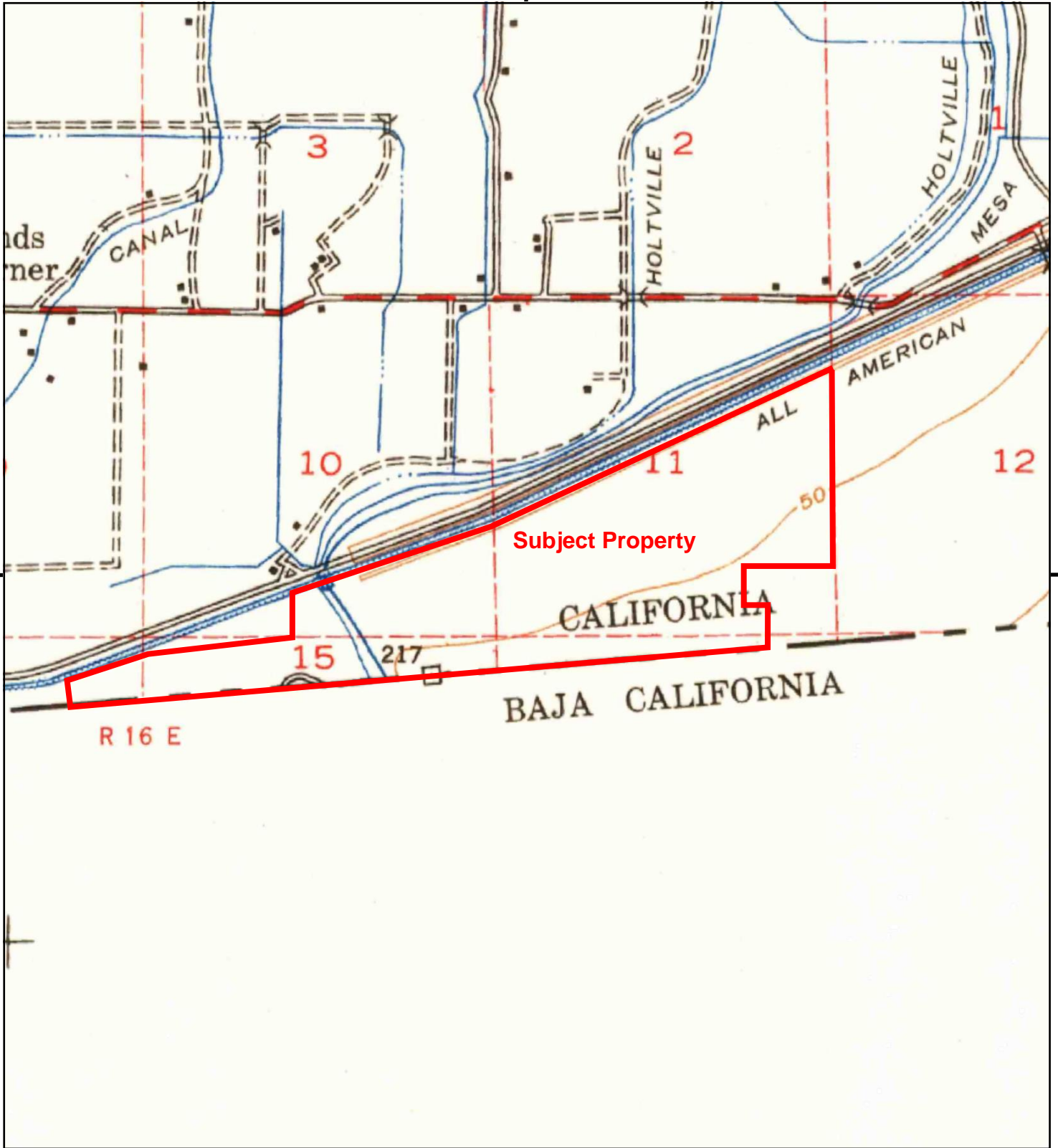


TP, CALEXICO, 1947, 15-minute

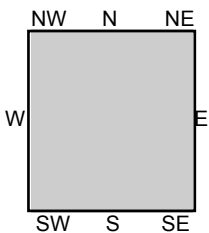
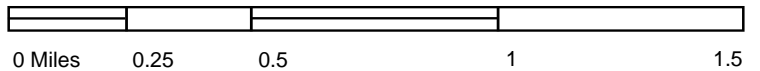
SITE NAME: Cedar Solar 1
 ADDRESS: SEC All American Canal & Bonds Corner
 Calexico, CA 92283
 CLIENT: GS Lyon Consultants



PC ORIGINAL PKG



This report includes information from the following map sheet(s).

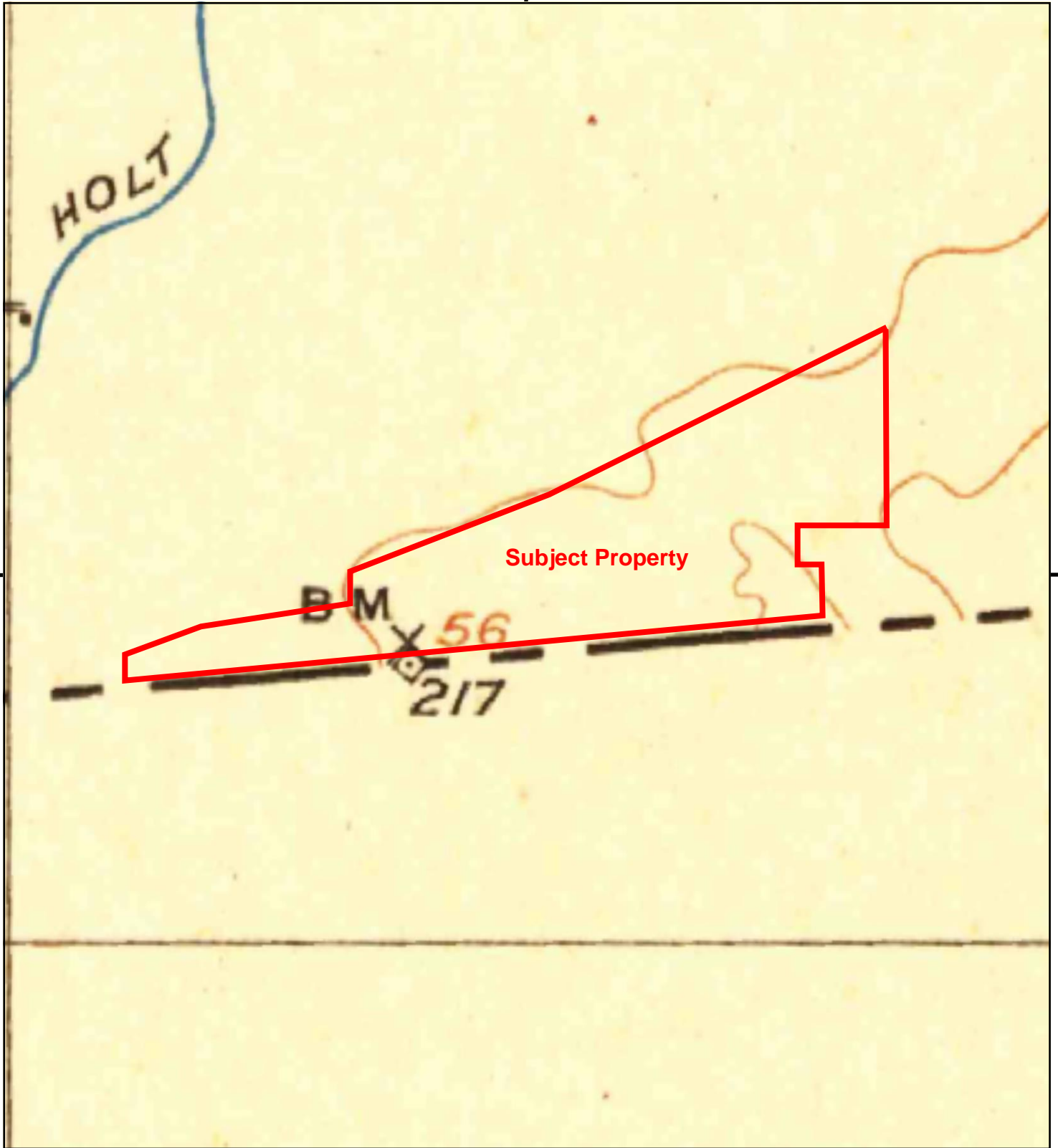


TP, Calexico, 1940, 15-minute

SITE NAME: Cedar Solar 1
 ADDRESS: SEC All American Canal & Bonds Corner
 Calexico, CA 92283
 CLIENT: GS Lyon Consultants



PC ORIGINAL PKG



This report includes information from the following map sheet(s).



TP, Holtville, 1907, 30-minute

SITE NAME: Cedar Solar 1
 ADDRESS: SEC All American Canal & Bonds Corner
 Calexico, CA 92283
 CLIENT: GS Lyon Consultants



PC ORIGINAL PKG

APPENDIX E

PC ORIGINAL PKG

Cedar Solar 1

SEC All American Canal & Bonds Corner
Calexico, CA 92283

Inquiry Number: 6171645.3s
August 27, 2020

EDR Area / Corridor Report



6 Armstrong Road, 4th floor
Shelton, CT 06484
Toll Free: 800.352.0050
www.edrnet.com

PC ORIGINAL PKG

TABLE OF CONTENTS

<u>SECTION</u>	<u>PAGE</u>
Executive Summary	ES1
Mapped Sites Summary	2
Key Map	2
Map Findings Summary	3
Focus Maps	8
Map Findings	20
Orphan Summary	OR-1
Government Records Searched/Data Currency Tracking	GR-1

Thank you for your business.
Please contact EDR at 1-800-352-0050
with any questions or comments.

Disclaimer - Copyright and Trademark Notice

This Report contains certain information obtained from a variety of public and other sources reasonably available to Environmental Data Resources, Inc. It cannot be concluded from this Report that coverage information for the target and surrounding properties does not exist from other sources. **NO WARRANTY EXPRESSED OR IMPLIED, IS MADE WHATSOEVER IN CONNECTION WITH THIS REPORT. ENVIRONMENTAL DATA RESOURCES, INC. SPECIFICALLY DISCLAIMS THE MAKING OF ANY SUCH WARRANTIES, INCLUDING WITHOUT LIMITATION, MERCHANTABILITY OR FITNESS FOR A PARTICULAR USE OR PURPOSE. ALL RISK IS ASSUMED BY THE USER. IN NO EVENT SHALL ENVIRONMENTAL DATA RESOURCES, INC. BE LIABLE TO ANYONE, WHETHER ARISING OUT OF ERRORS OR OMISSIONS, NEGLIGENCE, ACCIDENT OR ANY OTHER CAUSE, FOR ANY LOSS OF DAMAGE, INCLUDING, WITHOUT LIMITATION, SPECIAL, INCIDENTAL, CONSEQUENTIAL, OR EXEMPLARY DAMAGES. ANY LIABILITY ON THE PART OF ENVIRONMENTAL DATA RESOURCES, INC. IS STRICTLY LIMITED TO A REFUND OF THE AMOUNT PAID FOR THIS REPORT.** Purchaser accepts this Report "AS IS". Any analyses, estimates, ratings, environmental risk levels or risk codes provided in this Report are provided for illustrative purposes only, and are not intended to provide, nor should they be interpreted as providing any facts regarding, or prediction or forecast of, any environmental risk for any property. Only a Phase I Environmental Site Assessment performed by an environmental professional can provide information regarding the environmental risk for any property. Additionally, the information provided in this Report is not to be construed as legal advice.

Copyright 2020 by Environmental Data Resources, Inc. All rights reserved. Reproduction in any media or format, in whole or in part, of any report or map of Environmental Data Resources, Inc., or its affiliates, is prohibited without prior written permission.

EDR and its logos (including Sanborn and Sanborn Map) are trademarks of Environmental Data Resources, Inc. or its affiliates. All other trademarks used herein are the property of their respective owners.

EXECUTIVE SUMMARY

A search of available environmental records was conducted by Environmental Data Resources, Inc (EDR). The report was designed to assist parties seeking to meet the search requirements of EPA's Standards and Practices for All Appropriate Inquiries (40 CFR Part 312), the ASTM Standard Practice for Environmental Site Assessments (E 1527-13), the ASTM Standard Practice for Environmental Site Assessments for Forestland or Rural Property (E 2247-16), the ASTM Standard Practice for Limited Environmental Due Diligence: Transaction Screen Process (E 1528-14) or custom requirements developed for the evaluation of environmental risk associated with a parcel of real estate.

SUBJECT PROPERTY INFORMATION

ADDRESS

SEC ALL AMERICAN CANAL & BONDS CORNER
CALEXICO, CA 92283

TARGET PROPERTY SEARCH RESULTS

The Target Property was identified in the following databases.

Page Numbers and Map Identifications refer to the EDR Area/Corridor Report where detailed data on individual sites can be reviewed.

Sites listed in ***bold italics*** are in multiple databases.

SURROUNDING SITES: SEARCH RESULTS

Surrounding sites were not identified.

Unmappable (orphan) sites are not considered in the foregoing analysis.

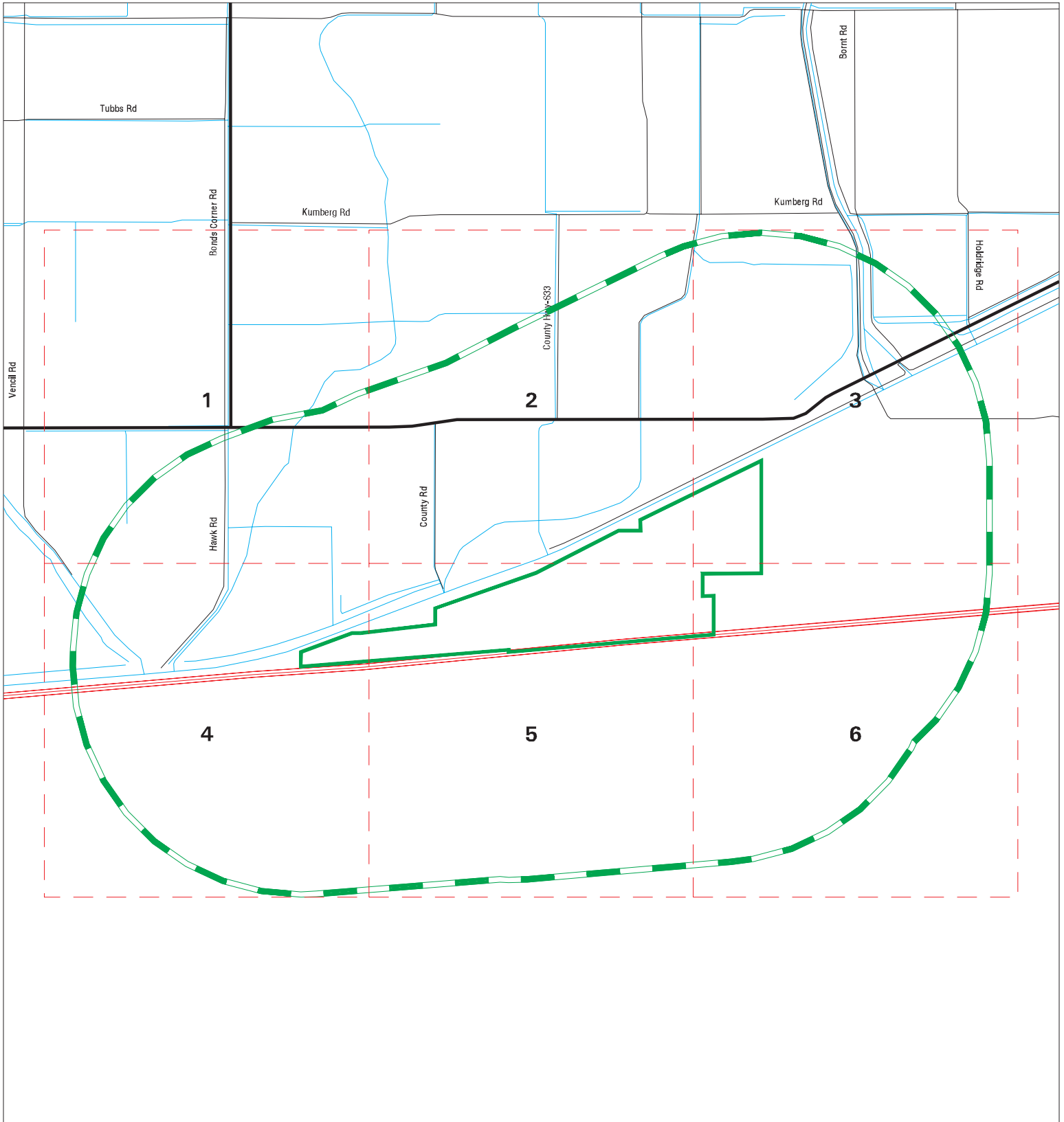
MAPPED SITES SUMMARY

Target Property:
SEC ALL AMERICAN CANAL & BONDS CORNER
CALEXICO, CA 92283

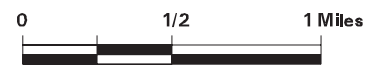
MAP ID / FOCUS MAP	SITE NAME	ADDRESS	DATABASE ACRONYMS	DIST (ft. & mi.) DIRECTION
-----------------------	-----------	---------	-------------------	-------------------------------

NO MAPPED SITES FOUND

Key Map - 6171645.3s



- ▲ Sites
- ▬ Target Property
- ▬ Search Buffer
- ▬ Focus Map - No Sites
- ▬ Focus Map - Sites
- National Priority List Sites
- Areas of Concern
- Dept. Defense Sites
- Indian Reservations BIA



SITE NAME: Cedar Solar 1 ADDRESS: SEC All American Canal & Bonds Corner CITY/STATE: Calexico CA ZIP: 92283	CLIENT: GS Lyon Consultants CONTACT: Peter E. Labrucherie INQUIRY #: 6171645.3s DATE: 09/27/20 4:51 PM
---------------------------------------------------------------------------------------------------------------------	----------------------------------------------------------------------------------------------------------------------

PC ORIGINAL PKG

MAP FINDINGS SUMMARY

Database	Search Distance (Miles)	Target Property	< 1/8	1/8 - 1/4	1/4 - 1/2	1/2 - 1	> 1	Total Plotted
<u>STANDARD ENVIRONMENTAL RECORDS</u>								
<i>Federal NPL site list</i>								
NPL	1.000		0	0	0	0	NR	0
Proposed NPL	1.000		0	0	0	0	NR	0
NPL LIENS	1.000		0	0	0	0	NR	0
<i>Federal Delisted NPL site list</i>								
Delisted NPL	1.000		0	0	0	0	NR	0
<i>Federal CERCLIS list</i>								
FEDERAL FACILITY	0.500		0	0	0	NR	NR	0
SEMS	0.500		0	0	0	NR	NR	0
<i>Federal CERCLIS NFRAP site list</i>								
SEMS-ARCHIVE	0.500		0	0	0	NR	NR	0
<i>Federal RCRA CORRACTS facilities list</i>								
CORRACTS	1.000		0	0	0	0	NR	0
<i>Federal RCRA non-CORRACTS TSD facilities list</i>								
RCRA-TSDF	0.500		0	0	0	NR	NR	0
<i>Federal RCRA generators list</i>								
RCRA-LQG	0.250		0	0	NR	NR	NR	0
RCRA-SQG	0.250		0	0	NR	NR	NR	0
RCRA-VSQG	0.250		0	0	NR	NR	NR	0
<i>Federal institutional controls / engineering controls registries</i>								
LUCIS	0.500		0	0	0	NR	NR	0
US ENG CONTROLS	0.500		0	0	0	NR	NR	0
US INST CONTROLS	0.500		0	0	0	NR	NR	0
<i>Federal ERNS list</i>								
ERNS	TP		NR	NR	NR	NR	NR	0
<i>State- and tribal - equivalent NPL RESPONSE</i>								
RESPONSE	1.000		0	0	0	0	NR	0
<i>State- and tribal - equivalent CERCLIS ENVIROSTOR</i>								
ENVIROSTOR	1.000		0	0	0	0	NR	0
<i>State and tribal landfill and/or solid waste disposal site lists</i>								
SWF/LF	0.500		0	0	0	NR	NR	0
<i>State and tribal leaking storage tank lists</i>								
LUST	0.500		0	0	0	NR	NR	0

MAP FINDINGS SUMMARY

Database	Search Distance (Miles)	Target Property	< 1/8	1/8 - 1/4	1/4 - 1/2	1/2 - 1	> 1	Total Plotted
INDIAN LUST	0.500		0	0	0	NR	NR	0
CPS-SLIC	0.500		0	0	0	NR	NR	0
State and tribal registered storage tank lists								
FEMA UST	0.250		0	0	NR	NR	NR	0
UST	0.250		0	0	NR	NR	NR	0
AST	0.250		0	0	NR	NR	NR	0
INDIAN UST	0.250		0	0	NR	NR	NR	0
State and tribal voluntary cleanup sites								
VCP	0.500		0	0	0	NR	NR	0
INDIAN VCP	0.500		0	0	0	NR	NR	0
State and tribal Brownfields sites								
BROWNFIELDS	0.500		0	0	0	NR	NR	0
<u>ADDITIONAL ENVIRONMENTAL RECORDS</u>								
Local Brownfield lists								
US BROWNFIELDS	0.500		0	0	0	NR	NR	0
Local Lists of Landfill / Solid Waste Disposal Sites								
WMUDS/SWAT	0.500		0	0	0	NR	NR	0
SWRCY	0.500		0	0	0	NR	NR	0
HAULERS	TP		NR	NR	NR	NR	NR	0
INDIAN ODI	0.500		0	0	0	NR	NR	0
DEBRIS REGION 9	0.500		0	0	0	NR	NR	0
ODI	0.500		0	0	0	NR	NR	0
IHS OPEN DUMPS	0.500		0	0	0	NR	NR	0
Local Lists of Hazardous waste / Contaminated Sites								
US HIST CDL	TP		NR	NR	NR	NR	NR	0
HIST Cal-Sites	1.000		0	0	0	0	NR	0
SCH	0.250		0	0	NR	NR	NR	0
CDL	TP		NR	NR	NR	NR	NR	0
Toxic Pits	1.000		0	0	0	0	NR	0
CERS HAZ WASTE	0.250		0	0	NR	NR	NR	0
US CDL	TP		NR	NR	NR	NR	NR	0
PFAS	0.500		0	0	0	NR	NR	0
Local Lists of Registered Storage Tanks								
SWEEPS UST	0.250		0	0	NR	NR	NR	0
HIST UST	0.250		0	0	NR	NR	NR	0
CERS TANKS	0.250		0	0	NR	NR	NR	0
CA FID UST	0.250		0	0	NR	NR	NR	0
Local Land Records								
LIENS	TP		NR	NR	NR	NR	NR	0

MAP FINDINGS SUMMARY

Database	Search Distance (Miles)	Target Property	< 1/8	1/8 - 1/4	1/4 - 1/2	1/2 - 1	> 1	Total Plotted
LIENS 2	TP		NR	NR	NR	NR	NR	0
DEED	0.500		0	0	0	NR	NR	0
Records of Emergency Release Reports								
HMIRS	TP		NR	NR	NR	NR	NR	0
CHMIRS	TP		NR	NR	NR	NR	NR	0
LDS	TP		NR	NR	NR	NR	NR	0
MCS	TP		NR	NR	NR	NR	NR	0
SPILLS 90	TP		NR	NR	NR	NR	NR	0
Other Ascertainable Records								
RCRA NonGen / NLR	0.250		0	0	NR	NR	NR	0
FUDS	1.000		0	0	0	0	NR	0
DOD	1.000		0	0	0	0	NR	0
SCRD DRYCLEANERS	0.500		0	0	0	NR	NR	0
US FIN ASSUR	TP		NR	NR	NR	NR	NR	0
EPA WATCH LIST	TP		NR	NR	NR	NR	NR	0
2020 COR ACTION	0.250		0	0	NR	NR	NR	0
TSCA	TP		NR	NR	NR	NR	NR	0
TRIS	TP		NR	NR	NR	NR	NR	0
SSTS	TP		NR	NR	NR	NR	NR	0
ROD	1.000		0	0	0	0	NR	0
RMP	TP		NR	NR	NR	NR	NR	0
RAATS	TP		NR	NR	NR	NR	NR	0
PRP	TP		NR	NR	NR	NR	NR	0
PADS	TP		NR	NR	NR	NR	NR	0
ICIS	TP		NR	NR	NR	NR	NR	0
FTTS	TP		NR	NR	NR	NR	NR	0
MLTS	TP		NR	NR	NR	NR	NR	0
COAL ASH DOE	TP		NR	NR	NR	NR	NR	0
COAL ASH EPA	0.500		0	0	0	NR	NR	0
PCB TRANSFORMER	TP		NR	NR	NR	NR	NR	0
RADINFO	TP		NR	NR	NR	NR	NR	0
HIST FTTS	TP		NR	NR	NR	NR	NR	0
DOT OPS	TP		NR	NR	NR	NR	NR	0
CONSENT	1.000		0	0	0	0	NR	0
INDIAN RESERV	1.000		0	0	0	0	NR	0
FUSRAP	1.000		0	0	0	0	NR	0
UMTRA	0.500		0	0	0	NR	NR	0
LEAD SMELTERS	TP		NR	NR	NR	NR	NR	0
US AIRS	TP		NR	NR	NR	NR	NR	0
US MINES	0.250		0	0	NR	NR	NR	0
ABANDONED MINES	0.250		0	0	NR	NR	NR	0
FINDS	TP		NR	NR	NR	NR	NR	0
DOCKET HWC	TP		NR	NR	NR	NR	NR	0
ECHO	TP		NR	NR	NR	NR	NR	0
UXO	1.000		0	0	0	0	NR	0
FUELS PROGRAM	0.250		0	0	NR	NR	NR	0
CA BOND EXP. PLAN	1.000		0	0	0	0	NR	0
Cortese	0.500		0	0	0	NR	NR	0
CUPA Listings	0.250		0	0	NR	NR	NR	0

MAP FINDINGS SUMMARY

Database	Search Distance (Miles)	Target Property	< 1/8	1/8 - 1/4	1/4 - 1/2	1/2 - 1	> 1	Total Plotted
CUPA Listings	0.250		0	0	NR	NR	NR	0
DRYCLEANERS	0.250		0	0	NR	NR	NR	0
EMI	TP		NR	NR	NR	NR	NR	0
ENF	TP		NR	NR	NR	NR	NR	0
Financial Assurance	TP		NR	NR	NR	NR	NR	0
HAZNET	TP		NR	NR	NR	NR	NR	0
ICE	TP		NR	NR	NR	NR	NR	0
HIST CORTESE	0.500		0	0	0	NR	NR	0
HWP	1.000		0	0	0	0	NR	0
HWT	0.250		0	0	NR	NR	NR	0
MINES	0.250		0	0	NR	NR	NR	0
MWMP	0.250		0	0	NR	NR	NR	0
NPDES	TP		NR	NR	NR	NR	NR	0
PEST LIC	TP		NR	NR	NR	NR	NR	0
PROC	0.500		0	0	0	NR	NR	0
Notify 65	1.000		0	0	0	0	NR	0
UIC	TP		NR	NR	NR	NR	NR	0
UIC GEO	TP		NR	NR	NR	NR	NR	0
WASTEWATER PITS	0.500		0	0	0	NR	NR	0
WDS	TP		NR	NR	NR	NR	NR	0
WIP	0.250		0	0	NR	NR	NR	0
MILITARY PRIV SITES	TP		NR	NR	NR	NR	NR	0
PROJECT	TP		NR	NR	NR	NR	NR	0
WDR	TP		NR	NR	NR	NR	NR	0
CIWQS	TP		NR	NR	NR	NR	NR	0
CERS	TP		NR	NR	NR	NR	NR	0
NON-CASE INFO	TP		NR	NR	NR	NR	NR	0
OTHER OIL GAS	TP		NR	NR	NR	NR	NR	0
PROD WATER PONDS	TP		NR	NR	NR	NR	NR	0
SAMPLING POINT	TP		NR	NR	NR	NR	NR	0
WELL STIM PROJ	TP		NR	NR	NR	NR	NR	0
HWTS	TP		NR	NR	NR	NR	NR	0
MINES MRDS	TP		NR	NR	NR	NR	NR	0
<u>EDR HIGH RISK HISTORICAL RECORDS</u>								
<i>EDR Exclusive Records</i>								
EDR MGP	1.000		0	0	0	0	NR	0
EDR Hist Auto	0.125		0	NR	NR	NR	NR	0
EDR Hist Cleaner	0.125		0	NR	NR	NR	NR	0
<u>EDR RECOVERED GOVERNMENT ARCHIVES</u>								
<i>Exclusive Recovered Govt. Archives</i>								
RGA LF	TP		NR	NR	NR	NR	NR	0
RGA LUST	TP		NR	NR	NR	NR	NR	0
- Totals --		0	0	0	0	0	0	0

MAP FINDINGS SUMMARY

<u>Database</u>	<u>Search Distance (Miles)</u>	<u>Target Property</u>	<u>< 1/8</u>	<u>1/8 - 1/4</u>	<u>1/4 - 1/2</u>	<u>1/2 - 1</u>	<u>> 1</u>	<u>Total Plotted</u>
-----------------	----------------------------------------	----------------------------	-----------------	------------------	------------------	----------------	---------------	--------------------------

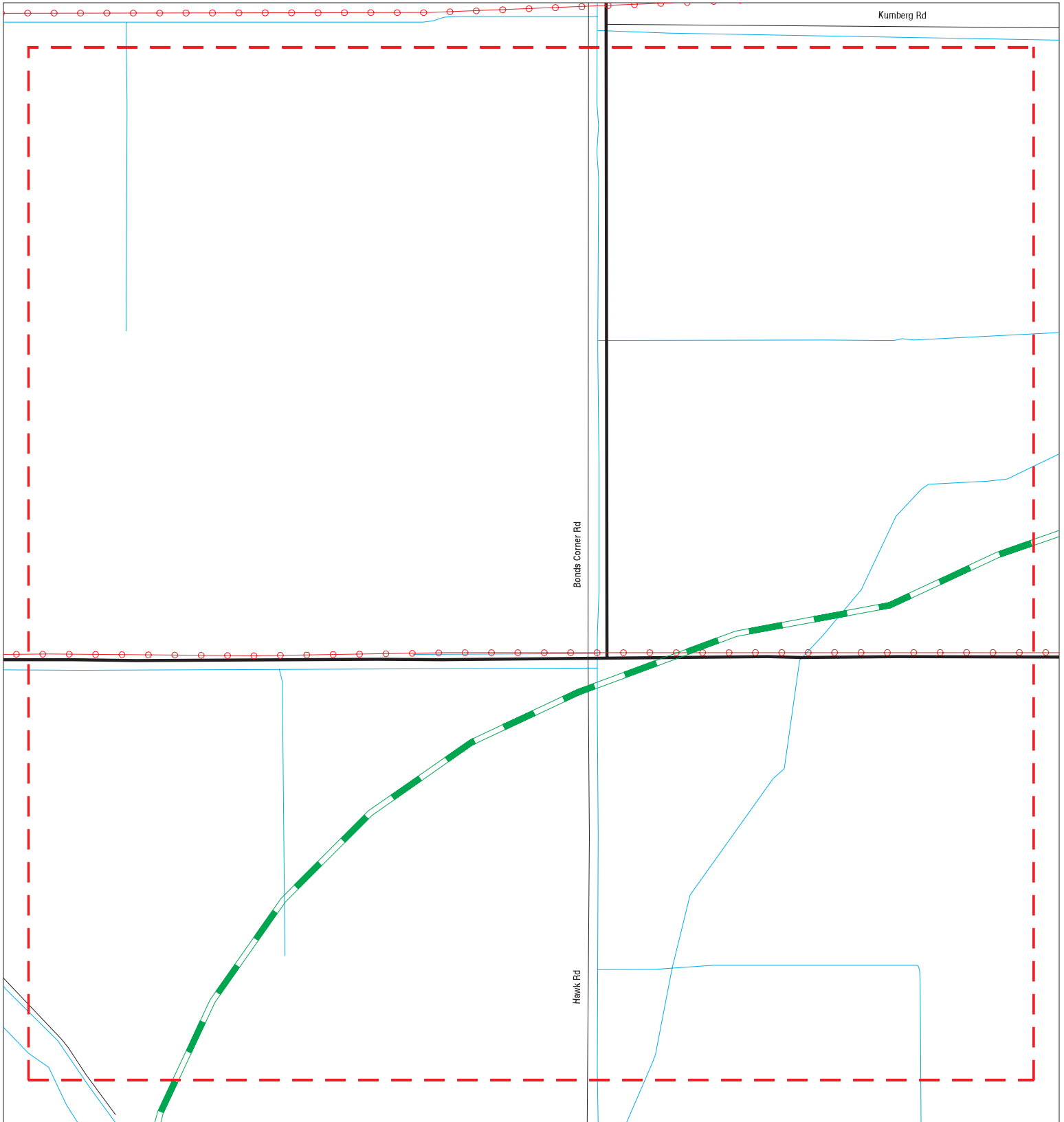
NOTES:












TP = Target Property

NR = Not Requested at this Search Distance

Sites may be listed in more than one database

Focus Map - 1 - 6171645.3s



- | | | | | | |
|------------------------------------------------------------------------------------|----------------------|-------------------------------------------------------------------------------------|------------------------------|-------------------------------------------------------------------------------------|-------------------------|
|  | Sites |  | Focus Map - Sites |  | Dept. Defense Sites |
|  | Target Property |  | Power Line |  | Indian Reservations BIA |
|  | Search Buffer |  | National Priority List Sites |  | Areas of Concern |
|  | Focus Map - No Sites |  | | | |



SITE NAME: Cedar Solar 1
ADDRESS: SEC All American Canal & Bonds Corner
CITY/STATE: Calexico CA
ZIP: 92283

CLIENT: GS Lyon Consultants
CONTACT: Peter E. Labrucherie
INQUIRY #: 6171645.3s
DATE: 09/27/20

PC ORIGINAL PKG

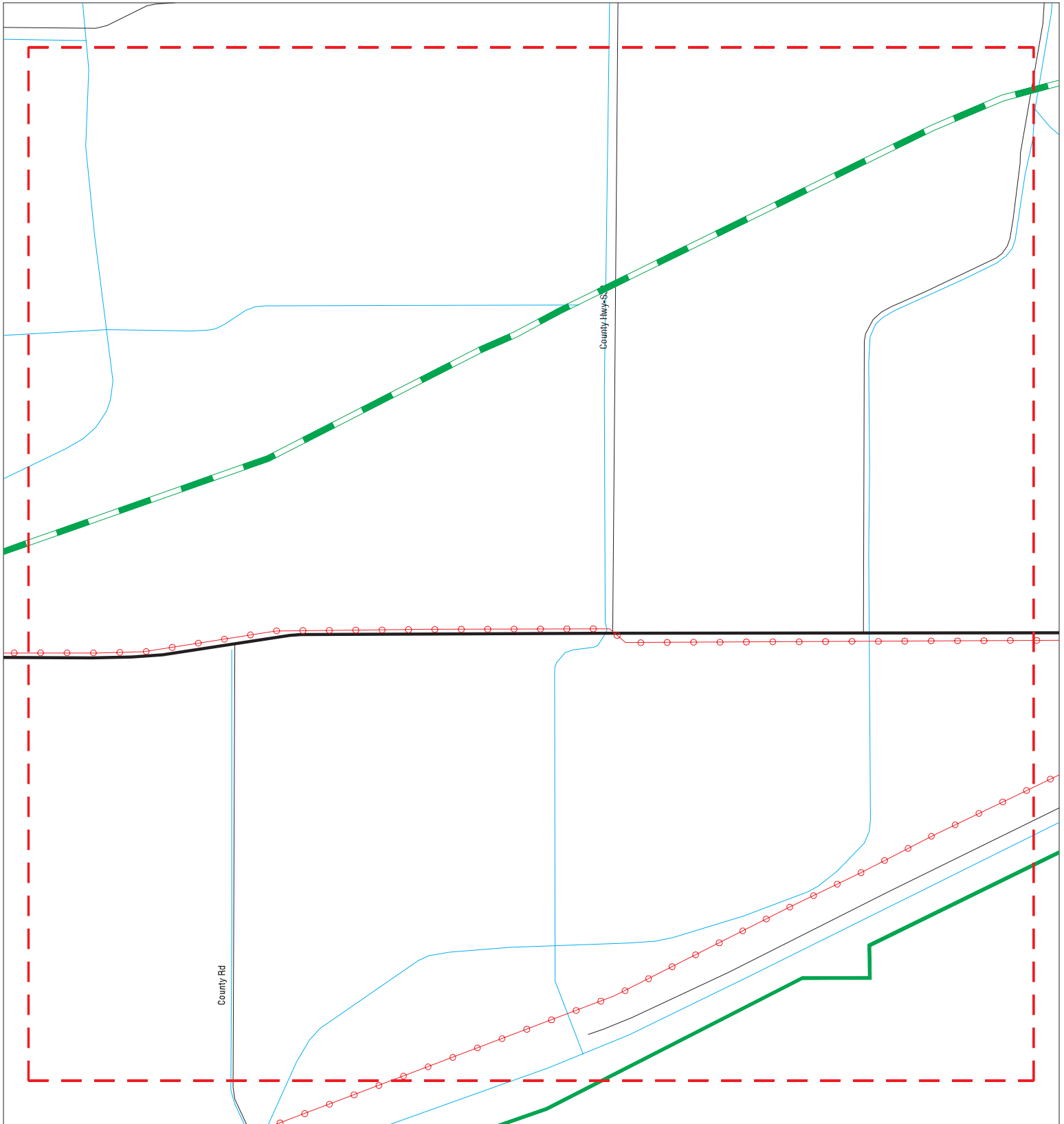
MAPPED SITES SUMMARY - FOCUS MAP 1











Target Property:
SEC ALL AMERICAN CANAL & BONDS CORNER
CALEXICO, CA 92283

MAP ID / FOCUS MAP	SITE NAME	ADDRESS	DATABASE ACRONYMS	DIST (ft. & mi.) DIRECTION
-----------------------	-----------	---------	-------------------	-------------------------------

NO MAPPED SITES FOUND

Focus Map - 2 - 6171645.3s



- | | | |
|---------------------------------------------------------------------------------------------------------|------------------------------------------------------------------------------------------------------------------|-------------------------------------------------------------------------------------------------------------|
|  Sites |  Focus Map - Sites |  Dept. Defense Sites |
|  Target Property |  Power Line |  Indian Reservations BIA |
|  Search Buffer |  National Priority List Sites |  Areas of Concern |
|  Focus Map - No Sites | | |



SITE NAME: Cedar Solar 1
ADDRESS: SEC All American Canal & Bonds Corner
CITY/STATE: Calexico CA
ZIP: 92283

CLIENT: GS Lyon Consultants
CONTACT: Peter E. Labrucherie
INQUIRY #: 6171645.3s
DATE: 09/27/20

PC ORIGINAL PKG

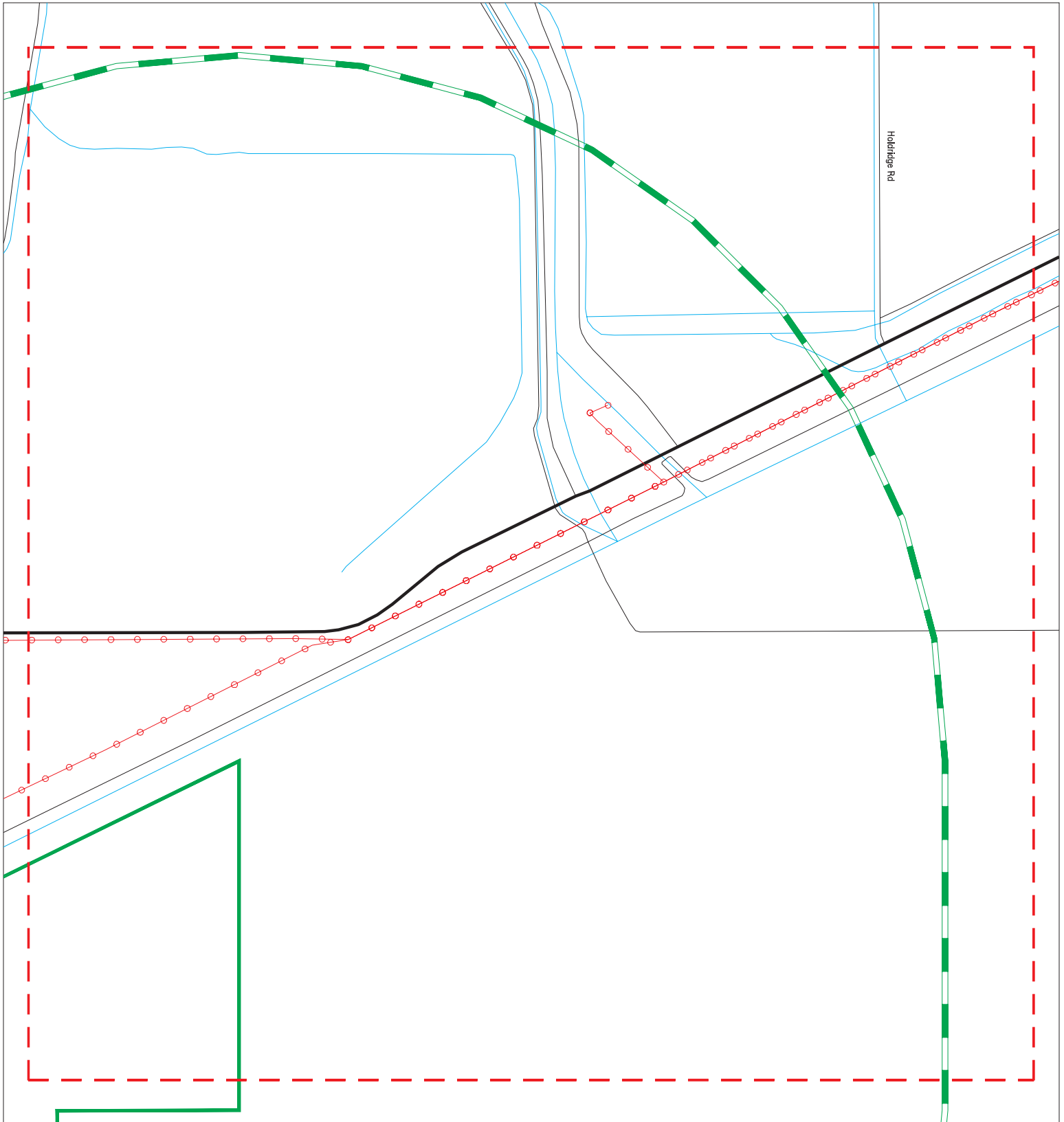
MAPPED SITES SUMMARY - FOCUS MAP 2











Target Property:
SEC ALL AMERICAN CANAL & BONDS CORNER
CALEXICO, CA 92283

MAP ID / FOCUS MAP	SITE NAME	ADDRESS	DATABASE ACRONYMS	DIST (ft. & mi.) DIRECTION
-----------------------	-----------	---------	-------------------	-------------------------------

NO MAPPED SITES FOUND

Focus Map - 3 - 6171645.3s



- | | | | | | |
|-----------------------------------------------------------------------------------|----------------------|-------------------------------------------------------------------------------------|------------------------------|-------------------------------------------------------------------------------------|-------------------------|
|  | Sites |  | Focus Map - Sites |  | Dept. Defense Sites |
|  | Target Property |  | Power Line |  | Indian Reservations BIA |
|  | Search Buffer |  | National Priority List Sites |  | Areas of Concern |
|  | Focus Map - No Sites | | | | |



SITE NAME: Cedar Solar 1
ADDRESS: SEC All American Canal & Bonds Corner
CITY/STATE: Calexico CA
ZIP: 92283

CLIENT: GS Lyon Consultants
CONTACT: Peter E. Labrucherie
INQUIRY #: 6171645.3s
DATE: 09/27/20

PC ORIGINAL PKG

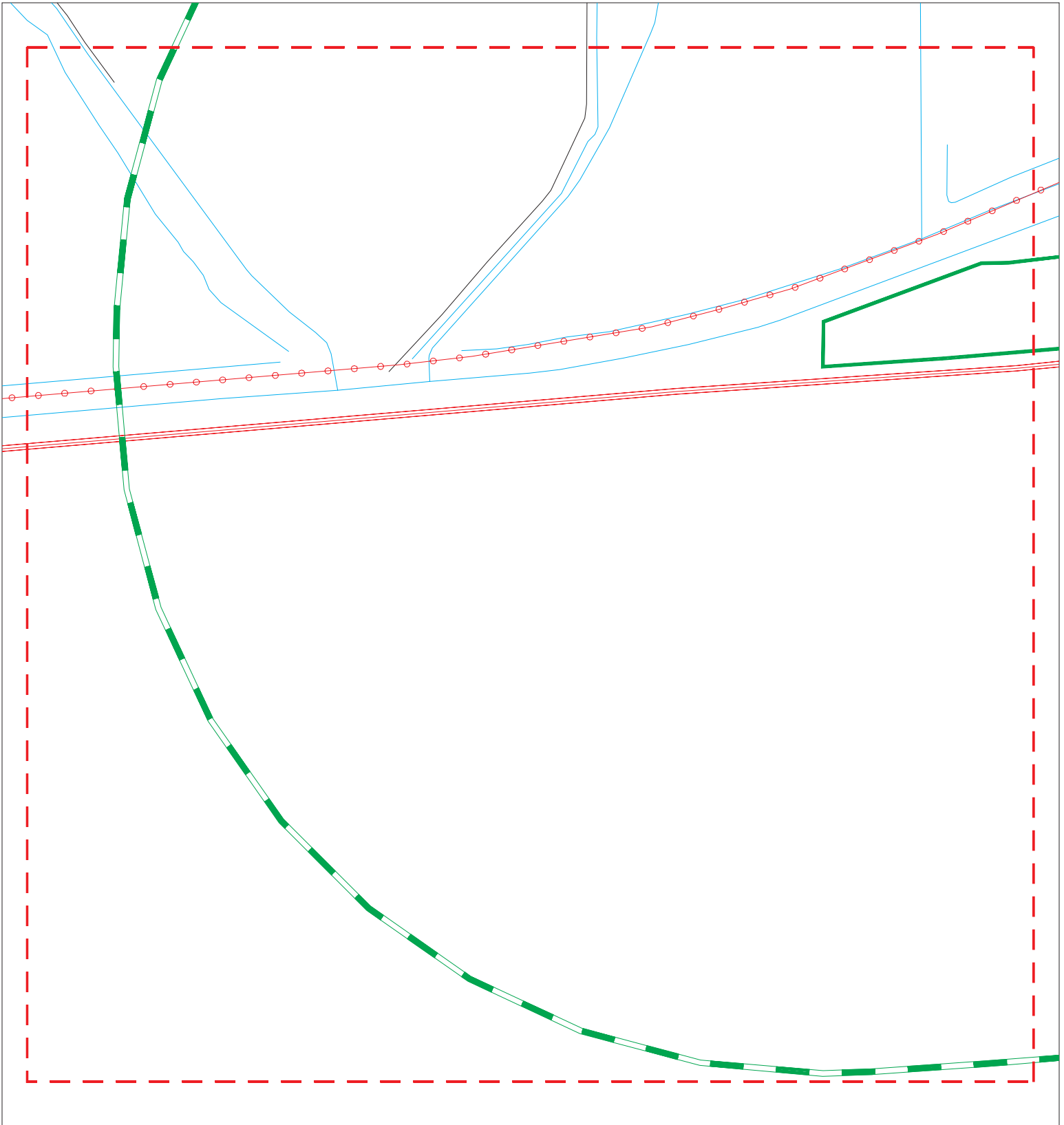
MAPPED SITES SUMMARY - FOCUS MAP 3











Target Property:
SEC ALL AMERICAN CANAL & BONDS CORNER
CALEXICO, CA 92283

MAP ID / FOCUS MAP	SITE NAME	ADDRESS	DATABASE ACRONYMS	DIST (ft. & mi.) DIRECTION
-----------------------	-----------	---------	-------------------	-------------------------------

NO MAPPED SITES FOUND

Focus Map - 4 - 6171645.3s



- | | | | | | |
|------------------------------------------------------------------------------------|----------------------|-------------------------------------------------------------------------------------|------------------------------|-------------------------------------------------------------------------------------|-------------------------|
|  | Sites |  | Focus Map - Sites |  | Dept. Defense Sites |
|  | Target Property |  | Power Line |  | Indian Reservations BIA |
|  | Search Buffer |  | National Priority List Sites |  | Areas of Concern |
|  | Focus Map - No Sites | | | | |



SITE NAME: Cedar Solar 1
ADDRESS: SEC All American Canal & Bonds Corner
CITY/STATE: Calexico CA
ZIP: 92283

CLIENT: GS Lyon Consultants
CONTACT: Peter E. Labrucherie
INQUIRY #: 6171645.3s
DATE: 09/27/20

PC ORIGINAL PKG

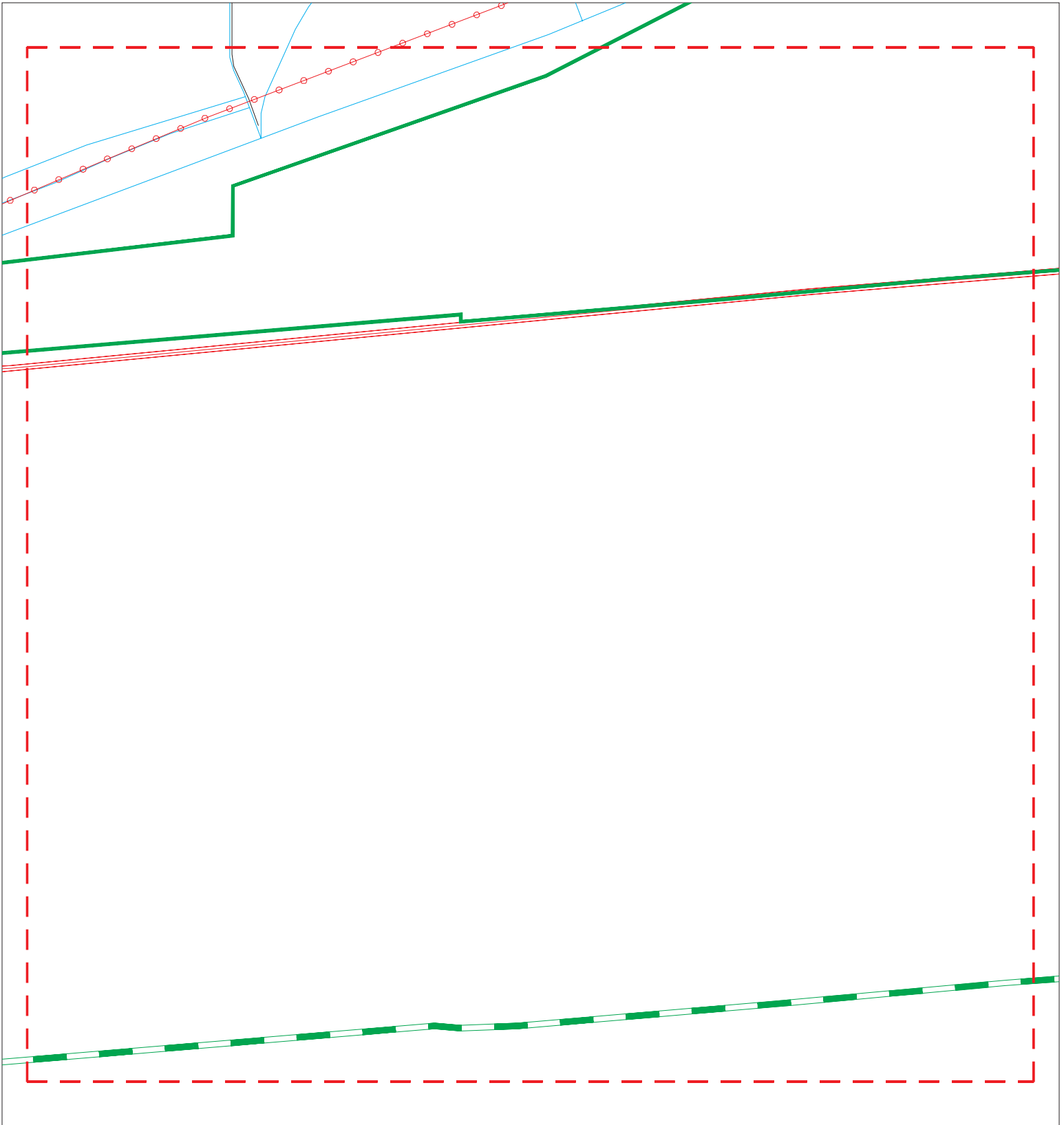
MAPPED SITES SUMMARY - FOCUS MAP 4











Target Property:
SEC ALL AMERICAN CANAL & BONDS CORNER
CALEXICO, CA 92283

MAP ID / FOCUS MAP	SITE NAME	ADDRESS	DATABASE ACRONYMS	DIST (ft. & mi.) DIRECTION
-----------------------	-----------	---------	-------------------	-------------------------------

NO MAPPED SITES FOUND

Focus Map - 5 - 6171645.3s



- | | | |
|---------------------------------------------------------------------------------------------------------|------------------------------------------------------------------------------------------------------------------|-------------------------------------------------------------------------------------------------------------|
|  Sites |  Focus Map - Sites |  Dept. Defense Sites |
|  Target Property |  Power Line |  Indian Reservations BIA |
|  Search Buffer |  National Priority List Sites |  Areas of Concern |
|  Focus Map - No Sites | | |



SITE NAME: Cedar Solar 1
 ADDRESS: SEC All American Canal & Bonds Corner
 CITY/STATE: Calexico CA
 ZIP: 92283

CLIENT: GS Lyon Consultants
 CONTACT: Peter E. Labrucherie
 INQUIRY #: 6171645.3s
 DATE: 09/27/20

PC ORIGINAL PKG

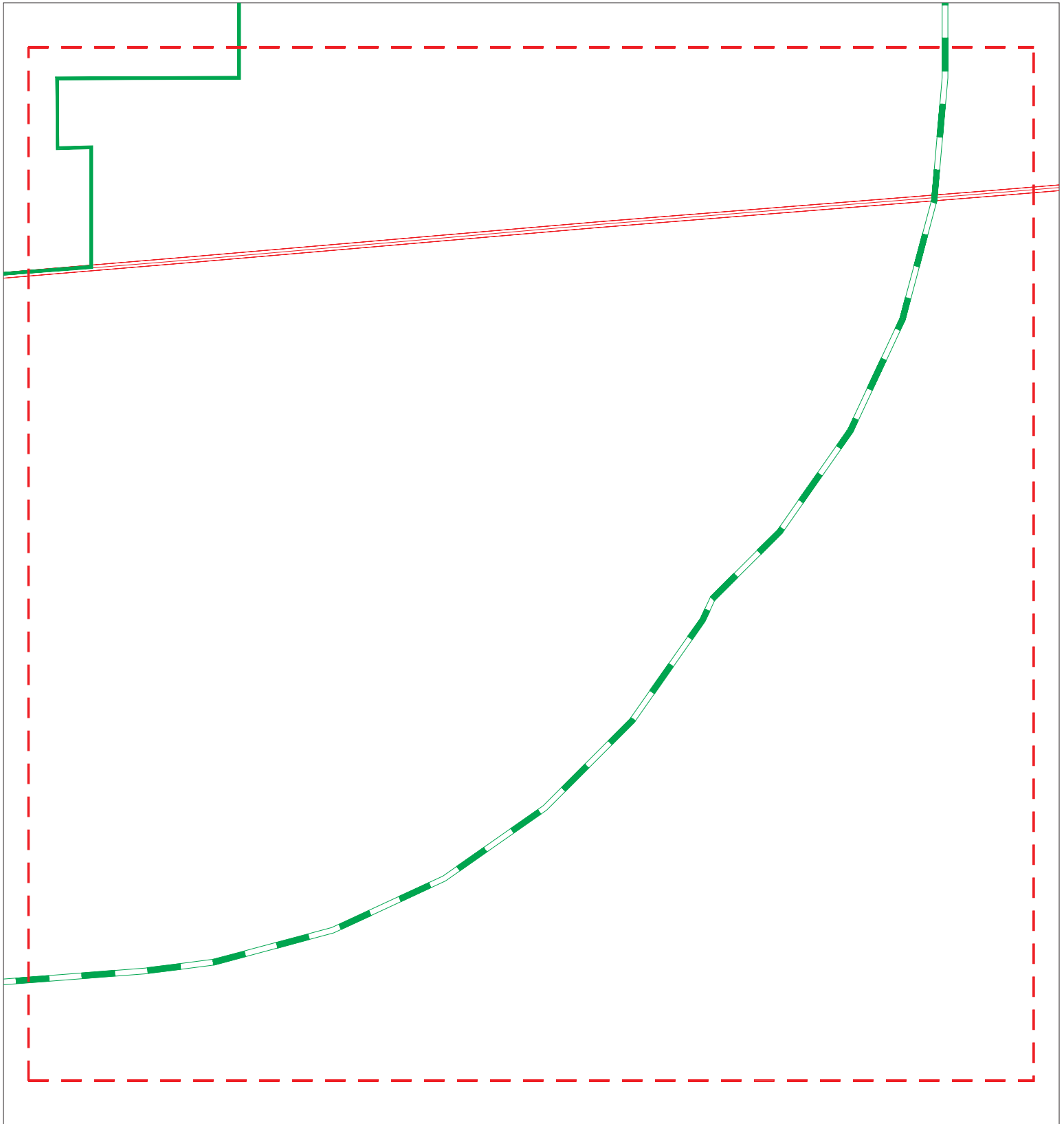
MAPPED SITES SUMMARY - FOCUS MAP 5











Target Property:
SEC ALL AMERICAN CANAL & BONDS CORNER
CALEXICO, CA 92283

MAP ID / FOCUS MAP	SITE NAME	ADDRESS	DATABASE ACRONYMS	DIST (ft. & mi.) DIRECTION
-----------------------	-----------	---------	-------------------	-------------------------------

NO MAPPED SITES FOUND

Focus Map - 6 - 6171645.3s



- | | | | | | |
|------------------------------------------------------------------------------------|----------------------|-------------------------------------------------------------------------------------|------------------------------|-------------------------------------------------------------------------------------|-------------------------|
|  | Sites |  | Focus Map - Sites |  | Dept. Defense Sites |
|  | Target Property |  | Power Line |  | Indian Reservations BIA |
|  | Search Buffer |  | National Priority List Sites |  | Areas of Concern |
|  | Focus Map - No Sites | | | | |



SITE NAME: Cedar Solar 1
 ADDRESS: SEC All American Canal & Bonds Corner
 CITY/STATE: Calexico CA
 ZIP: 92283

CLIENT: GS Lyon Consultants
 CONTACT: Peter E. Labrucherie
 INQUIRY #: 6171645.3s
 DATE: 09/27/20

PC ORIGINAL PKG

MAPPED SITES SUMMARY - FOCUS MAP 6

Target Property:
SEC ALL AMERICAN CANAL & BONDS CORNER
CALEXICO, CA 92283

MAP ID / FOCUS MAP	SITE NAME	ADDRESS	DATABASE ACRONYMS	DIST (ft. & mi.) DIRECTION
-----------------------	-----------	---------	-------------------	-------------------------------

NO MAPPED SITES FOUND

Map ID
Direction
Distance
Elevation

MAP FINDINGS

Site

Database(s)

EDR ID Number
EPA ID Number

NO SITES FOUND

Count: 1 records

ORPHAN SUMMARY

City	EDR ID	Site Name	Site Address	Zip	Database(s)
HOLTVILLE	S117696630	CALTRANS UTILITY RELOCATION PR	16 T16 S R15E SEC 11 12 13 14 23	92250	NPDES, CIWQS

GOVERNMENT RECORDS SEARCHED / DATA CURRENCY TRACKING

To maintain currency of the following federal and state databases, EDR contacts the appropriate governmental agency on a monthly or quarterly basis, as required.

Number of Days to Update: Provides confirmation that EDR is reporting records that have been updated within 90 days from the date the government agency made the information available to the public.

STANDARD ENVIRONMENTAL RECORDS

Federal NPL site list

NPL: National Priority List

National Priorities List (Superfund). The NPL is a subset of CERCLIS and identifies over 1,200 sites for priority cleanup under the Superfund Program. NPL sites may encompass relatively large areas. As such, EDR provides polygon coverage for over 1,000 NPL site boundaries produced by EPA's Environmental Photographic Interpretation Center (EPIC) and regional EPA offices.

Date of Government Version: 07/29/2020	Source: EPA
Date Data Arrived at EDR: 08/03/2020	Telephone: N/A
Date Made Active in Reports: 08/25/2020	Last EDR Contact: 08/03/2020
Number of Days to Update: 22	Next Scheduled EDR Contact: 10/12/2020
	Data Release Frequency: Quarterly

NPL Site Boundaries

Sources:

EPA's Environmental Photographic Interpretation Center (EPIC)
Telephone: 202-564-7333

EPA Region 1
Telephone 617-918-1143

EPA Region 6
Telephone: 214-655-6659

EPA Region 3
Telephone 215-814-5418

EPA Region 7
Telephone: 913-551-7247

EPA Region 4
Telephone 404-562-8033

EPA Region 8
Telephone: 303-312-6774

EPA Region 5
Telephone 312-886-6686

EPA Region 9
Telephone: 415-947-4246

EPA Region 10
Telephone 206-553-8665

Proposed NPL: Proposed National Priority List Sites

A site that has been proposed for listing on the National Priorities List through the issuance of a proposed rule in the Federal Register. EPA then accepts public comments on the site, responds to the comments, and places on the NPL those sites that continue to meet the requirements for listing.

Date of Government Version: 07/29/2020	Source: EPA
Date Data Arrived at EDR: 08/03/2020	Telephone: N/A
Date Made Active in Reports: 08/25/2020	Last EDR Contact: 08/03/2020
Number of Days to Update: 22	Next Scheduled EDR Contact: 10/12/2020
	Data Release Frequency: Quarterly

NPL LIENS: Federal Superfund Liens

Federal Superfund Liens. Under the authority granted the USEPA by CERCLA of 1980, the USEPA has the authority to file liens against real property in order to recover remedial action expenditures or when the property owner received notification of potential liability. USEPA compiles a listing of filed notices of Superfund Liens.

GOVERNMENT RECORDS SEARCHED / DATA CURRENCY TRACKING

Date of Government Version: 10/15/1991
Date Data Arrived at EDR: 02/02/1994
Date Made Active in Reports: 03/30/1994
Number of Days to Update: 56

Source: EPA
Telephone: 202-564-4267
Last EDR Contact: 08/15/2011
Next Scheduled EDR Contact: 11/28/2011
Data Release Frequency: No Update Planned

Federal Delisted NPL site list

Delisted NPL: National Priority List Deletions

The National Oil and Hazardous Substances Pollution Contingency Plan (NCP) establishes the criteria that the EPA uses to delete sites from the NPL. In accordance with 40 CFR 300.425.(e), sites may be deleted from the NPL where no further response is appropriate.

Date of Government Version: 07/29/2020
Date Data Arrived at EDR: 08/03/2020
Date Made Active in Reports: 08/25/2020
Number of Days to Update: 22

Source: EPA
Telephone: N/A
Last EDR Contact: 08/03/2020
Next Scheduled EDR Contact: 10/12/2020
Data Release Frequency: Quarterly

Federal CERCLIS list

FEDERAL FACILITY: Federal Facility Site Information listing

A listing of National Priority List (NPL) and Base Realignment and Closure (BRAC) sites found in the Comprehensive Environmental Response, Compensation and Liability Information System (CERCLIS) Database where EPA Federal Facilities Restoration and Reuse Office is involved in cleanup activities.

Date of Government Version: 04/03/2019
Date Data Arrived at EDR: 04/05/2019
Date Made Active in Reports: 05/14/2019
Number of Days to Update: 39

Source: Environmental Protection Agency
Telephone: 703-603-8704
Last EDR Contact: 07/02/2020
Next Scheduled EDR Contact: 10/12/2020
Data Release Frequency: Varies

SEMS: Superfund Enterprise Management System

SEMS (Superfund Enterprise Management System) tracks hazardous waste sites, potentially hazardous waste sites, and remedial activities performed in support of EPA's Superfund Program across the United States. The list was formerly known as CERCLIS, renamed to SEMS by the EPA in 2015. The list contains data on potentially hazardous waste sites that have been reported to the USEPA by states, municipalities, private companies and private persons, pursuant to Section 103 of the Comprehensive Environmental Response, Compensation, and Liability Act (CERCLA). This dataset also contains sites which are either proposed to or on the National Priorities List (NPL) and the sites which are in the screening and assessment phase for possible inclusion on the NPL.

Date of Government Version: 07/29/2020
Date Data Arrived at EDR: 08/03/2020
Date Made Active in Reports: 08/25/2020
Number of Days to Update: 22

Source: EPA
Telephone: 800-424-9346
Last EDR Contact: 08/03/2020
Next Scheduled EDR Contact: 10/26/2020
Data Release Frequency: Quarterly

Federal CERCLIS NFRAP site list

SEMS-ARCHIVE: Superfund Enterprise Management System Archive

GOVERNMENT RECORDS SEARCHED / DATA CURRENCY TRACKING

SEMS-ARCHIVE (Superfund Enterprise Management System Archive) tracks sites that have no further interest under the Federal Superfund Program based on available information. The list was formerly known as the CERCLIS-NFRAP, renamed to SEMS ARCHIVE by the EPA in 2015. EPA may perform a minimal level of assessment work at a site while it is archived if site conditions change and/or new information becomes available. Archived sites have been removed and archived from the inventory of SEMS sites. Archived status indicates that, to the best of EPA's knowledge, assessment at a site has been completed and that EPA has determined no further steps will be taken to list the site on the National Priorities List (NPL), unless information indicates this decision was not appropriate or other considerations require a recommendation for listing at a later time. The decision does not necessarily mean that there is no hazard associated with a given site; it only means that, based upon available information, the location is not judged to be potential NPL site.

Date of Government Version: 07/29/2020	Source: EPA
Date Data Arrived at EDR: 08/03/2020	Telephone: 800-424-9346
Date Made Active in Reports: 08/25/2020	Last EDR Contact: 08/03/2020
Number of Days to Update: 22	Next Scheduled EDR Contact: 10/26/2020
	Data Release Frequency: Quarterly

Federal RCRA CORRACTS facilities list

CORRACTS: Corrective Action Report

CORRACTS identifies hazardous waste handlers with RCRA corrective action activity.

Date of Government Version: 03/23/2020	Source: EPA
Date Data Arrived at EDR: 03/25/2020	Telephone: 800-424-9346
Date Made Active in Reports: 05/21/2020	Last EDR Contact: 06/22/2020
Number of Days to Update: 57	Next Scheduled EDR Contact: 10/05/2020
	Data Release Frequency: Quarterly

Federal RCRA non-CORRACTS TSD facilities list

RCRA-TSDF: RCRA - Treatment, Storage and Disposal

RCRAInfo is EPA's comprehensive information system, providing access to data supporting the Resource Conservation and Recovery Act (RCRA) of 1976 and the Hazardous and Solid Waste Amendments (HSWA) of 1984. The database includes selective information on sites which generate, transport, store, treat and/or dispose of hazardous waste as defined by the Resource Conservation and Recovery Act (RCRA). Transporters are individuals or entities that move hazardous waste from the generator offsite to a facility that can recycle, treat, store, or dispose of the waste. TSDFs treat, store, or dispose of the waste.

Date of Government Version: 03/23/2020	Source: Environmental Protection Agency
Date Data Arrived at EDR: 03/25/2020	Telephone: (415) 495-8895
Date Made Active in Reports: 05/21/2020	Last EDR Contact: 06/22/2020
Number of Days to Update: 57	Next Scheduled EDR Contact: 10/05/2020
	Data Release Frequency: Quarterly

Federal RCRA generators list

RCRA-LQG: RCRA - Large Quantity Generators

RCRAInfo is EPA's comprehensive information system, providing access to data supporting the Resource Conservation and Recovery Act (RCRA) of 1976 and the Hazardous and Solid Waste Amendments (HSWA) of 1984. The database includes selective information on sites which generate, transport, store, treat and/or dispose of hazardous waste as defined by the Resource Conservation and Recovery Act (RCRA). Large quantity generators (LQGs) generate over 1,000 kilograms (kg) of hazardous waste, or over 1 kg of acutely hazardous waste per month.

Date of Government Version: 03/23/2020	Source: Environmental Protection Agency
Date Data Arrived at EDR: 03/25/2020	Telephone: (415) 495-8895
Date Made Active in Reports: 05/21/2020	Last EDR Contact: 06/22/2020
Number of Days to Update: 57	Next Scheduled EDR Contact: 10/05/2020
	Data Release Frequency: Quarterly

GOVERNMENT RECORDS SEARCHED / DATA CURRENCY TRACKING

RCRA-SQG: RCRA - Small Quantity Generators

RCRAInfo is EPA's comprehensive information system, providing access to data supporting the Resource Conservation and Recovery Act (RCRA) of 1976 and the Hazardous and Solid Waste Amendments (HSWA) of 1984. The database includes selective information on sites which generate, transport, store, treat and/or dispose of hazardous waste as defined by the Resource Conservation and Recovery Act (RCRA). Small quantity generators (SQGs) generate between 100 kg and 1,000 kg of hazardous waste per month.

Date of Government Version: 03/23/2020	Source: Environmental Protection Agency
Date Data Arrived at EDR: 03/25/2020	Telephone: (415) 495-8895
Date Made Active in Reports: 05/21/2020	Last EDR Contact: 06/22/2020
Number of Days to Update: 57	Next Scheduled EDR Contact: 10/05/2020
	Data Release Frequency: Quarterly

RCRA-VSQG: RCRA - Very Small Quantity Generators (Formerly Conditionally Exempt Small Quantity Generators)

RCRAInfo is EPA's comprehensive information system, providing access to data supporting the Resource Conservation and Recovery Act (RCRA) of 1976 and the Hazardous and Solid Waste Amendments (HSWA) of 1984. The database includes selective information on sites which generate, transport, store, treat and/or dispose of hazardous waste as defined by the Resource Conservation and Recovery Act (RCRA). Very small quantity generators (VSQGs) generate less than 100 kg of hazardous waste, or less than 1 kg of acutely hazardous waste per month.

Date of Government Version: 03/23/2020	Source: Environmental Protection Agency
Date Data Arrived at EDR: 03/25/2020	Telephone: (415) 495-8895
Date Made Active in Reports: 05/21/2020	Last EDR Contact: 06/22/2020
Number of Days to Update: 57	Next Scheduled EDR Contact: 10/05/2020
	Data Release Frequency: Quarterly

Federal institutional controls / engineering controls registries

LUCIS: Land Use Control Information System

LUCIS contains records of land use control information pertaining to the former Navy Base Realignment and Closure properties.

Date of Government Version: 05/15/2020	Source: Department of the Navy
Date Data Arrived at EDR: 05/19/2020	Telephone: 843-820-7326
Date Made Active in Reports: 06/18/2020	Last EDR Contact: 08/04/2020
Number of Days to Update: 30	Next Scheduled EDR Contact: 11/23/2020
	Data Release Frequency: Varies

US ENG CONTROLS: Engineering Controls Sites List

A listing of sites with engineering controls in place. Engineering controls include various forms of caps, building foundations, liners, and treatment methods to create pathway elimination for regulated substances to enter environmental media or effect human health.

Date of Government Version: 02/13/2020	Source: Environmental Protection Agency
Date Data Arrived at EDR: 02/20/2020	Telephone: 703-603-0695
Date Made Active in Reports: 05/15/2020	Last EDR Contact: 08/24/2020
Number of Days to Update: 85	Next Scheduled EDR Contact: 09/07/2020
	Data Release Frequency: Varies

US INST CONTROLS: Institutional Controls Sites List

A listing of sites with institutional controls in place. Institutional controls include administrative measures, such as groundwater use restrictions, construction restrictions, property use restrictions, and post remediation care requirements intended to prevent exposure to contaminants remaining on site. Deed restrictions are generally required as part of the institutional controls.

Date of Government Version: 02/13/2020	Source: Environmental Protection Agency
Date Data Arrived at EDR: 02/20/2020	Telephone: 703-603-0695
Date Made Active in Reports: 05/15/2020	Last EDR Contact: 08/24/2020
Number of Days to Update: 85	Next Scheduled EDR Contact: 12/07/2020
	Data Release Frequency: Varies

GOVERNMENT RECORDS SEARCHED / DATA CURRENCY TRACKING

Federal ERNS list

ERNS: Emergency Response Notification System

Emergency Response Notification System. ERNS records and stores information on reported releases of oil and hazardous substances.

Date of Government Version: 03/22/2020

Date Data Arrived at EDR: 03/24/2020

Date Made Active in Reports: 06/18/2020

Number of Days to Update: 86

Source: National Response Center, United States Coast Guard

Telephone: 202-267-2180

Last EDR Contact: 06/22/2020

Next Scheduled EDR Contact: 10/05/2020

Data Release Frequency: Quarterly

State- and tribal - equivalent NPL

RESPONSE: State Response Sites

Identifies confirmed release sites where DTSC is involved in remediation, either in a lead or oversight capacity.

These confirmed release sites are generally high-priority and high potential risk.

Date of Government Version: 04/27/2020

Date Data Arrived at EDR: 04/28/2020

Date Made Active in Reports: 07/13/2020

Number of Days to Update: 76

Source: Department of Toxic Substances Control

Telephone: 916-323-3400

Last EDR Contact: 07/27/2020

Next Scheduled EDR Contact: 11/09/2020

Data Release Frequency: Quarterly

State- and tribal - equivalent CERCLIS

ENVIROSTOR: EnviroStor Database

The Department of Toxic Substances Control's (DTSC's) Site Mitigation and Brownfields Reuse Program's (SMBRP's) EnviroStor database identifies sites that have known contamination or sites for which there may be reasons to investigate further. The database includes the following site types: Federal Superfund sites (National Priorities List (NPL)); State Response, including Military Facilities and State Superfund; Voluntary Cleanup; and School sites. EnviroStor provides similar information to the information that was available in CalSites, and provides additional site information, including, but not limited to, identification of formerly-contaminated properties that have been released for reuse, properties where environmental deed restrictions have been recorded to prevent inappropriate land uses, and risk characterization information that is used to assess potential impacts to public health and the environment at contaminated sites.

Date of Government Version: 04/27/2020

Date Data Arrived at EDR: 04/28/2020

Date Made Active in Reports: 07/13/2020

Number of Days to Update: 76

Source: Department of Toxic Substances Control

Telephone: 916-323-3400

Last EDR Contact: 07/27/2020

Next Scheduled EDR Contact: 11/09/2020

Data Release Frequency: Quarterly

State and tribal landfill and/or solid waste disposal site lists

SWF/LF (SWIS): Solid Waste Information System

Active, Closed and Inactive Landfills. SWF/LF records typically contain an inventory of solid waste disposal facilities or landfills. These may be active or inactive facilities or open dumps that failed to meet RCRA Section 4004 criteria for solid waste landfills or disposal sites.

Date of Government Version: 05/11/2020

Date Data Arrived at EDR: 05/12/2020

Date Made Active in Reports: 07/27/2020

Number of Days to Update: 76

Source: Department of Resources Recycling and Recovery

Telephone: 916-341-6320

Last EDR Contact: 08/10/2020

Next Scheduled EDR Contact: 11/23/2020

Data Release Frequency: Quarterly

State and tribal leaking storage tank lists

GOVERNMENT RECORDS SEARCHED / DATA CURRENCY TRACKING

LUST REG 2: Fuel Leak List

Leaking Underground Storage Tank locations. Alameda, Contra Costa, Marin, Napa, San Francisco, San Mateo, Santa Clara, Solano, Sonoma counties.

Date of Government Version: 09/30/2004
Date Data Arrived at EDR: 10/20/2004
Date Made Active in Reports: 11/19/2004
Number of Days to Update: 30

Source: California Regional Water Quality Control Board San Francisco Bay Region (2)
Telephone: 510-622-2433
Last EDR Contact: 09/19/2011
Next Scheduled EDR Contact: 01/02/2012
Data Release Frequency: No Update Planned

LUST REG 3: Leaking Underground Storage Tank Database

Leaking Underground Storage Tank locations. Monterey, San Benito, San Luis Obispo, Santa Barbara, Santa Cruz counties.

Date of Government Version: 05/19/2003
Date Data Arrived at EDR: 05/19/2003
Date Made Active in Reports: 06/02/2003
Number of Days to Update: 14

Source: California Regional Water Quality Control Board Central Coast Region (3)
Telephone: 805-542-4786
Last EDR Contact: 07/18/2011
Next Scheduled EDR Contact: 10/31/2011
Data Release Frequency: No Update Planned

LUST REG 4: Underground Storage Tank Leak List

Los Angeles, Ventura counties. For more current information, please refer to the State Water Resources Control Board's LUST database.

Date of Government Version: 09/07/2004
Date Data Arrived at EDR: 09/07/2004
Date Made Active in Reports: 10/12/2004
Number of Days to Update: 35

Source: California Regional Water Quality Control Board Los Angeles Region (4)
Telephone: 213-576-6710
Last EDR Contact: 09/06/2011
Next Scheduled EDR Contact: 12/19/2011
Data Release Frequency: No Update Planned

LUST REG 9: Leaking Underground Storage Tank Report

Orange, Riverside, San Diego counties. For more current information, please refer to the State Water Resources Control Board's LUST database.

Date of Government Version: 03/01/2001
Date Data Arrived at EDR: 04/23/2001
Date Made Active in Reports: 05/21/2001
Number of Days to Update: 28

Source: California Regional Water Quality Control Board San Diego Region (9)
Telephone: 858-637-5595
Last EDR Contact: 09/26/2011
Next Scheduled EDR Contact: 01/09/2012
Data Release Frequency: No Update Planned

LUST REG 8: Leaking Underground Storage Tanks

California Regional Water Quality Control Board Santa Ana Region (8). For more current information, please refer to the State Water Resources Control Board's LUST database.

Date of Government Version: 02/14/2005
Date Data Arrived at EDR: 02/15/2005
Date Made Active in Reports: 03/28/2005
Number of Days to Update: 41

Source: California Regional Water Quality Control Board Santa Ana Region (8)
Telephone: 909-782-4496
Last EDR Contact: 08/15/2011
Next Scheduled EDR Contact: 11/28/2011
Data Release Frequency: No Update Planned

LUST REG 5: Leaking Underground Storage Tank Database

Leaking Underground Storage Tank locations. Alameda, Alpine, Amador, Butte, Colusa, Contra Costa, Calveras, El Dorado, Fresno, Glenn, Kern, Kings, Lake, Lassen, Madera, Mariposa, Merced, Modoc, Napa, Nevada, Placer, Plumas, Sacramento, San Joaquin, Shasta, Solano, Stanislaus, Sutter, Tehama, Tulare, Tuolumne, Yolo, Yuba counties.

Date of Government Version: 07/01/2008
Date Data Arrived at EDR: 07/22/2008
Date Made Active in Reports: 07/31/2008
Number of Days to Update: 9

Source: California Regional Water Quality Control Board Central Valley Region (5)
Telephone: 916-464-4834
Last EDR Contact: 07/01/2011
Next Scheduled EDR Contact: 10/17/2011
Data Release Frequency: No Update Planned

GOVERNMENT RECORDS SEARCHED / DATA CURRENCY TRACKING

LUST REG 6L: Leaking Underground Storage Tank Case Listing

For more current information, please refer to the State Water Resources Control Board's LUST database.

Date of Government Version: 09/09/2003	Source: California Regional Water Quality Control Board Lahontan Region (6)
Date Data Arrived at EDR: 09/10/2003	Telephone: 530-542-5572
Date Made Active in Reports: 10/07/2003	Last EDR Contact: 09/12/2011
Number of Days to Update: 27	Next Scheduled EDR Contact: 12/26/2011
	Data Release Frequency: No Update Planned

LUST REG 6V: Leaking Underground Storage Tank Case Listing

Leaking Underground Storage Tank locations. Inyo, Kern, Los Angeles, Mono, San Bernardino counties.

Date of Government Version: 06/07/2005	Source: California Regional Water Quality Control Board Victorville Branch Office (6)
Date Data Arrived at EDR: 06/07/2005	Telephone: 760-241-7365
Date Made Active in Reports: 06/29/2005	Last EDR Contact: 09/12/2011
Number of Days to Update: 22	Next Scheduled EDR Contact: 12/26/2011
	Data Release Frequency: No Update Planned

LUST REG 1: Active Toxic Site Investigation

Del Norte, Humboldt, Lake, Mendocino, Modoc, Siskiyou, Sonoma, Trinity counties. For more current information, please refer to the State Water Resources Control Board's LUST database.

Date of Government Version: 02/01/2001	Source: California Regional Water Quality Control Board North Coast (1)
Date Data Arrived at EDR: 02/28/2001	Telephone: 707-570-3769
Date Made Active in Reports: 03/29/2001	Last EDR Contact: 08/01/2011
Number of Days to Update: 29	Next Scheduled EDR Contact: 11/14/2011
	Data Release Frequency: No Update Planned

LUST REG 7: Leaking Underground Storage Tank Case Listing

Leaking Underground Storage Tank locations. Imperial, Riverside, San Diego, Santa Barbara counties.

Date of Government Version: 02/26/2004	Source: California Regional Water Quality Control Board Colorado River Basin Region (7)
Date Data Arrived at EDR: 02/26/2004	Telephone: 760-776-8943
Date Made Active in Reports: 03/24/2004	Last EDR Contact: 08/01/2011
Number of Days to Update: 27	Next Scheduled EDR Contact: 11/14/2011
	Data Release Frequency: No Update Planned

LUST: Leaking Underground Fuel Tank Report (GEOTRACKER)

Leaking Underground Storage Tank (LUST) Sites included in GeoTracker. GeoTracker is the Water Boards data management system for sites that impact, or have the potential to impact, water quality in California, with emphasis on groundwater.

Date of Government Version: 06/08/2020	Source: State Water Resources Control Board
Date Data Arrived at EDR: 06/09/2020	Telephone: see region list
Date Made Active in Reports: 08/19/2020	Last EDR Contact: 06/09/2020
Number of Days to Update: 71	Next Scheduled EDR Contact: 09/21/2020
	Data Release Frequency: Quarterly

INDIAN LUST R10: Leaking Underground Storage Tanks on Indian Land

LUSTs on Indian land in Alaska, Idaho, Oregon and Washington.

Date of Government Version: 04/14/2020	Source: EPA Region 10
Date Data Arrived at EDR: 05/20/2020	Telephone: 206-553-2857
Date Made Active in Reports: 08/12/2020	Last EDR Contact: 07/24/2020
Number of Days to Update: 84	Next Scheduled EDR Contact: 11/02/2020
	Data Release Frequency: Varies

INDIAN LUST R4: Leaking Underground Storage Tanks on Indian Land

LUSTs on Indian land in Florida, Mississippi and North Carolina.

Date of Government Version: 04/14/2020	Source: EPA Region 4
Date Data Arrived at EDR: 05/26/2020	Telephone: 404-562-8677
Date Made Active in Reports: 08/12/2020	Last EDR Contact: 07/24/2020
Number of Days to Update: 78	Next Scheduled EDR Contact: 11/02/2020
	Data Release Frequency: Varies

GOVERNMENT RECORDS SEARCHED / DATA CURRENCY TRACKING

INDIAN LUST R5: Leaking Underground Storage Tanks on Indian Land

Leaking underground storage tanks located on Indian Land in Michigan, Minnesota and Wisconsin.

Date of Government Version: 04/14/2020	Source: EPA, Region 5
Date Data Arrived at EDR: 05/20/2020	Telephone: 312-886-7439
Date Made Active in Reports: 08/12/2020	Last EDR Contact: 07/24/2020
Number of Days to Update: 84	Next Scheduled EDR Contact: 11/02/2020
	Data Release Frequency: Varies

INDIAN LUST R1: Leaking Underground Storage Tanks on Indian Land

A listing of leaking underground storage tank locations on Indian Land.

Date of Government Version: 04/29/2020	Source: EPA Region 1
Date Data Arrived at EDR: 05/20/2020	Telephone: 617-918-1313
Date Made Active in Reports: 08/12/2020	Last EDR Contact: 07/24/2020
Number of Days to Update: 84	Next Scheduled EDR Contact: 11/02/2020
	Data Release Frequency: Varies

INDIAN LUST R6: Leaking Underground Storage Tanks on Indian Land

LUSTs on Indian land in New Mexico and Oklahoma.

Date of Government Version: 04/08/2020	Source: EPA Region 6
Date Data Arrived at EDR: 05/20/2020	Telephone: 214-665-6597
Date Made Active in Reports: 08/12/2020	Last EDR Contact: 07/24/2020
Number of Days to Update: 84	Next Scheduled EDR Contact: 11/02/2020
	Data Release Frequency: Varies

INDIAN LUST R7: Leaking Underground Storage Tanks on Indian Land

LUSTs on Indian land in Iowa, Kansas, and Nebraska

Date of Government Version: 04/15/2020	Source: EPA Region 7
Date Data Arrived at EDR: 05/20/2020	Telephone: 913-551-7003
Date Made Active in Reports: 08/12/2020	Last EDR Contact: 07/24/2020
Number of Days to Update: 84	Next Scheduled EDR Contact: 11/02/2020
	Data Release Frequency: Varies

INDIAN LUST R8: Leaking Underground Storage Tanks on Indian Land

LUSTs on Indian land in Colorado, Montana, North Dakota, South Dakota, Utah and Wyoming.

Date of Government Version: 04/14/2020	Source: EPA Region 8
Date Data Arrived at EDR: 05/20/2020	Telephone: 303-312-6271
Date Made Active in Reports: 08/12/2020	Last EDR Contact: 07/24/2020
Number of Days to Update: 84	Next Scheduled EDR Contact: 11/02/2020
	Data Release Frequency: Varies

INDIAN LUST R9: Leaking Underground Storage Tanks on Indian Land

LUSTs on Indian land in Arizona, California, New Mexico and Nevada

Date of Government Version: 04/08/2020	Source: Environmental Protection Agency
Date Data Arrived at EDR: 05/20/2020	Telephone: 415-972-3372
Date Made Active in Reports: 08/12/2020	Last EDR Contact: 07/24/2020
Number of Days to Update: 84	Next Scheduled EDR Contact: 11/02/2020
	Data Release Frequency: Varies

CPS-SLIC: Statewide SLIC Cases (GEOTRACKER)

Cleanup Program Sites (CPS; also known as Site Cleanups [SC] and formerly known as Spills, Leaks, Investigations, and Cleanups [SLIC] sites) included in GeoTracker. GeoTracker is the Water Boards data management system for sites that impact, or have the potential to impact, water quality in California, with emphasis on groundwater.

Date of Government Version: 06/08/2020	Source: State Water Resources Control Board
Date Data Arrived at EDR: 06/09/2020	Telephone: 866-480-1028
Date Made Active in Reports: 08/19/2020	Last EDR Contact: 06/09/2020
Number of Days to Update: 71	Next Scheduled EDR Contact: 09/21/2020
	Data Release Frequency: Varies

GOVERNMENT RECORDS SEARCHED / DATA CURRENCY TRACKING

SLIC REG 1: Active Toxic Site Investigations

The SLIC (Spills, Leaks, Investigations and Cleanup) program is designed to protect and restore water quality from spills, leaks, and similar discharges.

Date of Government Version: 04/03/2003
Date Data Arrived at EDR: 04/07/2003
Date Made Active in Reports: 04/25/2003
Number of Days to Update: 18

Source: California Regional Water Quality Control Board, North Coast Region (1)
Telephone: 707-576-2220
Last EDR Contact: 08/01/2011
Next Scheduled EDR Contact: 11/14/2011
Data Release Frequency: No Update Planned

SLIC REG 2: Spills, Leaks, Investigation & Cleanup Cost Recovery Listing

The SLIC (Spills, Leaks, Investigations and Cleanup) program is designed to protect and restore water quality from spills, leaks, and similar discharges.

Date of Government Version: 09/30/2004
Date Data Arrived at EDR: 10/20/2004
Date Made Active in Reports: 11/19/2004
Number of Days to Update: 30

Source: Regional Water Quality Control Board San Francisco Bay Region (2)
Telephone: 510-286-0457
Last EDR Contact: 09/19/2011
Next Scheduled EDR Contact: 01/02/2012
Data Release Frequency: No Update Planned

SLIC REG 3: Spills, Leaks, Investigation & Cleanup Cost Recovery Listing

The SLIC (Spills, Leaks, Investigations and Cleanup) program is designed to protect and restore water quality from spills, leaks, and similar discharges.

Date of Government Version: 05/18/2006
Date Data Arrived at EDR: 05/18/2006
Date Made Active in Reports: 06/15/2006
Number of Days to Update: 28

Source: California Regional Water Quality Control Board Central Coast Region (3)
Telephone: 805-549-3147
Last EDR Contact: 07/18/2011
Next Scheduled EDR Contact: 10/31/2011
Data Release Frequency: No Update Planned

SLIC REG 4: Spills, Leaks, Investigation & Cleanup Cost Recovery Listing

The SLIC (Spills, Leaks, Investigations and Cleanup) program is designed to protect and restore water quality from spills, leaks, and similar discharges.

Date of Government Version: 11/17/2004
Date Data Arrived at EDR: 11/18/2004
Date Made Active in Reports: 01/04/2005
Number of Days to Update: 47

Source: Region Water Quality Control Board Los Angeles Region (4)
Telephone: 213-576-6600
Last EDR Contact: 07/01/2011
Next Scheduled EDR Contact: 10/17/2011
Data Release Frequency: No Update Planned

SLIC REG 5: Spills, Leaks, Investigation & Cleanup Cost Recovery Listing

The SLIC (Spills, Leaks, Investigations and Cleanup) program is designed to protect and restore water quality from spills, leaks, and similar discharges.

Date of Government Version: 04/01/2005
Date Data Arrived at EDR: 04/05/2005
Date Made Active in Reports: 04/21/2005
Number of Days to Update: 16

Source: Regional Water Quality Control Board Central Valley Region (5)
Telephone: 916-464-3291
Last EDR Contact: 09/12/2011
Next Scheduled EDR Contact: 12/26/2011
Data Release Frequency: No Update Planned

SLIC REG 6V: Spills, Leaks, Investigation & Cleanup Cost Recovery Listing

The SLIC (Spills, Leaks, Investigations and Cleanup) program is designed to protect and restore water quality from spills, leaks, and similar discharges.

Date of Government Version: 05/24/2005
Date Data Arrived at EDR: 05/25/2005
Date Made Active in Reports: 06/16/2005
Number of Days to Update: 22

Source: Regional Water Quality Control Board, Victorville Branch
Telephone: 619-241-6583
Last EDR Contact: 08/15/2011
Next Scheduled EDR Contact: 11/28/2011
Data Release Frequency: No Update Planned

GOVERNMENT RECORDS SEARCHED / DATA CURRENCY TRACKING

SLIC REG 6L: SLIC Sites

The SLIC (Spills, Leaks, Investigations and Cleanup) program is designed to protect and restore water quality from spills, leaks, and similar discharges.

Date of Government Version: 09/07/2004
Date Data Arrived at EDR: 09/07/2004
Date Made Active in Reports: 10/12/2004
Number of Days to Update: 35

Source: California Regional Water Quality Control Board, Lahontan Region
Telephone: 530-542-5574
Last EDR Contact: 08/15/2011
Next Scheduled EDR Contact: 11/28/2011
Data Release Frequency: No Update Planned

SLIC REG 7: SLIC List

The SLIC (Spills, Leaks, Investigations and Cleanup) program is designed to protect and restore water quality from spills, leaks, and similar discharges.

Date of Government Version: 11/24/2004
Date Data Arrived at EDR: 11/29/2004
Date Made Active in Reports: 01/04/2005
Number of Days to Update: 36

Source: California Regional Quality Control Board, Colorado River Basin Region
Telephone: 760-346-7491
Last EDR Contact: 08/01/2011
Next Scheduled EDR Contact: 11/14/2011
Data Release Frequency: No Update Planned

SLIC REG 8: Spills, Leaks, Investigation & Cleanup Cost Recovery Listing

The SLIC (Spills, Leaks, Investigations and Cleanup) program is designed to protect and restore water quality from spills, leaks, and similar discharges.

Date of Government Version: 04/03/2008
Date Data Arrived at EDR: 04/03/2008
Date Made Active in Reports: 04/14/2008
Number of Days to Update: 11

Source: California Region Water Quality Control Board Santa Ana Region (8)
Telephone: 951-782-3298
Last EDR Contact: 09/12/2011
Next Scheduled EDR Contact: 12/26/2011
Data Release Frequency: No Update Planned

SLIC REG 9: Spills, Leaks, Investigation & Cleanup Cost Recovery Listing

The SLIC (Spills, Leaks, Investigations and Cleanup) program is designed to protect and restore water quality from spills, leaks, and similar discharges.

Date of Government Version: 09/10/2007
Date Data Arrived at EDR: 09/11/2007
Date Made Active in Reports: 09/28/2007
Number of Days to Update: 17

Source: California Regional Water Quality Control Board San Diego Region (9)
Telephone: 858-467-2980
Last EDR Contact: 08/08/2011
Next Scheduled EDR Contact: 11/21/2011
Data Release Frequency: No Update Planned

State and tribal registered storage tank lists

FEMA UST: Underground Storage Tank Listing

A listing of all FEMA owned underground storage tanks.

Date of Government Version: 02/01/2020
Date Data Arrived at EDR: 03/19/2020
Date Made Active in Reports: 06/09/2020
Number of Days to Update: 82

Source: FEMA
Telephone: 202-646-5797
Last EDR Contact: 07/06/2020
Next Scheduled EDR Contact: 10/19/2020
Data Release Frequency: Varies

MILITARY UST SITES: Military UST Sites (GEOTRACKER)

Military ust sites

Date of Government Version: 06/08/2020
Date Data Arrived at EDR: 06/09/2020
Date Made Active in Reports: 08/19/2020
Number of Days to Update: 71

Source: State Water Resources Control Board
Telephone: 866-480-1028
Last EDR Contact: 06/09/2020
Next Scheduled EDR Contact: 09/21/2020
Data Release Frequency: Varies

GOVERNMENT RECORDS SEARCHED / DATA CURRENCY TRACKING

UST: Active UST Facilities

Active UST facilities gathered from the local regulatory agencies

Date of Government Version: 06/08/2020	Source: SWRCB
Date Data Arrived at EDR: 06/09/2020	Telephone: 916-341-5851
Date Made Active in Reports: 08/20/2020	Last EDR Contact: 06/09/2020
Number of Days to Update: 72	Next Scheduled EDR Contact: 09/21/2020
	Data Release Frequency: Semi-Annually

UST CLOSURE: Proposed Closure of Underground Storage Tank (UST) Cases

UST cases that are being considered for closure by either the State Water Resources Control Board or the Executive Director have been posted for a 60-day public comment period. UST Case Closures being proposed for consideration by the State Water Resources Control Board. These are primarily UST cases that meet closure criteria under the decisional framework in State Water Board Resolution No. 92-49 and other Board orders. UST Case Closures proposed for consideration by the Executive Director pursuant to State Water Board Resolution No. 2012-0061. These are cases that meet the criteria of the Low-Threat UST Case Closure Policy. UST Case Closure Review Denials and Approved Orders.

Date of Government Version: 05/26/2020	Source: State Water Resources Control Board
Date Data Arrived at EDR: 06/09/2020	Telephone: 916-327-7844
Date Made Active in Reports: 08/20/2020	Last EDR Contact: 06/09/2020
Number of Days to Update: 72	Next Scheduled EDR Contact: 09/21/2020
	Data Release Frequency: Varies

AST: Aboveground Petroleum Storage Tank Facilities

A listing of aboveground storage tank petroleum storage tank locations.

Date of Government Version: 07/06/2016	Source: California Environmental Protection Agency
Date Data Arrived at EDR: 07/12/2016	Telephone: 916-327-5092
Date Made Active in Reports: 09/19/2016	Last EDR Contact: 06/10/2020
Number of Days to Update: 69	Next Scheduled EDR Contact: 09/28/2020
	Data Release Frequency: Varies

INDIAN UST R4: Underground Storage Tanks on Indian Land

The Indian Underground Storage Tank (UST) database provides information about underground storage tanks on Indian land in EPA Region 4 (Alabama, Florida, Georgia, Kentucky, Mississippi, North Carolina, South Carolina, Tennessee and Tribal Nations)

Date of Government Version: 04/14/2020	Source: EPA Region 4
Date Data Arrived at EDR: 05/26/2020	Telephone: 404-562-9424
Date Made Active in Reports: 08/12/2020	Last EDR Contact: 07/24/2020
Number of Days to Update: 78	Next Scheduled EDR Contact: 11/02/2020
	Data Release Frequency: Varies

INDIAN UST R5: Underground Storage Tanks on Indian Land

The Indian Underground Storage Tank (UST) database provides information about underground storage tanks on Indian land in EPA Region 5 (Michigan, Minnesota and Wisconsin and Tribal Nations).

Date of Government Version: 04/14/2020	Source: EPA Region 5
Date Data Arrived at EDR: 05/20/2020	Telephone: 312-886-6136
Date Made Active in Reports: 08/12/2020	Last EDR Contact: 07/24/2020
Number of Days to Update: 84	Next Scheduled EDR Contact: 11/02/2020
	Data Release Frequency: Varies

INDIAN UST R10: Underground Storage Tanks on Indian Land

The Indian Underground Storage Tank (UST) database provides information about underground storage tanks on Indian land in EPA Region 10 (Alaska, Idaho, Oregon, Washington, and Tribal Nations).

Date of Government Version: 04/14/2020	Source: EPA Region 10
Date Data Arrived at EDR: 05/20/2020	Telephone: 206-553-2857
Date Made Active in Reports: 08/12/2020	Last EDR Contact: 07/24/2020
Number of Days to Update: 84	Next Scheduled EDR Contact: 11/02/2020
	Data Release Frequency: Varies

GOVERNMENT RECORDS SEARCHED / DATA CURRENCY TRACKING

INDIAN UST R7: Underground Storage Tanks on Indian Land

The Indian Underground Storage Tank (UST) database provides information about underground storage tanks on Indian land in EPA Region 7 (Iowa, Kansas, Missouri, Nebraska, and 9 Tribal Nations).

Date of Government Version: 04/03/2020	Source: EPA Region 7
Date Data Arrived at EDR: 05/20/2020	Telephone: 913-551-7003
Date Made Active in Reports: 08/12/2020	Last EDR Contact: 07/24/2020
Number of Days to Update: 84	Next Scheduled EDR Contact: 11/02/2020
	Data Release Frequency: Varies

INDIAN UST R6: Underground Storage Tanks on Indian Land

The Indian Underground Storage Tank (UST) database provides information about underground storage tanks on Indian land in EPA Region 6 (Louisiana, Arkansas, Oklahoma, New Mexico, Texas and 65 Tribes).

Date of Government Version: 04/08/2020	Source: EPA Region 6
Date Data Arrived at EDR: 05/20/2020	Telephone: 214-665-7591
Date Made Active in Reports: 08/12/2020	Last EDR Contact: 07/24/2020
Number of Days to Update: 84	Next Scheduled EDR Contact: 11/02/2020
	Data Release Frequency: Varies

INDIAN UST R9: Underground Storage Tanks on Indian Land

The Indian Underground Storage Tank (UST) database provides information about underground storage tanks on Indian land in EPA Region 9 (Arizona, California, Hawaii, Nevada, the Pacific Islands, and Tribal Nations).

Date of Government Version: 04/08/2020	Source: EPA Region 9
Date Data Arrived at EDR: 05/20/2020	Telephone: 415-972-3368
Date Made Active in Reports: 08/12/2020	Last EDR Contact: 07/23/2020
Number of Days to Update: 84	Next Scheduled EDR Contact: 11/01/2020
	Data Release Frequency: Varies

INDIAN UST R1: Underground Storage Tanks on Indian Land

The Indian Underground Storage Tank (UST) database provides information about underground storage tanks on Indian land in EPA Region 1 (Connecticut, Maine, Massachusetts, New Hampshire, Rhode Island, Vermont and ten Tribal Nations).

Date of Government Version: 04/29/2020	Source: EPA, Region 1
Date Data Arrived at EDR: 05/20/2020	Telephone: 617-918-1313
Date Made Active in Reports: 08/12/2020	Last EDR Contact: 07/24/2020
Number of Days to Update: 84	Next Scheduled EDR Contact: 11/02/2020
	Data Release Frequency: Varies

INDIAN UST R8: Underground Storage Tanks on Indian Land

The Indian Underground Storage Tank (UST) database provides information about underground storage tanks on Indian land in EPA Region 8 (Colorado, Montana, North Dakota, South Dakota, Utah, Wyoming and 27 Tribal Nations).

Date of Government Version: 04/14/2020	Source: EPA Region 8
Date Data Arrived at EDR: 05/20/2020	Telephone: 303-312-6137
Date Made Active in Reports: 08/13/2020	Last EDR Contact: 07/24/2020
Number of Days to Update: 85	Next Scheduled EDR Contact: 11/02/2020
	Data Release Frequency: Varies

State and tribal voluntary cleanup sites

VCP: Voluntary Cleanup Program Properties

Contains low threat level properties with either confirmed or unconfirmed releases and the project proponents have request that DTSC oversee investigation and/or cleanup activities and have agreed to provide coverage for DTSC's costs.

Date of Government Version: 04/27/2020	Source: Department of Toxic Substances Control
Date Data Arrived at EDR: 04/28/2020	Telephone: 916-323-3400
Date Made Active in Reports: 07/13/2020	Last EDR Contact: 07/27/2020
Number of Days to Update: 76	Next Scheduled EDR Contact: 11/09/2020
	Data Release Frequency: Quarterly

GOVERNMENT RECORDS SEARCHED / DATA CURRENCY TRACKING

INDIAN VCP R7: Voluntary Cleanup Priority Listing

A listing of voluntary cleanup priority sites located on Indian Land located in Region 7.

Date of Government Version: 03/20/2008	Source: EPA, Region 7
Date Data Arrived at EDR: 04/22/2008	Telephone: 913-551-7365
Date Made Active in Reports: 05/19/2008	Last EDR Contact: 04/20/2009
Number of Days to Update: 27	Next Scheduled EDR Contact: 07/20/2009
	Data Release Frequency: Varies

INDIAN VCP R1: Voluntary Cleanup Priority Listing

A listing of voluntary cleanup priority sites located on Indian Land located in Region 1.

Date of Government Version: 07/27/2015	Source: EPA, Region 1
Date Data Arrived at EDR: 09/29/2015	Telephone: 617-918-1102
Date Made Active in Reports: 02/18/2016	Last EDR Contact: 06/17/2020
Number of Days to Update: 142	Next Scheduled EDR Contact: 10/05/2020
	Data Release Frequency: Varies

State and tribal Brownfields sites

BROWNFIELDS: Considered Brownfields Sites Listing

A listing of sites the SWRCB considers to be Brownfields since these are sites have come to them through the MOA Process.

Date of Government Version: 03/23/2020	Source: State Water Resources Control Board
Date Data Arrived at EDR: 03/24/2020	Telephone: 916-323-7905
Date Made Active in Reports: 06/05/2020	Last EDR Contact: 06/22/2020
Number of Days to Update: 73	Next Scheduled EDR Contact: 10/05/2020
	Data Release Frequency: Quarterly

ADDITIONAL ENVIRONMENTAL RECORDS

Local Brownfield lists

US BROWNFIELDS: A Listing of Brownfields Sites

Brownfields are real property, the expansion, redevelopment, or reuse of which may be complicated by the presence or potential presence of a hazardous substance, pollutant, or contaminant. Cleaning up and reinvesting in these properties takes development pressures off of undeveloped, open land, and both improves and protects the environment. Assessment, Cleanup and Redevelopment Exchange System (ACRES) stores information reported by EPA Brownfields grant recipients on brownfields properties assessed or cleaned up with grant funding as well as information on Targeted Brownfields Assessments performed by EPA Regions. A listing of ACRES Brownfield sites is obtained from Cleanups in My Community. Cleanups in My Community provides information on Brownfields properties for which information is reported back to EPA, as well as areas served by Brownfields grant programs.

Date of Government Version: 06/01/2020	Source: Environmental Protection Agency
Date Data Arrived at EDR: 06/02/2020	Telephone: 202-566-2777
Date Made Active in Reports: 06/09/2020	Last EDR Contact: 06/02/2020
Number of Days to Update: 7	Next Scheduled EDR Contact: 09/28/2020
	Data Release Frequency: Semi-Annually

Local Lists of Landfill / Solid Waste Disposal Sites

WMUDS/SWAT: Waste Management Unit Database

Waste Management Unit Database System. WMUDS is used by the State Water Resources Control Board staff and the Regional Water Quality Control Boards for program tracking and inventory of waste management units. WMUDS is composed of the following databases: Facility Information, Scheduled Inspections Information, Waste Management Unit Information, SWAT Program Information, SWAT Report Summary Information, SWAT Report Summary Data, Chapter 15 (formerly Subchapter 15) Information, Chapter 15 Monitoring Parameters, TPCA Program Information, RCRA Program Information, Closure Information, and Interested Parties Information.

GOVERNMENT RECORDS SEARCHED / DATA CURRENCY TRACKING

Date of Government Version: 04/01/2000
Date Data Arrived at EDR: 04/10/2000
Date Made Active in Reports: 05/10/2000
Number of Days to Update: 30

Source: State Water Resources Control Board
Telephone: 916-227-4448
Last EDR Contact: 07/21/2020
Next Scheduled EDR Contact: 11/09/2020
Data Release Frequency: No Update Planned

SWRCY: Recycler Database

A listing of recycling facilities in California.

Date of Government Version: 06/08/2020
Date Data Arrived at EDR: 06/09/2020
Date Made Active in Reports: 08/19/2020
Number of Days to Update: 71

Source: Department of Conservation
Telephone: 916-323-3836
Last EDR Contact: 06/09/2020
Next Scheduled EDR Contact: 09/21/2020
Data Release Frequency: Quarterly

HAULERS: Registered Waste Tire Haulers Listing

A listing of registered waste tire haulers.

Date of Government Version: 05/28/2020
Date Data Arrived at EDR: 05/29/2020
Date Made Active in Reports: 08/12/2020
Number of Days to Update: 75

Source: Integrated Waste Management Board
Telephone: 916-341-6422
Last EDR Contact: 08/04/2020
Next Scheduled EDR Contact: 11/23/2020
Data Release Frequency: Varies

INDIAN ODI: Report on the Status of Open Dumps on Indian Lands

Location of open dumps on Indian land.

Date of Government Version: 12/31/1998
Date Data Arrived at EDR: 12/03/2007
Date Made Active in Reports: 01/24/2008
Number of Days to Update: 52

Source: Environmental Protection Agency
Telephone: 703-308-8245
Last EDR Contact: 07/21/2020
Next Scheduled EDR Contact: 11/09/2020
Data Release Frequency: Varies

ODI: Open Dump Inventory

An open dump is defined as a disposal facility that does not comply with one or more of the Part 257 or Part 258 Subtitle D Criteria.

Date of Government Version: 06/30/1985
Date Data Arrived at EDR: 08/09/2004
Date Made Active in Reports: 09/17/2004
Number of Days to Update: 39

Source: Environmental Protection Agency
Telephone: 800-424-9346
Last EDR Contact: 06/09/2004
Next Scheduled EDR Contact: N/A
Data Release Frequency: No Update Planned

DEBRIS REGION 9: Torres Martinez Reservation Illegal Dump Site Locations

A listing of illegal dump sites location on the Torres Martinez Indian Reservation located in eastern Riverside County and northern Imperial County, California.

Date of Government Version: 01/12/2009
Date Data Arrived at EDR: 05/07/2009
Date Made Active in Reports: 09/21/2009
Number of Days to Update: 137

Source: EPA, Region 9
Telephone: 415-947-4219
Last EDR Contact: 07/14/2020
Next Scheduled EDR Contact: 11/02/2020
Data Release Frequency: No Update Planned

IHS OPEN DUMPS: Open Dumps on Indian Land

A listing of all open dumps located on Indian Land in the United States.

Date of Government Version: 04/01/2014
Date Data Arrived at EDR: 08/06/2014
Date Made Active in Reports: 01/29/2015
Number of Days to Update: 176

Source: Department of Health & Human Services, Indian Health Service
Telephone: 301-443-1452
Last EDR Contact: 07/31/2020
Next Scheduled EDR Contact: 11/09/2020
Data Release Frequency: Varies

GOVERNMENT RECORDS SEARCHED / DATA CURRENCY TRACKING

Local Lists of Hazardous waste / Contaminated Sites

US HIST CDL: National Clandestine Laboratory Register

A listing of clandestine drug lab locations that have been removed from the DEAs National Clandestine Laboratory Register.

Date of Government Version: 03/18/2020	Source: Drug Enforcement Administration
Date Data Arrived at EDR: 03/19/2020	Telephone: 202-307-1000
Date Made Active in Reports: 06/09/2020	Last EDR Contact: 08/19/2020
Number of Days to Update: 82	Next Scheduled EDR Contact: 12/07/2020
	Data Release Frequency: No Update Planned

HIST CAL-SITES: Calsites Database

The Calsites database contains potential or confirmed hazardous substance release properties. In 1996, California EPA reevaluated and significantly reduced the number of sites in the Calsites database. No longer updated by the state agency. It has been replaced by ENVIROSTOR.

Date of Government Version: 08/08/2005	Source: Department of Toxic Substance Control
Date Data Arrived at EDR: 08/03/2006	Telephone: 916-323-3400
Date Made Active in Reports: 08/24/2006	Last EDR Contact: 02/23/2009
Number of Days to Update: 21	Next Scheduled EDR Contact: 05/25/2009
	Data Release Frequency: No Update Planned

SCH: School Property Evaluation Program

This category contains proposed and existing school sites that are being evaluated by DTSC for possible hazardous materials contamination. In some cases, these properties may be listed in the CalSites category depending on the level of threat to public health and safety or the environment they pose.

Date of Government Version: 04/27/2020	Source: Department of Toxic Substances Control
Date Data Arrived at EDR: 04/28/2020	Telephone: 916-323-3400
Date Made Active in Reports: 07/13/2020	Last EDR Contact: 07/27/2020
Number of Days to Update: 76	Next Scheduled EDR Contact: 11/09/2020
	Data Release Frequency: Quarterly

CDL: Clandestine Drug Labs

A listing of drug lab locations. Listing of a location in this database does not indicate that any illegal drug lab materials were or were not present there, and does not constitute a determination that the location either requires or does not require additional cleanup work.

Date of Government Version: 06/30/2019	Source: Department of Toxic Substances Control
Date Data Arrived at EDR: 05/28/2020	Telephone: 916-255-6504
Date Made Active in Reports: 08/12/2020	Last EDR Contact: 07/09/2020
Number of Days to Update: 76	Next Scheduled EDR Contact: 10/19/2020
	Data Release Frequency: Varies

TOXIC PITS: Toxic Pits Cleanup Act Sites

Toxic PITS Cleanup Act Sites. TOXIC PITS identifies sites suspected of containing hazardous substances where cleanup has not yet been completed.

Date of Government Version: 07/01/1995	Source: State Water Resources Control Board
Date Data Arrived at EDR: 08/30/1995	Telephone: 916-227-4364
Date Made Active in Reports: 09/26/1995	Last EDR Contact: 01/26/2009
Number of Days to Update: 27	Next Scheduled EDR Contact: 04/27/2009
	Data Release Frequency: No Update Planned

CERS HAZ WASTE: CERS HAZ WASTE

List of sites in the California Environmental Protection Agency (CalEPA) Regulated Site Portal which fall under the Hazardous Chemical Management, Hazardous Waste Onsite Treatment, Household Hazardous Waste Collection, Hazardous Waste Generator, and RCRA LQ HW Generator programs.

GOVERNMENT RECORDS SEARCHED / DATA CURRENCY TRACKING

Date of Government Version: 04/20/2020
Date Data Arrived at EDR: 04/21/2020
Date Made Active in Reports: 07/13/2020
Number of Days to Update: 83

Source: CalEPA
Telephone: 916-323-2514
Last EDR Contact: 07/21/2020
Next Scheduled EDR Contact: 11/02/2020
Data Release Frequency: Quarterly

US CDL: Clandestine Drug Labs

A listing of clandestine drug lab locations. The U.S. Department of Justice ("the Department") provides this web site as a public service. It contains addresses of some locations where law enforcement agencies reported they found chemicals or other items that indicated the presence of either clandestine drug laboratories or dumpsites. In most cases, the source of the entries is not the Department, and the Department has not verified the entry and does not guarantee its accuracy. Members of the public must verify the accuracy of all entries by, for example, contacting local law enforcement and local health departments.

Date of Government Version: 03/18/2020
Date Data Arrived at EDR: 03/19/2020
Date Made Active in Reports: 06/09/2020
Number of Days to Update: 82

Source: Drug Enforcement Administration
Telephone: 202-307-1000
Last EDR Contact: 08/19/2020
Next Scheduled EDR Contact: 12/07/2020
Data Release Frequency: Quarterly

PFAS: PFAS Contamination Site Location Listing

A listing of PFAS contaminated sites included in the GeoTracker database.

Date of Government Version: 06/08/2020
Date Data Arrived at EDR: 06/09/2020
Date Made Active in Reports: 08/19/2020
Number of Days to Update: 71

Source: State Water Resources Control Board
Telephone: 866-480-1028
Last EDR Contact: 06/09/2020
Next Scheduled EDR Contact: 09/21/2020
Data Release Frequency: Varies

Local Lists of Registered Storage Tanks

SWEEPS UST: SWEEPS UST Listing

Statewide Environmental Evaluation and Planning System. This underground storage tank listing was updated and maintained by a company contacted by the SWRCB in the early 1990's. The listing is no longer updated or maintained. The local agency is the contact for more information on a site on the SWEEPS list.

Date of Government Version: 06/01/1994
Date Data Arrived at EDR: 07/07/2005
Date Made Active in Reports: 08/11/2005
Number of Days to Update: 35

Source: State Water Resources Control Board
Telephone: N/A
Last EDR Contact: 06/03/2005
Next Scheduled EDR Contact: N/A
Data Release Frequency: No Update Planned

UST MENDOCINO: Mendocino County UST Database

A listing of underground storage tank locations in Mendocino County.

Date of Government Version: 05/20/2020
Date Data Arrived at EDR: 05/20/2020
Date Made Active in Reports: 08/06/2020
Number of Days to Update: 78

Source: Department of Public Health
Telephone: 707-463-4466
Last EDR Contact: 08/17/2020
Next Scheduled EDR Contact: 12/07/2020
Data Release Frequency: Annually

HIST UST: Hazardous Substance Storage Container Database

The Hazardous Substance Storage Container Database is a historical listing of UST sites. Refer to local/county source for current data.

Date of Government Version: 10/15/1990
Date Data Arrived at EDR: 01/25/1991
Date Made Active in Reports: 02/12/1991
Number of Days to Update: 18

Source: State Water Resources Control Board
Telephone: 916-341-5851
Last EDR Contact: 07/26/2001
Next Scheduled EDR Contact: N/A
Data Release Frequency: No Update Planned

GOVERNMENT RECORDS SEARCHED / DATA CURRENCY TRACKING

SAN FRANCISCO AST: Aboveground Storage Tank Site Listing Aboveground storage tank sites

Date of Government Version: 05/04/2020	Source: San Francisco County Department of Public Health
Date Data Arrived at EDR: 05/06/2020	Telephone: 415-252-3896
Date Made Active in Reports: 07/17/2020	Last EDR Contact: 07/28/2020
Number of Days to Update: 72	Next Scheduled EDR Contact: 11/16/2020
	Data Release Frequency: Varies

CA FID UST: Facility Inventory Database

The Facility Inventory Database (FID) contains a historical listing of active and inactive underground storage tank locations from the State Water Resource Control Board. Refer to local/county source for current data.

Date of Government Version: 10/31/1994	Source: California Environmental Protection Agency
Date Data Arrived at EDR: 09/05/1995	Telephone: 916-341-5851
Date Made Active in Reports: 09/29/1995	Last EDR Contact: 12/28/1998
Number of Days to Update: 24	Next Scheduled EDR Contact: N/A
	Data Release Frequency: No Update Planned

CERS TANKS: California Environmental Reporting System (CERS) Tanks

List of sites in the California Environmental Protection Agency (CalEPA) Regulated Site Portal which fall under the Aboveground Petroleum Storage and Underground Storage Tank regulatory programs.

Date of Government Version: 04/20/2020	Source: California Environmental Protection Agency
Date Data Arrived at EDR: 04/21/2020	Telephone: 916-323-2514
Date Made Active in Reports: 07/09/2020	Last EDR Contact: 07/21/2020
Number of Days to Update: 79	Next Scheduled EDR Contact: 11/02/2020
	Data Release Frequency: Quarterly

Local Land Records

LIENS: Environmental Liens Listing

A listing of property locations with environmental liens for California where DTSC is a lien holder.

Date of Government Version: 05/28/2020	Source: Department of Toxic Substances Control
Date Data Arrived at EDR: 05/29/2020	Telephone: 916-323-3400
Date Made Active in Reports: 08/12/2020	Last EDR Contact: 08/25/2020
Number of Days to Update: 75	Next Scheduled EDR Contact: 12/14/2020
	Data Release Frequency: Varies

LIENS 2: CERCLA Lien Information

A Federal CERCLA ('Superfund') lien can exist by operation of law at any site or property at which EPA has spent Superfund monies. These monies are spent to investigate and address releases and threatened releases of contamination. CERCLIS provides information as to the identity of these sites and properties.

Date of Government Version: 07/29/2020	Source: Environmental Protection Agency
Date Data Arrived at EDR: 08/03/2020	Telephone: 202-564-6023
Date Made Active in Reports: 08/25/2020	Last EDR Contact: 08/03/2020
Number of Days to Update: 22	Next Scheduled EDR Contact: 10/12/2020
	Data Release Frequency: Semi-Annually

DEED: Deed Restriction Listing

GOVERNMENT RECORDS SEARCHED / DATA CURRENCY TRACKING

Site Mitigation and Brownfields Reuse Program Facility Sites with Deed Restrictions & Hazardous Waste Management Program Facility Sites with Deed / Land Use Restriction. The DTSC Site Mitigation and Brownfields Reuse Program (SMBRP) list includes sites cleaned up under the program's oversight and generally does not include current or former hazardous waste facilities that required a hazardous waste facility permit. The list represents deed restrictions that are active. Some sites have multiple deed restrictions. The DTSC Hazardous Waste Management Program (HWMP) has developed a list of current or former hazardous waste facilities that have a recorded land use restriction at the local county recorder's office. The land use restrictions on this list were required by the DTSC HWMP as a result of the presence of hazardous substances that remain on site after the facility (or part of the facility) has been closed or cleaned up. The types of land use restriction include deed notice, deed restriction, or a land use restriction that binds current and future owners.

Date of Government Version: 06/01/2020	Source: DTSC and SWRCB
Date Data Arrived at EDR: 06/02/2020	Telephone: 916-323-3400
Date Made Active in Reports: 08/14/2020	Last EDR Contact: 06/02/2020
Number of Days to Update: 73	Next Scheduled EDR Contact: 09/14/2020
	Data Release Frequency: Semi-Annually

Records of Emergency Release Reports

HMIRS: Hazardous Materials Information Reporting System

Hazardous Materials Incident Report System. HMIRS contains hazardous material spill incidents reported to DOT.

Date of Government Version: 02/27/2020	Source: U.S. Department of Transportation
Date Data Arrived at EDR: 03/24/2020	Telephone: 202-366-4555
Date Made Active in Reports: 06/18/2020	Last EDR Contact: 06/23/2020
Number of Days to Update: 86	Next Scheduled EDR Contact: 10/05/2020
	Data Release Frequency: Quarterly

CHMIRS: California Hazardous Material Incident Report System

California Hazardous Material Incident Reporting System. CHMIRS contains information on reported hazardous material incidents (accidental releases or spills).

Date of Government Version: 03/31/2020	Source: Office of Emergency Services
Date Data Arrived at EDR: 04/21/2020	Telephone: 916-845-8400
Date Made Active in Reports: 07/09/2020	Last EDR Contact: 07/21/2020
Number of Days to Update: 79	Next Scheduled EDR Contact: 11/02/2020
	Data Release Frequency: Semi-Annually

LDS: Land Disposal Sites Listing (GEOTRACKER)

Land Disposal sites (Landfills) included in GeoTracker. GeoTracker is the Water Boards data management system for sites that impact, or have the potential to impact, water quality in California, with emphasis on groundwater.

Date of Government Version: 06/08/2020	Source: State Water Quality Control Board
Date Data Arrived at EDR: 06/09/2020	Telephone: 866-480-1028
Date Made Active in Reports: 08/19/2020	Last EDR Contact: 06/09/2020
Number of Days to Update: 71	Next Scheduled EDR Contact: 09/21/2020
	Data Release Frequency: Quarterly

MCS: Military Cleanup Sites Listing (GEOTRACKER)

Military sites (consisting of: Military UST sites; Military Privatized sites; and Military Cleanup sites [formerly known as DoD non UST]) included in GeoTracker. GeoTracker is the Water Boards data management system for sites that impact, or have the potential to impact, water quality in California, with emphasis on groundwater.

Date of Government Version: 06/08/2020	Source: State Water Resources Control Board
Date Data Arrived at EDR: 06/09/2020	Telephone: 866-480-1028
Date Made Active in Reports: 08/19/2020	Last EDR Contact: 06/09/2020
Number of Days to Update: 71	Next Scheduled EDR Contact: 09/21/2020
	Data Release Frequency: Quarterly

GOVERNMENT RECORDS SEARCHED / DATA CURRENCY TRACKING

SPILLS 90: SPILLS90 data from FirstSearch

Spills 90 includes those spill and release records available exclusively from FirstSearch databases. Typically, they may include chemical, oil and/or hazardous substance spills recorded after 1990. Duplicate records that are already included in EDR incident and release records are not included in Spills 90.

Date of Government Version: 06/06/2012	Source: FirstSearch
Date Data Arrived at EDR: 01/03/2013	Telephone: N/A
Date Made Active in Reports: 02/22/2013	Last EDR Contact: 01/03/2013
Number of Days to Update: 50	Next Scheduled EDR Contact: N/A
	Data Release Frequency: No Update Planned

Other Ascertainable Records

RCRA NonGen / NLR: RCRA - Non Generators / No Longer Regulated

RCRAInfo is EPA's comprehensive information system, providing access to data supporting the Resource Conservation and Recovery Act (RCRA) of 1976 and the Hazardous and Solid Waste Amendments (HSWA) of 1984. The database includes selective information on sites which generate, transport, store, treat and/or dispose of hazardous waste as defined by the Resource Conservation and Recovery Act (RCRA). Non-Generators do not presently generate hazardous waste.

Date of Government Version: 03/23/2020	Source: Environmental Protection Agency
Date Data Arrived at EDR: 03/25/2020	Telephone: (415) 495-8895
Date Made Active in Reports: 05/21/2020	Last EDR Contact: 06/22/2020
Number of Days to Update: 57	Next Scheduled EDR Contact: 10/05/2020
	Data Release Frequency: Quarterly

FUDS: Formerly Used Defense Sites

The listing includes locations of Formerly Used Defense Sites properties where the US Army Corps of Engineers is actively working or will take necessary cleanup actions.

Date of Government Version: 05/13/2020	Source: U.S. Army Corps of Engineers
Date Data Arrived at EDR: 05/18/2020	Telephone: 202-528-4285
Date Made Active in Reports: 08/12/2020	Last EDR Contact: 08/13/2020
Number of Days to Update: 86	Next Scheduled EDR Contact: 11/30/2020
	Data Release Frequency: Varies

DOD: Department of Defense Sites

This data set consists of federally owned or administered lands, administered by the Department of Defense, that have any area equal to or greater than 640 acres of the United States, Puerto Rico, and the U.S. Virgin Islands.

Date of Government Version: 12/31/2005	Source: USGS
Date Data Arrived at EDR: 11/10/2006	Telephone: 888-275-8747
Date Made Active in Reports: 01/11/2007	Last EDR Contact: 07/09/2020
Number of Days to Update: 62	Next Scheduled EDR Contact: 10/19/2020
	Data Release Frequency: Semi-Annually

FEDLAND: Federal and Indian Lands

Federally and Indian administrated lands of the United States. Lands included are administrated by: Army Corps of Engineers, Bureau of Reclamation, National Wild and Scenic River, National Wildlife Refuge, Public Domain Land, Wilderness, Wilderness Study Area, Wildlife Management Area, Bureau of Indian Affairs, Bureau of Land Management, Department of Justice, Forest Service, Fish and Wildlife Service, National Park Service.

Date of Government Version: 04/02/2018	Source: U.S. Geological Survey
Date Data Arrived at EDR: 04/11/2018	Telephone: 888-275-8747
Date Made Active in Reports: 11/06/2019	Last EDR Contact: 07/06/2020
Number of Days to Update: 574	Next Scheduled EDR Contact: 10/19/2020
	Data Release Frequency: N/A

SCRD DRYCLEANERS: State Coalition for Remediation of Drycleaners Listing

The State Coalition for Remediation of Drycleaners was established in 1998, with support from the U.S. EPA Office of Superfund Remediation and Technology Innovation. It is comprised of representatives of states with established drycleaner remediation programs. Currently the member states are Alabama, Connecticut, Florida, Illinois, Kansas, Minnesota, Missouri, North Carolina, Oregon, South Carolina, Tennessee, Texas, and Wisconsin.

GOVERNMENT RECORDS SEARCHED / DATA CURRENCY TRACKING

Date of Government Version: 01/01/2017
Date Data Arrived at EDR: 02/03/2017
Date Made Active in Reports: 04/07/2017
Number of Days to Update: 63

Source: Environmental Protection Agency
Telephone: 615-532-8599
Last EDR Contact: 08/05/2020
Next Scheduled EDR Contact: 11/23/2020
Data Release Frequency: Varies

US FIN ASSUR: Financial Assurance Information

All owners and operators of facilities that treat, store, or dispose of hazardous waste are required to provide proof that they will have sufficient funds to pay for the clean up, closure, and post-closure care of their facilities.

Date of Government Version: 03/23/2020
Date Data Arrived at EDR: 03/24/2020
Date Made Active in Reports: 06/18/2020
Number of Days to Update: 86

Source: Environmental Protection Agency
Telephone: 202-566-1917
Last EDR Contact: 06/22/2020
Next Scheduled EDR Contact: 10/05/2020
Data Release Frequency: Quarterly

EPA WATCH LIST: EPA WATCH LIST

EPA maintains a "Watch List" to facilitate dialogue between EPA, state and local environmental agencies on enforcement matters relating to facilities with alleged violations identified as either significant or high priority. Being on the Watch List does not mean that the facility has actually violated the law only that an investigation by EPA or a state or local environmental agency has led those organizations to allege that an unproven violation has in fact occurred. Being on the Watch List does not represent a higher level of concern regarding the alleged violations that were detected, but instead indicates cases requiring additional dialogue between EPA, state and local agencies - primarily because of the length of time the alleged violation has gone unaddressed or unresolved.

Date of Government Version: 08/30/2013
Date Data Arrived at EDR: 03/21/2014
Date Made Active in Reports: 06/17/2014
Number of Days to Update: 88

Source: Environmental Protection Agency
Telephone: 617-520-3000
Last EDR Contact: 07/31/2020
Next Scheduled EDR Contact: 11/16/2020
Data Release Frequency: Quarterly

2020 COR ACTION: 2020 Corrective Action Program List

The EPA has set ambitious goals for the RCRA Corrective Action program by creating the 2020 Corrective Action Universe. This RCRA cleanup baseline includes facilities expected to need corrective action. The 2020 universe contains a wide variety of sites. Some properties are heavily contaminated while others were contaminated but have since been cleaned up. Still others have not been fully investigated yet, and may require little or no remediation. Inclusion in the 2020 Universe does not necessarily imply failure on the part of a facility to meet its RCRA obligations.

Date of Government Version: 09/30/2017
Date Data Arrived at EDR: 05/08/2018
Date Made Active in Reports: 07/20/2018
Number of Days to Update: 73

Source: Environmental Protection Agency
Telephone: 703-308-4044
Last EDR Contact: 08/06/2020
Next Scheduled EDR Contact: 11/16/2020
Data Release Frequency: Varies

TSCA: Toxic Substances Control Act

Toxic Substances Control Act. TSCA identifies manufacturers and importers of chemical substances included on the TSCA Chemical Substance Inventory list. It includes data on the production volume of these substances by plant site.

Date of Government Version: 12/31/2016
Date Data Arrived at EDR: 06/21/2017
Date Made Active in Reports: 01/05/2018
Number of Days to Update: 198

Source: EPA
Telephone: 202-260-5521
Last EDR Contact: 06/17/2020
Next Scheduled EDR Contact: 09/28/2020
Data Release Frequency: Every 4 Years

TRIS: Toxic Chemical Release Inventory System

Toxic Release Inventory System. TRIS identifies facilities which release toxic chemicals to the air, water and land in reportable quantities under SARA Title III Section 313.

GOVERNMENT RECORDS SEARCHED / DATA CURRENCY TRACKING

Date of Government Version: 12/31/2018
Date Data Arrived at EDR: 02/05/2020
Date Made Active in Reports: 04/24/2020
Number of Days to Update: 79

Source: EPA
Telephone: 202-566-0250
Last EDR Contact: 08/14/2020
Next Scheduled EDR Contact: 11/30/2020
Data Release Frequency: Annually

SSTS: Section 7 Tracking Systems

Section 7 of the Federal Insecticide, Fungicide and Rodenticide Act, as amended (92 Stat. 829) requires all registered pesticide-producing establishments to submit a report to the Environmental Protection Agency by March 1st each year. Each establishment must report the types and amounts of pesticides, active ingredients and devices being produced, and those having been produced and sold or distributed in the past year.

Date of Government Version: 03/01/2020
Date Data Arrived at EDR: 04/21/2020
Date Made Active in Reports: 07/15/2020
Number of Days to Update: 85

Source: EPA
Telephone: 202-564-4203
Last EDR Contact: 07/21/2020
Next Scheduled EDR Contact: 11/02/2020
Data Release Frequency: Annually

ROD: Records Of Decision

Record of Decision. ROD documents mandate a permanent remedy at an NPL (Superfund) site containing technical and health information to aid in the cleanup.

Date of Government Version: 07/29/2020
Date Data Arrived at EDR: 08/03/2020
Date Made Active in Reports: 08/25/2020
Number of Days to Update: 22

Source: EPA
Telephone: 703-416-0223
Last EDR Contact: 08/03/2020
Next Scheduled EDR Contact: 09/14/2020
Data Release Frequency: Annually

RMP: Risk Management Plans

When Congress passed the Clean Air Act Amendments of 1990, it required EPA to publish regulations and guidance for chemical accident prevention at facilities using extremely hazardous substances. The Risk Management Program Rule (RMP Rule) was written to implement Section 112(r) of these amendments. The rule, which built upon existing industry codes and standards, requires companies of all sizes that use certain flammable and toxic substances to develop a Risk Management Program, which includes a(n): Hazard assessment that details the potential effects of an accidental release, an accident history of the last five years, and an evaluation of worst-case and alternative accidental releases; Prevention program that includes safety precautions and maintenance, monitoring, and employee training measures; and Emergency response program that spells out emergency health care, employee training measures and procedures for informing the public and response agencies (e.g the fire department) should an accident occur.

Date of Government Version: 01/31/2020
Date Data Arrived at EDR: 05/13/2020
Date Made Active in Reports: 08/03/2020
Number of Days to Update: 82

Source: Environmental Protection Agency
Telephone: 202-564-8600
Last EDR Contact: 07/15/2020
Next Scheduled EDR Contact: 11/02/2020
Data Release Frequency: Varies

RAATS: RCRA Administrative Action Tracking System

RCRA Administration Action Tracking System. RAATS contains records based on enforcement actions issued under RCRA pertaining to major violators and includes administrative and civil actions brought by the EPA. For administration actions after September 30, 1995, data entry in the RAATS database was discontinued. EPA will retain a copy of the database for historical records. It was necessary to terminate RAATS because a decrease in agency resources made it impossible to continue to update the information contained in the database.

Date of Government Version: 04/17/1995
Date Data Arrived at EDR: 07/03/1995
Date Made Active in Reports: 08/07/1995
Number of Days to Update: 35

Source: EPA
Telephone: 202-564-4104
Last EDR Contact: 06/02/2008
Next Scheduled EDR Contact: 09/01/2008
Data Release Frequency: No Update Planned

GOVERNMENT RECORDS SEARCHED / DATA CURRENCY TRACKING

PRP: Potentially Responsible Parties

A listing of verified Potentially Responsible Parties

Date of Government Version: 04/27/2020	Source: EPA
Date Data Arrived at EDR: 05/06/2020	Telephone: 202-564-6023
Date Made Active in Reports: 06/09/2020	Last EDR Contact: 08/03/2020
Number of Days to Update: 34	Next Scheduled EDR Contact: 11/16/2020
	Data Release Frequency: Quarterly

PADS: PCB Activity Database System

PCB Activity Database. PADS Identifies generators, transporters, commercial storers and/or brokers and disposers of PCB's who are required to notify the EPA of such activities.

Date of Government Version: 10/09/2019	Source: EPA
Date Data Arrived at EDR: 10/11/2019	Telephone: 202-566-0500
Date Made Active in Reports: 12/20/2019	Last EDR Contact: 07/13/2020
Number of Days to Update: 70	Next Scheduled EDR Contact: 10/19/2020
	Data Release Frequency: Annually

ICIS: Integrated Compliance Information System

The Integrated Compliance Information System (ICIS) supports the information needs of the national enforcement and compliance program as well as the unique needs of the National Pollutant Discharge Elimination System (NPDES) program.

Date of Government Version: 11/18/2016	Source: Environmental Protection Agency
Date Data Arrived at EDR: 11/23/2016	Telephone: 202-564-2501
Date Made Active in Reports: 02/10/2017	Last EDR Contact: 06/30/2020
Number of Days to Update: 79	Next Scheduled EDR Contact: 10/19/2020
	Data Release Frequency: Quarterly

FTTS: FIFRA/ TSCA Tracking System - FIFRA (Federal Insecticide, Fungicide, & Rodenticide Act)/TSCA (Toxic Substances Control Act)

FTTS tracks administrative cases and pesticide enforcement actions and compliance activities related to FIFRA, TSCA and EPCRA (Emergency Planning and Community Right-to-Know Act). To maintain currency, EDR contacts the Agency on a quarterly basis.

Date of Government Version: 04/09/2009	Source: EPA/Office of Prevention, Pesticides and Toxic Substances
Date Data Arrived at EDR: 04/16/2009	Telephone: 202-566-1667
Date Made Active in Reports: 05/11/2009	Last EDR Contact: 08/18/2017
Number of Days to Update: 25	Next Scheduled EDR Contact: 12/04/2017
	Data Release Frequency: No Update Planned

FTTS INSP: FIFRA/ TSCA Tracking System - FIFRA (Federal Insecticide, Fungicide, & Rodenticide Act)/TSCA (Toxic Substances Control Act)

A listing of FIFRA/TSCA Tracking System (FTTS) inspections and enforcements.

Date of Government Version: 04/09/2009	Source: EPA
Date Data Arrived at EDR: 04/16/2009	Telephone: 202-566-1667
Date Made Active in Reports: 05/11/2009	Last EDR Contact: 08/18/2017
Number of Days to Update: 25	Next Scheduled EDR Contact: 12/04/2017
	Data Release Frequency: No Update Planned

MLTS: Material Licensing Tracking System

MLTS is maintained by the Nuclear Regulatory Commission and contains a list of approximately 8,100 sites which possess or use radioactive materials and which are subject to NRC licensing requirements. To maintain currency, EDR contacts the Agency on a quarterly basis.

Date of Government Version: 10/25/2019	Source: Nuclear Regulatory Commission
Date Data Arrived at EDR: 10/25/2019	Telephone: 301-415-7169
Date Made Active in Reports: 01/15/2020	Last EDR Contact: 07/20/2020
Number of Days to Update: 82	Next Scheduled EDR Contact: 11/02/2020
	Data Release Frequency: Quarterly

GOVERNMENT RECORDS SEARCHED / DATA CURRENCY TRACKING

COAL ASH DOE: Steam-Electric Plant Operation Data

A listing of power plants that store ash in surface ponds.

Date of Government Version: 12/31/2018	Source: Department of Energy
Date Data Arrived at EDR: 12/04/2019	Telephone: 202-586-8719
Date Made Active in Reports: 01/15/2020	Last EDR Contact: 06/05/2020
Number of Days to Update: 42	Next Scheduled EDR Contact: 09/14/2020
	Data Release Frequency: Varies

COAL ASH EPA: Coal Combustion Residues Surface Impoundments List

A listing of coal combustion residues surface impoundments with high hazard potential ratings.

Date of Government Version: 01/12/2017	Source: Environmental Protection Agency
Date Data Arrived at EDR: 03/05/2019	Telephone: N/A
Date Made Active in Reports: 11/11/2019	Last EDR Contact: 06/01/2020
Number of Days to Update: 251	Next Scheduled EDR Contact: 09/14/2020
	Data Release Frequency: Varies

PCB TRANSFORMER: PCB Transformer Registration Database

The database of PCB transformer registrations that includes all PCB registration submittals.

Date of Government Version: 09/13/2019	Source: Environmental Protection Agency
Date Data Arrived at EDR: 11/06/2019	Telephone: 202-566-0517
Date Made Active in Reports: 02/10/2020	Last EDR Contact: 08/06/2020
Number of Days to Update: 96	Next Scheduled EDR Contact: 11/16/2020
	Data Release Frequency: Varies

RADINFO: Radiation Information Database

The Radiation Information Database (RADINFO) contains information about facilities that are regulated by U.S. Environmental Protection Agency (EPA) regulations for radiation and radioactivity.

Date of Government Version: 07/01/2019	Source: Environmental Protection Agency
Date Data Arrived at EDR: 07/01/2019	Telephone: 202-343-9775
Date Made Active in Reports: 09/23/2019	Last EDR Contact: 06/24/2020
Number of Days to Update: 84	Next Scheduled EDR Contact: 10/12/2020
	Data Release Frequency: Quarterly

HIST FTTS: FIFRA/TSCA Tracking System Administrative Case Listing

A complete administrative case listing from the FIFRA/TSCA Tracking System (FTTS) for all ten EPA regions. The information was obtained from the National Compliance Database (NCDB). NCDB supports the implementation of FIFRA (Federal Insecticide, Fungicide, and Rodenticide Act) and TSCA (Toxic Substances Control Act). Some EPA regions are now closing out records. Because of that, and the fact that some EPA regions are not providing EPA Headquarters with updated records, it was decided to create a HIST FTTS database. It included records that may not be included in the newer FTTS database updates. This database is no longer updated.

Date of Government Version: 10/19/2006	Source: Environmental Protection Agency
Date Data Arrived at EDR: 03/01/2007	Telephone: 202-564-2501
Date Made Active in Reports: 04/10/2007	Last EDR Contact: 12/17/2007
Number of Days to Update: 40	Next Scheduled EDR Contact: 03/17/2008
	Data Release Frequency: No Update Planned

HIST FTTS INSP: FIFRA/TSCA Tracking System Inspection & Enforcement Case Listing

A complete inspection and enforcement case listing from the FIFRA/TSCA Tracking System (FTTS) for all ten EPA regions. The information was obtained from the National Compliance Database (NCDB). NCDB supports the implementation of FIFRA (Federal Insecticide, Fungicide, and Rodenticide Act) and TSCA (Toxic Substances Control Act). Some EPA regions are now closing out records. Because of that, and the fact that some EPA regions are not providing EPA Headquarters with updated records, it was decided to create a HIST FTTS database. It included records that may not be included in the newer FTTS database updates. This database is no longer updated.

GOVERNMENT RECORDS SEARCHED / DATA CURRENCY TRACKING

Date of Government Version: 10/19/2006
Date Data Arrived at EDR: 03/01/2007
Date Made Active in Reports: 04/10/2007
Number of Days to Update: 40

Source: Environmental Protection Agency
Telephone: 202-564-2501
Last EDR Contact: 12/17/2008
Next Scheduled EDR Contact: 03/17/2008
Data Release Frequency: No Update Planned

DOT OPS: Incident and Accident Data

Department of Transportation, Office of Pipeline Safety Incident and Accident data.

Date of Government Version: 01/02/2020
Date Data Arrived at EDR: 01/28/2020
Date Made Active in Reports: 04/17/2020
Number of Days to Update: 80

Source: Department of Transportation, Office of Pipeline Safety
Telephone: 202-366-4595
Last EDR Contact: 07/27/2020
Next Scheduled EDR Contact: 11/09/2020
Data Release Frequency: Quarterly

CONSENT: Superfund (CERCLA) Consent Decrees

Major legal settlements that establish responsibility and standards for cleanup at NPL (Superfund) sites. Released periodically by United States District Courts after settlement by parties to litigation matters.

Date of Government Version: 06/30/2020
Date Data Arrived at EDR: 07/15/2020
Date Made Active in Reports: 07/21/2020
Number of Days to Update: 6

Source: Department of Justice, Consent Decree Library
Telephone: Varies
Last EDR Contact: 07/06/2020
Next Scheduled EDR Contact: 10/19/2020
Data Release Frequency: Varies

BRS: Biennial Reporting System

The Biennial Reporting System is a national system administered by the EPA that collects data on the generation and management of hazardous waste. BRS captures detailed data from two groups: Large Quantity Generators (LQG) and Treatment, Storage, and Disposal Facilities.

Date of Government Version: 12/31/2015
Date Data Arrived at EDR: 02/22/2017
Date Made Active in Reports: 09/28/2017
Number of Days to Update: 218

Source: EPA/NTIS
Telephone: 800-424-9346
Last EDR Contact: 06/22/2020
Next Scheduled EDR Contact: 10/05/2020
Data Release Frequency: Biennially

INDIAN RESERV: Indian Reservations

This map layer portrays Indian administered lands of the United States that have any area equal to or greater than 640 acres.

Date of Government Version: 12/31/2014
Date Data Arrived at EDR: 07/14/2015
Date Made Active in Reports: 01/10/2017
Number of Days to Update: 546

Source: USGS
Telephone: 202-208-3710
Last EDR Contact: 07/07/2020
Next Scheduled EDR Contact: 10/19/2020
Data Release Frequency: Semi-Annually

FUSRAP: Formerly Utilized Sites Remedial Action Program

DOE established the Formerly Utilized Sites Remedial Action Program (FUSRAP) in 1974 to remediate sites where radioactive contamination remained from Manhattan Project and early U.S. Atomic Energy Commission (AEC) operations.

Date of Government Version: 08/08/2017
Date Data Arrived at EDR: 09/11/2018
Date Made Active in Reports: 09/14/2018
Number of Days to Update: 3

Source: Department of Energy
Telephone: 202-586-3559
Last EDR Contact: 07/28/2020
Next Scheduled EDR Contact: 11/16/2020
Data Release Frequency: Varies

UMTRA: Uranium Mill Tailings Sites

Uranium ore was mined by private companies for federal government use in national defense programs. When the mills shut down, large piles of the sand-like material (mill tailings) remain after uranium has been extracted from the ore. Levels of human exposure to radioactive materials from the piles are low; however, in some cases tailings were used as construction materials before the potential health hazards of the tailings were recognized.

GOVERNMENT RECORDS SEARCHED / DATA CURRENCY TRACKING

Date of Government Version: 08/30/2019
Date Data Arrived at EDR: 11/15/2019
Date Made Active in Reports: 01/28/2020
Number of Days to Update: 74

Source: Department of Energy
Telephone: 505-845-0011
Last EDR Contact: 08/21/2020
Next Scheduled EDR Contact: 11/30/2020
Data Release Frequency: Varies

LEAD SMELTER 1: Lead Smelter Sites

A listing of former lead smelter site locations.

Date of Government Version: 07/29/2020
Date Data Arrived at EDR: 08/03/2020
Date Made Active in Reports: 08/25/2020
Number of Days to Update: 22

Source: Environmental Protection Agency
Telephone: 703-603-8787
Last EDR Contact: 08/03/2020
Next Scheduled EDR Contact: 10/12/2020
Data Release Frequency: Varies

LEAD SMELTER 2: Lead Smelter Sites

A list of several hundred sites in the U.S. where secondary lead smelting was done from 1931 and 1964. These sites may pose a threat to public health through ingestion or inhalation of contaminated soil or dust

Date of Government Version: 04/05/2001
Date Data Arrived at EDR: 10/27/2010
Date Made Active in Reports: 12/02/2010
Number of Days to Update: 36

Source: American Journal of Public Health
Telephone: 703-305-6451
Last EDR Contact: 12/02/2009
Next Scheduled EDR Contact: N/A
Data Release Frequency: No Update Planned

US AIRS (AFS): Aerometric Information Retrieval System Facility Subsystem (AFS)

The database is a sub-system of Aerometric Information Retrieval System (AIRS). AFS contains compliance data on air pollution point sources regulated by the U.S. EPA and/or state and local air regulatory agencies. This information comes from source reports by various stationary sources of air pollution, such as electric power plants, steel mills, factories, and universities, and provides information about the air pollutants they produce. Action, air program, air program pollutant, and general level plant data. It is used to track emissions and compliance data from industrial plants.

Date of Government Version: 10/12/2016
Date Data Arrived at EDR: 10/26/2016
Date Made Active in Reports: 02/03/2017
Number of Days to Update: 100

Source: EPA
Telephone: 202-564-2496
Last EDR Contact: 09/26/2017
Next Scheduled EDR Contact: 01/08/2018
Data Release Frequency: Annually

US AIRS MINOR: Air Facility System Data

A listing of minor source facilities.

Date of Government Version: 10/12/2016
Date Data Arrived at EDR: 10/26/2016
Date Made Active in Reports: 02/03/2017
Number of Days to Update: 100

Source: EPA
Telephone: 202-564-2496
Last EDR Contact: 09/26/2017
Next Scheduled EDR Contact: 01/08/2018
Data Release Frequency: Annually

US MINES: Mines Master Index File

Contains all mine identification numbers issued for mines active or opened since 1971. The data also includes violation information.

Date of Government Version: 05/01/2020
Date Data Arrived at EDR: 05/21/2020
Date Made Active in Reports: 08/13/2020
Number of Days to Update: 84

Source: Department of Labor, Mine Safety and Health Administration
Telephone: 303-231-5959
Last EDR Contact: 08/25/2020
Next Scheduled EDR Contact: 12/07/2020
Data Release Frequency: Semi-Annually

MINES VIOLATIONS: MSHA Violation Assessment Data

Mines violation and assessment information. Department of Labor, Mine Safety & Health Administration.

GOVERNMENT RECORDS SEARCHED / DATA CURRENCY TRACKING

Date of Government Version: 05/28/2020
Date Data Arrived at EDR: 05/28/2020
Date Made Active in Reports: 08/13/2020
Number of Days to Update: 77

Source: DOL, Mine Safety & Health Admi
Telephone: 202-693-9424
Last EDR Contact: 08/26/2020
Next Scheduled EDR Contact: 12/14/2020
Data Release Frequency: Quarterly

US MINES 2: Ferrous and Nonferrous Metal Mines Database Listing

This map layer includes ferrous (ferrous metal mines are facilities that extract ferrous metals, such as iron ore or molybdenum) and nonferrous (Nonferrous metal mines are facilities that extract nonferrous metals, such as gold, silver, copper, zinc, and lead) metal mines in the United States.

Date of Government Version: 05/06/2020
Date Data Arrived at EDR: 05/27/2020
Date Made Active in Reports: 08/13/2020
Number of Days to Update: 78

Source: USGS
Telephone: 703-648-7709
Last EDR Contact: 05/27/2020
Next Scheduled EDR Contact: 09/07/2020
Data Release Frequency: Varies

US MINES 3: Active Mines & Mineral Plants Database Listing

Active Mines and Mineral Processing Plant operations for commodities monitored by the Minerals Information Team of the USGS.

Date of Government Version: 04/14/2011
Date Data Arrived at EDR: 06/08/2011
Date Made Active in Reports: 09/13/2011
Number of Days to Update: 97

Source: USGS
Telephone: 703-648-7709
Last EDR Contact: 05/21/2020
Next Scheduled EDR Contact: 09/07/2020
Data Release Frequency: Varies

ABANDONED MINES: Abandoned Mines

An inventory of land and water impacted by past mining (primarily coal mining) is maintained by OSMRE to provide information needed to implement the Surface Mining Control and Reclamation Act of 1977 (SMCRA). The inventory contains information on the location, type, and extent of AML impacts, as well as, information on the cost associated with the reclamation of those problems. The inventory is based upon field surveys by State, Tribal, and OSMRE program officials. It is dynamic to the extent that it is modified as new problems are identified and existing problems are reclaimed.

Date of Government Version: 03/05/2020
Date Data Arrived at EDR: 03/06/2020
Date Made Active in Reports: 05/29/2020
Number of Days to Update: 84

Source: Department of Interior
Telephone: 202-208-2609
Last EDR Contact: 06/19/2020
Next Scheduled EDR Contact: 09/21/2020
Data Release Frequency: Quarterly

FINDS: Facility Index System/Facility Registry System

Facility Index System. FINDS contains both facility information and 'pointers' to other sources that contain more detail. EDR includes the following FINDS databases in this report: PCS (Permit Compliance System), AIRS (Aerometric Information Retrieval System), DOCKET (Enforcement Docket used to manage and track information on civil judicial enforcement cases for all environmental statutes), FURS (Federal Underground Injection Control), C-DOCKET (Criminal Docket System used to track criminal enforcement actions for all environmental statutes), FFIS (Federal Facilities Information System), STATE (State Environmental Laws and Statutes), and PADS (PCB Activity Data System).

Date of Government Version: 02/03/2020
Date Data Arrived at EDR: 03/03/2020
Date Made Active in Reports: 05/28/2020
Number of Days to Update: 86

Source: EPA
Telephone: (415) 947-8000
Last EDR Contact: 08/26/2020
Next Scheduled EDR Contact: 12/14/2020
Data Release Frequency: Quarterly

UXO: Unexploded Ordnance Sites

A listing of unexploded ordnance site locations

Date of Government Version: 12/31/2017
Date Data Arrived at EDR: 01/17/2019
Date Made Active in Reports: 04/01/2019
Number of Days to Update: 74

Source: Department of Defense
Telephone: 703-704-1564
Last EDR Contact: 07/09/2020
Next Scheduled EDR Contact: 10/26/2020
Data Release Frequency: Varies

GOVERNMENT RECORDS SEARCHED / DATA CURRENCY TRACKING

ECHO: Enforcement & Compliance History Information

ECHO provides integrated compliance and enforcement information for about 800,000 regulated facilities nationwide.

Date of Government Version: 04/04/2020	Source: Environmental Protection Agency
Date Data Arrived at EDR: 04/07/2020	Telephone: 202-564-2280
Date Made Active in Reports: 06/26/2020	Last EDR Contact: 07/02/2020
Number of Days to Update: 80	Next Scheduled EDR Contact: 10/19/2020
	Data Release Frequency: Quarterly

DOCKET HWC: Hazardous Waste Compliance Docket Listing

A complete list of the Federal Agency Hazardous Waste Compliance Docket Facilities.

Date of Government Version: 05/31/2018	Source: Environmental Protection Agency
Date Data Arrived at EDR: 07/26/2018	Telephone: 202-564-0527
Date Made Active in Reports: 10/05/2018	Last EDR Contact: 08/19/2020
Number of Days to Update: 71	Next Scheduled EDR Contact: 12/07/2020
	Data Release Frequency: Varies

FUELS PROGRAM: EPA Fuels Program Registered Listing

This listing includes facilities that are registered under the Part 80 (Code of Federal Regulations) EPA Fuels Programs. All companies now are required to submit new and updated registrations.

Date of Government Version: 05/18/2020	Source: EPA
Date Data Arrived at EDR: 05/19/2020	Telephone: 800-385-6164
Date Made Active in Reports: 08/03/2020	Last EDR Contact: 08/17/2020
Number of Days to Update: 76	Next Scheduled EDR Contact: 11/30/2020
	Data Release Frequency: Quarterly

CA BOND EXP. PLAN: Bond Expenditure Plan

Department of Health Services developed a site-specific expenditure plan as the basis for an appropriation of Hazardous Substance Cleanup Bond Act funds. It is not updated.

Date of Government Version: 01/01/1989	Source: Department of Health Services
Date Data Arrived at EDR: 07/27/1994	Telephone: 916-255-2118
Date Made Active in Reports: 08/02/1994	Last EDR Contact: 05/31/1994
Number of Days to Update: 6	Next Scheduled EDR Contact: N/A
	Data Release Frequency: No Update Planned

CORTESE: "Cortese" Hazardous Waste & Substances Sites List

The sites for the list are designated by the State Water Resource Control Board (LUST), the Integrated Waste Board (SWF/LS), and the Department of Toxic Substances Control (Cal-Sites).

Date of Government Version: 03/23/2020	Source: CAL EPA/Office of Emergency Information
Date Data Arrived at EDR: 03/24/2020	Telephone: 916-323-3400
Date Made Active in Reports: 06/05/2020	Last EDR Contact: 06/22/2020
Number of Days to Update: 73	Next Scheduled EDR Contact: 10/05/2020
	Data Release Frequency: Quarterly

CUPA LIVERMORE-PLEASANTON: CUPA Facility Listing

list of facilities associated with the various CUPA programs in Livermore-Pleasanton

Date of Government Version: 05/01/2019	Source: Livermore-Pleasanton Fire Department
Date Data Arrived at EDR: 05/14/2019	Telephone: 925-454-2361
Date Made Active in Reports: 07/17/2019	Last EDR Contact: 08/14/2020
Number of Days to Update: 64	Next Scheduled EDR Contact: 11/23/2020
	Data Release Frequency: Varies

CUPA SAN FRANCISCO CO: CUPA Facility Listing

Cupa facilities

GOVERNMENT RECORDS SEARCHED / DATA CURRENCY TRACKING

Date of Government Version: 05/04/2020
Date Data Arrived at EDR: 05/06/2020
Date Made Active in Reports: 07/17/2020
Number of Days to Update: 72

Source: San Francisco County Department of Environmental Health
Telephone: 415-252-3896
Last EDR Contact: 07/28/2020
Next Scheduled EDR Contact: 11/16/2020
Data Release Frequency: Varies

KERN CO CUPA: Hazardous Material Business Plan

A listing of sites included in the Kern County Hazardous Material Business Plan.

Date of Government Version: 04/29/2020
Date Data Arrived at EDR: 05/05/2020
Date Made Active in Reports: 08/26/2020
Number of Days to Update: 113

Source: Kern County Public Health
Telephone: 661-321-3000
Last EDR Contact: 07/28/2020
Next Scheduled EDR Contact: 11/16/2020
Data Release Frequency: Varies

DRYCLEANERS: Cleaner Facilities

A list of drycleaner related facilities that have EPA ID numbers. These are facilities with certain SIC codes: power laundries, family and commercial; garment pressing and cleaner's agents; linen supply; coin-operated laundries and cleaning; drycleaning plants, except rugs; carpet and upholster cleaning; industrial launderers; laundry and garment services.

Date of Government Version: 06/04/2020
Date Data Arrived at EDR: 06/05/2020
Date Made Active in Reports: 08/17/2020
Number of Days to Update: 73

Source: Department of Toxic Substance Control
Telephone: 916-327-4498
Last EDR Contact: 08/24/2020
Next Scheduled EDR Contact: 12/13/2020
Data Release Frequency: Annually

DRYCLEAN AVAQMD: Antelope Valley Air Quality Management District Drycleaner Listing

A listing of dry cleaners in the Antelope Valley Air Quality Management District.

Date of Government Version: 05/28/2020
Date Data Arrived at EDR: 05/29/2020
Date Made Active in Reports: 08/12/2020
Number of Days to Update: 75

Source: Antelope Valley Air Quality Management District
Telephone: 661-723-8070
Last EDR Contact: 08/25/2020
Next Scheduled EDR Contact: 12/14/2020
Data Release Frequency: Varies

DRYCLEAN SOUTH COAST: South Coast Air Quality Management District Drycleaner Listing

A listing of dry cleaners in the South Coast Air Quality Management District

Date of Government Version: 03/25/2020
Date Data Arrived at EDR: 03/26/2020
Date Made Active in Reports: 06/15/2020
Number of Days to Update: 81

Source: South Coast Air Quality Management District
Telephone: 909-396-3211
Last EDR Contact: 08/17/2020
Next Scheduled EDR Contact: 12/07/2020
Data Release Frequency: Varies

EMI: Emissions Inventory Data

Toxics and criteria pollutant emissions data collected by the ARB and local air pollution agencies.

Date of Government Version: 12/31/2017
Date Data Arrived at EDR: 06/24/2019
Date Made Active in Reports: 08/22/2019
Number of Days to Update: 59

Source: California Air Resources Board
Telephone: 916-322-2990
Last EDR Contact: 06/16/2020
Next Scheduled EDR Contact: 09/28/2020
Data Release Frequency: Varies

ENF: Enforcement Action Listing

A listing of Water Board Enforcement Actions. Formal is everything except Oral/Verbal Communication, Notice of Violation, Expedited Payment Letter, and Staff Enforcement Letter.

Date of Government Version: 04/03/2020
Date Data Arrived at EDR: 04/07/2020
Date Made Active in Reports: 04/15/2020
Number of Days to Update: 8

Source: State Water Resources Control Board
Telephone: 916-445-9379
Last EDR Contact: 07/21/2020
Next Scheduled EDR Contact: 11/02/2020
Data Release Frequency: Varies

GOVERNMENT RECORDS SEARCHED / DATA CURRENCY TRACKING

Financial Assurance 1: Financial Assurance Information Listing

Financial Assurance information

Date of Government Version: 04/09/2020
Date Data Arrived at EDR: 04/10/2020
Date Made Active in Reports: 07/01/2020
Number of Days to Update: 82

Source: Department of Toxic Substances Control
Telephone: 916-255-3628
Last EDR Contact: 07/14/2020
Next Scheduled EDR Contact: 11/02/2020
Data Release Frequency: Varies

Financial Assurance 2: Financial Assurance Information Listing

A listing of financial assurance information for solid waste facilities. Financial assurance is intended to ensure that resources are available to pay for the cost of closure, post-closure care, and corrective measures if the owner or operator of a regulated facility is unable or unwilling to pay.

Date of Government Version: 05/14/2020
Date Data Arrived at EDR: 05/15/2020
Date Made Active in Reports: 07/27/2020
Number of Days to Update: 73

Source: California Integrated Waste Management Board
Telephone: 916-341-6066
Last EDR Contact: 08/04/2020
Next Scheduled EDR Contact: 11/23/2020
Data Release Frequency: Varies

HAZNET: Facility and Manifest Data

Facility and Manifest Data. The data is extracted from the copies of hazardous waste manifests received each year by the DTSC. The annual volume of manifests is typically 700,000 - 1,000,000 annually, representing approximately 350,000 - 500,000 shipments. Data are from the manifests submitted without correction, and therefore many contain some invalid values for data elements such as generator ID, TSD ID, waste category, and disposal method. This database begins with calendar year 1993.

Date of Government Version: 12/31/2019
Date Data Arrived at EDR: 04/15/2020
Date Made Active in Reports: 07/02/2020
Number of Days to Update: 78

Source: California Environmental Protection Agency
Telephone: 916-255-1136
Last EDR Contact: 07/06/2020
Next Scheduled EDR Contact: 10/19/2020
Data Release Frequency: Annually

ICE: ICE

Contains data pertaining to the Permitted Facilities with Inspections / Enforcements sites tracked in Envirostor.

Date of Government Version: 05/18/2020
Date Data Arrived at EDR: 05/19/2020
Date Made Active in Reports: 07/31/2020
Number of Days to Update: 73

Source: Department of Toxic Substances Control
Telephone: 877-786-9427
Last EDR Contact: 08/17/2020
Next Scheduled EDR Contact: 11/30/2020
Data Release Frequency: Quarterly

HIST CORTESE: Hazardous Waste & Substance Site List

The sites for the list are designated by the State Water Resource Control Board [LUST], the Integrated Waste Board [SWF/LS], and the Department of Toxic Substances Control [CALSITES]. This listing is no longer updated by the state agency.

Date of Government Version: 04/01/2001
Date Data Arrived at EDR: 01/22/2009
Date Made Active in Reports: 04/08/2009
Number of Days to Update: 76

Source: Department of Toxic Substances Control
Telephone: 916-323-3400
Last EDR Contact: 01/22/2009
Next Scheduled EDR Contact: N/A
Data Release Frequency: No Update Planned

HWP: EnviroStor Permitted Facilities Listing

Detailed information on permitted hazardous waste facilities and corrective action ("cleanups") tracked in EnviroStor.

Date of Government Version: 05/18/2020
Date Data Arrived at EDR: 05/18/2020
Date Made Active in Reports: 07/31/2020
Number of Days to Update: 74

Source: Department of Toxic Substances Control
Telephone: 916-323-3400
Last EDR Contact: 08/17/2020
Next Scheduled EDR Contact: 11/30/2020
Data Release Frequency: Quarterly

GOVERNMENT RECORDS SEARCHED / DATA CURRENCY TRACKING

HWT: Registered Hazardous Waste Transporter Database

A listing of hazardous waste transporters. In California, unless specifically exempted, it is unlawful for any person to transport hazardous wastes unless the person holds a valid registration issued by DTSC. A hazardous waste transporter registration is valid for one year and is assigned a unique registration number.

Date of Government Version: 04/06/2020	Source: Department of Toxic Substances Control
Date Data Arrived at EDR: 04/08/2020	Telephone: 916-440-7145
Date Made Active in Reports: 06/26/2020	Last EDR Contact: 07/07/2020
Number of Days to Update: 79	Next Scheduled EDR Contact: 10/19/2020
	Data Release Frequency: Quarterly

MINES: Mines Site Location Listing

A listing of mine site locations from the Office of Mine Reclamation.

Date of Government Version: 06/08/2020	Source: Department of Conservation
Date Data Arrived at EDR: 06/09/2020	Telephone: 916-322-1080
Date Made Active in Reports: 08/19/2020	Last EDR Contact: 06/09/2020
Number of Days to Update: 71	Next Scheduled EDR Contact: 09/21/2020
	Data Release Frequency: Quarterly

MWMP: Medical Waste Management Program Listing

The Medical Waste Management Program (MWMP) ensures the proper handling and disposal of medical waste by permitting and inspecting medical waste Offsite Treatment Facilities (PDF) and Transfer Stations (PDF) throughout the state. MWMP also oversees all Medical Waste Transporters.

Date of Government Version: 05/28/2020	Source: Department of Public Health
Date Data Arrived at EDR: 06/02/2020	Telephone: 916-558-1784
Date Made Active in Reports: 08/14/2020	Last EDR Contact: 06/02/2020
Number of Days to Update: 73	Next Scheduled EDR Contact: 09/14/2020
	Data Release Frequency: Varies

NPDES: NPDES Permits Listing

A listing of NPDES permits, including stormwater.

Date of Government Version: 05/12/2020	Source: State Water Resources Control Board
Date Data Arrived at EDR: 05/12/2020	Telephone: 916-445-9379
Date Made Active in Reports: 07/28/2020	Last EDR Contact: 08/10/2020
Number of Days to Update: 77	Next Scheduled EDR Contact: 11/23/2020
	Data Release Frequency: Quarterly

PEST LIC: Pesticide Regulation Licenses Listing

A listing of licenses and certificates issued by the Department of Pesticide Regulation. The DPR issues licenses and/or certificates to: Persons and businesses that apply or sell pesticides; Pest control dealers and brokers; Persons who advise on agricultural pesticide applications.

Date of Government Version: 06/01/2020	Source: Department of Pesticide Regulation
Date Data Arrived at EDR: 06/02/2020	Telephone: 916-445-4038
Date Made Active in Reports: 08/14/2020	Last EDR Contact: 06/02/2020
Number of Days to Update: 73	Next Scheduled EDR Contact: 09/14/2020
	Data Release Frequency: Quarterly

PROC: Certified Processors Database

A listing of certified processors.

Date of Government Version: 06/08/2020	Source: Department of Conservation
Date Data Arrived at EDR: 06/09/2020	Telephone: 916-323-3836
Date Made Active in Reports: 08/19/2020	Last EDR Contact: 06/09/2020
Number of Days to Update: 71	Next Scheduled EDR Contact: 09/21/2020
	Data Release Frequency: Quarterly

GOVERNMENT RECORDS SEARCHED / DATA CURRENCY TRACKING

NOTIFY 65: Proposition 65 Records

Listings of all Proposition 65 incidents reported to counties by the State Water Resources Control Board and the Regional Water Quality Control Board. This database is no longer updated by the reporting agency.

Date of Government Version: 03/12/2020	Source: State Water Resources Control Board
Date Data Arrived at EDR: 03/13/2020	Telephone: 916-445-3846
Date Made Active in Reports: 05/21/2020	Last EDR Contact: 08/20/2020
Number of Days to Update: 69	Next Scheduled EDR Contact: 09/28/2020
	Data Release Frequency: No Update Planned

UIC: UIC Listing

A listing of wells identified as underground injection wells, in the California Oil and Gas Wells database.

Date of Government Version: 06/06/2020	Source: Department of Conservation
Date Data Arrived at EDR: 06/09/2020	Telephone: 916-445-2408
Date Made Active in Reports: 08/20/2020	Last EDR Contact: 06/09/2020
Number of Days to Update: 72	Next Scheduled EDR Contact: 09/21/2020
	Data Release Frequency: Varies

UIC GEO: Underground Injection Control Sites (GEOTRACKER)

Underground control injection sites

Date of Government Version: 06/08/2020	Source: State Water Resource Control Board
Date Data Arrived at EDR: 06/09/2020	Telephone: 866-480-1028
Date Made Active in Reports: 08/19/2020	Last EDR Contact: 06/09/2020
Number of Days to Update: 71	Next Scheduled EDR Contact: 09/21/2020
	Data Release Frequency: Varies

WASTEWATER PITS: Oil Wastewater Pits Listing

Water officials discovered that oil producers have been dumping chemical-laden wastewater into hundreds of unlined pits that are operating without proper permits. Inspections completed by the Central Valley Regional Water Quality Control Board revealed the existence of previously unidentified waste sites. The water boards review found that more than one-third of the region's active disposal pits are operating without permission.

Date of Government Version: 11/19/2019	Source: RWQCB, Central Valley Region
Date Data Arrived at EDR: 01/07/2020	Telephone: 559-445-5577
Date Made Active in Reports: 03/09/2020	Last EDR Contact: 07/09/2020
Number of Days to Update: 62	Next Scheduled EDR Contact: 10/19/2020
	Data Release Frequency: Varies

WDS: Waste Discharge System

Sites which have been issued waste discharge requirements.

Date of Government Version: 06/19/2007	Source: State Water Resources Control Board
Date Data Arrived at EDR: 06/20/2007	Telephone: 916-341-5227
Date Made Active in Reports: 06/29/2007	Last EDR Contact: 08/11/2020
Number of Days to Update: 9	Next Scheduled EDR Contact: 11/30/2020
	Data Release Frequency: No Update Planned

WIP: Well Investigation Program Case List

Well Investigation Program case in the San Gabriel and San Fernando Valley area.

Date of Government Version: 07/03/2009	Source: Los Angeles Water Quality Control Board
Date Data Arrived at EDR: 07/21/2009	Telephone: 213-576-6726
Date Made Active in Reports: 08/03/2009	Last EDR Contact: 06/17/2020
Number of Days to Update: 13	Next Scheduled EDR Contact: 10/05/2020
	Data Release Frequency: No Update Planned

MILITARY PRIV SITES: Military Privatized Sites (GEOTRACKER)

Military privatized sites

GOVERNMENT RECORDS SEARCHED / DATA CURRENCY TRACKING

Date of Government Version: 06/08/2020
Date Data Arrived at EDR: 06/09/2020
Date Made Active in Reports: 08/19/2020
Number of Days to Update: 71

Source: State Water Resources Control Board
Telephone: 866-480-1028
Last EDR Contact: 06/09/2020
Next Scheduled EDR Contact: 09/21/2020
Data Release Frequency: Varies

PROJECT: Project Sites (GEOTRACKER) Projects sites

Date of Government Version: 06/08/2020
Date Data Arrived at EDR: 06/09/2020
Date Made Active in Reports: 08/19/2020
Number of Days to Update: 71

Source: State Water Resources Control Board
Telephone: 866-480-1028
Last EDR Contact: 06/09/2020
Next Scheduled EDR Contact: 09/21/2020
Data Release Frequency: Varies

WDR: Waste Discharge Requirements Listing

In general, the Waste Discharge Requirements (WDRs) Program (sometimes also referred to as the "Non Chapter 15 (Non 15) Program") regulates point discharges that are exempt pursuant to Subsection 20090 of Title 27 and not subject to the Federal Water Pollution Control Act. Exemptions from Title 27 may be granted for nine categories of discharges (e.g., sewage, wastewater, etc.) that meet, and continue to meet, the preconditions listed for each specific exemption. The scope of the WDRs Program also includes the discharge of wastes classified as inert, pursuant to section 20230 of Title 27.

Date of Government Version: 06/08/2020
Date Data Arrived at EDR: 06/09/2020
Date Made Active in Reports: 08/20/2020
Number of Days to Update: 72

Source: State Water Resources Control Board
Telephone: 916-341-5810
Last EDR Contact: 06/09/2020
Next Scheduled EDR Contact: 09/21/2020
Data Release Frequency: Quarterly

CIWQS: California Integrated Water Quality System

The California Integrated Water Quality System (CIWQS) is a computer system used by the State and Regional Water Quality Control Boards to track information about places of environmental interest, manage permits and other orders, track inspections, and manage violations and enforcement activities.

Date of Government Version: 06/01/2020
Date Data Arrived at EDR: 06/02/2020
Date Made Active in Reports: 08/14/2020
Number of Days to Update: 73

Source: State Water Resources Control Board
Telephone: 866-794-4977
Last EDR Contact: 06/02/2020
Next Scheduled EDR Contact: 09/14/2020
Data Release Frequency: Varies

CERS: CalEPA Regulated Site Portal Data

The CalEPA Regulated Site Portal database combines data about environmentally regulated sites and facilities in California into a single database. It combines data from a variety of state and federal databases, and provides an overview of regulated activities across the spectrum of environmental programs for any given location in California. These activities include hazardous materials and waste, state and federal cleanups, impacted ground and surface waters, and toxic materials

Date of Government Version: 04/20/2020
Date Data Arrived at EDR: 04/21/2020
Date Made Active in Reports: 07/13/2020
Number of Days to Update: 83

Source: California Environmental Protection Agency
Telephone: 916-323-2514
Last EDR Contact: 07/21/2020
Next Scheduled EDR Contact: 11/02/2020
Data Release Frequency: Varies

NON-CASE INFO: Non-Case Information Sites (GEOTRACKER)

Non-Case Information sites

Date of Government Version: 06/08/2020
Date Data Arrived at EDR: 06/09/2020
Date Made Active in Reports: 08/19/2020
Number of Days to Update: 71

Source: State Water Resources Control Board
Telephone: 866-480-1028
Last EDR Contact: 06/09/2020
Next Scheduled EDR Contact: 09/21/2020
Data Release Frequency: Varies

GOVERNMENT RECORDS SEARCHED / DATA CURRENCY TRACKING

OTHER OIL GAS: Other Oil & Gas Projects Sites (GEOTRACKER)

Other Oil & Gas Projects sites

Date of Government Version: 06/08/2020
Date Data Arrived at EDR: 06/09/2020
Date Made Active in Reports: 08/19/2020
Number of Days to Update: 71

Source: State Water Resources Control Board
Telephone: 866-480-1028
Last EDR Contact: 06/09/2020
Next Scheduled EDR Contact: 09/21/2020
Data Release Frequency: Varies

PROD WATER PONDS: Produced Water Ponds Sites (GEOTRACKER)

Produced water ponds sites

Date of Government Version: 06/08/2020
Date Data Arrived at EDR: 06/09/2020
Date Made Active in Reports: 08/19/2020
Number of Days to Update: 71

Source: State Water Resources Control Board
Telephone: 866-480-1028
Last EDR Contact: 06/09/2020
Next Scheduled EDR Contact: 09/21/2020
Data Release Frequency: Varies

SAMPLING POINT: Sampling Point ? Public Sites (GEOTRACKER)

Sampling point - public sites

Date of Government Version: 06/08/2020
Date Data Arrived at EDR: 06/09/2020
Date Made Active in Reports: 08/19/2020
Number of Days to Update: 71

Source: State Water Resources Control Board
Telephone: 866-480-1028
Last EDR Contact: 06/09/2020
Next Scheduled EDR Contact: 09/21/2020
Data Release Frequency: Varies

WELL STIM PROJ: Well Stimulation Project (GEOTRACKER)

Includes areas of groundwater monitoring plans, a depiction of the monitoring network, and the facilities, boundaries, and subsurface characteristics of the oilfield and the features (oil and gas wells, produced water ponds, UIC wells, water supply wells, etc?) being monitored

Date of Government Version: 06/08/2020
Date Data Arrived at EDR: 06/09/2020
Date Made Active in Reports: 08/19/2020
Number of Days to Update: 71

Source: State Water Resources Control Board
Telephone: 866-480-1028
Last EDR Contact: 06/09/2020
Next Scheduled EDR Contact: 09/21/2020
Data Release Frequency: Varies

PCS: Permit Compliance System

PCS is a computerized management information system that contains data on National Pollutant Discharge Elimination System (NPDES) permit holding facilities. PCS tracks the permit, compliance, and enforcement status of NPDES facilities.

Date of Government Version: 07/14/2011
Date Data Arrived at EDR: 08/05/2011
Date Made Active in Reports: 09/29/2011
Number of Days to Update: 55

Source: EPA, Office of Water
Telephone: 202-564-2496
Last EDR Contact: 06/08/2020
Next Scheduled EDR Contact: 09/21/2020
Data Release Frequency: Semi-Annually

PCS INACTIVE: Listing of Inactive PCS Permits

An inactive permit is a facility that has shut down or is no longer discharging.

Date of Government Version: 11/05/2014
Date Data Arrived at EDR: 01/06/2015
Date Made Active in Reports: 05/06/2015
Number of Days to Update: 120

Source: EPA
Telephone: 202-564-2496
Last EDR Contact: 07/09/2020
Next Scheduled EDR Contact: 10/19/2020
Data Release Frequency: Semi-Annually

PCS ENF: Enforcement data

No description is available for this data

GOVERNMENT RECORDS SEARCHED / DATA CURRENCY TRACKING

Date of Government Version: 12/31/2014
Date Data Arrived at EDR: 02/05/2015
Date Made Active in Reports: 03/06/2015
Number of Days to Update: 29

Source: EPA
Telephone: 202-564-2497
Last EDR Contact: 07/01/2020
Next Scheduled EDR Contact: 10/19/2020
Data Release Frequency: Varies

MINES MRDS: Mineral Resources Data System Mineral Resources Data System

Date of Government Version: 04/06/2018
Date Data Arrived at EDR: 10/21/2019
Date Made Active in Reports: 10/24/2019
Number of Days to Update: 3

Source: USGS
Telephone: 703-648-6533
Last EDR Contact: 05/21/2020
Next Scheduled EDR Contact: 09/07/2020
Data Release Frequency: Varies

HWTS: Hazardous Waste Tracking System

DTSC maintains the Hazardous Waste Tracking System that stores ID number information since the early 1980s and manifest data since 1993. The system collects both manifest copies from the generator and destination facility.

Date of Government Version: 04/08/2020
Date Data Arrived at EDR: 04/09/2020
Date Made Active in Reports: 07/01/2020
Number of Days to Update: 83

Source: Department of Toxic Substances Control
Telephone: 916-324-2444
Last EDR Contact: 08/02/2020
Next Scheduled EDR Contact: 10/18/2020
Data Release Frequency: Varies

EDR HIGH RISK HISTORICAL RECORDS

EDR Exclusive Records

EDR MGP: EDR Proprietary Manufactured Gas Plants

The EDR Proprietary Manufactured Gas Plant Database includes records of coal gas plants (manufactured gas plants) compiled by EDR's researchers. Manufactured gas sites were used in the United States from the 1800's to 1950's to produce a gas that could be distributed and used as fuel. These plants used whale oil, rosin, coal, or a mixture of coal, oil, and water that also produced a significant amount of waste. Many of the byproducts of the gas production, such as coal tar (oily waste containing volatile and non-volatile chemicals), sludges, oils and other compounds are potentially hazardous to human health and the environment. The byproduct from this process was frequently disposed of directly at the plant site and can remain or spread slowly, serving as a continuous source of soil and groundwater contamination.

Date of Government Version: N/A
Date Data Arrived at EDR: N/A
Date Made Active in Reports: N/A
Number of Days to Update: N/A

Source: EDR, Inc.
Telephone: N/A
Last EDR Contact: N/A
Next Scheduled EDR Contact: N/A
Data Release Frequency: No Update Planned

EDR Hist Auto: EDR Exclusive Historical Auto Stations

EDR has searched selected national collections of business directories and has collected listings of potential gas station/filling station/service station sites that were available to EDR researchers. EDR's review was limited to those categories of sources that might, in EDR's opinion, include gas station/filling station/service station establishments. The categories reviewed included, but were not limited to gas, gas station, gasoline station, filling station, auto, automobile repair, auto service station, service station, etc. This database falls within a category of information EDR classifies as "High Risk Historical Records", or HRHR. EDR's HRHR effort presents unique and sometimes proprietary data about past sites and operations that typically create environmental concerns, but may not show up in current government records searches.

Date of Government Version: N/A
Date Data Arrived at EDR: N/A
Date Made Active in Reports: N/A
Number of Days to Update: N/A

Source: EDR, Inc.
Telephone: N/A
Last EDR Contact: N/A
Next Scheduled EDR Contact: N/A
Data Release Frequency: Varies

GOVERNMENT RECORDS SEARCHED / DATA CURRENCY TRACKING

EDR Hist Cleaner: EDR Exclusive Historical Cleaners

EDR has searched selected national collections of business directories and has collected listings of potential dry cleaner sites that were available to EDR researchers. EDR's review was limited to those categories of sources that might, in EDR's opinion, include dry cleaning establishments. The categories reviewed included, but were not limited to dry cleaners, cleaners, laundry, laundromat, cleaning/laundry, wash & dry etc. This database falls within a category of information EDR classifies as "High Risk Historical Records", or HRHR. EDR's HRHR effort presents unique and sometimes proprietary data about past sites and operations that typically create environmental concerns, but may not show up in current government records searches.

Date of Government Version: N/A	Source: EDR, Inc.
Date Data Arrived at EDR: N/A	Telephone: N/A
Date Made Active in Reports: N/A	Last EDR Contact: N/A
Number of Days to Update: N/A	Next Scheduled EDR Contact: N/A
	Data Release Frequency: Varies

EDR RECOVERED GOVERNMENT ARCHIVES

Exclusive Recovered Govt. Archives

RGA LF: Recovered Government Archive Solid Waste Facilities List

The EDR Recovered Government Archive Landfill database provides a list of landfills derived from historical databases and includes many records that no longer appear in current government lists. Compiled from Records formerly available from the Department of Resources Recycling and Recovery in California.

Date of Government Version: N/A	Source: Department of Resources Recycling and Recovery
Date Data Arrived at EDR: 07/01/2013	Telephone: N/A
Date Made Active in Reports: 01/13/2014	Last EDR Contact: 06/01/2012
Number of Days to Update: 196	Next Scheduled EDR Contact: N/A
	Data Release Frequency: Varies

RGA LUST: Recovered Government Archive Leaking Underground Storage Tank

The EDR Recovered Government Archive Leaking Underground Storage Tank database provides a list of LUST incidents derived from historical databases and includes many records that no longer appear in current government lists. Compiled from Records formerly available from the State Water Resources Control Board in California.

Date of Government Version: N/A	Source: State Water Resources Control Board
Date Data Arrived at EDR: 07/01/2013	Telephone: N/A
Date Made Active in Reports: 12/30/2013	Last EDR Contact: 06/01/2012
Number of Days to Update: 182	Next Scheduled EDR Contact: N/A
	Data Release Frequency: Varies

COUNTY RECORDS

ALAMEDA COUNTY:

CS ALAMEDA: Contaminated Sites

A listing of contaminated sites overseen by the Toxic Release Program (oil and groundwater contamination from chemical releases and spills) and the Leaking Underground Storage Tank Program (soil and ground water contamination from leaking petroleum USTs).

Date of Government Version: 01/09/2019	Source: Alameda County Environmental Health Services
Date Data Arrived at EDR: 01/11/2019	Telephone: 510-567-6700
Date Made Active in Reports: 03/05/2019	Last EDR Contact: 06/30/2020
Number of Days to Update: 53	Next Scheduled EDR Contact: 10/19/2020
	Data Release Frequency: Semi-Annually

UST ALAMEDA: Underground Tanks

Underground storage tank sites located in Alameda county.

Date of Government Version: 06/30/2020	Source: Alameda County Environmental Health Services
Date Data Arrived at EDR: 07/01/2020	Telephone: 510-567-6700
Date Made Active in Reports: 07/17/2020	Last EDR Contact: 06/30/2020
Number of Days to Update: 16	Next Scheduled EDR Contact: 10/19/2020
	Data Release Frequency: Semi-Annually

AMADOR COUNTY:

GOVERNMENT RECORDS SEARCHED / DATA CURRENCY TRACKING

CUPA AMADOR: CUPA Facility List Cupa Facility List

Date of Government Version: 05/18/2020
Date Data Arrived at EDR: 05/19/2020
Date Made Active in Reports: 06/01/2020
Number of Days to Update: 13

Source: Amador County Environmental Health
Telephone: 209-223-6439
Last EDR Contact: 07/28/2020
Next Scheduled EDR Contact: 11/16/2020
Data Release Frequency: Varies

BUTTE COUNTY:

CUPA BUTTE: CUPA Facility Listing Cupa facility list.

Date of Government Version: 04/21/2017
Date Data Arrived at EDR: 04/25/2017
Date Made Active in Reports: 08/09/2017
Number of Days to Update: 106

Source: Public Health Department
Telephone: 530-538-7149
Last EDR Contact: 06/30/2020
Next Scheduled EDR Contact: 10/19/2020
Data Release Frequency: No Update Planned

CALVERAS COUNTY:

CUPA CALVERAS: CUPA Facility Listing Cupa Facility Listing

Date of Government Version: 03/27/2020
Date Data Arrived at EDR: 03/31/2020
Date Made Active in Reports: 06/15/2020
Number of Days to Update: 76

Source: Calveras County Environmental Health
Telephone: 209-754-6399
Last EDR Contact: 06/17/2020
Next Scheduled EDR Contact: 10/05/2020
Data Release Frequency: Quarterly

COLUSA COUNTY:

CUPA COLUSA: CUPA Facility List Cupa facility list.

Date of Government Version: 04/06/2020
Date Data Arrived at EDR: 04/23/2020
Date Made Active in Reports: 07/10/2020
Number of Days to Update: 78

Source: Health & Human Services
Telephone: 530-458-0396
Last EDR Contact: 07/28/2020
Next Scheduled EDR Contact: 11/16/2020
Data Release Frequency: Semi-Annually

CONTRA COSTA COUNTY:

SL CONTRA COSTA: Site List

List includes sites from the underground tank, hazardous waste generator and business plan/2185 programs.

Date of Government Version: 04/01/2020
Date Data Arrived at EDR: 04/20/2020
Date Made Active in Reports: 07/06/2020
Number of Days to Update: 77

Source: Contra Costa Health Services Department
Telephone: 925-646-2286
Last EDR Contact: 07/21/2020
Next Scheduled EDR Contact: 11/09/2020
Data Release Frequency: Semi-Annually

DEL NORTE COUNTY:

GOVERNMENT RECORDS SEARCHED / DATA CURRENCY TRACKING

CUPA DEL NORTE: CUPA Facility List Cupa Facility list

Date of Government Version: 04/16/2020
Date Data Arrived at EDR: 04/20/2020
Date Made Active in Reports: 07/08/2020
Number of Days to Update: 79

Source: Del Norte County Environmental Health Division
Telephone: 707-465-0426
Last EDR Contact: 08/13/2020
Next Scheduled EDR Contact: 11/09/2020
Data Release Frequency: Varies

EL DORADO COUNTY:

CUPA EL DORADO: CUPA Facility List CUPA facility list.

Date of Government Version: 05/07/2020
Date Data Arrived at EDR: 05/07/2020
Date Made Active in Reports: 07/23/2020
Number of Days to Update: 77

Source: El Dorado County Environmental Management Department
Telephone: 530-621-6623
Last EDR Contact: 08/13/2020
Next Scheduled EDR Contact: 11/09/2020
Data Release Frequency: Varies

FRESNO COUNTY:

CUPA FRESNO: CUPA Resources List

Certified Unified Program Agency. CUPA's are responsible for implementing a unified hazardous materials and hazardous waste management regulatory program. The agency provides oversight of businesses that deal with hazardous materials, operate underground storage tanks or aboveground storage tanks.

Date of Government Version: 01/10/2020
Date Data Arrived at EDR: 03/31/2020
Date Made Active in Reports: 06/15/2020
Number of Days to Update: 76

Source: Dept. of Community Health
Telephone: 559-445-3271
Last EDR Contact: 06/30/2020
Next Scheduled EDR Contact: 10/12/2020
Data Release Frequency: Semi-Annually

GLENN COUNTY:

CUPA GLENN: CUPA Facility List Cupa facility list

Date of Government Version: 01/22/2018
Date Data Arrived at EDR: 01/24/2018
Date Made Active in Reports: 03/14/2018
Number of Days to Update: 49

Source: Glenn County Air Pollution Control District
Telephone: 830-934-6500
Last EDR Contact: 07/14/2020
Next Scheduled EDR Contact: 11/02/2020
Data Release Frequency: No Update Planned

HUMBOLDT COUNTY:

CUPA HUMBOLDT: CUPA Facility List CUPA facility list.

Date of Government Version: 05/19/2020
Date Data Arrived at EDR: 05/20/2020
Date Made Active in Reports: 06/15/2020
Number of Days to Update: 26

Source: Humboldt County Environmental Health
Telephone: N/A
Last EDR Contact: 08/11/2020
Next Scheduled EDR Contact: 11/30/2020
Data Release Frequency: Semi-Annually

IMPERIAL COUNTY:

GOVERNMENT RECORDS SEARCHED / DATA CURRENCY TRACKING

CUPA IMPERIAL: CUPA Facility List Cupa facility list.

Date of Government Version: 04/09/2020
Date Data Arrived at EDR: 04/10/2020
Date Made Active in Reports: 07/01/2020
Number of Days to Update: 82

Source: San Diego Border Field Office
Telephone: 760-339-2777
Last EDR Contact: 07/14/2020
Next Scheduled EDR Contact: 11/02/2020
Data Release Frequency: Varies

INYO COUNTY:

CUPA INYO: CUPA Facility List Cupa facility list.

Date of Government Version: 04/02/2018
Date Data Arrived at EDR: 04/03/2018
Date Made Active in Reports: 06/14/2018
Number of Days to Update: 73

Source: Inyo County Environmental Health Services
Telephone: 760-878-0238
Last EDR Contact: 08/11/2020
Next Scheduled EDR Contact: 11/30/2020
Data Release Frequency: Varies

KERN COUNTY:

UST KERN: Underground Storage Tank Sites & Tank Listing Kern County Sites and Tanks Listing.

Date of Government Version: 04/29/2020
Date Data Arrived at EDR: 05/05/2020
Date Made Active in Reports: 07/17/2020
Number of Days to Update: 73

Source: Kern County Environment Health Services Department
Telephone: 661-862-8700
Last EDR Contact: 07/28/2020
Next Scheduled EDR Contact: 11/16/2020
Data Release Frequency: Quarterly

KINGS COUNTY:

CUPA KINGS: CUPA Facility List

A listing of sites included in the county's Certified Unified Program Agency database. California's Secretary for Environmental Protection established the unified hazardous materials and hazardous waste regulatory program as required by chapter 6.11 of the California Health and Safety Code. The Unified Program consolidates the administration, permits, inspections, and enforcement activities.

Date of Government Version: 05/11/2020
Date Data Arrived at EDR: 05/12/2020
Date Made Active in Reports: 07/27/2020
Number of Days to Update: 76

Source: Kings County Department of Public Health
Telephone: 559-584-1411
Last EDR Contact: 08/21/2020
Next Scheduled EDR Contact: 11/30/2020
Data Release Frequency: Varies

LAKE COUNTY:

CUPA LAKE: CUPA Facility List Cupa facility list

Date of Government Version: 04/20/2020
Date Data Arrived at EDR: 04/28/2020
Date Made Active in Reports: 07/14/2020
Number of Days to Update: 77

Source: Lake County Environmental Health
Telephone: 707-263-1164
Last EDR Contact: 07/08/2020
Next Scheduled EDR Contact: 10/26/2020
Data Release Frequency: Varies

LASSEN COUNTY:

GOVERNMENT RECORDS SEARCHED / DATA CURRENCY TRACKING

CUPA LASSEN: CUPA Facility List Cupa facility list

Date of Government Version: 01/30/2020
Date Data Arrived at EDR: 01/31/2020
Date Made Active in Reports: 04/09/2020
Number of Days to Update: 69

Source: Lassen County Environmental Health
Telephone: 530-251-8528
Last EDR Contact: 08/11/2020
Next Scheduled EDR Contact: 11/02/2020
Data Release Frequency: Varies

LOS ANGELES COUNTY:

AOCONCERN: Key Areas of Concerns in Los Angeles County

San Gabriel Valley areas where VOC contamination is at or above the MCL as designated by region 9 EPA office. Date of Government Version: 3/30/2009 Exide Site area is a cleanup plan of lead-impacted soil surrounding the former Exide Facility as designated by the DTSC. Date of Government Version: 7/17/2017

Date of Government Version: 03/30/2009
Date Data Arrived at EDR: 03/31/2009
Date Made Active in Reports: 10/23/2009
Number of Days to Update: 206

Source: N/A
Telephone: N/A
Last EDR Contact: 06/10/2020
Next Scheduled EDR Contact: 09/28/2020
Data Release Frequency: No Update Planned

HMS LOS ANGELES: HMS: Street Number List

Industrial Waste and Underground Storage Tank Sites.

Date of Government Version: 03/26/2020
Date Data Arrived at EDR: 03/26/2020
Date Made Active in Reports: 06/15/2020
Number of Days to Update: 81

Source: Department of Public Works
Telephone: 626-458-3517
Last EDR Contact: 06/30/2020
Next Scheduled EDR Contact: 10/19/2020
Data Release Frequency: Semi-Annually

LF LOS ANGELES: List of Solid Waste Facilities

Solid Waste Facilities in Los Angeles County.

Date of Government Version: 04/13/2020
Date Data Arrived at EDR: 04/14/2020
Date Made Active in Reports: 07/01/2020
Number of Days to Update: 78

Source: La County Department of Public Works
Telephone: 818-458-5185
Last EDR Contact: 07/13/2020
Next Scheduled EDR Contact: 10/26/2020
Data Release Frequency: Varies

LF LOS ANGELES CITY: City of Los Angeles Landfills

Landfills owned and maintained by the City of Los Angeles.

Date of Government Version: 01/01/2019
Date Data Arrived at EDR: 01/15/2019
Date Made Active in Reports: 03/07/2019
Number of Days to Update: 51

Source: Engineering & Construction Division
Telephone: 213-473-7869
Last EDR Contact: 07/08/2020
Next Scheduled EDR Contact: 10/26/2020
Data Release Frequency: Varies

LOS ANGELES AST: Active & Inactive AST Inventory

A listing of active & inactive above ground petroleum storage tank site locations, located in the City of Los Angeles.

Date of Government Version: 06/01/2019
Date Data Arrived at EDR: 06/25/2019
Date Made Active in Reports: 08/22/2019
Number of Days to Update: 58

Source: Los Angeles Fire Department
Telephone: 213-978-3800
Last EDR Contact: 06/25/2020
Next Scheduled EDR Contact: 10/05/2020
Data Release Frequency: Varies

GOVERNMENT RECORDS SEARCHED / DATA CURRENCY TRACKING

LOS ANGELES CO LF METHANE: Methane Producing Landfills

This data was created on April 30, 2012 to represent known disposal sites in Los Angeles County that may produce and emanate methane gas. The shapefile contains disposal sites within Los Angeles County that once accepted degradable refuse material. Information used to create this data was extracted from a landfill survey performed by County Engineers (Major Waste System Map, 1973) as well as historical records from CalRecycle, Regional Water Quality Control Board, and Los Angeles County Department of Public Health

Date of Government Version: 04/30/2012	Source: Los Angeles County Department of Public Works
Date Data Arrived at EDR: 04/17/2019	Telephone: 626-458-6973
Date Made Active in Reports: 05/29/2019	Last EDR Contact: 08/11/2020
Number of Days to Update: 42	Next Scheduled EDR Contact: 10/26/2020
	Data Release Frequency: No Update Planned

LOS ANGELES HM: Active & Inactive Hazardous Materials Inventory

A listing of active & inactive hazardous materials facility locations, located in the City of Los Angeles.

Date of Government Version: 06/01/2019	Source: Los Angeles Fire Department
Date Data Arrived at EDR: 06/25/2019	Telephone: 213-978-3800
Date Made Active in Reports: 08/22/2019	Last EDR Contact: 06/25/2020
Number of Days to Update: 58	Next Scheduled EDR Contact: 10/05/2020
	Data Release Frequency: Varies

LOS ANGELES UST: Active & Inactive UST Inventory

A listing of active & inactive underground storage tank site locations and underground storage tank historical sites, located in the City of Los Angeles.

Date of Government Version: 06/01/2019	Source: Los Angeles Fire Department
Date Data Arrived at EDR: 06/25/2019	Telephone: 213-978-3800
Date Made Active in Reports: 08/22/2019	Last EDR Contact: 06/25/2020
Number of Days to Update: 58	Next Scheduled EDR Contact: 10/05/2020
	Data Release Frequency: Varies

SITE MIT LOS ANGELES: Site Mitigation List

Industrial sites that have had some sort of spill or complaint.

Date of Government Version: 03/25/2020	Source: Community Health Services
Date Data Arrived at EDR: 04/14/2020	Telephone: 323-890-7806
Date Made Active in Reports: 07/01/2020	Last EDR Contact: 07/17/2020
Number of Days to Update: 78	Next Scheduled EDR Contact: 10/26/2020
	Data Release Frequency: Annually

UST EL SEGUNDO: City of El Segundo Underground Storage Tank

Underground storage tank sites located in El Segundo city.

Date of Government Version: 01/21/2017	Source: City of El Segundo Fire Department
Date Data Arrived at EDR: 04/19/2017	Telephone: 310-524-2236
Date Made Active in Reports: 05/10/2017	Last EDR Contact: 07/08/2020
Number of Days to Update: 21	Next Scheduled EDR Contact: 10/26/2020
	Data Release Frequency: No Update Planned

UST LONG BEACH: City of Long Beach Underground Storage Tank

Underground storage tank sites located in the city of Long Beach.

Date of Government Version: 04/22/2019	Source: City of Long Beach Fire Department
Date Data Arrived at EDR: 04/23/2019	Telephone: 562-570-2563
Date Made Active in Reports: 06/27/2019	Last EDR Contact: 07/14/2020
Number of Days to Update: 65	Next Scheduled EDR Contact: 11/02/2020
	Data Release Frequency: Varies

GOVERNMENT RECORDS SEARCHED / DATA CURRENCY TRACKING

UST TORRANCE: City of Torrance Underground Storage Tank
Underground storage tank sites located in the city of Torrance.

Date of Government Version: 06/27/2019	Source: City of Torrance Fire Department
Date Data Arrived at EDR: 07/30/2019	Telephone: 310-618-2973
Date Made Active in Reports: 10/02/2019	Last EDR Contact: 07/14/2020
Number of Days to Update: 64	Next Scheduled EDR Contact: 11/02/2020
	Data Release Frequency: Semi-Annually

MADERA COUNTY:

CUPA MADERA: CUPA Facility List

A listing of sites included in the county's Certified Unified Program Agency database. California's Secretary for Environmental Protection established the unified hazardous materials and hazardous waste regulatory program as required by chapter 6.11 of the California Health and Safety Code. The Unified Program consolidates the administration, permits, inspections, and enforcement activities.

Date of Government Version: 02/24/2020	Source: Madera County Environmental Health
Date Data Arrived at EDR: 02/25/2020	Telephone: 559-675-7823
Date Made Active in Reports: 05/07/2020	Last EDR Contact: 08/04/2020
Number of Days to Update: 72	Next Scheduled EDR Contact: 11/30/2020
	Data Release Frequency: Varies

MARIN COUNTY:

UST MARIN: Underground Storage Tank Sites
Currently permitted USTs in Marin County.

Date of Government Version: 09/26/2018	Source: Public Works Department Waste Management
Date Data Arrived at EDR: 10/04/2018	Telephone: 415-473-6647
Date Made Active in Reports: 11/02/2018	Last EDR Contact: 06/24/2020
Number of Days to Update: 29	Next Scheduled EDR Contact: 10/12/2020
	Data Release Frequency: Semi-Annually

MERCED COUNTY:

CUPA MERCED: CUPA Facility List
CUPA facility list.

Date of Government Version: 07/28/2020	Source: Merced County Environmental Health
Date Data Arrived at EDR: 07/30/2020	Telephone: 209-381-1094
Date Made Active in Reports: 07/31/2020	Last EDR Contact: 07/24/2020
Number of Days to Update: 1	Next Scheduled EDR Contact: 11/30/2020
	Data Release Frequency: Varies

MONO COUNTY:

CUPA MONO: CUPA Facility List
CUPA Facility List

Date of Government Version: 05/15/2020	Source: Mono County Health Department
Date Data Arrived at EDR: 06/02/2020	Telephone: 760-932-5580
Date Made Active in Reports: 08/14/2020	Last EDR Contact: 08/19/2020
Number of Days to Update: 73	Next Scheduled EDR Contact: 12/07/2020
	Data Release Frequency: Varies

MONTEREY COUNTY:

GOVERNMENT RECORDS SEARCHED / DATA CURRENCY TRACKING

CUPA MONTEREY: CUPA Facility Listing

CUPA Program listing from the Environmental Health Division.

Date of Government Version: 07/13/2020
Date Data Arrived at EDR: 07/15/2020
Date Made Active in Reports: 07/31/2020
Number of Days to Update: 16

Source: Monterey County Health Department
Telephone: 831-796-1297
Last EDR Contact: 07/08/2020
Next Scheduled EDR Contact: 10/12/2020
Data Release Frequency: Varies

NAPA COUNTY:

LUST NAPA: Sites With Reported Contamination

A listing of leaking underground storage tank sites located in Napa county.

Date of Government Version: 01/09/2017
Date Data Arrived at EDR: 01/11/2017
Date Made Active in Reports: 03/02/2017
Number of Days to Update: 50

Source: Napa County Department of Environmental Management
Telephone: 707-253-4269
Last EDR Contact: 08/19/2020
Next Scheduled EDR Contact: 12/07/2020
Data Release Frequency: No Update Planned

UST NAPA: Closed and Operating Underground Storage Tank Sites

Underground storage tank sites located in Napa county.

Date of Government Version: 09/05/2019
Date Data Arrived at EDR: 09/09/2019
Date Made Active in Reports: 10/31/2019
Number of Days to Update: 52

Source: Napa County Department of Environmental Management
Telephone: 707-253-4269
Last EDR Contact: 08/19/2020
Next Scheduled EDR Contact: 12/07/2020
Data Release Frequency: No Update Planned

NEVADA COUNTY:

CUPA NEVADA: CUPA Facility List

CUPA facility list.

Date of Government Version: 05/06/2020
Date Data Arrived at EDR: 05/07/2020
Date Made Active in Reports: 07/24/2020
Number of Days to Update: 78

Source: Community Development Agency
Telephone: 530-265-1467
Last EDR Contact: 07/21/2020
Next Scheduled EDR Contact: 11/09/2020
Data Release Frequency: Varies

ORANGE COUNTY:

IND_SITE ORANGE: List of Industrial Site Cleanups

Petroleum and non-petroleum spills.

Date of Government Version: 05/01/2020
Date Data Arrived at EDR: 05/08/2020
Date Made Active in Reports: 07/24/2020
Number of Days to Update: 77

Source: Health Care Agency
Telephone: 714-834-3446
Last EDR Contact: 07/31/2020
Next Scheduled EDR Contact: 11/16/2020
Data Release Frequency: Annually

LUST ORANGE: List of Underground Storage Tank Cleanups

Orange County Underground Storage Tank Cleanups (LUST).

Date of Government Version: 05/01/2020
Date Data Arrived at EDR: 05/08/2020
Date Made Active in Reports: 07/24/2020
Number of Days to Update: 77

Source: Health Care Agency
Telephone: 714-834-3446
Last EDR Contact: 07/31/2020
Next Scheduled EDR Contact: 11/16/2020
Data Release Frequency: Quarterly

GOVERNMENT RECORDS SEARCHED / DATA CURRENCY TRACKING

UST ORANGE: List of Underground Storage Tank Facilities

Orange County Underground Storage Tank Facilities (UST).

Date of Government Version: 05/01/2020
Date Data Arrived at EDR: 05/05/2020
Date Made Active in Reports: 07/17/2020
Number of Days to Update: 73

Source: Health Care Agency
Telephone: 714-834-3446
Last EDR Contact: 08/03/2020
Next Scheduled EDR Contact: 11/16/2020
Data Release Frequency: Quarterly

PLACER COUNTY:

MS PLACER: Master List of Facilities

List includes aboveground tanks, underground tanks and cleanup sites.

Date of Government Version: 06/08/2020
Date Data Arrived at EDR: 06/10/2020
Date Made Active in Reports: 08/24/2020
Number of Days to Update: 75

Source: Placer County Health and Human Services
Telephone: 530-745-2363
Last EDR Contact: 08/25/2020
Next Scheduled EDR Contact: 12/14/2020
Data Release Frequency: Semi-Annually

PLUMAS COUNTY:

CUPA PLUMAS: CUPA Facility List

Plumas County CUPA Program facilities.

Date of Government Version: 03/31/2019
Date Data Arrived at EDR: 04/23/2019
Date Made Active in Reports: 06/26/2019
Number of Days to Update: 64

Source: Plumas County Environmental Health
Telephone: 530-283-6355
Last EDR Contact: 07/14/2020
Next Scheduled EDR Contact: 11/02/2020
Data Release Frequency: Varies

RIVERSIDE COUNTY:

LUST RIVERSIDE: Listing of Underground Tank Cleanup Sites

Riverside County Underground Storage Tank Cleanup Sites (LUST).

Date of Government Version: 03/10/2020
Date Data Arrived at EDR: 03/11/2020
Date Made Active in Reports: 05/20/2020
Number of Days to Update: 70

Source: Department of Environmental Health
Telephone: 951-358-5055
Last EDR Contact: 06/10/2020
Next Scheduled EDR Contact: 09/28/2020
Data Release Frequency: Quarterly

UST RIVERSIDE: Underground Storage Tank Tank List

Underground storage tank sites located in Riverside county.

Date of Government Version: 03/10/2020
Date Data Arrived at EDR: 03/11/2020
Date Made Active in Reports: 05/20/2020
Number of Days to Update: 70

Source: Department of Environmental Health
Telephone: 951-358-5055
Last EDR Contact: 06/10/2020
Next Scheduled EDR Contact: 09/28/2020
Data Release Frequency: Quarterly

SACRAMENTO COUNTY:

CS SACRAMENTO: Toxic Site Clean-Up List

List of sites where unauthorized releases of potentially hazardous materials have occurred.

GOVERNMENT RECORDS SEARCHED / DATA CURRENCY TRACKING

Date of Government Version: 02/18/2020
Date Data Arrived at EDR: 03/31/2020
Date Made Active in Reports: 06/15/2020
Number of Days to Update: 76

Source: Sacramento County Environmental Management
Telephone: 916-875-8406
Last EDR Contact: 07/02/2020
Next Scheduled EDR Contact: 10/12/2020
Data Release Frequency: Quarterly

ML SACRAMENTO: Master Hazardous Materials Facility List

Any business that has hazardous materials on site - hazardous material storage sites, underground storage tanks, waste generators.

Date of Government Version: 02/24/2020
Date Data Arrived at EDR: 03/31/2020
Date Made Active in Reports: 06/17/2020
Number of Days to Update: 78

Source: Sacramento County Environmental Management
Telephone: 916-875-8406
Last EDR Contact: 07/02/2020
Next Scheduled EDR Contact: 10/12/2020
Data Release Frequency: Quarterly

SAN BENITO COUNTY:

CUPA SAN BENITO: CUPA Facility List

Cupa facility list

Date of Government Version: 04/24/2020
Date Data Arrived at EDR: 04/28/2020
Date Made Active in Reports: 07/13/2020
Number of Days to Update: 76

Source: San Benito County Environmental Health
Telephone: N/A
Last EDR Contact: 07/28/2020
Next Scheduled EDR Contact: 11/16/2020
Data Release Frequency: Varies

SAN BERNARDINO COUNTY:

PERMITS SAN BERNARDINO: Hazardous Material Permits

This listing includes underground storage tanks, medical waste handlers/generators, hazardous materials handlers, hazardous waste generators, and waste oil generators/handlers.

Date of Government Version: 02/25/2020
Date Data Arrived at EDR: 02/26/2020
Date Made Active in Reports: 05/07/2020
Number of Days to Update: 71

Source: San Bernardino County Fire Department Hazardous Materials Division
Telephone: 909-387-3041
Last EDR Contact: 07/28/2020
Next Scheduled EDR Contact: 11/16/2020
Data Release Frequency: Quarterly

SAN DIEGO COUNTY:

HMMD SAN DIEGO: Hazardous Materials Management Division Database

The database includes: HE58 - This report contains the business name, site address, business phone number, establishment 'H' permit number, type of permit, and the business status. HE17 - In addition to providing the same information provided in the HE58 listing, HE17 provides inspection dates, violations received by the establishment, hazardous waste generated, the quantity, method of storage, treatment/disposal of waste and the hauler, and information on underground storage tanks. Unauthorized Release List - Includes a summary of environmental contamination cases in San Diego County (underground tank cases, non-tank cases, groundwater contamination, and soil contamination are included.)

Date of Government Version: 06/01/2020
Date Data Arrived at EDR: 06/02/2020
Date Made Active in Reports: 08/14/2020
Number of Days to Update: 73

Source: Hazardous Materials Management Division
Telephone: 619-338-2268
Last EDR Contact: 06/02/2020
Next Scheduled EDR Contact: 09/14/2020
Data Release Frequency: Quarterly

GOVERNMENT RECORDS SEARCHED / DATA CURRENCY TRACKING

LF SAN DIEGO: Solid Waste Facilities

San Diego County Solid Waste Facilities.

Date of Government Version: 04/18/2018
Date Data Arrived at EDR: 04/24/2018
Date Made Active in Reports: 06/19/2018
Number of Days to Update: 56

Source: Department of Health Services
Telephone: 619-338-2209
Last EDR Contact: 07/14/2020
Next Scheduled EDR Contact: 11/02/2020
Data Release Frequency: Varies

SAN DIEGO CO LOP: Local Oversight Program Listing

A listing of all LOP release sites that are or were under the County of San Diego's jurisdiction. Included are closed or transferred cases, open cases, and cases that did not have a case type indicated. The cases without a case type are mostly complaints; however, some of them could be LOP cases.

Date of Government Version: 04/09/2020
Date Data Arrived at EDR: 04/10/2020
Date Made Active in Reports: 06/26/2020
Number of Days to Update: 77

Source: Department of Environmental Health
Telephone: 858-505-6874
Last EDR Contact: 07/14/2020
Next Scheduled EDR Contact: 11/02/2020
Data Release Frequency: Varies

SAN DIEGO CO SAM: Environmental Case Listing

The listing contains all underground tank release cases and projects pertaining to properties contaminated with hazardous substances that are actively under review by the Site Assessment and Mitigation Program.

Date of Government Version: 03/23/2010
Date Data Arrived at EDR: 06/15/2010
Date Made Active in Reports: 07/09/2010
Number of Days to Update: 24

Source: San Diego County Department of Environmental Health
Telephone: 619-338-2371
Last EDR Contact: 08/25/2020
Next Scheduled EDR Contact: 12/14/2020
Data Release Frequency: No Update Planned

SAN FRANCISCO COUNTY:

LUST SAN FRANCISCO: Local Oversight Facilities

A listing of leaking underground storage tank sites located in San Francisco county.

Date of Government Version: 09/19/2008
Date Data Arrived at EDR: 09/19/2008
Date Made Active in Reports: 09/29/2008
Number of Days to Update: 10

Source: Department Of Public Health San Francisco County
Telephone: 415-252-3920
Last EDR Contact: 07/28/2020
Next Scheduled EDR Contact: 11/16/2020
Data Release Frequency: No Update Planned

UST SAN FRANCISCO: Underground Storage Tank Information

Underground storage tank sites located in San Francisco county.

Date of Government Version: 05/04/2020
Date Data Arrived at EDR: 05/06/2020
Date Made Active in Reports: 07/17/2020
Number of Days to Update: 72

Source: Department of Public Health
Telephone: 415-252-3920
Last EDR Contact: 07/28/2020
Next Scheduled EDR Contact: 11/16/2020
Data Release Frequency: Quarterly

SAN JOAQUIN COUNTY:

UST SAN JOAQUIN: San Joaquin Co. UST

A listing of underground storage tank locations in San Joaquin county.

Date of Government Version: 06/22/2018
Date Data Arrived at EDR: 06/26/2018
Date Made Active in Reports: 07/11/2018
Number of Days to Update: 15

Source: Environmental Health Department
Telephone: N/A
Last EDR Contact: 06/10/2020
Next Scheduled EDR Contact: 09/28/2020
Data Release Frequency: Semi-Annually

SAN LUIS OBISPO COUNTY:

GOVERNMENT RECORDS SEARCHED / DATA CURRENCY TRACKING

CUPA SAN LUIS OBISPO: CUPA Facility List Cupa Facility List.

Date of Government Version: 05/08/2020
Date Data Arrived at EDR: 05/08/2020
Date Made Active in Reports: 08/03/2020
Number of Days to Update: 87

Source: San Luis Obispo County Public Health Department
Telephone: 805-781-5596
Last EDR Contact: 08/11/2020
Next Scheduled EDR Contact: 11/30/2020
Data Release Frequency: Varies

SAN MATEO COUNTY:

BI SAN MATEO: Business Inventory

List includes Hazardous Materials Business Plan, hazardous waste generators, and underground storage tanks.

Date of Government Version: 02/20/2020
Date Data Arrived at EDR: 02/20/2020
Date Made Active in Reports: 04/24/2020
Number of Days to Update: 64

Source: San Mateo County Environmental Health Services Division
Telephone: 650-363-1921
Last EDR Contact: 06/12/2020
Next Scheduled EDR Contact: 09/21/2020
Data Release Frequency: Annually

LUST SAN MATEO: Fuel Leak List

A listing of leaking underground storage tank sites located in San Mateo county.

Date of Government Version: 03/29/2019
Date Data Arrived at EDR: 03/29/2019
Date Made Active in Reports: 05/29/2019
Number of Days to Update: 61

Source: San Mateo County Environmental Health Services Division
Telephone: 650-363-1921
Last EDR Contact: 06/03/2020
Next Scheduled EDR Contact: 09/21/2020
Data Release Frequency: Semi-Annually

SANTA BARBARA COUNTY:

CUPA SANTA BARBARA: CUPA Facility Listing

CUPA Program Listing from the Environmental Health Services division.

Date of Government Version: 09/08/2011
Date Data Arrived at EDR: 09/09/2011
Date Made Active in Reports: 10/07/2011
Number of Days to Update: 28

Source: Santa Barbara County Public Health Department
Telephone: 805-686-8167
Last EDR Contact: 08/11/2020
Next Scheduled EDR Contact: 11/30/2020
Data Release Frequency: No Update Planned

SANTA CLARA COUNTY:

CUPA SANTA CLARA: Cupa Facility List

Cupa facility list

Date of Government Version: 05/08/2020
Date Data Arrived at EDR: 05/12/2020
Date Made Active in Reports: 07/27/2020
Number of Days to Update: 76

Source: Department of Environmental Health
Telephone: 408-918-1973
Last EDR Contact: 08/11/2020
Next Scheduled EDR Contact: 11/30/2020
Data Release Frequency: Varies

HIST LUST SANTA CLARA: HIST LUST - Fuel Leak Site Activity Report

A listing of open and closed leaking underground storage tanks. This listing is no longer updated by the county. Leaking underground storage tanks are now handled by the Department of Environmental Health.

Date of Government Version: 03/29/2005
Date Data Arrived at EDR: 03/30/2005
Date Made Active in Reports: 04/21/2005
Number of Days to Update: 22

Source: Santa Clara Valley Water District
Telephone: 408-265-2600
Last EDR Contact: 03/23/2009
Next Scheduled EDR Contact: 06/22/2009
Data Release Frequency: No Update Planned

GOVERNMENT RECORDS SEARCHED / DATA CURRENCY TRACKING

LUST SANTA CLARA: LOP Listing

A listing of leaking underground storage tanks located in Santa Clara county.

Date of Government Version: 03/03/2014
Date Data Arrived at EDR: 03/05/2014
Date Made Active in Reports: 03/18/2014
Number of Days to Update: 13

Source: Department of Environmental Health
Telephone: 408-918-3417
Last EDR Contact: 08/19/2020
Next Scheduled EDR Contact: 12/07/2020
Data Release Frequency: No Update Planned

SAN JOSE HAZMAT: Hazardous Material Facilities

Hazardous material facilities, including underground storage tank sites.

Date of Government Version: 04/22/2020
Date Data Arrived at EDR: 04/24/2020
Date Made Active in Reports: 05/07/2020
Number of Days to Update: 13

Source: City of San Jose Fire Department
Telephone: 408-535-7694
Last EDR Contact: 07/28/2020
Next Scheduled EDR Contact: 11/16/2020
Data Release Frequency: Annually

SANTA CRUZ COUNTY:

CUPA SANTA CRUZ: CUPA Facility List

CUPA facility listing.

Date of Government Version: 01/21/2017
Date Data Arrived at EDR: 02/22/2017
Date Made Active in Reports: 05/23/2017
Number of Days to Update: 90

Source: Santa Cruz County Environmental Health
Telephone: 831-464-2761
Last EDR Contact: 08/11/2020
Next Scheduled EDR Contact: 11/30/2020
Data Release Frequency: Varies

SHASTA COUNTY:

CUPA SHASTA: CUPA Facility List

Cupa Facility List.

Date of Government Version: 06/15/2017
Date Data Arrived at EDR: 06/19/2017
Date Made Active in Reports: 08/09/2017
Number of Days to Update: 51

Source: Shasta County Department of Resource Management
Telephone: 530-225-5789
Last EDR Contact: 08/11/2020
Next Scheduled EDR Contact: 11/30/2020
Data Release Frequency: Varies

SOLANO COUNTY:

LUST SOLANO: Leaking Underground Storage Tanks

A listing of leaking underground storage tank sites located in Solano county.

Date of Government Version: 06/04/2019
Date Data Arrived at EDR: 06/06/2019
Date Made Active in Reports: 08/13/2019
Number of Days to Update: 68

Source: Solano County Department of Environmental Management
Telephone: 707-784-6770
Last EDR Contact: 08/25/2020
Next Scheduled EDR Contact: 12/14/2020
Data Release Frequency: Quarterly

UST SOLANO: Underground Storage Tanks

Underground storage tank sites located in Solano county.

Date of Government Version: 03/02/2020
Date Data Arrived at EDR: 03/04/2020
Date Made Active in Reports: 05/14/2020
Number of Days to Update: 71

Source: Solano County Department of Environmental Management
Telephone: 707-784-6770
Last EDR Contact: 08/25/2020
Next Scheduled EDR Contact: 12/14/2020
Data Release Frequency: Quarterly

SONOMA COUNTY:

GOVERNMENT RECORDS SEARCHED / DATA CURRENCY TRACKING

CUPA SONOMA: Cupa Facility List Cupa Facility list

Date of Government Version: 02/25/2020
Date Data Arrived at EDR: 02/26/2020
Date Made Active in Reports: 03/11/2020
Number of Days to Update: 14

Source: County of Sonoma Fire & Emergency Services Department
Telephone: 707-565-1174
Last EDR Contact: 06/30/2020
Next Scheduled EDR Contact: 10/05/2020
Data Release Frequency: Varies

LUST SONOMA: Leaking Underground Storage Tank Sites

A listing of leaking underground storage tank sites located in Sonoma county.

Date of Government Version: 04/03/2020
Date Data Arrived at EDR: 04/08/2020
Date Made Active in Reports: 06/26/2020
Number of Days to Update: 79

Source: Department of Health Services
Telephone: 707-565-6565
Last EDR Contact: 06/17/2020
Next Scheduled EDR Contact: 10/05/2020
Data Release Frequency: Quarterly

STANISLAUS COUNTY:

CUPA STANISLAUS: CUPA Facility List Cupa facility list

Date of Government Version: 02/04/2020
Date Data Arrived at EDR: 02/05/2020
Date Made Active in Reports: 04/15/2020
Number of Days to Update: 70

Source: Stanislaus County Department of Environmental Protection
Telephone: 209-525-6751
Last EDR Contact: 07/06/2020
Next Scheduled EDR Contact: 10/26/2020
Data Release Frequency: Varies

SUTTER COUNTY:

UST SUTTER: Underground Storage Tanks

Underground storage tank sites located in Sutter county.

Date of Government Version: 05/26/2020
Date Data Arrived at EDR: 05/28/2020
Date Made Active in Reports: 08/13/2020
Number of Days to Update: 77

Source: Sutter County Environmental Health Services
Telephone: 530-822-7500
Last EDR Contact: 08/25/2020
Next Scheduled EDR Contact: 12/14/2020
Data Release Frequency: Semi-Annually

TEHAMA COUNTY:

CUPA TEHAMA: CUPA Facility List Cupa facilities

Date of Government Version: 05/18/2020
Date Data Arrived at EDR: 05/19/2020
Date Made Active in Reports: 07/31/2020
Number of Days to Update: 73

Source: Tehama County Department of Environmental Health
Telephone: 530-527-8020
Last EDR Contact: 08/11/2020
Next Scheduled EDR Contact: 11/16/2020
Data Release Frequency: Varies

TRINITY COUNTY:

CUPA TRINITY: CUPA Facility List Cupa facility list

GOVERNMENT RECORDS SEARCHED / DATA CURRENCY TRACKING

Date of Government Version: 04/09/2020
Date Data Arrived at EDR: 04/10/2020
Date Made Active in Reports: 07/01/2020
Number of Days to Update: 82

Source: Department of Toxic Substances Control
Telephone: 760-352-0381
Last EDR Contact: 07/14/2020
Next Scheduled EDR Contact: 11/02/2020
Data Release Frequency: Varies

TULARE COUNTY:

CUPA TULARE: CUPA Facility List Cupa program facilities

Date of Government Version: 05/14/2020
Date Data Arrived at EDR: 05/15/2020
Date Made Active in Reports: 07/27/2020
Number of Days to Update: 73

Source: Tulare County Environmental Health Services Division
Telephone: 559-624-7400
Last EDR Contact: 08/06/2020
Next Scheduled EDR Contact: 11/16/2020
Data Release Frequency: Varies

TUOLUMNE COUNTY:

CUPA TUOLUMNE: CUPA Facility List Cupa facility list

Date of Government Version: 04/23/2018
Date Data Arrived at EDR: 04/25/2018
Date Made Active in Reports: 06/25/2018
Number of Days to Update: 61

Source: Divison of Environmental Health
Telephone: 209-533-5633
Last EDR Contact: 07/14/2020
Next Scheduled EDR Contact: 11/02/2020
Data Release Frequency: Varies

VENTURA COUNTY:

BWT VENTURA: Business Plan, Hazardous Waste Producers, and Operating Underground Tanks

The BWT list indicates by site address whether the Environmental Health Division has Business Plan (B), Waste Producer (W), and/or Underground Tank (T) information.

Date of Government Version: 03/26/2020
Date Data Arrived at EDR: 04/23/2020
Date Made Active in Reports: 07/09/2020
Number of Days to Update: 77

Source: Ventura County Environmental Health Division
Telephone: 805-654-2813
Last EDR Contact: 07/20/2020
Next Scheduled EDR Contact: 11/02/2020
Data Release Frequency: Quarterly

LF VENTURA: Inventory of Illegal Abandoned and Inactive Sites

Ventura County Inventory of Closed, Illegal Abandoned, and Inactive Sites.

Date of Government Version: 12/01/2011
Date Data Arrived at EDR: 12/01/2011
Date Made Active in Reports: 01/19/2012
Number of Days to Update: 49

Source: Environmental Health Division
Telephone: 805-654-2813
Last EDR Contact: 06/24/2020
Next Scheduled EDR Contact: 10/12/2020
Data Release Frequency: No Update Planned

LUST VENTURA: Listing of Underground Tank Cleanup Sites

Ventura County Underground Storage Tank Cleanup Sites (LUST).

Date of Government Version: 05/29/2008
Date Data Arrived at EDR: 06/24/2008
Date Made Active in Reports: 07/31/2008
Number of Days to Update: 37

Source: Environmental Health Division
Telephone: 805-654-2813
Last EDR Contact: 08/04/2020
Next Scheduled EDR Contact: 11/23/2020
Data Release Frequency: No Update Planned

GOVERNMENT RECORDS SEARCHED / DATA CURRENCY TRACKING

MED WASTE VENTURA: Medical Waste Program List

To protect public health and safety and the environment from potential exposure to disease causing agents, the Environmental Health Division Medical Waste Program regulates the generation, handling, storage, treatment and disposal of medical waste throughout the County.

Date of Government Version: 03/26/2020	Source: Ventura County Resource Management Agency
Date Data Arrived at EDR: 04/23/2020	Telephone: 805-654-2813
Date Made Active in Reports: 07/09/2020	Last EDR Contact: 07/20/2020
Number of Days to Update: 77	Next Scheduled EDR Contact: 11/02/2020
	Data Release Frequency: Quarterly

UST VENTURA: Underground Tank Closed Sites List

Ventura County Operating Underground Storage Tank Sites (UST)/Underground Tank Closed Sites List.

Date of Government Version: 05/26/2020	Source: Environmental Health Division
Date Data Arrived at EDR: 06/09/2020	Telephone: 805-654-2813
Date Made Active in Reports: 08/20/2020	Last EDR Contact: 06/09/2020
Number of Days to Update: 72	Next Scheduled EDR Contact: 09/21/2020
	Data Release Frequency: Quarterly

YOLO COUNTY:

UST YOLO: Underground Storage Tank Comprehensive Facility Report

Underground storage tank sites located in Yolo county.

Date of Government Version: 03/23/2020	Source: Yolo County Department of Health
Date Data Arrived at EDR: 04/01/2020	Telephone: 530-666-8646
Date Made Active in Reports: 06/17/2020	Last EDR Contact: 06/24/2020
Number of Days to Update: 77	Next Scheduled EDR Contact: 10/12/2020
	Data Release Frequency: Annually

YUBA COUNTY:

CUPA YUBA: CUPA Facility List

CUPA facility listing for Yuba County.

Date of Government Version: 04/27/2020	Source: Yuba County Environmental Health Department
Date Data Arrived at EDR: 04/29/2020	Telephone: 530-749-7523
Date Made Active in Reports: 07/17/2020	Last EDR Contact: 08/04/2020
Number of Days to Update: 79	Next Scheduled EDR Contact: 11/09/2020
	Data Release Frequency: Varies

OTHER DATABASE(S)

Depending on the geographic area covered by this report, the data provided in these specialty databases may or may not be complete. For example, the existence of wetlands information data in a specific report does not mean that all wetlands in the area covered by the report are included. Moreover, the absence of any reported wetlands information does not necessarily mean that wetlands do not exist in the area covered by the report.

CT MANIFEST: Hazardous Waste Manifest Data

Facility and manifest data. Manifest is a document that lists and tracks hazardous waste from the generator through transporters to a tsd facility.

Date of Government Version: 05/12/2020	Source: Department of Energy & Environmental Protection
Date Data Arrived at EDR: 05/12/2020	Telephone: 860-424-3375
Date Made Active in Reports: 07/27/2020	Last EDR Contact: 08/10/2020
Number of Days to Update: 76	Next Scheduled EDR Contact: 11/23/2020
	Data Release Frequency: No Update Planned

GOVERNMENT RECORDS SEARCHED / DATA CURRENCY TRACKING

NJ MANIFEST: Manifest Information

Hazardous waste manifest information.

Date of Government Version: 12/31/2018
Date Data Arrived at EDR: 04/10/2019
Date Made Active in Reports: 05/16/2019
Number of Days to Update: 36

Source: Department of Environmental Protection
Telephone: N/A
Last EDR Contact: 07/09/2020
Next Scheduled EDR Contact: 10/19/2020
Data Release Frequency: Annually

NY MANIFEST: Facility and Manifest Data

Manifest is a document that lists and tracks hazardous waste from the generator through transporters to a TSD facility.

Date of Government Version: 01/01/2019
Date Data Arrived at EDR: 04/29/2020
Date Made Active in Reports: 07/10/2020
Number of Days to Update: 72

Source: Department of Environmental Conservation
Telephone: 518-402-8651
Last EDR Contact: 07/31/2020
Next Scheduled EDR Contact: 11/09/2020
Data Release Frequency: Quarterly

PA MANIFEST: Manifest Information

Hazardous waste manifest information.

Date of Government Version: 06/30/2018
Date Data Arrived at EDR: 07/19/2019
Date Made Active in Reports: 09/10/2019
Number of Days to Update: 53

Source: Department of Environmental Protection
Telephone: 717-783-8990
Last EDR Contact: 07/09/2020
Next Scheduled EDR Contact: 10/26/2020
Data Release Frequency: Annually

RI MANIFEST: Manifest information

Hazardous waste manifest information

Date of Government Version: 12/31/2018
Date Data Arrived at EDR: 10/02/2019
Date Made Active in Reports: 12/10/2019
Number of Days to Update: 69

Source: Department of Environmental Management
Telephone: 401-222-2797
Last EDR Contact: 08/11/2020
Next Scheduled EDR Contact: 11/30/2020
Data Release Frequency: Annually

WI MANIFEST: Manifest Information

Hazardous waste manifest information.

Date of Government Version: 05/31/2018
Date Data Arrived at EDR: 06/19/2019
Date Made Active in Reports: 09/03/2019
Number of Days to Update: 76

Source: Department of Natural Resources
Telephone: N/A
Last EDR Contact: 06/04/2020
Next Scheduled EDR Contact: 09/21/2020
Data Release Frequency: Annually

Oil/Gas Pipelines

Source: Endeavor Business Media

Petroleum Bundle (Crude Oil, Refined Products, Petrochemicals, Gas Liquids (LPG/NGL), and Specialty Gases (Miscellaneous)) N = Natural Gas Bundle (Natural Gas, Gas Liquids (LPG/NGL), and Specialty Gases (Miscellaneous)). This map includes information copyrighted by Endeavor Business Media. This information is provided on a best effort basis and Endeavor Business Media does not guarantee its accuracy nor warrant its fitness for any particular purpose. Such information has been reprinted with the permission of Endeavor Business Media.

Electric Power Transmission Line Data

Source: Endeavor Business Media

This map includes information copyrighted by Endeavor Business Media. This information is provided on a best effort basis and Endeavor Business Media does not guarantee its accuracy nor warrant its fitness for any particular purpose. Such information has been reprinted with the permission of Endeavor Business Media.

Sensitive Receptors: There are individuals deemed sensitive receptors due to their fragile immune systems and special sensitivity to environmental discharges. These sensitive receptors typically include the elderly, the sick, and children. While the location of all sensitive receptors cannot be determined, EDR indicates those buildings and facilities - schools, daycares, hospitals, medical centers, and nursing homes - where individuals who are sensitive receptors are likely to be located.

GOVERNMENT RECORDS SEARCHED / DATA CURRENCY TRACKING

AHA Hospitals:

Source: American Hospital Association, Inc.

Telephone: 312-280-5991

The database includes a listing of hospitals based on the American Hospital Association's annual survey of hospitals.

Medical Centers: Provider of Services Listing

Source: Centers for Medicare & Medicaid Services

Telephone: 410-786-3000

A listing of hospitals with Medicare provider number, produced by Centers of Medicare & Medicaid Services, a federal agency within the U.S. Department of Health and Human Services.

Nursing Homes

Source: National Institutes of Health

Telephone: 301-594-6248

Information on Medicare and Medicaid certified nursing homes in the United States.

Public Schools

Source: National Center for Education Statistics

Telephone: 202-502-7300

The National Center for Education Statistics' primary database on elementary and secondary public education in the United States. It is a comprehensive, annual, national statistical database of all public elementary and secondary schools and school districts, which contains data that are comparable across all states.

Private Schools

Source: National Center for Education Statistics

Telephone: 202-502-7300

The National Center for Education Statistics' primary database on private school locations in the United States.

Daycare Centers: Licensed Facilities

Source: Department of Social Services

Telephone: 916-657-4041

Flood Zone Data: This data was obtained from the Federal Emergency Management Agency (FEMA). It depicts 100-year and 500-year flood zones as defined by FEMA. It includes the National Flood Hazard Layer (NFHL) which incorporates Flood Insurance Rate Map (FIRM) data and Q3 data from FEMA in areas not covered by NFHL.

Source: FEMA

Telephone: 877-336-2627

Date of Government Version: 2003, 2015

NWI: National Wetlands Inventory. This data, available in select counties across the country, was obtained by EDR in 2002, 2005 and 2010 from the U.S. Fish and Wildlife Service.

State Wetlands Data: Wetland Inventory

Source: Department of Fish and Wildlife

Telephone: 916-445-0411

STREET AND ADDRESS INFORMATION

© 2015 TomTom North America, Inc. All rights reserved. This material is proprietary and the subject of copyright protection and other intellectual property rights owned by or licensed to Tele Atlas North America, Inc. The use of this material is subject to the terms of a license agreement. You will be held liable for any unauthorized copying or disclosure of this material.

APPENDIX F

PC ORIGINAL PKG

GEOTRACKER

calexico, ca

Map Address

Sites and Facilities - INFO

Cleanup Sites

- LUST Cleanup Sites
- Cleanup Program Sites
- Military Cleanup Sites
 - Military Cleanup Sites
 - Military Privatized Sites
 - Military UST Sites
- DTSC Cleanup Sites

Permitted Facilities

- Waste Discharge Requirements (WDR) Sites
- Permitted USTs - INFO
- DTSC Hazardous Waste Sites
- Land Disposal Sites
- Irrigated Lands Regulatory Program Sites
- Oil / Gas Sites
- Confined Animal Sites

Other Sites

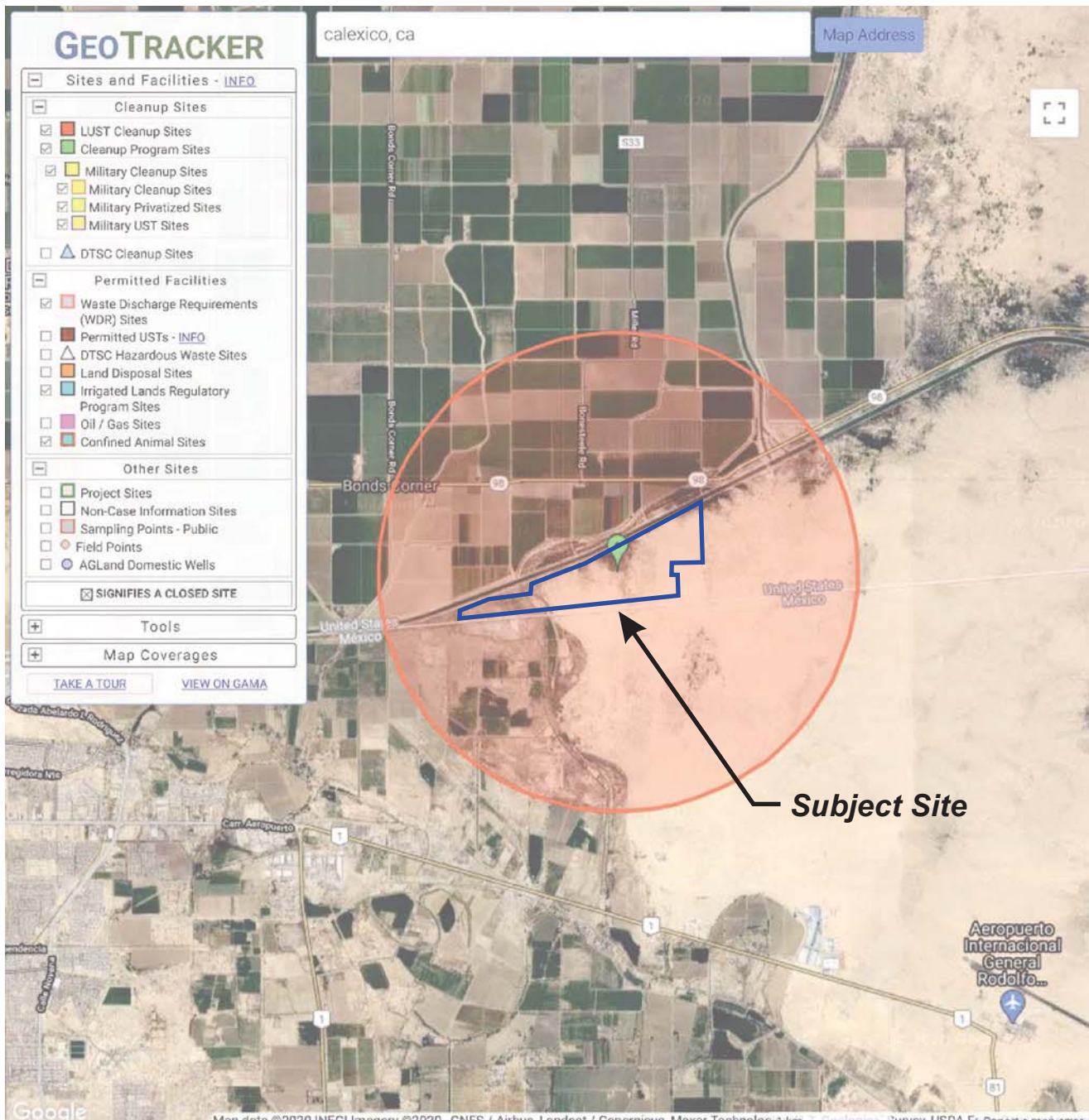
- Project Sites
- Non-Case Information Sites
- Sampling Points - Public
- Field Points
- AGLand Domestic Wells

SIGNIFIES A CLOSED SITE

Tools

Map Coverages

[TAKE A TOUR](#) [VIEW ON GAMA](#)



Subject Site

SITES FOUND IN SEARCH RADIUS 0 SITES LISTED [EXPORT THIS LIST TO EXCEL](#)

SITE NAME	GLOBAL ID	STATUS	ADDRESS	CITY
---------------------------	---------------------------	------------------------	-------------------------	----------------------



Project No.: GS2015

Geotracker Map

Plate
15

PC ORIGINAL PKG

ENVIROSTOR

calexico, ca

Map Address

Sites and Facilities

Cleanup Sites

- Federal Superfund
- State Response
- Voluntary Cleanup
- School Cleanup
- Evaluation
- School Investigation
- Military Evaluation
- Tiered Permit
- Corrective Action
- Field Points

STATUS

All Statuses

Permitted Sites

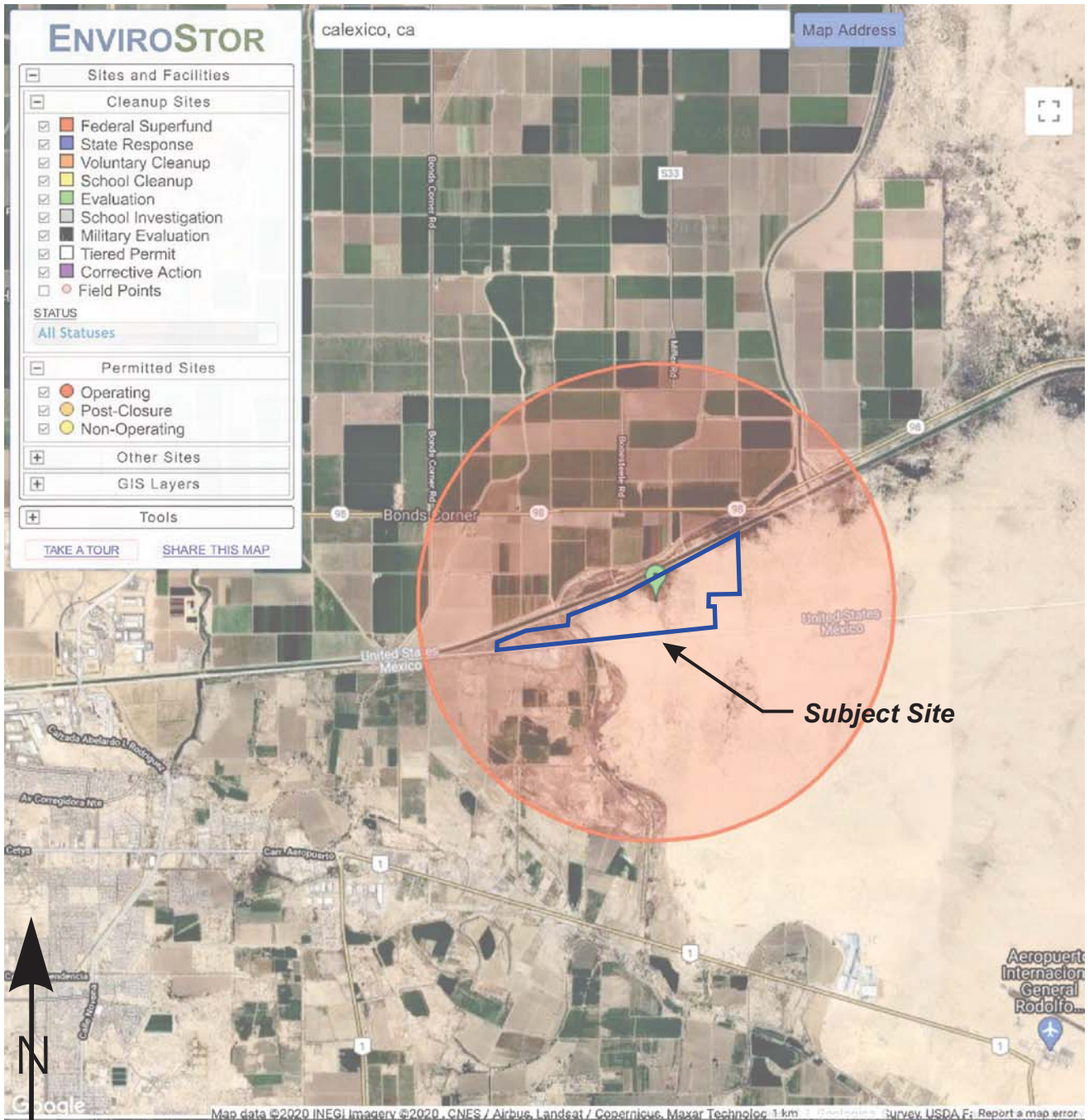
- Operating
- Post-Closure
- Non-Operating

Other Sites

GIS Layers

Tools

[TAKE A TOUR](#) [SHARE THIS MAP](#)



SITES FOUND IN SEARCH RADIUS: 0 SITES LISTED [EXPORT THIS LIST TO EXCEL](#)

PROJECT NAME	STATUS	PROJECT TYPE	ADDRESS	CITY



Project No.: GS2015

Envirostor Map

Plate
16

PC ORIGINAL PKG

APPENDIX G

PC ORIGINAL PKG

Issuing Policies of Fidelity National Title Insurance Company

Title Officer: Mitch LaRiva
Escrow Officer: Major Accounts OAC

Order No.: 997-30053824-ML6

TO:
ZGlobal
604 Sutter Street, Suite 250
Folsom, CA 95630

ATTN: **Jamie Nichole Nagel**
YOUR REFERENCE: **059-300-015 SLATER**

PROPERTY ADDRESS: APN'S #059-300-015-000, 059-300-017-000 and 059-290-010-000, County of Imperial, CA

PRELIMINARY REPORT

*In response to the application for a policy of title insurance referenced herein, **Fidelity National Title Company** hereby reports that it is prepared to issue, or cause to be issued, as of the date hereof, a policy or policies of title insurance describing the land and the estate or interest therein hereinafter set forth, insuring against loss which may be sustained by reason of any defect, lien or encumbrance not shown or referred to as an exception herein or not excluded from coverage pursuant to the printed Schedules, Conditions and Stipulations or Conditions of said policy forms.*

The printed Exceptions and Exclusions from the coverage and Limitations on Covered Risks of said policy or policies are set forth in Attachment One. The policy to be issued may contain an arbitration clause. When the Amount of Insurance is less than that set forth in the arbitration clause, all arbitrable matters shall be arbitrated at the option of either the Company or the Insured as the exclusive remedy of the parties. Limitations on Covered Risks applicable to the CLTA and ALTA Homeowner's Policies of Title Insurance which establish a Deductible Amount and a Maximum Dollar Limit of Liability for certain coverages are also set forth in Attachment One. Copies of the policy forms should be read. They are available from the office which issued this report.

This report (and any supplements or amendments hereto) is issued solely for the purpose of facilitating the issuance of a policy of title insurance and no liability is assumed hereby. If it is desired that liability be assumed prior to the issuance of a policy of title insurance, a Binder or Commitment should be requested.

The policy(s) of title insurance to be issued hereunder will be policy(s) of Fidelity National Title Insurance Company, a Florida Corporation.

Please read the exceptions shown or referred to herein and the exceptions and exclusions set forth in Attachment One of this report carefully. The exceptions and exclusions are meant to provide you with notice of matters which are not covered under the terms of the title insurance policy and should be carefully considered.

It is important to note that this preliminary report is not a written representation as to the condition of title and may not list all liens, defects and encumbrances affecting title to the land.

Countersigned by:



Authorized Signature

PRELIMINARY REPORT

EFFECTIVE DATE: August 31, 2020 at 7:30 a.m.

ORDER NO.: 997-30053824-ML6

The form of policy or policies of title insurance contemplated by this report is:

ALTA Standard Owners Policy (6-17-06)

1. THE ESTATE OR INTEREST IN THE LAND HEREINAFTER DESCRIBED OR REFERRED TO COVERED BY THIS REPORT IS:

A FEE

2. TITLE TO SAID ESTATE OR INTEREST AT THE DATE HEREOF IS [VESTED IN:](#)

TAMMY CHERI SLATER and JIMMIE R. DOYLE, Successor Co-Trustees of the EXEMPTION TRUST under the DOYLE FAMILY 2010 TRUST, dated August 13, 2010, as to an undivided 92.9% interest and TAMMY CHERI SLATER and JIMMIE R. DOYLE, Successor Co-Trustees of the SURVIVOR'S TRUST under the DOYLE FAMILY 2010 TRUST, dated August 13, 2010, as to an undivided 7.1% interest, subject to Item No. 24 of Exceptions and Item No's. 1 and 2 of Requirements

3. THE LAND REFERRED TO IN THIS REPORT IS DESCRIBED AS FOLLOWS:

See Exhibit A attached hereto and made a part hereof.

EXHIBIT A LEGAL DESCRIPTION

THE LAND REFERRED TO HEREIN BELOW IS SITUATED IN THE UNINCORPORATED AREA OF COUNTY OF IMPERIAL, COUNTY OF IMPERIAL, STATE OF CALIFORNIA, AND IS DESCRIBED AS FOLLOWS:

PARCEL 1:

THOSE PORTIONS OF LOTS 13, 20 AND 21, AND THE SOUTHWEST QUARTER OF THE SOUTHEAST QUARTER OF SECTION 10, LYING SOUTH OF THE ALL-AMERICAN CANAL, TOWNSHIP 17 SOUTH, RANGE 16 EAST, SAN BERNARDINO MERIDIAN, IN AN UNINCORPORATED AREA OF THE COUNTY OF IMPERIAL, STATE OF CALIFORNIA, ACCORDING TO THE OFFICIAL PLAT THEREOF.

PORTION OF [APN: 059-300-015-000](#)

PARCEL 2:

LOTS 11, 13, 15 AND THE NORTH HALF OF THE SOUTHEAST QUARTER OF SECTION 11, TOWNSHIP 17 SOUTH, RANGE 16 EAST, SAN BERNARDINO MERIDIAN, IN AN UNINCORPORATED AREA OF THE COUNTY OF IMPERIAL, STATE OF CALIFORNIA, ACCORDING TO THE OFFICIAL PLAT THEREOF.

PORTION OF [APN: 059-300-015-000](#)

PARCEL 3:

THOSE PORTIONS OF LOTS 6, 7 AND 10, AND THE NORTHEAST QUARTER OF SECTION 11, LYING SOUTH OF THE ALL-AMERICAN CANAL, TOWNSHIP 17 SOUTH, RANGE 16 EAST, SAN BERNARDINO MERIDIAN, IN AN UNINCORPORATED AREA OF THE COUNTY OF IMPERIAL, STATE OF CALIFORNIA, ACCORDING TO THE OFFICIAL PLAT THEREOF.

PORTION OF [APN: 059-300-015-000](#)

PARCEL 4:

TRACT 41, TOWNSHIP 17 SOUTH, RANGE 16 EAST, SAN BERNARDINO MERIDIAN, IN AN UNINCORPORATED AREA OF THE COUNTY OF IMPERIAL, STATE OF CALIFORNIA, ACCORDING TO THE OFFICIAL PLAT THEREOF.

EXCEPTING THEREFROM ONE-HALF OF ALL STEAM, MINERALS, OILS, GAS, WATER, CARBONS AND HYDROCARBONS ON OR UNDER THE HEREIN DESCRIBED PROPERTY, AS RESERVED BY NATALIE KAPLAN BY DEED RECORDED APRIL 5, 1979 AS DOCUMENT NO. 3 IN [BOOK 1431, PAGE 1454](#), OF OFFICIAL RECORDS.

ALSO EXCEPTING THEREFROM THE SOUTH 60 FEET THEREOF AS TAKEN BY THE UNITED STATES OF AMERICA IN DECLARATION OF TAKING RECORDED AUGUST 8, 2008 AS [DOCUMENT NO. 2008-023038, OF OFFICIAL RECORDS](#).

[APN: 059-300-017-000](#)

EXHIBIT A
(Continued)

PARCEL 5:

LOTS 2, 3, 4 AND 7, SECTION 15 AND THAT PORTION OF LOT 3, SECTION 16, LYING SOUTHERLY OF THE ALL- AMERICAN CANAL, ALL IN TOWNSHIP 17 SOUTH, RANGE 16 EAST, SAN BERNARDINO MERIDIAN, IN AN UNINCORPORATED AREA OF THE COUNTY OF IMPERIAL, STATE OF CALIFORNIA, ACCORDING TO THE OFFICIAL PLAT THEREOF.

EXCEPTING THEREFROM ANY PORTIONS THEREOF LYING WITHIN THE PUBLIC RESERVE, BEING THE SOUTH 60 FEET, LYING ADJACENT TO THE INTERNATIONAL BORDER BETWEEN THE UNITED STATES AND MEXICO, AS SET OUT BY PRESIDENTIAL PROCLAMATION DATED MAY 27, 1907 (35 STATS, 2186).

[APN: 059-290-010-000](#)

EXCEPTIONS

AT THE DATE HEREOF, ITEMS TO BE CONSIDERED AND EXCEPTIONS TO COVERAGE IN ADDITION TO THE PRINTED EXCEPTIONS AND EXCLUSIONS IN SAID POLICY FORM WOULD BE AS FOLLOWS:

- A. Property taxes, including any personal property taxes and any assessments collected with taxes, are as follows:

Tax Identification No.: 059-300-015-000
Fiscal Year: 2020-2021
1st Installment: \$1,369.48, OPEN (Delinquent after December 10)
Penalty: \$136.94
2nd Installment: \$1,369.48, OPEN (Delinquent after April 10)
Penalty and Cost: \$146.94
Homeowners Exemption: \$0.00
Code Area: 068-012

Affects: Parcels 1, 2 and 3.

Property taxes, including any personal property taxes and any assessments collected with taxes, are as follows:

Tax Identification No.: 059-300-017-000
Fiscal Year: 2020-2021
1st Installment: \$374.67, OPEN (Delinquent after December 10)
Penalty: \$37.46
2nd Installment: \$374.67, OPEN (Delinquent after April 10)
Penalty and Cost: \$47.46
Homeowners Exemption: \$0.00
Code Area: 068-012

Affects: Parcel 4.

Property taxes, including any personal property taxes and any assessments collected with taxes, are as follows:

Tax Identification No.: 059-290-010-000
Fiscal Year: 2020-2021
1st Installment: \$204.52, OPEN (Delinquent after December 10)
Penalty: \$20.45
2nd Installment: \$204.52, OPEN (Delinquent after April 10)
Penalty and Cost: \$30.45
Homeowners Exemption: \$0.00
Code Area: 068-012

Affects: Parcel 5.

- B. Taxes and assessments levied by the Imperial Irrigation District.
- C. The lien of supplemental or escaped assessments of property taxes, if any, made pursuant to the provisions of Chapter 3.5 (commencing with Section 75) or Part 2, Chapter 3, Articles 3 and 4, respectively, of the Revenue and Taxation Code of the State of California as a result of the transfer of title to the vestee named in Schedule A or as a result of changes in ownership or new construction occurring prior to Date of Policy.

**EXCEPTIONS
(Continued)**

1. Water rights, claims or title to water, whether or not disclosed by the public records.
2. Easement(s) in favor of the public over any existing roads lying within said Land.
3. Lack of right of access to and from a public street or highway.
4. Rights or claims of easements for canals, drains, laterals, irrigation pipelines and gates not recorded in the public record.
5. Title to, and easements in, any portion of the land lying within any highways, roads, streets, or other ways.
6. The herein described Land is located in an area frequently subject to Land Conservation Contracts executed pursuant to the Williamson Act (Cal. Govt. Code §§ 51200 et seq.). Land Conservation Contracts restrict the land use to agricultural, recreational, open-space and other compatible uses. If the herein described Land is subject to a Land Conservation Contract, please notify the Title Department.

The Company reserves the right to add additional items and/or make further requirements.

7. Canal right of way, dated October 4, 1915, Serial No. LA 026139 by Act of Congress March 3, 1891, as disclosed by the District Land Office of the Bureau of Land Management.

Affects: Lot 3 in Section 15 of Parcel 5.

8. Reservations contained in the Patent

From: The United States of America
Recording Date: February 16, 1916
Recording No: 20, [Book 7, Page 207](#), of Patents

Which among other things recites as follows:

Subject to any vested and accrued water rights for mining, agricultural, manufacturing, or other purposes and rights to ditches and reservoirs used in connection with such water rights, as may be recognized and acknowledged by the local customs, laws and decisions of the courts, and the reservation from the lands hereby granted, a right of way thereon for ditches or canals constructed by the authority of the United States.

Affects: Parcels 1 and 5.

**EXCEPTIONS
(Continued)**

9. Reservations contained in the Patent

From: The United States of America
Recording Date: August 20, 1919
Recording No: 24, [Book 9, Page 88](#), of Patents

Which among other things recites as follows:

Subject to any vested and accrued water rights for mining, agricultural, manufacturing, or other purposes and rights to ditches and reservoirs used in connection with such water rights, as may be recognized and acknowledged by the local customs, laws and decisions of the courts, and the reservation from the lands hereby granted, a right of way thereon for ditches or canals constructed by the authority of the United States.

Affects: A portion of Parcels 1, 2 and 3.

10. Easement(s) for the purpose(s) shown below and rights incidental thereto, as granted in a document:

Granted to: Imperial Water Company
Purpose: Irrigation purposes
Recording Date: March 26, 1913
Recording No: 33, [Book 69, Page 386](#), of Deeds
Affects: Parcel 3.

11. Matters contained in that certain document

Entitled: Agreement
Dated: July 26, 1923
Executed by: Imperial Irrigation District and Will Kimberly, et al.
Recording Date: December 1, 1924
Recording No: 90, [Book 68, Page 165](#), of Official Records

Reference is hereby made to said document for full particulars.

Among other things, said document provides for: Drainage ditches.

Affects: A right of way whose width shall not exceed one hundred and fifty (150) feet across, over Lots 3 and 4, in Section 15, as shown on the map attached to said document.

Affects: Parcel 5.

**EXCEPTIONS
(Continued)**

12. Reservations contained in the Patent

From: The United States of America
Recording Date: October 4, 1928
Recording No: 34, [Book 206, Page 223](#), of Official Records

Which among other things recites as follows:

Subject to any vested and accrued water rights for mining, agricultural, manufacturing, or other purposes and rights to ditches and reservoirs used in connection with such water rights, as may be recognized and acknowledged by the local customs, laws and decisions of the courts, and the reservation from the lands hereby granted, a right of way thereon for ditches or canals constructed by the authority of the United States.

Affects: Parcels 2 and 3.

13. Easement(s) for the purpose(s) shown below and rights incidental thereto, as granted in a document:

Granted to: Imperial Irrigation District
Purpose: Canal, telephone and power lines
Recording Date: November 4, 1952
Recording No: [Book 849, Page 666](#), of Official Records
Affects: A portion of said land as more particularly described in said document.

Affects: Parcels 2 and 3.

14. Easement(s) for the purpose(s) shown below and rights incidental thereto, as granted in a document:

Granted to: Imperial Irrigation District
Purpose: Canal, telephone and power lines
Recording Date: December 4, 1952
Recording No: [Book 849, Page 668](#), of Official Records
Affects: A portion of said land as more particularly described in said document.

Affects: Parcel 1.

15. Easement(s) for the purpose(s) shown below and rights incidental thereto as reserved in a document;

Reserved by: Imperial Irrigation District
Purpose: Irrigation, waste or drainage canals, or power or telephone lines and incidental purposes
Recording Date: December 5, 1952
Recording No: 23, [Book 851, Page 42](#), of Official Records
Affects: Parcels 2 and 3.

**EXCEPTIONS
(Continued)**

16. Matters contained in that certain document

Entitled: Agreement
Dated: April 12, 1977
Executed by: The Imperial Irrigation District and Earl A. Silzle, et ux.
Recording Date: April 19, 1977
Recording No: [Book 1400, Page 583](#), of Official Records

Reference is hereby made to said document for full particulars.

Among other things, said document provides for: Water delivery.

Affects: Parcels 1, 2 and 3.

17. Matters contained in that certain document

Entitled: Agreement
Dated: December 20, 1977
Executed by: Imperial Irrigation District and Earl A. Silzle, et ux.
Recording Date: January 4, 1978
Recording No: [Book 1410, Page 1432](#), of Official Records

Reference is hereby made to said document for full particulars.

Among other things, said document provides for: Operation and maintenance of the Verde Drain.

Affects: Parcels 1, 2 and 3.

18. Easement(s) for the purpose(s) shown below and rights incidental thereto as reserved in a document;

Reserved by: Imperial Irrigation District
Purpose: Irrigation, waste or drainage canals or power or telephone lines
Recording Date: April 5, 1979
Recording No: 1, [Book 1431, Page 1450](#), of Official Records
Affects: Parcel 4.

19. An unrecorded oil and gas lease for the term therein provided, with certain covenants, conditions and provisions, together with easements, if any, as set forth therein, disclosed by document

Entitled: Short Form of Lease and Agreement
Lessor: E. A. Silzle, et ux.
Lessee: Occidental Geothermal, Inc.
Recording Date: April 6, 1979
Recording No: [Book 1431, Page 1613](#), of Official Records

No assurance is made as to the present ownership of the leasehold created by said lease, nor as to other matters affecting the rights or interests of the lessor or lessee in said lease.

Affects: Parcels 1, 2 and 3.

**EXCEPTIONS
(Continued)**

20. An oil and gas lease for the term therein provided with certain covenants, conditions and provisions, together with easements, if any, as set forth therein.

Dated: July 14, 1981
Lessor: Bill Silzle, aka William Silzle, a married man dealing with his sole and separate property
Lessee: Emefco Petroleum, Inc.
Recording Date: August 28, 1981
Recording No: 52, [Book 1474, Page 49](#), of Official Records

No assurance is made as to the present ownership of the leasehold created by said lease, nor as to other matters affecting the rights or interests of the lessor or lessee in said lease.

Affects: Parcel 5.

21. An oil and gas lease for the term therein provided with certain covenants, conditions and provisions, together with easements, if any, as set forth therein.

Dated: July 14, 1981
Lessor: The Jet B Corporation, Inc., a California corporation
Lessee: Emefco Petroleum, Inc.
Recording Date: August 28, 1981
Recording No: 58, [Book 1474, Page 63](#), of Official Records

No assurance is made as to the present ownership of the leasehold created by said lease, nor as to other matters affecting the rights or interests of the lessor or lessee in said lease.

Affects: Parcels 1, 2 and 3.

22. An oil and gas lease for the term therein provided with certain covenants, conditions and provisions, together with easements, if any, as set forth therein.

Dated: June 14, 1981
Lessor: William Silzle, aka Bill Silzle and Barbara B. Bilzle, husband and wife as joint tenants
Lessee: Emefco Petroleum, Inc.
Recording Date: September 3, 1981
Recording No: 21, [Book 1474, Page 628](#), of Official Records

No assurance is made as to the present ownership of the leasehold created by said lease, nor as to other matters affecting the rights or interests of the lessor or lessee in said lease.

Affects: Parcel 4.

**EXCEPTIONS
(Continued)**

23. An option to purchase said Land with certain terms, covenants, conditions and provisions as set forth therein.

Optionor: Tammy Cheri Slater and Jimmie R. Doyle, Co-Trustees of the Exemption Trust under the Doyle Family 2010 Trust dated August 13, 2010 and Tammy Cheri Slater and Jimmie R. Doyle, Co-Trustees of the Survivor's Trust under the Doyle Family 2010 Trust, dated August 13, 2010

Optionee: Apex Energy Solutions, LLC, a California limited liability company

Disclosed by: Memorandum of Option for Purchase of Real Property

Recording Date: October 15, 2019

Recording No: [2019020829, of Official Records](#)

24. Any invalidity or defect in the title of the vestees in the event that the trust referred to herein is invalid or fails to grant sufficient powers to the trustee(s) or in the event there is a lack of compliance with the terms and provisions of the trust instrument.

If title is to be insured in the trustee(s) of a trust, (or if their act is to be insured), this Company will require a Trust Certification pursuant to California Probate Code Section 18100.5.

The Company reserves the right to add additional items or make further requirements after review of the requested documentation.

25. Please be advised that our search did not disclose any open Deeds of Trust of record. If you should have knowledge of any outstanding obligation, please contact the Title Department immediately for further review prior to closing.

26. Any rights of the parties in possession of a portion of, or all of, said Land, which rights are not disclosed by the public records.

The Company will require, for review, a full and complete copy of any unrecorded agreement, contract, license and/or lease, together with all supplements, assignments and amendments thereto, before issuing any policy of title insurance without excepting this item from coverage.

The Company reserves the right to except additional items and/or make additional requirements after reviewing said documents.

27. Any easements not disclosed by the public records as to matters affecting title to real property, whether or not said easements are visible and apparent.

28. Matters which may be disclosed by an inspection and/or by a correct ALTA/NSPS Land Title Survey of said Land that is satisfactory to the Company, and/or by inquiry of the parties in possession thereof.

PLEASE REFER TO THE "INFORMATIONAL NOTES" AND "REQUIREMENTS" SECTIONS WHICH FOLLOW FOR INFORMATION NECESSARY TO COMPLETE THIS TRANSACTION.

END OF EXCEPTIONS

REQUIREMENTS SECTION

1. The Company will require either (a) a complete copy of the trust agreement and any amendments thereto certified by the trustee(s) to be a true and complete copy with respect to the hereinafter named trust, or (b) a Certification, pursuant to California Probate Code Section 18100.5, executed by all of the current trustee(s) of the hereinafter named trust, a form of which is attached.

Name of Trust: The Exemption Trust under the Doyle Family 2010 Trust, dated August 13, 2010

2. The Company will require either (a) a complete copy of the trust agreement and any amendments thereto certified by the trustee(s) to be a true and complete copy with respect to the hereinafter named trust, or (b) a Certification, pursuant to California Probate Code Section 18100.5, executed by all of the current trustee(s) of the hereinafter named trust, a form of which is attached.

Name of Trust: The Survivor's Trust under the Doyle Family 2010 Trust, dated August 13, 2010

3. Prior to the close of escrow, the Company requires a Statement of Information to be completed by the following party(s),

Party(s): All Parties

The Company reserves the right to add additional items or make further requirements after review of the requested Statement of Information.

4. Unrecorded matters which may be disclosed by an Owner's Affidavit or Declaration. A form of the Owner's Affidavit/Declaration is attached to this Preliminary Report/Commitment. This Affidavit/Declaration is to be completed by the record owner of the land and submitted for review prior to the closing of this transaction. Your prompt attention to this requirement will help avoid delays in the closing of this transaction. Thank you.

The Company reserves the right to add additional items or make further requirements after review of the requested Affidavit/Declaration.

END OF REQUIREMENTS

INFORMATIONAL NOTES SECTION

1. Note: The policy of title insurance will include an arbitration provision. The Company or the insured may demand arbitration. Arbitrable matters may include, but are not limited to, any controversy or claim between the Company and the insured arising out of or relating to this policy, any service of the Company in connection with its issuance or the breach of a policy provision or other obligation. Please ask your escrow or title officer for a sample copy of the policy to be issued if you wish to review the arbitration provisions and any other provisions pertaining to your Title Insurance coverage.
2. Notice: Please be aware that due to the conflict between federal and state laws concerning the cultivation, distribution, manufacture or sale of marijuana, the Company is not able to close or insure any transaction involving Land that is associated with these activities.
3. Pursuant to Government Code Section 27388.1, as amended and effective as of 1-1-2018, a Documentary Transfer Tax (DTT) Affidavit may be required to be completed and submitted with each document when DTT is being paid or when an exemption is being claimed from paying the tax. If a governmental agency is a party to the document, the form will not be required. DTT Affidavits may be available at a Tax Assessor-County Clerk-Recorder.
4. Due to the special requirements of SB 50 (California Public Resources Code Section 8560 et seq.), any transaction that includes the conveyance of title by an agency of the United States must be approved in advance by the Company's State Counsel, Regional Counsel, or one of their designees.
5. Note: The only conveyance(s) affecting said Land, which recorded within 24 months of the date of this report, are as follows:

Grantor:	Jimmy C. Doyle, decedent
Grantee:	Jimmie R. Doyle and Tammy Cheri Slater, Successor Trustees of the Doyle Family 2010 Trust
Recording Date:	August 30, 2019
<u>Recording No:</u>	<u>2019016567, of Official Records</u>

END OF INFORMATIONAL NOTES

Mitch LaRiva/717

Wire Fraud Alert

This Notice is not intended to provide legal or professional advice. If you have any questions, please consult with a lawyer.

All parties to a real estate transaction are targets for wire fraud and many have lost hundreds of thousands of dollars because they simply relied on the wire instructions received via email, without further verification. **If funds are to be wired in conjunction with this real estate transaction, we strongly recommend verbal verification of wire instructions through a known, trusted phone number prior to sending funds.**

In addition, the following non-exclusive self-protection strategies are recommended to minimize exposure to possible wire fraud.

- **NEVER RELY** on emails purporting to change wire instructions. Parties to a transaction rarely change wire instructions in the course of a transaction.
- **ALWAYS VERIFY** wire instructions, specifically the ABA routing number and account number, by calling the party who sent the instructions to you. DO NOT use the phone number provided in the email containing the instructions, use phone numbers you have called before or can otherwise verify. **Obtain the phone number of relevant parties to the transaction as soon as an escrow account is opened.** DO NOT send an email to verify as the email address may be incorrect or the email may be intercepted by the fraudster.
- **USE COMPLEX EMAIL PASSWORDS** that employ a combination of mixed case, numbers, and symbols. Make your passwords greater than eight (8) characters. Also, change your password often and do NOT reuse the same password for other online accounts.
- **USE MULTI-FACTOR AUTHENTICATION** for email accounts. Your email provider or IT staff may have specific instructions on how to implement this feature.

For more information on wire-fraud scams or to report an incident, please refer to the following links:

Federal Bureau of Investigation:
<http://www.fbi.gov>

Internet Crime Complaint Center:
<http://www.ic3.gov>

Fidelity National Title Company

4210 Riverwalk Parkway, Suite 200
 Riverside, CA 92505
 Phone: (951) 710-5912 • Fax:

Notice of Available Discounts

Pursuant to Section 2355.3 in Title 10 of the California Code of Regulations Fidelity National Financial, Inc. and its subsidiaries ("FNF") must deliver a notice of each discount available under our current rate filing along with the delivery of escrow instructions, a preliminary report or commitment. Please be aware that the provision of this notice does not constitute a waiver of the consumer's right to be charged the filed rate. As such, your transaction may not qualify for the below discounts.

You are encouraged to discuss the applicability of one or more of the below discounts with a Company representative. These discounts are generally described below; consult the rate manual for a full description of the terms, conditions and requirements for such discount. These discounts only apply to transactions involving services rendered by the FNF Family of Companies. This notice only applies to transactions involving property improved with a one-to-four family residential dwelling.

Not all discounts are offered by every FNF Company. The discount will only be applicable to the FNF Company as indicated by the named discount.

FNF Underwritten Title Company

CTC – Chicago Title company
 CLTC – Commonwealth Land Title Company
 FNTC – Fidelity National Title Company of California
 FNTCCA - Fidelity National Title Company of California
 TICOR – Ticor Title Company of California
 LTC – Lawyer's Title Company
 SLTC – ServiceLink Title Company

Underwritten by FNF Underwriters

CTIC – Chicago Title Insurance Company
 CLTIC - Commonwealth Land Title Insurance Company
 FNTIC – Fidelity National Title Insurance Company
 FNTIC - Fidelity National Title Insurance Company
 CTIC – Chicago Title Insurance Company
 CLTIC – Commonwealth Land Title Insurance Company
 CTIC – Chicago Title Insurance Company

Available Discounts

DISASTER LOANS (CTIC, CLTIC, FNTIC)

The charge for a Lender's Policy (Standard or Extended coverage) covering the financing or refinancing by an owner of record, within twenty-four (24) months of the date of a declaration of a disaster area by the government of the United States or the State of California on any land located in said area, which was partially or totally destroyed in the disaster, will be fifty percent (50%) of the appropriate title insurance rate.

CHURCHES OR CHARITABLE NON-PROFIT ORGANIZATIONS (CTIC, FNTIC)

On properties used as a church or for charitable purposes within the scope of the normal activities of such entities, provided said charge is normally the church's obligation the charge for an owner's policy shall be fifty percent (50%) to seventy percent (70%) of the appropriate title insurance rate, depending on the type of coverage selected. The charge for a lender's policy shall be forty (40%) to fifty percent (50%) of the appropriate title insurance rate, depending on the type of coverage selected.

FIDELITY NATIONAL FINANCIAL, INC. PRIVACY NOTICE

Effective April 9, 2020

Fidelity National Financial, Inc. and its majority-owned subsidiary companies (collectively, “FNF,” “our,” or “we”) respect and are committed to protecting your privacy. This Privacy Notice explains how we collect, use, and protect personal information, when and to whom we disclose such information, and the choices you have about the use and disclosure of that information.

A limited number of FNF subsidiaries have their own privacy notices. If a subsidiary has its own privacy notice, the privacy notice will be available on the subsidiary’s website and this Privacy Notice does not apply.

Collection of Personal Information

FNF may collect the following categories of Personal Information:

- contact information (e.g., name, address, phone number, email address);
- demographic information (e.g., date of birth, gender, marital status);
- identity information (e.g. Social Security Number, driver’s license, passport, or other government ID number);
- financial account information (e.g. loan or bank account information); and
- other personal information necessary to provide products or services to you.

We may collect Personal Information about you from:

- information we receive from you or your agent;
- information about your transactions with FNF, our affiliates, or others; and
- information we receive from consumer reporting agencies and/or governmental entities, either directly from these entities or through others.

Collection of Browsing Information

FNF automatically collects the following types of Browsing Information when you access an FNF website, online service, or application (each an “FNF Website”) from your Internet browser, computer, and/or device:

- Internet Protocol (IP) address and operating system;
- browser version, language, and type;
- domain name system requests; and
- browsing history on the FNF Website, such as date and time of your visit to the FNF Website and visits to the pages within the FNF Website.

Like most websites, our servers automatically log each visitor to the FNF Website and may collect the Browsing Information described above. We use Browsing Information for system administration, troubleshooting, fraud investigation, and to improve our websites. Browsing Information generally does not reveal anything personal about you, though if you have created a user account for an FNF Website and are logged into that account, the FNF Website may be able to link certain browsing activity to your user account.

Other Online Specifics

Cookies. When you visit an FNF Website, a “cookie” may be sent to your computer. A cookie is a small piece of data that is sent to your Internet browser from a web server and stored on your computer’s hard drive. Information gathered using cookies helps us improve your user experience. For example, a cookie can help the website load properly or can customize the display page based on your browser type and user preferences. You can choose whether or not to accept cookies by changing your Internet browser settings. Be aware that doing so may impair or limit some functionality of the FNF Website.

Web Beacons. We use web beacons to determine when and how many times a page has been viewed. This information is used to improve our websites.

Do Not Track. Currently our FNF Websites do not respond to “Do Not Track” features enabled through your browser.

Links to Other Sites. FNF Websites may contain links to unaffiliated third-party websites. FNF is not responsible for the privacy practices or content of those websites. We recommend that you read the privacy policy of every website you visit.

Use of Personal Information

FNF uses Personal Information for three main purposes:

- To provide products and services to you or in connection with a transaction involving you.
- To improve our products and services.
- To communicate with you about our, our affiliates’, and others’ products and services, jointly or independently.

When Information Is Disclosed

We may disclose your Personal Information and Browsing Information in the following circumstances:

- to enable us to detect or prevent criminal activity, fraud, material misrepresentation, or nondisclosure;
- to nonaffiliated service providers who provide or perform services or functions on our behalf and who agree to use the information only to provide such services or functions;

- to nonaffiliated third party service providers with whom we perform joint marketing, pursuant to an agreement with them to jointly market financial products or services to you;
- to law enforcement or authorities in connection with an investigation, or in response to a subpoena or court order; or
- in the good-faith belief that such disclosure is necessary to comply with legal process or applicable laws, or to protect the rights, property, or safety of FNF, its customers, or the public.

The law does not require your prior authorization and does not allow you to restrict the disclosures described above. Additionally, we may disclose your information to third parties for whom you have given us authorization or consent to make such disclosure. We do not otherwise share your Personal Information or Browsing Information with nonaffiliated third parties, except as required or permitted by law. We may share your Personal Information with affiliates (other companies owned by FNF) to directly market to you. Please see "Choices with Your Information" to learn how to restrict that sharing.

We reserve the right to transfer your Personal Information, Browsing Information, and any other information, in connection with the sale or other disposition of all or part of the FNF business and/or assets, or in the event of bankruptcy, reorganization, insolvency, receivership, or an assignment for the benefit of creditors. By submitting Personal Information and/or Browsing Information to FNF, you expressly agree and consent to the use and/or transfer of the foregoing information in connection with any of the above described proceedings.

Security of Your Information

We maintain physical, electronic, and procedural safeguards to protect your Personal Information.

Choices With Your Information

If you do not want FNF to share your information among our affiliates to directly market to you, you may send an "opt out" request by email, phone, or physical mail as directed at the end of this Privacy Notice. We do not share your Personal Information with nonaffiliates for their use to direct market to you without your consent.

Whether you submit Personal Information or Browsing Information to FNF is entirely up to you. If you decide not to submit Personal Information or Browsing Information, FNF may not be able to provide certain services or products to you.

For California Residents: We will not share your Personal Information or Browsing Information with nonaffiliated third parties, except as permitted by California law. For additional information about your California privacy rights, please visit the "California Privacy" link on our website (<https://fnf.com/pages/californiaprivacy.aspx>) or call (888) 413-1748.

For Nevada Residents: You may be placed on our internal Do Not Call List by calling (888) 934-3354 or by contacting us via the information set forth at the end of this Privacy Notice. Nevada law requires that we also provide you with the following contact information: Bureau of Consumer Protection, Office of the Nevada Attorney General, 555 E. Washington St., Suite 3900, Las Vegas, NV 89101; Phone number: (702) 486-3132; email: BCPINFO@ag.state.nv.us.

For Oregon Residents: We will not share your Personal Information or Browsing Information with nonaffiliated third parties for marketing purposes, except after you have been informed by us of such sharing and had an opportunity to indicate that you do not want a disclosure made for marketing purposes.

For Vermont Residents: We will not disclose information about your creditworthiness to our affiliates and will not disclose your personal information, financial information, credit report, or health information to nonaffiliated third parties to market to you, other than as permitted by Vermont law, unless you authorize us to make those disclosures.

Information From Children

The FNF Websites are not intended or designed to attract persons under the age of eighteen (18). We do not collect Personal Information from any person that we know to be under the age of thirteen (13) without permission from a parent or guardian.

International Users

FNF's headquarters is located within the United States. If you reside outside the United States and choose to provide Personal Information or Browsing Information to us, please note that we may transfer that information outside of your country of residence. By providing FNF with your Personal Information and/or Browsing Information, you consent to our collection, transfer, and use of such information in accordance with this Privacy Notice.

FNF Website Services for Mortgage Loans

Certain FNF companies provide services to mortgage loan servicers, including hosting websites that collect customer information on behalf of mortgage loan servicers (the "Service Websites"). The Service Websites may contain links to both this Privacy Notice and the mortgage loan servicer or lender's privacy notice. The sections of this Privacy Notice titled When Information is Disclosed, Choices with Your Information, and Accessing and Correcting Information do not apply to the Service Websites. The mortgage loan servicer or lender's privacy notice governs use, disclosure, and access to your Personal Information. FNF does not share Personal Information collected through the Service Websites, except as required or authorized by contract with the mortgage loan servicer or lender, or as required by law or in the good-faith belief that such disclosure is necessary: to comply with a legal process or applicable law, to enforce this Privacy Notice, or to protect the rights, property, or safety of FNF or the public.

Your Consent To This Privacy Notice; Notice Changes; Use of Comments or Feedback

By submitting Personal Information and/or Browsing Information to FNF, you consent to the collection and use of the information in accordance with this Privacy Notice. We may change this Privacy Notice at any time. The Privacy Notice's effective date will show the last date changes were made. If you provide information to us following any change of the Privacy Notice, that signifies your assent to and acceptance of the changes to the Privacy Notice. We may use comments or feedback that you submit to us in any manner without notice or compensation to you.

Accessing and Correcting Information; Contact Us

If you have questions, would like to correct your Personal Information, or want to opt-out of information sharing for affiliate marketing, send your requests to privacy@fnf.com, by phone to (888) 934-3354, or by mail to:

Fidelity National Financial, Inc.
601 Riverside Avenue
Jacksonville, Florida 32204
Attn: Chief Privacy Officer

ATTACHMENT ONE (Revised 05-06-16)

CALIFORNIA LAND TITLE ASSOCIATION STANDARD COVERAGE POLICY – 1990

EXCLUSIONS FROM COVERAGE

The following matters are expressly excluded from the coverage of this policy and the Company will not pay loss or damage, costs, attorneys' fees or expenses which arise by reason of:

1. (a) Any law, ordinance or governmental regulation (including but not limited to building or zoning laws, ordinances, or regulations) restricting, regulating, prohibiting or relating (i) the occupancy, use, or enjoyment of the land; (ii) the character, dimensions or location of any improvement now or hereafter erected on the land; (iii) a separation in ownership or a change in the dimensions or area of the land or any parcel of which the land is or was a part; or (iv) environmental protection, or the effect of any violation of these laws, ordinances or governmental regulations, except to the extent that a notice of the enforcement thereof or a notice of a defect, lien, or encumbrance resulting from a violation or alleged violation affecting the land has been recorded in the public records at Date of Policy.
- (b) Any governmental police power not excluded by (a) above, except to the extent that a notice of the exercise thereof or notice of a defect, lien or encumbrance resulting from a violation or alleged violation affecting the land has been recorded in the public records at Date of Policy.
2. Rights of eminent domain unless notice of the exercise thereof has been recorded in the public records at Date of Policy, but not excluding from coverage any taking which has occurred prior to Date of Policy which would be binding on the rights of a purchaser for value without knowledge.
3. Defects, liens, encumbrances, adverse claims or other matters:
 - (a) whether or not recorded in the public records at Date of Policy, but created, suffered, assumed or agreed to by the insured claimant;
 - (b) not known to the Company, not recorded in the public records at Date of Policy, but known to the insured claimant and not disclosed in writing to the Company by the insured claimant prior to the date the insured claimant became an insured under this policy;
 - (c) resulting in no loss or damage to the insured claimant;
 - (d) attaching or created subsequent to Date of Policy; or
 - (e) resulting in loss or damage which would not have been sustained if the insured claimant had paid value for the insured mortgage or for the estate or interest insured by this policy.
4. Unenforceability of the lien of the insured mortgage because of the inability or failure of the insured at Date of Policy, or the inability or failure of any subsequent owner of the indebtedness, to comply with the applicable doing business laws of the state in which the land is situated.
5. Invalidity or unenforceability of the lien of the insured mortgage, or claim thereof, which arises out of the transaction evidenced by the insured mortgage and is based upon usury or any consumer credit protection or truth in lending law.
6. Any claim, which arises out of the transaction vesting in the insured the estate of interest insured by this policy or the transaction creating the interest of the insured lender, by reason of the operation of federal bankruptcy, state insolvency or similar creditors' rights laws.

EXCEPTIONS FROM COVERAGE - SCHEDULE B, PART I

This policy does not insure against loss or damage (and the Company will not pay costs, attorneys' fees or expenses) which arise by reason of:

1. Taxes or assessments which are not shown as existing liens by the records of any taxing authority that levies taxes or assessments on real property or by the public records.
Proceedings by a public agency which may result in taxes or assessments, or notices of such proceedings, whether or not shown by the records of such agency or by the public records.
2. Any facts, rights, interests, or claims which are not shown by the public records but which could be ascertained by an inspection of the land or which may be asserted by persons in possession thereof.
3. Easements, liens or encumbrances, or claims thereof, not shown by the public records.
4. Discrepancies, conflicts in boundary lines, shortage in area, encroachments, or any other facts which a correct survey would disclose, and which are not shown by the public records.
5. (a) Unpatented mining claims; (b) reservations or exceptions in patents or in Acts authorizing the issuance thereof; (c) water rights, claims or title to water, whether or not the matters excepted under (a), (b) or (c) are shown by the public records.
6. Any lien or right to a lien for services, labor or material not shown by the public records.

CLTA HOMEOWNER'S POLICY OF TITLE INSURANCE (12-02-13) ALTA HOMEOWNER'S POLICY OF TITLE INSURANCE

EXCLUSIONS

In addition to the Exceptions in Schedule B, You are not insured against loss, costs, attorneys' fees, and expenses resulting from:

1. Governmental police power, and the existence or violation of those portions of any law or government regulation concerning:
 - a. building;
 - b. zoning;
 - c. land use;
 - d. improvements on the Land;
 - e. land division; and
 - f. environmental protection.This Exclusion does not limit the coverage described in Covered Risk 8.a., 14, 15, 16, 18, 19, 20, 23 or 27.
2. The failure of Your existing structures, or any part of them, to be constructed in accordance with applicable building codes. This Exclusion does not limit the coverage described in Covered Risk 14 or 15.
3. The right to take the Land by condemning it. This Exclusion does not limit the coverage described in Covered Risk 17.
4. Risks:
 - a. that are created, allowed, or agreed to by You, whether or not they are recorded in the Public Records;
 - b. that are Known to You at the Policy Date, but not to Us, unless they are recorded in the Public Records at the Policy Date;

- c. that result in no loss to You; or
 - d. that first occur after the Policy Date - this does not limit the coverage described in Covered Risk 7, 8.e., 25, 26, 27 or 28.
5. Failure to pay value for Your Title.
 6. Lack of a right:
 - a. to any land outside the area specifically described and referred to in paragraph 3 of Schedule A; and
 - b. in streets, alleys, or waterways that touch the Land.
 This Exclusion does not limit the coverage described in Covered Risk 11 or 21.
 7. The transfer of the Title to You is invalid as a preferential transfer or as a fraudulent transfer or conveyance under federal bankruptcy, state insolvency, or similar creditors' rights laws.
 8. Contamination, explosion, fire, flooding, vibration, fracturing, earthquake, or subsidence.
 9. Negligence by a person or an Entity exercising a right to extract or develop minerals, water, or any other substances.

LIMITATIONS ON COVERED RISKS

Your insurance for the following Covered Risks is limited on the Owner's Coverage Statement as follows:

- For Covered Risk 16, 18, 19, and 21 Your Deductible Amount and Our Maximum Dollar Limit of Liability shown in Schedule A.

The deductible amounts and maximum dollar limits shown on Schedule A are as follows:

	Your Deductible Amount	Our Maximum Dollar Limit of Liability
Covered Risk 16:	1.00% of Policy Amount Shown in Schedule A or \$2,500.00 (whichever is less)	\$ 10,000.00
Covered Risk 18:	1.00% of Policy Amount Shown in Schedule A or \$5,000.00 (whichever is less)	\$ 25,000.00
Covered Risk 19:	1.00% of Policy Amount Shown in Schedule A or \$5,000.00 (whichever is less)	\$ 25,000.00
Covered Risk 21:	1.00% of Policy Amount Shown in Schedule A or \$2,500.00 (whichever is less)	\$ 5,000.00

2006 ALTA LOAN POLICY (06-17-06)

EXCLUSIONS FROM COVERAGE

The following matters are expressly excluded from the coverage of this policy, and the Company will not pay loss or damage, costs, attorneys' fees, or expenses that arise by reason of:

1. (a) Any law, ordinance, permit, or governmental regulation (including those relating to building and zoning) restricting, regulating, prohibiting, or relating to
 - (i) the occupancy, use, or enjoyment of the Land;
 - (ii) the character, dimensions, or location of any improvement erected on the Land;
 - (iii) the subdivision of land; or
 - (iv) environmental protection;
 or the effect of any violation of these laws, ordinances, or governmental regulations. This Exclusion 1(a) does not modify or limit the coverage provided under Covered Risk 5.
- (b) Any governmental police power. This Exclusion 1(b) does not modify or limit the coverage provided under Covered Risk 6.
2. Rights of eminent domain. This Exclusion does not modify or limit the coverage provided under Covered Risk 7 or 8.
3. Defects, liens, encumbrances, adverse claims, or other matters
 - (a) created, suffered, assumed, or agreed to by the Insured Claimant;
 - (b) not Known to the Company, not recorded in the Public Records at Date of Policy, but Known to the Insured Claimant and not disclosed in writing to the Company by the Insured Claimant prior to the date the Insured Claimant became an Insured under this policy;
 - (c) resulting in no loss or damage to the Insured Claimant;
 - (d) attaching or created subsequent to Date of Policy (however, this does not modify or limit the coverage provided under Covered Risk 11, 13 or 14); or
 - (e) resulting in loss or damage that would not have been sustained if the Insured Claimant had paid value for the Insured Mortgage.
4. Unenforceability of the lien of the Insured Mortgage because of the inability or failure of an Insured to comply with applicable doing-business laws of the state where the Land is situated.
5. Invalidity or unenforceability in whole or in part of the lien of the Insured Mortgage that arises out of the transaction evidenced by the Insured Mortgage and is based upon usury or any consumer credit protection or truth-in-lending law.
6. Any claim, by reason of the operation of federal bankruptcy, state insolvency, or similar creditors' rights laws, that the transaction creating the lien of the Insured Mortgage, is
 - (a) a fraudulent conveyance or fraudulent transfer, or
 - (b) a preferential transfer for any reason not stated in Covered Risk 13(b) of this policy.
7. Any lien on the Title for real estate taxes or assessments imposed by governmental authority and created or attaching between Date of Policy and the date of recording of the Insured Mortgage in the Public Records. This Exclusion does not modify or limit the coverage provided under Covered Risk 11(b).

The above policy form may be issued to afford either Standard Coverage or Extended Coverage. In addition to the above Exclusions from Coverage, the Exceptions from Coverage in a Standard Coverage policy will also include the following Exceptions from Coverage:

EXCEPTIONS FROM COVERAGE

{Except as provided in Schedule B - Part II, {t{or T}his policy does not insure against loss or damage, and the Company will not pay costs, attorneys' fees or expenses, that arise by reason of:

{PART I

{The above policy form may be issued to afford either Standard Coverage or Extended Coverage. In addition to the above Exclusions from Coverage, the Exceptions from Coverage in a Standard Coverage policy will also include the following Exceptions from Coverage:

1. (a) Taxes or assessments that are not shown as existing liens by the records of any taxing authority that levies taxes or assessments on real property or by the Public Records; (b) proceedings by a public agency that may result in taxes or assessments, or notices of such proceedings, whether or not shown by the records of such agency or by the Public Records.
2. Any facts, rights, interests, or claims that are not shown by the Public Records but that could be ascertained by an inspection of the Land or that may be asserted by persons in possession of the Land.
3. Easements, liens or encumbrances, or claims thereof, not shown by the Public Records.
4. Any encroachment, encumbrance, violation, variation, or adverse circumstance affecting the Title that would be disclosed by an accurate and complete land survey of the Land and not shown by the Public Records.
5. (a) Unpatented mining claims; (b) reservations or exceptions in patents or in Acts authorizing the issuance thereof; (c) water rights, claims or title to water, whether or not the matters excepted under (a), (b), or (c) are shown by the Public Records.
6. Any lien or right to a lien for services, labor or material not shown by the Public Records.}

PART II

In addition to the matters set forth in Part I of this Schedule, the Title is subject to the following matters, and the Company insures against loss or damage sustained in the event that they are not subordinate to the lien of the Insured Mortgage:}

2006 ALTA OWNER'S POLICY (06-17-06)

EXCLUSIONS FROM COVERAGE

The following matters are expressly excluded from the coverage of this policy, and the Company will not pay loss or damage, costs, attorneys' fees, or expenses that arise by reason of:

1. (a) Any law, ordinance, permit, or governmental regulation (including those relating to building and zoning) restricting, regulating, prohibiting, or relating to
 - (i) the occupancy, use, or enjoyment of the Land;
 - (ii) the character, dimensions, or location of any improvement erected on the Land;
 - (iii) the subdivision of land; or
 - (iv) environmental protection;or the effect of any violation of these laws, ordinances, or governmental regulations. This Exclusion 1(a) does not modify or limit the coverage provided under Covered Risk 5.
 - (b) Any governmental police power. This Exclusion 1(b) does not modify or limit the coverage provided under Covered Risk 6.
2. Rights of eminent domain. This Exclusion does not modify or limit the coverage provided under Covered Risk 7 or 8.
3. Defects, liens, encumbrances, adverse claims, or other matters
 - (a) created, suffered, assumed, or agreed to by the Insured Claimant;
 - (b) not known to the Company, not recorded in the Public Records at Date of Policy, but known to the Insured Claimant and not disclosed in writing to the Company by the Insured Claimant prior to the date the Insured Claimant became an Insured under this policy;
 - (c) resulting in no loss or damage to the Insured Claimant;
 - (d) attaching or created subsequent to Date of Policy (however, this does not modify or limit the coverage provided under Covered Risk 9 and 10); or
 - (e) resulting in loss or damage that would not have been sustained if the Insured Claimant had paid value for the Title.
4. Any claim, by reason of the operation of federal bankruptcy, state insolvency, or similar creditors' rights laws, that the transaction vesting the Title as shown in Schedule A, is
 - (a) a fraudulent conveyance or fraudulent transfer; or
 - (b) a preferential transfer for any reason not stated in Covered Risk 9 of this policy.
5. Any lien on the Title for real estate taxes or assessments imposed by governmental authority and created or attaching between Date of Policy and the date of recording of the deed or other instrument of transfer in the Public Records that vests Title as shown in Schedule A.

The above policy form may be issued to afford either Standard Coverage or Extended Coverage. In addition to the above Exclusions from Coverage, the Exceptions from Coverage in a Standard Coverage policy will also include the following Exceptions from Coverage:

EXCEPTIONS FROM COVERAGE

This policy does not insure against loss or damage, and the Company will not pay costs, attorneys' fees or expenses, that arise by reason of:

{The above policy form may be issued to afford either Standard Coverage or Extended Coverage. In addition to the above Exclusions from Coverage, the Exceptions from Coverage in a Standard Coverage policy will also include the following Exceptions from Coverage:

1. (a) Taxes or assessments that are not shown as existing liens by the records of any taxing authority that levies taxes or assessments on real property or by the Public Records; (b) proceedings by a public agency that may result in taxes or assessments, or notices of such proceedings, whether or not shown by the records of such agency or by the Public Records.
2. Any facts, rights, interests, or claims that are not shown in the Public Records but that could be ascertained by an inspection of the Land or that may be asserted by persons in possession of the Land.
3. Easements, liens or encumbrances, or claims thereof, not shown by the Public Records.
4. Any encroachment, encumbrance, violation, variation, or adverse circumstance affecting the Title that would be disclosed by an accurate and complete land survey of the Land and that are not shown by the Public Records.
5. (a) Unpatented mining claims; (b) reservations or exceptions in patents or in Acts authorizing the issuance thereof; (c) water rights, claims or title to water, whether or not the matters excepted under (a), (b), or (c) are shown by the Public Records.
6. Any lien or right to a lien for services, labor or material not shown by the Public Records. }
7. {Variable exceptions such as taxes, easements, CC&R's, etc. shown here.}

ALTA EXPANDED COVERAGE RESIDENTIAL LOAN POLICY – ASSESSMENTS PRIORITY (04-02-15)

EXCLUSIONS FROM COVERAGE

The following matters are expressly excluded from the coverage of this policy and the Company will not pay loss or damage, costs, attorneys' fees or expenses which arise by reason of:

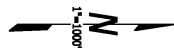
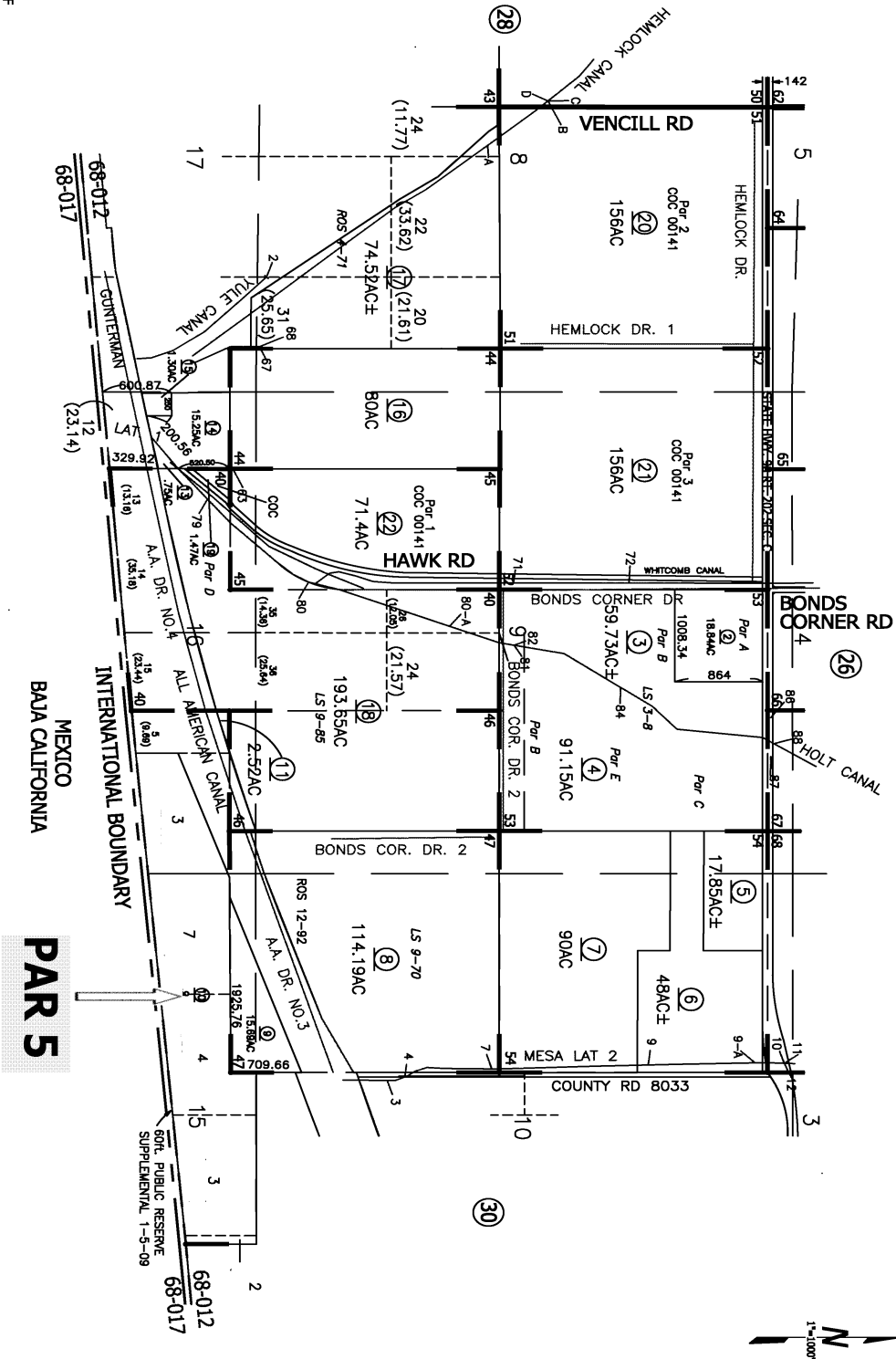
1. (a) Any law, ordinance, permit, or governmental regulation (including those relating to building and zoning) restricting, regulating, prohibiting, or relating to
 - (i) the occupancy, use, or enjoyment of the Land;
 - (ii) the character, dimensions, or location of any improvement erected on the Land;
 - (iii) the subdivision of land; or
 - (iv) environmental protection;or the effect of any violation of these laws, ordinances, or governmental regulations. This Exclusion 1(a) does not modify or limit the coverage provided under Covered Risk 5, 6, 13(c), 13(d), 14 or 16.
- (b) Any governmental police power. This Exclusion 1(b) does not modify or limit the coverage provided under Covered Risk 5, 6, 13(c), 13(d), 14 or 16.
2. Rights of eminent domain. This Exclusion does not modify or limit the coverage provided under Covered Risk 7 or 8.
3. Defects, liens, encumbrances, adverse claims, or other matters
 - (a) created, suffered, assumed, or agreed to by the Insured Claimant;
 - (b) not Known to the Company, not recorded in the Public Records at Date of Policy, but Known to the Insured Claimant and not disclosed in writing to the Company by the Insured Claimant prior to the date the Insured Claimant became an Insured under this policy;
 - (c) resulting in no loss or damage to the Insured Claimant;
 - (d) attaching or created subsequent to Date of Policy (however, this does not modify or limit the coverage provided under Covered Risk 11, 16, 17, 18, 19, 20, 21, 22, 23, 24, 27 or 28); or
 - (e) resulting in loss or damage that would not have been sustained if the Insured Claimant had paid value for the Insured Mortgage.
4. Unenforceability of the lien of the Insured Mortgage because of the inability or failure of an Insured to comply with applicable doing-business laws of the state where the Land is situated.
5. Invalidity or unenforceability in whole or in part of the lien of the Insured Mortgage that arises out of the transaction evidenced by the Insured Mortgage and is based upon usury, or any consumer credit protection or truth-in-lending law. This Exclusion does not modify or limit the coverage provided in Covered Risk 26.
6. Any claim of invalidity, unenforceability or lack of priority of the lien of the Insured Mortgage as to Advances or modifications made after the Insured has Knowledge that the vestee shown in Schedule A is no longer the owner of the estate or interest covered by this policy. This Exclusion does not modify or limit the coverage provided in Covered Risk 11.
7. Any lien on the Title for real estate taxes or assessments imposed by governmental authority and created or attaching subsequent to Date of Policy. This Exclusion does not modify or limit the coverage provided in Covered Risk 11(b) or 25.
8. The failure of the residential structure, or any portion of it, to have been constructed before, on or after Date of Policy in accordance with applicable building codes. This Exclusion does not modify or limit the coverage provided in Covered Risk 5 or 6.
9. Any claim, by reason of the operation of federal bankruptcy, state insolvency, or similar creditors' rights laws, that the transaction creating the lien of the Insured Mortgage, is
 - (a) a fraudulent conveyance or fraudulent transfer, or
 - (b) a preferential transfer for any reason not stated in Covered Risk 27(b) of this policy.
10. Contamination, explosion, fire, flooding, vibration, fracturing, earthquake, or subsidence.
11. Negligence by a person or an Entity exercising a right to extract or develop minerals, water, or any other substances.

This map/plat is being furnished as an aid in locating the herein described Land in relation to adjoining streets, natural boundaries and other land, and is not a survey of the land depicted. Except to the extent a policy of title insurance is expressly modified by endorsement, if any, the Company does not insure dimensions, distances, location of easements, acreage or other matters shown thereon.

TRACT 40,44,45,46,47,51,52,53 & 54
 POR. SEC. 8,9,10,15,16 & 17 T17S R16E

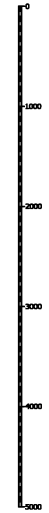
Tax Area Code
 68-012
 68-017

59-29



- 9-9-09 MF
- 8-17-09 MF
- 7-1-04 AR
- 04-26-93 DP
- 01-02-92 RM
- 03-25-80 LJ
- 01-18-78 LS
- From 57-51
- 3-27-12 MF
- 1-14-10 MF

DISCLAIMER:
 THIS IS NOT AN OFFICIAL MAP
 THIS MAP WAS CREATED FOR THE IMPERIAL COUNTY
 ASSESSOR, FOR THE SOLE PURPOSE OF AIDING IN
 THE PERFORMANCE OF THE DUTIES OF THE ASSESSOR.
 ANY ERRORS OR OMISSIONS IN THIS MAP ARE NOT
 THE RESPONSIBILITY OF THE COUNTY OF IMPERIAL
 OR THE ASSESSOR. (REV. & TAX CODE SEC.327)



PAR 5

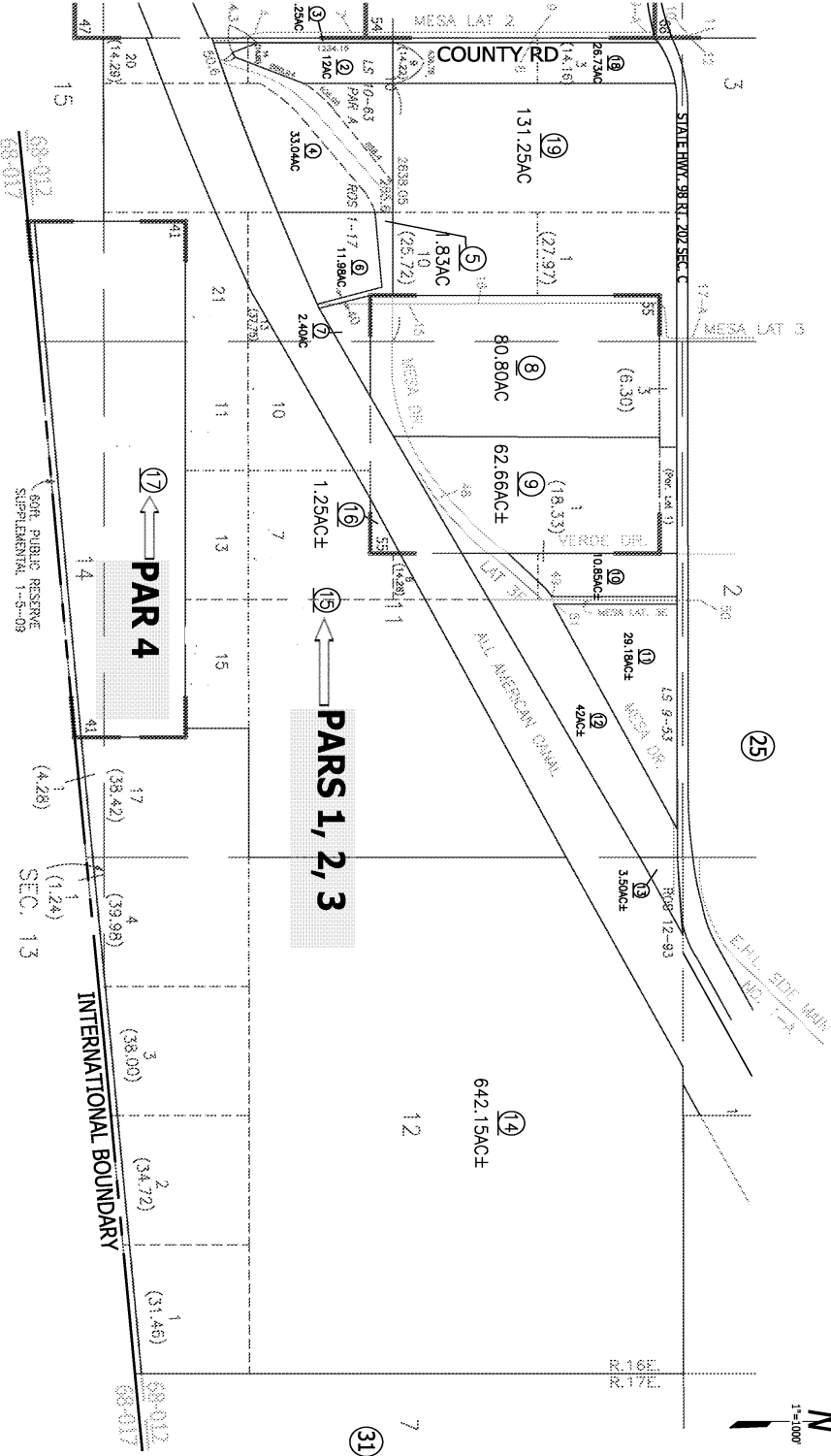
Assessor's Map Bk.59-Pg.29
 County of Imperial, Calif.

This map/plat is being furnished as an aid in locating the herein described Land in relation to adjoining streets, natural boundaries and other land, and is not a survey of the land depicted. Except to the extent a policy of title insurance is expressly modified by endorsement, if any, the Company does not insure dimensions, distances, location of easements, acreage or other matters shown thereon.

TRACT 41 & 55
 SEC. 11 & 12 POR, SEC. 1, 10, 13, 14 & 15
 T.17S, R.16E, S.B.B. & M.

Tax Area Code
 68-012
 68-017

59-30



10-25-10 MF
 1-14-10 MF
 9-05-07 MF
 3-25-80 JJ
 1-18-78 JJ
 From 57-52

DISCLAIMER:
 THIS IS NOT AN OFFICIAL MAP.
 THIS MAP WAS CREATED FOR THE IMPERIAL COUNTY
 ASSESSOR, FOR THE SOLE PURPOSE OF AIDING IN
 THE PERFORMANCE OF THE DUTIES OF THE ASSESSOR.
 ANY ERRORS OR OMISSIONS IN THIS MAP ARE NOT
 THE RESPONSIBILITY OF THE COUNTY OF IMPERIAL
 OR THE ASSESSOR. (REV. & TAX CODE SEC.327)

Date	By	Revision
10-18-52	R.M.	Blow-up & Revision of Bk.57 Pg.44-Portion Sheet 6 of 6 Sheets



MEXICO
 BAJA CALIFORNIA

Assessor's Map Bk.59-Pg.30
 County of Imperial, Calif.

RECORDING REQUESTED BY
Fidelity National Title Company
WHEN RECORDED MAIL TO:
=addressee=

ORDER NO.: 30053824-997-ML6

SPACE ABOVE THIS LINE FOR RECORDER'S USE

CERTIFICATION OF TRUST
California Probate Code Section 18100.5

The undersigned declare(s) under penalty of perjury under the laws of the State of California that the following is true and correct:

1. The Trust known as _____,
executed on _____, is a valid and existing trust.
2. The name(s) of the settlor(s) of the Trust is (are): _____

3. The name(s) of the currently acting trustee(s) is (are): _____

4. The trustee(s) of the Trust have the following powers (initial applicable line(s)):
_____ Power to acquire additional property.
_____ Power to sell and execute deeds.
_____ Power to encumber, and execute deeds of trust.
_____ Other: _____
5. The Trust is (check one): _____ Revocable _____ Irrevocable
The name of the person who may revoke the Trust is: _____
6. The number of trustees who must sign documents in order to exercise the powers of the Trust is (are): _____,
whose name(s) is (are): _____
7. Title to Trust assets is to be taken as follows: _____
8. The Trust has not been revoked, modified or amended in any manner which would cause the representations
contained herein to be incorrect.
9. I (we) am (are) all of the currently acting trustees.
10. I (we) understand that I (we) may be required to provide copies of excerpts from the original Trust documents
which designate the trustees and confer the power to act in the pending transaction.

Dated: _____

(Acknowledgement must be attached)

CERTIFICATE OF ACKNOWLEDGEMENT OF NOTARY PUBLIC

A notary public or other officer completing this certificate verifies only the identity of the individual who signed the document to which this certificate is attached, and not the truthfulness, accuracy, or validity of that document.

STATE OF CALIFORNIA
COUNTY OF

} SS:

On _____ before me,

a Notary Public, personally appeared _____

who proved to me on the basis of satisfactory evidence to be the person(s) whose name(s) is/are subscribed to the within instrument and acknowledged to me that he/she/they executed the same in his/her/their authorized capacity(ies) and that by his/her/their signature(s) on the instrument the person(s), or the entity upon behalf of which the person(s) acted, executed the instrument.

I certify under PENALTY OF PERJURY under the laws of the State of California that the foregoing paragraph is true and correct.

WITNESS my hand and official seal.

Signature _____

CERTIFICATE OF ACKNOWLEDGEMENT OF NOTARY PUBLIC

A notary public or other officer completing this certificate verifies only the identity of the individual who signed the document to which this certificate is attached, and not the truthfulness, accuracy, or validity of that document.

STATE OF CALIFORNIA
COUNTY OF

} SS:

On _____ before me,

a Notary Public, personally appeared _____

who proved to me on the basis of satisfactory evidence to be the person(s) whose name(s) is/are subscribed to the within instrument and acknowledged to me that he/she/they executed the same in his/her/their authorized capacity(ies) and that by his/her/their signature(s) on the instrument the person(s), or the entity upon behalf of which the person(s) acted, executed the instrument.

I certify under PENALTY OF PERJURY under the laws of the State of California that the foregoing paragraph is true and correct.

WITNESS my hand and official seal.

Signature _____

RECORDING REQUESTED BY
Fidelity National Title Company
WHEN RECORDED MAIL TO:
=addressee=

ORDER NO.: **30053824-997-ML6**

SPACE ABOVE THIS LINE FOR RECORDER'S USE

CERTIFICATION OF TRUST
California Probate Code Section 18100.5

The undersigned declare(s) under penalty of perjury under the laws of the State of California that the following is true and correct:

1. The Trust known as _____,
executed on _____, is a valid and existing trust.
2. The name(s) of the settlor(s) of the Trust is (are): _____

3. The name(s) of the currently acting trustee(s) is (are): _____

4. The trustee(s) of the Trust have the following powers (initial applicable line(s)):
_____ Power to acquire additional property.
_____ Power to sell and execute deeds.
_____ Power to encumber, and execute deeds of trust.
_____ Other: _____
5. The Trust is (check one): _____ Revocable _____ Irrevocable
The name of the person who may revoke the Trust is: _____
6. The number of trustees who must sign documents in order to exercise the powers of the Trust is (are): _____,
whose name(s) is (are): _____
7. Title to Trust assets is to be taken as follows: _____
8. The Trust has not been revoked, modified or amended in any manner which would cause the representations
contained herein to be incorrect.
9. I (we) am (are) all of the currently acting trustees.
10. I (we) understand that I (we) may be required to provide copies of excerpts from the original Trust documents
which designate the trustees and confer the power to act in the pending transaction.

Dated: _____

(Acknowledgement must be attached)

CERTIFICATE OF ACKNOWLEDGEMENT OF NOTARY PUBLIC

A notary public or other officer completing this certificate verifies only the identity of the individual who signed the document to which this certificate is attached, and not the truthfulness, accuracy, or validity of that document.

STATE OF CALIFORNIA
COUNTY OF

} SS:

On _____ before me,

a Notary Public, personally appeared _____

who proved to me on the basis of satisfactory evidence to be the person(s) whose name(s) is/are subscribed to the within instrument and acknowledged to me that he/she/they executed the same in his/her/their authorized capacity(ies) and that by his/her/their signature(s) on the instrument the person(s), or the entity upon behalf of which the person(s) acted, executed the instrument.

I certify under PENALTY OF PERJURY under the laws of the State of California that the foregoing paragraph is true and correct.

WITNESS my hand and official seal.

Signature _____

CERTIFICATE OF ACKNOWLEDGEMENT OF NOTARY PUBLIC

A notary public or other officer completing this certificate verifies only the identity of the individual who signed the document to which this certificate is attached, and not the truthfulness, accuracy, or validity of that document.

STATE OF CALIFORNIA
COUNTY OF

} SS:

On _____ before me,

a Notary Public, personally appeared _____

who proved to me on the basis of satisfactory evidence to be the person(s) whose name(s) is/are subscribed to the within instrument and acknowledged to me that he/she/they executed the same in his/her/their authorized capacity(ies) and that by his/her/their signature(s) on the instrument the person(s), or the entity upon behalf of which the person(s) acted, executed the instrument.

I certify under PENALTY OF PERJURY under the laws of the State of California that the foregoing paragraph is true and correct.

WITNESS my hand and official seal.

Signature _____

OWNER'S DECLARATION

Escrow No.: 30053824-997-MAT-ML6
Property Address: APN'S #059-300-015-000, 059-300-017-000 and 059-290-010-000
County of Imperial, CA

The undersigned hereby declares as follows:

1. (Fill in the applicable paragraph and strike the other)
 - a. Declarant ("Owner") is the owner or lessee, as the case may be, of certain premises located at APN'S #059-300-015-000, 059-300-017-000 and 059-290-010-000, County of Imperial, CA, further described as follows: See Preliminary Report/Commitment No. for full legal description (the "Land").
 - b. Declarant is the _____ of _____ ("Owner"), which is the owner or lessee, as the case may be, of certain premises located at APN'S #059-300-015-000, 059-300-017-000 and 059-290-010-000, County of Imperial, CA, further described as follows: See Preliminary Report/Commitment No. for full legal description (the "Land").
2. (Fill in the applicable paragraph and strike the other)
 - a. During the period of six months immediately preceding the date of this declaration no work has been done, no surveys or architectural or engineering plans have been prepared, and no materials have been furnished in connection with the erection, equipment, repair, protection or removal of any building or other structure on the Land or in connection with the improvement of the Land in any manner whatsoever.
 - b. During the period of six months immediately preceding the date of this declaration certain work has been done and materials furnished in connection with _____ upon the Land in the approximate total sum of \$_____, but no work whatever remains to be done and no materials remain to be furnished to complete the construction in full compliance with the plans and specifications, nor are there any unpaid bills incurred for labor and materials used in making such improvements or repairs upon the Land, or for the services of architects, surveyors or engineers, except as follows: _____, Owner, by the undersigned Declarant, agrees to and does hereby indemnify and hold harmless Fidelity National Title Company against any and all claims arising therefrom.
3. Owner has not previously conveyed the Land; is not a debtor in bankruptcy (and if a partnership, the general partner thereof is not a debtor in bankruptcy); and has not received notice of any pending court action affecting the title to the Land.
4. Except as shown in the above-referenced Preliminary Report/Commitment, there are no unpaid or unsatisfied mortgages, deeds of trust, Uniform Commercial Code financing statements, regular assessments, special assessments, periodic assessments or any assessment from any source, claims of lien, special assessments, or taxes that constitute a lien against the Land or that affect the Land but have not been recorded in the public records. There are no violations of the covenants, conditions and restrictions as shown in the above-referenced Preliminary Report/Commitment.
5. The Land is currently in use as _____; _____ occupy/occupies the Land; and the following are all of the leases or other occupancy rights affecting the Land:

6. There are no other persons or entities that assert an ownership interest in the Land, nor are there unrecorded easements, claims of easement, or boundary disputes that affect the Land.
7. There are no outstanding options to purchase or rights of first refusal affecting the Land.
8. Between the most recent Effective Date of the above-referenced Preliminary Report/Commitment and the date of recording of the Insured Instrument(s), Owner has not taken or allowed, and will not take or allow, any action or inaction to encumber or otherwise affect title to the Land.

This declaration is made with the intention that Fidelity National Title Company (the "Company") and its policy issuing agents will rely upon it in issuing their title insurance policies and endorsements. Owner, by the undersigned Declarant, agrees to indemnify the Company against loss or damage (including attorneys fees, expenses, and costs) incurred by the Company as a result of any untrue statement made herein.

I declare under penalty of perjury that the foregoing is true and correct and that this declaration was executed on _____ at _____.

Signature: _____

APPENDIX H

PC ORIGINAL PKG



780 N. 4th Street
El Centro, CA 92243
(760) 337-1100

Phase I Environmental Site Assessment (ESA) User Questionnaire

- 1) **Environmental liens that are filed or recorded against the *property*.**
Did a search of *recorded land title records* (or judicial records where appropriate) identify any environmental liens filed or recorded against the *property* under federal, tribal, state, or local law?

Not to our knowledge.

- 2) **Activity and use limitations that are in place on the *property* or that have been filed or recorded against the *property*.**
Did a search of *recorded land title records* (or judicial records where appropriate) identify any AULs, such as *engineering controls*, land use restrictions or *institutional controls* that are in place at the property and/or have been filed or recorded against the *property* under federal, tribal, state or local law?

Not to our knowledge.

- 3) **Specialized knowledge or experience of the person seeking to qualify for the LLP.**
Do you have any specialized knowledge or experience related to the *property* or nearby properties? For example, are you involved in the same line of business as the current or former occupants of the *property* or an *adjoining property* so that you would have specialized knowledge of the chemicals and processes used by this type of business?

No.

4) **Relationship of the purchase price to the fair market value of the *property* if it were not contaminated.**

Does the purchase price being paid for this *property* reasonable reflect the fair market value of the *property*? If you conclude that there is a difference, have you considered whether the lower purchase price is because contamination is known or believed to be present at the *property*?

Yes.

5) **Commonly known or *reasonably ascertainable* information about the *property*.**

Are you aware of commonly known or *reasonably ascertainable* information about the *property* that would help the *environmental professional* to identify conditions indicative of releases or threatened releases? For example,

- a. Do you know the past uses of the *property*?

Vacant Land

- b. Do you know of specific chemicals or oils that are present or once were present at the *property*?

None that we know of or suspect.

- c. Do you know of spills or other chemical releases that have taken place at the *property*?

None that we know of or suspect.

- d. Do you know of any environmental cleanups that have taken place at the *property*?

None that we know of or suspect.

6) **The degree of obviousness of the presence or likely presence of contamination at the *property*, and the ability to detect the contamination by appropriate investigation.**

Based on your knowledge and experience related to the *property* are there any *obvious* indicators that point to the presence or likely presence of releases at the *property*?

None that we know of or suspect.

Additional Information

1) Reason why Phase I ESA is required:

Conditional Use Permit for proposed development project.

2) Type of Property:

Commercial
Industrial
Residential
Vacant/Undeveloped
Other Fallowed farmland

Type of Transaction:

Purchase
Financing
Sale
Lease
Other _____

3) Complete and correct address for the property:

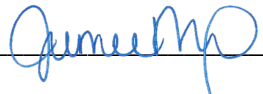
No situs. APN's 059-300-015-000, 059-300-017-000 and 059-290-010-000

4) Are there any existing environmental report, documents, correspondence, etc. available for review?

None.

User Name/Company: Jamie Nagel/Apex Energy Solutions, LLC

Address: 604 Sutter Street, Suite 250
Folsom, CA 95630

User Signature: 

Date: 12/10/2020

5 DD9 B8 ± ' =

PC ORIGINAL PKG



**Steven K. Williams, CEG
Senior Engineering Geologist**

Education

M.S. Geology
University of Utah, 1993
B.S. Geology
University of Utah, 1989

Registration

Registered Geologist
Arizona 3759
California 6975
Certified Engineering Geologist
California 2261

Professional Experience

2000 – Present Project Geologist
GS Lyon Consultants, Inc.
1994 - 2000 Staff Geologist
GS Lyon Consultants, Inc.
1994 Field Geologist
Bureau of Land Management
1991 - 1992 Exploration Geologist
Kennecott Corporation

Summary of Experience

Mr. Williams has performed geotechnical investigations in southern California and southwestern Arizona. His field experience includes logging of soil borings and exploratory trenches, collection and documentation of soil samples, collection of field geotechnical data, and monitoring pile driving operations. Mr. Williams is also responsible for preparing computer generated data and figures, drafting and subsequent writing of geotechnical reports for a variety of projects including road improvements, fault studies, liquefaction potential evaluation, foundation preparation, seepage studies, structural distress, and soil investigations. He has performed geotechnical, geologic, and environmental studies for a wide variety of projects including correctional facilities, water and wastewater facilities, schools, residential subdivisions, commercial developments, and landfills throughout southern California and southwestern Arizona.

Mr. Williams also performs Phase I Environmental Site Assessments throughout the Imperial and Coachella Valleys. The scope of work for these projects typically include a site reconnaissance, review of government records pertaining to previous site uses, and preparation of a report identifying potential environmental risks.

He also conducts investigations for the potential of asbestos-containing materials and lead-based paint in old building projects and potential for soil contamination by hydrocarbons, pesticides, and other hazardous materials.

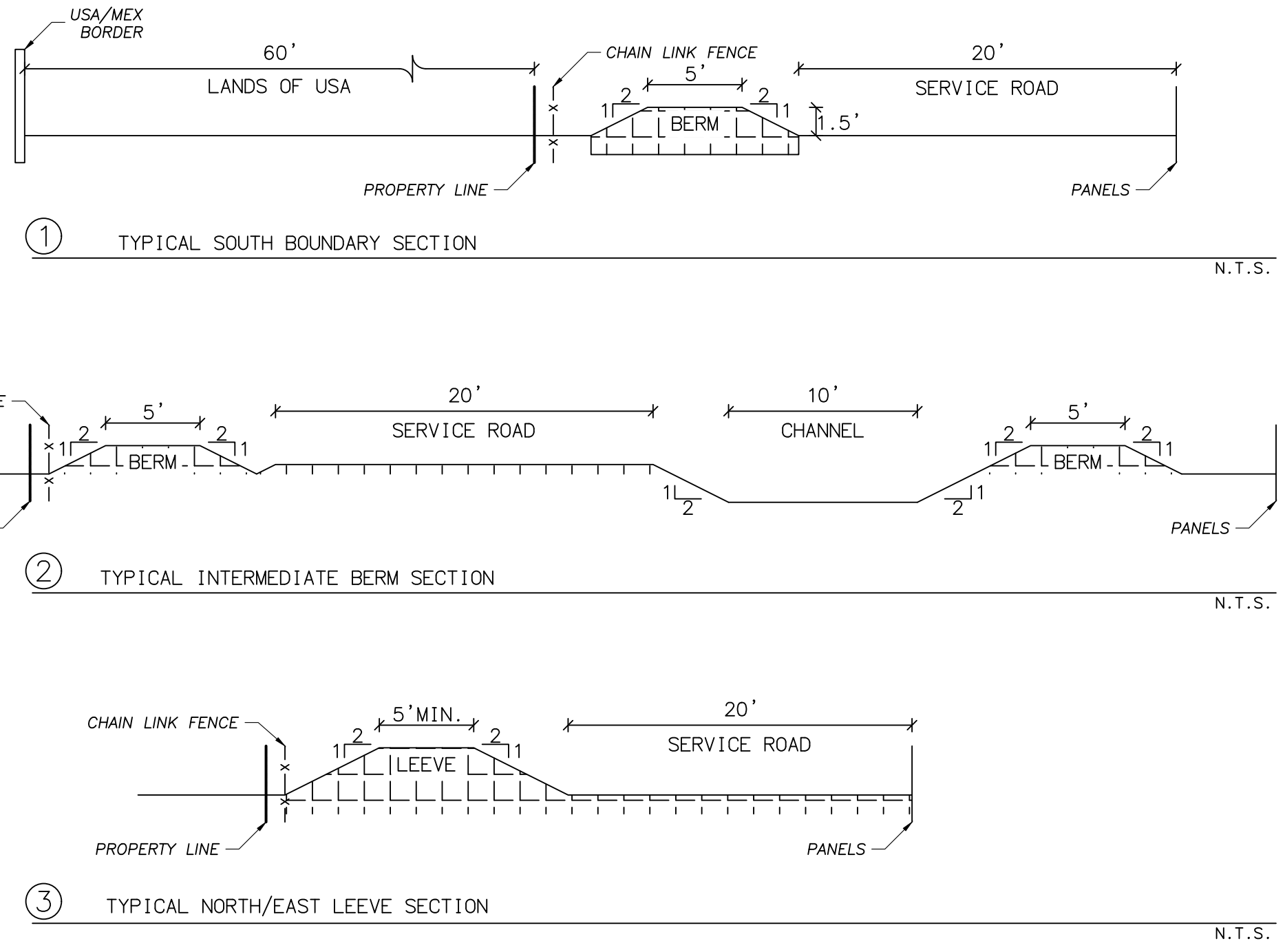
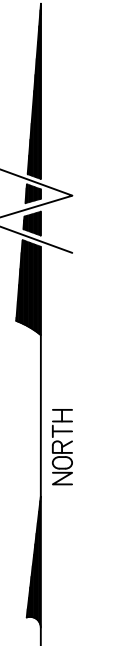
Professional Affiliations

Geological Society of America, Member

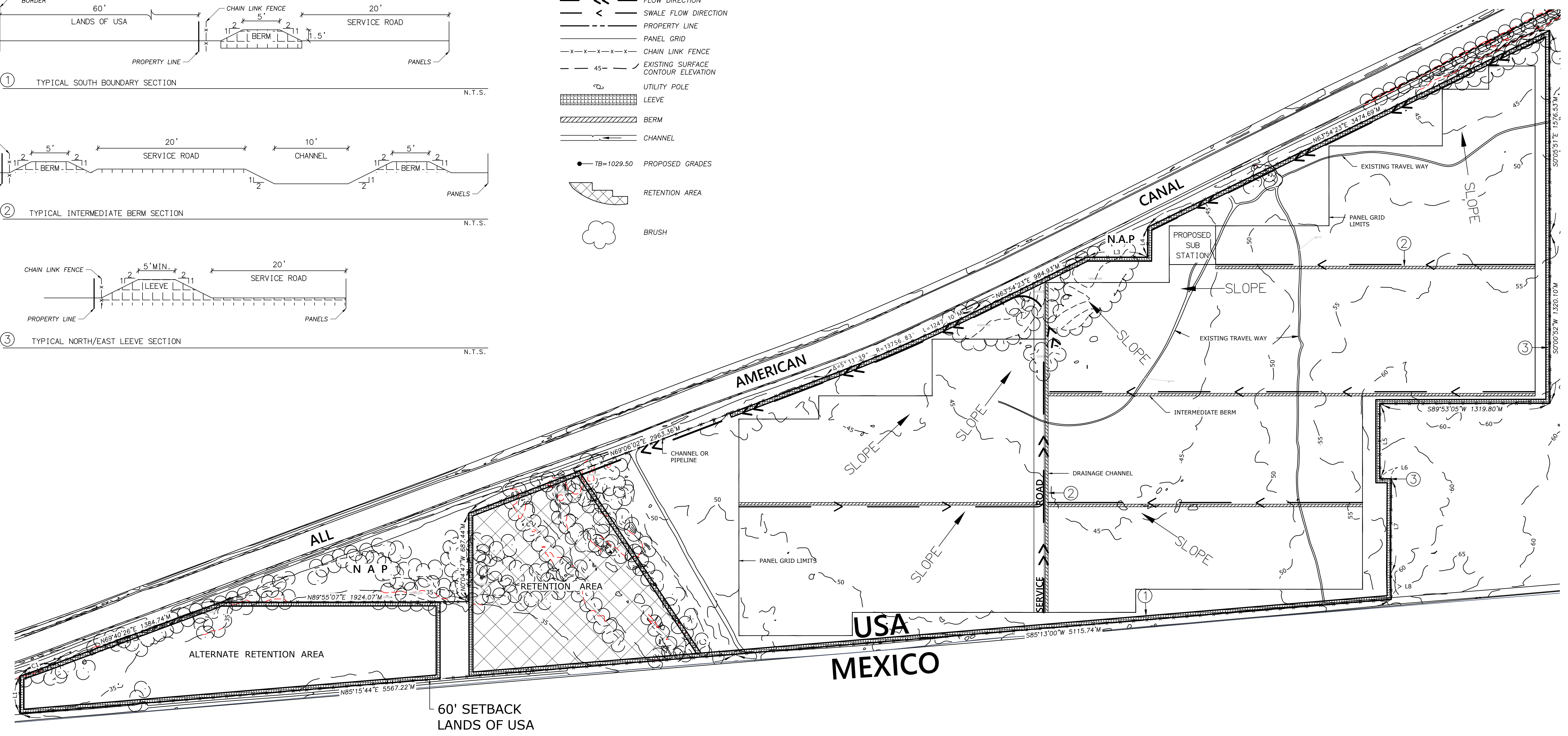
Selected Project Experience

- **El Centro Seniors Apartments, El Centro, CA**
Performed Phase I and Phase II environmental site assessments for apartment complex at old school district office site with underground storage tanks.
- **Central Main Canal Seepage Study, Imperial, CA**
Conducted 6-month groundwater seepage study for Imperial Irrigation District to evaluate high groundwater levels in Sandalwood Glen Subdivision
- **Gateway to the Americas, Calexico, CA**
Conducted Phase I ESA, geologic hazards study and geotechnical investigation including liquefaction evaluation for 1,700 acre development associated with new Port of Entry east of Calexico
- **El Centro Magistrate Court, El Centro, CA**
Conducted geotechnical investigation and Phase I ESA for new Federal Magistrate Court building at site with soft soil conditions requiring foundation settlement analysis
- **El Centro Regional Medical Center, El Centro, CA**
Conducted Phase I ESA and geotechnical investigation for 50,000 sf, 2-story addition to the medical center's emergency room, operating rooms, and recovery rooms.
- **Brawley Union High School, Brawley, CA**
Conducted Phase II investigation for PCB and lead contamination of surficial soil and hydrocarbon contamination of subsurface soil of a property proposed for purchase.
- **EW Corporation Site, Westmorland, CA**
Conducted Phase II investigation for hydrocarbon contamination of subsurface soil of a service station site with leaking underground storage tanks prior to property purchase
- **Various Apartment Complexes, Imperial County, CA**
Conducted Phase I environmental investigation at numerous proposed apartment complex site within the Imperial Valley
- **Oasis Elementary School, Mecca, CA**
Conducted PEA environmental investigation for the new Oasis Elementary School prior to construction of school

PRELIMINARY GRADING PLAN



- LEGEND**
- << — FLOW DIRECTION
 - < — SWALE FLOW DIRECTION
 - - - - - PROPERTY LINE
 - - - - - PANEL GRID
 - x - x - x - CHAIN LINK FENCE
 - - - 45 - - EXISTING SURFACE CONTOUR ELEVATION
 - ⊙ UTILITY POLE
 - ▨ LEEVE
 - ▨ BERM
 - CHANNEl
 - TB=1029.50 PROPOSED GRADES
 - ☁ RETENTION AREA
 - ☁ BRUSH



VERTICAL BENCHMARK
 NGS STATION: BR 3 16 A NGS PID: DB0416
 BENCHMARK ELEVATION= 50.78'
 NGS BENCHMARK LOCATION:
 FROM THE INTERSECTION OF STATE HWY 115 AND U.S. 80 IN HOLTVILLE PROCEED SOUTH ABOUT 7 MILES TO THE INTERSECTION OF STATE HIGHWAYS 115 AND 98, KNOWN AS BONDS CORNER, THEN PROCEED EAST ON HIGHWAY 98 3.2 MILES. THE MARK IS LOCATED APPROXIMATELY 400 FEET SOUTH OF THE HIGHWAY AND IS SET ON THE CENTERLINE OF THE EAST WHEEL GUARD OF THE BRIDGE AT THE EAST HIGHLINE CHECK AT THE POINT WHERE THE EAST HIGHLINE CANAL IS DIVERTED FROM THE ALL AMERICAN CANAL. SECTION 1 T17S, R16E.

INCREMENTAL INCREASE IN STORM WATER VOLUMES
 NUMBER OF ESTIMATED PANEL FRAME FOUNDATIONS: 85 BLOCKS X 3200 PANELS = 272,800 FOUNDATIONS.
 ASSUME 0.25 S.F. PER FOUNDATION: TOTAL FOUNDATION AREA = 0.25(272,800) = 68,000 S.F.
 AREA OF FOUNDATIONS IN ELECTRICAL SUBSTATION = 10,000 S.F.
 TOTAL INCREMENTAL RUNOFF = 0.25 FT. (68,000 S.F. + 10,000 S.F.) = 19,500 CU. FT.
 i = 3" STORM (100 YEAR)
 A = 520 ACRES (SOLAR FARM AREA)
 C = 1.0 PER COUNTY STANDARD
 Q = CIA
 Q = 1.0(0.25) 520AC
 Q = 130 AC FT. = 5,662,800 C.F. + 19,500 C.F. = 5,682,300 C.F.
RETENTION AREA
 WEST SIDE = 800' AVERAGE WIDTH X 7.9' AVERAGE DEPTH X 900' LENGTH = 5,688,000 C.F. > 5,682,300 C.F. ∴ OK

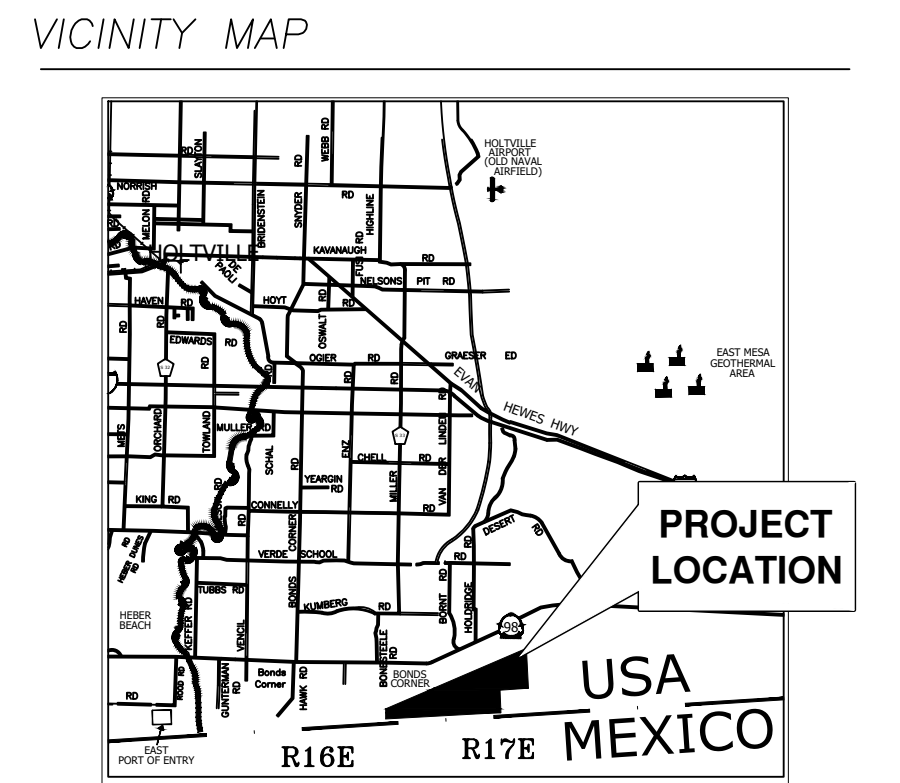
- NOTES**
- THE HORIZONTAL AND VERTICAL CONTROL WAS PERFORMED BY PRECISION ENGINEERING AND SURVEYING IN OCTOBER, 2020.
 - THE AERIAL PHOTOGRAPHY WAS PERFORMED BY COOPER AERIAL ON OCTOBER 16, 2020
 - SOLAR FARM PANEL AREA IS 324 ACRES.
 - NO ADJUSTMENTS HAVE BEEN MADE TO THE PANEL LAYOUT OR LEEVE LOCATION FOR ENVIRONMENTAL ISSUES. THIS WOULD INCLUDE WETLANDS, RIPARIAN HABITAT OR CULTURAL LOCATIONS. MINOR MODIFICATIONS MAY BE REQUIRED.

FEMA NOTE
 AS SHOWN ON THIS SURVEY, PART OF THE SUBJECT LAND IS LOCATED IN A 100-YEAR FLOOD PLAIN OR IN AN IDENTIFIED "FLOOD PRONE AREA", AS DEFINED PURSUANT TO THE FLOOD DISASTER PROTECTION ACT OF 1973, AS AMENDED, AS REFLECTED BY FLOOD INSURANCE RATE MAP PANEL #06025C2125C DATED SEPTEMBER 26, 2008. THE SUBJECT PARCEL IS LOCATED IN ZONE "X."

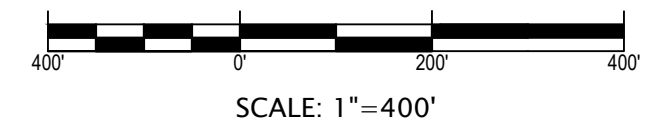
GRADING / DRAINAGE METHODOLOGY
 THE DOYLE RANCH SOLAR FARM PROJECT IS APPROXIMATELY 521 GROSS ACRES SOUTH OF THE ALL AMERICAN CANAL AND NORTH OF THE MEXICO BOUNDARY, OF WHICH 510 ACRES WILL BE DEVELOPED. THE DEVELOPED AREA WILL BE SURROUNDED BY A LEEVE THAT WILL PROTECT THE PANELS. A LEEVE DESIGNED FOR A 100 YEAR EVENT WILL DIVERT THE STORMWATER AROUND THE SITE TO FLOW TO THE RETENTION AREA.
 THE DEVELOPED PANEL AREA WILL HAVE RETENTION AREAS OUTSIDE THE ALL AMERICAN CANAL RIGHT OF WAY ON THE NORTH SIDE OF THE PROJECT. THE RETENTION AREA SHOULD BE DESIGNED MINIMAL FOR THE INCREMENTAL INCREASE IN STORMWATER CAUSED BY THE PANEL SUPPORTS.
 ALL THE STORMWATER IS PROPOSED TO REMAIN ON SITE.

LINE TABLE			
#	BEARINGS	LENGTH	REF.
L1	N0°01'40"E	291.80'	M
L2	N0°12'49"W	631.85'	M
L3	S89°58'41"E	473.41'	M
L4	N0°21'06"E	232.74'	M
L5	S0°01'05"E	581.39'	M
L6	N89°56'50"E	88.08'	M
L7	N0°19'18"E	737.95'	M
L8	N0°11'59"W	199.78'	M

CURVE TABLE				
#	DELTA	RADIUS	LENGTH	REF.
C1	01°21'59"	11659.20'	278.06'	M



DOYLE
 PORTION OF SECTIONS 10, 11 & 12, T17S-R16E S.B.M.



GRADING PLAN FOR APEX ENERGY: SES 4 LOCATION: PORTIONS OF SECTIONS 10, 11 AND 12 IN T.17S.-R.16E. S.B.M. Precision Engineering & Surveying, Inc. P.O. Box 2216 Telephone: (760) 353-2684 El Centro, CA 92244 (760) 353-2684 799 E. Hill Avenue Fax: (760) 353-2686 El Centro, CA 92243	SHEET No. 1 OF 1 SHEETS DRAWN BY: C.D. DATE: 01/18/2021 REVISED: 03/16/2021 JOB No. 20-142
-------------------------------------------------------------------------------------------------------------------------------------------------------------------------------------------------------------------------------------------------------------------------------------------------------------------------	---------------------------------------------------------------------------------------------------------------------

PRINTED: 03/16/2021

PC ORIGINAL PKG

Noise Impact Assessment

Vega SES 4 Solar Energy Storage Project

County of Imperial, California

Prepared For:

Vega SES 4, LLC
604 Sutter Street
Suite 250
Folsom, California 95630

February 2021



ECORP Consulting, Inc.
ENVIRONMENTAL CONSULTANTS

PC ORIGINAL PKG

CONTENTS

1.0 INTRODUCTION 1

 1.1 Project Overview..... 1

 1.2 Project Location..... 1

 1.3 Applicable Land Use Regulations 1

 1.4 Project Site Access..... 2

 1.5 Project Construction 2

2.0 ENVIRONMENTAL NOISE AND GROUNDBORNE VIBRATION ANALYSIS..... 4

 2.1 Fundamentals of Noise and Environmental Sound..... 4

 2.1.1 Addition of Decibels..... 4

 2.1.2 Sound Propagation and Attenuation 6

 2.1.3 Noise Descriptors 7

 2.1.4 Human Response to Noise..... 9

 2.1.5 Effects of Noise on People..... 9

 2.2 Fundamentals of Environmental Groundborne Vibration 10

 2.2.1 Vibration Sources and Characteristics..... 10

3.0 EXISTING ENVIRONMENTAL NOISE SETTING..... 11

 3.1 Noise-Sensitive Land Uses 11

 3.2 Existing Ambient Noise Environment..... 12

4.0 REGULATORY FRAMEWORK..... 12

 4.1 Federal..... 12

 4.1.1 Occupational Safety and Health Act of 1970 12

 4.2 State 13

 4.2.1 State of California General Plan Guidelines 13

 4.2.2 State Office of Planning and Research Noise Element Guidelines 13

 4.3 Local 13

 4.3.1 Imperial County General Plan Noise Element..... 13

5.0 IMPACT ASSESSMENT 17

 5.1 Thresholds of Significance..... 17

 5.2 Methodology 17

 5.3 Impact Analysis 18

 5.3.1 Project Construction Noise..... 18

 5.3.2 Project Operational Noise..... 20

 5.3.3 Project Construction Groundborne Vibration..... 24

 5.3.4 Project Operational Groundborne Vibration..... 25

5.3.5 Excess Airport Noise..... 25
5.3.6 Cumulative Noise 26
6.0 REFERENCES..... 27

LIST OF TABLES

Table 2-1. Common Acoustical Descriptors.....8
Table 2-2. Human Reaction and Damage to Buildings for Continuous or Frequent Intermittent Vibration Levels 11
Table 3-1. Existing (Baseline) Noise Measurements 12
Table 4-1. County of Imperial Property Line Noise Standards..... 19
Table 4-2. County of Imperial Noise Land Use Compatibility Guidelines..... 16
Table 5-1. Construction Average (dBA) Noise/Levels at Nearest Receptor 19
Table 5-2. Modeled Operational Noise Levels at Nearest Sensitive Receptor 22
Table 5-3. Representative Vibration Source Levels for Construction Equipment..... 24
Table 5-4. Construction Vibration Levels at 100 Feet 25

LIST OF FIGURES

Figure 1. Project Location and Vicinity.....3
Figure 2. Common Noise Levels.....5
Figure 3. Project Onsite Source Noise Generation..... 23

ATTACHMENTS

- Attachment A - Baseline (Existing) Noise Measurements – Project Site and Vicinity
- Attachment B - Federal Highway Administration Highway Roadway Construction Noise Outputs – Project Construction Noise
- Attachment C - SoundPLAN Outputs – Onsite Project Noise

LIST OF ACRONYMS AND ABBREVIATIONS

CEQA	California Environmental Quality Act
CNEL	Community Noise Equivalent Level
dB	Decibel
dBA	Decibel is A-weighted
FHWA	Federal Highway Administration

FTA	Federal Transit Administration
L_{eq}	Measure of ambient noise
OPR	Office of Planning and Research
OSHA	Federal Occupational Safety and Health Administration
OSHPD	Office of State Health Planning and Development
PPV	Peak particle velocity
Project	Vega SES 4 Solar Energy Storage Project
A-3-RE	Heavy Agriculture with a Renewable Energy Overlay
RMS	Root mean square
SR	State Route
WEAL	Western Electro-Acoustic Laboratory, Inc.
Aqueduct	All-American Canal

1.0 INTRODUCTION

This report documents the results of a Noise Impact Assessment completed for the Vega SES 4 Solar Energy Storage Project (Project), which includes the construction of a nominal 100-megawatt alternating current (MWAC) solar photovoltaic (PV) energy generation system with an integrated 100 MW battery storage project on approximately 531.53 acres of land in the County of Imperial, California. This report was prepared as a comparison of predicted Project noise levels to noise standards promulgated by the County of Imperial General Plan Noise Element. The purpose of this report is to estimate Project-generated noise and to determine the level of impact the Project would have on the environment.

1.1 Project Overview

The Project proposes to construct a nominal 100 MWAC PV energy generation system, accompanied by a 100 MW battery storage, utilizing either thin film or crystalline solar PV technology modules mounted either on fixed frames or horizontal single-axis tracker (HSAT) systems. The fixed frame PV module arrays would be mounted on racks that would be supported by driven piles. The individual PV systems would be arranged in large arrays by placing them in columns spaced approximately ten feet apart to maximize operational performance and to allow access for panel cleaning and maintenance.

1.2 Project Location

The Project site is an approximately 531.53-acre site located between the California/Mexico border and the All-American Canal (Aqueduct), on the California side in southcentral Imperial County (see Figure 1). The Project site is located approximately 1.92 miles southeast of the Bonds Corner Rd/East Cedar Street/California State Route 98 intersection near the unincorporated community of Bonds Corner. The Project would be located on Imperial County Assessor's Parcel Numbers (APNs) 059-300-015-000 (approximately 301.73 acres), 059-300-017-000 (approximately 148.88 acres) and 059-290-010-000 (approximately 80.92 acres). The irregular shaped site is bound by undeveloped agricultural land to the south, west and east, and the Aqueduct running southwest on the northern border of the proposed Project site. The Project site is currently characterized by flat and undeveloped agricultural land.

1.3 Applicable Land Use Regulations

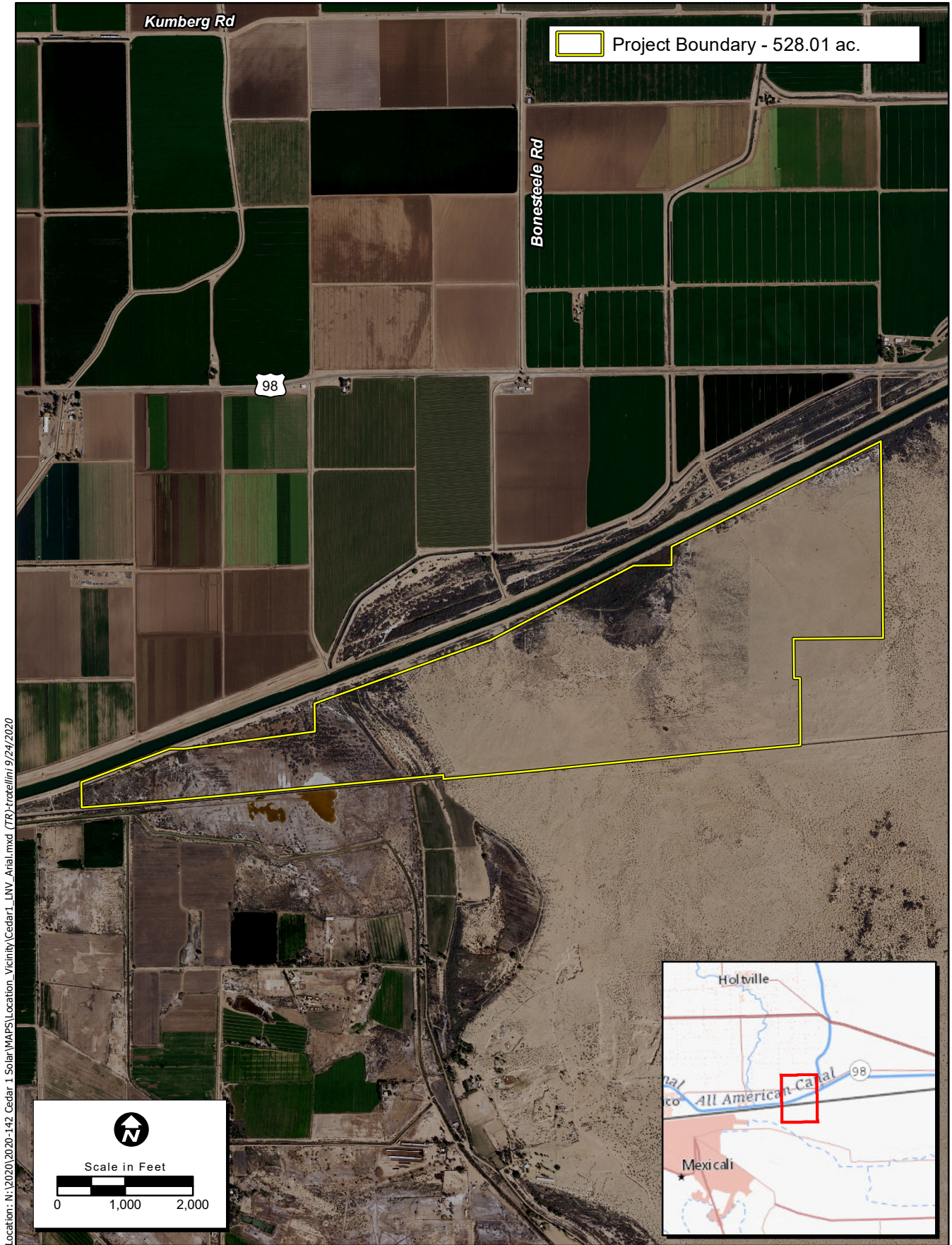
All three of the Project area parcels are designated as "Agriculture" in the Imperial County General Plan and are zoned A-3-RE (Heavy Agriculture with a Renewable Energy Overlay-areas that are suitable for agricultural land uses; to prevent the encroachment of incompatible uses onto and within agricultural lands; and to prohibit the premature conversion of such lands to non-agricultural uses). Pursuant to Section 91703.02 (CONDITIONAL USE PERMITS), Renewable Energy Projects must be located within the Renewable Energy Overlay Zone and may be permitted only through the issuance of a Conditional Use Permit (CUP) as approved by the Approving Authority unless otherwise allowed by applicable law. At present, the Project is located within the Renewable Energy Zone

1.4 Project Site Access

The Project site would include one primary access driveway, currently contemplated across the East Highline Check of the Aqueduct, in the far northeastern corner of the Project area and a secondary access driveway (if required) with a to-be-determined location . This driveway would be provided with a minimum of 30-foot double swing gates with "Knox Box" for keyed entry. Internal to the Project site up to 30-foot wide roads would be provided between the PV arrays, as well as around the perimeter of each Project site inside the perimeter security fence to provide access to all areas of each site for maintenance and emergency vehicles.

1.5 Project Construction

Construction activities would primarily involve demolition and grubbing; grading of the Project area to establish access roads and pads for electrical equipment (inverters and step-up transformers); trenching for underground electrical collection lines; and the installation of solar equipment and security fencing. The construction of the site is estimated to take 12-18 months and would begin in 2022. A temporary, portable construction supply container would be located at the Project site at the beginning of construction and removed at the end of construction. The number of on-site construction workers for the solar project facilities is not expected to exceed 150 workers at any one time. The number of on-site construction workers for the battery storage facility and the substation is not expected to exceed 100 workers at any one time. Onsite parking would be provided for all construction workers.



Location: N:\2020\2020-142_Cedar_1_Solar\WAPS\Location_Vicinity\Cedar1_LINV_Arial.mxd (TR)-truelin 9/24/2020

Map Date: 9/24/2020
 Service Layer Credits:
 Photo Source: NAIP (2018)

Figure 1. Project Location and Vicinity

2020-142 Vega SES 4

2.0 ENVIRONMENTAL NOISE AND GROUNDBORNE VIBRATION ANALYSIS

2.1 Fundamentals of Noise and Environmental Sound

2.1.1 Addition of Decibels

The decibel (dB) scale is logarithmic, not linear, and therefore sound levels cannot be added or subtracted through ordinary arithmetic. Two sound levels 10 dB apart differ in acoustic energy by a factor of 10. When the standard logarithmic decibel is A-weighted (dBA), an increase of 10 dBA is generally perceived as a doubling in loudness. For example, a 70-dBA sound is half as loud as an 80-dBA sound and twice as loud as a 60-dBA sound. When two identical sources are each producing sound of the same loudness, the resulting sound level at a given distance would be three dB higher than one source under the same conditions (Federal Transit Administration [FTA] 2018). For example, a 65-dB source of sound, such as a truck, when joined by another 65 dB source results in a sound amplitude of 68 dB, not 130 dB (i.e., doubling the source strength increases the sound pressure by three dB). Under the decibel scale, three sources of equal loudness together would produce an increase of five dB.

Typical noise levels associated with common noise sources are depicted in Figure 2. *Common Noise Levels*

Common Outdoor Activities	Noise Level (dBA)	Common Indoor Activities
<u>Jet Fly-over at 300m (1000 ft)</u>	110	<u>Rock Band</u>
<u>Gas Lawn Mower at 1 m (3 ft)</u>	100	
<u>Diesel Truck at 15 m (50 ft), at 80 km (50 mph)</u>	90	<u>Food Blender at 1 m (3 ft)</u>
<u>Noisy Urban Area, Daytime</u>	80	<u>Garbage Disposal at 1 m (3 ft)</u>
<u>Gas Lawn Mower, 30 m (100 ft)</u>	70	<u>Vacuum Cleaner at 3 m (10 ft)</u>
<u>Commercial Area</u>		<u>Normal Speech at 1 m (3 ft)</u>
<u>Heavy Traffic at 90 m (300 ft)</u>	60	<u>Large Business Office</u>
<u>Quiet Urban Daytime</u>	50	<u>Dishwasher Next Room</u>
<u>Quiet Urban Nighttime</u>	40	<u>Theater, Large Conference Room (Background)</u>
<u>Quiet Suburban Nighttime</u>		<u>Library</u>
<u>Quiet Rural Nighttime</u>	30	<u>Bedroom at Night,</u>
	20	<u>Concert Hall (Background)</u>
	10	<u>Broadcast/Recording Studio</u>
<u>Lowest Threshold of Human Hearing</u>	0	<u>Lowest Threshold of Human Hearing</u>

Source: California Department of Transportation (Caltrans) 2020a



2.1.2 Sound Propagation and Attenuation

Noise can be generated by a number of sources, including mobile sources such as automobiles, trucks and airplanes, and stationary sources such as construction sites, machinery, and industrial operations. Sound spreads (propagates) uniformly outward in a spherical pattern, and the sound level decreases (attenuates) at a rate of approximately six dB for each doubling of distance from a stationary or point source. Sound from a line source, such as a highway, propagates outward in a cylindrical pattern, often referred to as cylindrical spreading. Sound levels attenuate at a rate of approximately three dB for each doubling of distance from a line source, such as a roadway, depending on ground surface characteristics (Federal Highway Administration [FHWA] 2011). No excess attenuation is assumed for hard surfaces like a parking lot or a body of water. Soft surfaces, such as soft dirt or grass, can absorb sound, so an excess ground-attenuation value of 1.5 dB per doubling of distance is normally assumed. For line sources, an overall attenuation rate of three dB per doubling of distance is assumed (FHWA 2011).

Noise levels may also be reduced by intervening structures; generally, a single row of detached buildings between the receptor and the noise source reduces the noise level by about five dBA (FHWA 2006), while a solid wall or berm generally reduces noise levels by 10 to 20 dBA (FHWA 2011). However, noise barriers or enclosures specifically designed to reduce site-specific construction noise can provide a sound reduction 35 dBA or greater (Western Electro-Acoustic Laboratory, Inc. [WEAL] 2000). To achieve the most potent noise-reducing effect, a noise enclosure/barrier must physically fit in the available space, must completely break the "line of sight" between the noise source and the receptors, must be free of degrading holes or gaps, and must not be flanked by nearby reflective surfaces. Noise barriers must be sizable enough to cover the entire noise source and extend lengthwise and vertically as far as feasibly possible to be most effective. The limiting factor for a noise barrier is not the component of noise transmitted through the material, but rather the amount of noise flanking around and over the barrier. In general, barriers contribute to decreasing noise levels only when the structure breaks the "line of sight" between the source and the receiver.

The manner in which older homes in California were constructed generally provides a reduction of exterior-to-interior noise levels of about 20 to 25 dBA with closed windows (Caltrans 2002). The exterior-to-interior reduction of newer residential units is generally 30 dBA or more (Harris Miller, Miller & Hanson Inc. [HMMH] 2006). Generally, in exterior noise environments ranging from 60 dBA Community Noise Equivalent Level (CNEL) to 65 dBA CNEL, interior noise levels can typically be maintained below 45 dBA, a typically residential interior noise standard, with the incorporation of an adequate forced air mechanical ventilation system in each residential building, and standard thermal-pane residential windows/doors with a minimum rating of Sound Transmission Class (STC) 28. (STC is an integer rating of how well a building partition attenuates airborne sound. In the U.S., it is widely used to rate interior partitions, ceilings, floors, doors, windows, and exterior wall configurations.) In exterior noise environments of 65 dBA CNEL or greater, a combination of forced-air mechanical ventilation and sound-rated construction methods is often required to meet the interior noise level limit. Attaining the necessary noise reduction from exterior to interior spaces is readily achievable in noise environments less than 75 dBA CNEL with proper wall construction techniques following California Building Code methods, the selections of proper windows and doors, and the incorporation of forced-air mechanical ventilation systems.

2.1.3 Noise Descriptors

The decibel scale alone does not adequately characterize how humans perceive noise. The dominant frequencies of a sound have a substantial effect on the human response to that sound. Several rating scales have been developed to analyze the adverse effect of community noise on people. Because environmental noise fluctuates over time, these scales consider that the effect of noise on people is largely dependent on the total acoustical energy content of the noise, as well as the time of day when the noise occurs. The L_{eq} is a measure of ambient noise, while the L_{dn} and CNEL (Community Noise Equivalent Level) are measures of community noise. Each is applicable to this analysis and defined in Table 2-1.

Table 2-1. Common Acoustical Descriptors	
Descriptor	Definition
Decibel, dB	A unit describing the amplitude of sound, equal to 20 times the logarithm to the base 10 of the ratio of the pressure of the sound measured to the reference pressure. The reference pressure for air is 20.
Sound Pressure Level	Sound pressure is the sound force per unit area, usually expressed in micropascals (or 20 micronewtons per square meter), where 1 pascal is the pressure resulting from a force of 1 newton exerted over an area of 1 square meter. The sound pressure level is expressed in decibels as 20 times the logarithm to the base 10 of the ratio between the pressures exerted by the sound to a reference sound pressure (e.g., 20 micropascals). Sound pressure level is the quantity that is directly measured by a sound level meter.
Frequency, Hertz (Hz)	The number of complete pressure fluctuations per second above and below atmospheric pressure. Normal human hearing is between 20 Hz and 20,000 Hz. Infrasonic sound are below 20 Hz and ultrasonic sounds are above 20,000 Hz.
A-Weighted Sound Level, dBA	The sound pressure level in decibels as measured on a sound level meter using the A weighting filter network. The A-weighting filter de-emphasizes the very low and very high frequency components of the sound in a manner similar to the frequency response of the human ear and correlates well with subjective reactions to noise.
Equivalent Noise Level, L_{eq}	The average acoustic energy content of noise for a stated period of time. Thus, the L_{eq} of a time-varying noise and that of a steady noise are the same if they deliver the same acoustic energy to the ear during exposure. For evaluating community impacts, this rating scale does not vary, regardless of whether the noise occurs during the day or the night.
L_{max} , L_{min}	The maximum and minimum A-weighted noise level during the measurement period.
L_{01} , L_{10} , L_{50} , L_{90}	The A-weighted noise levels that are exceeded 1%, 10%, 50%, and 90% of the time during the measurement period.
Day/Night Noise Level, L_{dn} or DNL	A 24-hour average L_{eq} with a 10 dBA “weighting” added to noise during the hours of 10:00 p.m. to 7:00 a.m. to account for noise sensitivity in the nighttime. The logarithmic effect of these additions is that a 60 dBA 24-hour L_{eq} would result in a measurement of 66.4 dBA L_{dn} .
Community Noise Equivalent Level, CNEL	A 24-hour average L_{eq} with a 5 dBA “weighting” during the hours of 7:00 p.m. to 10:00 p.m. and a 10 dBA “weighting” added to noise during the hours of 10:00 p.m. to 7:00 a.m. to account for noise sensitivity in the evening and nighttime, respectively. The logarithmic effect of these additions is that a 60 dBA 24-hour L_{eq} would result in a measurement of 66.7 dBA CNEL.
Ambient Noise Level	The composite of noise from all sources near and far. The normal or existing level of environmental noise at a given location.
Intrusive	That noise which intrudes over and above the existing ambient noise at a given location. The relative intrusiveness of a sound depends on its amplitude, duration, frequency, and time of occurrence and tonal or informational content as well as the prevailing ambient noise level.
Decibel, dB	A unit describing the amplitude of sound, equal to 20 times the logarithm to the base 10 of the ratio of the pressure of the sound measured to the reference pressure. The reference pressure for air is 20.

The A weighted decibel sound level scale gives greater weight to the frequencies of sound to which the human ear is most sensitive. Because sound levels can vary markedly over a short period of time, a method for describing either the average character of the sound or the statistical behavior of the variations must be utilized. Most commonly, environmental sounds are described in terms of an average level that has the same acoustical energy as the summation of all the time-varying events.

The scientific instrument used to measure noise is the sound level meter. Sound level meters can accurately measure environmental noise levels to within about ± 1 dBA. Various computer models are used to predict environmental noise levels from sources, such as roadways and airports. The accuracy of the predicted models depends on the distance between the receptor and the noise source. Close to the noise source, the models are accurate to within about ± 1 to 2 dBA.

2.1.4 Human Response to Noise

The human response to environmental noise is subjective and varies considerably from individual to individual. Noise in the community has often been cited as a health problem, not in terms of actual physiological damage, such as hearing impairment, but in terms of inhibiting general well-being and contributing to undue stress and annoyance. The health effects of noise in the community arise from interference with human activities, including sleep, speech, recreation, and tasks that demand concentration or coordination. Hearing loss can occur at the highest noise intensity levels.

Noise environments and consequences of human activities are usually well represented by median noise levels during the day or night or over a 24-hour period. Environmental noise levels are generally considered low when the CNEL is below 60 dBA, moderate in the 60 to 70 dBA range, and high above 70 dBA. Examples of low daytime levels are isolated, natural settings with noise levels as low as 20 dBA and quiet, suburban, residential streets with noise levels around 40 dBA. Noise levels above 45 dBA at night can disrupt sleep. Examples of moderate-level noise environments are urban residential or semi-commercial areas (typically 55 to 60 dBA) and commercial locations (typically 60 dBA). People may consider louder environments adverse, but most will accept the higher levels associated with noisier urban residential or residential-commercial areas (60 to 75 dBA) or dense urban or industrial areas (65 to 80 dBA). Regarding increases in A-weighted noise levels (dBA), the following relationships should be noted in understanding this analysis:

- Except in carefully controlled laboratory experiments, a change of 1 dBA cannot be perceived by humans.
- Outside of the laboratory, a 3-dBA change is considered a just-perceivable difference.
- A change in level of at least 5 dBA is required before any noticeable change in community response would be expected. An increase of 5 dBA is typically considered substantial.
- A 10-dBA change is subjectively heard as an approximate doubling in loudness and would almost certainly cause an adverse change in community response.

2.1.5 Effects of Noise on People

Hearing Loss

While physical damage to the ear from an intense noise impulse is rare, a degradation of auditory acuity can occur even within a community noise environment. Hearing loss occurs mainly due to chronic exposure to excessive noise but may be due to a single event such as an explosion. Natural hearing loss associated with aging may also be accelerated from chronic exposure to loud noise.

The Occupational Safety and Health Administration (OSHA) has a noise exposure standard that is set at the noise threshold where hearing loss may occur from long-term exposures. The maximum allowable level is 90 dBA averaged over eight hours. If the noise is above 90 dBA, the allowable exposure time is correspondingly shorter.

Annoyance

Attitude surveys are used for measuring the annoyance felt in a community for noises intruding into homes or affecting outdoor activity areas. In these surveys, it was determined that causes for annoyance include interference with speech, radio and television, house vibrations, and interference with sleep and rest. The L_{dn} as a measure of noise has been found to provide a valid correlation of noise level and the percentage of people annoyed. People have been asked to judge the annoyance caused by aircraft noise and ground transportation noise. There continues to be disagreement about the relative annoyance of these different sources. For ground vehicles, a noise level of about 55 dBA L_{dn} is the threshold at which a substantial percentage of people begin to report annoyance.

2.2 Fundamentals of Environmental Groundborne Vibration

2.2.1 Vibration Sources and Characteristics

Sources of earthborne vibrations include natural phenomena (e.g., earthquakes, volcanic eruptions, sea waves, landslides) or manmade causes (explosions, machinery, traffic, trains, construction equipment, etc.). Vibration sources may be continuous (e.g., factory machinery) or transient (e.g., explosions).

Ground vibration consists of rapidly fluctuating motions or waves with an average motion of zero. Several different methods are typically used to quantify vibration amplitude. One is the peak particle velocity (PPV); another is the root mean square (RMS) velocity. The PPV is defined as the maximum instantaneous positive or negative peak of the vibration wave. The RMS velocity is defined as the average of the squared amplitude of the signal. The PPV and RMS vibration velocity amplitudes are used to evaluate human response to vibration.

PPV is generally accepted as the most appropriate descriptor for evaluating the potential for building damage. For human response, however, an average vibration amplitude is more appropriate because it takes time for the human body to respond to the excitation (the human body responds to an average vibration amplitude, not a peak amplitude). Because the average particle velocity over time is zero, the RMS amplitude is typically used to assess human response. The RMS value is the average of the amplitude squared over time, typically a 1- sec. period (FTA 2018).

Table 2-2 displays the reactions of people and the effects on buildings produced by continuous vibration levels. The annoyance levels shown in the table should be interpreted with care since vibration may be found to be annoying at much lower levels than those listed, depending on the level of activity or the sensitivity of the individual. To sensitive individuals, vibrations approaching the threshold of perception can be annoying. Low-level vibrations frequently cause irritating secondary vibration, such as a slight rattling of windows, doors, or stacked dishes. The rattling sound can give rise to exaggerated vibration complaints, even though there is very little risk of actual structural damage. In high-noise environments,

which are more prevalent where groundborne vibration approaches perceptible levels, this rattling phenomenon may also be produced by loud airborne environmental noise causing induced vibration in exterior doors and windows.

Ground vibration can be a concern in instances where buildings shake, and substantial rumblings occur. However, it is unusual for vibration from typical urban sources such as buses and heavy trucks to be perceptible. For instance, heavy-duty trucks generally generate groundborne vibration velocity levels of 0.006 PPV at 50 feet under typical circumstances, which as identified in Table 2-2 is considered very unlikely to cause damage to buildings of any type. Common sources for groundborne vibration are planes, trains, and construction activities such as earth-moving which requires the use of heavy-duty earth moving equipment.

Peak Particle Velocity (inches/second)	Approximate Vibration Velocity Level (VdB)	Human Reaction	Effect on Buildings
0.006–0.019	64–74	Range of threshold of perception	Vibrations unlikely to cause damage of any type
0.08	87	Vibrations readily perceptible	Recommended upper level to which ruins and ancient monuments should be subjected
0.1	92	Level at which continuous vibrations may begin to annoy people, particularly those involved in vibration sensitive activities	Virtually no risk of architectural damage to normal buildings
0.2	94	Vibrations may begin to annoy people in buildings	Threshold at which there is a risk of architectural damage to normal dwellings
0.4–0.6	98–104	Vibrations considered unpleasant by people subjected to continuous vibrations and unacceptable to some people walking on bridges	Architectural damage and possibly minor structural damage

Source: Caltrans 2020b

3.0 EXISTING ENVIRONMENTAL NOISE SETTING

3.1 Noise-Sensitive Land Uses

Noise-sensitive land uses are generally considered to include those uses where noise exposure could result in health-related risks to individuals, as well as places where quiet is an essential element of their intended purpose. Residential dwellings are of primary concern because of the potential for increased and prolonged exposure of individuals to both interior and exterior noise levels. Additional land uses such as hospitals, historic sites, cemeteries, and certain recreation areas are considered sensitive to increases in exterior noise levels. Schools, churches, hotels, libraries, and other places where low interior noise levels are essential are also considered noise-sensitive land uses.

The nearest existing noise-sensitive land use to the Project site is a single-family residence located 1,342 feet from the northeastern corner of Project site.

3.2 Existing Ambient Noise Environment

The Project site consists of flat undeveloped land and is bound by agricultural land to the north with State Route (SR) 98 beyond, agricultural land to the west, vacant undisturbed land to the east, and a mix of vacant undisturbed and agricultural land to the south. In order to quantify existing ambient noise levels in the Project area, ECORP Consulting, Inc. conducted three short-term noise measurements on January 12th, 2021. The noise measurement sites were representative of typical existing noise exposure within and adjacent to the Project site during the daytime (see Attachment A for a visual depiction of the Noise Measurement Locations). The 15-minute measurements were taken between 1:51 p.m. and 2:45 p.m. Short-term (L_{eq}) measurements are considered representative of the noise levels throughout the day. As shown in Table 3-1, the existing noise levels (Baseline) in the Project-vicinity ranges from 65.4 to 68.7 dBA.

Location Number	Location	L_{eq} dBA	L_{min} dBA	L_{max} dBA	Time
1	CA-98 East of Bonds Corner Rd	65.4	36.3	79.8	2:30 p.m.- 2:45 p.m.
2	CA-98 East of Bonesteel Rd	68.7	25.2	86.2	2:10 p.m. – 2:25 p.m.
3	CA-98 Southeastern Extent	66.1	40.8	81.5	1:51 p.m. – 2:06 p.m.

Source: Measurements were taken by ECORP with a Larson Davis LxT SE precision sound level meter, which satisfies the American National Standards Institute for general environmental noise measurement instrumentation. See Attachment A for noise measurement outputs.

The most common noise in the Project vicinity is produced by automotive vehicles (e.g., cars, trucks, buses, motorcycles) traversing SR 98. Traffic moving along streets produces a sound level that remains relatively constant and is part of the minimum ambient noise level in the project vicinity. Vehicular noise varies with the volume, speed and type of traffic. Slower traffic produces less noise than fast-moving traffic. Trucks typically generate more noise than cars. Infrequent or intermittent noise also is associated with vehicles, including sirens, vehicle alarms, slamming of doors, trains, garbage and construction vehicle activity and honking of horns. These noises add to urban noise and are regulated by a variety of agencies.

4.0 REGULATORY FRAMEWORK

4.1 Federal

4.1.1 Occupational Safety and Health Act of 1970

OSHA regulates onsite noise levels and protects workers from occupational noise exposure. To protect hearing, worker noise exposure is limited to 90 decibels with A-weighting (dBA) over an eight-hour work shift (29 Code of Regulations 1910.95). Employers are required to develop a hearing conservation

program when employees are exposed to noise levels exceeding 85 dBA. These programs include provision of hearing protection devices and testing employees for hearing loss on a periodic basis.

4.2 State

4.2.1 State of California General Plan Guidelines

The State of California regulates vehicular and freeway noise affecting classrooms, sets standards for sound transmission and occupational noise control, and identifies noise insulation standards and airport noise/land-use compatibility criteria. The State of California General Plan Guidelines (State of California 2003), published by the Governor's Office of Planning and Research (OPR), also provides guidance for the acceptability of projects within specific CNEL/ L_{dn} contours. The guidelines also present adjustment factors that may be used in order to arrive at noise acceptability standards that reflect the noise control goals of the community, the particular community's sensitivity to noise, and the community's assessment of the relative importance of noise pollution.

4.2.2 State Office of Planning and Research Noise Element Guidelines

The State OPR *Noise Element Guidelines* include recommended exterior and interior noise level standards for local jurisdictions to identify and prevent the creation of incompatible land uses due to noise. The Noise Element Guidelines contain a Land Use Compatibility table that describes the compatibility of various land uses with a range of environmental noise levels in terms of the CNEL.

4.3 Local

4.3.1 Imperial County General Plan Noise Element

The County of Imperial General Plan Noise Element establishes maximum allowable average-hourly noise limits for various land use designations (refer to Table 4-1). These noise standards are to be applied at the property line of the noise-generating land use. In instances where the adjoining land use designations differ from that of the noise-generating land use, the more restrictive noise standard shall apply. Where the ambient noise level is equal to or exceeds the property line noise standard, the increase of the existing or proposed noise shall not exceed 3 dBA L_{eq} , which is a just-perceivable increase in noise. L_{eq} is defined as the average acoustic energy content of noise for a stated period of time. Thus, the L_{eq} of a time-varying noise and that of a steady noise are the same if they deliver the same acoustic energy to the ear during exposure.

Land Use Zone	Time Period	Average-Hourly Noise Level (dBA L_{eq})
Residential	7 a.m. - 10 p.m.	50
	10 p.m. - 7 a.m.	45
Multi-residential	7 a.m. - 10 p.m.	55
	10 p.m. - 7 a.m.	50
Commercial	7 a.m. - 10 p.m.	60
	10 p.m. - 7 a.m.	55
Light Industrial/Industrial Park	Any time	70
General Industrial	Any time	75

Source: Imperial County 2015.

Notes: When the noise-generating property and the receiving property have different uses, the more restrictive standard shall apply. When the ambient noise level is equal to or exceeds the Property Line noise standard, the increase of the existing or proposed noise shall not exceed 3 dBA L_{eq}.

Construction Noise Standards

Construction noise, from a single piece of equipment or a combination of equipment, shall not exceed 75 dB L_{eq}, when averaged over an eight (8) hour period, and measured at the nearest sensitive receptor. This standard assumes a construction period, relative to an individual sensitive receptor of days or weeks. In cases of extended length construction times, the standard may be tightened so as not to exceed 75 dB L_{eq} when averaged over a one (1) hour period.

Construction equipment operation are required to be limited to the hours of 7:00 a.m. to 7:00 p.m., Monday through Friday, and 9:00 a.m. to 5:00 p.m. Saturday. No commercial construction operations are permitted on Sunday or holidays. In cases of a person constructing or modifying a residence for himself/herself, and if the work is not being performed as a business, construction equipment operations may be performed on Sundays and holidays between the hours of 9:00 a.m. and 5:00 p.m. Such non-commercial construction activities may be further restricted where disturbing, excessive, or offensive noise causes discomfort or annoyance to reasonable persons of normal sensitivity residing in an area.

Significant Increase of Ambient Noise Levels

The increase of noise levels generally results in an adverse impact to the noise environment. The Noise/Land Use Compatibility Guidelines are not intended to allow the increase of ambient noise levels up to the maximum without consideration of feasible noise reduction measures. The following guidelines are established by the County of Imperial for the evaluation of significant noise impact.

- If the future noise level after a project is completed will be within the "normally acceptable" noise levels shown in the Noise/Land Use Compatibility Guidelines, but will result in an increase of 5 dB CNEL or greater, the project will have a potentially significant noise impact and mitigation measures must be considered.
- If the future noise level after a project is completed will be greater than the "normally acceptable" noise levels shown in the Noise/Land Use Compatibility Guidelines, a noise increase of 3 dB CNEL

or greater shall be considered a potentially significant noise impact and mitigation measures must be considered.

Noise/Land Use Compatibility

The Imperial County General Plan Noise Element Noise/Land Use Compatibility Standards defines the acceptability of a land use in a specified noise environment. Table 4-2 provides the County of Imperial Noise/Land Use Compatibility Guidelines. When an acoustical analysis is performed, conformance of the proposed project with the Noise/Land Use Compatibility Guidelines will be used to evaluate potential noise impact and will provide criteria for environmental impact findings and conditions for project approval.

Table 4-2. County of Imperial Noise/Land Use Compatibility Guidelines		
Land Use Category	Community Noise Exposure L_{dn} or CNEL, dB	Acceptability
Residential	< 60	Normally Acceptable
	60 - 70	Conditionally Acceptable
	70 - 75	Normally Unacceptable
	> 75	Clearly Unacceptable
Transient Lodging-Motels, Hotels	< 60	Normally Acceptable
	60 - 75	Conditionally Acceptable
	75 - 80	Normally Unacceptable
	> 80	Clearly Unacceptable
Schools, Libraries, Churches, Hospitals, Nursing Homes	< 60	Normally Acceptable
	60 - 70	Conditionally Acceptable
	70 - 80	Normally Unacceptable
	> 80	Clearly Unacceptable
Auditoriums, Concert Halls, Amphitheaters	< 70	Conditionally Acceptable
	> 70	Clearly Unacceptable
Sports Arenas, Outdoor Spectator Sports	< 70	Conditionally Acceptable
	70 - 75	Normally Unacceptable
	> 75	Clearly Unacceptable
Playgrounds, Neighborhood Parks	< 70	Normally Acceptable
	70 - 75	Normally Unacceptable
	> 75	Clearly Unacceptable
Golf Courses, Riding Stables, Water Recreation, Cemeteries	< 70	Normally Acceptable
	70 - 80	Normally Unacceptable
	> 80	Clearly Unacceptable
Office Buildings, Business Commercial and Professional	< 65	Normally Acceptable
	65 - 75	Conditionally Acceptable
	75 - 80	Normally Unacceptable
	> 80	Clearly Unacceptable
Industrial, Manufacturing Utilities, Agriculture	< 70	Normally Acceptable
	70 - 75	Conditionally Acceptable
	75 - 80	Normally Unacceptable
	> 80	Clearly Unacceptable

Source: Imperial County 2015.

Notes: Interpretation (For Land Use Planning Purposes):

Normally Acceptable: Specified land use is satisfactory, based upon the assumption that any buildings involved are of normal conventional construction, without any special noise insulation requirements.

Conditionally Acceptable: New construction or development should be undertaken only after a detailed analysis of the noise reduction requirements is made and needed noise insulation features included in the design

Normally Unacceptable: New construction or development should be discouraged. If new construction or development does proceed, a detailed analysis of the noise reduction requirements must be made and needed noise insulation features included in the design.

Clearly Unacceptable: New construction or development clearly should not be undertaken.

5.0 IMPACT ASSESSMENT

5.1 Thresholds of Significance

The impact analysis provided below is based on the following California Environmental Quality Act Guidelines Appendix G thresholds of significance. The project would result in a significant noise-related impact if it would produce:

- 1) Generation of a substantial temporary or permanent increase in ambient noise levels in the vicinity of the project in excess of standards established in the local general plan or noise ordinance, or applicable standards of other agencies.
- 2) Generation of excessive groundborne vibration or groundborne noise levels.
- 3) For a project located within the vicinity of a private airstrip or an airport land use plan or, where such a plan has not been adopted, within two miles of a public airport or public use airport, would the project expose people residing or working in the project area to excessive noise levels.

For purposes of this analysis, Project construction noise is compared to the County's construction noise standard of 75 dBA, when averaged over an eight (8) hour period and measured at the nearest sensitive receptor. Noise generated onsite is compared against the County's property line standards identified in Table 4-1.

5.2 Methodology

This analysis of the existing and future noise environments is based on empirical observations. Predicted construction noise levels were calculated utilizing the FHWA's Roadway Construction Model (2006). Groundborne vibration levels associated with construction-related activities for the Project have been evaluated utilizing typical groundborne vibration levels associated with construction equipment. Potential groundborne vibration impacts related to structural damage and human annoyance were evaluated, taking into account the distance from construction activities to nearby structures and typically applied criteria for structural damage and human annoyance.

In order to estimate the worst-case operational noise levels that may occur at the nearest noise-sensitive receptor, onsite operational noise levels have been calculated with the SoundPLAN 3D noise model (which predicts noise propagation from a noise source based on the location, noise level, and frequency spectra of the noise sources as well as the geometry and reflective properties of the local terrain, buildings, and barriers), coupled with noise measurements that were taken by ECORP Consulting, Inc. (ECORP) at an existing solar energy generation facility. Specifically, ECORP conducted a 30-minute reference noise measurement within the IVC solar generation facility in Imperial County with a Larson Davis SoundExpert LxT precision sound-level meter, which satisfies the American National Standards Institute for general environmental noise measurement instrumentation. This reference measurement identified an ambient noise environment of 47.1 dBA at the existing solar energy generation facility (see Attachment C).

Therefore, a noise level of 47.1 dBA was employed as the reference noise level in the SoundPLAN 3D noise model to determine noise-level propagation associated with Project operations.

5.3 Impact Analysis

5.3.1 Project Construction Noise

Would the Project Result in Short-Term Construction-Generated Noise in Excess of Standards?

Onsite Construction Noise

Construction noise associated with the proposed Project would be temporary and would vary depending on the nature of the activities being performed. Noise generated would primarily be associated with the operation of off-road equipment for onsite construction activities as well as construction vehicle traffic on area roadways. Construction noise typically occurs intermittently and varies depending on the nature or phase of construction (e.g., land clearing, grading, excavation, paving). Noise generated by construction equipment, including earth movers, material handlers, and portable generators, can reach high levels. Typical operating cycles for these types of construction equipment may involve one or two minutes of full power operation followed by three to four minutes at lower power settings. Other primary sources of acoustical disturbance would be random incidents, which would last less than one minute (such as dropping large pieces of equipment or the hydraulic movement of machinery lifts). During construction, exterior noise levels could negatively affect sensitive land uses in the vicinity of the construction site.

Nearby noise-sensitive land uses consist of a scattering of single-family residential units located within 1 mile of the proposed Project site boundary to the north across the Aqueduct. The closest sensitive receptor is located 1,342 feet from the northeastern corner of the Project site. As previously described, the County's General Plan Noise Element states construction equipment operation shall be limited to the hours of 7:00 a.m. to 7:00 p.m., Monday through Friday, and 9:00 a.m. to 5:00 p.m. on Saturdays. No commercial construction operations are permitted on Sundays or holidays. Construction noise, from a single piece of equipment or a combination of equipment, shall not exceed 75 dB L_{eq} , when averaged over an eight (8) hour period, and measured at the nearest sensitive receptor. This standard assumes a construction period, relative to an individual sensitive receptor of days or weeks. In cases of extended length construction times, the standard may be tightened so as not to exceed 75 dB L_{eq} when averaged over a one (1) hour period.

The anticipated short-term construction noise levels generated for the necessary construction equipment are presented in Table 5-1.

Table 5-1. Construction Average (dBA) Noise Levels at Nearest Receptor			
Equipment	Estimated Exterior Construction Noise Level at Existing Residences	Construction Noise Standards (dBA L_{eq})	Exceeds Standards?
Site Preparation			
Rubber Tired Dozers (2)	46.6 (each)	75	No
Tractors/Loaders/Backhoes (2)	51.4 (each)	75	No
Combined Site Preparation Equipment	55.7	75	No
Grading			
Excavators (4)	48.2 (each)	75	No
Graders (3)	52.4 (each)	75	No
Rubber Tired Dozers (2)	49.1 (each)	75	No
Scrapers (2)	51 (each)	75	No
Tractors/Loaders/Backhoes (4)	51.4 (each)	75	No
Combined Grading Equipment	62.5	75	No
Facility Construction			
Crane	44	75	No
Paver	45.6	75	No
Paving Equipment (2)	53.9 (each)	75	No
Pile Drivers (4)	65.7 (each)	75	No
Rollers (2)	44.4 (each)	75	No
Rough Terrain Forklifts (4)	50.8 (each)	75	No
Tractors/Loaders/Backhoes (4)	51.4 (each)	75	No
Trenchers (2)	48.8 (each)	75	No
Combined Construction, Trenching, & Paving	72.2	75	No

Source: Construction noise levels were calculated by ECRP Consulting using the FHWA Roadway Noise Construction Model (FHWA 2006). Refer to Attachment B for Model Data Outputs.

Notes: The nearest residence is located approximately 1,342 feet from the Project boundary.

L_{eq} = The equivalent energy noise level, is the average acoustic energy content of noise for a stated period of time. Thus, the L_{eq} of a time-varying noise and that of a steady noise are the same if they deliver the same acoustic energy to the ear during exposure. For evaluating community impacts, this rating scale does not vary, regardless of whether the noise occurs during the day or the night.

As shown in Table 5-1, no individual or cumulative pieces of construction equipment would exceed the 75 dBA County construction noise standard during any phase of construction at the nearby noise-sensitive receptors.

Offsite Construction Worker Traffic Noise

Project construction would result in additional traffic on adjacent roadways over the time period that construction occurs. As previously stated, the number of on-site construction workers for the solar project facilities is not expected to exceed 150 workers at any one time. The number of on-site construction workers for the battery storage facility and the substation is not expected to exceed 100 workers at any one time. Onsite parking would be provided for all construction workers. According to KOA Corporation (2020), a maximum of 510 daily automobile trips would be generated during Project construction, accounting for construction worker commutes and equipment deliveries. The majority of these trips are expected to be accommodated on SR 98, SR 7, and Interstate 8. According to the California Department of Transportation (Caltrans) *Technical Noise Supplement to the Traffic Noise Analysis Protocol* (2013), doubling of traffic on a roadway is required to result in an increase of 3 dB (outside of the laboratory, a 3-dBA change is considered a just-perceivable difference). According to the Caltrans Traffic Census Program (2018), SR 98 currently accommodates 2,400 average daily traffic trips, while SR 7 and Interstate 8 accommodate 6,700 average daily trips and 14,000 average daily trips, respectively. Thus, the estimated 510 daily trips during Project construction would not result in a doubling of traffic on these facilities, and its contribution to existing traffic noise would not be perceptible. Bonds Corner Road and W. Heber Road are also projected to accommodate construction-related traffic with an estimated 69 daily trips on Bonds Corner Road and 5 daily trips on W. Heber Road over the course of construction. These two facilities are classified as "minor arterial" roads by the County General Plan Circulation and Scenic Highways Element (2008) which are expected to accommodate approximately 14,800 daily trips. While the Circulation and Scenic Highways Element does not identify specific traffic counts for Bonds Corner Road, it estimates between 2,020 and 16,700 average daily trips on W. Heber Road.

The Project construction would not result in a doubling of traffic, and therefore its contribution to existing traffic noise would not be perceptible.

5.3.2 Project Operational Noise**Would the Project Result in a Substantial Permanent Increase in Ambient Noise Levels in Excess of County or City Standards During Operations?**

As previously described, noise-sensitive land uses are locations where people reside or where the presence of unwanted sound could adversely affect the use of the land. Residences, schools, hospitals, guest lodging, libraries, and some passive recreation areas would each be considered noise-sensitive and may warrant unique measures for protection from intruding noise. The nearest existing noise-sensitive land use to the Project site is a single-family residential unit located approximately 1,342 feet north of the proposed Project site boundary, across the Aqueduct.

Operational Offsite Traffic Noise

Project operations would result in minimal additional traffic on adjacent roadways. The only visitors to the site would be that of repair or maintenance workers, whose presence at the site would be necessary infrequently and inconsistently. According to the California Department of Transportation (Caltrans) *Technical Noise Supplement to the Traffic Noise Analysis Protocol* (2013), doubling of traffic on a roadway

is required to result in an increase of 3 dB (outside of the laboratory, a 3-dBA change is considered a just-perceivable difference). The proposed Project would not result in a doubling of traffic, and therefore its contribution to existing traffic noise would not be perceptible.

Project Land Use Compatibility

The County uses the land use compatibility standards presented in the General Plan Noise Element that provides the County with a tool to gauge the compatibility of new land uses relative to existing noise levels. This table, presented as Table 4-2, identifies acceptable noise levels for various land uses. In the case that the noise levels identified at the proposed Project site fall within the “acceptable” levels presented in the General Plan, the Project is considered compatible with the existing noise environment.

As previously stated, the Project site is proposing to develop a 100 MWAC PV solar energy generation and storage facility. The proposed Project site is zoned A-3-RE (Heavy Agriculture with a Renewable Energy Overlay). As shown in Table 4-2, a normally acceptable noise standard for agricultural land uses is 69 dBA CNEL or under. In order to quantify existing ambient noise levels in the Project area, ECORP conducted three short-term noise measurements on January 12th, 2021. The noise measurement sites were representative of typical existing noise exposure in the Project vicinity and are considered representative of the noise levels throughout the day. As shown in Table 3-1, the ambient noise level recorded in the vicinity of the Project site ranges from 65.4 dBA to 68.7 dBA. However, it is noted that these short-term measurements were each conducted over 1,000 feet from the Project site and adjacent to SR 98, a substantial noise source. Thus, the ambient noise levels experienced on the actual Project site would most likely be less.

Additionally, according to Table 4 of the County General Plan Noise Element (2015), the segment of SR 98 traversing the Project site currently experiences noise levels of 60 dBA CNEL at 33 feet. Since the site is over 1,000 feet south of SR 98 and there are no consistent sources of noise in between the Project site and SR 98, it can be assumed that noise levels on the Project site are less than 60 dBA CNEL. SR 98 is the dominate source of noise in the Project vicinity. This General Plan Noise Element data is reported in the noise metric, CNEL, which is the same noise metric promulgated by County noise compatibility guidelines contained in Table 4-2. As these noise levels fall below the noise standard, the Project site is considered an appropriate noise environment to locate the proposed land use.

Project Operations-Onsite Noise Sources

As previously stated, noise sensitive land uses are locations where people reside or where the presence of unwanted sound could adversely affect the use of the land. Residences, schools, hospitals, guest lodging, libraries, and some passive recreation areas would each be considered noise-sensitive and may warrant unique measures for protection from intruding noise. The nearest existing noise-sensitive land use to the Project site consists of a single-family residence located 1,342 feet from the proposed Project site boundary, to the north and across the Aqueduct.

The main stationary operational noise associated with the Project would be from the proposed transformers, inverters, substation, and transmission lines. Onsite Project operations have been calculated using the SoundPLAN 3D noise model. As previously stated, a noise level of 47.1 dBA was employed as

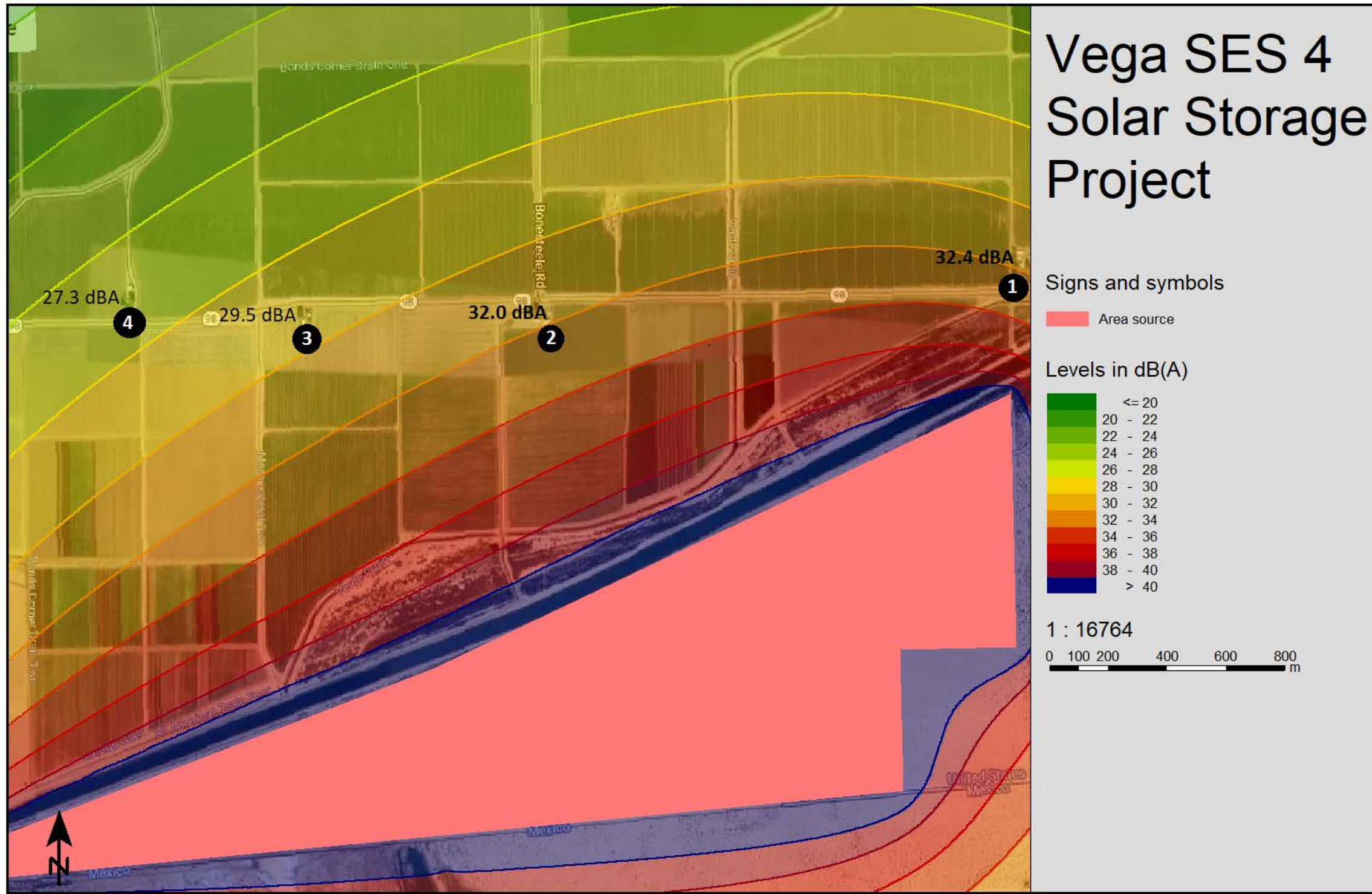
the reference noise level in the SoundPLAN 3D noise model to determine noise-level propagation associated with the Project operations. The results of this model can be found in Appendix C. Table 5-2 shows the predicted Project noise levels at the nearest noise-sensitive land use in the Project vicinity, as predicted by SoundPLAN. Also see Figure 3.

Location	Modeled Operational Noise Attributed to Project (L_{eq} dBA)	County Daytime Standard (L_{eq} dB)	County Nighttime Standard (L_{eq} dB)	Exceed Standard?
Property line of the nearest residence	32.4	50.0	45.0	No

Source: Stationary source noise levels were modeled by ECORP using SoundPLAN 3D noise model. Refer to Appendix C for noise modeling assumptions and results.

Note: Reference noise measurement used to calculate Project onsite noise propagation identified at 47.1 dBA, per 30-minute measurements taken at a VEGA SES 4 solar generation facility in Imperial County.

As shown in Table 5-2, Project operational noise would not exceed County daytime or nighttime standards.



Map Date: 1/27/2021
 Photo (or Base) Source: SoundPLAN 3D Noise Model, v. 5.1

Figure 3. Project Onsite Source Noise Generation

5.3.3 Project Construction Groundborne Vibration

Would the Project Expose Structures to Substantial Groundborne Vibration During Construction?

Excessive groundborne vibration impacts result from continuously occurring vibration levels. Increases in groundborne vibration levels attributable to the Project would be primarily associated with short-term construction-related activities. Construction on the Project site would have the potential to result in varying degrees of temporary groundborne vibration, depending on the specific construction equipment used and the operations involved. Ground vibration generated by construction equipment spreads through the ground and diminishes in magnitude with increases in distance.

Construction-related ground vibration is normally associated with impact equipment such as pile drivers, jackhammers, and the operation of some heavy-duty construction equipment, such as dozers and trucks. It is noted that pile drivers would not be necessary during Project construction. Vibration decreases rapidly with distance and it is acknowledged that construction activities would occur throughout the Project site and would not be concentrated at the point closest to sensitive receptors. Groundborne vibration levels associated with typical construction equipment at 25 feet distant are summarized in Table 5-3.

Equipment Type	Peak Particle Velocity at 25 Feet (inches per second)
Large Bulldozer	0.089
Caisson Drilling	0.089
Loaded Trucks	0.076
Hoe Ram	0.089
Jackhammer	0.035
Small Bulldozer/Tractor	0.003
Vibratory Roller	0.210

Source: FTA 2018; Caltrans 2020b

The County of Imperial does not regulate vibrations associated with construction. However, a discussion of construction vibration is included for full disclosure purposes. For comparison purposes, the Caltrans (2020b) recommended standard of 0.2 inch per second PPV with respect to the prevention of structural damage for older residential buildings is used as a threshold. This is also the level at which vibrations may begin to annoy people in buildings. Consistent with FTA recommendations for calculating construction vibration, construction vibration was measured from the center of the Project site (FTA 2018). The nearest structure of concern to the construction site, with regard to groundborne vibrations, is the Aqueduct located 100 feet from the proposed Project site boundary.

Based on the representative vibration levels presented for various construction equipment types in Table 5-3 and the construction vibration assessment methodology published by the FTA (2018), it is possible to estimate the potential project construction vibration levels. The FTA provides the following equation:

$$[PPV_{equip} = PPV_{ref} \times (25/D)^{1.5}]$$

Table 5-4 presents the expected Project related vibration levels at a distance of 100 feet.

Table 5-4. Construction Vibration Levels at 100 Feet							
Receiver PPV Levels (in/sec) ¹					Peak Vibration	Threshold	Exceed Threshold
Large Bulldozer, Caisson Drilling, & Hoe Ram	Loaded Trucks	Jackhammer	Small Bulldozer	Vibratory Roller			
0.011	0.009	0.004	0.000	0.026	0.026	0.2	No

Notes: ¹Based on the Vibration Source Levels of Construction Equipment included on Table 5-5 (FTA 2018). Distance to the nearest structure of concern is approximately 100 feet measured from project site boundary.

As shown in Table 5-4, vibration as a result of construction activities would not exceed 0.2 PPV at the nearest structure. Thus, project construction would not exceed the recommended threshold.

5.3.4 Project Operational Groundborne Vibration

Would the Project Expose Structures to Substantial Groundborne Vibration During Operations?

Project operations would not include the use of any large-scale stationary equipment that would result in excessive vibration levels. Therefore, the project would not result groundborne vibration impacts during operations.

5.3.5 Excess Airport Noise

Would the Project Expose People Residing or Working in the Project area to Excessive Airport Noise?

The Project site is located approximately 12 miles east from the Calexico International Airport in Unincorporated lands of Imperial County and 8.69 miles from Calexico city limits. The Imperial County Airport Land Use Commission has established a set of land use compatibility criteria for lands surrounding the airports in Imperial County in the Imperial County Airport Land Use Compatibility Plan (1996). As identified in Figure 3-B of the Imperial County Airport Land Use Compatibility Maps, the proposed Project site lays outside of the noise contours of the Calexico International Airport. Thus, the Project would not expose residents to excessive airport noise.

5.3.6 Cumulative Noise

Would the Project Contribute to Cumulatively Considerable Noise During Construction?

Construction activities associated with the proposed Project and other construction projects in the area may overlap, resulting in construction noise in the area. However, construction noise impacts primarily affect the areas adjacent to the construction site. Construction noise for the proposed Project was determined to be less than significant following compliance with County noise standards. Cumulative development in the vicinity of the Project site could result in elevated construction noise levels at sensitive receptors in the Project area. However, each project would be required to comply with the applicable noise limitations on construction. Therefore, the Project would not contribute to cumulative impacts during construction.

Would the Project Contribute to Cumulatively Considerable Noise from Offsite Traffic?

As described previously, Project operations would result in extremely minimal additional traffic on adjacent roadways. The only visitors to the site would be that of repair or maintenance work that would be done very infrequently. Thus, any cumulative noise impacts from project-related traffic would be minimal. Therefore, the Project's contribution to cumulative noise impacts from traffic would be less than significant.

Would the Project Contribute to Cumulatively Considerable Noise from Stationary Sources?

Cumulative noise impacts would primarily be associated with the transformers, inverters, substation, and transmission lines from the solar facility. Long-term noise sources associated with development at the Project, combined with other cumulative projects, could cause local noise-level increases. Noise levels associated with the proposed Project and related cumulative projects together could result in higher noise levels than considered separately. However, noise increase as a result of the Project would not be perceivable and would not exceed County standards.

6.0 REFERENCES

- Caltrans. 2020a. IS/EA Annotated Outline. <http://www.dot.ca.gov/ser/vol1/sec4/ch31ea/chap31ea.htm>.
- _____. 2020b. Transportation and Construction Vibration Guidance Manual.
- _____. 2018. Traffic Census Program: 2017 Traffic Volumes. <https://dot.ca.gov/programs/traffic-operations/census>
- _____. 2013. Technical Noise Supplement to the Traffic Noise Analysis Protocol.
- FHWA. 2011. Effective Noise Control During Nighttime Construction. Available online at: http://ops.fhwa.dot.gov/wz/workshops/accessible/schexnayder_paper.htm.
- _____. 2006. Roadway Construction Noise Model.
- FTA. 2018. Transit Noise and Vibration Impact Assessment.
- HMMH. 2006. Transit Noise and Vibration Impact Assessment, Final Report.
- Imperial, County of. 2015. General Plan Noise Element.
- _____. 2008. General Plan Circulation and Scenic Highways Element.
- _____. 1996. Imperial County Airport Land Use Compatibility Plan.
- KOA Corporation. 2020. Scoping Memorandum for the Traffic Impact Study.
- OPR. 2003. State of California General Plan Guidelines.
- WEAL. 2000. Sound Transmission Sound Test Laboratory Report No. TL 96-186.

LIST OF ATTACHMENTS

Attachment A - Baseline (Existing) Noise Measurements – Project Site and Vicinity

Attachment B - Federal Highway Administration Highway Roadway Construction Noise Outputs
– Project Construction Noise

Attachment C - SoundPLAN 3-D Noise Model Outputs – Project Onsite Noise

Baseline (Existing) Noise Measurements – Project Site and Vicinity



Map Date: 12/14/2020
Photo (or Base) Source: Google Earth Pro

Site Number: V4-1			
Recorded By: Jessie Beckman			
Job Number: 2020 - 142			
Date: 1/12/21			
Time: 14:30 – 14:45			
Location: CA-98, East of Bonds Corner Rd			
Source of Peak Noise: Vehicular traffic on CA-98			
Noise Data			
Leq (dB)	Lmin (dB)	Lmax (dB)	Peak (dB)
65.4	36.3	79.8	104.3

Equipment						
Category	Type	Vendor	Model	Serial No.	Cert. Date	Note
Sound	Sound Level Meter	Larson Davis	LxT SE	0005120	9/14/2020	
	Microphone	Larson Davis	377B02	174464	9/14/2020	
	Preamp	Larson Davis	PRMLxT1L	042852	9/14/2020	
	Calibrator	Larson Davis	CAL200	14105	9/10/2020	
Weather Data						
Est.	Duration: 15 minutes			Sky: 50%cc		
	Note: Cal Offset = 0.26			Sensor Height (ft): 3.5		
	Wind Ave Speed (mph)		Temperature (degrees Fahrenheit)		Barometer Pressure (hPa)	
	0-2		70		30.25Hg	

Photo of Measurement Location



PC ORIGINAL PKG

Measurement Report

Report Summary

Meter's File Name	LxT_Data.356	Computer's File Name	SLM_0005120_LxT_Data_356.00.ldbin
Meter	LxT SE		
Firmware	2.404		
User	Lindsay Liegler	Location	
Description			
Note			
Start Time	2021-01-12 13:51:20	Duration	0:15:00.0
End Time	2021-01-12 14:06:20	Run Time	0:15:00.0
		Pause Time	0:00:00.0

Results

Overall Metrics

LA _{eq}	65.4 dB		
LAE	95.0 dB	SEA	--- dB
EA	349.6 µPa²h		
LZ _{peak}	104.3 dB	2021-01-12 13:55:26	
LAS _{max}	79.8 dB	2021-01-12 13:55:26	
LAS _{min}	36.3 dB	2021-01-12 13:58:17	
LA _{eq}	65.4 dB		
LC _{eq}	72.8 dB	LC _{eq} - LA _{eq}	7.4 dB
LAI _{eq}	68.4 dB	LAI _{eq} - LA _{eq}	3.0 dB

Exceedances

	Count	Duration
LAS > 85.0 dB	0	0:00:00.0
LAS > 115.0 dB	0	0:00:00.0
LZ _{peak} > 135.0 dB	0	0:00:00.0
LZ _{peak} > 137.0 dB	0	0:00:00.0
LZ _{peak} > 140.0 dB	0	0:00:00.0

Community Noise

LDN	LDay	LNight	
65.4 dB	65.4 dB	0.0 dB	
LDEN	LDay	LEve	LNight
65.4 dB	65.4 dB	--- dB	--- dB

Any Data

	A		C		Z	
	Level	Time Stamp	Level	Time Stamp	Level	Time Stamp
L _{eq}	65.4 dB		72.8 dB		--- dB	
LS _(max)	79.8 dB	2021-01-12 13:55:26	--- dB		--- dB	
LS _(min)	36.3 dB	2021-01-12 13:58:17	--- dB		--- dB	
L _{Peak(max)}	--- dB		--- dB		104.3 dB	2021-01-12 13:55:26

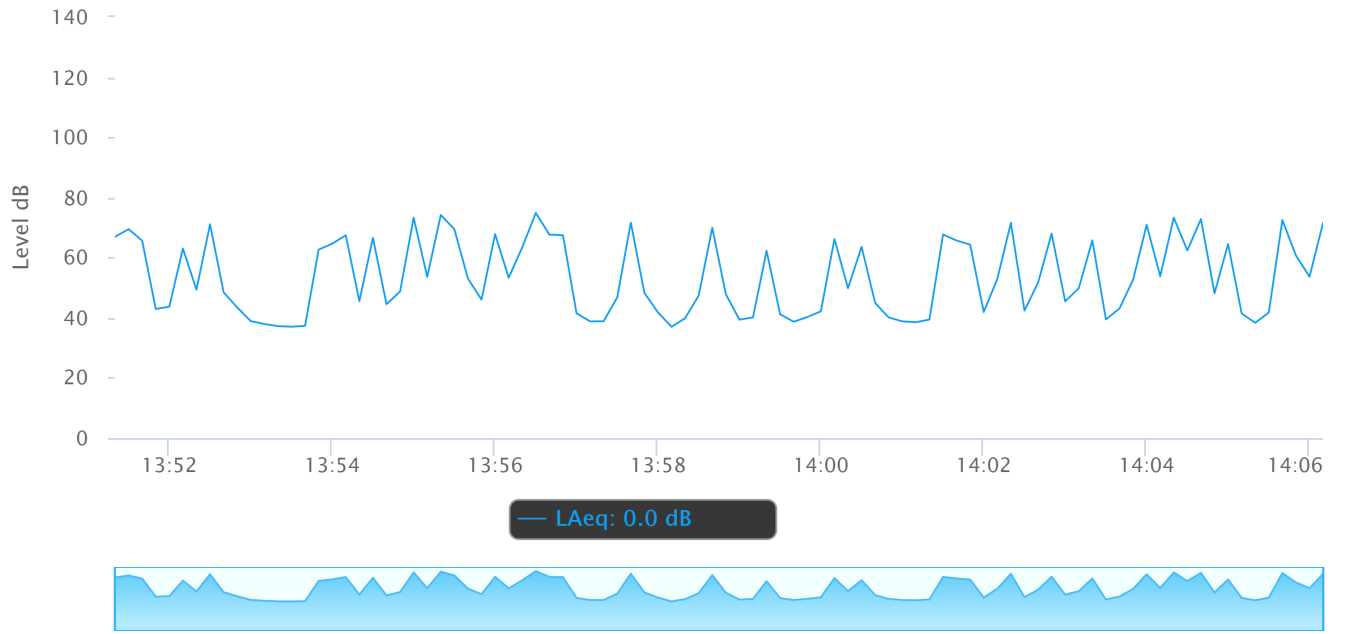
Overloads

Count	Duration	OBA Count	OBA Duration
0	0:00:00.0	20	0:01:04.10

Statistics

LAS 5.0	73.3 dB
LAS 10.0	70.1 dB
LAS 33.3	55.2 dB
LAS 50.0	48.2 dB
LAS 66.6	43.3 dB
LAS 90.0	38.6 dB

Time History



Site Number: V4-2			
Recorded By: Jessie Beckman			
Job Number: 2020 - 142			
Date: 1/12/21			
Time: 14:10 – 14:25			
Location: CA-98, East of Bonesteel Rd			
Source of Peak Noise: Vehicular traffic on CA-98			
Noise Data			
Leq (dB)	Lmin (dB)	Lmax (dB)	Peak (dB)
68.7	25.2	86.2	106.8

Equipment						
Category	Type	Vendor	Model	Serial No.	Cert. Date	Note
Sound	Sound Level Meter	Larson Davis	LxT SE	0005120	9/14/2020	
	Microphone	Larson Davis	377B02	174464	9/14/2020	
	Preamp	Larson Davis	PRMLxT1L	042852	9/14/2020	
	Calibrator	Larson Davis	CAL200	14105	9/10/2020	
Weather Data						
Est.	Duration: 15 minutes			Sky: 50%cc		
	Note: Cal Offset = 0.26			Sensor Height (ft): 3.5		
	Wind Ave Speed (mph)		Temperature (degrees Fahrenheit)		Barometer Pressure (hPa)	
	0-2		70		30.25Hg	

Photo of Measurement Location



Measurement Report

Report Summary

Meter's File Name	LxT_Data.357	Computer's File Name	SLM_0005120_LxT_Data_357.00.ldbin
Meter	LxT SE		
Firmware	2.404		
User	Lindsay Liegler	Location	
Description			
Note			
Start Time	2021-01-12 14:10:16	Duration	0:15:00.0
End Time	2021-01-12 14:25:16	Run Time	0:15:00.0
		Pause Time	0:00:00.0

Results

Overall Metrics

LA _{eq}	68.7 dB		
LAE	98.2 dB	SEA	--- dB
EA	742.4 μPa²h		
LZ _{peak}	106.8 dB	2021-01-12 14:23:46	
LAS _{max}	86.2 dB	2021-01-12 14:23:46	
LAS _{min}	25.2 dB	2021-01-12 14:21:16	
LA _{eq}	68.7 dB		
LC _{eq}	75.5 dB	LC _{eq} - LA _{eq}	6.8 dB
LAI _{eq}	72.4 dB	LAI _{eq} - LA _{eq}	3.7 dB

Exceedances

	Count	Duration
LAS > 85.0 dB	1	0:00:01.5
LAS > 115.0 dB	0	0:00:00.0
LZ _{peak} > 135.0 dB	0	0:00:00.0
LZ _{peak} > 137.0 dB	0	0:00:00.0
LZ _{peak} > 140.0 dB	0	0:00:00.0

Community Noise

LDN	LDay	LNight	
68.7 dB	68.7 dB	0.0 dB	
LDEN	LDay	LEve	LNight
68.7 dB	68.7 dB	--- dB	--- dB

Any Data

	A		C		Z	
	Level	Time Stamp	Level	Time Stamp	Level	Time Stamp
L _{eq}	68.7 dB		75.5 dB		--- dB	
LS _(max)	86.2 dB	2021-01-12 14:23:46	--- dB		--- dB	
LS _(min)	25.2 dB	2021-01-12 14:21:16	--- dB		--- dB	
L _{Peak(max)}	--- dB		--- dB		106.8 dB	2021-01-12 14:23:46

Overloads

Count	Duration	OBA Count	OBA Duration
0	0:00:00.0	32	0:01:38.2

Statistics

LAS 5.0	76.8 dB
LAS 10.0	72.9 dB
LAS 33.3	53.2 dB
LAS 50.0	46.9 dB
LAS 66.6	42.5 dB
LAS 90.0	35.9 dB

Site Number: V4 - 3			
Recorded By: Jessie Beckman			
Job Number: 2020 - 142			
Date: 1/12/2021			
Time: 13:51 – 14:06			
Location: CA-98, Southeastern Extent			
Source of Peak Noise: Vehicular Traffic on CA-98			
Noise Data			
Leq (dB)	Lmin (dB)	Lmax (dB)	Peak (dB)
66.1	40.8	81.5	103.8

Equipment						
Category	Type	Vendor	Model	Serial No.	Cert. Date	Note
Sound	Sound Level Meter	Larson Davis	LxT SE	0005120	9/14/2020	
	Microphone	Larson Davis	377B02	174464	9/14/2020	
	Preamp	Larson Davis	PRMLxT1L	042852	9/14/2020	
	Calibrator	Larson Davis	CAL200	14105	9/10/2020	
Weather Data						
Est.	Duration: 15 minutes			Sky: 40% cc		
	Note: dBA Offset = 0.01 Cal Offset = 0.26			Sensor Height (ft): 3.5		
	Wind Ave Speed (mph)		Temperature (degrees Fahrenheit)		Barometer Pressure (hPa)	
	0-2		70		30.25 Hg	

Photo of Measurement Location



Measurement Report

Report Summary

Meter's File Name	LxT_Data.358	Computer's File Name	SLM_0005120_LxT_Data_358.00.ldbin
Meter	LxT SE		
Firmware	2.404		
User	Lindsay Liegler	Location	
Description			
Note			
Start Time	2021-01-12 14:29:25	Duration	0:15:00.0
End Time	2021-01-12 14:44:25	Run Time	0:15:00.0
		Pause Time	0:00:00.0

Results

Overall Metrics

LA _{eq}	66.1 dB		
LAE	95.7 dB	SEA	--- dB
EA	411.7 µPa²h		
LZ _{peak}	103.8 dB	2021-01-12 14:31:03	
LAS _{max}	81.5 dB	2021-01-12 14:29:25	
LAS _{min}	40.8 dB	2021-01-12 14:43:50	
LA _{eq}	66.1 dB		
LC _{eq}	73.5 dB	LC _{eq} - LA _{eq}	7.4 dB
LAI _{eq}	69.5 dB	LAI _{eq} - LA _{eq}	3.3 dB

Exceedances

	Count	Duration
LAS > 85.0 dB	0	0:00:00.0
LAS > 115.0 dB	0	0:00:00.0
LZ _{peak} > 135.0 dB	0	0:00:00.0
LZ _{peak} > 137.0 dB	0	0:00:00.0
LZ _{peak} > 140.0 dB	0	0:00:00.0

Community Noise

LDN	LDay	LNight	
66.1 dB	66.1 dB	0.0 dB	
LDEN	LDay	LEve	LNight
66.1 dB	66.1 dB	--- dB	--- dB

Any Data

	A		C		Z	
	Level	Time Stamp	Level	Time Stamp	Level	Time Stamp
L _{eq}	66.1 dB		73.5 dB		--- dB	
LS _(max)	81.5 dB	2021-01-12 14:29:25	--- dB		--- dB	
LS _(min)	40.8 dB	2021-01-12 14:43:50	--- dB		--- dB	
L _{Peak(max)}	--- dB		--- dB		103.8 dB	2021-01-12 14:31:03

Overloads

Count	Duration	OBA Count	OBA Duration
0	0:00:00.0	23	0:01:11.1

Statistics

LAS 5.0	74.0 dB
LAS 10.0	70.9 dB
LAS 33.3	56.4 dB
LAS 50.0	50.4 dB
LAS 66.6	46.6 dB
LAS 90.0	42.5 dB

Federal Highway Administration Highway Roadway Construction Noise Outputs – Project
Construction Noise

Roadway Construction Noise Model (RCNM),Version 1.1

Report date: 1/25/2021
 Case Description: Site Prep

Description Affected Land Use
 Site Prep Residential

Description	Impact Device	Usage(%)	Equipment		Receptor Distance (feet)
			Spec Lmax (dBA)	Actual Lmax (dBA)	
Rubber Tired Loader	No	40		79.1	1342
Rubber Tired Loader	No	40		79.1	1342
Tractor	No	40	84		1342
Tractor	No	40	84		1342

Calculated (dBA)

Equipment	*Lmax	Leq
Rubber Tired Loader	50.5	46.6
Rubber Tired Loader	50.5	46.6
Tractor	55.4	51.4
Tractor	55.4	51.4
Total	55.4	55.7

*Calculated Lmax is the Loudest value.

Roadway Construction Noise Model (RCNM),Version 1.1

Report date: 1/25/2021
 Case Description: Grading

Description Affected Land Use
 Grading Residential

Description	Impact Device	Usage(%)	Equipment		Receptor Distance (feet)
			Spec Lmax (dBA)	Actual Lmax (dBA)	
Excavator	No	40		80.7	1342
Excavator	No	40		80.7	1342
Excavator	No	40		80.7	1342
Excavator	No	40		80.7	1342
Grader	No	40	85		1342
Grader	No	40	85		1342
Grader	No	40	85		1342
Rubber Tired Dozer	No	40		81.7	1342
Rubber Tired Dozer	No	40		81.7	1342
Scraper	No	40		83.6	1342
Scraper	No	40		83.6	1342
Tractor/Loader/Backhoe	No	40	84		1342
Tractor/Loader/Backhoe	No	40	84		1342
Tractor/Loader/Backhoe	No	40	84		1342
Tractor/Loader/Backhoe	No	40	84		1342

Calculated (dBA)

Equipment	*Lmax	Leq
Excavator	52.1	48.2
Excavator	52.1	48.2
Excavator	52.1	48.2
Excavator	52.1	48.2
Grader	56.4	52.4
Grader	56.4	52.4
Grader	56.4	52.4
Rubber Tired Dozer	53.1	49.1
Rubber Tired Dozer	53.1	49.1
Scraper	55	51
Scraper	55	51
Tractor/Loader/Backhoe	55.4	51.4
Tractor/Loader/Backhoe	55.4	51.4
Tractor/Loader/Backhoe	55.4	51.4
Tractor/Loader/Backhoe	55.4	51.4
Total	56.4	62.5

*Calculated Lmax is the Loudest value.

Roadway Construction Noise Model (RCNM),Version 1.1

Report date: 1/25/2021
 Case Description: Construction

Description Affected Land Use
 Construction Residential

Description	Impact Device	Usage(%)	Equipment		Receptor Distance (feet)
			Spec Lmax (dBA)	Actual Lmax (dBA)	
Crane	No	16		80.6	1342
Paver	No	50		77.2	1342
Paveing Equipment	No	20		89.5	1342
Paveing Equipment	No	20		89.5	1342
Pile Driver	Yes	20		101.3	1342
Pile Driver	Yes	20		101.3	1342
Pile Driver	Yes	20		101.3	1342
Pile Driver	Yes	20		101.3	1342
Roller	No	20		80	1342
Roller	No	20		80	1342
Rough Terrain Forklift	No	40		83.4	1342
Rough Terrain Forklift	No	40		83.4	1342
Rough Terrain Forklift	No	40		83.4	1342
Rough Terrain Forklift	No	40		83.4	1342
Tractor/Loader/Backhoe	No	40	84		1342
Tractor/Loader/Backhoe	No	40	84		1342
Tractor/Loader/Backhoe	No	40	84		1342
Tractor/Loader/Backhoe	No	40	84		1342
Trencher	No	50		80.4	1342

Calculated (dBA)

Equipment	*Lmax	Leq
Crane	52	44
Paver	48.6	45.6
Paveing Equipment	60.9	53.9
Paveing Equipment	60.9	53.9
Pile Driver	72.7	65.7
Pile Driver	72.7	65.7
Pile Driver	72.7	65.7
Pile Driver	72.7	65.7
Roller	51.4	44.4
Roller	51.4	44.4
Rough Terrain Forklift	54.8	50.8
Rough Terrain Forklift	54.8	50.8
Rough Terrain Forklift	54.8	50.8
Rough Terrain Forklift	54.8	50.8
Tractor/Loader/Backhoe	55.4	51.4
Tractor/Loader/Backhoe	55.4	51.4
Tractor/Loader/Backhoe	55.4	51.4
Tractor/Loader/Backhoe	55.4	51.4
Trencher	51.8	48.8
Total	72.7	72.2

*Calculated Lmax is the Loudest value.

SoundPLAN 3-D Noise Model Outputs – Project Onsite Noise

SoundPLAN
Output Source Information

Number	Receiver Name	Floor	Level at Receiver
1	Residence to the north	Ground Floor	32.4 dBA
2	Residence to the north	Ground Floor	32.0 dBA
3	Residence to the north	Ground Floor	29.5 dBA
4	Residence to the north	Ground Floor	27.3 dBA

Number	Noise Source Information	Citation	Level at Source
1	Noise Activity at Solar Facility	ECORP Consulting	47.1 dBA

Vega SES 4 Solar Energy Storage Project

TRAFFIC IMPACT STUDY
IMPERIAL COUNTY, CALIFORNIA

Prepared By:



December, 2021

Table of Contents

1.0 INTRODUCTION	5
PROJECT LOCATION	5
PROJECT DESCRIPTION	6
CONSTRUCTION ACTIVITIES.....	7
2.0 CAPACITY ANALYSIS METHODOLOGIES.....	7
STUDY AREA CRITERIA.....	7
SCENARIO CRITERIA	8
PEAK HOUR INTERSECTION LEVEL OF SERVICE STANDARDS.....	8
ROADWAY SEGMENT LEVEL OF SERVICE STANDARDS.....	9
FREEWAY SEGMENTS	9
ANALYSIS OF SIGNIFICANCE.....	10
3.0 EXISTING CONDITIONS	11
EXISTING ROADWAYS.....	11
TRAFFIC VOLUMES	13
EXISTING YEAR CONDITIONS	14
FREEWAY SEGMENT ANALYSIS	15
4.0 TRIP GENERATION/DISTRIBUTION/ASSIGNMENT	15
PROJECT TRIP GENERATION.....	15
TRIP DISTRIBUTION ASSIGNMENT.....	16
5.0 CONSTRUCTION YEAR CONDITIONS	17
SEGMENTS.....	20
INTERSECTIONS.....	20
FREEWAY SEGMENT ANALYSIS	21
6.0 CIRCULATION	22
PROJECT ACCESS AND CIRCULATION	22
PARKING.....	23
7.0 VEHICLE MILES TRAVELLED.....	23
8.0 IMPACTS AND MITIGATIONS	24

List of Figures

FIGURE 1.1: STUDY AREA	5
FIGURE 1.2: SITE PLAN	6
FIGURE 3.1: INTERSECTION GEOMETRICS	12
FIGURE 3.2: EXISTING VOLUMES	13
FIGURE 4.1: TRIP DISTRIBUTION	16
FIGURE 5.1: CONSTRUCTION YEAR VOLUMES.....	18
FIGURE 5.2: CONSTRUCTION YEAR PLUS PROJECT YEAR VOLUMES	19

List of Tables

TABLE 2.1: HCM LEVEL OF SERVICE DEFINITIONS FOR INTERSECTIONS	8
TABLE 2.2: COUNTY OF IMPERIAL ADT LEVEL OF SERVICE VOLUMES BY ROADWAY TYPE.....	9
TABLE 2.3: CALTRANS FREEWAY SEGMENT LEVEL OF SERVICE DEFINITIONS.....	10
TABLE 3.1: EXISTING YEAR CONDITIONS ROADWAY SEGMENT ANALYSIS	14
TABLE 3.2: EXISTING YEAR CONDITIONS PEAK HOUR INTERSECTION ANALYSIS	14
TABLE 3.3: EXISTING FREEWAY LEVEL OF SERVICE	15
TABLE 4.1: CONSTRUCTION TRIP GENERATION - CONSTRUCTION PHASE.....	15
TABLE 5.1: CONSTRUCTION YEAR ROADWAY SEGMENT ANALYSIS.....	20
TABLE 5.2: CONSTRUCTION YEAR PEAK HOUR INTERSECTION ANALYSIS.....	21
TABLE 5.3: CONSTRUCTION YEAR FREEWAY LEVEL OF SERVICE.....	21

APPENDICES

APPENDIX A: TRAFFIC COUNT DATA..... 25
APPENDIX B: EXISTING YEAR CONDITIONS ANALYSIS WORKSHEETS 46
APPENDIX C: NEAR TERM ANALYSIS WORKSHEETS..... 63
APPENDIX D: NEAR TERM WITH PROJECT ANALYSIS WORKSHEETS 80

1.0 Introduction

This traffic impact analysis (TIA) has been prepared to identify the potential traffic impacts associated with developing the Vega SES 4 Solar Energy Storage (Projects) in Imperial County. The study was completed following the guidelines described in the County of Imperial Department of Public Works *Traffic Study and Report Policy* dated March 12, 2007, revised June 29, 2007 and approved by the Board of Supervisors of the County of Imperial on August 7, 2007 ("Traffic Study and Report Policy").

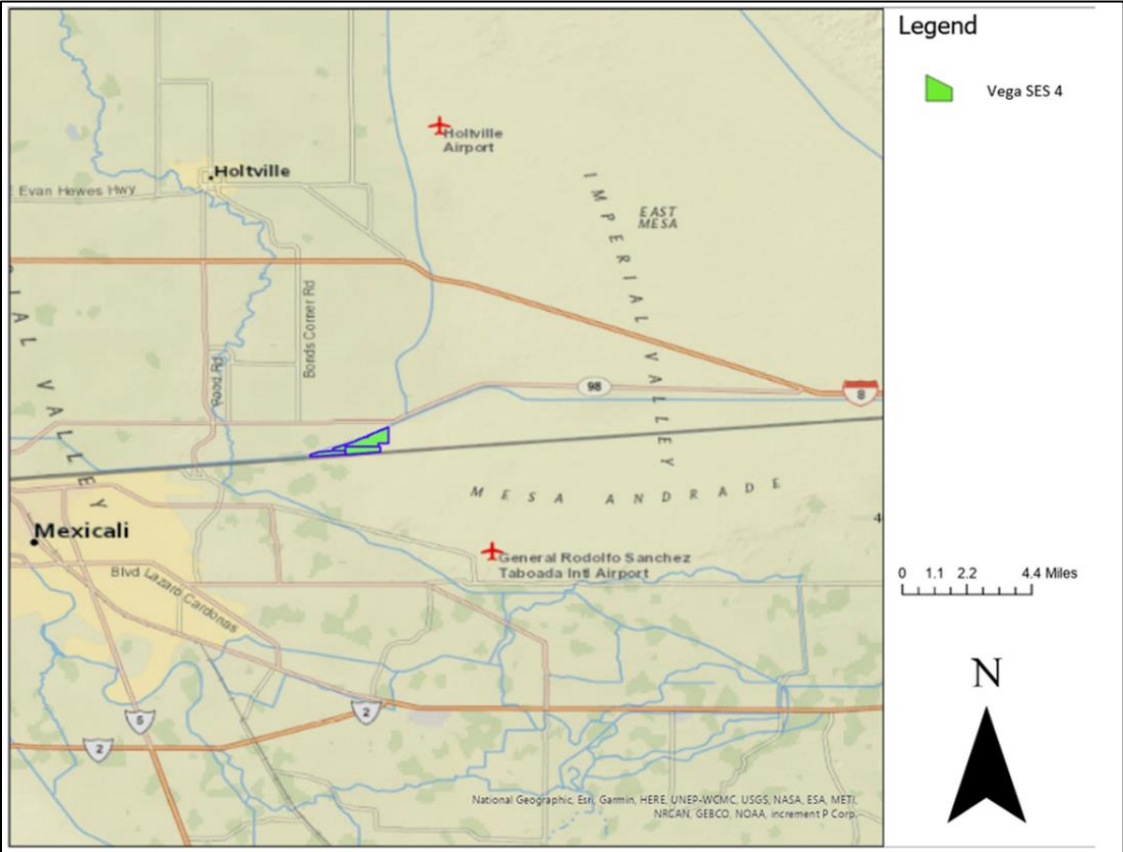
KOA has coordinated with the County's Engineering Department on the scope of the traffic analysis, including the study area and future year analysis assumptions. As necessary, if required, projects will be identified to offset or reduce significant impacts. Based on discussions with City staff, current and future traffic conditions at select intersections in close proximity to the proposed project have been evaluated for the purposes of this TIA.

This report describes the existing roadway network in the vicinity of the project site. It includes a review of the existing and proposed traffic activities for weekday peak AM and PM periods and daily traffic conditions.

Project Location

The project location is shown in Figure 1.1.

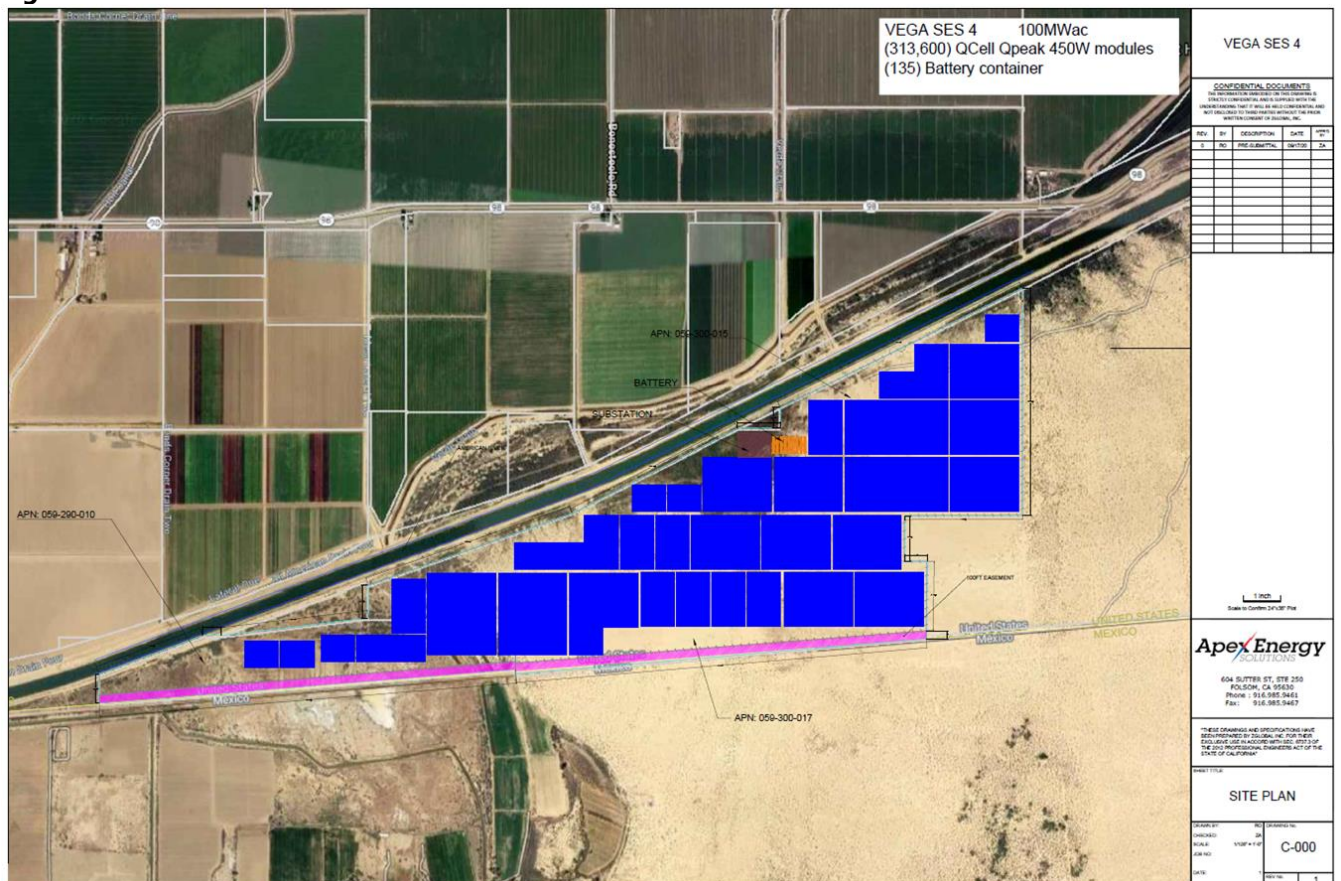
Figure 1.1 Study Area



Project Description

Vega SES 4 LLC. is proposing to develop the Vega SES 4 Solar Energy Storage Project (Projects). The project is a 100-megawatt alternating current (MWAC) solar photovoltaic (PV) energy generation project with an integrated 100 MW battery storage project on approximately 531.53 acres of land in the County of Imperial, California. The Project would be located between the California/Mexico border and the All-American Canal, on the California side. It is approximately 10 miles east of Calexico. The construction of the site is estimated to take 12-18 months and would begin in 2022. The project opening is anticipated to be 2023. The project site plan is shown in Figure 1.2.

Figure 1.2 Site Plan



Construction Activities

The construction of the site to include site preparation and construction is estimated to take 12-18 months and would begin in 2022. The number of on-site construction workers for the solar project facilities is not expected to exceed 150 workers at any one time. The number of on-site construction workers for the battery storage facility and the substation is not expected to exceed 100 workers at any one time.

Construction of the Projects will include the following activities:

- Site preparation
- Grading and earthwork
- Concrete foundations
- Structural steel work
- Electrical/instrumentation work
- Collector line installation
- Architecture and landscaping

2.0 Capacity Analysis Methodologies

This section presents a brief overview of traffic analysis methodologies and concepts used in this study. Street system operating conditions are typically described in terms of "level of service (LOS)" to compare without project and with project alternatives. LOS is a report-card scale used to indicate the quality of traffic flow on roadway segments and at intersections. The levels of service range from Level A (free flow, little congestion) to Level F (forced flow, higher congestion).

Study Area Criteria

The study area is determined based on the County of Imperial Department of Public Works *Traffic Study and Report Policy* dated March 12, 2007, revised June 29, 2007 and approved by the Board of Supervisors of the County of Imperial on August 7, 2007 ("Traffic Study and Report Policy"). "Any project that has the potential to degrade an existing road section, an existing signalized intersection, or an existing unsignalized intersection to below the existing level of service or to cause it to be lower than a level of service (LOS) "C" during any peak hour, using the HCM Methods of analysis on any individual, existing traffic movement." Traffic Study and Report Policy, 4-5.

The study area for this project includes those locations that likely will be affected by this project. The project study area was determined based on similar solar projects. The specific study area consists of the following intersections:

1. Site driveway and SR-98
2. Bonds Corner Road and SR-98
3. SR-98 and SR-7
4. SR-7 and Heber Road
5. SR-7 and south ramp
6. SR-7 and north ramp

The study area also includes the following study segments:

1. SR-98 from the project to the east
2. SR-98 from the project to Bonds Corner Road
3. SR-98 from Bonds Corner Road to SR-7
4. SR-7 from SR-98 to I-8
5. I-8 from SR-7 to SR-111

Scenario Criteria

The proposed project's traffic impacts were analyzed in three scenarios as listed below. The traffic analysis included intersections and roadway segments within Imperial County and Caltrans District 11 in the following scenarios to determine the potential impacts.

- Existing Year (2020) Conditions
- Construction Year (2023) Baseline Conditions
- Construction Year (2023) + Project Construction Conditions

Peak Hour Intersection Level of Service Standards

Traffic conditions on most roadway facilities are analyzed using the principles of the specific analysis methods contained in the latest version (2010) of the *Highway Capacity Manual (HCM)*, a publication of the Transportation Research Board, a research agency affiliated with the Federal Government. Chapter 18 of the *HCM 2010* is devoted to analysis of signalized intersections. The methodology in the *HCM 2010* for signalized intersections is based upon measurements or forecasts of control delay for traffic utilizing all approaches to the intersection.

Unsignalized intersections, including two-way and all-way stop controlled intersections were analyzed using the 2010 Highway Capacity Manual unsignalized intersection analysis methodology. The LOS for a two-way stop controlled (TWSC) intersection is determined by the computed or measured control delay and is defined for each minor movement. The analysis of peak hour intersection conditions was conducted using the Synchro 10 software program developed by Trafficware. Results are displayed in terms of control delay (seconds per vehicle) and an equivalent LOS as shown in Table 2.1.

Table 2.1: HCM Level of Service Definitions for Intersections

LOS	Signalized Intersection Delay (Seconds per Vehicle)	Unsignalized Intersection Average Stop Delay (Seconds)
A	<10	<10
B	>10 and <20	>10 and <15
C	>20 and <35	>15 and <25
D	>35 and <55	>25 and <35
E	>55 and <80	>35 and <50
F	>80	>50

Source: Highway Capacity Manual, 2010.

Roadway Segment Level of Service Standards

Roadway segment LOS standards and thresholds provide the basis for analysis of roadway segment performance. The analysis of roadway segment LOS is based on the functional classification of the roadway, the maximum capacity, roadway geometrics, and existing or forecast Average Daily Traffic (ADT) volumes.

The County of Imperial level of service analysis was performed by utilizing the *Circulation and Scenic Highways Element, January 2008*. The thresholds for each facility type are presented in Table 2.2.

Table 2.2 County of Imperial ADT Level of Service Volumes by Roadway Type

Road		Level of Service (LOS)				
Class	X-Section	A	B	C	D	E
Expressway	154/210	30,000	42,000	60,000	70,000	80,000
Prime Arterial	106/136	22,200	37,000	44,600	50,000	57,000
Minor Arterial	82/102	14,800	24,700	29,600	33,400	37,000
Major Collector	64/84	13,700	22,800	27,400	30,800	34,200
Minor (Local) Collector	40/70	1,900	4,100	7,100	10,900	16,200
<p>* Levels of service are not applied to residential streets since their primary purpose is to serve abutting lots, not carry through traffic. Levels of service normally apply to roads carrying through traffic between major trip generators and attractors.</p> <p>Source: <i>Imperial County Circulation and Scenic Highways Element 2008 and Imperial County Long Range Transportation Plan 2013 Update</i></p>						

Freeway Segments

Freeway level of service analysis is based upon procedures developed by Caltrans. The procedure for calculating freeway level of service involves calculating a peak hour volume to capacity (V/C) ratio. Peak hour volumes are calculated from Average Daily Traffic (ADT) volumes by applying design hour ("K"), directional ("D") and truck ("T") factors. The base capacities for Interstate 8 freeway lanes determined from the Highway Capacity Manual as assumed to be 2,350 passenger-car per hour per main lane (pc/h/ln).

The resulting V/C ratio is then compared to acceptable ranges of V/C values corresponding to the various levels of service for each facility classification, as shown in Table 2.3. The corresponding level of service represents an approximation of freeway operating conditions in the peak direction of travel during the peak hour. Constant with Caltrans requirements, LOS D or better is used in this study as the threshold for acceptable freeway operations.

Table 2.3 CALTRANS Level of Service Facility Classification

CALTRANS FREEWAY SEGMENT LEVEL OF SERVICE DEFINITIONS			
LOS	Maximum V/C	Congestion/Delay	Traffic Description
A	≤ 0.30	None	Free flow.
B	> 0.30 - 0.50	None	Free to stable flow, light to moderate volumes.
C	> 0.50 - 0.71	None to minimal	Stable flow, moderate volumes, freedom to maneuver noticeably restricted.
D	> 0.71 - 0.89	Minimal to substantial	Approaches unstable flow, heavy volumes, very limited freedom to maneuver.
E	> 0.89 - 1.00	Significant	Extremely unstable flow, maneuverability and psychological comfort extremely poor.
F	> 1.00	Considerable	Forced or breakdown flow. Delay measured in average travel speed (MPH). Signalized segments experience delays >60.0 seconds/vehicle.

Source: Caltrans Guide for the Preparation of Traffic Impact Studies, 2002.

Analysis of Significance

Imperial County

The significance criteria for traffic impacts are based on the Imperial County Planning & Development Services Department LOS standard as outlined in the "Circulation Element". The County's goal for an acceptable traffic service standard on an Average Daily Traffic (ADT) basis and during AM and PM peak periods for all County-Maintained Roads shall be LOS C for all street segment links and intersections.

- Strive to maintain LOS "C" or better on arterial and collector streets, at all intersections, and on principal arterials during the hour of highest volume during the AM hours and also during the PM hours. Imperial County has established LOS "C" as the general threshold for acceptable overall traffic operations for both signalized and un-signalized intersections.
- Accept LOS "D" after finding that there is no practical and feasible way to mitigate to LOS "C;" and the development causing the lower level of service provides a clear, overall public benefit.
- For segments that operate at LOS D or lower, an incremental increase in v/c of greater than 0.02 is considered to be a significant impact. For intersections that operate at LOS D or lower, an incremental increase in vehicle delay of 2.0 seconds or greater is considered to be a significant impact.

Caltrans

- For segments that operate at LOS D or lower, an incremental increase in v/c of greater than 0.02 is considered to be a significant impact. For intersections that operate at LOS D or lower, an incremental increase in vehicle delay of 2.0 seconds or greater is considered to be a significant impact.
- For freeway segments that operate at LOS D or lower, an incremental increase in v/c of greater than 0.01 is considered to be a significant impact.

3.0 Existing Conditions

This section documents the Existing Year Conditions in the study area. The Existing Year is taken to be 2020 for analysis purposes based on existing traffic counts taken in December, 2020. The discussion presented here is limited to segments and intersections in the project's vicinity.

Existing Roadways

Each of the key roadways, as well as associated study intersections within the study area, are discussed below.

Roadway Facilities

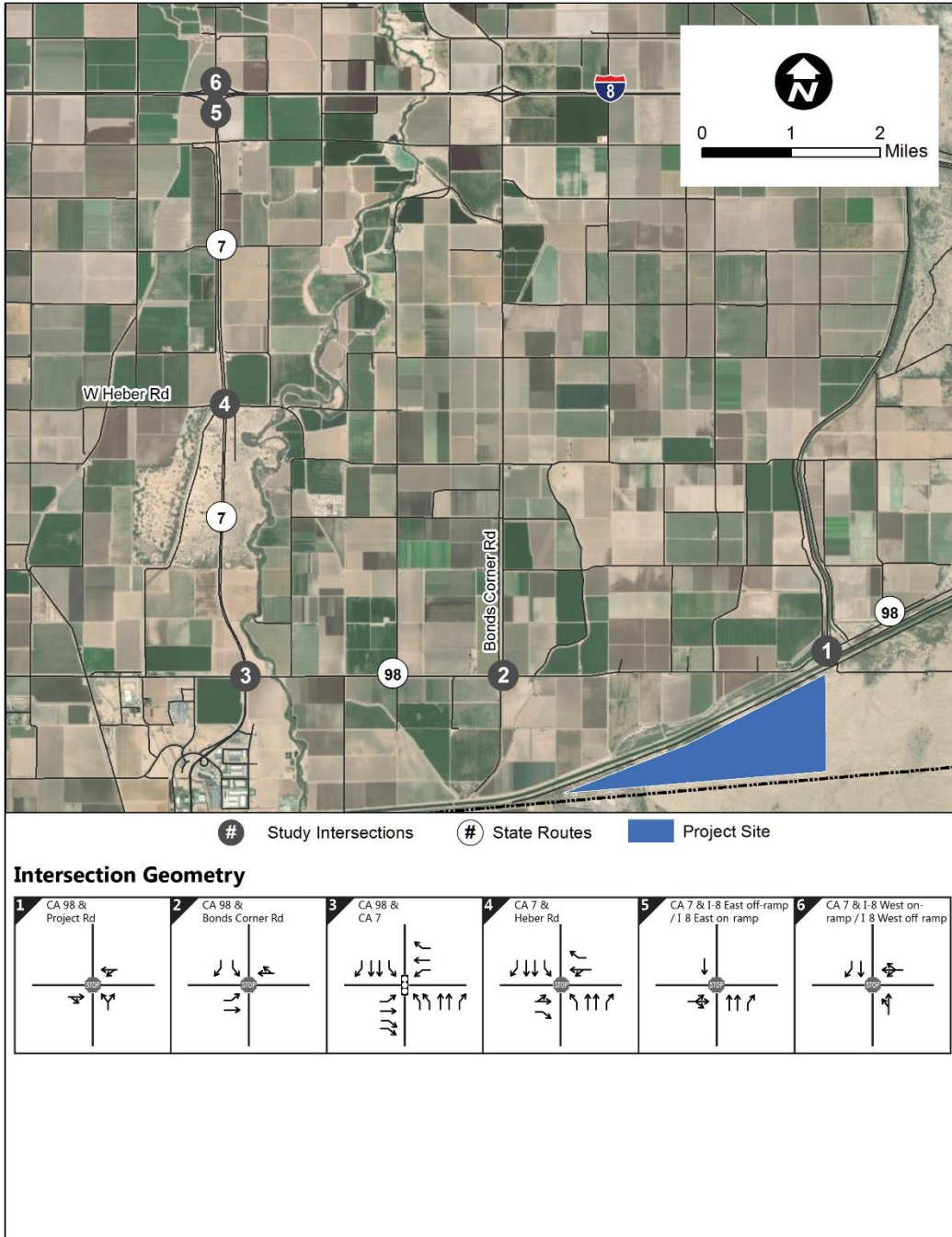
State Route 98 (SR-98) is a two-lane highway with no median and a posted speed limit of 65 mph.

State Route 7 (SR-7) is a four-lane highway with median and a posted speed limit of 65 mph between SR-98 and I-8.

Interstate 8 (I-8) is a four-lane divided freeway with two (2) lanes in each direction with a posted speed limit of 70 mph.

Figure 3.1 displays the existing intersection geometrics for study area intersections.

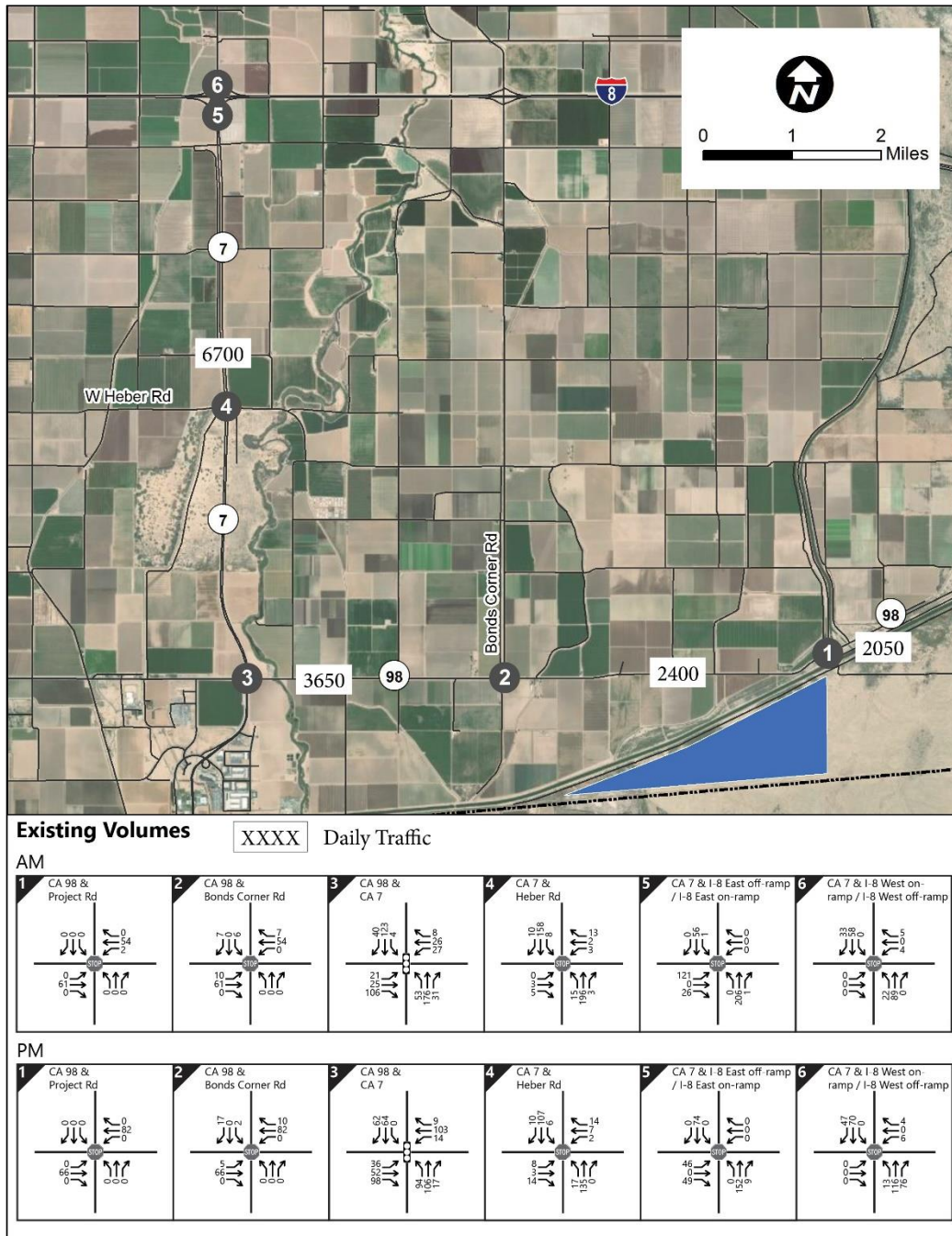
Figure 3.1. Intersection Geometrics



Traffic Volumes

Existing turning movement counts at the study intersections were conducted on Tuesday, December 8, 2020. The existing condition reflects those land uses that were built and occupied at the time of the traffic counts and represent a typical weekday commute period. Intersection turning movement counts are provided in Appendix A. Existing average daily traffic (ADT) segment counts were obtained from the Caltrans for the year 2019. The ADT and weekday a.m. and p.m. peak hour traffic volumes are shown on Figure 3.2.

Figure 3.2. Existing Volumes



Existing Year Conditions

This section documents the existing traffic conditions of study area segments and intersections.

Segments

Roadway segment analysis was conducted for the study area's specified segments. Using average daily traffic (ADT) counts, KOA was able to determine the existing level of service for the designated roadway segments. Table 3.1 below displays these levels of service.

Table 3.1 Existing Year Conditions Roadway Segment Analysis

Roadway Segment	From/ To	Lanes/ Class	LOS E Capacity	Existing		
				ADT	V/C	LOS
SR-98	Project to east	Minor Arterial 2 Lane	18,500	2,050	0.11	A
SR-98	Project to Bonds Corner	Minor Arterial 2 Lane	18,500	2,400	0.13	A
SR 98	Bonds Corner to SR-7	Minor Arterial 2 Lane	18,500	3,650	0.20	A
SR-7	SR-98 to I-8	Principal Arterial 4 Lane	57,000	6,700	0.12	A

Intersections

An intersection LOS analysis was prepared for the existing condition and is summarized in Table 3.2 which indicates that there are two study area intersections. Detailed LOS worksheets are included in Appendix B.

Table 3.2: Existing Year Conditions Peak Hour Intersection Analysis

#	Intersection	Control	AM Peak Hour		PM Peak Hour	
			Delay	LOS	Delay	LOS
1	Site Driveway/ SR-98	NB Stop	0	A	0	A
2	SR-98 / Bonds Corner	SB Stop	8.9	A	8.9	A
3	SR-98 / SR-7	Signal	8.6	A	8.7	A
4	SR-7 / Heber Road	EB/WB Stop	10.1	B	9.6	A
5	SR -7 / I-8 So. Ramps	EB Stop	10.3	B	9.5	A
6	SR-7 / I-8 North Ramps	WB Stop	9.3	A	9.9	A

Delay is in seconds/vehicle. LOS = Level of Service

Freeway Segment Analysis

Table 3.3 displays the freeway segment level of service analysis results under existing conditions.

Table 3.3 Existing Freeway Level of Service

Freeway	Segment	ADT (a)	Peak Direction	# of Lanes	Capacity (b)	D	K	HVF	PK Vol	V/C	LOS
I-8	SR-7 to SR-111	19,700	EB (AM)	2	4,700	11	57	23	1,519	0.32	B
			WB (PM)	2	4700	11	59	23	1,563	0.33	B

- Traffic volumes provided by Caltrans (2019)
- The capacity is calculated as 2,350 per hour/ per main lane
- D = Directional split,| K = Peak hour %
- HVF = Heavy vehicle %. These values were obtained from Caltrans peak hour volume data (2019)
- PK Vol – highest hourly directional volume

4.0 Trip Generation/Trip Distribution

Project Trip Generation

The project trip generation consists of a construction phase and operations phase. Once constructed, the site will not require personnel to be present on-site and will not result in daily trip generation. For this reason, only the trip generation for the construction phase was analyzed.

The construction of the site is estimated to take 12-18 months and would begin in 2022. The number of on-site construction workers for the solar project facilities is not expected to exceed 150 workers at any one time. The number of on-site construction workers for the battery storage facility and the substation is not expected to exceed 100 workers at any one time. The trip generation was estimated if the construction phases were to overlap, so both are included. Delivery trucks are expected to follow the same routes as the construction workers. An estimated two trucks would arrive at the project site each day during the first few weeks of construction of the solar generating facility. Truck trips have been converted into passenger equivalent volumes (PCE) using a PCE factor of 2.5.

Work hours will be between the hours of 8:00 a.m. and 5:00 p.m. Monday through Saturday. The trips generated during the construction phase of construction are shown in Table 4.1.

Table 4.1 Construction Trip Generation – Construction Phase

	Intensity	Unit	Daily Rate (1)	Daily Trips		AM Peak Hour			PM Peak Hour		
						Total	In	Out	Total	In	Out
Solar Construction Workers	150.0	Employee	2	300	Rate	1.00	100%	0%	1.00	0%	100%
					Trips	150	150	0	150	0	150
Battery Storage Workers	100.0	Employee	2	200	Rate	1.00	100%	0%	1.00	0%	100%
					Trips	100	100	0	100	0	100
Construction Truck Trips (PCE)	8.0	Trucks	2.5	20	Rate	0.13	75%	25%	0.13	25%	75%
					Trips	3	2	1	3	1	2
Total				520	Trips	253	252	1	253	1	252

Trip Distribution and Assignment

Trip distribution and assignment is the process of identifying the probable destinations, directions, and traffic routes that project related traffic will likely affect. Trip distribution and assignment information can be estimated from observed traffic patterns, experience or through use of a computerized travel forecast model. Once the proposed developments trips have been estimated, they are assigned to the study area street network. The trip distribution was estimated based on using logical travel paths between the project and local origins. The trip distribution for the project-related trips is shown in Figure 4.1.

Figure 4.1 Trip Distribution



The trip distribution for heavy trucks would require crossing the All America Canal at Gordon Wells Drive. It is estimated that 90% of heavy trucks will travel to the site on eastbound I-8 to the Gordon Wells Drive interchange. The remaining 10% will travel on I-8 westbound. As shown in Table 4.1, only 8 truck trips per day are estimated to use this route.

5.0 Construction Year Conditions

This section documents the analysis for the Project Completion Year conditions. This scenario considers the traffic conditions at the time that the proposed development is constructed by increasing the existing traffic counts by an ambient growth rate to reflect cumulative projects. Projected project only volumes are then added to create the 2023 Baseline with Project Scenario. It is anticipated that the project will be completed in Year 2023. An annual ambient growth of 1.8% was utilized to account for traffic growth between 2020 and 2023.

The growth rate is based on the California Economic Forecast *California County-Level Economic Forecast 2017-2050*, dated September 2017 documents an average annual growth factor of 1.8 percent from 2020 to 2025 for Imperial County. Year 2021 traffic data was obtained by factoring the 2019 traffic counts by the application of the 1.8 percent annual growth (5.4 percent for 2020-23). Figure 5.1 illustrates the Project Construction Year background volumes. Figure 5.2 shows the *Construction Year with Project* traffic volumes in the study area.

This section documents the construction year traffic conditions of study area segments and intersections with and without the project.

Figure 5.1 Construction Year Volumes

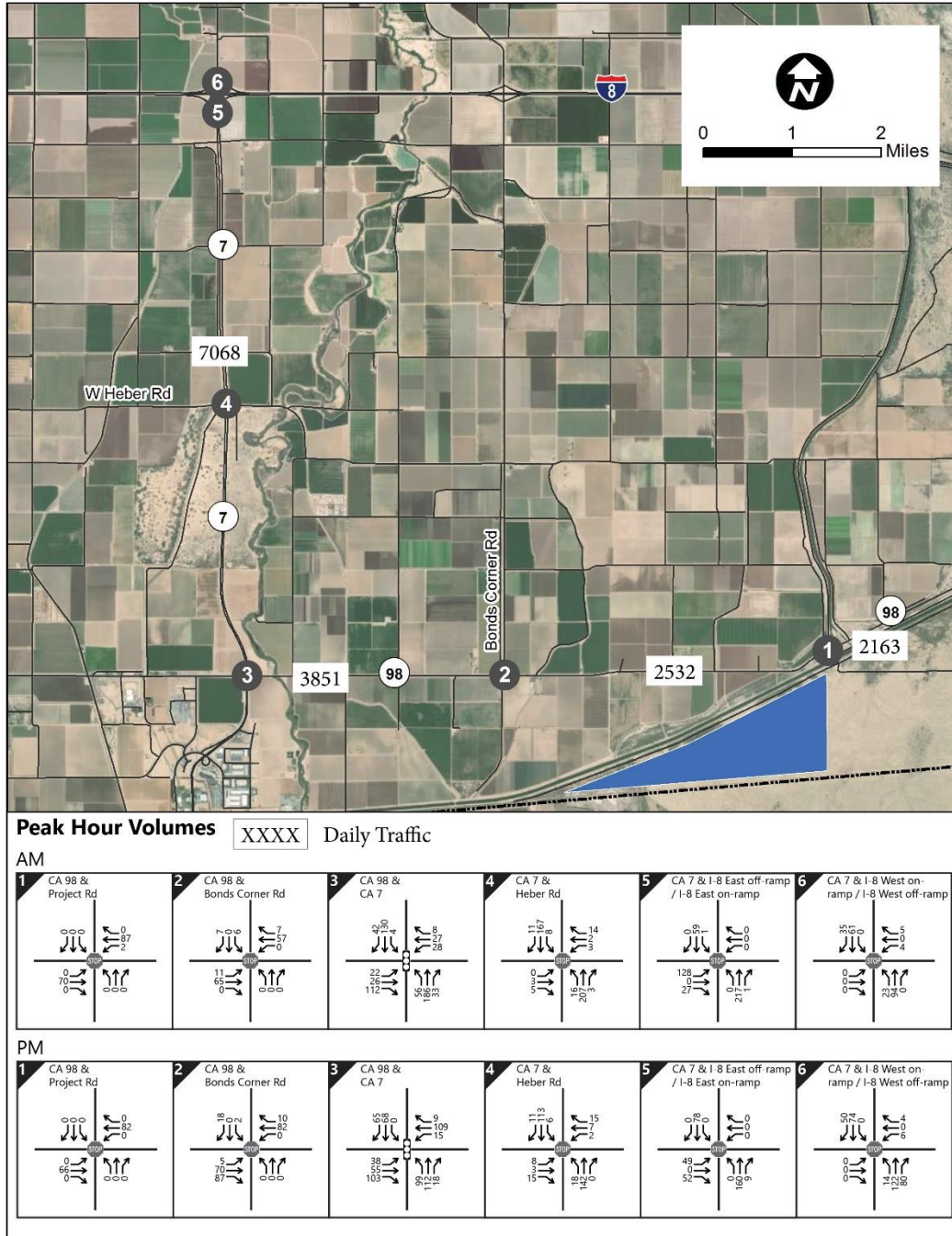
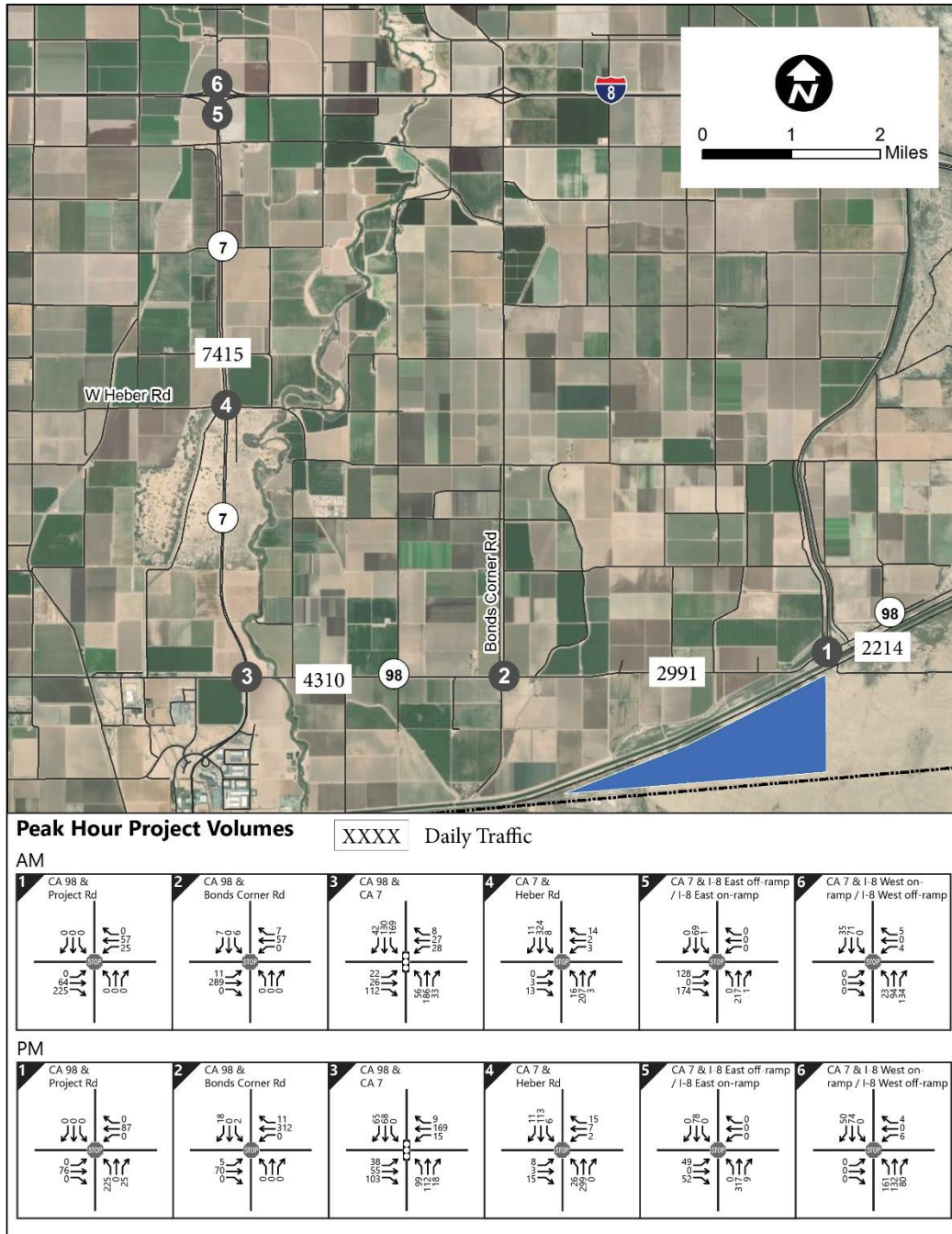


Figure 5.2 Construction Year Plus Project Year Volumes



Segments

Roadway segment analysis was conducted for the study area's specified segments. Using average daily traffic (ADT) counts, KOA determined the opening year level of service for the designated roadway segments.

Summarized in Table 5.1 are Construction Year and Construction Year plus Project roadway segment average daily traffic volumes and their associated LOS on route segments without and with the project under the near term condition. All roadway segments would operate at LOS B or better with and without the project. Therefore, the project would not result in any significant impacts to any segments within the project study area under the construction year condition.

Table 5.1 Construction Year Roadway Segment Analysis

No.	Route	From/To	Lanes/ Class	LOS E Capacity	Project Volumes	Construction Year			Construction Year + Project			Comparison	
						Volume	V/C	LOS	Volume	V/C	LOS	Δ V/C	Sig?
1	SR-98	Project to east	Minor Arterial 2 Lane	18,500	51	2,163	0.12	A	2,214	0.12	A	0.00	No
2	SR-98	Project to Bonds Corner	Minor Arterial 2 Lane	18,500	459	2,532	0.14	A	2,991	0.16	A	0.02	No
3	SR 98	Bonds Corner to SR-7	Minor Arterial 2 Lane	18,500	459	3,851	0.21	A	4,310	0.23	A	0.02	No
4	SR-7	SR-98 to I-8	Principal Arterial 4 Lane	57,000	347	7,068	0.12	A	7,415	0.13	A	0.01	No

Intersections

Table 5.2 summarizes the LOS at each intersection during the AM and PM peak hours under the construction year condition in 2022, without and with the project volumes. The estimated change in project delay associated with the project is also reported. All intersections would operate at a LOS C or better during both AM and PM peak hours with and without the project. Therefore, the project would not result in any significant impacts to any intersections within the project study area under the construction year condition. Detailed LOS worksheets for the Construction Year are included in Appendix C and for the Construction Year plus Project in Appendix D.

Table 5.2 Construction Year Peak Hour Intersection Analysis

No.	Intersection	Control	Construction Year		Construction Year + Project		Change Delay	Significant
			Delay	LOS	Delay	LOS		
AM Peak Hour between 7:00 to 9:00 a.m.								
1	Site Driveway/ SR-98	NB Stop	n/a	A	0.0	A	n/a	N
2	SR-98 / Bonds Corner	SB Stop	9.0	A	9.8	A	0.8	N
3	SR-98 / SR-7	Signal	8.7	A	9.4	A	0.7	N
4	SR-7 / Heber Road	EB/WB Stop	10.2	B	10.3	B	0.1	N
5	SR -7 / I-8 So. Ramps	EB Stop	10.5	B	11.4	B	0.9	N
6	SR-7 / I-8 North Ramps	WB Stop	9.8	A	9.8	A	0.0	N
PM Peak Hour between 4:00 to 6:00 p.m.								
1	Site Driveway/ SR-98	NB Stop	n/a	A	11.4	A	n/a	N
2	SR-98 / Bonds Corner	SB Stop	9.0	A	10.4	A	1.4	N
3	SR-98 / SR-7	Signal	8.8	A	9.0	A	0.5	N
4	SR-7 / Heber Road	EB/WB Stop	9.6	A	10.8	B	1.2	N
5	SR -7 / I-8 So. Ramps	EB Stop	10.0	B	10.0	B	0.0	N
6	SR-7 / I-8 North Ramps	WB Stop	12.6	B	12.6	B	0.0	N

Delay is in seconds/vehicle. LOS = Level of Service

Freeway Segment Analysis

Table 5.3 displays the freeway segment level of service analysis results for the Construction Year and for Construction Year plus Project. This freeway segment would operate at LOS B or better with and without the project. Therefore, the project would not result in any significant impacts to any segments within the project study area under the construction year condition.

Table 5.3 Construction Year Freeway Level of Service

Freeway	Segment	Peak Direction	V/C		Construction Year + Proj		Change V/C	Sig?
			V/C	LOS	V/C	LOS		
I-8	SR-7 to SR-111	EB (AM)	0.34	B	0.39	B	0.05	N
		WB (PM)	0.35	B	0.40	B	0.05	N

6.0 Circulation

The following section discusses the proposed project's access and circulation characteristics.

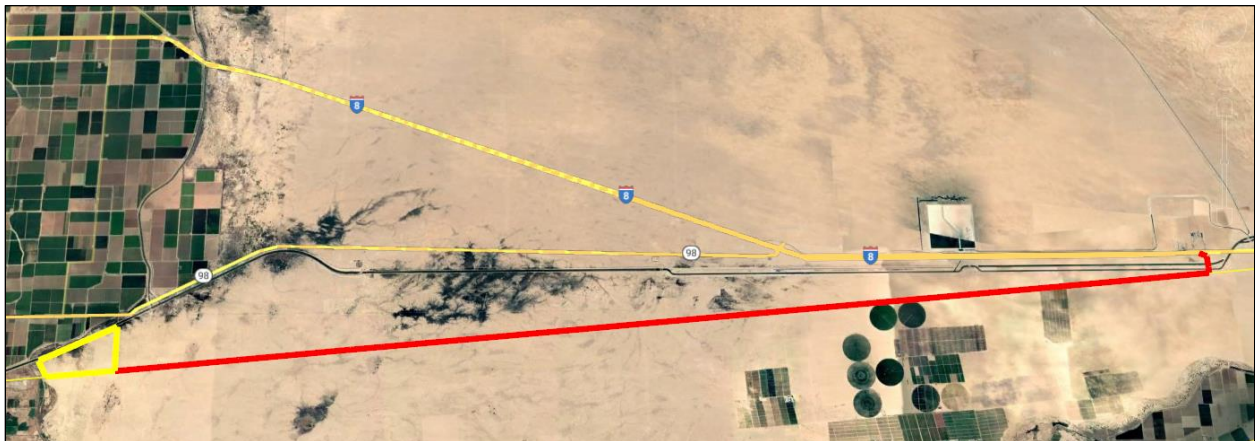
Project Access and Circulation

Access to and from the site will be provided from an existing driveway along SR 98. This will be the primary driveways serving the site. The volumes associated with the development are such that peak hour volumes do not warrant the need for additional storage lanes or storage length for entrances along SR 98. Vehicle storage for vehicles exiting the property will be on-site.

Access for heavy vehicles to and from the site requires crossing the All America Canal which is located parallel and just south of SR-98. Following discussions with the Imperial Irrigation District, it was determined heavy vehicles would cross the canal at Gordon Wells Road located 19 miles east of the project. Gordon Wells Road has an interchange with I-8. The bridge over the Canal was inspected in 2018. The report states that the bridges over the canal were constructed in 2009. The bridge is rated as open with no restrictions. The bridge condition is rated as "Good". The bridge sufficiency rating is 91.9.



Primary Access (located just east of site)



Access at Gordon Wells Road for heavy vehicles



Bridge over north American Canal



Bridge over south American Canal

Parking

The existing parking demand for up to 250 vehicles and for construction equipment will be provided on site.

7.0 Vehicle Miles Travelled

Senate Bill 743 (SB 743) was approved by California legislature in September 2013. SB 743 requires changes to California Environmental Quality Act (CEQA), specifically directing the Governor's Office of Planning and Research (OPR) to develop alternative metrics to the use of vehicular "Level of Service" (LOS) for evaluating transportation projects. OPR has prepared a technical advisory ("OPR Technical Advisory") for evaluating transportation impacts in CEQA and has recommended that Vehicle Miles Traveled (VMT) replace LOS as the primary measure of transportation impacts. The Natural Resources Agency has adopted updates to

CEQA Guidelines to incorporate SB 743 that requires VMT for the purposes of determining a significant transportation impact under CEQA.

Below, are three options for screening projects from project-level assessment as per the OPR guidelines, Technical Advisory on Evaluating Transportation Impacts in CEQA.

Step 1: Transit Priority Area (TPA) Screening

Step 2: Low VMT Area Screening

Step 3: Project Type Screening – yes exempt

Projects generating less than 110 daily vehicle trips. The proposed solar farm project, when constructed, will generate 10 or less daily trips. Based on this criteria, the project can be presumed to have a less than significant impact.

8.0 Impacts and Mitigation

This traffic impact analysis (TIA) has been prepared to identify the potential traffic impacts associated with constructing a solar photovoltaic (PV) energy generation project and utility-scale battery energy storage system (BESS).

The construction of the project is estimated to take 12-18 months and would begin in 2022. During the construction phase, at peak construction, for the time when both the PV and BESS project phases are being constructed as the same time, the project is anticipated to generate a maximum of 520 trip ends per day with 253 AM peak hour trips and 253 PM peak hour trips. Following construction, the project will not generate additional daily or peak hour trips beyond occasional maintenance. The project opening is anticipated to be 2023.

The project is not expected to create significant impacts at study intersections or study segments, therefore no mitigation measures are required. All study intersections and segments were found to operate at LOS C or better for all of the traffic scenarios analyzed.

APPENDIX A: TRAFFIC COUNT DATA

County of Imperial
 N/S: Bonds Corner Road
 E/W: SR-98
 Weather: Clear

File Name : 01_CIM_Bonds Corner_SR98 AM
 Site Code : 04120461
 Start Date : 12/8/2020
 Page No : 1

Groups Printed- Total Volume

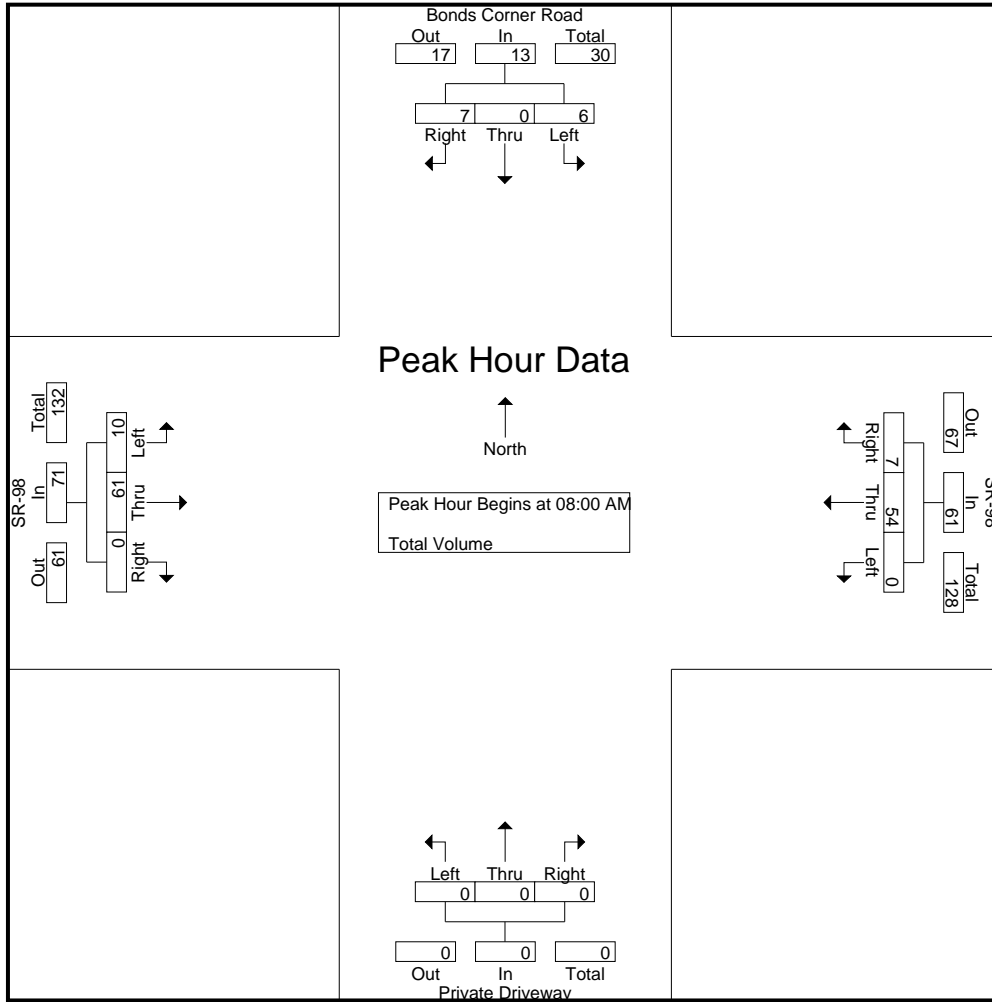
Start Time	Bonds Corner Road Southbound				SR-98 Westbound				Private Driveway Northbound				SR-98 Eastbound				Int. Total
	Left	Thru	Right	App. Total	Left	Thru	Right	App. Total	Left	Thru	Right	App. Total	Left	Thru	Right	App. Total	
07:00 AM	4	0	2	6	0	16	1	17	0	0	0	0	0	12	0	12	35
07:15 AM	0	0	1	1	0	14	2	16	0	0	0	0	0	10	0	10	27
07:30 AM	2	0	2	4	0	11	2	13	0	0	1	1	0	9	0	9	27
07:45 AM	1	0	0	1	0	16	1	17	0	0	0	0	1	11	0	12	30
Total	7	0	5	12	0	57	6	63	0	0	1	1	1	42	0	43	119
08:00 AM	1	0	4	5	0	11	2	13	0	0	0	0	2	15	0	17	35
08:15 AM	1	0	1	2	0	13	1	14	0	0	0	0	1	15	0	16	32
08:30 AM	1	0	2	3	0	17	3	20	0	0	0	0	2	11	0	13	36
08:45 AM	3	0	0	3	0	13	1	14	0	0	0	0	5	20	0	25	42
Total	6	0	7	13	0	54	7	61	0	0	0	0	10	61	0	71	145
Grand Total	13	0	12	25	0	111	13	124	0	0	1	1	11	103	0	114	264
Apprch %	52	0	48		0	89.5	10.5		0	0	100		9.6	90.4	0		
Total %	4.9	0	4.5	9.5	0	42	4.9	47	0	0	0.4	0.4	4.2	39	0	43.2	

Start Time	Bonds Corner Road Southbound				SR-98 Westbound				Private Driveway Northbound				SR-98 Eastbound				Int. Total
	Left	Thru	Right	App. Total	Left	Thru	Right	App. Total	Left	Thru	Right	App. Total	Left	Thru	Right	App. Total	
08:00 AM	1	0	4	5	0	11	2	13	0	0	0	0	2	15	0	17	35
08:15 AM	1	0	1	2	0	13	1	14	0	0	0	0	1	15	0	16	32
08:30 AM	1	0	2	3	0	17	3	20	0	0	0	0	2	11	0	13	36
08:45 AM	3	0	0	3	0	13	1	14	0	0	0	0	5	20	0	25	42
Total Volume	6	0	7	13	0	54	7	61	0	0	0	0	10	61	0	71	145
% App. Total	46.2	0	53.8		0	88.5	11.5		0	0	0		14.1	85.9	0		
PHF	.500	.000	.438	.650	.000	.794	.583	.763	.000	.000	.000	.000	.500	.763	.000	.710	.863

Peak Hour Analysis From 07:00 AM to 08:45 AM - Peak 1 of 1
 Peak Hour for Entire Intersection Begins at 08:00 AM

County of Imperial
 N/S: Bonds Corner Road
 E/W: SR-98
 Weather: Clear

File Name : 01_CIM_Bonds Corner_SR98 AM
 Site Code : 04120461
 Start Date : 12/8/2020
 Page No : 2



Peak Hour Analysis From 07:00 AM to 08:45 AM - Peak 1 of 1
 Peak Hour for Each Approach Begins at:

	08:00 AM				07:45 AM				07:00 AM				08:00 AM			
+0 mins.	1	0	4	5	0	16	1	17	0	0	0	0	2	15	0	17
+15 mins.	1	0	1	2	0	11	2	13	0	0	0	0	1	15	0	16
+30 mins.	1	0	2	3	0	13	1	14	0	0	1	1	2	11	0	13
+45 mins.	3	0	0	3	0	17	3	20	0	0	0	0	5	20	0	25
Total Volume	6	0	7	13	0	57	7	64	0	0	1	1	10	61	0	71
% App. Total	46.2	0	53.8		0	89.1	10.9		0	0	100		14.1	85.9	0	
PHF	.500	.000	.438	.650	.000	.838	.583	.800	.000	.000	.250	.250	.500	.763	.000	.710

County of Imperial
 N/S: Bonds Corner Road
 E/W: SR-98
 Weather: Clear

File Name : 01_CIM_Bonds Corner_SR98 PM
 Site Code : 04120461
 Start Date : 12/8/2020
 Page No : 1

Groups Printed- Total Volume

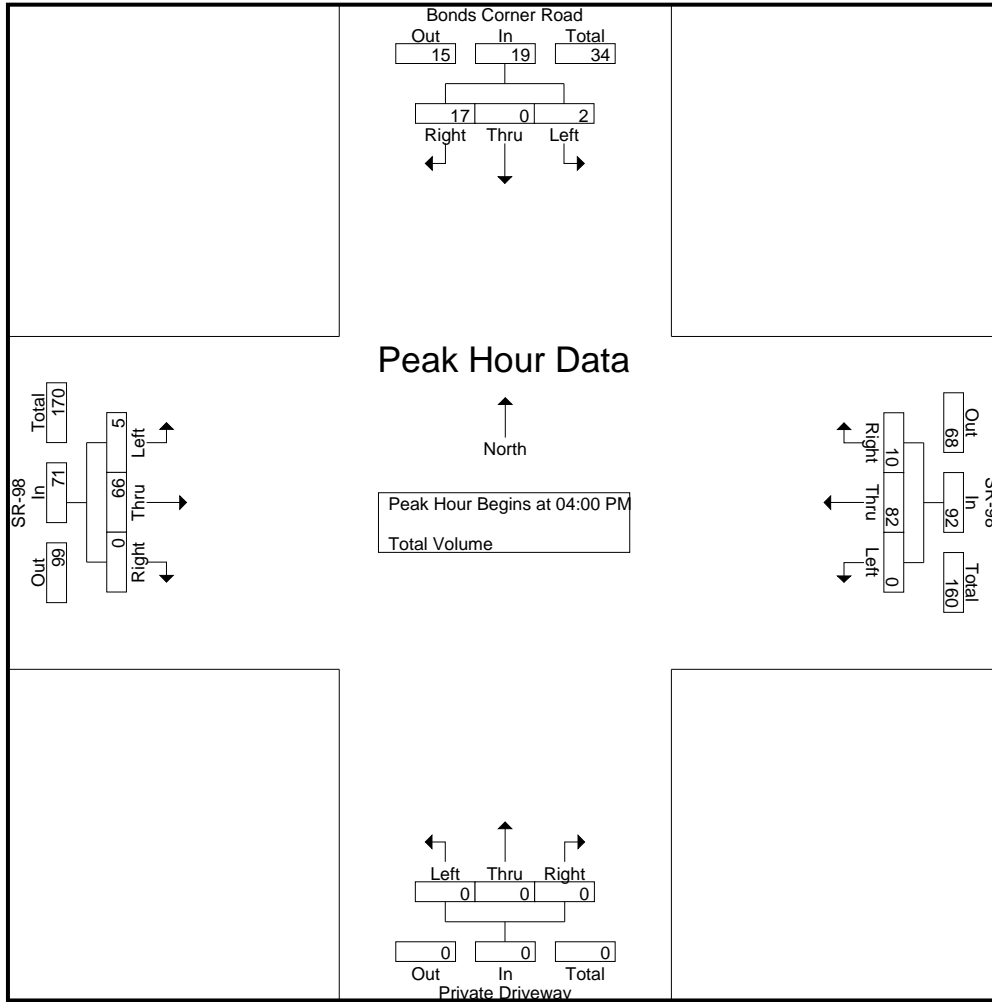
Start Time	Bonds Corner Road Southbound				SR-98 Westbound				Private Driveway Northbound				SR-98 Eastbound				Int. Total
	Left	Thru	Right	App. Total	Left	Thru	Right	App. Total	Left	Thru	Right	App. Total	Left	Thru	Right	App. Total	
04:00 PM	1	0	7	8	0	30	2	32	0	0	0	0	1	25	0	26	66
04:15 PM	0	0	6	6	0	13	2	15	0	0	0	0	1	12	0	13	34
04:30 PM	0	0	3	3	0	23	4	27	0	0	0	0	1	13	0	14	44
04:45 PM	1	0	1	2	0	16	2	18	0	0	0	0	2	16	0	18	38
Total	2	0	17	19	0	82	10	92	0	0	0	0	5	66	0	71	182
05:00 PM	0	0	2	2	0	27	0	27	0	0	0	0	0	13	0	13	42
05:15 PM	1	0	1	2	0	16	0	16	0	0	0	0	0	14	0	14	32
05:30 PM	0	0	2	2	0	25	1	26	0	0	0	0	0	27	0	27	55
05:45 PM	0	0	3	3	0	28	0	28	0	0	0	0	0	9	0	9	40
Total	1	0	8	9	0	96	1	97	0	0	0	0	0	63	0	63	169
Grand Total	3	0	25	28	0	178	11	189	0	0	0	0	5	129	0	134	351
Apprch %	10.7	0	89.3		0	94.2	5.8		0	0	0		3.7	96.3	0		
Total %	0.9	0	7.1	8	0	50.7	3.1	53.8	0	0	0	0	1.4	36.8	0	38.2	

Start Time	Bonds Corner Road Southbound				SR-98 Westbound				Private Driveway Northbound				SR-98 Eastbound				Int. Total
	Left	Thru	Right	App. Total	Left	Thru	Right	App. Total	Left	Thru	Right	App. Total	Left	Thru	Right	App. Total	
04:00 PM	1	0	7	8	0	30	2	32	0	0	0	0	1	25	0	26	66
04:15 PM	0	0	6	6	0	13	2	15	0	0	0	0	1	12	0	13	34
04:30 PM	0	0	3	3	0	23	4	27	0	0	0	0	1	13	0	14	44
04:45 PM	1	0	1	2	0	16	2	18	0	0	0	0	2	16	0	18	38
Total Volume	2	0	17	19	0	82	10	92	0	0	0	0	5	66	0	71	182
% App. Total	10.5	0	89.5		0	89.1	10.9		0	0	0		7	93	0		
PHF	.500	.000	.607	.594	.000	.683	.625	.719	.000	.000	.000	.000	.625	.660	.000	.683	.689

Peak Hour Analysis From 04:00 PM to 05:45 PM - Peak 1 of 1
 Peak Hour for Entire Intersection Begins at 04:00 PM

County of Imperial
 N/S: Bonds Corner Road
 E/W: SR-98
 Weather: Clear

File Name : 01_CIM_Bonds Corner_SR98 PM
 Site Code : 04120461
 Start Date : 12/8/2020
 Page No : 2



Peak Hour Analysis From 04:00 PM to 05:45 PM - Peak 1 of 1
 Peak Hour for Each Approach Begins at:

	04:00 PM				05:00 PM				04:00 PM				04:45 PM			
+0 mins.	1	0	7	8	0	27	0	27	0	0	0	0	2	16	0	18
+15 mins.	0	0	6	6	0	16	0	16	0	0	0	0	0	13	0	13
+30 mins.	0	0	3	3	0	25	1	26	0	0	0	0	0	14	0	14
+45 mins.	1	0	1	2	0	28	0	28	0	0	0	0	0	27	0	27
Total Volume	2	0	17	19	0	96	1	97	0	0	0	0	2	70	0	72
% App. Total	10.5	0	89.5		0	99	1		0	0	0		2.8	97.2	0	
PHF	.500	.000	.607	.594	.000	.857	.250	.866	.000	.000	.000	.000	.250	.648	.000	.667

County of Imperial
 N/S: SR-7
 E/W: SR-98
 Weather: Clear

File Name : 02_CIM_SR-7_SR98 AM
 Site Code : 04120461
 Start Date : 12/8/2020
 Page No : 1

Groups Printed- Total Volume

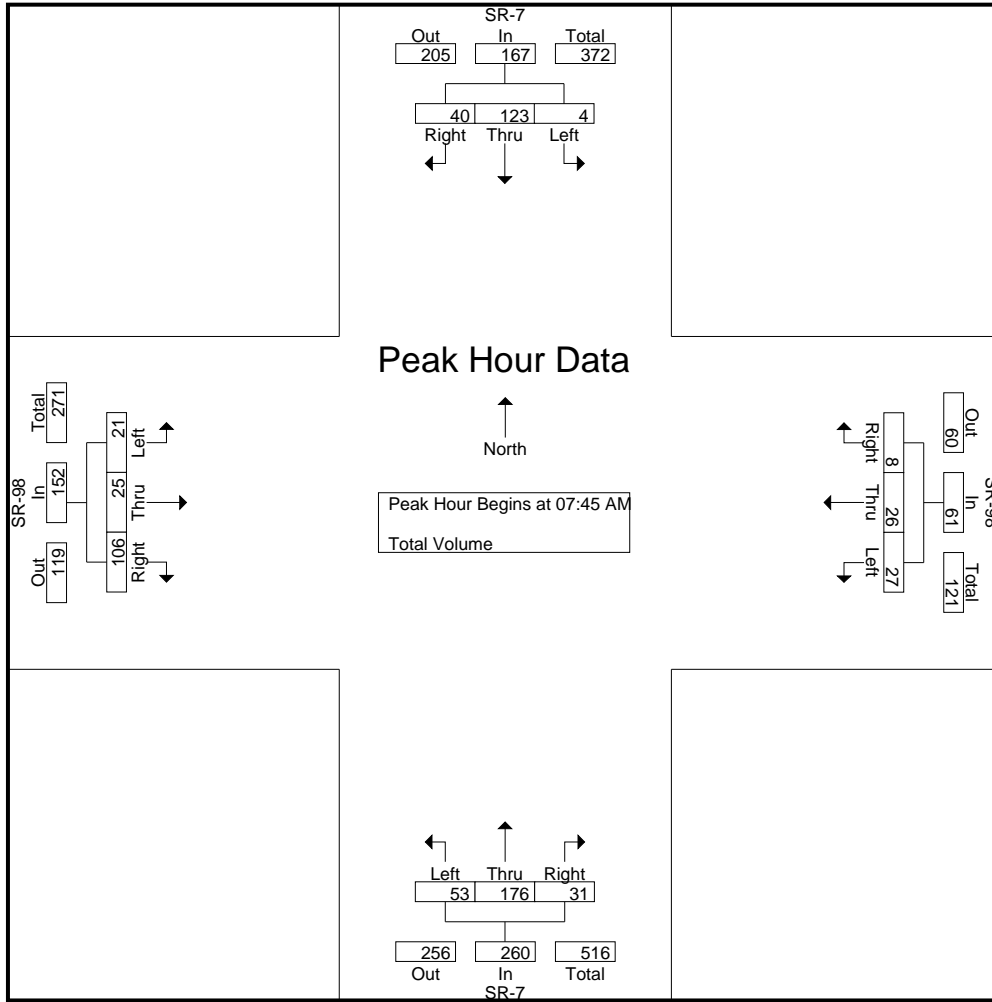
Start Time	SR-7 Southbound				SR-98 Westbound				SR-7 Northbound				SR-98 Eastbound				Int. Total
	Left	Thru	Right	App. Total	Left	Thru	Right	App. Total	Left	Thru	Right	App. Total	Left	Thru	Right	App. Total	
07:00 AM	0	15	9	24	3	12	1	16	10	56	2	68	9	7	12	28	136
07:15 AM	2	27	4	33	4	13	0	17	12	48	7	67	6	4	11	21	138
07:30 AM	5	32	5	42	6	5	1	12	21	43	4	68	7	4	12	23	145
07:45 AM	0	38	15	53	6	7	1	14	13	53	7	73	5	7	34	46	186
Total	7	112	33	152	19	37	3	59	56	200	20	276	27	22	69	118	605
08:00 AM	1	33	8	42	5	6	3	14	9	49	8	66	4	7	34	45	167
08:15 AM	2	20	9	31	7	5	1	13	17	37	8	62	6	5	20	31	137
08:30 AM	1	32	8	41	9	8	3	20	14	37	8	59	6	6	18	30	150
08:45 AM	0	26	8	34	7	5	1	13	8	36	15	59	5	7	20	32	138
Total	4	111	33	148	28	24	8	60	48	159	39	246	21	25	92	138	592
Grand Total	11	223	66	300	47	61	11	119	104	359	59	522	48	47	161	256	1197
Apprch %	3.7	74.3	22		39.5	51.3	9.2		19.9	68.8	11.3		18.8	18.4	62.9		
Total %	0.9	18.6	5.5	25.1	3.9	5.1	0.9	9.9	8.7	30	4.9	43.6	4	3.9	13.5	21.4	

Start Time	SR-7 Southbound				SR-98 Westbound				SR-7 Northbound				SR-98 Eastbound				Int. Total
	Left	Thru	Right	App. Total	Left	Thru	Right	App. Total	Left	Thru	Right	App. Total	Left	Thru	Right	App. Total	
07:45 AM	0	38	15	53	6	7	1	14	13	53	7	73	5	7	34	46	186
08:00 AM	1	33	8	42	5	6	3	14	9	49	8	66	4	7	34	45	167
08:15 AM	2	20	9	31	7	5	1	13	17	37	8	62	6	5	20	31	137
08:30 AM	1	32	8	41	9	8	3	20	14	37	8	59	6	6	18	30	150
Total Volume	4	123	40	167	27	26	8	61	53	176	31	260	21	25	106	152	640
% App. Total	2.4	73.7	24		44.3	42.6	13.1		20.4	67.7	11.9		13.8	16.4	69.7		
PHF	.500	.809	.667	.788	.750	.813	.667	.763	.779	.830	.969	.890	.875	.893	.779	.826	.860

Peak Hour Analysis From 07:00 AM to 08:45 AM - Peak 1 of 1
 Peak Hour for Entire Intersection Begins at 07:45 AM

County of Imperial
 N/S: SR-7
 E/W: SR-98
 Weather: Clear

File Name : 02_CIM_SR-7_SR98 AM
 Site Code : 04120461
 Start Date : 12/8/2020
 Page No : 2



Peak Hour Analysis From 07:00 AM to 08:45 AM - Peak 1 of 1
 Peak Hour for Each Approach Begins at:

	07:15 AM				07:45 AM				07:00 AM				07:45 AM			
+0 mins.	2	27	4	33	6	7	1	14	10	56	2	68	5	7	34	46
+15 mins.	5	32	5	42	5	6	3	14	12	48	7	67	4	7	34	45
+30 mins.	0	38	15	53	7	5	1	13	21	43	4	68	6	5	20	31
+45 mins.	1	33	8	42	9	8	3	20	13	53	7	73	6	6	18	30
Total Volume	8	130	32	170	27	26	8	61	56	200	20	276	21	25	106	152
% App. Total	4.7	76.5	18.8		44.3	42.6	13.1		20.3	72.5	7.2		13.8	16.4	69.7	
PHF	.400	.855	.533	.802	.750	.813	.667	.763	.667	.893	.714	.945	.875	.893	.779	.826

County of Imperial
 N/S: SR-7
 E/W: SR-98
 Weather: Clear

File Name : 02_CIM_SR-7_SR98 PM
 Site Code : 04120461
 Start Date : 12/8/2020
 Page No : 1

Groups Printed- Total Volume

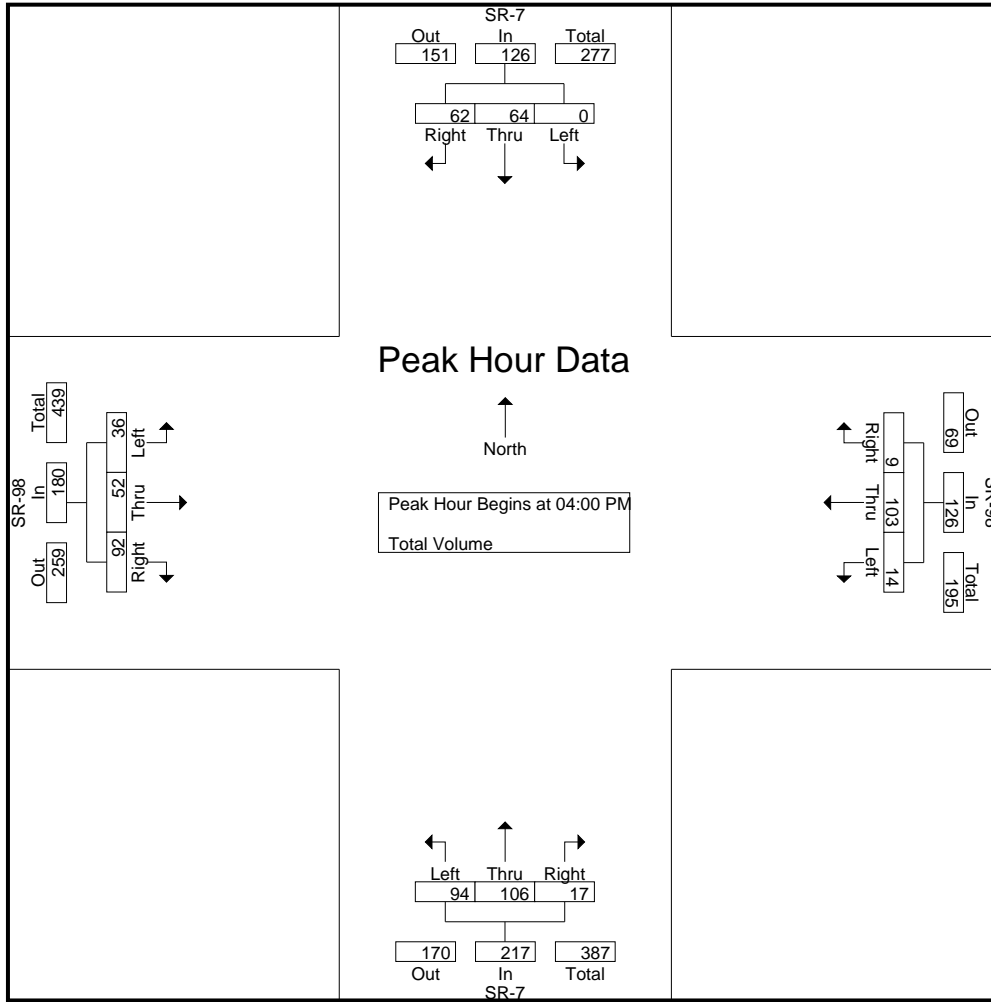
Start Time	SR-7 Southbound				SR-98 Westbound				SR-7 Northbound				SR-98 Eastbound				Int. Total
	Left	Thru	Right	App. Total	Left	Thru	Right	App. Total	Left	Thru	Right	App. Total	Left	Thru	Right	App. Total	
04:00 PM	0	19	21	40	4	43	2	49	23	34	8	65	13	16	23	52	206
04:15 PM	0	19	8	27	3	23	2	28	36	34	3	73	11	10	25	46	174
04:30 PM	0	11	21	32	4	13	3	20	25	18	4	47	5	11	30	46	145
04:45 PM	0	15	12	27	3	24	2	29	10	20	2	32	7	15	14	36	124
Total	0	64	62	126	14	103	9	126	94	106	17	217	36	52	92	180	649
05:00 PM	1	13	7	21	4	25	0	29	71	26	2	99	7	9	22	38	187
05:15 PM	1	10	18	29	7	16	0	23	30	17	2	49	7	17	23	47	148
05:30 PM	0	16	8	24	2	22	0	24	24	19	4	47	3	13	15	31	126
05:45 PM	0	17	9	26	7	23	1	31	13	7	1	21	11	13	13	37	115
Total	2	56	42	100	20	86	1	107	138	69	9	216	28	52	73	153	576
Grand Total	2	120	104	226	34	189	10	233	232	175	26	433	64	104	165	333	1225
Apprch %	0.9	53.1	46		14.6	81.1	4.3		53.6	40.4	6		19.2	31.2	49.5		
Total %	0.2	9.8	8.5	18.4	2.8	15.4	0.8	19	18.9	14.3	2.1	35.3	5.2	8.5	13.5	27.2	

Start Time	SR-7 Southbound				SR-98 Westbound				SR-7 Northbound				SR-98 Eastbound				Int. Total
	Left	Thru	Right	App. Total	Left	Thru	Right	App. Total	Left	Thru	Right	App. Total	Left	Thru	Right	App. Total	
04:00 PM	0	19	21	40	4	43	2	49	23	34	8	65	13	16	23	52	206
04:15 PM	0	19	8	27	3	23	2	28	36	34	3	73	11	10	25	46	174
04:30 PM	0	11	21	32	4	13	3	20	25	18	4	47	5	11	30	46	145
04:45 PM	0	15	12	27	3	24	2	29	10	20	2	32	7	15	14	36	124
Total Volume	0	64	62	126	14	103	9	126	94	106	17	217	36	52	92	180	649
% App. Total	0	50.8	49.2		11.1	81.7	7.1		43.3	48.8	7.8		20	28.9	51.1		
PHF	.000	.842	.738	.788	.875	.599	.750	.643	.653	.779	.531	.743	.692	.813	.767	.865	.788

Peak Hour Analysis From 04:00 PM to 05:45 PM - Peak 1 of 1
 Peak Hour for Entire Intersection Begins at 04:00 PM

County of Imperial
 N/S: SR-7
 E/W: SR-98
 Weather: Clear

File Name : 02_CIM_SR-7_SR98 PM
 Site Code : 04120461
 Start Date : 12/8/2020
 Page No : 2



Peak Hour Analysis From 04:00 PM to 05:45 PM - Peak 1 of 1
 Peak Hour for Each Approach Begins at:

	04:00 PM				04:00 PM				04:15 PM				04:00 PM			
+0 mins.	0	19	21	40	4	43	2	49	36	34	3	73	13	16	23	52
+15 mins.	0	19	8	27	3	23	2	28	25	18	4	47	11	10	25	46
+30 mins.	0	11	21	32	4	13	3	20	10	20	2	32	5	11	30	46
+45 mins.	0	15	12	27	3	24	2	29	71	26	2	99	7	15	14	36
Total Volume	0	64	62	126	14	103	9	126	142	98	11	251	36	52	92	180
% App. Total	0	50.8	49.2		11.1	81.7	7.1		56.6	39	4.4		20	28.9	51.1	
PHF	.000	.842	.738	.788	.875	.599	.750	.643	.500	.721	.688	.634	.692	.813	.767	.865

County of Imperial
 N/S: SR-7
 E/W: Herber Road
 Weather: Clear

File Name : 03_CIM_SR-7_Herber AM
 Site Code : 04120461
 Start Date : 12/8/2020
 Page No : 1

Groups Printed- Total Volume

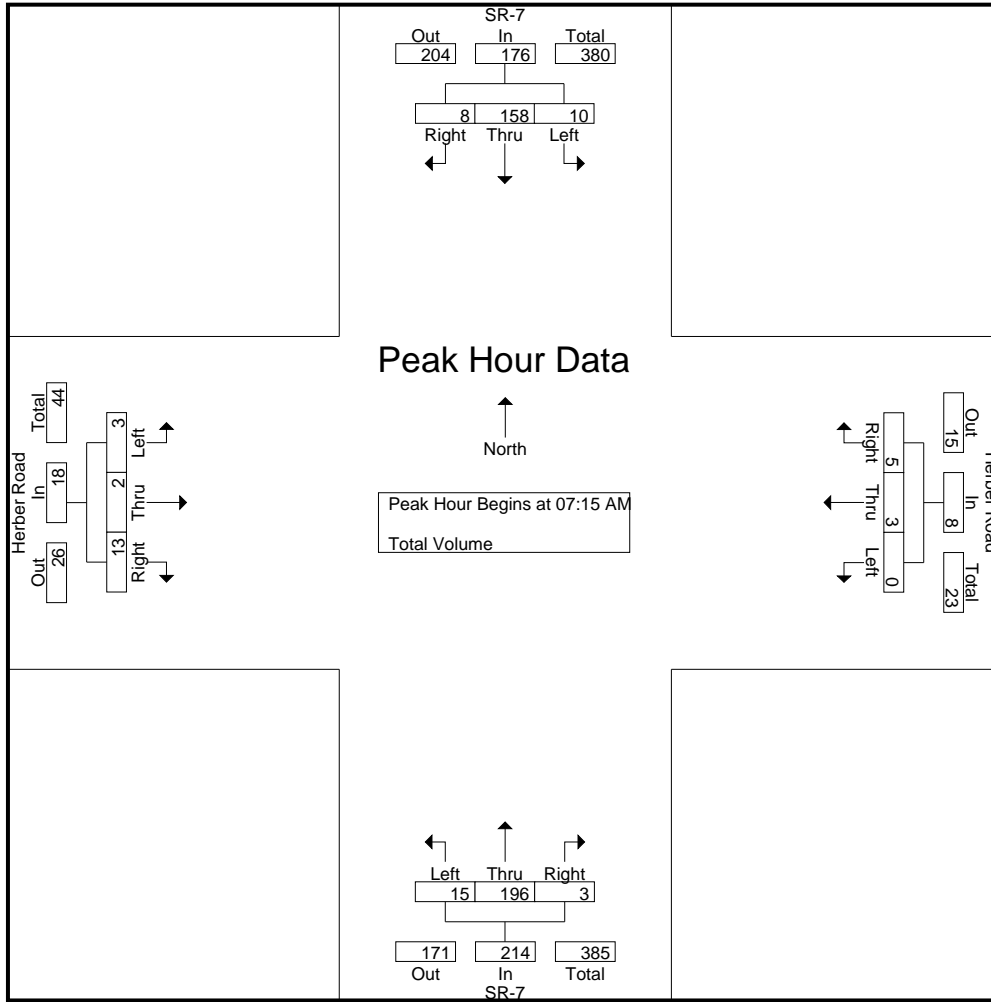
Start Time	SR-7 Southbound				Herber Road Westbound				SR-7 Northbound				Herber Road Eastbound				Int. Total
	Left	Thru	Right	App. Total	Left	Thru	Right	App. Total	Left	Thru	Right	App. Total	Left	Thru	Right	App. Total	
07:00 AM	0	31	2	33	0	1	2	3	0	57	0	57	0	0	0	0	93
07:15 AM	0	32	2	34	0	1	2	3	2	49	1	52	1	0	4	5	94
07:30 AM	4	43	0	47	0	2	1	3	5	44	1	50	1	1	4	6	106
07:45 AM	2	48	5	55	0	0	0	0	4	52	1	57	0	0	3	3	115
Total	6	154	9	169	0	4	5	9	11	202	3	216	2	1	11	14	408
08:00 AM	4	35	1	40	0	0	2	2	4	51	0	55	1	1	2	4	101
08:15 AM	4	32	0	36	0	3	1	4	4	41	0	45	5	3	1	9	94
08:30 AM	2	35	5	42	0	1	5	6	1	43	0	44	1	2	3	6	98
08:45 AM	2	38	1	41	0	1	2	3	4	39	0	43	1	0	0	1	88
Total	12	140	7	159	0	5	10	15	13	174	0	187	8	6	6	20	381
Grand Total	18	294	16	328	0	9	15	24	24	376	3	403	10	7	17	34	789
Apprch %	5.5	89.6	4.9		0	37.5	62.5		6	93.3	0.7		29.4	20.6	50		
Total %	2.3	37.3	2	41.6	0	1.1	1.9	3	3	47.7	0.4	51.1	1.3	0.9	2.2	4.3	

Start Time	SR-7 Southbound				Herber Road Westbound				SR-7 Northbound				Herber Road Eastbound				Int. Total
	Left	Thru	Right	App. Total	Left	Thru	Right	App. Total	Left	Thru	Right	App. Total	Left	Thru	Right	App. Total	
07:15 AM	0	32	2	34	0	1	2	3	2	49	1	52	1	0	4	5	94
07:30 AM	4	43	0	47	0	2	1	3	5	44	1	50	1	1	4	6	106
07:45 AM	2	48	5	55	0	0	0	0	4	52	1	57	0	0	3	3	115
08:00 AM	4	35	1	40	0	0	2	2	4	51	0	55	1	1	2	4	101
Total Volume	10	158	8	176	0	3	5	8	15	196	3	214	3	2	13	18	416
% App. Total	5.7	89.8	4.5		0	37.5	62.5		7	91.6	1.4		16.7	11.1	72.2		
PHF	.625	.823	.400	.800	.000	.375	.625	.667	.750	.942	.750	.939	.750	.500	.813	.750	.904

Peak Hour Analysis From 07:00 AM to 08:45 AM - Peak 1 of 1
 Peak Hour for Entire Intersection Begins at 07:15 AM

County of Imperial
 N/S: SR-7
 E/W: Herber Road
 Weather: Clear

File Name : 03_CIM_SR-7_Herber AM
 Site Code : 04120461
 Start Date : 12/8/2020
 Page No : 2



Peak Hour Analysis From 07:00 AM to 08:45 AM - Peak 1 of 1
 Peak Hour for Each Approach Begins at:

	07:30 AM				08:00 AM				07:00 AM				07:30 AM			
+0 mins.	4	43	0	47	0	0	2	2	0	57	0	57	1	1	4	6
+15 mins.	2	48	5	55	0	3	1	4	2	49	1	52	0	0	3	3
+30 mins.	4	35	1	40	0	1	5	6	5	44	1	50	1	1	2	4
+45 mins.	4	32	0	36	0	1	2	3	4	52	1	57	5	3	1	9
Total Volume	14	158	6	178	0	5	10	15	11	202	3	216	7	5	10	22
% App. Total	7.9	88.8	3.4		0	33.3	66.7		5.1	93.5	1.4		31.8	22.7	45.5	
PHF	.875	.823	.300	.809	.000	.417	.500	.625	.550	.886	.750	.947	.350	.417	.625	.611

County of Imperial
 N/S: SR-7
 E/W: Herber Road
 Weather: Clear

File Name : 03_CIM_SR-7_Herber PM
 Site Code : 04120461
 Start Date : 12/8/2020
 Page No : 1

Groups Printed- Total Volume

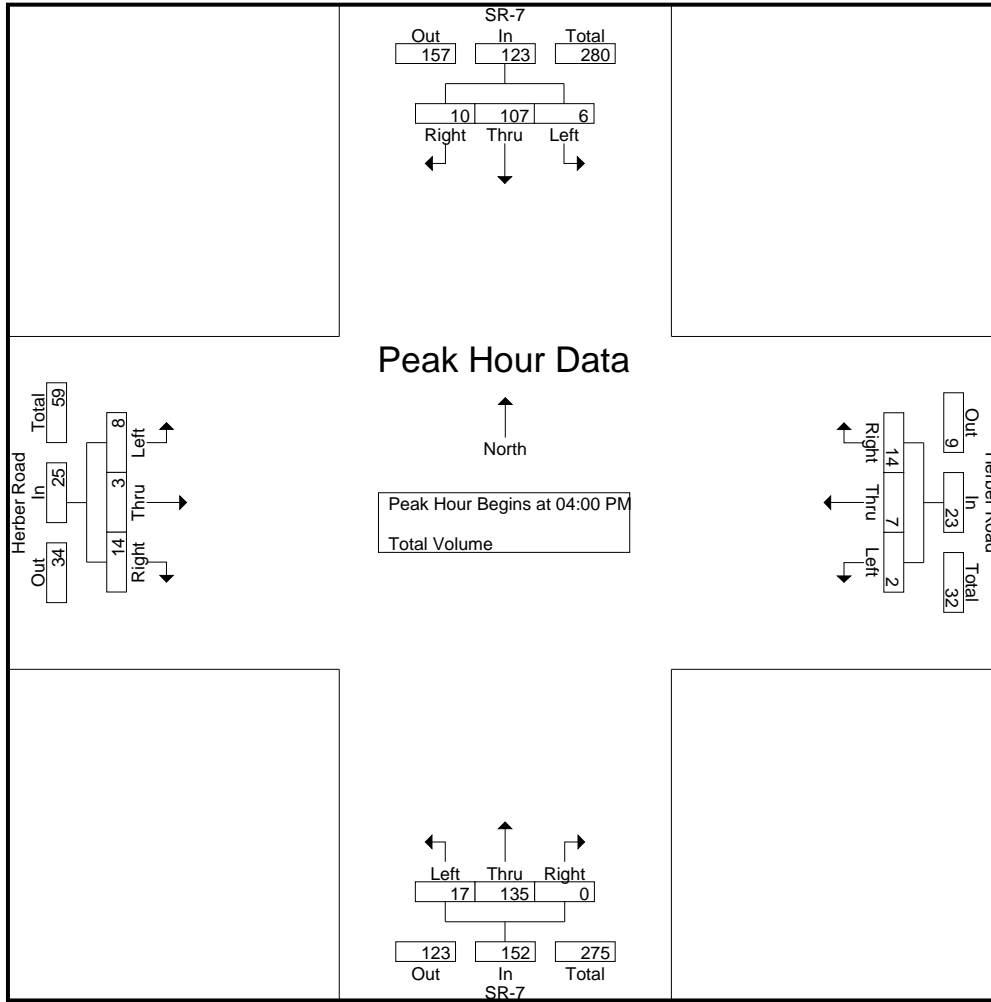
Start Time	SR-7 Southbound				Herber Road Westbound				SR-7 Northbound				Herber Road Eastbound				Int. Total
	Left	Thru	Right	App. Total	Left	Thru	Right	App. Total	Left	Thru	Right	App. Total	Left	Thru	Right	App. Total	
04:00 PM	3	31	3	37	1	3	9	13	5	39	0	44	4	0	2	6	100
04:15 PM	3	25	2	30	1	0	2	3	3	48	0	51	2	1	4	7	91
04:30 PM	0	30	3	33	0	3	0	3	5	22	0	27	2	2	4	8	71
04:45 PM	0	21	2	23	0	1	3	4	4	26	0	30	0	0	4	4	61
Total	6	107	10	123	2	7	14	23	17	135	0	152	8	3	14	25	323
05:00 PM	0	18	3	21	0	0	1	1	5	24	0	29	3	2	4	9	60
05:15 PM	1	29	3	33	0	1	2	3	4	22	0	26	0	0	1	1	63
05:30 PM	1	24	0	25	0	0	0	0	3	21	0	24	4	0	3	7	56
05:45 PM	1	19	1	21	0	1	1	2	0	18	0	18	1	0	4	5	46
Total	3	90	7	100	0	2	4	6	12	85	0	97	8	2	12	22	225
Grand Total	9	197	17	223	2	9	18	29	29	220	0	249	16	5	26	47	548
Apprch %	4	88.3	7.6		6.9	31	62.1		11.6	88.4	0		34	10.6	55.3		
Total %	1.6	35.9	3.1	40.7	0.4	1.6	3.3	5.3	5.3	40.1	0	45.4	2.9	0.9	4.7	8.6	

Start Time	SR-7 Southbound				Herber Road Westbound				SR-7 Northbound				Herber Road Eastbound				Int. Total
	Left	Thru	Right	App. Total	Left	Thru	Right	App. Total	Left	Thru	Right	App. Total	Left	Thru	Right	App. Total	
04:00 PM	3	31	3	37	1	3	9	13	5	39	0	44	4	0	2	6	100
04:15 PM	3	25	2	30	1	0	2	3	3	48	0	51	2	1	4	7	91
04:30 PM	0	30	3	33	0	3	0	3	5	22	0	27	2	2	4	8	71
04:45 PM	0	21	2	23	0	1	3	4	4	26	0	30	0	0	4	4	61
Total Volume	6	107	10	123	2	7	14	23	17	135	0	152	8	3	14	25	323
% App. Total	4.9	87	8.1		8.7	30.4	60.9		11.2	88.8	0		32	12	56		
PHF	.500	.863	.833	.831	.500	.583	.389	.442	.850	.703	.000	.745	.500	.375	.875	.781	.808

Peak Hour Analysis From 04:00 PM to 05:45 PM - Peak 1 of 1
 Peak Hour for Entire Intersection Begins at 04:00 PM

County of Imperial
 N/S: SR-7
 E/W: Herber Road
 Weather: Clear

File Name : 03_CIM_SR-7_Herber PM
 Site Code : 04120461
 Start Date : 12/8/2020
 Page No : 2



Peak Hour Analysis From 04:00 PM to 05:45 PM - Peak 1 of 1
 Peak Hour for Each Approach Begins at:

	04:00 PM				04:00 PM				04:00 PM				04:15 PM			
+0 mins.	3	31	3	37	1	3	9	13	5	39	0	44	2	1	4	7
+15 mins.	3	25	2	30	1	0	2	3	3	48	0	51	2	2	4	8
+30 mins.	0	30	3	33	0	3	0	3	5	22	0	27	0	0	4	4
+45 mins.	0	21	2	23	0	1	3	4	4	26	0	30	3	2	4	9
Total Volume	6	107	10	123	2	7	14	23	17	135	0	152	7	5	16	28
% App. Total	4.9	87	8.1		8.7	30.4	60.9		11.2	88.8	0		25	17.9	57.1	
PHF	.500	.863	.833	.831	.500	.583	.389	.442	.850	.703	.000	.745	.583	.625	1.000	.778

County of Imperial
 N/S: SR-7
 E/W: I-8 Eastbound Ramps
 Weather: Clear

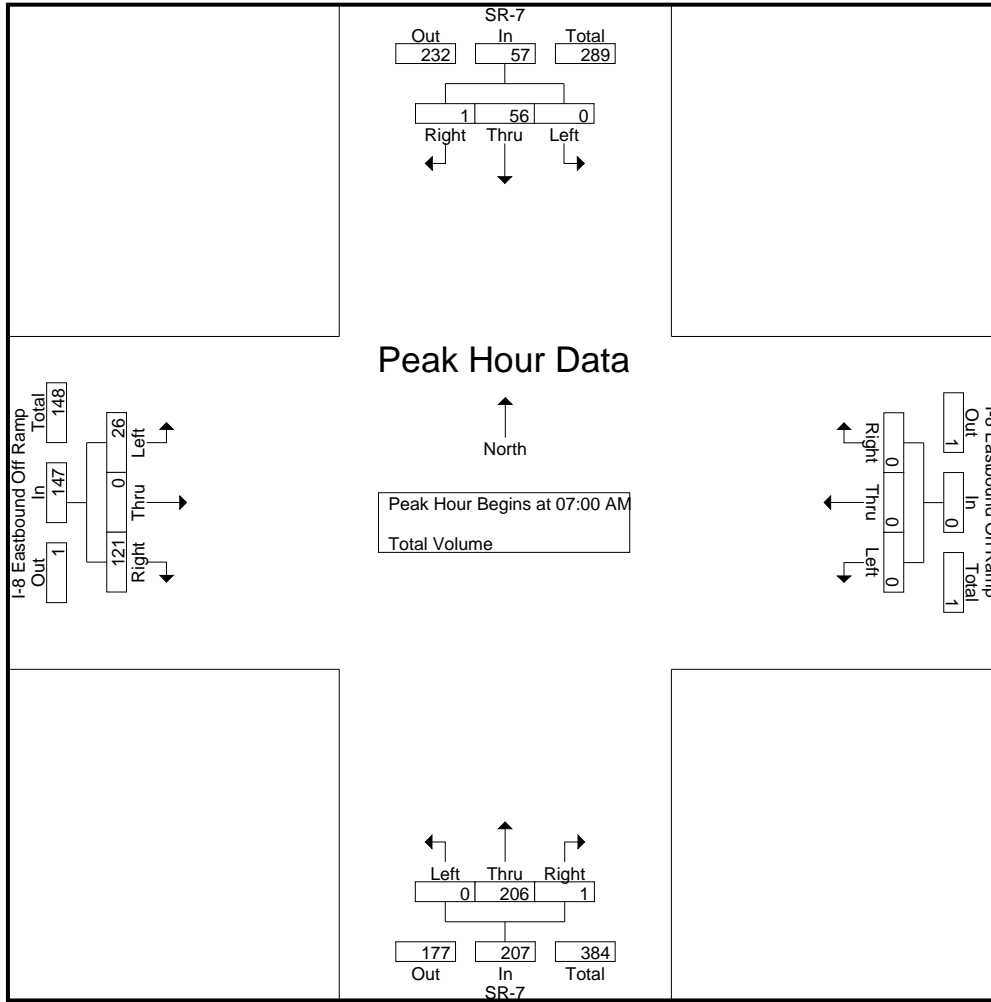
File Name : 04_CIM_SR-7_I-8E AM
 Site Code : 04120461
 Start Date : 12/8/2020
 Page No : 1

Groups Printed- Total Volume

Start Time	SR-7 Southbound				I-8 Eastbound On Ramp Westbound				SR-7 Northbound				I-8 Eastbound Off Ramp Eastbound				Int. Total
	Left	Thru	Right	App. Total	Left	Thru	Right	App. Total	Left	Thru	Right	App. Total	Left	Thru	Right	App. Total	
07:00 AM	0	13	1	14	0	0	0	0	0	61	1	62	6	0	34	40	116
07:15 AM	0	7	0	7	0	0	0	0	0	55	0	55	7	0	17	24	86
07:30 AM	0	20	0	20	0	0	0	0	0	45	0	45	6	0	36	42	107
07:45 AM	0	16	0	16	0	0	0	0	0	45	0	45	7	0	34	41	102
Total	0	56	1	57	0	0	0	0	0	206	1	207	26	0	121	147	411
08:00 AM	0	10	0	10	0	0	0	0	0	52	2	54	6	0	17	23	87
08:15 AM	0	13	0	13	0	0	0	0	0	36	3	39	6	0	24	30	82
08:30 AM	0	21	1	22	0	0	0	0	0	40	2	42	4	0	24	28	92
08:45 AM	0	15	1	16	0	0	0	0	0	47	1	48	8	0	28	36	100
Total	0	59	2	61	0	0	0	0	0	175	8	183	24	0	93	117	361
Grand Total	0	115	3	118	0	0	0	0	0	381	9	390	50	0	214	264	772
Apprch %	0	97.5	2.5		0	0	0		0	97.7	2.3		18.9	0	81.1		
Total %	0	14.9	0.4	15.3	0	0	0		0	49.4	1.2	50.5	6.5	0	27.7	34.2	

Start Time	SR-7 Southbound				I-8 Eastbound On Ramp Westbound				SR-7 Northbound				I-8 Eastbound Off Ramp Eastbound				Int. Total
	Left	Thru	Right	App. Total	Left	Thru	Right	App. Total	Left	Thru	Right	App. Total	Left	Thru	Right	App. Total	
07:00 AM	0	13	1	14	0	0	0	0	0	61	1	62	6	0	34	40	116
07:15 AM	0	7	0	7	0	0	0	0	0	55	0	55	7	0	17	24	86
07:30 AM	0	20	0	20	0	0	0	0	0	45	0	45	6	0	36	42	107
07:45 AM	0	16	0	16	0	0	0	0	0	45	0	45	7	0	34	41	102
Total Volume	0	56	1	57	0	0	0	0	0	206	1	207	26	0	121	147	411
% App. Total	0	98.2	1.8		0	0	0		0	99.5	0.5		17.7	0	82.3		
PHF	.000	.700	.250	.713	.000	.000	.000	.000	.000	.844	.250	.835	.929	.000	.840	.875	.886

Peak Hour Analysis From 07:00 AM to 08:45 AM - Peak 1 of 1
 Peak Hour for Entire Intersection Begins at 07:00 AM



Peak Hour Analysis From 07:00 AM to 08:45 AM - Peak 1 of 1
 Peak Hour for Each Approach Begins at:

	07:45 AM				07:00 AM				07:00 AM				07:00 AM			
+0 mins.	0	16	0	16	0	0	0	0	0	61	1	62	6	0	34	40
+15 mins.	0	10	0	10	0	0	0	0	0	55	0	55	7	0	17	24
+30 mins.	0	13	0	13	0	0	0	0	0	45	0	45	6	0	36	42
+45 mins.	0	21	1	22	0	0	0	0	0	45	0	45	7	0	34	41
Total Volume	0	60	1	61	0	0	0	0	0	206	1	207	26	0	121	147
% App. Total	0	98.4	1.6		0	0	0		0	99.5	0.5		17.7	0	82.3	
PHF	.000	.714	.250	.693	.000	.000	.000	.000	.000	.844	.250	.835	.929	.000	.840	.875

County of Imperial
 N/S: SR-7
 E/W: I-8 Eastbound Ramps
 Weather: Clear

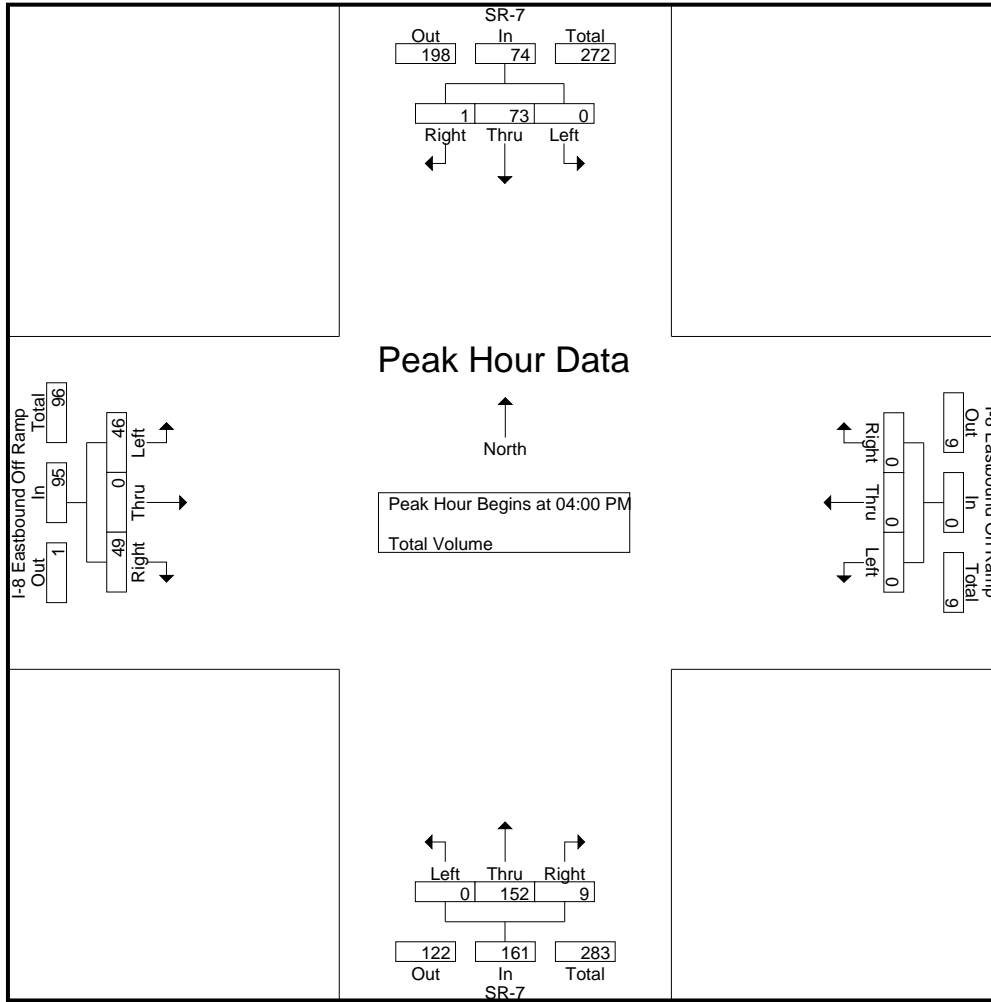
File Name : 04_CIM_SR-7_I-8E PM
 Site Code : 04120461
 Start Date : 12/8/2020
 Page No : 1

Groups Printed- Total Volume

Start Time	SR-7 Southbound				I-8 Eastbound On Ramp Westbound				SR-7 Northbound				I-8 Eastbound Off Ramp Eastbound				Int. Total
	Left	Thru	Right	App. Total	Left	Thru	Right	App. Total	Left	Thru	Right	App. Total	Left	Thru	Right	App. Total	
04:00 PM	0	23	0	23	0	0	0	0	0	49	2	51	6	0	14	20	94
04:15 PM	0	17	0	17	0	0	0	0	0	49	4	53	14	0	12	26	96
04:30 PM	0	22	1	23	0	0	0	0	0	25	1	26	18	0	12	30	79
04:45 PM	0	11	0	11	0	0	0	0	0	29	2	31	8	0	11	19	61
Total	0	73	1	74	0	0	0	0	0	152	9	161	46	0	49	95	330
05:00 PM	0	18	2	20	0	0	0	0	0	27	2	29	18	0	9	27	76
05:15 PM	0	14	3	17	0	0	0	0	0	20	1	21	18	0	15	33	71
05:30 PM	0	15	1	16	0	0	0	0	0	24	0	24	23	0	10	33	73
05:45 PM	0	13	0	13	0	0	0	0	0	21	2	23	14	0	9	23	59
Total	0	60	6	66	0	0	0	0	0	92	5	97	73	0	43	116	279
Grand Total	0	133	7	140	0	0	0	0	0	244	14	258	119	0	92	211	609
Apprch %	0	95	5		0	0	0		0	94.6	5.4		56.4	0	43.6		
Total %	0	21.8	1.1	23	0	0	0	0	0	40.1	2.3	42.4	19.5	0	15.1	34.6	

Start Time	SR-7 Southbound				I-8 Eastbound On Ramp Westbound				SR-7 Northbound				I-8 Eastbound Off Ramp Eastbound				Int. Total
	Left	Thru	Right	App. Total	Left	Thru	Right	App. Total	Left	Thru	Right	App. Total	Left	Thru	Right	App. Total	
04:00 PM	0	23	0	23	0	0	0	0	0	49	2	51	6	0	14	20	94
04:15 PM	0	17	0	17	0	0	0	0	0	49	4	53	14	0	12	26	96
04:30 PM	0	22	1	23	0	0	0	0	0	25	1	26	18	0	12	30	79
04:45 PM	0	11	0	11	0	0	0	0	0	29	2	31	8	0	11	19	61
Total Volume	0	73	1	74	0	0	0	0	0	152	9	161	46	0	49	95	330
% App. Total	0	98.6	1.4		0	0	0		0	94.4	5.6		48.4	0	51.6		
PHF	.000	.793	.250	.804	.000	.000	.000	.000	.000	.776	.563	.759	.639	.000	.875	.792	.859

Peak Hour Analysis From 04:00 PM to 05:45 PM - Peak 1 of 1
 Peak Hour for Entire Intersection Begins at 04:00 PM



Peak Hour Analysis From 04:00 PM to 05:45 PM - Peak 1 of 1
 Peak Hour for Each Approach Begins at:

	04:00 PM				04:00 PM				04:00 PM				05:00 PM			
+0 mins.	0	23	0	23	0	0	0	0	0	49	2	51	18	0	9	27
+15 mins.	0	17	0	17	0	0	0	0	0	49	4	53	18	0	15	33
+30 mins.	0	22	1	23	0	0	0	0	0	25	1	26	23	0	10	33
+45 mins.	0	11	0	11	0	0	0	0	0	29	2	31	14	0	9	23
Total Volume	0	73	1	74	0	0	0	0	0	152	9	161	73	0	43	116
% App. Total	0	98.6	1.4	74	0	0	0	0	0	94.4	5.6	161	62.9	0	37.1	116
PHF	.000	.793	.250	.804	.000	.000	.000	.000	.000	.776	.563	.759	.793	.000	.717	.879

County of Imperial
 N/S: Orchard Road/SR-7
 E/W: I-8 Westbound Ramps
 Weather: Clear

File Name : 05_CIM_Orchard_I-8E AM
 Site Code : 04120461
 Start Date : 12/8/2020
 Page No : 1

Groups Printed- Total Volume

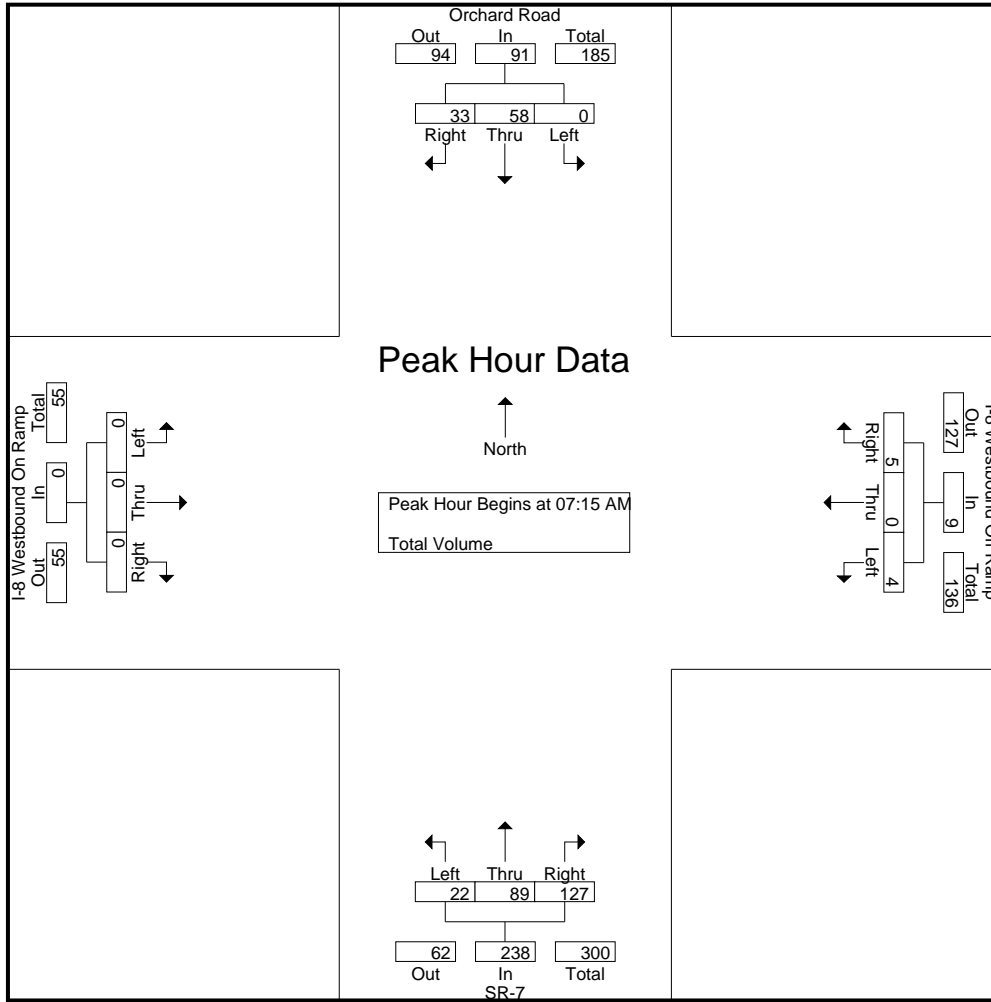
Start Time	Orchard Road Southbound				I-8 Westbound Off Ramp Westbound				SR-7 Northbound				I-8 Westbound On Ramp Eastbound				Int. Total
	Left	Thru	Right	App. Total	Left	Thru	Right	App. Total	Left	Thru	Right	App. Total	Left	Thru	Right	App. Total	
07:00 AM	0	10	7	17	0	0	1	1	4	26	28	58	0	0	0	0	76
07:15 AM	0	9	6	15	1	0	0	1	9	27	32	68	0	0	0	0	84
07:30 AM	0	19	10	29	1	0	1	2	3	20	25	48	0	0	0	0	79
07:45 AM	0	19	13	32	1	0	2	3	7	24	30	61	0	0	0	0	96
Total	0	57	36	93	3	0	4	7	23	97	115	235	0	0	0	0	335
08:00 AM	0	11	4	15	1	0	2	3	3	18	40	61	0	0	0	0	79
08:15 AM	0	16	9	25	0	0	0	0	0	21	22	43	0	0	0	0	68
08:30 AM	0	18	6	24	3	0	0	3	5	17	27	49	0	0	0	0	76
08:45 AM	0	15	11	26	0	0	2	2	6	21	28	55	0	0	0	0	83
Total	0	60	30	90	4	0	4	8	14	77	117	208	0	0	0	0	306
Grand Total	0	117	66	183	7	0	8	15	37	174	232	443	0	0	0	0	641
Apprch %	0	63.9	36.1		46.7	0	53.3		8.4	39.3	52.4		0	0	0		
Total %	0	18.3	10.3	28.5	1.1	0	1.2	2.3	5.8	27.1	36.2	69.1	0	0	0	0	

Start Time	Orchard Road Southbound				I-8 Westbound Off Ramp Westbound				SR-7 Northbound				I-8 Westbound On Ramp Eastbound				Int. Total
	Left	Thru	Right	App. Total	Left	Thru	Right	App. Total	Left	Thru	Right	App. Total	Left	Thru	Right	App. Total	
07:15 AM	0	9	6	15	1	0	0	1	9	27	32	68	0	0	0	0	84
07:30 AM	0	19	10	29	1	0	1	2	3	20	25	48	0	0	0	0	79
07:45 AM	0	19	13	32	1	0	2	3	7	24	30	61	0	0	0	0	96
08:00 AM	0	11	4	15	1	0	2	3	3	18	40	61	0	0	0	0	79
Total Volume	0	58	33	91	4	0	5	9	22	89	127	238	0	0	0	0	338
% App. Total	0	63.7	36.3		44.4	0	55.6		9.2	37.4	53.4		0	0	0		
PHF	.000	.763	.635	.711	1.00	.000	.625	.750	.611	.824	.794	.875	.000	.000	.000	.000	.880

Peak Hour Analysis From 07:00 AM to 08:45 AM - Peak 1 of 1
 Peak Hour for Entire Intersection Begins at 07:15 AM

County of Imperial
 N/S: Orchard Road/SR-7
 E/W: I-8 Westbound Ramps
 Weather: Clear

File Name : 05_CIM_Orchard_I-8E AM
 Site Code : 04120461
 Start Date : 12/8/2020
 Page No : 2



Peak Hour Analysis From 07:00 AM to 08:45 AM - Peak 1 of 1
 Peak Hour for Each Approach Begins at:

	07:30 AM				07:15 AM				07:15 AM				07:00 AM			
+0 mins.	0	19	10	29	1	0	0	1	9	27	32	68	0	0	0	0
+15 mins.	0	19	13	32	1	0	1	2	3	20	25	48	0	0	0	0
+30 mins.	0	11	4	15	1	0	2	3	7	24	30	61	0	0	0	0
+45 mins.	0	16	9	25	1	0	2	3	3	18	40	61	0	0	0	0
Total Volume	0	65	36	101	4	0	5	9	22	89	127	238	0	0	0	0
% App. Total	0	64.4	35.6		44.4	0	55.6		9.2	37.4	53.4		0	0	0	
PHF	.000	.855	.692	.789	1.000	.000	.625	.750	.611	.824	.794	.875	.000	.000	.000	.000

County of Imperial
 N/S: Orchard Road/SR-7
 E/W: I-8 Westbound Ramps
 Weather: Clear

File Name : 05_CIM_Orchard_I-8E PM
 Site Code : 04120461
 Start Date : 12/8/2020
 Page No : 1

Groups Printed- Total Volume

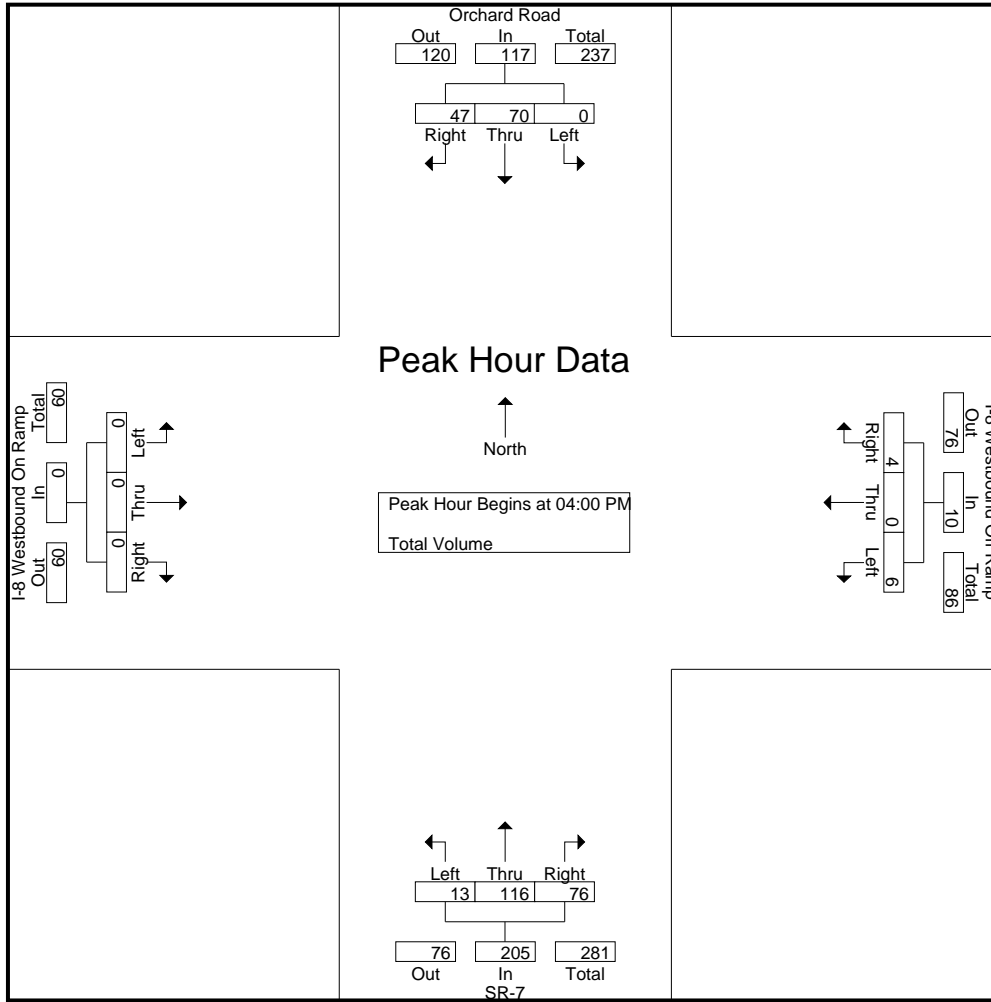
Start Time	Orchard Road Southbound				I-8 Westbound Off Ramp Westbound				SR-7 Northbound				I-8 Westbound On Ramp Eastbound				Int. Total
	Left	Thru	Right	App. Total	Left	Thru	Right	App. Total	Left	Thru	Right	App. Total	Left	Thru	Right	App. Total	
04:00 PM	0	21	11	32	3	0	1	4	4	24	26	54	0	0	0	0	90
04:15 PM	0	16	10	26	3	0	2	5	3	41	25	69	0	0	0	0	100
04:30 PM	0	21	11	32	0	0	0	0	1	28	8	37	0	0	0	0	69
04:45 PM	0	12	15	27	0	0	1	1	5	23	17	45	0	0	0	0	73
Total	0	70	47	117	6	0	4	10	13	116	76	205	0	0	0	0	332
05:00 PM	0	13	8	21	7	0	1	8	2	23	16	41	0	0	0	0	70
05:15 PM	0	16	4	20	2	0	0	2	1	24	12	37	0	0	0	0	59
05:30 PM	0	14	10	24	1	0	2	3	1	31	17	49	0	0	0	0	76
05:45 PM	0	7	7	14	5	0	1	6	0	21	14	35	0	0	0	0	55
Total	0	50	29	79	15	0	4	19	4	99	59	162	0	0	0	0	260
Grand Total	0	120	76	196	21	0	8	29	17	215	135	367	0	0	0	0	592
Apprch %	0	61.2	38.8		72.4	0	27.6		4.6	58.6	36.8		0	0	0		
Total %	0	20.3	12.8	33.1	3.5	0	1.4	4.9	2.9	36.3	22.8	62	0	0	0	0	

Start Time	Orchard Road Southbound				I-8 Westbound Off Ramp Westbound				SR-7 Northbound				I-8 Westbound On Ramp Eastbound				Int. Total
	Left	Thru	Right	App. Total	Left	Thru	Right	App. Total	Left	Thru	Right	App. Total	Left	Thru	Right	App. Total	
04:00 PM	0	21	11	32	3	0	1	4	4	24	26	54	0	0	0	0	90
04:15 PM	0	16	10	26	3	0	2	5	3	41	25	69	0	0	0	0	100
04:30 PM	0	21	11	32	0	0	0	0	1	28	8	37	0	0	0	0	69
04:45 PM	0	12	15	27	0	0	1	1	5	23	17	45	0	0	0	0	73
Total Volume	0	70	47	117	6	0	4	10	13	116	76	205	0	0	0	0	332
% App. Total	0	59.8	40.2		60	0	40		6.3	56.6	37.1		0	0	0		
PHF	.000	.833	.783	.914	.500	.000	.500	.500	.650	.707	.731	.743	.000	.000	.000	.000	.830

Peak Hour Analysis From 04:00 PM to 05:45 PM - Peak 1 of 1
 Peak Hour for Entire Intersection Begins at 04:00 PM

County of Imperial
 N/S: Orchard Road/SR-7
 E/W: I-8 Westbound Ramps
 Weather: Clear

File Name : 05_CIM_Orchard_I-8E PM
 Site Code : 04120461
 Start Date : 12/8/2020
 Page No : 2



Peak Hour Analysis From 04:00 PM to 05:45 PM - Peak 1 of 1
 Peak Hour for Each Approach Begins at:

	04:00 PM				05:00 PM				04:00 PM				04:00 PM			
+0 mins.	0	21	11	32	7	0	1	8	4	24	26	54	0	0	0	0
+15 mins.	0	16	10	26	2	0	0	2	3	41	25	69	0	0	0	0
+30 mins.	0	21	11	32	1	0	2	3	1	28	8	37	0	0	0	0
+45 mins.	0	12	15	27	5	0	1	6	5	23	17	45	0	0	0	0
Total Volume	0	70	47	117	15	0	4	19	13	116	76	205	0	0	0	0
% App. Total	0	59.8	40.2		78.9	0	21.1		6.3	56.6	37.1		0	0	0	
PHF	.000	.833	.783	.914	.536	.000	.500	.594	.650	.707	.731	.743	.000	.000	.000	.000

APPENDIX B : EXISTING YEAR CONDITIONS ANALYSIS WORKSHEETS

Intersection						
Int Delay, s/veh	0					
Movement	EBT	EBR	WBL	WBT	NBL	NBR
Lane Configurations						
Traffic Vol, veh/h	61	0	0	54	0	0
Future Vol, veh/h	61	0	0	54	0	0
Conflicting Peds, #/hr	0	0	0	0	0	0
Sign Control	Free	Free	Free	Free	Stop	Stop
RT Channelized	-	None	-	None	-	None
Storage Length	-	-	-	-	0	-
Veh in Median Storage, #	0	-	-	0	0	-
Grade, %	0	-	-	0	0	-
Peak Hour Factor	92	92	92	92	92	92
Heavy Vehicles, %	2	2	2	2	2	2
Mvmt Flow	66	0	0	59	0	0

Major/Minor	Major1	Major2	Minor1		
Conflicting Flow All	0	0	66	0	125 66
Stage 1	-	-	-	-	66 -
Stage 2	-	-	-	-	59 -
Critical Hdwy	-	-	4.12	-	6.42 6.22
Critical Hdwy Stg 1	-	-	-	-	5.42 -
Critical Hdwy Stg 2	-	-	-	-	5.42 -
Follow-up Hdwy	-	-	2.218	-	3.518 3.318
Pot Cap-1 Maneuver	-	-	1536	-	870 998
Stage 1	-	-	-	-	957 -
Stage 2	-	-	-	-	964 -
Platoon blocked, %	-	-	-	-	-
Mov Cap-1 Maneuver	-	-	1536	-	870 998
Mov Cap-2 Maneuver	-	-	-	-	870 -
Stage 1	-	-	-	-	957 -
Stage 2	-	-	-	-	964 -

Approach	EB	WB	NB
HCM Control Delay, s	0	0	0
HCM LOS			A

Minor Lane/Major Mvmt	NBLn1	EBT	EBR	WBL	WBT
Capacity (veh/h)	-	-	-	1536	-
HCM Lane V/C Ratio	-	-	-	-	-
HCM Control Delay (s)	0	-	-	0	-
HCM Lane LOS	A	-	-	A	-
HCM 95th %tile Q(veh)	-	-	-	0	-

Intersection						
Int Delay, s/veh	0					
Movement	EBT	EBR	WBL	WBT	NBL	NBR
Lane Configurations						
Traffic Vol, veh/h	66	0	0	82	0	0
Future Vol, veh/h	66	0	0	82	0	0
Conflicting Peds, #/hr	0	0	0	0	0	0
Sign Control	Free	Free	Free	Free	Stop	Stop
RT Channelized	-	None	-	None	-	None
Storage Length	-	-	-	-	0	-
Veh in Median Storage, #	0	-	-	0	0	-
Grade, %	0	-	-	0	0	-
Peak Hour Factor	92	92	92	92	92	92
Heavy Vehicles, %	2	2	2	2	2	2
Mvmt Flow	72	0	0	89	0	0

Major/Minor	Major1	Major2	Minor1	Minor2	Minor3
Conflicting Flow All	0	0	72	0	161
Stage 1	-	-	-	-	72
Stage 2	-	-	-	-	89
Critical Hdwy	-	-	4.12	-	6.42
Critical Hdwy Stg 1	-	-	-	-	5.42
Critical Hdwy Stg 2	-	-	-	-	5.42
Follow-up Hdwy	-	-	2.218	-	3.518
Pot Cap-1 Maneuver	-	-	1528	-	830
Stage 1	-	-	-	-	951
Stage 2	-	-	-	-	934
Platoon blocked, %	-	-	-	-	-
Mov Cap-1 Maneuver	-	-	1528	-	830
Mov Cap-2 Maneuver	-	-	-	-	830
Stage 1	-	-	-	-	951
Stage 2	-	-	-	-	934

Approach	EB	WB	NB
HCM Control Delay, s	0	0	0
HCM LOS			A

Minor Lane/Major Mvmt	NBLn1	EBT	EBR	WBL	WBT
Capacity (veh/h)	-	-	-	1528	-
HCM Lane V/C Ratio	-	-	-	-	-
HCM Control Delay (s)	0	-	-	0	-
HCM Lane LOS	A	-	-	A	-
HCM 95th %tile Q(veh)	-	-	-	0	-

Intersection						
Int Delay, s/veh	1.3					
Movement	EBL	EBT	WBT	WBR	SBL	SBR
Lane Configurations	↘	↑	↗		↘	↗
Traffic Vol, veh/h	10	61	54	7	6	7
Future Vol, veh/h	10	61	54	7	6	7
Conflicting Peds, #/hr	0	0	0	0	0	0
Sign Control	Free	Free	Free	Free	Stop	Stop
RT Channelized	-	None	-	None	-	None
Storage Length	0	-	-	-	0	0
Veh in Median Storage, #	-	0	0	-	0	-
Grade, %	-	0	0	-	0	-
Peak Hour Factor	92	92	92	92	92	92
Heavy Vehicles, %	2	2	2	2	2	2
Mvmt Flow	11	66	59	8	7	8

Major/Minor	Major1	Major2	Minor2		
Conflicting Flow All	67	0	-	0	151
Stage 1	-	-	-	-	63
Stage 2	-	-	-	-	88
Critical Hdwy	4.12	-	-	-	6.42
Critical Hdwy Stg 1	-	-	-	-	5.42
Critical Hdwy Stg 2	-	-	-	-	5.42
Follow-up Hdwy	2.218	-	-	-	3.518
Pot Cap-1 Maneuver	1535	-	-	-	841
Stage 1	-	-	-	-	960
Stage 2	-	-	-	-	935
Platoon blocked, %		-	-	-	
Mov Cap-1 Maneuver	1535	-	-	-	835
Mov Cap-2 Maneuver	-	-	-	-	835
Stage 1	-	-	-	-	953
Stage 2	-	-	-	-	935

Approach	EB	WB	SB
HCM Control Delay, s	1	0	8.9
HCM LOS			A

Minor Lane/Major Mvmt	EBL	EBT	WBT	WBR	SBLn1	SBLn2
Capacity (veh/h)	1535	-	-	-	835	1002
HCM Lane V/C Ratio	0.007	-	-	-	0.008	0.008
HCM Control Delay (s)	7.4	-	-	-	9.3	8.6
HCM Lane LOS	A	-	-	-	A	A
HCM 95th %tile Q(veh)	0	-	-	-	0	0

Intersection

Int Delay, s/veh 1.1

Movement	EBL	EBT	WBT	WBR	SBL	SBR
Lane Configurations	↘	↑	↗		↘	↗
Traffic Vol, veh/h	5	66	82	10	2	17
Future Vol, veh/h	5	66	82	10	2	17
Conflicting Peds, #/hr	0	0	0	0	0	0
Sign Control	Free	Free	Free	Free	Stop	Stop
RT Channelized	-	None	-	None	-	None
Storage Length	0	-	-	-	0	0
Veh in Median Storage, #	-	0	0	-	0	-
Grade, %	-	0	0	-	0	-
Peak Hour Factor	92	92	92	92	92	92
Heavy Vehicles, %	2	2	2	2	2	2
Mvmt Flow	5	72	89	11	2	18

Major/Minor	Major1	Major2	Minor2
Conflicting Flow All	100	0	0
Stage 1	-	-	95
Stage 2	-	-	82
Critical Hdwy	4.12	-	6.42
Critical Hdwy Stg 1	-	-	5.42
Critical Hdwy Stg 2	-	-	5.42
Follow-up Hdwy	2.218	-	3.518
Pot Cap-1 Maneuver	1493	-	813
Stage 1	-	-	929
Stage 2	-	-	941
Platoon blocked, %	-	-	-
Mov Cap-1 Maneuver	1493	-	811
Mov Cap-2 Maneuver	-	-	811
Stage 1	-	-	926
Stage 2	-	-	941

Approach	EB	WB	SB
HCM Control Delay, s	0.5	0	8.9
HCM LOS			A

Minor Lane/Major Mvmt	EBL	EBT	WBT	WBR	SBLn1	SBLn2
Capacity (veh/h)	1493	-	-	-	811	962
HCM Lane V/C Ratio	0.004	-	-	-	0.003	0.019
HCM Control Delay (s)	7.4	-	-	-	9.5	8.8
HCM Lane LOS	A	-	-	-	A	A
HCM 95th %tile Q(veh)	0	-	-	-	0	0.1

HCM 2010 Signalized Intersection Capacity Analysis
 12: CA 7 & CA 98

01/07/2021

Movement	EBL	EBT	EBR	WBL	WBT	WBR	NBL	NBT	NBR	SBL	SBT	SBR
Lane Configurations												
Traffic Volume (veh/h)	21	25	106	27	26	8	53	176	31	4	123	40
Future Volume (veh/h)	21	25	106	27	26	8	53	176	31	4	123	40
Number	7	4	14	3	8	18	5	2	12	1	6	16
Initial Q, veh	0	0	0	0	0	0	0	0	0	0	0	0
Ped-Bike Adj (A_pbT)	1.00		1.00	1.00		1.00	1.00		1.00	1.00		1.00
Parking Bus Adj	1.00	1.00	1.00	1.00	1.00	1.00	1.00	1.00	1.00	1.00	1.00	1.00
Adj Sat Flow, veh/h/ln	1863	1863	1863	1863	1863	1863	1863	1863	1863	1863	1863	1863
Adj Flow Rate, veh/h	23	27	115	29	28	9	58	191	34	4	134	43
Adj No. of Lanes	1	1	2	1	1	1	2	2	1	1	2	1
Peak Hour Factor	0.92	0.92	0.92	0.92	0.92	0.92	0.92	0.92	0.92	0.92	0.92	0.92
Percent Heavy Veh, %	2	2	2	2	2	2	2	2	2	2	2	2
Opposing Right Turn Influence	Yes			Yes			Yes			Yes		
Cap, veh/h	694	745	1115	646	745	633	1198	1416	633	581	1416	633
HCM Platoon Ratio	1.00	1.00	1.00	1.00	1.00	1.00	1.00	1.00	1.00	1.00	1.00	1.00
Prop Arrive On Green	0.40	0.40	0.40	0.40	0.40	0.40	0.40	0.40	0.40	0.40	0.40	0.40
Ln Grp Delay, s/veh	8.6	8.3	8.6	8.7	8.3	8.2	9.0	8.8	8.4	9.1	8.6	8.5
Ln Grp LOS	A	A	A	A	A	A	A	A	A	A	A	A
Approach Vol, veh/h		165			66			283			181	
Approach Delay, s/veh		8.6			8.5			8.8			8.6	
Approach LOS		A			A			A			A	
Timer:		1	2	3	4	5	6	7	8			
Assigned Phs			2		4		6		8			
Case No			5.0		5.0		5.0		5.0			
Phs Duration (G+Y+Rc), s			22.5		22.5		22.5		22.5			
Change Period (Y+Rc), s			4.5		4.5		4.5		4.5			
Max Green (Gmax), s			18.0		18.0		18.0		18.0			
Max Allow Headway (MAH), s			4.9		4.2		4.9		4.6			
Max Q Clear (g_c+I1), s			3.8		3.2		3.6		3.1			
Green Ext Time (g_e), s			1.3		0.5		0.7		0.2			
Prob of Phs Call (p_c)			1.00		1.00		1.00		1.00			
Prob of Max Out (p_x)			0.00		0.00		0.00		0.00			
Left-Turn Movement Data												
Assigned Mvmt			5		7		1		3			
Mvmt Sat Flow, veh/h			2333		1365		1151		1241			
Through Movement Data												
Assigned Mvmt			2		4		6		8			
Mvmt Sat Flow, veh/h			3539		1863		3539		1863			
Right-Turn Movement Data												
Assigned Mvmt			12		14		16		18			
Mvmt Sat Flow, veh/h			1583		2787		1583		1583			
Left Lane Group Data												
Assigned Mvmt		0	5	0	7	0	1	0	3			
Lane Assignment												

HCM 2010 Signalized Intersection Capacity Analysis
 12: CA 7 & CA 98

01/07/2021

Lanes in Grp	0	2	0	1	0	1	0	1
Grp Vol (v), veh/h	0	58	0	23	0	4	0	29
Grp Sat Flow (s), veh/h/ln	0	1166	0	1365	0	1151	0	1241
Q Serve Time (g_s), s	0.0	0.7	0.0	0.5	0.0	0.1	0.0	0.7
Cycle Q Clear Time (g_c), s	0.0	1.8	0.0	0.9	0.0	1.6	0.0	1.1
Perm LT Sat Flow (s_l), veh/h/ln	0	1166	0	1365	0	1151	0	1241
Shared LT Sat Flow (s_sh), veh/h/ln	0	0	0	0	0	0	0	0
Perm LT Eff Green (g_p), s	0.0	18.0	0.0	18.0	0.0	18.0	0.0	18.0
Perm LT Serve Time (g_u), s	0.0	16.9	0.0	17.6	0.0	16.5	0.0	17.6
Perm LT Q Serve Time (g_ps), s	0.0	0.7	0.0	0.5	0.0	0.1	0.0	0.7
Time to First Blk (g_f), s	0.0	0.0	0.0	0.0	0.0	0.0	0.0	0.0
Serve Time pre Blk (g_fs), s	0.0	0.0	0.0	0.0	0.0	0.0	0.0	0.0
Prop LT Inside Lane (P_L)	0.00	1.00	0.00	1.00	0.00	1.00	0.00	1.00
Lane Grp Cap (c), veh/h	0	1198	0	694	0	581	0	646
V/C Ratio (X)	0.00	0.05	0.00	0.03	0.00	0.01	0.00	0.04
Avail Cap (c_a), veh/h	0	1198	0	694	0	581	0	646
Upstream Filter (I)	0.00	1.00	0.00	1.00	0.00	1.00	0.00	1.00
Uniform Delay (d1), s/veh	0.0	9.0	0.0	8.5	0.0	9.1	0.0	8.5
Incr Delay (d2), s/veh	0.0	0.1	0.0	0.1	0.0	0.0	0.0	0.1
Initial Q Delay (d3), s/veh	0.0	0.0	0.0	0.0	0.0	0.0	0.0	0.0
Control Delay (d), s/veh	0.0	9.0	0.0	8.6	0.0	9.1	0.0	8.7
1st-Term Q (Q1), veh/ln	0.0	0.2	0.0	0.2	0.0	0.0	0.0	0.2
2nd-Term Q (Q2), veh/ln	0.0	0.0	0.0	0.0	0.0	0.0	0.0	0.0
3rd-Term Q (Q3), veh/ln	0.0	0.0	0.0	0.0	0.0	0.0	0.0	0.0
%ile Back of Q Factor (f_B%)	0.00	1.00	0.00	1.00	0.00	1.00	0.00	1.00
%ile Back of Q (50%), veh/ln	0.0	0.2	0.0	0.2	0.0	0.0	0.0	0.2
%ile Storage Ratio (RQ%)	0.00	0.00	0.00	0.00	0.00	0.00	0.00	0.00
Initial Q (Qb), veh	0.0	0.0	0.0	0.0	0.0	0.0	0.0	0.0
Final (Residual) Q (Qe), veh	0.0	0.0	0.0	0.0	0.0	0.0	0.0	0.0
Sat Delay (ds), s/veh	0.0	0.0	0.0	0.0	0.0	0.0	0.0	0.0
Sat Q (Qs), veh	0.0	0.0	0.0	0.0	0.0	0.0	0.0	0.0
Sat Cap (cs), veh/h	0	0	0	0	0	0	0	0
Initial Q Clear Time (tc), h	0.0	0.0	0.0	0.0	0.0	0.0	0.0	0.0
Middle Lane Group Data								
Assigned Mvmt	0	2	0	4	0	6	0	8
Lane Assignment		T		T		T		T
Lanes in Grp	0	2	0	1	0	2	0	1
Grp Vol (v), veh/h	0	191	0	27	0	134	0	28
Grp Sat Flow (s), veh/h/ln	0	1770	0	1863	0	1770	0	1863
Q Serve Time (g_s), s	0.0	1.5	0.0	0.4	0.0	1.1	0.0	0.4
Cycle Q Clear Time (g_c), s	0.0	1.5	0.0	0.4	0.0	1.1	0.0	0.4
Lane Grp Cap (c), veh/h	0	1416	0	745	0	1416	0	745
V/C Ratio (X)	0.00	0.13	0.00	0.04	0.00	0.09	0.00	0.04
Avail Cap (c_a), veh/h	0	1416	0	745	0	1416	0	745
Upstream Filter (I)	0.00	1.00	0.00	1.00	0.00	1.00	0.00	1.00
Uniform Delay (d1), s/veh	0.0	8.6	0.0	8.2	0.0	8.4	0.0	8.2
Incr Delay (d2), s/veh	0.0	0.2	0.0	0.1	0.0	0.1	0.0	0.1
Initial Q Delay (d3), s/veh	0.0	0.0	0.0	0.0	0.0	0.0	0.0	0.0
Control Delay (d), s/veh	0.0	8.8	0.0	8.3	0.0	8.6	0.0	8.3
1st-Term Q (Q1), veh/ln	0.0	0.7	0.0	0.2	0.0	0.5	0.0	0.2

Baseline

Synchro 10 Report
 Page 2

PC ORIGINAL PKG

HCM 2010 Signalized Intersection Capacity Analysis
 12: CA 7 & CA 98

01/07/2021

2nd-Term Q (Q2), veh/ln	0.0	0.0	0.0	0.0	0.0	0.0	0.0	0.0
3rd-Term Q (Q3), veh/ln	0.0	0.0	0.0	0.0	0.0	0.0	0.0	0.0
%ile Back of Q Factor (f_B%)	0.00	1.00	0.00	1.00	0.00	1.00	0.00	1.00
%ile Back of Q (50%), veh/ln	0.0	0.8	0.0	0.2	0.0	0.5	0.0	0.2
%ile Storage Ratio (RQ%)	0.00	0.01	0.00	0.00	0.00	0.02	0.00	0.00
Initial Q (Qb), veh	0.0	0.0	0.0	0.0	0.0	0.0	0.0	0.0
Final (Residual) Q (Qe), veh	0.0	0.0	0.0	0.0	0.0	0.0	0.0	0.0
Sat Delay (ds), s/veh	0.0	0.0	0.0	0.0	0.0	0.0	0.0	0.0
Sat Q (Qs), veh	0.0	0.0	0.0	0.0	0.0	0.0	0.0	0.0
Sat Cap (cs), veh/h	0	0	0	0	0	0	0	0
Initial Q Clear Time (tc), h	0.0	0.0	0.0	0.0	0.0	0.0	0.0	0.0

Right Lane Group Data

























Assigned Mvmt	0	12	0	14	0	16	0	18
Lane Assignment		R		R		R		R
Lanes in Grp	0	1	0	2	0	1	0	1
Grp Vol (v), veh/h	0	34	0	115	0	43	0	9
Grp Sat Flow (s), veh/h/ln	0	1583	0	1393	0	1583	0	1583
Q Serve Time (g_s), s	0.0	0.6	0.0	1.2	0.0	0.8	0.0	0.2
Cycle Q Clear Time (g_c), s	0.0	0.6	0.0	1.2	0.0	0.8	0.0	0.2
Prot RT Sat Flow (s_R), veh/h/ln	0.0	0.0	0.0	0.0	0.0	0.0	0.0	0.0
Prot RT Eff Green (g_R), s	0.0	0.0	0.0	0.0	0.0	0.0	0.0	0.0
Prop RT Outside Lane (P_R)	0.00	1.00	0.00	1.00	0.00	1.00	0.00	1.00
Lane Grp Cap (c), veh/h	0	633	0	1115	0	633	0	633
V/C Ratio (X)	0.00	0.05	0.00	0.10	0.00	0.07	0.00	0.01
Avail Cap (c_a), veh/h	0	633	0	1115	0	633	0	633
Upstream Filter (I)	0.00	1.00	0.00	1.00	0.00	1.00	0.00	1.00
Uniform Delay (d1), s/veh	0.0	8.3	0.0	8.4	0.0	8.3	0.0	8.1
Incr Delay (d2), s/veh	0.0	0.2	0.0	0.2	0.0	0.2	0.0	0.0
Initial Q Delay (d3), s/veh	0.0	0.0	0.0	0.0	0.0	0.0	0.0	0.0
Control Delay (d), s/veh	0.0	8.4	0.0	8.6	0.0	8.5	0.0	8.2
1st-Term Q (Q1), veh/ln	0.0	0.3	0.0	0.4	0.0	0.3	0.0	0.1
2nd-Term Q (Q2), veh/ln	0.0	0.0	0.0	0.0	0.0	0.0	0.0	0.0
3rd-Term Q (Q3), veh/ln	0.0	0.0	0.0	0.0	0.0	0.0	0.0	0.0
%ile Back of Q Factor (f_B%)	0.00	1.00	0.00	1.00	0.00	1.00	0.00	1.00
%ile Back of Q (50%), veh/ln	0.0	0.3	0.0	0.5	0.0	0.4	0.0	0.1
%ile Storage Ratio (RQ%)	0.00	0.00	0.00	0.00	0.00	0.01	0.00	0.00
Initial Q (Qb), veh	0.0	0.0	0.0	0.0	0.0	0.0	0.0	0.0
Final (Residual) Q (Qe), veh	0.0	0.0	0.0	0.0	0.0	0.0	0.0	0.0
Sat Delay (ds), s/veh	0.0	0.0	0.0	0.0	0.0	0.0	0.0	0.0
Sat Q (Qs), veh	0.0	0.0	0.0	0.0	0.0	0.0	0.0	0.0
Sat Cap (cs), veh/h	0	0	0	0	0	0	0	0
Initial Q Clear Time (tc), h	0.0	0.0	0.0	0.0	0.0	0.0	0.0	0.0

Intersection Summary

HCM 2010 Ctrl Delay	8.6
HCM 2010 LOS	A

HCM 2010 Signalized Intersection Capacity Analysis
 12: CA 7 & CA 98

12/15/2021

												
Movement	EBL	EBT	EBR	WBL	WBT	WBR	NBL	NBT	NBR	SBL	SBT	SBR
Lane Configurations												
Traffic Volume (veh/h)	36	52	98	14	103	9	94	106	17	0	64	62
Future Volume (veh/h)	36	52	98	14	103	9	94	106	17	0	64	62
Number	7	4	14	3	8	18	5	2	12	1	6	16
Initial Q, veh	0	0	0	0	0	0	0	0	0	0	0	0
Ped-Bike Adj (A_pbT)	1.00		1.00	1.00		1.00	1.00		1.00	1.00		1.00
Parking Bus Adj	1.00	1.00	1.00	1.00	1.00	1.00	1.00	1.00	1.00	1.00	1.00	1.00
Adj Sat Flow, veh/h/ln	1863	1863	1863	1863	1863	1863	1863	1863	1863	1863	1863	1863
Adj Flow Rate, veh/h	39	57	107	15	112	10	102	115	18	0	70	67
Adj No. of Lanes	1	1	2	1	1	1	2	2	1	1	2	1
Peak Hour Factor	0.92	0.92	0.92	0.92	0.92	0.92	0.92	0.92	0.92	0.92	0.92	0.92
Percent Heavy Veh, %	2	2	2	2	2	2	2	2	2	2	2	2
Opposing Right Turn Influence	Yes			Yes			Yes			Yes		
Cap, veh/h	617	745	1115	624	745	633	1258	1416	633	160	1416	633
HCM Platoon Ratio	1.00	1.00	1.00	1.00	1.00	1.00	1.00	1.00	1.00	1.00	1.00	1.00
Prop Arrive On Green	0.40	0.40	0.40	0.40	0.40	0.40	0.40	0.40	0.40	0.00	0.40	0.40
Ln Grp Delay, s/veh	9.7	8.6	8.6	8.8	9.0	8.2	8.9	8.5	8.3	0.0	8.3	8.8
Ln Grp LOS	A	A	A	A	A	A	A	A	A		A	A
Approach Vol, veh/h		203			137			235			137	
Approach Delay, s/veh		8.8			9.0			8.7			8.6	
Approach LOS		A			A			A			A	
Timer:		1	2	3	4	5	6	7	8			
Assigned Phs			2		4		6		8			
Case No			5.0		5.0		5.0		5.0			
Phs Duration (G+Y+Rc), s			22.5		22.5		22.5		22.5			
Change Period (Y+Rc), s			4.5		4.5		4.5		4.5			
Max Green (Gmax), s			18.0		18.0		18.0		18.0			
Max Allow Headway (MAH), s			4.7		4.4		4.7		5.0			
Max Q Clear (g_c+I1), s			3.8		4.6		3.2		3.7			
Green Ext Time (g_e), s			0.9		0.6		0.5		0.5			
Prob of Phs Call (p_c)			1.00		1.00		1.00		1.00			
Prob of Max Out (p_x)			0.00		0.00		0.00		0.00			
Left-Turn Movement Data												
Assigned Mvmt			5		7		1		3			
Mvmt Sat Flow, veh/h			2419		1264		1252		1217			
Through Movement Data												
Assigned Mvmt			2		4		6		8			
Mvmt Sat Flow, veh/h			3539		1863		3539		1863			
Right-Turn Movement Data												
Assigned Mvmt			12		14		16		18			
Mvmt Sat Flow, veh/h			1583		2787		1583		1583			
Left Lane Group Data												
Assigned Mvmt		0	5	0	7	0	1	0	3			
Lane Assignment												

HCM 2010 Signalized Intersection Capacity Analysis
 12: CA 7 & CA 98

12/15/2021

Lanes in Grp	0	2	0	1	0	1	0	1
Grp Vol (v), veh/h	0	102	0	39	0	0	0	15
Grp Sat Flow (s), veh/h/ln	0	1210	0	1264	0	1252	0	1217
Q Serve Time (g_s), s	0.0	1.2	0.0	0.9	0.0	0.0	0.0	0.3
Cycle Q Clear Time (g_c), s	0.0	1.8	0.0	2.6	0.0	0.0	0.0	1.2
Perm LT Sat Flow (s_l), veh/h/ln	0	1210	0	1264	0	1252	0	1217
Shared LT Sat Flow (s_sh), veh/h/ln	0	0	0	0	0	0	0	0
Perm LT Eff Green (g_p), s	0.0	18.0	0.0	18.0	0.0	0.0	0.0	18.0
Perm LT Serve Time (g_u), s	0.0	17.5	0.0	16.3	0.0	0.0	0.0	17.1
Perm LT Q Serve Time (g_ps), s	0.0	1.2	0.0	0.9	0.0	0.0	0.0	0.3
Time to First Blk (g_f), s	0.0	0.0	0.0	0.0	0.0	0.0	0.0	0.0
Serve Time pre Blk (g_fs), s	0.0	0.0	0.0	0.0	0.0	0.0	0.0	0.0
Prop LT Inside Lane (P_L)	0.00	1.00	0.00	1.00	0.00	1.00	0.00	1.00
Lane Grp Cap (c), veh/h	0	1258	0	617	0	160	0	624
V/C Ratio (X)	0.00	0.08	0.00	0.06	0.00	0.00	0.00	0.02
Avail Cap (c_a), veh/h	0	1258	0	617	0	160	0	624
Upstream Filter (I)	0.00	1.00	0.00	1.00	0.00	0.00	0.00	1.00
Uniform Delay (d1), s/veh	0.0	8.8	0.0	9.5	0.0	0.0	0.0	8.7
Incr Delay (d2), s/veh	0.0	0.1	0.0	0.2	0.0	0.0	0.0	0.1
Initial Q Delay (d3), s/veh	0.0	0.0	0.0	0.0	0.0	0.0	0.0	0.0
Control Delay (d), s/veh	0.0	8.9	0.0	9.7	0.0	0.0	0.0	8.8
1st-Term Q (Q1), veh/ln	0.0	0.4	0.0	0.3	0.0	0.0	0.0	0.1
2nd-Term Q (Q2), veh/ln	0.0	0.0	0.0	0.0	0.0	0.0	0.0	0.0
3rd-Term Q (Q3), veh/ln	0.0	0.0	0.0	0.0	0.0	0.0	0.0	0.0
%ile Back of Q Factor (f_B%)	0.00	1.00	0.00	1.00	0.00	1.00	0.00	1.00
%ile Back of Q (50%), veh/ln	0.0	0.4	0.0	0.3	0.0	0.0	0.0	0.1
%ile Storage Ratio (RQ%)	0.00	0.01	0.00	0.00	0.00	0.00	0.00	0.00
Initial Q (Qb), veh	0.0	0.0	0.0	0.0	0.0	0.0	0.0	0.0
Final (Residual) Q (Qe), veh	0.0	0.0	0.0	0.0	0.0	0.0	0.0	0.0
Sat Delay (ds), s/veh	0.0	0.0	0.0	0.0	0.0	0.0	0.0	0.0
Sat Q (Qs), veh	0.0	0.0	0.0	0.0	0.0	0.0	0.0	0.0
Sat Cap (cs), veh/h	0	0	0	0	0	0	0	0
Initial Q Clear Time (tc), h	0.0	0.0	0.0	0.0	0.0	0.0	0.0	0.0
Middle Lane Group Data								
Assigned Mvmt	0	2	0	4	0	6	0	8
Lane Assignment		T		T		T		T
Lanes in Grp	0	2	0	1	0	2	0	1
Grp Vol (v), veh/h	0	115	0	57	0	70	0	112
Grp Sat Flow (s), veh/h/ln	0	1770	0	1863	0	1770	0	1863
Q Serve Time (g_s), s	0.0	0.9	0.0	0.9	0.0	0.5	0.0	1.7
Cycle Q Clear Time (g_c), s	0.0	0.9	0.0	0.9	0.0	0.5	0.0	1.7
Lane Grp Cap (c), veh/h	0	1416	0	745	0	1416	0	745
V/C Ratio (X)	0.00	0.08	0.00	0.08	0.00	0.05	0.00	0.15
Avail Cap (c_a), veh/h	0	1416	0	745	0	1416	0	745
Upstream Filter (I)	0.00	1.00	0.00	1.00	0.00	1.00	0.00	1.00
Uniform Delay (d1), s/veh	0.0	8.4	0.0	8.4	0.0	8.3	0.0	8.6
Incr Delay (d2), s/veh	0.0	0.1	0.0	0.2	0.0	0.1	0.0	0.4
Initial Q Delay (d3), s/veh	0.0	0.0	0.0	0.0	0.0	0.0	0.0	0.0
Control Delay (d), s/veh	0.0	8.5	0.0	8.6	0.0	8.3	0.0	9.0
1st-Term Q (Q1), veh/ln	0.0	0.4	0.0	0.4	0.0	0.3	0.0	0.9

Baseline

Synchro 10 Report
 Page 2

PC ORIGINAL PKG

HCM 2010 Signalized Intersection Capacity Analysis
 12: CA 7 & CA 98

12/15/2021

2nd-Term Q (Q2), veh/ln	0.0	0.0	0.0	0.0	0.0	0.0	0.0	0.1
3rd-Term Q (Q3), veh/ln	0.0	0.0	0.0	0.0	0.0	0.0	0.0	0.0
%ile Back of Q Factor (f_B%)	0.00	1.00	0.00	1.00	0.00	1.00	0.00	1.00
%ile Back of Q (50%), veh/ln	0.0	0.5	0.0	0.5	0.0	0.3	0.0	1.0
%ile Storage Ratio (RQ%)	0.00	0.01	0.00	0.00	0.00	0.01	0.00	0.00
Initial Q (Qb), veh	0.0	0.0	0.0	0.0	0.0	0.0	0.0	0.0
Final (Residual) Q (Qe), veh	0.0	0.0	0.0	0.0	0.0	0.0	0.0	0.0
Sat Delay (ds), s/veh	0.0	0.0	0.0	0.0	0.0	0.0	0.0	0.0
Sat Q (Qs), veh	0.0	0.0	0.0	0.0	0.0	0.0	0.0	0.0
Sat Cap (cs), veh/h	0	0	0	0	0	0	0	0
Initial Q Clear Time (tc), h	0.0	0.0	0.0	0.0	0.0	0.0	0.0	0.0

Right Lane Group Data

Assigned Mvmt	0	12	0	14	0	16	0	18
Lane Assignment		R		R		R		R
Lanes in Grp	0	1	0	2	0	1	0	1
Grp Vol (v), veh/h	0	18	0	107	0	67	0	10
Grp Sat Flow (s), veh/h/ln	0	1583	0	1393	0	1583	0	1583
Q Serve Time (g_s), s	0.0	0.3	0.0	1.1	0.0	1.2	0.0	0.2
Cycle Q Clear Time (g_c), s	0.0	0.3	0.0	1.1	0.0	1.2	0.0	0.2
Prot RT Sat Flow (s_R), veh/h/ln	0.0	0.0	0.0	0.0	0.0	0.0	0.0	0.0
Prot RT Eff Green (g_R), s	0.0	0.0	0.0	0.0	0.0	0.0	0.0	0.0
Prop RT Outside Lane (P_R)	0.00	1.00	0.00	1.00	0.00	1.00	0.00	1.00
Lane Grp Cap (c), veh/h	0	633	0	1115	0	633	0	633
V/C Ratio (X)	0.00	0.03	0.00	0.10	0.00	0.11	0.00	0.02
Avail Cap (c_a), veh/h	0	633	0	1115	0	633	0	633
Upstream Filter (I)	0.00	1.00	0.00	1.00	0.00	1.00	0.00	1.00
Uniform Delay (d1), s/veh	0.0	8.2	0.0	8.4	0.0	8.5	0.0	8.2
Incr Delay (d2), s/veh	0.0	0.1	0.0	0.2	0.0	0.3	0.0	0.0
Initial Q Delay (d3), s/veh	0.0	0.0	0.0	0.0	0.0	0.0	0.0	0.0
Control Delay (d), s/veh	0.0	8.3	0.0	8.6	0.0	8.8	0.0	8.2
1st-Term Q (Q1), veh/ln	0.0	0.1	0.0	0.4	0.0	0.5	0.0	0.1
2nd-Term Q (Q2), veh/ln	0.0	0.0	0.0	0.0	0.0	0.1	0.0	0.0
3rd-Term Q (Q3), veh/ln	0.0	0.0	0.0	0.0	0.0	0.0	0.0	0.0
%ile Back of Q Factor (f_B%)	0.00	1.00	0.00	1.00	0.00	1.00	0.00	1.00
%ile Back of Q (50%), veh/ln	0.0	0.1	0.0	0.4	0.0	0.6	0.0	0.1
%ile Storage Ratio (RQ%)	0.00	0.00	0.00	0.00	0.00	0.02	0.00	0.00
Initial Q (Qb), veh	0.0	0.0	0.0	0.0	0.0	0.0	0.0	0.0
Final (Residual) Q (Qe), veh	0.0	0.0	0.0	0.0	0.0	0.0	0.0	0.0
Sat Delay (ds), s/veh	0.0	0.0	0.0	0.0	0.0	0.0	0.0	0.0
Sat Q (Qs), veh	0.0	0.0	0.0	0.0	0.0	0.0	0.0	0.0
Sat Cap (cs), veh/h	0	0	0	0	0	0	0	0
Initial Q Clear Time (tc), h	0.0	0.0	0.0	0.0	0.0	0.0	0.0	0.0

Intersection Summary

HCM 2010 Ctrl Delay	8.7
HCM 2010 LOS	A

Intersection

Int Delay, s/veh 1

Movement	EBL	EBT	EBR	WBL	WBT	WBR	NBL	NBT	NBR	SBL	SBT	SBR
Lane Configurations		↕	↕		↕	↕	↕	↕↕	↕	↕	↕↕	↕
Traffic Vol, veh/h	0	3	5	3	2	13	15	196	3	8	158	10
Future Vol, veh/h	0	3	5	3	2	13	15	196	3	8	158	10
Conflicting Peds, #/hr	0	0	0	0	0	0	0	0	0	0	0	0
Sign Control	Stop	Stop	Stop	Stop	Stop	Stop	Free	Free	Free	Free	Free	Free
RT Channelized	-	-	None	-	-	None	-	-	None	-	-	None
Storage Length	-	-	0	-	-	0	0	-	0	0	-	0
Veh in Median Storage, #	-	0	-	-	0	-	-	0	-	-	0	-
Grade, %	-	0	-	-	0	-	-	0	-	-	0	-
Peak Hour Factor	92	92	92	92	92	92	92	92	92	92	92	92
Heavy Vehicles, %	2	2	2	2	2	2	2	2	2	2	2	2
Mvmt Flow	0	3	5	3	2	14	16	213	3	9	172	11

Major/Minor	Minor2		Minor1		Major1			Major2				
Conflicting Flow All	330	438	86	351	446	107	183	0	0	216	0	0
Stage 1	190	190	-	245	245	-	-	-	-	-	-	-
Stage 2	140	248	-	106	201	-	-	-	-	-	-	-
Critical Hdwy	7.54	6.54	6.94	7.54	6.54	6.94	4.14	-	-	4.14	-	-
Critical Hdwy Stg 1	6.54	5.54	-	6.54	5.54	-	-	-	-	-	-	-
Critical Hdwy Stg 2	6.54	5.54	-	6.54	5.54	-	-	-	-	-	-	-
Follow-up Hdwy	3.52	4.02	3.32	3.52	4.02	3.32	2.22	-	-	2.22	-	-
Pot Cap-1 Maneuver	599	511	956	579	506	926	1389	-	-	1351	-	-
Stage 1	794	742	-	737	702	-	-	-	-	-	-	-
Stage 2	849	700	-	888	734	-	-	-	-	-	-	-
Platoon blocked, %								-	-	-	-	-
Mov Cap-1 Maneuver	580	501	956	565	496	926	1389	-	-	1351	-	-
Mov Cap-2 Maneuver	580	501	-	565	496	-	-	-	-	-	-	-
Stage 1	784	737	-	728	694	-	-	-	-	-	-	-
Stage 2	824	692	-	873	729	-	-	-	-	-	-	-

Approach	EB		WB		NB		SB	
HCM Control Delay, s	10.1		9.7		0.5		0.3	
HCM LOS	B		A					

Minor Lane/Major Mvmt	NBL	NBT	NBR	EBLn1	EBLn2	WBLn1	WBLn2	SBL	SBT	SBR
Capacity (veh/h)	1389	-	-	501	956	535	926	1351	-	-
HCM Lane V/C Ratio	0.012	-	-	0.007	0.006	0.01	0.015	0.006	-	-
HCM Control Delay (s)	7.6	-	-	12.2	8.8	11.8	8.9	7.7	-	-
HCM Lane LOS	A	-	-	B	A	B	A	A	-	-
HCM 95th %tile Q(veh)	0	-	-	0	0	0	0	0	-	-

Intersection												
Int Delay, s/veh	2											
Movement	EBL	EBT	EBR	WBL	WBT	WBR	NBL	NBT	NBR	SBL	SBT	SBR
Lane Configurations		↕	↗		↕	↗	↖	↕	↖	↖	↕	↗
Traffic Vol, veh/h	8	3	14	2	7	14	17	135	0	6	107	10
Future Vol, veh/h	8	3	14	2	7	14	17	135	0	6	107	10
Conflicting Peds, #/hr	0	0	0	0	0	0	0	0	0	0	0	0
Sign Control	Stop	Stop	Stop	Stop	Stop	Stop	Free	Free	Free	Free	Free	Free
RT Channelized	-	-	None	-	-	None	-	-	None	-	-	None
Storage Length	-	-	0	-	-	0	0	-	0	0	-	0
Veh in Median Storage, #	-	0	-	-	0	-	-	0	-	-	0	-
Grade, %	-	0	-	-	0	-	-	0	-	-	0	-
Peak Hour Factor	92	92	92	92	92	92	92	92	92	92	92	92
Heavy Vehicles, %	2	2	2	2	2	2	2	2	2	2	2	2
Mvmt Flow	9	3	15	2	8	15	18	147	0	7	116	11

Major/Minor	Minor2		Minor1			Major1			Major2			
Conflicting Flow All	244	313	58	257	324	74	127	0	0	147	0	0
Stage 1	130	130	-	183	183	-	-	-	-	-	-	-
Stage 2	114	183	-	74	141	-	-	-	-	-	-	-
Critical Hdwy	7.54	6.54	6.94	7.54	6.54	6.94	4.14	-	-	4.14	-	-
Critical Hdwy Stg 1	6.54	5.54	-	6.54	5.54	-	-	-	-	-	-	-
Critical Hdwy Stg 2	6.54	5.54	-	6.54	5.54	-	-	-	-	-	-	-
Follow-up Hdwy	3.52	4.02	3.32	3.52	4.02	3.32	2.22	-	-	2.22	-	-
Pot Cap-1 Maneuver	690	601	996	675	592	973	1457	-	-	1432	-	-
Stage 1	860	788	-	801	747	-	-	-	-	-	-	-
Stage 2	879	747	-	927	779	-	-	-	-	-	-	-
Platoon blocked, %								-	-	-	-	-
Mov Cap-1 Maneuver	664	591	996	653	582	973	1457	-	-	1432	-	-
Mov Cap-2 Maneuver	664	591	-	653	582	-	-	-	-	-	-	-
Stage 1	850	784	-	791	738	-	-	-	-	-	-	-
Stage 2	846	738	-	905	775	-	-	-	-	-	-	-

Approach	EB		WB			NB			SB		
HCM Control Delay, s	9.6		9.7			0.8			0.4		
HCM LOS	A		A								

Minor Lane/Major Mvmt	NBL	NBT	NBR	EBLn1	EBLn2	WBLn1	WBLn2	SBL	SBT	SBR
Capacity (veh/h)	1457	-	-	642	996	596	973	1432	-	-
HCM Lane V/C Ratio	0.013	-	-	0.019	0.015	0.016	0.016	0.005	-	-
HCM Control Delay (s)	7.5	-	-	10.7	8.7	11.1	8.8	7.5	-	-
HCM Lane LOS	A	-	-	B	A	B	A	A	-	-
HCM 95th %tile Q(veh)	0	-	-	0.1	0	0.1	0	0	-	-

Intersection												
Int Delay, s/veh	3.7											
Movement	EBL	EBT	EBR	WBL	WBT	WBR	NBL	NBT	NBR	SBL	SBT	SBR
Lane Configurations		↔						↑↑	↑		↑	
Traffic Vol, veh/h	121	0	26	0	0	0	0	206	1	1	56	0
Future Vol, veh/h	121	0	26	0	0	0	0	206	1	1	56	0
Conflicting Peds, #/hr	0	0	0	0	0	0	0	0	0	0	0	0
Sign Control	Stop	Stop	Stop	Free	Free	Free	Free	Free	Free	Free	Free	Free
RT Channelized	-	-	None	-	-	None	-	-	None	-	-	None
Storage Length	-	-	-	-	-	-	-	-	0	-	-	-
Veh in Median Storage, #	-	0	-	-	-	-	-	0	-	-	0	-
Grade, %	-	0	-	-	0	-	-	0	-	-	0	-
Peak Hour Factor	92	92	92	92	92	92	92	92	92	92	92	92
Heavy Vehicles, %	2	2	2	2	2	2	2	2	2	2	2	2
Mvmt Flow	132	0	28	0	0	0	0	224	1	1	61	0

Major/Minor	Minor2			Major1			Major2		
Conflicting Flow All	175	288	61	-	0	0	225	0	0
Stage 1	63	63	-	-	-	-	-	-	-
Stage 2	112	225	-	-	-	-	-	-	-
Critical Hdwy	6.63	6.53	6.23	-	-	-	4.13	-	-
Critical Hdwy Stg 1	5.43	5.53	-	-	-	-	-	-	-
Critical Hdwy Stg 2	5.83	5.53	-	-	-	-	-	-	-
Follow-up Hdwy	3.519	4.019	3.319	-	-	-	2.219	-	-
Pot Cap-1 Maneuver	806	621	1004	0	-	-	1342	-	0
Stage 1	959	842	-	0	-	-	-	-	0
Stage 2	901	717	-	0	-	-	-	-	0
Platoon blocked, %									
Mov Cap-1 Maneuver	805	0	1004	-	-	-	1342	-	-
Mov Cap-2 Maneuver	805	0	-	-	-	-	-	-	-
Stage 1	959	0	-	-	-	-	-	-	-
Stage 2	900	0	-	-	-	-	-	-	-

Approach	EB	NB	SB
HCM Control Delay, s	10.3	0	0.1
HCM LOS	B		

Minor Lane/Major Mvmt	NBT	NBR	EBLn1	SBL	SBT
Capacity (veh/h)	-	-	834	1342	-
HCM Lane V/C Ratio	-	-	0.192	0.001	-
HCM Control Delay (s)	-	-	10.3	7.7	-
HCM Lane LOS	-	-	B	A	-
HCM 95th %tile Q(veh)	-	-	0.7	0	-

Intersection												
Int Delay, s/veh	2.7											
Movement	EBL	EBT	EBR	WBL	WBT	WBR	NBL	NBT	NBR	SBL	SBT	SBR
Lane Configurations		↔						↑↑	↑		↑	
Traffic Vol, veh/h	46	0	49	0	0	0	0	152	9	0	74	0
Future Vol, veh/h	46	0	49	0	0	0	0	152	9	0	74	0
Conflicting Peds, #/hr	0	0	0	0	0	0	0	0	0	0	0	0
Sign Control	Stop	Stop	Stop	Free	Free	Free	Free	Free	Free	Free	Free	Free
RT Channelized	-	-	None	-	-	None	-	-	None	-	-	None
Storage Length	-	-	-	-	-	-	-	-	0	-	-	-
Veh in Median Storage, #	-	0	-	-	-	-	-	0	-	-	0	-
Grade, %	-	0	-	-	0	-	-	0	-	-	0	-
Peak Hour Factor	92	92	92	92	92	92	92	92	92	92	92	92
Heavy Vehicles, %	2	2	2	2	2	2	2	2	2	2	2	2
Mvmt Flow	50	0	53	0	0	0	0	165	10	0	80	0

Major/Minor	Minor2			Major1			Major2		
Conflicting Flow All	163	255	80	-	0	0	-	-	0
Stage 1	80	80	-	-	-	-	-	-	-
Stage 2	83	175	-	-	-	-	-	-	-
Critical Hdwy	6.63	6.53	6.23	-	-	-	-	-	-
Critical Hdwy Stg 1	5.43	5.53	-	-	-	-	-	-	-
Critical Hdwy Stg 2	5.83	5.53	-	-	-	-	-	-	-
Follow-up Hdwy	3.519	4.019	3.319	-	-	-	-	-	-
Pot Cap-1 Maneuver	820	648	980	0	-	-	0	-	0
Stage 1	943	828	-	0	-	-	0	-	0
Stage 2	931	754	-	0	-	-	0	-	0
Platoon blocked, %									
Mov Cap-1 Maneuver	820	0	980	-	-	-	-	-	-
Mov Cap-2 Maneuver	820	0	-	-	-	-	-	-	-
Stage 1	943	0	-	-	-	-	-	-	-
Stage 2	931	0	-	-	-	-	-	-	-

Approach	EB	NB	SB
HCM Control Delay, s	9.5	0	0
HCM LOS	A		

Minor Lane/Major Mvmt	NBT	NBR	EBLn1	SBT
Capacity (veh/h)	-	-	895	-
HCM Lane V/C Ratio	-	-	0.115	-
HCM Control Delay (s)	-	-	9.5	-
HCM Lane LOS	-	-	A	-
HCM 95th %tile Q(veh)	-	-	0.4	-

Intersection												
Int Delay, s/veh	1.2											
Movement	EBL	EBT	EBR	WBL	WBT	WBR	NBL	NBT	NBR	SBL	SBT	SBR
Lane Configurations					↕			↕			↑	↗
Traffic Vol, veh/h	0	0	0	4	0	5	22	89	0	0	58	33
Future Vol, veh/h	0	0	0	4	0	5	22	89	0	0	58	33
Conflicting Peds, #/hr	0	0	0	0	0	0	0	0	0	0	0	0
Sign Control	Free	Free	Free	Stop	Stop	Stop	Free	Free	Free	Free	Free	Free
RT Channelized	-	-	None	-	-	None	-	-	None	-	-	None
Storage Length	-	-	-	-	-	-	-	-	-	-	-	0
Veh in Median Storage, #	-	-	-	-	0	-	-	0	-	-	0	-
Grade, %	-	0	-	-	0	-	-	0	-	-	0	-
Peak Hour Factor	92	92	92	92	92	92	92	92	92	92	92	92
Heavy Vehicles, %	2	2	2	2	2	2	2	2	2	2	2	2
Mvmt Flow	0	0	0	4	0	5	24	97	0	0	63	36

Major/Minor	Minor1		Major1		Major2		
Conflicting Flow All	226	244	97	99	0	-	0
Stage 1	145	145	-	-	-	-	-
Stage 2	81	99	-	-	-	-	-
Critical Hdwy	6.42	6.52	6.22	4.12	-	-	-
Critical Hdwy Stg 1	5.42	5.52	-	-	-	-	-
Critical Hdwy Stg 2	5.42	5.52	-	-	-	-	-
Follow-up Hdwy	3.518	4.018	3.318	2.218	-	-	-
Pot Cap-1 Maneuver	762	658	959	1494	-	0	0
Stage 1	882	777	-	-	-	0	0
Stage 2	942	813	-	-	-	0	0
Platoon blocked, %					-	-	-
Mov Cap-1 Maneuver	749	0	959	1494	-	-	-
Mov Cap-2 Maneuver	749	0	-	-	-	-	-
Stage 1	867	0	-	-	-	-	-
Stage 2	942	0	-	-	-	-	-

Approach	WB	NB	SB
HCM Control Delay, s	9.3	1.5	0
HCM LOS	A		

Minor Lane/Major Mvmt	NBL	NBTWBLn1	SBT	SBR
Capacity (veh/h)	1494	-	853	-
HCM Lane V/C Ratio	0.016	-	0.011	-
HCM Control Delay (s)	7.4	0	9.3	-
HCM Lane LOS	A	A	A	-
HCM 95th %tile Q(veh)	0	-	0	-

Intersection												
Int Delay, s/veh	0.6											
Movement	EBL	EBT	EBR	WBL	WBT	WBR	NBL	NBT	NBR	SBL	SBT	SBR
Lane Configurations					↕			↕			↑	↗
Traffic Vol, veh/h	0	0	0	6	0	4	13	116	76	0	70	47
Future Vol, veh/h	0	0	0	6	0	4	13	116	76	0	70	47
Conflicting Peds, #/hr	0	0	0	0	0	0	0	0	0	0	0	0
Sign Control	Free	Free	Free	Stop	Stop	Stop	Free	Free	Free	Free	Free	Free
RT Channelized	-	-	None	-	-	None	-	-	None	-	-	None
Storage Length	-	-	-	-	-	-	-	-	-	-	-	0
Veh in Median Storage, #	-	-	-	-	0	-	-	0	-	-	0	-
Grade, %	-	0	-	-	0	-	-	0	-	-	0	-
Peak Hour Factor	92	92	92	92	92	92	92	92	92	92	92	92
Heavy Vehicles, %	2	2	2	2	2	2	2	2	2	2	2	2
Mvmt Flow	0	0	0	7	0	4	14	126	83	0	76	51

Major/Minor	Minor1		Major1		Major2		
Conflicting Flow All	298	323	168	127	0	0	-
Stage 1	196	196	-	-	-	-	-
Stage 2	102	127	-	-	-	-	-
Critical Hdwy	6.42	6.52	6.22	4.12	-	-	-
Critical Hdwy Stg 1	5.42	5.52	-	-	-	-	-
Critical Hdwy Stg 2	5.42	5.52	-	-	-	-	-
Follow-up Hdwy	3.518	4.018	3.318	2.218	-	-	-
Pot Cap-1 Maneuver	693	595	876	1459	-	-	0
Stage 1	837	739	-	-	-	-	0
Stage 2	922	791	-	-	-	-	0
Platoon blocked, %					-	-	-
Mov Cap-1 Maneuver	685	0	876	1459	-	-	-
Mov Cap-2 Maneuver	685	0	-	-	-	-	-
Stage 1	828	0	-	-	-	-	-
Stage 2	922	0	-	-	-	-	-

Approach	WB	NB	SB
HCM Control Delay, s	9.9	0.5	0
HCM LOS	A		

Minor Lane/Major Mvmt	NBL	NBT	NBRWBLn1	SBT	SBR
Capacity (veh/h)	1459	-	-	750	-
HCM Lane V/C Ratio	0.01	-	-	0.014	-
HCM Control Delay (s)	7.5	0	-	9.9	-
HCM Lane LOS	A	A	-	A	-
HCM 95th %tile Q(veh)	0	-	-	0	-

APPENDIX C : CONSTRUCTION YEAR PROJECT ANALYSIS WORKSHEETS

Intersection						
Int Delay, s/veh	0					
Movement	EBT	EBR	WBL	WBT	NBL	NBR
Lane Configurations						
Traffic Vol, veh/h	64	0	0	57	0	0
Future Vol, veh/h	64	0	0	57	0	0
Conflicting Peds, #/hr	0	0	0	0	0	0
Sign Control	Free	Free	Free	Free	Stop	Stop
RT Channelized	-	None	-	None	-	None
Storage Length	-	-	-	-	0	-
Veh in Median Storage, #	0	-	-	0	0	-
Grade, %	0	-	-	0	0	-
Peak Hour Factor	92	92	92	92	92	92
Heavy Vehicles, %	2	2	2	2	2	2
Mvmt Flow	70	0	0	62	0	0

Major/Minor	Major1	Major2	Minor1		
Conflicting Flow All	0	0	70	0	132
Stage 1	-	-	-	-	70
Stage 2	-	-	-	-	62
Critical Hdwy	-	-	4.12	-	6.42
Critical Hdwy Stg 1	-	-	-	-	5.42
Critical Hdwy Stg 2	-	-	-	-	5.42
Follow-up Hdwy	-	-	2.218	-	3.518
Pot Cap-1 Maneuver	-	-	1531	-	862
Stage 1	-	-	-	-	953
Stage 2	-	-	-	-	961
Platoon blocked, %	-	-	-	-	-
Mov Cap-1 Maneuver	-	-	1531	-	862
Mov Cap-2 Maneuver	-	-	-	-	862
Stage 1	-	-	-	-	953
Stage 2	-	-	-	-	961

Approach	EB	WB	NB
HCM Control Delay, s	0	0	0
HCM LOS			A

Minor Lane/Major Mvmt	NBLn1	EBT	EBR	WBL	WBT
Capacity (veh/h)	-	-	-	1531	-
HCM Lane V/C Ratio	-	-	-	-	-
HCM Control Delay (s)	0	-	-	0	-
HCM Lane LOS	A	-	-	A	-
HCM 95th %tile Q(veh)	-	-	-	0	-

Intersection						
Int Delay, s/veh	0					
Movement	EBT	EBR	WBL	WBT	NBL	NBR
Lane Configurations						
Traffic Vol, veh/h	70	0	0	87	0	0
Future Vol, veh/h	70	0	0	87	0	0
Conflicting Peds, #/hr	0	0	0	0	0	0
Sign Control	Free	Free	Free	Free	Stop	Stop
RT Channelized	-	None	-	None	-	None
Storage Length	-	-	-	-	0	-
Veh in Median Storage, #	0	-	-	0	0	-
Grade, %	0	-	-	0	0	-
Peak Hour Factor	92	92	92	92	92	92
Heavy Vehicles, %	2	2	2	2	2	2
Mvmt Flow	76	0	0	95	0	0

Major/Minor	Major1	Major2	Minor1	Minor2	Minor3
Conflicting Flow All	0	0	76	0	171
Stage 1	-	-	-	-	76
Stage 2	-	-	-	-	95
Critical Hdwy	-	-	4.12	-	6.42
Critical Hdwy Stg 1	-	-	-	-	5.42
Critical Hdwy Stg 2	-	-	-	-	5.42
Follow-up Hdwy	-	-	2.218	-	3.518
Pot Cap-1 Maneuver	-	-	1523	-	819
Stage 1	-	-	-	-	947
Stage 2	-	-	-	-	929
Platoon blocked, %	-	-	-	-	-
Mov Cap-1 Maneuver	-	-	1523	-	819
Mov Cap-2 Maneuver	-	-	-	-	819
Stage 1	-	-	-	-	947
Stage 2	-	-	-	-	929

Approach	EB	WB	NB
HCM Control Delay, s	0	0	0
HCM LOS			A

Minor Lane/Major Mvmt	NBLn1	EBT	EBR	WBL	WBT
Capacity (veh/h)	-	-	-	1523	-
HCM Lane V/C Ratio	-	-	-	-	-
HCM Control Delay (s)	0	-	-	0	-
HCM Lane LOS	A	-	-	A	-
HCM 95th %tile Q(veh)	-	-	-	0	-

Intersection						
Int Delay, s/veh	1.3					
Movement	EBL	EBT	WBT	WBR	SBL	SBR
Lane Configurations	↖	↑	↗		↖	↗
Traffic Vol, veh/h	11	65	57	7	6	7
Future Vol, veh/h	11	65	57	7	6	7
Conflicting Peds, #/hr	0	0	0	0	0	0
Sign Control	Free	Free	Free	Free	Stop	Stop
RT Channelized	-	None	-	None	-	None
Storage Length	0	-	-	-	0	0
Veh in Median Storage, #	-	0	0	-	0	-
Grade, %	-	0	0	-	0	-
Peak Hour Factor	92	92	92	92	92	92
Heavy Vehicles, %	2	2	2	2	2	2
Mvmt Flow	12	71	62	8	7	8

Major/Minor	Major1	Major2	Minor2		
Conflicting Flow All	70	0	-	0	161
Stage 1	-	-	-	-	66
Stage 2	-	-	-	-	95
Critical Hdwy	4.12	-	-	-	6.42
Critical Hdwy Stg 1	-	-	-	-	5.42
Critical Hdwy Stg 2	-	-	-	-	5.42
Follow-up Hdwy	2.218	-	-	-	3.518
Pot Cap-1 Maneuver	1531	-	-	-	830
Stage 1	-	-	-	-	957
Stage 2	-	-	-	-	929
Platoon blocked, %		-	-	-	
Mov Cap-1 Maneuver	1531	-	-	-	823
Mov Cap-2 Maneuver	-	-	-	-	823
Stage 1	-	-	-	-	949
Stage 2	-	-	-	-	929

Approach	EB	WB	SB
HCM Control Delay, s	1.1	0	9
HCM LOS			A

Minor Lane/Major Mvmt	EBL	EBT	WBT	WBR	SBLn1	SBLn2
Capacity (veh/h)	1531	-	-	-	823	998
HCM Lane V/C Ratio	0.008	-	-	-	0.008	0.008
HCM Control Delay (s)	7.4	-	-	-	9.4	8.6
HCM Lane LOS	A	-	-	-	A	A
HCM 95th %tile Q(veh)	0	-	-	-	0	0

Intersection

Int Delay, s/veh 1.1

Movement	EBL	EBT	WBT	WBR	SBL	SBR
Lane Configurations	↘	↑	↗		↘	↗
Traffic Vol, veh/h	5	70	87	11	2	18
Future Vol, veh/h	5	70	87	11	2	18
Conflicting Peds, #/hr	0	0	0	0	0	0
Sign Control	Free	Free	Free	Free	Stop	Stop
RT Channelized	-	None	-	None	-	None
Storage Length	0	-	-	-	0	0
Veh in Median Storage, #	-	0	0	-	0	-
Grade, %	-	0	0	-	0	-
Peak Hour Factor	92	92	92	92	92	92
Heavy Vehicles, %	2	2	2	2	2	2
Mvmt Flow	5	76	95	12	2	20

























Major/Minor	Major1	Major2	Minor2
Conflicting Flow All	107	0	0 187 101
Stage 1	-	-	- 101 -
Stage 2	-	-	- 86 -
Critical Hdwy	4.12	-	- 6.42 6.22
Critical Hdwy Stg 1	-	-	- 5.42 -
Critical Hdwy Stg 2	-	-	- 5.42 -
Follow-up Hdwy	2.218	-	- 3.518 3.318
Pot Cap-1 Maneuver	1484	-	- 802 954
Stage 1	-	-	- 923 -
Stage 2	-	-	- 937 -
Platoon blocked, %		-	- -
Mov Cap-1 Maneuver	1484	-	- 800 954
Mov Cap-2 Maneuver	-	-	- 800 -
Stage 1	-	-	- 920 -
Stage 2	-	-	- 937 -

Approach	EB	WB	SB
HCM Control Delay, s	0.5	0	9
HCM LOS			A

Minor Lane/Major Mvmt	EBL	EBT	WBT	WBR	SBLn1	SBLn2
Capacity (veh/h)	1484	-	-	-	800	954
HCM Lane V/C Ratio	0.004	-	-	-	0.003	0.021
HCM Control Delay (s)	7.4	-	-	-	9.5	8.9
HCM Lane LOS	A	-	-	-	A	A
HCM 95th %tile Q(veh)	0	-	-	-	0	0.1

HCM 2010 Signalized Intersection Capacity Analysis
12: CA 7 & CA 98

01/07/2021

												
Movement	EBL	EBT	EBR	WBL	WBT	WBR	NBL	NBT	NBR	SBL	SBT	SBR
Lane Configurations												
Traffic Volume (veh/h)	22	26	112	28	27	8	56	186	33	4	130	42
Future Volume (veh/h)	22	26	112	28	27	8	56	186	33	4	130	42
Number	7	4	14	3	8	18	5	2	12	1	6	16
Initial Q, veh	0	0	0	0	0	0	0	0	0	0	0	0
Ped-Bike Adj (A_pbT)	1.00		1.00	1.00		1.00	1.00		1.00	1.00		1.00
Parking Bus Adj	1.00	1.00	1.00	1.00	1.00	1.00	1.00	1.00	1.00	1.00	1.00	1.00
Adj Sat Flow, veh/h/ln	1863	1863	1863	1863	1863	1863	1863	1863	1863	1863	1863	1863
Adj Flow Rate, veh/h	24	28	122	30	29	9	61	202	36	4	141	46
Adj No. of Lanes	1	1	2	1	1	1	2	2	1	1	2	1
Peak Hour Factor	0.92	0.92	0.92	0.92	0.92	0.92	0.92	0.92	0.92	0.92	0.92	0.92
Percent Heavy Veh, %	2	2	2	2	2	2	2	2	2	2	2	2
Opposing Right Turn Influence	Yes			Yes			Yes			Yes		
Cap, veh/h	693	745	1115	642	745	633	1187	1416	633	574	1416	633
HCM Platoon Ratio	1.00	1.00	1.00	1.00	1.00	1.00	1.00	1.00	1.00	1.00	1.00	1.00
Prop Arrive On Green	0.40	0.40	0.40	0.40	0.40	0.40	0.40	0.40	0.40	0.40	0.40	0.40
Ln Grp Delay, s/veh	8.6	8.3	8.7	8.7	8.3	8.2	9.1	8.8	8.5	9.2	8.6	8.6
Ln Grp LOS	A	A	A	A	A	A	A	A	A	A	A	A
Approach Vol, veh/h		174			68			299			191	
Approach Delay, s/veh		8.6			8.5			8.8			8.6	
Approach LOS		A			A			A			A	
Timer:		1	2	3	4	5	6	7	8			
Assigned Phs			2		4		6		8			
Case No			5.0		5.0		5.0		5.0			
Phs Duration (G+Y+Rc), s			22.5		22.5		22.5		22.5			
Change Period (Y+Rc), s			4.5		4.5		4.5		4.5			
Max Green (Gmax), s			18.0		18.0		18.0		18.0			
Max Allow Headway (MAH), s			4.9		4.2		4.9		4.6			
Max Q Clear (g_c+I1), s			3.9		3.2		3.7		3.1			
Green Ext Time (g_e), s			1.3		0.5		0.8		0.2			
Prob of Phs Call (p_c)			1.00		1.00		1.00		1.00			
Prob of Max Out (p_x)			0.00		0.00		0.00		0.00			
Left-Turn Movement Data												
Assigned Mvmt			5		7		1		3			
Mvmt Sat Flow, veh/h			2312		1364		1138		1232			
Through Movement Data												
Assigned Mvmt			2		4		6		8			
Mvmt Sat Flow, veh/h			3539		1863		3539		1863			
Right-Turn Movement Data												
Assigned Mvmt			12		14		16		18			
Mvmt Sat Flow, veh/h			1583		2787		1583		1583			
Left Lane Group Data												
Assigned Mvmt		0	5	0	7	0	1	0	3			
Lane Assignment												

HCM 2010 Signalized Intersection Capacity Analysis
 12: CA 7 & CA 98

01/07/2021

Lanes in Grp	0	2	0	1	0	1	0	1
Grp Vol (v), veh/h	0	61	0	24	0	4	0	30
Grp Sat Flow (s), veh/h/ln	0	1156	0	1364	0	1138	0	1232
Q Serve Time (g_s), s	0.0	0.8	0.0	0.5	0.0	0.1	0.0	0.7
Cycle Q Clear Time (g_c), s	0.0	1.9	0.0	0.9	0.0	1.7	0.0	1.1
Perm LT Sat Flow (s_l), veh/h/ln	0	1156	0	1364	0	1138	0	1232
Shared LT Sat Flow (s_sh), veh/h/ln	0	0	0	0	0	0	0	0
Perm LT Eff Green (g_p), s	0.0	18.0	0.0	18.0	0.0	18.0	0.0	18.0
Perm LT Serve Time (g_u), s	0.0	16.9	0.0	17.6	0.0	16.4	0.0	17.6
Perm LT Q Serve Time (g_ps), s	0.0	0.8	0.0	0.5	0.0	0.1	0.0	0.7
Time to First Blk (g_f), s	0.0	0.0	0.0	0.0	0.0	0.0	0.0	0.0
Serve Time pre Blk (g_fs), s	0.0	0.0	0.0	0.0	0.0	0.0	0.0	0.0
Prop LT Inside Lane (P_L)	0.00	1.00	0.00	1.00	0.00	1.00	0.00	1.00
Lane Grp Cap (c), veh/h	0	1187	0	693	0	574	0	642
V/C Ratio (X)	0.00	0.05	0.00	0.03	0.00	0.01	0.00	0.05
Avail Cap (c_a), veh/h	0	1187	0	693	0	574	0	642
Upstream Filter (I)	0.00	1.00	0.00	1.00	0.00	1.00	0.00	1.00
Uniform Delay (d1), s/veh	0.0	9.0	0.0	8.5	0.0	9.1	0.0	8.6
Incr Delay (d2), s/veh	0.0	0.1	0.0	0.1	0.0	0.0	0.0	0.1
Initial Q Delay (d3), s/veh	0.0	0.0	0.0	0.0	0.0	0.0	0.0	0.0
Control Delay (d), s/veh	0.0	9.1	0.0	8.6	0.0	9.2	0.0	8.7
1st-Term Q (Q1), veh/ln	0.0	0.2	0.0	0.2	0.0	0.0	0.0	0.2
2nd-Term Q (Q2), veh/ln	0.0	0.0	0.0	0.0	0.0	0.0	0.0	0.0
3rd-Term Q (Q3), veh/ln	0.0	0.0	0.0	0.0	0.0	0.0	0.0	0.0
%ile Back of Q Factor (f_B%)	0.00	1.00	0.00	1.00	0.00	1.00	0.00	1.00
%ile Back of Q (50%), veh/ln	0.0	0.3	0.0	0.2	0.0	0.0	0.0	0.3
%ile Storage Ratio (RQ%)	0.00	0.00	0.00	0.00	0.00	0.00	0.00	0.00
Initial Q (Qb), veh	0.0	0.0	0.0	0.0	0.0	0.0	0.0	0.0
Final (Residual) Q (Qe), veh	0.0	0.0	0.0	0.0	0.0	0.0	0.0	0.0
Sat Delay (ds), s/veh	0.0	0.0	0.0	0.0	0.0	0.0	0.0	0.0
Sat Q (Qs), veh	0.0	0.0	0.0	0.0	0.0	0.0	0.0	0.0
Sat Cap (cs), veh/h	0	0	0	0	0	0	0	0
Initial Q Clear Time (tc), h	0.0	0.0	0.0	0.0	0.0	0.0	0.0	0.0
Middle Lane Group Data								
Assigned Mvmt	0	2	0	4	0	6	0	8
Lane Assignment		T		T		T		T
Lanes in Grp	0	2	0	1	0	2	0	1
Grp Vol (v), veh/h	0	202	0	28	0	141	0	29
Grp Sat Flow (s), veh/h/ln	0	1770	0	1863	0	1770	0	1863
Q Serve Time (g_s), s	0.0	1.6	0.0	0.4	0.0	1.1	0.0	0.4
Cycle Q Clear Time (g_c), s	0.0	1.6	0.0	0.4	0.0	1.1	0.0	0.4
Lane Grp Cap (c), veh/h	0	1416	0	745	0	1416	0	745
V/C Ratio (X)	0.00	0.14	0.00	0.04	0.00	0.10	0.00	0.04
Avail Cap (c_a), veh/h	0	1416	0	745	0	1416	0	745
Upstream Filter (I)	0.00	1.00	0.00	1.00	0.00	1.00	0.00	1.00
Uniform Delay (d1), s/veh	0.0	8.6	0.0	8.2	0.0	8.4	0.0	8.2
Incr Delay (d2), s/veh	0.0	0.2	0.0	0.1	0.0	0.1	0.0	0.1
Initial Q Delay (d3), s/veh	0.0	0.0	0.0	0.0	0.0	0.0	0.0	0.0
Control Delay (d), s/veh	0.0	8.8	0.0	8.3	0.0	8.6	0.0	8.3
1st-Term Q (Q1), veh/ln	0.0	0.8	0.0	0.2	0.0	0.5	0.0	0.2

Baseline

Synchro 10 Report
 Page 2

PC ORIGINAL PKG

HCM 2010 Signalized Intersection Capacity Analysis
 12: CA 7 & CA 98

01/07/2021

2nd-Term Q (Q2), veh/ln	0.0	0.0	0.0	0.0	0.0	0.0	0.0	0.0
3rd-Term Q (Q3), veh/ln	0.0	0.0	0.0	0.0	0.0	0.0	0.0	0.0
%ile Back of Q Factor (f_B%)	0.00	1.00	0.00	1.00	0.00	1.00	0.00	1.00
%ile Back of Q (50%), veh/ln	0.0	0.8	0.0	0.2	0.0	0.6	0.0	0.2
%ile Storage Ratio (RQ%)	0.00	0.01	0.00	0.00	0.00	0.02	0.00	0.00
Initial Q (Qb), veh	0.0	0.0	0.0	0.0	0.0	0.0	0.0	0.0
Final (Residual) Q (Qe), veh	0.0	0.0	0.0	0.0	0.0	0.0	0.0	0.0
Sat Delay (ds), s/veh	0.0	0.0	0.0	0.0	0.0	0.0	0.0	0.0
Sat Q (Qs), veh	0.0	0.0	0.0	0.0	0.0	0.0	0.0	0.0
Sat Cap (cs), veh/h	0	0	0	0	0	0	0	0
Initial Q Clear Time (tc), h	0.0	0.0	0.0	0.0	0.0	0.0	0.0	0.0

Right Lane Group Data
























Assigned Mvmt	0	12	0	14	0	16	0	18
Lane Assignment		R		R		R		R
Lanes in Grp	0	1	0	2	0	1	0	1
Grp Vol (v), veh/h	0	36	0	122	0	46	0	9
Grp Sat Flow (s), veh/h/ln	0	1583	0	1393	0	1583	0	1583
Q Serve Time (g_s), s	0.0	0.6	0.0	1.2	0.0	0.8	0.0	0.2
Cycle Q Clear Time (g_c), s	0.0	0.6	0.0	1.2	0.0	0.8	0.0	0.2
Prot RT Sat Flow (s_R), veh/h/ln	0.0	0.0	0.0	0.0	0.0	0.0	0.0	0.0
Prot RT Eff Green (g_R), s	0.0	0.0	0.0	0.0	0.0	0.0	0.0	0.0
Prop RT Outside Lane (P_R)	0.00	1.00	0.00	1.00	0.00	1.00	0.00	1.00
Lane Grp Cap (c), veh/h	0	633	0	1115	0	633	0	633
V/C Ratio (X)	0.00	0.06	0.00	0.11	0.00	0.07	0.00	0.01
Avail Cap (c_a), veh/h	0	633	0	1115	0	633	0	633
Upstream Filter (I)	0.00	1.00	0.00	1.00	0.00	1.00	0.00	1.00
Uniform Delay (d1), s/veh	0.0	8.3	0.0	8.5	0.0	8.3	0.0	8.1
Incr Delay (d2), s/veh	0.0	0.2	0.0	0.2	0.0	0.2	0.0	0.0
Initial Q Delay (d3), s/veh	0.0	0.0	0.0	0.0	0.0	0.0	0.0	0.0
Control Delay (d), s/veh	0.0	8.5	0.0	8.7	0.0	8.6	0.0	8.2
1st-Term Q (Q1), veh/ln	0.0	0.3	0.0	0.5	0.0	0.3	0.0	0.1
2nd-Term Q (Q2), veh/ln	0.0	0.0	0.0	0.0	0.0	0.0	0.0	0.0
3rd-Term Q (Q3), veh/ln	0.0	0.0	0.0	0.0	0.0	0.0	0.0	0.0
%ile Back of Q Factor (f_B%)	0.00	1.00	0.00	1.00	0.00	1.00	0.00	1.00
%ile Back of Q (50%), veh/ln	0.0	0.3	0.0	0.5	0.0	0.4	0.0	0.1
%ile Storage Ratio (RQ%)	0.00	0.00	0.00	0.00	0.00	0.02	0.00	0.00
Initial Q (Qb), veh	0.0	0.0	0.0	0.0	0.0	0.0	0.0	0.0
Final (Residual) Q (Qe), veh	0.0	0.0	0.0	0.0	0.0	0.0	0.0	0.0
Sat Delay (ds), s/veh	0.0	0.0	0.0	0.0	0.0	0.0	0.0	0.0
Sat Q (Qs), veh	0.0	0.0	0.0	0.0	0.0	0.0	0.0	0.0
Sat Cap (cs), veh/h	0	0	0	0	0	0	0	0
Initial Q Clear Time (tc), h	0.0	0.0	0.0	0.0	0.0	0.0	0.0	0.0

Intersection Summary

HCM 2010 Ctrl Delay	8.7
HCM 2010 LOS	A

HCM 2010 Signalized Intersection Capacity Analysis
 12: CA 7 & CA 98

12/15/2021

												
Movement	EBL	EBT	EBR	WBL	WBT	WBR	NBL	NBT	NBR	SBL	SBT	SBR
Lane Configurations												
Traffic Volume (veh/h)	38	55	103	15	109	9	99	112	18	0	68	65
Future Volume (veh/h)	38	55	103	15	109	9	99	112	18	0	68	65
Number	7	4	14	3	8	18	5	2	12	1	6	16
Initial Q, veh	0	0	0	0	0	0	0	0	0	0	0	0
Ped-Bike Adj (A_pbT)	1.00		1.00	1.00		1.00	1.00		1.00	1.00		1.00
Parking Bus Adj	1.00	1.00	1.00	1.00	1.00	1.00	1.00	1.00	1.00	1.00	1.00	1.00
Adj Sat Flow, veh/h/ln	1863	1863	1863	1863	1863	1863	1863	1863	1863	1863	1863	1863
Adj Flow Rate, veh/h	41	60	112	16	118	10	108	122	20	0	74	71
Adj No. of Lanes	1	1	2	1	1	1	2	2	1	1	2	1
Peak Hour Factor	0.92	0.92	0.92	0.92	0.92	0.92	0.92	0.92	0.92	0.92	0.92	0.92
Percent Heavy Veh, %	2	2	2	2	2	2	2	2	2	2	2	2
Opposing Right Turn Influence	Yes			Yes			Yes			Yes		
Cap, veh/h	612	745	1115	619	745	633	1250	1416	633	160	1416	633
HCM Platoon Ratio	1.00	1.00	1.00	1.00	1.00	1.00	1.00	1.00	1.00	1.00	1.00	1.00
Prop Arrive On Green	0.40	0.40	0.40	0.40	0.40	0.40	0.40	0.40	0.40	0.00	0.40	0.40
Ln Grp Delay, s/veh	9.8	8.6	8.6	8.8	9.1	8.2	9.0	8.5	8.3	0.0	8.3	8.8
Ln Grp LOS	A	A	A	A	A	A	A	A	A		A	A
Approach Vol, veh/h		213			144			250			145	
Approach Delay, s/veh		8.8			9.0			8.7			8.6	
Approach LOS		A			A			A			A	
Timer:		1	2	3	4	5	6	7	8			
Assigned Phs			2		4		6		8			
Case No			5.0		5.0		5.0		5.0			
Phs Duration (G+Y+Rc), s			22.5		22.5		22.5		22.5			
Change Period (Y+Rc), s			4.5		4.5		4.5		4.5			
Max Green (Gmax), s			18.0		18.0		18.0		18.0			
Max Allow Headway (MAH), s			4.7		4.4		4.7		5.0			
Max Q Clear (g_c+I1), s			3.9		4.8		3.3		3.8			
Green Ext Time (g_e), s			1.0		0.7		0.5		0.5			
Prob of Phs Call (p_c)			1.00		1.00		1.00		1.00			
Prob of Max Out (p_x)			0.00		0.00		0.00		0.00			
Left-Turn Movement Data												
Assigned Mvmt			5		7		1		3			
Mvmt Sat Flow, veh/h			2402		1257		1241		1208			
Through Movement Data												
Assigned Mvmt			2		4		6		8			
Mvmt Sat Flow, veh/h			3539		1863		3539		1863			
Right-Turn Movement Data												
Assigned Mvmt			12		14		16		18			
Mvmt Sat Flow, veh/h			1583		2787		1583		1583			
Left Lane Group Data												
Assigned Mvmt		0	5	0	7	0	1	0	3			
Lane Assignment												

HCM 2010 Signalized Intersection Capacity Analysis
 12: CA 7 & CA 98

12/15/2021

Lanes in Grp	0	2	0	1	0	1	0	1
Grp Vol (v), veh/h	0	108	0	41	0	0	0	16
Grp Sat Flow (s), veh/h/ln	0	1201	0	1257	0	1241	0	1208
Q Serve Time (g_s), s	0.0	1.3	0.0	1.0	0.0	0.0	0.0	0.4
Cycle Q Clear Time (g_c), s	0.0	1.9	0.0	2.8	0.0	0.0	0.0	1.3
Perm LT Sat Flow (s_l), veh/h/ln	0	1201	0	1257	0	1241	0	1208
Shared LT Sat Flow (s_sh), veh/h/ln	0	0	0	0	0	0	0	0
Perm LT Eff Green (g_p), s	0.0	18.0	0.0	18.0	0.0	0.0	0.0	18.0
Perm LT Serve Time (g_u), s	0.0	17.4	0.0	16.2	0.0	0.0	0.0	17.1
Perm LT Q Serve Time (g_ps), s	0.0	1.3	0.0	1.0	0.0	0.0	0.0	0.4
Time to First Blk (g_f), s	0.0	0.0	0.0	0.0	0.0	0.0	0.0	0.0
Serve Time pre Blk (g_fs), s	0.0	0.0	0.0	0.0	0.0	0.0	0.0	0.0
Prop LT Inside Lane (P_L)	0.00	1.00	0.00	1.00	0.00	1.00	0.00	1.00
Lane Grp Cap (c), veh/h	0	1250	0	612	0	160	0	619
V/C Ratio (X)	0.00	0.09	0.00	0.07	0.00	0.00	0.00	0.03
Avail Cap (c_a), veh/h	0	1250	0	612	0	160	0	619
Upstream Filter (I)	0.00	1.00	0.00	1.00	0.00	0.00	0.00	1.00
Uniform Delay (d1), s/veh	0.0	8.8	0.0	9.5	0.0	0.0	0.0	8.8
Incr Delay (d2), s/veh	0.0	0.1	0.0	0.2	0.0	0.0	0.0	0.1
Initial Q Delay (d3), s/veh	0.0	0.0	0.0	0.0	0.0	0.0	0.0	0.0
Control Delay (d), s/veh	0.0	9.0	0.0	9.8	0.0	0.0	0.0	8.8
1st-Term Q (Q1), veh/ln	0.0	0.4	0.0	0.3	0.0	0.0	0.0	0.1
2nd-Term Q (Q2), veh/ln	0.0	0.0	0.0	0.0	0.0	0.0	0.0	0.0
3rd-Term Q (Q3), veh/ln	0.0	0.0	0.0	0.0	0.0	0.0	0.0	0.0
%ile Back of Q Factor (f_B%)	0.00	1.00	0.00	1.00	0.00	1.00	0.00	1.00
%ile Back of Q (50%), veh/ln	0.0	0.4	0.0	0.4	0.0	0.0	0.0	0.1
%ile Storage Ratio (RQ%)	0.00	0.01	0.00	0.00	0.00	0.00	0.00	0.00
Initial Q (Qb), veh	0.0	0.0	0.0	0.0	0.0	0.0	0.0	0.0
Final (Residual) Q (Qe), veh	0.0	0.0	0.0	0.0	0.0	0.0	0.0	0.0
Sat Delay (ds), s/veh	0.0	0.0	0.0	0.0	0.0	0.0	0.0	0.0
Sat Q (Qs), veh	0.0	0.0	0.0	0.0	0.0	0.0	0.0	0.0
Sat Cap (cs), veh/h	0	0	0	0	0	0	0	0
Initial Q Clear Time (tc), h	0.0	0.0	0.0	0.0	0.0	0.0	0.0	0.0
Middle Lane Group Data								
Assigned Mvmt	0	2	0	4	0	6	0	8
Lane Assignment		T		T		T		T
Lanes in Grp	0	2	0	1	0	2	0	1
Grp Vol (v), veh/h	0	122	0	60	0	74	0	118
Grp Sat Flow (s), veh/h/ln	0	1770	0	1863	0	1770	0	1863
Q Serve Time (g_s), s	0.0	1.0	0.0	0.9	0.0	0.6	0.0	1.8
Cycle Q Clear Time (g_c), s	0.0	1.0	0.0	0.9	0.0	0.6	0.0	1.8
Lane Grp Cap (c), veh/h	0	1416	0	745	0	1416	0	745
V/C Ratio (X)	0.00	0.09	0.00	0.08	0.00	0.05	0.00	0.16
Avail Cap (c_a), veh/h	0	1416	0	745	0	1416	0	745
Upstream Filter (I)	0.00	1.00	0.00	1.00	0.00	1.00	0.00	1.00
Uniform Delay (d1), s/veh	0.0	8.4	0.0	8.4	0.0	8.3	0.0	8.6
Incr Delay (d2), s/veh	0.0	0.1	0.0	0.2	0.0	0.1	0.0	0.5
Initial Q Delay (d3), s/veh	0.0	0.0	0.0	0.0	0.0	0.0	0.0	0.0
Control Delay (d), s/veh	0.0	8.5	0.0	8.6	0.0	8.3	0.0	9.1
1st-Term Q (Q1), veh/ln	0.0	0.5	0.0	0.4	0.0	0.3	0.0	0.9

Baseline

Synchro 10 Report
 Page 2

PC ORIGINAL PKG

HCM 2010 Signalized Intersection Capacity Analysis
 12: CA 7 & CA 98

12/15/2021

2nd-Term Q (Q2), veh/ln	0.0	0.0	0.0	0.0	0.0	0.0	0.0	0.1
3rd-Term Q (Q3), veh/ln	0.0	0.0	0.0	0.0	0.0	0.0	0.0	0.0
%ile Back of Q Factor (f_B%)	0.00	1.00	0.00	1.00	0.00	1.00	0.00	1.00
%ile Back of Q (50%), veh/ln	0.0	0.5	0.0	0.5	0.0	0.3	0.0	1.0
%ile Storage Ratio (RQ%)	0.00	0.01	0.00	0.00	0.00	0.01	0.00	0.00
Initial Q (Qb), veh	0.0	0.0	0.0	0.0	0.0	0.0	0.0	0.0
Final (Residual) Q (Qe), veh	0.0	0.0	0.0	0.0	0.0	0.0	0.0	0.0
Sat Delay (ds), s/veh	0.0	0.0	0.0	0.0	0.0	0.0	0.0	0.0
Sat Q (Qs), veh	0.0	0.0	0.0	0.0	0.0	0.0	0.0	0.0
Sat Cap (cs), veh/h	0	0	0	0	0	0	0	0
Initial Q Clear Time (tc), h	0.0	0.0	0.0	0.0	0.0	0.0	0.0	0.0

Right Lane Group Data

Assigned Mvmt	0	12	0	14	0	16	0	18
Lane Assignment		R		R		R		R
Lanes in Grp	0	1	0	2	0	1	0	1
Grp Vol (v), veh/h	0	20	0	112	0	71	0	10
Grp Sat Flow (s), veh/h/ln	0	1583	0	1393	0	1583	0	1583
Q Serve Time (g_s), s	0.0	0.3	0.0	1.1	0.0	1.3	0.0	0.2
Cycle Q Clear Time (g_c), s	0.0	0.3	0.0	1.1	0.0	1.3	0.0	0.2
Prot RT Sat Flow (s_R), veh/h/ln	0.0	0.0	0.0	0.0	0.0	0.0	0.0	0.0
Prot RT Eff Green (g_R), s	0.0	0.0	0.0	0.0	0.0	0.0	0.0	0.0
Prop RT Outside Lane (P_R)	0.00	1.00	0.00	1.00	0.00	1.00	0.00	1.00
Lane Grp Cap (c), veh/h	0	633	0	1115	0	633	0	633
V/C Ratio (X)	0.00	0.03	0.00	0.10	0.00	0.11	0.00	0.02
Avail Cap (c_a), veh/h	0	633	0	1115	0	633	0	633
Upstream Filter (I)	0.00	1.00	0.00	1.00	0.00	1.00	0.00	1.00
Uniform Delay (d1), s/veh	0.0	8.2	0.0	8.4	0.0	8.5	0.0	8.2
Incr Delay (d2), s/veh	0.0	0.1	0.0	0.2	0.0	0.4	0.0	0.0
Initial Q Delay (d3), s/veh	0.0	0.0	0.0	0.0	0.0	0.0	0.0	0.0
Control Delay (d), s/veh	0.0	8.3	0.0	8.6	0.0	8.8	0.0	8.2
1st-Term Q (Q1), veh/ln	0.0	0.1	0.0	0.4	0.0	0.6	0.0	0.1
2nd-Term Q (Q2), veh/ln	0.0	0.0	0.0	0.0	0.0	0.1	0.0	0.0
3rd-Term Q (Q3), veh/ln	0.0	0.0	0.0	0.0	0.0	0.0	0.0	0.0
%ile Back of Q Factor (f_B%)	0.00	1.00	0.00	1.00	0.00	1.00	0.00	1.00
%ile Back of Q (50%), veh/ln	0.0	0.2	0.0	0.5	0.0	0.6	0.0	0.1
%ile Storage Ratio (RQ%)	0.00	0.00	0.00	0.00	0.00	0.03	0.00	0.00
Initial Q (Qb), veh	0.0	0.0	0.0	0.0	0.0	0.0	0.0	0.0
Final (Residual) Q (Qe), veh	0.0	0.0	0.0	0.0	0.0	0.0	0.0	0.0
Sat Delay (ds), s/veh	0.0	0.0	0.0	0.0	0.0	0.0	0.0	0.0
Sat Q (Qs), veh	0.0	0.0	0.0	0.0	0.0	0.0	0.0	0.0
Sat Cap (cs), veh/h	0	0	0	0	0	0	0	0
Initial Q Clear Time (tc), h	0.0	0.0	0.0	0.0	0.0	0.0	0.0	0.0

Intersection Summary

HCM 2010 Ctrl Delay	8.8
HCM 2010 LOS	A

Intersection

Int Delay, s/veh 1

Movement	EBL	EBT	EBR	WBL	WBT	WBR	NBL	NBT	NBR	SBL	SBT	SBR
Lane Configurations		↕	↕		↕	↕	↕	↕↕	↕	↕	↕↕	↕
Traffic Vol, veh/h	0	3	5	3	2	14	16	207	3	8	167	11
Future Vol, veh/h	0	3	5	3	2	14	16	207	3	8	167	11
Conflicting Peds, #/hr	0	0	0	0	0	0	0	0	0	0	0	0
Sign Control	Stop	Stop	Stop	Stop	Stop	Stop	Free	Free	Free	Free	Free	Free
RT Channelized	-	-	None	-	-	None	-	-	None	-	-	None
Storage Length	-	-	0	-	-	0	0	-	0	0	-	0
Veh in Median Storage, #	-	0	-	-	0	-	-	0	-	-	0	-
Grade, %	-	0	-	-	0	-	-	0	-	-	0	-
Peak Hour Factor	92	92	92	92	92	92	92	92	92	92	92	92
Heavy Vehicles, %	2	2	2	2	2	2	2	2	2	2	2	2
Mvmt Flow	0	3	5	3	2	15	17	225	3	9	182	12

Major/Minor	Minor2		Minor1		Major1		Major2					
Conflicting Flow All	348	462	91	370	471	113	194	0	0	228	0	0
Stage 1	200	200	-	259	259	-	-	-	-	-	-	-
Stage 2	148	262	-	111	212	-	-	-	-	-	-	-
Critical Hdwy	7.54	6.54	6.94	7.54	6.54	6.94	4.14	-	-	4.14	-	-
Critical Hdwy Stg 1	6.54	5.54	-	6.54	5.54	-	-	-	-	-	-	-
Critical Hdwy Stg 2	6.54	5.54	-	6.54	5.54	-	-	-	-	-	-	-
Follow-up Hdwy	3.52	4.02	3.32	3.52	4.02	3.32	2.22	-	-	2.22	-	-
Pot Cap-1 Maneuver	582	495	949	562	489	918	1377	-	-	1337	-	-
Stage 1	783	735	-	723	692	-	-	-	-	-	-	-
Stage 2	840	690	-	882	726	-	-	-	-	-	-	-
Platoon blocked, %								-	-	-	-	-
Mov Cap-1 Maneuver	562	486	949	548	480	918	1377	-	-	1337	-	-
Mov Cap-2 Maneuver	562	486	-	548	480	-	-	-	-	-	-	-
Stage 1	774	730	-	714	684	-	-	-	-	-	-	-
Stage 2	813	682	-	867	721	-	-	-	-	-	-	-

Approach	EB		WB		NB		SB	
HCM Control Delay, s	10.2		9.8		0.5		0.3	
HCM LOS	B		A					

Minor Lane/Major Mvmt	NBL	NBT	NBR	EBLn1	EBLn2	WBLn1	WBLn2	SBL	SBT	SBR
Capacity (veh/h)	1377	-	-	486	949	519	918	1337	-	-
HCM Lane V/C Ratio	0.013	-	-	0.007	0.006	0.01	0.017	0.007	-	-
HCM Control Delay (s)	7.6	-	-	12.5	8.8	12	9	7.7	-	-
HCM Lane LOS	A	-	-	B	A	B	A	A	-	-
HCM 95th %tile Q(veh)	0	-	-	0	0	0	0.1	0	-	-

Intersection												
Int Delay, s/veh	1.9											
Movement	EBL	EBT	EBR	WBL	WBT	WBR	NBL	NBT	NBR	SBL	SBT	SBR
Lane Configurations		↕	↗		↕	↗	↖	↕	↖	↖	↕	↗
Traffic Vol, veh/h	8	3	15	2	7	15	18	142	0	6	113	11
Future Vol, veh/h	8	3	15	2	7	15	18	142	0	6	113	11
Conflicting Peds, #/hr	0	0	0	0	0	0	0	0	0	0	0	0
Sign Control	Stop	Stop	Stop	Stop	Stop	Stop	Free	Free	Free	Free	Free	Free
RT Channelized	-	-	None	-	-	None	-	-	None	-	-	None
Storage Length	-	-	0	-	-	0	0	-	0	0	-	0
Veh in Median Storage, #	-	0	-	-	0	-	-	0	-	-	0	-
Grade, %	-	0	-	-	0	-	-	0	-	-	0	-
Peak Hour Factor	92	92	92	92	92	92	92	92	92	92	92	92
Heavy Vehicles, %	2	2	2	2	2	2	2	2	2	2	2	2
Mvmt Flow	9	3	16	2	8	16	20	154	0	7	123	12

Major/Minor	Minor2		Minor1		Major1		Major2					
Conflicting Flow All	258	331	62	271	343	77	135	0	0	154	0	0
Stage 1	137	137	-	194	194	-	-	-	-	-	-	-
Stage 2	121	194	-	77	149	-	-	-	-	-	-	-
Critical Hdwy	7.54	6.54	6.94	7.54	6.54	6.94	4.14	-	-	4.14	-	-
Critical Hdwy Stg 1	6.54	5.54	-	6.54	5.54	-	-	-	-	-	-	-
Critical Hdwy Stg 2	6.54	5.54	-	6.54	5.54	-	-	-	-	-	-	-
Follow-up Hdwy	3.52	4.02	3.32	3.52	4.02	3.32	2.22	-	-	2.22	-	-
Pot Cap-1 Maneuver	674	587	990	660	578	968	1447	-	-	1424	-	-
Stage 1	852	782	-	789	739	-	-	-	-	-	-	-
Stage 2	870	739	-	923	773	-	-	-	-	-	-	-
Platoon blocked, %								-	-	-	-	-
Mov Cap-1 Maneuver	646	576	990	637	567	968	1447	-	-	1424	-	-
Mov Cap-2 Maneuver	646	576	-	637	567	-	-	-	-	-	-	-
Stage 1	840	778	-	778	729	-	-	-	-	-	-	-
Stage 2	835	729	-	900	769	-	-	-	-	-	-	-

Approach	EB		WB		NB		SB			
HCM Control Delay, s	9.6		9.7		0.8		0.3			
HCM LOS	A		A							

Minor Lane/Major Mvmt	NBL	NBT	NBR	EBLn1	EBLn2	WBLn1	WBLn2	SBL	SBT	SBR
Capacity (veh/h)	1447	-	-	625	990	581	968	1424	-	-
HCM Lane V/C Ratio	0.014	-	-	0.019	0.016	0.017	0.017	0.005	-	-
HCM Control Delay (s)	7.5	-	-	10.9	8.7	11.3	8.8	7.5	-	-
HCM Lane LOS	A	-	-	B	A	B	A	A	-	-
HCM 95th %tile Q(veh)	0	-	-	0.1	0.1	0.1	0.1	0	-	-

HCM 2010 TWSC
 26: CA 7 & I-8 East Off-ramp/I-8 East On-ramp

01/07/2021

Intersection												
Int Delay, s/veh	3.8											
Movement	EBL	EBT	EBR	WBL	WBT	WBR	NBL	NBT	NBR	SBL	SBT	SBR
Lane Configurations		↔						↑↑	↑		↑	
Traffic Vol, veh/h	128	0	27	0	0	0	0	217	1	1	59	0
Future Vol, veh/h	128	0	27	0	0	0	0	217	1	1	59	0
Conflicting Peds, #/hr	0	0	0	0	0	0	0	0	0	0	0	0
Sign Control	Stop	Stop	Stop	Free	Free	Free	Free	Free	Free	Free	Free	Free
RT Channelized	-	-	None	-	-	None	-	-	None	-	-	None
Storage Length	-	-	-	-	-	-	-	-	0	-	-	-
Veh in Median Storage, #	-	0	-	-	-	-	-	0	-	-	0	-
Grade, %	-	0	-	-	0	-	-	0	-	-	0	-
Peak Hour Factor	92	92	92	92	92	92	92	92	92	92	92	92
Heavy Vehicles, %	2	2	2	2	2	2	2	2	2	2	2	2
Mvmt Flow	139	0	29	0	0	0	0	236	1	1	64	0

Major/Minor	Minor2			Major1			Major2		
Conflicting Flow All	184	303	64	-	0	0	237	0	0
Stage 1	66	66	-	-	-	-	-	-	-
Stage 2	118	237	-	-	-	-	-	-	-
Critical Hdwy	6.63	6.53	6.23	-	-	-	4.13	-	-
Critical Hdwy Stg 1	5.43	5.53	-	-	-	-	-	-	-
Critical Hdwy Stg 2	5.83	5.53	-	-	-	-	-	-	-
Follow-up Hdwy	3.519	4.019	3.319	-	-	-	2.219	-	-
Pot Cap-1 Maneuver	797	609	1000	0	-	-	1329	-	0
Stage 1	956	840	-	0	-	-	-	-	0
Stage 2	895	708	-	0	-	-	-	-	0
Platoon blocked, %									
Mov Cap-1 Maneuver	796	0	1000	-	-	-	1329	-	-
Mov Cap-2 Maneuver	796	0	-	-	-	-	-	-	-
Stage 1	956	0	-	-	-	-	-	-	-
Stage 2	894	0	-	-	-	-	-	-	-

Approach	EB	NB	SB
HCM Control Delay, s	10.5	0	0.1
HCM LOS	B		

Minor Lane/Major Mvmt	NBT	NBR	EBLn1	SBL	SBT
Capacity (veh/h)	-	-	825	1329	-
HCM Lane V/C Ratio	-	-	0.204	0.001	-
HCM Control Delay (s)	-	-	10.5	7.7	-
HCM Lane LOS	-	-	B	A	-
HCM 95th %tile Q(veh)	-	-	0.8	0	-

HCM 2010 TWSC
 26: CA 7 & I-8 East Off-ramp/I-8 East On-ramp

01/11/2021

Intersection												
Int Delay, s/veh	2.8											
Movement	EBL	EBT	EBR	WBL	WBT	WBR	NBL	NBT	NBR	SBL	SBT	SBR
Lane Configurations		↔						↑↑	↑		↑	
Traffic Vol, veh/h	49	0	52	0	0	0	0	160	9	0	78	0
Future Vol, veh/h	49	0	52	0	0	0	0	160	9	0	78	0
Conflicting Peds, #/hr	0	0	0	0	0	0	0	0	0	0	0	0
Sign Control	Stop	Stop	Stop	Free	Free	Free	Free	Free	Free	Free	Free	Free
RT Channelized	-	-	None	-	-	None	-	-	None	-	-	None
Storage Length	-	-	-	-	-	-	-	-	0	-	-	-
Veh in Median Storage, #	-	0	-	-	-	-	-	0	-	-	0	-
Grade, %	-	0	-	-	0	-	-	0	-	-	0	-
Peak Hour Factor	92	92	92	92	92	92	92	92	92	92	92	92
Heavy Vehicles, %	2	2	2	2	2	2	2	2	2	2	2	2
Mvmt Flow	53	0	57	0	0	0	0	174	10	0	85	0

Major/Minor	Minor2			Major1			Major2		
Conflicting Flow All	172	269	85	-	0	0	-	-	0
Stage 1	85	85	-	-	-	-	-	-	-
Stage 2	87	184	-	-	-	-	-	-	-
Critical Hdwy	6.63	6.53	6.23	-	-	-	-	-	-
Critical Hdwy Stg 1	5.43	5.53	-	-	-	-	-	-	-
Critical Hdwy Stg 2	5.83	5.53	-	-	-	-	-	-	-
Follow-up Hdwy	3.519	4.019	3.319	-	-	-	-	-	-
Pot Cap-1 Maneuver	810	637	973	0	-	-	0	-	0
Stage 1	938	824	-	0	-	-	0	-	0
Stage 2	927	747	-	0	-	-	0	-	0
Platoon blocked, %									
Mov Cap-1 Maneuver	810	0	973	-	-	-	-	-	-
Mov Cap-2 Maneuver	810	0	-	-	-	-	-	-	-
Stage 1	938	0	-	-	-	-	-	-	-
Stage 2	927	0	-	-	-	-	-	-	-

Approach	EB	NB	SB
HCM Control Delay, s	9.6	0	0
HCM LOS	A		

Minor Lane/Major Mvmt	NBT	NBR	EBLn1	SBT
Capacity (veh/h)	-	-	886	-
HCM Lane V/C Ratio	-	-	0.124	-
HCM Control Delay (s)	-	-	9.6	-
HCM Lane LOS	-	-	A	-
HCM 95th %tile Q(veh)	-	-	0.4	-

Intersection												
Int Delay, s/veh	1.2											
Movement	EBL	EBT	EBR	WBL	WBT	WBR	NBL	NBT	NBR	SBL	SBT	SBR
Lane Configurations					↕			↕			↑	↗
Traffic Vol, veh/h	0	0	0	4	0	5	23	94	0	0	61	35
Future Vol, veh/h	0	0	0	4	0	5	23	94	0	0	61	35
Conflicting Peds, #/hr	0	0	0	0	0	0	0	0	0	0	0	0
Sign Control	Free	Free	Free	Stop	Stop	Stop	Free	Free	Free	Free	Free	Free
RT Channelized	-	-	None	-	-	None	-	-	None	-	-	None
Storage Length	-	-	-	-	-	-	-	-	-	-	-	0
Veh in Median Storage, #	-	-	-	-	0	-	-	0	-	-	0	-
Grade, %	-	0	-	-	0	-	-	0	-	-	0	-
Peak Hour Factor	92	92	92	92	92	92	92	92	92	92	92	92
Heavy Vehicles, %	2	2	2	2	2	2	2	2	2	2	2	2
Mvmt Flow	0	0	0	4	0	5	25	102	0	0	66	38

Major/Minor	Minor1		Major1		Major2		
Conflicting Flow All	237	256	102	104	0	-	0
Stage 1	152	152	-	-	-	-	-
Stage 2	85	104	-	-	-	-	-
Critical Hdwy	6.42	6.52	6.22	4.12	-	-	-
Critical Hdwy Stg 1	5.42	5.52	-	-	-	-	-
Critical Hdwy Stg 2	5.42	5.52	-	-	-	-	-
Follow-up Hdwy	3.518	4.018	3.318	2.218	-	-	-
Pot Cap-1 Maneuver	751	648	953	1488	-	0	0
Stage 1	876	772	-	-	-	0	0
Stage 2	938	809	-	-	-	0	0
Platoon blocked, %	-	-	-	-	-	-	-
Mov Cap-1 Maneuver	737	0	953	1488	-	-	-
Mov Cap-2 Maneuver	737	0	-	-	-	-	-
Stage 1	860	0	-	-	-	-	-
Stage 2	938	0	-	-	-	-	-

Approach	WB	NB	SB
HCM Control Delay, s	9.3	1.5	0
HCM LOS	A		

Minor Lane/Major Mvmt	NBL	NBTWBLn1	SBT	SBR
Capacity (veh/h)	1488	-	843	-
HCM Lane V/C Ratio	0.017	-	0.012	-
HCM Control Delay (s)	7.5	0	9.3	-
HCM Lane LOS	A	A	A	-
HCM 95th %tile Q(veh)	0.1	-	0	-

Intersection												
Int Delay, s/veh	0.6											
Movement	EBL	EBT	EBR	WBL	WBT	WBR	NBL	NBT	NBR	SBL	SBT	SBR
Lane Configurations					↕			↕			↑	↗
Traffic Vol, veh/h	0	0	0	6	0	4	14	122	80	0	74	50
Future Vol, veh/h	0	0	0	6	0	4	14	122	80	0	74	50
Conflicting Peds, #/hr	0	0	0	0	0	0	0	0	0	0	0	0
Sign Control	Free	Free	Free	Stop	Stop	Stop	Free	Free	Free	Free	Free	Free
RT Channelized	-	-	None	-	-	None	-	-	None	-	-	None
Storage Length	-	-	-	-	-	-	-	-	-	-	-	0
Veh in Median Storage, #	-	-	-	-	0	-	-	0	-	-	0	-
Grade, %	-	0	-	-	0	-	-	0	-	-	0	-
Peak Hour Factor	92	92	92	92	92	92	92	92	92	92	92	92
Heavy Vehicles, %	2	2	2	2	2	2	2	2	2	2	2	2
Mvmt Flow	0	0	0	7	0	4	15	133	87	0	80	54

Major/Minor	Minor1		Major1		Major2		
Conflicting Flow All	314	341	177	134	0	0	-
Stage 1	207	207	-	-	-	-	-
Stage 2	107	134	-	-	-	-	-
Critical Hdwy	6.42	6.52	6.22	4.12	-	-	-
Critical Hdwy Stg 1	5.42	5.52	-	-	-	-	-
Critical Hdwy Stg 2	5.42	5.52	-	-	-	-	-
Follow-up Hdwy	3.518	4.018	3.318	2.218	-	-	-
Pot Cap-1 Maneuver	679	581	866	1451	-	-	0
Stage 1	828	731	-	-	-	-	0
Stage 2	917	785	-	-	-	-	0
Platoon blocked, %					-	-	-
Mov Cap-1 Maneuver	671	0	866	1451	-	-	-
Mov Cap-2 Maneuver	671	0	-	-	-	-	-
Stage 1	818	0	-	-	-	-	-
Stage 2	917	0	-	-	-	-	-

Approach	WB	NB	SB
HCM Control Delay, s	10	0.5	0
HCM LOS	B		

Minor Lane/Major Mvmt	NBL	NBT	NBRWBLn1	SBT	SBR
Capacity (veh/h)	1451	-	-	737	-
HCM Lane V/C Ratio	0.01	-	-	0.015	-
HCM Control Delay (s)	7.5	0	-	10	-
HCM Lane LOS	A	A	-	B	-
HCM 95th %tile Q(veh)	0	-	-	0	-

APPENDIX D : CONSTRUCTION YEAR PLUS PROJECT ANALYSIS WORKSHEETS

Intersection						
Int Delay, s/veh	0.5					
Movement	EBT	EBR	WBL	WBT	NBL	NBR
Lane Configurations						
Traffic Vol, veh/h	64	225	25	57	0	0
Future Vol, veh/h	64	225	25	57	0	0
Conflicting Peds, #/hr	0	0	0	0	0	0
Sign Control	Free	Free	Free	Free	Stop	Stop
RT Channelized	-	None	-	None	-	None
Storage Length	-	-	-	-	0	-
Veh in Median Storage, #	0	-	-	0	0	-
Grade, %	0	-	-	0	0	-
Peak Hour Factor	92	92	92	92	92	92
Heavy Vehicles, %	2	2	2	2	2	2
Mvmt Flow	70	245	27	62	0	0

Major/Minor	Major1	Major2	Minor1	Minor2	Minor3
Conflicting Flow All	0	0	315	0	309
Stage 1	-	-	-	-	193
Stage 2	-	-	-	-	116
Critical Hdwy	-	-	4.12	-	6.42
Critical Hdwy Stg 1	-	-	-	-	5.42
Critical Hdwy Stg 2	-	-	-	-	5.42
Follow-up Hdwy	-	-	2.218	-	3.518
Pot Cap-1 Maneuver	-	-	1245	-	683
Stage 1	-	-	-	-	840
Stage 2	-	-	-	-	909
Platoon blocked, %	-	-	-	-	-
Mov Cap-1 Maneuver	-	-	1245	-	668
Mov Cap-2 Maneuver	-	-	-	-	668
Stage 1	-	-	-	-	840
Stage 2	-	-	-	-	889

Approach	EB	WB	NB
HCM Control Delay, s	0	2.4	0
HCM LOS			A

Minor Lane/Major Mvmt	NBLn1	EBT	EBR	WBL	WBT
Capacity (veh/h)	-	-	-	1245	-
HCM Lane V/C Ratio	-	-	-	0.022	-
HCM Control Delay (s)	0	-	-	8	0
HCM Lane LOS	A	-	-	A	A
HCM 95th %tile Q(veh)	-	-	-	0.1	-

Intersection						
Int Delay, s/veh	7					
Movement	EBT	EBR	WBL	WBT	NBL	NBR
Lane Configurations						
Traffic Vol, veh/h	70	0	0	87	225	25
Future Vol, veh/h	70	0	0	87	225	25
Conflicting Peds, #/hr	0	0	0	0	0	0
Sign Control	Free	Free	Free	Free	Stop	Stop
RT Channelized	-	None	-	None	-	None
Storage Length	-	-	-	-	0	-
Veh in Median Storage, #	0	-	-	0	0	-
Grade, %	0	-	-	0	0	-
Peak Hour Factor	92	92	92	92	92	92
Heavy Vehicles, %	2	2	2	2	2	2
Mvmt Flow	76	0	0	95	245	27

Major/Minor	Major1	Major2	Minor1	Minor2	Minor3
Conflicting Flow All	0	0	76	0	171
Stage 1	-	-	-	-	76
Stage 2	-	-	-	-	95
Critical Hdwy	-	-	4.12	-	6.42
Critical Hdwy Stg 1	-	-	-	-	5.42
Critical Hdwy Stg 2	-	-	-	-	5.42
Follow-up Hdwy	-	-	2.218	-	3.518
Pot Cap-1 Maneuver	-	-	1523	-	819
Stage 1	-	-	-	-	947
Stage 2	-	-	-	-	929
Platoon blocked, %	-	-	-	-	-
Mov Cap-1 Maneuver	-	-	1523	-	819
Mov Cap-2 Maneuver	-	-	-	-	819
Stage 1	-	-	-	-	947
Stage 2	-	-	-	-	929

Approach	EB	WB	NB
HCM Control Delay, s	0	0	11.4
HCM LOS			B

Minor Lane/Major Mvmt	NBLn1	EBT	EBR	WBL	WBT
Capacity (veh/h)	833	-	-	1523	-
HCM Lane V/C Ratio	0.326	-	-	-	-
HCM Control Delay (s)	11.4	-	-	0	-
HCM Lane LOS	B	-	-	A	-
HCM 95th %tile Q(veh)	1.4	-	-	0	-

Intersection						
Int Delay, s/veh	0.6					
Movement	EBL	EBT	WBT	WBR	SBL	SBR
Lane Configurations	↖	↑	↗		↖	↗
Traffic Vol, veh/h	11	289	57	7	6	7
Future Vol, veh/h	11	289	57	7	6	7
Conflicting Peds, #/hr	0	0	0	0	0	0
Sign Control	Free	Free	Free	Free	Stop	Stop
RT Channelized	-	None	-	None	-	None
Storage Length	0	-	-	-	0	0
Veh in Median Storage, #	-	0	0	-	0	-
Grade, %	-	0	0	-	0	-
Peak Hour Factor	92	92	92	92	92	92
Heavy Vehicles, %	2	2	2	2	2	2
Mvmt Flow	12	314	62	8	7	8

Major/Minor	Major1	Major2	Minor2		
Conflicting Flow All	70	0	-	0	404 66
Stage 1	-	-	-	-	66 -
Stage 2	-	-	-	-	338 -
Critical Hdwy	4.12	-	-	-	6.42 6.22
Critical Hdwy Stg 1	-	-	-	-	5.42 -
Critical Hdwy Stg 2	-	-	-	-	5.42 -
Follow-up Hdwy	2.218	-	-	-	3.518 3.318
Pot Cap-1 Maneuver	1531	-	-	-	603 998
Stage 1	-	-	-	-	957 -
Stage 2	-	-	-	-	722 -
Platoon blocked, %		-	-	-	
Mov Cap-1 Maneuver	1531	-	-	-	598 998
Mov Cap-2 Maneuver	-	-	-	-	598 -
Stage 1	-	-	-	-	949 -
Stage 2	-	-	-	-	722 -

Approach	EB	WB	SB
HCM Control Delay, s	0.3	0	9.8
HCM LOS			A

Minor Lane/Major Mvmt	EBL	EBT	WBT	WBR	SBLn1	SBLn2
Capacity (veh/h)	1531	-	-	-	598	998
HCM Lane V/C Ratio	0.008	-	-	-	0.011	0.008
HCM Control Delay (s)	7.4	-	-	-	11.1	8.6
HCM Lane LOS	A	-	-	-	B	A
HCM 95th %tile Q(veh)	0	-	-	-	0	0

Intersection						
Int Delay, s/veh	0.6					
Movement	EBL	EBT	WBT	WBR	SBL	SBR
Lane Configurations	↙	↑	↘		↙	↘
Traffic Vol, veh/h	5	70	312	11	2	18
Future Vol, veh/h	5	70	312	11	2	18
Conflicting Peds, #/hr	0	0	0	0	0	0
Sign Control	Free	Free	Free	Free	Stop	Stop
RT Channelized	-	None	-	None	-	None
Storage Length	0	-	-	-	0	0
Veh in Median Storage, #	-	0	0	-	0	-
Grade, %	-	0	0	-	0	-
Peak Hour Factor	92	92	92	92	92	92
Heavy Vehicles, %	2	2	2	2	2	2
Mvmt Flow	5	76	339	12	2	20

























Major/Minor	Major1	Major2	Minor2		
Conflicting Flow All	351	0	-	0	431
Stage 1	-	-	-	-	345
Stage 2	-	-	-	-	86
Critical Hdwy	4.12	-	-	-	6.42
Critical Hdwy Stg 1	-	-	-	-	5.42
Critical Hdwy Stg 2	-	-	-	-	5.42
Follow-up Hdwy	2.218	-	-	-	3.518
Pot Cap-1 Maneuver	1208	-	-	-	581
Stage 1	-	-	-	-	717
Stage 2	-	-	-	-	937
Platoon blocked, %		-	-	-	
Mov Cap-1 Maneuver	1208	-	-	-	579
Mov Cap-2 Maneuver	-	-	-	-	579
Stage 1	-	-	-	-	714
Stage 2	-	-	-	-	937

Approach	EB	WB	SB
HCM Control Delay, s	0.5	0	10.4
HCM LOS			B

Minor Lane/Major Mvmt	EBL	EBT	WBT	WBR	SBLn1	SBLn2
Capacity (veh/h)	1208	-	-	-	579	698
HCM Lane V/C Ratio	0.004	-	-	-	0.004	0.028
HCM Control Delay (s)	8	-	-	-	11.2	10.3
HCM Lane LOS	A	-	-	-	B	B
HCM 95th %tile Q(veh)	0	-	-	-	0	0.1

HCM 2010 Signalized Intersection Capacity Analysis
 12: CA 7 & CA 98

01/11/2021

												
Movement	EBL	EBT	EBR	WBL	WBT	WBR	NBL	NBT	NBR	SBL	SBT	SBR
Lane Configurations												
Traffic Volume (veh/h)	22	26	112	28	27	8	56	186	33	169	130	42
Future Volume (veh/h)	22	26	112	28	27	8	56	186	33	169	130	42
Number	7	4	14	3	8	18	5	2	12	1	6	16
Initial Q, veh	0	0	0	0	0	0	0	0	0	0	0	0
Ped-Bike Adj (A_pbT)	1.00		1.00	1.00		1.00	1.00		1.00	1.00		1.00
Parking Bus Adj	1.00	1.00	1.00	1.00	1.00	1.00	1.00	1.00	1.00	1.00	1.00	1.00
Adj Sat Flow, veh/h/ln	1863	1863	1863	1863	1863	1863	1863	1863	1863	1863	1863	1863
Adj Flow Rate, veh/h	24	28	122	30	29	9	61	202	36	184	141	46
Adj No. of Lanes	1	1	2	1	1	1	2	2	1	1	2	1
Peak Hour Factor	0.92	0.92	0.92	0.92	0.92	0.92	0.92	0.92	0.92	0.92	0.92	0.92
Percent Heavy Veh, %	2	2	2	2	2	2	2	2	2	2	2	2
Opposing Right Turn Influence	Yes			Yes			Yes			Yes		
Cap, veh/h	693	745	1115	642	745	633	1187	1416	633	574	1416	633
HCM Platoon Ratio	1.00	1.00	1.00	1.00	1.00	1.00	1.00	1.00	1.00	1.00	1.00	1.00
Prop Arrive On Green	0.40	0.40	0.40	0.40	0.40	0.40	0.40	0.40	0.40	0.40	0.40	0.40
Ln Grp Delay, s/veh	8.6	8.3	8.7	8.7	8.3	8.2	9.1	8.8	8.5	12.3	8.6	8.6
Ln Grp LOS	A	A	A	A	A	A	A	A	A	B	A	A
Approach Vol, veh/h		174			68			299			371	
Approach Delay, s/veh		8.6			8.5			8.8			10.4	
Approach LOS		A			A			A			B	
Timer:		1	2	3	4	5	6	7	8			
Assigned Phs			2		4		6		8			
Case No			5.0		5.0		5.0		5.0			
Phs Duration (G+Y+Rc), s			22.5		22.5		22.5		22.5			
Change Period (Y+Rc), s			4.5		4.5		4.5		4.5			
Max Green (Gmax), s			18.0		18.0		18.0		18.0			
Max Allow Headway (MAH), s			4.9		4.2		4.7		4.6			
Max Q Clear (g_c+I1), s			3.9		3.2		9.2		3.1			
Green Ext Time (g_e), s			1.3		0.5		1.2		0.2			
Prob of Phs Call (p_c)			1.00		1.00		1.00		1.00			
Prob of Max Out (p_x)			0.00		0.00		0.00		0.00			
Left-Turn Movement Data												
Assigned Mvmt			5		7		1		3			
Mvmt Sat Flow, veh/h			2312		1364		1138		1232			
Through Movement Data												
Assigned Mvmt			2		4		6		8			
Mvmt Sat Flow, veh/h			3539		1863		3539		1863			
Right-Turn Movement Data												
Assigned Mvmt			12		14		16		18			
Mvmt Sat Flow, veh/h			1583		2787		1583		1583			
Left Lane Group Data												
Assigned Mvmt		0	5	0	7	0	1	0	3			
Lane Assignment												

HCM 2010 Signalized Intersection Capacity Analysis
 12: CA 7 & CA 98

01/11/2021

Lanes in Grp	0	2	0	1	0	1	0	1
Grp Vol (v), veh/h	0	61	0	24	0	184	0	30
Grp Sat Flow (s), veh/h/ln	0	1156	0	1364	0	1138	0	1232
Q Serve Time (g_s), s	0.0	0.8	0.0	0.5	0.0	5.5	0.0	0.7
Cycle Q Clear Time (g_c), s	0.0	1.9	0.0	0.9	0.0	7.2	0.0	1.1
Perm LT Sat Flow (s_l), veh/h/ln	0	1156	0	1364	0	1138	0	1232
Shared LT Sat Flow (s_sh), veh/h/ln	0	0	0	0	0	0	0	0
Perm LT Eff Green (g_p), s	0.0	18.0	0.0	18.0	0.0	18.0	0.0	18.0
Perm LT Serve Time (g_u), s	0.0	16.9	0.0	17.6	0.0	16.4	0.0	17.6
Perm LT Q Serve Time (g_ps), s	0.0	0.8	0.0	0.5	0.0	5.5	0.0	0.7
Time to First Blk (g_f), s	0.0	0.0	0.0	0.0	0.0	0.0	0.0	0.0
Serve Time pre Blk (g_fs), s	0.0	0.0	0.0	0.0	0.0	0.0	0.0	0.0
Prop LT Inside Lane (P_L)	0.00	1.00	0.00	1.00	0.00	1.00	0.00	1.00
Lane Grp Cap (c), veh/h	0	1187	0	693	0	574	0	642
V/C Ratio (X)	0.00	0.05	0.00	0.03	0.00	0.32	0.00	0.05
Avail Cap (c_a), veh/h	0	1187	0	693	0	574	0	642
Upstream Filter (I)	0.00	1.00	0.00	1.00	0.00	1.00	0.00	1.00
Uniform Delay (d1), s/veh	0.0	9.0	0.0	8.5	0.0	10.9	0.0	8.6
Incr Delay (d2), s/veh	0.0	0.1	0.0	0.1	0.0	1.5	0.0	0.1
Initial Q Delay (d3), s/veh	0.0	0.0	0.0	0.0	0.0	0.0	0.0	0.0
Control Delay (d), s/veh	0.0	9.1	0.0	8.6	0.0	12.3	0.0	8.7
1st-Term Q (Q1), veh/ln	0.0	0.2	0.0	0.2	0.0	1.7	0.0	0.2
2nd-Term Q (Q2), veh/ln	0.0	0.0	0.0	0.0	0.0	0.2	0.0	0.0
3rd-Term Q (Q3), veh/ln	0.0	0.0	0.0	0.0	0.0	0.0	0.0	0.0
%ile Back of Q Factor (f_B%)	0.00	1.00	0.00	1.00	0.00	1.00	0.00	1.00
%ile Back of Q (50%), veh/ln	0.0	0.3	0.0	0.2	0.0	2.0	0.0	0.3
%ile Storage Ratio (RQ%)	0.00	0.00	0.00	0.00	0.00	0.08	0.00	0.00
Initial Q (Qb), veh	0.0	0.0	0.0	0.0	0.0	0.0	0.0	0.0
Final (Residual) Q (Qe), veh	0.0	0.0	0.0	0.0	0.0	0.0	0.0	0.0
Sat Delay (ds), s/veh	0.0	0.0	0.0	0.0	0.0	0.0	0.0	0.0
Sat Q (Qs), veh	0.0	0.0	0.0	0.0	0.0	0.0	0.0	0.0
Sat Cap (cs), veh/h	0	0	0	0	0	0	0	0
Initial Q Clear Time (tc), h	0.0	0.0	0.0	0.0	0.0	0.0	0.0	0.0
Middle Lane Group Data								
Assigned Mvmt	0	2	0	4	0	6	0	8
Lane Assignment		T		T		T		T
Lanes in Grp	0	2	0	1	0	2	0	1
Grp Vol (v), veh/h	0	202	0	28	0	141	0	29
Grp Sat Flow (s), veh/h/ln	0	1770	0	1863	0	1770	0	1863
Q Serve Time (g_s), s	0.0	1.6	0.0	0.4	0.0	1.1	0.0	0.4
Cycle Q Clear Time (g_c), s	0.0	1.6	0.0	0.4	0.0	1.1	0.0	0.4
Lane Grp Cap (c), veh/h	0	1416	0	745	0	1416	0	745
V/C Ratio (X)	0.00	0.14	0.00	0.04	0.00	0.10	0.00	0.04
Avail Cap (c_a), veh/h	0	1416	0	745	0	1416	0	745
Upstream Filter (I)	0.00	1.00	0.00	1.00	0.00	1.00	0.00	1.00
Uniform Delay (d1), s/veh	0.0	8.6	0.0	8.2	0.0	8.4	0.0	8.2
Incr Delay (d2), s/veh	0.0	0.2	0.0	0.1	0.0	0.1	0.0	0.1
Initial Q Delay (d3), s/veh	0.0	0.0	0.0	0.0	0.0	0.0	0.0	0.0
Control Delay (d), s/veh	0.0	8.8	0.0	8.3	0.0	8.6	0.0	8.3
1st-Term Q (Q1), veh/ln	0.0	0.8	0.0	0.2	0.0	0.5	0.0	0.2

Baseline

Synchro 10 Report
 Page 2

PC ORIGINAL PKG

HCM 2010 Signalized Intersection Capacity Analysis
 12: CA 7 & CA 98

01/11/2021

2nd-Term Q (Q2), veh/ln	0.0	0.0	0.0	0.0	0.0	0.0	0.0	0.0
3rd-Term Q (Q3), veh/ln	0.0	0.0	0.0	0.0	0.0	0.0	0.0	0.0
%ile Back of Q Factor (f_B%)	0.00	1.00	0.00	1.00	0.00	1.00	0.00	1.00
%ile Back of Q (50%), veh/ln	0.0	0.8	0.0	0.2	0.0	0.6	0.0	0.2
%ile Storage Ratio (RQ%)	0.00	0.01	0.00	0.00	0.00	0.02	0.00	0.00
Initial Q (Qb), veh	0.0	0.0	0.0	0.0	0.0	0.0	0.0	0.0
Final (Residual) Q (Qe), veh	0.0	0.0	0.0	0.0	0.0	0.0	0.0	0.0
Sat Delay (ds), s/veh	0.0	0.0	0.0	0.0	0.0	0.0	0.0	0.0
Sat Q (Qs), veh	0.0	0.0	0.0	0.0	0.0	0.0	0.0	0.0
Sat Cap (cs), veh/h	0	0	0	0	0	0	0	0
Initial Q Clear Time (tc), h	0.0	0.0	0.0	0.0	0.0	0.0	0.0	0.0

Right Lane Group Data

























Assigned Mvmt	0	12	0	14	0	16	0	18
Lane Assignment		R		R		R		R
Lanes in Grp	0	1	0	2	0	1	0	1
Grp Vol (v), veh/h	0	36	0	122	0	46	0	9
Grp Sat Flow (s), veh/h/ln	0	1583	0	1393	0	1583	0	1583
Q Serve Time (g_s), s	0.0	0.6	0.0	1.2	0.0	0.8	0.0	0.2
Cycle Q Clear Time (g_c), s	0.0	0.6	0.0	1.2	0.0	0.8	0.0	0.2
Prot RT Sat Flow (s_R), veh/h/ln	0.0	0.0	0.0	0.0	0.0	0.0	0.0	0.0
Prot RT Eff Green (g_R), s	0.0	0.0	0.0	0.0	0.0	0.0	0.0	0.0
Prop RT Outside Lane (P_R)	0.00	1.00	0.00	1.00	0.00	1.00	0.00	1.00
Lane Grp Cap (c), veh/h	0	633	0	1115	0	633	0	633
V/C Ratio (X)	0.00	0.06	0.00	0.11	0.00	0.07	0.00	0.01
Avail Cap (c_a), veh/h	0	633	0	1115	0	633	0	633
Upstream Filter (I)	0.00	1.00	0.00	1.00	0.00	1.00	0.00	1.00
Uniform Delay (d1), s/veh	0.0	8.3	0.0	8.5	0.0	8.3	0.0	8.1
Incr Delay (d2), s/veh	0.0	0.2	0.0	0.2	0.0	0.2	0.0	0.0
Initial Q Delay (d3), s/veh	0.0	0.0	0.0	0.0	0.0	0.0	0.0	0.0
Control Delay (d), s/veh	0.0	8.5	0.0	8.7	0.0	8.6	0.0	8.2
1st-Term Q (Q1), veh/ln	0.0	0.3	0.0	0.5	0.0	0.3	0.0	0.1
2nd-Term Q (Q2), veh/ln	0.0	0.0	0.0	0.0	0.0	0.0	0.0	0.0
3rd-Term Q (Q3), veh/ln	0.0	0.0	0.0	0.0	0.0	0.0	0.0	0.0
%ile Back of Q Factor (f_B%)	0.00	1.00	0.00	1.00	0.00	1.00	0.00	1.00
%ile Back of Q (50%), veh/ln	0.0	0.3	0.0	0.5	0.0	0.4	0.0	0.1
%ile Storage Ratio (RQ%)	0.00	0.00	0.00	0.00	0.00	0.02	0.00	0.00
Initial Q (Qb), veh	0.0	0.0	0.0	0.0	0.0	0.0	0.0	0.0
Final (Residual) Q (Qe), veh	0.0	0.0	0.0	0.0	0.0	0.0	0.0	0.0
Sat Delay (ds), s/veh	0.0	0.0	0.0	0.0	0.0	0.0	0.0	0.0
Sat Q (Qs), veh	0.0	0.0	0.0	0.0	0.0	0.0	0.0	0.0
Sat Cap (cs), veh/h	0	0	0	0	0	0	0	0
Initial Q Clear Time (tc), h	0.0	0.0	0.0	0.0	0.0	0.0	0.0	0.0

Intersection Summary

HCM 2010 Ctrl Delay	9.4
HCM 2010 LOS	A

HCM 2010 Signalized Intersection Capacity Analysis
 12: CA 7 & CA 98

12/15/2021

												
Movement	EBL	EBT	EBR	WBL	WBT	WBR	NBL	NBT	NBR	SBL	SBT	SBR
Lane Configurations												
Traffic Volume (veh/h)	38	55	103	15	169	9	99	112	18	0	68	65
Future Volume (veh/h)	38	55	103	15	169	9	99	112	18	0	68	65
Number	7	4	14	3	8	18	5	2	12	1	6	16
Initial Q, veh	0	0	0	0	0	0	0	0	0	0	0	0
Ped-Bike Adj (A_pbT)	1.00		1.00	1.00		1.00	1.00		1.00	1.00		1.00
Parking Bus Adj	1.00	1.00	1.00	1.00	1.00	1.00	1.00	1.00	1.00	1.00	1.00	1.00
Adj Sat Flow, veh/h/ln	1863	1863	1863	1863	1863	1863	1863	1863	1863	1863	1863	1863
Adj Flow Rate, veh/h	41	60	112	16	184	10	108	122	20	0	74	71
Adj No. of Lanes	1	1	2	1	1	1	2	2	1	1	2	1
Peak Hour Factor	0.92	0.92	0.92	0.92	0.92	0.92	0.92	0.92	0.92	0.92	0.92	0.92
Percent Heavy Veh, %	2	2	2	2	2	2	2	2	2	2	2	2
Opposing Right Turn Influence	Yes			Yes			Yes			Yes		
Cap, veh/h	556	745	1115	619	745	633	1250	1416	633	160	1416	633
HCM Platoon Ratio	1.00	1.00	1.00	1.00	1.00	1.00	1.00	1.00	1.00	1.00	1.00	1.00
Prop Arrive On Green	0.40	0.40	0.40	0.40	0.40	0.40	0.40	0.40	0.40	0.00	0.40	0.40
Ln Grp Delay, s/veh	10.6	8.6	8.6	8.8	9.8	8.2	9.0	8.5	8.3	0.0	8.3	8.8
Ln Grp LOS	B	A	A	A	A	A	A	A	A		A	A
Approach Vol, veh/h		213			210			250			145	
Approach Delay, s/veh		9.0			9.6			8.7			8.6	
Approach LOS		A			A			A			A	
Timer:		1	2	3	4	5	6	7	8			
Assigned Phs			2		4		6		8			
Case No			5.0		5.0		5.0		5.0			
Phs Duration (G+Y+Rc), s			22.5		22.5		22.5		22.5			
Change Period (Y+Rc), s			4.5		4.5		4.5		4.5			
Max Green (Gmax), s			18.0		18.0		18.0		18.0			
Max Allow Headway (MAH), s			4.7		4.4		4.7		5.1			
Max Q Clear (g_c+I1), s			3.9		6.0		3.3		5.0			
Green Ext Time (g_e), s			1.0		0.6		0.5		0.8			
Prob of Phs Call (p_c)			1.00		1.00		1.00		1.00			
Prob of Max Out (p_x)			0.00		0.00		0.00		0.00			
Left-Turn Movement Data												
Assigned Mvmt			5		7		1		3			
Mvmt Sat Flow, veh/h			2402		1184		1241		1208			
Through Movement Data												
Assigned Mvmt			2		4		6		8			
Mvmt Sat Flow, veh/h			3539		1863		3539		1863			
Right-Turn Movement Data												
Assigned Mvmt			12		14		16		18			
Mvmt Sat Flow, veh/h			1583		2787		1583		1583			
Left Lane Group Data												
Assigned Mvmt		0	5	0	7	0	1	0	3			
Lane Assignment												

HCM 2010 Signalized Intersection Capacity Analysis
 12: CA 7 & CA 98

12/15/2021

Lanes in Grp	0	2	0	1	0	1	0	1
Grp Vol (v), veh/h	0	108	0	41	0	0	0	16
Grp Sat Flow (s), veh/h/ln	0	1201	0	1184	0	1241	0	1208
Q Serve Time (g_s), s	0.0	1.3	0.0	1.1	0.0	0.0	0.0	0.4
Cycle Q Clear Time (g_c), s	0.0	1.9	0.0	4.0	0.0	0.0	0.0	1.3
Perm LT Sat Flow (s_l), veh/h/ln	0	1201	0	1184	0	1241	0	1208
Shared LT Sat Flow (s_sh), veh/h/ln	0	0	0	0	0	0	0	0
Perm LT Eff Green (g_p), s	0.0	18.0	0.0	18.0	0.0	0.0	0.0	18.0
Perm LT Serve Time (g_u), s	0.0	17.4	0.0	15.0	0.0	0.0	0.0	17.1
Perm LT Q Serve Time (g_ps), s	0.0	1.3	0.0	1.1	0.0	0.0	0.0	0.4
Time to First Blk (g_f), s	0.0	0.0	0.0	0.0	0.0	0.0	0.0	0.0
Serve Time pre Blk (g_fs), s	0.0	0.0	0.0	0.0	0.0	0.0	0.0	0.0
Prop LT Inside Lane (P_L)	0.00	1.00	0.00	1.00	0.00	1.00	0.00	1.00
Lane Grp Cap (c), veh/h	0	1250	0	556	0	160	0	619
V/C Ratio (X)	0.00	0.09	0.00	0.07	0.00	0.00	0.00	0.03
Avail Cap (c_a), veh/h	0	1250	0	556	0	160	0	619
Upstream Filter (I)	0.00	1.00	0.00	1.00	0.00	0.00	0.00	1.00
Uniform Delay (d1), s/veh	0.0	8.8	0.0	10.3	0.0	0.0	0.0	8.8
Incr Delay (d2), s/veh	0.0	0.1	0.0	0.3	0.0	0.0	0.0	0.1
Initial Q Delay (d3), s/veh	0.0	0.0	0.0	0.0	0.0	0.0	0.0	0.0
Control Delay (d), s/veh	0.0	9.0	0.0	10.6	0.0	0.0	0.0	8.8
1st-Term Q (Q1), veh/ln	0.0	0.4	0.0	0.4	0.0	0.0	0.0	0.1
2nd-Term Q (Q2), veh/ln	0.0	0.0	0.0	0.0	0.0	0.0	0.0	0.0
3rd-Term Q (Q3), veh/ln	0.0	0.0	0.0	0.0	0.0	0.0	0.0	0.0
%ile Back of Q Factor (f_B%)	0.00	1.00	0.00	1.00	0.00	1.00	0.00	1.00
%ile Back of Q (50%), veh/ln	0.0	0.4	0.0	0.4	0.0	0.0	0.0	0.1
%ile Storage Ratio (RQ%)	0.00	0.01	0.00	0.00	0.00	0.00	0.00	0.00
Initial Q (Qb), veh	0.0	0.0	0.0	0.0	0.0	0.0	0.0	0.0
Final (Residual) Q (Qe), veh	0.0	0.0	0.0	0.0	0.0	0.0	0.0	0.0
Sat Delay (ds), s/veh	0.0	0.0	0.0	0.0	0.0	0.0	0.0	0.0
Sat Q (Qs), veh	0.0	0.0	0.0	0.0	0.0	0.0	0.0	0.0
Sat Cap (cs), veh/h	0	0	0	0	0	0	0	0
Initial Q Clear Time (tc), h	0.0	0.0	0.0	0.0	0.0	0.0	0.0	0.0
Middle Lane Group Data								
Assigned Mvmt	0	2	0	4	0	6	0	8
Lane Assignment		T		T		T		T
Lanes in Grp	0	2	0	1	0	2	0	1
Grp Vol (v), veh/h	0	122	0	60	0	74	0	184
Grp Sat Flow (s), veh/h/ln	0	1770	0	1863	0	1770	0	1863
Q Serve Time (g_s), s	0.0	1.0	0.0	0.9	0.0	0.6	0.0	3.0
Cycle Q Clear Time (g_c), s	0.0	1.0	0.0	0.9	0.0	0.6	0.0	3.0
Lane Grp Cap (c), veh/h	0	1416	0	745	0	1416	0	745
V/C Ratio (X)	0.00	0.09	0.00	0.08	0.00	0.05	0.00	0.25
Avail Cap (c_a), veh/h	0	1416	0	745	0	1416	0	745
Upstream Filter (I)	0.00	1.00	0.00	1.00	0.00	1.00	0.00	1.00
Uniform Delay (d1), s/veh	0.0	8.4	0.0	8.4	0.0	8.3	0.0	9.0
Incr Delay (d2), s/veh	0.0	0.1	0.0	0.2	0.0	0.1	0.0	0.8
Initial Q Delay (d3), s/veh	0.0	0.0	0.0	0.0	0.0	0.0	0.0	0.0
Control Delay (d), s/veh	0.0	8.5	0.0	8.6	0.0	8.3	0.0	9.8
1st-Term Q (Q1), veh/ln	0.0	0.5	0.0	0.4	0.0	0.3	0.0	1.5

Baseline

Synchro 10 Report
 Page 2

PC ORIGINAL PKG

HCM 2010 Signalized Intersection Capacity Analysis
 12: CA 7 & CA 98

12/15/2021

2nd-Term Q (Q2), veh/ln	0.0	0.0	0.0	0.0	0.0	0.0	0.0	0.2
3rd-Term Q (Q3), veh/ln	0.0	0.0	0.0	0.0	0.0	0.0	0.0	0.0
%ile Back of Q Factor (f_B%)	0.00	1.00	0.00	1.00	0.00	1.00	0.00	1.00
%ile Back of Q (50%), veh/ln	0.0	0.5	0.0	0.5	0.0	0.3	0.0	1.6
%ile Storage Ratio (RQ%)	0.00	0.01	0.00	0.00	0.00	0.01	0.00	0.00
Initial Q (Qb), veh	0.0	0.0	0.0	0.0	0.0	0.0	0.0	0.0
Final (Residual) Q (Qe), veh	0.0	0.0	0.0	0.0	0.0	0.0	0.0	0.0
Sat Delay (ds), s/veh	0.0	0.0	0.0	0.0	0.0	0.0	0.0	0.0
Sat Q (Qs), veh	0.0	0.0	0.0	0.0	0.0	0.0	0.0	0.0
Sat Cap (cs), veh/h	0	0	0	0	0	0	0	0
Initial Q Clear Time (tc), h	0.0	0.0	0.0	0.0	0.0	0.0	0.0	0.0

Right Lane Group Data

Assigned Mvmt	0	12	0	14	0	16	0	18
Lane Assignment		R		R		R		R
Lanes in Grp	0	1	0	2	0	1	0	1
Grp Vol (v), veh/h	0	20	0	112	0	71	0	10
Grp Sat Flow (s), veh/h/ln	0	1583	0	1393	0	1583	0	1583
Q Serve Time (g_s), s	0.0	0.3	0.0	1.1	0.0	1.3	0.0	0.2
Cycle Q Clear Time (g_c), s	0.0	0.3	0.0	1.1	0.0	1.3	0.0	0.2
Prot RT Sat Flow (s_R), veh/h/ln	0.0	0.0	0.0	0.0	0.0	0.0	0.0	0.0
Prot RT Eff Green (g_R), s	0.0	0.0	0.0	0.0	0.0	0.0	0.0	0.0
Prop RT Outside Lane (P_R)	0.00	1.00	0.00	1.00	0.00	1.00	0.00	1.00
Lane Grp Cap (c), veh/h	0	633	0	1115	0	633	0	633
V/C Ratio (X)	0.00	0.03	0.00	0.10	0.00	0.11	0.00	0.02
Avail Cap (c_a), veh/h	0	633	0	1115	0	633	0	633
Upstream Filter (I)	0.00	1.00	0.00	1.00	0.00	1.00	0.00	1.00
Uniform Delay (d1), s/veh	0.0	8.2	0.0	8.4	0.0	8.5	0.0	8.2
Incr Delay (d2), s/veh	0.0	0.1	0.0	0.2	0.0	0.4	0.0	0.0
Initial Q Delay (d3), s/veh	0.0	0.0	0.0	0.0	0.0	0.0	0.0	0.0
Control Delay (d), s/veh	0.0	8.3	0.0	8.6	0.0	8.8	0.0	8.2
1st-Term Q (Q1), veh/ln	0.0	0.1	0.0	0.4	0.0	0.6	0.0	0.1
2nd-Term Q (Q2), veh/ln	0.0	0.0	0.0	0.0	0.0	0.1	0.0	0.0
3rd-Term Q (Q3), veh/ln	0.0	0.0	0.0	0.0	0.0	0.0	0.0	0.0
%ile Back of Q Factor (f_B%)	0.00	1.00	0.00	1.00	0.00	1.00	0.00	1.00
%ile Back of Q (50%), veh/ln	0.0	0.2	0.0	0.5	0.0	0.6	0.0	0.1
%ile Storage Ratio (RQ%)	0.00	0.00	0.00	0.00	0.00	0.03	0.00	0.00
Initial Q (Qb), veh	0.0	0.0	0.0	0.0	0.0	0.0	0.0	0.0
Final (Residual) Q (Qe), veh	0.0	0.0	0.0	0.0	0.0	0.0	0.0	0.0
Sat Delay (ds), s/veh	0.0	0.0	0.0	0.0	0.0	0.0	0.0	0.0
Sat Q (Qs), veh	0.0	0.0	0.0	0.0	0.0	0.0	0.0	0.0
Sat Cap (cs), veh/h	0	0	0	0	0	0	0	0
Initial Q Clear Time (tc), h	0.0	0.0	0.0	0.0	0.0	0.0	0.0	0.0

Intersection Summary

HCM 2010 Ctrl Delay	9.0
HCM 2010 LOS	A

Intersection												
Int Delay, s/veh	0.9											
Movement	EBL	EBT	EBR	WBL	WBT	WBR	NBL	NBT	NBR	SBL	SBT	SBR
Lane Configurations		↕	↗		↕	↗	↖	↕	↗	↖	↕	↗
Traffic Vol, veh/h	0	3	13	3	2	14	16	207	3	8	324	11
Future Vol, veh/h	0	3	13	3	2	14	16	207	3	8	324	11
Conflicting Peds, #/hr	0	0	0	0	0	0	0	0	0	0	0	0
Sign Control	Stop	Stop	Stop	Stop	Stop	Stop	Free	Free	Free	Free	Free	Free
RT Channelized	-	-	None	-	-	None	-	-	None	-	-	None
Storage Length	-	-	0	-	-	0	0	-	0	0	-	0
Veh in Median Storage, #	-	0	-	-	0	-	-	0	-	-	0	-
Grade, %	-	0	-	-	0	-	-	0	-	-	0	-
Peak Hour Factor	92	92	92	92	92	92	92	92	92	92	92	92
Heavy Vehicles, %	2	2	2	2	2	2	2	2	2	2	2	2
Mvmt Flow	0	3	14	3	2	15	17	225	3	9	352	12

Major/Minor	Minor2		Minor1		Major1			Major2				
Conflicting Flow All	518	632	176	455	641	113	364	0	0	228	0	0
Stage 1	370	370	-	259	259	-	-	-	-	-	-	-
Stage 2	148	262	-	196	382	-	-	-	-	-	-	-
Critical Hdwy	7.54	6.54	6.94	7.54	6.54	6.94	4.14	-	-	4.14	-	-
Critical Hdwy Stg 1	6.54	5.54	-	6.54	5.54	-	-	-	-	-	-	-
Critical Hdwy Stg 2	6.54	5.54	-	6.54	5.54	-	-	-	-	-	-	-
Follow-up Hdwy	3.52	4.02	3.32	3.52	4.02	3.32	2.22	-	-	2.22	-	-
Pot Cap-1 Maneuver	440	396	837	489	391	918	1191	-	-	1337	-	-
Stage 1	622	619	-	723	692	-	-	-	-	-	-	-
Stage 2	840	690	-	787	611	-	-	-	-	-	-	-
Platoon blocked, %								-	-	-	-	-
Mov Cap-1 Maneuver	424	388	837	470	383	918	1191	-	-	1337	-	-
Mov Cap-2 Maneuver	424	388	-	470	383	-	-	-	-	-	-	-
Stage 1	613	615	-	713	682	-	-	-	-	-	-	-
Stage 2	812	680	-	764	607	-	-	-	-	-	-	-

Approach	EB		WB		NB			SB		
HCM Control Delay, s	10.3		10.2		0.6			0.2		
HCM LOS	B		B							

Minor Lane/Major Mvmt	NBL	NBT	NBR	EBLn1	EBLn2	WBLn1	WBLn2	SBL	SBT	SBR
Capacity (veh/h)	1191	-	-	388	837	431	918	1337	-	-
HCM Lane V/C Ratio	0.015	-	-	0.008	0.017	0.013	0.017	0.007	-	-
HCM Control Delay (s)	8.1	-	-	14.4	9.4	13.5	9	7.7	-	-
HCM Lane LOS	A	-	-	B	A	B	A	A	-	-
HCM 95th %tile Q(veh)	0	-	-	0	0.1	0	0.1	0	-	-

Intersection												
Int Delay, s/veh	1.5											
Movement	EBL	EBT	EBR	WBL	WBT	WBR	NBL	NBT	NBR	SBL	SBT	SBR
Lane Configurations		↕	↕		↕	↕	↕	↕↕	↕	↕	↕↕	↕
Traffic Vol, veh/h	8	3	15	2	7	15	26	299	0	6	113	11
Future Vol, veh/h	8	3	15	2	7	15	26	299	0	6	113	11
Conflicting Peds, #/hr	0	0	0	0	0	0	0	0	0	0	0	0
Sign Control	Stop	Stop	Stop	Stop	Stop	Stop	Free	Free	Free	Free	Free	Free
RT Channelized	-	-	None	-	-	None	-	-	None	-	-	None
Storage Length	-	-	0	-	-	0	0	-	0	0	-	0
Veh in Median Storage, #	-	0	-	-	0	-	-	0	-	-	0	-
Grade, %	-	0	-	-	0	-	-	0	-	-	0	-
Peak Hour Factor	92	92	92	92	92	92	92	92	92	92	92	92
Heavy Vehicles, %	2	2	2	2	2	2	2	2	2	2	2	2
Mvmt Flow	9	3	16	2	8	16	28	325	0	7	123	12

Major/Minor	Minor2		Minor1		Major1			Major2				
Conflicting Flow All	360	518	62	458	530	163	135	0	0	325	0	0
Stage 1	137	137	-	381	381	-	-	-	-	-	-	-
Stage 2	223	381	-	77	149	-	-	-	-	-	-	-
Critical Hdwy	7.54	6.54	6.94	7.54	6.54	6.94	4.14	-	-	4.14	-	-
Critical Hdwy Stg 1	6.54	5.54	-	6.54	5.54	-	-	-	-	-	-	-
Critical Hdwy Stg 2	6.54	5.54	-	6.54	5.54	-	-	-	-	-	-	-
Follow-up Hdwy	3.52	4.02	3.32	3.52	4.02	3.32	2.22	-	-	2.22	-	-
Pot Cap-1 Maneuver	571	460	990	486	453	853	1447	-	-	1231	-	-
Stage 1	852	782	-	613	612	-	-	-	-	-	-	-
Stage 2	759	612	-	923	773	-	-	-	-	-	-	-
Platoon blocked, %								-	-	-	-	-
Mov Cap-1 Maneuver	542	449	990	466	442	853	1447	-	-	1231	-	-
Mov Cap-2 Maneuver	542	449	-	466	442	-	-	-	-	-	-	-
Stage 1	836	777	-	601	600	-	-	-	-	-	-	-
Stage 2	721	600	-	899	768	-	-	-	-	-	-	-

Approach	EB		WB		NB			SB		
HCM Control Delay, s	10.2		10.8		0.6			0.4		
HCM LOS	B		B							

Minor Lane/Major Mvmt	NBL	NBT	NBR	EBLn1	EBLn2	WBLn1	WBLn2	SBL	SBT	SBR
Capacity (veh/h)	1447	-	-	513	990	447	853	1231	-	-
HCM Lane V/C Ratio	0.02	-	-	0.023	0.016	0.022	0.019	0.005	-	-
HCM Control Delay (s)	7.5	-	-	12.2	8.7	13.2	9.3	7.9	-	-
HCM Lane LOS	A	-	-	B	A	B	A	A	-	-
HCM 95th %tile Q(veh)	0.1	-	-	0.1	0.1	0.1	0.1	0	-	-

Intersection												
Int Delay, s/veh	5.8											
Movement	EBL	EBT	EBR	WBL	WBT	WBR	NBL	NBT	NBR	SBL	SBT	SBR
Lane Configurations		↔						↑↑	↑		↑	
Traffic Vol, veh/h	128	0	174	0	0	0	0	217	1	1	69	0
Future Vol, veh/h	128	0	174	0	0	0	0	217	1	1	69	0
Conflicting Peds, #/hr	0	0	0	0	0	0	0	0	0	0	0	0
Sign Control	Stop	Stop	Stop	Free	Free	Free	Free	Free	Free	Free	Free	Free
RT Channelized	-	-	None	-	-	None	-	-	None	-	-	None
Storage Length	-	-	-	-	-	-	-	-	0	-	-	-
Veh in Median Storage, #	-	0	-	-	-	-	-	0	-	-	0	-
Grade, %	-	0	-	-	0	-	-	0	-	-	0	-
Peak Hour Factor	92	92	92	92	92	92	92	92	92	92	92	92
Heavy Vehicles, %	2	2	2	2	2	2	2	2	2	2	2	2
Mvmt Flow	139	0	189	0	0	0	0	236	1	1	75	0

Major/Minor	Minor2			Major1			Major2		
Conflicting Flow All	195	314	75	-	0	0	237	0	0
Stage 1	77	77	-	-	-	-	-	-	-
Stage 2	118	237	-	-	-	-	-	-	-
Critical Hdwy	6.63	6.53	6.23	-	-	-	4.13	-	-
Critical Hdwy Stg 1	5.43	5.53	-	-	-	-	-	-	-
Critical Hdwy Stg 2	5.83	5.53	-	-	-	-	-	-	-
Follow-up Hdwy	3.519	4.019	3.319	-	-	-	2.219	-	-
Pot Cap-1 Maneuver	785	601	986	0	-	-	1329	-	0
Stage 1	946	831	-	0	-	-	-	-	0
Stage 2	895	708	-	0	-	-	-	-	0
Platoon blocked, %									
Mov Cap-1 Maneuver	784	0	986	-	-	-	1329	-	-
Mov Cap-2 Maneuver	784	0	-	-	-	-	-	-	-
Stage 1	946	0	-	-	-	-	-	-	-
Stage 2	894	0	-	-	-	-	-	-	-

Approach	EB	NB	SB
HCM Control Delay, s	11.4	0	0.1
HCM LOS	B		

Minor Lane/Major Mvmt	NBT	NBR	EBLn1	SBL	SBT
Capacity (veh/h)	-	-	889	1329	-
HCM Lane V/C Ratio	-	-	0.369	0.001	-
HCM Control Delay (s)	-	-	11.4	7.7	-
HCM Lane LOS	-	-	B	A	-
HCM 95th %tile Q(veh)	-	-	1.7	0	-

Intersection												
Int Delay, s/veh	2											
Movement	EBL	EBT	EBR	WBL	WBT	WBR	NBL	NBT	NBR	SBL	SBT	SBR
Lane Configurations		↔						↑↑	↑		↑	
Traffic Vol, veh/h	49	0	52	0	0	0	0	317	9	0	78	0
Future Vol, veh/h	49	0	52	0	0	0	0	317	9	0	78	0
Conflicting Peds, #/hr	0	0	0	0	0	0	0	0	0	0	0	0
Sign Control	Stop	Stop	Stop	Free	Free	Free	Free	Free	Free	Free	Free	Free
RT Channelized	-	-	None	-	-	None	-	-	None	-	-	None
Storage Length	-	-	-	-	-	-	-	-	0	-	-	-
Veh in Median Storage, #	-	0	-	-	-	-	-	0	-	-	0	-
Grade, %	-	0	-	-	0	-	-	0	-	-	0	-
Peak Hour Factor	92	92	92	92	92	92	92	92	92	92	92	92
Heavy Vehicles, %	2	2	2	2	2	2	2	2	2	2	2	2
Mvmt Flow	53	0	57	0	0	0	0	345	10	0	85	0

Major/Minor	Minor2			Major1			Major2		
Conflicting Flow All	258	440	85	-	0	0	-	-	0
Stage 1	85	85	-	-	-	-	-	-	-
Stage 2	173	355	-	-	-	-	-	-	-
Critical Hdwy	6.63	6.53	6.23	-	-	-	-	-	-
Critical Hdwy Stg 1	5.43	5.53	-	-	-	-	-	-	-
Critical Hdwy Stg 2	5.83	5.53	-	-	-	-	-	-	-
Follow-up Hdwy	3.519	4.019	3.319	-	-	-	-	-	-
Pot Cap-1 Maneuver	720	510	973	0	-	-	0	-	0
Stage 1	938	824	-	0	-	-	0	-	0
Stage 2	840	629	-	0	-	-	0	-	0
Platoon blocked, %									
Mov Cap-1 Maneuver	720	0	973	-	-	-	-	-	-
Mov Cap-2 Maneuver	720	0	-	-	-	-	-	-	-
Stage 1	938	0	-	-	-	-	-	-	-
Stage 2	840	0	-	-	-	-	-	-	-

Approach	EB	NB	SB
HCM Control Delay, s	10	0	0
HCM LOS	B		

Minor Lane/Major Mvmt	NBT	NBR	EBLn1	SBT
Capacity (veh/h)	-	-	831	-
HCM Lane V/C Ratio	-	-	0.132	-
HCM Control Delay (s)	-	-	10	-
HCM Lane LOS	-	-	B	-
HCM 95th %tile Q(veh)	-	-	0.5	-

Intersection												
Int Delay, s/veh	0.7											
Movement	EBL	EBT	EBR	WBL	WBT	WBR	NBL	NBT	NBR	SBL	SBT	SBR
Lane Configurations					↕			↕			↑	↗
Traffic Vol, veh/h	0	0	0	4	0	5	23	94	134	0	71	35
Future Vol, veh/h	0	0	0	4	0	5	23	94	134	0	71	35
Conflicting Peds, #/hr	0	0	0	0	0	0	0	0	0	0	0	0
Sign Control	Free	Free	Free	Stop	Stop	Stop	Free	Free	Free	Free	Free	Free
RT Channelized	-	-	None	-	-	None	-	-	None	-	-	None
Storage Length	-	-	-	-	-	-	-	-	-	-	-	0
Veh in Median Storage, #	-	-	-	-	0	-	-	0	-	-	0	-
Grade, %	-	0	-	-	0	-	-	0	-	-	0	-
Peak Hour Factor	92	92	92	92	92	92	92	92	92	92	92	92
Heavy Vehicles, %	2	2	2	2	2	2	2	2	2	2	2	2
Mvmt Flow	0	0	0	4	0	5	25	102	146	0	77	38

Major/Minor	Minor1	Major1	Major2				
Conflicting Flow All	321	340	175	115	0	0	-
Stage 1	225	225	-	-	-	-	-
Stage 2	96	115	-	-	-	-	-
Critical Hdwy	6.42	6.52	6.22	4.12	-	-	-
Critical Hdwy Stg 1	5.42	5.52	-	-	-	-	-
Critical Hdwy Stg 2	5.42	5.52	-	-	-	-	-
Follow-up Hdwy	3.518	4.018	3.318	2.218	-	-	-
Pot Cap-1 Maneuver	673	582	868	1474	-	-	0
Stage 1	812	718	-	-	-	-	0
Stage 2	928	800	-	-	-	-	0
Platoon blocked, %					-	-	-
Mov Cap-1 Maneuver	660	0	868	1474	-	-	-
Mov Cap-2 Maneuver	660	0	-	-	-	-	-
Stage 1	796	0	-	-	-	-	-
Stage 2	928	0	-	-	-	-	-

Approach	WB	NB	SB
HCM Control Delay, s	9.8	0.7	0
HCM LOS	A		

Minor Lane/Major Mvmt	NBL	NBT	NBRWBLn1	SBT	SBR
Capacity (veh/h)	1474	-	-	761	-
HCM Lane V/C Ratio	0.017	-	-	0.013	-
HCM Control Delay (s)	7.5	0	-	9.8	-
HCM Lane LOS	A	A	-	A	-
HCM 95th %tile Q(veh)	0.1	-	-	0	-

Intersection												
Int Delay, s/veh	2.7											
Movement	EBL	EBT	EBR	WBL	WBT	WBR	NBL	NBT	NBR	SBL	SBT	SBR
Lane Configurations					↕			↕			↑	↗
Traffic Vol, veh/h	0	0	0	6	0	4	161	132	80	0	74	50
Future Vol, veh/h	0	0	0	6	0	4	161	132	80	0	74	50
Conflicting Peds, #/hr	0	0	0	0	0	0	0	0	0	0	0	0
Sign Control	Free	Free	Free	Stop	Stop	Stop	Free	Free	Free	Free	Free	Free
RT Channelized	-	-	None	-	-	None	-	-	None	-	-	None
Storage Length	-	-	-	-	-	-	-	-	-	-	-	0
Veh in Median Storage, #	-	-	-	-	0	-	-	0	-	-	0	-
Grade, %	-	0	-	-	0	-	-	0	-	-	0	-
Peak Hour Factor	92	92	92	92	92	92	92	92	92	92	92	92
Heavy Vehicles, %	2	2	2	2	2	2	2	2	2	2	2	2
Mvmt Flow	0	0	0	7	0	4	175	143	87	0	80	54

Major/Minor	Minor1	Major1	Major2
Conflicting Flow All	644	671	187
Stage 1	537	537	-
Stage 2	107	134	-
Critical Hdwy	6.42	6.52	6.22
Critical Hdwy Stg 1	5.42	5.52	-
Critical Hdwy Stg 2	5.42	5.52	-
Follow-up Hdwy	3.518	4.018	3.318
Pot Cap-1 Maneuver	437	378	855
Stage 1	586	523	-
Stage 2	917	785	-
Platoon blocked, %			
Mov Cap-1 Maneuver	376	0	855
Mov Cap-2 Maneuver	376	0	-
Stage 1	504	0	-
Stage 2	917	0	-

Approach	WB	NB	SB
HCM Control Delay, s	12.6	3.4	0
HCM LOS	B		

Minor Lane/Major Mvmt	NBL	NBT	NBRWBLn1	SBT	SBR
Capacity (veh/h)	1451	-	-	485	-
HCM Lane V/C Ratio	0.121	-	-	0.022	-
HCM Control Delay (s)	7.8	0	-	12.6	-
HCM Lane LOS	A	A	-	B	-
HCM 95th %tile Q(veh)	0.4	-	-	0.1	-

SB 610 - Water Supply Assessment
For
VEGA SES 4 Solar Energy Storage Project

June 11, 2021

Prepared For:

Imperial Irrigation District
333 East Barioni Boulevard
Imperial, California 92251

VEGA SES 4 Solar Energy Storage Project

Contents

- **To properly update automated fields and TOC – Highlight (Select) entire WSA document and Select F9 and then select update entire table for the TOC, list of Figures and list of Tables, when prompted.**

PURPOSE OF WATER SUPPLY ASSESSMENT	6
Project Determination According to SB 610 - Water Supply Assessment	6
EXECUTIVE SUMMARY	8
PROJECT DESCRIPTION	9
Description of IID Service Area	13
Climate Factors	13
Imperial Valley Historic and Future Land and Water Uses	17
Imperial Integrated Regional Water Management Plan (October 2012)	18
IID Interim Water Supply Policy for Non-Agricultural Projects (September 2009)	20
IID Temporary Land Conversion Following Policy (May 2012)	21
IMPERIAL IRRIGATION DISTRICT’S WATER RIGHTS	22
California Law	22
Law of the River	23
IMPERIAL IRRIGATION DISTRICT WATER SUPPLY AND DEMAND	32
WATER AVAILABILITY – NORMAL YEAR	33
EXPECTED WATER AVAILABILITY – SINGLE DRY AND MULTIPLE DRY YEARS	35
Equitable Distribution Plan (EDP)	36
Water Management under Inadvertent Overrun Payback Policy (IOPP)	37
PROJECT WATER AVAILABILITY FOR A 20-YEAR PERIOD TO MEET PROJECTED DEMANDS	38
EXPECTED WATER DEMANDS FOR THE PROPOSED PROJECT	40
IID’S ABILITY TO MEET DEMANDS WITH WATER SUPPLY	41
Expanding Water Supply Portfolio	44
IID Near Term Water Supply Projections	46
IMPERIAL IRRIGATION DISTRICT FINDINGS	47
ASSESSMENT CONCLUSION	49
RESOURCES AND REFERENCES	50
ATTACHMENTS	51

Figures

Figure 1. Project Site Regional Location.....	10
Figure 2. Aerial Map of Project Vicinity	11
Figure 3. Project Layout/Site Plan	12
Figure 4. IID Imperial Unit Boundary and Canal Network.....	14
Figure 5. Major Colorado River Reservoir Storage Facilities and Basin Location Map.....	29
Figure 6. Lake Mead Water Elevation Levels 2020 visit< http://www.arachnoid.com/NaturalResources/index.html >	32
Figure 7. Lake Mead IOPP Schematic.....	37

Tables

Table 1. Climate Characteristics, Imperial, CA 100-Year Record, 1921-2020.....	15
Table 2. IID Areawide Annual Precipitation (In), (1991-2019)	15
Table 3. Monthly Mean Temperature (°F) – Imperial, CA 10-Year, 30-Year & 100-Year (2011-2020, 1991-2020, 1921-2020)	16
Table 4. Monthly Mean Rainfall (In) – Imperial, CA 10-Year, 30-Year & 100-Year (2011-2020, 1991-2020, 1921-2020)	16
Table 5. Non-Agricultural Water Demand within IID Water Service Area, 2015-2055 (KAFY)	19
Table 6. Historic and forecasted Agricultural Water Consumptive Use and Delivery Demand within IID Water Service Area, 2015-2055 (KAFY)	20
Table 7. IID System Operations Consumptive Use within IID Water Service Area and from AAC at Mesa Lateral 5 to Imperial Dam, (KAF), 2020	20
Table 8. Interim Water Supply Policy 2021 Annual Non-Agricultural Water Supply Development Fee Schedule	21
Table 9. CRWDA Annual 4.4 MAF Apportionment (Priorities 1 to 4) for California Agencies (AFY).....	27
Table 10. Unregulated Inflow to Lake Powell, Percent of Historic Average, 2000-2020.....	28
Table 11. IID Historic and Forecast Net Consumptive Use for Normal Year, Single-Dry Year and Multiple-Dry Year Water Supply, 2003-2037, et seq. (CRWDA Exhibit B)	33
Table 12. IID Annual Rainfall (In), Net Consumptive Use and Underrun/Overrun Amounts (AF), 1988-2020.....	35
Table 13. IID Inadvertent Overrun Payback to the Colorado River under the IOPP, 2012-2020.....	38
Table 14. Project Water Uses (AFY)	40
Table 15. IID System Operations Consumptive Use within IID Water Service Area and from AAC at Mesa Lateral 5 to Imperial Dam, (KAF), 2020	41
Table 16. IID Historic and Forecasted Consumptive Use vs CRWDA Exhibit B IID Net Available Consumptive Use, volumes at Imperial Dam (KAFY), 2015-2055 Next Update in 2021 thru 2020	42
Table 17. 2020 Approved Water Order, Actual CU (Decree Accounting Report) and IID Underrun, KAF at Imperial Dam	42
Table 18. IID Capital Project Alternatives and Cost (May 2009 price levels \$).....	45

Attachments

Attachment A: IID Interim Water Supply Policy for Non-Agricultural Projects

Acronyms

AF	Acre-Foot or Acre-Feet
AFY	Acre-Feet per Year
AOP	Annual Operations Plan
CAP	Central Arizona Project
CDCR	California Department of Corrections and Rehabilitation
CDPH	California Department of Public Health
CDWR	California Department of Water Resources
CEQA	California Environmental Quality Act
CRWDA	Colorado River Water Delivery Agreement
CUP	Conditional Use Permit
CVWD	Coachella Valley Water District
EDP	IID Equitable Distribution Plan
EIS	Environmental Impact Statement
ICPDS	Imperial County Planning and Development Services
ICS	Intentionally Created Surplus
IID	Imperial Irrigation District
IOPP	Inadvertent Overrun Payback Policy
ISG	Interim Surplus Guidelines
IRWMP	Integrated Regional Water Management Plan
IWSP	Interim Water Supply Policy
KAF	Thousand Acre Feet
LAFCO	Local Agency Formation Commission
LCR	Lower Colorado Region
MCI	Municipal, commercial, industrial
MGD	Million Gallons per Day
MW	Megawatt
MWD	Metropolitan Water District of Southern California
NAF	Naval Air Facility
PVID	Palo Verde Irrigation District
QSA/	Quantification Settlement Agreement and Related Agreements
TA	Transfer Agreements
SB	Senate Bill
SDCWA	San Diego County Water Authority
SNWA	Southern Nevada Water Authority
TLCFP	Temporary Land Conversion Following Policy
USBR	United States Bureau of Reclamation
USEPA	United States Environmental Protection Agency
WSA	Water Supply Assessment
CWC	California Water Code

PURPOSE OF WATER SUPPLY ASSESSMENT

This Water Supply Assessment (WSA) was prepared for the Imperial Irrigation District (Lead Agency) by ECORP Consulting, Inc., regarding the Vega SES 4, LLC VEGA SES 4 Solar Energy Storage Project (the “Applicant”). This study is a requirement of California law, specifically Senate Bill 610 (referred to as SB 610). SB 610 is an act that amended Section 21151.9 of the Public Resources Code, and Sections 10631, 10656, 10910, 10911, 10912, and 10915 of the Water Code. SB 221 is an act that amended Section 11010 of the Business and Professions Code, while amending Section 65867.5 and adding Sections 66455.3 and 66473.7 to the Government Code. SB 610 was approved by the Governor and filed with the Secretary of State on October 9, 2001, and became effective January 1, 2002.¹ SB 610 requires a lead agency, to determine that a project (as defined in CWC Section 10912) subject to California Environmental Quality Act (CEQA), to identify any public water system that may supply water for the project and to request the applicants to prepare a specified water supply assessment.

This study has been prepared pursuant to the requirements of CWC Section 10910, as amended by SB 610 (Costa, Chapter 643, Stats. 2001). The purpose of SB 610 is to advance water supply planning efforts in the State of California; therefore, SB 610 requires the Lead Agency, to identify any public water system or water purveyor that may supply water for the project and to prepare the WSA after a consultation. Once the water supply system is identified and water usage is established for construction and operations for the life of the project, the lead agency is then able to coordinate with the local water supplier and make informed land use decisions to help provide California’s cities, farms and rural communities with adequate water supplies.

Under SB 610, water supply assessments must be furnished to local governments for inclusion in any environmental documentation for certain projects (as defined in California Water Code (CWC) Section 10912 [a]) that are subject to the California Environmental Quality Act (CEQA). Due to increased water demands statewide, this water bill seeks to improve the link between information on water availability and certain land use decisions made by cities and counties. This bill takes a significant step toward managing the demand placed on California’s water supply. It provides further regulations and incentives to preserve and protect future water needs. Ultimately, this bill will coordinate local water supply and land use decisions to help provide California’s cities, farms, rural communities and industrial developments with adequate long-term water supplies. The WSA will allow the lead agency to determine whether water supplies will be sufficient to satisfy the demands of the project, in addition to existing and planned future uses.

Project Determination According to SB 610 - Water Supply Assessment

With the introduction of SB 610, any project under the California Environmental Quality Act (CEQA) shall provide a Water Supply Assessment if the project meets the definition of CWC § 10912. Water Code

¹SB 610 amended Section 21151.9 of the California Public Resources Code, and amended Sections 10631, 10656, 10910, 10911, 10912, and 10915, repealed Section 10913, and added and amended Section 10657 of the Water Code. SB 610 was approved by California Governor Gray Davis and filed with the Secretary of State on October 9, 2001.

section 10911(c) requires for that the lead agency “determine, based on the entire record, whether projected water supplies will be sufficient to satisfy the demands of the project, in addition to existing and planned future uses.” Specifically, Water Code section 10910(c)(3) states that “If the projected water demand associated with the proposed project was not accounted for in the most recently adopted urban water management plan, or the public water system has no urban water management plan, the water supply assessment for the project shall include a discussion with regard to whether the total projected water supplies, determined to be available by the city or county for the project during normal, single dry, and multiple dry water years during a 20 year projection, will meet the projected water demand associated with the proposed project, in addition to the public water system’s existing and planned future uses, including agricultural and manufacturing uses.”

After review of CWC § 10912a, and Section 10912 (a)(5)(B), it was determined that the Vega SES 4, LLC VEGA SES 4 Solar Energy Storage Project is deemed a project as it is considered an industrial use that will occupy more than 40 acres of land.

EXECUTIVE SUMMARY

Imperial Irrigation District has requested a WSA as part of the environmental review for the proposed Vega SES 4, LLC VEGA SES 4 Solar Energy Storage Project (“Project”). This study is intended for use by Imperial County Planning and Development Services in its evaluation of water supplies for existing and future land uses. The evaluation examines the following water elements:

- Water availability during a normal year
- Water availability during a single dry year, and multiple dry water years
- Water availability during a 20-year projection to meet existing demands
- Expected 20-year water demands of the Project
- Reasonably foreseeable planned future water demands to be served by the Imperial Irrigation District

The proposed Project site is located within Imperial Irrigation District’s (IID) Imperial Unit and district boundary and as such is eligible to receive water service. IID has adopted an Interim Water Supply Policy (IWSP) for Non-Agricultural Projects, from which water supplies can be contracted to serve new developments within IID’s water service area. For applications processed under the IWSP, applicants shall be required to pay a processing fee and, after IID board approval of the corresponding agreement, will be required to pay a reservation fee(s) and annual water supply development fees.

The IWSP sets aside 25,000 acre-feet annually (AFY) of IID’s Colorado River water supply to serve new non- agricultural projects. As of April 2021, a balance of 23,800 AFY remain available under the IWSP for new non-agricultural projects ensuring reasonably sufficient supplies for such projects. The proposed Project water demand of approximately 275 AF during an 18-month construction period and up to 10 AF/year for ongoing operations during the 30-year projected Project life represents 1.2% and 0.4 % of the annual unallocated supply set aside for new non-agricultural projects. Thus, the proposed Project’s estimated water demand would not affect IID’s ability to provide water to other users in IID’s water service area.

PROJECT DESCRIPTION

Vega SES 4, LLC is proposing to construct and operate a solar energy generation and storage facility on approximately 531.53 acres of private lands in the Imperial Valley in Imperial County. The Project would be located between the California/Mexico border and the All-American Canal, on the California side. It is approximately 10 miles east of Calexico in Sections 10, 11, 14, 15, and 16 of Township 17 South, Range 16 East of the San Bernardino Base and Meridian (SBB&M) of the “Bonds Corner” 7.5-minute topographic quadrangle. The Project would be located on Imperial County Assessor’s Parcel Numbers (APNs) 059-300-015-000 (approximately 301.73 acres), 059-300-017-000 (approximately 148.88 acres) and 059-290-010-000 (approximately 80.92 acres), all of which are currently owned by Tammy Cheri Slater and Jimmie R. Doyle (co-trustees of the Survivors Trust under the Doyle Family 2010 Trust dated August 13, 2010). (**Figure 1.** Site Regional Location, and **Figure 2.** Aerial View of Project Site and Vicinity). The Project would include approximately 313,600 photovoltaic solar cells, approximately 135 energy storage battery containers, and related electrical power interconnection and transmission facilities. The electrical energy produced by the Project would be conducted through the proposed 92 kilovolt (kV) generator intertie (“gen-tie”) line and delivered to the Imperial Irrigation District (IID) 92 kV “P” line. (**Figure 3.** Project Layout/Site Plan).

The solar energy storage facility involves a Conditional Use Permit from Imperial County that will allow for construction and operation of the Project over its projected 30-year duration.

Domestic water and sanitation facilities would be required during construction. These would be provided through bottled water and portable facilities. A domestic/potable water connection would not be required.

The Project will need to contract with IID to deliver up to 275 AF of untreated water during the 18-month construction phase for dust control and soil conditioning, and up to 10 AFY of untreated water during the operation phase to wash the PV modules. Untreated water would be provided via the All American Canal. It is anticipated that water would be pumped directly into water trucks from the canal.

This WSA does not include an analysis of water supply for any other ancillary uses, including temporary potable and sanitary supply during the 18-month construction period.

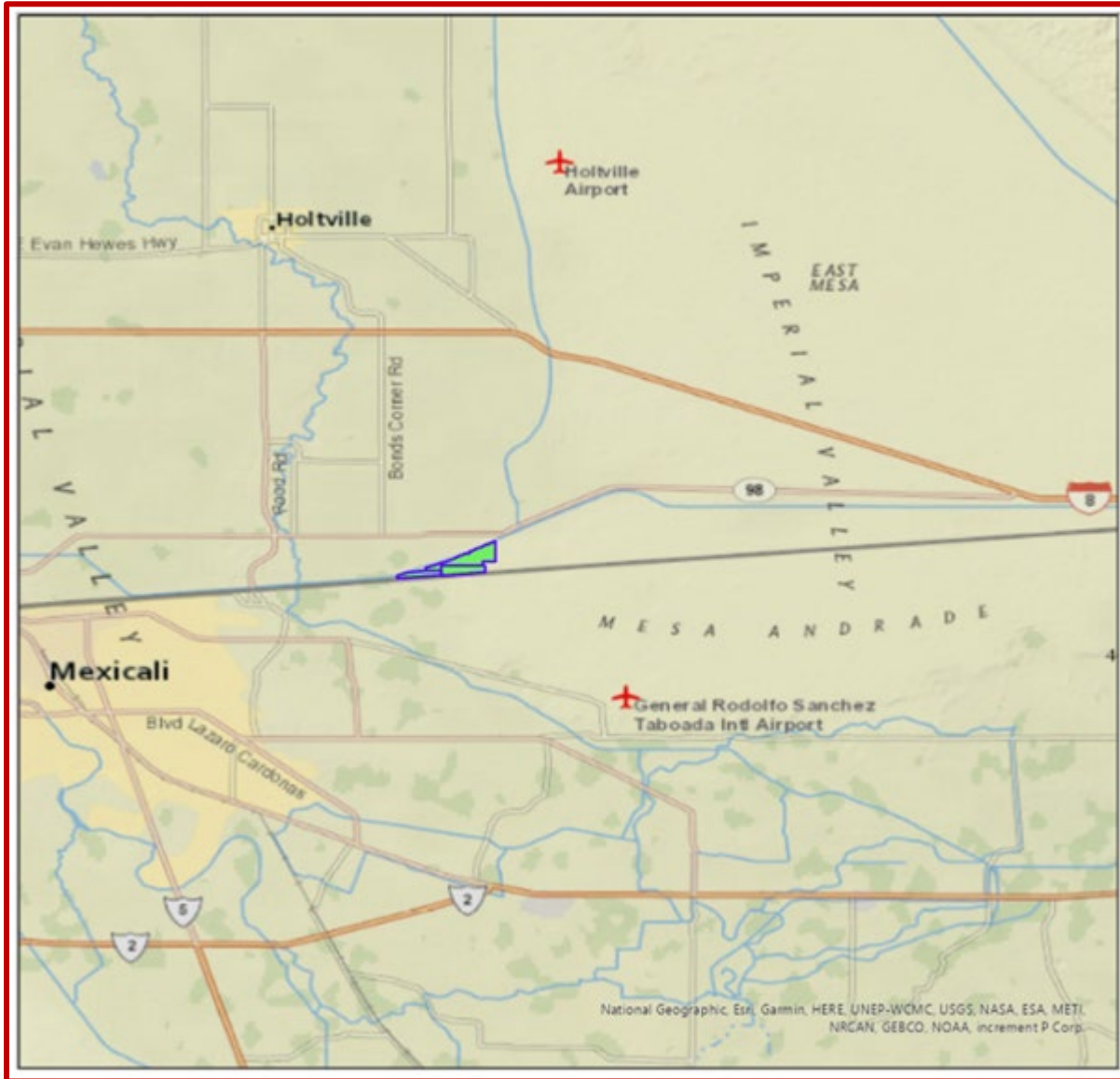


Figure 1. Project Site Regional Location

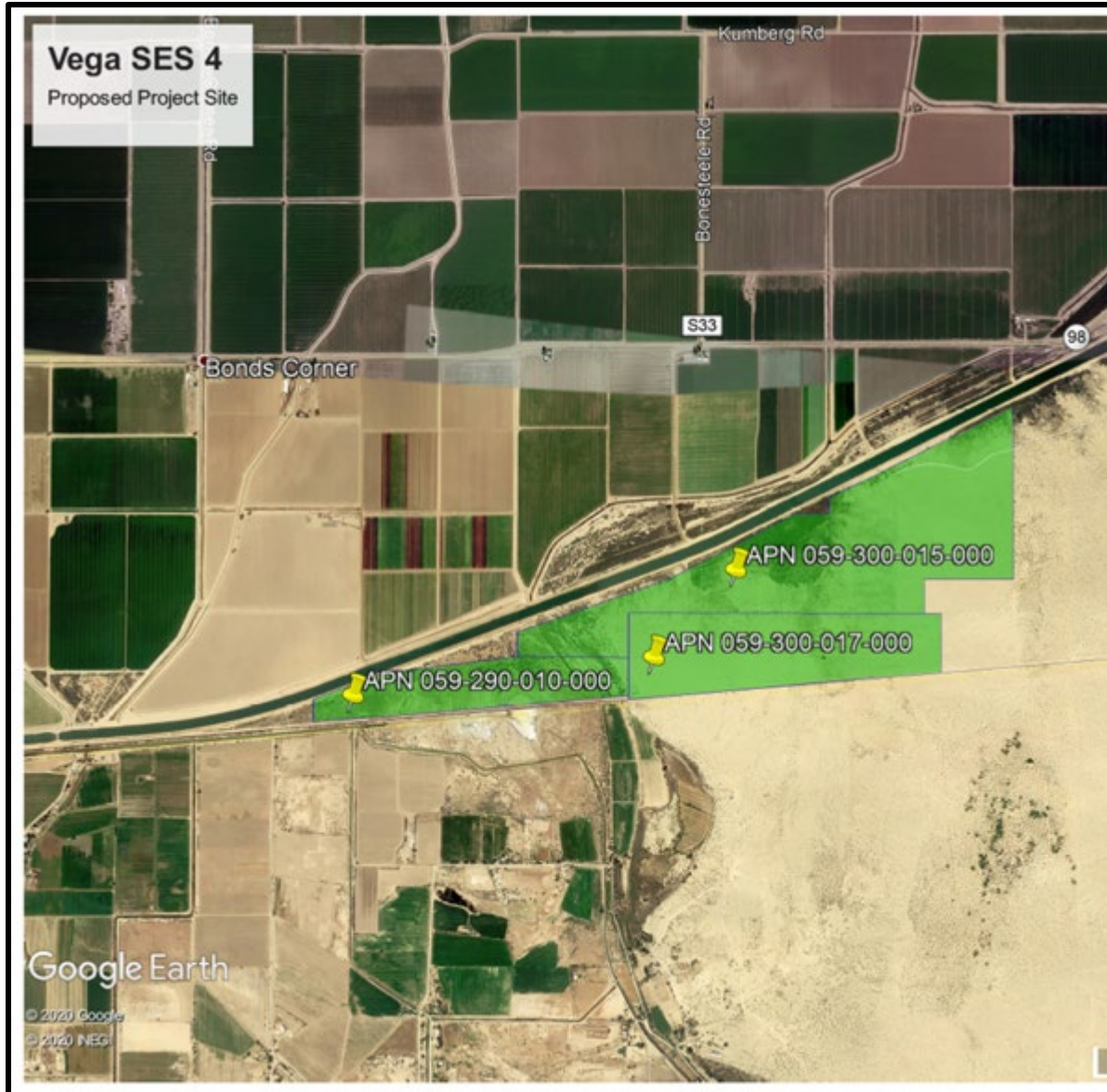


Figure 2. Aerial Map of Project Vicinity

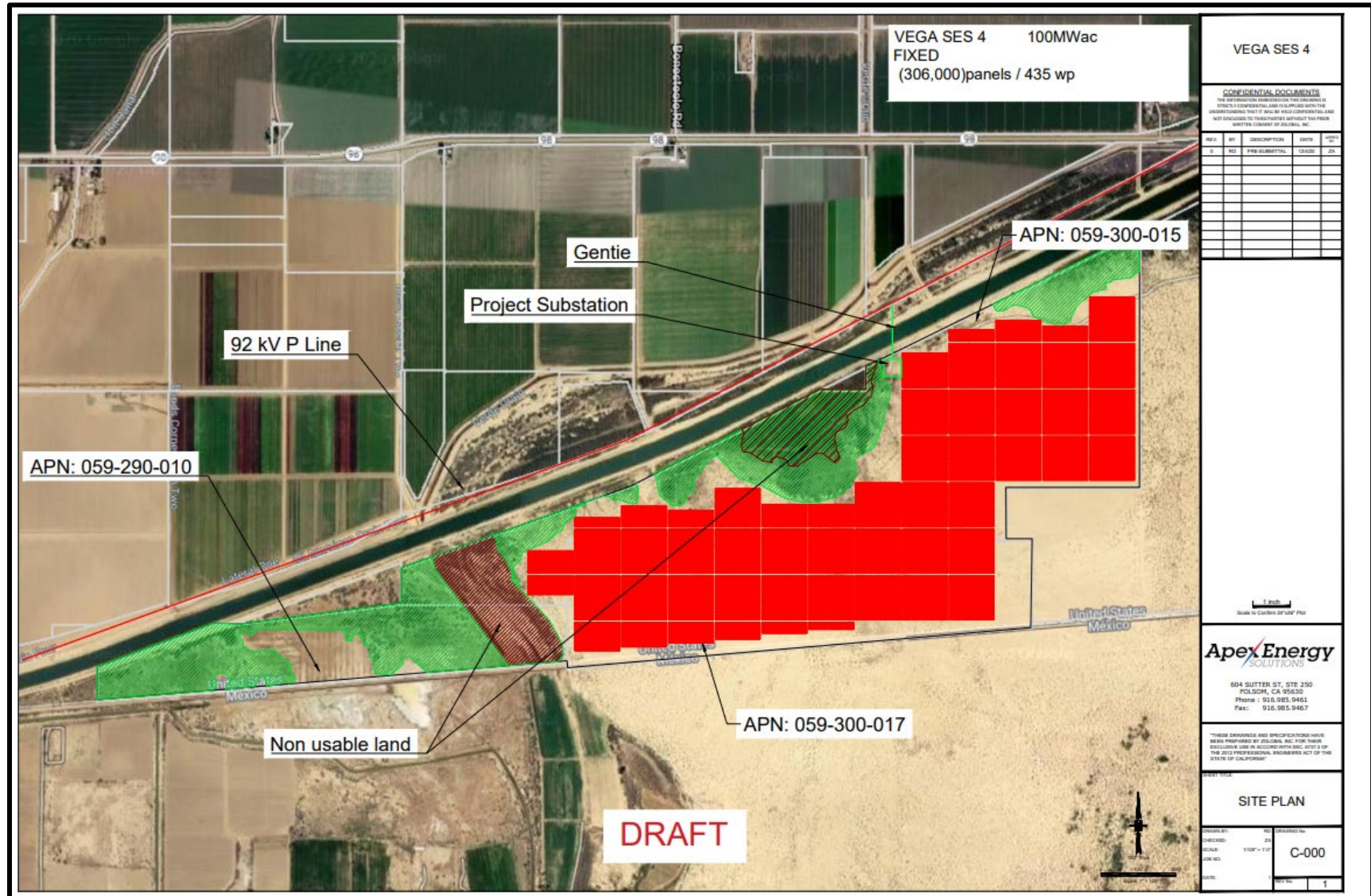


Figure 3. Project Layout/Site Plan

Description of IID Service Area

The proposed Project site is located in Imperial County in the southeastern corner of California. The County is comprised of approximately 4,597 square miles or 2,942,080 acres.² Imperial County is bordered by San Diego County to the west, Riverside County to the north, the Colorado River/Arizona boundary to the east, and 84 miles of International Boundary with the Republic of Mexico to the south. Approximately fifty percent of Imperial County is undeveloped land under federal ownership and jurisdiction. The Salton Sea accounts for approximately 11 percent of Imperial County's surface area. In 2020, sixteen percent (16%) of the area was in irrigated agriculture (466,325 acres), including 14,676 acres of the Yuma Project, some 35 sections or 5,600 acres served by Palo Verde Irrigation District (PVID), and 446,049 acres served by IID.³

The area served by IID is located in the Imperial Valley, which is generally contiguous with IID's Imperial Unit, lies south of the Salton Sea, north of the U.S./Mexico International Border, and generally in the 658,942 acre area between IID's Westside Main and East Highline Canals.⁴ In 2020, IID delivered untreated water to 494,921 net irrigated acres, predominantly in the Imperial Valley, along with small areas of East and West Mesa land.

The developed area consists of seven incorporated cities (Brawley, Calexico, Calipatria, El Centro, Holtville, Imperial and Westmorland), three unincorporated communities (Heber, Niland and Seeley), and three institutions (Naval Air Facility [NAF] El Centro, Calipatria CDCR, and Centinela CDCR) and supporting facilities. **Figure 4** provides a map of the IID Imperial Unit boundary, as well as cities, communities and main canals.

Climate Factors

Imperial Valley, located in the Northern Sonoran Desert, which has a subtropical desert climate is characterized by hot, dry summers and mild winters. Clear and sunny conditions typically prevail, and frost is rare. The region receives 85 to 90 percent of possible sunshine each year, the highest in the United States. Winter temperatures are mild rarely dropping below 32°F, but summer temperatures are very hot, with more than 100 days over 100°F each year. The remainder of the year has a relatively mild climate with temperatures averaging in the mid-70s.

The 100-year average climate characteristics are provided in **Table 1**. Rainfall contributes around 50,000 AF of effective agricultural water per inch of rain. Most rainfall occurs from November through March; however, summer storms can be significant in some years. Annual areawide rainfall is shown in **Table 2**.

² *Imperial County General Plan, Land Use Element 2008 Update*

³ *USBR website: [Yuma Project](#). 7 June 2017, PVID contact for acreage. 26 April 2021.*

⁴ *[IID Annual Inventory of Areas Receiving Water Years 2020, 2019, 2018](#)*

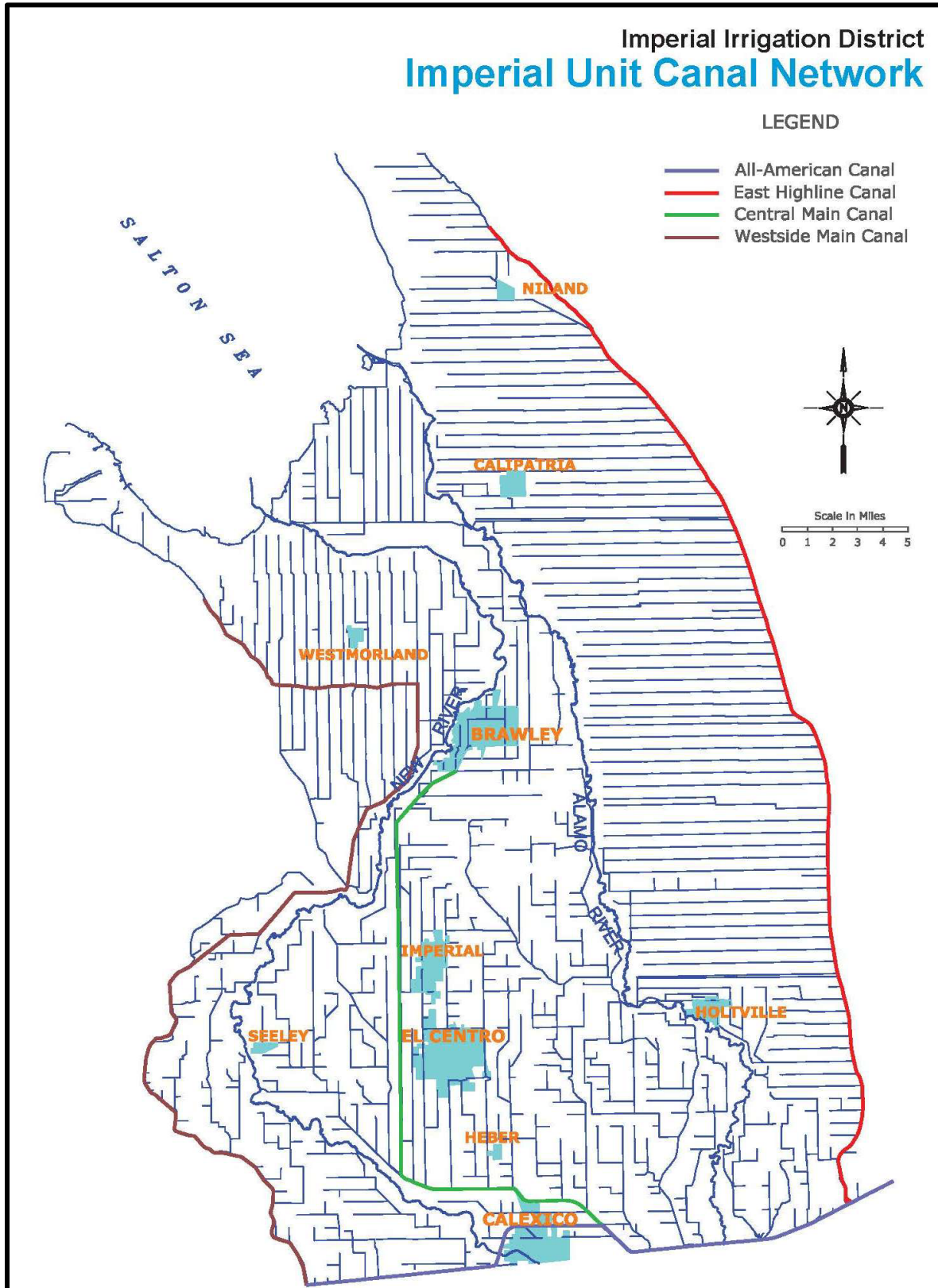


Figure 4. IID Imperial Unit Boundary and Canal Network

The thirty-year, 1991-2020, average annual air temperature was 73.7°F, and average annual rainfall was 2.70 inches, see Table 3 and Table 4. This record shows that while average annual rainfall has fluctuated, the 10-year average temperatures have slightly increased over the 30-year averages.

Table 1. Climate Characteristics, Imperial, CA 100-Year Record, 1920-2020

Climate Characteristic	Annual Value
Average Precipitation (100-year record, 1921-2020)	2.79 inches (In)
Minimum Temperature, Jan 1937	16 °F
Maximum Temperature, July 1995	121 °F
Average Minimum Temperature, 1921-2020	48.2 °F
Average Maximum Temperature, 1921-2020	98.3 °F
Average Temperature, 1921-2020	73.0 °F

Source: IID Imperial Weather Station Record

Table 2. IID Areawide Annual Precipitation (In), (1990-2020)

1990	1991	1992	1993	1994	1995	1996
1.646	3.347	4.939	2.784	1.775	1.251	0.685
1997	1998	1999	2000	2001	2002	2003
1.328	2.604	1.399	0.612	0.516	0.266	2.402
2004	2005	2006	2007	2008	2009	2010
4.116	4.140	0.410	1.331	1.301	0.619	3.907
2011	2012	2013	2014	2015	2016	2017
2.261	2.752	2.772	1.103	2.000	1.867	2.183
2018	2019	2020				
1.305	3.017	2.673				

Source: Computation based on polygon average of CIMIS as station came online in the WIS.⁵

Notable from Table 2 (above) and Table 3 (below) is that while average annual rainfall measured at IID Headquarters in Imperial, California, has been decreasing, monthly average temperatures are remarkably consistent.

⁵ From 1/1/1990-3/23/2004, 3 CIMIS stations: Seeley, Calipatria/Mulberry, Meloland; 3/24/2004-7/5/2009, 4 CIMIS stations (added Westmorland N.); 7/6/2009-12/1/2009, 3 CIMIS stations: Westmorland N. offline; 12/2/2009-2/31/2009, 4 CIMIS stations, Westmorland N. back online; 1/1/2010-9/20/2010.

Table 3. Monthly Mean Temperature (°F) – Imperial, CA 10-Year, 30-Year & 100-Year (2011-2020, 1991-2020, 1921-2020)

	Jan			Feb			Mar			Apr		
	Max	Min	Avg	Max	Min	Avg	Max	Min	Avg	Max	Min	Avg
10-year	82	32	57	84	35	60	93	42	67	100	47	73
30-year	81	34	57	84	37	60	92	41	66	99	47	71
100-year	80	31	55	86	34	60	91	40	64	99	46	71
	May			Jun			Jul			Aug		
	Max	Min	Avg	Max	Min	Avg	Max	Min	Avg	Max	Min	Avg
10-year	105	53	76	115	61	87	115	70	92	114	70	92
30-year	105	54	78	112	60	86	115	68	92	114	69	92
100-year	105	53	78	113	59	86	114	68	92	113	68	92
	Sep			Oct			Nov			Dec		
	Max	Min	Avg	Max	Min	Avg	Max	Min	Avg	Max	Min	Avg
10-year	111	62	87	101	52	76	91	39	64	80	32	55
30-year	110	62	87	102	50	76	90	39	64	79	32	55
100-year	110	60	86	101	49	75	89	38	63	80	32	56

Source: IID Imperial Headquarters Station Record (Data provided by IID staff)

Table 4. Monthly Mean Rainfall (In) – Imperial, CA 10-Year, 30-Year & 100-Year (2011-2020, 1991-2020, 1921-2020)

	Jan	Feb	Mar	Apr	May	Jun	Jul	Aug	Sep	Oct	Nov	Dec	Annual
10-year	0.33	0.26	0.22	0.12	0.08	0.01	0.22	0.30	0.28	0.02	0.26	0.42	2.44
30-year	0.50	0.43	0.31	0.09	0.06	0.00	0.14	0.19	0.26	0.15	0.22	0.40	2.70
100-year	0.39	0.38	0.25	0.11	0.03	0.00	0.12	0.33	0.36	0.25	0.21	0.51	2.79

Source: IID WIS: CIMIS stations polygon calculation (Data provided by IID staff).

Imperial Valley depends on the Colorado River for its water, which IID transports, untreated, to delivery gates for agricultural, municipal, industrial (including geothermal and solar energy), environmental (managed marsh), recreational (lakes), and other non-agricultural uses. IID supplies the cities, communities, institutions and Golden State Water (which includes all or portions Calipatria, Niland, and some adjacent Imperial County territory) with untreated water that they treat to meet state and federal drinking water guidelines before distribution to their customers. Industries outside the municipal areas treat the water to required standards of their industry. To comply with U.S. Environmental Protection Agency (USEPA) requirements and avoid termination of canal water service, residents in the IID water service area who do not receive treated water service must obtain alternative water service for drinking and cooking from a state-approved provider. To avoid penalties that could exceed \$25,000 a day, IID strictly enforces this rule. The IID Water Department tracks nearly 3,000 raw water service accounts required by the California Department of Public Health (CDPH) to have alternate state approved drinking water service. IID maintains a small-acreage pipe and drinking water database and provides an annual compliance update to CDPH.

Imperial Valley Historic and Future Land and Water Uses

Agricultural development in the Imperial Valley began at the turn of the twentieth century. In 2019, gross agricultural production for Imperial County was valued at \$2,015,843,000, of which approximately \$1,693,308,120 was produced in the IID water service area.⁶ While the agriculture-based economy is expected to continue, land use is projected to change somewhat over the years as industrial and/or alternative energy development and urbanization occur in rural areas and in areas adjacent to existing urban centers, respectively.

Imperial Valley's economy is gradually diversifying. Agriculture will likely continue to be the primary industry within the valley; however, two principal factors anticipated to reduce crop acreage are renewable energy (geothermal and solar) and urban development. Over the next twenty years, urbanization is expected to slightly decrease agriculture land use to provide space for an increase in residential, commercial and industrial uses. The transition from agricultural land use typically results in a net decrease in water demand for municipal, commercial, and solar energy development; and a net increase in water demand for geothermal energy development. Local energy resources include geothermal, wind, biomass and solar. The County General Plan provides for development of energy production centers or energy parks within Imperial County. Alternative energy facilities will help California meet its statutory and regulatory goals for increasing renewable power generation and use and decrease water demands in Imperial County.

The VEGA SES 4 Solar Storage Project is not located on land that is currently used for agriculture. Thus, the Project would not reduce agricultural production in the County. Apex Energy Solutions, LLC has identified the following additional objectives to complement the primary purpose of the Project:

- Assist California in meeting its current and future Renewable Portfolio Standard Goals.
- Site the Project in an area with excellent solar energy resources in order to maximize productivity.
- Use proven technology to reliably and economically produce electrical energy for a long period of time.
- Support greenhouse gas reduction goals of AB 32.
- Minimize environmental impacts and impacts to residential or commercial uses by locating in an area where there are few or no surrounding uses and limited potential to affect existing environment.

The IID Board has adopted the following policies and programs to address how to accommodate water demands under the terms of the QSA/ Transfers Agreements and minimize potential negative impacts on agricultural water uses:

⁶ [2019 Imperial County Crop and Livestock Report](#)

Imperial Integrated Regional Water Management Plan: adopted by the board on December 18, 2012, and by the County, the City of Imperial, to meet the basic requirement of California Department of Water Resources (CDWR) for an IRWM plan. In all, 14 local agencies adopted the 2012 Imperial IRWMP.

Interim Water Supply Policy for Non-Agricultural Projects: adopted by the board on September 29, 2009, to ensure sufficient water will be available for new development, in particular, anticipated renewable energy projects until the board selects and implements capital development projects such as those considered in the Imperial IRWMP.

Temporary Land Conversion Fallowing Policy: adopted by the board on May 8, 2012, and revised on March 29, 2016, to provide a framework for a temporary, long-term fallowing program to work in concert with the IWSP and IID's coordinated land use/water supply strategy.

Equitable Distribution Plan: adopted by the board on October 28, 2013, to provide a mechanism for IID to administer apportionment of the district's quantified annual supply of Colorado River water; the IID board approved a resolution repealing the Equitable Distribution Plan (EDP) on February 6, 2018.

In addition, water users within the IID service area are subject to the statewide requirement of reasonable and beneficial use of water under the California Constitution, Article X, section 2.

Imperial Integrated Regional Water Management Plan (October 2012)

The Imperial IRWMP serves as the governing document for regional water planning to meet present and future water resource needs and demands by addressing such issues as additional water supply options, demand management and determination and prioritization of uses and classes of service provided. In November 2012, the Imperial County Board of Supervisors approved the Imperial IRWMP, and the City of Imperial City Council and the IID Board of Directors approved it in December 2012. Approval by these three (3) stakeholders meets the basic requirement of California Department of Water Resources (CDWR) for an IRWMP. Through the IRWMP process, IID presented to the region stakeholders options in the event long-term water supply augmentation is needed, such as water storage and banking, recycling of municipal wastewater, and desalination of brackish water.⁷ As discussed herein, long term water supply augmentation is not anticipated to be necessary to meet proposed Project demands.

Chapter 5 of the 2012 Imperial IRWMP addresses water supplies (Colorado River and groundwater), demand, baseline and forecasted through 2050; and IID water budget. Chapter 12 addresses projects, programs and policies, and funding alternatives. Chapter 12 of the IRWMP lists, and Appendix N details, a set of capital projects that IID might pursue, including the amount of water that might result (AFY) and cost (\$/AF) if necessary. These also highlight potential capital improvement projects that could be implemented in the future.

⁷ October 2012 [Imperial Integrated Regional Water Management Plan](#), Chapter 12.

Imperial Valley historic 2015 and forecasted future for 2020 to 2055 non-agricultural water demand, are provided in **Table 5** in five-year increments. Total water demand for non-agricultural uses is projected to be 201.4 KAF in the year 2055. This is a forecasted increase in the use of non-agricultural water from 107.4 KAF for the period of 2015 to 2055.⁸ These values were modified from Chapter 5 of the Imperial IRWMP to reflect updated conditions from the IID Provisional Water Balance for calendar year 2015. Due to the recession in 2009 and other factors, non-agricultural growth projections have lessened since the 2012 Imperial IRWMP. Projections in **Table 5** have been adjusted (reduced by 3%) to reflect IID 2015 delivery data.

Table 5. Non-Agricultural Water Demand within IID Water Service Area, 2015-2055 (KAFY)

	2015	2020	2025	2030	2035	2040	2045	2050	2055
Municipal	30.0	30.9	36.8	39.8	41.5	46.3	51.7	57.8	61.9
Industrial	26.4	26.0	39.8	46.5	53.2	59.9	66.6	73.3	80.0
Other	5.5	6.5	5.5	5.5	5.5	5.5	5.5	5.5	5.5
Feedlots/Dairies	17.8	19.0	20.0	20.0	20.0	20.0	20.0	20.0	20.0
Envr Resources	8.3	9.2	12.0	12.0	12.0	12.0	12.0	12.0	12.0
Recreation	7.4	9.5	10.0	10.0	10.0	10.0	10.0	10.0	10.0
Service Pipes	12.0	12.0	12.0	12.0	12.0	12.0	12.0	12.0	12.0
Total Non Ag	107.4	113.1	136.1	145.8	154.2	165.7	177.8	190.6	201.4

Notes: 2015 non-agricultural water demands are from IID 2015 Provisional Water Balance rerun 03/28/2019 2020-2055 demands are modified from 2012 Imperial IRWMP Chapter 5, Table 5-22 p 5-50 based on IID 2015 Provisional Water Balance. Industrial Demand includes geothermal, but not solar, energy production. Next Update 2021

Agricultural evapotranspiration (ET) demand of approximately 1,476.4 KAF in 2015, decreased in 2020 to around 1,442.2 KAF. The termination of fallowing programs provided 103.5 KAF of water for Salton Sea mitigation in 2017. Forecasted agricultural ET remains constant, as reductions in water use are to come from efficiency conservation not reduction in agricultural production. Market forces and other factors may impact forecasted future water demand.

Table 6 provides the 2015 and 2020 historic and 2025-2055 forecasted agricultural consumptive use and delivery demand within the IID water service area. When accounting for agriculture ET, tailwater and tilewater, total agricultural consumptive use (CU) demand ranges from 2,157.9 KAF in 2015 to 2,208.5 KAF in 2055. Forecasted total agricultural delivery demand is around 1 KAFY higher than the CU demand, ranging from 2,158.9 KAF in 2015 to 2,209.5 KAF in 2055.

⁸ [Wistaria Solar Ranch, Final Environmental Impact Report](#), December 2014

Table 6. Historic and forecasted Agricultural Water Consumptive Use and Delivery Demand within IID Water Service Area, 2015-2055 (KAFY)

	2015	2020	2025	2030	2035	2040	2045	2050	2055
Ag ET from Delivered & Stored Soil Water	1,475.4	1,442.2	1,567.5	1,567.5	1,567.5	1,567.5	1,567.5	1,567.5	1,567.5
Ag Tailwater to Salton Sea	282.9	312.9	268.0	218.0	218.0	218.0	218.0	218.0	218.0
Ag Tilewater to Salton Sea	398.6	410.2	423.0	423.0	423.0	423.0	423.0	423.0	423.0
Total Ag CU Demand	2,157.9	2,165.4	2,258.5	2,208.5	2,208.5	2,208.5	2,208.5	2,208.5	2,208.5
<i>Subsurface Flow to Salton Sea</i>	<i>1.0</i>	<i>1.0</i>	<i>1.0</i>	<i>1.0</i>	<i>1.0</i>	<i>1.0</i>	<i>1.0</i>	<i>1.0</i>	<i>1.0</i>
Total Ag Delivery Demand	2,158.9	2,166.4	2,259.5	2,209.5	2,209.5	2,209.5	2,209.5	2,209.5	2,209.5

Notes: 2015 record from IID 2015 Provisional Water Balance rerun 06/28/2019; 2020-2055 forecasts from spreadsheet used to develop Figure 19, et seq. in Imperial IRWMP Chapter 5 (Data provided by IID staff). Next Update 2026

In addition to agricultural and non-agricultural water demands, system operation demand must be included to account for operational discharge, main and lateral canal seepage; and for AAC seepage, river evaporation and phreatophyte ET from Imperial Dam to IID’s measurement site at AAC Mesa Lateral 5. These system operation demands are shown in Table 7. IID measures system operational uses and at All-American Canal Station 2900 just upstream of Mesa Lateral 5 Heading. Total system operational use for 2020 was 167 KAF, including 10 KAF of LCWSP input, 39.8 KAF of seepage interception input, and 40 KAF of unaccounted canal water input.

Table 7. IID System Operations Consumptive Use within IID Water Service Area and from AAC at Mesa Lateral 5 to Imperial Dam, (KAF), 2020

Delivery System Evaporation	24.4
Canal Seepage	90.8
Canal Spill	10.1
Lateral Spill	121.5
Seepage Interception	-39.0
Unaccounted Canal Water	-40.0
Total System Operational Use, In valley	167.8
Imperial Dam to AAC @ Mesa Lat 5 (<i>Dam-Mesa Lat 5</i>)	9.2
LCWSP	-10
Total System Operational Use in 2020	167.0

Source: 2020 Water Balance rerun 01/25/2021

IID Interim Water Supply Policy for Non-Agricultural Projects (September 2009)

The IID IWSP provides a mechanism to address water supply requests for projects being developed within the IID service area. The IWSP designates up to 25,000 AFY of IID’s annual Colorado River water supply for new non-agricultural projects, provides a mechanism and process to develop a water supply agreement for any appropriately permitted project, and establishes a framework and set of fees to

ensure the supplies used to meet new demands do not adversely affect existing users by funding water conservation or augmentation projects as needed.⁹

Depending on the nature, complexity and water demands of the proposed project, new projects may be charged a one-time Reservation Fee and an annual Water Supply Development Fee for the contracted water volume used solely to assist in funding new water supply projects. The applicability of the fee to certain projects will be determined by IID on a case-by-case basis, depending on the proportion of types of land uses and water demand proposed for a project. The 2021 fee schedule is shown in Table 8.

Table 8. Interim Water Supply Policy 2021 Annual Non-Agricultural Water Supply Development Fee Schedule

Annual Demand (AF)	Reservation Fee (\$/AF)*	Development Fee (\$/AF)*
0-500	\$75.40	\$301.59
501-1000	\$106.16	\$424.64
1001-2500	\$133.30	\$533.22
2501-5000	\$164.67	\$658.68

Adjusted annually in accordance with the Consumer Price Index (CPI).

IID customers with new projects receiving water under the IWSP will be charged the appropriate water rate based on measured deliveries, see [IID Water Rate Schedules](#). As of January 2021, IID has issued one Water Supply Agreement for 1,200 AFY, leaving a balance of 23,800 AFY of supply available for contracting under the IWSP.

IID Temporary Land Conversion Following Policy (May 2012)

Imperial County planning officials determined that renewable energy facilities were consistent with the county’s agricultural zoning designation and began issuing CUPs for these projects with ten- to twenty-year terms. These longer-term, but temporary, land use designations were not conducive to a coordinated land use/water supply policy as envisioned in the Imperial IRWMP, because temporary water supply assignments during a conditional use permit (CUP) term were not sufficient to meet the water supply verification requirements for new project approvals. Agricultural land owners also sought long-term assurances from IID that, at project termination, irrigation service would be available for them to resume their farming operations.

Based on these conditions, IID determined it had to develop a water supply policy that conformed to the local land use decision-making in order to facilitate new development and economic diversity in Imperial County which has resulted in the IID Temporary Land Conversion Following Policy (TLCFP).¹⁰ IID concluded that certain lower water use projects could still provide benefits to local water users. The resulting benefits; however, may not be to the same categories of use (e.g., MCI) but to the district as a whole.

⁹ IID website: [Municipal, Industrial and Commercial Customers](#).

¹⁰ IID website: [Temporary Land Conversion Following Policy \(TLCFP\)](#), and The [TLCFP](#) are the sources of the text for this section.

At the general manager's direction, staff developed a framework for a fallowing program that could be used to supplement the IWSP and meet the multiple policy objectives envisioned for the coordinated land use/water supply strategy. Certain private projects that, if implemented, will temporarily remove land from agricultural production within the district's water service area include renewable solar energy and other non-agricultural projects. Such projects may need a short-term water supply for construction and decommissioning activities and longer-term water service for facility operation and maintenance or for treating to potable water standards. Conserved water will be credited to the extent that water use for the project is less than historic water use for the project site's footprint as determined by the ten year water use history.¹¹

Water demands for certain non-agricultural projects are typically less than that required for agricultural production; this reduced demand allows water to be made available for other users under IID's annual consumptive use cap. This allows the district to avail itself of the ability during the term of the QSA/Transfer Agreements under [CWC Section 1013](#) to create conserved water through projects such as temporary land fallowing conservation measures. This conserved water can then be used to satisfy the district's conserved water transfer obligation and for environmental mitigation purposes.

Under the terms of the legislation adopted to facilitate the QSA/Transfer Agreements and enacted in [CWC Section 1013](#), the [TLCFP](#) was adopted by the IID board on May 8, 2012 and revised on March 29, 2016 to update the fee schedule for 2016. This policy provides a framework for a temporary, long-term fallowing program to work in concert with the IWSP. While conserved water generated from the TLCFP is limited by law for use for water transfer or environmental purposes, by satisfying multiple district objectives the TLCFP serves to reduce efficiency conservation and water use reduction demands on IID water users, thus providing district wide benefits.

IMPERIAL IRRIGATION DISTRICT'S WATER RIGHTS

The laws and regulations that influence IID's water supply are noted in this section. The Law of the River (as described below), along with the 2003 Quantification Settlement Agreement and Related Agreements serve as the laws, regulations and agreements that primarily influence the findings of this WSA. These agreements grant California the most senior water rights along the Colorado River and IID specify that IID has access to 3.1 MAF per year. These two components will influence future decisions in terms of water supply during periods of shortages.

California Law

IID's has a longstanding right to divert Colorado River water, and IID holds legal titles to all of its water and water rights in trust for landowners within the district (CWC §20529 and §22437; *Bryant v. Yellen*,

¹¹ For details of how water conservation yield attributable to land removed from agricultural production and temporarily fallowed is computed, see [TLCFP for Water Conservation Yield](#).

447 U.S. 352, 371 (1980), fn.23.). Beginning in 1885, a number of individuals, as well as the California Development Company, made a series of appropriations of Colorado River water under California law for use in the Imperial Valley. The rights to these appropriations were among the properties acquired by IID from the California Development Company.

Law of the River

Colorado River water rights are governed by numerous compacts, state and federal laws, court decisions and decrees, contracts, and regulatory guidelines collectively known as the “Law of the River.” Together, these documents form the basis for allocation of the water, regulation of land use, and management of the Colorado River water supply among the seven basin states and Mexico.

Of all regulatory literature that governs Colorado River water rights, the following are the specifics that impact IID:

- Colorado River Compact (1922)
- Boulder Canyon Project Act (1928)
- California Seven-Party Agreement (1931)
- Arizona v. California US Supreme Court Decision (1964, 1979)
- Colorado River Basin Project Act (1968)
- Quantification Settlement Agreement and Related Agreements (2003)
- 2003 Colorado River Water Delivery Agreement: Federal QSA for purposes of Section 5(b) Interim Surplus Guidelines (CRWDA)
- 1970 Criteria for Coordinated Long-Range Operation of Colorado River Reservoirs
- Annual Operating Plan (AOP) for Colorado River Reservoirs
- 2007 Colorado River Interim Guidelines for Lower Basin Shortages and Coordinated Operations for Lakes Powell and Mead (2007 Interim Guidelines)

Colorado River Compact (1922)

With authorization of their legislatures and urging of the federal government, representatives from the seven Colorado River basin states began negotiations regarding distribution of water from the Colorado River in 1921. In November 1922, an interstate agreement called the “Colorado River Compact” was signed by the representatives giving the Lower Basin perpetual rights to annual apportionments of 7.5 million acre-feet (MAF) of Colorado River water (75 MAF over ten years). The Upper Basin was to receive the remainder, which based on the available hydrological record was also expected to be 7.5 MAF annually, with enough left over to provide 1.5 MAF annually to Mexico.

Boulder Canyon Project Act (1928)

Provisions in the 1928 Boulder Canyon Project Act made the compact effective and authorized construction of Hoover Dam and the All-American Canal, and served as the United States’ consent to accept the Compact. Through a Presidential Proclamation on June 25, 1929, this act resulted in

ratification of the Compact by six of the basin states and required California to limit its annual consumptive use to 4.4 MAF of the lower basin's apportionment plus not less than half of any excess or surplus water unapportioned by the Compact. A lawsuit was filed by the State of Arizona after its refusal to sign. Through the implementation of its 1929 Limitation Act, California abided by this federal mandate. The Boulder Canyon Act authorized the Secretary of the Interior (Secretary) to "contract for the storage of water... and for the delivery thereof... for irrigation and domestic uses," and additionally defined the lower basin's 7.5 MAF apportionment split, with an annual allocation 0.3 MAF to Nevada, 2.8 MAF to Arizona, and 4.4 MAF to California. Even though the three states never formally settled or agreed to these terms, a 1964 Supreme Court decision (*Arizona v. California*, 373 U.S. 546) declared the three states' consent to be insignificant since the Boulder Canyon Project Act was authorized by the Secretary.

California Seven-Party-Agreement (1931)

Following implementation of the Boulder Canyon Project Act, the Secretary requested that California make recommendations regarding distribution of its apportionment of Colorado River water. In August 1931, under chairmanship of the State Engineer, the California Seven-Party Agreement was developed and authorized by the affected parties to prioritize California water rights. The Secretary accepted this agreement and established these priorities through General Regulations issued in September of 1931. The first four (4) priority allocations account for California's annual apportionment of 4.4 MAF, with agricultural entities using 3.85 MAF of that total. Additional priorities are defined for years in which the Secretary declares that excess waters are available.

Arizona v. California U.S. Supreme Court Decision (1964, 1979)

The 1964 Supreme Court decision settled a 25-year disagreement between Arizona and California that stemmed from Arizona's desire to build the Central Arizona Project to enable use of its full apportionment. California's argument was that as Arizona used water from the Gila River, which is a Colorado River tributary, it was using a portion of its annual Colorado River apportionment. An additional argument from California was that it had developed a historical use of some of Arizona's apportionment, which, under the doctrine of prior appropriation, precluded Arizona from developing the project. California's arguments were rejected by the U.S. Supreme Court. Under direction of the Supreme Court, the Secretary was restricted from delivering water outside of the framework of apportionments defined by law. Preparation of annual reports documenting consumptive use of water in the three lower basin states was also mandated by the Supreme Court. In 1979, present perfected water rights (PPRs) referred to in the Colorado River Compact and in the Boulder Canyon Project Act were addressed by the Supreme Court in the form of a Supplemental Decree.

In March of 2006, a Consolidated Decree was issued by the Supreme Court to provide a single reference to the conditions of the original 1964 decrees and several additional decrees in 1966, 1979, 1984 and 2000 that stemmed from the original ruling. The Consolidated Decree also reflects the settlements of the federal reserved water rights claim for the Fort Yuma Indian Reservation.

Colorado River Basin Project Act (1968)

In 1968, various water development projects in both the upper and lower basins, including the Central Arizona Project (CAP) were authorized by Congress. Under the Colorado River Basin Project Act, priority was given to California's apportionment over (before) the CAP water supply in times of shortage. Also under the act, the Secretary was directed to prepare long-range criteria for the Colorado River reservoir system in consultation with the Colorado River Basin States.

Quantification Settlement Agreement and Related Agreements (2003)

With completion of a large portion of the CAP infrastructure in 1994, creation of the Arizona Water Banking Authority in 1995, and the growth of Las Vegas in the 1990s, California encountered increasing pressure to live within its rights under the Law of the River. After years of negotiating among Colorado River Compact States and affected California water delivery agencies, a Quantification Settlement Agreement and Related Agreements and documents were signed on October 10, 2003, by the Secretary of Interior, IID, Coachella Valley Water District (CVWD), Metropolitan Water District of Southern California (MWD), San Diego County Water Authority (SDCWA), and other affected parties.

The Quantification Settlement Agreement and Related Agreements (QSA/Transfer Agreements) are a set of interrelated contracts that resolve certain disputes among the United States, the State of California, IID, MWD, CVWD and SDCWA, for a period of 35 to 75 years, regarding the reasonable and beneficial use of Colorado River water; the ability to conserve, transfer and acquire conserved Colorado River water; the quantification and priority of Priorities 3(a) and 6(a)¹² within California for use of Colorado River water; and the obligation to implement and fund environmental impact mitigation.

Conserved water transfer agreements between IID and SDCWA, IID and CVWD, and IID and MWD are all part of the QSA/Transfer Agreements. For IID, these contracts identify conserved water volumes and establish transfer schedules along with price and payment terms. As specified in the agreements, IID will transfer nearly 415,000 AF annually over a 35-year period (or longer), as follows:

- to MWD 110,000 AF [modified to 105,000 AF in 2007],
- to SDCWA 200,000 AF,
- to CVWD and MWD combined 103,000 AF, and
- to certain San Luis Rey Indian Tribes 11,500 AFY of water.

All of the conserved water will ultimately come from IID system and on-farm efficiency conservation improvements. In the interim, IID has implemented a Following Program to generate water associated with Salton Sea mitigation related to the impacts of the IID/SDCWA water transfer, as required by the State Water Resources Control Board, which is to run from 2003 through 2017. In return for its QSA/Transfer Agreements programs and deliveries, IID will receive payments totaling billions of dollars

¹² Priorities 1, 2, 3(b), 6(b), and 7 of current Section 5 Contracts for the delivery of Colorado River water in the State of California and Indian and miscellaneous Present Perfected Rights within the State of California and other existing surplus water contracts are not affected by the QSA Agreement.

to fund needed efficiency conservation measures and to pay growers for conserved on-farm water, so IID can transfer nearly 14.5 MAF of water without impacting local productivity. In addition, IID will transfer to SDCWA 67,700 AFY annually of water conserved from the lining of the AAC in exchange for payment of lining project costs and a grant to IID of certain rights to use the conserved water. In addition to the 105,000 acre-feet of water currently being conserved under the 1988 IID/MWD Conservation Program, these more recent agreements define an additional 303,000 AFY to be conserved by IID from on-farm and distribution system conservation projects for transferred to SDCWA, CVWD, and MWD.

Colorado River Water Delivery Agreement (2003)¹³

As part of QSA/Transfer Agreements among California and federal agencies, the Colorado River Water Delivery Agreement: Federal QSA for purposes of Section 5(b) Interim Surplus Guidelines (CRWDA) was entered into by the Secretary of the Interior, IID, CVWD, MWD and SDCWA. This agreement involves the federal government because of the change in place of diversion from Imperial Dam into the All-American Canal to Parker Dam into MWD's Colorado River Aqueduct.

The CRWDA assists California to meet its "4.4 Plan" goals by quantifying deliveries for a specific number of years for certain Colorado River entitlements so transfers may occur. In particular, for the term of the CRWDA, quantification of Priority 3(a) was effected through caps on water deliveries to IID (consumptive use of 3.1 MAF per year) and CVWD (consumptive use of 330 KAF per year). In addition, California's Priority 3(a) apportionment between IID and CVWD, with provisions for transfer of supplies involving IID, CVWD, MWD and SDCWA are quantified in the CRWDA for a period of 35 years or 45 years (assumes SDCWA does not terminate in year 35) or 75 years (assumes SDCWA and IID mutually consent to renewal term of 30 years).

Allocations for consumptive use of Colorado River water by IID, CVWD and MWD that will enable California to stay within its basic annual apportionment (4.4 MAF plus not less than half of any declared surplus) are defined by the terms of the QSA/Transfer Agreements (**Table 9**). As specified in the QSA/Transfer Agreements, by 2026, IID annual use within (Imperial Valley) is to be reduced to just over 2.6 MAF of its 3.1 MAF quantified annual apportionment. The remaining nearly 500,000 AF (which includes the 67,000 AF from AAC lining) are to be transferred annually to urban water users outside of the Imperial Valley.

¹³ [CRWDA: Federal QSA](#) accessed 7 June 2017.

Table 9. CRWDA Annual 4.4 MAF Apportionment (Priorities 1 to 4) for California Agencies (AFY)

User	Apportionment (AFY)
Palo Verde Irrigation District and Yuma Project*	420,000
Imperial Irrigation District	3,100,000
Coachella Valley Water District	330,000
Metropolitan Water District of Southern California*	550,000
Total:	4,400,000

* PVID and Yuma Project did not agree to a cap; value represents a contractual obligation by MWD to assume responsibility for any overages or be credited with any volume below this value.

Notes: All values are consumptive use at point of Colorado River diversion: Palo Verde Diversion Dam (PVID), Imperial Dam (IID and CVWD), and Parker Dam (MWD). Source: IID Annual Water Report

Quantification of Priority 6(a) was effected through quantifying annual consumptive use amounts to be made available in order of priority to MWD (38 KAF), IID (63 KAF), and CVWD (119 KAF) with the provision that any additional water available to Priority 6(a) be delivered under IID’s and CVWD’s existing water delivery contract with the Secretary¹⁴ The CRWDA provides that the underlying water delivery contract with the Secretary remain in full force and effect. (*Colorado River Documents 2008*, Chapter 6, pages 6-12 and 6-13). The CRWDA also provides a source of water to effect a San Luis Rey Indian Water rights settlement. Additionally, the CRWDA satisfies the requirement of the 2001 Interim Surplus Guidelines (ISG) that a QSA be adopted as a prerequisite to the interim surplus determination by the Secretary in the ISG.

Inadvertent Overrun Payback Policy (2003)

The CRWDA Inadvertent Overrun Payback Policy (IOPP), adopted by the Secretary contemporaneously with the execution of the CRWDA, provides additional flexibility to Colorado River management and applies to entitlement holders in the Lower Division States (Arizona, California and Nevada)¹⁵ The IOPP defines inadvertent overruns as “Colorado River water diverted, pumped, or received by an entitlement holder of the Lower Division States that is in excess of the water users’ entitlement for the year.” An entitlement holder is allowed a maximum overrun of 10 percent (10%) of its Colorado River water entitlement.

In the event of an overrun, the IOPP provides a mechanism to payback the overrun. When the Secretary has declared a normal year for Colorado River diversions, a contractor has from one to three years to pay back its obligation, with a minimum annual payback equal to 20 percent of the entitlement holder’s maximum allowable cumulative overrun account or 33.3 percent of the total account balance, whichever is greater. However, when Lake Mead is below 1125 feet on January 1, the terms of the IOPP require that the payment of the inadvertent overrun obligation be made in the calendar year after the overrun is reported in the USBR Lower Colorado Region Colorado River Accounting and Water Use Report [for] Arizona, California, and Nevada (Decree Accounting Report).¹⁶

¹⁴ When water levels in the Colorado River reservoirs are low, Priority 5, 6 and 7 apportionments are not available for diversion.

¹⁵ USBR, 2003 CRWDA ROD Implementation Agreement, IOPP and Related Federal Actions Final EIS. Section IX. Implementing the Decision A. Inadvertent Overrun and Payback Policy. Pages 16-19 of 34.

¹⁶ 2003 [CRWDA ROD](#). Section IX. A.6.c., page 18 of 34.

1970 Criteria for Coordinated Long-Range Operation of Colorado River Reservoirs

The 1970 Operating Criteria control operation of the Colorado River reservoirs in compliance with requirements set forth in the Colorado River Compact of 1922, the United States-Mexico Water Treaty of 1944, the Colorado River Storage Project Act of 1956, the Boulder Canyon Projects Act (Lake Mead) and the Colorado River Basin Project Act (Upper Basin Reservoirs) of 1968, and other applicable federal laws. Under these Operating Criteria, the Secretary makes annual determinations published in the USBR Annual Operating Plan for Colorado River Reservoirs (discussed below) regarding the release of Colorado River water for deliveries to the lower basin states. A requirement to equalize active storage between Lake Powell and Lake Mead when there is sufficient storage in the Upper Basin is included in these operating criteria. **Figure 5** identifies the major storage facilities at the upper and lower basin boundaries.

Annual Operating Plan for Colorado River Reservoirs (Applicable Only if Lake Mead Surplus/Shortage)

The AOP is developed in accordance with Section 602 of the Colorado River Basin Project Act (Public Law 90-537); the Criteria for Coordinated Long-Range Operations of Colorado River Reservoirs Pursuant to the Colorado River Basin Project Act of 1968, as amended, promulgated by the Secretary of the Interior; and Section 1804(c)(3) of the Grand Canyon Protection Act (Public Law 102-575). As part of the AOP process, the Secretary makes determinations regarding the availability of Colorado River water for deliveries to the lower basin states, including whether normal, surplus, and shortage conditions are in effect on the lower portion of the Colorado River.

2007 Colorado River Interim Guidelines for Lower Basin Shortages (2007 Interim Guidelines)

A multi-year drought in the Colorado River Upper Basin triggered the need for the 2007 Interim Shortage Guidelines. In the summer of 1999, Lake Powell was essentially full of reservoir storage at 97 percent of capacity. However, precipitation fell off starting in October 1999 and 2002 inflow was the lowest recorded since Lake Powell began filling in 1963.¹⁷ By August 2011, inflow was 279 percent (279%) of average; however, drought resumed in 2012 and continued through calendar year 2020. Using the record in **Table 10**, average unregulated inflow to Lake Powell for water years 2000-2020 is 75.47 percent (75.5%); or if 2011 is excluded, 72.45 percent (72.5%) of the historic average.

Table 10. Unregulated Inflow to Lake Powell, Percent of Historic Average, 2000-2019

2000	2001	2002	2003	2004	2005	2006	2007	2008	2009	2010
62%	59%	25%	51%	49%	105%	73%	68%	102%	88%	73%
2011	2012	2013	2014	2015	2016	2017	2018	2019	2020	
136%	35%	49%	90%	83%	80%	100%	36%	110%	110%	

Source: [UCR Water Operations: Historic Data \(2000-2020\)](#)

¹⁷ Water Year: October 1 through September 30 of following year, so water year ending September 30, 1999

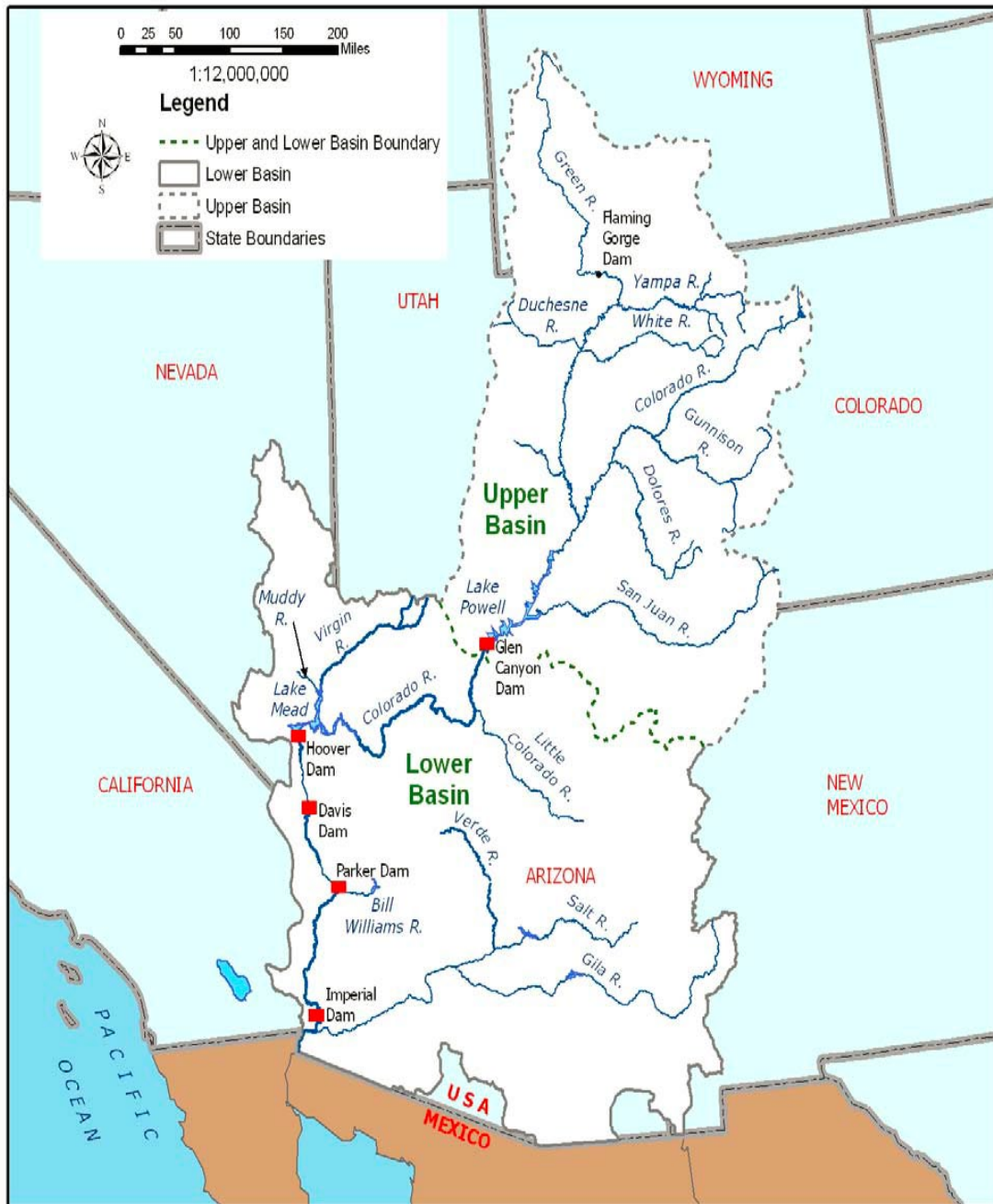


Figure 5. Major Colorado River Reservoir Storage Facilities and Basin Location Map

Source: [Final EIS – Colorado River Interim Guidelines for Lower Basin Shortages and Coordinated Operations for Lake Powell and Lake Mead, Volume 1 Chapter 1 Purpose and Need](#) , p I-10.

In the midst of the drought period, USBR developed 2007 Interim Guidelines with consensus from the seven basin states, which selected the Draft EIS Preferred Alternative as the basis for USBR’s final

determination. The basin states found the Preferred Alternative best met all aspects of the purpose and need for the federal action.¹⁸

The 2007 Interim Guidelines Preferred Alternative highlights the following:

1. The need for the Interim Guidelines to remain in place for an extended period of time.
2. The desirability of the Preferred Alternative based on the facilitated consensus recommendation from the basin states.
3. The likely durability of the mechanisms adopted in the Preferred Alternative in light of the extraordinary efforts that the basin states and water users have undertaken to develop implementing agreements that will facilitate the water management tools (shortage sharing, forbearance, and conservation efforts) identified in the Preferred Alternative
4. That the range of elements in the Preferred Alternative will enhance the Secretary's ability to manage the Colorado River reservoirs in a manner that recognizes the inherent tradeoffs between water delivery and water storage.

In June 2007, USBR announced that a preferred alternative for Colorado River Interim Guidelines for Lower Basin Shortages and Coordinated Operations of Lake Powell and Lake Mead (Final Preferred Alternative) had been determined. The Final Preferred Alternative, based on the basin states' consensus alternative and an alternative submitted by the environmental interests called "Conservation Before Shortage," is comprised of four key operational elements which are to guide operations of Lake Powell and Lake Mead through 2026 are:

1. Shortage strategy for Lake Mead and Lower Division states: The Preferred Alternative proposed discrete levels of shortage volumes associated with Lake Mead elevations to conserve reservoir storage and provide water users and managers in the Lower Basin with greater certainty to know when, and by how much, water deliveries will be reduced during low reservoir conditions.
2. Coordinated operations of Lake Powell and Lake Mead: The Preferred Alternative proposed a fully coordinated operation of the reservoirs to minimize shortages in the Lower Basin and to avoid risk of curtailments of water use in the Upper Basin.
3. Mechanism for storage and delivery of conserved water in Lake Mead: The Preferred Alternative proposed the Intentionally Created Surplus (ICS) mechanism to provide for the creation, accounting, and delivery of conserved system and non-system water thereby promoting water conservation in the Lower Basin. Credits for Colorado River or non-Colorado River water that has been conserved by users in the Lower Basin creating an ICS would be made available for release from Lake Mead at a later time. The total amount of credits would be 2.1 MAF, but this amount could be increased up to 4.2 MAF in future years.

¹⁸ USBR *Colorado River Interim Guidelines for Lower Basin Shortages and Coordinated Operations for Lake Powell and Lake Mead* <<http://www.usbr.gov/lc/region/programs/strategies.html>>

4. Modifying and extending elements of the Interim Surplus Guidelines (ISG). The ISG determines conditions under which surplus water is made available for use within the Lower Division states. These modifications eliminate the most liberal surplus conditions thereby leaving more water in storage to reduce the severity of future shortages.

With respect to the various interests, positions and views of the seven basin states, this provision adds an important element to the evolution of the legal framework for prudent management of the Colorado River. Furthermore, the coordinated operation element allows for adjustment of Lake Powell releases to respond to low reservoir storage conditions in either Lake Powell or Lake Mead.¹⁹ States found the Preferred Alternative best met all aspects of the purpose and need for the federal action.²⁰ The 2007 Interim Guidelines are in place from 2008 through December 31, 2025 (through preparation of the 2026 Annual Operating Plan).

Lower Colorado Region Water Shortage Operations

The drought in the Colorado River watershed has continued through 2020 despite an increase in observed runoff in August 2011 when unregulated inflow to Lake Powell was 279 percent of the average. Since 2000, Lake Mead has been below the “average” level of lake elevations (see [Figure 6](#)). Such conditions have caused the preparation of shortage plans for waters users in Arizona and Nevada, and in Mexico.

¹⁹ For a discussion of the 2007 Interim Guidelines, see: [Intermountain West Climate Summary](#) by The Western Water Assessment, issued Jan. 21, 2008, Vol. 5, Issue 1, January 2009 Climate Summary, Feature Article, pages 5-7, 22 Mar 2013.

²⁰ [USBR Colorado River Interim Guidelines for Lower Basin Shortages and Coordinated Operations for Lake Powell and Lake Mead](#).

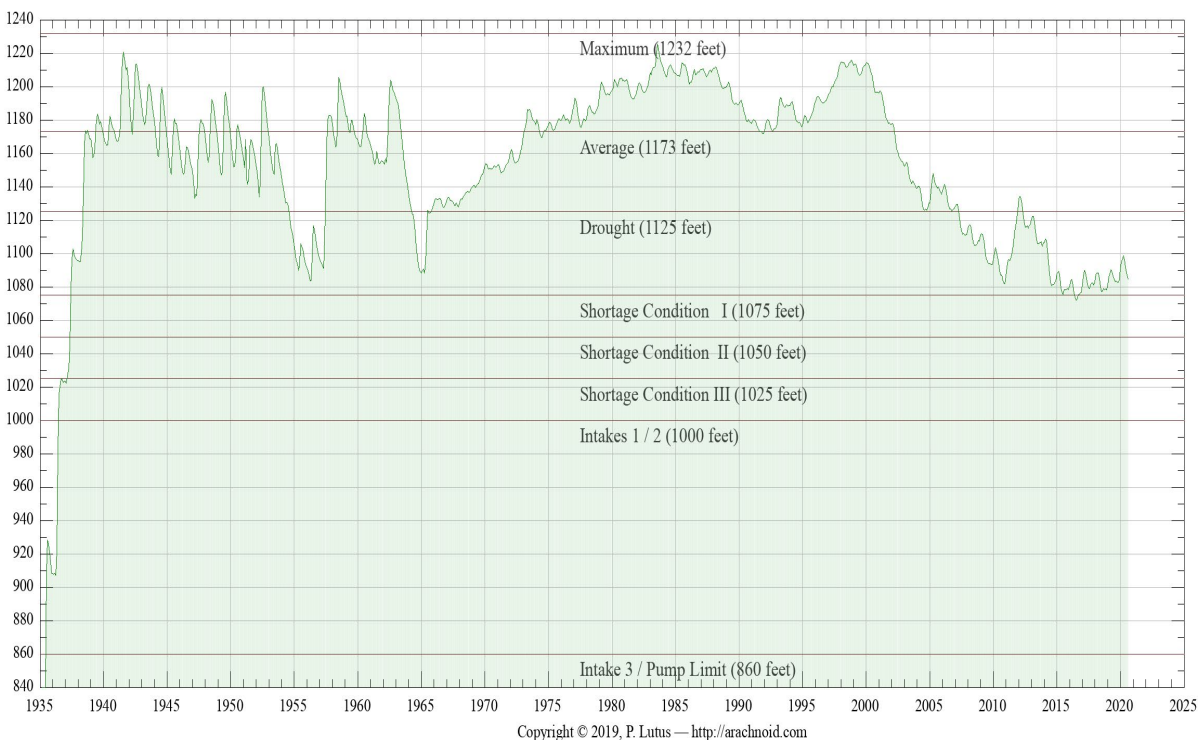


Figure 6. Lake Mead Water Elevation Levels 2020 visit <http://www.arachnoid.com/NaturalResources/index.html>

According to guidelines put in place in 2007, Arizona and Nevada begin to take shortages when the water elevation in Lake Mead falls below 1,075 feet. The volumes of shortages increase as water levels fall to 1,050 feet and again at 1,025 feet. In 2012, Mexico agreed to participate in a 5-year pilot agreement to share specific volumes of shortages at the same elevations. The 2007 interim shortage guidelines contain no reductions for California, which has senior water rights to the Central Arizona Project water supply, through 2025 when the guidelines expire. If Lake Mead's elevation drops to 1,025 feet, a re-consultation process would be triggered among the basin states to address next steps. Consultation would start out within each state, then move to the three lower basin states, followed by all seven states and the USBR. Mexico will then be brought into the process unless they choose to participate earlier.

IMPERIAL IRRIGATION DISTRICT WATER SUPPLY AND DEMAND

SB 610 requires an analysis of a normal, single dry, and multiple dry water years to show that adequate water is available for the proposed Project in various climate scenarios. Water availability for this Project in a normal year is no different from water availability during a single-dry and multiple-dry year scenarios. This is due to the small effect rainfall has on water availability in IID's arid environment along with IID's strong entitlements to the Colorado River water supply. Local rainfall does have some impact on how much water is consumed (i.e. if rain falls on agricultural lands, those lands will not demand as

much irrigation), but does not impact the definition of a normal year, a single-dry year or a multiple-dry year scenario.

Water Availability – Normal Year

IID is entitled to annual net consumptive use of 3.1 MAF of Colorado River, less its QSA/Transfer Agreement obligations. Imperial Dam, located north of Yuma, Arizona, serves as a diversion structure for water deliveries throughout southeastern California, Arizona and Mexico. Water is transported to the IID water service area through the AAC for use throughout the Imperial Valley. IID historic and forecast net consumptive use volumes at Imperial Dam from CRWDA Exhibit B are shown in Table 11. Volumes 2003-2020 are adjusted for USBR Decree Accounting historic records. Volumes for 2021-2077 are from CRWDA Exhibit B modified to reflect 2014 Letter Agreement changes to the 1988 IID/MWD Water Conservation Agreement.²¹

Table 11. IID Historic and Forecast Net Consumptive Use for Normal Year, Single-Dry Year and Multiple-Dry Year Water Supply, 2003-2037, et seq. (CRWDA Exhibit B)

IID Quantification and Transfers, Volumes in KAF at Imperial Dam ¹										
Col 1	2	3	4	5	6	7	8	9	10	11
Year	IID Priority 3(a)									IID Net [Available for] Consumptive Use (Col 2 - 10)
	IID 3(a) Quantified Amount	IID Reductions							IID Total Reduction (Σ Cols 3-9) ⁵	
		1988 MWD Transfer ²	SDCWA Transfer	AAC Lining	Salton Sea Mitigation SDCWA Transfer ³	Intra- Priority 3 CVWD Transfer	MWD Transfer w\ Salton Sea Restoration ⁴	Misc. PPRs		
2003	3,100	105.1	10.0	0.0	0.0	0.0	0.0	11.5	126.6	2978.2
2004	3,100	101.9	20.0	0.0	15.0	0.0	0.0	11.5	148.4	2743.9
2005	3,100	101.9	30.0	0.0	15.0	0.0	0.0	11.5	158.4	2756.8
2006	3,100	101.2	40.0	0.0	20.0	0.0	0.0	11.5	172.7	2909.7
2007	3,100	105.0	50.0	0.0	25.0	0.0	0.0	11.5	191.5	2872.8
2008	3,100	105.0	50.0	8.9	26.0	4.0	0.0	11.5	205.4	2825.1
2009	3,100	105.0	60.0	65.5	30.1	8.0	0.0	11.5	280.1	2566.7
2010	3,100	105.0	70.0	67.7	33.8	12.0	0.0	11.5	294.8	2540.5
2011	3,100	103.9	63.3	67.7	0.0	16.0	0.0	11.5	262.4	2915.8
2012	3,100	104.1	106.7	67.7	15.2	21.0	0.0	11.5	326.2	2,903.2
2013	3,100	105.0	100.0	67.7	71.4	26.0	0.0	11.5	381.6	2,554.9
2014	3,100	104.1	100.0	67.7	89.2	31.0	0.0	11.5	403.5	2,533.4
2015	3,100	107.82	100.0	67.7	153.3	36.0	0.0	11.5	476.3	2,480.9
2016	3,100	105.0	100.0	67.7	130.8	41.0	0.0	11.5	456.0	2,504.3
2017	3,100	105.0	100.0	67.7	105.3	45.0	0.0	9.9	434.5	2,548.2
2018	3,100	105	130	67.7	0.1	63	0.0	11.5	377.3	2,722.8
2019 ⁶	3,100	105	160	67.7	46.55	68	0.0	11.5	458.75	2,687.8

²¹ [2014 Imperial Irrigation District Letter Agreement](#) for Substitution and Conservation Modifications to the IID/MWD Water Conservation Agreement - December 17, 2014.

IID Quantification and Transfers, Volumes in KAF at Imperial Dam ¹										
Col 1	2	3	4	5	6	7	8	9	10	11
Year	IID Priority 3(a)								IID Total Reduction (Σ Cols 3-9) ⁵	IID Net [Available for] Consumptive Use (Col 2 - 10)
	IID 3(a) Quantified Amount	IID Reductions								
		1988 MWD Transfer ²	SDCWA Transfer	AAC Lining	Salton Sea Mitigation SDCWA Transfer ³	Intra-Priority 3 CVWD Transfer	MWD Transfer w\ Salton Sea Restoration ⁴	Misc. PPRs		
2020	3,100	105	192.5	67.7	0.0	73	0.0	9.8	448.0	2,652.0
2021	3,100	105	205	67.7	0	78	0.0	11.5	467.2	2,632.8
2022	3,100	105	203	67.7	0	83	0.0	11.5	470.2	2,629.8
2023	3,100	105	200	67.7	0	88	0.0	11.5	472.2	2,627.8
2024	3,100	105	200	67.7	0	93	0.0	11.5	477.2	2,622.8
2025	3,100	105	200	67.7	0	98	0.0	11.5	482.2	2,617.8
2026	3,100	105	200	67.7	0	103	0.0	11.5	487.2	2,612.8
2027	3,100	105	200	67.7	0	103	0.0	11.5	487.2	2,612.8
2028	3,100	105	200	67.7	0	103	0.0	11.5	487.2	2,612.8
2029-37	3,100	105	200	67.7	0	103	0.0	11.5	487.2	2,612.8
2038-47 ⁷	3,100	105	200	67.7	0	103	0.0	11.5	487.2	2,612.8
2048-77 ⁸	3,100	105	200	67.7	0	50	0.0	11.5	434.2	2,665.8

1. 2003 through 2020, volumes are adjusted for actual USBR Decree Accounting values; IID Total Reduction and Net Available for Consumptive Use may not equal Col 2 minus Col 10, if IID conservation/use was not included in Exhibit B.
2. 2014 Letter of Agreement provides that, effective January 2016 total amount of conserved water available is 105 KAFY
3. Salton Sea Mitigation volumes may vary based on conservation volumes and method of conservation.
4. This transfer is not likely given lack of progress on Salton Sea restoration as of 2018; shaded entries represents volumes that may vary..
5. Reductions include conservation for 1988 IID/MWD Transfer, IID/SDCWA Transfer, AAC Lining; SDCWA Transfer Mitigation, MWD Transfer w/Salton Sea Restoration (if any); Misc. PPRs. Amounts are independent of increases and reductions as allowed by the IOPP.
6. In order to resolve the outstanding 2010 Salton Sea mitigation water pre-delivery issue, IID left 46,546 AF of extraordinary conservation in Lake Mead. See IID's December 19, 2019 revised 2019 water order and Reclamation's March 10, 2020 approval letter.
7. Assumes SDCWA does not elect termination in year 35.
8. Assumes SDCWA and IID mutually consent to renewal term of 30 years.
9. Modified from 100 KAFY in CRWDA Exhibit B; stating in 2018 MWD will provide CVWD 50 KAFY of the 100 KAFY.

Source: [CRWDA: Federal QSA](#) Exhibit B, p 13; updated values from [2019 QSA Implementation Report](#)

Due to limits on annual consumptive use of Colorado River water under the QSA/Transfer Agreements, IID's water supply during a normal year is best represented by the CRWDA Exhibit B Net Available for Consumptive Use (Table 11 , Column 11). The annual volume is IID Priority 3(a) Quantified Amount of 3.1 million acre-feet (MAF) (Table 11 , Column 2) less the IID transfer program reductions for each year (Table 11, Columns 3-9). IID suggests Table 11, which assumes full use of IID's quantified water supply, be used in determining base normal year water availability.

CRWDA Exhibit B Net Available for Consumptive Use volumes less system operation demand represents the amount of water available for delivery by IID Water Department to its customers each year. In a normal year, perhaps 50,000 to 100,000 AF of effective rainfall would fall in the IID water service area. However, rainfall is not evenly distributed throughout the IID water service area and is not taken into account by IID in the submittal of its Estimate of Diversion (annual water order) to the USBR.

Expected Water Availability – Single Dry and Multiple Dry Years

When drought conditions exist within the IID water service area, as has been the case for the past decade or so, the water supply available to meet agricultural and non-agricultural water demands remains the same as normal year water supply because IID continues to rely solely on its entitlement for Colorado River water. Due to the priority of IID water rights and other agreements, drought conditions affecting Colorado River water supplies cause shortages for Arizona, Nevada and Mexico, before impacting California and IID. Accordingly, the Net Available for Consumptive Use volumes in Table 11, Column 11 represents the water supply at Imperial Dam available for diversion by IID in single-dry year and multiple-dry year scenarios.

Under CRWDA Inadvertent Overrun Payback Policy (IOPP), IID has some flexibility to manage its water use. When the water level in Lake Mead is above 1,125 feet, an overrun of its USBR approved annual water order is permissible, and IID has up to three years to pay water use above the annual water order. When Lake Mead’s water level is at or below 1,125 feet on January 1 in the calendar year after the overrun is reported in the USBR Lower Colorado Region Decree Accounting Report, the IOPP prohibits additional overruns and requires that outstanding overruns be paid back in the subsequent calendar year rather than in three years as allowed under normal conditions; that is, the payback is to be made in the calendar year following publication of the overrun in the USBR Decree Accounting Report. For historic IID annual rainfall, net consumptive use, transfers and IID underrun/overrun amounts, see Table 12. For purposes of this WSA, years with a shortage condition that impacts non-agricultural projects such as an IOPP payback obligation constitute “dry” years for IID.

In years of inadvertent overrun payback, conditions such as those in Sections 3.7 and 3.8 of the 2012 IWSP Water Agreement may go into effect, with the result that less water would be available for non-agricultural development contractors. Under such conditions, IID has requested that Vega SES 4, LLC management work with IID to ensure it can manage the reduction. IID has further indicated that, provided a water supply agreement is approved and executed by IID under the provisions of the IWSP, IID will have sufficient water to support the water of this Project.

Table 12. IID Annual Rainfall (In), Net Consumptive Use and Underrun/Overrun Amounts (AF), 1988-2020

Year	IID Total Annual Rainfall	IID Water Users	IID/MWD Transfer	IID/ SDCWA Transfer	SDCWA Transfer Salton Sea Mitigation	IID Underrun /<Overrun>	IID/CVWD Transfer	AAC Lining
1988		2,947,581						
1989		3,009,451						
1990	91,104	3,054,188	6,110					
1991	192,671	2,898,963	26,700					
1992	375,955	2,575,659	33,929					
1993	288,081	2,772,148	54,830					
1994	137,226	3,048,076	72,870					
1995	159,189	3,070,582	74,570					

Year	IID Total Annual Rainfall	IID Water Users	IID/MWD Transfer	IID/ SDCWA Transfer	SDCWA Transfer Salton Sea Mitigation	IID Underrun /<Overrun>	IID/CVWD Transfer	AAC Lining
1996	78,507	3,159,609	90,880					
1997	64,407	3,158,486	97,740					
1998	100,092	3,101,548	107,160					
1999	67,854	3,088,980	108,500					
2000	29,642	3,112,770	109,460					
2001	12,850	3,089,911	106,880					
2002	12,850	3,152,984	104,940					
2003	116,232	2,978,223	105,130	10,000	0	<6,555>		
2004	199,358	2,743,909	101,900	20,000	15,000	-166,408		
2005	202,983	2,756,846	101,940	30,000	15,000	-159,881		
2006	19,893	2,909,680	101,160	40,000	20,000	<12,414>		
2007	64,580	2,872,754	105,000	50,000	25,021	<6,358>		
2008	63,124	2,825,116	105,000	50,000	26,085	-47,999	4,000	8,898
2009	30,0354	2,566,713	105,000	60,000	30,158	-237,767	8,000	65,577
2010	189,566	2,545,593	105,000	70,000	33,736	-207,925	12,000	67,700
2011	109,703	2,915,784	103,940	63,278	0	<82,662>	16,000	67,700
2012	133,526	2,903,216	104,140	106,722	15,182	<134,076>	21,000	67,700
2013	134,497	2,554,845	105,000	100,000	71,398	-64,981	26,000	67,700
2014	53,517	2,533,414	104,100	100,000	89,168	-797	31,000	67,700
2015	97,039	2,480,933	107,820	100,000	153,327	-90,025	36,000	67,700
2016	90,586	2,504,258	105,000	100,000	130,796	-62,497	41,000	67,700
2017	105,919	2,548,171	105,000	100,000	105,311	-30,591	45,000	67,700
2018	63,318	2,625,422	105,000	130,000	0	0	63,000	67,700
2019	146,384	2,558,136	105,000	160,000	46,555	-34,215	68,000	67,700
2020	129,693	2,493,661	105,000	192,500	0	-95,715	73,000	67,700

Notes: Volumes in acre-feet and except Total Annual Rainfall are USBR Decree Accounting Report record at Imperial Dam.

IID Total Annual Rainfall from IID Provisional Water Balance, first available calculations are for 1990

Not all IID QSA programs are shown on this table.

Source: USBR Decree Accounting reports, except IID Total Rainfall and IID Overrun/Underrun is a separate calculation

Source: 2019 IID QSA Implementation Report and 2020 IID SWRCB Report, page 31 of 335; IID Total Rainfall and IID Overrun/Underrun is a separate calculation

Equitable Distribution Plan (EDP)

A 2006 study by Hanemann and Brookes suggested that overrun conditions were likely to occur 40-50% of the years during the decade following the report. On November 28, 2006, the IID Board of Directors adopted Resolution No 22-2006 approving development and implementation of an Equitable Distribution Plan to deal with times when customers’ demand would exceed IID’s Colorado River supply. The EDP, adopted in 2007 allowed the IID Board to institute an apportionment program. As part

of this resolution, the IID Board directed the General Manager to prepare the rules and regulations necessary or appropriate to implement the plan within the district. The 2009 Regulations for EDP were created to enable IID to implement a water management tool (apportionment) to address years in which water demand is expected to exceed supply. So far, for the 17 years from 2003 through 2020, demand has exceeded supply by some amount for a total of five years (see Table 12). IID has not experienced any overruns since 2012.

The IID 2013 Revised EDP, adopted by the Board on October 28, 2013, further allowed IID to pay back its outstanding overruns using an EDP Apportionment, and it was expected that an annual EDP Apportionment would be established for each of the next several years, if not for the duration of the QSA/Transfer Agreements. For purposes of this WSA, years with a shortage condition that impacts non-agricultural projects such as an IOPP payback obligation constitute “dry” years for IID. For single-dry year and multiple-dry water year assessments, IID’s EDP shall govern. IOPP payback, EDP Apportionment, and the IWSP are further discussed under single-dry and multiple-dry year projections. However, the implementation of the EDP apportionment was legally challenged, and on February 6, 2018, the IID board approved a resolution repealing the EDP until the issue is resolved. As of the date of this WSA, a resolution had been reached, but a modified EDP has yet to be re-instated.

Water Management under Inadvertent Overrun Payback Policy (IOPP)

On January 1, 2013, the water level in Lake Mead was 1120.5 feet and for the first time since the IOPP came into effect, Lower Colorado River Basin water users faced a shortage condition (Figure 7). For IID, this meant that outstanding overruns must be paid back to the river in calendar years 2013 and 2014 as described below and shown in Table 13.

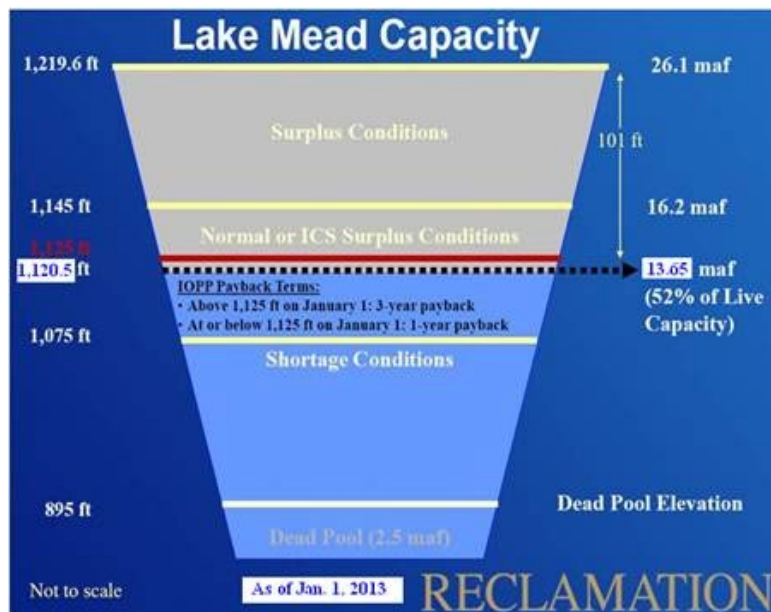


Figure 7. Lake Mead IOPP Schematic

IID’s maximum allowable cumulative overrun account is 62,000 AF.²² Thus, for IID’s 2011 overrun of 82,662 AF (which was published in 2012), 62,000 AF were to be paid back at the river in calendar year 2013, with the remaining 20,662 AF to be paid back in 2014; however, due to an early payback of 6,290 AF in 2012, IID had 55,710 AF to pay back in 2013 and 20,662 AF of the 2011 overrun to pay back in 2014. In addition, because of the low level of Lake Mead on Jan 1, 2013, IID’s entire 2012 overrun of 134,076 AF must be paid back in 2014, for a total of 154,738 AF in 2014. Furthermore, under the terms of the IOPP, no overruns are allowed in a year when payback is required. IID has not experienced any overrun pay back since 2014.

Table 13. IID Inadvertent Overrun Payback to the Colorado River under the IOPP, 2012-2020

Calendar Year of Payback	2011 Overrun Payback (AF)	2012 Overrun Payback (AF)	Payback Total for Calendar Year (AF)
2013	55,710	-	55,710
2014	20,662	134,076	154,738
Total Payback	76,372	134,076	210,448

Notes: All values are consumptive use volumes at Imperial Dam (AF).
 2013 Payback Total was 62 KAF, but in 2012 IID had 6,290 AF of early payback, reducing volume to 55,710 AF

The 2013 IOPP payback obligation and prohibition on overruns in payback years, led the IID Board to implement an apportionment program pursuant to the 2009 Regulations for EDP, which were subsequently revised and modified. The Revised 2013 EDP was a version approved and adopted by the IID Board on October 28, 2013 (see Attachment B). The Revised 2013 EDP also establishes an agriculture water clearinghouse to facilitate the movement of apportioned water between agricultural water users and between farm units. This is to allow growers and IID to balance water demands for different types of crops and soils with the apportionment s that are made. IID’s Water Conservation Committee agreed on a July 1, 2013 start date for the agricultural water clearinghouse

Generally, the EDP Apportionment is not expected to impact industrial use. However, given the possibility of continuing drought on the Colorado River and other stressors, provisions such as the 2012 IWSP Water Agreement sections 3.7 and 3.8 as well for dry and multiple dry year water assessment may come into effect. However, IID has agreed to work with Project proponents to ensure to the extent possible that the IWSP Water Agreement terms will not negatively impact Project operation.

Project Water Availability for a 20-Year Period to Meet Projected Demands

The proposed Project will obtain drinking water from a certified State of California provider. Approximately 275 AF of untreated canal water will be used during the 18-month construction period for dust control and soil conditioning. During operations, up to 10 AFY of untreated canal water will be used for washing of the solar PV modules, as needed. Bottled water will be provided for potable needs during construction. Water for employee sanitation will be provided by temporary, portable facilities (toilets and hand wash stations). There will be no potable water connection to the facility.

²² For IID Quantified Amount: 3.1 MAFY *10 percent = 310,000 AF allowable cumulative overrun account amount; minimum repayment in a calendar year is the less of 310,000 * 20 percent = 62,000 or the amount in the account, if less than 62,000 AF.

Untreated Colorado River water will be supplied to the project via the adjacent All American Canal under an IWSP Water Supply Agreement with IID. The Project site is currently open land and does not receive water from IID. Thus, the proposed Project water demand would be a new use within the District service area.

As noted previously, under the terms of California legislation adopted to facilitate the QSA/Transfer Agreements and enacted in [CWC Section 1013](#), the IID board adopted the [TLCFP](#) to address how to deal with any such temporary reduction of water use by projects like such as solar projects that are developed under a CUP.

While conserved water generated from the TLCFP is limited by law for use for water transfer or environmental purposes, by satisfying multiple district objectives the TLCFP serves to reduce the need for efficiency conservation and other water use reduction practices on the part of IID and its water users providing the district with wide benefits. One of the considerations in developing the TLCFP was to provide agricultural land owners with long-term assurances from IID that, at Project termination, irrigation service would be available for them to resume farming operations.

IWSP Water

At the present time, IID is providing water for use by solar energy generation projects under Water Rate [Schedule 7 General Industrial Use](#). If IID determines that the proposed Project should obtain water under IID's Interim Water Supply Policy (IWSP) for non-agricultural projects rather than [Schedule 7 General Industrial Use](#), the Applicant will do so. IID will determine whether the Project should obtain water under IID's Interim Water Supply Policy (IWSP) for non-agricultural projects in addition to Schedule 7 General Industrial Water.

The IWSP, provided herein as Attachment A, designates up to 25,000 AFY of water for potential Non-Agricultural Projects within IID's water service area. As of January 2021, IID has 23,800 AF available under the IWSP for new projects such as the proposed project. The IWSP establishes a schedule for Processing Fees, Reservation Fees, and Connection Fees that change each year for all non-agricultural projects, and annual Water Supply Development fees for some non-agricultural projects. The proposed Project's water use will be subject to the annual Water Supply Development fee if IID determines that water for the Project is to be supplied under the IWSP.

The likelihood that IID will not receive its annual 3.1 MAF apportionment less QSA/Transfer Agreement obligations of Colorado River water is low due to the high priority of the IID entitlement relative to other Colorado River contractors, see IID's Water Rights section on [page 22](#). If such reductions were to come into effect within the 20-year Project life, the Applicants are to work with IID to ensure any reduction can be managed.

As such, lower Colorado River water shortage does not present a material risk to the available water supply that would prevent the County from making the findings necessary to approve this WSA. IID, like any water provider, has jurisdiction to manage the water supply within its service area and impose

conservation measures during a period of temporary water shortage. Furthermore, without the proposed Project, IID’s task of managing water supply under the QSA/Transfer Agreements would be more difficult, because agricultural use on the proposed Project site would be significantly higher than the proposed demand for the proposed Project as explained in the Expected Water Demands for the Proposed Project on the section that follows.

Water for construction (primarily for dust control) would be obtained from IID canals or laterals in conformance with IID rules and regulations for MCI temporary water use.²³ Water would be picked up from a nearby canal or lateral and delivered to the construction location by a water truck capable of carrying approximately 4,000 gallons per load. To obtain water delivery service, the Project proponent will complete an [IID-410 Certificate of Ownership and Authorization](#) (Water Card), which allows the Water Department to provide the district with information needed to manage the district apportioned supply. Water cards are used for Agriculture, Municipal, Industrial and Service Pipe accounts. If water is to be provided under IWSP in addition to Schedule 7. General Industrial Use, the Applicant will seek to enter into a IWSP Water Supply Agreement.

Expected Water Demands for the Proposed Project

Water for the Project will be needed on-site for dust control and soil condition during the 18-month construction period and for PV module washing during the 30-year operational phase (see Table 14). Untreated Colorado River water will be supplied to the project via the adjacent All American Canal under an IWSP Water Supply Agreement with IID. The Project site is currently open land and does not receive water from IID. Thus, the proposed Project water demand would be a new use within the District service area.

Project raw water uses are summarized in in Table 14.

Table 14. Project Water Uses (AFY)

Use	Acre-Feet per Year
Raw Water for construction (275 AF total over 18 months = 183.3 AFY)	183.3
Raw Water for PV module washing	10
TOTAL RAW WATER USAGE (long term)	10

IID currently does not deliver untreated Colorado River water to the proposed Project site for agricultural uses.

The proposed Project has an estimated total water demand of 460 AF or 23 AFY amortized over a 20-year term (to be pumped to water trucks directly from the All American Canal – there would be no diversion through any delivery gates for Project). Thus, the proposed Project demand is an increase of

²³ Complete the Application for Temporary Water Use and submit to Division office. Complete encroachment permit through Real Estate – non-refundable application fee of \$250, se. IID website: [Real Estate / Encroachments, Permissions, and Other Permitting](#). Fee for temporary service water: Schedule No. 7 General Industrial Use / Temporary Service Minimum charge for up to 5 AF, pay full flat fee for 5 AF at General Industrial Use rate (\$425); use more than 5 AF, pay fee for actual use at General Industrial Rate (\$85/AF).

23 AFY from the historical 10-year average. There has been no prior delivery for agricultural uses at the proposed Project site. The proposed Project’s estimated water demand of 23 AFY amortized over 20 years represents only 0.1 percent (0.1%) of the 23,800 AYF balance of supply available for contracting under the IWSP.

IID’s Ability to Meet Demands With Water Supply

Non-agricultural water demands for the IID water service area are projected for 2025-2055 in Table 5, and IID agricultural demands including system operation are projected for 2025-2055 in Table 6, all volumes within the IID water service area. IID water supplies available for consumptive use after accounting for mandatory transfers are projected to 2077 in Table 11 (Column 11), volumes at Imperial Dam.

To assess IID’s ability to meet future water demands, IID historic and forecasted demands are compared with CRWDA Exhibit B net availability, volumes at Imperial Dam Table 11 (Column 11). The analysis requires accounting for system operation consumptive use within the IID water service area, from AAC at Mesa Lateral 5 to Imperial Dam, and for water pumped for use by the USBR Lower Colorado Water Supply Project (LCRWSP), an IID consumptive use component in the USBR Decree Accounting Report. IID system operation consumptive use for 2015 is provided in Table 15 to show the components included in the calculation and their 2015 volumes.

Table 15. IID System Operations Consumptive Use within IID Water Service Area and from AAC at Mesa Lateral 5 to Imperial Dam, (KAF), 2020

	Consumptive Use (KAF)
IID Delivery System Evaporation	24.4
IID Canal Seepage	90.8
IID Main Canal Spill	10.1
IID Lateral Canal Spill	121.5
IID Seepage Interception	-39.0
IID Unaccounted Canal Water	-40.0
Total IID System Operational Use, within water service area	167.8
“Losses” from AAC @ Mesa Lat 5 to Imperial Dam	9.2
LCWSP pumpage	-10
Total System Operational Use in 2020	167.0

Source: 2020 IID Water Balance Rerun 01/25/2021

IID’s ability to meet customer water demands through 2055 as shown in Table 16 is based on the following:

- Non-agricultural use from Table 5.
- Agricultural and Salton Sea mitigation uses from Table 6.
- CRWDA Exhibit B net available for IID consumptive use from Table 11.
- System operation consumptive use from Table 15.

Table 16. IID Historic and Forecasted Consumptive Use vs CRWDA Exhibit B IID Net Available Consumptive Use, volumes at Imperial Dam (KAFY), 2015-2055 Next Update in 2026 thru 2065

	2015	2020	2025	2030	2035	2040	2045	2050	2055
Non-Ag Delivery	110.1	115.2	133.1	142.9	151.4	163.2	175.4	188.4	199.3
Ag Delivery	2,156.8	2,165.4	2,259.5	2,209.5	2,209.5	2,209.5	2,209.5	2,209.5	2,209.5
QSA SS Mitigation Delivery	153.3	0.0	0.0	0.0	0.0	0.0	0.0	0.0	0.0
System Op CU in IID & to Imperial Dam	220.2	167.0	230.5	225.4	225.4	225.4	225.4	225.4	225.4
IID CU at Imperial Dam	2,480.9	2,493.7	2,623.1	2,577.8	2,586.3	2,598.1	2,610.3	2,623.3	2,634.2
Exhibit B IID Net Available for CU at Imperial Dam	2,480.9	2,652.0	2,617.8	2,612.8	2,612.8	2,612.8	2,612.8	2,665.8	2,665.8
IID Underrun/Overrun at Imperial Dam	90.0	-98.1	-5.30	35.00	26.50	14.70	2.50	42.50	31.60

Notes: 2015 Provisional Water Balance rerun 06/28/2019
 Non-Ag Delivery CI 15.0%, Ag Delivery CI 3.0%, QSA SS mitigation CI 15%
 QSA Salton Sea Mitigation Delivery terminates on 12/31/2017
 Underrun /Overrun = IID CU at Imperial Dam minus CRWDA Exhibit B Net Available

Notes: Ag Delivery for 2020-2055 does not take into account land conversion for solar use nor reduction in agricultural land area due to urban expansion.

As shown above, IID forecasted demand has the potential to exceed CRWDA Exhibit B Net Consumptive Use volumes during several time intervals through the lifespan projection for the Project. However, due to temporary land conversion for solar use and urban land expansion that will reduce agricultural acres in the future, a water savings of approximately 217,000 AFY will be generated into the future and for the lifetime of the Project.

In addition, USBR 2020 Decree Accounting Report states that IID Consumptive Use is 2,493.7 KAF (excludes 1,579 AF of ICS storage in Lake Mead and 49,444 AF of conserved water left on the Colorado River system) with an underrun of -98.1 KAF, as reported by IID in 2020 Annual SWRCB Report per WRO 2002-2013; that is, IID uses less than the amount in its approved Water Order (2,615,300 AF).

Table 17. 2020 Approved Water Order, Actual CU (Decree Accounting Report) and IID Underrun, KAF at Imperial Dam

IID Approved Water Order	2,625.3 less 10 supplied by LCWSP and less 26 of additional conserved water
IID Consumptive Use	2,493.7
IID Underrun /Overrun	-98.1

Sources:
 2020 IID Revised Water Order, approved on March 10, 2020, 2019 Decree Accounting Report, and 2020 Annual Report of IID Pursuant to SWRCB Revised Order WRO 2002-2013

As reported in the 2019 QSA Implementation Report and 2020 SWRCB IID Report and presented in Table 17, from 2013 to 2020 IID consumptive use (CU) resulted in underruns; i.e., annual CU was less than the district’s QSA Entitlement of 3.1 MAFY minus QSA/Transfer Agreements obligations. This would indicate that even though Table 16 shows IID Overrun/Underrun at Imperial Dam exceeding CRWDA Exhibit B Net Available for CU, for the 30-year life of the proposed Project, IID consumptive use may be less than forecasted.

Meanwhile, forecasted Ag Delivery reductions presented in **Table 6** are premised on implementation of on-farm practices that will result in efficiency conservation. These reductions do not take into account land conversion for solar projects nor reduction in agricultural land area due to urban expansion; that is to say, the forecasted Ag Delivery is for acreage in 2003 with reduction for projected on-farm conservation efficiency. Thus, Ag Delivery demand may well be less than forecasted in **Table 6**. In any case, the proposed Project will use less water than the historical agricultural demand of proposed Project site, so the proposed Project will ease rather than exacerbate overall IID water demands.

In the event that IID has issued water supply agreements that exhaust the 25 KAFY IWSP set aside, and it becomes apparent that IID delivery demands due to non-agriculture use are going to cause the district to exceed its quantified 3.1 MAFY entitlement less QSA/Transfer Agreements obligations, IID has identified options to meet these new non-agricultural demands. These options include (1) tracking water yield from temporary land conversion from agricultural to non-agricultural land uses (renewable solar energy); and (2) only if necessary, developing projects to expand the size of the district's water supply portfolio.

These factors will be discussed in the next two sections, Tracking Water Savings from Growth of Non-Agricultural Land Uses and Expanding Water Supply Portfolio.

Tracking Water savings from Growth of Non-Agricultural Land Uses

The Imperial County Board of Supervisors has targeted up to 25,000 acres of agricultural lands, about 5 percent (5%) of the farmable acreage served by IID, for temporary conversion to solar farms; because the board found that this level of reduction would not adversely affect agricultural production. As reported for IID's 2020 Temporary Land Conversion Following Program, existing solar developments at the end of 2020 have converted 12,404 acres of farmland. These projects had a yield at-river of 65,964 AF of water in 2020. The balance of the 25,000-acre agriculture-to-solar policy is 12,596 acres. On average, each agricultural acre converted reduces agricultural demand by 5.1 AFY, which results in a total at-river yield (reduction in consumptive use) of 127,500 AFY.

However, due to the nature of the conditional use permits under which solar farms are developed, IID cannot rely on this supply being permanently available. In fact, should a solar project decommission early, that land may go immediately back to agricultural use (it remains zoned an agricultural land). Nevertheless, during their operation, the solar farms do ameliorate pressure on IID to implement projects to meet demand from new non-agricultural projects.

Unlike the impact of solar projects, other non-agricultural uses are projected to grow, as reflected in the nearly 55 percent (55%) increase in non-agricultural water demand from 107.4 KAF in 2015 to 201.4 KAF in 2055 reflected herein in Table 5 This increase in demand of 94 KAFY will more than likely be met by solar development; however, as the land remains zoned as agricultural land, that source is not reliable to be permanently available to IID.

The amount of land developed for residential, commercial, and industrial purposes is projected to grow by 55,733 acres from 2015 to 2050²⁴ within the sphere of influence of the incorporated cities and specific plan areas in Imperial County. A conservative estimate is that such development will displace at least another 24,500 acres of farmland based on the Imperial Local Agency Formation Commission (LAFCO) sphere of influence maps and existing zoning and land use in Imperial County. At 5.13 AFY yield at-river, there would be a 125,000 AFY reduction IID net consumptive use.

The total foreseeable solar project temporary yield at-river (91,800 AFY) and municipal development permanent yield at-river (125,000 AFY) is to reduce forecasted IID net consumptive use at-river 216,800 AFY, which is more than enough to meet the forecast Demand minus Exhibit B Net Available volumes shown in Table 11. This Yield at-river is sufficient to meet the forecasted excess of non-agricultural use over Net Available supply within the IID service area for the next 20 years, as is required for SB 610 analysis.

Farmland retirement associated with municipal development would reduce IID agricultural delivery requirements beyond the efficiency conservation projections shown in **Table 6** and Table 16. Therefore, in the event that [Schedule 7 General Industrial Use](#) water is unavailable, the Applicants will rely on IID IWSP water to supply the Project, as discussed above in the Projected Water Availability section.

Expanding Water Supply Portfolio

While forecasted long-term annual yield-at-river from the reduction in agricultural acreage due to municipal development in the IID service area is sufficient to meet the forecasted excess of non-agricultural use over CRWDA Net Available supply (Table 11) without expanding IID's Water Supply Portfolio, IID has also evaluated the feasibility of a number of capital projects to increase its water supply portfolio.

As reported in [2012 Imperial IRWMP Chapter 12](#), IID contracted with GEI Consultants, Inc. to identify a range of capital project alternatives that the district could implement. Qualitative and quantitative screening criteria and assumptions were developed in consultation with IID staff. Locations within the IID water service area with physical, geographical, and environmental characteristics most suited to implementing short- and long-term alternatives were identified. Technical project evaluation criteria included volumes of water that could be delivered and/or stored by each project, regulatory and permitting complexity, preliminary engineering components, land use requirements, and costs.

After preliminary evaluation, a total of 27 projects were configured:

- 17 groundwater or drain water desalination
- 2 groundwater blending
- 6 recycled water
- 1 groundwater banking

²⁴ IRWMP, Chapter 5, Table 5-14.

- 1 IID system conservation (concrete lining)

Projects were assessed at a reconnaissance level to allow for comparison of project costs. IID staff and the board identified key factors to categorize project alternatives and establish priorities. Lower priority projects were less feasible due to technical, political, or financial constraints. Preferential criteria were features that increased the relative benefits of a project and grant it a higher priority. Four criteria were used to prioritize the IID capital projects:

1. **Financial Feasibility.** Projects whose unit cost was more than \$600/AF were eliminated from further consideration.
2. **Annual Yield.** Project alternatives generating 5,000 AF or less of total annual yield were determined not to be cost-effective and lacking necessary economies of scale.
3. **Groundwater Banking.** Groundwater banking to capture and store underruns is recognized as a beneficial use of Colorado River water. Project alternatives without groundwater banking were given a lower priority.
4. **Partnering.** Project alternatives in which IID was dependent on others (private and/or public agencies) for implementation were considered to have a lower priority in the IID review; this criterion was reserved for the IRWMP process, where partnering is a desirable attribute.

Based on these criteria, the top ten included six desalination, two groundwater blending, one system conservation, and one groundwater storage capital projects. These capital projects are listed in Table 18 which follows.

Table 18. IID Capital Project Alternatives and Cost (May 2009 price levels \$)

Name	Description	Capital Cost	O&M Cost	Equivalent Annual Cost	Unit Cost (\$/AF)	In-Valley Yield (AF)
GW 18	Groundwater Blending E. Mesa Well Field Pumping to AAC	\$39,501,517	\$198,000	\$2,482,000	\$99	25,000
GW 19	Groundwater Blending: E. Mesa Well Field Pumping to AAC w/Percolation Ponds	\$48,605,551	\$243,000	\$3,054,000	\$122	25,000
WB 1	Coachella Valley Groundwater Storage	\$92,200,000	\$7,544,000	\$5,736,746	\$266	50,000
DES 8	E. Brawley Desalination with Well Field and Groundwater Recharge	\$100,991,177	\$6,166,000	\$12,006,000	\$480	25,000
AWC 1	IID System Conservation Projects	\$56,225,000	N/A	\$4,068,000	\$504	8,000
DES 12	East Mesa Desalination with Well Field and Groundwater Recharge	\$112,318,224	\$6,336,000	\$12,831,000	\$513	25,000
DES 4	Keystone Desalination with IID Drain water/ Alamo River	\$147,437,743	\$15,323,901	\$23,849,901	\$477	50,000
DES 14	So. Salton Sea Desalination with Alamo River Water and Industrial Distribution	\$158,619,378	\$15,491,901	\$24,664,901	\$493	50,000
DES 15	So. Salton Sea Desalination with Alamo River Water and MCI Distribution	\$182,975,327	\$15,857,901	\$26,438,901	\$529	50,000

Name	Description	Capital Cost	O&M Cost	Equivalent Annual Cost	Unit Cost (\$/AF)	In-Valley Yield (AF)
DES 2	Keystone Desalination with Well Field and Groundwater Recharge	\$282,399,468	\$13,158,000	\$29,489,000	\$590	50,000

Source: Imperial IRWMP, Chapter 12; see also Imperial IRWMP Appendix N, IID Capital Projects

IID Near Term Water Supply Projections

As mentioned above, IID’s quantified Priority 3(a) water right under the QSA/Transfer Agreements secures 3.1 MAF per year, less transfer obligations of water for IID’s use from the Colorado River, without relying on rainfall in the IID service area. Even with this strong entitlement to water, IID actively promotes on-farm efficiency conservation and is implementing system efficiency conservation measures including seepage recovery from IID canals and the All-American Canal (ACC) and measures to reduce operational discharge. As the IID website [Water Department](#) states:

Through the implementation of extraordinary conservation projects, the development of innovative efficiency measures and the utilization of progressive management tools, the IID Water Department is working to ensure both the long-term viability of agriculture and the continued protection of water resources within its service area.

Overall, agricultural water demand in the Imperial Valley will decrease due to IID system and grower on-farm efficiency conservation measures that are designed to maintain agricultural productivity at pre-QSA levels while producing sufficient yield-at-river to meet IID’s QSA/Transfer Agreements obligations. These efficiencies combined with the conversion of some agricultural land uses to non-agricultural land uses (both solar and municipal), ensure that IID can continue to meet the water delivery demand of its existing and future agricultural and non-agricultural water users, including this Project for the next 20 years and for the life of the proposed Project.

IMPERIAL IRRIGATION DISTRICT FINDINGS

IID serves as the regional wholesale water supplier, importing raw Colorado River water and delivering it, untreated, to agricultural, municipal, industrial, environmental and recreational water users within its Imperial Unit water service area. Imperial County Planning and Development Services serves as the responsible agency with land use authority over the proposed project. Water Assessment findings are summarized as follows:

1. IID's annual entitlement to consumptive use of Colorado River water is capped at 3.1 MAF less water transfer obligations, pursuant to the QSA and Related Agreements. Under the terms of the CRWDA, IID is implementing efficiency conservation measure to reduce net consumptive use of Colorado River water needed to meet its QSA/Transfer Agreements obligations while retaining historical levels of agricultural productivity.
2. In 2020 IID consumptively used 2,493,661 AF of Colorado River water (volume at Imperial Dam); 2,278,598 AF were delivered to customers (including recreational and environmental water deliveries) of which 2,165,386 AF or 95 percent went to agricultural users as per IID's Water Balance run on 1/25/2021.
3. Reduction of IID's net consumptive use of Colorado River water under the terms of the Colorado River Water Delivery Agreement is to be the result of efficiency conservation measures. Agricultural consumptive use in the Imperial Valley will not decline. However, IID operational spill and tailwater will decline, impacting the Salton Sea.
4. Due to the dependability of IID's water rights, Colorado River flows, and Colorado River storage facilities for Colorado River water, it is unlikely that the water supply of IID would be disrupted, even in dry years or under shortage conditions because Mexico, Arizona and Nevada have lower priority and are responsible for reducing their water use during a declared Colorado River water shortage before impacting California.
5. Historically, IID has never been denied the right to use the annual volume of water it has available for its consumptive uses under its entitlement. Nevertheless, IID is participating in discussions for possible actions in response to extreme drought on the Colorado River.
6. The proposed Project has an estimated total water demand of 460 AF or 23 AFY amortized over a 20-year term. Water would typically be pumped from the All-American Canal by water trucks and not delivered through an existing gate. While the initial 18-month construction demand would be 275 AF, the on-going demand over the life of the Project would be 10 AFY. Thus, the proposed Project demand is an increase of 23 AFY from the historical 10-year average.
7. The Project's water use will be covered under the [Schedule 7 General Industrial Use](#). In the event that IID determines that the proposed Project is to utilize IWSP for Non-Agricultural Projects water, the Applicant will enter into an IWSP Water Supply Agreement with IID. In which case, the proposed Project would use 0.1 percent (0.1%) of the 23,800 AYF of IWSP water.

8. Based on the Environmental Impact Report (EIR) prepared for this proposed Project pursuant to the CEQA, California Public Resources Code sections 21000, *et seq.* (SCH No. 2021050018), the Lead Agency hereby finds that the IID projected water supply will be sufficient to satisfy the demands of this proposed Project in addition to existing and planned future uses, including agricultural and non-agricultural uses for a 20-year Water Supply Assessment period and for the 30 -year proposed Project life.
-

ASSESSMENT CONCLUSION

This Water Supply Assessment has determined that IID water supply is adequate for the Vega SES 4, LLC VEGA SES 4 Solar Energy Storage project (proposed Project). The Imperial Irrigation District's IWSP for Non-Agricultural Projects dedicates 25,000 AF of IID's annual water supply to serve new projects. As of January 2021, 23,800 AF per year remain available for new projects ensuring reasonably sufficient supplies for new non-agricultural water users. The project water demand of approximately 23 AFY amortized over 20 years represents 0.1 % of the unallocated supply set aside in the IWSP for non-agricultural project, and approximately 0.01 percent (0.01 %) of forecasted future non-agricultural water demands planned in the Imperial IRWMP through 2055. There has been no prior agricultural water use at the Project site.

For all the reasons described herein, the amount of water available and the stability of the IID water supply along with on-farm and system efficiency conservation and other measures being undertaken by IID and its customers ensure that Vega SES 4, LLC's water needs will be met for the next 20 years as assessed for compliance under SB-610.

RESOURCES AND REFERENCES

1. California Department of Water Resources. (2003). [Guidebook for Implementation of Senate Bill 610 and Senate Bill 221 of 2001](#) to assist water suppliers, cities, and counties in integrating water and land use planning.
2. Imperial County Planning and Development Services. (2008). Imperial County General Plan 2008 Update. El Centro, CA.
3. Imperial Irrigation District. Website: [Equitable Distribution](#).
4. Imperial Irrigation District Website: [Water Conservation Plan](#). (2008). Imperial Irrigation District 2007 Water Conservation Plan. Imperial, CA.
5. Imperial Irrigation District. (2004). IID [Interactive GIS Water Service Area Map](#). Imperial, CA.
6. Imperial Irrigation District. (2009). [Interim Water Supply Policy for Non-Agricultural Projects](#). Imperial, CA
7. Imperial Irrigation District. (2012). [Temporary Land Conversion Following Policy \(TLFCP\) for Water Conservation Yield](#) Water conservation yield attributable to land removed from agricultural production and temporarily fallowed. Updated March 27, 2018.
8. Imperial Irrigation District Water Department. (2013). [Colorado River Water Accounting and Conservation Commitments Update](#). Tina Anderholt Shields, PE. Colorado River Resources Manager Imperial, CA.
9. Imperial Irrigation District. (2017). [2016 QSA Water Conservation & Transfer Agreement Annual Implementation Report](#), Imperial, CA
- 10.
11. Imperial Irrigation District. (2017). Consultation with Anisa J Divine, Ph.D., Senior Planner. Imperial, CA.
12. Imperial Irrigation District. (2017). [Temporary Land Following Conversion Policy. \(TLFCP\)](#).
- 13.
14. Imperial Irrigation District. (2018). [2017 IID SWRCB Report](#).
15. United States Bureau of Reclamation Lower Colorado Region Website: [Boulder Canyon Operations Office – Programs and Activities](#), Lower Colorado River Water Accounting, Water Accounting Reports (1964 - 2015). Compilation of Records in Accordance with Article V of the Decree of the Supreme Court of the United States in Arizona v. California Dated March 9, 1964: Calendar Years 1964 - 2015 Boulder City, NV.

ATTACHMENTS

Attachments

Attachment A: IID Interim Water Supply Policy for Non-Agricultural Projects

(This page intentionally left blank)

PC ORIGINAL PKG

ATTACHMENT A: IID INTERIM WATER SUPPLY POLICY FOR NON-AGRICULTURAL PROJECTS²⁵

1.0 Purpose.

Imperial Irrigation District (the District) is developing an Integrated Water Resources Management Plan (IWRMP)²⁶ that will identify and recommend potential programs and projects to develop new water supplies and new storage, enhance the reliability of existing supplies, and provide more flexibility for District water department operations, all in order to maintain service levels within the District's existing water service area. The first phase of the IWRMP is scheduled to be completed by the end of 2009 and will identify potential projects, implementation strategies and funding sources. Pending development of the IWRMP, the District is adopting this Interim Water Supply Policy (IWSP) for Non-Agricultural Projects, as defined below, in order to address proposed projects that will rely upon a water supply from the District during the time that the IWRMP is still under development. It is anticipated that this IWSP will be modified and/or superseded to take into consideration policies and data developed by the IWRMP.

2.0 Background.

The IWRMP will enable the District to more effectively manage existing water supplies and to maximize the District's ability to store or create water when the available water supplies exceed the demand for such water. The stored water can be made available for later use when there is a higher water demand. Based upon known pending requests to the District for water supply assessments/verifications and pending applications to the County of Imperial for various Non-Agricultural Projects, the District currently estimates that up to 50,000 acre feet per year (AFY) of water could potentially be requested for Non-Agricultural Projects over the next ten to twenty years. Under the IWRMP the District shall evaluate the projected water demand of such projects and the potential means of supplying that amount of water. This IWSP currently designates up to 25,000 AFY of water for potential Non-Agricultural Projects within IID's water service area. Proposed Non-Agricultural projects may be required to pay a Reservation Fee, further described below. The reserved water shall be available for other users until such Non-Agricultural projects are implemented and require the reserved water supply. This IWSP shall remain in effect pending the approval of further policies that will be adopted in association with the IWRMP.

3.0 Terms and Definitions.

3.1 Agricultural Use. Uses of water for irrigation, crop production and leaching.

²⁵ IID Board Resolution 31-2009. Interim Water Supply Policy for New Non-Agricultural Projects. September 29, 2009. <[IID Interim Water Supply Policy for Non-Agricultural Projects](#)>

²⁶ The 2009 Draft IID IWRMP has been superseded by the October 2012 Imperial IRWMP, which incorporates the conditions of the IWSP by reference.

3.2 Connection Fee. A fee established by the District to physically connect a new Water User to the District water system.

3.3 Industrial Use. Uses of water that are not Agricultural or Municipal, as defined herein, such as manufacturing, mining, cooling water supply, energy generation, hydraulic conveyance, gravel washing, fire protection, oil well re-pressurization and industrial process water.

3.4 Municipal Use. Uses of water for commercial, institutional, community, military, or public water systems, whether in municipalities or in unincorporated areas of Imperial County.

3.5 Mixed Use. Uses of water that involve a combination of Municipal Use and Industrial Use.

3.6 Non-Agricultural Project. Any project which has a water use other than Agricultural Use, as defined herein.

3.7 Processing Fee. A fee charged by the District Water Department to reimburse the District for staff time required to process a request for water supply for a Non-Agricultural Project.

3.8 Reservation Fee. A non-refundable fee charged by the District when an application for water supply for a Non-Agricultural Project is deemed complete and approved. This fee is intended to offset the completion of the application to start-up of construction of the proposed project and/or execution of a water supply agreement. The initial payment of the Reservation Fee will reserve the projected water supply for up to two years. The Reservations Fee is renewable for up to two additional two-year periods upon payment of an additional fee for each renewal.

3.9 Water Supply Development Fee. An annual fee charged to some Non-Agricultural Projects by the District, as further described in Section 5.2 herein. Such fees shall assist in funding IWRMP or related water supply projects,

3.10 Water User. A person or entity that orders or receives water service from the District.

4.0. CEQA Compliance.

4.1 The responsibility for CEQA compliance for new development projects within the unincorporated area of the County of Imperial attaches to the County of Imperial or, if the project is within the boundaries of a municipality, the particular municipality, or if the project is subject to the jurisdiction of another agency, such as the California Energy Commission, the particular agency. The District will coordinate with the County of Imperial, relevant municipality, or other agency to help ensure that the water supply component of their respective general plans is comprehensive and based upon current information. Among other things, the general plans should assess the direct, indirect and cumulative potential impacts on the environment of using currently available water supplies for new industrial, municipal, commercial and/or institutional uses instead of the historical use of that water for agriculture. Such a change in land use, and the associated water use, could potentially impact land uses, various aquatic and terrestrial species, water quality, air quality and the conditions of drains, rivers and the Salton Sea.

4.2 When determining whether to approve a water supply agreement for any Non-Agricultural Project pursuant to this IWSP, the District will consider whether potential environmental and water supply impacts of such proposed projects have been adequately assessed, appropriate mitigation has been developed and appropriate conditions have been adopted by the relevant land use permitting/approving agencies, before the District approves any water supply agreement for such project.

5.0. Applicability of Fees for Non-Agricultural Projects.²⁷

5.1 Pursuant to this Interim Water Supply Policy, applicants for water supply for a Non-Agricultural Project shall be required to pay a Processing Fee and may be required to pay a Reservation Fee as shown in Table A. All Water Users shall also pay the applicable Connection Fee, if necessary, and regular water service fees according to the District water rate schedules, as modified from time to time.

5.2 A Non-Agricultural Project may also be subject to an annual Water Supply Development Fee, depending upon the nature, complexity, and water demands of the proposed project. The District will determine whether a proposed Non-Agricultural Project is subject to the Water Supply Development Fee for water supplied pursuant to this IWSP as follows:

5.2.1. A proposed project that will require water for a Municipal Use shall be subject to an annual Water Supply Development Fee as set forth in Table B if the projected water demand for the project is in excess of the project's estimated population multiplied by the District-wide per capita usage. Municipal Use projects without an appreciable residential component will be analyzed under sub-section 5.2.3.

5.2.2. A proposed project that will require water for an Industrial Use located in an unincorporated area of the County of Imperial shall be subject to an annual Water Supply Development Fee as set forth in Table B.

5.2.3. The applicability of the Water Supply Development Fee set forth in Table B to Mixed Use projects, Industrial Use projects located within a municipality, or Municipal Use projects without an appreciable residential component, will be determined by the District on a case-by-case basis, depending upon the proportion of types of land uses and the water demand proposed for the project.

5.3. A proposed Water User for a Non-Agricultural Projects may elect to provide some or all of the required water supply by paying for and implementing some other means of providing water in a manner approved by the District, such as conservation projects, water storage projects and/or use of an alternative source of supply, such as recycled water or some source of water other than from the District water supply. Such election shall require consultation with the District regarding the details of such alternatives and a determination by the District, in its reasonable discretion, concerning how much credit, if any, should be given for such alternative water supply as against the project's water demand for purposes of determining the annual Water Supply Development Fee for such project.

²⁷ The most recent fee schedules can be found in a link at IID/Water/ Municipal, Industrial and Commercial Customers; or visit by URL at [Imperial Irrigation District : Water Rate Schedules](#)

5.4 The District Board shall have the right to modify the fees shown on Tables A and B from time to time.

6. Water Supply Development Fees collected by the District under this IWSP shall be accounted for independently, including reasonable accrued interest, and such fees shall only be used to help fund IWRMP or related District water supply projects.

7. Any request for water service for a proposed Non-Agricultural Project that meets the criteria for a water supply assessment pursuant to Water Code Sections 10910-10915 or a water supply verification pursuant to Government Code Section 66473.7 shall include all information required by Water Code Sections 10910 –10915 or Government Code Section 66473.7 to enable the District to prepare the water supply assessment or verification. All submittals should include sufficient detail and analysis regarding the project's water demands, including types of land use and per capita water usage, necessary to make the determinations outlined in Section 5.2.

8. Any request for water service for a proposed Non-Agricultural Project that does not meet the criteria for a water supply assessment pursuant to Water Code Section 10910-10915 or water supply verification pursuant to Government Code Section 66473.7 shall include a complete project description with a detailed map or diagram depicting the footprint of the proposed project, the size of the footprint, projected water demand at full implementation of the project and a schedule for implementing water service. All submittals should include sufficient detail and analysis regarding the project's water demands, including types of land use and per capita water usage, necessary to make the determinations outlined in Section 5.2.

9. All other District rules and policies regarding a project applicant or Water User's responsibility for paying connection fees, costs of capital improvements and reimbursing the District for costs of staff and consultant's time, engineering studies and administrative overhead required to process and implement projects remain in effect.

10. Municipal Use customers shall be required to follow appropriate water use efficiency best management practices (BMPs), including, but not limited to those established by the California Urban Water Conservation Council BMP's (see <http://www.cuwcc.org/mou/exhibit-1-bmp-definitions-schedules-requirements.aspx>), or other water use efficiency standards, adopted by the District or local government agencies.

11. Industrial Use customers shall be required to follow appropriate water use efficiency BMP's, including but not limited to those established by the California Urban Water Conservation Council and California Energy Commission, as well as other water use efficiency standards, adopted by the District or local government agencies.

12. The District may prescribe additional or different BMPs for certain categories of Municipal and Industrial Water Users.

(This page intentionally left blank)

Energy Impact Assessment

Vega SES 4 Solar Energy Storage Project

County of Imperial, California

Prepared For:

Vega SES 4, LLC
604 Sutter Street
Suite 250
Folsom, California 95630

February 2021



ECORP Consulting, Inc.
ENVIRONMENTAL CONSULTANTS

PC ORIGINAL PKG

CONTENTS

1.0 INTRODUCTION 1

 1.1 Project Overview..... 1

 1.2 Project Location 1

 1.3 Applicable Land Use Regulations 1

 1.4 Project Site Access..... 2

 1.5 Project Construction 2

2.0 Energy Consumption..... 4

 2.1 Energy Types and Sources..... 4

 2.1.1 Energy Consumption 4

 2.2 Regulatory Framework..... 5

 2.2.1 State..... 5

 Renewable Energy Sources (Renewable Portfolio Standards) 6

 2.3 Energy Consumption Impact Assessment..... 6

 2.3.1 Thresholds of Significance 6

 2.3.2 Methodologie 7

 2.3.3 Impact Analysis..... 7

 2.4 Energy Consumption 7

3.0 REFERENCES..... 10

LIST OF TABLES

Table 2-1. Electricity Consumption in Imperial County 2015-2019..... 4

Table 2-2. Natural Gas Consumption in Imperial County 2015-2019 5

Table 2-3. Automotive Fuel Consumption in Imperial County 2016-2020..... 5

Table 2-4. Proposed Project Energy and Fuel Consumption 8

LIST OF FIGURES

Figure 1. Project Location and Vicinity..... 3

ATTACHMENTS

Attachment A - Energy Consumption Modeling Output

LIST OF ACRONYMS AND ABBREVIATIONS

APNs	Assessor's Parcel Numbers
CalEEMod	California Emissions Estimator Model
CAISO	California Independent System Operator
CARB	California Air Resources Board
CEC	California Energy Commission
CPUC	California Public Utility Commission
EPS	Emissions Performance Standard
HSAT	Horizontal Single-Axis Tracker
IID	Imperial Irrigation District
kWh	Kilowatt-Hours
MW	Megawatt
mWh	Megawatt Hour
PV	Photovoltaic
Project	Vega SES 4 Solar Energy Storage Project
RPS	Renewables Portfolio Standard

1.0 INTRODUCTION

This report documents the results of an Energy Impact Assessment completed for the Vega SES 4 Solar Energy Storage Project (Project), which includes the construction of a nominal 100-megawatt (MW) alternating current solar photovoltaic (PV) energy generation system with an integrated 100 MW battery storage project on approximately 531.53 acres of land in Imperial County, California. This report was prepared to analyze the potential direct and indirect environmental impacts associated with Project energy consumption, including the depletion of nonrenewable resources (oil, natural gas, coal, etc.) during the construction and operational phases. The impact analysis focuses on the four sources of energy that are relevant to the proposed Project: electricity, natural gas, the equipment-fuel necessary for Project construction, and the automotive fuel necessary for Project operations.

1.1 Project Overview

The Project proposes to construct a nominal 100 MW alternative current PV energy generation system, accompanied by a 100 MW battery storage, utilizing either thin film or crystalline solar PV technology modules mounted either on fixed frames or horizontal single-axis tracker (HSAT) systems. The fixed frame PV module arrays would be mounted on racks that would be supported by driven piles. The individual PV systems would be arranged in large arrays by placing them in columns spaced approximately ten feet apart to maximize operational performance and to allow access for panel cleaning and maintenance.

1.2 Project Location

The Project site is an approximately 531.53-acre site located between the California/Mexico border and the All-American Canal (Aqueduct), on the California side in southcentral Imperial County (County) (see Figure 1). The Project site is located approximately 1.92 miles southeast of the Bonds Corner Road/East Cedar Street/California State Route 98 intersection near the unincorporated community of Bonds Corner. The Project would be located on Imperial County Assessor's Parcel Numbers (APNs) 059-300-015-000 (approximately 301.73 acres), 059-300-017-000 (approximately 148.88 acres) and 059-290-010-000 (approximately 80.92 acres). The irregular shaped site is bound by undeveloped agricultural land to the south, west and east, and the Aqueduct running southwest on the northern border of the proposed Project site. The Project site is currently characterized by flat and undeveloped agricultural land.

1.3 Applicable Land Use Regulations

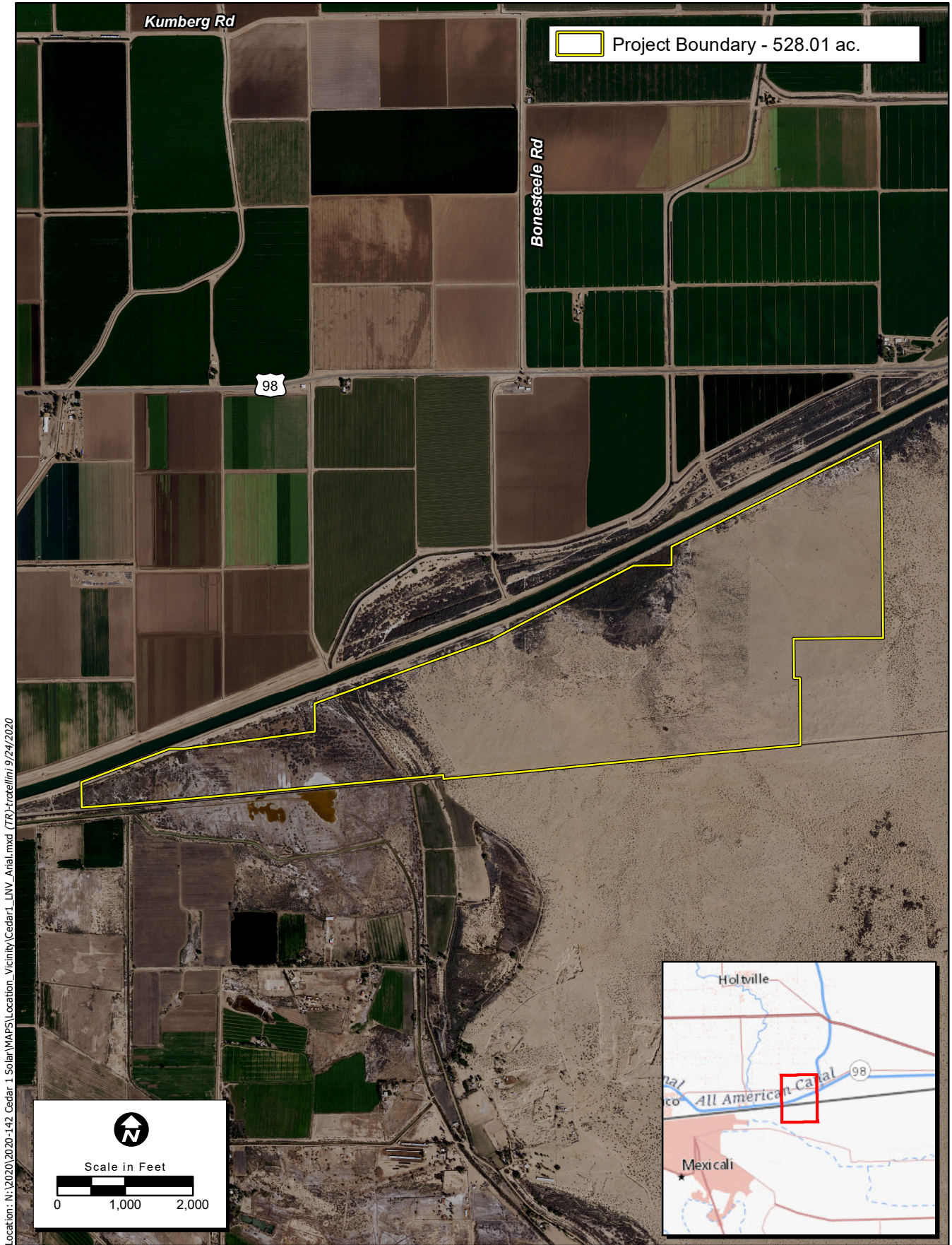
All three of the Project area parcels are designated as "Agriculture" in the Imperial County General Plan and are zoned A-3-RE (Heavy Agriculture with a Renewable Energy Overlay-areas that are suitable for agricultural land uses; to prevent the encroachment of incompatible uses onto and within agricultural lands; and to prohibit the premature conversion of such lands to non-agricultural uses). Pursuant to Section 91703.02 (*Conditional Use Permits*), Renewable Energy Projects must be located within the Renewable Energy Overlay Zone and may be permitted only through the issuance of a Conditional Use Permit (CUP) as approved by the Approving Authority unless otherwise allowed by applicable law. At present, the Project is located within the Renewable Energy Zone.

1.4 Project Site Access

The Project site would include one primary access driveway, currently contemplated across the East Highline Check of the Aqueduct, in the far northeastern corner of the Project area and a secondary access driveway (if required) with a to-be-determined location. This driveway would be provided with a minimum of 30-foot double swing gates with "Knox Box" for keyed entry. Internal to the Project site up to 30-foot wide roads would be provided between the PV arrays, as well as around the perimeter of each Project site inside the perimeter security fence to provide access to all areas of each site for maintenance and emergency vehicles.

1.5 Project Construction

Construction activities would primarily involve demolition and grubbing; grading of the Project area to establish access roads and pads for electrical equipment (inverters and step-up transformers); trenching for underground electrical collection lines; and the installation of solar equipment and security fencing. The construction of the site is estimated to take 12-18 months and would begin in 2022. A temporary, portable construction supply container would be located at the Project site at the beginning of construction and removed at the end of construction. The number of on-site construction workers for the solar project facilities is not expected to exceed 150 workers at any one time. The number of on-site construction workers for the battery storage facility and the substation is not expected to exceed 100 workers at any one time. Onsite parking would be provided for all construction workers.



Location: N:\2020\2020-142_Cedar_1_Solar\WAPS\Location_Vicinity\Cedar1_LINV_Arial.mxd (TR)-truelin\9/24/2020

Map Date: 9/24/2020
 Service Layer Credits:
 Photo Source: NAIP (2018)

Figure 1. Project Location and Vicinity

2020-142 Vega SES 4

2.0 ENERGY CONSUMPTION

2.1 Energy Types and Sources

California relies on a regional power system comprised of a diverse mix of natural gas, renewable, hydroelectric, and nuclear generation resources. Natural gas provides California with a majority of its electricity followed by renewables, large hydroelectric and nuclear (California Energy Commissions [CEC] 2020). Imperial Irrigation District (IID), the sixth largest electrical utility in California serving more than 150,000 customers in the Imperial Valley and parts of Riverside and San Diego counties, provides electrical services to the Project area. IID controls more than 1,100 megawatts of energy derived from a diverse resource portfolio that includes its own generation, and long- and short-term power purchases. Located in a region with abundant sunshine, enviable geothermal capacity, wind and other renewable potential, IID has met or exceeded all Renewable Portfolio Standard requirements to date, procuring renewable energy from diverse sources, including biomass, biowaste, geothermal, hydroelectric, solar and wind.

The Southern California Gas Company provides natural gas services to Imperial County. As the nation's largest natural gas distribution utility, the Southern California Gas Company delivers natural gas energy to 21.6 million consumers through 5.9 million meters in more than 500 communities. The Southern California Gas Company's service territory encompasses approximately 20,000 square miles throughout Central and Southern California, from Visalia to the Mexican border.

2.1.1 Energy Consumption

Electricity use is measured in kilowatt-hours (kWh), and natural gas use is measured in therms. Vehicle fuel use is typically measured in gallons (e.g. of gasoline or diesel fuel), although energy use for electric vehicles is measured in kWh.

The electricity consumption associated with all uses in Imperial County from 2015 to 2019 is shown in Table 2-1. As indicated, the demand has remained constant since 2015.

Year	Electricity Consumption (kilowatt hours)
2019	1,415,790,908
2018	1,467,590,638
2017	1,445,167,336
2016	1,440,493,016
2015	1,419,088,130

Source: CEC 2019

The natural gas consumption associated with all uses in Imperial County from 2015 to 2019 is shown in Table 2-2. As indicated, the demand has increased since 2015.

Table 2-2. Natural Gas Consumption in Imperial County 2015-2019	
Year	Natural Gas Consumption (therms)
2019	42,914,053
2018	38,729,625
2017	40,442,318
2016	36,089,854
2015	31,494,256

Source: CEC 2019

Automotive fuel consumption in Imperial County from 2016 to 2020 is shown in Table 2-3. Fuel consumption has decreased between 2016 and 2020.

Table 2-3. Automotive Fuel Consumption in Imperial County 2016-2020	
Year	Total Fuel Consumption (gallons)
2020	196,177,597
2019	198,822,094
2018	201,793,138
2017	204,312,157
2016	208,822,214

Source: California Air Resources Board (CARB) 2017

2.2 Regulatory Framework

2.2.1 State

Executive Order B-55-18

In September 2018 Governor Jerry Brown Signed Executive Order (EO) B-55-18, which establishing a new statewide goal “to achieve carbon neutrality as soon as possible, and no later than 2045, and achieve and maintain net negative emissions thereafter.” Carbon neutrality refers to achieving a net zero carbon dioxide emissions. This can be achieved by reducing or eliminating carbon emissions, balancing carbon emissions with carbon removal, or a combination of the two. This goal is in addition to existing statewide targets for GHG emission reduction. EO B-55-18 requires the California Air Resource Board (CARB) to “work with relevant state agencies to ensure future Scoping Plans identify and recommend measures to achieve the carbon neutrality goal.

Senate Bill 1368

On September 29, 2006, Governor Arnold Schwarzenegger signed into law Senate Bill (SB) 1368 (Perata, Chapter 598, Statutes of 2006). The law limits long-term investments in baseload generation by the state's utilities to those power plants that meet an emissions performance standard jointly established by the CEC and the California Public Utilities Commission (CPUC).

The CEC has designed regulations that:

- Establish a standard for baseload generation owned by, or under long-term contract to, publicly owned utilities, of 1,100 pounds carbon dioxide per megawatt hour (mWh). This would encourage the development of power plants that meet California's growing energy needs while minimizing their emissions of greenhouse gas.
- Require posting of notices of public deliberations by publicly owned utilities on long-term investments on the CEC website. This would facilitate public awareness of utility efforts to meet customer needs for energy over the long term while meeting the State's standards for environmental impact.
- Establish a public process for determining the compliance of proposed investments with the emissions performance standard (EPS) (Perata, Chapter 598, Statutes of 2006).

Renewable Energy Sources (Renewable Portfolio Standards)

Established in 2002 under SB 1078, and accelerated by SB 107 (2006) and SB 2 (2011), California's Renewables Portfolio Standard (RPS) obligates investor-owned utilities, energy service providers, and community choice aggregators to procure 33 percent of their electricity from renewable energy sources by 2020. Eligible renewable resources are defined in the 2013 RPS to include biodiesel; biomass; hydroelectric and small hydro (30 megawatts or less); Los Angeles Aqueduct hydro power plants; digester gas; fuel cells; geothermal; landfill gas; municipal solid waste; ocean thermal, ocean wave, and tidal current technologies; renewable derived biogas; multi-fuel facilities using renewable fuels; solar photovoltaic; solar thermal electric; wind; and other renewables that may be defined later. Governor Jerry Brown signed SB 350 on October 7, 2015, which expands the RPS by establishing a goal of 60 percent of the total electricity sold to retail customers in California per year by December 31, 2030. In addition, SB 350 includes the goal to double the energy efficiency savings in electricity and natural gas final end uses (such as heating, cooling, lighting, or class of energy uses upon which an energy efficiency program is focused) of retail customers through energy conservation and efficiency. The bill also requires the CPUC, in consultation with the CEC, establish efficiency targets for electrical and gas corporations consistent with this goal. SB 350 also provides for the transformation of the California Independent System Operator (CAISO) into a regional organization to promote the development of regional electricity transmission markets in the western states and to improve the access of consumers served by the CAISO to those markets, pursuant to a specified process. In 2018, SB 100 was signed by Governor Brown, codifying a goal of 60 percent renewable procurement by 2030 and 100 percent by 2045 Renewables Portfolio Standard.

2.3 Energy Consumption Impact Assessment

2.3.1 Thresholds of Significance

The impact analysis provided below is based on the following CEQA Guidelines Appendix G thresholds of significance. The Project would result in a significant impact to energy if it would do any of the following:

- 1) Result in potentially significant environmental impact due to wasteful, inefficient, or unnecessary consumption of energy resources, during project construction or operation.

- 2) Conflict with or obstruct a state or local plan for renewable energy or energy efficiency.

The impact analysis focuses on the four sources of energy that are relevant to the proposed Project: electricity, natural gas, the equipment fuel necessary for Project construction, and the automotive fuel necessary for Project operations. Addressing energy impacts requires an agency to make a determination as to what constitutes a significant impact. There are no established thresholds of significance, statewide or locally, for what constitutes a wasteful, inefficient, and unnecessary consumption of energy for a proposed land use. For the purposes of this analysis, the amount of electricity and natural gas estimated to be consumed by the Project are quantified and compared to that consumed by all land uses in Imperial County. Similarly, the amount of fuel necessary for Project construction and operations is calculated and compared to that consumed in Imperial County.

2.3.2 Methodology

Levels of construction and operational related energy consumption estimated to be consumed by the Project include the number of kWh of electricity, therms of natural gas and gallons of gasoline. Modeling was based on Project specific information such as construction timing and equipment as well as site operations. Energy consumption estimates were calculated using the California Emissions Estimator Model (CalEEMod), version 2016.3.2. CalEEMod is a statewide land use computer model designed to quantify resources associated with both construction and operations from a variety of land use projects.

2.3.3 Impact Analysis

2.4 Energy Consumption

The Project is proposing the development of a 100 MW alternating current PV energy generation system with an integrated 100 MW battery on approximately 531.53 acres of land. Operations of the proposed Project would not result in the consumption of electricity or natural gas and thus, would not contribute to the County wide usage and would directly support the RPS goal of increasing the percentage of electricity procured from renewable sources.

Therefore, this impact analysis focuses on the two sources of energy that are most relevant to the Project: the equipment fuel necessary for construction and the automotive fuel necessary for ongoing maintenance activities. The amount of total construction-related fuel use was estimated using ratios provided in the Climate Registry's General Reporting Protocol for the Voluntary Reporting Program, Version 2.1. The amount of operational fuel use was estimated using CARB's EMFAC2017 computer program, which provides projections for typical daily fuel usage in Imperial County. This analysis conservatively assumes that all of the automobile trips projected to arrive at the Project during operations would be new to Imperial County.

Energy consumption associated with the proposed Project is summarized in Table 2-4. Project increases in automotive fuel consumption are compared with the countywide fuel consumption in 2020, the most recent full year of data.

Table 2-4. Proposed Project Energy and Fuel Consumption		
Energy Type	Annual Energy Consumption	Percentage Increase Countywide
Electricity Consumption ¹	0 kilowatt-hours	0.00000 percent
Natural Gas ¹	0 therms	0.00000 percent
<i>Automotive Fuel Consumption</i>		
Project Construction 2022 ²	77,931 gallons	0.03971 percent
Project Construction 2023 ²	45,123 gallons	0.02299 percent
Project Operations ³	128 gallons	0.00006 percent

Source: ¹CalEEMod; ²Climate Registry 2016; ³EMFAC2017 (CARB 2017)

Notes: The Project increases in electricity and natural gas consumption are compared with all uses in Imperial County in 2019, the latest data available. The Project increases in automotive fuel consumption are compared with the countywide fuel consumption in 2020, the most recent full year of data.

Fuel necessary for Project construction would be required for the operation and maintenance of construction equipment and the transportation of materials to the Project site. The fuel expenditure necessary to construct the solar facility and infrastructure would be temporary, lasting only as long as Project construction. As indicated in Table 2-4, the Project’s gasoline fuel consumption during the one-time construction period is estimated to be 77,931 gallons during 2022 construction and 45,123 gallons during 2023 construction. This would increase the annual countywide gasoline fuel use in the county by 0.03971 percent and 0.02299 percent respectively. As such, Project construction would have a nominal effect on local and regional energy supplies. No unusual Project characteristics would necessitate the use of construction equipment that would be less energy efficient than at comparable construction sites in the region or the state. Construction contractors would purchase their own gasoline and diesel fuel from local suppliers and would judiciously use fuel supplies to minimize costs due to waste and subsequently maximize profits. Additionally, construction equipment fleet turnover and increasingly stringent state and federal regulations on engine efficiency combined with state regulations limiting engine idling times and requiring recycling of construction debris, would further reduce the amount of transportation fuel demand during Project construction. For these reasons, it is expected that construction fuel consumption associated with the Project would not be any more inefficient, wasteful, or unnecessary than other similar development projects of this nature.

Once construction is completed the Project would be remotely controlled. No employees would be based at the Project site. The only operational emissions associated with the Project would be associated with motor vehicle use for routine maintenance work and site security as well as panel upkeep and cleaning. A conservative estimate of one vehicle trip per day generated by the Project was assumed. This is a conservative estimate as most days would require no operational related vehicle trips. As indicated in Table 2-4, this would estimate to a consumption of approximately 128 gallons of automotive fuel per year, which would increase the annual countywide automotive fuel consumption by 0.00006 percent. Fuel consumption associated with both the construction equipment needed to construction the Project and the vehicle trips generated by the Project during ongoing maintenance activities would not be considered inefficient, wasteful, or unnecessary in comparison to other similar developments in the region.

State and Local Plans for Renewable Energy/Energy Efficiency

The purpose of the proposed Project is the construction of a renewable energy and storage facility in Imperial County. Once in operation, it will decrease the need for energy from fossil fuel-based power plants in the state. The result would be a net increase in electricity resources available to the regional grid, generated from a renewable source. Therefore, the Project would directly support the RPS goal of increasing the percentage of electricity procured from renewable sources. Additionally, the Project would also be consistent with the County's General Plan Conservation and Open Space Element, Objective 9.2 which encourages renewable energy developments. Therefore, the Project would directly support state and local plans for renewable energy development.

3.0 REFERENCES

CARB. 2017. EMFAC2017 Web Database Emissions Inventory. <https://www.arb.ca.gov/emfac/2017/>.

CEC. 2020. 2019 Total System Electric Generations in Gigawatt Hours.

<https://www.energy.ca.gov/data-reports/energy-almanac/california-electricity-data/2019-total-system-electric-generation>

_____. 2019. California Energy Consumption Database. <http://www.ecdms.energy.ca.gov/Default.aspx>.

Climate Registry. 2016. *General Reporting Protocol for the Voluntary Reporting Program version 2.1*.

January 2016. <http://www.theclimateregistry.org/wp-content/uploads/2014/11/General-Reporting-Protocol-Version-2.1.pdf>

LIST OF ATTACHMENTS

Attachment A - Energy Consumption Modeling Output

Action	Carbon Dioxide Equivalents (CO ₂ e) in Metric Tons ¹	Conversion of Metric Tons to Kilograms ²	Construction Equipment Emission Factor ²	Total Gallons of Fuel Consumed
Project Construction	791	791000	10.15	77,931
		Per Climate Registry Equation 13e	Per Climate Registry Equation 13e	
	Per CalEEMod Output Files.			

Total Gallons Consumed During 2022 Project Construction:

77,931

Notes:

Fuel used by all construction equipment, including vehicle hauling trucks, assumed to be diesel.

Sources:

¹ECORP Consulting, 2021.

²Climate Registry. 2016. *General Reporting Protocol for the Voluntary Reporting Program version 2.1*. January 2016.
<http://www.theclimateregistry.org/wp-content/uploads/2014/11/General-Reporting-Protocol-Version-2.1.pdf>

**Proposed Project
Total Construction-Related
and Operational
Gasoline Usage**

Action	Carbon Dioxide Equivalents (CO₂e) in Metric Tons¹	Conversion of Metric Tons to Kilograms²	Construction Equipment Emission Factor²	Total Gallons of Fuel Consumed
Project Construction	458	458000	10.15	45,123
		<small>Per Climate Registry Equation 13e</small>	<small>Per Climate Registry Equation 13e</small>	
	<small>Per CalEEMod Output Files.</small>			

Total Gallons Consumed During 2023 Project Construction: 45,123

Notes:
Fuel used by all construction equipment, including vehicle hauling trucks, assumed to be diesel.

Sources:
¹ECORP Consulting, 2021.

²Climate Registry. 2016. *General Reporting Protocol for the Voluntary Reporting Program version 2.1*. January 2016.
<http://www.theclimateregistry.org/wp-content/uploads/2014/11/General-Reporting-Protocol-Version-2.1.pdf>

Total Gallons During Project Operations³

Area	Sub-Area	Cal. Year	Season	Veh_tech	EMFAC 2011 Category	Fuel_GAS Output	Daily Total	ANNUAL TOTAL
Sub-Areas	Imperial	2023	Annual	All Vehicles	All Vehicles ⁴	0.000350094	0.350093775	127.8

Sources:
³Californai Air Resource Board. 2017. EMFAC2017 Mobile Emissions Model.

Notes:
⁴Excluding Heavy-Duty Highway Trucks, T6 Agricultural Truck, T6 Instate Construction (heavy and small), T7 Agricultural Truck, T7 CAIRP Construction, T7 Single Construction, T7 Tractor Truck, and T7 Tractor Construction

Final Environmental Impact Report

VEGA SES 4 Solar Energy Project

SCH No. 2021050018

Imperial County, California

February 2023

Prepared for

County of Imperial
801 Main Street
El Centro, California 92243

Prepared by

HDR
591 Camino de la Reina
Suite 300
San Diego, California 92108

This page is intentionally blank.



Table of Contents

0.1	Introduction and Summary	0.1-1
0.2	Response to Comments	0.2-1
0.3	Errata to the Draft EIR.....	0.3-1
0.4	Mitigation Monitoring and Reporting Program.....	0.4-1
	Executive Summary	ES-1
	Project Overview	ES-1
	Purpose of an EIR	ES-1
	Eliminated from Further Review in Notice of Preparation	ES-1
	Summary of Significant Impacts and Mitigation Measures that Reduce or Avoid the Significant Impacts	ES-2
	Areas of Controversy and Issues to be Resolved	ES-2
	Project Alternatives	ES-27
	Environmentally Superior Alternative	ES-29
1	Introduction.....	1-1
	1.1 Overview of the Proposed Project.....	1-1
	1.1.1 Agency Roles and Responsibilities	1-1
	1.2 Relationship to Statutes, Regulations, and Other Plans	1-3
	1.2.1 County of Imperial General Plan and Land Use Ordinance.....	1-3
	1.2.2 Renewables Portfolio Standard Program.....	1-3
	1.2.3 Senate Bill 32	1-4
	1.2.4 Title 17 California Code of Regulations, Subchapter 10, Article 2, Sections 95100 et seq.....	1-4
	1.2.5 Federal Clean Air Act	1-4
	1.2.6 Imperial County Air Pollution Control District	1-5
	1.2.7 Federal Clean Water Act (33 United States Code Sections 1251–1387).....	1-5
	1.2.8 Federal Clean Water Act and California Porter-Cologne Water Quality Control Act.....	1-5
	1.2.9 Federal Endangered Species Act	1-5
	1.2.10 National Historic Preservation Act.....	1-6
	1.2.11 California Endangered Species Act	1-6
	1.2.12 California Lake and Streambed Program (Fish and Game Code Section 1602)	1-6
	1.3 Purpose of an EIR	1-6
	1.4 EIR Process	1-6
	1.4.1 Availability of Reports.....	1-6
	1.4.2 Public Participation Opportunities/Comments and Coordination	1-7
	1.4.3 Environmental Topics Addressed	1-8
	1.4.4 Areas of Controversy and Issues to be Resolved.....	1-8
	1.4.5 Document Organization	1-8
2	Project Description	2-1
	2.1 Project Location.....	2-1
	2.1.1 Solar Energy Facility	2-1
	2.1.2 Battery Storage System	2-1
	2.1.3 Gen-Tie Line.....	2-4
	2.1.4 Renewable Energy Overlay Zone	2-4
	2.2 Project Objectives	2-4

2.3	Project Characteristics	2-4
2.3.1	Photovoltaic Panels/Solar Arrays	2-7
2.3.2	Electrical Power System	2-7
2.3.3	Interconnection Facilities	2-7
2.3.4	Gen-Tie	2-8
2.3.5	Battery Energy Storage System	2-8
2.3.6	Security	2-8
2.3.7	Site Access	2-9
2.3.8	Fire Protection/Fire Suppression	2-9
2.4	Site Construction	2-10
2.4.1	Construction Activities	2-10
2.4.2	Heavy Construction Equipment Access	2-10
2.4.3	Parking and Staging Areas	2-10
2.4.4	Water Use	2-16
2.5	Operations and Maintenance	2-16
2.5.1	Water Use	2-16
2.6	Restoration of the Project Site	2-16
2.7	Required Project Approvals	2-17
2.7.1	Imperial County	2-17
2.7.2	Discretionary Actions and Approvals by Other Agencies	2-18
2.7.3	Memorandum of Understanding – U.S. Border Patrol	2-18
3	Environmental Analysis, Impacts, and Mitigation	3.1-1
3.1	Introduction to Environmental Analysis	3.1-1
3.1.1	Organization of Issue Areas	3.1-1
3.1.2	Format of the Impact Analysis	3.1-1
3.2	Aesthetics and Visual Resources	3.2-1
3.2.1	Existing Conditions	3.2-1
3.2.2	Regulatory Setting	3.2-2
3.2.3	Impacts and Mitigation Measures	3.2-3
3.2.4	Decommissioning/Restoration and Residual Impacts	3.2-7
3.3	Agricultural Resources	3.3-1
3.3.1	Existing Conditions	3.3-1
3.3.2	Regulatory Setting	3.3-1
3.3.3	Impacts and Mitigation Measures	3.3-8
3.3.4	Decommissioning/Restoration and Residual Impacts	3.3-13
3.4	Air Quality	3.4-1
3.4.1	Existing Conditions	3.4-1
3.4.2	Regulatory Setting	3.4-5
3.4.3	Impacts and Mitigation Measures	3.4-11
3.4.4	Decommissioning/Restoration and Residual Impacts	3.4-23
3.5	Biological Resources	3.5-1
3.5.1	Existing Conditions	3.5-1
3.5.2	Regulatory Setting	3.5-30
3.5.3	Impacts and Mitigation Measures	3.5-34
3.5.4	Decommissioning/Restoration and Residual Impacts	3.5-45
3.6	Cultural Resources	3.6-1
3.6.1	Existing Conditions	3.6-1
3.6.2	Regulatory Setting	3.6-10
3.6.3	Impacts and Mitigation Measures	3.6-14
3.6.4	Decommissioning/Restoration and Residual Impacts	3.6-19
3.7	Geology and Soils	3.7-1



3.7.1	Existing Conditions	3.7-1
3.7.2	Regulatory Setting	3.7-9
3.7.3	Impacts and Mitigation Measures	3.7-12
3.7.4	Decommissioning/Restoration and Residual Impacts	3.7-18
3.8	Greenhouse Gas Emissions	3.8-1
3.8.1	Existing Conditions	3.8-1
3.8.2	Regulatory Setting	3.8-4
3.8.3	Impacts and Mitigation Measures	3.8-9
3.8.4	Decommissioning/Restoration and Residual Impacts	3.8-14
3.9	Hazards and Hazardous Materials	3.9-1
3.9.1	Existing Conditions	3.9-1
3.9.2	Regulatory Setting	3.9-3
3.9.3	Impacts and Mitigation Measures	3.9-7
3.9.4	Decommissioning/Restoration and Residual Impacts	3.9-13
3.10	Hydrology/Water Quality	3.10-1
3.10.1	Existing Conditions	3.10-1
3.10.2	Regulatory Setting	3.10-3
3.10.3	Impacts and Mitigation Measures	3.10-10
3.10.4	Decommissioning/Restoration and Residual Impacts	3.10-19
3.11	Land Use Planning	3.11-1
3.11.1	Existing Conditions	3.11-1
3.11.2	Regulatory Setting	3.11-4
3.11.3	Impacts and Mitigation Measures	3.11-13
3.11.4	Decommissioning/Restoration and Residual Impacts	3.11-15
3.12	Noise and Vibration	3.12-1
3.12.1	Existing Conditions	3.12-1
3.12.2	Regulatory Setting	3.12-8
3.12.3	Impacts and Mitigation Measures	3.12-13
3.12.4	Decommissioning/Restoration and Residual Impacts	3.12-19
3.13	Transportation	3.13-1
3.13.1	Existing Conditions	3.13-1
3.13.2	Regulatory Setting	3.13-3
3.13.3	Impacts and Mitigation Measures	3.13-4
3.13.4	Decommissioning/Restoration and Residual Impacts	3.13-9
3.14	Tribal Cultural Resources	3.14-1
3.14.1	Existing Conditions	3.14-1
3.14.2	Regulatory Setting	3.14-1
3.14.3	Impacts and Mitigation Measures	3.14-4
3.14.4	Decommissioning/Restoration and Residual Impacts	3.14-6
3.15	Utilities and Service Systems	3.15-1
3.15.1	Existing Conditions	3.15-1
3.15.2	Regulatory Setting	3.15-1
3.15.3	Impacts and Mitigation Measures	3.15-4
3.15.4	Decommissioning/Restoration and Residual Impacts	3.15-5
4	Analysis of Long-Term Effects	4-1
4.1	Growth-Inducing Impacts	4-1
4.2	Significant Irreversible Environmental Changes	4-2
4.3	Unavoidable Adverse Impacts	4-3
5	Cumulative Impacts	5-1
5.1	Geographic Scope and Timeframe of the Cumulative Effects Analysis	5-1

5.2	Projects Contributing to Potential Cumulative Impacts	5-2
5.3	Cumulative Impact Analysis	5-2
5.3.1	Aesthetics and Visual Resources.....	5-5
5.3.2	Agricultural Resources	5-5
5.3.3	Air Quality	5-6
5.3.4	Biological Resources.....	5-8
5.3.5	Cultural Resources.....	5-9
5.3.6	Geology and Soils	5-10
5.3.7	Greenhouse Gas Emissions	5-10
5.3.8	Hazards/Hazardous Materials	5-11
5.3.9	Hydrology and Water Quality	5-12
5.3.10	Land Use Planning	5-12
5.3.11	Noise and Vibration	5-13
5.3.12	Transportation	5-13
5.3.13	Tribal Cultural Resources.....	5-14
5.3.14	Utilities/Service Systems.....	5-14
6	Effects Found Not Significant.....	6-1
6.1	Agriculture and Forestry Resources.....	6-1
6.1.1	Forestry Resources	6-1
6.2	Energy	6-1
6.2.1	Energy Types and Sources.....	6-1
6.2.2	Imperial County Energy Consumption	6-2
6.2.3	Proposed Project Energy and Fuel Consumption.....	6-3
6.2.4	Compliance with State or Local Plans for Renewable Energy or Energy Efficiency	6-4
6.3	Mineral Resources	6-4
6.4	Population and Housing	6-5
6.5	Public Services.....	6-5
6.6	Recreation	6-6
6.7	Utilities and Service Systems	6-6
6.8	Wildfire.....	6-7
7	Alternatives.....	7-1
7.1	Introduction.....	7-1
7.2	Criteria for Alternatives Analysis	7-1
7.3	Alternatives Considered but Rejected.....	7-2
7.3.1	Alternative Site	7-2
7.3.2	Original Site Plan Submittal	7-2
7.3.3	Original Access Route for Heavy Construction Equipment.....	7-2
7.4	Alternative 1: No Project/No Development Alternative	7-3
7.4.1	Environmental Impact of Alternative 1: No Project/No Development Alternative	7-3
7.5	Alternative 2: Reduced Project Site	7-7
7.5.1	Environmental Impact of Alternative 2: Reduced Project Site	7-7
7.6	Environmentally Superior Alternative	7-10
8	References	8-1
9	EIR Preparers and Persons and Organizations Contacted	9-1
9.1	EIR Preparers.....	9-1
9.2	Persons and Organizations Contacted	9-1



Tables

Table 0.2-1. VEGA SES 4 Solar Energy Project Draft EIR Comment Letters	0.1-2
Table 0.4-1. Mitigation Measures	0.4-3
Table ES-1. Summary of Project Impacts and Proposed Mitigation Measures	ES-3
Table ES-2. Comparison of Alternative Impacts to Proposed Project	ES-31
Table 2-1. Solar Energy Facility Site Assessor Parcel Numbers, Acreages, and Zoning	2-1
Table 3.2-1. Consistency with Applicable General Plan Conservation and Open Space Policies	3.2-2
Table 3.3-1. Imperial County Change in Agricultural Land Use Summary (2016 to 2018)	3.3-3
Table 3.3-2. Project Consistency with Applicable General Plan Agricultural Policies	3.3-6
Table 3.4-1. Criteria Air Pollutants – Summary of Common Sources and Effects	3.4-2
Table 3.4-2. Attainment Status of Criteria Pollutants in the Imperial County Portion of the Salton Sea Air Basin	3.4-3
Table 3.4-3. Summary of Local Ambient Air Quality Data	3.4-4
Table 3.4-4. Ambient Air Quality Standards	3.4-6
Table 3.4-5. Project Consistency with Applicable Plan Policies	3.4-10
Table 3.4-6. Imperial County Air Pollution Control District Significance Thresholds – Pounds per Day	3.4-12
Table 3.4-7. Project Construction-Generated Emissions – Unmitigated	3.4-15
Table 3.4-8. Project Construction-Generated Emissions – Mitigated	3.4-15
Table 3.4-9. Project Operational Emissions	3.4-16
Table 3.4-10. Proposed Project Displaced Criteria Pollutant Emissions (Tons)	3.4-17
Table 3.5-1. Vegetation Communities or Land Cover Types within the BSA	3.5-2
Table 3.5-2. Aquatic Resources and Associated Vegetation on the Project Site	3.5-21
Table 3.5-3. Project Consistency with General Plan Goals and Policies	3.5-33
Table 3.6-1. Previously Recorded Cultural Resources Within 1-Mile of the Project Area	3.6-5
Table 3.6-2. Updated and Newly Recorded Resources within the Project Area	3.6-6=7
Table 3.6-3. Project Consistency with Applicable General Plan Goals and Objectives	3.6-14
Table 3.7-1. Faults with a Risk Contribution of Greater than One Percent	3.7-5
Table 3.7-2. Project Consistency with Applicable General Plan Policies	3.7-11
Table 3.8-1. California Greenhouse Gas Emissions Inventory 2000 to 2018	3.8-3
Table 3.8-2. Project Construction-Related Greenhouse Gas Emissions	3.8-11
Table 3.8-3. Project Operation-Related Greenhouse Gas Emissions	3.8-12
Table 3.8-4. Proposed Project Displaced GHG Emissions (Metric Tons)	3.8-13
Table 3.10-1. Beneficial Uses of Receiving Waters	3.10-5
Table 3.10-2. Project Consistency with Applicable General Plan Policies	3.10-7
Table 3.10-3. Source Control Best Management Practices	3.10-12
Table 3.11-1. Project Consistency with Applicable General Plan Policies	3.11-5
Table 3.12-1. Existing (Baseline) Noise Measurements	3.12-4
Table 3.12-2. Human Reaction and Damage to Buildings for Continuous or Frequent Intermittent Vibration Levels	3.12-7
Table 3.12-3. Representative Vibration Source Levels for Construction Equipment	3.12-7
Table 3.12-4. Land Use Compatibility for Community Noise Environments	3.12-9
Table 3.12-5. Project Consistency with Applicable General Plan Noise Policies	3.12-11
Table 3.12-6. Imperial County Exterior Noise Standards	3.12-13
Table 3.12-7. Construction Average Noise Levels (dBA) at the Nearest Receptor	3.12-15

Table 3.12-8. Modeled Operational Noise Levels at Nearest Sensitive Receptor.....	3.12-17
Table 3.12-9. Project Construction Vibration Levels at 100 Feet	3.12-18
Table 3.13-1. HCM Level of Service Thresholds for Intersections	3.13-5
Table 3.13-2. Caltrans Freeway Segment Level of Service Definitions	3.13-5
Table 3.13-3. Construction Phase Trip Generation	3.13-6
Table 3.14-1. Project Consistency with Applicable General Plan Goals and Objectives	3.14-4
Table 5-1. Projects Considered in the Cumulative Impact Analysis	5-3
Table 6-1. Electricity Consumption in Imperial County 2015–2019	6-2
Table 6-2. Natural Gas Consumption in Imperial County 2015–2019	6-2
Table 6-3. Automotive Fuel Consumption in Imperial County 2016–2020	6-2
Table 6-4. Proposed Project Energy and Fuel Consumption	6-3
Table 7-1. Comparison of Alternative Impacts to Proposed Project.....	7-11



Figures

Figure 2-1. Regional Location	2-2
Figure 2-2. Project Site	2-3
Figure 2-3. Site Plan	2-5
Figure 2-4. Construction Worker Access	2-11
Figure 2-5. Bridge Crossing – Pedestrian Access Only.....	2-12
Figure 2-6. Proposed Heavy Construction Equipment Access.....	2-13
Figure 2-7. Proposed Bridge Crossings over All-American Canal.....	2-15
Figure 3.5 1. Vegetation Communities and Land Cover Types in the BSA (Sheet 1 of 9).....	3.5-3
Figure 3.5 2. Vegetation Communities and Land Cover Types in the BSA (Sheet 2 of 9).....	3.5-4
Figure 3.5 3. Vegetation Communities and Land Cover Types in the BSA (Sheet 3 of 9).....	3.5-5
Figure 3.5 4. Vegetation Communities and Land Cover Types in the BSA (Sheet 4 of 9).....	3.5-6
Figure 3.5 5. Vegetation Communities and Land Cover Types in the BSA (Sheet 5 of 9).....	3.5-7
Figure 3.5 6. Vegetation Communities and Land Cover Types in the BSA (Sheet 6 of 9).....	3.5-8
Figure 3.5 7. Vegetation Communities and Land Cover Types in the BSA (Sheet 7 of 9).....	3.5-9
Figure 3.5 8. Vegetation Communities and Land Cover Types in the BSA (Sheet 8 of 9).....	3.5-10
Figure 3.5 9. Vegetation Communities and Land Cover Types in the BSA (Sheet 9 of 9).....	3.5-11
Figure 3.5 10. Special-Status Species Observed On Site (Sheet 1 of 2).....	3.5-15
Figure 3.5 11. Special-Status Species Observed On Site (Sheet 2 of 2).....	3.5-16
Figure 3.5 12. Potential Jurisdictional Waters (Sheet 1 of 6).....	3.5-23
Figure 3.5 13. Potential Jurisdictional Waters (Sheet 2 of 6).....	3.5-24
Figure 3.5 14. Potential Jurisdictional Waters (Sheet 3 of 6).....	3.5-25
Figure 3.5 15. Potential Jurisdictional Waters (Sheet 4 of 6).....	3.5-26
Figure 3.5 16. Potential Jurisdictional Waters (Sheet 5 of 6).....	3.5-27
Figure 3.5 17. Potential Jurisdictional Waters (Sheet 6 of 6).....	3.5-28
Figure 3.7-1. Soils Mapped on the Project Site	3.7-3
Figure 3.7-2. Regional Fault Map	3.7-7
Figure 3.11-1. General Plan Land Use Designations	3.11-2
Figure 3.11-2. Zoning Designations	3.11-3
Figure 3.12-1. Common Noise Levels	3.12-2
Figure 3.12-2. Noise Measurement Locations	3.12-5
Figure 3.13-1. Proposed Heavy Construction Equipment Access.....	3.13-11
Figure 3.13-2. Proposed Bridge Crossings over All-American Canal.....	3.13-13
Figure 5-1. Cumulative Projects.....	5-4

This page is intentionally blank.



Appendices

Appendix A	Initial Study and Notice of Preparation and Comment Letters
Appendix B	Visual Impact Assessment Letter Report
Appendix C	Air Quality and Greenhouse Gas Assessment
Appendix D	Biological Resources Technical Report (BRTR)
Appendix E	Aquatic Resources Delineation Report
Appendix F	Cultural Resources Inventory
Appendix G	Preliminary Geological and Geotechnical Hazard Evaluation Report
Appendix H	Phase I Environmental Site Assessment
Appendix I	Drainage Plan
Appendix J	Noise Impact Assessment
Appendix K	Traffic Impact Study
Appendix L	Water Supply Assessment
Appendix M	Energy Impact Assessment

This page is intentionally blank.

0.1 Introduction and Summary

This Final Environmental Impact Report (EIR) has been prepared in accordance with the California Environmental Quality Act (CEQA) as amended (Public Resources Code Section 21000 et seq.), and CEQA Guidelines (California Administrative Code Section 15000 et seq.).

According to CEQA Guidelines §15132, the Final EIR shall consist of the following:

- a. The Draft EIR or a revision of the Draft;
- b. Comments and recommendations received on the Draft EIR, either verbatim or in summary;
- c. A list of persons, organizations, and public agencies commenting on the Draft EIR;
- d. The responses of the Lead Agency to significant environmental points raised in the review and consultation process; and
- e. Any other information added by the Lead Agency.

In accordance with these requirements, the VEGA SES 4 Solar Energy Project Final EIR is comprised of the following:

- Draft EIR, November 2022 (SCH No. 2021050018); and
- This Final EIR document, dated February 2023, that incorporates the information required by §15132.

Format of the Final EIR

Section 0.1 Introduction

This section describes CEQA requirements and content of this Final EIR.

Section 0.2 Responses to Comment Letters Received on the Draft EIR

This section provides copies of the comment letters received and individual responses to written comments. In accordance with Public Resources Code 21092.5, copies of the written proposed responses to public agencies will be forwarded to the agencies at least 10 days prior to certifying the EIR. The responses conform to CEQA Guideline 15088, providing "... good faith, reasoned analysis in response."

Section 0.3 Errata to the Draft EIR

This section of the Final Environmental Impact Report (EIR) identifies the location of, or contains revisions to, information included in the Draft EIR dated November 2022, based upon additional or revised information required to prepare a response to a specific comment. The information added to the EIR does not meet the requirements for recirculation pursuant to Section 15088.5 of the State *California Environmental Quality Act (CEQA) Guidelines*.

Section 0.4 Mitigation Monitoring and Reporting Program

This section includes the Mitigation Monitoring and Reporting Program (MMRP) which identifies the mitigation measures, timing, and responsibility for implementation of the measures.

0.2 Response to Comments

This section contains responses to all comment letters received on the Draft Environmental Impact Report (DEIR). One letter was received during the comment period, which began on November 22, 2022 and closed on January 10, 2023. A copy of the letter with bracketed comment numbers on the right margin is followed by the response for each comment as indexed in the letter. The comment letter is listed in Table 0.2-1.

Table 0.2-1. VEGA SES 4 Solar Energy Project Draft EIR Comment Letters

Letter	Commenter	Date
A	California Department of Transportation	January 25, 2022

CALIFORNIA STATE TRANSPORTATION AGENCY

GAVIN NEWSOM, GOVERNOR

California Department of Transportation

DISTRICT 11
4050 TAYLOR STREET, MS-240
SAN DIEGO, CA 92110
(619) 709-5152 | FAX (619) 688-4299 TTY 711
www.dot.ca.gov



January 25, 2023

11-IMP-98
PM 42.8
VEGA SES 4 Solar Energy Project
SCH 2021050018

Mr. David Black
County of Imperial
Planning and Development Services
801 Main St.
El Centro, CA 92243

Dear Mr. Black:

Thank you for including the California Department of Transportation (Caltrans) in the review process for the proposed VEGA SES 4 Solar Energy project near State Route 98 (SR-98). The mission of Caltrans is to provide a safe and reliable transportation network that serves all people and respects the environment. The Local Development Review (LDR) Program reviews land use projects and plans to ensure consistency with our mission and state planning priorities.

Safety is one of Caltrans' strategic goals. Caltrans strives to make the year 2050 the first year without a single death or serious injury on California's roads. We are striving for more equitable outcomes for the transportation network's diverse users. To achieve these ambitious goals, we will pursue meaningful collaboration with our partners. We encourage the implementation of new technologies, innovations, and best practices that will enhance the safety on the transportation network. These pursuits are both ambitious and urgent, and their accomplishment involves a focused departure from the status quo as we continue to institutionalize safety in all our work.

A.1

"Provide a safe and reliable transportation network that serves all people and respects the environment"

Mr. David Black
January 25, 2023
Page 2

Caltrans has the following comments:

Traffic Analysis

The proposed project access at SR-98 post mile 45.23, will have construction vehicles using SR-98 and driving on the shoulder then onto an unpaved road, to access the project site.

- SR-98 Shoulder is not designed for this and therefore Caltrans paving and Materials branch will need to review and approve any proposed project site access, from SR-98.
- Soil tracking onto SR-98 will need to be mitigated through the Caltrans encroachment permit process.
- A traffic control plan will need to be approved to inform the public motorists of construction equipment entering and exiting a non-paved road.
- For safety purposes, acceleration and/or deceleration lanes may be required as part of the permitted access design, from SR-98.

A.2

The I-8 and Gordon Wells Road access path may need soil tracking mitigation at Gordon Wells Road to prevent soil tracked onto the I-8 ramps. Possible coordination with Caltrans Permits Branch will be required.

A.3

Please follow Caltrans encroachment permits manual's appendix J "Road Connections and Driveways" and the most current version of Caltrans Highway Design Manual (HDM) Section 205.4.

- Driveways connecting to State highways shall be paved a minimum of 20 feet from the edge of shoulder or to the edge of State right of way, whichever is less to minimize or eliminate tracking onto SR-98.

A.4

Hydrology

Caltrans generally does not allow development projects to impact hydraulics within the State's Right-of-Way. Any modification to the existing Caltrans drainage and/or increase in runoff to State facilities will not be allowed.

A.5

Right-of-Way

Per Business and Profession Code 8771, perpetuation of survey monuments by a licensed land surveyor is required, if they are being destroyed by any construction.

A.6

Clearly show/delineate Caltrans easements and Caltrans Right-of-Way (R/W) on future project plans.

"Provide a safe and reliable transportation network that serves all people and respects the environment"



Mr. David Black
January 25, 2023
Page 3

Any work performed within Caltrans' Right of Way (R/W) will require discretionary review and approval by Caltrans. As part of the encroachment permit process, the applicant must provide an approved final environmental document, corresponding technical studies, and necessary regulatory and resource agency permits, specifically, any CEQA determinations or exemptions.

A.6
cont'd

If you have any questions or concerns, please contact Roger Sanchez, LDR Coordinator, at (619) 987-1043 or by e-mail sent to roger.sanchez-rangel@dot.ca.gov.

A.7

Sincerely,

Maurice A. Eaton

MAURICE EATON
Branch Chief
Local Development Review

"Provide a safe and reliable transportation network that serves all people and respects the environment"

Letter A

California Department of Transportation January 25, 2023

- A.1** This is an introductory comment that provides a general summary of the project and states the mission of the California Department of Transportation (Caltrans). This comment does not raise a specific issue related to the adequacy of the Draft EIR; therefore, no further response is required, and the comment is noted for the record.
- A.2** This comment states that construction vehicles will access the project site using State Route 98. For clarification, as stated on Draft EIR page 2-9, workers would utilize an existing driveway off State Route 98 while vendors and heavy construction equipment would exit south from Interstate 8 onto Gordon Wells Road. As a condition of project approval, the Applicant will be required to coordinate with Caltrans with respect to project site access from Caltrans facilities and right of way, including State Route 98 and I-8. It is acknowledged that an encroachment permit may be required for either of these Caltrans facilities for site access. Soil tracking mitigation, preparation and approval of a traffic control plan, and acceleration/deceleration lane requirements are anticipated to be addressed as part of coordination with Caltrans and the encroachment permit process, as applicable.
- A.3** The County acknowledges that the I-8 and Gordon Wells Road access path may require soil tracking mitigation at Gordon Wells Road to prevent soil tracked onto the I-8 Ramps. The County acknowledges that possible coordination with Caltrans Permit Branch will be required. Please also refer to response to comment A.2.
- A.4** The County acknowledges Caltrans' requirements related to driveways connecting to State Highways as summarized in this comment. As a condition of approval of the project, the Applicant will be required to coordinate with Caltrans with regards to paving requirements for the project's driveway connecting to a State Highway to minimize or eliminate tracking onto State Route 98 and I-8. County conditions of approval will require that the Applicant obtain encroachment permits from Caltrans, as applicable, for site access.
- A.5** This comment addresses drainage and runoff on Caltrans facilities. The project will not impact any Caltrans drainage facilities nor will it increase any runoff to Caltrans facilities.
- A.6** No work within Caltrans right of way is proposed associated with the proposed project. However, the County does acknowledge that any work performed by the Applicant within Caltrans right of way requires approval of an encroachment permit. Please refer to responses to comment A.2 and A.3.
- A.7** The contact information for Caltrans is received and acknowledged.

0.3 Errata to the Draft EIR

A. Introduction

This section of the Final Environmental Impact Report (EIR) identifies the location of, or contains revisions to, information included in the Draft EIR dated November 2022, based upon additional or revised information. The information added to the EIR does not meet the requirements for recirculation pursuant to Section 15088.5 of the State *California Environmental Quality Act (CEQA) Guidelines*.

The new information simply clarifies information presented in the Draft EIR. Text that has been added to the document appears in an underline format. Text that has been deleted appears with strikethrough.

This Errata, in conjunction with the Final EIR, will be used by the County of Imperial in its evaluation and analysis of the proposed project and in the adoption of any findings required by law. Substantial evidence in support of findings may be found anywhere in the administrative record. (14CCR 15091(b)(e)). The County of Imperial is designated the Lead Agency for California Environmental Quality Act (CEQA) compliance.

B. Corrections and Additions

Section 1 Introduction

Page 1-6:

Availability of Reports

~~This~~ The Draft EIR ~~has been~~ was distributed to various federal, state, regional, local agencies and interested parties for a 45-day public review period, from November 22, 2022, through January 10, 2023, in accordance with Section 15087 of the CEQA Guidelines. ~~This~~ The Draft EIR and documents incorporated by reference ~~are~~ were made available for public review at the County of Imperial Planning and Development Services Department, 801 Main Street, El Centro, California 92243. Documents ~~may be reviewed~~ were available for review during regular business hours.

Comments received during the public review period of the Draft EIR ~~will be~~ have been reviewed and responded to in ~~the~~ this Final EIR. The Final EIR ~~will then~~ be reviewed by the Imperial County Planning Commission and Board of Supervisors as a part of the procedure to ~~adopt~~ certify the Final EIR. Additional information on this process may be obtained by contacting the County of Imperial Planning and Development Services Department at (442) 265-1736.

Page 1-9:

Document Organization

The structure of the ~~Draft~~ Final EIR is identified below. The ~~Draft~~ Final EIR is organized into ~~44~~ 14 chapters, including the Executive Summary.

- **Chapter 0.1 Introduction and Summary** describes the CEQA requirements and content of the Final EIR.

- **Chapter 0.2 Responses to Comment Letters Received on the Draft EIR** provides copies of the comment letters received and individual responses to written comments.
- **Chapter 0.3 Errata to the Draft EIR** identifies the location of, or contains revisions to, information included in the Draft EIR dated November 2022, based upon additional or revised information required to prepare a response to a specific comment.
- **Chapter 0.4 Mitigation Monitoring and Reporting Program** identifies the mitigation measures, timing, and responsibility for implementation of the measures.

Section 2 Project Description

Page 2-16:

Operation of the proposed project would require upgrades including but not limited to relay upgrades, Phasor Measurement Unit Requirements, Relay, SCADA, Metering and Telecom upgrades at the Ramon Substation located at 75800 Ramon Road, Thousand Palms, CA. The construction and operation of these upgrades by IID required to adequately operate the project are included as part of the project and project analysis.

Section 3.10 Hydrology/Water Quality

Page 3.10-15:

The project site would remain largely impervious over the operational life of the project. The proposed project would result in less than significant impacts associated with the alteration of drainage patterns resulting in substantial erosion or siltation on- or off-site. This is considered a less than significant impact.

C. California Environmental Quality Act Requirements and Findings Supporting Decision Not to Recirculate

CEQA Section 15088.5(e) requires that an EIR which has been made available for public review, but not yet certified, be recirculated whenever significant new information has been added to the EIR. The entire document need not be recirculated, if revisions are limited to specific portions of the document. The recirculated portions of document must be sent to responsible and trustee agencies for consultation and fresh public notice must be given in the manner provided for a draft EIR. However, new information is not presumed to be significant simply because it is new. Indeed, pursuant to State CEQA Guidelines Section 15088.5:

New information added to an EIR is not "significant" unless the EIR is changed in a way that deprives the public of a meaningful opportunity to comment upon a substantial adverse environmental effect of the project or a feasible way to mitigate or avoid such an effect . . . that the project's proponents have declined to implement. State CEQA Guidelines, § 15088.5(a):

In order to be "significant," the new information requiring recirculation includes, for example, a disclosure showing that:

- (1) A new significant environmental impact would result from the project or from a new mitigation measure proposed to be implemented.

(2) A substantial increase in the severity of an environmental impact would result unless mitigation measures are adopted that reduce the impact to a level of insignificance.

(3) A feasible project alternative or mitigation measure considerably different from other previously analyzed would clearly lessen the environmental impacts of the project, but the project's proponent decline to adopt it.

(4) The draft EIR was so fundamentally and basically inadequate and conclusory in nature that meaningful public review and comment were precluded. (State CEQA Guidelines, §15088.5(a)(1)-(4); *Laurel Heights II*, 6 Cal.4th at 1120.)

It is common, and in most cases necessary, to amplify and elaborate on the analysis of an EIR. CEQA anticipates this and such amplification does not constitute significant new "information" unless it triggers one of the four categories described in State CEQA Guidelines Section 15088.5(a). State CEQA Guidelines Section 15088.5(b) provides that "recirculation is not required where the new information added to the EIR merely clarifies or amplifies or makes insignificant modifications in an adequate EIR."

Based upon review of the minor corrections and additions identified in Section B above, the minor corrections and additions do not result in any new or substantially increased significant impacts. Therefore, the County has concluded that recirculation of the Draft EIR is not required.

This page is intentionally blank.

0.4 Mitigation Monitoring and Reporting Program

The County of Imperial will adopt this Mitigation Monitoring and Reporting Program (MMRP) in accordance with Public Resources Code (PRC) Section 21081.6 and Section 15097 of the California Environmental Quality Act (CEQA) Guidelines. The purpose of the MMRP is to ensure that the VEGA SES 4 Solar Energy Project, which is the subject of the Environmental Impact Report (EIR), complies with all applicable environmental mitigation requirements. The mitigation measures for the project will be adopted by the County of Imperial, in conjunction with the certification of the Final EIR. The mitigation measures have been integrated into this MMRP.

The mitigation measures are provided in Table 0.4-1. The specific mitigation measures are identified, as well as the monitoring method, responsible monitoring party, monitoring phase, verification/approval party, date mitigation measure verified or implemented, location of documents (monitoring record), and completion requirement for each mitigation measure.

The mitigation measures applicable to the project include avoiding certain impacts altogether, minimizing impacts by limiting the degree or magnitude of the action and its implementation, and/or reducing or eliminating impacts over time by maintenance operations during the life of the action.

Public Resources Code Section 21081.6 requires the Lead Agency, for each project that is subject to CEQA, to monitor performance of the mitigation measures included in any environmental document to ensure that implementation does, in fact, take place. The County of Imperial is the designated CEQA lead agency for the Mitigation Monitoring and Reporting Program. The County of Imperial is responsible for review of all monitoring reports, enforcement actions, and document disposition as it relates to impacts within the County's jurisdiction. The County of Imperial will rely on information provided by the monitor as accurate and up to date and will field check mitigation measure status as required.

A record of the MMRP will be maintained at County of Imperial, Department of Planning and Development Services, 801 Main Street, El Centro, CA 92243. All mitigation measures contained in the EIR shall be made conditions of the project as may be further described below.

This page is intentionally blank.

Table 0.4-1. Mitigation Measures

MM No.	Mitigation Measure	Monitoring Method	Responsible Monitoring Party	Monitoring Phase	Verification/Approval Party	Date Mitigation Measure Verified or Implemented	Location of Documents (Monitoring Record)	Completion Requirement
Agricultural Resources								
AG-1	<p>Pest Management Plan. Prior to the issuance of a grading permit or building permit (whichever occurs first), a Pest Management Plan shall be developed by the project applicant and approved by the County of Imperial Agricultural Commissioner. The project applicant shall maintain a Pest Management Plan until reclamation is complete. The plan shall provide the following:</p> <ol style="list-style-type: none"> 1. Monitoring, preventative, and management strategies for weed and pest control during construction activities at any portion of the project (e.g., transmission line); 2. Control and management of weeds and pests in areas temporarily disturbed during construction where native seed will aid in site revegetation as follows: <ul style="list-style-type: none"> • Monitor for all pests including insects, vertebrates, weeds, and pathogens. Promptly control or eradicate pests when found, or when notified by the Agricultural Commissioner’s office that a pest problem is present on the project site. The assistance of a licensed pest control advisor is recommended. All treatments must be performed by a qualified applicator or a licensed pest control business; • All treatments must be performed by a qualified applicator or a licensed pest control operator; • “Control” means to reduce the population of common pests below economically damaging levels, and includes attempts to exclude pests before infestation, and effective control methods after infestation. Effective control methods may include physical/mechanical removal, bio control, cultural control, or chemical treatments; • Use of “permanent” soil sterilants to control weeds or other pests is prohibited because this would interfere with reclamation; 	The Department of Planning and Development Services shall verify that a Pest Management Plan has been reviewed and approved by the Imperial County Agricultural Commissioner.	Department of Planning and Development Services and Imperial County Agricultural Commissioner	Prior to the issuance of a grading permit or building permit, during construction	Department of Planning and Development Services and Imperial County Agricultural Commissioner			

Table 0.4-1. Mitigation Measures

MM No.	Mitigation Measure	Monitoring Method	Responsible Monitoring Party	Monitoring Phase	Verification/Approval Party	Date Mitigation Measure Verified or Implemented	Location of Documents (Monitoring Record)	Completion Requirement
	<ul style="list-style-type: none"> • Notify the Agricultural Commissioner’s office immediately regarding any suspected exotic/invasive pest species as defined by the California Department of Food Agriculture and the U.S. Department of Agriculture. Request a sample be taken by the Agricultural Commissioner’s Office of a suspected invasive species. Eradication of exotic pests shall be done under the direction of the Agricultural Commissioner’s Office and/or California Department of Food and Agriculture; • Obey all pesticide use laws, regulations, and permit conditions; • Allow access by Agricultural Commissioner staff for routine visual and trap pest surveys, compliance inspections, eradication of exotic pests, and other official duties; • Ensure all project employees that handle pest control issues are appropriately trained and certified, all required records are maintained and made available for inspection, and all required permits and other required legal documents are current; • Maintain records of pests found and treatments or pest management methods used. Records should include the date, location/block, project name (current and previous if changed), and methods used. For pesticides include the chemical(s) used, EPA Registration numbers, application rates, etc. A pesticide use report may be used for this; • Submit a report of monitoring, pest finds, and treatments, or other pest management methods to the Agricultural Commissioner quarterly within 15 days after the end of the previous quarter, and upon request. The report is required even if no pests were found or treatment occurred. It may consist of a copy of all records for the previous quarter, or may be a summary letter/report as long as the original detailed records are available upon request. 							

Table 0.4-1. Mitigation Measures

MM No.	Mitigation Measure	Monitoring Method	Responsible Monitoring Party	Monitoring Phase	Verification/Approval Party	Date Mitigation Measure Verified or Implemented	Location of Documents (Monitoring Record)	Completion Requirement
	3. A long-term strategy for weed and pest control and management during the operation of the proposed projects. Such strategies may include, but are not limited to: <ul style="list-style-type: none"> • Use of specific types of herbicides and pesticides on a scheduled basis. 4. Maintenance and management of project site conditions to reduce the potential for a significant increase in pest-related nuisance conditions on surrounding agricultural lands. 5. The project shall reimburse the Agricultural Commissioner's office for the actual cost of investigations, inspections, or other required non-routine responses to the site that are not funded by other sources.							
Air Quality								
AQ-1	<p>Fugitive Dust Control. During construction activities, the constructor contractor shall employ the following PM₁₀ reducing measures:</p> 1. All unpaved roads associated with construction shall be effectively stabilized of dust emissions using Imperial County Air Pollution Control District-approved chemical stabilizers/suppressant before the commencement of construction, and every 30 days thereafter until the end of all construction activities. Unpaved roads associated with construction include: <ul style="list-style-type: none"> • The driveway entrance off State Route 98; • The project designated 3.5-acre staging/parking area north of the All-American Canal; • The 1.0 mile of dirt road south of the All-American Canal; and • The 20 miles of existing dirt road paralleling the U.S./Mexico Border from Gordon Wells Road to the project site. Monthly application of Imperial County Air Pollution Control District-approved chemical stabilizers/suppressant shall be applied at a rate of 0.1 gallon/square yard of chemical dust suppressant.	Prior to and during construction, the ICAPCD will verify that the project is in compliance with the fugitive dust control measures as identified in Mitigation Measure AQ-1 and Regulation VIII-Fugitive Dust Control Measures.	Department of Planning and Development Services and ICAPCD	Prior to and during construction	Department of Planning and Development Services and ICAPCD			

Table 0.4-1. Mitigation Measures

MM No.	Mitigation Measure	Monitoring Method	Responsible Monitoring Party	Monitoring Phase	Verification/Approval Party	Date Mitigation Measure Verified or Implemented	Location of Documents (Monitoring Record)	Completion Requirement
	<p>2. Prior to any earthmoving activity, the applicant shall submit a construction dust control plan and obtain Imperial County Air Pollution Control District and Imperial County Planning and Development Services Department (ICPDS) approval.</p> <p>3. Pursuant to ICAPCD, all construction sites, regardless of size, must comply with the requirements contained within Regulation VIII – Fugitive Dust Control Measures. Whereas these Regulation VIII measures are mandatory and are not considered project environmental mitigation measures, the ICAPCD CEQA Handbook’s required additional standard and enhanced mitigation measures listed below shall be implemented prior to and during construction. ICAPCD will verify implementation and compliance with these measures as part of the grading permit review/approval process.</p> <p>ICAPCD Standard Measures for Fugitive Dust (PM₁₀) Control</p> <ul style="list-style-type: none"> • All disturbed areas, including bulk material storage, which is not being actively utilized, shall be effectively stabilized and visible emissions shall be limited to no greater than 20 percent opacity for dust emissions by using water, chemical stabilizers, dust suppressants, tarps, or other suitable material, such as vegetative ground cover. • All on-site and offsite unpaved roads will be effectively stabilized and visible emissions shall be limited to no greater than 20 percent opacity for dust emissions by paving, chemical stabilizers, dust suppressants, and/or watering. • All unpaved traffic areas 1 acre or more with 75 or more average vehicle trips per day will be effectively stabilized and visible emissions shall be limited to no greater than 20 percent opacity for dust emissions by paving, chemical stabilizers, dust suppressants, and/or watering. • The transport of bulk materials shall be completely covered unless 6 inches of freeboard space from the top of the container is maintained with no spillage and loss of bulk material. In 							

Table 0.4-1. Mitigation Measures

MM No.	Mitigation Measure	Monitoring Method	Responsible Monitoring Party	Monitoring Phase	Verification/Approval Party	Date Mitigation Measure Verified or Implemented	Location of Documents (Monitoring Record)	Completion Requirement
	<p>addition, the cargo compartment of all haul trucks is to be cleaned and/or washed at delivery site after removal of bulk material.</p> <ul style="list-style-type: none"> • All track-out or carry-out will be cleaned at the end of each workday or immediately when mud or dirt extends a cumulative distance of 50 linear feet or more onto a paved road within an urban area. • Movement of bulk material handling or transfer shall be stabilized prior to handling or at points of transfer with application of sufficient water, chemical stabilizers, or by sheltering or enclosing the operation and transfer line. • The construction of any new unpaved road is prohibited within any area with a population of 500 or more unless the road meets the definition of a temporary unpaved road. Any temporary unpaved road shall be effectively stabilized and visible emissions shall be limited to no greater than 20 percent opacity for dust emission by paving, chemical stabilizers, dust suppressants, and/or watering. <p>ICAPCD “Discretionary” Measures for Fugitive Dust (PM₁₀) Control</p> <ul style="list-style-type: none"> • Water exposed soil only in those areas where active grading and vehicle movement occurs with adequate frequency to control dust. • Replace ground cover in disturbed areas as quickly as possible. • Automatic sprinkler system installed on all soil piles. • Vehicle speed for all construction vehicles shall not exceed 15 miles per hour on any unpaved surface at the construction site. • Develop a trip reduction plan to achieve a 1.5 average vehicle ridership for construction employees. • Implement a shuttle service to and from retail services and food establishments during lunch hours. <p>Standard Mitigation Measures for Construction Combustion Equipment</p>							

Table 0.4-1. Mitigation Measures

MM No.	Mitigation Measure	Monitoring Method	Responsible Monitoring Party	Monitoring Phase	Verification/Approval Party	Date Mitigation Measure Verified or Implemented	Location of Documents (Monitoring Record)	Completion Requirement
	<ul style="list-style-type: none"> • Use of alternative fueled or catalyst equipped diesel construction equipment, including all off-road and portable diesel-powered equipment. • Minimize idling time either by shutting equipment off when not in use or reducing the time of idling to 5 minutes as a maximum. • Limit, to the extent feasible, the hours of operation of heavy-duty equipment and/or the amount of equipment in use. • Replace fossil fueled equipment with electrically driven equivalents (provided they are not run via a portable generator set). <p>Enhanced Mitigation Measures for Construction Equipment</p> <p>To help provide a greater degree of reduction of PM emissions from construction combustion equipment, ICAPCD recommends the following enhanced measures.</p> <ul style="list-style-type: none"> • Curtail construction during periods of high ambient pollutant concentrations; this may include ceasing of construction activity during the peak hour of vehicular traffic on adjacent roadways. • Implement activity management (e.g., rescheduling activities to reduce short-term impacts). 							
AQ-2	<p>Construction Equipment. Construction equipment shall be equipped with an engine designation of EPA Tier 2 or better (Tier 2+). A list of the construction equipment, including all off-road equipment utilized at the project site by make, model, year, horsepower and expected/actual hours of use, and the associated EPA Tier shall be submitted to the County Planning and Development Services Department and ICAPCD prior to the issuance of a grading permit. The equipment list shall be submitted periodically to ICAPCD to perform a NOx analysis. ICAPCD shall utilize this list to calculate air emissions to verify that equipment use does not exceed significance thresholds. The Planning and Development Services Department and ICAPCD shall verify implementation of this measure.</p>	<p>Prior to the issuance of a grading permit, ICAPCD shall verify that construction equipment is equipped with an engine designation of EPA Tier 2 or better.</p> <p>The equipment list shall be submitted periodically to ICAPCD to perform a NOx analysis.</p>	Department of Planning and Development Services and ICAPCD	Prior to the issuance of a grading permit and during construction	Department of Planning and Development Services and ICAPCD			

Table 0.4-1. Mitigation Measures

MM No.	Mitigation Measure	Monitoring Method	Responsible Monitoring Party	Monitoring Phase	Verification/Approval Party	Date Mitigation Measure Verified or Implemented	Location of Documents (Monitoring Record)	Completion Requirement
AQ-3	Dust Suppression. The project applicant shall employ a method of dust suppression (such as water or chemical stabilization) approved by ICAPCD. The project applicant shall apply chemical stabilization as directed by the product manufacturer to control dust between the panels as approved by ICAPCD, and other non-used areas (exceptions will be the paved entrance and parking area, and Fire Department access/emergency entry/exit points as approved by Fire/ Office of Emergency Services [OES] Department).	During construction, the Department of Planning and Development Services shall verify that the project applicant is employing a method of dust suppression approved by ICAPCD.	Department of Planning and Development Services	During construction	Department of Planning and Development Services			
AQ-4	Operational Dust Control Plan. Prior to issuance of a Certificate of Occupancy, the applicant shall submit an operations dust control plan and obtain ICAPCD and ICPDS approval. ICAPCD Rule 301 Operational Fees apply to any project applying for a building permit. At the time that building permits are submitted for the proposed project, the ICAPCD shall review the project to determine if Rule 310 fees are applicable to the project.	Prior to the issuance of a Certificate of Occupancy, the applicant shall submit an operations dust control plan and obtain ICAPCD and ICPDS approval.	Department of Planning and Development Services	Prior to the issuance of a Certificate of Occupancy	Department of Planning and Development Services and ICAPCD			
Biological Resources								
BIO-1	Rare Plant Surveys. Prior to initiating ground disturbance, rare plant surveys shall be conducted within suitable habitat on the project site during the appropriate blooming period for the Abrams' spurge (approximately September through November), Wiggins' croton (approximately March through May), and sand food (approximately April through June). The surveys shall be conducted by a botanist or qualified biologist in accordance with the USFWS Guidelines for Conducting and Reporting Botanical Inventories for Federally Listed, Proposed, and Candidate Plants (USFWS 1996); the CDFW Protocols for Surveying and Evaluating Impacts to Special Status Native Plant Populations and Sensitive Natural Communities (CDFW 2018); and the CNPS Botanical Survey Guidelines (CNPS 2001). If any special-status species are observed during the rare plant surveys, the location of the individual plant or population will be recorded with a submeter GPS device for mapping purposes. If project-related impacts to rare plants on the project site are unavoidable, then consultation with CDFW may be required to develop a mitigation plan or additional	Prior to initiating ground disturbance, the Department of Planning and Development Services shall verify that rare plant surveys have been conducted on the project site.	Department of Planning and Development Services	Prior to construction	Department of Planning and Development Services			

Table 0.4-1. Mitigation Measures

MM No.	Mitigation Measure	Monitoring Method	Responsible Monitoring Party	Monitoring Phase	Verification/Approval Party	Date Mitigation Measure Verified or Implemented	Location of Documents (Monitoring Record)	Completion Requirement
	avoidance and minimization measures. Mitigation measures that may be implemented if the species is observed include establishing a no-disturbance buffer around locations of individuals or a population, salvage or seed collection, and additional monitoring requirements.							
BIO-2	<p>General Impact Avoidance and Minimization Measures. The following measures will be applicable throughout the life of the project:</p> <ul style="list-style-type: none"> To reduce the potential indirect impact on migratory birds, bats and raptors, the project will comply with the APLIC 2012 Guidelines for overhead utilities, as appropriate, to minimize avian collisions with transmission facilities (APLIC 2012). All electrical components on the project site shall be either undergrounded or protected so that there will be no exposure to wildlife and therefore no potential for electrocution. The project proponent shall designate a Project Biologist who shall be responsible for overseeing compliance with protective measures for the biological resources during vegetation clearing and work activities within and adjacent to areas of native habitat. The Project Biologist will be familiar with the local habitats, plants, and wildlife. The Project Biologist will also maintain communications with the Contractor to ensure that issues relating to biological resources are appropriately and lawfully managed and monitor construction. The Project Biologist will monitor activities within construction areas during critical times, such as vegetation removal, the implementation of Best Management Practices (BMP), and installation of security fencing to protect native species. The Project Biologist will ensure that all wildlife and regulatory agency permit requirements, conservation measures, and general avoidance and minimization measures are properly implemented and followed. The boundaries of all areas to be newly disturbed (including solar facility areas, staging areas, access roads, and sites for temporary placement of construction materials and spoils) will be 	The measures as provided in Mitigation Measure BIO-2 shall be implemented throughout the life of the project.	Department of Planning and Development Services	Prior to construction, during construction, and post-construction	Department of Planning and Development Services			

Table 0.4-1. Mitigation Measures

MM No.	Mitigation Measure	Monitoring Method	Responsible Monitoring Party	Monitoring Phase	Verification/Approval Party	Date Mitigation Measure Verified or Implemented	Location of Documents (Monitoring Record)	Completion Requirement
	<p>delineated with stakes and flagging prior to disturbance. All disturbances, vehicles, and equipment will be confined to the flagged areas.</p> <ul style="list-style-type: none"> • No potential wildlife entrapments (e.g., trenches, bores) will be left uncovered overnight. Any uncovered pitfalls will be excavated to 3:1 slopes at the ends to provide wildlife escape ramps. Alternatively, man-made ramps may be installed. Covered pitfalls will be covered completely to prevent access by small mammals or reptiles. • To avoid wildlife entrapment (including birds), all pipes or other construction materials or supplies will be covered or capped in storage or laydown area, and at the end of each work day in construction, quarrying and processing/handling areas. No pipes or tubing of sizes or inside diameters ranging from 1 to 10 inches will be left open either temporarily or permanently. • No anticoagulant rodenticides, such as Warfarin and related compounds (indandiones and hydroxycoumarins), may be used within the project site, on off-site project facilities and activities, or in support of any other project activities. • Avoid wildlife attractants. All trash and food-related waste shall be placed in self-closing containers and removed regularly from the site to prevent overflow. Workers shall not feed wildlife. Water applied to dirt roads and construction areas for dust abatement shall use the minimal amount needed to meet safety and air quality standards to prevent the formation of puddles, which could attract wildlife. Pooled rainwater or floodwater within retention basins will be removed to avoid attracting wildlife to the active work areas. • To minimize the likelihood for vehicle strikes on wildlife, speed limits will not exceed 15 miles per hour when driving on access roads. All vehicles required for O&M must remain on designated access/maintenance roads. • Avoid night-time construction lighting or if nighttime construction cannot be avoided use shielded directional lighting pointed downward and towards the interior of the project site, 							

Table 0.4-1. Mitigation Measures

MM No.	Mitigation Measure	Monitoring Method	Responsible Monitoring Party	Monitoring Phase	Verification/Approval Party	Date Mitigation Measure Verified or Implemented	Location of Documents (Monitoring Record)	Completion Requirement
	<p>thereby avoiding illumination of adjacent natural areas and the night sky.</p> <ul style="list-style-type: none"> • All construction equipment used for the project will be equipped with properly operating and maintained mufflers. • Hazardous materials and equipment stored overnight, including small amounts of fuel to refuel hand-held equipment, will be stored within secondary containment when within 50 feet of open water to the fullest extent practicable. Secondary containment will consist of a ring of sand bags around each piece of stored equipment/structure. A plastic tarp/visqueen lining with no seams shall be placed under the equipment and over the edges of the sandbags, or a plastic hazardous materials secondary containment unit shall be utilized by the Contractor. • The Contractor will be required to conduct vehicle refueling in upland areas where fuel cannot enter waters of the U.S. and in areas that do not have potential to support federally threatened or endangered species. Any fuel containers, repair materials, including creosote-treated wood, and/or stockpiled material that is left on site overnight, will be secured in secondary containment within the work area and staging/assembly area and covered with plastic at the end of each work day. • In the event that no activity is to occur in the work area for the weekend and/or a period of time greater than 48 hours, the Contractor will ensure that all portable fuel containers are removed from the project site. • All equipment will be maintained in accordance with manufacturer's recommendations and requirements. • Equipment and containers will be inspected daily for leaks. Should a leak occur, contaminated soils and surfaces will be cleaned up and disposed of following the guidelines identified in the Stormwater Pollution Prevention Plan or equivalent, Materials Safety Data Sheets, and any specifications required by other permits issued for the project. 							

Table 0.4-1. Mitigation Measures

MM No.	Mitigation Measure	Monitoring Method	Responsible Monitoring Party	Monitoring Phase	Verification/Approval Party	Date Mitigation Measure Verified or Implemented	Location of Documents (Monitoring Record)	Completion Requirement
	<ul style="list-style-type: none"> • The Contractor will utilize off-site maintenance and repair shops as much as possible for maintenance and repair of equipment. • If maintenance of equipment must occur onsite, fuel/oil pans, absorbent pads, or appropriate containment will be used to capture spills/leaks within all areas. Where feasible, maintenance of equipment will occur in upland areas where fuel cannot enter waters of the U.S. and in areas that do not have potential to support federally threatened or endangered species. • Appropriate BMPs will be used by the Contractor to control erosion and sedimentation and to capture debris and contaminants from bridge construction to prevent their deposition in waterways. No sediment or debris will be allowed to enter the creek or other drainages. All debris from construction of the bridge will be contained so that it does not fall into channel. Appropriate BMPs will be used by the Contractor during construction to limit the spread of resuspended sediment and to contain debris. • Erosion and sediment control devices used for the proposed project, including fiber rolls and bonded fiber matrix, will be made from biodegradable materials such as jute, with no plastic mesh, to avoid creating a wildlife entanglement hazard. • Firearms, open fires, and pets would be prohibited at all work locations and access roads. Smoking would be prohibited along the project alignment. • Cross-country vehicle and equipment use outside of approved designated work areas and access roads shall be prohibited to prevent unnecessary ground and vegetation disturbance. • Any injured or dead wildlife encountered during project-related activities shall be reported to the project biologist, biological monitor, CDFW, or a CDFW-approved veterinary facility as soon as possible to report the observation and determine the best course of action. For special-status species, the Project Biologist shall notify the 							

Table 0.4-1. Mitigation Measures

MM No.	Mitigation Measure	Monitoring Method	Responsible Monitoring Party	Monitoring Phase	Verification/Approval Party	Date Mitigation Measure Verified or Implemented	Location of Documents (Monitoring Record)	Completion Requirement
	<p>County, USFWS, and/or CDFW, as appropriate, within 24 hours of the discovery.</p> <ul style="list-style-type: none"> Stockpiling of material will be allowed only within established work areas. Actively manage the spread of noxious weeds The ground beneath all parked equipment and vehicles shall be inspected for wildlife before moving. 							
BIO-3	<p>Worker Environmental Awareness Program. Prior to project construction, a Worker Environmental Awareness Program shall be developed and implemented by a qualified biologist, and shall be available in both English and Spanish. Handouts summarizing potential impacts to special-status biological resources and the potential penalties for impacts to these resources shall be provided to all construction personnel. At a minimum, the education program shall include the following:</p> <ul style="list-style-type: none"> the purpose for resource protection; a description of special-status species including representative photographs and general ecology; occurrences of USACE, RWQCB, and CDFW regulated features in the project survey area; regulatory framework for biological resource protection and consequences if violated; sensitivity of the species to human activities; avoidance and minimization measures designed to reduce the impacts to special-status biological resources; environmentally responsible construction practices; reporting requirements; the protocol to resolve conflicts that may arise at any time during the construction process; and workers sign acknowledgement form indicating that the Environmental Awareness Training and Education Program that has been completed and would be kept on record. 	<p>Prior to construction, the Department of Planning and Development Services shall verify that a Worker Environmental Awareness Program has been implemented by a qualified biologist. The Department of Planning and Development Services shall verify the completion of the Worker Environmental Awareness Program by obtaining signed acknowledgements forms from workers.</p>	<p>Department of Planning and Development Services</p>	<p>Prior to construction</p>	<p>Department of Planning and Development Services</p>			

Table 0.4-1. Mitigation Measures

MM No.	Mitigation Measure	Monitoring Method	Responsible Monitoring Party	Monitoring Phase	Verification/Approval Party	Date Mitigation Measure Verified or Implemented	Location of Documents (Monitoring Record)	Completion Requirement
BIO-4	<p>Burrowing Owl Avoidance and Minimization. Take Avoidance (pre-construction) surveys for burrowing owl shall be completed prior to project construction. Surveys shall be conducted as detailed within Appendix D of the Staff Report on Burrowing Owl Mitigation (California Department of Fish and Game [CDFG] 2012). If burrowing owl is not detected, construction may proceed.</p> <ul style="list-style-type: none"> If burrowing owl is identified during the non-breeding season (September 1 through January 31), then a 50-meter buffer will be established by the biological monitor. Construction within the buffer will be avoided until a qualified biologist determines that burrowing owl is no longer present or until a CDFW-approved exclusion plan has been implemented. The buffer distance may be reduced if noise attenuation buffers such as hay bales are placed between the occupied burrow and construction activities. If burrowing owl is identified during the breeding season (February 1 through August 31), then an appropriate buffer will be established by the biological monitor in accordance with the <i>Staff Report on Burrowing Owl Mitigation</i> (CDFG 2012). Construction within the buffer will be avoided until a qualified biologist determines that burrowing owl is no longer present or until young have fledged. The buffer distance may be reduced in consultation with CDFW if noise attenuation buffers such as hay bales are placed between the occupied burrow and construction activities. 	<p>Prior to construction, the Department of Planning and Development Services shall verify that pre-construction surveys for burrowing owl were conducted. If burrowing owls are present, the measures as listed in Mitigation Measure BIO-4 shall be implemented.</p>	<p>Department of Planning and Development Services</p>	<p>Prior to construction, during construction</p>	<p>Department of Planning and Development Services</p>			
BIO-5	<p>Pre-Construction Nesting Bird Surveys. If construction or other project activities are scheduled to occur during the bird breeding season (typically February 1 through August 31 for raptors and March 15 through August 31 for the majority of migratory bird species), a pre-construction nesting-bird survey shall be conducted by a qualified avian biologist to ensure that active bird nests, including those for the northern harrier, yellow warbler, burrowing owl, and loggerhead strike, will not be disturbed or destroyed. The survey shall be completed no more than three days prior to initial ground disturbance. The nesting-bird survey shall include the project site and adjacent areas where</p>	<p>Prior to construction, the Department of Planning and Development Services shall verify that a pre-construction nesting bird survey was conducted if project activities are scheduled during the bird breeding season (typically February 1 through August 31 for raptors and March 15 through August 31 for the majority of migratory bird species). If nesting birds are present,</p>	<p>Department of Planning and Development Services</p>	<p>Prior to construction, during construction</p>	<p>Department of Planning and Development Services</p>			

Table 0.4-1. Mitigation Measures

MM No.	Mitigation Measure	Monitoring Method	Responsible Monitoring Party	Monitoring Phase	Verification/Approval Party	Date Mitigation Measure Verified or Implemented	Location of Documents (Monitoring Record)	Completion Requirement
	project activities have the potential to affect active nests, either directly or indirectly due to construction activity or noise. If an active nest is identified, the biologist shall establish an appropriately sized disturbance-limit buffer around the nest using flagging or staking. Construction activities shall not occur within any disturbance-limit buffer zones until the nest is deemed inactive by the qualified biologist. If construction activities cease for a period of greater than three days during the bird breeding season, a pre-construction nesting bird survey shall be conducted prior to the commencement of activities. Final construction buffers or setback distances shall be determined by the qualified biologist in coordination with USFWS and CDFW on a case-by-case basis, depending on the species, season in which disturbance shall occur, the type of disturbance, and other factors that could influence susceptibility to disturbance (e.g., topography, vegetation, existing disturbance levels, etc.).	the measures as listed in Mitigation Measure BIO-5 shall be implemented.						
BIO-6	Pre-Construction Survey for Special-Status Species. A pre-construction survey shall be conducted for special-status wildlife species within all areas of potential permanent and temporary disturbance. The pre-construction survey shall take place no more than 14 days prior to the start of ground-disturbing activities. The pre-construction surveys should take place regardless of breeding season timing and shall focus on identifying the presence of special-status wildlife species present on the project site or that were identified as having a high potential to occur on the site. These species include, but are not limited to, flat-tailed horned lizard, burrowing owl, northern harrier, and yellow warbler. Should any special-status species be identified during the pre-construction survey, consultation to develop suitable avoidance and minimization measures with the appropriate agency (USFWS, CDFW) may need to be undertaken.	Prior to construction, the Department of Planning and Development Services shall verify that a pre-construction survey for special-status species was conducted.	Department of Planning and Development Services	Prior to construction	Department of Planning and Development Services			
BIO-7	Bat Acoustic Surveys and Monitoring. To avoid impacts to bat species, a qualified bat biologist shall conduct an appropriate combination of sampling, exit counts, and acoustic surveys to determine if bats are using the palm tree resources in the project area. If project-related impacts to bat species are unavoidable, additional measures may need to be	Prior to construction, the Department of Planning and Development Services shall verify that bat acoustic surveys have been conducted.	Department of Planning and Development Services	Prior to construction, during construction	Department of Planning and Development Services			

Table 0.4-1. Mitigation Measures

MM No.	Mitigation Measure	Monitoring Method	Responsible Monitoring Party	Monitoring Phase	Verification/Approval Party	Date Mitigation Measure Verified or Implemented	Location of Documents (Monitoring Record)	Completion Requirement
	implemented to reduce or eliminate impacts to bat species, including maternity roosts, such as tree removal occurring outside of bat breeding season (October through February) or two-step, two-day removal of palm trees under supervision of a qualified bat biologist.							
Cultural Resources								
CR-1	Environmentally Sensitive Area Fencing. Prior to issuance of grading permits and in coordination with a qualified archaeologist to be retained by the project applicant, the construction zone shall be narrowed or otherwise altered to avoid Sites 2020-142-001, 2020-142-002, 2020-142-004, 2020-142-005, and 2020-142-008. The area within 100 feet of Sites 2020-142-001, 2020-142-002, 2020-142-004, 2020-142-005, and 2020-142-008 shall be designated Environmentally Sensitive Area (ESA) and fenced or flagged with exclusion markers to ensure avoidance. Protective fencing shall not identify the protected area as a cultural resource area in order to discourage unauthorized disturbance or collection of artifacts. The ESA fencing or flags shall remain in place throughout project construction.	Prior to issuance of grading permits, the Department of Planning and Development Services shall verify the following: 1. The construction zone was narrowed or otherwise altered to avoid Sites 2020-142-001, 2020-142-002, 2020-142-004, 2020-142-005, and 2020-142-008. 2. The area within 100 feet of Sites 2020-142-001, 2020-142-002, 2020-142-004, 2020-142-005, and 2020-142-008 has been designated Environmentally Sensitive Area (ESA) and fenced or flagged with exclusion markers to ensure avoidance.	Department of Planning and Development Services	Prior to grading	Department of Planning and Development Services			
CR-2	Evaluate Significance of Find (Unknown Cultural Resources). If subsurface deposits believed to be cultural in origin are discovered during construction, all work must halt within a 100-foot radius of the discovery. A qualified professional archaeologist who meets the Secretary of the Interior's Standards for prehistoric and historic archaeology and is familiar with the resources of the region, shall be retained to evaluate the significance of the find, and shall have the authority to modify the no work radius as appropriate, using professional judgment. The following notifications shall apply, depending on the nature of the find:	The Department of Planning and Development Services shall verify that the project applicant has retained a qualified professional archaeologist. If the professional archaeologist determines that the find does represent a cultural resource, work may not resume within the no-work radius until the Imperial County Planning and	Department of Planning and Development Services	During grading and construction	Department of Planning and Development Services			

Table 0.4-1. Mitigation Measures

MM No.	Mitigation Measure	Monitoring Method	Responsible Monitoring Party	Monitoring Phase	Verification/Approval Party	Date Mitigation Measure Verified or Implemented	Location of Documents (Monitoring Record)	Completion Requirement
	<ul style="list-style-type: none"> If the professional archaeologist determines that the find does not represent a cultural resource, work may resume immediately, and no agency notifications are required. If the professional archaeologist determines that the find does represent a cultural resource from any time period or cultural affiliation, he or she shall immediately notify the Imperial County Planning and Development Services Department. The Imperial County Planning and Development Services Department shall consult with the professional archaeologist on a finding of eligibility and implement appropriate treatment measures if the find is determined to be an Historical Resource under CEQA, as defined in Section 15064.5(a) of the CEQA Guidelines, or an Historic Property, as defined in 36 CFR 60.4. Work may not resume within the no-work radius until the Imperial County Planning and Development Services Department, through consultation as appropriate, determine that the site either: 1) is not an Historical Resource under CEQA or an Historic Property under Section 106; or 2) that the treatment measures have been completed to their satisfaction. 	Development Services Department, through consultation as appropriate, determine that the site either: 1) is not an Historical Resource under CEQA or an Historic Property under Section 106; or 2) that the treatment measures have been completed to their satisfaction.						
CR-3	<p>Evaluate Significance of Find (Unknown Archaeological Resources). In the event of the discovery of previously unidentified archaeological materials, the contractor shall immediately cease all work activities within approximately 100 feet of the discovery. After cessation of excavation, the contractor shall immediately contact the Imperial County Department of Planning and Development Services Department. Except in the case of cultural items that fall within the scope of the Native American Grave Protection and Repatriation Act, the discovery of any cultural resource within the project area shall not be grounds for a “stop work” notice or otherwise interfere with the project’s continuation except as set forth in this paragraph.</p> <p>In the event of an unanticipated discovery of archaeological materials during construction, the applicant shall retain the services of a qualified professional archaeologist, meeting the Secretary of</p>	If the qualified archaeologist determines that a discovery constitutes a significant resource under CEQA and it cannot be avoided, the Department of Planning and Development Services shall verify that an archaeological data recovery program has been conducted.	Department of Planning and Development Services	During grading and construction	Department of Planning and Development Services			

Table 0.4-1. Mitigation Measures

MM No.	Mitigation Measure	Monitoring Method	Responsible Monitoring Party	Monitoring Phase	Verification/Approval Party	Date Mitigation Measure Verified or Implemented	Location of Documents (Monitoring Record)	Completion Requirement
	<p>the Interior's Standards for a Qualified Archaeologist, to evaluate the significance of the materials prior to resuming any construction-related activities in the vicinity of the find. If the qualified archaeologist determines that the discovery constitutes a significant resource under CEQA and it cannot be avoided, the applicant shall implement an archaeological data recovery program.</p>							
<p>CR-4</p>	<p>Human Remains. If subsurface deposits believed to be human in origin are discovered during construction, all work must halt within a 100-foot radius of the discovery. A qualified professional archaeologist who meets the Secretary of the Interior's Standards for prehistoric and historic archaeology and is familiar with the resources of the region, shall be retained to evaluate the significance of the find, and shall have the authority to modify the no work radius as appropriate, using professional judgment. The following notifications shall apply, depending on the nature of the find:</p> <ul style="list-style-type: none"> • If the find includes human remains, or remains that are potentially human, the professional archaeologist shall ensure reasonable protection measures are taken to protect the discovery from disturbance (AB 2641). The archaeologist shall notify the Imperial County Coroner (per § 7050.5 of the Health and Safety Code). The provisions of § 7050.5 of the California Health and Safety Code, § 5097.98 of the California PRC, and AB 2641 will be implemented. • If the Coroner determines the remains are Native American and not the result of a crime scene, the Coroner will notify the NAHC, which then will designate a Native American Most Likely Descendant (MLD) for the project (§ 5097.98 of the PRC). The designated MLD will have 48 hours from the time access to the property is granted to make recommendations concerning treatment of the remains. If the landowner does not agree with the recommendations of the MLD, the NAHC may mediate (§ 5097.94 of the PRC). If no agreement is reached, the landowner must rebury the remains where they will not be further disturbed (§ 5097.98 	<p>During grading and construction, discovery of human remains shall result in work stoppage in that area until the coroner and the Native American Heritage Commission are contacted.</p> <p>Work may not resume within the no-work radius until the Imperial County Planning and Development Services Department, through consultation as appropriate, determine that the treatment measures have been completed to their satisfaction.</p>	<p>Department of Planning and Development Services</p>	<p>During grading and construction</p>	<p>Department of Planning and Development Services</p>			

Table 0.4-1. Mitigation Measures

MM No.	Mitigation Measure	Monitoring Method	Responsible Monitoring Party	Monitoring Phase	Verification/Approval Party	Date Mitigation Measure Verified or Implemented	Location of Documents (Monitoring Record)	Completion Requirement
	<p>of the PRC). This will also include either recording the site with the NAHC or the appropriate Information Center; using an open space or conservation zoning designation or easement; or recording a reinterment document with the county in which the property is located (AB 2641). Work may not resume within the no-work radius until the Imperial County Planning and Development Services Department, through consultation as appropriate, determine that the treatment measures have been completed to their satisfaction.</p>							

Table 0.4-1. Mitigation Measures

MM No.	Mitigation Measure	Monitoring Method	Responsible Monitoring Party	Monitoring Phase	Verification/Approval Party	Date Mitigation Measure Verified or Implemented	Location of Documents (Monitoring Record)	Completion Requirement
Geology and Soils								
GEO-1	<p>Prepare Geotechnical Report(s) as Part of Final Engineering for the Project and Implement Required Measures. Facility design for all project components shall comply with the site-specific design recommendations as provided by a licensed geotechnical or civil engineer to be retained by the project applicant. The final geotechnical and/or civil engineering report shall address and make recommendations on the following:</p> <ul style="list-style-type: none"> • Site preparation • Soil bearing capacity • Appropriate sources and types of fill • Potential need for soil amendments • Structural foundations • Grading practices • Soil corrosion of concrete and steel • Erosion/winterization • Seismic ground shaking • Liquefaction • Expansive/unstable soils <p>In addition to the recommendations for the conditions listed above, the geotechnical investigation shall include subsurface testing of soil and groundwater conditions, and shall determine appropriate foundation designs that are consistent with the version of the CBC that is applicable at the time building and grading permits are applied for. All recommendations contained in the final geotechnical engineering report shall be implemented by the project applicant. The final geotechnical and/or civil engineering report shall be submitted to Imperial County Public Works Department, Engineering Division for review and approval prior to issuance of building permits.</p>	<p>Prior to the issuance of a grading permit, the Imperial County Public Works Department, Engineering Division shall review and approve a Final Geotechnical Report and/or Civil Engineering Report.</p>	<p>Department of Planning and Development Services and Imperial County Public Works Department, Engineering Division</p>	<p>Prior to issuance of a grading permit</p>	<p>Department of Planning and Development Services and Imperial County Public Works Department, Engineering Division</p>			

Table 0.4-1. Mitigation Measures

MM No.	Mitigation Measure	Monitoring Method	Responsible Monitoring Party	Monitoring Phase	Verification/Approval Party	Date Mitigation Measure Verified or Implemented	Location of Documents (Monitoring Record)	Completion Requirement
GEO-2	Paleontological Resources. In the event that unanticipated paleontological resources or unique geologic resources are encountered during ground-disturbing activities, work must cease within 50 feet of the discovery and a paleontologist shall be hired to assess the scientific significance of the find. The consulting paleontologist shall have knowledge of local paleontology and the minimum levels of experience and expertise as defined by the <i>Society of Vertebrate Paleontology's Standard Procedures (2010) for the Assessment and Mitigation of Adverse Impacts to Paleontological Resources</i> . If any paleontological resources or unique geologic features are found within the project site, the consulting paleontologist shall prepare a paleontological Treatment and Monitoring Plan to include the methods that will be used to protect paleontological resources that may exist within the project site, as well as procedures for monitoring, fossil preparation and identification, curation of specimens into an accredited repository, and preparation of a report at the conclusion of the monitoring program.	<p>During grading and construction, discovery of paleontological resources shall result in work stoppage in that area until the Qualified Paleontologist can determine the significance of the find.</p> <p>If any paleontological resources or unique geologic features are found within the project site, the project applicant shall submit a copy of a paleontological Treatment and Monitoring Plan.</p> <p>The project applicant shall submit a copy of the Paleontological Resources Monitoring Report to the Department of Planning and Development Services.</p>	Department of Planning and Development Services	During grading and post ground-disturbing activities	Department of Planning and Development Services			
Hydrology/Water Quality								
HYD-1	Prepare SWPPP and Implement BMPs Prior to Construction and Site Restoration. The project applicant or its contractor shall prepare a SWPPP specific to the project and be responsible for securing coverage under SWRCB's NPDES stormwater permit for general construction activity (Order 2009-0009-DWQ). The SWPPP shall identify specific actions and BMPs relating to the prevention of stormwater pollution from project-related construction sources by identifying a practical sequence for site restoration, BMP implementation, contingency measures, responsible parties, and agency contacts. The SWPPP shall reflect localized surface hydrological conditions and shall be reviewed and approved by the appropriate agency prior to commencement of work and shall be made conditions of the contract with the contractor selected to build and decommission the project. The SWPPP shall incorporate control measures in the following categories:	Prior to construction and site restoration, the project applicant or its contractor shall prepare a SWPPP with incorporated control measures as outlined in Mitigation Measure HYD-1; and implement BMPs. Department of Planning and Development Services to verify.	Department of Planning and Development Services	Prior to issuance of a grading permit and site restoration	Department of Planning and Development Services			

Table 0.4-1. Mitigation Measures

MM No.	Mitigation Measure	Monitoring Method	Responsible Monitoring Party	Monitoring Phase	Verification/Approval Party	Date Mitigation Measure Verified or Implemented	Location of Documents (Monitoring Record)	Completion Requirement
	<ul style="list-style-type: none"> • Soil stabilization and erosion control practices (e.g., hydroseeding, erosion control blankets, mulching) • Sediment control practices (e.g., temporary sediment basins, fiber rolls) • Temporary and post-construction on- and off-site runoff controls • Special considerations and BMPs for water crossings and drainages • Monitoring protocols for discharge(s) and receiving waters, with emphasis place on the following water quality objectives: dissolved oxygen, floating material, oil and grease, potential of hydrogen (pH), and turbidity • Waste management, handling, and disposal control practices • Corrective action and spill contingency measures • Agency and responsible party contact information • Training procedures that shall be used to ensure that workers are aware of permit requirements and proper installation methods for BMPs specified in the SWPPP <p>The SWPPP shall be prepared by a Qualified SWPPP Practitioner and/or Qualified SWPPP Developer with BMPs selected to achieve maximum pollutant removal and that represent the best available technology that is economically achievable. Emphasis for BMPs shall be placed on controlling discharges of oxygen-depleting substances, floating material, oil and grease, acidic or caustic substances or compounds, and turbidity. BMPs for soil stabilization and erosion control practices and sediment control practices will also be required. Performance and effectiveness of these BMPs shall be determined either by visual means where applicable (i.e., observation of above-normal sediment release), or by actual water sampling in cases where verification of contaminant reduction or elimination, (inadvertent petroleum release) is required to determine adequacy of the measure.</p>							

Table 0.4-1. Mitigation Measures

MM No.	Mitigation Measure	Monitoring Method	Responsible Monitoring Party	Monitoring Phase	Verification/Approval Party	Date Mitigation Measure Verified or Implemented	Location of Documents (Monitoring Record)	Completion Requirement
HYD-2	<p>Incorporate Post-Construction Runoff BMPs into Project Drainage Plan. The project Drainage Plan shall adhere to the County’s Engineering Guidelines Manual, IID “Draft” Hydrology Manual, or other recognized source with approval by the County Engineer to control and manage the on- and off-site discharge of stormwater to existing drainage systems. Infiltration basins will be integrated into the Drainage Plan to the maximum extent practical. The Drainage Plan shall provide both short- and long-term drainage solutions to ensure the proper sequencing of drainage facilities and management of runoff generated from project impervious surfaces as necessary.</p> <p>The project’s Final Drainage Plan shall adhere to the County’s Engineering Guidelines Manual, IID “Draft” Hydrology Manual, or other recognized source with approval by the County Engineer to control and manage the on- and off-site discharge of stormwater to existing drainage systems. The Final Drainage Plan shall provide both short- and long-term drainage solutions to ensure the proper sequencing of drainage facilities and shall include source control and treatment BMPs to adequately treat collected runoff prior to discharge, as necessary.</p>	<p>Post construction, the applicant shall implement a Drainage Plan in accordance with the County and Imperial Irrigation District guidelines for the project site. Department of Planning and Development Services and IID to confirm.</p>	<p>Department of Planning and Development Services</p>	<p>Post construction</p>	<p>Department of Planning and Development Services and IID</p>			



Executive Summary

This Environmental Impact Report (EIR) has been prepared in compliance with the California Environmental Quality Act (CEQA) Public Resources Code [PRC] Section 21000 et seq., the CEQA Guidelines (Section 15000 et seq.) as promulgated by the California Resources Agency and the Governor’s Office of Planning and Research (OPR). The purpose of this environmental document is to assess the potential environmental effects associated with the VEGA SES 4 Solar Energy Project and to propose mitigation measures, where required, to reduce significant impacts.

Project Overview

The VEGA SES 4 Solar Energy Project is located on approximately 450 acres of privately-owned land in the southernmost portion of Imperial County, California. The project site is between the U.S./Mexico international border and the All-American Canal, on the California side. The project site is proposed on two parcels (Assessor Parcel Numbers 059-300-015 and 059-300-017) that are contiguous with each other.

The proposed project consists of three primary components: 1) solar energy generation equipment and associated facilities including a substation and access roads (herein referred to as “solar energy facility”); 2) battery energy storage system (BESS); and 3) gen-tie line that would connect the proposed on-site substation to the point of interconnection at the existing Imperial Irrigation District’s (IID) 92-kV “P” line.

The proposed project involves the construction of a 100-megawatt (MW) alternating current (AC) photovoltaic (PV) solar energy facility with an integrated 100 MW BESS (not to exceed 200 MW) on approximately 450 acres of land. The project proposes to utilize either thin film or crystalline solar PV technology modules mounted either on fixed frames or horizontal single-axis tracker systems. The project would include electronic/electrical equipment, an on-site substation, access road(s) and fencing. The electrical energy produced by the project would be conducted through the project’s interconnection facilities to the proposed 92 kV generator intertie (gen-tie) line and delivered to the existing IID approved point of interconnection on the 92-kV “P” Line located immediately north of the project site and the All-American Canal.

Purpose of an EIR

The purpose of an EIR is to analyze the potential environmental impacts associated with a project. CEQA (Section 15002) states that the purpose of CEQA is to: (1) inform the public and governmental decision makers of the potential significant environmental impacts of a project; (2) identify the ways that environmental damage can be avoided or significantly reduced; (3) prevent significant avoidable damage to the environment by requiring changes in projects through the use of alternatives or mitigation measures when the governmental agency finds the changes to be feasible; and (4) disclose to the public the reasons why a governmental agency approved the project in the manner the agency chose if significant environmental effects are involved.

Eliminated from Further Review in Notice of Preparation

Based on the Initial Study and Notice of Preparation (IS/NOP) prepared for the proposed project (Appendix A of this EIR), Imperial County (County) determined that environmental effects to Forestry

Resources, Energy, Mineral Resources, Population/Housing, Public Services, Recreation, Utilities (Wastewater, Stormwater, and Solid Waste), and Wildfire would not be potentially significant. Therefore, these impacts are not addressed in this EIR; however, the rationale for eliminating these issues is discussed in Chapter 6.0, Effects Found Not Significant.

Summary of Significant Impacts and Mitigation Measures that Reduce or Avoid the Significant Impacts

Based on the analysis presented in the IS/NOP and the information provided in the comments to the IS/NOP, the following environmental topics are analyzed in this EIR:

- Aesthetics
- Agricultural Resources
- Air Quality
- Biological Resources
- Cultural Resources
- Geology and Soils
- Greenhouse Gas Emissions
- Hazards and Hazardous Materials
- Hydrology/Water Quality
- Land Use Planning
- Noise and Vibration
- Transportation
- Tribal Cultural Resources
- Utilities/Service Systems (Water Supply)

Table ES-1 summarizes existing environmental impacts that were determined to be potentially significant, mitigation measures, and level of significance after mitigation associated with the project.

Areas of Controversy and Issues to be Resolved

Areas of Concern

Section 15123(b)(2) of the CEQA Guidelines requires that an EIR identify areas of controversy as well as issues to be resolved known to the Lead Agency, including issues raised by other agencies and the public. A primary issue associated with this solar farm project, and other solar facility projects that are proposed in the County, is the corresponding land use compatibility and fiscal/economic impacts to the County. Through the environmental review process for this project, other areas of concern and issues to be resolved include impacts on IID drains, project site access for construction workers, construction vehicles and equipment, and operational requirements (e.g., periodic maintenance and emergency response access), and U.S./Mexico border patrol operations.

Detailed analyses of these topics are included within each corresponding section contained within this document.



Table ES-1. Summary of Project Impacts and Proposed Mitigation Measures

Environmental Impact	Significance Before Mitigation	Proposed Mitigation Measures	Significance After Mitigation
Agricultural Resources			
<p>Impact 3.3-3: Involve other changes in the existing environment which, due to their location or nature, could result in conversion of Farmland, to non-agricultural use.</p>	<p>Significant</p>	<p>AG-1 Pest Management Plan. Prior to the issuance of a grading permit or building permit (whichever occurs first), a Pest Management Plan shall be developed by the project applicant and approved by the County of Imperial Agricultural Commissioner. The project applicant shall maintain a Pest Management Plan until reclamation is complete. The plan shall provide the following:</p> <ol style="list-style-type: none"> 1. Monitoring, preventative, and management strategies for weed and pest control during construction activities at any portion of the project (e.g., transmission line); 2. Control and management of weeds and pests in areas temporarily disturbed during construction where native seed will aid in site revegetation as follows: <ul style="list-style-type: none"> • Monitor for all pests including insects, vertebrates, weeds, and pathogens. Promptly control or eradicate pests when found, or when notified by the Agricultural Commissioner’s office that a pest problem is present on the project site. The assistance of a licensed pest control advisor is recommended. All treatments must be performed by a qualified applicator or a licensed pest control business; • All treatments must be performed by a qualified applicator or a licensed pest control operator; • “Control” means to reduce the population of common pests below economically damaging levels, and includes attempts to exclude pests before infestation, and effective control methods after infestation. Effective control methods may include physical/mechanical removal, bio control, cultural control, or chemical treatments; 	<p>Less than Significant</p>

Table ES-1. Summary of Project Impacts and Proposed Mitigation Measures

Environmental Impact	Significance Before Mitigation	Proposed Mitigation Measures	Significance After Mitigation
		<ul style="list-style-type: none"> • Use of “permanent” soil sterilants to control weeds or other pests is prohibited because this would interfere with reclamation; • Notify the Agricultural Commissioner’s office immediately regarding any suspected exotic/invasive pest species as defined by the California Department of Food Agriculture and the U.S. Department of Agriculture. Request a sample be taken by the Agricultural Commissioner’s Office of a suspected invasive species. Eradication of exotic pests shall be done under the direction of the Agricultural Commissioner’s Office and/or California Department of Food and Agriculture; • Obey all pesticide use laws, regulations, and permit conditions; • Allow access by Agricultural Commissioner staff for routine visual and trap pest surveys, compliance inspections, eradication of exotic pests, and other official duties; • Ensure all project employees that handle pest control issues are appropriately trained and certified, all required records are maintained and made available for inspection, and all required permits and other required legal documents are current; • Maintain records of pests found and treatments or pest management methods used. Records should include the date, location/block, project name (current and previous if changed), and methods used. For pesticides include the chemical(s) used, EPA Registration numbers, application rates, etc. A pesticide use report may be used for this; • Submit a report of monitoring, pest finds, and treatments, or other pest management methods to the Agricultural Commissioner quarterly within 15 days after the end of the previous quarter, and upon request. The report is required even if no pests were found or treatment occurred. It may consist of 	



Table ES-1. Summary of Project Impacts and Proposed Mitigation Measures

Environmental Impact	Significance Before Mitigation	Proposed Mitigation Measures	Significance After Mitigation
		<p>a copy of all records for the previous quarter or may be a summary letter/report as long as the original detailed records are available upon request.</p> <ol style="list-style-type: none"> 3. A long-term strategy for weed and pest control and management during the operation of the proposed project. Such strategies may include, but are not limited to: <ul style="list-style-type: none"> • Use of specific types of herbicides and pesticides on a scheduled basis. 4. Maintenance and management of project site conditions to reduce the potential for a significant increase in pest-related nuisance conditions on surrounding agricultural lands. 5. The project shall reimburse the Agricultural Commissioner's office for the actual cost of investigations, inspections, or other required non-routine responses to the site that are not funded by other sources. 	
Air Quality			
<p>Impact 3.4-1: Conflict with or obstruct implementation of the applicable air quality plan.</p>	<p>Less than Significant</p>	<p>AQ-1 Fugitive Dust Control. During construction activities, the constructor contractor shall employ the following PM₁₀ reducing measures:</p> <ol style="list-style-type: none"> 1. All unpaved roads associated with construction shall be effectively stabilized of dust emissions using Imperial County Air Pollution Control District-approved chemical stabilizers/suppressant before the commencement of construction, and every 30 days thereafter until the end of all construction activities. Unpaved roads associated with construction include: <ul style="list-style-type: none"> • The driveway entrance off State Route 98; • The project designated 3.5-acre staging/parking area north of the All-American Canal; • The 1.0 mile of dirt road south of the All-American Canal; and 	<p>Less than Significant</p>

Table ES-1. Summary of Project Impacts and Proposed Mitigation Measures

Environmental Impact	Significance Before Mitigation	Proposed Mitigation Measures	Significance After Mitigation
		<ul style="list-style-type: none"> • The 20 miles of existing dirt road paralleling the U.S./Mexico Border from Gordon Wells Road to the project site. <p>Monthly application of Imperial County Air Pollution Control District-approved chemical stabilizers/suppressant shall be applied at a rate of 0.1 gallon/square yard of chemical dust suppressant.</p> <ol style="list-style-type: none"> 2. Prior to any earthmoving activity, the applicant shall submit a construction dust control plan and obtain Imperial County Air Pollution Control District and Imperial County Planning and Development Services Department (ICPDS) approval. 3. Pursuant to ICAPCD, all construction sites, regardless of size, must comply with the requirements contained within Regulation VIII – Fugitive Dust Control Measures. Whereas these Regulation VIII measures are mandatory and are not considered project environmental mitigation measures, the ICAPCD CEQA Handbook’s required additional standard and enhanced mitigation measures listed below shall be implemented prior to and during construction. ICAPCD will verify implementation and compliance with these measures as part of the grading permit review/approval process. <p>ICAPCD Standard Measures for Fugitive Dust (PM₁₀) Control</p> <ul style="list-style-type: none"> • All disturbed areas, including bulk material storage, which is not being actively utilized, shall be effectively stabilized and visible emissions shall be limited to no greater than 20 percent opacity for dust emissions by using water, chemical stabilizers, dust suppressants, tarps, or other suitable material, such as vegetative groundcover. • All on-site and off-site unpaved roads will be effectively stabilized, and visible emissions shall be limited to no greater than 20 percent opacity for dust emissions by paving, chemical stabilizers, dust suppressants, and/or watering. 	



Table ES-1. Summary of Project Impacts and Proposed Mitigation Measures

Environmental Impact	Significance Before Mitigation	Proposed Mitigation Measures	Significance After Mitigation
		<ul style="list-style-type: none"> • All unpaved traffic areas 1 acre or more with 75 or more average vehicle trips per day will be effectively stabilized and visible emissions shall be limited to no greater than 20 percent opacity for dust emissions by paving, chemical stabilizers, dust suppressants, and/or watering. • The transport of bulk materials shall be completely covered unless 6 inches of freeboard space from the top of the container is maintained with no spillage and loss of bulk material. In addition, the cargo compartment of all haul trucks is to be cleaned and/or washed at delivery site after removal of bulk material. • All track-out or carry-out will be cleaned at the end of each workday or immediately when mud or dirt extends a cumulative distance of 50 linear feet or more onto a paved road within an urban area. • Movement of bulk material handling or transfer shall be stabilized prior to handling or at points of transfer with application of sufficient water, chemical stabilizers, or by sheltering or enclosing the operation and transfer line. • The construction of any new unpaved road is prohibited within any area with a population of 500 or more unless the road meets the definition of a temporary unpaved road. Any temporary unpaved road shall be effectively stabilized, and visible emissions shall be limited to no greater than 20 percent opacity for dust emission by paving, chemical stabilizers, dust suppressants, and/or watering. <p>ICAPCD “Discretionary” Measures for Fugitive Dust (PM₁₀) Control</p>	

Table ES-1. Summary of Project Impacts and Proposed Mitigation Measures

Environmental Impact	Significance Before Mitigation	Proposed Mitigation Measures	Significance After Mitigation
		<ul style="list-style-type: none"> • Water exposed soil only in those areas where active grading and vehicle movement occurs with adequate frequency to control dust. • Replace ground cover in disturbed areas as quickly as possible. • Automatic sprinkler system installed on all soil piles. • Vehicle speed for all construction vehicles shall not exceed 15 miles per hour on any unpaved surface at the construction site. • Develop a trip reduction plan to achieve a 1.5 average vehicle ridership for construction employees. • Implement a shuttle service to and from retail services and food establishments during lunch hours. <p style="text-align: center;">Standard Mitigation Measures for Construction Combustion Equipment</p> <ul style="list-style-type: none"> • Use of alternative fueled or catalyst equipped diesel construction equipment, including all off-road and portable diesel-powered equipment. • Minimize idling time either by shutting equipment off when not in use or reducing the time of idling to 5 minutes as a maximum. • Limit, to the extent feasible, the hours of operation of heavy-duty equipment and/or the amount of equipment in use. • Replace fossil fueled equipment with electrically driven equivalents (provided they are not run via a portable generator set). <p style="text-align: center;">Enhanced Mitigation Measures for Construction Equipment</p>	



Table ES-1. Summary of Project Impacts and Proposed Mitigation Measures

Environmental Impact	Significance Before Mitigation	Proposed Mitigation Measures	Significance After Mitigation
		<p>To help provide a greater degree of reduction of PM emissions from construction combustion equipment, ICAPCD recommends the following enhanced measures.</p> <ul style="list-style-type: none"> • Curtail construction during periods of high ambient pollutant concentrations; this may include ceasing of construction activity during the peak hour of vehicular traffic on adjacent roadways. • Implement activity management (e.g., rescheduling activities to reduce short-term impacts). <p>AQ-2 Construction Equipment. Construction equipment shall be equipped with an engine designation of EPA Tier 2 or better (Tier 2+). A list of the construction equipment, including all off-road equipment utilized at the project site by make, model, year, horsepower and expected/actual hours of use, and the associated EPA Tier shall be submitted to the County Planning and Development Services Department and ICAPCD prior to the issuance of a grading permit. The equipment list shall be submitted periodically to ICAPCD to perform a NO_x analysis. ICAPCD shall utilize this list to calculate air emissions to verify that equipment use does not exceed significance thresholds. The Planning and Development Services Department and ICAPCD shall verify implementation of this measure.</p> <p>AQ-3 Dust Suppression. The project applicant shall employ a method of dust suppression (such as water or chemical stabilization) approved by ICAPCD. The project applicant shall apply chemical stabilization as directed by the product manufacturer to control dust between the panels as approved by ICAPCD, and other non-used areas (exceptions will be the paved entrance and parking area, and Fire Department access/emergency entry/exit points as approved by Fire/Office of Emergency Services [OES] Department).</p> <p>AQ-4 Operational Dust Control Plan. Prior to issuance of a Certificate of Occupancy, the applicant shall submit an operations dust control plan and obtain ICAPCD and ICPDS approval.</p>	

Table ES-1. Summary of Project Impacts and Proposed Mitigation Measures

Environmental Impact	Significance Before Mitigation	Proposed Mitigation Measures	Significance After Mitigation
		ICAPCD Rule 301 Operational Fees apply to any project applying for a building permit. At the time that building permits are submitted for the proposed project, ICAPCD shall review the project to determine if Rule 310 fees are applicable to the project.	
Biological Resources			
Impact 3.5-1: Impact on special-status species	Significant	<p>BIO-1 Rare Plant Surveys. Prior to initiating ground disturbance, rare plant surveys shall be conducted within suitable habitat on the project site during the appropriate blooming period for the Abrams’ spurge (approximately September through November), Wiggins’ croton (approximately March through May), and sand food (approximately April through June). The surveys shall be conducted by a botanist or qualified biologist in accordance with the USFWS Guidelines for Conducting and Reporting Botanical Inventories for Federally Listed, Proposed, and Candidate Plants (USFWS 1996); the CDFW Protocols for Surveying and Evaluating Impacts to Special Status Native Plant Populations and Sensitive Natural Communities (CDFW 2018); and the CNPS Botanical Survey Guidelines (CNPS 2001). If any special-status species are observed during the rare plant surveys, the location of the individual plant or population will be recorded with a submeter GPS device for mapping purposes. If project-related impacts to rare plants on the project site are unavoidable, then consultation with CDFW may be required to develop a mitigation plan or additional avoidance and minimization measures. Mitigation measures that may be implemented if the species is observed include establishing a no-disturbance buffer around locations of individuals or a population, salvage or seed collection, and additional monitoring requirements.</p> <p>BIO-2 General Impact Avoidance and Minimization Measures. The following measures will be applicable throughout the life of the project:</p> <ul style="list-style-type: none"> To reduce the potential indirect impact on migratory birds, bats and raptors, the project will comply with the APLIC 2012 Guidelines for 	Less than Significant



Table ES-1. Summary of Project Impacts and Proposed Mitigation Measures

Environmental Impact	Significance Before Mitigation	Proposed Mitigation Measures	Significance After Mitigation
		<p>overhead utilities, as appropriate, to minimize avian collisions with transmission facilities (APLIC 2012).</p> <ul style="list-style-type: none"> • All electrical components on the project site shall be either undergrounded or protected so that there will be no exposure to wildlife and therefore no potential for electrocution. • The project proponent shall designate a Project Biologist who shall be responsible for overseeing compliance with protective measures for the biological resources during vegetation clearing and work activities within and adjacent to areas of native habitat. The Project Biologist will be familiar with the local habitats, plants, and wildlife. The Project Biologist will also maintain communications with the Contractor to ensure that issues relating to biological resources are appropriately and lawfully managed and monitor construction. The Project Biologist will monitor activities within construction areas during critical times, such as vegetation removal, the implementation of Best Management Practices (BMP), and installation of security fencing to protect native species. The Project Biologist will ensure that all wildlife and regulatory agency permit requirements, conservation measures, and general avoidance and minimization measures are properly implemented and followed. • The boundaries of all areas to be newly disturbed (including solar facility areas, staging areas, access roads, and sites for temporary placement of construction materials and spoils) will be delineated with stakes and flagging prior to disturbance. All disturbances, vehicles, and equipment will be confined to the flagged areas. • No potential wildlife entrapments (e.g., trenches, bores) will be left uncovered overnight. Any uncovered pitfalls will be excavated to 3:1 slopes at the ends to provide wildlife escape ramps. Alternatively, man-made ramps may be installed. Covered pitfalls will be covered completely to prevent access by small mammals or reptiles. 	

Table ES-1. Summary of Project Impacts and Proposed Mitigation Measures

Environmental Impact	Significance Before Mitigation	Proposed Mitigation Measures	Significance After Mitigation
		<ul style="list-style-type: none"> • To avoid wildlife entrapment (including birds), all pipes or other construction materials or supplies will be covered or capped in storage or laydown area, and at the end of each workday in construction, quarrying and processing/handling areas. No pipes or tubing of sizes or inside diameters ranging from 1 to 10 inches will be left open either temporarily or permanently. • No anticoagulant rodenticides, such as Warfarin and related compounds (indandiones and hydroxycoumarins), may be used within the project site, on off-site project facilities and activities, or in support of any other project activities. • Avoid wildlife attractants. All trash and food-related waste shall be placed in self-closing containers and removed regularly from the site to prevent overflow. Workers shall not feed wildlife. Water applied to dirt roads and construction areas for dust abatement shall use the minimal amount needed to meet safety and air quality standards to prevent the formation of puddles, which could attract wildlife. Pooled rainwater or floodwater within retention basins will be removed to avoid attracting wildlife to the active work areas. • To minimize the likelihood for vehicle strikes on wildlife, speed limits will not exceed 15 miles per hour when driving on access roads. All vehicles required for O&M must remain on designated access/maintenance roads. • Avoid night-time construction lighting or if nighttime construction cannot be avoided use shielded directional lighting pointed downward and towards the interior of the project site, thereby avoiding illumination of adjacent natural areas and the night sky. • All construction equipment used for the Project will be equipped with properly operating and maintained mufflers. • Hazardous materials and equipment stored overnight, including small amounts of fuel to refuel hand-held equipment, will be stored 	



Table ES-1. Summary of Project Impacts and Proposed Mitigation Measures

Environmental Impact	Significance Before Mitigation	Proposed Mitigation Measures	Significance After Mitigation
		<p>within secondary containment when within 50 feet of open water to the fullest extent practicable. Secondary containment will consist of a ring of sandbags around each piece of stored equipment/structure. A plastic tarp/Visqueen lining with no seams shall be placed under the equipment and over the edges of the sandbags, or a plastic hazardous materials secondary containment unit shall be utilized by the Contractor.</p> <ul style="list-style-type: none"> • The Contractor will be required to conduct vehicle refueling in upland areas where fuel cannot enter waters of the U.S. and in areas that do not have potential to support federally threatened or endangered species. Any fuel containers, repair materials, including creosote-treated wood, and/or stockpiled material that is left on site overnight, will be secured in secondary containment within the work area and staging/assembly area and covered with plastic at the end of each workday. • In the event that no activity is to occur in the work area for the weekend and/or a period of time greater than 48 hours, the Contractor will ensure that all portable fuel containers are removed from the project site. • All equipment will be maintained in accordance with manufacturer’s recommendations and requirements. • Equipment and containers will be inspected daily for leaks. Should a leak occur, contaminated soils and surfaces will be cleaned up and disposed of following the guidelines identified in the Stormwater Pollution Prevention Plan or equivalent, Materials Safety Data Sheets, and any specifications required by other permits issued for the project. • The Contractor will utilize off-site maintenance and repair shops as much as possible for maintenance and repair of equipment. 	

Table ES-1. Summary of Project Impacts and Proposed Mitigation Measures

Environmental Impact	Significance Before Mitigation	Proposed Mitigation Measures	Significance After Mitigation
		<ul style="list-style-type: none"> • If maintenance of equipment must occur onsite, fuel/oil pans, absorbent pads, or appropriate containment will be used to capture spills/leaks within all areas. Where feasible, maintenance of equipment will occur in upland areas where fuel cannot enter waters of the U.S. and in areas that do not have potential to support federally threatened or endangered species. • Appropriate BMPs will be used by the Contractor to control erosion and sedimentation and to capture debris and contaminants from bridge construction to prevent their deposition in waterways. No sediment or debris will be allowed to enter the creek or other drainages. All debris from construction of the bridge will be contained so that it does not fall into channel. Appropriate BMPs will be used by the Contractor during construction to limit the spread of resuspended sediment and to contain debris. • Erosion and sediment control devices used for the proposed project, including fiber rolls and bonded fiber matrix, will be made from biodegradable materials such as jute, with no plastic mesh, to avoid creating a wildlife entanglement hazard. • Firearms, open fires, and pets would be prohibited at all work locations and access roads. Smoking would be prohibited along the Project alignment. • Cross-country vehicle and equipment use outside of approved designated work areas and access roads shall be prohibited to prevent unnecessary ground and vegetation disturbance. • Any injured or dead wildlife encountered during project-related activities shall be reported to the project biologist, biological monitor, CDFW, or a CDFW-approved veterinary facility as soon as possible to report the observation and determine the best course of action. For special-status species, the Project Biologist shall notify the 	



Table ES-1. Summary of Project Impacts and Proposed Mitigation Measures

Environmental Impact	Significance Before Mitigation	Proposed Mitigation Measures	Significance After Mitigation
		<p>County, USFWS, and/or CDFW, as appropriate, within 24 hours of the discovery.</p> <ul style="list-style-type: none"> • Stockpiling of material will be allowed only within established work areas. • Actively manage the spread of noxious weeds. • The ground beneath all parked equipment and vehicles shall be inspected for wildlife before moving. <p>BIO-3 Worker Environmental Awareness Program. Prior to project construction, a Worker Environmental Awareness Program shall be developed and implemented by a qualified biologist and shall be available in both English and Spanish. Handouts summarizing potential impacts to special-status biological resources and the potential penalties for impacts to these resources shall be provided to all construction personnel. At a minimum, the education program shall include the following:</p> <ul style="list-style-type: none"> • The purpose for resource protection; • A description of special-status species including representative photographs and general ecology; • Occurrences of USACE, RWQCB, and CDFW regulated features in the Project study area; • Regulatory framework for biological resource protection and consequences if violated; • Sensitivity of the species to human activities; • Avoidance and minimization measures designed to reduce the impacts to special-status biological resources; • Environmentally responsible construction practices; • Reporting requirements; 	

Table ES-1. Summary of Project Impacts and Proposed Mitigation Measures

Environmental Impact	Significance Before Mitigation	Proposed Mitigation Measures	Significance After Mitigation
		<ul style="list-style-type: none"> • The protocol to resolve conflicts that may arise at any time during the construction process; and • Workers sign acknowledgement form indicating that the Environmental Awareness Training and Education Program that has been completed and would be kept on record. <p>BIO-4 Burrowing Owl Avoidance and Minimization. Take Avoidance (pre-construction) surveys for burrowing owl shall be completed prior to project construction. Surveys shall be conducted as detailed within Appendix D of the <i>Staff Report on Burrowing Owl Mitigation</i> (California Department of Fish and Game [CDFG] 2012). If burrowing owl is not detected, construction may proceed.</p> <ul style="list-style-type: none"> • If burrowing owl is identified during the non-breeding season (September 1 through January 31), then a 50-meter buffer will be established by the biological monitor. Construction within the buffer will be avoided until a qualified biologist determines that burrowing owl is no longer present or until a CDFW-approved exclusion plan has been implemented. The buffer distance may be reduced if noise attenuation buffers such as hay bales are placed between the occupied burrow and construction activities. • If burrowing owl is identified during the breeding season (February 1 through August 31), then an appropriate buffer will be established by the biological monitor in accordance with the <i>Staff Report on Burrowing Owl Mitigation</i> (CDFG 2012). Construction within the buffer will be avoided until a qualified biologist determines that burrowing owl is no longer present or until young have fledged. The buffer distance may be reduced in consultation with CDFW if noise attenuation buffers such as hay bales are placed between the occupied burrow and construction activities. <p>BIO-5 Pre-Construction Nesting Bird Survey. If construction or other project activities are scheduled to occur during the bird breeding season (typically February 1 through August 31 for raptors and March 15 through</p>	



Table ES-1. Summary of Project Impacts and Proposed Mitigation Measures

Environmental Impact	Significance Before Mitigation	Proposed Mitigation Measures	Significance After Mitigation
		<p>August 31 for the majority of migratory bird species), a pre-construction nesting-bird survey shall be conducted by a qualified avian biologist to ensure that active bird nests, including those for the northern harrier, yellow warbler, burrowing owl, and loggerhead strike, will not be disturbed or destroyed. The survey shall be completed no more than three days prior to initial ground disturbance. The nesting-bird survey shall include the project site and adjacent areas where project activities have the potential to affect active nests, either directly or indirectly due to construction activity or noise. If an active nest is identified, the biologist shall establish an appropriately sized disturbance-limit buffer around the nest using flagging or staking. Construction activities shall not occur within any disturbance-limit buffer zones until the nest is deemed inactive by the qualified biologist. If construction activities cease for a period of greater than three days during the bird breeding season, a pre-construction nesting bird survey shall be conducted prior to the commencement of activities. Final construction buffers or setback distances shall be determined by the qualified biologist in coordination with USFWS and CDFW on a case-by-case basis, depending on the species, season in which disturbance shall occur, the type of disturbance, and other factors that could influence susceptibility to disturbance (topography, vegetation, existing disturbance levels, etc.).</p> <p>BIO-6 Pre-Construction Survey for Special-Status Species. A pre-construction survey shall be conducted for special-status wildlife species within all areas of potential permanent and temporary disturbance. The pre-construction survey shall take place no more than 14 days prior to the start of ground-disturbing activities. The pre-construction surveys should take place regardless of breeding season timing and shall focus on identifying the presence of special-status wildlife species present on the project site or that were identified as having a high potential to occur on the site. These species include, but are not limited to, flat-tailed horned lizard, burrowing owl, norther harrier, and yellow warbler. Should any special-status species be identified during the pre-construction survey, consultation to develop suitable avoidance and minimization</p>	

Table ES-1. Summary of Project Impacts and Proposed Mitigation Measures

Environmental Impact	Significance Before Mitigation	Proposed Mitigation Measures	Significance After Mitigation
		<p>measures with the appropriate agency (USFWS, CDFW) may need to be undertaken.</p> <p>BIO-7 Bat Acoustic Surveys and Monitoring. To avoid impacts to bat species, a qualified bat biologist shall conduct an appropriate combination of sampling, exit counts, and acoustic surveys to determine if bats are using the palm tree resources in the project area. If project-related impacts to bat species are unavoidable, additional measures may need to be implemented to reduce or eliminate impacts to bat species, including maternity roosts, such as tree removal occurring outside of bat breeding season (October through February) or two-step, two-day removal of palm trees under supervision of a qualified bat biologist.</p>	
Cultural Resources			
<p>Impact 3.6-1: Substantial adverse change in the significance of a historical resource.</p>	<p>Significant</p>	<p>CR-1 Environmentally Sensitive Area Fencing. Prior to issuance of grading permits and in coordination with a qualified archaeologist to be retained by the project applicant, the construction zone shall be narrowed or otherwise altered to avoid Sites 2020-142-001, 2020-142-002, 2020-142-004, 2020-142-005, and 2020-142-008. The area within 100 feet of Sites 2020-142-001, 2020-142-002, 2020-142-004, 2020-142-005, and 2020-142-008 shall be designated Environmentally Sensitive Area (ESA) and fenced or flagged with exclusion markers to ensure avoidance. Protective fencing shall not identify the protected area as a cultural resource area in order to discourage unauthorized disturbance or collection of artifacts. The ESA fencing or flags shall remain in place throughout project construction.</p> <p>CR-2 Evaluate Significance of Find (Unknown Cultural Resources). If subsurface deposits believed to be cultural in origin are discovered during construction, all work must halt within a 100-foot radius of the discovery. A qualified professional archaeologist who meets the Secretary of the Interior’s Standards for prehistoric and historic archaeology and is familiar with the resources of the region, shall be retained to evaluate the significance of the find, and shall have the</p>	<p>Less than Significant</p>



Table ES-1. Summary of Project Impacts and Proposed Mitigation Measures

Environmental Impact	Significance Before Mitigation	Proposed Mitigation Measures	Significance After Mitigation
		<p>authority to modify the no work radius as appropriate, using professional judgment. The following notifications shall apply, depending on the nature of the find:</p> <ul style="list-style-type: none"> • If the professional archaeologist determines that the find does not represent a cultural resource, work may resume immediately, and no agency notifications are required. • If the professional archaeologist determines that the find does represent a cultural resource from any time period or cultural affiliation, he or she shall immediately notify the Imperial County Planning and Development Services Department. The Imperial County Planning and Development Services Department shall consult with the professional archaeologist on a finding of eligibility and implement appropriate treatment measures if the find is determined to be an Historical Resource under CEQA, as defined in Section 15064.5(a) of the CEQA Guidelines, or an Historic Property, as defined in 36 CFR 60.4. Work may not resume within the no-work radius until the Imperial County Planning and Development Services Department, through consultation as appropriate, determine that the site either: 1) is not an Historical Resource under CEQA or an Historic Property under Section 106; or 2) that the treatment measures have been completed to their satisfaction. 	
<p>Impact 3.6-2: Substantial adverse change in the significance of an archaeological resource.</p>	<p>Significant</p>	<p>CR-3 Evaluate Significance of Find (Unknown Archaeological Resources). In the event of the discovery of previously unidentified archaeological materials, the contractor shall immediately cease all work activities within approximately 100 feet of the discovery. After cessation of excavation, the contractor shall immediately contact the Imperial County Department of Planning and Development Services Department. Except in the case of cultural items that fall within the scope of the Native American Grave Protection and Repatriation Act, the discovery of any cultural resource within the project area shall not be grounds for a “stop work” notice or otherwise interfere with the project’s continuation except as set forth in this paragraph.</p>	<p>Less than Significant</p>

Table ES-1. Summary of Project Impacts and Proposed Mitigation Measures

Environmental Impact	Significance Before Mitigation	Proposed Mitigation Measures	Significance After Mitigation
		<p>In the event of an unanticipated discovery of archaeological materials during construction, the applicant shall retain the services of a qualified professional archaeologist, meeting the Secretary of the Interior’s Standards for a Qualified Archaeologist, to evaluate the significance of the materials prior to resuming any construction-related activities in the vicinity of the find. If the qualified archaeologist determines that the discovery constitutes a significant resource under CEQA and it cannot be avoided, the applicant shall implement an archaeological data recovery program.</p>	
<p>Impact 3.6-3: Disturb human remains.</p>	<p>Significant</p>	<p>CR-4 Human Remains. If subsurface deposits believed to be human in origin are discovered during construction, all work must halt within a 100-foot radius of the discovery. A qualified professional archaeologist who meets the Secretary of the Interior’s Standards for prehistoric and historic archaeology and is familiar with the resources of the region, shall be retained to evaluate the significance of the find, and shall have the authority to modify the no work radius as appropriate, using professional judgment. The following notifications shall apply, depending on the nature of the find:</p> <ul style="list-style-type: none"> • If the find includes human remains, or remains that are potentially human, the professional archaeologist shall ensure reasonable protection measures are taken to protect the discovery from disturbance (AB 2641). The archaeologist shall notify the Imperial County Coroner (per § 7050.5 of the Health and Safety Code). The provisions of § 7050.5 of the California Health and Safety Code, § 5097.98 of the California PRC, and AB 2641 will be implemented. • If the Coroner determines the remains are Native American and not the result of a crime scene, the Coroner will notify the NAHC, which then will designate a Native American Most Likely Descendant (MLD) for the project (§ 5097.98 of the PRC). The designated MLD will have 48 hours from the time access to the property is granted to make recommendations concerning treatment of the remains. If the landowner does not agree with the recommendations of the MLD, 	<p>Less than Significant</p>



Table ES-1. Summary of Project Impacts and Proposed Mitigation Measures

Environmental Impact	Significance Before Mitigation	Proposed Mitigation Measures	Significance After Mitigation
		the NAHC may mediate (§ 5097.94 of the PRC). If no agreement is reached, the landowner must rebury the remains where they will not be further disturbed (§ 5097.98 of the PRC). This will also include either recording the site with the NAHC or the appropriate Information Center; using an open space or conservation zoning designation or easement; or recording a reinternment document with the county in which the property is located (AB 2641). Work may not resume within the no-work radius until the Imperial County Planning and Development Services Department, through consultation as appropriate, determine that the treatment measures have been completed to their satisfaction.	
Geology and Soils			
Impact 3.7-2: Possible risks to people and structures caused by strong seismic ground shaking.	Significant	GEO-1 Prepare Geotechnical Report(s) as Part of Final Engineering for the Project and Implement Required Measures. Facility design for all project components shall comply with the site-specific design recommendations as provided by a licensed geotechnical or civil engineer to be retained by the project applicant. The final geotechnical and/or civil engineering report shall address and make recommendations on the following: <ul style="list-style-type: none"> • Site preparation; • Soil bearing capacity; • Appropriate sources and types of fill; • Potential need for soil amendments; • Structural foundations; • Grading practices; • Soil corrosion of concrete and steel; • Erosion/winterization; • Seismic ground shaking; 	Less than Significant

Table ES-1. Summary of Project Impacts and Proposed Mitigation Measures

Environmental Impact	Significance Before Mitigation	Proposed Mitigation Measures	Significance After Mitigation
		<ul style="list-style-type: none"> • Liquefaction; and • Expansive/unstable soils. <p>In addition to the recommendations for the conditions listed above, the geotechnical investigation shall include subsurface testing of soil and groundwater conditions and shall determine appropriate foundation designs that are consistent with the version of the CBC that is applicable at the time building and grading permits are applied for. All recommendations contained in the final geotechnical engineering report shall be implemented by the project applicant. The final geotechnical and/or civil engineering report shall be submitted to Imperial County Public Works Department, Engineering Division for review and approval prior to issuance of building permits.</p>	
Impact 3.7-3: Possible risks to people and structures caused by seismic related ground failure, including liquefaction.	Significant	Implement Mitigation Measure GEO-1.	Less than Significant
Impact 3.7-5: Substantial soil erosion or the loss of topsoil.	Significant	Implement Mitigation Measures GEO-1 and HYD-1.	Less than Significant
Impact 3.7-6: Located on a geologic unit or soil that is unstable or that would become unstable as a result of the project, and potentially result in on- or off-site landslide, lateral spreading, subsidence, liquefaction, or collapse.	Significant	Implement Mitigation Measure GEO-1.	Less than Significant
Impact 3.7-7: Expansive soils.	Significant	Implement Mitigation Measure GEO-1.	Less than Significant
Impact 3.7-9: Directly or indirectly destroy paleontological resources.	Significant	GEO-2 Paleontological Resources. In the event that unanticipated paleontological resources or unique geologic resources are encountered during ground-disturbing activities, work must cease within 50 feet of the	Less than Significant



Table ES-1. Summary of Project Impacts and Proposed Mitigation Measures

Environmental Impact	Significance Before Mitigation	Proposed Mitigation Measures	Significance After Mitigation
		<p>discovery and a paleontologist shall be hired to assess the scientific significance of the find. The consulting paleontologist shall have knowledge of local paleontology and the minimum levels of experience and expertise as defined by the <i>Society of Vertebrate Paleontology's Standard Procedures (2010) for the Assessment and Mitigation of Adverse Impacts to Paleontological Resources</i>. If any paleontological resources or unique geologic features are found within the project site, the consulting paleontologist shall prepare a paleontological Treatment and Monitoring Plan to include the methods that will be used to protect paleontological resources that may exist within the project site, as well as procedures for monitoring, fossil preparation and identification, curation of specimens into an accredited repository, and preparation of a report at the conclusion of the monitoring program.</p>	
Hydrology/Water Quality			
<p>Impact 3.10-1: Violation of water quality standards.</p>	<p>Significant</p>	<p>HYD-1 Prepare SWPPP and Implement BMPs Prior to Construction and Site Restoration. The project applicant or its contractor shall prepare an SWPPP specific to the project and be responsible for securing coverage under SWRCB's NPDES stormwater permit for general construction activity (Order 2009-0009-DWQ). The SWPPP shall identify specific actions and BMPs relating to the prevention of stormwater pollution from project-related construction sources by identifying a practical sequence for site restoration, BMP implementation, contingency measures, responsible parties, and agency contacts. The SWPPP shall reflect localized surface hydrological conditions and shall be reviewed and approved by the appropriate agency prior to commencement of work and shall be made conditions of the contract with the contractor selected to build and decommission the project. The SWPPP shall incorporate control measures in the following categories:</p> <ul style="list-style-type: none"> • Soil stabilization and erosion control practices (e.g., hydroseeding, erosion control blankets, mulching) • Sediment control practices (e.g., temporary sediment basins, fiber rolls) 	<p>Less than Significant</p>

Table ES-1. Summary of Project Impacts and Proposed Mitigation Measures

Environmental Impact	Significance Before Mitigation	Proposed Mitigation Measures	Significance After Mitigation
		<ul style="list-style-type: none"> • Temporary and post-construction on- and off-site runoff controls • Special considerations and BMPs for water crossings and drainages • Monitoring protocols for discharge(s) and receiving waters, with emphasis place on the following water quality objectives: dissolved oxygen, floating material, oil and grease, potential of hydrogen (pH), and turbidity • Waste management, handling, and disposal control practices • Corrective action and spill contingency measures • Agency and responsible party contact information • Training procedures that shall be used to ensure that workers are aware of permit requirements and proper installation methods for BMPs specified in the SWPPP <p>The SWPPP shall be prepared by a Qualified SWPPP Practitioner and/or Qualified SWPPP Developer with BMPs selected to achieve maximum pollutant removal and that represent the best available technology that is economically achievable. Emphasis for BMPs shall be placed on controlling discharges of oxygen-depleting substances, floating material, oil and grease, acidic or caustic substances or compounds, and turbidity. BMPs for soil stabilization and erosion control practices and sediment control practices will also be required. Performance and effectiveness of these BMPs shall be determined either by visual means where applicable (i.e., observation of above-normal sediment release), or by actual water sampling in cases where verification of contaminant reduction or elimination, (inadvertent petroleum release) is required to determine adequacy of the measure.</p> <p>HYD-2 Incorporate Post-Construction Runoff, Source Control, and Treatment Control BMPs into Final Project Drainage Plan. The project's Final Drainage Plan shall adhere to the County's Engineering Guidelines Manual, IID "Draft" Hydrology Manual, or other recognized</p>	



Table ES-1. Summary of Project Impacts and Proposed Mitigation Measures

Environmental Impact	Significance Before Mitigation	Proposed Mitigation Measures	Significance After Mitigation
		source with approval by the County Engineer to control and manage the on- and off-site discharge of stormwater to existing drainage systems. The Final Drainage Plan shall provide both short- and long-term drainage solutions to ensure the proper sequencing of drainage facilities and shall include source control and treatment BMPs to adequately treat collected runoff prior to discharge, as necessary.	
Impact 3.10-3: Result in substantial erosion or siltation on or off site.	Significant	Implement Mitigation Measure HYD-1.	Less than Significant
Impact 3.10-4: Substantially increase the rate or amount of surface runoff in a manner which would result in flooding on or off site.	Significant	Implement Mitigation Measure HYD-1.	Less than Significant
Impact 3.10-5: Create or contribute runoff water which would exceed the capacity of existing or planned stormwater drainage systems or provide substantial additional sources of polluted runoff.	Significant	Implement Mitigation Measures HYD-1 and HYD-2.	Less than Significant
Impact 3.10-8: Conflict with or obstruct implementation of a water quality control plan or sustainable groundwater management plan.	Significant	Implement Mitigation Measures HYD-1 and HYD-2.	Less than Significant

This page is intentionally blank.

Statement of Overriding Considerations

CEQA Guidelines Section 15093 requires the Lead Agency to balance, as applicable, the economic, legal, social, and technological, or other benefits of the project against its unavoidable environmental risks when determining whether to approve the project. No significant and unmitigated impacts have been identified for the proposed project; therefore, the County would not be required to adopt a Statement of Overriding Considerations pursuant to Section 15093 for this project.

Project Alternatives

Alternatives Considered but Rejected

Alternative Site

Section 15126.6(f)(2) of the CEQA Guidelines addresses alternative locations for a project. The key question and first step in the analysis is whether any of the significant effects of the proposed project would be avoided or substantially lessened by constructing the proposed project in another location. Only locations that would avoid or substantially lessen any of the significant effects of the project need to be considered for inclusion in the EIR. Further, CEQA Guidelines Section 15126.6(f)(1) states that among the factors that may be taken into account when addressing the feasibility of alternative locations are whether the project proponent can reasonably acquire, control or otherwise have access to the alternative site (or the site is already owned by the proponent).

The project applicant does not have control of an alternate site; if control were viable, the proponent would have to re-initiate the application process as a new project. Similar to the proposed project site, an alternate site would require environmental review once the proponent has prepared sufficient project description information. At present, the proponent does not have control of an alternate site. This alternative would be the most complex, costly, and time-consuming alternative to implement. It is unknown if the environmental impacts associated with this Alternative would be less than the proposed project because it would be speculative to evaluate an unsecured alternate site. This is primarily due to the fact that the project applicant does not have control of an alternate site. Therefore, an alternative site was eliminated from further consideration in this EIR.

Original Site Plan Submittal

The project applicant originally proposed to construct and operate a 100 MW solar energy facility with an integrated 100 MW BESS on approximately 531 acres (APNs 059-290-010, 059-300-015, and 059-300-017). Based on a biological reconnaissance survey of the 531-acre site, the following sensitive vegetation communities were found to be present on the western parcel (APN 059-209-010): arrow weed thickets, tamarisk thickets, and alkali weed – salt grass playas and sinks. Furthermore, one freshwater emergent wetland occurs on the western parcel. To minimize impacts on biological resources, the project applicant re-designed the project to remove the western parcel (APN 059-209-010). The western parcel would not be developed. This re-design reduced the original project site from 531 acres to 450 acres.

The original site plan on 531 acres would result in increased biological resources impacts and increased jurisdictional water impacts compared to the proposed project. Therefore, the County rejects to original site plan from further analysis.

Original Access Route for Heavy Construction Equipment

The project applicant's originally proposed access route for heavy construction equipment was via State Route 98 east to the East Highline Check of the All-American Canal bridge crossing to the project entrance. After coordination with the IID, IID determined that the bridge crossing would not be able to handle the weight of heavy construction equipment.

Although the use of the original access route would be a shorter distance to the project site and would result in less miles traveled, the County rejects the original access route from further analysis due to increased hazards and safety impacts.

Alternatives Evaluated

The environmental analysis for the proposed project evaluated the potential environmental impacts resulting from implementation of the proposed project, as well as alternatives to the project. The alternatives include Alternative 1: No Project/No Development and Alternative 2: Reduced Project Site. A detailed discussion of the alternatives considered is included in Chapter 7. Table ES-2 summarizes the impacts resulting from the proposed project and the identified alternatives.

Alternative 1: No Project/No Development Alternative

The CEQA Guidelines require analysis of the No Project Alternative (PRC Section 15126). According to Section 15126.6(e), "the specific alternative of 'no project' shall also be evaluated along with its impacts. The 'no project' analysis shall discuss the existing conditions at the time the Notice of Preparation is published, at the time environmental analysis is commenced, as well as what would be reasonably expected to occur in the foreseeable future if the project were not approved, based on current plans and consistent with available infrastructure and community services."

The No Project/No Development Alternative assumes that the project, as proposed, would not be implemented and the project site would not be developed.

The No Project/No Development Alternative would not meet a majority of the objectives of the project. Additionally, the No Project/No Development Alternative would not help California meet its statutory and regulatory goal of increasing renewable power generation, including GHG reduction goals of Senate Bill 32.

Alternative 2: Reduced Project Site

The purpose of this alternative is to reduce the size of the project site to minimize impacts on biological resources by increasing the setback of the project from sensitive vegetation communities and aquatic resources. Tamarisk thickets, identified by CDFW as a sensitive natural community, have been mapped on the northern parcel (APN 059-300-015) of the project site. Freshwater forested/shrub wetland, riparian habitat, and disturbed riparian habitat have also been mapped on the northern parcel of the project site. This alternative would remove the northern parcel (APN 059-300-015), thereby reducing the project site by 301 acres from 450 acres to 149 acres.

As shown in Table ES-2, this alternative would reduce impacts to agricultural resources, air quality, biological resources, cultural resources, hydrology/water quality, and utilities/service systems. Alternative 2 would meet most of the basic objectives of the proposed project and should remain under consideration. However, this alternative would make it more difficult to achieve the overall objective of providing a total of 100 MW of renewable solar energy, as there would be less area available for the placement of PV structures.



Environmentally Superior Alternative

The No Project/No Development Alternative would be considered the environmentally superior alternative, since it would eliminate all of the significant impacts identified for the project. However, CEQA Guidelines Section 15126.6(e)(2) states that “if the environmentally superior alternative is the No Project Alternative, the EIR shall also identify an environmentally superior alternative among the other alternatives.” As shown in Table ES-2, Alternative 2 would reduce impacts for the following environmental issue areas as compared to the proposed project: agricultural resources, air quality, biological resources, cultural resources, hydrology/water quality, and utilities/service systems. Therefore, Alternative 2 is considered the Environmentally Superior Alternative.

This page is intentionally blank.



Table ES-2. Comparison of Alternative Impacts to Proposed Project

Environmental Issue Area	Proposed Project	Alternative 1: No Project/No Development	Alternative 2: Reduced Project Site
Aesthetics and Visual Resources	Less than Significant	<i>CEQA Significance:</i> No Impact <i>Comparison to Proposed Project:</i> Less Impact	<i>CEQA Significance:</i> Less than Significant <i>Comparison to Proposed Project:</i> Similar Impact
Agricultural Resources	Less than Significant with Mitigation	<i>CEQA Significance:</i> No Impact <i>Comparison to Proposed Project:</i> Less Impact (Avoid)	<i>CEQA Significance:</i> Less than Significant with Mitigation <i>Comparison to Proposed Project:</i> Less Impact
Air Quality	Less than Significant with Mitigation	<i>CEQA Significance:</i> No Impact <i>Comparison to Proposed Project:</i> Less Impact	<i>CEQA Significance:</i> Less than Significant with Mitigation <i>Comparison to Proposed Project:</i> Less Impact
Biological Resources	Less than Significant with Mitigation	<i>CEQA Significance:</i> No Impact <i>Comparison to Proposed Project:</i> Less Impact (Avoid)	<i>CEQA Significance:</i> Less than Significant with Mitigation <i>Comparison to Proposed Project:</i> Less Impact
Cultural Resources	Less than Significant with Mitigation	<i>CEQA Significance:</i> No Impact <i>Comparison to Proposed Project:</i> Less Impact (Avoid)	<i>CEQA Significance:</i> Less than Significant with Mitigation <i>Comparison to Proposed Project:</i> Less Impact
Geology and Soils	Less than Significant with Mitigation	<i>CEQA Significance:</i> No Impact <i>Comparison to Proposed Project:</i> Less Impact (Avoid)	<i>CEQA Significance:</i> Less than Significant with Mitigation <i>Comparison to Proposed Project:</i> Similar Impact
GHG Emissions	Less than Significant	<i>CEQA Significance:</i> No Impact <i>Comparison to Proposed Project:</i> Less Impact	<i>CEQA Significance:</i> Less than Significant <i>Comparison to Proposed Project:</i> Similar Impact

Table ES-2. Comparison of Alternative Impacts to Proposed Project

Environmental Issue Area	Proposed Project	Alternative 1: No Project/No Development	Alternative 2: Reduced Project Site
Hazards and Hazardous Materials	Less than Significant	<i>CEQA Significance:</i> No Impact <i>Comparison to Proposed Project:</i> Less Impact	<i>CEQA Significance:</i> Less than Significant <i>Comparison to Proposed Project:</i> Similar Impact
Hydrology/ Water Quality	Less than Significant with Mitigation	<i>CEQA Significance:</i> No Impact <i>Comparison to Proposed Project:</i> Less Impact (Avoid)	<i>CEQA Significance:</i> Less than Significant with Mitigation <i>Comparison to Proposed Project:</i> Less Impact
Land Use/Planning	No Impact	<i>CEQA Significance:</i> No Impact <i>Comparison to Proposed Project:</i> Similar Impact	<i>CEQA Significance:</i> No Impact <i>Comparison to Proposed Project:</i> Similar Impact
Noise and Vibration	Less than Significant	<i>CEQA Significance:</i> No Impact <i>Comparison to Proposed Project:</i> Less Impact	<i>CEQA Significance:</i> Less than Significant <i>Comparison to Proposed Project:</i> Similar Impact
Transportation	Less than Significant	<i>CEQA Significance:</i> No Impact <i>Comparison to Proposed Project:</i> Less Impact	<i>CEQA Significance:</i> Less than Significant <i>Comparison to Proposed Project:</i> Similar Impact
Tribal Cultural Resources	Less than Significant	<i>CEQA Significance:</i> No Impact <i>Comparison to Proposed Project:</i> Less Impact	<i>CEQA Significance:</i> Less than Significant <i>Comparison to Proposed Project:</i> Similar Impact
Utilities/Service Systems	Less than Significant	<i>CEQA Significance:</i> No Impact <i>Comparison to Proposed Project:</i> Less Impact	<i>CEQA Significance:</i> Less than Significant <i>Comparison to Proposed Project:</i> Less Impact

1 Introduction

This environmental impact report (EIR) has been prepared to meet the requirements of the California Environmental Quality Act (CEQA) for purposes of evaluating the potential environmental impacts, mitigation measures, and alternatives associated with the proposed VEGA SES 4 Solar Energy Project. This EIR describes the existing environment that would be affected by, and the environmental impacts which could potentially result from the construction and operation of the proposed project as described in detail in Chapter 2.0 of this EIR.

1.1 Overview of the Proposed Project

The project site is located on approximately 450 acres of privately-owned land in the southernmost portion of Imperial County, California. The project site is between the U.S./Mexico international border and the All-American Canal, on the California side. The project site is proposed on two parcels (Assessor Parcel Numbers 059-300-015 and 059-300-017) that are contiguous with each other.

The proposed project consists of three primary components: 1) solar energy generation equipment and associated facilities including a substation and access roads (herein referred to as “solar energy facility”); 2) battery energy storage system (BESS); and 3) gen-tie line that would connect the proposed on-site substation to the point of interconnection at the existing Imperial Irrigation District’s (IID) 92-kV “P” line.

The proposed project involves the construction of a 100-megawatt (MW) alternating current (AC) photovoltaic (PV) solar energy facility with an integrated 100 MW battery storage system (not to exceed 200 MW) on approximately 450 acres of land. The project proposes to utilize either thin film or crystalline solar PV technology modules mounted either on fixed frames or horizontal single-axis tracker systems. The project would include electronic/electrical equipment, an on-site substation, access road(s) and fencing. The electrical energy produced by the project would be conducted through the project’s interconnection facilities to the proposed 92 kV generator intertie (gen-tie) line and delivered to the existing IID approved point of interconnection on the 92-kV “P” Line located immediately north of the project site and the All-American Canal.

1.1.1 Agency Roles and Responsibilities

This section identifies and summarizes federal, state, and local laws, policies, and regulations that are applicable to the project.

County of Imperial

Implementation of the project would involve the following approvals by the County of Imperial:

1. **Approval of Conditional Use Permit (CUP) – Solar Energy Facility.** Implementation of the project would require the approval of a CUP by the County to allow for the construction and operation of the proposed solar energy facility with an integrated BESS. The project site is located on two privately-owned legal parcels zoned Heavy Agriculture with a Renewable Energy Zone Overlay (A-3-RE). Pursuant to Title 9, Division 5, Chapter 9, the following uses are permitted in the A-3 zone subject to approval of a CUP from Imperial County:

i) Battery Storage Facility (must be connected to an existing electrical power generation plant such as solar, geothermal, wind, natural gas, or other renewable energy generator, as an accessory unit to said power plant).

oo) Major facilities relating to the generation and transmission of electrical energy, provided such facilities are not under State or Federal law, to [be] approved exclusively by an agency, or agencies of the State or Federal government, and provided such facilities shall be approved subsequent to coordination review of the Imperial Irrigation District for electrical matters, meeting the requirements in Division 17.

zz) Solar energy plants meeting the requirements in Division 17.

2. **Certification of the EIR.** After the required public review for the Draft EIR, the County will respond to written comments, edit the document, and produce a Final EIR to be certified by the Planning Commission and Board of Supervisors prior to making a decision on the project.

Subsequent ministerial approvals may include, but are not limited to:

- Grading and clearing permits
- Building permits
- Reclamation plan
- Encroachment permits
- Transportation permit(s)

Other Agencies Reviews and/or Consultations

The following agencies may be involved in reviewing and/or consultations with the project proponent as it relates to construction of the project:

Federal

UNITED STATES FISH AND WILDLIFE SERVICE

- The United States Fish and Wildlife Service (USFWS) enforces compliance with regulations related to special-status species or their habitat as required under the Federal Endangered Species Act (ESA).

UNITED STATES ARMY CORPS OF ENGINEERS

- Section 404 Permit (Clean Water Act [CWA]). The CWA establishes a program to regulate the discharge of dredge and fill material into waters of the U.S. including wetlands. Activities regulated under this program include fills for development, water resource projects (e.g., dams and levees), infrastructure development (e.g., highways and airports), and conversion of wetlands to uplands for farming and forestry. Either an individual 404b permit or authorization to use an existing USACE Nationwide Permit will need to be obtained if any portion of the construction requires fill into a river, stream, or stream bed that has been determined to be a jurisdictional waterway.



UNITED STATE BORDER PATROL

- The project applicant and U.S. Border Patrol will develop and enter into a Memorandum of Understanding (MOU) setting forth the project-related activities that may occur on an existing dirt road used by the U.S. Border Patrol.

State

CALIFORNIA DEPARTMENT OF FISH AND WILDLIFE (TRUSTEE AGENCY)

- The California Department of Fish and Wildlife (CDFW) is a Trustee Agency and enforces compliance with regulations related to California special-status species or their habitats as required under the California Endangered Species Act (CESA).

CALIFORNIA REGIONAL WATER QUALITY CONTROL BOARD

- **National Pollution Discharge Elimination System Construction General Permit Order No. 2009-009-DWQ.** Requires the applicant to file a public Notice of Intent to discharge stormwater and to prepare and implement a stormwater pollution prevention plan (SWPPP).
- **Jurisdictional Waters.** Agencies and/or project proponents must consult with the California Regional Water Quality Control Board (RWQCB) regarding, when applicable, regarding compliance with the CWA Section 401 Water Quality Certification or permitting under California Porter-Cologne Act.

Local

IMPERIAL COUNTY FIRE DEPARTMENT

- Review as part of the EIR process including the final design of the proposed fire system.

IMPERIAL COUNTY AIR POLLUTION CONTROL DISTRICT

- Review as part of the EIR process regarding consistency with the Imperial County Air Pollution Control District (ICAPCD) CEQA Air Quality Handbook, the final “Modified” 2009 8-hour Ozone Air Quality Management Plan, the State Implementation Plan for particulate matter less than 10 microns in diameter (PM₁₀) in the Imperial Valley, the State Implementation Plan (SIP) for particulate matter less than 2.5 microns in diameter (PM_{2.5}), and verification of Rule 801 compliance.

1.2 Relationship to Statutes, Regulations, and Other Plans

1.2.1 County of Imperial General Plan and Land Use Ordinance

The General Plan provides guidance on future growth in the County of Imperial. Any development in the County of Imperial must be consistent with the General Plan and Land Use Ordinance (Title 9, Division 10).

1.2.2 Renewables Portfolio Standard Program

Established in 2002 under Senate Bill (SB) 1078, California’s Renewables Portfolio Standard (RPS) was accelerated in 2006 under SB 107 by requiring that 20 percent of electricity retail sales be served by RE resources by 2010. RE sources include wind, geothermal, and solar. Subsequent

recommendations in California energy policy reports advocated a goal of 33 percent by 2020. On November 17, 2008, Governor Arnold Schwarzenegger signed Executive Order (EO) S-14-08 requiring that "... all retail sellers of electricity shall serve 33 percent of their load with RE by 2020." The following year, EO S-21-09 directed the California Air Resources Board (CARB), under its Assembly Bill (AB) 32 authority, to enact regulations to achieve the goal of 33 percent renewables by 2020.

In the ongoing effort to codify the ambitious 33 percent by 2020 goal, SB X12 was signed by Governor Brown, in April 2011. This new RPS preempts the CARB's 33 percent Renewable Electricity Standard and applies to all electricity retailers in the state including publicly owned utilities, investor-owned utilities, electricity service providers, and community choice aggregators. All of these entities had to adopt the new RPS goals of 20 percent of retail sales from renewables by the end of 2013, 25 percent by the end of 2016, and the 33 percent requirement being met by the end of 2020.

Governor Brown signed into legislation SB 350 in October 2015, which requires retail sellers and publicly owned utilities to procure 50 percent of their electricity from eligible RE resources by 2030. In 2018, SB 100 was signed by Governor Brown, codifying a goal of 60 percent renewable procurement by 2030 and 100 percent by 2045 Renewables Portfolio Standard.

1.2.3 Senate Bill 32

In August 2016, Governor Brown signed SB 32 and AB 197, which serve to extend California's GHG reduction programs beyond 2020. SB 32 amended the Health and Safety Code to include § 38566, which contains language to authorize CARB to achieve a statewide GHG emission reduction of at least 40 percent below 1990 levels by no later than December 31, 2030. SB 32 codified the targets established by Executive Order (EO) B-30-15 for 2030, which set the next interim step in the State's continuing efforts to pursue the long-term target expressed in EOs S-3-05 and B-30-15 of 80 percent below 1990 emissions levels by 2050.

1.2.4 Title 17 California Code of Regulations, Subchapter 10, Article 2, Sections 95100 et seq.

These CARB regulations implement mandatory GHG emissions reporting as part of the California Global Warming Solutions Act of 2006.

1.2.5 Federal Clean Air Act

The legal authority for federal programs regarding air pollution control is based on the 1990 Clean Air Act (CAA) Amendments. These are the latest in a series of amendments made to the CAA. This legislation modified and extended federal legal authority provided by the earlier Clean Air Acts of 1963, 1970, and 1977.

The Air Pollution Control Act of 1955 was the first Federal legislation involving air pollution. This Act provided funds for federal research in air pollution. The CAA of 1963 was the first Federal legislation regarding air pollution control. It established a federal program within the U.S. Public Health Service and authorized research into techniques for monitoring and controlling air pollution. In 1967, the Air Quality Act was enacted in order to expand Federal government activities. In accordance with this law, enforcement proceedings were initiated in areas subject to interstate air pollution transport. As part of these proceedings, the Federal government for the first time conducted extensive ambient monitoring studies and stationary source inspections.

The Air Quality Act of 1967 also authorized expanded studies of air pollutant emission inventories, ambient monitoring techniques, and control techniques.

1.2.6 Imperial County Air Pollution Control District

The ICAPCD enforces rules and regulations regarding air emissions associated with various activities, including construction and farming, and operational activities associated with various land uses, in order to protect the public health.

1.2.7 Federal Clean Water Act (33 United States Code Sections 1251–1387)

The Federal Water Pollution Control Act (33 United States Code [USC] §§1251-1387), otherwise known as the CWA, is a comprehensive statute aimed at restoring and maintaining the chemical, physical and biological integrity of the nation's waters. Enacted originally in 1948, the Act was amended numerous times until it was reorganized and expanded in 1972. It continues to be amended almost every year. Primary authority for the implementation and enforcement of the CWA rests with the U.S. Environmental Protection Agency (EPA). In addition to the measures authorized before 1972, the Act authorizes water quality programs, requires federal effluent limitations and state water quality standards, requires permits for the discharge of pollutants into navigable waters, provides enforcement mechanisms, and authorizes funding for wastewater treatment works construction grants and state revolving loan programs, as well as funding to states and tribes for their water quality programs. Provisions have also been added to address water quality problems in specific regions and specific waterways.

Important for wildlife protection purposes are the provisions requiring permits to dispose of dredged and fill materials into navigable waters. Permits are issued by the United States Army Corps of Engineers (USACE) under guidelines developed by EPA pursuant to Section 404 of the CWA.

1.2.8 Federal Clean Water Act and California Porter-Cologne Water Quality Control Act

The project is located within the Colorado River Basin RWQCB, Region 7. The CWA and the California Porter-Cologne Water Quality Control Act require that Water Quality Control Plans (more commonly referred to as Basin Plans) be prepared for the nine state-designated hydrologic basins in California. The Basin Plan serves to guide and coordinate the management of water quality within the region.

1.2.9 Federal Endangered Species Act

The ESA (16 USC 1531-1544) provides protection for plants and animals whose populations are dwindling to levels that are no longer sustainable in the wild. The Act sets out a process for listing species, which allows for petition from any party to list a plant or animal. Depending on the species, USFWS or the National Marine Fisheries Service (NMFS) will determine whether listing the species is warranted. If it is warranted, the species will be listed as either threatened or endangered. The difference between the two categories is one of degree, with endangered species receiving more protections under the statute.

1.2.10 National Historic Preservation Act

Federal regulations (36 Code of Federal Regulations [CFR] Part 800.2) define historic properties as "any prehistoric or historic district, site, building, structure, or object included, or eligible for inclusion in, in the National Register of Historic Places (NRHP)." The term "cultural resource" is used to denote a historic or prehistoric district, site, building, structure, or object, regardless of whether it is eligible for the NRHP.

1.2.11 California Endangered Species Act

CESA is enacted through Government Code Section 2050. Section 2080 of the California Fish and Game Code (FGC) prohibits "take" of any species that the commission determines to be an endangered species or a threatened species. Take is defined in Section 86 of the FGC as "hunt, pursue, catch, capture, or kill, or attempt to hunt, pursue, catch, capture, or kill."

CESA allows for take incidental to otherwise lawful development projects. CESA emphasizes early consultation to avoid potential impacts to rare, endangered, and threatened species and to develop appropriate mitigation planning to offset project-caused losses of listed species populations and their essential habitats.

1.2.12 California Lake and Streambed Program (Fish and Game Code Section 1602)

CDFW is responsible for conserving, protecting, and managing California's fish, wildlife, and native plant resources. To meet this responsibility, the FGC (Section 1602) requires an entity to notify CDFW of any proposed activity that may substantially modify a river, stream, or lake.

1.3 Purpose of an EIR

The purpose of an EIR is to analyze the potential environmental impacts associated with a project. CEQA (Section 15002) states that the purpose of CEQA is to: (1) inform the public and governmental decision makers of the potential, significant environmental impacts of a project; (2) identify the ways that environmental damage can be avoided or significantly reduced; (3) prevent significant, avoidable damage to the environment by requiring changes in projects through the use of alternatives or mitigation measures when the governmental agency finds the changes to be feasible; and (4) disclose to the public the reasons why a governmental agency approved the project in the manner the agency chose if significant environmental effects are involved.

1.4 EIR Process

1.4.1 Availability of Reports

~~This~~ The Draft EIR has been distributed to various federal, state, regional, local agencies and interested parties for a 45-day public review period, from November 22, 2022, through January 10, 2023, in accordance with Section 15087 of the CEQA Guidelines. ~~This~~ The Draft EIR and documents incorporated by reference are ~~were~~ made available for public review at the County of Imperial Planning and Development Services Department, 801 Main Street, El Centro, California 92243. Documents ~~may be reviewed~~ were available for review during regular business hours.

David Black, Planner IV
County of Imperial, Planning and Development Services Department
801 Main Street
El Centro, California 92243

Comments received during the public review period of the Draft EIR ~~will be~~ have been reviewed and responded to in ~~the~~ this Final EIR. The Final EIR will ~~then~~ be reviewed by the Imperial County Planning Commission and Board of Supervisors as a part of the procedure to ~~adopt~~ certify the Final EIR. Additional information on this process may be obtained by contacting the County of Imperial Planning and Development Services Department at (442) 265-1736.

1.4.2 Public Participation Opportunities/Comments and Coordination

Notice of Preparation

The County of Imperial issued a notice of preparation (NOP) for the preparation of an EIR for the VEGA SES 4 Solar Energy Project on May 4, 2021. The NOP was distributed to city, county, state, and federal agencies, other public agencies, and various interested private organizations and individuals in order to define the scope of the EIR. The NOP was also published in the Imperial Valley Press on May 4, 2021, and in the Calexico Chronicles on May 6, 2021. The purpose of the NOP was to identify public agency and public concerns regarding the potential impacts of the project, and the scope and content of environmental issues to be addressed in the EIR. Correspondence in response to the NOP was received from the following entities and persons:

- Imperial Irrigation District
- Imperial County Air Pollution Control District
- Imperial County Department of Public Works
- Native American Heritage Commission

The comments submitted on the NOP during the public review and comment period are included as Appendix A to this EIR.

Scoping Meeting and Environmental Evaluation Committee

During the NOP public review period, the VEGA SES 4 Solar Energy Project was discussed as an informational item at the County's Environmental Evaluation Committee meeting on May 13, 2021.

Additionally, a virtual scoping meeting for the general public as well public agencies was held on May 13, 2021, at 6:00 p.m., to further obtain input as to the scope of environmental issues to be examined in the EIR. The NOP, which included the scoping meeting date and location, was published in the Imperial Valley Press on May 4, 2021, and in the Calexico Chronicles on May 6, 2021. A virtual meeting was held by the Imperial County Planning & Development Services Department. At the scoping meeting, members of the public were invited to ask questions regarding the proposed project and the environmental review process, and to comment both verbally and in writing on the scope and content of the EIR. No written or verbal comments were received during the scoping meeting.

1.4.3 Environmental Topics Addressed

Based on the analysis presented in the NOP and the information provided in the comments to the NOP, the following environmental topics are analyzed in this EIR.

- Aesthetics
- Agriculture Resources
- Air Quality
- Biological Resources
- Cultural Resources
- Geology and Soils
- GHG Emissions
- Hazards and Hazardous Materials
- Hydrology/Water Quality
- Land Use and Planning
- Noise and Vibration
- Transportation
- Tribal Cultural Resources
- Utilities/Service Systems (Water Supply)

Eliminated from Further Review in Notice of Preparation

The initial study (IS)/NOP completed by the County (Appendix A of this EIR) determined that environmental effects to Forestry Resources, Energy, Mineral Resources, Population/Housing, Public Services, Recreation, Utilities (Wastewater, Stormwater, and Solid Waste), and Wildfire would not be potentially significant. Therefore, these impacts are not addressed in this EIR; however, the rationale for eliminating these issues is discussed in Chapter 6.0, Effects Found Not Significant.

1.4.4 Areas of Controversy and Issues to be Resolved

Section 15123(b)(2) of the CEQA Guidelines requires that an EIR identify areas of controversy known to the Lead Agency, including issues raised by other agencies and the public as well as issues to be resolved. A primary issue associated with this solar farm project, and other solar facility projects that are proposed in the County, is the corresponding land use compatibility and fiscal/economic impacts to the County. Through the environmental review process for this project, other areas of concern and issues to be resolved include impacts on IID drains, project site access for construction workers, construction vehicles and equipment, and operational requirements (e.g., periodic maintenance and emergency response access), and U.S./Mexico border patrol operations.

1.4.5 Document Organization

The structure of the ~~Draft-Final~~ EIR is identified below. The ~~Draft-Final~~ EIR is organized into 14-14 chapters, including the Executive Summary.

- **Chapter 0.1 Introduction and Summary** describes the CEQA requirements and content of the Final EIR.
- **Chapter 0.2 Responses to Comment Letters Received on the Draft EIR** provides copies of the comment letters received and individual responses to written comments.
- **Chapter 0.3 Errata to the Draft EIR** identifies the location of, or contains revisions to, information included in the Draft EIR dated November 2022, based upon additional or revised information required to prepare a response to a specific comment.
- **Chapter 0.4 Mitigation Monitoring and Reporting Program** identifies the mitigation measures, timing, and responsibility for implementation of the measures.

- The **Executive Summary** provides a summary of the proposed project, including a summary of project impacts, mitigation measures, and project alternatives.
- **Chapter 1 Introduction** provides a brief introduction of the proposed project; relationship to statutes, regulations and other plans; the purpose of an EIR; public participation opportunities; availability of reports; and comments received on the NOP.
- **Chapter 2 Project Description** provides a description of the VEGA SES 4 Solar Energy Facility Project. This chapter also defines the goals and objectives of the proposed project, provides details regarding the individual components that together comprise the project, and identifies the discretionary approvals required for implementation of the project.
- **Chapter 3 Environmental Analysis** provides a description of the existing environmental setting and conditions, an analysis of the environmental impacts of the project for the following environmental issues: aesthetics; agricultural resources; air quality; biological resources; cultural resources; geology and soils; GHG emissions; hazards and hazardous materials; hydrology/water quality; land use and planning; noise and vibration; transportation; tribal cultural resources; and utilities/service systems. This chapter also identifies mitigation measures to address potential impacts to the environmental issues identified above.
- **Chapter 4 Analysis of Long-Term Effects** provides an analysis of growth inducing impacts, significant irreversible environmental changes, and unavoidable adverse impacts.
- **Chapter 5 Cumulative Impacts** discusses the impact of the proposed project in conjunction with other planned and future development in the surrounding areas.
- **Chapter 6 Effects Found Not to be Significant** lists all the issues determined to not be significant as a result of the preparation of this EIR.
- **Chapter 7 Alternatives** analyzes the alternatives to the proposed project.
- **Chapter 8 References** lists the data references utilized in preparation of the EIR.
- **Chapter 9 EIR Preparers and Organizations Contacted** lists all the individuals and companies involved in the preparation of the EIR, as well as the individuals and agencies consulted and cited in the EIR.

This page is intentionally blank.



2 Project Description

Chapter 2 provides a description of the VEGA SES 4 Solar Energy Project. This chapter also defines the goals and objectives of the proposed project, provides details regarding the individual components that together comprise the project, and identifies the discretionary approvals required for project implementation.

The proposed project consists of three primary components: 1) solar energy generation equipment and associated facilities including a substation and access roads (herein referred to as “solar energy facility”); 2) battery energy storage system (BESS); and 3) gen-tie line that would connect the proposed on-site substation to the point of interconnection at the existing IID 92-kV “P” line. The solar energy facility, BESS and gen-tie are collectively referred to as the “proposed project” or “project.”

2.1 Project Location

The project site is located on approximately 450 acres of privately-owned land in the southernmost portion of Imperial County, California (Figure 2-1). The project site is between the U.S./Mexico international border and the All-American Canal, on the California side. It is approximately 10 miles east of the City of Calexico in Sections 10, 11, 14, 15, and 16 within Township 17 South, and Range 16 East of the San Bernardino Base and Meridian of the Bonds Corner topographic 7.5-minute quadrangle. The irregular shaped project site is bound by undeveloped land, portions of which have been disturbed associated with previous agricultural-related activities to the west and east, the All-American Canal running southwest on the northern border of the project site, and the U.S./Mexico international border to the south. The project site is currently characterized by flat and undeveloped land, portions of which have been disturbed associated with previous agricultural-related activities.

2.1.1 Solar Energy Facility

As depicted on Figure 2-2, the solar energy facility site is proposed on two parcels that are contiguous with each other. Table 2-1 identifies the individual assessor parcel numbers (APN) with their respective acreage and zoning.

Table 2-1. Solar Energy Facility Site Assessor Parcel Numbers, Acreages, and Zoning

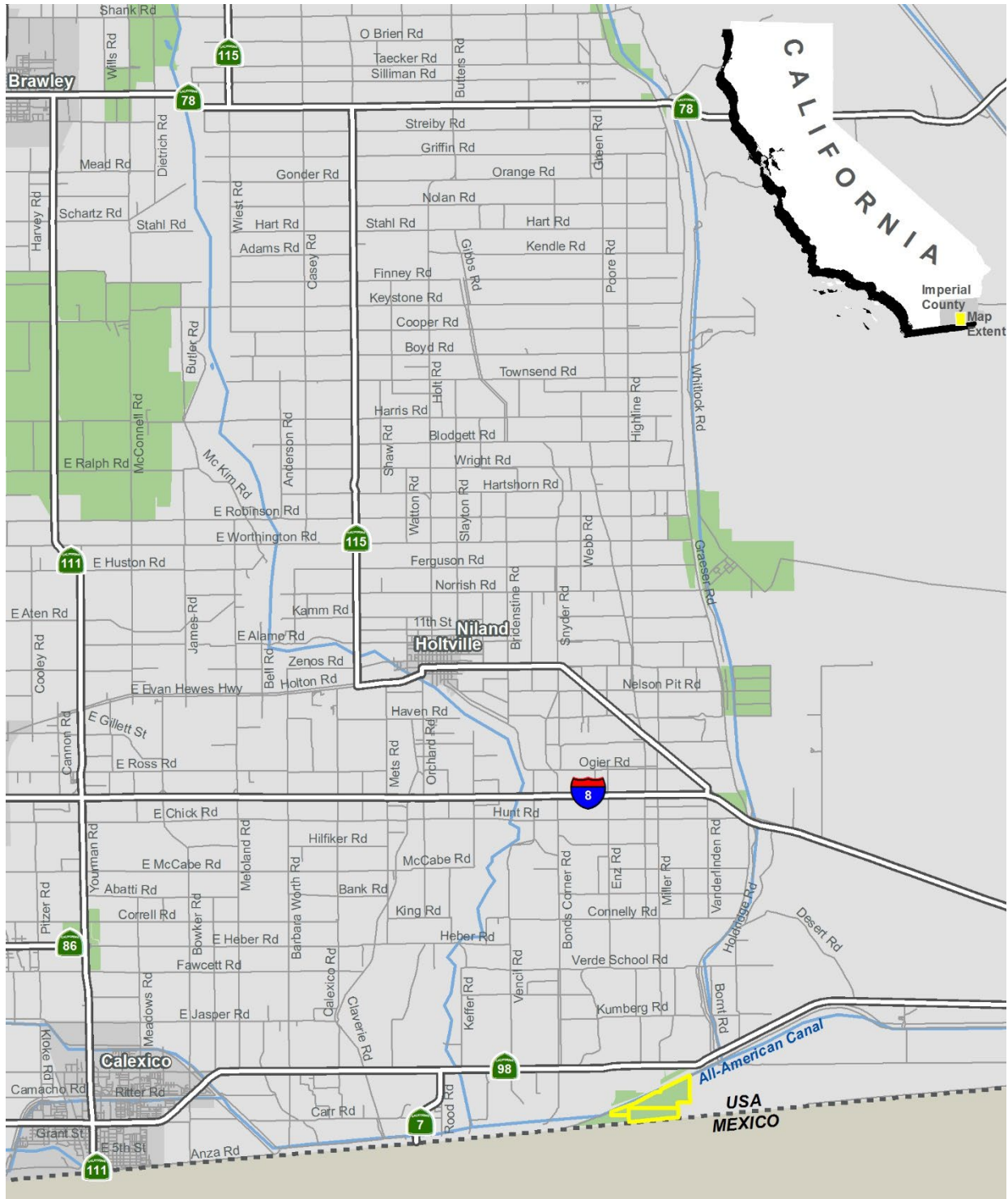
APN	Acreage	Zoning
059-300-015	301.73	A-3-RE
059-300-017	148.88	A-3-RE
Total Gross Acres	450.61	--

APN = assessor parcel number; A-3-RE = Heavy Agriculture with a Renewable Energy Zone Overlay

2.1.2 Battery Energy Storage System

The project includes a BESS within the northeastern portion of the solar energy facility site (APN 059-300-015).

Figure 2-1. Regional Location

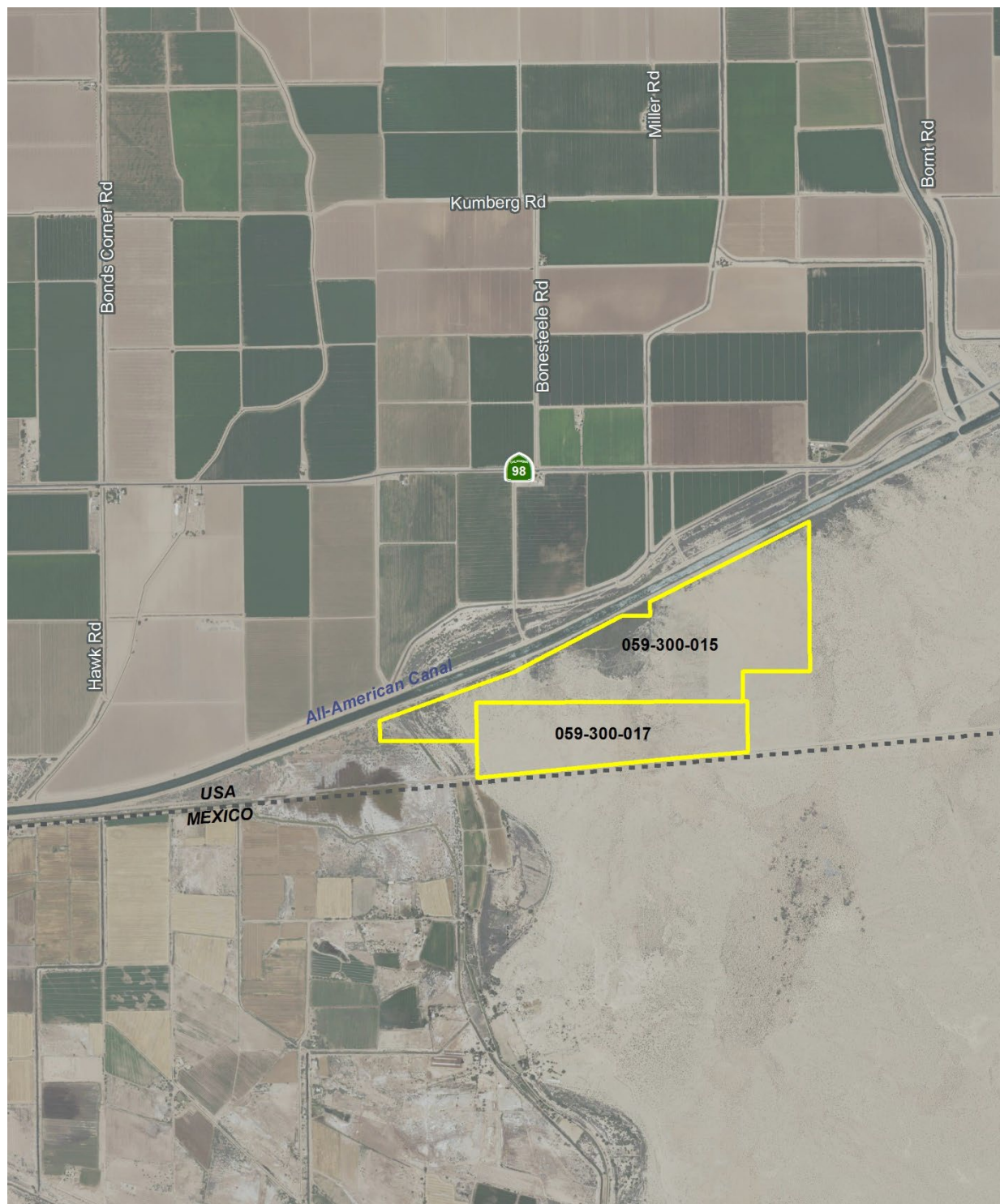


Legend

- VEGA SES 4 Project Area
- Renewable Energy Overlay Zone



Figure 2-2. Project Site



Legend

 VEGA SES 4 Project Parcels



0 Feet 2,000

2.1.3 Gen-Tie Line

The electrical energy produced by the project would be conducted through the project's interconnection facilities to the proposed 92 kV generator intertie (gen-tie) line and delivered to the existing IID approved point of interconnection (POI) on the 92 kV "P" Line located immediately north of the project site and the All-American Canal.

2.1.4 Renewable Energy Overlay Zone

In 2016, the County adopted the Imperial County Renewable Energy and Transmission Element, which includes an RE Zone (RE Overlay Map). This General Plan element was created as part of the California Energy Commission Renewable Energy Grant Program to amend and update the County's General Plan to facilitate future development of renewable energy projects.

The County Land Use Ordinance, Division 17, includes the RE Overlay Zone, which authorizes the development and operation of renewable energy projects with an approved CUP. The RE Overlay Zone is concentrated in areas determined to be the most suitable for the development of renewable energy facilities while minimizing the impact on other established uses. CUP applications proposed for specific renewable energy projects not located in the RE Overlay Zone would not be allowed without an amendment to the RE Overlay Zone.

As shown on Figure 2-1, the project site is located within the RE Overlay Zone. Therefore, no General Plan Amendment or Rezone would be required to implement the proposed project.

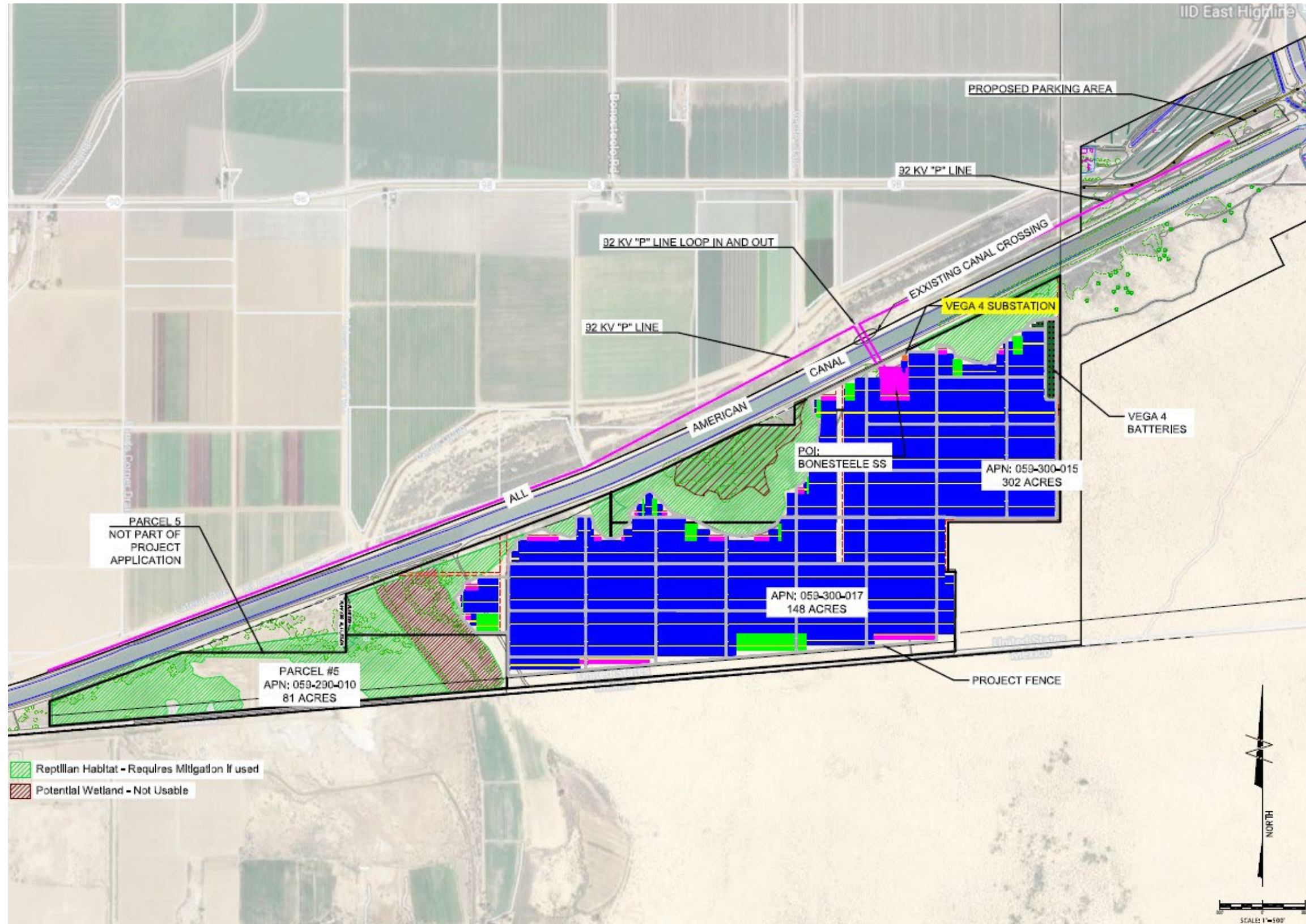
2.2 Project Objectives

- Construct and operate a solar energy facility capable of producing up to 100-megawatt (MW) alternating current (AC) of electricity to assist the State of California in achieving its 60 percent renewable portfolio standard by 2030.
- Provide a 100 MW energy BESS, that would accommodate and store the power generated by the project so that the facility can continue to provide renewable energy during non-daylight hours.
- Interconnect directly to IID's existing electrical transmission system.
- Help California meet its statutory and regulatory goal of increasing renewable power generation, including greenhouse gas reduction goals of Senate Bill 32.
- Minimize and mitigate any potential impact to sensitive environmental resources within the project area.

2.3 Project Characteristics

The proposed project involves the construction and operation of a 100 MW AC PV solar energy facility with an integrated 100 MW BESS (not to exceed 200 MW) on approximately 450 acres of land. As shown in Figure 2-3, the project site would be developed with a ground mounted PV solar power generating system, supporting structures, on-site substation, BESS, interconnection facilities, and internal access roads. The project would employ the use of PV power systems to convert solar energy into electricity using non-reflective technology.

Figure 2-3. Site Plan



This page is intentionally blank.

2.3.1 Photovoltaic Panels/Solar Arrays

PV solar cells convert sunlight directly into direct current electricity. The process of converting light (photons) to electricity (voltage) in a solid-state process is called the photovoltaic effect. A number of individual PV cells are electrically arranged and connected into solar PV modules, sometimes referred to as solar panels.

The project proposes to utilize either thin film or crystalline solar photovoltaic (PV) technology modules mounted either on fixed frames or horizontal single-axis tracker (HSAT) systems.

The fixed frame PV module arrays would be mounted on racks that would be supported by driven piles. The depth of the piles would be dependent on the recommendations of the geotechnical report prepared for the project. The fixed-frame racks would be secured at a fixed tilt of 20-30 degrees from horizontal facing a southerly direction. Current project designs would have individual PV modules, mounted two high on a fixed frame, providing a two-foot ground clearance and resulting in the tops of the panels at approximately 7.5 feet above the ground. The fixed PV modules would be arranged in arrays spaced approximately 15 to 25 feet apart (pile-to-pile) to maximize performance and to allow access for panel cleaning. These arrays would be separated from each other and the perimeter security fence by up to 30-foot-wide interior roads.

If HSAT technology is used, the PV modules would rotate around the north-south HSAT axis so that the PV modules would continue to face the sun as the sun moves across the sky throughout the day. The PV modules would reach their maximum height (up to 9 feet above the ground, depending on the final design) at both sunrise and sunset, when the HSAT is rotated to point the modules at the rising or setting sun. At noon, or when stowed during high winds, when the HSAT system is rotated so that the PV modules are horizontal, the nominal height would be about 6 feet above the ground, depending on the final design.

The individual PV systems would be arranged in large arrays by placing them in columns spaced approximately 10 feet apart to maximize operational performance and to allow access for panel cleaning and maintenance. Current project designs would have individual HSAT PV modules, each approximately two feet wide by four feet long (depending on the specific PV technology selected), mounted on a frame which is attached to an HSAT system. The HSAT arrays would be separated from each other and the perimeter security fence by up to 30-foot-wide roads, consistent with Imperial County Fire Department emergency access requirements.

2.3.2 Electrical Power System

Electricity generated by the PV modules would be collected by a direct current (DC) collection system routed underground in trenches. This DC power would be delivered to one of the pad-mounted inverters in weatherproof enclosures located within the arrays. The inverters would convert the DC power to three-phase alternating current (AC). The inverters could be connected to AC interconnection facilities which, if needed, would raise the voltage to 34.5 kilovolt (kV), or the interconnection voltage selected by the project. Underground or overhead 12.5 kV or 34.5 kV collection lines would transmit the electricity to the new project substation.

2.3.3 Interconnection Facilities

A new substation would be constructed on approximately two acres on the north-central portion of the project site. The substation would take the 34.5 kV power from the project and increase the voltage of

the electricity to 92 kV, where it would feed into the interconnection switching station for metering and delivery to the IID 92 kV “P” Line. The substation would include a transformer, circuit breakers, disconnect switches, and microwave or other communication facilities.

A new interconnection switching station would be constructed on the north-central portion of the project site, immediately adjacent to the substation. The switching station would include circuit breakers, switches, overhead bus work, protective relay equipment and an electrical control building. The switching station would operate at 92 kV and be equipped with two circuit breakers, allowing for looping in of the IID 92 kV “P” transmission line as well as connection to the project’s gen-tie line. The substation and switching station would be connected via a single overhead 92 kV line. The switching station would be enclosed within its own fence.

To connect the project’s interconnection facilities, the medium voltage power produced by the project would be conveyed underground, or above ground where necessary, to cross over any sensitive site features. The design of the project’s interconnection facilities would meet all necessary utility standards and requirements. As required, surge arrestors would be used to protect facilities and auxiliary equipment from lightning strikes or other disturbances. Distribution from the site would be via an overhead connection.

2.3.4 Gen-Tie

The electrical energy produced by the project would be conducted through the project’s interconnection facilities to the proposed 92 kV generator intertie (gen-tie) line and delivered to the existing IID approved POI on the 92 kV “P” Line. As shown in Figure 2-3, the project’s proposed 92 kV gen-tie would extend across the All-American Canal from the proposed project substation to the existing IID 92 kV “P” Line located immediately north of the canal. The height of the proposed gen-tie transmission structures would be 60 feet. The A-3 zone allows a maximum height limit of 120 feet for non-residential structures.

2.3.5 Battery Energy Storage System

The proposed BESS is proposed on approximately two acres on the northeast portion of the project site. The BESS would have a storage capacity of 100 MW (not exceed 200 MW). The BESS would consist of either lithium ion or flow batteries. The batteries will either be housed in storage containers or buildings fitted with HVAC and fire suppression systems as necessary, depending on the final selection of battery technology. Inside the housing the batteries will be placed on racks, the orientation of which depends on the type of housing. Underground trenches with conduits will be used to connect the batteries to the control and monitoring systems, and inverters to convert the PV produced DC power to AC power.

2.3.6 Security

Six-foot high security fencing would be installed around the perimeter of the project site at the commencement of construction and site access would be limited to authorized site workers. The project fence on the south would be setback a minimum of 180 feet from the U.S./Mexico international border. A motion detection system and closed-circuit camera system may also be installed. The site would be remotely monitored 24 hours per day, 7 days per week. In addition, routine unscheduled security rounds may be made by the security team monitoring the site security.

2.3.7 Site Access

The project site would be accessed via the following:

- **Worker Access:** Workers would utilize an existing driveway off State Route 98, park their vehicles in a designated staging/parking area north of the All-American Canal, and then walk across the All-American Canal at an existing crossing east of the project site (Figure 2-4 and Figure 2-5). No vehicles or construction vehicles are allowed to travel across this existing crossing. Designated shuttles would pick up workers at the south end of the crossing, and then travel west for approximately one mile along an existing dirt road to the project site.
- **Heavy Construction Equipment Access:** Vendors and heavy construction equipment would exit south from Interstate 8 onto Gordon Wells Road approximately 20 miles east of the project site, then travel west along an existing dirt road paralleling the U.S./Mexico Border (Figure 2-6). See Section 2.4.2 for a detailed description of this access route for heavy construction equipment. The applicant has entered into a Memorandum of Understanding with the U.S. Border Patrol setting forth the project-related activities that may occur on this existing dirt road used by the U.S. Border Patrol (see Section 2.7.3 for a detailed discussion).

The project driveways would be provided with a minimum of 30-foot double swing gates with “Knox Box” for keyed entry. Emergency response personnel would be provided with manual override capability in order to access the site facility.

To accommodate emergency access, PV panels would be spaced to maintain proper clearance. Internal access roads, up to 30-foot wide, would be constructed along the perimeter fence and solar panels to facilitate vehicle access and maneuverability for emergency unit vehicles.

2.3.8 Fire Protection/Fire Suppression

Fire protection systems for battery systems would be designed in accordance with California Fire Code and would take into consideration the recommendations of the National Fire Protection Association (NFPA) 855.

Fire suppression agents such as Novec 1230 or FM 2000, or water may be used as a suppressant. In addition, fire prevention methods would be implemented to reduce potential fire risk, including voltage, current, and temperature alarms. Energy storage equipment would comply with Underwriters Laboratory (UL)-95401 and test methods associated with UL-9540A. The project would include lithium-ion batteries. For lithium-ion batteries storage, a system would be used that would contain the fire event and encourage suppression through cooling, isolation, and containment. Suppressing a lithium-ion (secondary) battery is best accomplished by cooling the burning material. A gaseous fire suppressant agent (e.g., 3M™ Novec™ 1230 Fire Protection Fluid or similar) and an automatic fire extinguishing system with sound and light alarms would be used for lithium-ion batteries.

To mitigate potential hazards, redundant separate methods of failure detection would be implemented. These would include alarms from the Battery Management System (BMS), including voltage, current, and temperature alarms. Detection methods for off gas detection would be implemented, as applicable. These are in addition to other potential protective measures such as ventilation, overcurrent protection, battery controls maintaining batteries within designated parameters, temperature and humidity controls, smoke detection, and maintenance in accordance with manufacturer guidelines. Remote alarms would be installed for operations personnel as well as emergency response teams in addition to exterior hazard lighting. In addition, an Incidence Response Plan would be implemented. Additionally, the project applicant would contribute its proportionate share

for purchase of any fire-suppression equipment, if determined warranted by the County fire department for the proposed project.

2.4 Site Construction

2.4.1 Construction Activities

Construction activities would primarily involve demolition and grubbing, grading of the project site to establish access roads and pads for electrical equipment, trenching for underground electrical collection lines, and the installation of solar equipment and security fencing. Construction is estimated to take 12-18 months and would begin in late 2022 or 2023.

Dust generated during construction would be controlled by watering and, as necessary, the use of other dust suppression methods and materials accepted by the Imperial County Air Pollution Control District (ICAPCD).

A temporary, portable construction supply container would be located at the project site at the beginning of construction and removed at the end of construction.

The number of on-site construction workers for the solar facility is not expected to exceed 150 workers at any time. The number of on-site construction workers for the BESS and substation is not expected to exceed 100 workers at any one time. Onsite parking would be provided for all construction workers.

2.4.2 Heavy Construction Equipment Access

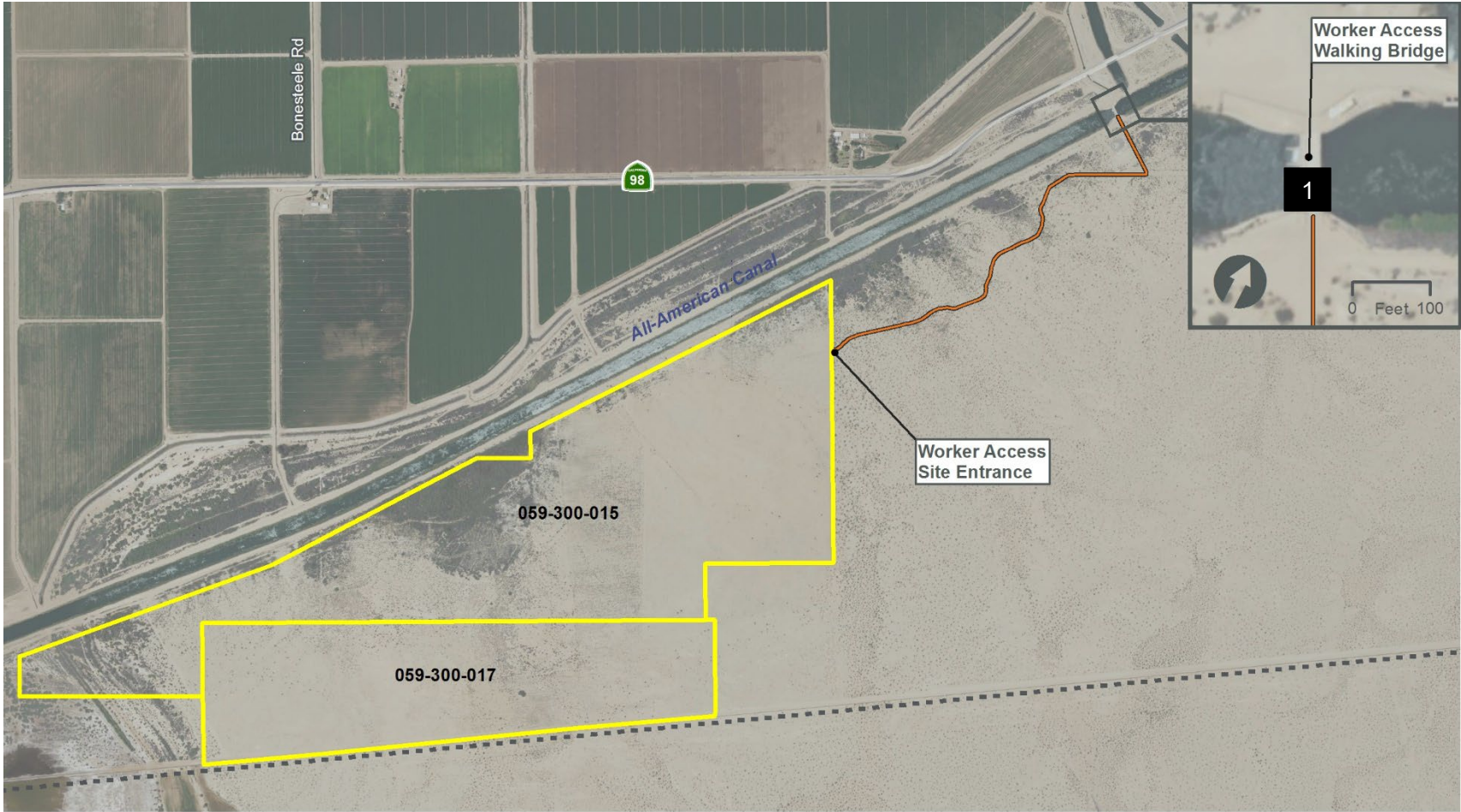
Following discussions with the IID, it was determined heavy construction vehicles would cross the All-American Canal at Gordon Wells Road located approximately 20 miles east of the project site (Figure 2-6). Access for heavy construction vehicles to and from the project site requires crossing the All-American Canal, via two existing bridges (Figure 2-7), located along Gordon Wells Road. Gordon Wells Road has an interchange with I-8. The bridges over the canal were constructed in 2009. The bridges are rated as open with no restrictions and have a “Good” condition rating.

An estimated two trucks would arrive at the project site each day during the first few weeks of construction of the solar facility.

2.4.3 Parking and Staging Areas

As described above, workers would utilize an existing driveway off State Route 98 (Figure 2-4) and then park their vehicles in a designated staging/parking area, approximately 3.5 acres in size, north of the All-American Canal (Figure 2-3). The staging/parking area will need to be improved to facilitate access and minimize parking conflicts. Dust would be controlled by watering and, as necessary, the use of other dust suppression methods and materials accepted by the ICAPCD.

Figure 2-4. Construction Worker Access



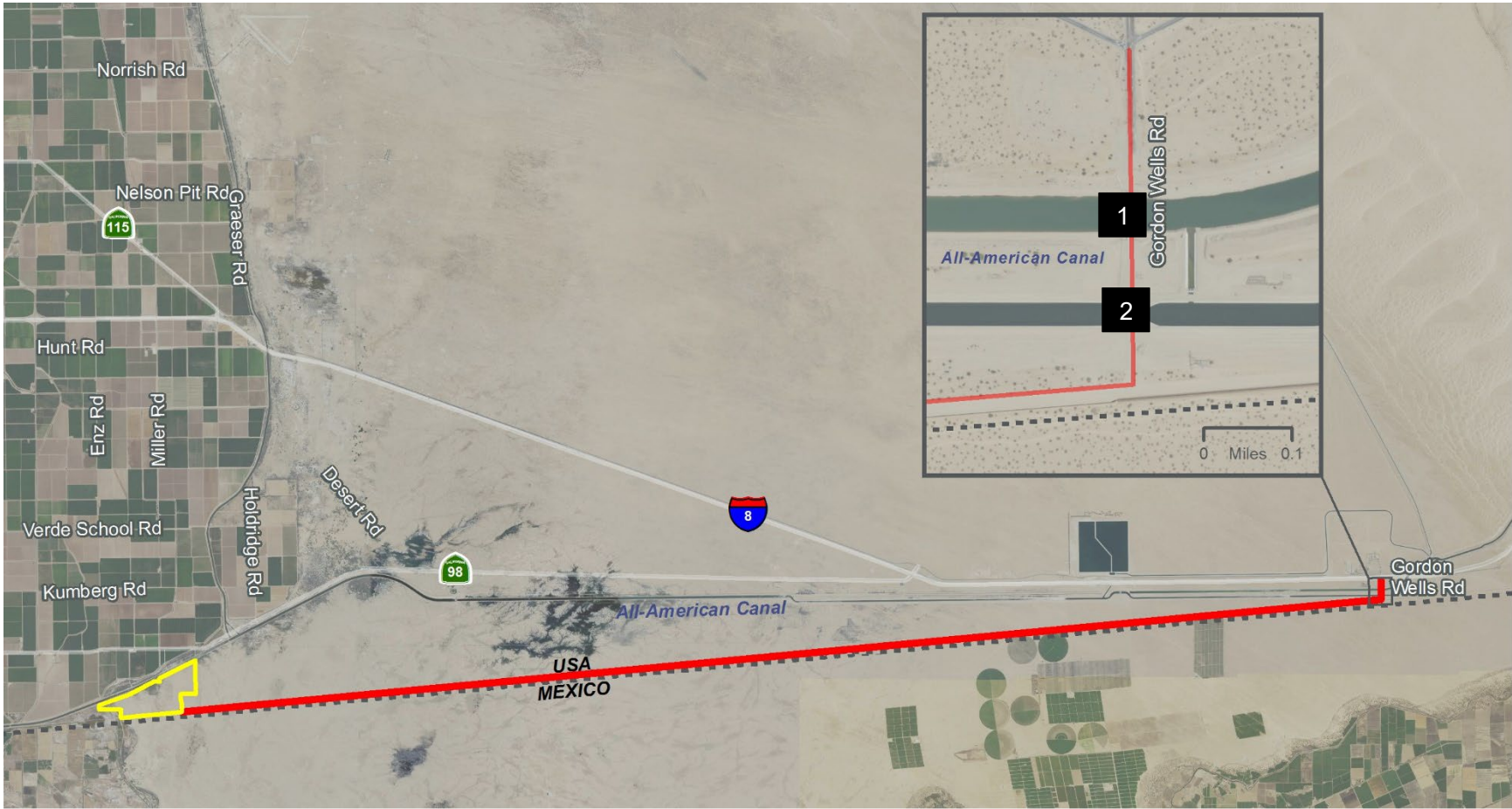
- Legend
- Project Area
 - Proposed Worker Access Road
 - Bridge Crossing Location – see Figure 2-5 for photo






Figure 2-5. Bridge Crossing – Pedestrian Access Only



Figure 2-6. Proposed Heavy Construction Equipment Access



Legend

-  Proposed Heavy Construction Equipment Access
-  Project Location
-  # Bridge Crossing Locations – see Figure 2-7 for photos



This page is intentionally blank.

Figure 2-7. Proposed Bridge Crossings over All-American Canal



Bridge over north American Canal



Bridge over south American Canal

2.4.4 Water Use

Water for construction, primarily for dust control, would be obtained from local IID irrigation canals or laterals in conformance with IID rules and regulations for municipal, commercial, and industrial (MCI) temporary water use. Water would be picked up from the All-American Canal and delivered to the construction location by a water truck which would be capable of carrying approximately 4,000 gallons per load. It is estimated that up to 183 acre-feet of water would be needed for site grading and dust control over the expected construction period.

2.5 Operations and Maintenance

Once construction is completed, the facility would be remotely operated, controlled and monitored and with no requirement for daily on-site employees. Security personnel may conduct unscheduled security rounds and would be dispatched to the project site in response to a fence breach or other alarm.

Up to two to three people would be contracted (part-time) to perform all routine and emergency operational and maintenance activities. Such activities include inspections, equipment servicing, site and landscape clearing, and periodic washing of the PV modules if needed (up to two times per year) to maintain power generation efficiency. The amount of water needed for solar panel washing is estimated at approximately 5 AF per washing, with up to two washings per year, or a total of up to 10 AF per year. Vegetation growing on the solar energy facility site would periodically (approximately every 3 months) be removed manually and/or treated with herbicides.

Operation of the proposed project would require upgrades including but not limited to relay upgrades, Phasor Measurement Unit Requirements, Relay, SCADA, Metering and Telecom upgrades at the Ramon Substation located at 75800 Ramon Road, Thousand Palms, CA. The construction and operation of these upgrades by IID required to adequately operate the project are included as part of the project and project analysis.

2.5.1 Water Use

Water for washing the PV modules would be purchased from the IID and delivered to the project site by water trucks. The volume of water to be used for PV module washing and dust control is estimated at up to 10-acre feet per year.

2.6 Restoration of the Project Site

Electricity generated by the facility could be sold under the terms of a PPA with a power purchaser (i.e., utility service provider). At the end of the PPA term, the owner of the facility may choose to enter into a subsequent PPA, update technology and re-commission, or decommission and remove the generating facility and its components. Upon decommissioning, the site could be converted to other uses in accordance with applicable land use regulations in effect at that time. A collection and recycling program will be executed to promote recycling of project components and minimize disposal in landfills. All permits related to decommissioning would be obtained, where required.

Project decommissioning may include the following activities:

- The facility would be disconnected from the utility power grid.

- Project components would be dismantled and removed using conventional construction equipment and recycled or disposed of safely.
- PV panel support steel and support posts would be removed and recycled off-site by an approved metals recycler.
- All compacted surfaces within the project site and temporary on-site haul roads would be de-compacted.
- Electrical and electronic devices, including inverters, transformers, panels, support structures, lighting fixtures, and their protective shelters would be recycled off-site by an approved recycler.
- All concrete used for the underground distribution system would be recycled off-site by a concrete recycler or crushed on-site and used as fill material.
- Fencing would be removed and recycled off-site by an approved metals recycler.
- Gravel roads would be removed; filter fabric would be bundled and disposed of in accordance with all applicable regulations. Road areas would be backfilled and restored to their natural contour.
- Soil erosion and sedimentation control measures would be re-implemented during the decommissioning period and until the site is stabilized.

2.7 Required Project Approvals

2.7.1 Imperial County

The following are the primary discretionary approvals required for implementation of the project:

1. **Approval of CUP.** Implementation of the project would require the approval of a CUP by the County to allow for the construction and operation of the proposed solar energy facility with an integrated BESS. The project site is located on two privately-owned legal parcels zoned Heavy Agriculture with a Renewable Energy Zone Overlay (A-3-RE). Pursuant to Title 9, Division 5, Chapter 9, the following uses are permitted in the A-3 zone subject to approval of a CUP from Imperial County:
 - i) *Battery Storage Facility (must be connected to an existing electrical power generation plant such as solar, geothermal, wind, natural gas, or other renewable energy generator, as an accessory unit to said power plant).*
 - oo) *Major facilities relating to the generation and transmission of electrical energy, provided such facilities are not under State or Federal law, to [be] approved exclusively by an agency, or agencies of the State or Federal government, and provided such facilities shall be approved subsequent to coordination review of the Imperial Irrigation District for electrical matters, meeting the requirements in Division 17.*
 - zz) *Solar energy plants meeting the requirements in Division 17.*
2. **Certification of the EIR.** After the required public review for the Draft EIR, the County will respond to written comments, edit the document, and produce a Final EIR to be certified by the Planning Commission and Board of Supervisors prior to deciding on approval or denial of the project.

Subsequent ministerial approvals may include, but are not limited to:

- Grading and clearing permits
- Building permits
- Reclamation plan
- Encroachment permits
- Transportation permit(s)

2.7.2 Discretionary Actions and Approvals by Other Agencies

Responsible Agencies are those agencies that have discretionary approval over one or more actions involved with development of the project. Trustee Agencies are state agencies that have discretionary approval or jurisdiction by law over natural resources affected by a project. These agencies may include, but are not limited to the following:

- California RWQCB – Notice of Intent for General Construction Permit, CWA 401 Water Quality Certification
- ICAPCD – Fugitive Dust Control Plan, Rule 801 Compliance
- CDFW (Trustee Agency) – ESA Compliance, Section 1600 Streambed Alteration Agreement
- USFWS – ESA Compliance
- USACE – Section 404 of the CWA Permit
- IID – Water Supply Agreement

2.7.3 Memorandum of Understanding – U.S. Border Patrol

The project applicant and U.S. Border Patrol (USBP) will develop and enter into a Memorandum of Understanding (MOU) setting forth the project-related activities that may occur on an existing dirt road used by the USBP.

- Project applicant will provide an additional 60 feet of right-of-way along its southern end of the property to allow for additional protective area for the U.S. Border Patrol Services functions.
- Project applicant will install a 6-foot-high chain link fence with barb wire on top surrounding the project site.
- Project applicant will provide a mechanism acceptable to USBP for access to the site upon completion of the construction in the event USBP needs to enter for enforcement purposes.
- Project applicant will provide full-time security during construction of the project and will coordinate with USBP on this service.
- Project applicant will provide contact information for both construction phases and operation phases to make sure USBP has direct contact information.
- Project applicant will maintain the road between the site and its terminus at the I-8/HWY 98 intersection during the construction of the site in a manner prescribed by USBP. At a minimum this will be routine watering and as necessary grading. No material will be added to the road

without approval from USBP. Additionally, no work will be done adjacent to the road that would interfere with USBP's 'brushing' program.

- Project applicant will have an agreement with US BREC for the pedestrian traffic crossing at the IID drop and will observe USBP protocols for all people crossing for the project both during construction and future operations.
- Project applicant will notify the USBP's designated representative prior to any use of the road from Gordons Well access to the site.
- USBP will immediately contact designated project representatives if they encounter a problem at the site in an effort to give project applicant an opportunity to cure.

This page is intentionally blank.

3 Environmental Analysis, Impacts, and Mitigation

3.1 Introduction to Environmental Analysis

This section provides an overview of the environmental analysis and presents the format for the environmental analysis in each topical section.

3.1.1 Organization of Issue Areas

Chapter 3 provides an analysis of impacts for those environmental topics that the County determined could result in “significant impacts,” based on preparation of an Initial Study and review by the County’s Environmental Evaluation Committee and responses received during the scoping process, including the NOP review period and public scoping meeting. Sections 3.2 through 3.15 discuss the environmental impacts that may result with approval and implementation of the project, and where impacts are identified, recommends mitigation measures that, when implemented, would reduce significant impacts to a level less than significant. Each environmental issue area in Chapter 3 contains a description of the following:

- The environmental setting as it relates to the specific issue
- The regulatory framework governing that issue
- The threshold of significance (from Appendix G of the CEQA Guidelines)
- The methodology used in identifying and considering the issues
- An evaluation of the project-specific impacts and identification of mitigation measures
- A determination of the level of significance after mitigation measures are implemented
- The identification of any residual significant impacts following mitigation

3.1.2 Format of the Impact Analysis

This analysis presents the potential impacts that could occur under the project along with any supporting mitigation requirements. Each section identifies the resulting level of significance of the impact using the terminology described below following the application of the proposed mitigation. The section includes an explanation of how the mitigation measure(s) reduces the impact in relation to the applied threshold of significance. If the impact remains significant (i.e., at or above the threshold of significance), additional discussion is provided to disclose the implications of the residual impact and indicate why no mitigation is available or why the applied mitigation does not reduce the impact to a less than significant level.

Changes that would result from the project were evaluated relative to existing environmental conditions within the project site as defined in Chapter 2 and illustrated on Figure 2-2 (Chapter 2). Existing environmental conditions are based on the time at which the NOP was published on May 4, 2021. In evaluating the significance of these changes, this EIR applies thresholds of significance that have been developed using: (1) criteria discussed in the CEQA Guidelines; (2) criteria based on factual or

scientific information; and (3) criteria based on regulatory standards of local, state, and/or federal agencies. Mechanisms that could cause impacts are discussed for each issue area.

This EIR uses the following terminology to denote the significance of environmental impacts of the project:

- *No impact* indicates that the construction, operation, and maintenance of the project would not have any direct or indirect effects on the environment. It means no change from existing conditions. This impact level does not need mitigation.
- A *less than significant impact* is one that would not result in a substantial or potentially substantial adverse change in the physical environment. This impact level does not require mitigation, even if feasible, under CEQA.
- A *significant impact* is defined by CEQA Section 21068 as one that would cause “a substantial, or potentially substantial, adverse change in any of the physical conditions within the area affected by the project.” Levels of significance can vary by project, based on the change in the existing physical condition. Under CEQA, mitigation measures or alternatives to the project must be provided, where feasible, to reduce the magnitude of significant impacts.
- An *unmitigable significant impact* is one that would result in a substantial or potentially substantial adverse effect on the environment, and that could not be reduced to a less than significant level even with any feasible mitigation. Under CEQA, a project with significant and unmitigable impacts could proceed, but the lead agency would be required to prepare a “statement of overriding considerations” in accordance with State CEQA Guidelines California Code of Regulations (CCR) Section 15093, explaining why the lead agency would proceed with the project in spite of the potential for significant impacts.

3.2 Aesthetics and Visual Resources

This section provides a description of the existing visual and aesthetic resources within the project area and relevant state and local plans and policies regarding the protection of scenic resources. Effects to the existing visual character of the project area as a result of project-related facilities are considered and mitigation is proposed based on the anticipated level of significance. The information provided in this section is summarized from the *Visual Impact Assessment Letter Report – VEGA SES 4 Project* (Appendix B of this EIR) prepared by ECORP Consulting, Inc.

3.2.1 Existing Conditions

The project site is located in south-central Imperial County. The irregular shaped project site is bound by undeveloped land, portions of which have been disturbed associated with previous agricultural-related activities to the west and east, the All-American Canal running southwest on the northern border of the project site, and the U.S./Mexico international border to the south. The topography of the project site is relatively flat with elevations ranging between 38 feet and 60 feet) above mean sea level. The majority of the project site consists of creosote bush scrub, alkali weed, and disturbed land.

Scenic Vista

Scenic vistas are typically expansive views from elevated areas. They may or may not be part of a designated scenic overlook or other area providing a static vista view of a landscape. The project site is located in a rural portion of Imperial County and is not located within an area containing a scenic vista designated by the State or the County's General Plan.

Scenic Highways

According to the Conservation and Open Space Element, no State scenic highways have been designated in Imperial County (County of Imperial 2016). The project site is not located within a State scenic highway corridor, nor are there any State scenic highways located in proximity to the project site. The nearest road segment considered eligible for a State scenic highway designation is Interstate 8, located over five miles northwest of the project site.

Visual Character

Available public right of way in the vicinity of the project site includes SR-98 and Vencil Road. Visibility of the project site from the public right of way is obstructed from SR-98 by a berm. Visibility of the project site from Vencil Road is limited due to a distance of approximately 0.5 mile. Surrounding property is privately owned and viewers would be limited to property owners, employees servicing/maintaining IID facilities (e.g., the canal), and border patrol personnel.

Light, Glare, and Glint

Glare is considered a continuous source of brightness, relative to diffused light, whereas glint is a direct redirection of the sun beam in the surface of a PV solar module. Glint is highly directional, since its origin is purely reflective, whereas glare is the reflection of diffuse irradiance; it is not a direct reflection of the sun.

The project site is currently vacant and due to its rural location does not generate any light or glare under existing conditions.

3.2.2 Regulatory Setting

This section identifies and summarizes laws, policies, and regulations that are applicable to the project.

State

California Department of Transportation

Caltrans manages the California Scenic Highway Program. The goal of the program is to preserve and protect scenic highway corridors from changes that would affect the aesthetic value of the land adjacent to the scenic corridor.

Local

Imperial County General Plan

The Imperial County General Plan contains policies for the protection and conservation of scenic resources and open spaces within the County. These policies also provide guidance for the design of new development. The Conservation and Open Space Element of the General Plan provides specific goals and objectives for maintaining and protecting the aesthetic character of the region. Table 3.2-1 provides an analysis of the project’s consistency with the Conservation and Open Space Element Goal 5. Additionally, the Circulation and Scenic Highways Element of the General Plan provides policies for protecting and enhancing scenic resources within highway corridors in Imperial County, consistent with the Caltrans State Scenic Highway Program.

County of Imperial Land Use Ordinance, Title 9

The County’s Land Use Ordinance Code provides specific direction for lighting requirements.

Division 17: Renewable Energy Resources, Section 91702.00 – Specific Standards for All Renewable Energy Projects

- (R) Lights should be directed or shielded to confine direct rays to the Project site and muted to the maximum extent consistent with safety and operational necessity.

Table 3.2-1. Consistency with Applicable General Plan Conservation and Open Space Policies

General Plan Policies	Consistency with General Plan	Analysis
Goal 5: The aesthetic character of the region shall be protected and enhanced to provide a pleasing environment for residential, commercial, recreational, and tourist activity.	Consistent	As described in Section 3.2.3, the proposed project would result in changes to the existing visual character of the project site. However, public views of the project site are limited, and the proposed project would not result in a significant deterioration in the visual character of the project site or surrounding area from public viewpoints.

Table 3.2-1. Consistency with Applicable General Plan Conservation and Open Space Policies

General Plan Policies	Consistency with General Plan	Analysis
Objective 5.1: Encourage the conservation and enhancement of the natural beauty of the desert and mountain landscape.	Consistent	The project site is located on rural agricultural land located in Imperial County. The irregular shaped project site is bound by undeveloped land, portions of which have been disturbed associated with previous agricultural-related activities to the west and east, the All-American Canal running southwest on the northern border of the project site, and the U.S./Mexico international border to the south. The project site is currently characterized by flat and undeveloped land, portions of which have been disturbed associated with previous agricultural-related activities. Development of the project site would not impact the desert and mountain landscapes common in Imperial County.

Source: County of Imperial 2016

3.2.3 Impacts and Mitigation Measures

Thresholds of Significance

Based on CEQA Guidelines Appendix G, project impacts related to aesthetics are considered significant if any of the following occur:

- Have a substantial adverse effect on a scenic vista
- Substantially damage scenic resources, including, but not limited to, trees, rock outcroppings, and historic buildings within a state scenic highway
- In non-urbanized areas, substantially degrade the existing visual character or quality of public views of the site and its surroundings? (Public views are those that are experienced from publicly accessible vantage points). If the project is in an urbanized area, would the project conflict with applicable zoning and other regulations governing scenic quality
- Create a new source of substantial light or glare which would adversely affect day or nighttime views in the area

Methodology

Due to the rural nature of the project site, the evaluation of potential visual impacts resulting from implementation of the proposed project was based on the following qualitative criteria:

- **Changes in Visual Quality.** The difference in visual quality between the existing environmental setting and post-project condition is considered visual quality change. Changes in visual quality were identified by studying engineering plans, which provide information on the various elements that would be added to the current viewshed and the degree of change in the existing visual setting.

- **Impacts to Visual Resources.** Visual resources from both the natural and built environments can enhance the visual character and aesthetic quality of an area. Visual resources can be associated with local events and history that represent and enhance the visual character of the local area. The project site and vicinity were studied for visual resources. A project that substantially alters important visual resources can result in adverse visual impacts. Mitigation is typically implemented to remove or minimize adverse visual impacts.
- **Light, Glare, Shade, and Shadow.** The existing light environment serves as a baseline to conduct light analysis and compare potential impacts caused by introduction of one of the alternatives. Impacts relating to light, glare, shade, and shadow were examined during field observations and photographs to help establish light conditions during various times of the day and night and to estimate the potential changes in the environment from project implementation. Impacts were evaluated based on how much the existing conditions change, the degree of those changes, and the sensitivity of the affected environment.
- **Compatibility with Visual Policies.** General plans, specific plans, and other regulations or policies relating to visual resources and setting at the project site were identified and reviewed, to assess the project's compatibility with applicable policies.

Impact Analysis

Impact 3.2-1 Would the project have a substantial adverse effect on a scenic vista?

There are no designated scenic vistas in the project vicinity. The proposed project would involve the use of standard construction equipment including, but limited to, trucks, cranes, and tractors. The presence of this equipment within the project area during construction would alter views of the area from undeveloped land to a construction site. However, the views of construction activity from the surrounding vicinity would be temporary and would not involve any designated scenic vistas. Therefore, impacts to a scenic vista are considered less than significant during construction.

Upon project operation, and with implementation of the solar infrastructure, the overall visual character of the project site would change. However, given that there are no scenic resources or vistas within proximity to the project site, project operation would not have a substantial adverse effect on a scenic vista. Impacts are considered less than significant.

Mitigation Measure(s)

No mitigation measures are required.

Impact 3.2-2 Would the project substantially damage scenic resources, including, but not limited to, trees, rock outcroppings, and historic buildings within a state scenic highway?

According to the Conservation and Open Space Element, no State scenic highways have been designated in Imperial County (County of Imperial 2016). The project site is not located within a State scenic highway corridor, nor are there any State scenic highways located in proximity to the project site. The nearest road segment considered eligible for a State scenic highway designation is Interstate 8, located over five miles northwest of the project site. Therefore, no impacts to scenic resources within a designated state scenic highway would occur.

Mitigation Measure(s)

No mitigation measures are required.

Impact 3.2-3 In non-urbanized areas, would the project substantially degrade the existing visual character or quality of public views of the site and its surroundings? (Public views are those that are experienced from publicly accessible vantage points). If the project is in an urbanized area, would the project conflict with applicable zoning and other regulations governing scenic quality?

The project site is located on a vacant site in rural Imperial County. Visibility of the project site from the public right of way is obstructed from SR-98 by a berm. Visibility of the project site from Vencil Road is limited due to a distance of approximately 0.5 mile. Surrounding property is privately owned and viewers would be limited to private property owners, employees servicing/maintaining IID facilities (e.g., the canal), and border patrol personnel.

Specifically, and as stated above in Impact 3.2-1, construction of the project would result in temporary visual changes due to the presence of construction equipment, materials, and construction activities. However, visual impacts during project construction would be short-term. Upon completion of construction, equipment and construction materials would no longer be present on-site. Therefore, project construction would not substantially degrade the existing visual character or quality of public views of the site and its surroundings.

Project operation would change the visual character of the project site by altering the natural conditions of the site to a solar energy generation and battery storage facility. The main physical change that would occur is the complete removal of vegetation and grading of the project site to accommodate the construction of solar apparatus and security fencing. While the proposed PV module frames would be approximately 7.5 feet in height and the proposed security fencing would be approximately 6 feet in height, views of the project site are limited from public viewpoints, and, as such, the addition of solar infrastructure to the project site would not substantially degrade the existing visual character or quality of public views of the site and its surroundings. Other facilities proposed such as roads, pads, underground utilities, and stormwater facilities would not be readily visible from public viewpoints as these facilities would be at or below grade.

Based on the above evaluation, the project would not substantially degrade the existing visual character or quality of public views of the site and its surroundings or conflict with applicable zoning. Impacts are considered less than significant.

Mitigation Measure(s)

No mitigation measures are required.

Impact 3.2-4 Would the project create a new source of substantial light or glare which would adversely affect day or nighttime views in the area?

As described in Chapter 2, Project Description, the project would include new sources of nighttime lighting. In addition, given the nature of the project (e.g., solar facility), this discussion also considers potential glare- and glint-related impacts generated by the proposed solar arrays. This discussion considers each issue under the associated headings below.

NIGHTTIME LIGHTING

Project construction may result in slight increases in nighttime lighting onsite if nighttime construction is warranted. However, public views of the project site are limited and, as such, construction-related nighttime lighting is not anticipated to adversely affect nighttime views. Additionally, visual impacts associated with nighttime lighting during project construction would be short-term. Upon completion of construction, equipment and construction materials would no longer be present on-site. Therefore, this is considered a less than significant impact.

Minimal lighting would be required for project operation and would be limited to safety and security functions. All lighting would be directed downward and shielded to confine direct rays to the project site and muted to the maximum extent consistent with safety and operational necessity (Title 9, Division 17, Chapter 2: Specific Standards for all Renewable Energy Projects, of the County's Zoning Ordinance).

If additional lighting should be required for nighttime maintenance, portable lighting equipment would be used. Based on these considerations, and the distance to potential viewers, the project is not anticipated to create a new source of substantial light which would adversely affect nighttime views in the project area, and the impact is considered less than significant.

GLARE AND GLINT

Project construction may result in slight increases in glare and glint onsite due to the presence of reflective construction equipment and materials. However, public views of the project site are limited and, as such, construction-related glare and glint are not anticipated to adversely affect day or nighttime views. Additionally, visual impacts associated with light and glare during project construction would be short-term. Upon completion of construction, equipment and construction materials would no longer be present on-site. Therefore, this is considered a less than significant impact.

The project would involve the installation of PV solar arrays which have low reflectivity. Solar PV modules are specifically designed to reduce reflection as any reflected light cannot be converted into energy. Research has shown that reflectivity from PV panels is similar to reflections from water (Appendix B of this EIR). Therefore, upon operation, the PV panels would not create a significant source of glare during sunlight hours. Additionally, public views of the project site are limited and, as such, operation-related glare and glint, while minimal, are not anticipated to adversely affect day or nighttime views. The project would not use other reflective materials such as fiberglass, aluminum or vinyl/plastic siding, galvanized products, and brightly painted steel roofs that have the potential to create on- and off-site glare.

Shade and shadow effects would be introduced within the project site due to the placement of PV modules in arrays. However, due to the height of the proposed apparatus at 7.5 feet and the perimeter fencing at 6 feet, the effects of shade and shadow would not encroach into areas offsite for extended periods of time that would result in significant shade and/or shadow impacts. Therefore, the proposed project would not result in a significant glare impact to motorists driving on roadways adjacent to the project site.

Mitigation Measure(s)

No mitigation measures are required.

3.2.4 Decommissioning/Restoration and Residual Impacts

Decommissioning/Restoration

If at the end of the PPA term, no contract extension is available for a power purchaser, no other buyer of the energy emerges, or there is no further funding of the project, the project will be decommissioned and dismantled. The project site is relatively flat and primarily characterized by a level elevation. Therefore, no grading or significant landform modifications would be required during decommissioning activities upon site restoration in the future. Although the project site would be visually disrupted in the short-term during decommissioning activities, because extensive grading is not required and these activities would be temporary, the visual character of the project site would not be substantially degraded in the short-term and related impacts would be less than significant.

Residual

Impacts related to glare and glint impacts to roadway travelers would be less than significant and no additional mitigation measures are required. Changes to visual character of the project area would be less than significant and would be transitioned back to their prior (pre-solar project) conditions following site decommissioning. Based on these conclusions, implementation of the project would not result in residual significant unmitigable impacts to the visual character of the project area or add substantial amounts of light and glare.

This page is intentionally blank.

3.3 Agricultural Resources

This section provides an overview of existing agricultural resources within the project site and identifies applicable federal, state, and local policies related to the conservation of agricultural lands. This includes a summary of the production outputs, soil resources, and adjacent operations potentially affected by the project. The impact assessment in Section 3.3.3 provides an evaluation of potential adverse effects on agricultural resources based on criteria derived from the CEQA Guidelines in conjunction with actions proposed in Chapter 2, Project Description. Section 3.3.4 provides a discussion of residual impacts, if any.

No forestry resources are present within the project site and, therefore, this section focuses on issues related to agricultural resources.

3.3.1 Existing Conditions

Agriculture has been the single most important economic activity of Imperial County throughout the 20th century and is expected to play a major economic role in the foreseeable future. The gross annual value of agricultural production in the County has hovered around \$1 billion for the last several years, making it the County's largest source of income and employment.

Imperial County agriculture is a major producer and supplier of high-quality plant and animal foods and non-food products. In 2019, agriculture contributed a total of \$2.01 billion to the county economy. Vegetable and melon crops were the single largest production category by dollar value (\$799 million). Livestock represented the second largest category (\$522 million) and consisted mostly of feedlot cattle (\$449 million). Field crops ranked third with \$498 million (Imperial County Agricultural Commissioner 2019).

Important Farmland

According to the California Department of Conservation's (DOC) California Important Farmland Finder, the majority of the project site is designated as Other Land (DOC 2021). A portion of the project site is designated as Farmland of Local Importance. Farmland of Local Importance is not considered an "agricultural land" per CEQA Statute Section 21060.1(a). The project site does not contain Prime Farmland, Farmland of Statewide Importance, or Unique Farmland. No portion of the project site is currently being utilized for agricultural production and has remained in a fallow state for a period of time (exceeding five years).

Williamson Act Contract Land

According to the 2016/2017 Imperial County Williamson Act Map produced by the DOC, the project site is not located on Williamson Act contracted land (DOC 2016).

3.3.2 Regulatory Setting

This section identifies and summarizes state and local laws, policies, and regulations that are applicable to the project.

State

California Land Conservation Act

The Williamson Act (California Land Conservation Act, California Government Code, Section 51200 et seq.) is a statewide mechanism for the preservation of agricultural land and open space land. The Act provides a comprehensive method for local governments to protect farmland and open space by allowing land in agricultural use to be placed under contract (agricultural preserve) between a local government and a landowner.

Under the provisions of the Williamson Act (California Land Conservation Act 1965, Section 51200), landowners contract with the County to maintain agricultural or open space use of their lands in return for reduced property tax assessment. The contract is self-renewing and the landowner may notify the County at any time of intent to withdraw the land from its preserve status. Withdrawal involves a 10-year period of tax adjustment to full market value before protected open space can be converted to urban uses. Consequently, land under a Williamson Act Contract can be in either a renewal status or a nonrenewable status. Lands with a nonrenewable status indicate the farmer has withdrawn from the Williamson Act Contract and is waiting for a period of tax adjustment for the land to reach its full market value. Nonrenewable and cancellation lands are candidates for potential urbanization within a period of 10 years.

The requirements necessary for cancellation of land conservation contracts are outlined in Government Code Section 51282. The County must document the justification for the cancellation through a set of findings. Unless the land is covered by a farmland security zone contract, the Williamson Act requires that local agencies make both the Consistency with the Williamson Act and Public Interest findings.

On February 23, 2010, the Imperial County Board of Supervisors voted to not accept any new Williamson Act contracts and not to renew existing contracts because of the elimination of the subvention funding from the state budget. The County reaffirmed this decision in a vote on October 12, 2010, and notices of nonrenewal were sent to landowners with Williamson Act contracts following that vote. The applicable deadlines for challenging the County's actions have expired, and, therefore, all Williamson Act contracts in Imperial County will terminate on or before December 31, 2018.

California Farmland Mapping and Monitoring Program

The California DOC, under the Division of Land Resource Protection, has set up the Farmland Mapping and Monitoring Program (FMMP), which monitors the conversion of the state's farmland to and from agricultural use. The map series identifies eight classifications, as defined below, and uses a minimum mapping unit size of 10 acres.

- Prime Farmland has the best combination of physical and chemical features able to sustain long-term agricultural production. This land has the soil quality, growing season, and moisture supply needed to produce sustained high yields. Land must have been used for irrigated agricultural production at some time during the 4 years prior to the mapping date.
- Farmland of Statewide Importance is similar to Prime Farmland but with minor shortcomings, such as greater slopes or less ability to store soil moisture. Land must have been used for irrigated agricultural production at some time during the 4 years prior to the mapping date.

- Unique Farmland consists of lesser quality soils used for the production of the state's leading agricultural crops. This land is usually irrigated but may include non-irrigated orchards or vineyards as found in some climatic zones in California. Land must have been cropped at some time during the 4 years prior to the mapping date.
- Farmland of Local Importance is land of importance to the local agricultural economy as determined by each county's board of supervisors and a local advisory committee.
- Grazing Land is land on which the existing vegetation is suited to the grazing of livestock. This category was developed in cooperation with the California Cattlemen's Association, University of California Cooperative Extension, and other groups interested in the extent of grazing activities.
- Urban and Built-up Land is occupied by structures with a building density of at least one unit to 1.5 acre, or approximately six structures to a 10-acre parcel. Common examples include residential, industrial, commercial, institutional facilities, prisons, cemeteries, airports, golf courses, sanitary landfills, sewage treatment, and water control structures.
- Water is defined as perennial water bodies with an extent of at least 40 acres.
- Other Land is land not included in any other mapping category. Common examples include low density rural developments, vegetative and riparian areas not suitable for livestock grazing, confined animal agriculture facilities, strip mines, borrow pits, and water bodies smaller than 40 acres. Vacant and nonagricultural land surrounded on all sides by urban development and greater than 40 acres is mapped as Other Land. More detailed data on these uses is available in counties containing the Rural Land Use Mapping categories.

The program also produces a biannual report on the amount of land converted from agricultural to non-agricultural use. The program maintains an inventory of state agricultural land and updates its "Important Farmland Series Maps" every 2 years. Table 3.3-1 provides a summary of agricultural land within Imperial County converted to non-agricultural uses during the time frame from 2016 to 2018.

Table 3.3-1. Imperial County Change in Agricultural Land Use Summary (2016 to 2018)

Land Use Category	Total Acreage Inventoried		2016 to 2018 Acreage Changes			
	2016	2018	Acres Lost (-)	Gained (+)	Total Acreage Changed	Net Acreage Changed
Prime Farmland	190,206	189,163	1,699	656	2,355	-1,043
Farmland of Statewide Importance	297,272	291,596	6,330	654	6,984	-5,676
Unique Farmland	2,071	1,905	190	24	214	-166
Farmland of Local Importance	38,923	39,711	1,587	2,375	3,962	788
Important Farmland Subtotal	528,472	522,375	9,806	3,709	13,515	-6,097
Grazing Land	0	0	0	0	0	0

Table 3.3-1. Imperial County Change in Agricultural Land Use Summary (2016 to 2018)

Land Use Category	Total Acreage Inventoried		2016 to 2018 Acreage Changes			
	2016	2018	Acres Lost (-)	Gained (+)	Total Acreage Changed	Net Acreage Changed
Agricultural Land Subtotal	528,472	522,375	9,806	3,709	13,515	-6,097
Urban and Built-Up Land	37,412	41,764	301	4,653	4,954	4,352
Other Land	461,891	463,488	712	2,309	3,021	1,597
Water Area	749	897	125	273	398	148
Total Area Inventoried	1,028,524	1,028,524	10,944	10,944	21,888	0

Source: DOC 2018

Local

County of Imperial General Plan

The Agricultural Element of the County’s General Plan serves as the primary policy statement for implementing development policies for agricultural land use in Imperial County. The goals, objectives, implementation programs, and policies found in the Agricultural Element provide direction for new development as well as government actions and programs. Imperial County’s Goals and Objectives are intended to serve as long-term principles and policy statements to guide agricultural use decision-making and uphold the community’s ideals.

Agriculture has been the single most important economic activity in the County throughout its history. The County recognizes the area as one of the finest agricultural areas in the world because of several environmental and cultural factors including good soils, a year-round growing season, the availability of adequate water transported from the Colorado River, extensive areas committed to agricultural production, a gently sloping topography, and a climate that is well-suited for growing crops and raising livestock. The Agricultural Element in the County General Plan demonstrates the long-term commitment by the County to the full promotion, management, use, and development and protection of agricultural production, while allowing logical, organized growth of urban areas (County of Imperial 2015).

The County’s Agricultural Element identifies several Implementation Programs and Policies for the preservation of agricultural resources. The Agricultural Element recognizes that the County can and should take additional steps to provide further protection for agricultural operations and at the same time provide for logical, organized growth of urban areas. The County must be specific and consistent about which lands will be maintained for the production of food and fiber and for support of the County’s economic base. The County’s strategy and overall framework for maintaining agriculture includes the following policy directed at the preservation of Important Farmland:



The overall economy of the County is expected to be dependent upon the agricultural industry for the foreseeable future. As such, all agricultural land in the County is considered as Important Farmland, as defined by federal and state agencies, and should be reserved for agricultural uses. Agricultural land may be converted to non-agricultural uses only where a clear and immediate need can be demonstrated, such as requirements for urban housing, commercial facilities, or employment opportunities. All existing agricultural land will be preserved for irrigation agriculture, livestock production, aquaculture, and other agriculture-related uses except for non-agricultural uses identified in this General Plan or in previously adopted City General Plans.

The following program is provided in the Agricultural Element:

No agricultural land designated except as provided in Exhibit C [of the Agricultural Element] shall be removed from the Agriculture category except where needed for use by a public agency, for geothermal purposes, where a mapping error may have occurred, or where a clear long-term economic benefit to the County can be demonstrated through the planning and environmental review process. The Board (or Planning Commission) shall be required to prepare and make specific findings and circulate same for 60 days (30 days for parcels considered under Exhibit C of this [Agricultural] element) before granting final approval of any proposal, which removes land from the Agriculture category.

Also, the following policy addresses Development Patterns and Locations on Agricultural Land:

“Leapfrogging” or “checkerboard” patterns of development have intensified recently and result in significant impacts on the efficient and economic production of adjacent agricultural land. It is a policy of the County that leapfrogging will not be allowed in the future. All new non-agricultural development will be confined to areas identified in this plan for such purposes or in Cities’ adopted Spheres of Influence, where new development must adjoin existing urban uses. Non-agricultural residential, commercial, or industrial uses will only be permitted if they adjoin at least one side of an existing urban use, and only if they do not significantly impact the ability to economically and conveniently farm adjacent agricultural land.

Agricultural Element Programs that address “leapfrogging” or “checkerboard” development include:

All non-agricultural uses in any land use category shall be analyzed during the subdivision, zoning, and environmental impact review process for their potential impact on the movement of agricultural equipment and products on roads located in the Agriculture category, and for other existing agricultural conditions which might impact the projects, such as noise, dust, or odors.

The Planning and Development Services Department shall review all proposed development projects to assure that any new residential or non-agricultural commercial uses located on agriculturally zoned land, except land designated as a Specific Plan Area, be adjoined on at least one entire property line to an area of existing urban uses. Developments that do not meet these criteria should not be approved.

Table 3.3-2 provides a General Plan goal and policy consistency evaluation for the project.

Table 3.3-2. Project Consistency with Applicable General Plan Agricultural Policies

General Plan Policies	Consistency with General Plan	Analysis
<p>Goal 1. All Important Farmland, including the categories of Prime Farmland, Farmland of Statewide Importance, Unique Farmland, and Farmland of Local Importance, as defined by federal and state agencies, should be reserved for agricultural uses.</p>	<p>Consistent</p>	<p>The project site does not contain Prime Farmland or Farmland of Statewide Importance. Therefore, the proposed project would not convert land designated as Prime Farmland or Farmland of Statewide Importance to non-agricultural uses. A portion of the project site is designated as Farmland of Local Importance. The project site is not currently utilized for agricultural production and has remained fallow for a period of time (exceeding five years). The proposed project would temporarily convert Farmland of Local Importance to non-agricultural uses. However, as part of the project, the project applicant or its successor in interest will be responsible for implementing a reclamation plan when the project is decommissioned at the end of its lifespan. The reclamation plan includes the removal, recycling, and/or disposal of all solar arrays, inverters, transformers, and other structures on the project site, as well as restoration of the site to its pre-project condition. Therefore, the proposed project would not permanently convert Farmland of Local Importance to non-agricultural uses.</p>
<p>Objective 1.5. Direct development to less valuable farmland (i.e., Unique Farmland and Farmland of Local Importance rather than Prime Farmland or Farmland of Statewide Importance) when conversion of agricultural land is justified.</p>	<p>Consistent</p>	<p>The project site is located within the County's designated Renewable Energy zone and is, therefore, considered to be located within an area that has been determined to be appropriate for the development of solar facilities. The majority of the project site is designated as Other Land. A portion of the project site is designated as Farmland of Local Importance. A reclamation plan would be prepared for the project site, which, when implemented, would return the site to existing conditions after the solar use is discontinued.</p>
<p>Objective 1.6. Recognize and preserve unincorporated areas of the County, outside of city sphere of influence areas, for irrigation agriculture, livestock production, aquaculture, and other special uses.</p>	<p>Consistent.</p>	<p>The project site is located within the County's designated Renewable Energy Zone and is, therefore, considered to be located within an area that has been determined to be appropriate for the development of solar facilities. The project would temporarily convert land located in an unincorporated area to non-agricultural uses; however, with the approval of a CUP, the project would be considered an allowable use in an agricultural zone as a conditionally-allowed use.</p>
<p>Objective 1.8. Allow conversion of agricultural land to non-agricultural uses including renewable energy only where a clear and immediate need can be demonstrated, based on economic benefits, population projections and lack of other available land (including land within</p>	<p>Consistent</p>	<p>The project site is located within the County's designated Renewable Energy Zone and is, therefore, consistent with the General Plan. Additionally, with the approval of a CUP, the project would be consistent with the County's Land Use Ordinance. Therefore, the project is consistent with the County's General Plan land</p>



Table 3.3-2. Project Consistency with Applicable General Plan Agricultural Policies

General Plan Policies	Consistency with General Plan	Analysis
<p>incorporated cities) for such non-agricultural uses. Such conversion shall also be allowed only where such uses have been identified for non-agricultural use in a city general plan or the County General Plan and are supported by a study to show a lack of alternative sites.</p>		<p>use designation.</p>
<p>Objective 1.11. Control and prevent soil erosion when possible.</p>	<p>Consistent</p>	<p>The project would implement BMPs within the site during construction and long-term operation of the project.</p>
<p>Goal 2. Adopt policies that prohibit “leapfrogging” or “checkerboard” patterns of nonagricultural development in agricultural areas and confine future urbanization to adopted Sphere of Influence area.</p>	<p>Consistent</p>	<p>The project is located within the County’s designated Renewable Energy Zone, which identifies areas that are considered appropriate for the development of renewable energy. The project does not include a residential component that would induce urbanization adjacent to the project. Furthermore, with the approval of a CUP, the project would be consistent with the County’s Land Use Ordinance. Consistency with the Land Use Ordinance implies consistency with the General Plan land use designation.</p>
<p>Objective 2.1. Do not allow the placement of new non-agricultural land uses such that agricultural fields or parcels become isolated or more difficult to economically and conveniently farm.</p>	<p>Consistent</p>	<p>The project is located within the County’s designated Renewable Energy Zone, which identifies areas that are considered appropriate for the development of renewable energy. Neither construction nor operation of the solar facility would not make it difficult to economically or conveniently farm.</p>
<p>Objective 2.2. Encourage the infilling of development in urban areas as an alternative to expanding urban boundaries.</p>	<p>Consistent</p>	<p>The project is located within the County’s designated Renewable Energy Zone, which identifies areas that are considered appropriate for the development of renewable energy. The project consists of the construction and operation of a solar facility. While the project would introduce development in the area, it would not include residential uses that would, in turn, create a demand for other uses, such as commercial, employments centers, and supporting services.</p>
<p>Objective 2.3. Maintain agricultural lands in parcel size configurations that help assure that viable farming units are retained.</p>	<p>Consistent</p>	<p>The project does not involve the subdivision of the property into smaller parcels. The project is considered a temporary industrial use but would not induce growth in the area nor result in the expansion of urban boundaries. While the project would temporarily convert agricultural land to non-agricultural uses; a reclamation plan would be prepared for the project site, which, when implemented, would return the site to its pre-project conditions after the solar uses are discontinued.</p>

Table 3.3-2. Project Consistency with Applicable General Plan Agricultural Policies

General Plan Policies	Consistency with General Plan	Analysis
Objective 2.4. Discourage the parcelization of large holdings.	Consistent	The project does not involve the subdivision of the property into smaller parcels. The size of the existing parcels would be retained for future agricultural use following site restoration.
Objective 2.6. Discourage the development of new residential or other non-agricultural areas outside of city “sphere of influence” unless designated for non-agricultural use in the County General Plan, or for necessary public facilities.	Consistent	The project is located within the County’s designated Renewable Energy Zone, which identifies areas that are considered appropriate for the development of renewable energy.
Goal 3. Limit the introduction of conflicting uses into farming areas, including residential development of existing parcels which may create the potential for conflict with continued agricultural use of adjacent property.	Consistent	Upon approval of a CUP, the proposed project would be an allowable use within the applicable agricultural zone. Additionally, the project does not include the development of housing. The solar development would be compatible with existing agricultural uses to the west.
Objective 3.2. Enforce the provisions of the Imperial County Right-to-Farm Ordinance (No. 1031).	Consistent	The Imperial County Right-to-Farm Ordinance would be enforced. Existing nuisance issues, such as noise, dust, and odors from existing agricultural use would not impact the project given the general lack of associated sensitive uses (e.g., residences). Likewise, with mitigation measures proposed in other resource sections (e.g., air quality, noise, etc.) project-related activities would not adversely affect adjacent agricultural operations.
Objective 3.3. Enforce the provisions of the State nuisance law (California Code Sub-Section 3482).	Consistent	The provisions of the state nuisance law would be incorporated into the project. As discussed below, there is the potential that weeds or other pests may occur within the solar field if these areas are not properly maintained and managed to control weeds and pests. Mitigation Measure AG-1 requires the project applicant to develop a Pest Management Plan prior to the issuance of a grading permit or building permit (whichever occurs first).

Source: County of Imperial 2015

BMP – best management practice; CUP – conditional use permit; IID – Imperial Irrigation District

3.3.3 Impacts and Mitigation Measures

This section presents the significance criteria used for considering project impacts related to agricultural resources, the methodology employed for the evaluation, an impact evaluation, and mitigation requirements, if necessary.

Thresholds of Significance

Based on CEQA Guidelines Appendix G, project impacts related to agricultural resources are considered significant if any of the following occur:

- Convert Prime Farmland, Unique Farmland, or Farmland of Statewide Importance (Farmland) as shown on the maps prepared pursuant to the FMMP of the California Resources Agency, to non-agricultural use
- Conflict with existing zoning for agricultural use, or a Williamson Act contract
- Involve other changes in the existing environment which, due to their location or nature, could result in conversion of Farmland, to non-agricultural use

Methodology

This analysis evaluates the potential for the project, as described in Chapter 2, Project Description, to adversely impact agricultural resources within the project site based on the applied significance criteria as identified above. The analysis prepared for this EIR relied on Important Farmland and Williamson Act maps for Imperial County produced by the California DOC's Division of Land Resource Protection. These sources were used to determine the agricultural significance of the land in the project site. Per the County of Imperial General Plan, Farmland of Local Importance is also considered an important farmland.

Additionally, potential conflicts with existing agricultural zoning or other changes resulting from the implementation of the project, which could indirectly remove Important Farmland from agricultural production or reduce agricultural productivity were considered. Sources used in this evaluation included, but were not limited to, the Imperial County General Plan and zoning ordinance. The conceptual site plan for the project (Chapter 2, Figure 2-3) was also used to evaluate potential impacts.

Impact Analysis

Impact 3.3-1 Would the project convert Prime Farmland, Unique Farmland, or Farmland of Statewide Importance (Farmland) as shown on the maps prepared pursuant to the FMMP of the California Resources Agency, to non-agricultural use?

The project site does not contain Prime Farmland, Farmland of Statewide Importance, or Unique Farmland. Therefore, the proposed project would not convert land designated as Prime Farmland, Farmland of Statewide Importance, or Unique Farmland to non-agricultural uses.

According to the California DOC's California Important Farmland Finder, the majority of the project site is designated as Other Land (DOC 2021). A portion of the project site is designated as Farmland of Local Importance. It should be noted that analysis of Other Land and Farmland of Local Importance is not required under CEQA significance criteria, as these designations are not considered an "agricultural land" per CEQA Statute Section 21060.1(a). The proposed project would temporarily convert Farmland of Local Importance to non-agricultural uses. However, as a condition of project approval (CUP condition), the project applicant or its successor in interest will be responsible for implementing a reclamation plan when the project is decommissioned at the end of its lifespan. The reclamation plan includes the removal, recycling, and/or disposal of all solar arrays, inverters, transformers, and other structures on the project site, as well as restoration of the site to its pre-project condition. The County is responsible for approving the reclamation plan for the project

and confirming that financial assurances for the project are in conformance with Imperial County ordinances prior to the issuance of any building permits. This shall be made a condition of approval and included in the CUP. Implementation of the reclamation plan would reduce the impact associated with the temporary conversion of Farmland of Local Importance to non-agricultural uses to a level less than significant.

Mitigation Measure(s)

No mitigation measures are required.

Impact 3.3-2 Would the project conflict with existing zoning for agricultural use, or a Williamson Act contract?

Williamson Act. The project site is not located on Williamson Act contracted land (DOC 2016). Therefore, the project would not conflict with a Williamson Act contract and no impact would occur.

Agricultural Zoning. Pursuant to the County General Plan, the project site is located on land designated for agricultural uses. The project would be constructed on land currently zoned A-3-RE (Heavy Agriculture with a Renewable Energy Zone Overlay). Pursuant to Title 9, Division 5, Chapter 9, the following uses are permitted in the A-3 zone subject to approval of a CUP from Imperial County:

i) Battery Storage Facility (must be connected to an existing electrical power generation plant such as solar, geothermal, wind, natural gas, or other renewable energy generator, as an accessory unit to said power plant).

oo) Major facilities relating to the generation and transmission of electrical energy, provided such facilities are not under State or Federal law, to [be] approved exclusively by an agency, or agencies of the State or Federal government, and provided such facilities shall be approved subsequent to coordination review of the Imperial Irrigation District for electrical matters, meeting the requirements in Division 17.

zz) Solar energy plants meeting the requirements in Division 17.

Upon approval of a CUP, the project's use would be consistent with the Imperial County Land Use Ordinance and thus is also consistent with the General Plan land use designation of the site. Additionally, the operation of the solar generating facility is not expected to inhibit or adversely affect adjacent agricultural operations through the placement of sensitive land uses, generation of excessive dust or shading, or place additional development pressures on adjacent areas. Based on these considerations, the impact is considered less than significant.

Mitigation Measure(s)

No mitigation measures are required.

Impact 3.3-3 Would the project involve other changes in the existing environment which, due to their location or nature, could result in conversion of Farmland, to non-agricultural use?

The Agricultural Element of the County's General Plan serves as the primary policy statement for implementing development policies for agricultural land use in Imperial County. The goals, objectives, implementation programs, and policies found in the Agricultural Element provide direction



for private development as well as government actions and programs. A summary of the relevant Agricultural goals and objectives and the project's consistency with applicable goals and objectives is summarized in Table 3.3-2. As provided, the project is generally consistent with certain Agricultural Element Goals and Objectives of the County General Plan.

Per County policy, agricultural land may be converted to non-agricultural uses only where a clear and immediate need can be demonstrated, such as requirements for urban housing, commercial facilities, or employment opportunities. Further, no agricultural land designated exempt shall be removed from the agriculture category except where needed for use by a public agency, for geothermal purposes, where a mapping error may have occurred, or where a clear long-term economic benefit to the County can be demonstrated through the planning and environmental review process.

As discussed under Impact 3.3-1, the project site does not contain Prime Farmland, Farmland of Statewide Importance, or Unique Farmland. Furthermore, the project site is located within the Renewable Energy Zone and is, therefore, considered an appropriate use in this area. Additionally, as a condition of project approval (CUP condition), the project applicant or its successor in interest will be responsible for implementing a reclamation plan when the project is decommissioned at the end of its lifespan. The reclamation plan includes the removal, recycling, and/or disposal of all solar arrays, inverters, transformers, and other structures on the project site, as well as restoration of the site to its pre-project condition. The County is responsible for approving the reclamation plan for the project and confirming that financial assurances for the project are in conformance with Imperial County ordinances prior to the issuance of any building permits. This shall be made a condition of approval and included in the CUP.

The nature of the project warrants that it be located adjacent to existing electrical transmission infrastructure. The electrical energy produced by the project would be conducted through the project's interconnection facilities to the proposed 92 kV gen-tie line and delivered to the existing IID approved POI on the 92 kV "P" Line. The All-American Main Canal provides a buffer between the proposed solar facility and the existing cultivated agricultural croplands located north of the canal. With the approval of a Conditional Use Permit, the project would be consistent with the County's Land Use Ordinance. Consistency with the Land Use Ordinance implies consistency with the General Plan land use designation.

The project would not directly impact the movement of agricultural equipment on roads located within the agriculture category and access to existing agriculture-serving roads would not be precluded or hindered by the project. No modifications to roadways are proposed in the project area that would otherwise affect other agricultural operations in the area. Furthermore, existing nuisance issues, such as noise, dust, and odors from existing agricultural use would not impact the project given the general lack of associated sensitive uses (e.g., residences). Likewise, with mitigation measures proposed in other resource sections (e.g., air quality, noise, etc.) project-related activities would not adversely affect adjacent agricultural operations. Further, the provisions of the Imperial County Right-to-Farm Ordinance (No. 1031) and the State nuisance law (California Code Sub-Section 3482) would continue to be enforced.

With the implementation of the project, it is possible that the physical and chemical makeup of the soil materials within the upper soil horizon may change. For example, improper soil stockpiling and management of the stockpiles could result in increased decomposition of soil organic materials, increased leaching of plant available nitrogen, and depletion of soil biota communities (e.g., Rhizobium or Frankia). Any reductions in agricultural productivity could significantly limit the types of

crops (e.g., deeper rooting crops, orchards, etc.) that may be grown within the project site in the future. However, as a condition of project approval (CUP condition), the project applicant or its successor in interest will be responsible for implementing a reclamation plan when the project is decommissioned at the end of its lifespan. The reclamation plan includes restoration of the site to its pre-project condition.

Additionally, there is the potential that weeds or other pests may occur within the solar field if the area is not properly maintained and managed to control weeds and pests. This is considered a significant impact. Implementation of Mitigation Measure AG-1 would reduce this impact to a level less than significant.

Mitigation Measure(s)

AG-1 Pest Management Plan. Prior to the issuance of a grading permit or building permit (whichever occurs first), a Pest Management Plan shall be developed by the project applicant and approved by the County of Imperial Agricultural Commissioner. The project applicant shall maintain a Pest Management Plan until reclamation is complete. The plan shall provide the following:

1. Monitoring, preventative, and management strategies for weed and pest control during construction activities at any portion of the project (e.g., transmission line);
2. Control and management of weeds and pests in areas temporarily disturbed during construction where native seed will aid in site revegetation as follows:
 - Monitor for all pests including insects, vertebrates, weeds, and pathogens. Promptly control or eradicate pests when found, or when notified by the Agricultural Commissioner's office that a pest problem is present on the project site. The assistance of a licensed pest control advisor is recommended. All treatments must be performed by a qualified applicator or a licensed pest control business;
 - All treatments must be performed by a qualified applicator or a licensed pest control operator;
 - "Control" means to reduce the population of common pests below economically damaging levels, and includes attempts to exclude pests before infestation, and effective control methods after infestation. Effective control methods may include physical/mechanical removal, bio control, cultural control, or chemical treatments;
 - Use of "permanent" soil sterilants to control weeds or other pests is prohibited because this would interfere with reclamation;
 - Notify the Agricultural Commissioner's office immediately regarding any suspected exotic/invasive pest species as defined by the California Department of Food Agriculture and the U.S. Department of Agriculture. Request a sample be taken by the Agricultural Commissioner's Office of a suspected invasive species. Eradication of exotic pests shall be done under the direction of the Agricultural Commissioner's Office and/or California Department of Food and Agriculture;
 - Obey all pesticide use laws, regulations, and permit conditions;

- Allow access by Agricultural Commissioner staff for routine visual and trap pest surveys, compliance inspections, eradication of exotic pests, and other official duties;
 - Ensure all project employees that handle pest control issues are appropriately trained and certified, all required records are maintained and made available for inspection, and all required permits and other required legal documents are current;
 - Maintain records of pests found and treatments or pest management methods used. Records should include the date, location/block, project name (current and previous if changed), and methods used. For pesticides include the chemical(s) used, EPA Registration numbers, application rates, etc. A pesticide use report may be used for this;
 - Submit a report of monitoring, pest finds, and treatments, or other pest management methods to the Agricultural Commissioner quarterly within 15 days after the end of the previous quarter, and upon request. The report is required even if no pests were found or treatment occurred. It may consist of a copy of all records for the previous quarter or may be a summary letter/report as long as the original detailed records are available upon request.
3. A long-term strategy for weed and pest control and management during the operation of the proposed project. Such strategies may include, but are not limited to:
- Use of specific types of herbicides and pesticides on a scheduled basis.
4. Maintenance and management of project site conditions to reduce the potential for a significant increase in pest-related nuisance conditions on surrounding agricultural lands.
5. The project shall reimburse the Agricultural Commissioner's office for the actual cost of investigations, inspections, or other required non-routine responses to the site that are not funded by other sources.

Significance after Mitigation

The project applicant would be required to adhere to the terms of the comprehensive reclamation plan that would restore the project site to preexisting (pre-project) conditions following decommissioning of the project (after their use for solar generation activities). In addition, the proposed project would be required to implement a weed and pest management control plan per Mitigation Measure AG-1. Compliance with these measures would reduce this impact to a level less than significant.

3.3.4 Decommissioning/Restoration and Residual Impacts

Decommissioning/Restoration

In any land restoration project, it is necessary to minimize disruption to topsoil or stockpiled topsoil for later use during restoration following project decommissioning. With the implementation of the project, it is possible that the physical and chemical makeup of the soil materials within the upper soil

horizon may change during construction and associated stockpiling operations. Improper soil stockpiling and management of the stockpiles could result in increased decomposition of soil organic materials, increased leaching of plant-available nitrogen, and depletion of soil biota communities (e.g., *Rhizobium* or *Frankia*). Each of these circumstances could have an adverse effect on the future productivity of the restored soils. Any reductions in agricultural productivity could significantly limit the types of crops (e.g., deeper rooting crops, orchards, etc.) that may be grown within the project site in the future. As a condition of project approval (CUP condition), the project applicant or its successor in interest will be responsible for implementing a reclamation plan when the project is decommissioned at the end of its lifespan. The reclamation plan includes restoration of the site to its pre-project condition. With implementation of the site reclamation plan, this impact is considered less than significant.

Residual

The project site does not contain Prime Farmland, Farmland of Statewide Importance, or Unique Farmland. Therefore, the proposed project would not convert land designated as Prime Farmland, Farmland of Statewide Importance, or Unique Farmland to non-agricultural uses. Operation of the project, subject to the approval of a CUP, would generally be consistent with applicable federal, state, regional, and local plans and policies. Following the proposed use (e.g., solar facility), the project would be decommissioned and the project site would be restored to pre-project conditions. Based on these circumstances, the project would not result in any residual significant and unmitigable impacts to agricultural resources.

3.4 Air Quality

This section includes an overview of the existing air quality within the project area and identifies applicable local, state, and federal policies related to air quality. The impact assessment provides an evaluation of potential adverse effects on air quality based on criteria derived from the CEQA Guidelines and Imperial County Air Pollution Control District's (ICAPCD) Air Quality Handbook in conjunction with actions proposed in Chapter 2, Project Description, of this EIR. ECORP Consulting, Inc. prepared an *Air Quality and Greenhouse Gas Assessment* that evaluates the potential air quality and climate change impacts of the VEGA SES 4 Solar Energy Project. This report is included in Appendix C of this EIR.

3.4.1 Existing Conditions

Regional Setting

The project is located in Imperial County within the Salton Sea Air Basin (SSAB). The SSAB consists of all of Imperial County and a portion of Riverside County. The ICAPCD has full jurisdiction within all Imperial County. As an arid desert region, the SSAB's climate is largely governed by the large-scale sinking and warming of air within the semi-permanent subtropical high-pressure center over the Pacific Ocean. When the fringes of mid-latitude storms pass through the Imperial Valley in winter, the coastal mountains create a strong "rain shadow" effect that makes Imperial Valley the second driest location in the U.S.

The lack of clouds and atmospheric moisture creates strong diurnal and seasonal temperature variations ranging from an average summer maximum of 108 degrees (°) Fahrenheit down to a winter morning minimum of 38° Fahrenheit. The most pleasant weather occurs from about mid-October to early May when daily highs are in the 70s and 80s with very infrequent cloudiness or rainfall. Imperial County experiences significant rainfall an average of only four times per year. The local area usually has three days of rain in winter and one thunderstorm day in August. The annual rainfall in this region is less than three inches per year (Appendix C of this EIR). Temperature inversions and light nighttime winds trap any local air pollution emissions near the ground. As a result, the area is subject to frequent hazy conditions at sunrise, followed by rapid daytime dissipation as winds pick up and the temperature warms. During periods of strong solar heating and intense convection, turbulent motion creates good mixing and low levels of air pollution. The SSAB experiences surface inversions almost every day of the year. These inversions often last for long periods of time, which allows for air stagnation and buildup of pollutants, including ozone (O₃).

Winds in the area are driven by a complex pattern of local, regional, and global forces, but primarily reflect the temperature difference between the cool ocean to the west and the heated interior of the entire desert southwest. For much of the year, winds flow predominantly from the west to the east. In summer, intense solar heating in the Imperial Valley creates a more localized wind pattern, as air comes up from the southeast via the Gulf of California.

Imperial County is predominately agricultural land, which is a factor in the cumulative air quality of the SSAB. Agricultural production generates dust and small particulate matter through the use of agricultural equipment on unpaved roads, land preparation, and harvest practices. Imperial County experiences unhealthy air quality from photochemical smog and from dust because of extensive surface disturbance and the very arid climate (Appendix C of this EIR).

Major Air Pollutants

Criteria Pollutants

Criteria air pollutants are defined as those pollutants for which the federal and state governments have established air quality standards for outdoor or ambient concentrations to protect public health with a determined margin of safety. Ozone, coarse particulate matter (PM₁₀), and fine particulate matter (PM_{2.5}) are generally considered to be regional pollutants because they or their precursors affect air quality on a regional scale. Pollutants such as carbon monoxide (CO), nitrogen dioxide (NO₂), and sulfur dioxide (SO₂) are considered to be local pollutants because they tend to accumulate in the air locally. PM is also considered a local pollutant. Health effects commonly associated with criteria pollutants are summarized in Table 3.4-1.

Table 3.4-1. Criteria Air Pollutants – Summary of Common Sources and Effects

Pollutant	Major Manmade Sources	Human Health and Welfare Effects
CO	An odorless, colorless gas formed when carbon in fuel is not burned completely; a component of motor vehicle exhaust.	Reduces the ability of blood to deliver oxygen to vital tissues, effecting the cardiovascular and nervous system. Impairs vision, causes dizziness, and can lead to unconsciousness or death.
NO ₂	A reddish-brown gas formed during fuel combustion for motor vehicles, energy utilities and industrial sources.	Respiratory irritant; aggravates lung and heart problems. Precursor to ozone and acid rain. Causes brown discoloration of the atmosphere.
O ₃	Formed by a chemical reaction between reactive organic gases (ROGs) and nitrous oxides (N ₂ O) in the presence of sunlight. Common sources of these precursor pollutants include motor vehicle exhaust, industrial emissions, solvents, paints and landfills.	Irritates and causes inflammation of the mucous membranes and lung airways; causes wheezing, coughing and pain when inhaling deeply; decreases lung capacity; aggravates lung and heart problems. Damages plants; reduces crop yield.
PM ₁₀ and PM _{2.5}	Power plants, steel mills, chemical plants, unpaved roads and parking lots, wood-burning stoves and fireplaces, automobiles and others.	Increased respiratory symptoms, such as irritation of the airways, coughing, or difficulty breathing; aggravated asthma; development of chronic bronchitis; irregular heartbeat; nonfatal heart attacks; and premature death in people with heart or lung disease. Impairs visibility (haze)
SO ₂	A colorless, nonflammable gas formed when fuel containing sulfur is burned. Examples are refineries, cement manufacturing, and locomotives.	Respiratory irritant. Aggravates lung and heart problems. Can damage crops and natural vegetation. Impairs visibility.

Source: Appendix C of this EIR

Toxic Air Contaminants

Toxic air contaminants (TAC) are substances that have the potential to be emitted into the ambient air and that have been determined to present some level of acute or chronic health risk (cancer or non-cancer) to the general public. These pollutants may be emitted in trace amounts from various types of sources, including combustion sources. There are almost 200 compounds that have been designated as TACs in California. The 10 TACs posing the greatest known health risk in California, based primarily

on ambient air quality data, are acetaldehyde, benzene, 1,3-butadiene, carbon tetrachloride, hexavalent chromium, formaldehyde, methylene chloride, para-dichlorobenzene, perchloroethylene, and diesel particulate matter (DPM).

Most recently, CARB identified DPM as a TAC. DPM differs from other TACs in that it is not a single substance but rather a complex mixture of hundreds of substances. Diesel exhaust is a complex mixture of particles and gases produced when an engine burns diesel fuel. DPM is a concern because it causes lung cancer; many compounds found in diesel exhaust are carcinogenic. DPM includes the particle-phase constituents in diesel exhaust. The chemical composition and particle sizes of DPM vary between different engine types (heavy-duty, light-duty), engine operating conditions (idle, accelerate, decelerate), fuel formulations (high/low sulfur fuel), and the year of the engine. Some short-term (acute) effects of diesel exhaust include eye, nose, throat, and lung irritation, and diesel exhaust can cause coughs, headaches, light-headedness, and nausea. DPM poses the greatest health risk among the TACs; due to their extremely small size, these particles can be inhaled and eventually trapped in the bronchial and alveolar regions of the lung (Appendix C of this EIR).

Attainment Status

The U.S. Environmental Protection Agency (EPA) and California Air Resources Board (CARB) designate air basins or portions of air basins and counties as being in “attainment” or “nonattainment” for each of the criteria pollutants. Areas that do not meet the standards are classified as nonattainment areas. The National Ambient Air Quality Standards (NAAQS) (other than O₃, PM₁₀ and PM_{2.5} and those based on annual averages or arithmetic mean) are not to be exceeded more than once per year. The NAAQS for O₃, PM₁₀, and PM_{2.5} are based on statistical calculations over one- to three-year periods, depending on the pollutant. The California Ambient Air Quality Standards (CAAQS) are not to be exceeded during a three-year period.

The attainment status for the portion of the SSAB encompassing the project site is shown in Table 3.4-2. As shown, the Imperial County portion of the SSAB is currently designated as nonattainment for O₃ and PM₁₀ under State standards. Under federal standards, the Imperial County portion of the SSAB is in nonattainment for O₃ and PM_{2.5} and is in attainment for PM₁₀. The area is currently in attainment or unclassified status for CO, NO₂, and SO₂.

Table 3.4-2. Attainment Status of Criteria Pollutants in the Imperial County Portion of the Salton Sea Air Basin

Pollutant	State Designation	Federal Designation
O ₃	Nonattainment	Nonattainment
PM ₁₀	Nonattainment	Attainment
PM _{2.5}	Attainment	Nonattainment
CO	Attainment	Unclassified/attainment
NO ₂	Attainment	Unclassified/attainment
SO ₂	Attainment	Unclassified/attainment

Source: Appendix C of this EIR

Local Ambient Air Quality

Ambient air quality at the project site can be inferred from ambient air quality measurements conducted at nearby air quality monitoring stations. CARB maintains more than 60 monitoring stations throughout California. Ozone, PM₁₀ and PM_{2.5} are the pollutants most potently affecting the project region. As described above, the project region is designated as a nonattainment area for the federal O₃ and PM_{2.5} standards and is also a nonattainment area for the State standards for O₃ and PM₁₀. The Niland-English Road air quality monitoring station (7711 English Road, Niland), located approximately 23.0 miles northwest of the project site, monitors ambient concentrations of O₃ and PM₁₀. The Brawley-Main Street #2 air quality monitoring station (220 Main Street, Brawley), located 15.0 miles west of the project site, monitors ambient concentrations of PM_{2.5}. Ambient emission concentrations will vary due to localized variations in emission sources and climate and should be considered “generally” representative of ambient concentrations in the project area. Table 3.4-3 summarizes the published data concerning O₃, PM_{2.5} and PM₁₀ from the Niland-English Road and Brawley-Main Street #2 monitoring stations for monitoring years 2018-2020. As shown in Table 3.4-3, O₃, PM₁₀ and PM_{2.5} are the pollutants most potently affecting the project region.

Table 3.4-3. Summary of Local Ambient Air Quality Data

Pollutant Standards	2018	2019	2020
O₃ – Niland-English Road			
Max 1-hour concentration (ppm)	0.060	0,060	0.054
Max 8-hour concentration (ppm) (state/federal)	0.055 / 0.055	0.055 / 0.054	0.046 / 0.045
Number of days above 1-hour standard (state/federal)	0 / 0	0 / 0	0 / 0
Number of days above 8-hour standard (state/federal)	0 / 0	0 / 0	0 / 0
PM₁₀ – Niland-English Road			
Max 24-hour concentration (µg/m3) (state/federal)	333.8 / 331.5	156.3 / 155.7	241.3 / 239.8
Number of days above 24-hour standard (state/federal)	* / 10.1	49.3 / 1.0	68.9 / 1.0
PM_{2.5} – Brawley-Main Street			
Max 24-hour concentration (µg/m3) (state/federal)	55.1 / 55.1	28.9 / 28.9	23.7 / 23.7
Number of days above federal 24-hour standard	6.1	0	0

Source: Appendix C of this EIR

µg/m3 = micrograms per cubic meter; ppm = parts per million

* = Insufficient data available

Sensitive Receptors

High concentrations of air pollutants pose health hazards for the general population, but particularly for the young, the elderly, and the sick. Typical health problems attributed to smog include respiratory ailments, eye and throat irritations, headaches, coughing, and chest discomfort. Certain land uses are considered to be more sensitive to the effects of air pollution. Schools, hospitals, residences, and other

facilities where people congregate, especially children, the elderly and infirm, are considered particularly sensitive to air pollutants.

The project site is in a generally rural area and surrounded by relatively undisturbed desert lands. The nearest sensitive receptor to the project site is a single-family residence located approximately 0.5 miles from the northeastern corner of the project site.

3.4.2 Regulatory Setting

This section identifies and summarizes federal, state, and local laws, policies, and regulations that are applicable to the project.

Federal

Clean Air Act

The Federal Clean Air Act (CAA), passed in 1970 and last amended in 1990, is the primary federal law that governs air quality. The Federal CAA delegates primary responsibility for clean air to the U.S. EPA. The U.S. EPA develops rules and regulations to preserve and improve air quality and delegates specific responsibilities to state and local agencies. Under the act, the U.S. EPA has established the NAAQS for six criteria air pollutants that are pervasive in urban environments and for which state and national health-based ambient air quality standards have been established. Ozone, CO, NO₂, SO₂, Pb, and PM (including both PM₁₀, and PM_{2.5}) are the six criteria air pollutants. Ozone is a secondary pollutant, nitrogen oxides (NO_x) and volatile organic compounds (VOCs) are of particular interest as they are precursors to ozone formation. In addition, national standards exist for Pb. The NAAQS standards are set at levels that protect public health with a margin of safety and are subject to periodic review and revision.

The Federal CAA requires U.S EPA to designate areas as attainment, nonattainment, or maintenance (previously nonattainment and currently attainment) for each criteria pollutant based on whether the NAAQS have been achieved. The federal standards are summarized in Table 3.4-4.

State

California Clean Air Act

The California Clean Air Act (CCAA) was adopted by CARB in 1988. The CCAA is responsible for meeting the state requirements of the Federal CAA and for establishing the CAAQS. CARB oversees the functions of local air pollution control districts and air quality management districts, which, in turn, administer air quality activities at the regional and county levels. The CCAA, as amended in 1992, requires all air districts of the state to achieve and maintain the CAAQS by the earliest practical date.

The CCAA requires CARB to designate areas within California as either attainment or nonattainment for each criteria pollutant based on whether the CAAQS have been achieved. Under the CCAA, areas are designated as nonattainment for a pollutant if air quality data shows that a state standard for the pollutant was violated at least once during the previous 3 calendar years. As shown in Table 3.4-4, the CAAQS are generally more stringent than the corresponding federal standards and incorporate additional standards for sulfates, hydrogen sulfide, vinyl chloride, and visibility-reducing particles. Exceedances that are affected by highly irregular or infrequent events are not considered violations of a state standard and are not used as a basis for designating areas as nonattainment.

California State Implementation Plan

The CAA mandates that the state submit and implement a State Implementation Plan (SIP) for areas not meeting the NAAQS. These plans must include pollution control measures that demonstrate how the standards will be met. State law makes CARB the lead agency for all purposes related to the SIP. Local air districts and other agencies prepare SIP elements and submit them to CARB for review and approval. CARB then forwards SIP revisions to the U.S. EPA for approval and publication in the Federal Register. The Code of Federal Regulations Title 40, Chapter I, Part 52, Subpart F, Section 52.220 lists all of the items which are included in the California SIP.

Table 3.4-4. Ambient Air Quality Standards

Air Pollutant	Averaging Time	California Standard	National Standard
O ₃	1-hour	0.09 ppm	--
	8-hour	0.070 ppm	0.070 ppm
PM ₁₀	24-hour Mean	50 µg/m ³	150 µg/m ³
		20 µg/m ³	--
PM _{2.5}	24-hour Mean	--	35 µg/m ³
		12 µg/m ³	12.0 µg/m ³
CO	1-hour 8-hour	20 ppm	35 ppm
		9.0 ppm	9 ppm
NO ₂	1-hour Mean	0.18 ppm	100 ppb
		0.030 ppm	0.053 ppm
SO ₂	1-hour 24-hour	0.25 ppm	75 ppb
		0.04 ppm	--
Pb	30-day Rolling 3-month	1.5 µg/m ³	-- 0.15 µg/m ³
Sulfates	24-hour	25 µg/m ³	No federal standard
Hydrogen sulfide	1-hour	0.03 ppm	
Vinyl chloride	24-hour	0.01 ppm	
Visibility-reducing particles	8-hour	Extinction coefficient of	
		0.23 per kilometer, visibility of 10 miles or more because of particles when relative humidity is less than 70 percent	

Source: CARB 2016

CO – carbon monoxide; mean – annual arithmetic mean; NO₂ – nitrogen dioxide; O₃ – ozone; Pb – lead; PM_{2.5} – particulate matter less than 2.5 microns in diameter; PM₁₀ – particulate matter less than 10 microns in diameter; ppb – parts per billion; ppm – parts per million; SO₂ – sulfur dioxide; µg/m³ – micrograms per cubic meter

Toxic Air Contaminants Regulation

TAC sources include industrial processes, dry cleaners, gasoline stations, paint and solvent operations, and fossil fuel combustion sources. The TACs that are relevant to the implementation of the project include DPM and airborne asbestos.

In August 1998, ARB identified DPM emissions from diesel-fueled engines as a TAC. In September 2000, ARB approved a comprehensive diesel risk reduction plan to reduce emissions from both new and existing diesel fueled engines and vehicles. The goal of the plan is to reduce diesel PM₁₀ (inhalable particulate matter) emissions and the associated health risk by 75 percent in 2010 and by 85 percent by 2020. The plan identified 14 measures that target new and existing on-road vehicles (e.g., heavy duty trucks and buses, etc.), off-road equipment (e.g., graders, tractors, forklifts, sweepers, and boats), portable equipment (e.g., pumps, etc.), and stationary engines (e.g., stand-by power generators, etc.).

Tanner Air Toxics Act & Air Toxics "Hot Spots" Information and Assessment Act

CARB's Statewide comprehensive air toxics program was established in 1983 with Assembly Bill (AB) 1807, the Toxic Air Contaminant Identification and Control Act (Tanner Air Toxics Act of 1983). AB 1807 created California's program to reduce exposure to air toxics and sets forth a formal procedure for CARB to designate substances as TACs. Once a TAC is identified, CARB adopts an airborne toxics control measure (ATCM) for sources that emit designated TACs. If there is a safe threshold for a substance at which there is no toxic effect, the control measure must reduce exposure to below that threshold. If there is no safe threshold, the measure must incorporate toxics best available control technology to minimize emissions.

CARB also administers the state's mobile source emissions control program and oversees air quality programs established by state statute, such as AB 2588, the Air Toxics "Hot Spots" Information and Assessment Act of 1987. Under AB 2588, TAC emissions from individual facilities are quantified and prioritized by the air quality management district or air pollution control district. High priority facilities are required to perform a health risk assessment (HRA) and, if specific thresholds are exceeded, required to communicate the results to the public in the form of notices and public meetings. In September 1992, the "Hot Spots" Act was amended by Senate Bill (SB) 1731, which required facilities that pose a significant health risk to the community to reduce their risk through a risk management plan.

Regional

Imperial County Air Pollution Control District

The ICAPCD is the agency responsible for monitoring air quality, as well as planning, implementing, and enforcing programs designed to attain and maintain state and federal ambient air quality standards in the district. ICAPCD is responsible for regulating stationary sources of air emissions in Imperial County. Stationary sources that have the potential to emit air pollutants into the ambient air are subject to the Rules and Regulations adopted by ICAPCD. ICAPCD is responsible for establishing stationary source permitting requirements and for ensuring that new, modified, or relocated stationary sources do not create net emission increases. Monitoring of ambient air quality in Imperial County began in 1976. Since that time, monitoring has been performed by ICAPCD, CARB, and by private industry. There are six monitoring sites in Imperial County from Niland to Calexico. The ICAPCD has developed the following plans to achieve attainment for air quality ambient standards.

- 2009 Imperial County Plan for PM₁₀

- 2013 Imperial County Plan for 2006 24-hour PM_{2.5} for Moderate Nonattainment Area
- 2017 Imperial County Plan for 2008 8-hour Ozone Standard
- 2018 Imperial County Plan for PM₁₀
- 2018 Redesignation Request and Maintenance Plan for PM₁₀
- 2018 Imperial County Plan for PM_{2.5}

In addition to the above plans, the ICAPCD is working cooperatively with counterparts from Mexico to implement emissions reductions strategies and projects for air quality improvements at the border. The two countries strive to achieve these goals through local input from states, county governments, and citizens. Within the Mexicali and Imperial Valley area, the Air Quality Task Force has been organized to address those issues unique to the border region known as the Mexicali/Imperial air shed. The Air Quality Task Force membership includes representatives from federal, State, and local governments from both sides of the border, as well as representatives from academia, environmental organizations, and the general public. This group was created to promote regional efforts to improve the air quality monitoring network, emissions inventories, and air pollution transport modeling development, as well as the creation of programs and strategies to improve air quality.

Imperial County Air Pollution Control District Rules and Regulations

ICAPCD has the authority to adopt and enforce regulations dealing with controls for specific types of sources, emissions or hazardous air pollutants, and New Source Review. The ICAPCD Rules and Regulations are part of the SIP and are separately enforceable by the EPA.

Rule 106 – Abatement. The Board may, after notice and a hearing, issue, or provide for the issuance by the Hearing Board, of an order for abatement whenever the District finds that any person is in violation of the rules and regulations limiting the discharge of air contaminants into the atmosphere.

Rule 107 – Land Use. The purpose of this rule is to provide ICAPCD the duty to review and advise the appropriate planning authorities within the District on all new construction or changes in land use which the Air Pollution Control Officer believes could become a source of air pollution problems.

Rule 201 – Permits Required. The construction, installation, modification, replacement, and operation of any equipment which may emit or control Air Contaminants require ICAPCD permits.

Rule 207 – New and Modified Stationary Source Review. Establishes preconstruction review requirements for new and modified stationary sources to ensure the operations of equipment does not interfere with attainment or maintenance of ambient air quality standards.

Rule 208 – Permit to Operate. The ICAPCD would inspect and evaluate the facility to ensure the facility has been constructed or installed and will operate to comply with the provisions of the Authority to Construct permit and comply with all applicable laws, rules, standards, and guidelines.

Rule 310 – Operational Development Fee. The purpose of this rule is to provide ICAPCD with a sound method for mitigating the emissions produced from the operation of new commercial and residential development projects throughout the County of Imperial and incorporated cities. All project proponents have the option to either provide off-site mitigation, pay the operational development fee, or do a combination of both. This rule will assist ICAPCD in attaining the state and federal ambient air quality standards for PM₁₀ and O₃.

Rule 401 – Opacity of Emissions. Sets limits for release or discharge of emissions into the atmosphere, other than uncombined water vapor, that are dark or darker in shade as designated as



No.1 on the Ringelmann Chart¹ or obscure an observer’s view to a degree equal to or greater than smoke does as compared to No.1 on the Ringelmann Chart, for a period or aggregated period of more than three minutes in any hour.

Rule 403 – General Limitations on the Discharge of Air Contaminants. Rule 403 sets forth limitations on emissions of pollutants, including particulate matter, from individual sources.

Rule 407 – Nuisance. Rule 407 prohibits a person from discharging from any source whatsoever such quantities of air contaminants or other material which cause injury, detriment, nuisance or annoyance to any considerable number of persons or to the public, or which endanger the comfort, repose, health or safety of any such persons or the public, or which cause, or have a natural tendency to cause, injury or damage to business or property.

Rule 801 – Construction and Earthmoving Activities. Rule 801 aims to reduce the amount of PM₁₀ entrained in the ambient air as a result of emissions generated from construction and other earthmoving activities by requiring actions to prevent, reduce, or mitigate PM₁₀ emissions. This rule applies to any construction and other earthmoving activities, including, but not limited to, land clearing, excavation related to construction, land leveling, grading, cut and fill grading, erection or demolition of any structure, cutting and filling, trenching, loading or unloading of bulk materials, demolishing, drilling, adding to or removing bulk of materials from open storage piles, weed abatement through disking, back filling, travel on-site and travel on access roads to and from the site.

Regulation VIII – Fugitive Dust Rules. Regulation VIII sets forth rules regarding the control of fugitive dust, including fugitive dust from construction activities. The regulation requires implementation of fugitive dust control measures to reduce emissions from earthmoving, unpaved roads, handling of bulk materials, and control of track-out/carry-out dust from active construction sites. Best Available Control Measures to reduce fugitive dust during construction and earthmoving activities include but are not limited to:

- Phasing of work in order to minimize disturbed surface area
- Application of water or chemical stabilizers to disturbed soils
- Construction and maintenance of wind barriers
- Use of a track-out control device or wash down system at access points to paved roads.

Compliance with Regulation VIII is mandatory for all construction sites, regardless of size; however, compliance with Regulation VIII does not constitute mitigation under the reductions attributed to environmental impacts. In addition, compliance for a project includes: (1) the development of a dust control plan for the construction and operational phase; and (2) notification to the Air District is required 10 days prior to the commencement of any construction activity. Furthermore, any use of engine(s) and/or generator(s) of 50 horsepower or greater may require a permit through ICAPCD.

Southern California Association of Governments – 2020-2045 Regional Transportation Plan/Sustainable Communities Strategy

The Southern California Association of Governments (SCAG) is the designated metropolitan planning organization for Los Angeles, Ventura, Orange, San Bernardino, Riverside, and Imperial Counties. CEQA requires that regional agencies like SCAG review projects and plans throughout its jurisdiction. SCAG, as the region’s “Clearinghouse,” collects information on projects of varying size and scope to

¹ The Ringelmann scale is a scale for measuring the apparent density or opacity of smoke.

provide a central point to monitor regional activity. SCAG has the responsibility of reviewing dozens of projects, plans, and programs every month. Projects and plans that are regionally significant must demonstrate to SCAG their consistency with a range of adopted regional plans and policies.

On September 3, 2020, SCAG adopted the 2020-2045 Regional Transportation Plan/Sustainable Communities Strategy (RTP/SCS) (SCAG 2020). The RTP/SCS or “Connect SoCal” includes a strong commitment to reduce emissions from transportation sources to comply with Senate Bill 375, improve public health, and meet the NAAQS as set forth by the federal CAA. The following SCAG goal is applicable to the project:

- Reduce greenhouse gas emissions and improve air quality

As a solar generation facility, the proposed project would improve air quality by reducing the use of fossil fuels in energy production. Construction of the proposed project would not exceed any ICAPCD thresholds or result in significant impacts to air quality. Although no significant air quality impact would occur during construction, all construction projects within Imperial County must comply with the requirements of ICAPCD Regulation VIII for the control of fugitive dust. PM₁₀ emissions associated with construction of the project would be reduced through compliance with ICAPCD Regulation VIII. Operation of the proposed project would not exceed any ICAPCD thresholds or result in significant impacts to air quality. Therefore, the proposed project would be consistent with this SCAG goal.

Imperial County General Plan

The Imperial County General Plan serves as the overall guiding policy for the County. The Conservation and Open Space Element includes objectives for helping the County achieve the goal of improving and maintaining the quality of air in the region. Table 3.4-5 summarizes the project’s consistency with the applicable air quality goal and objectives from the Conservation and Open Space Element. While this EIR analyzes the project’s consistency with the General Plan pursuant to State CEQA Guidelines Section 15125(d), the Imperial County Board of Supervisors ultimately determines consistency with the General Plan.

Table 3.4-5. Project Consistency with Applicable Plan Policies

Applicable Policies	Consistency Determination	Analysis
<i>Conservation and Open Space Element</i>		
Protection of Air Quality and Addressing Climate Change Goal 7: The County shall actively seek to improve the quality of air in the region.	Consistent	The proposed project would be required to comply with all applicable ICAPCD rules and requirements during construction and operation to reduce air emissions. Overall, the proposed project would improve air quality and reduce GHG emissions by reducing the amount of emissions that would be generated in association with electricity production from fossil fuel burning facilities. Therefore, the proposed project is consistent with this goal.

Table 3.4-5. Project Consistency with Applicable Plan Policies

Applicable Policies	Consistency Determination	Analysis
Objective 7.1: Ensure that all project and facilities comply with current Federal, State and local requirements for attainment of air quality objectives.	Consistent	The proposed project would comply with current federal and State requirements for attainment for air quality objectives through conformance with all applicable ICAPCD rules and requirements to reduce fugitive dust and emissions. Further, the project would comply with the ICAPCD Air Quality CEQA Handbook’s Mandatory Standard, Discretionary and Enhanced Air Quality Measures (Mitigation Measure AQ-1). Therefore, the proposed project is consistent with this objective.
Objective 7.2: Develop management strategies to mitigate fugitive dust. Cooperate with all federal and state agencies in the effort to attain air quality objectives.	Consistent	The Applicant would cooperate with all federal and State agencies in the effort to attain air quality objectives through compliance with the ICAPCD Air Quality CEQA Handbook’s Mandatory Standard, Discretionary and Enhanced Air Quality Measures (Mitigation Measure AQ-1). Therefore, the proposed project is consistent with this objective.

Source: County of Imperial 2016

3.4.3 Impacts and Mitigation Measures

This section presents the significance criteria used for considering project impacts related to air quality, the methodology employed for the evaluation, an impact evaluation, and mitigation requirements, if necessary.

Thresholds of Significance

Based on CEQA Guidelines Appendix G, project impacts related to air quality are considered significant if any of the following occur:

- Conflict with or obstruct implementation of the applicable air quality plan
- Result in a cumulatively considerable net increase of any criteria pollutant for which the project region is non-attainment under an applicable federal or state ambient air quality standard (including releasing emissions which exceed quantitative thresholds for O₃ precursors)
- Expose sensitive receptors to substantial pollutant concentrations
- Result in other emissions (such as those leading to odors) adversely affecting a substantial number of people

Imperial County Air Pollution Control District

ICAPCD amended the Air Quality Handbook: Guidelines for the Implementation of CEQA on December 12, 2017 (ICAPCD 2017b). ICAPCD established significance thresholds based on the state CEQA thresholds. The handbook was used to determine the proper level of analysis for the project.

Significance thresholds for evaluation construction and operational air quality impacts are listed in Table 3.4-6.

Projects that are predicted to exceed Tier I thresholds require implementation of applicable ICAPCD standard mitigation measures to be considered less than significant. Projects exceeding Tier II

thresholds are required to implement applicable ICAPCD standard mitigation measures, as well as applicable discretionary mitigation measures. Projects that exceed the Tier II thresholds after implementation of standard and discretionary mitigation measures would be considered to have a potentially significant impact to human health and welfare.

By its very nature, air pollution is largely a cumulative impact. No single project is sufficient in size, by itself, to result in nonattainment of ambient air quality standards. Instead, a project’s individual emissions contribute to existing cumulatively significant adverse air quality impacts. If a project’s individual emissions exceed its identified significance thresholds, the project would be cumulatively considerable. Projects that do not exceed significance thresholds would not be considered cumulative considerable.

Table 3.4-6. Imperial County Air Pollution Control District Significance Thresholds – Pounds per Day

Criteria Pollutant and Precursors	Construction Activities	Tier 2 Thresholds	
	Average Daily Emissions (lbs/day)	Average Daily Emissions (lbs/day)	
		Tier I Threshold	Tier II Threshold
ROG	75	<137	>137
NO _x	100	<137	>137
PM ₁₀	150	<150	>150
PM _{2.5}	N/A	<550	>550
CO	550	<550	>550
SO ₂	N/A	<150	>150

Source: ICAPCD 2017b

CO – carbon monoxide; NO_x – nitrogen oxide; O₃ – ozone; Pb – lead; PM_{2.5} – particulate matter less than 2.5 microns in diameter; PM₁₀ – particulate matter less than 10 microns in diameter; ROG – reactive organic gas; SO_x – sulfur oxide

Methodology

Air quality impacts were assessed in accordance with methodologies recommended by the ICAPCD. Where criteria air pollutant quantification was required, emissions were modeled using the California Emissions Estimator Model (CalEEMod), version 2020.4.0. CalEEMod is a statewide land use emissions computer model designed to quantify potential criteria pollutant emissions associated with both construction and operations from a variety of land use projects. Project construction-generated air pollutant emissions were calculated using CalEEMod model defaults for Imperial County coupled with information provided by the project applicant. For instance, construction activities would primarily involve demolition and grubbing, grading of the project site to establish access roads and pads for electrical equipment, trenching for underground electrical collection lines, and the installation of solar equipment and security fencing. Construction is estimated to take 12-18 months and would begin in late 2022 or 2023. The number of on-site construction workers for the solar facility is not expected to exceed 150 workers at any time. The number of on-site construction workers for the BESS and substation is not expected to exceed 100 workers at any one time. According to the Traffic Study prepared for the project, project construction would generate a maximum of 500 construction worker-commute trips in a single day.

Construction workers would utilize an existing driveway off State Route 98 and then park their vehicles in a designated staging/parking area, approximately 3.5 acres in size, north of the All-American Canal. The staging/parking area is proposed to be improved to facilitate access and minimize parking conflicts. Construction workers would then walk across the All-American Canal at an existing crossing east of the project site. No vehicles or construction vehicles are allowed to travel across this existing crossing. Designated shuttles would pick up the construction workers at the south end of the crossing, and then travel west for approximately one mile along an existing dirt road to the project site. The Traffic Impact Study prepared for the project identifies the site trip distribution of construction worker commute traffic. It is noted that all of the roadways identified as construction worker commute routes are paved. Thus, the PM emissions associated with construction workers traversing 1.15 miles of unpaved roads are accounted (0.15 mile of roadway at staging/parking area and 1.0 mile of dirt road south of the All-American Canal).

All heavy-duty construction vehicles would cross the All-American Canal at Gordon Wells Road located approximately 20 miles east of the project site. An estimated two trucks hauling construction equipment and project materials would arrive at the project site each day during the first few weeks of construction via Gordon Wells Road and the 20 miles of existing dirt road paralleling the U.S./Mexico Border. The PM emissions associated with two haul trucks traversing this existing dirt road to and from the site daily are accounted for.

Operational air pollutant emissions account for the maximum three workers visiting the site in a single day. Such visits include inspections, equipment servicing, site and landscape clearing, and periodic washing of the PV modules if needed (up to two times per year) to maintain power generation efficiency. Therefore, operational onsite equipment use is accounted in addition to the consumption of 10 acre-feet (3,259,000 gallons) of water annually.

Impact Analysis

Impact 3.4-1 Would the project conflict with or obstruct implementation of the applicable air quality plan?

The air quality attainment plan (AQAP) for the SSAB, through the implementation of the AQMP (previously AQAP) and SIP for PM₁₀, sets forth a comprehensive program that will lead the SSAB into compliance with all federal and state air quality standards. The AQMP control measures and related emission reduction estimates are based upon emissions projections for a future development scenario derived from land use, population, and employment characteristics defined in consultation with local governments. Conformance with the AQMP for development projects is determined by demonstrating compliance with local land use plans and/or population projections, meeting the land use designation set forth in the local General Plan, and comparing assumed emissions in the AQMP to proposed emissions.

The project must demonstrate compliance with all ICAPCD applicable rules and regulations, as well as local land use plans and population projections. As the project does not contain a residential component, the project would not result in an increase in the regional population. While the project would contribute to energy supply, which is one factor of population growth, the proposed project is a solar energy project and would not significantly increase employment or growth within the region. Moreover, development of the proposed project would increase the amount of renewable energy and help California meet its Renewable Portfolio Standard (RPS).

As shown in Table 3.4-5, the project is consistent with the applicable air quality goal and objectives from the Conservation and Open Space Element of the General Plan. The proposed project would be required to comply with all applicable ICAPCD rules and requirements during construction and operation to reduce air emissions. Overall, the proposed project would improve air quality by reducing the amount of emissions that would be generated in association with electricity production from fossil fuel burning facilities.

Furthermore, the thresholds of significance adopted by the air district (ICAPCD), determine compliance with the goals of the attainment plans in the region. As such, emissions below the ICAPCD thresholds presented in Table 3.4-6 would not conflict with or obstruct implementation of the applicable air quality plans. The following analysis is broken out by a discussion of potential impacts during construction of the project followed by a discussion of potential impacts during operation of the project.

Construction Emissions. Air emissions are generated during construction through activities. Two basic sources of short-term emissions will be generated through project construction: operation of heavy-duty equipment (i.e., excavators, loaders, haul trucks) and the creation of fugitive dust during clearing, grading, and commuting on any exposed surfaces. The project site would be accessed via the following:

- **Worker Access:** Workers would utilize an existing driveway off State Route 98. Workers would cross the All-American Canal at an existing crossing east of the project site and then travel west for approximately one mile along an existing dirt road.
- **Heavy Construction Equipment Access:** Vendors and heavy construction equipment would exit south from Interstate 8 onto Gordon Wells Road approximately 20 miles east of the project site, then travel west along an existing dirt road paralleling the U.S./Mexico Border.

Construction activities such as excavation and grading operations, construction vehicle traffic, and wind blowing over exposed soils would generate exhaust emissions and fugitive PM emissions that affect local air quality at various times during construction. Construction emissions vary from day-to-day depending on the number of workers, number, and types of active heavy-duty vehicles and equipment, level of activity, the prevailing meteorological conditions, and the length over which these activities occur.

The proposed project is anticipated to take approximately 12-18 months from the commencement of the construction process to complete. Construction is anticipated to begin in late 2022 and/or 2023. Construction activities would primarily involve demolition and grubbing, grading of the project site to establish access roads and pads for electrical equipment, trenching for underground electrical collection lines, and the installation of solar equipment and security fencing. The construction emissions were calculated using the CARB-approved CalEEMod computer program, which is designed to model emissions for land use development projects, based on typical construction requirements.

The total emissions generated within each year of project construction are shown in Table 3.4-7.



Table 3.4-7. Project Construction-Generated Emissions – Unmitigated

Construction Year	Pollutant (pounds per day)					
	ROG	NO _x	CO	SO ₂	PM ₁₀	PM _{2.5}
Construction in Calendar Year One	5.66	57.65	53.83	0.10	949.93	96.64
Construction in Calendar Year Two	5.18	30.12	52.46	0.09	949.82	96.54
ICAPCD Significance Threshold	75	100	550	—	150	—
Exceed ICAPCD Significance Threshold?	No	No	No	No	Yes	No

Source: Appendix C of this EIR

Notes: Pounds per day taken from the season with the highest output.

As shown in Table 3.4-7, the project’s daily construction emissions would not exceed the ICAPCD thresholds for ROG, NO_x, CO, SO₂, and PM_{2.5}. However, the project would exceed the ICAPCD threshold for PM₁₀. Pursuant to ICAPCD, all construction sites, regardless of size, must comply with the requirements contained within Regulation VIII – Fugitive Dust Control Measures. The project must comply with the requirements of ICAPCD Regulation VIII for the control of fugitive dust. A predominate source of project PM₁₀ emissions is workers commuting to and from the project site on unpaved roads (worker access and heavy construction equipment access routes described above). Regulation VIII requires all unpaved roadways, on- and off-site, to be conditioned and maintained with soil stabilizers to reduce dust opacity to no more than 20 percent; all unpaved disturbed surfaces, on- and off-site, to be stabilized with a dust suppressant, watering, or soil stabilizers to reduce opacity to no greater than 20 percent; and to reduce vehicle speed to no greater than 15 mph on all unpaved surfaces. Table 3.4-8 shows the project’s emissions with implementation of the Regulation VIII fugitive dust control measures (Mitigation Measure AQ-1). With implementation of Mitigation Measure AQ-1, the project would not exceed the ICAPCD’s thresholds of significance for PM₁₀ emissions.

Table 3.4-8. Project Construction-Generated Emissions – Mitigated

Construction Year	Pollutant (pounds per day)					
	ROG	NO _x	CO	SO ₂	PM ₁₀	PM _{2.5}
Construction in Calendar Year One	5.66	57.61	53.83	0.10	91.86	11.00
Construction in Calendar Year Two	5.18	30.03	52.46	0.09	91.75	10.90
ICAPCD Significance Threshold	75	100	550	—	150	—
Exceed ICAPCD Significance Threshold?	No	No	No	No	No	No

Source: Appendix C of this EIR

In addition, as described in Mitigation Measure AQ-2, construction equipment shall be equipped with an engine designation of EPA Tier 2 or better (Tier 2+). A list of the construction equipment, including all off-road equipment utilized at the project site by make, model, year, horsepower and expected/actual hours of use, and the associated EPA Tier shall be submitted to the County Planning and Development Services Department and ICAPCD prior to the issuance of a grading permit. The equipment list shall be submitted periodically to ICAPCD to perform a NO_x analysis. ICAPCD shall

utilize this list to calculate air emissions to verify that equipment use does not exceed significance thresholds.

Operational Emissions. The proposed project requires minimal operations and maintenance activities conducted by two to three employees. Project-generated increases in emissions would be predominately associated with motor vehicle use for routine maintenance work and site security as well as panel upkeep and cleaning. Long-term operational emissions attributable to the project are identified in Table 3.4-9 and compared to the operational significance thresholds promulgated by the ICAPCD.

Table 3.4-9. Project Operational Emissions

Emission Source	Pollutant (pounds per day)					
	ROG	NO _x	CO	SO ₂	PM ₁₀	PM _{2.5}
Summer Emissions						
Area	13.59	0.00	0.06	0.00	0.00	0.00
Energy	0.26	2.42	2.03	0.01	0.18	0.18
Mobile	0.02	0.03	0.31	0.00	4.84	0.49
Offroad Equipment	1.16	11.09	12.70	0.02	0.56	0.51
Total	15.04	13.55	15.11	0.03	5.59	1.19
ICAPCD Significance Threshold	137	137	150	550	550	150
Exceed ICAPCD Significance Threshold?	No	No	No	No	No	No
Winter Emissions						
Area	13.59	0.00	0.06	0.00	0.00	0.00
Energy	0.26	2.42	2.03	0.01	0.18	0.18
Mobile	0.02	0.03	0.24	0.00	4.84	0.49
Offroad Equipment	1.16	11.09	12.70	0.02	0.56	0.51
Total	15.04	13.55	15.04	0.03	5.59	1.19
ICAPCD Significance Threshold	137	137	150	550	550	150
Exceed ICAPCD Significance Threshold?	No	No	No	No	No	No

Source: Appendix C of this EIR

As shown in Table 3.4-9, the project’s operational emissions would not exceed the ICAPCD thresholds for CO, ROG, NO_x, PM₁₀ and PM_{2.5}. Although no significant air quality impact would occur during operation, the project applicant is required to submit a Dust Suppression Management Plan for both construction and operation in order to reduce fugitive dust emissions. Implementation of Mitigation Measures AQ-1, AQ-3, and AQ-4 would ensure that a Dust Suppression Management Plan is implemented, thereby ensuring that this potential impact would remain less than significant.



As a solar generation facility, the proposed project would improve air quality by reducing the use of fossil fuels in energy production. The energy produced by the project would displace the criteria pollutant emissions which would otherwise be produced by existing business-as-usual power generation resources (including natural gas and coal). Table 3.4-10 shows the emissions that would potentially be displaced by the proposed project. Displacement of fossil fuel emissions has a direct beneficial effect on human health for those receptors downwind of the location of the fossil fuel power plants. As shown, the project would potentially displace approximately 483 tons of NO_x, 37 tons of CO, 64 tons of SO₂, 64 tons of PM₁₀, and 27 tons of PM_{2.5} over the course of 30 years.

Table 3.4-10. Proposed Project Displaced Criteria Pollutant Emissions (Tons)

Source of Displaced Emissions	Emissions (tons)					
	ROG	NO _x	CO	SO ₂	PM ₁₀	PM _{2.5}
Emissions Displaced Annually (tons)						
Displaced Natural Gas-Source Emissions	0	2.14	0.65	1.47	2.03	0.82
Displaced Coal-Source Emissions	0	13.97	0.58	0.66	0.10	0.07
Total	0	16.11	1.23	2.13	2.13	0.89
Emissions Displaced over 30 Years (tons)						
Total	0	483.37	36.93	64.03	63.93	26.75

Source: Appendix C of this EIR

Note: Note that this estimate only includes that associated with the combustion of fossil fuels; it does not include the vehicle trips associated with the project's operations, and it similarly does not include operational employee trips associated with natural gas or coal combustion nor the emissions associated with extracting and transporting those power sources. In addition, this estimate only includes the displacement of that portion of the California market that comes from fossil fuels and does not include the approximate 50 percent of the California electricity generated by non-combustion sources (wind, solar, nuclear, hydro-electric) (See Appendix C for details).

As described above, conformance with the AQMP for development projects is determined by demonstrating compliance with local land use plans and/or population projections and comparing assumed emissions in the AQMP to proposed emissions. Because the proposed project complies with local land use plans and population projections and would not exceed ICAPCD's regional mass daily emissions thresholds during construction (with implementation of Mitigation Measure AQ-1) and operation, the proposed project would not conflict with or obstruct implementation of the applicable air quality plan. Furthermore, the project would also have a direct beneficial effect on human health by displacing criteria pollutants. Impacts would be less than significant impact with mitigation incorporated.

Mitigation Measure(s)

AQ-1 Fugitive Dust Control. During construction activities, the constructor contractor shall employ the following PM₁₀ reducing measures:

1. All unpaved roads associated with construction shall be effectively stabilized of dust emissions using Imperial County Air Pollution Control District-approved chemical stabilizers/suppressant before the commencement of construction, and every 30 days thereafter until the end of all construction activities. Unpaved roads associated with construction include:
 - The driveway entrance off State Route 98,

- The project designated 3.5-acre staging/parking area north of the All-American Canal,
- The 1.0 mile of dirt road south of the All-American Canal,
- The 20 miles of existing dirt road paralleling the U.S./Mexico Border from Gordon Wells Road to the project site.

Monthly application of Imperial County Air Pollution Control District-approved chemical stabilizers/suppressant shall be applied at a rate of 0.1 gallon/ square yard of chemical dust suppressant.

2. Prior to any earthmoving activity, the applicant shall submit a construction dust control plan and obtain Imperial County Air Pollution Control District and Imperial County Planning and Development Services Department (ICPDS) approval.
3. Pursuant to ICAPCD, all construction sites, regardless of size, must comply with the requirements contained within Regulation VIII – Fugitive Dust Control Measures. Whereas these Regulation VIII measures are mandatory and are not considered project environmental mitigation measures, the ICAPCD CEQA Handbook’s required additional standard and enhanced mitigation measures listed below shall be implemented prior to and during construction. ICAPCD will verify implementation and compliance with these measures as part of the grading permit review/approval process.

ICAPCD Standard Measures for Fugitive Dust (PM₁₀) Control

- All disturbed areas, including bulk material storage, which is not being actively utilized, shall be effectively stabilized and visible emissions shall be limited to no greater than 20 percent opacity for dust emissions by using water, chemical stabilizers, dust suppressants, tarps, or other suitable material, such as vegetative ground cover.
- All on-site and off-site unpaved roads will be effectively stabilized, and visible emissions shall be limited to no greater than 20 percent opacity for dust emissions by paving, chemical stabilizers, dust suppressants, and/or watering.
- All unpaved traffic areas 1 acre or more with 75 or more average vehicle trips per day will be effectively stabilized and visible emissions shall be limited to no greater than 20 percent opacity for dust emissions by paving, chemical stabilizers, dust suppressants, and/or watering.
- The transport of bulk materials shall be completely covered unless 6 inches of freeboard space from the top of the container is maintained with no spillage and loss of bulk material. In addition, the cargo compartment of all haul trucks is to be cleaned and/or washed at delivery site after removal of bulk material.
- All track-out or carry-out will be cleaned at the end of each workday or immediately when mud or dirt extends a cumulative distance of 50 linear feet or more onto a paved road within an urban area.
- Movement of bulk material handling or transfer shall be stabilized prior to handling or at points of transfer with application of sufficient water, chemical stabilizers, or by sheltering or enclosing the operation and transfer line.

- The construction of any new unpaved road is prohibited within any area with a population of 500 or more unless the road meets the definition of a temporary unpaved road. Any temporary unpaved road shall be effectively stabilized, and visible emissions shall be limited to no greater than 20 percent opacity for dust emission by paving, chemical stabilizers, dust suppressants, and/or watering.

ICAPCD “Discretionary” Measures for Fugitive Dust (PM₁₀) Control

- Water exposed soil only in those areas where active grading and vehicle movement occurs with adequate frequency to control dust.
- Replace ground cover in disturbed areas as quickly as possible.
- Automatic sprinkler system installed on all soil piles.
- Vehicle speed for all construction vehicles shall not exceed 15 miles per hour on any unpaved surface at the construction site.
- Develop a trip reduction plan to achieve a 1.5 average vehicle ridership for construction employees.
- Implement a shuttle service to and from retail services and food establishments during lunch hours.

Standard Mitigation Measures for Construction Combustion Equipment

- Use of alternative fueled or catalyst equipped diesel construction equipment, including all off-road and portable diesel-powered equipment.
- Minimize idling time either by shutting equipment off when not in use or reducing the time of idling to 5 minutes as a maximum.
- Limit, to the extent feasible, the hours of operation of heavy-duty equipment and/or the amount of equipment in use.
- Replace fossil fueled equipment with electrically driven equivalents (provided they are not run via a portable generator set).

Enhanced Mitigation Measures for Construction Equipment

To help provide a greater degree of reduction of PM emissions from construction combustion equipment, ICAPCD recommends the following enhanced measures.

- Curtail construction during periods of high ambient pollutant concentrations; this may include ceasing of construction activity during the peak hour of vehicular traffic on adjacent roadways.
- Implement activity management (e.g., rescheduling activities to reduce short-term impacts).

AQ-2

Construction Equipment. Construction equipment shall be equipped with an engine designation of EPA Tier 2 or better (Tier 2+). A list of the construction equipment, including all off-road equipment utilized at the project site by make, model, year, horsepower and expected/actual hours of use, and the associated EPA Tier shall be submitted to the County Planning and Development Services Department and ICAPCD prior to the issuance of a grading permit. The equipment list shall be submitted periodically to ICAPCD to perform a NO_x analysis. ICAPCD shall utilize this

list to calculate air emissions to verify that equipment use does not exceed significance thresholds. The Planning and Development Services Department and ICAPCD shall verify implementation of this measure.

AQ-3 Dust Suppression. The project applicant shall employ a method of dust suppression (such as water or chemical stabilization) approved by ICAPCD. The project applicant shall apply chemical stabilization as directed by the product manufacturer to control dust between the panels as approved by ICAPCD, and other non-used areas (exceptions will be the paved entrance and parking area, and Fire Department access/emergency entry/exit points as approved by Fire/Office of Emergency Services [OES] Department).

AQ-4 Operational Dust Control Plan. Prior to issuance of a Certificate of Occupancy, the applicant shall submit an operations dust control plan and obtain ICAPCD and ICPDS approval.

ICAPCD Rule 301 Operational Fees apply to any project applying for a building permit. At the time that building permits are submitted for the proposed project, ICAPCD shall review the project to determine if Rule 310 fees are applicable to the project.

Significance After Mitigation

With implementation of the Regulation VIII fugitive dust control measures (Mitigation Measure AQ-1), the project would not exceed the ICAPCD's thresholds of significance for PM₁₀ emissions. Mitigation Measures AQ-2 through AQ-4 would provide additional reduction strategies to further improve air quality and reductions in criteria pollutants (O₃ precursors) and ensure that this potential impact would remain less than significant. Given the above, the proposed project would not conflict with implementation of applicable air quality plans, and impacts would be less than significant impact.

Impact 3.4-2 Would the project result in a cumulatively considerable net increase of any criteria pollutant for which the project region is non-attainment under an applicable federal or state ambient air quality standard (including releasing emissions which exceed quantitative thresholds for O₃ precursors)?

As shown in Table 3.4-2, the criteria pollutants for which the project area is in State non-attainment under applicable air quality standards are O₃ and PM₁₀. The ICAPCD's application of thresholds of significance for criteria air pollutants is relevant to the determination of whether a project's individual emissions would have a cumulatively significant impact on air quality. As discussed above in Impact 3.4-1, the project's daily construction emissions would not exceed the ICAPCD thresholds for ROG, NO_x, CO, SO₂, and PM_{2.5}. However, the project would exceed the ICAPCD threshold for PM₁₀. To mitigate the potential impacts associated with construction-generated emissions with regard to PM₁₀, the project would adhere to the requirements of ICAPCD Regulation VIII for the control of fugitive dust. As shown in Table 3.4-8, the project's emissions with implementation of the Regulation VIII fugitive dust control measures, the project would not exceed the ICAPCD's threshold of significance for PM₁₀ emissions. Furthermore, implementation of Mitigation Measures AQ-1 through AQ-5 will ensure compliance with ICAPCD rules and regulations and applicable air quality plan control measures. Therefore, the project's potential to result in a cumulatively considerable net increase of any criteria pollutant is considered less than significant.

Mitigation Measure(s)

No mitigation measures are required.

Impact 3.4-3 Would the project expose sensitive receptors to substantial pollutant concentrations?

The project site is in a generally rural area and surrounded by undeveloped land, portions of which have been disturbed associated with previous agricultural-related activities to the west and east, the All-American Canal running southwest on the northern border of the project site, and the U.S./Mexico international border to the south. The nearest sensitive receptor to the project site is a single-family residence located to the northeast, approximately 0.5 miles from the northeastern corner of the project site.

Construction-Generated Air Contaminants. Construction of the project would result in temporary, short-term project-generated emissions of DPM, ROG, NO_x, CO, and PM₁₀ from the exhaust of off-road, heavy-duty diesel equipment; soil hauling truck traffic; paving; and other miscellaneous activities. The portion of the SSAB which encompasses the project area is designated as a nonattainment area for federal O₃, PM_{2.5} and PM₁₀ standards and is also a nonattainment area for the state standards for O₃ and PM₁₀. Thus, existing O₃ and PM₁₀ levels in the SSAB are at unhealthy levels during certain periods. However, as shown in Table 3.4-7, the project would exceed the ICAPCD's significance threshold for PM₁₀. As previously described above, with implementation of the Regulation VIII fugitive dust control measures (Mitigation Measure AQ-1), the project would not exceed the ICAPCD's thresholds of significance for PM₁₀ emissions. The health effects associated with O₃ are generally associated with reduced lung function. Because the project would not involve construction activities that would result in O₃ precursor emissions (ROG or NO_x) in excess of the ICAPCD thresholds, the project is not anticipated to substantially contribute to regional O₃ concentrations and the associated health impacts.

CO tends to be a localized impact associated with congested intersections. In terms of adverse health effects, CO competes with oxygen, often replacing it in the blood, reducing the blood's ability to transport oxygen to vital organs. The results of excess CO exposure can include dizziness, fatigue, and impairment of central nervous system functions. The project would not involve activities that would result in CO emissions in excess of the ICAPCD thresholds. Thus, the project's CO emissions would not contribute to the health effects associated with this pollutant.

Particulate matter (PM₁₀ and PM_{2.5}) contains microscopic solids or liquid droplets that are so small that they can get deep into the lungs and cause serious health problems. Particulate matter exposure has been linked to a variety of problems, including premature death in people with heart or lung disease, nonfatal heart attacks, irregular heartbeat, aggravated asthma, decreased lung function, and increased respiratory symptoms such as irritation of the airways, coughing, or difficulty breathing. For construction-type activity, DPM is the primary TAC of concern. PM₁₀ exhaust is considered a surrogate for DPM as all diesel exhaust is considered to be DPM. Most PM₁₀ exhaust derives from combustion, such as use of gasoline and diesel fuels by motor vehicles. As with O₃ and NO_x, the project would not generate emissions of PM₁₀ or PM_{2.5} that would exceed the ICAPCD's thresholds. Accordingly, the project's PM₁₀ and PM_{2.5} emissions are not expected to cause any increase in related regional health effects for these pollutants.

Operational Air Contaminants. Operation of the proposed project would not result in the development of any substantial sources of air toxics. There would be no stationary sources associated project operations; nor would the project attract additional mobile sources that spend long periods

queuing and idling at the site. Onsite project emissions would not result in significant concentrations of pollutants at nearby sensitive receptors as the predominant operational emissions associated with the proposed project would be routine maintenance work, water deliveries, and site security as well as panel upkeep and cleaning. Therefore, the project would not be a substantial source of TACs. The proposed project would not result in a high carcinogenic or non-carcinogenic risk during operation.

CO concentrations close to congested intersections that experience high levels of traffic and elevated background concentrations may reach unhealthy levels, affecting nearby sensitive receptors. Given the high traffic volume potential, areas of high CO concentrations, or “hot spots,” are typically associated with intersections that are projected to operate at unacceptable levels of service during the peak commute hours. CO concentration in the SSAB is designated as an attainment area. Detailed modeling of Project-specific CO “hot spots” is not necessary and thus this potential impact is addressed qualitatively.

The proposed project is anticipated to result in no more than 6 daily traffic trips. It is noted that this is a conservative estimate, and many days will have no operational related vehicle trips. Thus, the proposed project would not generate traffic volumes at any intersection of more than 100,000 vehicles per day (or 44,000 vehicles per day) and there is no likelihood of the project traffic exceeding CO values.

In summary, project construction and operations would not result in a potentially significant contribution to regional concentrations of nonattainment pollutants and would not result in a significant contribution to the adverse health impacts associated with those pollutants. Additionally, given that the nearest sensitive receptor is approximately 0.5 miles from the northeastern corner of the project site, implementation of the project would not expose sensitive receptors to substantial pollutant concentrations, and impacts would be less than significant.

Mitigation Measure(s)

No mitigation measures are required.

Impact 3.4-4 Would the project result in other emissions (such as those leading to odors) adversely affecting a substantial number of people?

An odor impact depends on numerous factors, including the nature, frequency, and intensity of the source; wind speed and direction; and the sensitivity of the receptors. While offensive odors rarely cause any physical harm, they still can be very unpleasant, leading to considerable distress among the public and often generating citizen complaints to local governments and regulatory agencies.

Among possible physical harms is inhalation of VOCs that cause smell sensations in humans. These odors can affect human health in four primary ways:

- The VOCs can produce toxicological effects
- The odorant compounds can cause irritations in the eye, nose, and throat
- The VOCs can stimulate sensory nerves that can cause potentially harmful health effects
- The exposure to perceived unpleasant odors can stimulate negative cognitive and emotional responses based on previous experiences with such odors

Land uses commonly considered to be potential sources of odorous emissions include wastewater treatment plants, sanitary landfills, food processing facilities, chemical manufacturing plants, rendering

plants, paint/coating operations, and concentrated agricultural feeding operations and dairies. The construction and operation of a solar farm is not an odor producer.

During construction, the proposed project presents the potential for generation of objectionable odors in the form of diesel exhaust in the immediate vicinity of the site. However, these emissions are short-term in nature and will rapidly dissipate and be diluted by the atmosphere downwind of the emission sources. Additionally, odors would be localized and generally confined to the project area. Therefore, odors generated during project construction would not adversely affect a substantial number of people to odor emissions. No impact would occur.

Mitigation Measure(s)

No mitigation measures are required.

3.4.4 Decommissioning/Restoration and Residual Impacts

Decommissioning/Restoration

If at the end of the PPA term, no contract extension is available for a power purchaser, no other buyer of the energy emerges, or there is no further funding of the project, the project will be decommissioned and dismantled. Similar to construction activities, decommissioning and restoration of the project site would generate air emissions. A summary of the daily construction emissions for the project is provided in Table 3.4-7. Solar equipment has a lifespan of approximately 20 to 25 years. The emissions from on- and off-road equipment during decommissioning are expected to be significantly lower than project construction emissions, as the overall activity would be anticipated to be lower than project construction activity. No significant air quality impacts are anticipated during decommissioning and restoration of the project site. However, all construction projects within Imperial County must comply with the requirements of ICAPCD Regulation VIII for the control of fugitive dust. In addition, the ICAPCD's Air Quality Handbook lists additional feasible mitigation measures that may be warranted to control emissions of fugitive dust and combustion exhaust. Mitigation Measures AQ-1 through AQ-4 would provide additional reduction strategies to further improve air quality. Therefore, a less than significant impact is identified during decommissioning and site restoration of the project site.

Residual

The proposed project's daily construction emissions would not exceed the ICAPCD's thresholds for ROG, NO_x, CO, SO₂, and PM_{2.5}. However, the project would exceed the ICAPCD's threshold for PM₁₀. To mitigate the potential impacts associated with construction-generated emissions with regard to PM₁₀, the project would adhere to the requirements of ICAPCD Regulation VIII for the control of fugitive dust (Mitigation Measure AQ-1). Thus, the proposed project would not result in short-term significant air quality impacts during construction. Furthermore, implementation of Mitigation Measure AQ-2 would ensure construction equipment will be equipped with an engine designation of EPA Tier 2 or better (Tier 2+). ICAPCD will utilize this list to calculate air emissions to verify that equipment use does not exceed significance thresholds. Operation of the project, subject to the approval of a CUP, would be consistent with applicable federal, state, regional, and local plans and policies. Implementation of Mitigation Measures AQ-1, AQ-3, and AQ-4 would ensure that fugitive dust emissions would be reduced during construction and operations. The project would not result in any residual operational significant and unavoidable impacts with regards to air quality.

This page is intentionally blank.

3.5 Biological Resources

This section identifies the biological resources that may be impacted by the proposed project. The following identifies the existing biological resources on the project site, analyzes potential impacts of the proposed project, and recommends mitigation measures to avoid or reduce potential impacts of the proposed project.

The existing biological resources information for this section is summarized from the following technical reports:

- *Biological Resources Technical Report* (BRTR) prepared by ECORP Consulting Inc. (Appendix D of this EIR)
- *Aquatic Resources Delineation Report* prepared by ECORP Consulting Inc. (Appendix E of this EIR)

As part of the *Biological Resources Technical Report*, ECORP Consulting Inc. conducted a literature review, small unmanned aircraft system survey, and biological reconnaissance survey of the project site to document the existing biological resources, to assess the habitat for its potential to support sensitive plant and wildlife species, and to determine the potential impacts of the project on biological resources.

For the purposes of this EIR, the term biological study area (BSA) refers to the project footprint, a 500-foot buffer, and areas subject to temporary impacts.

The *Aquatic Resources Delineation Report* identifies the aquatic resources occurring within the project site that may be regulated by the Porter-Cologne Water Quality Act, California Fish and Game Code Sections 1600 and 1602, and the U.S. Army Corps of Engineers (USACE) pursuant to Sections 401 and 404 of the federal Clean Water Act (CWA).

3.5.1 Existing Conditions

The project site consists of undeveloped land that appears to have been historically altered for agricultural purposes. Specifically, the disturbed nature of the site, including flora composition, old agricultural foundations, and farming equipment including a center-pivot irrigation system, indicates that portions of the land may have been historically used for agricultural production. The eastern portion of the site consists primarily of creosote bush scrub with bordering riparian scrub and wetland habitats to the northern edge and western section. The project site is surrounded to the north and southwest by agricultural fields, and undeveloped land to the east and southeast. The All-American Canal is just north of the site and the U.S./Mexico border is located just south of the site.

Vegetation Communities and Land Cover Types

The majority of vegetation communities and land cover types mapped within the BSA consists of creosote bush – white bursage scrub (disturbed), disturbed land, and tamarisk thickets. Vegetation communities and land cover types within the BSA are depicted on Figure 3.5-1 through Figure 3.5-9 and summarized in Table 3.5-1.

Table 3.5-1. Vegetation Communities or Land Cover Types within the BSA

Vegetation Community or Land Cover Type	Acres within BSA ^a
Arrow Weed Thickets (disturbed)	10.41
Creosote Bush Scrub	9.45
Creosote Bush – White Bursage Scrub (disturbed)	181.56
Disturbed	159.73
Tamarisk Thickets	66.28
Urban/Developed	0.75
Urban/Developed Roads	73.37
Total	501.55

Source: Appendix D of this EIR

^a Vegetation and land cover type acreages are rounded to the nearest hundredth acre.

*Disturbed Arrow Weed Thickets (Disturbed *Pluchea sericea* Shrubland Alliance)*

Disturbed arrow weed thickets are arrow weed thickets that has been previously altered. On the project site, this vegetation cover is characterized as sparser. Other plant species observed included alkali goldenbush (*Isocoma acradenia*).

*Creosote Bush Scrub (*Larrea tridentata* Shrubland Alliance)*

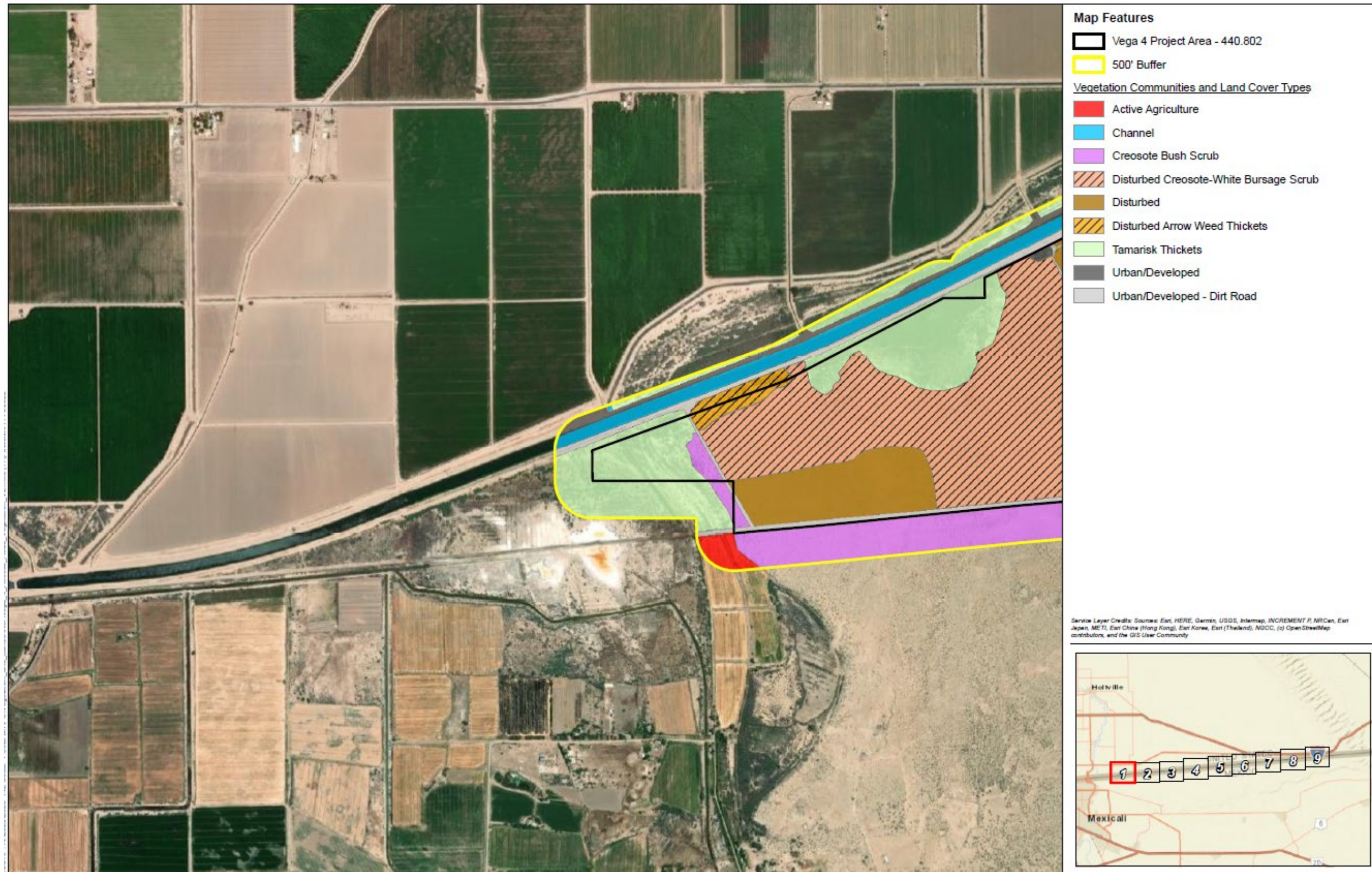
Creosote bush scrub is the most characteristic vegetation of the California desert and is found on alluvial fans, bajadas, upland slopes, and washes. Creosote bush scrub is dominated by a nearly monotypic stand of creosote bush with an open canopy and an herbaceous layer of seasonal annuals and perennials. Other species that occurred on the project site included burrowbush (*Ambrosia dumosa*), apricot mallow (*Sphaeralcea ambigua*), and fanleaf crinkleemat (*Tiquilia plicata*).

*Disturbed Creosote Bush – White Bursage Scrub (Disturbed *Larrea tridentata* – *Ambrosia dumosa* Shrubland Alliance)*

Disturbed creosote bush (i.e., white bursage scrub and white bursage scrub that has been previously altered) are co-dominant in the shrub canopy with an absent to intermittent herbaceous layer of seasonal annuals. On the project site, this vegetation cover is characterized as sparser with a high percentage of non-native plant species including common Mediterranean grass (*Schismus barbatus*) and Saharan mustard (*Brassica tournefortii*). Other plant species include dyebush (*Psoralea argemone*) and crinkleemat.

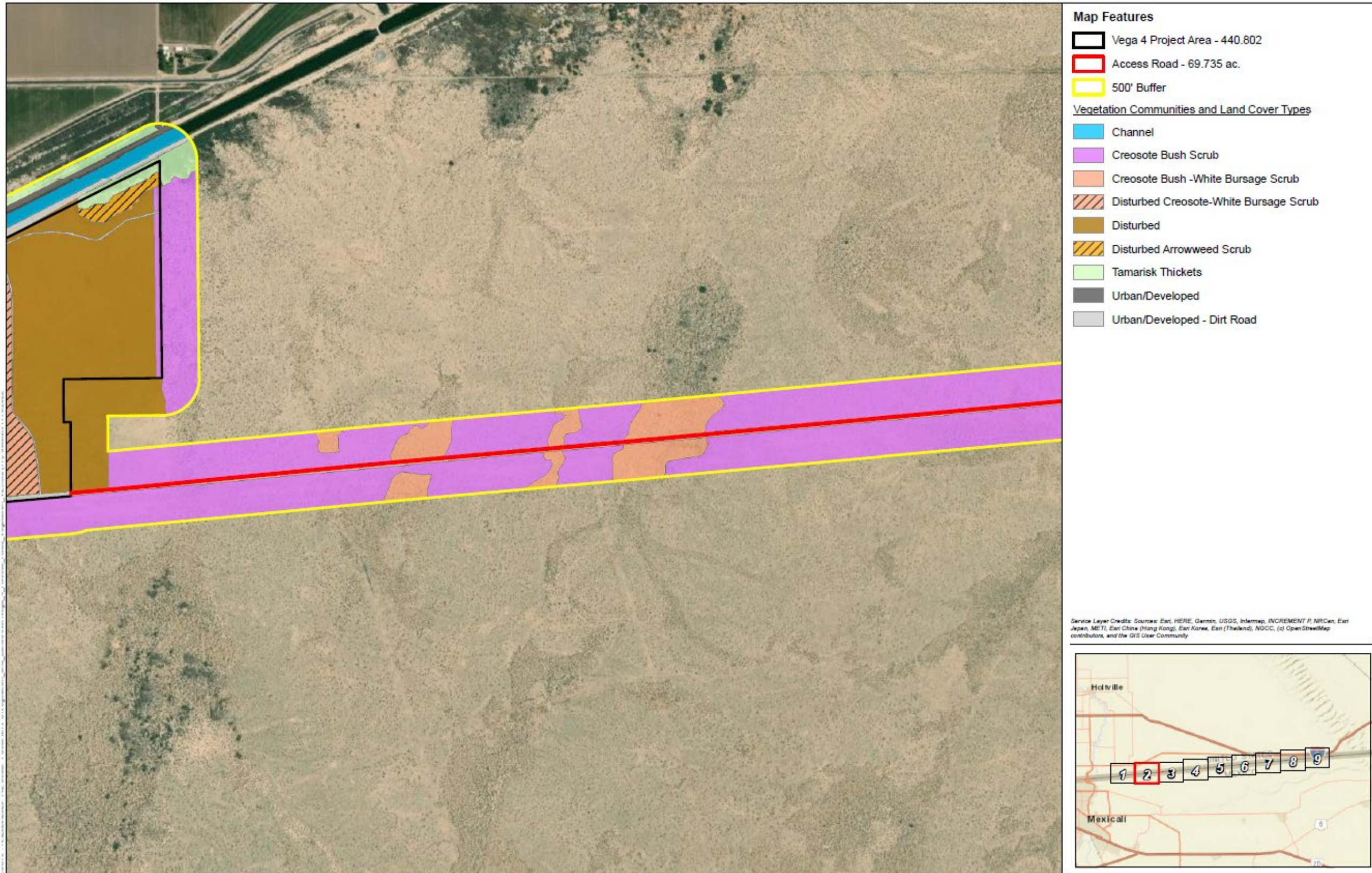


Figure 3.5-1. Vegetation Communities and Land Cover Types in the BSA (Sheet 1 of 9)



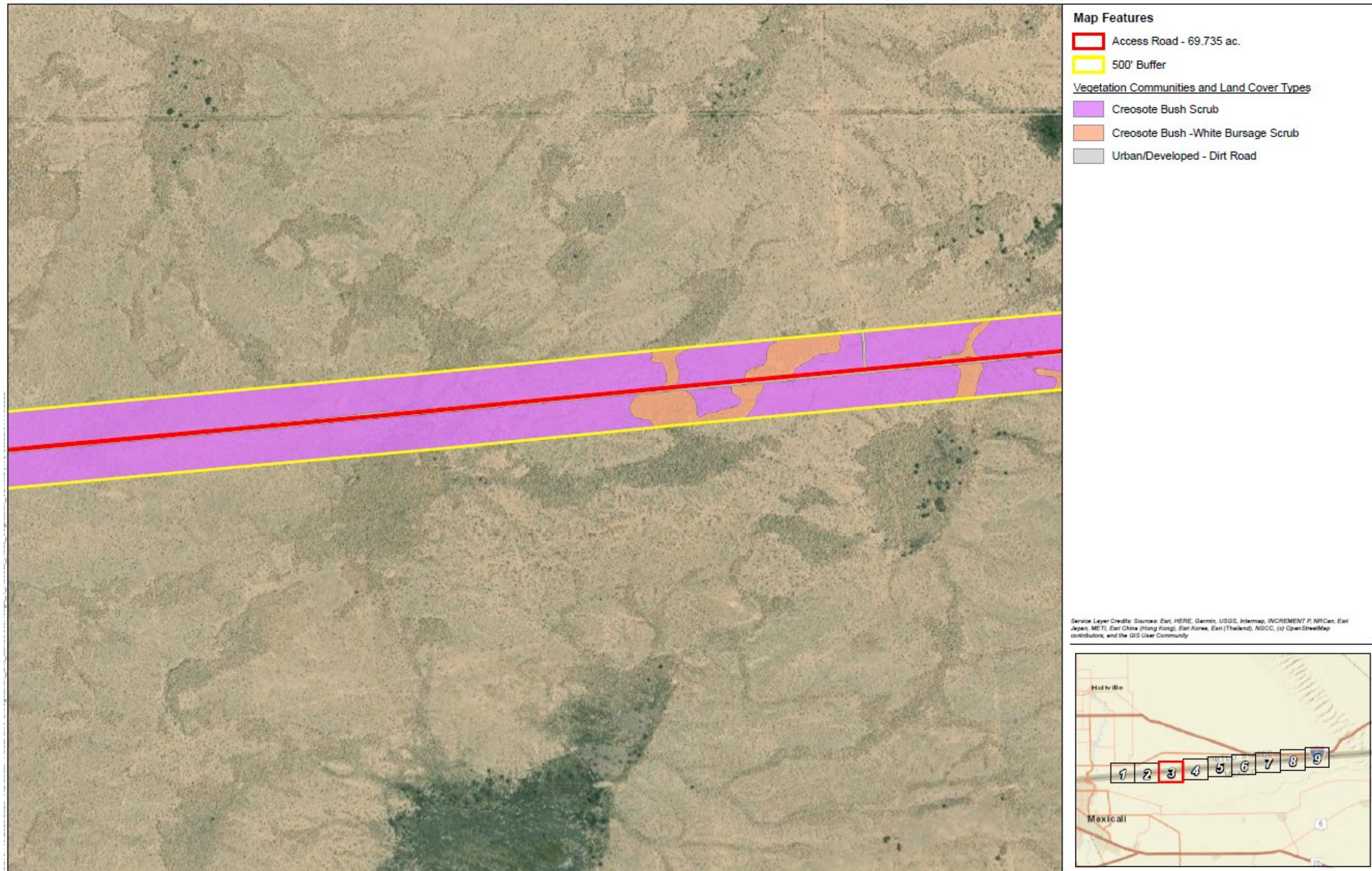
Source: Appendix D of this EIR

Figure 3.5-2. Vegetation Communities and Land Cover Types in the BSA (Sheet 2 of 9)



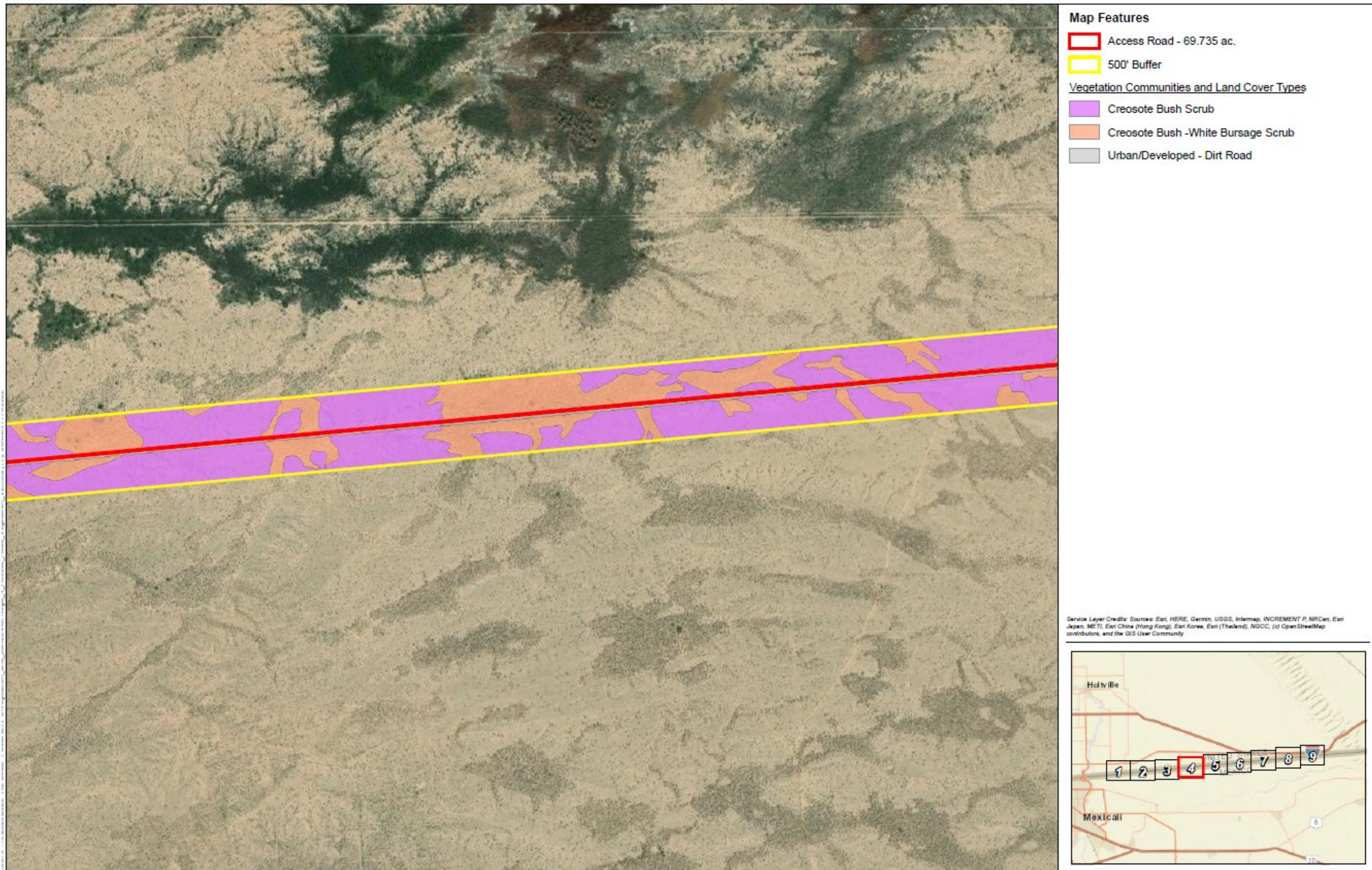
Source: Appendix D of this EIR

Figure 3.5-3. Vegetation Communities and Land Cover Types in the BSA (Sheet 3 of 9)



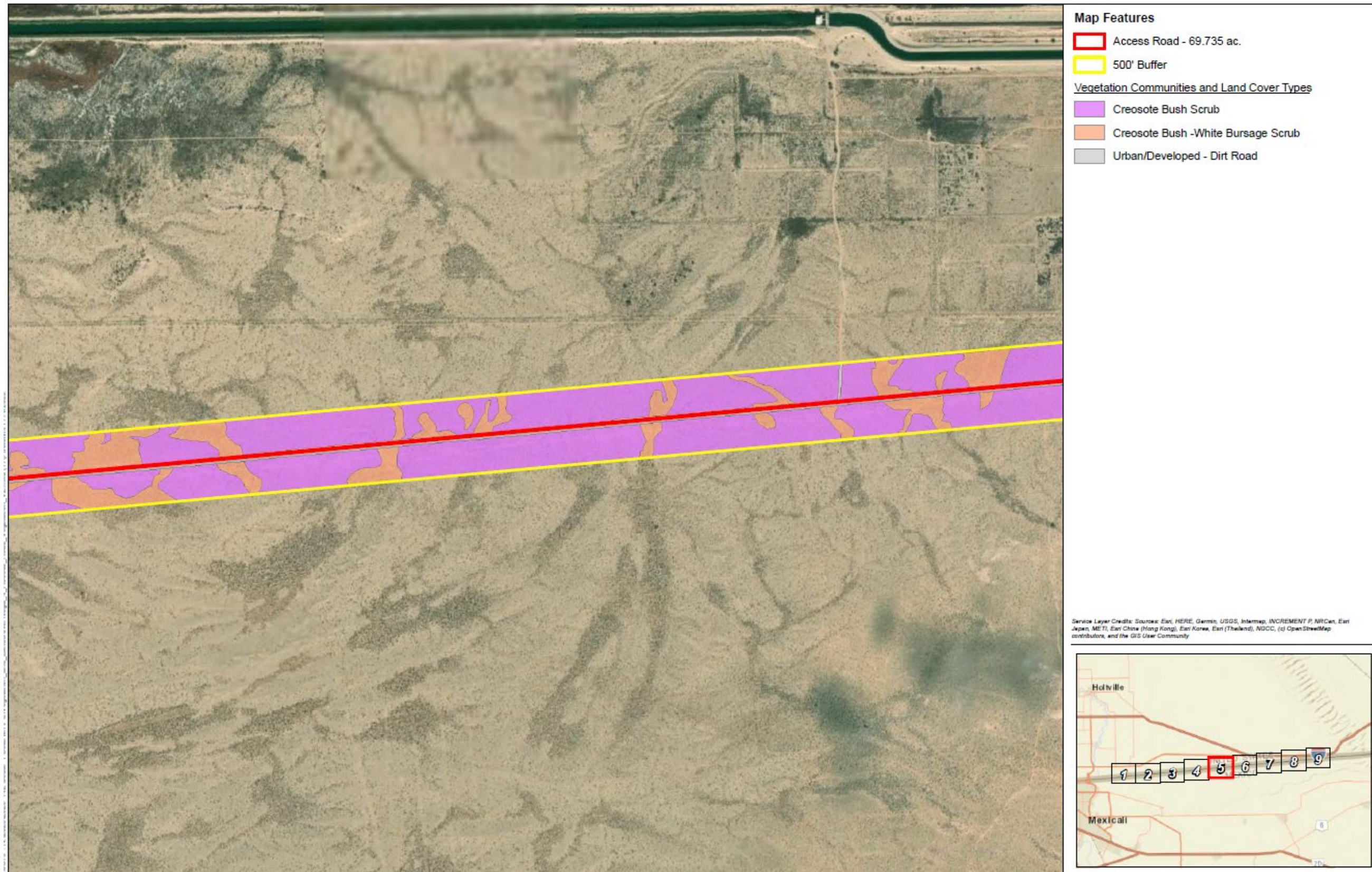
Source: Appendix D of this EIR

Figure 3.5-4. Vegetation Communities and Land Cover Types in the BSA (Sheet 4 of 9)



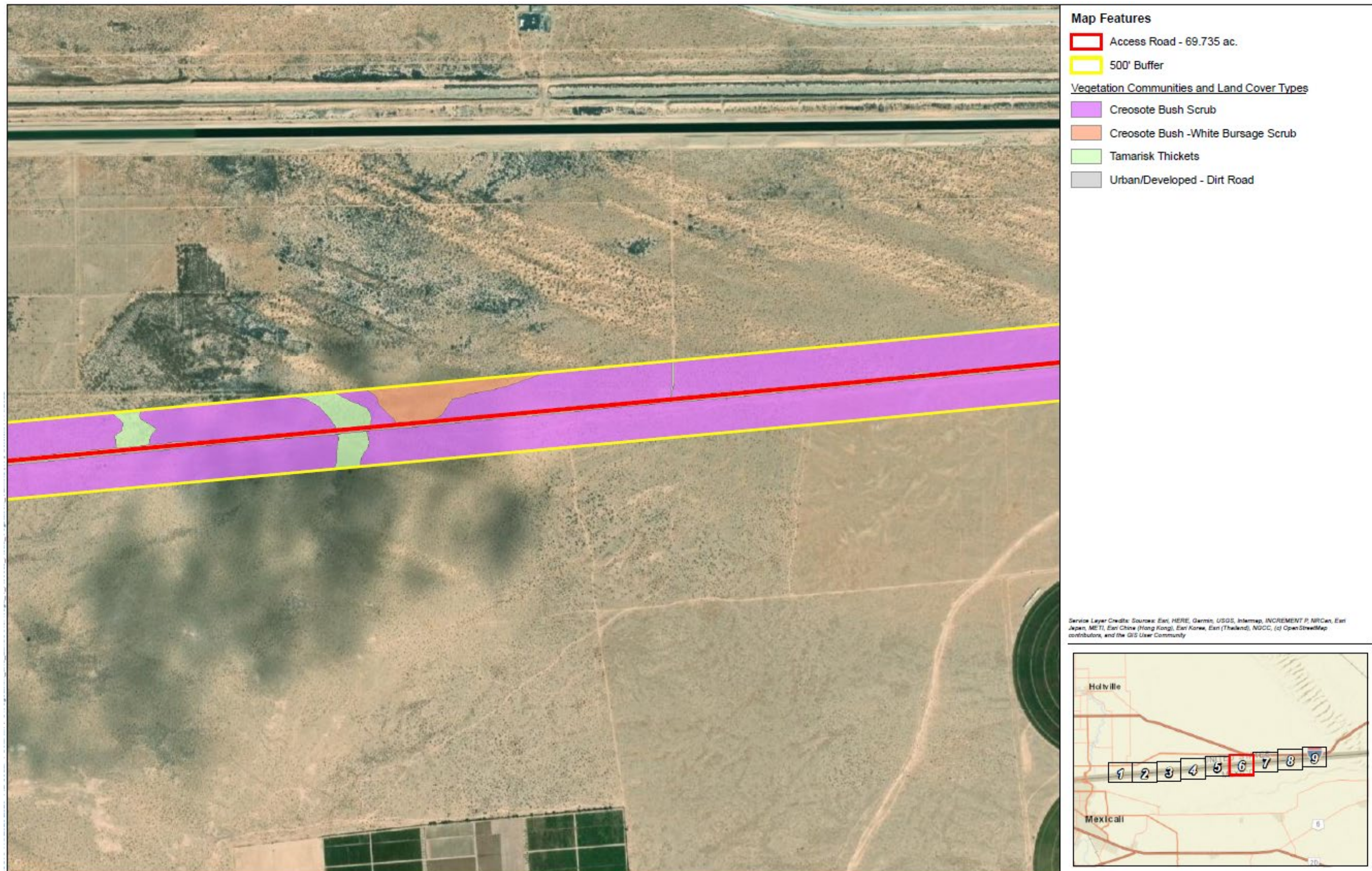
Source: Appendix D of this EIR

Figure 3.5-5. Vegetation Communities and Land Cover Types in the BSA (Sheet 5 of 9)



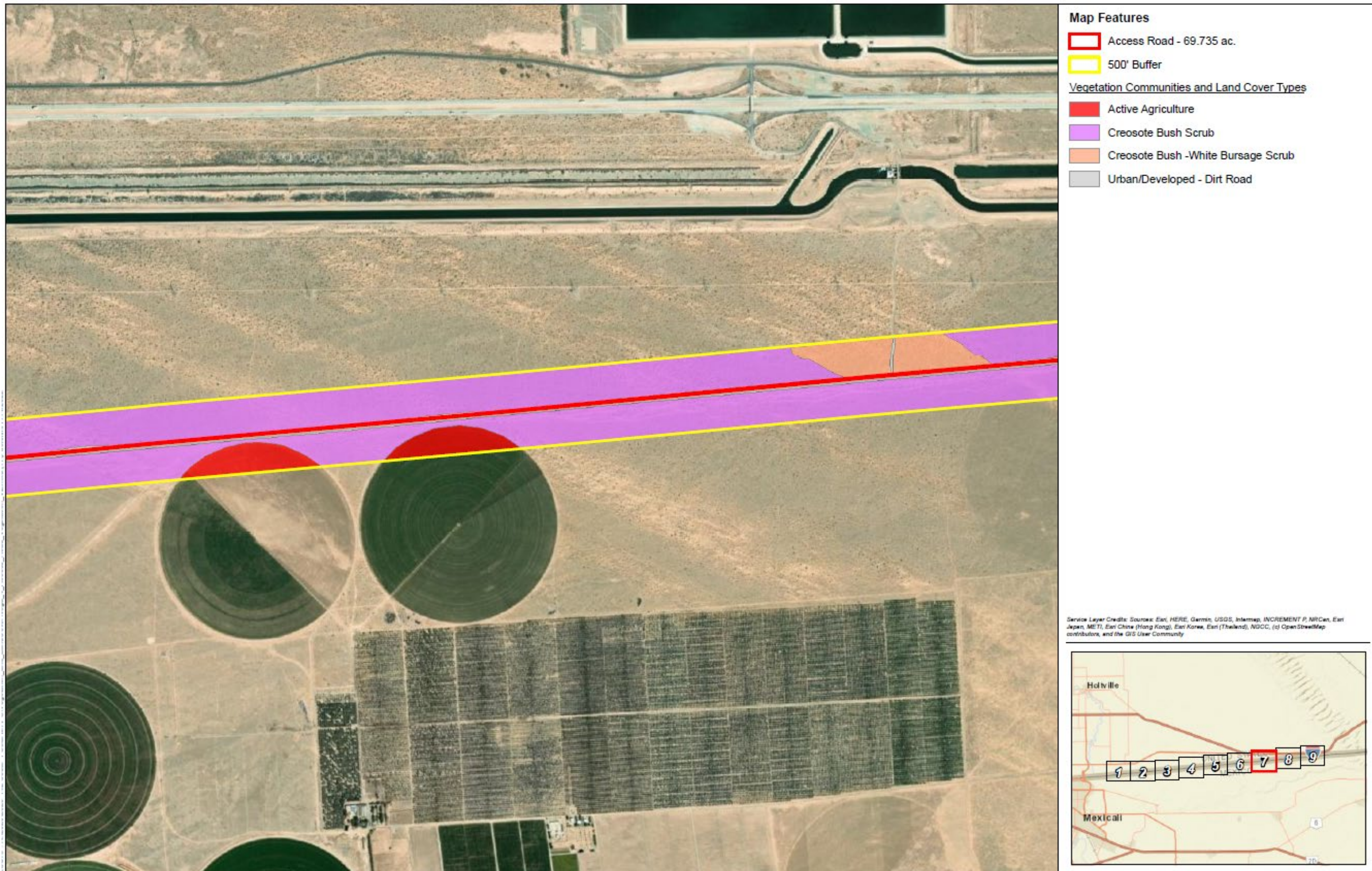
Source: Appendix D of this EIR

Figure 3.5-6. Vegetation Communities and Land Cover Types in the BSA (Sheet 6 of 9)



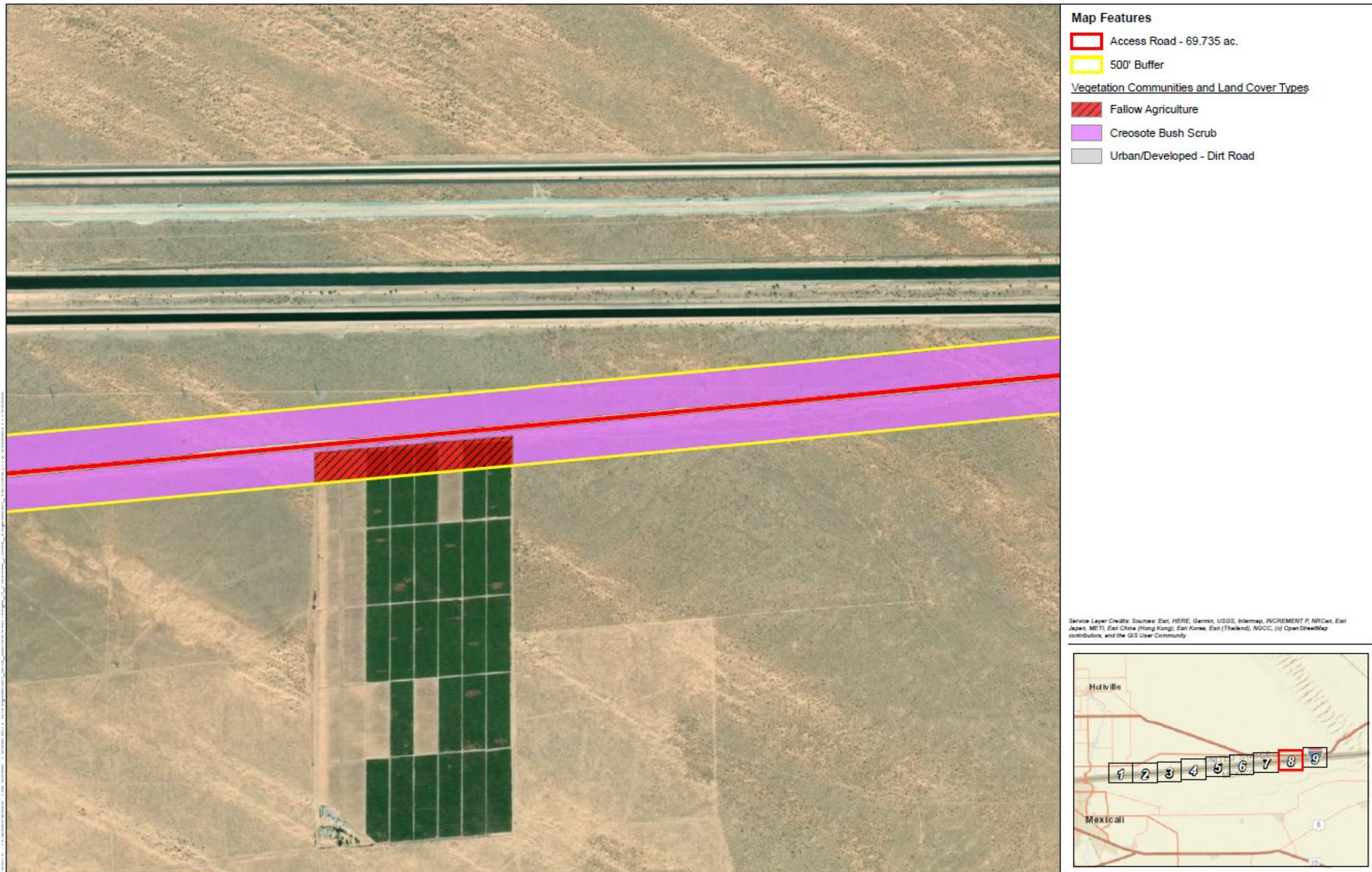
Source: Appendix D of this EIR

Figure 3.5-7. Vegetation Communities and Land Cover Types in the BSA (Sheet 7 of 9)



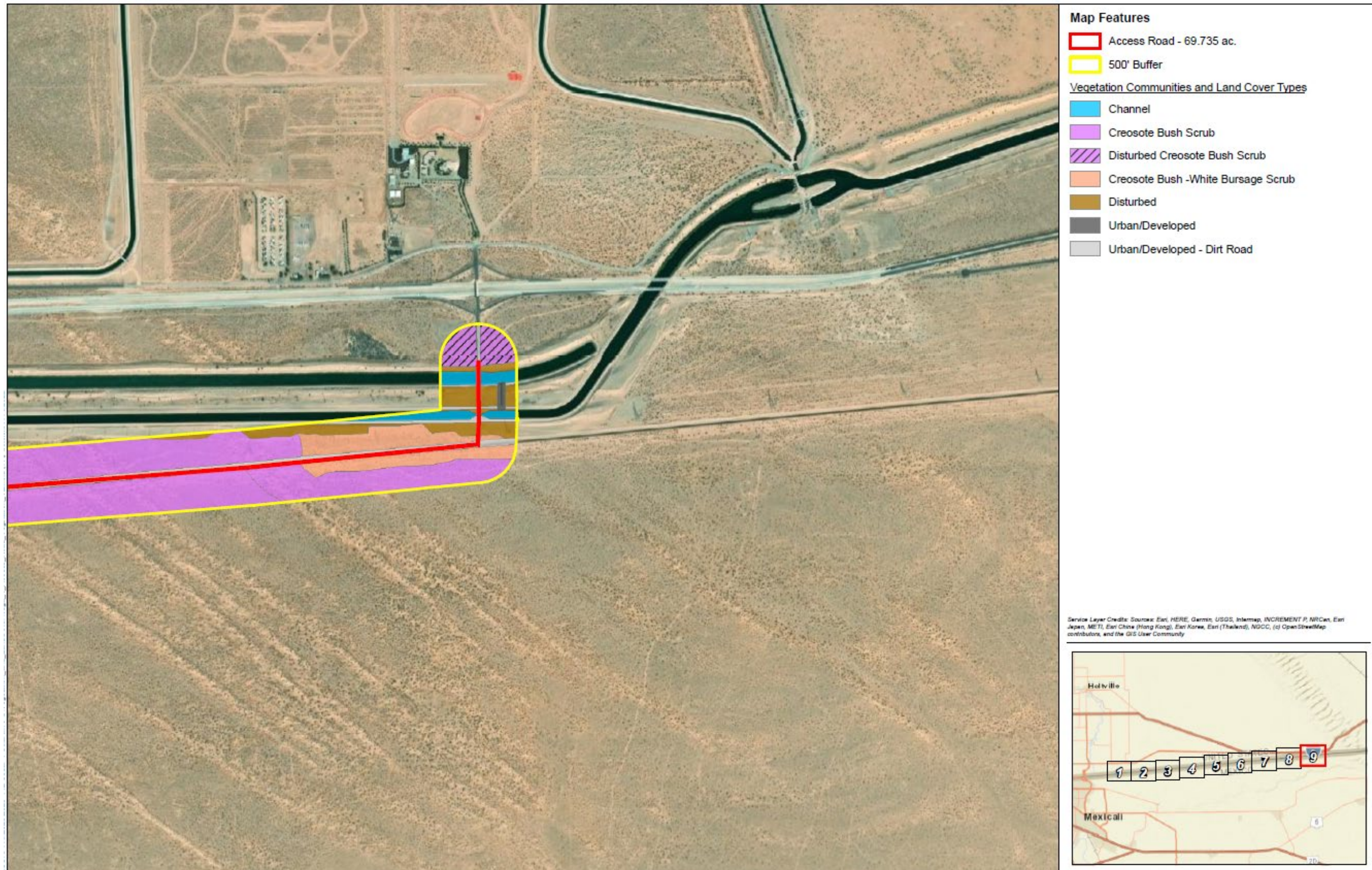
Source: Appendix D of this EIR

Figure 3.5-8. Vegetation Communities and Land Cover Types in the BSA (Sheet 8 of 9)



Source: Appendix D of this EIR

Figure 3.5-9. Vegetation Communities and Land Cover Types in the BSA (Sheet 9 of 9)



Source: Appendix D of this EIR

This page is intentionally blank.

Tamarisk Thickets (Tamarix spp. Shrubland Semi-Natural Alliance)

Tamarisk thickets are characterized by a weedy monoculture of tamarisk. This habitat is typically in ditches, washes, rivers, arroyo margins, lake margins, and other watercourses. On the project site, tamarisk and arrow weed were often co-dominant in this vegetation community. Other plant species observed included cattails (*Typha spp.*), screw bean mesquite (*Prosopis pubescens*), and willow baccharis.

Other Land Cover Types

DISTURBED

Disturbed land includes areas where the native vegetation community has been heavily influenced by human actions, such as grading, trash dumping, and OHV use, but lack development. Disturbed land is not a vegetation classification, but rather a land cover type that is not restricted by elevation. On the project site, the areas consisted primarily of bare ground and Mediterranean grass. Other plant species observed on site included dyebush and white bursage.

URBAN/DEVELOPED

Urban/Developed areas do not constitute a vegetation classification, but rather a land cover type. Areas mapped as developed have been constructed upon or otherwise physically altered to an extent that natural vegetation communities are no longer supported. There may be irrigated landscaped, ornamental species present between the hardscape. On the project site, this land cover was dominant and consisted primarily of compacted dirt roads, structures, and landscape trees including Mexican fan palm (*Washingtonia robusta*) and Mexican palo verde (*Parkinsonia aculeata*). The entirety of the access road is this land cover type.

Sensitive Natural Communities

Tamarisk thicket occurs within the project site and is considered a sensitive natural community by CDFW.

Special-Status Species

Literature Review

Prior to conducting field surveys, a literature search was conducted to identify special-status plant and animal species with potential to occur within the project BSA. The literature review resulted in 14 special-status plant and 21 special-status wildlife species that have historically been recorded in the vicinity of the project or that are highly associated with habitat that occurs on the project site. Special-status plants were evaluated for their potential to occur within the project site (project footprint) where impacts could potentially occur. Special-status wildlife species were evaluated for their potential to occur within the BSA, a broader area, where direct and indirect impacts could potentially occur. The locations of special-status species observed on the project site are shown in Figure 3.5-10 (Sheet 1 of 9) and Figure 3.5-11 (Sheet 9 of 9). There were no special-status species observed on the east side of the solar facility and the majority of the access road therefore Sheet 2 of 9 through Sheet 8 of 9 of the map set were not included in this EIR. Please see the BRTR for the full map set.

Using information from the literature review and observations in the field, a list of special-status plant and animal species that have potential to occur within the BSA was generated. For the purposes of this assessment, special-status species are defined as plants or animals that:

- have been designated as either rare, threatened, or endangered by CDFW, CNPS, or the USFWS, and/or are protected under either the federal or California ESAs;
- are candidate species being considered or proposed for listing under these same acts;
- are fully protected by the California FGC Sections 3511, 4700, 5050, or 5515; and
- are of expressed concern to resource and regulatory agencies or local jurisdictions.

Biological Reconnaissance Survey

Biological reconnaissance surveys were conducted by ECORP Consulting Inc. on September 28, 2020, April 12, 2022, and 13, 2022, by walking the entire project site to determine the existing vegetation communities and wildlife habitats on the project site. The biologists documented the plant and animal species present and the conditions within the BSA were assessed for their potential to provide habitat for special-status plant and wildlife species, including those identified in the literature review. Plant and wildlife species, including any special-status species that were observed during the survey, were recorded (see Appendix D of this EIR).

Potential for Occurrence Determinations

Special-status species reported for the region in the literature review or for which suitable habitat occurs on the BSA were assessed for their potential to occur based on the following guidelines:

Present: The species was observed onsite during a site visit or focused survey.

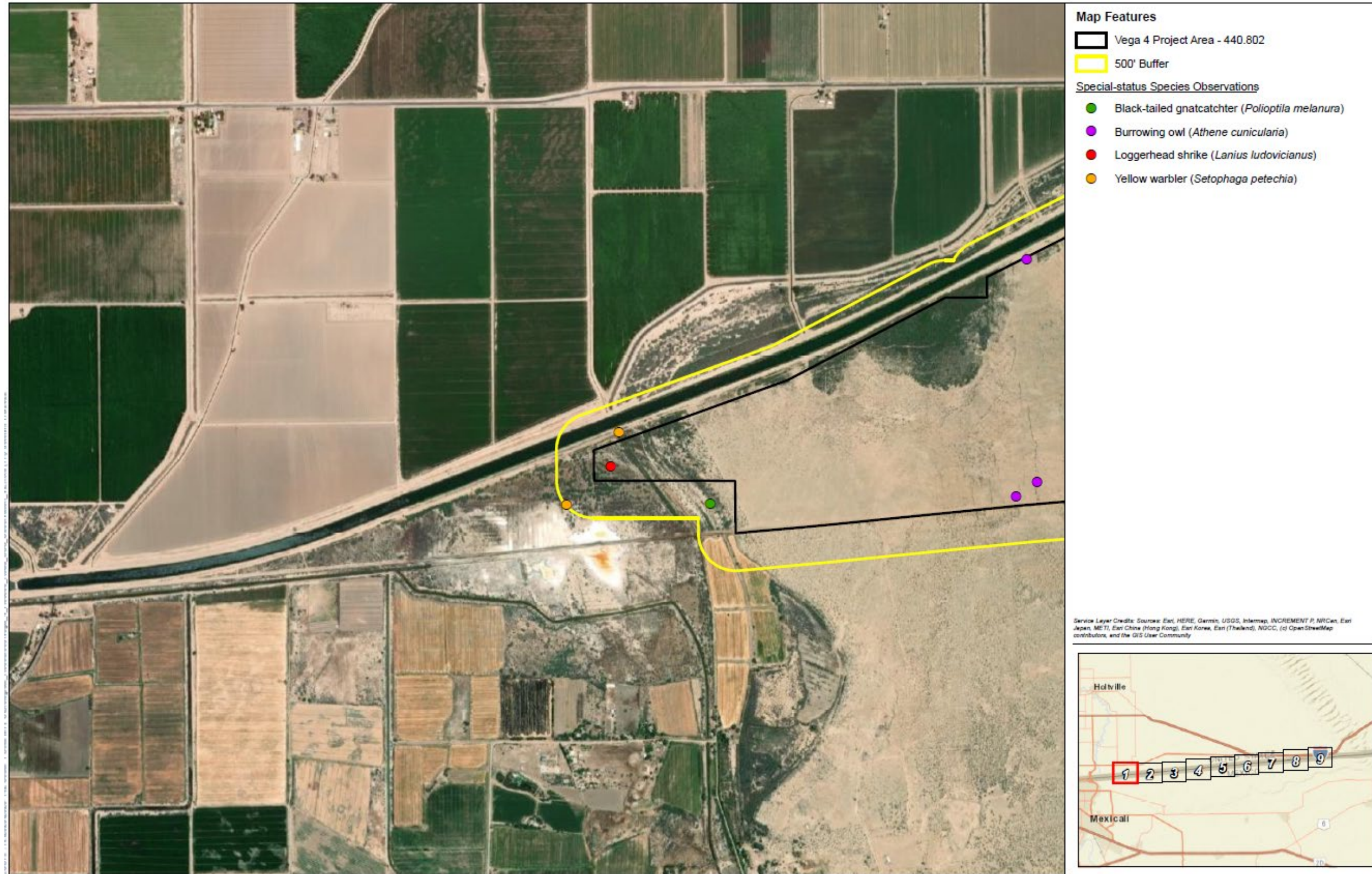
High Potential to Occur: Habitat (including soils and elevation factors) for the species occurs within the BSA and a known occurrence has recently been recorded (within the last 20 years) within five miles of the area.

Moderate Potential to Occur: Habitat (including soils and elevation factors) for the species occurs within the BSA and a documented observation occurs within the database search, but not within five miles of the area; a historic documented observation (more than 20 years old) was recorded within five miles of the BSA; or a recently documented observation occurs within five miles of the area and marginal or limited amounts of habitat occurs in the project site.

Low Potential to Occur: Limited or marginal habitat for the species occurs within the BSA and a recently documented observation occurs within the database search, but not within five miles of the area; a historic documented observation (more than 20 years old) was recorded within five miles of the BSA; or suitable habitat strongly associated with the species occurs on site, but no records or only historic records were found within the database search.

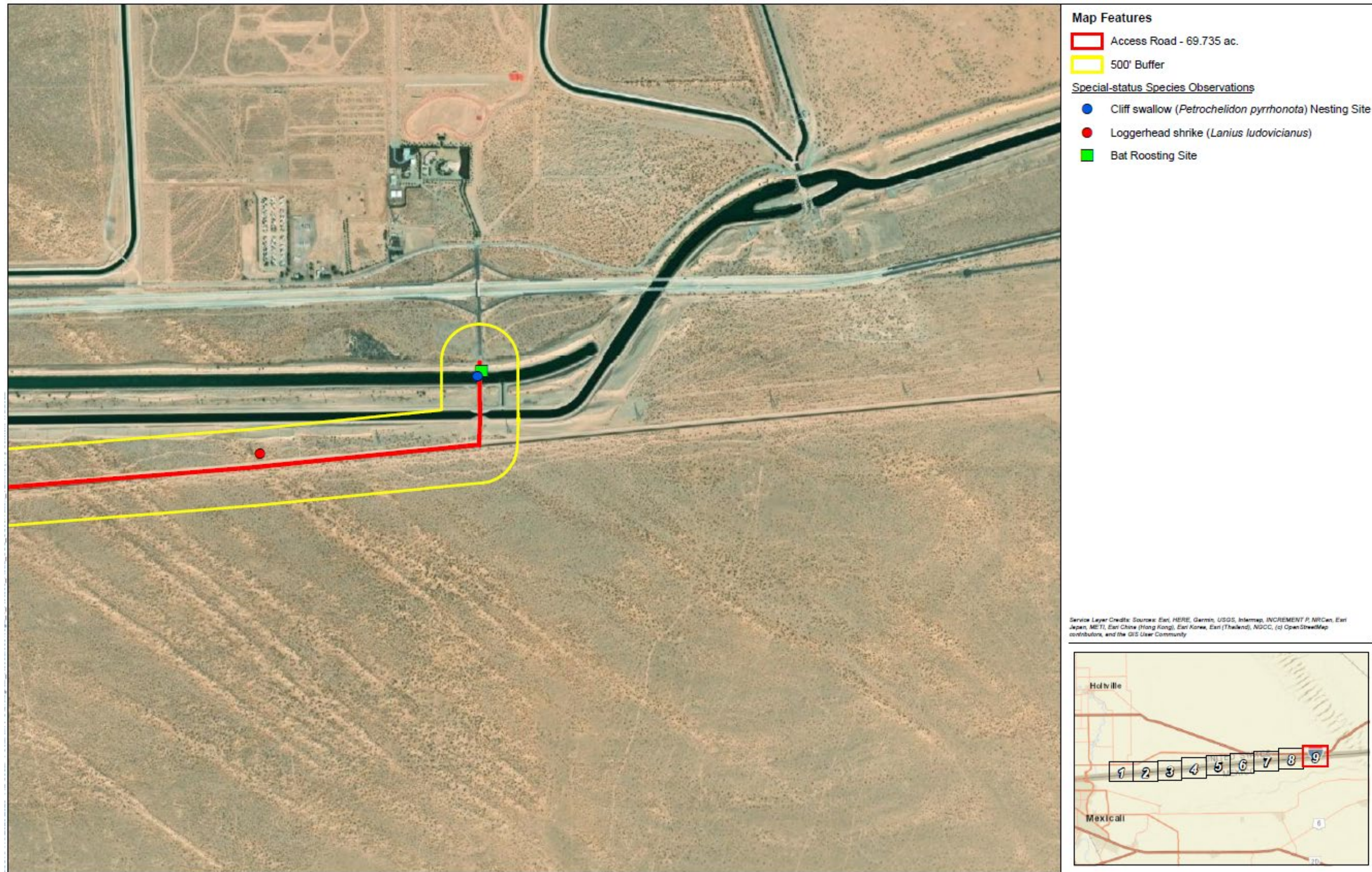
Presumed Absent: Species was not observed during a site visit or focused surveys conducted in accordance with protocol guidelines at an appropriate time for identification; habitat (including soils and elevation factors) does not exist on site; or the known geographic range of the species does not include the BSA.

Figure 3.5-10. Special-Status Species Observed On Site (Sheet 1 of 2)



Source: Appendix D of this EIR

Figure 3.5-11. Special-Status Species Observed On Site (Sheet 2 of 2)



Source: Appendix D of this EIR

Plant Species

PRESENT/OBSERVED

No special-status plant species were observed within the project site during the biological reconnaissance survey.

HIGH POTENTIAL TO OCCUR

No special-status plant species were determined as having a high potential to occur within the project site.

MODERATE POTENTIAL TO OCCUR

Due to the presence of suitable habitat and several known recent occurrences within five miles of the project site, the following species were determined to have moderate potential to occur:

- Abrams' spurge (*Euphorbia abramsiana*) is a CNPS Rare Plant Rank (CRPR) 2B.2¹ plant species. This species is known to occur at elevations between 50 and 100 meters (164 and 328 feet) and blooms between September and November. Abrams' spurge is known to occur in creosote scrub habitat within sandy flats including playas, fields, disturbed areas, and washes. One historic CNDDDB record was located approximately three miles northwest of the site near the Alamo River. Potential habitat occurs on the project site for this species in the disturbed creosote bush scrub habitat and the disturbed creosote bush – white bursage scrub habitat.
- Wiggins' croton (*Croton wigginsii*) is a CRPR 2B.2 plant species. This species is known to occur at elevations between 50 and 100 meters (164 and 328 feet) and blooms between March and May. Wiggins' croton is known to occur in sandy Sonoran desert scrub habitat. Two historic CNDDDB records were recorded with the closest being from 1993 located approximately 0.92 miles east of the Project Area. Potential habitat occurs within Project Area for this species in the sandy, creosote bush scrub and the disturbed creosote bush – white bursage scrub habitats.
- Sand food (*Pholisma sonora*) is a CRPR 1B.2 plant species. Sand food is known to occur at elevations between sea level and 200 meters (sea level and 656 feet) and blooms between April and June. It is known to occur in sandy Sonoran desert scrub habitat. One historic CNDDDB record from 1954 was recorded approximately 0.5 mile north of the Project Area. Potential habitat occurs within the Project Area for this species in the sandy, creosote bush scrub and the disturbed creosote bush – white bursage scrub habitats.

LOW POTENTIAL TO OCCUR

The following species were found to have a low potential to occur on the project site because of limited habitat for the species on the site:

- Watson's amaranth (*Amaranthus watsonii*), CRPR 4.3
- Peirson's milk-vetch (*Astragalus magdalenae* var. *peirsonii*), CRPR 1B.2
- gravel milk-vetch (*Astragalus sabulonum*), CRPR 2B.2

¹ CNPS Rare Plant Rank: 2B = Plants rare, threatened, or endangered in California, but more common elsewhere; .2 Moderately threatened in California (20-80 percent occurrences threatened / moderate degree and immediacy of threat)

- Algodones Dunes sunflower (*Helianthus niveus* ssp. *Tephrodes*), state-listed endangered and CRPR1B.2
- California satintail (*Imperfecta brevifolia*), CRPR 2B.1
- ribbed cryptantha (*Johnstonella costata*), CRPR 4.3
- winged cryptantha (*Johnstonella holoptera*), CRPR 4.3
- hairy stickleaf (*Mentzelia hirsutissima*), CRPR 4.3
- Darlington's blazing star (*Mentzelia puberula*), CRPR 2B.2
- Slender cottonheads (*Nemacaulis denudata* var. *gracilis*), CRPR 2B.2
- Giant Spanish-needle (*Palafoxia arida* var. *gigantea*), CRPR 1B.3

Wildlife Species

The literature search documented 21 special-status wildlife species in the vicinity of the project site, two of which are federally and/or State-listed. Of the 21 special-status wildlife species identified in the literature review, 5 were present within the project site, 2 were found to have a high potential to occur, 7 were found to have a moderate potential to occur and 3 were found to have a low potential to occur. The remaining 3 species are presumed absent from the project site due to lack of suitable habitat on the site: Gila woodpecker (*Melanerpes uropygialis*), western mastiff bat (*Eumops perotis* ssp. *californicus*), and big free-tailed bat (*Nyctinomops macrotis*).

WILDLIFE SPECIES PRESENT/OBSERVED

The following species were observed on the site during the biological reconnaissance survey:

- **Northern harrier, CDFW Species of Special Concern (SSC).** This species typically found in open habitats with dense ground cover including grasslands, agricultural fields, and marshes. Northern harriers nest on the ground, preferring wetland habitat for cover. One adult was observed scanning the landscape during the field surveys.
- **Burrowing owl, USFWS Bird of Conservation Concern (BCC), CDFW SSC, and Imperial County species of conservation focus.** Burrowing owl is typically found in dry open areas with few trees and short grasses; it is also found in vacant lots near human habitation. It uses uninhabited mammal burrows for roosts and nests, often in close proximity to California ground squirrel colonies. It primarily feeds on large insects and small mammals but will also eat birds and amphibians. Three burrowing owls were observed flushing to/from their burrows during field surveys in 2020 (see Figure 3.5-2). One burrowing owl was observed within the southern portion of the project site occupying a burrow along the berm of the access road.
- **Black-tailed gnatcatcher, CDFW watch-list (WL) Species.** This species remains in pairs all year, defending permanent territories. Black-tailed gnatcatchers prefer dry washes or desert brush with varied growth of mesquite, acacias, and paloverdes, but are also known to inhabit tamarisk scrub. A pair of black-tailed gnatcatchers was observed foraging and calling within the tamarisk thicket to the west within the buffer of the project site in 2020. This species was observed again within the same area in 2022 (Figure 3.5-10).
- **Yellow warbler, USFWS BBC and CDFW SCC.** This species prefers scrub and woodlands, particularly along waterways and wetlands. Typically, yellow warblers nest in willows, alders, and cottonwoods, but have been observed nesting in tamarisk scrub. Several adults were

observed foraging in the tamarisk scrub within the buffer to the northwest of the project site during field surveys in 2020 (see Figure 3.5-10).

- **Loggerhead shrike, USFWS BCC and CDFW SSC.** This species prefers open country with scattered shrubs and trees. They frequent agricultural fields, abandoned orchards, desert scrublands, and riparian areas. One individual was observed perching in the tamarisk thickets in the western section of the project site during field surveys in 2020 (see Figure 3.5-10). An individual was also observed perched within the creosote bush scrub habitat to the north of the access road in 2022 (see Figure 3.5-11).

HIGH POTENTIAL TO OCCUR

Although not present during field surveys, two species were found to have high potential to occur on the project site due to the presence of suitable habitat for the species on the site and because a known occurrence has been recorded within five miles of the site:

- **Flat-tailed horned lizard (*Phrynosoma mcallii*), CDFW SSC and Imperial County Species of conservation focus.** This species is most commonly found on sandy flats and valleys within desert scrub habitat with little or no windblown sand. They can also be found on salt flats and gravelly soils. The creosote bush scrub and salt flat habitats provide suitable habitat for the flat-tailed horned lizard.
- **Yuma hispid cotton rat (*Sigmodon hispidus eremicus*), CDFW SSC.** This species is generally associated with mesic habitats near drainage ditches, streams, and sloughs but also occurs in open fields or on the borders of open fields where there is dense grass habitat or agricultural fields. There is potential for this species to occur near the All-American Canal and nearby creosote bush scrub habitat. Two recent CNDDDB records occur less than one mile north of the access road for the site. This species was found in arrow weed scrub and freshwater marsh adjacent to the All-American Canal in 2007.

MODERATE POTENTIAL TO OCCUR

Although not present during field surveys, seven species were found to have moderate potential to occur on the project site because habitat (including soils and elevation factors) for the species occurs on the site:

- **Yuma Ridgway's rail (*Rallus obsoletus yumanensis*), federally listed as endangered and state listed as threatened.** The Yuma Ridgway's rail prefers freshwater marshes composed of cattails and bulrushes. There is suitable habitat for this species within the wetlands nestled within the tamarisk and arrow weed scrub.
- **California horned lark (*Eremophila alpestris ssp. actia*), CDFW WL species.** It occurs in bare, open areas dominated by low vegetation or widely scattered shrubs, including prairies, deserts, and plowed fields. It nests in a hollow on the ground. The disturbed creosote scrub habitat onsite and in the buffer zones provides potential habitat. No CNDDDB records occur within five miles of the project site.
- **Yellow-breasted chat (*Icteria virens*), CDFW SSC.** This species is commonly found in shrublands along rivers. There is potential for the yellow-breasted chat to occur within the arrow weed and tamarisk scrub in the eastern portion of the project site.
- **Pallid bat (*Antrozous pallidus*), CDFW SSC.** This species is commonly found in desert habitat and is known to roost in bridges. Potential roosting habitat for this species is present

within the Gordon Wells Road bridge that crosses over the offline storage canal, north of the All-American Canal.

- **Townsend's big-eared bat (*Corynorhinus townsendii*), CDFW SCC.** The project site is within the known range of this species and this species is known to roost in bridges. Potential roosting habitat for this species is present within the Gordon Road Wells bridge that crosses over the offline storage canal, north of the All-American Canal.
- **Western yellow bat (*Lasiurus xanthinus*), CDFW SSC.** This species is commonly found in desert habitat and is known to roost in the skirts of untrimmed palm trees. Potential roosting habitat for this species is present within the palm trees of the northeastern portion of the project site.
- **Arizona myotis (*Myotis occultus*) is a CDFW SSC.** The project site is within the known range of this species and this species is known to roost in bridges. Potential roosting habitat for this species is present within the Gordon Wells Road bridge that crosses over the offline storage canal, north of the All-American Canal.

LOW POTENTIAL TO OCCUR

Three species were found to have a low potential to occur on the project site because limited habitat for the species occurs on the site and a known occurrence has been reported in the database, but not within five miles of the site, or suitable habitat strongly associated with the species occurs on the site, but no records were found in the database search:

- southwestern willow flycatcher (*Empidonax traillii ssp. extimus*), federally listed endangered and state-listed endangered;
- Sonoran desert toad (*Incilius alvarius*), CDFW SSC; and,
- red-diamond rattlesnake (*Crotalus ruber*), CDFW SSC.

WILDLIFE SPECIES PRESUMED ABSENT

The following three species are presumed absent from the Project Area due to the lack of suitable habitat on the site:

- Gila woodpecker (*Melanerpes uropygialis*), USFWS BCC and CDFW END;
- western mastiff bat (*Eumops perotis ssp. californicus*), CDFW SSC; and
- big free-tailed bat (*Nyctinomops macrotis*), CDFW SSC.

Aquatic Resources

The *Aquatic Resources Delineation Report* identifies the aquatic resources occurring within the project site that may be regulated by the Porter-Cologne Water Quality Act, California Fish and Game Code Sections 1600 and 1602, and USACE pursuant to Sections 401 and 404 of the federal Clean Water Act (CWA).

The boundaries of aquatic resources were delineated through standard field methods (e.g., paired sample set analyses) and aerial photograph interpretation. Field data was recorded on Wetland Determination Data Forms - Arid West Region and Arid West Ordinary High Water Mark (OHWM) Datasheets (see Appendix E of this EIR). ESRI© and SUAS aerial imagery were used to assist with mapping and ground-truthing.



Where jurisdictional features were present, the extent of potential Waters of the State and CDFW-regulated streambed and top-of-bank limits were determined using the OHWM in accordance with USACE requirements and guidelines, as well as SWRCB and CDFW delineation guidance (see Appendix E for details). Streambed widths were based on evidence of OHWM as observed during the field survey. In addition, each of the drainages were evaluated for the presence or absence of sediment deposits, litter/debris, water stains, soil shelving, and/or exposed roots indicating active hydrology within the channel. Streambed widths and other lateral limits of jurisdiction were calculated and recorded. The extent of associated riparian habitat was based on the extent of the canopy of the riparian community within or directly adjacent to the feature. Bank-to-bank width measures were also recorded and used as a measure of CDFW jurisdictional boundary where features lacked riparian vegetation.

A total of 11 resources summing to 2,940.82 acres of aquatic resources have been mapped within the project site. These results are subject to agency verification. Aquatic resources are summarized in Table 3.5-2 and depicted on Figure 3.5-12 through Figure 3.5-17. There were no aquatic resources mapped on the majority of the access road therefore those map sheets were not included in this EIR. Please see the *Aquatic Resources Delineation Report* for the full map set.

Features identified as an aquatic resource had wetland indicators present and/or physical evidence of flow including OHWM, defined bed and bank, presence of a clear and natural line impressed on the bank, the presence or absence of sediment deposits, litter/debris, and/or exposed roots indicating active hydrology within the channel. Associated riparian habitat identified within the project site consisted of hydrophytic vegetation and hydrological indicators but lacked hydric soil indicators.

Table 3.5-2. Aquatic Resources and Associated Vegetation on the Project Site

Resource Name ^a	Aquatic Resources Classification		OHWM/Wetland Presence Summary	Dominant Vegetation	Resource Size (acre)
	Cowardin ^b	Location (latitude/longitude)			
ED-1	R6	32.67954541/ -115.31681051	Runoff and precipitation; OHWM indicators: defined bed and bank and vegetation matted down, bent, or absent.	Tamarisk Thickets	701.55
ED-2	R6	32.67977819/ -115.31686094	Runoff and precipitation; OHWM indicators: defined bed and bank and vegetation matted down, bent, or absent.	Tamarisk Thickets	717.55
ED-3	R6	32.67983223/ -115.31627266	Runoff and precipitation; OHWM indicators: defined bed and bank.	Tamarisk Thickets	806.88
FSW-1	PSS1C	32.67960789/ -115.31829880	Wetland criteria met: hydrophytic vegetation present, hydric soils present,	Arrow Weed Thickets	N/A

Table 3.5-2. Aquatic Resources and Associated Vegetation on the Project Site

Resource Name ^a	Aquatic Resources Classification		OHWM/Wetland Presence Summary	Dominant Vegetation	Resource Size (acre)
	Cowardin ^b	Location (latitude/longitude)			
			and hydrological indicators present.		
FSW-2	PSS1C	32.68345488/ -115.31168036	Wetland criteria met: hydrophytic vegetation present, hydric soils present, and hydrological indicators present.	Tamarisk Thickets	N/A
FSW-3	PSS1C	32.68496608/ -115.30521625	Wetland criteria met: hydrophytic vegetation present, hydric soils present, and hydrological indicators present.	Tamarisk Thickets	N/A
PD-1	R2AB3H	32.67989722/ -115.31746236	Wetland criteria met within the channel with OHWM indicators; bisects wetland riparian habitat.	Tamarisk Thickets	664.88
Unassociated Riparian Habitat	N/A	32.68384969, -115.30666666	N/A	Arrow Weed and Tamarisk Thickets	N/A
Unassociated Disturbed Riparian Habitat	N/A	32.69004265 -115.29438590	N/A	Disturbed Arrow Weed Thickets	N/A
All American Canal ^c	R2UBHx	32.70397136 -114.95717380	N/A	Unvegetated	24.99
Off Line Storage ^c	R2UBHx	32.70532216 -114.95718630	N/A	Unvegetated	24.97
Total					2940.82

Source: Appendix E of this EIR

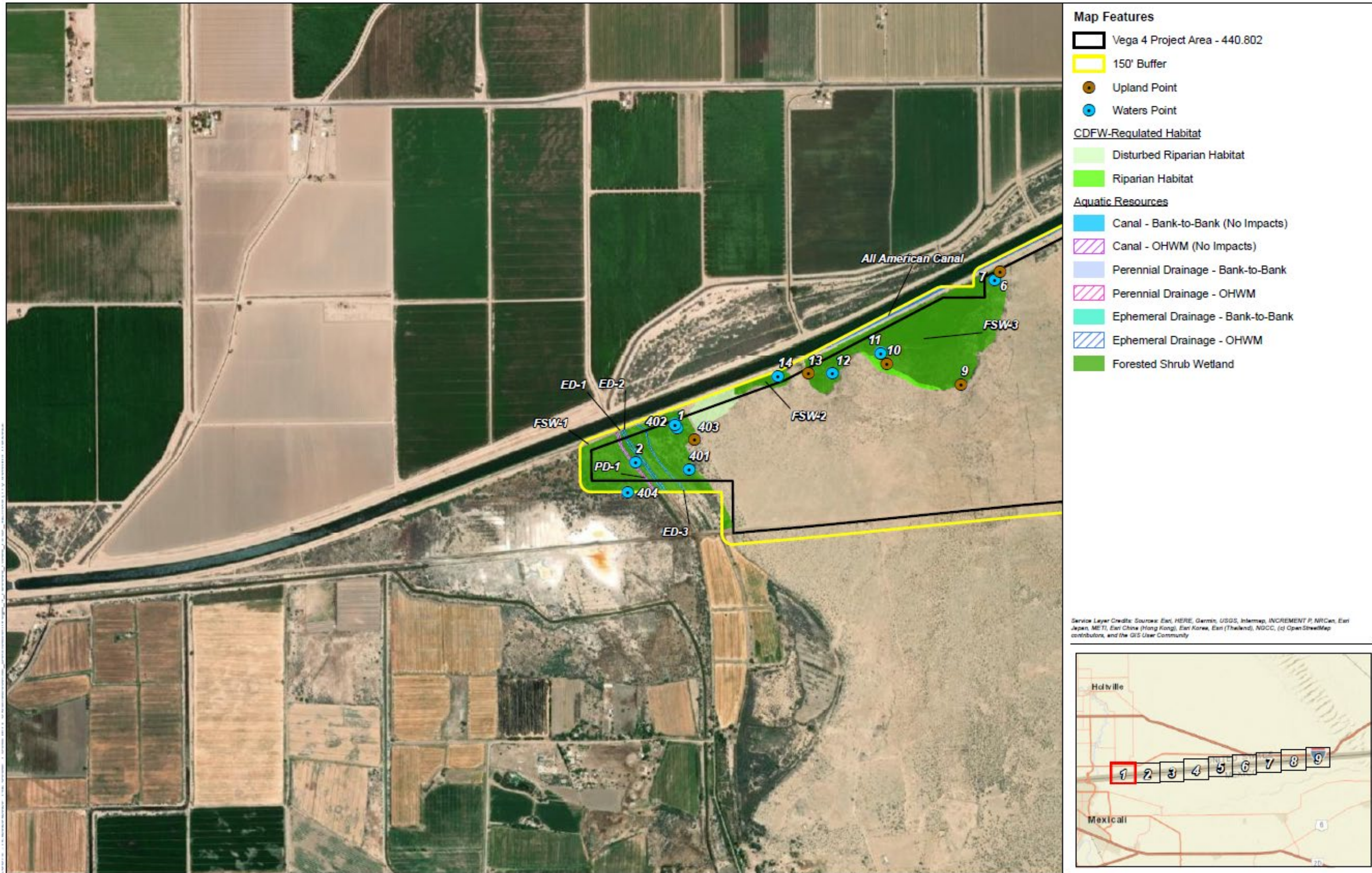
Notes:

a ED= Ephemeral Drainage, FEW= Freshwater Emergent Wetland, FSW= Freshwater Forested/Shrub Wetland, PD= Perennial Drainage.

b Cowardin Codes: (R6) Riverine, ephemeral; (PEM1C) Freshwater Emergent Wetland; (PSS1C) Freshwater Forested/Shrub Wetland; (R2AB3H) Riverine, lower perennial, aquatic bed, rooted vascular.

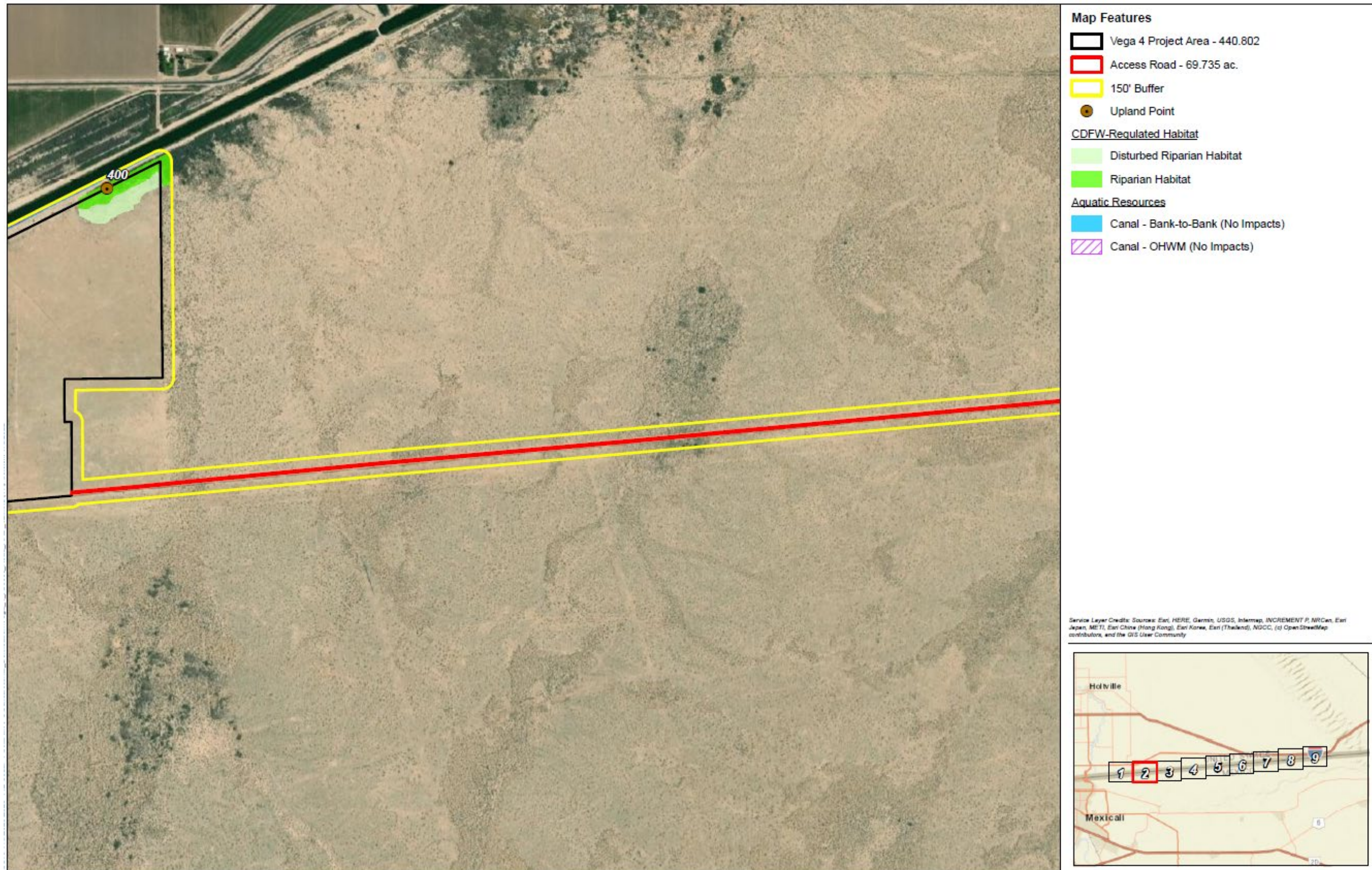
c Impacts to these features are not expected to occur, as features flow beneath access road entry bridge.

Figure 3.5-12. Potential Jurisdictional Waters (Sheet 1 of 6)



Source: Appendix E of this EIR

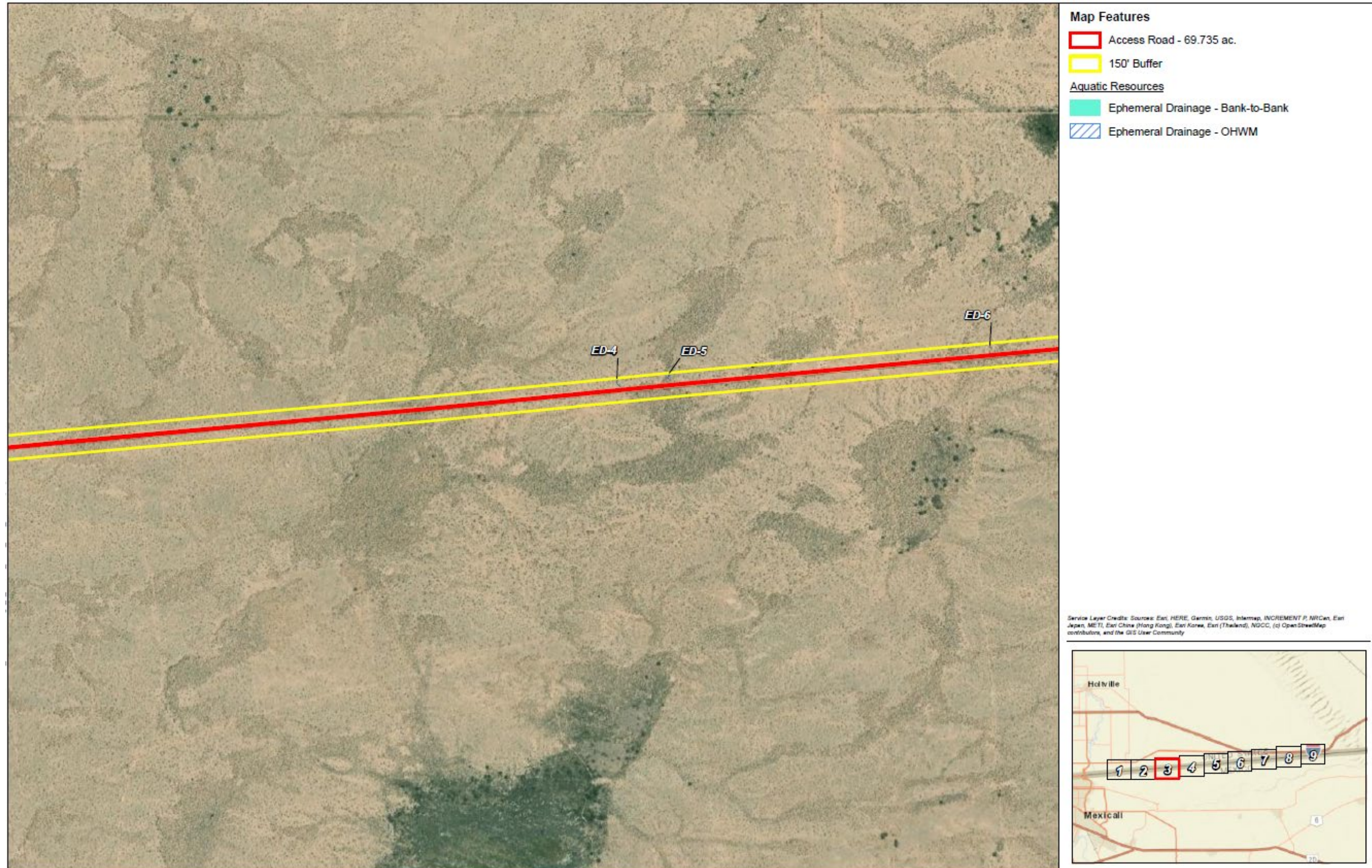
Figure 3.5-13. Potential Jurisdictional Waters (Sheet 2 of 6)



Source: Appendix E of this EIR

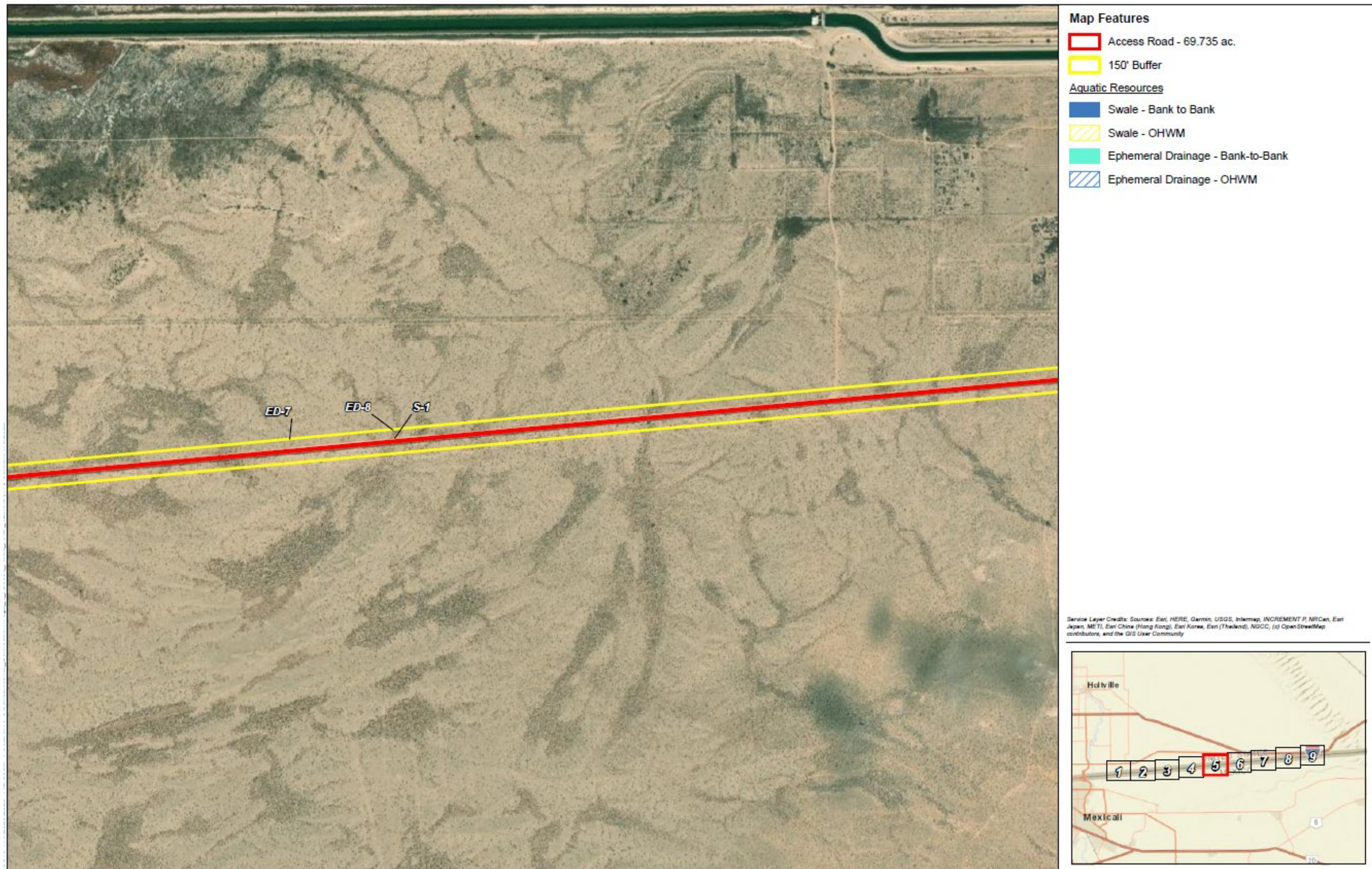


Figure 3.5-14. Potential Jurisdictional Waters (Sheet 3 of 6)



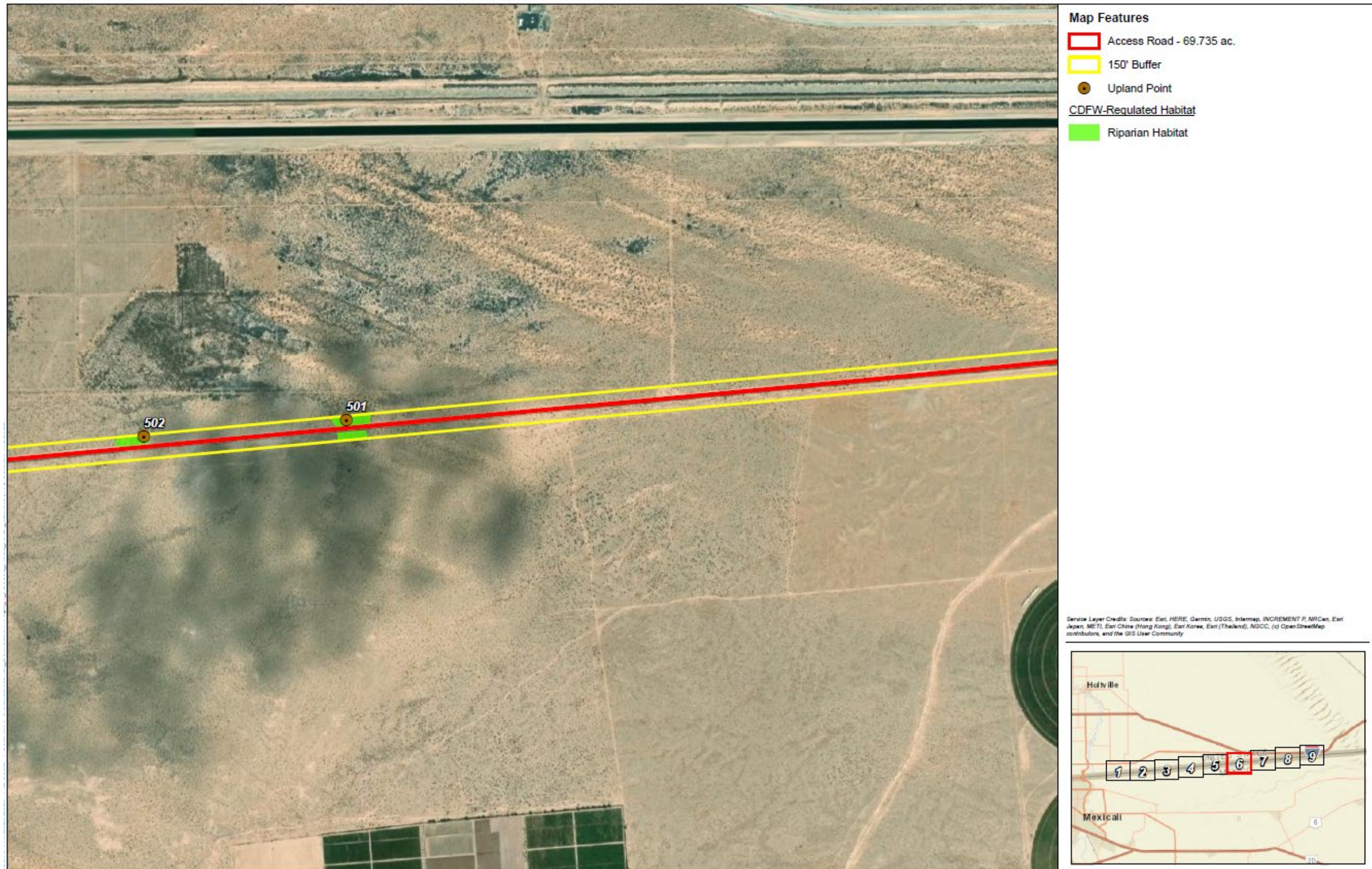
Source: Appendix E of this EIR

Figure 3.5-15. Potential Jurisdictional Waters (Sheet 4 of 6)



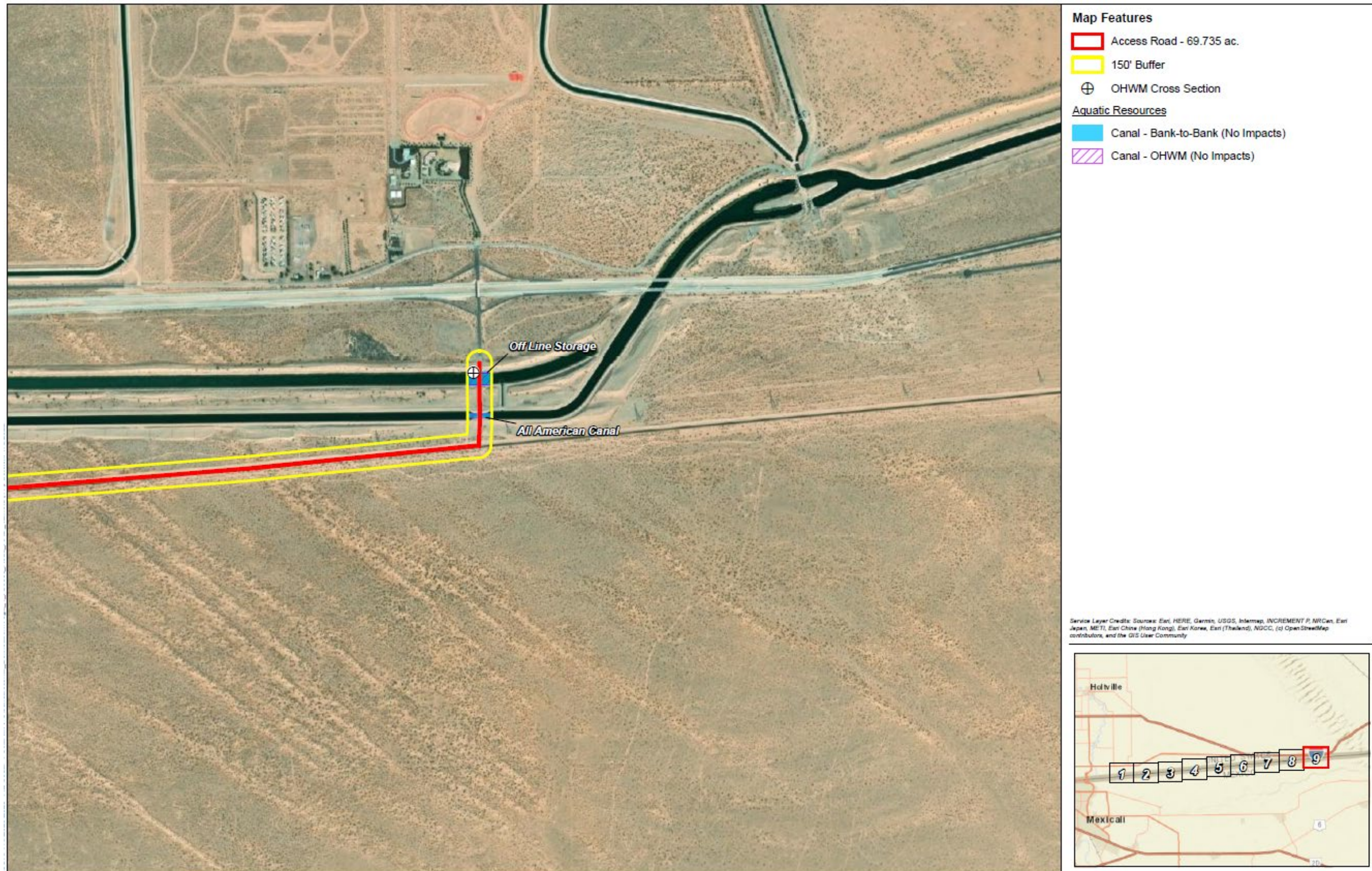
Source: Appendix E of this EIR

Figure 3.5-16. Potential Jurisdictional Waters (Sheet 5 of 6)



Source: Appendix E of this EIR

Figure 3.5-17. Potential Jurisdictional Waters (Sheet 6 of 6)



Source: Appendix E of this EIR

Wetlands

FRESHWATER FORESTED/SHRUB WETLAND

Freshwater forested/shrub wetlands (FSW) are dominated by woody vegetation such as true shrubs, young trees (saplings), and trees or shrubs that are stunted due to environmental conditions. They are seasonally flooded: therefore, surface water is present for extended periods, particularly in the early growing season, but is absent by the end of the growing season in most years. The water table can be variable after a flooding event, and ranges from saturation at the ground surface to a water table well below the ground surface. As shown in Table 3.5-2 and Figure 3.5-12, there are three FSW within the project site (FSW-1, FSW-2, and FSW-3).

Other Aquatic Resources

PERENNIAL DRAINAGE

Perennial drainages (PD) are linear features that exhibit a bed and bank and an OHWM. These features typically contain surface water flowing continuously year-round. As shown in Table 3.5-2 and Figure 3.5-12, there is one PD within the project site. OHWM indicators observed for the perennial drainage (PD-1) that occurs within the western portion of the project site included defined bed and bank, change in vegetation species, change in vegetation cover, and natural line impressed in bank. The existing hydrology of PD-1 supports emergent wetland habitat within the channel.

EPHEMERAL DRAINAGE

Ephemeral drainages (ED) are linear features that exhibit a bed and bank and an OHWM. These features typically convey runoff for short periods of time, during and immediately following rain events, and are not influenced by groundwater sources at any time during the year. As shown in Table 3.5-2 and Figure 3.5-12, the project site contains three ephemeral drainages within the western portion of the site (ED-1, ED-2, and ED-3). These manmade drainages convey flow through the project site and into a freshwater emergent wetland located off-site to the west.

MANMADE FEATURES

A total of two main canals managed by IID, the All-American Canal and the associated Off-line Storage Canal, were identified within the access road portion of the Study Area and are assumed to flow perennially. Both canals bisect the easternmost portion of the Study Area (Figure 3.5-17). The concrete-lined All-American Canal is maintained by IID in order to be free of vegetation for water conveyance efficiency. The Off-line Storage Canal is natural-bottomed, and flow and water levels are maintained by IID. The All-American Canal brings water from the Colorado River at the Imperial Dam and supplies it to the Imperial Valley through smaller lateral canals, all of which ultimately drain to the Salton Sea (Appendix E). Because these canals flow underneath the access road entry bridge, no impacts are expected to occur to either canal.

Wildlife Movement Corridors, Linkages, and Significant Ecological Areas

The concept of habitat corridors addresses the linkage between large blocks of habitat that allow the safe movement of mammals and other wildlife species from one habitat area to another. The definition of a corridor is varied, but corridors may include such areas as greenbelts, refuge systems, underpasses, and biogeographic land bridges, for example. In general, a corridor is described as a linear habitat, embedded in a dissimilar matrix, which connects two or more large blocks of habitat. Wildlife movement corridors are critical for the survivorship of ecological systems for several reasons.

Corridors can connect water, food, and cover sources, spatially linking these three resources with wildlife in different areas. In addition, wildlife movement between habitat areas provides for the potential of genetic exchange between wildlife species populations, thereby maintaining genetic variability and adaptability to maximize the success of wildlife responses to changing environmental conditions. This is especially critical for small populations subject to loss of variability from genetic drift and effects of inbreeding. Naturally, the nature of corridor use and wildlife movement patterns varies greatly among species.

The project site was assessed for its ability to function as a wildlife corridor. The project site has an extensive riparian corridor in the western corner of the site that provides cover for migrating and nesting birds. It also provides foraging habitat for raptors and small and large mammals, including rodents and canids. The desert washes located within the western corner of the project boundaries are likely utilized by wildlife moving through the area; therefore, these features and associated riparian habitat would be considered necessary linkages between conserved natural habitat areas or critical for wildlife movement because of the nearby direct connectivity to wetlands to the south of the project site. The northern and southern boundaries are restricted by the All-American Canal to the north and the U.S./Mexico border wall borders the southern buffer of the BSA. Although the border wall inhibits large mammal movement, avian species and small mammals may fly over or cross through the wall.

The disturbed creosote bush scrub portion of the project site is sparse with low plant diversity, and therefore offers little shelter and foraging habitat. The project site is open with barriers to the north and south, leaving the terrain accessibility constrained for ground-truthing wildlife. The project borders the western edge of expansive agricultural fields and is surrounded to the north, west, and south by agriculture. Thus, the creosote scrub habitat only currently provides wildlife movement opportunities to the east because it consists of open and relatively unimpeded land. In conclusion, the creosote bush scrub habitat portion of the project site would not be considered a wildlife movement corridor that would need to be preserved to allow wildlife to move between important natural habitat areas due to the lack of conserved natural lands in the vicinity and the project's proximity to farming lands. The creosote bush scrub habitat within the project boundaries is exposed and does not contain any major features that would be considered critical movement corridors for wildlife. Therefore, the creosote bush habitat acts as more of a buffer between agricultural lands and wildlands to the east, but not as a corridor for wildlife.

Habitat Conservation Plans

The project site is not located in a Habitat Conservation Plan, Natural Community Conservation Plan, or other approved local, regional, or state habitat conservation plan.

3.5.2 Regulatory Setting

This section identifies and summarizes federal, state, and local laws, policies, and regulations that are applicable to the project.

Federal

Federal Endangered Species Act

The Federal Endangered Species Act (ESA) protects federally listed threatened and endangered species and their habitats from unlawful take and ensures that federal actions do not jeopardize the continued existence of a listed species or result in the destruction or adverse modification of

designated critical habitat. Under the ESA, “take” is defined as to harass, harm, pursue, hunt, shoot, wound, kill, trap, capture, or collect, or to attempt to engage in any such conduct. The U.S. Fish and Wildlife Service (USFWS) regulations define harm to mean “an act which actually kills or injures wildlife” (50 CFR 17.3).

Bald and Golden Eagle Protection Act of 1940

The Bald Eagle Protection Act of 1940 protects bald eagle (*Haliaeetus leucocephalus*) and golden eagle (*Aquila chrysaetos*) by prohibiting the taking, possession, and commerce of such birds and establishes civil penalties for violation of this Act. ‘Take’ is defined as “pursue, shoot, shoot at, poison, wound, kill, capture, trap, collect, molest or disturb.” ‘Disturb’ is defined as “to agitate or bother a bald or golden eagle to a degree that causes, or is likely to cause, based on the best scientific information available: (1) injury to an eagle, (2) a decrease in its productivity, by substantially interfering with normal breeding, feeding, or sheltering behavior, or (3) nest abandonment, by substantially interfering with normal breeding, feeding, or sheltering behavior” (72 *Federal Register* [FR] 31132; 50 CFR 22.3). All activities that may disturb or incidentally take an eagle or its nest as a result of an otherwise legal activity must be permitted by the USFWS under this Act.

Migratory Bird Treaty Act

The Migratory Bird Treaty Act (MBTA) prohibits the kill or transport of native migratory birds, or any part, nest, or egg of any such bird unless allowed by another regulation adopted in accordance with the MBTA. The prohibition applies to birds included in the respective international conventions between the U.S. and Great Britain, the U.S. and Mexico, the U.S. and Japan, and the U.S. and Russia. Disturbances that cause nest abandonment and/or loss of reproductive effort or the loss of habitats upon which these birds depend may be a violation of the MBTA. As authorized by the MBTA, the USFWS issues permits to qualified applicants for the following types of activities: falconry, raptor propagation, scientific collecting, special purposes (rehabilitation, education, migratory game bird propagation, and salvage), take of depredating birds, taxidermy, and waterfowl sale and disposal. The regulations governing migratory bird permits can be found in 50 CFR Part 13 General Permit Procedures and 50 CFR Part 21 Migratory Bird Permits. The State of California has incorporated the protection of birds of prey in Sections 3800, 3513, and 3503.5 of the California Fish and Game Code.

Section 404 Permit (Clean Water Act)

The purpose of the Clean Water Act (CWA) is to “restore and maintain the chemical, physical, and biological integrity of the nation’s waters.” Section 404 of the CWA prohibits the discharge of dredge and fill material into waters of the U.S., including wetlands, without a permit from the U.S. Army Corps of Engineers (USACE). Activities regulated under this program include fills for development, water resource projects (e.g., dams and levees), infrastructure development (e.g., highways and airports), and conversion of wetlands to uplands for farming and forestry. Either an individual 404b permit or authorization to use an existing USACE Nationwide Permit will need to be obtained if any portion of the construction requires fill into a river, stream, or stream bed that has been determined to be a jurisdictional waterway.

State

California Endangered Species Act

Provisions of CESA protect state-listed threatened and endangered species. The California Department of Fish and Wildlife (CDFW) regulates activities that may result in “take” of individuals (“take” means “hunt, pursue, catch, capture, or kill, or attempt to hunt, pursue, catch, capture, or kill”). Habitat degradation or modification is not expressly included in the definition of “take” under the California Fish and Game Code (FGC). Additionally, California FGC contains lists of vertebrate species designated as “fully protected” (California FGC Sections 3511 [birds], 4700 [mammals], 5050 [reptiles and amphibians], 5515 [fish]). Such species may not be taken or possessed.

In addition to state-listed species, CDFW has also produced a list of Species of Special Concern to serve as a “watch list.” Species on this list are of limited distribution or the extent of their habitats has been reduced substantially such that threats to their populations may be imminent. Species of Special Concern may receive special attention during environmental review, but they do not have statutory protection.

Birds of prey are protected in California under California FGC. Section 3503.5 states it is “unlawful to take, possess, or destroy any birds of prey (in the order Falconiformes or Strigiformes) or to take, possess, or destroy the nest or eggs of any such bird except as otherwise provided by this Code or any regulation adopted pursuant thereto.” Construction disturbance during the breeding season could result in the incidental loss of fertile eggs or nestlings or otherwise lead to nest abandonment.

California Fish and Game Code Section 1600 et. seq (as amended)

The California FGC Section 1600 et. seq. requires that a Notification of Lake or Streambed Alteration be submitted to CDFW for “any activity that may substantially divert or obstruct the natural flow or substantially change the bed, channel, or bank of any river, stream, or lake.” The CDFW reviews the proposed actions and, if necessary, submits to the Applicant a proposal for measures to protect affected fish and wildlife resources. The final proposal that is mutually agreed upon by CDFW and the Applicant is the Streambed Alteration Agreement (SAA). Often, projects that require an SAA also require a permit from the USACE under Section 404 of the CWA. In these instances, the conditions of the Section 404 permit and the SAA may overlap.

California Fish and Game Code Sections 3503, 3503.5, and 3513

Under Sections 3503, 3503.5, and 3513 of the California FGC, activities that would result in the taking, possessing, or destroying of any birds-of-prey, taking or possessing of any migratory nongame bird as designated by the MBTA, or the taking, possessing, or needlessly destroying of the nest or eggs of any raptors or non-game birds protected by the MBTA, or the taking of any non-game bird pursuant to FGC Section 3800 are prohibited. Additionally, the state further protects certain species of fish, mammals, amphibians and reptiles, birds, and mammals through CDFW’s Fully Protected Animals which prohibits any take or possession of classified species.

California Fish and Game Code Sections 1900-1913 (Native Plant Protection Act)

California’s Native Plant Protection Act prohibits the taking, possessing, or sale within the state of any plant listed by CDFW as rare, threatened, or endangered. This allows CDFW to salvage listed plant species that would otherwise be destroyed.

Porter-Cologne Water Quality Control Act

Under the Porter-Cologne Water Quality Control Act, all projects proposing to discharge waste that could affect waters of the State must file a waste discharge report with the appropriate regional board. The project falls under the jurisdiction of the Colorado River RWQCB.

California Environmental Quality Act

Title 14 CCR, Section 15380 requires the identification of endangered, rare, or threatened species or subspecies of animals or plants that may be impacted by a project. If any such species are found, appropriate measures should be identified to avoid, minimize, or mitigate the potential effects of projects.

Local

Imperial County General Plan

The Conservation and Open Space Element of the Imperial County General Plan provides detailed plans and measures for the preservation and management of biological and cultural resources, soils, minerals, energy, regional aesthetics, air quality, and open space. The purpose of this element is to recognize that natural resources must be maintained for their ecological value for the direct benefit to the public and to protect open space for the preservation of natural resources, the managed production of resources, outdoor recreation, and for public health and safety. In addition, the purpose of this element is to promote the protection, maintenance, and use of the County’s natural resources with particular emphasis on scarce resources, and to prevent wasteful exploitation, destruction, and neglect of the state’s natural resources. Table 3.5-3 analyzes the consistency of the project with specific policies contained in the Imperial County General Plan associated with biological resources.

Table 3.5-3. Project Consistency with General Plan Goals and Policies

General Plan Policies	Consistency with General Plan	Analysis
<p>Conservation and Open Space Element - <i>Open Space and Recreation Conservation</i></p> <p>Policy No. 2 - The County shall participate in conducting detailed investigations into the significance, location, extent, and condition of natural resources in the County.</p> <p>Program: Notify any agency responsible for protecting plant and wildlife before approving a project which would impact a rare, sensitive, or unique plant or wildlife habitat.</p>	<p>Consistent</p>	<p>A biological assessment has been conducted at the project site to evaluate the proposed project’s potential impacts on biological resources. No special-status plant species were identified within the BSA. Five special-status wildlife species, including burrowing owl, were identified within the project site. However, with implementation of Mitigation Measures BIO-1 through BIO-7, potential impacts to these species would be reduced to a level less than significant.</p> <p>Applicable agencies responsible for protecting plants and wildlife will be notified of the proposed project and provided an opportunity to comment on this EIR prior to the County’s consideration of any approvals for the project.</p>

Table 3.5-3. Project Consistency with General Plan Goals and Policies

General Plan Policies	Consistency with General Plan	Analysis
<p><i>Conservation of Environmental Resources for Future Generations</i></p> <p>Goal 1 - Environmental resources shall be conserved for future generations by minimizing environmental impacts in all land use decisions and educating the public on their value.</p> <p>Objective 1.6 - Promote the conservation of ecological sites and preservation of cultural resource sites through scientific investigation and public education.</p>	<p>Consistent</p>	<p>A biological assessment has been conducted at the project site to evaluate the project’s potential impacts on biological resources. No special-status plant species were identified within the BSA. Five special-status wildlife species, including burrowing owl, were identified within the BSA. However, with implementation of Mitigation Measures BIO-1 through BIO-7, potential impacts to these species would be reduced to a level less than significant.</p> <p>With implementation of Mitigation Measures BIO-1 through BIO-7, the project would not result in residual significant and unmitigable impacts on biological resources.</p>

Source: County of Imperial 1993
 BLM=Bureau of Land Management; CDFW – California Department of Fish and Wildlife; EIR – environmental impact report;
 USFWS – U.S. Fish and Wildlife Service

3.5.3 Impacts and Mitigation Measures

This section presents the significance criteria used for considering project impacts on biological resources, the methodology employed for the evaluation, an impact evaluation, and mitigation requirements, if necessary.

Thresholds of Significance

Based on CEQA Guidelines Appendix G, project impacts related to biological resources are considered significant if any of the following occur:

- Have a substantial adverse effect, either directly or through habitat modifications, on any species identified as a candidate, sensitive, or special status species in local or regional plans, policies, or regulations, or by the CDFW or USFWS
- Have a substantial adverse effect on any riparian habitat or other sensitive natural community identified in local or regional plans, policies, regulations or by the CDFW or USFWS
- Have a substantial adverse effect on state or federally-protected wetlands (including but not limited to, marsh, vernal pool, coastal, etc.) through direct removal, filling, hydrological interruption, or other means
- Interfere substantially with the movement of any native resident or migratory fish and wildlife species or with established native resident or migratory wildlife corridors, or impede the use of native wildlife nursery sites
- Conflict with any local policies or ordinances protecting biological resources, such as a tree preservation policy or ordinance
- Conflict with the provisions of an adopted Habitat Conservation Plan, Natural Community Conservation Plan, or other approved local, regional, or state habitat conservation plan

Methodology

This analysis evaluates the potential for the project, as described in Chapter 2, Project Description, to interact with local biological resources on the project site. Based on the extent of these interactions, this analysis considers whether these conditions would result in an exceedance of one or more of the applied significance criteria as identified above.

A biological resources technical report and aquatic resources delineation report were prepared for the project. The information obtained from the sources was reviewed and summarized to present the existing conditions and to identify potential environmental impacts, based on the significance criteria presented in this section. Impacts associated with biological resources that could result from project construction and operational activities were evaluated qualitatively based on-site conditions; expected construction practices; and materials, locations, and duration of project construction and related activities.

Impact Analysis

Impact 3.5-1 Would the project have a substantial adverse effect, either directly or through habitat modifications, on any species identified as a candidate, sensitive, or special status species in local or regional plans, policies, or regulations, or by the CDFW or USFWS?

SOLAR ENERGY FACILITY, BATTERY STORAGE SYSTEM, AND GEN-TIE LINE

Construction

SPECIAL-STATUS PLANTS

As stated above, the literature review identified 14 special-status plant species that have the potential to occur within the project site. However, 11 of these plant species have a low potential to occur due to limited suitable habitat. There is moderate potential for three rare plant species, Abram's spurge (CRPR 2B.2), Wiggins' croton (CRPR 2B.2), and sand food (CRPR 1B.2), to be present within the project area. Suitable habitat for these species is present within the creosote bush scrub and disturbed creosote bush – white bursage scrub habitats. Impacts that may occur to the species during project construction includes loss of individuals, habitat, and seedbank. Depending on the size of the population, potential impacts be significant. Implementation of Mitigation Measures BIO-1, BIO-2, and BIO-3 would reduce impacts to a level less than significant.

SPECIAL-STATUS WILDLIFE

The literature review identified 21 special-status wildlife species that have the potential to occur within the project site. However, six of these species have a low or no potential to occur due to the lack of suitable and/or limited habitat within the project site. Wildlife species that are presumed absent from the project site include Gila woodpecker, western mastiff bat, and big free-tailed bat. Wildlife species with a low potential to occur include Sonoran Desert toad, red-diamond rattlesnake, and southwestern willow flycatcher.

Five special-status wildlife species were observed on site during the habitat assessment: black-tailed gnatcatcher, northern harrier, burrowing owl, yellow warblers, and loggerhead shrikes were observed in the tamarisk thickets in the western portion of the project site. Burrowing owl and their burrows were observed within the disturbed creosote-white bursage scrub in the western portion of the project site,

within a berm adjacent to the access road, and in a concrete pile in the northeastern corner of the site. The proposed project has been designed to avoid impacts to tamarisk thickets occurring on the project site. As shown on the Site Plan (Figure 2-3), project components would not be sited on the project site where tamarisk thickets are present. This vegetation community would not be removed on the project site thereby avoiding habitat removal. However, there is still potential that construction activities occurring adjacent to this vegetation community could result in direct and indirect impacts on special-status species. Direct construction-related impacts to wildlife species that could occur include injury, mortality, nest failures, and loss of young. Indirect impacts include increase in anthropogenic effects (i.e., noise levels, introduction of invasive/nonnative species, increase in human activity, and increase in dust. However, implementation of Mitigation Measures BIO-2, BIO-3, BIO-4, BIO-5, and BIO-6 would reduce potential impacts to a level less than significant.

Foraging habitat for a number of raptor species and breeding habitat for numerous passerine species that are protected by the MBTA occurs throughout the project site. The project site provides nesting habitat for ground-nesting species as well as species that nest in riparian scrub habitat. Due to the lack of large trees within the survey area, there is no suitable nesting habitat for raptor species. However, northern harriers are ground nesters; therefore, the tamarisk thicket and disturbed arrow weed thicket habitats provide potential nesting habitat for this species. Direct impacts to nesting avian species include injury, mortality, loss of young, and nest failure. Indirect impacts include loss of foraging and nesting habitat for passerine and raptors species, increase in noise and human activities, and potential introduction of invasive/nonnative species. Potential impacts would be considered significant. Implementation of Mitigation Measures BIO-2, BIO-5, and BIO-6 would reduce potential impacts to a level less than significant.

The palm trees located within the project site may provide roosting habitats for bat species, particularly western yellow bat, a SSC species. These trees could function as maternity roost sites for this species. During the 2022 assessment of the access road, a bat roost was observed within the bridge at Gordon Wells Road that crosses the offline storage canal, north of the All-American Canal. Bat species in California are protected by Section 4150 (protection of non-game mammals from take) of the California Fish and Game Code. Section 4150 of the California Fish and Game Code prohibits the take of any naturally occurring mammals in California that are nongame mammals, which includes all species of the Order Chiroptera (bats). Based on the quantity of bats within the bridge and the timing of the observation of the colony, there is high likelihood that this is a maternity roost. The Gordon Wells Road bridge will be used for access to the solar field portion of the project site and no direct impacts are expected to occur to the bridge. However, there may be indirect impacts to the roost through noise and vibration, due to a temporary increase in traffic above the bridge during construction. However, because the bridge currently functions as an active roadway, the colony would be expected to be accustomed to noise and vibrations associated with traffic and indirect impacts would not be expected to be significant. The solar facility site is located approximately 22 miles west of the bridge and work is expected to occur within a 12-month period. An increase in truck traffic over the bridge to facilitate construction of the project is not expected to have a significant impact on the bat colony and will be temporary in nature.

Operation

All electrical components on the project site shall be either undergrounded or protected so that there will be no exposure to wildlife and therefore no potential for electrocution. Additionally, based on the Avian Powerline Interaction Committee's (APLIC) 1996 report on power line electrocution in the U.S., avian electrocution risk is highest along distribution lines (generally less than 69 kV) where the

distance between energized phases, ground wires, transformers, and other components of an electrical distribution system are less than the length or skin-to-skin contact distance of birds. The distance between energized components along transmission lines (>69 kV) is generally insufficient to present avian electrocution risk. Therefore, no impact to avian is anticipated to occur due to electrocution along the proposed gen-tie line.

CONSTRUCTION ACCESS ROAD

During construction, vendors and heavy construction equipment would access the project site via Gordon Wells Road approximately 20 miles east of the project site, then travel west along an existing dirt road paralleling the U.S./Mexico Border. This existing dirt road is actively used by the U.S. Border Patrol during patrol operations. The dirt road is on urban/developed land. The use of this access road during construction is not anticipated to result in potential impacts on biological resources, with the exception of roosting bats, if present. Bat acoustic surveys and monitoring should be implemented to determine if sensitive bat species occur within the Gordon Road Wells bridge or palm trees (if planned for removal). All bat species with potential for occurrence for the project are SSC species and potential project-related impacts to bat species and bat maternity roosts are considered significant. Implementation of BIO-7 would reduce impacts to bat species and maternity roosts to a level less than significant.

Because vehicles and construction equipment would be required to stay within the existing boundaries of the dirt road to avoid and/or minimize ground disturbance to undisturbed and vegetated areas, other impacts to biological resources are not anticipated. Furthermore, the project applicant would not make improvements to the existing dirt road except for the application of water for dust suppression.

Mitigation Measure(s)

BIO-1 Rare Plant Surveys. Prior to initiating ground disturbance, rare plant surveys shall be conducted within suitable habitat on the project site during the appropriate blooming period for the Abrams' spurge (approximately September through November), Wiggins' croton (approximately March through May), and sand food (approximately April through June). The surveys shall be conducted by a botanist or qualified biologist in accordance with the USFWS Guidelines for Conducting and Reporting Botanical Inventories for Federally Listed, Proposed, and Candidate Plants (USFWS 1996); the CDFW Protocols for Surveying and Evaluating Impacts to Special Status Native Plant Populations and Sensitive Natural Communities (CDFW 2018); and the CNPS Botanical Survey Guidelines (CNPS 2001). If any special-status species are observed during the rare plant surveys, the location of the individual plant or population will be recorded with a submeter GPS device for mapping purposes. If project-related impacts to rare plants on the project site are unavoidable, then consultation with CDFW may be required to develop a mitigation plan or additional avoidance and minimization measures. Mitigation measures that may be implemented if the species is observed include establishing a no-disturbance buffer around locations of individuals or a population, salvage or seed collection, and additional monitoring requirements.

BIO-2 General Impact Avoidance and Minimization Measures. The following measures will be applicable throughout the life of the project:

- To reduce the potential indirect impact on migratory birds, bats and raptors, the project will comply with the APLIC 2012 Guidelines for overhead utilities, as appropriate, to minimize avian collisions with transmission facilities (APLIC 2012)

- All electrical components on the project site shall be either undergrounded or protected so that there will be no exposure to wildlife and therefore no potential for electrocution.
- The project proponent shall designate a Project Biologist who shall be responsible for overseeing compliance with protective measures for the biological resources during vegetation clearing and work activities within and adjacent to areas of native habitat. The Project Biologist will be familiar with the local habitats, plants, and wildlife. The Project Biologist will also maintain communications with the Contractor to ensure that issues relating to biological resources are appropriately and lawfully managed and monitor construction. The Project Biologist will monitor activities within construction areas during critical times, such as vegetation removal, the implementation of Best Management Practices (BMP), and installation of security fencing to protect native species. The Project Biologist will ensure that all wildlife and regulatory agency permit requirements, conservation measures, and general avoidance and minimization measures are properly implemented and followed.
- The boundaries of all areas to be newly disturbed (including solar facility areas, staging areas, access roads, and sites for temporary placement of construction materials and spoils) will be delineated with stakes and flagging prior to disturbance. All disturbances, vehicles, and equipment will be confined to the flagged areas.
- No potential wildlife entrapments (e.g., trenches, bores) will be left uncovered overnight. Any uncovered pitfalls will be excavated to 3:1 slopes at the ends to provide wildlife escape ramps. Alternatively, man-made ramps may be installed. Covered pitfalls will be covered completely to prevent access by small mammals or reptiles.
- To avoid wildlife entrapment (including birds), all pipes or other construction materials or supplies will be covered or capped in storage or laydown area, and at the end of each workday in construction, quarrying and processing/handling areas. No pipes or tubing of sizes or inside diameters ranging from 1 to 10 inches will be left open either temporarily or permanently.
- No anticoagulant rodenticides, such as Warfarin and related compounds (indandiones and hydroxycoumarins), may be used within the project site, on off-site project facilities and activities, or in support of any other project activities.
- Avoid wildlife attractants. All trash and food-related waste shall be placed in self-closing containers and removed regularly from the site to prevent overflow. Workers shall not feed wildlife. Water applied to dirt roads and construction areas for dust abatement shall use the minimal amount needed to meet safety and air quality standards to prevent the formation of puddles, which could attract wildlife. Pooled rainwater or floodwater within retention basins will be removed to avoid attracting wildlife to the active work areas.
- To minimize the likelihood for vehicle strikes on wildlife, speed limits will not exceed 15 miles per hour when driving on access roads. All vehicles required for O&M must remain on designated access/maintenance roads.

- Avoid night-time construction lighting or if nighttime construction cannot be avoided use shielded directional lighting pointed downward and towards the interior of the project site, thereby avoiding illumination of adjacent natural areas and the night sky.
- All construction equipment used for the Project will be equipped with properly operating and maintained mufflers.
- Hazardous materials and equipment stored overnight, including small amounts of fuel to refuel hand-held equipment, will be stored within secondary containment when within 50 feet of open water to the fullest extent practicable. Secondary containment will consist of a ring of sandbags around each piece of stored equipment/structure. A plastic tarp/Visqueen lining with no seams shall be placed under the equipment and over the edges of the sandbags, or a plastic hazardous materials secondary containment unit shall be utilized by the Contractor.
- The Contractor will be required to conduct vehicle refueling in upland areas where fuel cannot enter waters of the U.S. and in areas that do not have potential to support federally threatened or endangered species. Any fuel containers, repair materials, including creosote-treated wood, and/or stockpiled material that is left on site overnight, will be secured in secondary containment within the work area and staging/assembly area and covered with plastic at the end of each work day.
- In the event that no activity is to occur in the work area for the weekend and/or a period of time greater than 48 hours, the Contractor will ensure that all portable fuel containers are removed from the project site.
- All equipment will be maintained in accordance with manufacturer's recommendations and requirements.
- Equipment and containers will be inspected daily for leaks. Should a leak occur, contaminated soils and surfaces will be cleaned up and disposed of following the guidelines identified in the Stormwater Pollution Prevention Plan or equivalent, Materials Safety Data Sheets, and any specifications required by other permits issued for the project.
- The Contractor will utilize off-site maintenance and repair shops as much as possible for maintenance and repair of equipment.
- If maintenance of equipment must occur onsite, fuel/oil pans, absorbent pads, or appropriate containment will be used to capture spills/leaks within all areas. Where feasible, maintenance of equipment will occur in upland areas where fuel cannot enter waters of the U.S. and in areas that do not have potential to support federally threatened or endangered species.
- Appropriate BMPs will be used by the Contractor to control erosion and sedimentation and to capture debris and contaminants from bridge construction to prevent their deposition in waterways. No sediment or debris will be allowed to enter the creek or other drainages. All debris from construction of the bridge will be contained so that it does not fall into channel. Appropriate BMPs will be used by the Contractor during construction to limit the spread of resuspended sediment and to contain debris.

- Erosion and sediment control devices used for the proposed project, including fiber rolls and bonded fiber matrix, will be made from biodegradable materials such as jute, with no plastic mesh, to avoid creating a wildlife entanglement hazard.
- Firearms, open fires, and pets would be prohibited at all work locations and access roads. Smoking would be prohibited along the Project alignment.
- Cross-country vehicle and equipment use outside of approved designated work areas and access roads shall be prohibited to prevent unnecessary ground and vegetation disturbance.
- Any injured or dead wildlife encountered during project-related activities shall be reported to the project biologist, biological monitor, CDFW, or a CDFW-approved veterinary facility as soon as possible to report the observation and determine the best course of action. For special-status species, the Project Biologist shall notify the County, USFWS, and/or CDFW, as appropriate, within 24 hours of the discovery.
- Stockpiling of material will be allowed only within established work areas.
- Actively manage the spread of noxious weeds
- The ground beneath all parked equipment and vehicles shall be inspected for wildlife before moving.

BIO-3

Worker Environmental Awareness Program. Prior to project construction, a Worker Environmental Awareness Program shall be developed and implemented by a qualified biologist and shall be available in both English and Spanish. Handouts summarizing potential impacts to special-status biological resources and the potential penalties for impacts to these resources shall be provided to all construction personnel. At a minimum, the education program shall include the following:

- The purpose for resource protection;
- A description of special-status species including representative photographs and general ecology;
- Occurrences of USACE, RWQCB, and CDFW regulated features in the Project study area;
- Regulatory framework for biological resource protection and consequences if violated
- Sensitivity of the species to human activities;
- Avoidance and minimization measures designed to reduce the impacts to special-status biological resources;
- Environmentally responsible construction practices;
- Reporting requirements;
- The protocol to resolve conflicts that may arise at any time during the construction process; and

- Workers sign acknowledgement form indicating that the Environmental Awareness Training and Education Program that has been completed and would be kept on record

BIO-4

Burrowing Owl Avoidance and Minimization. Take Avoidance (pre-construction) surveys for burrowing owl shall be completed prior to project construction. Surveys shall be conducted as detailed within Appendix E of the Staff Report on Burrowing Owl Mitigation (California Department of Fish and Game [CDFG] 2012). If burrowing owl is not detected, construction may proceed.

- If burrowing owl is identified during the non-breeding season (September 1 through January 31), then a 50-meter buffer will be established by the biological monitor. Construction within the buffer will be avoided until a qualified biologist determines that burrowing owl is no longer present or until a CDFW-approved exclusion plan has been implemented. The buffer distance may be reduced if noise attenuation buffers such as hay bales are placed between the occupied burrow and construction activities.
- If burrowing owl is identified during the breeding season (February 1 through August 31), then an appropriate buffer will be established by the biological monitor in accordance with the *Staff Report on Burrowing Owl Mitigation* (CDFG 2012). Construction within the buffer will be avoided until a qualified biologist determines that burrowing owl is no longer present or until young have fledged. The buffer distance may be reduced in consultation with CDFW if noise attenuation buffers such as hay bales are placed between the occupied burrow and construction activities.

BIO-5

Pre-Construction Nesting Bird Survey. If construction or other project activities are scheduled to occur during the bird breeding season (typically February 1 through August 31 for raptors and March 15 through August 31 for the majority of migratory bird species), a pre-construction nesting-bird survey shall be conducted by a qualified avian biologist to ensure that active bird nests, including those for the black-tailed gnatcatcher, northern harrier, yellow warbler, burrowing owl, and loggerhead strike, will not be disturbed or destroyed. The survey shall be completed no more than three days prior to initial ground disturbance. The nesting-bird survey shall include the project site and adjacent areas where project activities have the potential to affect active nests, either directly or indirectly due to construction activity or noise. If an active nest is identified, the biologist shall establish an appropriately sized disturbance-limit buffer around the nest using flagging or staking. Construction activities shall not occur within any disturbance-limit buffer zones until the nest is deemed inactive by the qualified biologist. If construction activities cease for a period of greater than three days during the bird breeding season, a pre-construction nesting bird survey shall be conducted prior to the commencement of activities. Final construction buffers or setback distances shall be determined by the qualified biologist in coordination with USFWS and CDFW on a case-by-case basis, depending on the species, season in which disturbance shall occur, the type of disturbance, and other factors that could influence susceptibility to disturbance (topography, vegetation, existing disturbance levels, etc.).

BIO-6 Pre-Construction Survey for Special-Status Species. A pre-construction survey shall be conducted for special-status wildlife species within all areas of potential permanent and temporary disturbance. The pre-construction survey shall take place no more than 14 days prior to the start of ground-disturbing activities. The pre-construction surveys should take place regardless of breeding season timing and shall focus on identifying the presence of special-status wildlife species present on the project site or that were identified as having a high potential to occur on the site. These species include, but are not limited to, flat-tailed horned lizard, burrowing owl, northern harrier, black-tailed gnatcatcher, and yellow warbler. Should any special-status species be identified during the pre-construction survey, consultation to develop suitable avoidance and minimization measures with the appropriate agency (USFWS, CDFW) may need to be undertaken.

BIO-7 Bat Acoustic Surveys and Monitoring. To avoid impacts to bat species, a qualified bat biologist shall conduct an appropriate combination of sampling, exit counts, and acoustic surveys to determine if bats are using the palm tree resources in the project area. If project-related impacts to bat species are unavoidable, additional measures may need to be implemented to reduce or eliminate impacts to bat species, including maternity roosts, such as tree removal occurring outside of bat breeding season (October through February) or two-step, two-day removal of palm trees under supervision of a qualified bat biologist.

Significance After Mitigation

Project construction has the potential to directly impact special-status wildlife species. However, implementation of Mitigation Measures BIO-1 through BIO-7 would reduce potential impacts to a less than significant level.

Impact 3.5-2 Would the project have a substantial adverse effect on any riparian habitat or other sensitive natural community identified in local or regional plans, policies, regulations or by the CDFW or USFWS?

SOLAR ENERGY FACILITY, BATTERY STORAGE SYSTEM, AND GEN-TIE LINE

RIPARIAN HABITAT

Both riparian habitat and disturbed riparian habitat are present within the project site. They are associated with the floodplain adjacent to the wetlands and drainages throughout the site. A total of 5.8 acres of riparian habitat and 8.22 acres of disturbed riparian habitat exists within the project site. The proposed project has been designed to avoid impacts to the riparian habitat and disturbed riparian habitat on the project site. As shown on the Site Plan (Figure 2-3), project components would not be sited on the project site where riparian habitat and disturbed riparian habitats are present. Solar panels, structures, and new access roads will not be placed within 50 feet of wetland and riparian habitat boundaries. Therefore, the proposed project would have no impact on riparian habitats.

SENSITIVE NATURAL COMMUNITIES

Tamarisk thicket occurs within the project site and is considered a sensitive natural community by CDFW. The proposed project has been designed to avoid impacts to this sensitive natural community. As shown on the Site Plan (Figure 2-3), project components would not be sited on the project site

where tamarisk thickets are present. Implementation of the project would result in no impact on sensitive natural communities.

CONSTRUCTION ACCESS ROAD

The existing dirt access road is on urban/developed land. No riparian habitat or sensitive natural communities are located within or adjacent to the access road. Therefore, the use of the access road during construction would have no impact on riparian or sensitive natural communities.

Mitigation Measure(s)

No mitigation is required.

Impact 3.5-3 Would the project have a substantial adverse effect on state or federally-protected wetlands (including but not limited to, marsh, vernal pool, coastal, etc.) through direct removal, filing, hydrological interruption, or other means?

SOLAR ENERGY FACILITY, BATTERY STORAGE SYSTEM, AND GEN-TIE LINE

The *Aquatic Resources Delineation Report* prepared for the project (Appendix E of this EIR) identified 11 aquatic resources on the project site and access road (see Table 3.5-2 and Figure 3.5-12 through Figure 3.5-17). The proposed project has been designed to avoid impacts to aquatic resources. As shown on the Site Plan (Figure 2-3), project components would not be sited on the project site where aquatic resources are present. Implementation of the project would result in no impact on state or federally protected aquatic resources.

CONSTRUCTION ACCESS ROAD

The existing dirt access road is on urban/developed land. No aquatic resources are located within or adjacent to the access road. Therefore, the use of the access road during construction would have no impact on riparian or sensitive natural communities.

Mitigation Measure(s)

No mitigation is required.

Impact 3.5-4 Would the project interfere substantially with the movement of any native resident or migratory fish and wildlife species or with established native resident or migratory wildlife corridors, or impede the use of native wildlife nursery sites?

SOLAR ENERGY FACILITY, BATTERY STORAGE SYSTEM, AND GEN-TIE LINE

The project site is located adjacent to areas containing existing disturbances (i.e., roads, border wall, and active agricultural land). The majority of the project site does not contain suitable vegetation and/or cover to support wildlife movement and is nestled on the edge of agricultural and development; therefore, wildlife movement opportunities connecting the project site to large, undeveloped natural areas is extremely limited. Wildlife will be able to continue to use the riparian habitat and surrounding agricultural lands as a potential corridor and nursery site. The proposed project is not expected to significantly impact wildlife movement through the project vicinity and a less than significant impact would occur.

ACCESS ROAD

The existing dirt access road is on urban/developed land. Therefore, the use of the access road during construction would have no impact on wildlife movement.

Mitigation Measure(s)

No mitigation is required.

Impact 3.5-5 Would the project conflict with any local policies or ordinances protecting biological resources, such as a tree preservation policy or ordinance?

SOLAR ENERGY FACILITY, BATTERY STORAGE SYSTEM, AND GEN-TIE LINE

The proposed project consists of the construction and operation of a solar energy facility and associated electrical transmission lines. Development of the solar facility is subject to the County's zoning ordinance.

The project site is located on three privately owned legal parcels zoned Heavy Agriculture with a Renewable Energy Zone Overlay (A-3-RE). Pursuant to Title 9, Division 5, Chapter 9, "Solar Energy Plants" and "Transmission lines, including supporting towers, poles microwave towers, utility substations" are uses that are permitted in the A-3 Zone, subject to approval of a CUP from Imperial County.

As demonstrated in Table 3.5-3 and discussed further in Section 3.11 Land Use Planning, with approval of a CUP, the project would be consistent with Imperial County General Plan, and with biological resources policies contained therein. Therefore, implementation of the proposed project would not result in a significant impact associated with the project's potential to conflict with local policies protecting biological resources.

CONSTRUCTION ACCESS ROAD

The use of the access road during construction is not anticipated to result in potential impacts on biological resources because vehicles and construction equipment would be required to stay within the existing boundaries of the dirt road to avoid and/or minimize ground disturbance to undisturbed and vegetated areas. Furthermore, the project applicant would not make improvements to the existing dirt road except for the application of water for dust suppression. Based on these considerations, the use of the access road during construction would not conflict with local policies protecting biological resources.

Mitigation Measure(s)

No mitigation is required.

Impact 3.5-6 Would the project conflict with the provisions of an adopted Habitat Conservation Plan, Natural Community Conservation Plan, or other approved local, regional, or state habitat conservation plan?

SOLAR ENERGY FACILITY, BATTERY STORAGE SYSTEM, AND GEN-TIE LINE

The project site is not located in a Habitat Conservation Plan, Natural Community Conservation Plan, or other approved local, regional, or state habitat conservation plan. Implementation of the proposed project would result in no impact associated with the potential to conflict with local conservation plans.

CONSTRUCTION ACCESS ROAD

The construction access road is not located in a Habitat Conservation Plan, Natural Community Conservation Plan, or other approved local, regional, or state habitat conservation plan. Therefore, the use of the access road during construction would result in no impact associated with the potential to conflict with local conservation plans.

Mitigation Measure(s)

No mitigation is required.

3.5.4 Decommissioning/Restoration and Residual Impacts

Decommissioning/Restoration

If at the end of the PPA term, no contract extension is available for a power purchaser, no other buyer of the energy emerges, or there is no further funding of the project, the project will be decommissioned and dismantled. Project decommissioning activities will require construction vehicles to drive across the solar facility, transmission line, and access roads. Concrete footings, foundations, and pads would be removed using heavy equipment and recycled at an off-site location. All remaining components would be removed, and all disturbed areas would be reclaimed and recontoured. Similar to project construction, decommissioning activities have the potential to directly impact special-status species. Nesting birds and burrowing owl could occupy the project site as well as habitat abutting the access roads or gen-tie line. Adjacent native habitats could be degraded by the introduction of invasive species or by wildlife caused by construction activities. These impacts could be significant. However, implementation of Mitigation Measures BIO-1 through BIO-7 at the time of decommissioning would reduce impacts to a level less than significant.

Residual

The project does not impact state or federally protected wetlands, does not conflict with any local policies or ordinances protecting biological resources and does not conflict with the provisions of an adopted Habitat Conservation Plan, Natural Community Conservation Plan, or other approved local, regional, or state habitat conservation plan.

With the implementation of Mitigation Measures BIO-1 through BIO-7, potential impacts to special-status species would be reduced to a level less than significant.

Therefore, the project would not result in residual significant and unmitigable impacts related to biological resources.

This page is intentionally blank.

3.6 Cultural Resources

This section discusses cultural resources that may be potentially impacted by the proposed project. The following identifies the existing cultural resources within the project site, analyzes potential impacts of the proposed project, and recommends mitigation measures to avoid or reduce potential impacts of the proposed project.

Information for this section is summarized from the Cultural Resources Inventory prepared by ECORP Consulting, Inc. This report is included in Appendix F of this EIR. The cultural resources inventory included a records search, literature review, and field survey.

The Area of Potential Effects (APE), or project area, consists of the horizontal and vertical limits of a project and includes the area within which significant impacts to historical resources or historic properties could occur as a result of the project. The APE is defined for projects subject to regulations implementing Section 106 (federal law and regulations). For projects subject to CEQA and for the purposes of this EIR, the term “project area” is used rather than APE.

The horizontal limit of the project area includes areas proposed for construction, vegetation removal, grading, trenching, stockpiling, staging, and paving. The horizontal limit of the project area measures approximately 528 acres. It should be noted that the project applicant re-designed the project to remove the western parcel (APN 059-209-010) after the completion of the Cultural Resources Inventory Report and field survey. This re-design reduced the original project site to 450 acres. The Cultural Resources Inventory Report and field survey covered the original project footprint.

The vertical limit of the project area is described as the maximum depth below the surface to which excavations for project foundations and facilities will extend. Therefore, the vertical limit includes all subsurface areas where archaeological deposits could be affected. The subsurface vertical limit varies across the project, depending on the depth of the grading or trenching for installation of facilities. The Cultural Resources Inventory assumes it could extend as deep as 10 feet below the current surface; therefore, review of geologic and soils maps was necessary to determine the potential for buried archaeological sites that cannot be seen on the surface.

The vertical limit also is described as the maximum height of structures that could impact the physical integrity and integrity of setting of cultural resources, including districts and traditional cultural properties. The Cultural Resources Inventory assumes the above-surface vertical limit is up to 30 feet above the surface.

3.6.1 Existing Conditions

Cultural Setting

Regional Pre-contact History

EARLY HOLOCENE (10,000-6,500 BP) AND MIDDLE HOLOCENE (6,500-3,500 BP)

The Salton Trough area of the Colorado Desert has little archaeological material dating to the Early and Middle Holocene. The only indications of use of this area during this period of time consist of large bifacial dart points found on relic lake beds of Lake Cahuilla and on desert pavement. These include projectile point types common in the Mojave Desert such as Lake Mojave, Pinto, and Elko. The sparse occupation during the Middle Holocene may be related to extremely arid climatic conditions and of the lack of water in the Salton Trough (absence of Lake Cahuilla). The Salton Sea Naval Test Base study

has produced evidence for Archaic occupation on the west side of the Salton Trough. Pinto and Elko series projectile points recovered during investigations at the Test Base yielded a date of 5,840 ±250 years BP. This data suggests that the desert area of southeastern California was not entirely abandoned during the Middle Holocene. While the population of the region was probably sparse, small bands of mobile people most likely moved among areas where water (at springs) and plant food resources were available (Appendix F of this EIR).

LATE ARCHAIC PERIOD (3,000 TO 1,300 BP)

A few temporary camps with living surfaces and hearths dating to the period 3,000 to 1,300 BP (Late Archaic Period) are located away from the lakebed in canyons and in the upper Coachella Valley above the maximum lake level. However, two temporary camps dating to the first millennium BC that contain fish and waterfowl bone in the Coachella Valley along the maximum Lake Cahuilla shoreline indicate there may have been a lake stand during this period (Appendix F of this EIR).

LATE PERIOD (1,300 BP TO CONTACT)

Higher population and greater numbers of sites appear to correlate with the presence of Lake Cahuilla, which filled the Salton Trough when water flowed into the trough from the Colorado River. When water ceased to flow from the river, the lake dried, markedly reducing the availability of resources. When the lake was present, lacustrine resources such as fish, shellfish, and waterfowl were available. When the lake was absent, very few resources were available and human population was low. To the northwest, in the Coachella Valley, the intermittent Whitewater River entered Lake Cahuilla near Point Happy between what is now Indian Wells and Indio. Several late pre-contact archaeological sites have been investigated along the ancient Lake Cahuilla shoreline in this area. To the south, the entire Imperial Valley between East Mesa and West Mesa was underwater when Lake Cahuilla was present (Appendix F of this EIR).

The southern part of the Salton Trough was occupied by ancestors of the Yuman-speaking Tipai, Kumeyaay, or Kamia. This area included the Imperial Valley, the Yuha Desert, and the mountains to the west and east. The lower Colorado River area was occupied by ancestors of the Yuman-speaking Quechan. However, Late Prehistoric archaeological sites in this area belong to the Patayan. Patayan I begins about 1,300 BP and is indicated archaeologically by the presence of small arrow points and by the appearance of Black Mesa Buff and Colorado Beige ceramics along the Colorado River. Patayan ceramics first appeared about 1,200 BP on the east shore of Lake Cahuilla and were probably introduced by Yuman people from the Colorado River. Within other areas of the the southern Salton Trough, ceramics first appear about 1,000 BP at the beginning of Patayan II. Later Patayan II (AD 1000 – 1700) and III (AD 1700 – 1850) ceramics include Tumco Buff and Colorado Buff.

Along the lower Colorado River, the Patayan settlement-subsistence system consisted of horticulture, hunting, and gathering in riparian habitats. People lived in multi-seasonal residential bases along the river. When Lake Cahuilla was present in the Salton Trough, they also occupied temporary camps for fishing, hunting, and gathering on the eastern shore of Lake Cahuilla. On the west side of the Salton Trough, the Patayan pattern consisted of a seasonal round among upland and lowland habitats. When Lake Cahuilla was present, seasonal residential bases and temporary camps were occupied on the western shore of Lake Cahuilla in order to obtain lacustrine resources including fish, shellfish, and waterfowl.

During the Late Period, the northern part of the Salton Trough (northern Salton Sea area and the Coachella Valley) was occupied by ancestors of the Takic-speaking Cahuilla. They also occupied the adjacent Santa Rosa and San Jacinto mountains. Floral remains indicated use of these sites during

all four seasons. These large multi-seasonal residential bases were likely occupied during the three Lake Cahuilla lake stands between AD 1200 and 1680, along the ancient shorelines in the Coachella Valley. These sites also contain abundant fish bone, waterfowl bone, and shell from freshwater shellfish which indicate use of both lowland and upland resources. Typical artifacts at these sites include cottonwood and desert side-notched arrow points, buff ware ceramics, and late pre-contact marine shell beads.

The Colorado Desert area northeast of the Salton Trough, including the Chuckwalla Valley area, was probably used intermittently prior to AD 1200 by small groups of Yuman-speaking hunter-gatherers who had residential bases or villages along the Colorado River. These sites would consist of small temporary camps and lithic scatters. Ancestors of the Numic-speaking Chemehuevi moved into the southeastern Mojave Desert and northeastern Colorado Desert (including Chuckwalla Valley) on the west side of the Colorado River about AD 1200. Because the Chemehuevi did not have access to the Colorado River Valley, which was still occupied by Yuman speakers, their use of the desert area was more intensive. Therefore, temporary camps used by ancestors of the Chemehuevi as well as lithic scatters, should be larger than those dating prior to AD 1200. Pottery is present in some of the temporary camps and consists of either locally made brown ware or buff ware that was obtained through trade with the Colorado River groups.

Obsidian from the Obsidian Butte source on the southeast margin of the Salton Sea was used for making flaked-stone tools throughout southern California during the Late Period. However, obsidian from Obsidian Butte could only be obtained when lake levels were low, since it is at an elevation of -40 meters (130 feet) below sea level. It is possible that the Imperial Valley Yumans traded obsidian for food resources from other groups when lacustrine resources from Lake Cahuilla were not available. Exchange patterns are also indicated by the presence of numerous marine shell beads (made in the coastal Chumash area) in late pre-contact Takic-speaking Cahuilla sites, but not in Yuman-speaking areas.

Ethnohistory

The Kumeyaay (also known as Ipai and Tipai) are the Yuman-speaking native people of central and southwestern Imperial County, central and southern San Diego County, and the northern Baja Peninsula in Mexico. The ancestral lands of the Kumeyaay extend north from Todos Santos Bay near Ensenada, Mexico to Agua Hedionda Lagoon in north San Diego County, and east to the Imperial Valley. Village locations were selected for seasonal use and were occupied by exogamous, patrilineal clans or bands. Kumeyaay lived in residential bases during the winter and subsisted on stored resources. No permanent houses were built. Brush shelters were temporary and were not reused the next year. Ceremonies, including rites of passage and ceremonies were held in the winter residential bases. The Kumeyaay were geographically and linguistically divided into western and eastern Kumeyaay. The western Kumeyaay lived along the coast and in the valleys along the drainages west of the mountains. The eastern Kumeyaay lived in the canyons and desert east of the mountains. The eastern and western Kumeyaay met in the mountains in the fall, where they gathered black oak acorns, traded, and held ceremonies (Appendix F of this EIR).

Beginning in 1775, the seminomadic life of the Kumeyaay began to change as a result of contact with Euro-Americans, particularly from the influence of the Spanish missions. Through successive Spanish, Mexican, and Anglo-American control, the Kumeyaay were forced to adopt a sedentary lifestyle and accept Christianity.

Regional History

In September of 1771, Father Francisco Garcés followed the Gila River west to its confluence with the Colorado River, traveled south to the Laguna de Salada in Baja California, then turned northwest until he reached the southern end of Imperial Valley. Garcés and his party were the first Europeans to see the Salton Sink region. After his return to Mexico, Garcés talked of his discovery to Captain Juan Bautista de Anza, the commander of the Spanish presidio at Tubac, in what is now southern Arizona. Anza wrote to the Viceroy of Mexico, Antonio María Bucareli Ursúa, and received permission to mount an expedition to cross the Colorado River into California. The Anza expedition crossed the Colorado River near Yuma, entering the Colorado Desert. Rather than crossing or skirting the extensive sand dunes that lie west of Yuma, Anza followed the river south into Baja California, then turned north. After about three weeks of hardship, the expedition reached Imperial Valley west of the future site of Calexico. After crossing Borrego Valley and the Santa Rosa Mountains, Anza and his men reached Mission San Gabriel in Los Angeles on March 22, 1774, having become the first Europeans to cross the Colorado Desert and what would later be known as Imperial Valley (Appendix F of this EIR).

The first proposal to irrigate the Colorado Desert for agriculture came from Dr. Oliver M. Wozencraft after he saw Indians cultivating plots during an exploratory trip in May of 1849. Wozencraft secured the rights to 1,600 square miles of desert land in the Salton Sink from the California Legislature in 1859 with engineer Charles R. Rockwood directing operations. In 1891, the Colorado River Irrigation Company was formed. In 1896, Rockwood formed the California Development Company and Canadian capitalist George Chaffey, the founder of Ontario, California, provided funding and promotion for the company in 1900. By 1902, the Central Main Canal (Imperial Canal) had been built and water began flowing from the Colorado River just south of the U.S.-Mexico border, via the Alamo River, to the canal.

Agricultural development of the sink as a result of irrigation and real estate promotion by Chaffey and the California Development Company exceeded expectations. The population of 2,000 in 1902 grew to 7,000 by 1903 and to more than 10,000 by 1904; and from little or no cultivation in 1900, agriculture in the Salton Sink grew to 120,000 acres under cultivation by January of 1905. During the winter of 1904-1905, greater than usual rainfall in the watershed area of the Gila River caused a high rate of discharge into the Colorado River and resulted in the clogging of canal intake systems with a disproportionate amount of silt. After four floods, the Alamo River-Imperial Canal system overflowed, and the entire discharge of the Colorado River began to pour into the Salton Sink, creating the Salton Sea. Agricultural development resumed in Imperial Valley after the flooding of the Salton Sea was brought under control in early 1907.

With the increasing acreage under irrigation and cultivation, and the Southern Pacific Railroad reaching southward all the way through Imperial and El Centro to Calexico, the population of Imperial Valley and the region surrounding it had grown to around 20,000 by 1907. After prominent Imperial Valley citizens petitioned for Imperial Valley to be separated from the County of San Diego, a vote was held on August 6, 1907; and on August 12, 1907, Imperial County was created. Although Imperial was the first city to be established and incorporated in the region, El Centro was chosen by election to be the county seat later that year.

The IID was established in July 1911 and was the largest irrigation district in the world at that time, covering an area of 817 square miles. In June 1916, the IID purchased the canal system built by the California Development Company. Today, the IID provides water for 6,471 square miles in Imperial Valley and is the most extensive irrigation district in the U.S. Agriculture, dairy farming, and cattle raising have been the economic staples of Imperial Valley since the early twentieth century. Although



the Great Depression of the 1930s brought hardships to the area, it also brought many agricultural workers from the Oklahoma dust bowl who became permanent residents. The completion of Boulder (Hoover) Dam on the Colorado River in 1935, and the All-American Canal from the river to Imperial Valley in 1940, increased and secured the region’s irrigation water supply, solidifying the Imperial Valley’s economy.

Records Search

A records search from the South Coastal Information Center (SCIC) of the CHRIS at San Diego State University was requested on September 15, 2020, to determine the extent of previous surveys within a 1-mile of the project area, and whether previously documented pre-contact or historic-period archaeological sites, architectural resources, or traditional cultural properties exist within this area.

Previous Research

On September 21, 2020, the results from the CHRIS records search revealed that 12 previous cultural resources investigations have been conducted within 1 mile of the project area between 1973 and 2001. Eight previous cultural resources investigations overlap the project area, and the records search indicates that portions of the project area have been previously surveyed as part of a cultural resources technical study. Though portions of the project area were previously surveyed, these surveys took place more than 19 years ago under obsolete standards. The length of time that has passed between the prior surveys and the present necessitated a resurvey of the project area. A list of previous cultural resources investigations of the project area is provided in the Cultural Resources Inventory (Appendix F of this EIR).

Previously Recorded Resources

The CHRIS records search determined that six previously recorded cultural resources are located within 1 mile of the project area. Previously recorded resources comprise two historic-period canals, one historic-period bridge, one international boundary monument, one multicomponent precontact ceramic scatter/historic-period refuse deposit, and one pre-contact temporary camp with habitation debris. One previously recorded resource, an historic-period refuse deposit, is located within the project area. Table 3.6-1 details of all seven previously recorded resources.

Table 3.6-1. Previously Recorded Cultural Resources Within 1-Mile of the Project Area

Site No.	Description	NRHP/CRHR Eligibility	Within Project Area?
CA-IMP-000319	Temporary camp with habitation debris	Not Eligible	No
CA-IMP-007130	All-American Canal	Eligible for listing in the NRHP	No
CA-IMP-007835	East Highline Canal	Not Eligible	No
CA-IMP-008050	Historic-period refuse scatter; Precontact ceramic scatter	Not Eligible	No
None	Bridge #58-140	Not Eligible	No

Table 3.6-1. Previously Recorded Cultural Resources Within 1-Mile of the Project Area

Site No.	Description	NRHP/CRHR Eligibility	Within Project Area?
CA-IMP-008660	Historic-period refuse deposit	Not Eligible	Yes
None	International Border Monument #217	Not Eligible	No

Source: Appendix F of this EIR

The National Register Information System did not list any eligible or listed properties within the project area or one-mile vicinity. Additionally, no resources were identified as listed as California Historical Landmarks and by the OHP. One resource, the All-American Canal, has been previously evaluated as eligible for listing on the NRHP.

A search of historic General Land Office land patent records was also conducted and revealed nine historic-period resources in the project area. Additional details on these nine resources are provided in the Cultural Resources Inventory (Appendix F of this EIR).

Field Survey

Between October 5 and 12, 2020, a pedestrian survey was conducted on the project area under the guidance of the *Secretary of the Interior's Standards for the Identification of Historic Properties*. The pedestrian survey was conducted by walking north-south transects across all accessible portions of the property and examining both permeable and impermeable surfaces throughout. During the survey, exposed ground surfaces were examined for indications of surface or subsurface cultural resources. The general morphological characteristics of the ground surface were inspected for indications of subsurface deposits that may be manifested on the surface, such as circular depressions or ditches.

The entire project area is currently undeveloped. However, large portions of the project area have previously been utilized for agriculture. Additionally, evidence of previous vegetation removal efforts is visible, and the eastern quarter of the project area has been staked out with surveyor's lath. Minimally disturbed native surfaces exist in the western third of the project area. Visible soil is all native soils that are either periodically inundated, undisturbed, or disturbed by agricultural or vegetation removal activities within the project area.

One previously recorded resource was relocated and updated as part of this study and 16 newly identified cultural resources were found during the field survey (Table 3.6-2). Newly identified cultural resources comprise of pre-contact and historic-period resources.



Table 3.6-2. Updated and Newly Recorded Resources within the Project Area

Temporary or Primary No.	Age/Period	Description	NRHP Eligibility	CRHR Eligibility
P-13-009597	Historic	Refuse deposit	NE under all criteria	NE under all criteria
2020-142-001	Historic	Refuse deposit	TE under A, B, D	TE under 1, 2, and 4
2020-142-002	Historic	Refuse deposit	TE under A, B, D	TE under 1, 2, and 4
2020-142-004	Historic	Refuse deposit	TE under A, B, D	TE under 1, 2, and 4
2020-142-005	Pre-contact	Ceramic and lithic scatter	TE under D	TE under 4
2020-142-006-I	Pre-contact	Ceramic isolate	NE under all criteria	NE under all criteria
2020-142-007-I	Pre-contact	Ceramic and lithic isolate	NE under all criteria	NE under all criteria
2020-142-008	Pre-contact	Ceramic and lithic scatter with historic isolates	TE under D	TE under 4
2020-142-017-I	Pre-contact	Ceramic isolate	NE under all criteria	NE under all criteria
2020-142-018-I	Historic	Can isolate	NE under all criteria	NE under all criteria
2020-142-019	Pre-contact	Ceramic and lithic scatter	NE under all criteria	NE under all criteria
2020-142-020-I	Pre-contact	Lithic isolate	NE under all criteria	NE under all criteria
2020-142-021	Historic	Agricultural irrigation equipment	NE under all criteria	NE under all criteria
2020-142-022	Pre-contact	Ceramic and lithic scatter	NE under all criteria	NE under all criteria
2020-142-023-I	Pre-contact	Ceramic isolate	NE under all criteria	NE under all criteria
2020-142-024-I	Pre-contact	Lithic isolate	NE under all criteria	NE under all criteria
2020-142-025	Historic	Agricultural irrigation equipment	NE under all criteria	NE under all criteria

Source: Appendix F of this EIR

Notes: TE = Treated as Eligible; NE = Evaluated and Found Not Eligible

Historical Resources

Historical resources significant under CEQA include those designated or eligible for designation in the NRHP, the CRHR or other state program, or a local register of historical resources. Historical resources may also include resources listed in the State Historic Resources Inventory as significant at the local level or higher, and resources evaluated as potentially significant in a survey or other professional evaluation.

As shown in Table 3.6-2, a total of 17 cultural resources were identified within the project area: five historic-period sites, two pre-contact (prehistoric) sites, three multi-component sites (with pre-contact and historic-period elements), six pre-contact isolates, and one historic-period isolate.

As a result of the inventory and evaluations, out of the 17 total cultural resources identified within the project area, five cultural resources are being treated as eligible for the NRHP as historic properties under Section 106 and eligible for the CRHR as historical resources under CEQA. These five cultural resources are described in detail below, including a discussion of their NRHP and CRHR eligibility considerations. The NRHP and CRHR eligibility criteria are described below.

- **NRHP Eligibility Criteria.** Four criteria have been established to determine if a resource is significant to American history, architecture, archaeology, engineering, or culture and should be listed in the NRHP. These criteria include:
 - A. It is associated with events that have made a significant contribution to the broad patterns of our history;
 - B. It is associated with the lives of persons significant in our past;
 - C. It embodies the distinctive characteristics of a type, period, or method of construction or that represent the work of a master, or that possess high artistic values, or that represent a significant and distinguishable entity whose components may lack individual distinction; and
 - D. It yields, or may be likely to yield, information important in prehistory or history.
- **CRHR Eligibility Criteria.** For the purposes of CEQA review, a historical resource is defined as follows (14 CCR 15064.5[a]):
 1. A resource listed in, or determined eligible by the State Historical Resources Commission for listing in, the California Register of Historical Resources (CRHR)
 2. A resource included in a local register of historical resources
 3. A resource identified as significant in a historical resource survey meeting the requirements specified in PRC 5024.1(g)
 4. Any resource that the lead agency determines to be historically significant

Historic-Period Refuse Scatter: Site 2020-142-001

Site 2020-142-001 consists of historic-period refuse deposits in three distinct concentrations, measuring a total of 44 meters long and 29 meters wide. Within these concentrations, hundreds of glass and metal can fragments, boot heels, and a fragmented license plate were observed. Variations in maker marks within the concentrations suggest bottles were produced in the first half of the 20th century, some before the 1930s.

ELIGIBILITY CONSIDERATION

Archival research may reveal a connection between this site and an important event or person in history. Artifacts onsite suggest that there may be present archaeological deposits that are temporally diagnostic, which may be able to provide important information in history. This site is hereby being treated as eligible for NRHP, without testing, under Criteria A, B and D and for CRHR under Criteria 1, 2, and 4 for the purposes of this project alone.

Historic-Period Refuse Scatter: Site 2020-142-002

Site 2020-142-002 consists of historic-period metal and glass refuse in two concentrations, with additional refuse scattered between and around them measuring a total of 40 meters long and 32 meters wide. Artifacts consist primarily of domestic and personal consumption artifacts, such as miscellaneous metal fragments and cans, and colorless, cobalt, green, milk, amber, aqua, and amethyst glass. Ammunition casings of .45 Colt (also referred to as Long Colt) were observed on and within the vicinity of the site. A diagnostic glass bottle base located between the two concentrations dates to between 1906 and 1914.

Concentration 1 consists of more than 100 miscellaneous metal and can fragments, glass jar/bottle fragments, and glazed historic-period ceramic fragments. Diagnostic bottle bases within this concentration date between 1915 and 1929.

Concentration 2 is a smaller deposit consisting of similar glass and can fragments. A diagnostic bottle base within this concentration dates between 1934 to ca. 1968.

ELIGIBILITY CONSIDERATION

Archival research may reveal a connection between this site and an important event or person in history. Artifacts onsite suggest that there may be present archaeological deposits that are temporally diagnostic, which may be able to provide important information in history. This site is hereby being treated as eligible for NRHP, without testing, under Criteria A, B, and D and for CRHR under Criteria 1, 2 and 4 for the purposes of this project alone.

Historic-Period Refuse Scatter: Site 2020-142-004

Site 2020-142-004 consists of a single historic-period refuse deposit measuring 16 meters long by 12 meters wide. The site includes miscellaneous metals (non-diagnostic), glazed ceramics, approximately 75 crockery fragments, and fragments of various glass colors including at least 50 aqua, five green, over 150 colorless, 20 sun-colored amethyst, five cobalt, and two milk glass. Miscellaneous metals include .45 Colt casings and a brass belt buckle.

ELIGIBILITY CONSIDERATION

Archival research may reveal a connection between this site and an important event or person in history. Artifacts onsite suggest that there may be present archaeological deposits that are temporally diagnostic, which may be able to provide important information in history. This site is hereby being treated as eligible for NRHP, without testing, under Criteria A, B and D and for CRHR under Criteria 1, 2 and 4 for the purposes of this project alone.

Pre-Contact Ceramic and Lithic Scatter: Site 2020-142-005

Site 2020-142-005 consists of a pre-contact artifact scatter comprised of ceramic fragments, one lithic fragment, and one isolated historic-period glass bottle base, measuring 65 meters long by 65 meters

wide. Over 100 sherds of precontact ceramics were counted, three of which were rim sherds, including Greyware, buff, Tizon brown ware, and redware.

ELIGIBILITY CONSIDERATION

Several of the ceramic artifacts at this site may have temporally diagnostic markers that can be associated with a specific event or pattern of events marking an important moment in pre-contact history. This site is hereby treated as eligible for NRHP, without testing, under Criterion D and CRHR under Criterion 4 for the purposes of this project alone.

Pre-Contact Ceramic and Lithic Scatter and Historic-Period Isolate: Site 2020-142-008

This pre-contact site consists of six discrete concentrations (Concentration 1 through Concentration 6) of ceramic scatter and several lithic artifacts, located along a westward-facing terrace above the 11.9-meter (40-foot) elevation eastern shore of Lake Cahuilla. An approximate total of 300 ceramic sherds and 10 fragments of lithic debitage are present within this site. An isolated historic-period .30-06 cartridge case manufactured in the Twin Cities Ordnance Plant in 1942 was also identified within the site boundary. Overall, the site size measures 290 meters long and 105 meters wide.

ELIGIBILITY CONSIDERATION

Several of the ceramic artifacts at this site may have temporally diagnostic markers that can be associated with a specific event or pattern of events marking an important moment in pre-contact history. This site is hereby treated as eligible for NRHP, without testing, under Criterion D and CRHR under Criterion 4 for the purposes of this project alone.

3.6.2 Regulatory Setting

This section identifies and summarizes federal, state, and local laws, policies, and regulations that are applicable to the project.

Federal

National Historic Preservation Act

Federal regulations (36 CFR Part 800.2) define historic properties as "any prehistoric or historic district, site, building, structure, or object included, or eligible for inclusion in, in the National Register of Historic Places." Section 106 of the National Historic Preservation Act (NHPA) (Public Law 89-665; 80 Stat 915; USC 470, as amended) requires a federal agency with jurisdiction over a project to take into account the effect of the project on properties included in or eligible for the (NRHP, and to afford the Advisory Council on Historic Preservation a reasonable opportunity to comment. The term "cultural resource" is used to denote a historic or prehistoric district, site, building, structure, or object, regardless of whether it is eligible for the NRHP.

State

California Office of Historic Preservation

The California Office of Historic Preservation (OHP) administers state and federal historic preservation programs and provides technical assistance to federal, state, and local government agencies, organizations, and the general public with regard to historic preservation programs designed to identify, evaluate, register, and protect California's historic resources.

Section 15064.5 of the CEQA Guidelines also requires that Native American concerns and the concerns of other interested persons and corporate entities, including but not limited to museums, historical commissions, associations, and societies be solicited as part of the process of cultural resources inventory. In addition, California law protects Native American burials, skeletal remains, and associated grave goods regardless of their antiquity and provides for the sensitive treatment and disposition of those remains (HSC Section 7050.5, PRC Sections 5097.94 et seq.).

CEQA Guidelines: Historical Resources Definition

CEQA Guidelines Section 15064.5(a) defines a historical resource as:

- (1) A resource listed in, or determined to be eligible by the State Historical Resources Commission, for listing in the CRHR (PRC Section 5024.1; Title 14 CCR, Section 4850 et seq.).
- (2) A resource included in a local register of historical resources, as defined in Section 5020.1(k) of the Public Resources Code or identified as significant in an historical resource survey meeting the requirements Section 5024.1(g) of the Public Resources Code, shall be presumed to be historically or culturally significant. Public agencies must treat any such resource as significant unless the preponderance of evidence demonstrates that it is not historically or culturally significant.
- (3) Any object, building, structure, site, area, place, record, or manuscript which a lead agency determines to be historically significant or significant in the architectural, engineering, scientific, economic, agricultural, educational, social, political, military, or cultural annals of California may be considered to be an historical resource, provided the lead agency's determination is supported by substantial evidence in light of the whole record. Generally, a resource shall be considered by the lead agency to be "historically significant" if the resource meets the criteria for listing on the CRHR (PRC Section 5024.1; Title 14 CCR, Section 4852) including the following:
 - (A) Is associated with events that have made a significant contribution to the broad patterns of California's history and cultural heritage;
 - (B) Is associated with the lives of persons important to our past;
 - (C) Embodies the distinctive characteristics of a type, period, region, or method of construction, or represents the work of an important creative individual, or possesses high artistic values; or
 - (D) Has yielded, or may be likely to yield, information important in prehistory or history.¹
- (4) The fact that a resource is not listed in, or determined to be eligible for listing in the CRHR, not included in a local register of historical resources (pursuant to Section 5020.1(k) of the Public Resources Code), or identified in an historical resources survey (meeting the criteria in Section 5024.1(g) of the Public Resources Code) does not preclude a lead agency from determining that the resource may be an historical resource as defined in Public Resources Code Sections 5020.1(j) or 5024.1.

¹ Ibid.

CEQA Guidelines: Archaeological Resources

Section 15064.5(c) of CEQA Guidelines provides specific guidance on the treatment of archaeological resources as noted below.

- (1) When a project will impact an archaeological site, a lead agency shall first determine whether the site is an historical resource, as defined in subdivision (a).
- (2) If a lead agency determines that the archaeological site is an historical resource, it shall refer to the provisions of Section 21084.1 of the Public Resources Code, and this section, Section 15126.4 of the Guidelines, and the limits contained in Section 21083.2 of the Public Resources Code do not apply.
- (3) If an archaeological site does not meet the criteria defined in subdivision (a), but does meet the definition of a unique archeological resource in Section 21083.2 of the Public Resources Code, the site shall be treated in accordance with the provisions of Section 21083.2. The time and cost limitations described in Public Resources Code Section 21083.2 (c–f) do not apply to surveys and site evaluation activities intended to determine whether the project location contains unique archaeological resources.
- (4) If an archaeological resource is neither a unique archaeological nor an historical resource, the effects of the project on those resources shall not be considered a significant effect on the environment. It shall be sufficient that both the resource and the effect on it are noted in the Initial Study or EIR, if one is prepared to address impacts on other resources, but they need not be considered further in the CEQA process.

CEQA Guidelines: Human Remains

Section 15064.5 of CEQA Guidelines provides specific guidance on the treatment of human remains pursuant to PRC § 5097.98, which provides specific guidance on the disposition of Native American burials (human remains), and fall within the jurisdiction of the NAHC:

- (d) When an initial study identifies the existence of, or the probable likelihood, of Native American human remains within the project, a lead agency shall work with the appropriate Native Americans as identified by the NAHC as provided in Public Resources Code Section 5097.98. The applicant may develop an agreement for treating or disposing of, with appropriate dignity, the human remains and any items associated with Native American burials with the appropriate Native Americans as identified by the NAHC. Action implementing such an agreement is exempt from:
 - (1) The general prohibition on disinterring, disturbing, or removing human remains from any location other than a dedicated cemetery (HSC Section 7050.5).
 - (2) The requirements of CEQA and the Coastal Act.
- (e) In the event of the accidental discovery or recognition of any human remains in any location other than a dedicated cemetery, the following steps should be taken:
 - (1) There shall be no further excavation or disturbance of the site or any nearby area reasonably suspected to overlie adjacent human remains until:
 - (A) The coroner or the county in which the remains are discovered must be contacted to determine that no investigation of the cause of death is required, and
 - (B) If the coroner determines the remains to be Native American:

1. The coroner shall contact the NAHC within 24 hours.
 2. The NAHC shall identify the person or persons it believes to be the most likely descended from the deceased Native American.
 3. The mostly descendent may make recommendations to the landowner of the person responsible for the excavation work, for means of treating or disposing of, with appropriate dignity, the human remains and any associated grave goods as provided in Public Resources Code section 5097.98, or
- (2) Where the following conclusions occur the landowner or his authorized representative shall rebury the Native American human remains and associated grave goods with appropriate dignity on the property in a location not subject to further subsurface disturbance.
- (A) The NAHC is unable to identify a most likely descendent or the most likely descendent failed to make a recommendation within 24 hours after being notified by the commission.
- (B) The descendant fails to make a recommendation; or
- (C) The landowner or his authorized representative rejects the recommendation of the descendant, and the mediation by the NAHC fails to provide measures acceptable to the landowner.
- (f) As part of the objectives, criteria, and procedures required by Section 21082 of the Public Resources Code, a lead agency should make provisions for historical or unique archaeological resources accidentally discovered during construction. These provisions should include an immediate evaluation of the find by a qualified archaeologist. If the find is determined to be an historical or unique archaeological resource, contingency funding and a time allotment sufficient to allow for implementation of avoidance measures or appropriate mitigation should be available. Work could continue on other parts of the building site while historical or unique archaeological resource mitigation takes place.”

California Health and Safety Code, Section 7050.5

California HSC 7050.5 makes it a misdemeanor to disturb or remove human remains found outside a cemetery. This code also requires a project owner to halt construction if human remains are discovered and to contact the County Coroner.

Local

Imperial County General Plan

The Imperial County General Plan provides goals, objectives, and policies for the identification and protection of significant cultural resources. The Conservation and Open Space Element of the General Plan includes goals, objectives, and policies for the protection of cultural resources and scientific sites that emphasize identification, documentation, and protection of cultural resources. While Section 3.11, Land Use Planning, of this EIR analyzes the project’s consistency with the General Plan pursuant to CEQA Guidelines Section 15125(d), the Imperial County Board of Supervisors and Planning Commission ultimately make a determination as to the project’s consistency with the General Plan. Goals and Objectives applicable to the proposed project are summarized in Table 3.6-3.

Table 3.6-3. Project Consistency with Applicable General Plan Goals and Objectives

General Plan Policies	Consistency with General Plan	Analysis
<p>Conservation and Open Space Element - Open Space and Recreation Conservation</p> <p>Goal 1 - Environmental resources shall be conserved for future generations by minimizing environmental impacts in all land use decisions and educating the public on their value.</p> <p>Objective 1.4 - Ensure the conservation and management of the County's natural and cultural resources.</p>	Consistent	<p>A cultural resources inventory was prepared for the project area. Known archaeological resources within the project area will be avoided and not impacted. However, as discussed below, the proposed project has the potential to encounter undocumented historical, archaeological resources, and human remains.</p> <p>Implementation of Mitigation Measure CR-1 would ensure avoidance of five historical resources on the project site. With implementation of Mitigation Measure CR-2, potential impacts to previously unrecorded cultural resources would be reduced to a level less than significant. Implementation of Mitigation Measure CR-3 would reduce the potential impact associated with the inadvertent discovery of archaeological resources to a level less than significant. Mitigation Measure CR-4 would ensure that the potential impact on previously unknown human remains does not rise to the level of significance pursuant to CEQA.</p>
<p>Objective 3.1 - Protect and preserve sites of archaeological, ecological, historical, and scientific value, and/or cultural significance.</p>	Consistent	<p>Implementation of Mitigation Measure CR-1 would ensure avoidance of five historical resources on the project site. With implementation of Mitigation Measure CR-2, potential impacts to previously unrecorded cultural resources would be reduced to a level less than significant. Implementation of Mitigation Measure CR-3 would reduce the potential impact associated with the inadvertent discovery of archaeological resources to a level less than significant. Mitigation Measure CR-4 would ensure that the potential impact on previously unknown human remains does not rise to the level of significance pursuant to CEQA.</p>

Source: County of Imperial 1993

Notes:

CR=cultural resource

3.6.3 Impacts and Mitigation Measures

This section presents the significance criteria used for considering proposed project impacts related to cultural and archeological resources, the methodology employed for the evaluation, an impact evaluation, and mitigation requirements, if necessary.

Thresholds of Significance

Based on CEQA Guidelines Appendix G, project impacts related to cultural resources are considered significant if any of the following occur:

- Cause a substantial adverse change in the significance of a historical resource pursuant to §15064.5
- Cause a substantial adverse change in the significance of an archaeological resource pursuant to §15064.5
- Disturb any human remains, including those interred outside of dedicated cemeteries

Methodology

This analysis evaluates the potential for the proposed project, as described in Chapter 2, Project Description, to interact with cultural resources in the project area. Based on the extent of these interactions, this analysis considers whether these conditions would result in an exceedance of one or more of the applied significance criteria as identified above.



As indicated in the environmental setting, a Cultural Resources Inventory (Appendix F of this EIR) was prepared for the project. The cultural resources inventory provides the results of a SCIC records search and a field survey which have been completed for the project area pursuant to CEQA.

The information from the cultural resources inventory was reviewed and summarized to present the existing conditions and to identify potential environmental impacts, based on the significance criteria presented in this section. Impacts associated with cultural resources that could result from project construction and operational activities were evaluated qualitatively based on site conditions; expected construction practices; materials, locations, and duration of project construction and related activities.

Impact Analysis

Impact 3.6-1 Would the project cause a substantial adverse change in the significance of a historical resource pursuant to §15064.5?

To be considered historically significant, a resource must meet one of four criteria for listing outlined in the CRHR (CEQA Guidelines 15064.3 (a)(3)). In addition to meeting one of the criteria outlined the CRHR, a resource must retain enough intact and undisturbed deposits to make a meaningful data contribution to regional research issues (CCR Title 14, Chapter 1.5 Section 4852 [c]). Further, based on CEQA Guidelines Section 15064.5 (b), substantial adverse change would include physical demolition, destruction, relocation, or alteration of the resource or its immediate surroundings such that the significance of an historical resource is materially impaired. This can occur when a project:

- Demolishes or materially alters in an adverse manner those physical characteristics of an historical resource that convey its historical significance and that justify its inclusion in, or eligibility for, inclusion in the CRHR, NRHP, a local register, or historic resources.
- Demolishes or materially alters in an adverse manner those physical characteristics that account for its identification in an historical resources survey meeting the requirements of PRC §5024.1(g), unless the public agency establishes by a preponderance of the evidence that the resource is not historically or culturally significant.

SOLAR ENERGY FACILITY, BATTERY STORAGE SYSTEM, AND GEN-TIE LINE

As a result of the inventory and evaluations, out of the 17 total cultural resources identified within the project area, the following five cultural resources are being treated as eligible for listing in the CRHR as historical resources under CEQA.

- Historic-Period Refuse Scatter: Site 2020-142-001 (CRHR Criteria 1, 2, and 4)
- Historic-Period Refuse Scatter: Site 2020-142-002 (CRHR Criteria 1, 2, and 4)
- Historic-Period Refuse Scatter: Site 2020-142-004 (CRHR Criteria 1, 2, and 4)
- Pre-Contact Ceramic and Lithic Scatter: Site 2020-142-005 (CRHR Criterion 4)
- Pre-Contact Ceramic and Lithic Scatter and Historic-Period Isolate: Site 2020-142-008 (CRHR Criterion 4)

The proposed project has been designed to avoid Sites 2020-142-001, 2020-142-002, 2020-142-004, 2020-142-005, and 2020-142-008. To ensure avoidance of Sites 2020-142-001, 2020-142-002, 2020-142-004, 2020-142-005, and 2020-142-008, Mitigation Measure CR-1 will be implemented. Mitigation Measure CR-1 requires the installation of orange environmentally sensitive area (ESA) fencing or flagging around the boundaries of each of the resources prior to any construction activity and shall

remain in place throughout project construction. The placement of the ESA flagging or fencing will be done under the supervision of a qualified archaeologist (to be retained by the project applicant). No project activity (including equipment staging, transportation, vegetation removal, or construction or other crews standing or walking) shall occur within the ESA boundaries of the sites. Implementation of Mitigation Measure CR-1 would reduce impacts on historical resources to a level less than significant.

Given the number of resources identified within the project area, there is a potential to unearth previously unknown cultural resources. In the event that unknown cultural resources are discovered during project construction, significant impacts could occur. However, with implementation of Mitigation Measure CR-2, potential impacts to previously unrecorded cultural resources would be reduced to a level less than significant.

ACCESS ROAD

During construction, vendors and heavy construction equipment would access the project site via Gordon Wells Road approximately 20 miles east of the project site, then travel west along an existing dirt road paralleling the U.S./Mexico Border. This existing dirt road is actively used by the U.S. Border Patrol during patrol operations. The use of this access road during construction is not anticipated to result in potential impacts on cultural resources because vehicles and construction equipment would be required to stay within the existing boundaries of the dirt road to avoid and/or minimize ground disturbance to undisturbed and vegetated areas. Furthermore, the project applicant would not make improvements to the existing dirt road except for the application of water for dust suppression. No grading or excavation would occur to the dirt road as a result of the project. Based on these considerations, the potential to impact cultural resources is considered low and a less than significant impact would occur.

Mitigation Measure(s)

CR-1 Environmentally Sensitive Area Fencing. Prior to issuance of grading permits and in coordination with a qualified archaeologist to be retained by the project applicant, the construction zone shall be narrowed or otherwise altered to avoid Sites 2020-142-001, 2020-142-002, 2020-142-004, 2020-142-005, and 2020-142-008. The area within 100 feet of Sites 2020-142-001, 2020-142-002, 2020-142-004, 2020-142-005, and 2020-142-008 shall be designated Environmentally Sensitive Area (ESA) and fenced or flagged with exclusion markers to ensure avoidance. Protective fencing shall not identify the protected area as a cultural resource area in order to discourage unauthorized disturbance or collection of artifacts. The ESA fencing or flags shall remain in place throughout project construction.

CR-2 Evaluate Significance of Find (Unknown Cultural Resources). If subsurface deposits believed to be cultural in origin are discovered during construction, all work must halt within a 100-foot radius of the discovery. A qualified professional archaeologist who meets the Secretary of the Interior's Standards for prehistoric and historic archaeology and is familiar with the resources of the region, shall be retained to evaluate the significance of the find, and shall have the authority to modify the no work radius as appropriate, using professional judgment. The following notifications shall apply, depending on the nature of the find:

- If the professional archaeologist determines that the find does not represent a cultural resource, work may resume immediately, and no agency notifications are required.
- If the professional archaeologist determines that the find does represent a cultural resource from any time period or cultural affiliation, he or she shall immediately notify

the Imperial County Planning and Development Services Department. The Imperial County Planning and Development Services Department shall consult with the professional archaeologist on a finding of eligibility and implement appropriate treatment measures if the find is determined to be an Historical Resource under CEQA, as defined in Section 15064.5(a) of the CEQA Guidelines, or an Historic Property, as defined in 36 CFR 60.4. Work may not resume within the no-work radius until the Imperial County Planning and Development Services Department, through consultation as appropriate, determine that the site either: 1) is not an Historical Resource under CEQA or an Historic Property under Section 106; or 2) that the treatment measures have been completed to their satisfaction.

Impact 3.6-2 Would the project cause a substantial adverse change in the significance of an archaeological resource pursuant to §15064.5?

Pursuant to CEQA Guidelines §15064.5(c)(1) and (2), an archaeological resource includes an archaeological site that qualifies as a significant historical resource as described for Impact 3.6-1. If an archaeological site does not meet any of the criteria outlined in the provisions under Impact 3.6-1 but meets the definition of a “unique archaeological resource” in PRC 21083.2, the site shall be treated in accordance with the provisions of PRC 21083.2, unless the project applicant and public agency elect to comply with all other applicable provisions of CEQA with regards to archaeological resources. “Unique archaeological resource” means an archaeological artifact, object or site about which it can be clearly demonstrated that, without merely adding to the current body of knowledge, there is a high probability that it meets any of the following criteria:

- 1) Contains information needed to answer important scientific research questions that there is a demonstrable public interest in that information.
- 2) Has a special and particular quality such as being the oldest of its type or the best available example of its type.
- 3) Is directly associated with a scientifically recognized important historic event or person.

CEQA Guidelines 15064.5(c)(4) confirms that if an archaeological resource is neither a unique archaeological nor an historic resource, the effects of the project on those resources shall not be considered a significant effect on the environment.

SOLAR ENERGY FACILITY, BATTERY STORAGE SYSTEM, AND GEN-TIE LINE

Based on a review of historic aerial photographs and maps of the project area, the property was in use as agricultural land as early as 1953. Portions of the project area appear to have been used for agricultural purposes at varying times in photographs from 1953 to 1996. The property has undergone agricultural modification, tilling, and grading in past decades. These agricultural activities have likely heavily disturbed the surface and subsurface of the project area, destroying any intact potential prehistoric or historic-era cultural resources. The potential of finding a buried archaeological site during construction is considered low. However, like all construction projects in the state, the possibility exists. This potential impact is considered significant. Implementation of Mitigation Measure CR-3 would reduce the potential impact associated with the inadvertent discovery of archaeological resources to a level less than significant.

ACCESS ROAD

During construction, vendors and heavy construction equipment would access the project site via Gordon Wells Road approximately 20 miles east of the project site, then travel west along an existing

dirt road paralleling the U.S./Mexico Border. This existing dirt road is actively used by the U.S. Border Patrol during patrol operations. The use of this access road during construction is not anticipated to result in potential impacts on archaeological resources because vehicles and construction equipment would be required to stay within the existing boundaries of the dirt road to avoid and/or minimize ground disturbance to undisturbed and vegetated areas. Furthermore, the project applicant would not make improvements to the existing dirt road except for the application of water for dust suppression. No grading or excavation would occur to the dirt road as a result of the project. Based on these considerations, the potential to impact archaeological resources is considered low and a less than significant impact would occur.

Mitigation Measure(s)

CR-3 Evaluate Significance of Find (Unknown Archaeological Resources). In the event of the discovery of previously unidentified archaeological materials, the contractor shall immediately cease all work activities within approximately 100 feet of the discovery. After cessation of excavation, the contractor shall immediately contact the Imperial County Department of Planning and Development Services Department. Except in the case of cultural items that fall within the scope of the Native American Grave Protection and Repatriation Act, the discovery of any cultural resource within the project area shall not be grounds for a “stop work” notice or otherwise interfere with the project’s continuation except as set forth in this paragraph.

In the event of an unanticipated discovery of archaeological materials during construction, the applicant shall retain the services of a qualified professional archaeologist, meeting the Secretary of the Interior’s Standards for a Qualified Archaeologist, to evaluate the significance of the materials prior to resuming any construction-related activities in the vicinity of the find. If the qualified archaeologist determines that the discovery constitutes a significant resource under CEQA and it cannot be avoided, the applicant shall implement an archaeological data recovery program.

Impact 3.6-3 Would the project disturb any human remains, including those interred outside of dedicated cemeteries?

SOLAR ENERGY FACILITY, BATTERY STORAGE SYSTEM, AND GEN-TIE LINE

During the construction and operational phases of the proposed project, grading, excavation and trenching will be required. Although the potential for encountering subsurface human remains within the project site is low, there remains a possibility that human remains are present beneath the ground surface, and that such remains could be exposed during construction. The potential to encounter human remains is considered a significant impact. Mitigation Measure CR-4 would ensure that the potential impact on previously unknown human remains does not rise to the level of significance pursuant to CEQA.

ACCESS ROAD

During construction, vendors and heavy construction equipment would access the project site via Gordon Wells Road approximately 20 miles east of the project site, then travel west along an existing dirt road paralleling the U.S./Mexico Border. This existing dirt road is actively used by the U.S. Border Patrol during patrol operations. The use of this access road during construction is not anticipated to result in potential impacts on archaeological resources because vehicles and construction equipment would be required to stay within the existing boundaries of the dirt road to avoid and/or minimize ground disturbance to undisturbed and vegetated areas. Furthermore, the project applicant would not

make improvements to the existing dirt road except for the application of water for dust suppression. No grading or excavation would occur to the dirt road as a result of the project. Based on these considerations, the potential to encounter human remains is considered low and a less than significant impact would occur.

Mitigation Measure(s)

CR-4 Human Remains. If subsurface deposits believed to be human in origin are discovered during construction, all work must halt within a 100-foot radius of the discovery. A qualified professional archaeologist who meets the Secretary of the Interior’s Standards for prehistoric and historic archaeology and is familiar with the resources of the region, shall be retained to evaluate the significance of the find, and shall have the authority to modify the no work radius as appropriate, using professional judgment. The following notifications shall apply, depending on the nature of the find:

- If the find includes human remains, or remains that are potentially human, the professional archaeologist shall ensure reasonable protection measures are taken to protect the discovery from disturbance (AB 2641). The archaeologist shall notify the Imperial County Coroner (per § 7050.5 of the Health and Safety Code). The provisions of § 7050.5 of the California Health and Safety Code, § 5097.98 of the California PRC, and AB 2641 will be implemented.
- If the Coroner determines the remains are Native American and not the result of a crime scene, the Coroner will notify the NAHC, which then will designate a Native American Most Likely Descendant (MLD) for the project (§ 5097.98 of the PRC). The designated MLD will have 48 hours from the time access to the property is granted to make recommendations concerning treatment of the remains. If the landowner does not agree with the recommendations of the MLD, the NAHC may mediate (§ 5097.94 of the PRC). If no agreement is reached, the landowner must rebury the remains where they will not be further disturbed (§ 5097.98 of the PRC). This will also include either recording the site with the NAHC or the appropriate Information Center; using an open space or conservation zoning designation or easement; or recording a reinternment document with the county in which the property is located (AB 2641). Work may not resume within the no-work radius until the Imperial County Planning and Development Services Department, through consultation as appropriate, determine that the treatment measures have been completed to their satisfaction.

3.6.4 Decommissioning/Restoration and Residual Impacts

Decommissioning/Restoration

No impact is anticipated from restoration activities as the ground disturbance and associated impacts on cultural resources will have occurred during the construction phase of the proposed project.

Residual

Implementation of Mitigation Measure CR-1 would reduce potential impacts on historical resources to a level less than significant. With implementation of Mitigation Measure CR-2, potential impacts to previously unrecorded cultural resources would be reduced to a level less than significant. Implementation of Mitigation Measure CR-3 would reduce the potential impact associated with the

inadvertent discovery of archaeological resources to a level less than significant. Mitigation Measure CR-4 would ensure that the potential impact on previously unknown human remains does not rise to the level of significance pursuant to CEQA. No unmitigable impacts on cultural resources would occur with implementation of the proposed project.

3.7 Geology and Soils

This section includes an evaluation of the project in relation to existing geologic and soils conditions within the project site. Information contained in this section is summarized from the Preliminary Geological and Geotechnical Hazard Evaluation Report prepared by HDR. This report is included as Appendix G of this EIR.

3.7.1 Existing Conditions

Regional Geology

The project site is located in Imperial County in the Salton Trough portion of the Colorado Desert physiographic province. The Salton Trough is a topographic and geologic structural depression resulting from large scale regional faulting. The trough is bounded on the east and northeast by the San Andreas Fault and of the west by the San Jacinto Fault Zone. The Salton Trough represents the northward extension of the Gulf of California and contains more than 15,000 feet of Miocene and younger, marine and non-marine sediments capped by approximately 100 feet of Pleistocene and later lacustrine deposits as a result of intermittent filling derived from periodic flooding of the Colorado River and Lake Cahuilla (Appendix G of this EIR). Tectonic activity that formed the trough continues at a high rate as evidenced by deformed young sedimentary deposits and high levels of seismicity.

The geologic conditions present within the County contribute to a wide variety of hazards that can result in loss of life, bodily injury, and property damage. The primary seismic hazard at the project site is the potential for strong ground shaking. The project site is located within a highly active seismic zone. The nearest active major fault that poses a risk contribution of greater than 1 percent is the Imperial Fault, located approximately 2.36 miles (3.8 kilometers) west of the project site.

Surface Subgrade Soils and Groundwater Conditions

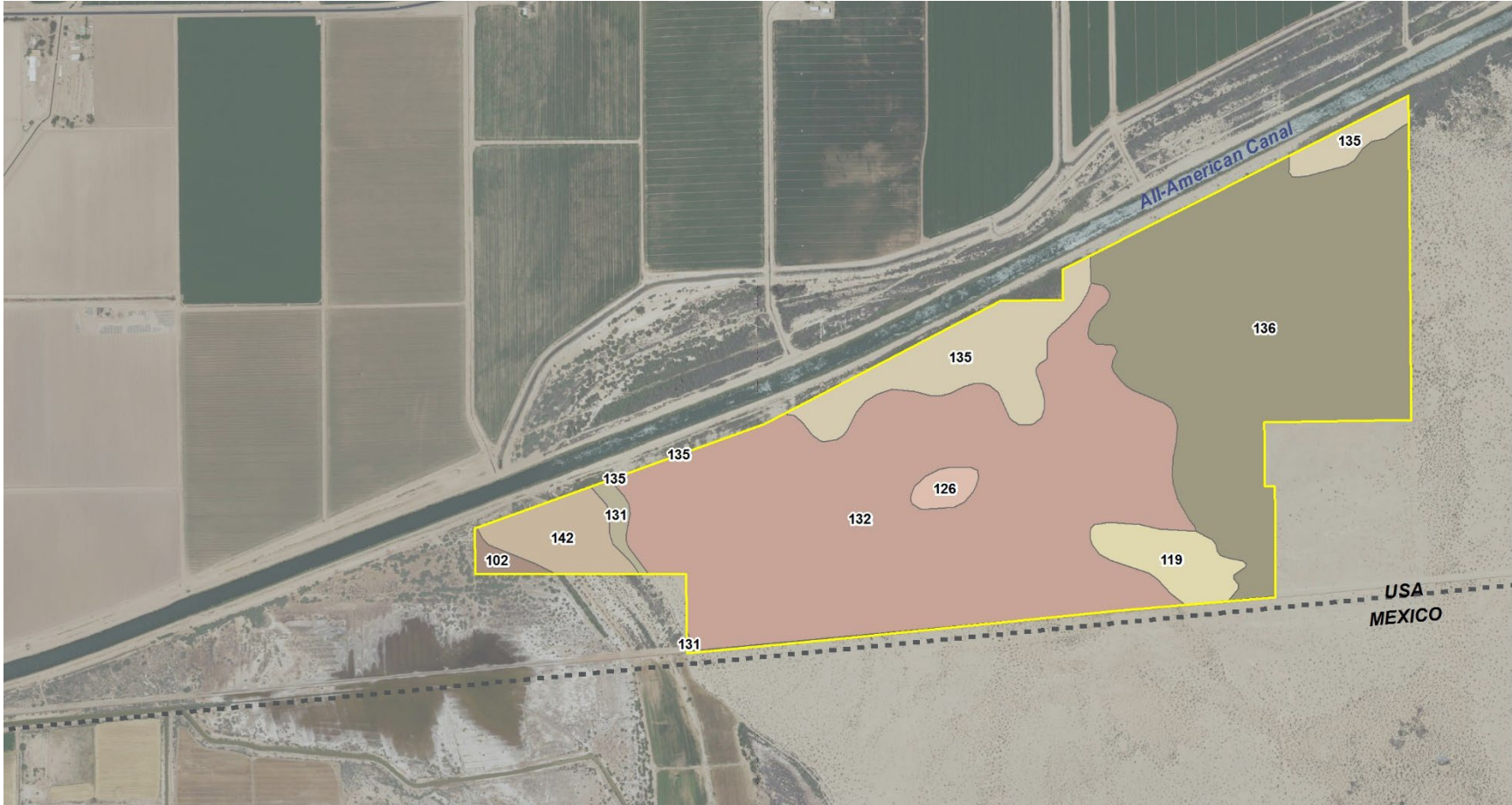
The project site is generally underlain by stratified alluvial deposits, predominately consisting of interbedded layers of silt, sand, and clay. The near-surface soils are predominantly comprised of very fine to fine sand and occasionally clay and silty clay (Appendix G of this EIR). As shown on Figure 3.7-1, soil series mapped on the project site include:

- 102 – Badland
- 119 – Indio-Vint complex
- 126 – Niland fine sand
- 131 – Rositas sand, 2 to 5 percent slope
- 132 – Rositas fine sand, 0 to 2 percent slopes
- 135 – Rositas fine sand, wet, 0 to 3 percent slopes
- 136 – Rositas loamy fine sand, 0 to 3 percent slopes
- 142 – Vint loamy very fine sand, wet

There are no known groundwater wells within a one-mile radius of the project site (Appendix G of this EIR).

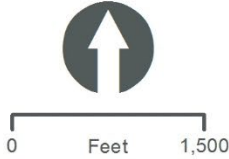
This page is intentionally blank.

Figure 3.7-1. Soils Mapped on the Project Site



Legend

- Project Boundary
- 102 - Badland
- 119 - Indio-Vint complex
- 126 - Niland fine sand
- 131 - Rositas sand, 2 to 5 percent slopes
- 132 - Rositas fine sand, 0 to 2 percent slopes
- 135 - Rositas fine sand, wet, 0 to 2 percent slopes
- 136 - Rositas loamy fine sand, 0 to 2 percent slopes
- 142 - Vint loamy very fine sand, wet



This page is intentionally blank



Faulting and Seismicity

Earthquakes are the result of an abrupt release of energy stored in the earth. This energy is generated from the forces which cause the continents to change their relative position on the earth's surface, a process called "continental drift." The earth's outer shell is composed of a number of relatively rigid plates which move slowly over the comparatively fluid molten layer below. The boundaries between plates are where the more active geologic processes take place. Earthquakes are an incidental product of these processes.

Southern California straddles the boundary between two global tectonic plates known as the North American Plate (on the east) and the Pacific Plate (on the west). The main plate boundary is represented by the San Andreas Fault, which extends northwest from the Gulf of California in Mexico, through the desert region of the Imperial Valley, through the San Bernardino region, and into Northern California, where it eventually trends offshore, north of San Francisco (Appendix G of this EIR).

In Southern California, the plate boundary is a complex system of numerous faults known as the San Andreas Fault System that spans a 150-mile-wide zone from the main San Andreas fault in the Imperial Valley westward to offshore of San Diego (Appendix G of this EIR).

The project site is located in the seismically active Southern California region, with numerous mapped faults traversing the region including the San Andreas, San Jacinto, and Elsinore Fault Zones. Under the current understanding of regional seismology and tectonics, the largest maximum earthquake to impact the project site would most likely be generated by the Imperial Fault (fault strand 5), which has an estimated maximum magnitude (M) of 7.3. Table 3.7-1 lists faults with a risk contribution greater than 1 percent at the project site (Appendix G of this EIR). Figure 3.7-2 identifies faults within the project region.

Table 3.7-1. Faults with a Risk Contribution of Greater than One Percent

Fault Name	Approximate Distance from Project Site (km)	Maximum Magnitude (M)
Imperial Fault [5]	3.8	7.3
Imperial Fault [6]	5.9	7.0
Imperial Fault [7]	10.4	6.9

Source: Appendix G of this EIR

Notes:

km=kilometers; M=Maximum magnitude; [] Fault strand

Seismic Ground Shaking

Ground shaking is the byproduct of an earthquake and is the energy created as rocks break and slip along a fault during an earthquake. The amount of ground shaking that an area may be subject to during an earthquake is related to the proximity of the area to the fault, the depth of the hypocenter (focal depth), location of the epicenter and the size (magnitude) of the earthquake. Soil type also plays a role in the intensity of shaking. Bedrock or other dense or consolidated materials are less prone to intense ground shaking than soils formed from alluvial deposition.

As the project site is located in the seismically active southern California region, strong ground shaking can be expected at the project site during moderate to severe earthquakes in the general region.

Surface Rupture

Surface rupture occurs when movement along a fault results in actual cracking or breaking of the ground along a fault during an earthquake; however, it is important to note that not all earthquakes result in surface rupture. Surface rupture almost always follows preexisting fault traces, which are zones of weakness. Rupture may occur suddenly during an earthquake or slowly in the form of fault creep. Fault creep is the slow rupture of the earth's crust. Sudden displacements are more damaging to structures because they are accompanied by shaking.

The California Geologic Survey (CGS) established criteria for faults as active, potentially active, and inactive. Active faults are those that show evidence of surface displacement within the last 11,000 years (Holocene age). Potentially active faults are those that demonstrate displacement within the past 1.6 million years (Quaternary age). Faults showing no evidence of displacement within the last 1.6 million years may be, in general, considered inactive for most structures, except for critical structures (Appendix G of this EIR).

In 1972 the Alquist-Priolo Special Studies Earthquake Hazards Act (APEHA) was passed, which required fault studies within 500 feet of active or potentially active faults. The APEHA designates "active" and "potentially active" faults utilizing the same age criteria as that used by the CGS. The project site is not located within a currently mapped APEHA zone. As previously mentioned above, the nearest active major fault is the Imperial fault located approximately 2.3 miles west of the project site (Appendix G of this EIR). Based on this distance, the potential for surface fault rupture to occur on the project site is considered low.

Liquefaction

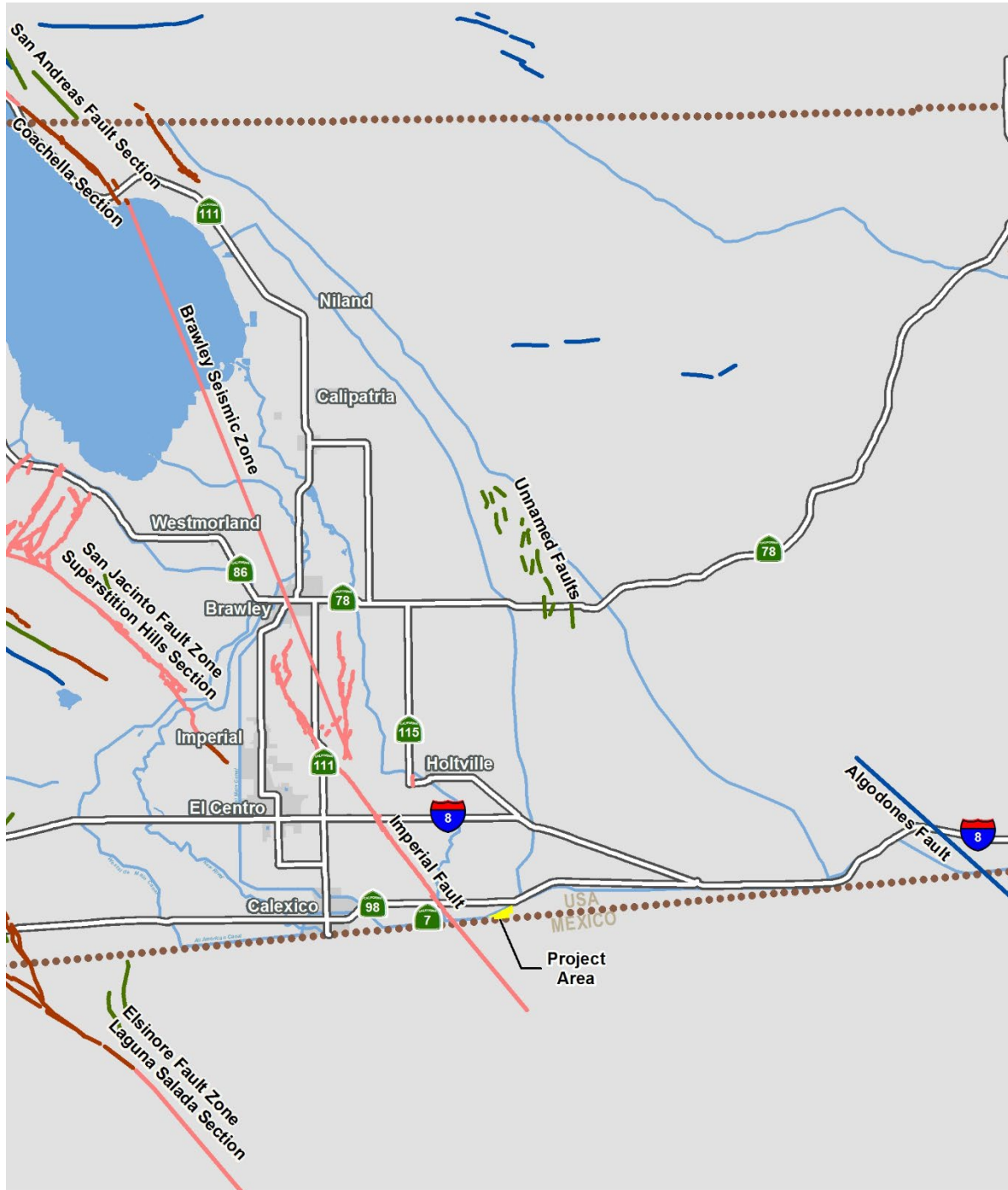
Liquefaction occurs when granular soil below the water table is subjected to vibratory motions, such as those produced by earthquakes. With strong ground shaking, an increase in pore water pressure develops as the soil tends to reduce in volume. If the increase in pore water pressure is sufficient to reduce the vertical effective stress (suspending the soil particles in water), the soil strength decreases, and the soil behaves as a liquid (similar to quicksand). The factors known to influence liquefaction potential include soil type, relative density, grain size distribution, confining pressure, depth to groundwater, and the intensity and duration of the seismic ground shaking. Liquefaction is most prevalent in loose- to medium-dense, silty, sandy, and gravelly soils below the groundwater table.

The project site has not been mapped for liquefaction potential by CGS (Appendix G of this EIR).

Landslides

Landslides are the descent of rock or debris caused by natural factors, such as the pull of gravity, fractured or weak bedrock, heavy rainfall, erosion, and earthquakes. The project site is relatively flat. Due to the existing topography, landslides are not considered a potential hazard for the project (Appendix G of this EIR).

Figure 3.7-2. Regional Fault Map



Legend

- VEGA SES 4 Project Area
- QT - Faults with undivided Quaternary displacement (last 1.6 million years)
- LTQT - Faults with late Quaternary displacement (last 750,000 years)
- HOL - Faults with Holocene displacement (last 11,000 years)
- HIS - Faults with historic displacement (last 200 years)



Lateral Spreading

Lateral spreading typically occurs as a form of horizontal displacement of relatively flat lying alluvial material toward an open or “free” face such as an open body of water, channel, or excavation. This movement is generally due to failure along a weak plane, and may often be associated with liquefaction. As cracks develop within the weakened material, blocks of soil displace laterally toward the open face. Cracking and lateral movement may gradually propagate away from the face as blocks continue to break free. It is unknown whether lateral spreading is a potential hazard on the project site.

Land Subsidence

Land subsidence is the sinking of the ground surface caused by the compression of earth materials or the loss of subsurface soil because of underground mining, tunneling, or erosion. The major causes of subsidence include fluid withdrawal from the ground, decomposing organics, underground mining or tunneling, and placing large fills over compressible earth materials. The effective stress on underlying soils is increased resulting in consolidation and settlement. Subsidence may also be caused by tectonic processes.

The project site is not located in an area of known ground subsidence or within any delineated zones of subsidence due to groundwater pumping or oil extraction. As such, the potential for subsidence at the project site is considered low (Appendix G of this EIR).

Expansive Soils

Expansive soils are characterized by their ability to undergo significant volume changes (shrink or swell) due to variations in moisture content. Changes in soil moisture content can result from precipitation, landscape irrigation, utility leakage, roof drainage, perched groundwater, drought, or other factors and may result in unacceptable settlement or heave of structures. The project site is underlain by sand, gravelly sand and clay/silty clay. Generally, sands are considered not expansive while soils and clays may exhibit moderate to high expansion potential due to variation in moisture content (Appendix G of this EIR).

Collapsible Soils

Collapsible soil is generally defined as soil that will undergo a sudden decrease in volume and its internal support is lost under applied loads when water is introduced into the soil. The internal support is considered to be a temporary strength and is derived from a number of sources including capillary tension, cementing agents, e.g. iron oxide and calcium carbonate, clay-welding of grains, silt bonds, clay bonds and clay bridges. Soils found to be most susceptible to collapse include loess (fine grained wind-deposited soils), valley alluvium deposited within a semi-arid to arid climate, and residual soil deposits. It is unknown whether collapsible soils are present on the project site.

Corrosive Soils

Corrosive soils can damage underground utilities including pipelines and cables, or weaken roadway structures. Generally, fine grained soils like clays are more likely to be corrosive (Appendix G of this EIR). Fine grained and potentially corrosive soils are expected to be encountered at the project site.

Paleontological Resources

Paleontological resources (fossils) are the remains of prehistoric plant and animal life. Fossil remains, such as bones teeth, shell, and wood, are found in geologic deposits (rock formations) within which they were originally buried. Many paleontological fossil sites are recorded in Imperial County and have been discovered during construction activities. Paleontological resources are typically impacted when earthwork activities, such as mass excavation cut into geological deposits (formations) with buried fossils.

The project site is in the Salton Basin near the shoreline of ancient Lake Cahuilla. The lake covered much of the Imperial Valley and created an extensive lacustrine environment. Lake Cahuilla experienced several fill recession episodes before it finally dried up about 300 years ago. In 1905, the Colorado River overflowed into the Salton Basin creating the present-day Salton Sea. As previously mentioned above, the project site is generally underlain by deposits from periodic flooding of the Colorado River and Lake Cahuilla (Appendix G of this EIR). Sediments from this formation have yielded fossilized remains of continental vertebrates, invertebrates, and plants at numerous previously recorded fossil sites in the Imperial Valley. Therefore, the project site is considered paleontologically sensitive.

3.7.2 Regulatory Setting

This section identifies and summarizes laws, policies, and regulations that are applicable to the project.

Federal

Earthquake Hazards Reduction Act

The Earthquake Hazards Reduction Act was enacted in 1977 to “reduce the risks to life and property from future earthquakes in the United States through the establishment and maintenance of an effective earthquake hazards and reduction program.” To accomplish this, the Act established the National Earthquake Hazards Reduction Program (NEHRP). This program was significantly amended in November 1990 by NEHRP, which refined the description of agency responsibilities, program goals, and objectives.

NEHRP’s mission includes improved understanding, characterization, and prediction of hazards and vulnerabilities; improvement of building codes and land use practices; risk reduction through post-earthquake investigations and education; development and improvement of design and construction techniques; improvement of mitigation capacity; and accelerated application of research results. The NEHRP designates the Federal Emergency Management Agency as the lead agency of the program and assigns it several planning, coordinating, and reporting responsibilities. Programs under NEHRP help inform and guide planning and building code requirements such as emergency evacuation responsibilities and seismic code standards such as those to which the project would be required to adhere.

State

Alquist-Priolo Special Studies Earthquake Hazards Act

The APEHA was passed into law following the destructive February 9, 1971, San Fernando earthquake. The APEHA provides a mechanism for reducing losses from surface fault rupture on a statewide basis. The intent of the APEHA is to ensure public safety by prohibiting the siting of most

structures for human occupancy across traces of active faults that constitute a potential hazard to structures from surface faulting or fault creep. The state geologist (Chief of the California Division of Mines and Geology) is required to identify “earthquake fault zones” along known active faults in California. Counties and cities must withhold development permits for human occupancy projects within these zones unless geologic studies demonstrate that there would be no issues associated with the development of projects. The project site is not located within a currently mapped APEHA zone.

California Building Code

The California Building Standards Commission is responsible for coordinating, managing, adopting, and approving building codes in California. CCR Title 24 is reserved for state regulations that govern the design and construction of buildings, associated facilities, and equipment, known as building standards. The California Building Code (CBC) is based on the Federal Uniform Building Code used widely throughout the country (generally adopted on a state-by-state or district-by-district basis). The California Health and Safety Code (HSC) Section and 18980 HSC Section 18902 give CCR Title 24 the name of California Building Standards Code. The updates to the 2019 California Building Standards Code were published on January 1, 2021, with an effective date of July 1, 2021.

Local

County of Imperial Land Use Ordinance

Title 9 Division 15 (Geological Hazards) of the County Land Use Ordinance has established procedures and standards for development within earthquake fault zones. Per County regulations, construction of buildings intended for human occupancy are prohibited across the trace of an active fault. An exception exists when such buildings located near the fault or within a designated Special Studies Zone are demonstrated through a geotechnical analysis and report not to expose a person to undue hazard created by the construction.

County of Imperial General Plan

The County of Imperial General Plan, Seismic and Public Safety Element identifies potential natural and human-induced hazards and provides policy to avoid or minimize the risk associated with hazards. The Seismic and Public Safety Element identifies ‘lifelines and critical facilities’ whose disruption could endanger the public safety. Lifelines are defined as networks of services that extend over a wide area and are vital to the public welfare, and can be classified into four categories: energy, water, transportation, and communications. The IID has a formal Disaster Readiness Standard Operating Procedure for the Water Department, Power Department, and the entire District staff for response to earthquakes and other emergencies.

Table 3.7-2 analyzes the consistency of the project with specific policies contained in the County of Imperial General Plan associated with geology, soils, and seismicity. While this EIR analyzes the project’s consistency with the General Plan pursuant to CEQA Guidelines Section 15125(d), the Imperial County Board of Supervisors ultimately determines consistency with the General Plan.



Table 3.7-2. Project Consistency with Applicable General Plan Policies

General Plan Policies	Consistency with General Plan	Analysis
Seismic and Public Safety Element		
Goal 1. Include public health and safety considerations in land use planning.	Consistent	Division 15 of the County Land Use Ordinance has established procedures and standards for development within earthquake fault zones. Per County regulations, construction of buildings intended for human occupancy which are located across the trace of an active fault are prohibited. An exception exists when such buildings located near the fault or within a designated Special Studies Zone are demonstrated through a geotechnical analysis and report not to expose a person to undue hazard created by the construction. Since the project site is located in a seismically active area, the project is required to be designed in accordance with the CBC for near source factors derived from a design basis earthquake based on a peak ground acceleration of 0.50 gravity. It should be noted that, the project would be remotely operated and would not require any habitable structures on site. In considering these factors in conjunction with mitigation requirements outlined in the impact analysis, the risks associated with seismic hazards would be minimized. A preliminary geotechnical report has been prepared for the proposed project. The preliminary geotechnical report has been referenced in this environmental document. Additionally, a design-level geotechnical investigation will be conducted to evaluate the potential for site specific hazards associated with seismic activity.
Objective 1.1. Ensure that data on geological hazards is incorporated into the land use review process, and future development process.		
Objective 1.3. Regulate development adjacent to or near all mineral deposits and geothermal operations.		
Objective 1.4. Require, where possessing the authority, that avoidable seismic risks be avoided; and that measures, commensurate with risks, be taken to reduce injury, loss of life, destruction of property, and disruption of service.		
Objective 1.7. Require developers to provide information related to geologic and seismic hazards when siting a proposed project.		
Goal 2: Minimize potential hazards to public health, safety, and welfare and prevent the loss of life and damage to health and property resulting from both natural and human-related phenomena.		
Objective 2.2. Reduce risk and damage due to seismic hazards by appropriate regulation.		
Objective 2.5 Minimize injury, loss of life, and damage to property by implementing all state codes where applicable.		
Objective 2.8 Prevent and reduce death, injuries, property damage, and economic and social dislocation resulting from natural hazards including flooding, land subsidence, earthquakes, other geologic phenomena, levee or dam failure, urban and wildland fires and building collapse by appropriate planning and emergency measures.		

Source: County of Imperial 1997

3.7.3 Impacts and Mitigation Measures

This section presents the significance criteria used for considering project impacts related to geologic and soil conditions, the methodology employed for the evaluation, an impact evaluation, and mitigation requirements, if necessary.

Thresholds of Significance

Based on CEQA Guidelines Appendix G, project impacts related to geology and soils are considered significant if any of the following occur:

- Directly or indirectly cause potential substantive adverse effects, including the risk of loss, injury, or death involving:
 - Rupture of a known earthquake fault, as delineated on the most recent AP Earthquake Fault Zoning Map issued by the state geologist for the area or based on other substantial evidence of a known fault; (Refer to Division of Mines and Geology Special Publication 42)
 - Strong seismic ground shaking
 - Seismic related ground failure, including liquefaction
 - Landslides
- Result in substantial soil erosion or the loss of topsoil
- Be located on a geologic unit or soil that is unstable or that would become unstable as a result of the project, and potentially result in on- or off-site landslide, lateral spreading, subsidence, liquefaction or collapse
- Be located on expansive soil, as defined in Table 18-1-B of the Uniform Building Code (1994), creating substantial direct or indirect risks to life or property
- Have soils incapable of adequately supporting the use of septic tanks or alternative wastewater disposal systems where sewers are not available for the disposal of wastewater
- Directly or indirectly destroy a unique paleontological resource or site or unique geologic feature

Methodology

This analysis evaluates the potential for the project, as described in Chapter 2, Project Description, to interact with local geologic and soil conditions on the project site. A preliminary geological and geotechnical hazard evaluation report was prepared for the project. The information obtained from the report was reviewed and summarized to present the existing geologic and soil conditions on the project site. This analysis considers whether these conditions would result in an exceedance of one or more of the applied significance criteria as identified above.

Impact Analysis

Impact 3.7-1 *Would the project directly or indirectly cause potential substantive adverse effects, including the risk of loss, injury, or death involving:*

Rupture of a known earthquake fault, as delineated on the most recent AP Earthquake Fault Zoning Map issued by the state geologist for the area or based on

other substantial evidence of a known fault; (Refer to Division of Mines and Geology Special Publication 42)?

As previously discussed above, the project site is located in the seismically active Imperial Valley of southern California with several mapped faults of the San Andreas Fault System traversing the region. As shown in Table 3.7-1, the project site is not located on an active fault. Furthermore, no portion of the project site is within a designated APEHA zone, and, therefore, the potential for ground rupture to occur within the project site is considered unlikely. Based on these considerations, the project would not directly or indirectly cause potential substantive adverse effects, including the risk of loss, injury, or death involving rupture of a known earthquake fault. This is considered a less than significant impact.

Mitigation Measure(s)

No mitigation measures are required.

Impact 3.7-2 Would the project directly or indirectly cause potential substantive adverse effects, including the risk of loss, injury, or death involving:

Strong seismic ground shaking?

As previously discussed above, the closest mapped fault to the project site is the Imperial Fault (fault strand 5), located approximately 2.36 miles west. In the event of an earthquake along this fault or another regional fault, seismic hazards related to ground motion could occur in susceptible areas within the project site. The intensity of such an event would depend on the causative fault and the distance to the epicenter, the moment magnitude, and the duration of shaking.

Even with the integration of building standards, ground shaking within the project site could cause some structural damage to the facility structures or, at least, cause unsecured objects to fall. During a stronger seismic event, ground shaking could result in structural damage or collapse of electrical distribution facilities. Given the potentially hazardous nature of the project facilities, the potential impact of ground motion during an earthquake is considered a significant impact, as proposed structures, such as the substation and transmission lines could be damaged. However, implementation of Mitigation Measure GEO-1, which requires preparation of a design-level geotechnical report, would reduce the potential impacts associated with ground shaking to a level less than significant.

Mitigation Measure(s)

GEO-1 Prepare Geotechnical Report(s) as Part of Final Engineering for the Project and Implement Required Measures. Facility design for all project components shall comply with the site-specific design recommendations as provided by a licensed geotechnical or civil engineer to be retained by the project applicant. The final geotechnical and/or civil engineering report shall address and make recommendations on the following:

- Site preparation
- Soil bearing capacity
- Appropriate sources and types of fill
- Potential need for soil amendments

- Structural foundations
- Grading practices
- Soil corrosion of concrete and steel
- Erosion/winterization
- Seismic ground shaking
- Liquefaction
- Expansive/unstable soils

In addition to the recommendations for the conditions listed above, the geotechnical investigation shall include subsurface testing of soil and groundwater conditions and shall determine appropriate foundation designs that are consistent with the version of the CBC that is applicable at the time building and grading permits are applied for. All recommendations contained in the final geotechnical engineering report shall be implemented by the project applicant. The final geotechnical and/or civil engineering report shall be submitted to Imperial County Public Works Department, Engineering Division for review and approval prior to issuance of building permits.

Significance after Mitigation

With implementation of Mitigation Measure GEO-1, potential impacts associated with strong seismic ground shaking would be reduced to a level less than significant with the implementation of recommendations made by a licensed geotechnical engineer in compliance with the CBC prepared as part of a formal geotechnical investigation.

Impact 3.7-3 Would the project directly or indirectly cause potential substantive adverse effects, including the risk of loss, injury, or death involving:

Seismic related ground failure, including liquefaction?

As previously discussed above, the factors known to influence liquefaction potential include soil type, relative density, grain size distribution, confining pressure, depth to groundwater, and the intensity and duration of the seismic ground shaking. Liquefaction is most prevalent in loose- to medium-dense, silty, sandy, and gravelly soils below the groundwater table. The project site has not been mapped for liquefaction potential by CGS (Appendix G of this EIR). However, given that the project site is underlain by sand and clay, there is a potential for liquefaction to occur on the project site. Additional geotechnical investigation would be required in order to assess the risk of liquefaction on the project site. The potential impact on liquefaction is considered a significant impact. Implementation of Mitigation Measure GEO-1, which requires the preparation of a design-level geotechnical report, would reduce the potential impact associated with liquefaction to a level less than significant.

Mitigation Measure(s)

No additional mitigation measures beyond Mitigation Measure GEO-1 are required.

Impact 3.7-4 Would the project directly or indirectly cause potential substantive adverse effects, including the risk of loss, injury, or death involving:

Landslides?

As stated above, the project site has a relatively flat topographic gradient. Therefore, the project would not directly or indirectly cause potential substantive adverse effects, including the risk of loss, injury, or death involving landslides and no impact would occur.

Mitigation Measure(s)

No mitigation measures are required.

Impact 3.7-5 Would the project result in substantial soil erosion or the loss of topsoil?

During the site grading and construction phases, large areas of unvegetated soil would be exposed to erosive forces by water for extended periods of time due to ICAPCD dust suppression requirements. Unvegetated soils are much more likely to erode from precipitation than vegetated areas because plants act to disperse, infiltrate, and retain water. Construction activities involving soil disturbance, excavation, cutting/filling, stockpiling, and grading activities could result in increased erosion and sedimentation to surface waters. Construction could produce sediment-laden stormwater runoff (nonpoint source pollution), a major contributor to the degradation of water quality. If precautions are not taken to contain contaminants, construction-related erosion impacts are considered a significant impact.

As provided in Mitigation Measure GEO-1, during final engineering for the project, a design-level geotechnical study would identify appropriate measures for the project related to soil erosion. In addition, as part of Mitigation Measure HYD-1 provided in Section 3.10 Hydrology/Water Quality, potential impacts from erosion during construction activities would be reduced to a level less than significant with the preparation of a SWPPP for sediment and erosion control and implementation of BMPs to reduce erosion from the construction site.

The project is not expected to result in substantial soil erosion or the loss of topsoil over the long term. The project applicant would be required to implement on-site erosion control measures in accordance with County standards, which require the preparation, review, and approval of a grading plan by the County Engineer. Therefore, with implementation of Mitigation Measure GEO-1 and Mitigation Measure HYD-1 identified in Section 3.10 Hydrology/Water Quality, impacts from construction-related erosion would be reduced to a level less than significant.

Mitigation Measure(s)

No additional mitigation measures beyond Mitigation Measure GEO-1 and Mitigation Measure HYD-1 are required.

Significance after Mitigation

With implementation of Mitigation Measure GEO-1 and Mitigation Measure HYD-1 in Section 3.10 Hydrology/Water Quality, potential impacts from erosion during construction activities would be reduced to a level less than significant with the preparation of a SWPPP and implementation of BMPs to reduce erosion from the construction site.

Impact 3.7-6 Would the project be located on a geologic unit or soil that is unstable or that would become unstable as a result of the project, and potentially result in on- or off-site landslide, lateral spreading, subsidence, liquefaction or collapse?

The potential for lateral spreading to occur on the project site has not yet been determined. Additional geotechnical investigation would be required in order to assess the risk of lateral spreading to occur on the project site. The potential impact associated with lateral spreading is considered a significant impact.

The project site is not located in an area of known ground subsidence or within any delineated zones of subsidence due to groundwater pumping or oil extraction. The potential for subsidence to occur on the project site is considered low. Therefore, the proposed project would result in a less than significant impact associated with ground subsidence.

As described above, given that the project site is underlain by sand and clay, there is a potential for liquefaction to occur on the project site. Additional geotechnical investigation would be required in order to assess the risk of liquefaction on the project site. The potential impact on liquefaction is considered a significant impact.

It is unknown whether collapsible soils are present on the project site. Additional geotechnical investigation would be required in order to assess the risk of collapsible soils to occur on the project site. The potential impact associated with collapsible soils is considered a significant impact.

Implementation of Mitigation Measure GEO-1, which requires the preparation of a design-level geotechnical report, would reduce the potential impacts associated with lateral spreading, liquefaction, and collapsible soils to a level less than significant.

Mitigation Measure(s)

No additional mitigation measures beyond Mitigation Measure GEO-1 are required.

Impact 3.7-7 Would the project be located on expansive soil, as defined in Table 18-1-B of the Uniform Building Code (1994), creating substantial direct or indirect risks to life or property?

As stated above, expansive soils are characterized by their ability to undergo significant volume changes (shrink or swell) due to variations in moisture content. Changes in soil moisture content can result from precipitation, landscape irrigation, utility leakage, roof drainage, perched groundwater, drought, or other factors and may result in unacceptable settlement or heave of structures. The project site is underlain by sand, gravelly sand and clay/silty clay. Generally, sands are not considered expansive soils. However, clays may exhibit moderate to high expansion potential due to variation in moisture content. Unless properly mitigated, shrink-swell soils could exert additional pressure on buried structures and electrical connections producing shrinkage cracks that could allow water infiltration and compromise the integrity of backfill material. These conditions could be worsened if structural facilities are constructed directly on expansive soil materials. This potential impact would be significant as structures could be damaged by these types of soils. In addition, the on-site soils, particularly clay /silty clay, are known to be corrosive. Corrosive soils can damage underground utilities including pipelines and cables, or weaken roadway structures. A site-specific geotechnical investigation would be required at the project site to determine the extent and effect of problematic soils. Implementation of Mitigation Measure GEO-1, which requires the preparation of a design-level

geotechnical report, would reduce potential impacts associated with expansive and corrosive soils to a level less than significant.

Mitigation Measure(s)

No additional mitigation measures beyond Mitigation Measure GEO-1 are required.

Impact 3.7-8 Would the project have soils incapable of adequately supporting the use of septic tanks or alternative wastewater disposal systems where sewers are not available for the disposal of wastewater?

The proposed project would not require an operations and maintenance building. The proposed solar facility would be remotely operated, controlled and monitored and with no requirement for daily on-site employees. Therefore, no septic or other wastewater disposal systems would be required for the project and no impact would occur.

Mitigation Measure(s)

No mitigation measures are required.

Impact 3.7-9 Would the project directly or indirectly destroy a unique paleontological resource or site or unique geologic feature?

As stated above, the project site is in the Salton Basin near the shoreline of ancient Lake Cahuilla. The lake covered much of the Imperial Valley and created an extensive lacustrine environment. Lake Cahuilla experienced several fill recession episodes before it finally dried up about 300 years ago. In 1905, the Colorado River overflowed into the Salton Basin creating the present-day Salton Sea. As previously mentioned above, the project site is generally underlain by deposits from periodic flooding of the Colorado River and Lake Cahuilla (Appendix G of this EIR). Sediments from this formation have yielded fossilized remains of continental vertebrates, invertebrates, and plants at numerous previously recorded fossil sites in the Imperial Valley. Therefore, the project site is considered paleontologically sensitive.

Although unlikely, project construction has the potential to unearth and/or potentially destroy previously undiscovered paleontological resources. This potential impact is considered a significant impact. However, implementation of Mitigation Measure GEO-2 would reduce the potential impact on paleontological resources to a level less than significant.

Mitigation Measure(s)

GEO-2 Paleontological Resources. In the event that unanticipated paleontological resources or unique geologic resources are encountered during ground-disturbing activities, work must cease within 50 feet of the discovery and a paleontologist shall be hired to assess the scientific significance of the find. The consulting paleontologist shall have knowledge of local paleontology and the minimum levels of experience and expertise as defined by the *Society of Vertebrate Paleontology's Standard Procedures (2010) for the Assessment and Mitigation of Adverse Impacts to Paleontological Resources*. If any paleontological resources or unique geologic features are found within the project site, the consulting paleontologist shall prepare a paleontological Treatment and Monitoring Plan to include the methods that will be used to protect paleontological resources that may exist within the project site, as well as procedures

for monitoring, fossil preparation and identification, curation of specimens into an accredited repository, and preparation of a report at the conclusion of the monitoring program.

Significance after Mitigation

Implementation of Mitigation Measure GEO-2 would reduce the potential impact on paleontological resources to a level less than significant. In the event that unanticipated paleontological resources or unique geologic resources are encountered during ground-disturbing activities, work must cease within 50 feet of the discovery and a paleontologist shall be hired to assess the scientific significance of the find.

3.7.4 Decommissioning/Restoration and Residual Impacts

Decommissioning/Restoration

Decommissioning and restoration of the project site at the end of its use as a solar facility would involve the removal of structures and restoration to prior (pre-solar project) conditions. No geologic or soil impacts associated with the restoration activities would be anticipated, and, therefore, no impact is identified.

No impact is anticipated from restoration activities as the ground disturbance and associated impacts on paleontological resources will have occurred during the construction phase of the project.

Residual

With implementation of Mitigation Measure GEO-1, impacts related to strong seismic ground shaking, liquefaction, lateral spreading, collapsible soils, expansive soils, and corrosive soils would be reduced to a level less than significant. With implementation of Mitigation Measure GEO-1 and Mitigation Measure HYD-1 in Section 3.10 Hydrology/Water Quality, potential impacts from erosion during construction activities would be reduced to a level less than significant. Implementation of Mitigation Measure GEO-2 would reduce the potential impact on paleontological resources to a level less than significant. The project would not result in residual significant and unmitigable impacts related to geology and soil resources.

3.8 Greenhouse Gas Emissions

This section includes an overview of existing greenhouse gas (GHG) emissions within the project area and identifies applicable federal, state, and local policies related to global climate change. The impact assessment provides an evaluation of potential adverse effects with regards to GHG emissions based on criteria derived from the CEQA Guidelines in conjunction with actions proposed in Chapter 2, Project Description. ECORP Consulting, Inc. prepared an *Air Quality and Greenhouse Gas Assessment* that assesses the climate change impacts of the VEGA SES 4 Solar Energy Project. This report is included in Appendix C of this EIR.

3.8.1 Existing Conditions

Greenhouse Gases

Climate change refers to long-term changes in temperature, precipitation, wind patterns, and other elements of the earth's climate system. An ever-increasing body of scientific research attributes these climatological changes to GHGs, particularly those generated from the production and use of fossil fuels.

GHGs refer to atmospheric gases that absorb solar radiation and subsequently emit radiation in the thermal infrared region of the energy spectrum, trapping heat in the Earth's atmosphere. These gases include carbon dioxide (CO₂), methane (CH₄), nitrous oxide (N₂O), and water vapor, among others. While climate change has been a concern for several decades, the establishment of the Intergovernmental Panel on Climate Change (IPCC) by the United Nations and World Meteorological Organization in 1988 has led to increased efforts devoted to GHG emissions reduction and climate change research and policy.

The dominant GHG emitted is CO₂, mostly from fossil fuel combustion. GHGs differ in how much heat each can trap in the atmosphere (i.e., global warming potential [GWP]). When accounting for GHGs, all types of GHG emissions are expressed in terms of carbon dioxide equivalent (CO₂e) and are typically quantified in metric tons (MT) or million metric tons. The GWP of a GHG is based on several factors, including the relative effectiveness of a gas to absorb infrared radiation and length of time that the gas remains in the atmosphere ("atmospheric lifetime"). The GWP of each gas is measured relative to CO₂, the most abundant GHG. The definition of GWP for a particular GHG is expressed relative to CO₂ over a specified time period. CH₄ traps over 25 times more heat per molecule than CO₂, and N₂O absorbs 298 times more heat per molecule than CO₂ (Appendix C of this EIR). State law defines GHGs as any of the following compounds CO₂, CH₄, N₂O, hydrofluorocarbons (HFC), perfluorocarbons (PFC) and sulfur hexafluoride (SF₆) (California HSC Section 38505(g)).

CO₂ is a colorless, odorless gas consisting of molecules made up of two oxygen atoms and one carbon atom. CO₂ is produced when an organic carbon compound, such as wood, or fossilized organic matter, such as coal, oil, or natural gas, is burned in the presence of oxygen. CO₂ is removed from the atmosphere by CO₂ "sinks", such as absorption by seawater and photosynthesis by ocean dwelling plankton and land plants, including forests and grasslands; however, seawater is also a source of CO₂ to the atmosphere, along with land plants, animals, and soils, when CO₂ is released during respiration. Whereas the natural production and absorption of CO₂ is achieved through the terrestrial biosphere and the ocean, humankind has altered the natural carbon cycle by burning coal, oil, natural gas, and wood.

CH₄ is a colorless, odorless non-toxic gas consisting of molecules made up of four hydrogen atoms and one carbon atom. CH₄ is combustible, and it is the main constituent of natural gas—a fossil fuel. CH₄ is released when organic matter decomposes in low oxygen environments. Natural sources include wetlands, swamps and marshes, termites, and oceans. Human sources include the mining of fossil fuels and transportation of natural gas, digestive processes in ruminant animals, such as cattle, rice paddies and the buried waste in landfills. Over the last 50 years, human activities, such as growing rice, raising cattle, using natural gas, and mining coal have added to the atmospheric concentration of CH₄. Other anthropogenic sources include fossil-fuel combustion and biomass burning.

N₂O is a colorless, non-flammable gas with a sweetish odor, commonly known as "laughing gas", and sometimes used as an anesthetic. N₂O is naturally produced in the oceans and in rainforests. Man-made sources of N₂O include the use of fertilizers in agriculture, nylon and nitric acid production, cars with catalytic converters and the burning of organic matter. Concentrations of N₂O also began to rise at the beginning of the industrial revolution.

Chlorofluorocarbons (CFC) are gases formed synthetically by replacing all hydrogen atoms in CH₄ or ethane with chlorine and/or fluorine atoms. CFCs are nontoxic, nonflammable, insoluble, and chemically un-reactive in the troposphere (the level of air at the Earth's surface). CFCs have no natural source but were first synthesized in 1928. It was used for refrigerants, aerosol propellants, and cleaning solvents. Because of the discovery that they are able to destroy stratospheric ozone (O₃), an ongoing global effort to halt their production was undertaken and has been extremely successful, so much so that levels of the major CFCs are now remaining steady or declining; however, their long atmospheric lifetimes mean that some of the CFCs will remain in the atmosphere for over 100 years.

HFCs are synthesized chemicals that are used as a substitute for CFCs. Out of all of the GHGs; HFCs are one of three groups with the highest GWP. HFCs are synthesized for applications, such as automobile air conditioners and refrigerants.

PFCs have stable molecular structures and do not break down through the chemical processes in the lower atmosphere. High-energy ultraviolet rays about 60 kilometers above Earth's surface are able to destroy the compounds. Because of this, PFCs have very long lifetimes, between 10,000 and 50,000 years. The two main sources of PFCs are primary aluminum production and semiconductor manufacture.

SF₆ is an extremely potent GHG. SF₆ is very persistent, with an atmospheric lifetime of more than 1,000 years. Thus, a relatively small amount of SF₆ can have a significant long-term impact on global climate change. SF₆ is human-made, and the primary user of SF₆ is the electric power industry. Because of its inertness and dielectric properties, it is the industry's preferred gas for electrical insulation, current interruption, and arc quenching (to prevent fires) in the transmission and distribution of electricity. SF₆ is used extensively in high voltage circuit breakers and switchgear, and in the magnesium metal casting industry.

Statewide Greenhouse Gas Emissions Inventory

In 2020, CARB released the 2020 edition of the California GHG inventory covering calendar year 2018 emissions. In 2018, California emitted 425.3 million gross metric tons of CO_{2e} including from imported electricity. The current inventory covers the years 2000 to 2018 and is summarized in Table 3.8-1. Data sources used to calculate this GHG inventory include California and Federal agencies, international organizations, and industry associations. The calculation methodologies are consistent with guidance from the IPCC. The 2000 emissions level is the sum total of sources from all sectors and categories in the inventory. The inventory is divided into seven broad sectors and categories in

the inventory. These sectors include agriculture, commercial and residential, electric power, industrial, transportation, recycling and waste, and high GWP gases.

As shown in Table 3.8-1, combustion of fossil fuel in the transportation sector was the single largest source of California’s GHG emissions in 2018, accounting for approximately 30 percent of total GHG emissions in the state.

Table 3.8-1. California Greenhouse Gas Emissions Inventory 2000 to 2018

Sector	Total 2000 Emissions (MMTCO _{2e})	Total 2018 Emissions (MMTCO _{2e})
Agriculture	30.97	32.57
Commercial and Residential	43.95	41.37
Electric Power	104.75	63.11
Industrial	96.18	89.18
Transportation	178.40	169.50
Recycling and Waste	7.67	9.09
High GWP Gases	6.28	20.46

Source: CARB 2020

Notes:

GWP=global warming potential; MMTCO_{2e}=million metric tons of CO₂ equivalent

Potential Effects of Climate Change

Globally, climate change has the potential to affect numerous environmental resources through uncertain impacts related to future air temperatures and precipitation patterns. Although climate change is driven by global atmospheric conditions, climate change impacts are felt locally. A scientific consensus confirms that climate change is already affecting California.

The California Natural Resources Agency’s Fourth Climate Change Assessment (Fourth Assessment) produced updated climate projections that provide state-of-the-art understanding of different possible climate futures for California. The science is highly certain that California (and the world) will continue to warm and experience greater impacts from climate change in the future. While the IPCC and the National Climate Assessment have released descriptions of scientific consensus on climate change for the world and the U.S., respectively, the Fourth Assessment summarizes the current understanding of climate impacts and adaptation options in California (California Natural Resources Agency 2018). Projected changes in California include:

- **Temperatures:** If GHG emissions continue at current rates then California will experience average daily high temperatures that are warmer than the historical average by:
 - 2.7 Fahrenheit (°F) from 2006 to 2039
 - 5.8°F from 2040 to 2069
 - 8.8°F from 2070 to 2100

- **Wildfire:** One Fourth Assessment model suggests large wildfires (greater than 25,000 acres) could become 50 percent more frequent by the end of century if emissions are not reduced. The model produces more years with extremely high areas burned, even compared to the historically destructive wildfires of 2017 and 2018. By the end of the century, California could experience wildfires that burn up to a maximum of 178 percent more acres per year than current averages.
- **Sea-Level Rise:** If emissions continue at current rates, the Fourth Assessment model results indicate that total sea-level rise by 2100 is expected to be 54 inches, almost twice the rise that would occur if GHG emissions are lowered to reduce risk.
- **Snowpack:** By 2050, the average water supply from snowpack is projected to decline to 2/3 from historical levels. If emissions reductions do not occur, water from snowpack could fall to less than 1/3 of historical levels by 2100.
- **Agriculture:** Agricultural production could face climate-related water shortages of up to 16 percent in certain regions. Regardless of whether California receives more or less annual precipitation in the future, the state will be dryer because hotter conditions will increase the loss of soil moisture (California Natural Resources Agency 2018).

3.8.2 Regulatory Setting

This section identifies and summarizes federal, state, and local laws, policies, and regulations that are applicable to the project.

Federal

At the federal level, there is currently no overarching law related to climate change or the reduction of GHGs. The U.S. EPA is developing regulations under the CAA to be adopted in the near future, pursuant to the U.S. EPA's authority under the CAA. Foremost amongst recent developments have been the settlement agreements between the U.S. EPA, several states, and nongovernmental organizations (NGO) to address GHG emissions from electric generating units and refineries; the U.S. Supreme Court's decision in *Massachusetts v. EPA*; and U.S. EPA's "Endangerment Finding," "Cause or Contribute Finding," and "Mandatory Reporting Rule." On September 20, 2013, the U.S. EPA issued a proposal to limit carbon pollution from new power plants. The U.S. EPA is proposing to set separate standards for natural gas-fired turbines and coal-fired units.

Although periodically debated in Congress, no federal legislation concerning GHG limitations has yet been adopted. In *Coalition for Responsible Regulation, Inc., et al. v. EPA*, the United States Court of Appeals upheld the U.S. EPA's authority to regulate GHG emissions under CAA. Furthermore, under the authority of the CAA, the EPA is beginning to regulate GHG emissions starting with large stationary sources. In 2010, the U.S. EPA set GHG thresholds to define when permits under the New Source Review Prevention of Significant Deterioration (PSD) standard and Title V Operating Permit programs are required for new and existing industrial facilities. In 2012, U.S. EPA proposed a carbon pollution standard for new power plants.

Corporate Average Fuel Standards

Established by the U.S. Congress in 1975, the Corporate Average Fuel Economy (CAFE) standards reduce energy consumption by increasing the fuel economy of cars and light trucks. The National Highway Traffic Safety Administration (NHTSA) and U.S. EPA jointly administer the CAFE standards.

The U.S. Congress has specified that CAFE standards must be set at the “maximum feasible level” with consideration given for: (1) technological feasibility; (2) economic practicality; (3) effect of other standards on fuel economy; and (4) need for the nation to conserve energy.

Fuel efficiency standards for medium- and heavy-duty trucks have been jointly developed by U.S. EPA and NHTSA. The Phase 1 heavy-duty truck standards apply to combination tractors, heavy-duty pickup trucks and vans, and vocational vehicles for model years 2014 through 2018, and result in a reduction in fuel consumption from 6 to 23 percent over the 2010 baseline, depending on the vehicle type (U.S. EPA 2011). In 2012, the U.S. EPA and NHTSA also adopted the Phase 2 heavy-duty truck standards, which cover model years 2021 through 2027 and require the phase-in of a 5 to 25 percent reduction in fuel consumption over the 2017 baseline depending on the compliance year and vehicle type (U.S. EPA 2016).

State

Executive Order S-3-05 – Statewide Greenhouse Gas Emissions Targets

On June 1, 2005, the Governor issued EO S-3-05 which set the following GHG mission reduction targets:

- By 2020, reduce GHG emissions to 1990 levels
- By 2050, reduce GHG emissions to 80 percent below 1990 levels

This EO directed the secretary of the California EPA to oversee the efforts made to reach these targets, and to prepare biannual biennial reports on the progress made toward meeting the targets and on the impacts on California related to global warming. The first such Climate Action Team Assessment Report was produced in March 2006 and has been updated every two years thereafter. This goal was further reinforced with the passage of AB 32 in 2006 and SB 32 in 2016.

Executive Order S-01-07

This order, signed by Governor Schwarzenegger, sets forth the low carbon fuel standard (LCFS) for California. Under this EO, the carbon intensity of California’s transportation fuels is to be reduced by at least 10 percent by the year 2020. CARB re-adopted the LCFS regulation in September 2015, and the changes went into effect on January 1, 2016. The program establishes a strong framework to promote the low-carbon fuel adoption necessary to achieve the Governor’s 2030 and 2050 GHG reduction goals.

Assembly Bill 32 – California Global Warming Solutions Act

In 2006, the California legislature passed Assembly Bill (AB) 32 (Health and Safety Code § 38500 et seq., or AB 32), also known as the Global Warming Solutions Act. AB 32 requires CARB to design and implement feasible and cost-effective emission limits, regulations, and other measures, such that statewide GHG emissions are reduced to 1990 levels by 2020 (representing a 25 percent reduction in emissions). Pursuant to AB 32, CARB adopted a Scoping Plan in December 2008, which outlines measures to meet the 2020 GHG reduction goals. California is on track to meet or exceed the target of reducing GHG emissions to 1990 levels by the end of 2020.

The Scoping Plan is required by AB 32 to be updated at least every five years. The latest update, the 2017 Scoping Plan Update, addresses the 2030 target established by Senate Bill (SB) 32 as discussed below and establishes a proposed framework of action for California to meet a 40 percent reduction

in GHG emissions by 2030 compared to 1990 levels. The key programs that the Scoping Plan Update builds on include increasing the use of renewable energy in the state, the Cap-and-Trade Regulation, the Low Carbon Fuel Standard, and reduction of methane emissions from agricultural and other wastes.

Senate Bill 32 and Assembly Bill 197 of 2016

In August 2016, Governor Brown signed SB 32 and AB 197, which serve to extend California's GHG reduction programs beyond 2020. SB 32 amended the Health and Safety Code to include § 38566, which contains language to authorize CARB to achieve a statewide GHG emission reduction of at least 40 percent below 1990 levels by no later than December 31, 2030. SB 32 codified the targets established by Executive Order (EO) B-30-15 for 2030, which set the next interim step in the State's continuing efforts to pursue the long-term target expressed in EOs S-3-05 and B-30-15 of 80 percent below 1990 emissions levels by 2050.

Renewable Portfolio Standard

The RPS promotes diversification of the state's electricity supply and decreased reliance on fossil fuel energy sources. Originally adopted in 2002 with a goal to achieve a 20 percent renewable energy mix by 2020 (referred to as the "initial RPS"), the goals have been accelerated and increased by EOs S-14-08, S-21-09, SB 350, and SB 100.

The RPS is included in CARB's Scoping Plan list of GHG reduction measures to reduce energy sector emissions. It is designed to accelerate the transformation of the electricity sector through such means as investment in the energy transmission infrastructure and systems to allow integration of large quantities of intermittent wind and solar generation. Increased use of renewables would decrease California's reliance on fossil fuels, thus reducing emissions of GHGs from the electricity sector.

Senate Bill 350

The RPS program was further accelerated in 2015 with SB 350 which mandated a 50 percent RPS by 2030. SB 350 includes interim annual RPS targets with three-year compliance periods and requires 65 percent of RPS procurement to be derived from long-term contracts of 10 or more years.

Senate Bill 100

On September 10, 2018, Governor Brown signed SB 100, establishing that 100 percent of all electricity in California must be obtained from renewable and zero-carbon energy resources by December 31, 2045. SB 100 also creates new standards for the RPS goals established by SB 350 in 2015. Specifically, the bill increases required energy from renewable sources for both investor-owned utilities and publicly-owned utilities from 50 percent to 60 percent by 2030. Incrementally, these energy providers must also have a renewable energy supply of 33 percent by 2020, 44 percent by 2024, and 52 percent by 2027. California must procure 100 percent of its energy from carbon free energy sources by the end of 2045.

Climate Change Scoping Plan

The Scoping Plan released by CARB in 2008 outlined the state's strategy to achieve the AB 32 goals. This Scoping Plan, developed by CARB in coordination with the Climate Action Team, proposed a comprehensive set of actions designed to reduce overall GHG emissions in California, improve the environment, reduce dependence on oil, diversify our energy sources, save energy, create new jobs,

and enhance public health. It was adopted by CARB at its meeting in December 2008. According to the Scoping Plan, the 2020 target of 427 million MTCO_{2e} requires the reduction of 169 million MTCO_{2e}, or approximately 28.3 percent, from the state's projected 2020 BAU emissions level of 596 million MTCO_{2e}.

However, in August 2011, the Scoping Plan was re-approved by the Board and includes the Final Supplement to the Scoping Plan Functional Equivalent Document. This document includes expanded analysis of project alternatives as well as updates the 2020 emission projections in light of the current economic forecasts. Considering the updated 2020 BAU estimate of 507 million MTCO_{2e}, only a 16 percent reduction below the estimated new BAU levels would be necessary to return to 1990 levels by 2020. The 2011 Scoping Plan expands the list of nine Early Action Measures into a list of 39 Recommended Actions.

In May 2014, CARB developed; in collaboration with the Climate Action Team, the *First Update to California's Climate Change Scoping Plan (Update)*, which shows that California is on track to meet the near-term 2020 GHG limit and is well positioned to maintain and continue reductions beyond 2020 as required by AB 32. In accordance with the United Nations Framework Convention on Climate Change (UNFCCC), CARB is beginning to transition to the use of the AR4's 100-year GWPs in its climate change programs. CARB has recalculated the 1990 GHG emissions level with the AR4 GWPs to be 431 million MTCO_{2e}; therefore, the 2020 GHG emissions limit established in response to AB 32 is now slightly higher than the 427 million MTCO_{2e} in the initial Scoping Plan.

CARB adopted the latest update to the Climate Change Scoping Plan in December 2017. The 2017 Scoping Plan is guided by the EO B-30-15 GHG reduction target of 40 percent below 1990 levels by 2030. The 2017 Scoping Plan builds upon the framework established by the initial Scoping Plan and the First Update, while identifying new, technologically feasible, and cost-effective strategies to ensure that California meets its GHG reduction targets in a way that promotes and rewards innovation, continues to foster economic growth, and delivers improvements to the environment and public health, including in disadvantaged communities. The Plan includes policies to require direct GHG reductions at some of the State's largest stationary sources and mobile sources. These policies include the use of lower GHG fuels, efficiency regulations, and the Cap-and-Trade Program, which constrains and reduces emissions at covered sources (CARB 2017).

The majority of the Scoping Plan's GHG reduction strategies are directed at the two sectors with the largest GHG emissions contributions: transportation and electricity generation. The GHG reduction strategies for these sectors involve statutory mandates affecting vehicle or fuel manufacture, public transit, and public utilities. The reduction strategies employed by CARB are designed to reduce emissions from existing sources as well as future sources.

Senate Bill 97

SB 97, enacted in 2007, amends the CEQA statute to clearly establish that GHG emissions and the effects of GHG emissions are appropriate subjects for CEQA analysis. It directs Office of Planning and Research (OPR) to develop draft CEQA Guidelines "for the mitigation of GHG emissions or the effects of GHG emissions" by July 1, 2009, and directs the Resources Agency to certify and adopt the CEQA Guidelines by January 1, 2010.

On December 30, 2009, the Natural Resources Agency adopted amendments to the CEQA Guidelines in the CCR. The amendments went into effect on March 18, 2010, and are summarized below:

- Climate action plans and other GHG reduction plans can be used to determine whether a project has significant impacts, based upon its compliance with the plan.

- Local governments are encouraged to quantify the GHG emissions of proposed projects, noting that they have the freedom to select the models and methodologies that best meet their needs and circumstances. In addition, consideration of several qualitative factors may be used in the determination of significance, such as the extent to which the given project complies with state, regional, or local GHG reduction plans and policies. The Guidelines do not set or dictate specific thresholds of significance.
- When creating their own thresholds of significance, local governments may consider the thresholds of significance adopted or recommended by other public agencies, or recommended by experts.
- New amendments include guidelines for determining methods to mitigate the effects of GHG emissions in Appendix G of the CEQA Guidelines.
- The Guidelines are clear to state that “to qualify as mitigation, specific measures from an existing plan must be identified and incorporated into the project; general compliance with a plan, by itself, is not mitigation.”
- The Guidelines promote the advantages of analyzing GHG impacts on an institutional, programmatic level, and, therefore, approve tiering of environmental analyses and highlights some benefits of such an approach.
- EIRs must specifically consider a project's energy use and energy efficiency potential, pursuant to Appendix F of the CEQA Guidelines.

Senate Bill 375 – Regional Emissions Targets

SB 375 requires that regions within the state which have a metropolitan planning organization (MPO) must adopt a sustainable communities' strategy as part of their RTPs. The strategy must be designed to achieve certain goals for the reduction of GHG emissions. The bill finds that “it will be necessary to achieve significant additional GHG reductions from changed land use patterns and improved transportation. Without improved land use and transportation policy, California will not be able to achieve the goals of AB 32.” SB 375 provides that new CEQA provisions be enacted to encourage developers to submit applications and local governments to make land use decisions that will help the state achieve its goals under AB 32,” and that “current planning models and analytical techniques used for making transportation infrastructure decisions and for air quality planning should be able to assess the effects of policy choices, such as residential development patterns, expanded transit service and accessibility, the walkability of communities, and the use of economic incentives and disincentives.”

Regional

Southern California Association of Governments - 2020-2045 Regional Transportation Plan/Sustainable Communities Strategy

The SCAG is the designated MPO for Los Angeles, Ventura, Orange, San Bernardino, Riverside, and Imperial Counties. CEQA requires that regional agencies like SCAG review projects and plans throughout its jurisdiction. SCAG, as the region’s “Clearinghouse,” collects information on projects of varying size and scope to provide a central point to monitor regional activity. SCAG has the responsibility of reviewing dozens of projects, plans, and programs every month. Projects and plans that are regionally significant must demonstrate to SCAG their consistency with a range of adopted regional plans and policies.

In September 2020, SCAG adopted the 2020-2045 RTP/SCS. The RTP/SCS includes a strong commitment to reduce emissions from transportation sources to comply with SB 375, improve public health, and meet the NAAQS as set forth by the federal CAA (see Section 3.4, Air Quality, of this EIR). The following SCAG goal is applicable to the project:

- Reduce greenhouse gas emissions and improve air quality

As a solar generation facility, the proposed project would improve air quality by reducing the use of fossil fuels in energy production.

Local

County of Imperial

Pursuant to the requirements of SB 97, the Resources Agency adopted amendments to the CEQA Guidelines to provide regulatory guidance on the analysis and mitigation of GHG emissions in CEQA documents, while giving lead agencies the discretion to set quantitative or qualitative thresholds for the assessment and mitigation of GHG and climate change impacts. Formal CEQA thresholds for lead agencies must always be established through a public hearing process. Imperial County has not established formal quantitative or qualitative thresholds through a public rulemaking process, but CEQA permits the lead agency to establish a project-specific threshold of significance if backed by substantial evidence, until such time as a formal threshold is approved.

3.8.3 Impacts and Mitigation Measures

Thresholds of Significance

Based on CEQA Guidelines Appendix G, project impacts related to GHG emissions are considered significant if any of the following occur:

- Generate GHG emissions, either directly or indirectly, that may have a significant impact on the environment
- Conflict with an applicable plan, policy, or regulation adopted for the purpose of reducing the emissions of GHGs

As discussed in Section 15064.4 of the CEQA Guidelines, the determination of the significance of GHG emissions calls for a careful judgment by the lead agency consistent with the provisions in Section 15064. A lead agency should make a good-faith effort, based to the extent possible on scientific and factual data, to describe, calculate or estimate the amount of GHG emissions resulting from a project. A lead agency shall have discretion to determine, in the context of a particular project, whether to:

1. Quantify greenhouse gas emissions resulting from a project; and/or
2. Rely on a qualitative analysis or performance-based standards.

A lead agency should consider the following factors, among others, when assessing the significance of impacts from GHG emissions on the environment:

1. The extent to which the project may increase or reduce GHG emissions as compared to the existing environmental setting;

2. Whether the project emissions exceed a threshold of significance that the lead agency determines applies to the project; and
3. The extent to which the project complies with regulations or requirements adopted to implement a statewide, regional, or local plan for the reduction or mitigation of GHG emissions. Such requirements must be adopted by the relevant public agency through a public review process and must reduce or mitigate the project's incremental contribution of GHG emissions. If there is substantial evidence that the possible effects of a particular project are still cumulatively considerable notwithstanding compliance with the adopted regulations or requirements, an EIR must be prepared for the project. In determining the significance of impacts, the lead agency may consider a project's consistency with the State's long-term climate goals or strategies, provided that substantial evidence supports the agency's analysis of how those goals or strategies address the project's incremental contribution to climate change and its conclusion that the project's incremental contribution is not cumulatively considerable.

Mojave Desert Air Quality Management District's Interim Thresholds

The ICAPCD has not adopted a GHG significance threshold. As previously described, Section 15064.7(c) of the CEQA Guidelines specifies that “[w]hen adopting or using thresholds of significance, a lead agency may consider thresholds of significance previously adopted or recommended by other public agencies, or recommended by experts, provided the decision of the lead agency to adopt such thresholds is supported by substantial evidence” (14 CCR 15064.7(c)). Thus, in the absence of any GHG emissions significance thresholds, the projected emissions are compared to the Mojave Desert Air Quality Management District (MDAQMD) numeric threshold of 100,000 metric tons of CO₂e annually.

While significance thresholds used in the Mojave Desert Air Basin are not binding on the ICAPCD or County of Imperial, they are instructive as a comparative metric of the project's potential GHG impact. This threshold is also appropriate as the MDAQMD GHG thresholds were formulated based on similar geography and climate patterns as found in Imperial County. Therefore, the 100,000-metric ton of CO₂e threshold is appropriate for this analysis.

Methodology

The project-related direct and indirect emissions of GHGs were estimated using the similar methods for quantification of criteria air pollutants, as described in Section 3.4 Air Quality. Where GHG emission quantification was required, emissions were modeled using CalEEMod, version 2020.4.0. CalEEMod is a statewide land use emissions computer model designed to quantify potential GHG emissions associated with both construction and operations from a variety of land use projects. Project construction-generated GHG emissions were calculated using CalEEMod model defaults for Imperial County coupled with information provided by the project applicant. For instance, construction activities would primarily involve demolition and grubbing, grading of the project site to establish access roads and pads for electrical equipment, trenching for underground electrical collection lines, and the installation of solar equipment and security fencing. Construction is estimated to take 12-18 months and would begin in late 2022 or 2023. The number of on-site construction workers for the solar facility is not expected to exceed 150 workers at any time. The number of on-site construction workers for the BESS and substation is not expected to exceed 100 workers at any one time. According to the Traffic Impact Study prepared for the project (Appendix K of this EIR), project construction would generate a maximum of 500 construction worker-commute trips in a single day.



Operational GHG emissions account for the maximum three workers visiting the site in a single day. Such visits include inspections, equipment servicing, site and landscape clearing, and periodic washing of the PV modules if needed (up to two times per year) to maintain power generation efficiency. Therefore, operational onsite equipment use is accounted in addition to the consumption of 10 acre-feet (3,259,000 gallons) of water annually.

Impact Analysis

Impact 3.8-1 Would the project generate GHG emissions, either directly or indirectly, that may have a significant impact on the environment?

Construction and operation of the project would result in a relatively small amount of GHG emissions. The project would generate GHG emissions during construction and routine operational activities at the project site.

Construction. Construction-related activities that would generate GHG emissions include worker commute trips, haul trucks carrying supplies and materials to and from the project site, and off-road construction equipment (e.g., dozers, loaders, excavators). Table 3.8-2 shows the specific construction generated GHG emissions that would result from construction of the project. Once construction is complete, the generation of these GHG emissions would cease.

Table 3.8-2. Project Construction-Related Greenhouse Gas Emissions

Emissions Source	CO ₂ e (metric tons/year)
Construction Year One	913
Construction Year Two	611
MDAQMD Significance Threshold	100,000
Exceed MDAQMD's Significance Threshold?	No

Source: Appendix C of this EIR

As shown in Table 3.8-2, the project would result in the generation of approximately 913 metric tons of CO₂e in the first calendar year of construction and 611 metric tons in the second calendar year of construction. Therefore, the construction emissions are less than the MDAQMD's screening threshold of 100,000 MTCO₂e per year. As previously described, this significance threshold is not binding on the project, yet in the absence of an established threshold from the ICAPCD or County it is instructive for comparison purposes. This threshold is also appropriate for use in this analysis as the MDAQMD GHG thresholds were formulated based on similar geography and climate patterns as found in Imperial County.

Operation. Once the project is constructed and operational, the proposed project would have no major stationary emission sources and would require minimal vehicular trips. Therefore, operation of the proposed solar facility would result in substantially lower emissions than project construction. Long-term GHG emissions attributed to operations of the project are identified in Table 3.8-3. As shown in Table 3.8-3, operational-generated emissions would generate approximately 1,194 metric tons of CO₂e annually. Therefore, the proposed project's operational emissions are less than the MDAQMD's screening threshold of 100,000 MTCO₂e per year. As shown in Table 3.8-3, the majority of emissions are attributable to indirect energy consumption. The BESS component of the project was modeled to account for HVAC use. However, this is potentially a conservative estimate since the energy source

for the BESS HVAC could include the solar energy generated by the project itself, which would be an emissions-free source of energy. Impacts would be less than significant.

Table 3.8-3. Project Operation-Related Greenhouse Gas Emissions

Emissions Source	CO ₂ e (metric tons/year)
Area Source	0
Energy	1,088
Mobile	7
Off-Road Equipment	8
Waste	82
Water	8
Total	1,194
MDAQMD Significance Threshold	100,000
Exceed MDAQMD's Significance Threshold?	No

Source: Appendix C of this EIR

Additionally, the project proposes a solar energy generation facility intended to generate renewable energy. Solar plants generate far less GHG life-cycle emissions (approximately 83 to 94 percent less) than fossil-fueled energy plants. The proposed project would contribute to the continued reduction of GHG emissions in the interconnected California and western U.S. electricity systems, as the energy produced by the project would displace GHG emissions that would otherwise be produced by existing business-as-usual power generation resources (including natural gas, coal, arid renewable combustion resources). The project would generate a maximum of four MW of electricity at any one time. Table 3.8-4 shows the emissions that would potentially be displaced by the proposed project. As shown in Table 3.8-4, the proposed project would potentially displace approximately 53,210 MTCO₂e per year, and approximately 1,596,596 MTCO₂e over the course of 30 years. The proposed project's annual indirect GHG emissions from the displacement of fossil fuel fired electricity generation is significantly higher than the project's annualized direct and indirect emissions sources. Implementation of the proposed project would result in a less than significant impact associated with the generation of GHG emissions.



Table 3.8-4. Proposed Project Displaced GHG Emissions (Metric Tons)

	Emissions (Metric Tons)			
	CO ₂	CH ₄	N ₂ O	CO _{2e}
Emissions Displaced Annually (metric tons)				
Displaced Natural-Gas Source Emissions	47,585	0.00	0.00	47,585
Displaced Coal-Source Emissions	5,626	0.037	0.028	5,635
Total	53,210	0.037	0.028	53,220
Emissions Displaced over 30 Years (metric tons)				
Total	1,596,309	1.118	0.838	1,596,596

Source: Appendix C of this EIR

Notes: In order to provide a conservative analysis, the proposed project is assumed to generate electricity 25 percent of the time available (2,190 hours annually). Heat Rate indicates the energy generator efficiency of existing fossil-fuel based energy generators. The heat rate of a power plant measures the amount of fuel used to generate one unit of electricity. Power plants with lower heat rates are more efficient than plants with higher heat rates. The CEC's "Updated Thermal Power Plant Efficiency Measures and Operational Characteristics for Production Cost Modeling" (2019) estimates heat rates and operating ranges for thermal power plants supplying energy to California. The average heat rate of power plants types are as follows: **Steam Boiler fueled by coal: 10,800 heat rate **Steam Boiler fueled by natural gas: 10,200 heat rate **Gas Turbine: 10,100 heat rate **Combined natural gas Boiler and Turbine: 7,640 heat rate. By omitting steam boilers fueled by coal since so little of California's energy is derived from coal, the average heat rate = 9,313 [(10,100 + 10,200 + 7,640) ÷ 3 = 9,313]. 100 MW (219,000,000 annual kWh) × 9,313 heat rate = 2,039,547,000,000 Btu displaced from fossil fuel production. Fossil fuel-based energy consumption in California is predominately derived from natural gas (37.06 percent). Coal constitutes 2.74 percent of all fossil fuel-based energy. Therefore, 865,175,837,400 of the displaced Btu is displaced natural gas and unspecified nonrenewable sources consumption and 55,883,587,800 of the displaced Btu is displaced coal. The heat content of coal is assumed at 24 million Btu per ton of coal burned. At a rate of 24 million Btu per ton of coal burned, the project would displace 2,328 tons of burned coal annually.

Mitigation Measure(s)

No mitigation measures are required.

Impact 3.8-2 Would the project conflict with an applicable plan, policy, or regulation adopted for the purpose of reducing the emissions of GHGs?

As discussed in Impact 3.8-1, the proposed project would generate a relatively small amount of GHG emissions. The proposed project-generated GHG emissions would not exceed the MDAQMD significance thresholds, which were prepared with the purpose of complying with statewide GHG-reduction efforts. While the project would emit some GHG emissions during construction and a very small amount during operations, the contribution of renewable resource energy production to meet the goals of the Renewable Portfolio Standard (Scoping Plan Measure E-3) would result in a net cumulative reduction of GHG emissions, a key environmental benefit. Scoping Plan Measure E-3, Renewable Portfolio Standard, of the Climate Change Scoping Plan requires that all investor-owned utility companies generate 60 percent of their energy demand from renewable sources by the year 2030. Therefore, the short-term minor generation of GHG emissions during construction, which is necessary to create this new, low-GHG emitting power-generating facility, as well as the negligible amount generated during ongoing maintenance operations, would be more than offset by GHG emission reductions associated with solar-generated energy during operation.

Increasing sources of solar energy is one of the measures identified under the Scoping Plan to reduce statewide GHG emissions. The proposed project would reduce GHG emissions in a manner consistent with SB 32 and other California GHG-reducing legislation by creating a new source of solar power to replace the current use of fossil-fuel power and reduce GHG emissions power generation and use.

Implementation of the proposed project would result in a less than significant impact associated with the potential to conflict with an applicable plan, policy, or regulation adopted for the purpose of reducing the emission of GHG.

Mitigation Measure(s)

No mitigation measures are required.

3.8.4 Decommissioning/Restoration and Residual Impacts

Decommissioning/Restoration

Similar to construction activities, decommissioning and restoration would result in GHG emissions below allowable thresholds. Construction activities during decommissioning and restoration would adhere to Mitigation Measures AQ-1 and AQ-2 outlined in Section 3.4, Air Quality of this EIR, further reducing GHG emissions. Therefore, the impact is considered less than significant.

Residual

The proposed project's GHG emissions would result in a less than significant impact. Project operation, subject to the provision of a CUP, would generally be consistent with statewide GHG emission goals and policies including SB 32. Project consistency with applicable plans, policies, and regulations adopted to reduce GHG emissions would ensure that the project would not result in any residual significant and unavoidable impacts with regards to global climate change.

3.9 Hazards and Hazardous Materials

Information contained in this section is summarized from the Phase I Environmental Site Assessment (ESA) prepared for the project by GS Lyon Consultants, Inc. The Phase I ESA prepared for the project site was used to assess the potential hazards and hazardous materials found on-site or adjacent to the project site. This report is included in Appendix H of this EIR. This section addresses potential hazards and hazardous materials for construction and operational impacts.

3.9.1 Existing Conditions

The project site is located on approximately 450 acres of privately-owned agriculturally-zoned land within unincorporated Imperial County that is not currently under cultivation. The boundaries of the project site include the All-American Canal forming the northern boundary, the U.S./Mexico international border forming the southern boundary, and undeveloped desert land forming the eastern boundary. The project site is currently characterized by flat and undeveloped land, portions of which have been disturbed associated with previous agricultural-related activities.

A farmyard is located in the north-central portion of the project site. A small masonry building housing water pumps, an above ground fuel storage tank (AST) and a storage building, all located within a chain-link fenced area comprise the farmyard. A small equipment storage area with a disc, a trap wagon, and other miscellaneous farm equipment is also located northeast of the farmyard area. Two central-pivot sprinklers are located in the central portion of the project site.

Records Review

A review of historic aerial photographs, historic topographic maps, historic Sanborn Fire Insurance maps, governmental regulatory databases, and other regulatory and agency databases was performed to evaluate potential adverse environmental conditions resulting from previous ownership and uses of the project site.

GS Lyon Consultants, Inc. contracted Environmental Data Resources, Inc. of Shelton, Connecticut which queries and maintains comprehensive environmental databases and historical information, including proprietary databases, aerial photography, topographic maps, Sanborn Maps, and city directories to generate a compilation of federal, state and tribal regulatory lists containing information regarding hazardous materials occurrences on or within the prescribed radii of American Society of Testing and Materials Practice E 1527-13. The search of each database was conducted using the approximate minimum search distances from the subject property defined by the Standard. The purpose of the records review is to obtain and review reasonably ascertainable records that would help identify recognized environmental conditions or historical recognized environmental conditions in connection with the project site. The project site is not identified in the Environmental Data Resources, Inc. report as being located on a hazardous materials site pursuant to Government Code Section 65962.5. The results of the background review are presented in the Phase I ESA (Appendix H of this EIR).

Historical aerial photographs from EDR dating back to 1937 and Google Earth aerial photographs from 1996 were reviewed. In 1937, the western portion of the subject site appears to have been fallow agricultural field while the eastern portion was vacant desert land and newly constructed All-American Canal is to the north of the project site. In 1953, the canals that crossed the All-American Canal had been removed leaving a heavily brushed area in the western portion of the project site.

The 1985 aerial photograph shows a circular agricultural area occupying the eastern portion of the project site. The 1996 to 2010 aerial photographs are similar to the 1985 aerial photograph; however, several small structures are noted in the area of the farmyard in the northcentral portion of the project site. The 2018 aerial photograph shows the subject site as being similar to the present time with the agricultural fields have been fallowed.

Site Reconnaissance

A site reconnaissance was performed on September 22, 2020. The site visit consisted of a driving the perimeter of the project site and randomly crossing the project site. The reconnaissance included visual observations of surficial conditions at the project site and observation of adjoining properties to the extent that they were visible from public areas. The site visit evaluated the project site and adjoining properties for potential hazardous materials/waste and petroleum product use, storage, disposal, or accidental release, including the following: presence of tank and drum storage; mechanical or electrical equipment likely to contain liquids; evidence of soil or pavement staining or stressed vegetation; ponds, pits, lagoons, or sumps; suspicious odors; fill and depressions; or any other condition indicative of potential contamination.

Underground and Aboveground Storage Tanks, Drums, or Containers

No underground storage tanks (USTs) were observed within the project site during the site reconnaissance. One AST was observed within the fenced farmyard; however access to the tank was not available at the time to determine fuel containment. Several steel 55-gallon drums were observed on the project site and no fluids were observed in the drums that were accessible. No other drums or storage containers, nor any open or damaged containers containing unidentified substances were observed at the project site. Additionally, no reports of spills or leaks were identified in the EDR report.

Surface Staining

No evidence of stained soil or pavement was observed on the project site.

Sewer/Water

No evidence of septic systems or wells was observed on the project site.

Suspect Polychlorinated Biphenyl (PCB) Containing Equipment

Pole-mounted sealed electrical transformers owned and maintained by the IID are located on the embankment of the All-American Canal adjacent to the farmyard of the project site. However, the IID has replaced all transformers that contained PCBs within recent years. Stickers were observed on the transformers that indicated that they had been tested for PCBs. No leaks were observed during the site reconnaissance.

Pesticides

Based on the review of environmental records, historical documents, and site conditions, the project site has been in agricultural use and/or vacant since the 1930s. Residues of currently available pesticides and currently banned pesticides, such as Dichlorodiphenyltrichloroethane/ Dichlorodiphenyldichloroethylene (DDT/DDE) may be present in near surface soils in limited concentrations.

Therefore, there is a potential for the project site to contain hazards related to pesticide and herbicide use from aerial and/or ground application which can migrate via surface run-off. The concentrations of these pesticides found on other Imperial Valley agricultural sites are typically less than 25 percent of the current regulatory threshold limits and are not considered a significant environmental hazard. The presence and concentration of near surface pesticides at the project site can be accurately characterized only by site-specific sampling and testing.

Lead and Asbestos

The potential for asbestos containing materials (ACM) and lead based paint residues existing at the project site is low due to the lack of structures other than the small masonry structure housing water pumps at the farmyard.

Airports

The project site is not located within 2 miles of a public airport or a public use airport. The nearest airports to the project site are the Calexico International Airport located approximately 10 miles west of the project site and Holtville Airport located approximately 10 miles north of the project site. According to the Imperial County Airports Department, the Holtville Airport is currently closed.

Fire Hazard

The project site is located in the unincorporated area of Imperial County. According to the Seismic and Public Safety Element of the General Plan, the potential for a major fire in the unincorporated areas of the County is generally low (County of Imperial 1997).

3.9.2 Regulatory Setting

This section identifies and summarizes federal, state, and local laws, policies, and regulations that are applicable to the project.

Federal

Comprehensive Environmental Response, Compensation, and Liability Act

The Comprehensive Environmental Response, Compensation, and Liability Act, commonly known as Superfund, was enacted by Congress on December 11, 1980. This law created a tax on the chemical and petroleum industries and provided broad federal authority to respond directly to releases or threatened releases of hazardous substances that may endanger public health or the environment. Over 5 years, \$1.6 billion was collected and the tax went to a trust fund for cleaning up abandoned or uncontrolled hazardous waste sites. The Comprehensive Environmental Response, Compensation, and Liability Act established prohibitions and requirements concerning closed and abandoned hazardous waste sites; provided for liability of persons responsible for releases of hazardous waste at these sites; and established a trust fund to provide for cleanup when no responsible party could be identified.

Emergency Planning Community Right-to-Know Act of 1986 (42 United States Code 11001 et seq.)

The Emergency Planning Community Right-to-Know Act was included under the Superfund Amendments and Reauthorization Act (SARA) law and is commonly referred to as SARA Title III.

Emergency Planning Community Right-to-Know was passed in response to concerns regarding the environmental and safety hazards posed by the storage and handling of toxic chemicals. These concerns were triggered by the disaster in Bhopal, India, in which more than 2,000 people suffered death or serious injury from the accidental release of methyl isocyanate. To reduce the likelihood of such a disaster in the U.S., Congress imposed requirements on both states and regulated facilities.

Emergency Planning Community Right-to-Know establishes requirements for federal, state, and local governments, Indian Tribes, and industry regarding emergency planning and “Community Right-to-Know” reporting on hazardous and toxic chemicals. SARA Title III requires states and local emergency planning groups to develop community emergency response plans for protection from a list of Extremely Hazardous Substances (40 CFR 355). The Emergency Planning Community Right-to-Know provisions help increase the public’s knowledge and access to information on chemicals at individual facilities, their uses, and releases into the environment. In California, SARA Title III is implemented through the California Accidental Release Prevention.

Federal Insecticide, Fungicide, and Rodenticide Act

The objective of Federal Insecticide, Fungicide, and Rodenticide Act is to provide federal control of pesticide distribution, sale, and use. All pesticides used in the U.S. must be registered (licensed) by the EPA. Registration assures that pesticides would be properly labeled and that, if used in accordance with specifications, they would not cause unreasonable harm to the environment. Use of each registered pesticide must be consistent with use directions contained on the label or labeling.

Federal Water Pollution Control Act (Clean Water Act)

The objective of the Federal Water Pollution Control Act, commonly referred to as the CWA, is to restore and maintain the chemical, physical, and biological integrity of the nation’s waters by preventing point and nonpoint pollution sources, providing assistance to publicly owned treatment works for the improvement of wastewater treatment, and maintaining the integrity of wetlands. The oil SPCC Program of the CWA specifically seeks to prevent oil discharges from reaching waters of the U.S. or adjoining shorelines. Further, farms are subject to the SPCC rule if they:

- Store, transfer, use, or consume oil or oil products
- Could reasonably be expected to discharge oil to waters of the U.S. or adjoining shorelines. Farms that meet these criteria are subject to the SPCC rule if they meet at least one of the following capacity thresholds:
 - Aboveground oil storage capacity greater than 1,320 gallons
 - Completely buried oil storage capacity greater than 42,000 gallons

However, the following are exemptions to the SPCC rule:

- Completely buried storage tanks subject to all the technical requirements of the underground storage tank regulations
- Containers with a storage capacity less than 55 gallons of oil
- Wastewater treatment facilities
- Permanently closed containers
- Motive power containers (e.g., automotive or truck fuel tanks)

Hazardous Materials Transport Act – Code of Federal Regulations

The Hazardous Materials Transportation Act was published in 1975. Its primary objective is to provide adequate protection against the risks to life and property inherent in the transportation of hazardous material in commerce by improving the regulatory and enforcement authority of the Secretary of Transportation. A hazardous material, as defined by the Secretary of Transportation is, any “particular quantity or form” of a material that “may pose an unreasonable risk to health and safety or property.”

Occupational Safety and Health Administration

Occupational Safety and Health Administration’s (OSHA) mission is to ensure the safety and health of America's workers by setting and enforcing standards; providing training, outreach, and education; establishing partnerships; and encouraging continual improvement in workplace safety and health. OSHA standards are listed in 29 CFR Part 1910.

The OSHA Process Safety Management of Highly Hazardous Chemicals (29 CFR Part 110.119) is intended to prevent or minimize the consequences of a catastrophic release of toxic, reactive, flammable, or explosive highly hazardous chemicals by regulating their use, storage, manufacturing, and handling. The standard intends to accomplish its goal by requiring a comprehensive management program integrating technologies, procedures, and management practices.

Resource Conservation and Recovery Act

The goal of the Resource Conservation and Recovery Act, a federal statute passed in 1976, is the protection of human health and the environment, the reduction of waste, the conservation of energy and natural resources, and the elimination of the generation of hazardous waste as expeditiously as possible. The Hazardous and Solid Waste Amendments of 1984 significantly expanded the scope of RCRA by adding new corrective action requirements, land disposal restrictions, and technical requirements. The corresponding regulations in 40 CFR 260-299 provide the general framework for managing hazardous waste, including requirements for entities that generate, store, transport, treat, and dispose of hazardous waste.

State

California Department of Conservation, Division of Oil, Gas, and Geothermal Resources

The Division of Oil, Gas, and Geothermal Resources was formed in 1915 to address the needs of the state, local governments, and industry by regulating statewide oil and gas activities with uniform laws and regulations. The Division supervises the drilling, operation, maintenance, and plugging and abandonment of onshore and offshore oil, gas, and geothermal wells, preventing damage to: (1) life, health, property, and natural resources; (2) underground and surface waters suitable for irrigation or domestic use; and (3) oil, gas, and geothermal reservoirs. The Division’s programs include: well permitting and testing; safety inspections; oversight of production and injection projects; environmental lease inspections; idle-well testing; inspecting oilfield tanks, pipelines, and sumps; hazardous and orphan well plugging and abandonment contracts; and subsidence monitoring.

California Department of Toxic Substances Control

DTSC regulates hazardous waste, cleans-up existing contamination, and looks for ways to reduce the hazardous waste produced in California. Approximately 1,000 scientists, engineers, and specialized support staff are responsible for ensuring that companies and individuals handle, transport, store, treat, dispose of, and clean up hazardous wastes appropriately. Through these measures, DTSC contributes to greater safety for all Californians, and less hazardous waste reaches the environment.

On January 1, 2003, the Registered Environmental Assessor program joined DTSC. The program certifies environmental experts and specialists as being qualified to perform a number of environmental assessment activities. Those activities include private site management, Phase I ESAs, risk assessment, and more.

California Division of Occupational Safety and Health

The California Division of Occupational Safety and Health protects workers and the public from safety hazards through its programs and provides consultative assistance to employers. California Division of Occupational Safety and Health issues permits, provides employee training workshops, conducts inspections of facilities, investigates health and safety complaints, and develops and enforces employer health and safety policies and procedures.

California Environmental Protection Agency

California Environmental Protection Agency and the SWRCB establish rules governing the use of hazardous materials and the management of hazardous waste. Applicable state and local laws include the following:

- Public Safety/Fire Regulations/Building Codes
- Hazardous Waste Control Law
- Hazardous Substances Information and Training Act
- Air Toxics Hot Spots and Emissions Inventory Law
- Underground Storage of Hazardous Substances Act
- Porter-Cologne Water Quality Control Act

Within Cal-EPA, DTSC has primary regulatory responsibility, with delegation of enforcement to local jurisdictions that enter into agreements with the state agency, for the management of hazardous materials and the generation, transport, and disposal of hazardous waste under the authority of the Hazardous Waste Control Law.

California Emergency Response Plan

California has developed an Emergency Response Plan to coordinate emergency services provided by federal, state, and local government and private agencies. Response to hazardous materials incidents is one part of this plan. The plan is managed by the State Office of Emergency Services (OES), which coordinates the responses of other agencies including Cal-EPA, the California Highway Patrol, CDFW, RWQCB, Imperial County Sheriff's Department, ICFD, and the City of Imperial Police Department.

Local

Imperial County General Plan

The Seismic and Public Safety Element identifies goals and policies that will minimize the risks associated with natural and human-made hazards and specify the land use planning procedures that should be implemented to avoid hazardous situations. The purpose of the Seismic and Public Safety Element is to reduce the loss of life, injury, and property damage that might result from disaster or accident. In addition, the Element specifies land use planning procedures that should be implemented to avoid hazardous situations. The policies listed in the Seismic and Public Safety Element are not applicable to the proposed project, as they address human occupancy development. The proposed project is a solar project and does not propose residential uses.

Imperial County Public Health Department

Hazardous Materials and Medical Waste Management

DTSC was appointed the Certified Unified Program Agency (CUPA) for Imperial County in January 2005. The Unified Program is the consolidation of 6 state environmental programs into one program under the authority of a CUPA. The CUPA inspects businesses or facilities that handle or store hazardous materials, generate hazardous waste, own or operate ASTs or USTs, and comply with the California Accidental Release Prevention Program. The CUPA Program is instrumental in accomplishing this goal through education, community and industry outreach, inspections and enforcement.

Office of Emergency Services

As part of the ICFD, the County OES is mandated by the California Emergency Services Act (Chapter 7, Division 1, Title 2 of Government Code) to serve as the liaison between the State and all the local government in the County. The OES provides centralized emergency management during major disasters, and coordinates emergency operations between various local jurisdictions within the County. The OES has developed several plans, consistent with federal and state policy guidance, to provide the County and participating local jurisdictions and agencies a framework for conducting emergency planning, response, and recovery operations, and handling of hazardous substances.

3.9.3 Impacts and Mitigation Measures

This section presents the significance criteria used for considering project-related impacts related to hazards and hazardous materials, the methodology employed for the evaluation, and mitigation requirements, if necessary.

Thresholds of Significance

Based on CEQA Guidelines Appendix G, project impacts related to hazards and hazardous materials are considered significant if any of the following occur:

- Create a significant hazard to the public or the environment through the routine transport, use, or disposal of hazardous materials
- Create a significant hazard to the public or the environment through reasonably foreseeable upset and accident conditions involving the release of hazardous materials into the environment

- Emit hazardous emissions or handle hazardous or acutely hazardous materials, substances, or waste within 0.25 mile of an existing or proposed school
- Be located on a site which is included on a list of hazardous materials sites compiled pursuant to Government Code Section 65962.5 and, as a result, would create a significant hazard to the public or the environment
- For a project located within an airport land use plan or, where such a plan has not been adopted, within 2 miles of a public airport or public use airport, result in a safety hazard or excessive noise for people residing or working in the project area
- Impair implementation of or physically interfere with an adopted emergency response plan or emergency evacuation plan
- Expose people or structures, either directly or indirectly, to a significant risk of loss, injury or death involving wildland fires

Methodology

This analysis evaluates the potential for the project, as described in Chapter 2, Project Description to result in significant impacts related to hazards and hazardous materials on or within the 1-mile buffer zone of the project site. This analysis considers whether these conditions would result in an exceedance of one or more of the applied significance criteria as identified above.

A Phase I ESA has been prepared for the project site. The information obtained from the Phase I ESA was reviewed and summarized to present the existing conditions, in addition to identifying potential environmental impacts, based on the significance criteria presented above. Impacts associated with hazards and hazardous materials that could result from project construction and operational activities were evaluated qualitatively based on site conditions; expected construction practices; materials, locations, duration of project construction, and related activities. The conceptual site plan (Figure 2-3) for the project was also used to evaluate potential impacts.

Impact Analysis

Impact 3.9-1 Would the project create a significant hazard to the public or the environment through the routine transport, use, or disposal of hazardous materials?

Although considered minimal, it is anticipated that the proposed project will generate the following materials during construction, operation, and long-term maintenance: insulating oil (used for electrical equipment), lubricating oil (used for maintenance vehicles), various solvents/detergents (equipment cleaning), and gasoline (used for maintenance vehicles). These materials have the potential to be released into the environment as a result of natural hazard (i.e., earthquake) related events, or because of human error. However, all materials contained on site will be stored in appropriate containers (not to exceed a 55-gallon drum) protected from environmental conditions, including rain, wind, and direct heat and physical hazards such as vehicle traffic and sources of heat and impact. In addition, if the on-site storage of hazardous materials necessitate, at any time during construction and/or operations and long-term maintenance, quantities in excess of 55-gallons, a hazardous material management program (HMMP) would be required. The HMMP developed for the project will include, at a minimum, procedures for:

- Hazardous materials handling, use and storage

- Emergency response
- Spill control and prevention
- Employee training
- Record keeping and reporting

Spill response plans would be developed prior to project construction and operation or prior to the storage on-site of an excess of 55 gallons of hazardous materials, and personnel would be made aware of the procedures for spill cleanup and the procedures to report a spill. Spill cleanup materials and equipment appropriate to the type and quantity of chemicals and petroleum products expected would be located onsite and personnel shall be made aware of their location.

The small quantities of chemicals to be stored at the project site during construction include equipment and facilities maintenance chemicals. These materials would be stored in their appropriate containers in an enclosed and secured location, such as portable outdoor hazardous materials storage cabinets equipped with secondary containment to prevent contact with rainwater. The portable chemical storage cabinets may be moved to different locations around the project site as construction activity locations shift. The chemical storage area would not be located immediately adjacent to any drainage. Disposal of excess materials and wastes would be performed in accordance with local, state, and federal regulations.

Additionally, hazardous material storage and management will be conducted in accordance with requirements set forth by the ICFD, Imperial County Office of Emergency Services, DTSC, and CUPA for storage and handling of hazardous materials. Further, construction activities would occur according to OSHA regulatory requirements; therefore, it is not anticipated that the construction activities for the proposed project would release hazardous emissions or result in the handling of hazardous or acutely hazardous materials, substances, or waste. This could include the release of hazardous emissions, materials, substances, or wastes during operational activities. With the implementation of an HMMP and adherence to requirements set forth by the ICFD, Imperial County Office of Emergency Services, DTSC, OSHA regulatory requirements and CUPA, the impact associated with the possible risk to the public or environment through routine transport, use, or disposal of hazardous materials would be considered less than significant.

Battery Energy Storage System

In conjunction with the construction of the solar facility, a 100 MW battery ESS will be constructed to store the energy generated by the solar panels on the northern boundary of APN 059-300-015. Transportation of hazardous materials relating to the battery ESS includes electrolyte and graphite and would occur during construction, operation (if replacement of batteries is needed) and decommissioning (removal of the batteries). All of these various materials would be transported and handled in compliance with DTSC regulations. Therefore, likelihood of an accidental release during transport or residual contamination following accidental release is not anticipated.

Lithium-ion batteries used in the storage system contain cobalt oxide, manganese dioxide, nickel oxide, carbon, electrolyte, and polyvinylidene fluoride. Of these chemicals, only electrolyte should be considered hazardous, inflammable and could react dangerously when mixed with water. The U.S. Department of Transportation (DOT) regulates transport of lithium-ion batteries under the DOT's Hazardous Materials Regulations (HMR; 49 C.F.R., Parts 171-180). The HMR apply to any material DOT determines is capable of posing an unreasonable risk to health, safety, and property when

transported in commerce. Lithium-ion batteries must conform to all applicable HMR requirements when offered for transportation or transported by air, highway, rail, or water (DOT 2021). Additionally, carbon (as graphite) is flammable and could pose a fire hazard. As further detailed below, fire protection is achieved through project design features, such as monitoring, diagnostics and a fire suppression system. The project would be required to comply with state laws and county ordinance restrictions, which regulate and control hazardous materials handled on site.

Construction wastes would be disposed of in accordance with local, state, and federal regulations, and recycling will be used to the greatest extent possible. In this context, with adherence to requirements set forth by the ICFD, Imperial County OES, DTSC, OSHA regulatory requirements and CUPA, impacts would be less than significant.

Mitigation Measure(s)

No mitigation measures are required.

Impact 3.9-2 Would the project create a significant hazard to the public or the environment through reasonably foreseeable upset and accident conditions involving the release of hazardous materials into the environment?

According to the historical records search, the project site has been in agricultural use and/or vacant since the 1930s. Typical agricultural practices in the Imperial Valley consist of aerial and ground application of pesticides and the application of chemical fertilizers to both ground and irrigation water. GS Lyon professionals have reported that concentrations of pesticides are limited and typically less than 25 percent of the current regulatory threshold limits of EPA preliminary remediation goals.

The Federal Insecticide, Fungicide, and Rodenticide Act provides federal control of pesticide distribution, sale, and use. Pesticides used in the United States must be registered by the EPA to assure that pesticides are properly labeled and that they will not cause unreasonable harm to the environment. The construction phase, operations and long-term maintenance of the facility would not result in additional application of pesticides or fertilizers. Therefore, a less than significant impact has been identified for this issue area.

Hazardous Materials

The Phase I ESA (Appendix H of this EIR) prepared for the project site did not identify any recognized environmental conditions (RECs) or USTs. According to the local DTSC record searches and interviews with individuals familiar with the subject property, there are no potential RECs existing on the project site. However, one AST was observed within the fenced farmyard within the project site. Access to the AST was not available at the time of the site reconnaissance. If it is shown that spills or leaks had occurred, the affected soil shall be cleaned up and properly disposed according to the HMMP. Several steel 55-gallon drums were also observed on the subject property and no fluids were observed in the drums that were accessible. No other drums or storage containers, nor any open or damaged containers containing unidentified substances were observed at the project site. With adherence to requirements set forth by the ICFD, Imperial County Office of Emergency Services, DTSC, OSHA regulatory requirements and CUPA, impacts would be less than significant.

Lead and Asbestos

According to records research and the reconnaissance survey, the potential for lead-based paint residues and asbestos containing materials is very low because of the lack of site development. Therefore, a less than significant impact is identified for this issue area.

Battery Energy Storage System

Protection would be provided as part of the project design by housing the battery units in enclosed structures to provide containment should a fire break out or for potential spills. Any potential fire risk that the traditional lithium-ion cells have will most likely be caused by over-charging or through short circuit due to age. This risk will be mitigated through monitoring and a fire suppression system that includes water and or a suppression agent (eg FM-200, Novatech) with smoke detectors, control panel, alarm, piping and nozzles. The fire protection system will be designed by a certified fire protection engineer and installed by a fire protection system contractor licensed in California and in accordance with all relevant building and fire codes in effect in the County at the time of building permit submission. Fire protection systems for battery systems would be designed in accordance with California Fire Code and would take into consideration the recommendations of the National Fire Protection Association (NFPA) 855.

The fire protection plan is anticipated to include a combination of prevention, suppression, and isolation methods and materials. The general approach to fire mitigation at the project site would be prevention of an incident, followed by attempts to isolate and control the incident to the immediately affected equipment, then to suppress any fire with a clean agent so as to reduce damage to uninvolved equipment. Fire suppression agents such as Novec 1230 or FM 2000, or water may be used as a suppressant. In addition, fire prevention methods would be implemented to reduce potential fire risk, including voltage, current, and temperature alarms. Energy storage equipment would comply with Underwriters Laboratory (UL)-95401 and test methods associated with UL-9540A. For lithium-ion batteries storage, a system would be used that would contain the fire event and encourage suppression through cooling, isolation, and containment. Suppressing a lithium-ion (secondary) battery is best accomplished by cooling the burning material. A gaseous fire suppressant agent (e.g., 3M™ Novec™ 1230 Fire Protection Fluid or similar) and an automatic fire extinguishing system with sound and light alarms would be used for lithium-ion batteries.

To mitigate potential hazards, redundant separate methods of failure detection would be implemented. These would include alarms from the Battery Management System (BMS), including voltage, current, and temperature alarms. Detection methods for off gas detection would be implemented, as applicable. These are in addition to other potential protective measures such as ventilation, overcurrent protection, battery controls maintaining batteries within designated parameters, temperature and humidity controls, smoke detection, and maintenance in accordance with manufacturer guidelines. Remote alarms would be installed for operations personnel as well as emergency response teams in addition to exterior hazard lighting. In addition, an Incidence Response Plan would be implemented. In this context, impacts would be considered less than significant for this impact area.

Mitigation Measure(s)

No mitigation measures are required.

Impact 3.9-3 Would the project emit hazardous emissions or handle hazardous or acutely hazardous materials, substances, or waste within 0.25 mile of an existing or proposed school?

The project site is not located within 0.25 mile of any existing or proposed schools. Therefore, the proposed project would not pose a risk to nearby schools and no impact would occur.

Mitigation Measure(s)

No mitigation measures are required.

Impact 3.9-4 Would the project be located on a site which is included on a list of hazardous materials sites compiled pursuant to Government Code Section 65962.5 and, as a result, would create a significant hazard to the public or the environment?

The project site is not identified in the EDR report as being located on a hazardous materials site pursuant to Government Code Section 65962.5. Implementation of the proposed project would result in no impact related to the project site being located on a listed hazardous materials site.

Mitigation Measure(s)

No mitigation measures are required.

Impact 3.9-5 For a project located within an airport land use plan or, where such a plan has not been adopted, within 2 miles of a public airport or public use airport, result in a safety hazard or excessive noise for people residing or working in the project area?

The project site is not located within 2 miles of a public airport. The nearest airports to the project site are the Calexico International Airport located approximately 10 miles west of the project site and Holtville Airport located approximately 10 miles north of the project site. According to the Imperial County Airports Department, the Holtville Airport is currently closed. According to Figure 3B of the ALUCP, no portion of the project site is located within the Calexico International Airport's land use compatibility zones (County of Imperial 1996). Therefore, implementation of the proposed project would not result in a safety hazard or excessive noise for people residing or working in the project area and no impact would occur.

Mitigation Measure(s)

No mitigation measures are required.

Impact 3.9-6 Would the project impair implementation of or physically interfere with an adopted emergency response plan or emergency evacuation plan?

The Imperial County Operational Area Emergency Operations Plan (Imperial County OES 2016) does not identify specific emergency roadway routes as part of their emergency operations plan (EOP). The Circulation & Scenic Highways Element of the General Plan (County of Imperial 2008) identifies SR-98 and SR-7/S-32, which are adjacent to the project site and provide regional and local connections, as major access routes and corridors.

The applicant for the proposed project will be required, through the conditions of approval, to prepare a street improvement plan for the project that will include emergency access points and safe vehicular travel. Additionally, local building codes would be followed to minimize flood, seismic, and fire hazard. Therefore, the proposed project would result in a less than significant impact associated with the possible impediment to emergency response plans or emergency evacuation plans.

Mitigation Measure(s)

No mitigation measures are required.

Impact 3.9-7 Would the project expose people or structures, either directly or indirectly, to a significant risk of loss, injury or death involving wildland fires?

The project site is located in the unincorporated area of Imperial County. According to the Seismic and Public Safety Element of the General Plan (County of Imperial 1997), the potential for a major fire in the unincorporated areas of the County is generally low.

Proposed project facilities would be designed, constructed, and operated in accordance with applicable fire protection and other environmental, health, and safety requirements (e.g., CPUC safety standards). PV panels would be spaced to maintain proper clearance for emergency access. Internal access roads, up to 30-feet wide, would be constructed along the perimeter fence and solar panels to facilitate vehicle access and maneuverability for emergency unit vehicles. Access roads would be graded and compacted (native soils) as required for construction, operations, maintenance, and emergency vehicle access. The access and service roads would also have turnaround areas at any dead-end to allow clearance for fire trucks per fire department standards. The access and service roads would also have turnaround areas at any dead-end to allow clearance for fire trucks per fire department standards.

Because the proposed project is not located in proximity to an area susceptible to wildland fires, implementation of the proposed project would result in a less than significant impact related to the possible risk to people or structures caused by wildland fires.

Mitigation Measure(s)

No mitigation measures are required.

3.9.4 Decommissioning/Restoration and Residual Impacts

Decommissioning/Restoration

During decommissioning and restoration of the project site, the applicant or its successor in interest would be responsible for the removal, recycling, and/or disposal of all solar arrays, inverters, battery storage system, transformers and other structures on each of the project site. The project applicant anticipates using the best available recycling measures at the time of decommissioning. Any potentially hazardous materials located on the site would be disposed of, and/or remediated prior to construction of the solar facilities.

The operation of the solar facility would not generate hazardous wastes and therefore, implementation of applicable regulations and mitigation measures identified for construction and operations would ensure restoration of the project site to pre-project conditions during the decommissioning process in a manner that would be less than significant. Furthermore, decommissioning/restoration activities would not result in a potential impact associated with ALUCP

consistency (structures would be removed and the site would remain in an undeveloped condition), wildfires (fire protection measures), or impediment to an emergency plan (the undeveloped condition as restored, would not conflict with emergency plans).

Residual

Adherence to federal, state, and local regulations will ensure that impacts related to the transportation of hazardous materials and potential fires would be reduced to levels less than significant. Based on these circumstances, the proposed project would not result in residual significant and unmitigable impacts related to hazards and hazardous materials.

3.10 Hydrology/Water Quality

This section provides a description of existing water resources within the project site and pertinent local, state, and federal plans and policies. Each subsection includes descriptions of existing hydrology/drainage, existing flooding hazards, and the environmental impacts on hydrology and water quality resulting from implementation of the proposed project, and mitigation measures where appropriate. The impact assessment provides an evaluation of potential effects to water quality based on criteria derived from CEQA Guidelines in conjunction with actions proposed in Chapter 2, Project Description.

3.10.1 Existing Conditions

Drainage

The project site is located in the Imperial Valley Planning Area of the Colorado River Basin. The Colorado River Basin Region covers approximately 13 million acres (20,000 square miles) in the southeastern portion of California. It includes all of Imperial County and portions of San Bernardino, Riverside, and San Diego Counties. The Colorado River Basin Region is divided into seven major planning areas on the basis of different economic and hydrologic characteristics (California RWQCB 2019). The Imperial Valley Planning Area consists of the following HUs: Imperial (723.00) comprised of 2,500 square miles in the southern portion of the Colorado River Basin Region, with the majority located in Imperial County; Davies (724.00), and Amos-Ogilby (726.00). The project site is located within the Imperial HU.

The Imperial HU consists of the majority of the Imperial Valley, encompassing over 1.3 million acres of land. The watershed includes vast acreages of agricultural land; towns such as El Centro, Calexico, and Brawley, along with a large network of IID operated canals and drains. The watershed is atypical of most watersheds in California, as it currently and historically has been shaped by man-made forces. The watershed's primary watercourses, the New and Alamo rivers, flow north, from the Mexican border toward their final destination, the Salton Sea. The Salton Sea, a 376 square mile closed inland lake was created in 1905 through a routing mistake and subsequent flood on the Colorado River. The sea has been fed primarily by agricultural runoff from the New and Alamo Rivers ever since that time.

The project site is within the Salton Sea watershed, Hydrologic Unit Code 18100204. The project site is downslope of the All-American Canal, which brings water from the Colorado River at the Imperial Dam, and then supplies it to the Imperial Valley through smaller lateral canals, all of which drain to the Salton Sea.

Runoff from adjacent agricultural land collects and is concentrated in the project site. Runoff within the project site generally flows south from the direction of the All-American Canal, toward the U.S.-Mexico border, and eventually drains into a playa at the south end of the site. Manmade berms running north-south line ephemeral drainages present throughout the western portion of the project site. The All-American Canal and groundwater likely feed the drainages and wetlands present onsite.

Flooding

According to the Federal Emergency Management Agency (FEMA) Flood Insurance Rate Map (Panel 06025C2125C) (FEMA 2008), the project site is within Zone X, which is an area determined to be outside of the 0.2 percent annual chance of a flood.

Surface Water Quality

The surface waters of the Imperial Valley depend primarily on the inflow of irrigation water from the Colorado River via the All-American Canal. Excessive salinity concentrations have long been one of the major water quality problems of the Colorado River, a municipal and industrial water source to millions of people, and a source of irrigation water for approximately 700,000 acres of farmland. The heavy salt load in the Colorado River results from both natural and human activities. Land use and water resources are unequivocally linked. A variety of natural and human factors can affect the quality and use of streams, lakes, and rivers. Surface waters may be impacted from a variety of point and non-point discharges. Examples of point sources may include wastewater treatment plants, industrial discharges, or any other type of discharge from a specific location (commonly a large-diameter pipe) into a stream or water body. In contrast, non-point source pollutant sources are generally more diffuse in nature and connected to a cumulative contribution of multiple smaller sources.

Common non-point source contaminants within the project area may include, but are not limited to: sediment, nutrients (phosphorous and nitrogen), trace metals (e.g., lead, zinc, copper, nickel, iron, cadmium, and mercury), oil and grease, bacteria (e.g., coliform), viruses, pesticides and herbicides, organic matter, and solid debris/litter. Vehicles account for most of the heavy metals, fuel and fuel additives (e.g., benzene), motor oil, lubricants, coolants, rubber, battery acid, and other substances. Nutrients result from excessive fertilizing of agricultural areas, while pesticides and herbicides are widely used in agricultural fields and roadway shoulders for keeping right-of-way (ROW) areas clear of vegetation and pests.

Based on the 305(b)/303(d) Integrated Report prepared by the Colorado River Basin RWQCB (RWQCB 2018), the following water features within the Brawley Hydrologic Area includes the Imperial Valley Drains (Wistaria Drain and Greeson Wash), New River, and the Salton Sea. Specific impairments listed for each of these water bodies (or Category 5) are identified below:

- Imperial Valley Drains: Impaired for pesticides (toxaphene, chlorpyrifos, dieldrin, chlordane, dichlorodiphenyltrichloroethane, and imidacloprid), metals (selenium), sediment/siltation, total toxics, and organic toxics (polychlorinated biphenyls);
- New River: Impaired for pesticides (toxaphene, chlorpyrifos, dieldrin, chlordane, hexachlorobenzene, dichlorodiphenyltrichloroethane, diazinon, cyhalothrin, lambda, cypermethrin, bifenthrin, malathion, disulfoton, imidacloprid), metals (selenium and mercury), sediment/siltation, nutrients (organic enrichment), trash, pathogens (indicator bacteria), organic toxics (polychlorinated biphenyls and naphthalene), total toxics, and dissolved salts (chloride);
- All-American Canal: Impaired for pesticides (dichlorodiphenyltrichloroethane);
- Salton Sea: pesticides (chlorpyrifos and dichlorodiphenyltrichloroethane), metals (arsenic), pathogens (Enterococcus), nutrients (ammonia and low dissolved oxygen), total toxics, and dissolved salts (chloride).

Groundwater Hydrology

The project site is located within the Imperial Valley Groundwater Basin (Basin No: 7-30), which covers approximately 1,870 surface square miles. The physical groundwater basin extends in the southeastern portion of California at the border with Mexico. The basin lies within the southern part of the Colorado Desert Hydrologic Region, south of the Salton Sea. The basin has two major



aquifers, separated at depth by a semi-permeable aquitard that averages 60 feet thick and reaches a maximum thickness of 280 feet. The average thickness of the upper aquifer is 200 feet with a maximum thickness of 450 feet. The data regarding faults controlling groundwater movement is uncertain; however, as much as 80 feet of fine-grained, low permeability prehistoric lake deposits have accumulated on the valley floor, which result in locally confined aquifer conditions.

Groundwater recharge within the basin is primarily from irrigation return. Other recharge sources are deep percolation of rainfall and surface runoff, underflow into the basin, and seepage from unlined canals which traverse the valley. Groundwater levels within a majority of the basin have remained stable from 1970 to 1990 because of relatively constant recharge and an extensive network of subsurface drains.

Groundwater quality varies extensively throughout the base; however, is generally unusable for domestic and irrigation purposes without treatment (California Department of Water Resources 2004).

3.10.2 Regulatory Setting

This section identifies and summarizes federal, state, and local laws, policies, and regulations that are applicable to the project.

Federal

Clean Water Act

The U.S. EPA is the lead federal agency responsible for managing water quality. The CWA of 1972 is the primary federal law that governs and authorizes the U.S. EPA and the states to implement activities to control water quality. The various elements of the CWA that address water quality and that are applicable to the project are discussed below. Wetland protection elements administered by the USACE under Section 404 of the CWA, including permits for the discharge of dredged and/or fill material into waters of the United States, are discussed in Section 3.5, Biological Resources.

Under federal law, the U.S.EPA has published water quality regulations under Volume 40 of the CFR. Section 303 of the CWA requires states to adopt water quality standards for all surface waters of the U.S. As defined by the CWA, water quality standards consist of two elements: (1) designated beneficial uses of the water body in question; and (2) criteria that protect the designated uses. Section 304(a) requires the U.S.EPA to publish advisory water quality criteria that accurately reflect the latest scientific knowledge on the kind and extent of all effects on health and welfare that may be expected from the presence of pollutants in water. Where multiple uses exist, water quality standards must protect the most sensitive use. The U.S. EPA is the federal agency with primary authority for implementing regulations adopted under the CWA. The U.S.EPA has delegated the State of California the authority to implement and oversee most of the programs authorized or adopted for CWA compliance through the Porter-Cologne Water Quality Control Act of 1969 (Porter-Cologne Act), described below.

Under CWA Section 401, applicants for a federal license or permit to conduct activities that may result in the discharge of a pollutant into waters of the U.S. must obtain a water quality certification from the SWRCB in which the discharge would originate or, if appropriate, from the interstate water pollution control agency with jurisdiction over affected waters at the point where the discharge would originate.

CWA Section 402 establishes the National Pollution Discharge Elimination System (NPDES) permit program to control point source discharges from industrial, municipal, and other facilities if their discharges go directly to surface waters. The 1987 amendments to the CWA created a new section of the CWA devoted to regulating storm water or nonpoint source discharges (Section 402[p]). The U.S.EPA has granted California primacy in administering and enforcing the provisions of the CWA and the NPDES program through the SWRCB. The SWRCB is responsible for issuing both general and individual permits for discharges from certain activities. At the local and regional levels, general and individual permits are administered by RWQCBs.

Clean Water Act Section 303(d) Impaired Waters List

CWA Section 303(d) requires states to develop lists of water bodies that will not attain water quality standards after implementation of minimum required levels of treatment by point-source dischargers. Section 303(d) requires states to develop a total maximum daily load (TMDL) for each of the listed pollutants and water bodies. A TMDL is the amount of loading that the water body can receive and still be in compliance with applicable water quality objectives and applied beneficial uses. TMDLs can also act as a planning framework for reducing loadings of a specific pollutant from various sources to achieve compliance with water quality objectives. TMDLs prepared by the state must include an allocation of allowable loadings to point and nonpoint sources, with consideration of background loadings and a margin of safety. The TMDL must also include an analysis that shows links between loading reductions and the attainment of water quality objectives.

National Flood Insurance Program

The Federal Emergency Management Agency (FEMA) administers the National Flood Insurance Program (NFIP) to provide subsidized flood insurance to communities that comply with FEMA regulations that limit development in floodplains. FEMA also issues Flood Insurance Rate Maps (FIRM) that identify which land areas are subject to flooding. These maps provide flood information and identify flood hazard zones in the community. The design standard for flood protection covered by the FIRM is established by FEMA, with the minimum level of flood protection for new development determined to be the 1-in-100 (0.01) annual exceedance probability) (i.e., the 100-year flood event).

State

Porter-Cologne Water Quality Control Act

The Porter-Cologne Water Quality Control Act, also known as the California Water Code, is California's statutory authority for the protection of water quality. Under this act, the state must adopt water quality policies, plans, and objectives that protect the state's waters. The act sets forth the obligations of the State Water Resources Control Board (SWRCB) and RWQCBs pertaining to the adoption of Water Quality Control Plans and establishment of water quality objectives. Unlike the CWA, which regulates only surface water, the Porter-Cologne Act regulates both surface water and groundwater.

Water Quality Control Plan for the Colorado River Basin

The Water Quality Control Plan for the Colorado River Basin (or Basin Plan) prepared by the Colorado River RWQCB (Region 7) identifies beneficial uses of surface waters within the Colorado River Basin region, establishes quantitative and qualitative water quality objectives for protection of



beneficial uses, and establishes policies to guide the implementation of these water quality objectives.

Water bodies that have beneficial uses that may be affected by construction activity and post-construction activity include the Imperial Valley Drains and the Salton Sea. Table 3.10-1 identifies the designated beneficial uses established for the project site’s receiving waters. The following are definitions of the applicable beneficial uses:

- Aquaculture (AQUA) – Uses of water for aquaculture or mariculture operations including, but not limited to, propagation, cultivation, maintenance, or harvesting of aquatic plants and animals for human consumption or bait purposes.
- Freshwater Replenishment (FRSH) – Uses of water for natural or artificial maintenance of surface water quantity or quality.
- Industrial Service Supply (IND) – Uses of water for industrial activities that do not depend primarily on water quality including, but not limited to, mining, cooling water supply, hydraulic conveyance, gravel washing, fire protection, and oil well repressurization.
- Water Contact Recreation (REC I) – Uses of water for recreational activities involving body contact with water, where ingestion of water is reasonably possible. These uses include, but are not limited to, swimming, wading, water-skiing, skin and scuba diving, surfing, white water activities, fishing, and use of natural hot springs.
- Non-contact Water Recreation (REC II) – Uses of water for recreational activities involving proximity to water, but not normally involving contact with water where ingestion of water is reasonably possible. These uses include, but are not limited to, picnicking, sunbathing, hiking, beachcombing, camping, boating, tide pool and marine life study, hunting, sightseeing, or aesthetic enjoyment in conjunction with the above activities.
- Warm Freshwater Habitat (WARM) – Uses of water that support warm water ecosystems including, but not limited to, preservation or enhancement of aquatic habitats, vegetation, fish, or wildlife, including invertebrates.
- Wildlife Habitat (WILD) – Uses of water that support terrestrial ecosystems including, but not limited to, the preservation and enhancement of terrestrial habitats, vegetation, wildlife (e.g., mammals, birds, reptiles, amphibians, invertebrates), or wildlife water and food sources.
- Preservation of Rare, Threatened, or Endangered Species (RARE) – Uses of water that support habitats necessary, at least in part, for the survival and successful maintenance of plant or animal species established under state or federal law as rare, threatened or endangered.

Table 3.10-1. Beneficial Uses of Receiving Waters

Beneficial Uses	Imperial Valley Drains	Salton Sea
AQUA	--	X
FRSH	X	--
IND	--	P
REC I	X	X
REC II	X	X

Table 3.10-1. Beneficial Uses of Receiving Waters

Beneficial Uses	Imperial Valley Drains	Salton Sea
WARM	X	X
WILD	X	X
RARE	X	X

Source: SWRCB 2019

AQUA=aquaculture; FRSH=freshwater replenishment; IND=industrial service supply; P=Potential Uses; RARE=Preservation of Rare, Threatened, or Endangered Species; REC 1= water contact recreation; REC II=non-contact water recreation; WARM=Warm Freshwater Habitat; WILD=Wildlife Habitat; X=existing beneficial uses

National Pollution Discharge Elimination System General Industrial and Construction Permits

The NPDES General Industrial Permit requirements apply to the discharge of stormwater associated with industrial sites. The permit requires implementation of management measures that will achieve the performance standard of the best available technology economically achievable and best conventional pollutant control technology. Under the statute, operators of new facilities must implement industrial BMPs in the projects' SWPPP and perform monitoring of stormwater discharges and unauthorized non-stormwater discharges.

Construction activities are regulated under the NPDES General Permit for Discharges of Storm Water Runoff Associated with Construction Activity (General Construction Permit) which covers stormwater runoff requirements for projects where the total amount of ground disturbance during construction exceeds 1 acre. Coverage under a General Construction Permit requires the preparation of a SWPPP and submittal of a Notice of Intent (NOI) to comply with the General Construction Permit. The SWPPP includes a description of BMPs to minimize the discharge of pollutants from the sites during construction. Typical BMPs include temporary soil stabilization measures (e.g., mulching and seeding), storing materials and equipment to ensure that spills or leaks cannot enter the storm drain system or stormwater, and using filtering mechanisms at drop inlets to prevent contaminants from entering storm drains. Typical post-construction management practices include street sweeping and cleaning stormwater drain inlet structures. The NOI includes site-specific information and the certification of compliance with the terms of the General Construction Permit.

Local

County of Imperial General Plan

The Water Element and the Conservation and Open Space Element of the General Plan contain policies and programs, created to ensure water resources are preserved and protected. Table 3.10-2 identifies the General Plan policies and programs for water quality and flood hazards that are relevant to the project and summarizes the project's consistency with the General Plan. While this EIR analyzes the project's consistency with the General Plan pursuant to CEQA Guidelines Section 15125(d), the Imperial County Board of Supervisors ultimately determines consistency with the General Plan.



Table 3.10-2. Project Consistency with Applicable General Plan Policies

General Plan Policies	Consistency with General Plan	Analysis
<i>Conservation and Open Space Element</i>		
<p>Goal 6: The County will conserve, protect, and enhance water resources in the County.</p>	<p>Consistent</p>	<p>The proposed project would protect water quality during construction through compliance with Imperial County design and detention requirements and the NPDES General Construction Permit, as well as preparation and implementation of a project-specific SWPPP, which will incorporate the requirements referenced in the State Regulatory Framework, design features, and BMPs.</p>
<p>Objective 6.3: Protect and improve water quality and quantity for all water bodies in Imperial County.</p>	<p>Consistent</p>	<p>The proposed project would protect water quality during construction through compliance with the NPDES General Construction Permit, SWPPP, and BMPs. Implementation of Mitigation Measure HYD-2 would require the project to incorporate post-construction BMPs into the proposed project's drainage plans. The proposed project will be designed to include site design, source control, and treatment control BMPs. The use of source control, site design, and treatment BMPs would result in a decrease potential for storm water pollution.</p>
<p>Program: Structural development normally shall be prohibited in the designated floodways. Only structures which comply with specific development standards should be permitted in the floodplain.</p>	<p>Consistent</p>	<p>The proposed project does not contain a residential component, nor would it place housing or other structures within a 100-year flood hazard area.</p>
<i>Water Element</i>		
<p>Policy: Adoption and implementation of ordinances, policies, and guidelines which assure the safety of County ground and surface waters from toxic or hazardous materials and/or wastes.</p>	<p>Consistent</p>	<p>The project would preserve ground and surface water quality from hazardous materials and wastes during construction, operation and decommissioning activities. The proposed project would protect water quality during construction through compliance with NPDES General Construction Permit SWPPP, which will incorporate the requirements referenced in the State Regulatory Framework and BMPs. Implementation of Mitigation Measure HYD-2 would require the project to incorporate post-construction BMPs into the project's drainage plan. The proposed project will be designed to include site design, source control, and treatment control BMPs. The use of source control, site design, and treatment BMPs would result in a decrease potential for storm water pollution. It is anticipated that decommissioning activities would be subject to similar, or more stringent ground and surface water regulations than those currently required.</p>

Table 3.10-2. Project Consistency with Applicable General Plan Policies

General Plan Policies	Consistency with General Plan	Analysis
Program: The County of Imperial shall make every reasonable effort to limit or preclude the contamination or degradation of all groundwater and surface water resources in the County.	Consistent	Mitigation measures will require that the applicant of the proposed project prepare a site-specific drainage plan and water quality management plan to minimize adverse effects to local water resources.
Program: All development proposals brought before the County of Imperial shall be reviewed for potential adverse effects on water quality and quantity and shall be required to implement appropriate mitigation measures for any significant impacts.	Consistent	See response for Water Element Policy above.

Source: County of Imperial 2016; County of Imperial 1997b

County of Imperial Land Use Ordinance, Title 9

The County’s Ordinance Code provides specific direction for the protection of water resources. Applicable ordinance requirements are contained in Division 10, Building, Sewer and Grading Regulations, and summarized below.

Chapter 10 – Grading Regulations. Section 91010.02 of the Ordinance Code outlines conditions required for issuance of a Grading Permit. These specific conditions include:

1. If the proposed grading, excavation or earthwork construction is of irrigatable land, said grading will not cause said land to be unfit for agricultural use.
2. The depth of the grading, excavation or earthwork construction will not preclude the use of drain tiles in irrigated lands.
3. The grading, excavation or earthwork construction will not extend below the water table of the immediate area.
4. Where the transition between the grading plane and adjacent ground has a slope less than the ratio of 1.5 feet on the horizontal plane to 1 foot on the vertical plane, the plans and specifications will provide for adequate safety precautions.

Imperial County Engineering Design Guidelines Manual for the Preparation and Checking of Street Improvement, Drainage and Grading Plans within Imperial County

Based on the guidance contained in the County’s *Engineering Guidelines Design Guidelines Manual for the Preparation and Checking of Street Improvement, Drainage and Grading Plans within Imperial County* (2008), the following drainage requirements would be applicable to the proposed projects.

III A. GENERAL REQUIREMENTS

1. All drainage design and requirements are recommended to be in accordance with the IID “Draft” Hydrology Manual or other recognized source with approval by the County Engineer and based on full development of upstream tributary basins. Another source is the Caltrans I-D-F curves for the Imperial Valley.

3. Permanent drainage facilities and ROW, including access, shall be provided from development to point of satisfactory disposal.
4. Retention volume on retention or detention basins should have a total volume capacity for a three (3) inch minimum precipitation covering the entire site with no C reduction factors. Volume can be considered by a combination of basin size and volume considered within parking and/or landscaping areas.

There is no guarantee that a detention basin outletting to an IID facility or other storm drain system will not back up should the facility be full and unable to accept the project runoff. This provides the safety factor from flooding by ensuring each development can handle a minimum 3-inch precipitation over the project site.

8. The developer shall submit a drainage study and specifications for improvements of all drainage easements, culverts, drainage structures, and drainage channels to the Department of Public Works for approval. Unless specifically waived herein, required plans and specifications shall provide a drainage system capable of handling and disposing of all surface waters originating within the subdivision and all surface waters that may flow onto the subdivision from adjacent lands. Said drainage system shall include any easements and structures required by the Department of Public Works or the affected Utility Agency to properly handle the drainage on-site and off-site. The report should detail any vegetation and trash/debris removal, as well as address any standing water.
9. Hydrology and hydraulic calculations for determining the storm system design shall be provided to the satisfaction of the Director, Department of Public Works. When appropriate, water surface profiles and adequate field survey cross-section data may also be required.
11. The County is implementing a storm water quality program as required by the SWRCB, which may modify or add to the requirements and guidelines presented elsewhere in this document. This can include ongoing monitoring of water quality of storm drain runoff, implementation of BMPs to reduce storm water quality impacts downstream or along adjacent properties. Attention is directed to the need to reduce any potential of vectors, mosquitoes, or standing water.
12. A Drainage Report is required for all developments in the County. It shall include a project description, project setting including discussions of existing and proposed conditions, any drainage issues related to the site, summary of the findings or conclusions, off-site hydrology, onsite hydrology, hydraulic calculations and a hydrology map.

Imperial Irrigation District

The IID is an irrigation district organized under the California Irrigation District Law, codified in Section 20500 et seq. of the California Water Code. Critical functions of IID include diversion and delivery of Colorado River water to the Imperial Valley, operation and maintenance of the drainage canals and facilities, including those in the project area, and generation and distribution of electricity. Several policy documents govern IID operations and are summarized below:

- The Law of the River and historical Colorado River decisions, agreements and contracts
- The Quantification Settlement Agreement and Transfer Agreements

- The Definite Plan, now referred to as the Systems Conservation Plan, which defines the rigorous agricultural water conservation practices being implemented by growers and IID to meet the Quantification Settlement Agreement commitments
- The Equitable Distribution Plan, which defines how IID will prevent overruns and stay within the cap on the Colorado River water rights
- Existing IID standards and guidelines for evaluation of new development and define IID's role as a responsible agency and wholesaler of water

Integrated Water Resources Management Plan

In relation to the project, IID maintains regulation over the drainage of water into their drains, including the design requirements of stormwater retention basins. IID requires that retention basins be sized to handle an entire rainfall event in case the IID system is at capacity. Additionally, IID requires that outlets to IID facilities be no larger than 12 inches in diameter and must contain a backflow prevention device (IID 2009).

3.10.3 Impacts and Mitigation Measures

Thresholds of Significance

Based on CEQA Guidelines Appendix G, project impacts related to hydrology/water quality are considered significant if any of the following occur:

- Violate any water quality standards or waste discharge requirements or otherwise substantially degrade groundwater water quality
- Substantially decrease groundwater supplies or interfere substantially with groundwater recharge such that the project may impede sustainable groundwater management of the basin
- Substantially alter the existing drainage pattern of the site or area, including through the alteration of the course of a stream or river or through the addition of impervious surfaces, in a manner which would:
 - Result in substantial erosion or siltation on- or off-site
 - Substantially increase the rate or amount of surface runoff in a manner which would result in flooding on- or offsite
 - Create or contribute runoff water which would exceed the capacity of existing or planned stormwater drainage systems or provide substantial additional sources of polluted runoff
 - Impede or redirect flood flows
- In flood hazard, tsunami, or seiche zones, risk release of pollutants due to project inundation
- Conflict with or obstruct implementation of a water quality control plan or sustainable groundwater management plan

Methodology

The drainage design will be conducted in accordance with the County of Imperial's design criteria, which establishes that 100 percent of the 100-year storm (3 inches of rain) will be stored on-site and



released into the IID drainage system using existing drainage connections. Specifically, the project site will be surrounded by a levee system designed to divert stormwater, including stormwater from a 100-year storm event. Diverted stormwater will be channeled to designated retention areas adjacent to the All-American Canal, thus protecting the solar array (see Appendix I, Drainage Plan).

Impact Analysis

Impact ***Would the project violate any water quality standards or waste discharge requirements or otherwise substantially degrade groundwater water quality?***
3.10-1

Construction

Construction of the proposed project would include site preparation, foundation construction, erection of major equipment and structures, installation of electrical systems, control systems, and startup/ testing. In addition, the construction of transmission lines, utility pole pads, conductors, and associated structures will be required.

During the construction phase, sedimentation and erosion can occur because of tracking from earthmoving equipment, erosion and subsequent runoff of soil, or improperly designed stockpiles. The utilization of proper erosion and sediment control BMPs is critical in preventing discharge to surface waters/drains. The project would employ proper SWPPP practices to minimize any discharges in order to meet the Best Available Technology/Best Conventional Technology standard set forth in the Construction General Permit.

Many different types of hazardous compounds will be used during the construction phase, with proper application, management, and containment being of high importance. Poorly managed construction materials can lead to the possibility for exposure of potential contaminants to precipitation. When this occurs, these visible and/or non-visible constituents become entrained in storm water runoff. This potential impact is considered a significant impact. With the implementation of Mitigation Measure HYD-1, impacts on surface water quality as attributable to the project would be reduced to a level less than significant. Prior to construction and grading activities, the project applicant is required to file an NOI with the SWRCB to comply with the General NPDES Construction Permit and prepare a SWPPP, which addresses the measures that would be included during construction or the project to minimize and control construction and post-construction runoff to the “maximum extent practicable.” In addition, NPDES permits require the implementation of BMPs that achieve a level of pollution control to the maximum extent practical. With the implementation of Mitigation Measure HYD-1, impacts on surface water quality as attributable to the project would be reduced to a level less than significant through the inclusion of focused BMPs for the protection of surface water resources. Monitoring and contingency response measures would be included to verify compliance with water quality objectives for all surface waters crossed during construction. In addition, given that site decommissioning would result in similar activities as identified for construction, these impacts could also occur in the future during site restoration activities. This is considered a less than significant impact after mitigation has been incorporated.

Operation

As runoff flows over developed surfaces, water can entrain a variety of potential pollutants including, but not limited to, oil and grease, pesticides, trace metals, and nutrients. These pollutants can become suspended in runoff and carried to receiving waters. These effects are commonly referred to as non-point source water quality impacts.

Long-term operation of the solar facility poses a limited threat to surface water quality after the completion of construction. The project would be subject to the County’s Grading Regulations as specified in Section 91010.02 of the Ordinance Code. However, since the project site is located in unincorporated Imperial County and not subject to a Municipal Separate Storm Sewer System or NPDES General Industrial Permit, there is no regulatory mechanism in place to address post-construction water quality concerns. Based on this consideration, the project has the potential to result in both direct and indirect water quality impacts that could be significant. Although the project site will be surrounded by a levee system designed to divert and retain stormwater, including stormwater from a 100-year storm event (see Appendix I, Drainage Plan), implementation of Mitigation Measure HYD-2 would require the project to incorporate post-construction source control and treatment control BMPs into the project’s final drainage plan. Implementation of the project-specific source control and treatment BMPs into the final drainage plan would result in a decreased potential for storm water pollution.

While source control and treatment control BMPs would be finalized during preparation of the final drainage plan, the following are examples of BMPs that could be utilized to reduce the potential for stormwater pollution.

Source Control BMPs. Source control BMPs (both structural and non-structural) means land use or site planning practices, or structures that aim to prevent urban runoff pollution by reducing the potential for contamination at the source of pollution. Source control BMPs minimize the contact between pollutants and urban runoff. Table 3.10-3 identifies examples of source control BMPs that could be implemented into the proposed project.

Table 3.10-3. Source Control Best Management Practices

Design Concept		Description
1	Design Trash Storage Areas to Reduce Pollution Introduction	Design outdoor trash storage areas so that run-on from adjoining areas cannot enter. Screen or wall trash enclosures to prevent the off-site transport of trash.
2	Activity Restrictions	Restrict activities that have the potential to create adverse impacts on water quality.
3	Non-storm Water Discharges	Provide educational materials on illegal dumping and spill response to employees.
4	Outdoor Loading and Unloading	Handle materials in a manner that prevents any storm water pollution.
5	Spill Prevention, Control, and Cleanup	Require a Spill Prevention, Control, and Countermeasure Plan, and a Hazardous Materials Business Plan in accordance with Federal and State requirements.
6	Education	Provide employees with materials for storm water pollution prevention in the form of brochures and other information in a format approved by the County of Imperial.
7	Integrated Pest Management	Reduce the need for pesticide use onsite by: <ul style="list-style-type: none"> • Keeping pests out of buildings using barriers, screens, and caulking • Eliminating pests through squashing, trapping, washing or pruning • Relying on natural enemies to eat pests • Using pesticides correctly as a last line of defense
8	Vehicle and Equipment Fueling, Cleaning, and Repair	Service all vehicles offsite whenever possible. If servicing is required onsite, it must be conducted in an area isolated from storm drain inlets or drainage ditch inlets. The area must be bermed and precluded from run on. Any spillage must be fully contained and captured and disposed of per County of Imperial Hazardous Waste requirements.



Table 3.10-3. Source Control Best Management Practices

Design Concept		Description
9	Waste Handling and Disposal	Dispose of materials in accordance with Imperial County Hazardous Material Management guidelines. Under no circumstances shall any waste or hazardous materials be stored outside without secondary containment.

Treatment Control BMPs. Treatment control BMPs include both short-term and long-term drainage solutions to ensure the proper sequencing of drainage facilities and treatment of runoff generated from project impervious surfaces prior to off-site discharge.

Mitigation Measure(s)

HYD-1 Prepare SWPPP and Implement BMPs Prior to Construction and Site Restoration. The project applicant or its contractor shall prepare a SWPPP specific to the project and be responsible for securing coverage under SWRCB’s NPDES stormwater permit for general construction activity (Order 2009-0009-DWQ). The SWPPP shall identify specific actions and BMPs relating to the prevention of stormwater pollution from project-related construction sources by identifying a practical sequence for site restoration, BMP implementation, contingency measures, responsible parties, and agency contacts. The SWPPP shall reflect localized surface hydrological conditions and shall be reviewed and approved by the appropriate agency prior to commencement of work and shall be made conditions of the contract with the contractor selected to build and decommission the project. The SWPPP shall incorporate control measures in the following categories:

- Soil stabilization and erosion control practices (e.g., hydroseeding, erosion control blankets, mulching)
- Sediment control practices (e.g., temporary sediment basins, fiber rolls)
- Temporary and post-construction on- and off-site runoff controls
- Special considerations and BMPs for water crossings and drainages
- Monitoring protocols for discharge(s) and receiving waters, with emphasis place on the following water quality objectives: dissolved oxygen, floating material, oil and grease, potential of hydrogen (pH), and turbidity
- Waste management, handling, and disposal control practices
- Corrective action and spill contingency measures
- Agency and responsible party contact information
- Training procedures that shall be used to ensure that workers are aware of permit requirements and proper installation methods for BMPs specified in the SWPPP

The SWPPP shall be prepared by a Qualified SWPPP Practitioner and/or Qualified SWPPP Developer with BMPs selected to achieve maximum pollutant removal and that represent the best available technology that is economically achievable. Emphasis for BMPs shall be placed on controlling discharges of oxygen-depleting

substances, floating material, oil and grease, acidic or caustic substances or compounds, and turbidity. BMPs for soil stabilization and erosion control practices and sediment control practices will also be required. Performance and effectiveness of these BMPs shall be determined either by visual means where applicable (i.e., observation of above-normal sediment release), or by actual water sampling in cases where verification of contaminant reduction or elimination, (inadvertent petroleum release) is required to determine adequacy of the measure.

HYD-2 Incorporate Post-Construction Runoff, Source Control, and Treatment Control BMPs into Final Project Drainage Plan. The project's Final Drainage Plan shall adhere to the County's Engineering Guidelines Manual, IID "Draft" Hydrology Manual, or other recognized source with approval by the County Engineer to control and manage the on- and off-site discharge of stormwater to existing drainage systems. The Final Drainage Plan shall provide both short- and long-term drainage solutions to ensure the proper sequencing of drainage facilities, and shall include source control and treatment BMPs to adequately treat collected runoff prior to discharge, as necessary.

Significance after Mitigation

With the implementation of Mitigation Measure HYD-1, impacts on hydrology and surface water quality as attributable to the proposed project would be reduced to a level less than significant through the inclusion of focused BMPs for the protection of surface water resources. Monitoring and contingency response measures would be included to verify compliance with water quality objectives for all surface waters crossed during construction.

With the implementation of Mitigation Measure HYD-2, potential hydrology and water quality impacts resulting from post-construction discharges during operation for the project would be reduced to a less than significant level. Implementation of Mitigation Measure HYD-2 would require the project to incorporate post-construction BMPs into the project's final drainage plan. The incorporation of source control and treatment BMPs into the final drainage plan would result in a decreased potential for storm water pollution.

Impact 3.10-2 *Would the project substantially decrease groundwater supplies or interfere substantially with groundwater recharge such that the project may impede sustainable groundwater management of the basin?*

Groundwater recharge in the area will not be significantly affected because the majority of the project site will feature a pervious landscape in both the existing and proposed conditions. Any runoff from solar panel washing would evaporate or percolate through the ground, as a majority of the surfaces in the solar field would remain pervious. Groundwater at/near the project site is not used for beneficial uses, such as municipal, domestic, or industrial supply. Construction and operational water needs would be provided by the All-American Canal in conformance with IID construction water acquisition requirements. Therefore, the proposed project would not substantially decrease groundwater supplies or interfere substantially with groundwater recharge such that the proposed project may impede sustainable groundwater management of the basin. As a result, no significant impacts on groundwater levels are expected.

Mitigation Measure(s)

No mitigation measures are required.



Impact 3.10-3 ***Would the project substantially alter the existing drainage pattern of the site or area, including through the alteration of the course of a stream or river or through the addition of impervious surfaces, in a manner which would:***

Result in substantial erosion or siltation on- or off-site?

Construction

Project construction activities, specifically grading and excavation, have the potential to temporarily alter the existing drainage pattern of the site such that soil erosion occurs. However, to the extent feasible, site preparation would be planned and designed to minimize the amount of earth movement. Compaction of the soil to support building and traffic loads as well as the PV module supports may be required and is dependent on final engineering design. During construction, erosion would be controlled in accordance with County standards which include preparation, review and approval of a grading plan by the County Engineer; implementation of a Dust Control Plan (Rule 801); and compliance with the NPDES General Construction Permit. Additionally, with implementation of Mitigation Measure HWQ-1, which requires the preparation of a project-specific SWPPP and construction BMPs, project construction would not substantially alter the existing drainage pattern of the site or area, including through the alteration of the course of a stream or river or through the addition of impervious surfaces, in a manner which would result in substantial on- or off-site erosion or siltation. This is considered a less than significant impact after mitigation has been incorporated.

Operation

Daily operations and routine maintenance (such as occasional PV panel washing) are not anticipated to increase erosion. Under existing conditions, runoff from adjacent agricultural land collects and is concentrated in the project site. Runoff within the project site generally flows south from the direction of the All-American Canal, toward the U.S.-Mexico border, and eventually drains into a playa at the south end of the site. While implementation of the project would include a new levee drainage system, the drainage system would be designed to continue to retain stormwater onsite. Additionally, during operational activities, soil erosion and sedimentation would be controlled in accordance with the NPDES General Construction Permit and project-specific SWPPP. The project site would remain largely impervious over the operational life of the project. The proposed project would result in less than significant impacts associated with the alteration of drainage patterns resulting in substantial erosion or siltation on- or off-site. This is considered a less than significant impact.

Mitigation Measure(s)

No additional mitigation measures beyond Mitigation Measure HYD-1 are required.

Significance after Mitigation

With the implementation of Mitigation Measures HYD-1, the potential hydrology and water quality impacts resulting from increased erosion during construction of the proposed project would be reduced to a level less than significant.

Impact ***Would the project substantially alter the existing drainage pattern of the site or area, including through the alteration of the course of a stream or river or through the addition of impervious surfaces, in a manner which would:***
3.10-4

Substantially increase the rate or amount of surface runoff in a manner which would result in flooding on- or offsite?

Construction

Project construction activities, specifically grading and excavation, have the potential to temporarily alter the existing drainage pattern of the site such that surface runoff increases in a manner which results in flooding on- or off-site. However, to the extent feasible, site preparation would be planned and designed to minimize the amount of earth movement. Compaction of the soil to support building and traffic loads as well as the PV module supports may be required and is dependent on final engineering design. During construction, erosion would be controlled in accordance with County standards which include preparation, review and approval of a grading plan by the County Engineer; implementation of a Dust Control Plan (Rule 801); and compliance with the NPDES General Construction Permit. Additionally, with implementation of Mitigation Measure HWQ-1, which requires the preparation of a project-specific SWPPP and construction BMPs, project construction would not substantially alter the existing drainage pattern of the site or area, including through the alteration of the course of a stream or river or through the addition of impervious surfaces, in a manner which would result in flooding on- or off-site. This is considered a less than significant impact after mitigation has been incorporated.

Operation

Existing drainage patterns would not be substantially altered during operation of the proposed project. Under existing conditions, runoff from adjacent agricultural land collects and is concentrated in the project site. Runoff within the project site generally flows south from the direction of the All-American Canal, toward the U.S.-Mexico border, and eventually drains into a playa at the south end of the site. While implementation of the project would include a new levee drainage system, the drainage system would be designed to continue to retain stormwater onsite. Additionally, the project will be designed to meet County of Imperial storage requirements for storm water runoff, which will result in an impoundment of runoff in excess of the anticipated volume of runoff to be generated by the 100-year storm event. Therefore, the proposed project would result in no significant impacts associated with the alteration of drainage patterns resulting in on- or off-site flooding. This is considered a less than significant impact after mitigation has been incorporated.

Mitigation Measure(s)

No additional mitigation measures beyond Mitigation Measure HYD-1 are required.

Significance after Mitigation

With the implementation of Mitigation Measures HYD-1 and HYD-2, the potential hydrology and water quality impacts resulting from increased surface runoff and associated flooding during construction and operation of the proposed project would be reduced to a level less than significant.



Impact ***Would the project substantially alter the existing drainage pattern of the site***
3.10-5 ***or area, including through the alteration of the course of a stream or river or***
 through the addition of impervious surfaces, in a manner which would:

Create or contribute runoff water which would exceed the capacity of existing or planned stormwater drainage systems or provide substantial additional sources of polluted runoff?

Construction

Project construction activities, specifically grading and excavation, have the potential to temporarily alter the existing drainage pattern of the site such that the capacity of existing or planned stormwater drainage systems is exceeded or substantial additional sources of polluted runoff are added to the stormwater drainage system. However, to the extent feasible, site preparation would be planned and designed to minimize the amount of earth movement. Compaction of the soil to support building and traffic loads as well as the PV module supports may be required and is dependent on final engineering design. During construction, erosion would be controlled in accordance with County standards which include preparation, review and approval of a grading plan by the County Engineer; implementation of a Dust Control Plan (Rule 801); and compliance with the NPDES General Construction Permit. Additionally, with implementation of Mitigation Measure HWQ-1, which requires the preparation of a project-specific SWPPP and construction BMPs, project construction would not substantially alter the existing drainage pattern of the site or area, including through the alteration of the course of a stream or river or through the addition of impervious surfaces, in a manner which would create or contribute runoff water which would exceed the capacity of existing or planned stormwater drainage systems or provide substantial additional sources of polluted runoff. This is considered a less than significant impact after mitigation has been incorporated.

Operation

The proposed project is not anticipated to generate a significant increase in the amount of runoff water from water use involving solar panel washing. Water will continue to percolate through the ground, as a majority of the surfaces on the project site would remain pervious. Existing drainage patterns would not be substantially altered because of the proposed project. Under existing conditions, runoff from adjacent agricultural land collects and is concentrated in the project site. Runoff within the project site generally flows south from the direction of the All-American Canal, toward the U.S.-Mexico border, and eventually drains into a playa at the south end of the site. While implementation of the project would include a new levee drainage system, the drainage system would be designed to continue to retain stormwater onsite. Additionally, with the implementation of Mitigation Measure HYD-2, potential water quality impacts resulting from post-construction discharges during operation of the project would be reduced to a less than significant level. Implementation of Mitigation Measure HYD-2 would require the project to incorporate post-construction BMPs into the project's final drainage plan. The incorporation of source control and treatment BMPs into the final drainage plan would result in a decreased potential for stormwater pollution. The proposed project would not create or contribute runoff water which would exceed the capacity of existing or planned stormwater drainage systems or provide substantial additional sources of polluted runoff. This is considered a less than significant impact after mitigation has been incorporated.

Mitigation Measure(s)

No additional mitigation measures beyond Mitigation Measure HYD-1 and HYD-2 are required.

Significance after Mitigation

With the implementation of Mitigation Measures HYD-1 and HYD-2, the potential hydrology and water quality impacts resulting from increased surface runoff and associated increases in polluted runoff entering the storm drain system during construction and operation of the proposed project would be reduced to a level less than significant.

Impact 3.10-6 *Would the project substantially alter the existing drainage pattern of the site or area, including through the alteration of the course of a stream or river or through the addition of impervious surfaces, in a manner which would:*

Impede or redirect flood flows?

According to the FEMA Flood Insurance Rate Map (Panel 06025C2125C) (FEMA 2008), the project site is within Zone X, which is an area determined to be outside of the 0.2 percent annual chance of a flood. Additionally, the project's drainage plan has been designed to meet County of Imperial storage requirements for storm water runoff, which will result in an impoundment of runoff in excess of the anticipated volume of runoff to be generated by the 100-year storm event. Therefore, the proposed project would not substantially alter the existing drainage pattern of the site or area, including through the alteration of the course of a stream or river or through the addition of impervious surfaces, in a manner which would impede or redirect flood flows, and no impact would occur.

Mitigation Measure(s)

No mitigation measures are required.

Impact 3.10-7 *In flood hazard, tsunami, or seiche zones, would the project risk release of pollutants due to project inundation?*

The project site is within Zone X, which is an area determined to be outside of the 0.2 percent annual chance of a flood. The project site is not located near any large bodies of water. The Salton Sea is located approximately 38 miles northwest of the project site. Because of the distance, the Salton Sea does not pose a particularly significant danger of inundation from seiche or tsunami as related to the project site. Furthermore, the project site is over 100 miles inland from the Pacific Ocean. In addition, the project site is relatively flat. Therefore, there is no potential for the project site to be inundated by seiches or tsunamis.

Mitigation Measure(s)

No mitigation measures are required.

Impact 3.10-8 *Would the project conflict with or obstruct implementation of a water quality control plan or sustainable groundwater management plan?*

As described under Impact 3.10-1 above, with the implementation of Mitigation Measure HYD-1, impacts on surface water quality as attributable to the proposed project would be reduced to a level less than significant through the inclusion of focused BMPs for the protection of surface water

resources. Implementation of Mitigation Measure HYD-2 would require the project to incorporate post-construction BMPs into the project's final drainage plan. The use of source control, site design, and treatment BMPs would result in a decrease potential for storm water pollution. Therefore, the proposed project would not pose a significant threat to local surface water features or shallow groundwater resources. Implementation of Mitigation Measures HYD-1 and HYD-2 would reduce impacts to a level less than significant.

Mitigation Measure(s)

No additional mitigation measures beyond Mitigation Measures HYD-1 and HYD-2 are required.

Significance after Mitigation

With the implementation of Mitigation Measures HYD-1 and HYD-2, the potential hydrology and water quality impacts resulting from conflicts with a water quality control plan or groundwater management plan during construction and operation of the proposed project would be reduced to a level less than significant.

3.10.4 Decommissioning/Restoration and Residual Impacts

Decommissioning/Restoration

Decommissioning and restoration activities would result in similar impacts on hydrology and water quality as would occur during construction of the proposed project. The primary water quality issue associated with decommissioning/restoration would be potential impacts on surface water quality, as the decommissioning activities would be similar to construction activities and would be considered a significant impact. However, during decommissioning, soil erosion would be controlled in accordance with NPDES General Construction Permit(s) and project-specific SWPPP. Compliance with requirements and best available control technologies in place at the time of decommissioning are anticipated to be similar to, or more stringent than, those currently required. Compliance with all applicable water quality regulations would reduce the project's impacts during decommissioning to a level less than significant. Impacts on other water resource issues, including alteration of drainage patterns, contributing to off-site flooding, impacts on groundwater recharge and supply, would be less than significant. There would be no impact associated with inundation from flooding, tsunamis, or seiche zones.

Residual

With implementation of the mitigation measures listed above, implementation of the proposed project would not result in any residual significant impacts related to increased risk of flooding from stormwater runoff, from water quality effects from long-term urban runoff, or from short-term alteration of drainages and associated surface water quality and sedimentation. With the implementation of the required mitigation measures during construction and decommissioning of the project, water quality impacts would be minimized to a level less than significant. Based on these circumstances, the proposed project would not result in any residential significant and unmitigable adverse impacts on surface water hydrology and water quality.

This page is intentionally blank.

3.11 Land Use Planning

This section provides information regarding current land use, land use designations, and land use policies within, and in the vicinity of, the project site. Section 15125(d) of the CEQA Guidelines states that “[t]he EIR shall discuss any inconsistencies between the project and applicable general plans and regional plans.” This section fulfills this requirement for the project. In this context, this section reviews the land use assumptions, designations, and policies of the County General Plan and other applicable federal, state, and local requirements, which governs land use within the project area and evaluates the project’s potential to conflict and/or adherence with policies adopted for the purpose of avoiding or mitigating significant environmental effects. Where appropriate, mitigation is applied and the resulting level of impact identified.

3.11.1 Existing Conditions

The project site is located within an unincorporated area of Imperial County, approximately 10 miles east of the City of Calexico. The 450-acre project site is located on two contiguous privately-owned parcels (APNs 059-300-015 and 059-300-017). The irregular shaped project site is bound by undeveloped land, portions of which have been disturbed associated with previous agricultural-related activities to the west and east, the All-American Canal running southwest on the northern border of the project site, and the U.S./Mexico international border to the south. The project site is currently characterized by flat and undeveloped land, portions of which have been disturbed associated with previous agricultural-related activities. The existing IID 92 kV “P” Line is located immediately north of the All-American Canal.

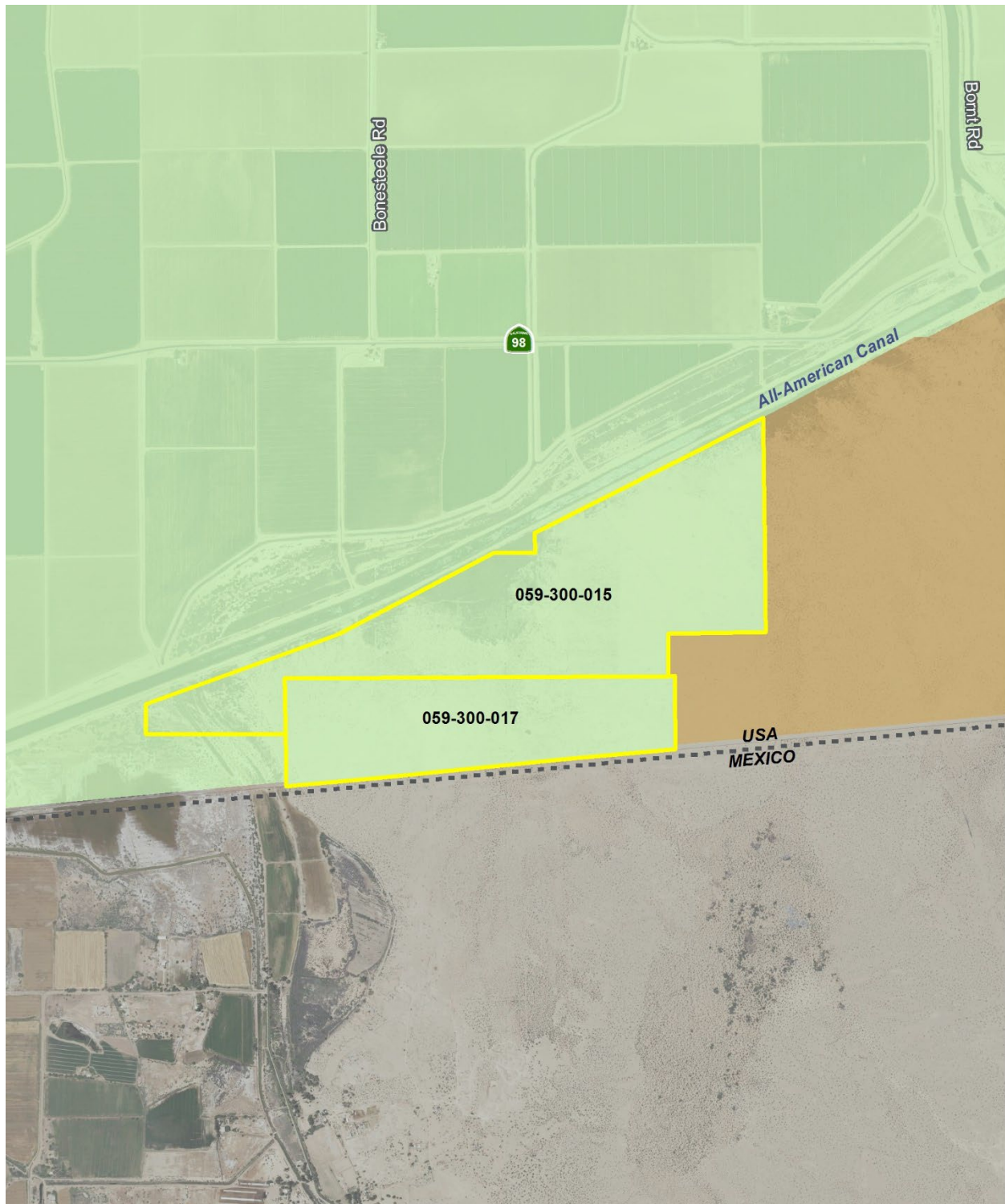
As shown on Figure 3.11-1, the project site is designated as Agriculture under the County’s General Plan. As shown on Figure 3.11-2, the project site is currently zoned Heavy Agriculture with a RE Zone Overlay (A-3-RE). Land uses surrounding the project site are designated by the General Plan as Agriculture to the north and west, and Recreation to the east.

The County adopted the RE and Transmission Element, which includes a RE Zone (RE Overlay Map). The RE Overlay Zone is concentrated in areas determined to be the most suitable for the development of RE facilities while minimizing the impact to other established uses. As shown on Figure 3.11-2, the entire project site is located within the RE Overlay Zone.


The project site is located in a sparsely populated portion of Imperial County. There are no established residential communities located within or in the vicinity of the project site. The nearest established residential community is in Calexico.

The nearest airports to the project site are the Calexico International Airport located approximately 10 miles west of the project site and the Holtville Airport located approximately 10 miles north of the project site.

Figure 3.11-1. General Plan Land Use Designations



Legend

 Project Site (Assessor Parcel No. 059-300-015 and 059-300-017)

General Plan Land Use

-  Agriculture
-  Recreation

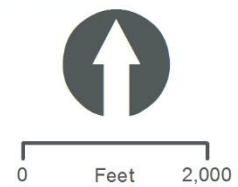
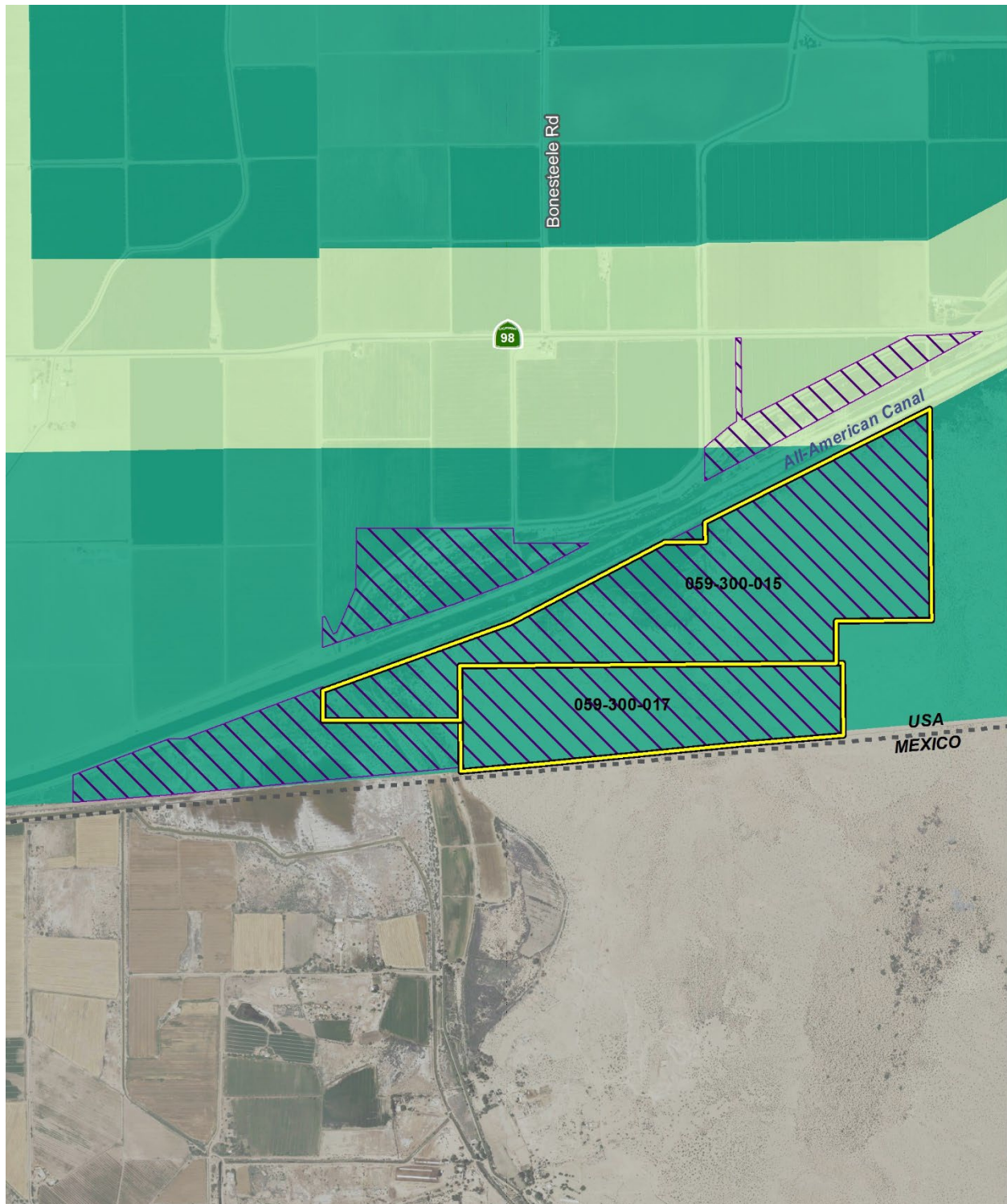


Figure 3.11-2. Zoning Designations



Legend

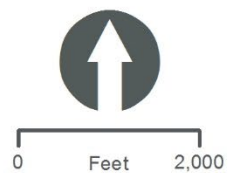
Project Site (Assessor Parcel No. 059-300-015 and 059-300-017)

Renewable Energy Overlay

Zoning

A-2 - General Agricultural Zone

A-3 - Heavy Agriculture



3.11.2 Regulatory Setting

This section identifies and summarizes laws, policies, and regulations that are applicable to the project.

State

State Planning and Zoning Laws

California Government Code Section 65300 et seq. establishes the obligation of cities and counties to adopt and implement general plans. The general plan is a comprehensive, long-term, and general document that describes plans for the physical development of a city or county and of any land outside its boundaries that, in the city's or county's judgment, bears relation to its planning.

The general plan addresses a broad range of topics, including, at a minimum, land use, circulation, housing, conservation, open space, noise, and safety. In addressing these topics, the general plan identifies the goals, objectives, policies, principles, standards, and plan proposals that support the city's or county's vision for the area. The general plan is a long-range document that typically addresses the physical character of an area over a 20-year period or more.

The State Zoning Law (California Government Code Section 65800 et seq.) establishes that zoning ordinances, which are laws that define allowable land uses within a specific zone district, are required to be consistent with the general plan and any applicable specific plans.

Regional

Southern California Association of Governments – 2020-2045 Regional Transportation Plan/Sustainable Communities Strategy (Connect SoCal)

SCAG is the designated metropolitan planning organization for Los Angeles, Ventura, Orange, San Bernardino, Riverside, and Imperial Counties. CEQA requires that regional agencies like SCAG review projects and plans throughout its jurisdiction. SCAG, as the region's "Clearinghouse," collects information on projects of varying size and scope to provide a central point to monitor regional activity. SCAG has the responsibility of reviewing dozens of projects, plans, and programs every month. Projects and plans that are regionally significant must demonstrate to SCAG their consistency with a range of adopted regional plans and policies.

On September 3, 2020, SCAG adopted the 2020-2045 RTP/SCS (Connect SoCal). The 2020-2045 RTP/SCS (Connect SoCal) includes a strong commitment to reduce emissions from transportation sources to comply with Senate Bill 375, improve public health, and meet the NAAQS as set forth by the federal CAA. The following goals from the 2020-2045 RTP/SCS (Connect SoCal) are considered applicable to the proposed project:

- Goal 5: Reduce GHG emissions and improve air quality
- Goal 10: Promote conservation of natural and agricultural lands and restoration of habitats

Local

County of Imperial General Plan

The purpose of the County's General Plan (as amended through 2008) is to direct growth, particularly urban development, to areas where public infrastructure exists or can be provided, where public health and safety hazards are limited, and where impacts to the County's abundant natural, cultural, and



economic resources can be avoided. The following 10 elements comprise the County’s General Plan: Land Use; Housing; Circulation and Scenic Highways; Noise; Seismic and Public Safety; Conservation and Open Space; Agricultural; RE and Transmission Element; Water; and Parks and Recreation. Together, these elements satisfy the seven mandatory general plan elements as established in the California Government Code. Goals, objectives, and implementing policies and actions programs have been established for each of the elements.

Imperial County received funding from the California Energy Commission RE and Conservation Planning Grant to amend and update the County’s General Plan in order to facilitate future development of RE projects. The Geothermal/Alternative Energy and Transmission Element was last updated in 2006. Since then there have been numerous renewable projects proposed, approved, and constructed within Imperial County as a result of California’s move to reduce GHG emissions, develop alternative fuel sources and implement its Renewable Portfolio Standard. The County prepared an update to the Geothermal/Alternative Energy and Transmission Element of its General Plan, called the RE and Transmission Element. This Element is designed to provide guidance and approaches with respect to the future siting of RE projects and electrical transmission lines in the County. The County adopted this element in 2016, which has been amended several times to incorporate additional overlay zones.

The RE and Transmission Element includes a RE Zone (RE Overlay Map). The County Land Use Ordinance, Division 17, includes the RE Overlay Zone, which authorizes the development and operation of RE projects, with an approved CUP. The RE Overlay Zone is concentrated in areas determined to be the most suitable for the development of RE facilities while minimizing the impact to other established uses. As shown on Figure 3.11-2, the entire project site is located within the RE Overlay Zone.

An analysis of the project’s consistency with the General Plan goals and objectives relevant to the project is provided in Table 3.11-1. While this EIR analyzes the project’s consistency with the General Plan pursuant to CEQA Guidelines Section 15125(d), the Imperial County Planning Commission and Board of Supervisors retain final authority for the determination of the project’s consistency with the General Plan.

Table 3.11-1. Project Consistency with Applicable General Plan Policies

Applicable Policies	Consistency Determination	Analysis
Land Use Element		
Public Facilities. Objective 8.7: Ensure the development, improvement, timing, and location of community sewer, water, and drainage facilities will meet the needs of existing communities and new developing areas.	Consistent	The proposed project includes the necessary supporting infrastructure and would not require new community-based infrastructure. The proposed project would be required to construct supporting drainage infrastructure on-site consistent with County requirements and mitigation measures prescribed in Section 3.10 Hydrology/Water Quality of the EIR. Once the proposed project is operational, a limited amount of water would be required for solar panel washing and fire protection. The proposed project would not require an operations and maintenance building. Therefore, no septic system would be required for the proposed project.

Table 3.11-1. Project Consistency with Applicable General Plan Policies

Applicable Policies	Consistency Determination	Analysis
Public Facilities. Objective 8.8: Ensure that the siting of future facilities for the transmission of electricity, gas, and telecommunications is compatible with the environment and County regulation.	Consistent	The County Land Use Ordinance, Division 17, includes the RE Overlay Zone, which authorizes the development and operation of RE projects with an approved CUP. The RE Overlay Zone is concentrated in areas determined to be the most suitable for the development of RE facilities while minimizing the impact to other established uses. As shown on Figure 3.11-2, the project site is located within the RE Overlay Zone. Therefore, the proposed project would be sited in a suitable location for the transmission of electricity.
Public Facilities. Objective 8.9: Require necessary public utility rights-of-way when appropriate.	Consistent	The proposed project would include the dedication of ROW, if necessary, to facilitate the placement of electrical distribution and transmission infrastructure.
Protection of Environmental Resources. Objective 9.6: Incorporate the strategies of the Imperial County AQAP in land use planning decisions and as amended.	Consistent	Dust suppression will be implemented in accordance with a dust control plan approved by the ICAPCD. Section 3.4, Air Quality, discusses the project's consistency with the AQAP in more detail.
<i>Circulation and Scenic Highways Element</i>		
Safe, Convenient, and Efficient Transportation System. Objective 1.1: Maintain and improve the existing road and highway network, while providing for future expansion and improvement based on travel demand and the development of alternative travel modes.	Consistent	The proposed project would include limited operational vehicle trips and would not be expected to reduce the current LOS at affected intersections, roadway segments, and highways. The proposed project does not propose residential or commercial development and therefore would not require new forms of alternative transportation to minimize impacts to existing roadways.
Safe, Convenient, and Efficient Transportation System. Objective 1.2: Require a traffic analysis for any new development which may have a significant impact on County roads.	Consistent	As described in Section 3.13, Transportation, a traffic study was prepared for the project and determined that the proposed project would have a less than significant impact on the circulation network. Once construction is completed, the project would be remotely operated, controlled and monitored and with no requirement for daily on-site employees. The project would include limited operational vehicle trips and would not reduce the current level of service at affected intersections, roadway segments, and highways.



Table 3.11-1. Project Consistency with Applicable General Plan Policies

Applicable Policies	Consistency Determination	Analysis
Noise Element		
Noise Environment. Objective 1.3: Control noise levels at the source where feasible.	Consistent	As discussed in Section 3.12, Noise and Vibration, no individual or cumulative pieces of construction equipment would exceed the 75 dBA Imperial County construction noise standard during any phase of construction at the nearest noise-sensitive receptor. Project operational noise would not exceed County daytime or nighttime standards.
Project/Land Use Planning. Goal 2: Review Proposed Actions for noise impacts and require design which will provide acceptable indoor and outdoor noise environments.	Consistent	The project would be required to comply with the County's noise standards during both construction and operation. As discussed in Section 3.12, Noise and Vibration, no individual or cumulative pieces of construction equipment would exceed the 75 dBA Imperial County construction noise standard during any phase of construction at the nearest noise-sensitive receptor. Project operational noise would not exceed County daytime or nighttime standards.
Conservation and Open Space Element		
Conservation of Environmental Resources for Future Generations Goal 1: Environmental resources shall be conserved for future generations by minimizing environmental impacts in all land use decisions and educating the public on their value.	Consistent	<p>The project site would be converted from undeveloped land to a solar energy facility. The proposed project is a response to the state's need for renewable energy to meet its Renewable Portfolio Standard, and while it would increase the availability of renewable energy, it would also replace existing sources of non-renewable energy.</p> <p>The power generated by the proposed project would be added to the state's electricity grid with the intent that it would displace fossil fueled power plants and their associated environmental impacts (i.e., air quality and GHG emissions). The proposed project would ensure future generations have access to a broad array of renewable energy sources, providing the public with alternative choices to fossil fuels.</p>
Conservation of Biological Resources. Goal 2: The County will integrate programmatic strategies for the conservation of critical habitats to manage their integrity, function, productivity, and long-term viability.	Consistent	A biological resources survey was conducted for the project site. As discussed in Section 3.5, Biological Resources, there are potentially significant biological resources located within the project site. However, with the implementation of Mitigation Measures BIO-1 through BIO-7 these impacts would be reduced to a level less than significant. The project site is not designated or otherwise identified as critical habitat for any species.

Table 3.11-1. Project Consistency with Applicable General Plan Policies

Applicable Policies	Consistency Determination	Analysis
<p>Preservation of Cultural Resources. Objective 3.1: Protect and preserve sites of archaeological, ecological, historical, and scientific value, and/or cultural significance.</p>	<p>Consistent</p>	<p>A cultural resources report was prepared for the project site. As discussed in Section 3.6, Cultural Resources, the proposed project has the potential to impact historical resources, and encounter undocumented archaeological resources and human remains. Mitigation Measures CR-1 and CR-4 have been identified to reduce potential impacts to a level less than significant.</p>
<p>Conservation of Water Resources. Objective 6.1: Ensure the use and protection of all the rivers, waterways, and groundwater sources in the County for use by future generations.</p>	<p>Consistent</p>	<p>As discussed in Section 3.10, Hydrology/Water Quality, the project will prepare a site-specific drainage plan and water quality management plan to minimize adverse effects to local water resources; as well as coordinate with the IID for water consumption during construction and operation of the project.</p>
<p>Conservation of Energy Sources. Objective 6.2: Encourage the utilization of alternative passive and renewable energy resources.</p>	<p>Consistent</p>	<p>The proposed project entails the construction and operation of a solar energy facility, which is considered an alternative source of energy.</p>
<p>Conservation of Energy Sources. Objective 6.6: Encourage compatibility with National and State energy goals and city and community general plans.</p>	<p>Consistent</p>	<p>The proposed project is consistent with California Public Utilities Code § 399.11 et seq., “Increasing the Diversity, Reliability, Public Health and Environmental Benefits of the Energy Mix.” California’s electric utility companies are required to procure 50 percent of their electricity from eligible renewable energy resources by 2030. Additionally, the proposed project would contribute toward the state’s need for RE to meet the goals of its Renewable Portfolio Standard.</p>
<p>Protection of Air Quality and Addressing Climate Change. Goal 7: The County shall actively seek to improve the quality of air in the region.</p>	<p>Consistent</p>	<p>The proposed project would be required to comply with all applicable ICAPCD rules and requirements during construction and operation to reduce air emissions. Overall, the proposed project would improve air quality and reduce GHG emissions by reducing the amount of emissions that would be generated in association with electricity production from a fossil fuel burning facility. Therefore, the proposed project is consistent with this goal.</p>
<p>Protection of Air Quality and Addressing Climate Change. Objective 7.1: Ensure that all project and facilities comply with current Federal, State and local requirements for attainment of air quality objectives.</p>	<p>Consistent</p>	<p>The proposed project would comply with current federal and State requirements for attainment for air quality objectives through conformance with all applicable ICAPCD rules and requirements to reduce fugitive dust and emissions. Further, the proposed project would comply with the ICAPCD Air Quality CEQA Handbook’s Mandatory Standard, Discretionary and Enhanced Air Quality Measures (Mitigation Measure AQ-1). Therefore, the proposed project is consistent with this objective.</p>



Table 3.11-1. Project Consistency with Applicable General Plan Policies

Applicable Policies	Consistency Determination	Analysis
Protection of Air Quality and Addressing Climate Change. Objective 7.2: Develop management strategies to mitigate fugitive dust. Cooperate with all federal and state agencies in the effort to attain air quality objectives.	Consistent	The Applicant would cooperate with all federal and State agencies in the effort to attain air quality objectives through compliance with the ICAPCD Air Quality CEQA Handbook’s Mandatory Standard, Discretionary and Enhanced Air Quality Measures (Mitigation Measure AQ-1). Therefore, the proposed project is consistent with this objective.
Protection of Open Space and Recreational Opportunities. Objective 8.2: Focus all new renewable energy development within adopted Renewable Energy Overlay Zones.	Consistent	As shown on Figure 3.11-2, the project site is located entirely within the RE Overlay Zone.
<i>RE and Transmission Element</i>		
Objective 1.4: Analyze potential impacts on agricultural, natural, and cultural resources, as appropriate.	Consistent	This EIR has been prepared to meet the requirements of CEQA for purposes of evaluating the potential environmental impacts associated with the proposed project, which includes analysis on applicable environmental topics that analyze impacts on agricultural, natural, and cultural resources.
Objective 1.5: Require appropriate mitigation and monitoring for environmental issues associated with developing RE facilities.	Consistent	A biological resources report has been prepared for the project, which is summarized in Section 3.5, Biological Resources, along with potential impacts attributable to the proposed project. With incorporation of Mitigation Measures BIO-1 through BIO-7 identified in Section 3.5, Biological Resources, less than significant impacts would result.
Objective 1.6: Encourage the efficient use of water resources required in the operation of renewable energy generation facilities.	Consistent	As previously mentioned, water consumption during construction would be used primarily for dust control, and obtained from local IID irrigation canals or laterals in conformance with IID construction water acquisition requirements. The project applicant will also coordinate with IID to purchase water needed for maintenance activities (i.e., PV module washing) to ensure efficient use of water resources.
Objective 1.7: Assure that development of RE facilities and transmission lines comply with ICAPCD’s regulations and mitigation measures.	Consistent	Dust suppression will be implemented including the use of water and soil binders during construction. Section 3.4, Air Quality, discusses the project’s compliance with ICAPCD’s regulations in more detail.

Table 3.11-1. Project Consistency with Applicable General Plan Policies

Applicable Policies	Consistency Determination	Analysis
<p>Objective 2.1: To the extent practicable, maximize utilization of IID’s transmission capacity in existing easements or rights-of-way. Encourage the location of all major transmission lines within designated corridors easements, and rights-of-way.</p>	<p>Consistent</p>	<p>The proposed project involves the construction and operation of new RE infrastructure that would interconnect with existing IID transmission infrastructure thereby maximizing the use of existing facilities located within existing easements and/or ROW. As discussed in Chapter 2, Project Description, the power produced by the proposed project would be conveyed to the local power grid via an on-site 92 kV substation, which will be tied directly to IID’s existing 92 kV “P” transmission line.</p>
<p><i>Seismic and Public Safety Element</i></p>		
<p>Land Use Planning and Public Safety. Goal 1: Include public health and safety considerations in land use planning.</p>	<p>Consistent</p>	<p>Division 5 of the County Land Use Ordinance has established procedures and standards for development within earthquake fault zones. Per County regulations, construction of buildings intended for human occupancy which are located across the trace of an active fault are prohibited. An exception exists when such buildings located near the fault or within a designated Special Studies Zone are demonstrated through a geotechnical analysis and report not to expose a person to undue hazard created by the construction.</p> <p>Since the project site is located in a seismically active area, the project is required to be designed in accordance with the CBC for near source factors derived from a design basis earthquake based on a peak ground acceleration of 0.50 gravity. It should be noted that, the project would be remotely operated and would not require any habitable structures on site. In considering these factors in conjunction with mitigation requirements outlined in the impact analysis, the risks associated with seismic hazards would be minimized.</p> <p>A preliminary geotechnical report has been prepared for the proposed project. The preliminary geotechnical report has been referenced in this environmental document. Additionally, a design-level geotechnical investigation would be conducted to evaluate the potential for site specific hazards associated with seismic activity.</p>
<p>Land Use Planning and Public Safety. Objective 1.1: Ensure that data on geological hazards is incorporated into the land use review process, and future development process.</p>		
<p>Land Use Planning and Public Safety. Objective 1.3: Regulate development adjacent to or near all mineral deposits and geothermal operations.</p>		
<p>Land Use Planning and Public Safety. Objective 1.4: Require, where possessing the authority, that avoidable seismic risks be avoided; and that measures, commensurate with risks, be taken to reduce injury, loss of life, destruction of property, and disruption of service.</p>		
<p>Land Use Planning and Public Safety. Objective 1.7: Require developers to provide information related to geologic and seismic hazards when siting a proposed project.</p>		
<p>Emergency Preparedness. Goal 2: Minimize potential hazards to public health, safety, and welfare and prevent the loss of life and damage to health and property resulting from both natural and human-related phenomena.</p>		
<p>Emergency Preparedness. Objective 2.2: Reduce risk and damage due to seismic hazards by appropriate regulation.</p>		



Table 3.11-1. Project Consistency with Applicable General Plan Policies

Applicable Policies	Consistency Determination	Analysis
Emergency Preparedness. Objective 2.5: Minimize injury, loss of life, and damage to property by implementing all state codes where applicable.		
Emergency Preparedness. Objective 2.8: Prevent and reduce death, injuries, property damage, and economic and social dislocation resulting from natural hazards including flooding, land subsidence, earthquakes, other geologic phenomena, levee or dam failure, urban and wildland fires and building collapse by appropriate planning and emergency measures.		
Water Element		
Protection of Water Resources from Hazardous Materials. Program: The County of Imperial shall make every reasonable effort to limit or preclude the contamination or degradation of all groundwater and surface water resources in the County.	Consistent	Mitigation measures will require that the applicant of the proposed project prepare a site-specific drainage plan and water quality management plan to minimize adverse effects to local water resources.
Protection of Water Resources from Hazardous Materials. Program: All development proposals brought before the County of Imperial shall be reviewed for potential adverse effects on water quality and quantity, and shall be required to implement appropriate mitigation measures for any significant impacts.	Consistent	See previous response for Water Element above.
Housing Element		
Not Applicable. The proposed project is a solar energy project and does not include the development of housing.		

Source: Imperial County General Plan, as amended

Notes:

AQAP=air quality attainment plan; CBC=California Building Code; CUP=conditional use permit; EIR=environmental impact report; GHG=greenhouse gas; ICAPCD=Imperial County Air Pollution Control District; IID=Imperial Control District; LOS=level of service; RE=renewable energy; ROW=right-of-way

County of Imperial Land Use Ordinance

The County’s Land Use Ordinance provides the physical land use planning criteria for development within the jurisdiction of the County. The Land Use Ordinance identifies the permitted and conditional uses within a zoning designation. Uses identified as conditionally permitted require a CUP, which is subject to the discretionary approval of the County Board of Supervisors per a recommendation by the County Planning Commission.

PERMITTED AND CONDITIONAL USES

A-3 Zoning. As shown on Figure 3.11-2, the project site is zoned Heavy Agriculture with a Renewable Energy Zone Overlay (A-3-RE). Pursuant to Title 9, Division 5, Chapter 9, the purpose of the A-3 zoning designation is to “designate areas that are suitable for agricultural land uses; to prevent the encroachment of incompatible uses onto and within agricultural lands; and to prohibit the premature conversion of such lands to non-agricultural uses. It is a land use that is to promote the heaviest of agricultural uses in the most suitable land areas of the county. Uses in the A-3 zoning designation are limited primarily to agricultural related uses and agricultural activities that are compatible with agricultural uses” (County of Imperial 2020).

Uses in the A-3 zoning designation are limited primarily to agricultural-related uses and agricultural activities that are compatible with agricultural uses. Pursuant to Title 9, Division 5, Chapter 9, the following uses are permitted in the A-3 zone subject to approval of a CUP from Imperial County:

i) Battery Storage Facility (must be connected to an existing electrical power generation plant such as solar, geothermal, wind, natural gas, or other renewable energy generator, as an accessory unit to said power plant).

oo) Major facilities relating to the generation and transmission of electrical energy, provided such facilities are not under State or Federal law, to [be] approved exclusively by an agency, or agencies of the State or Federal government, and provided such facilities shall be approved subsequent to coordination review of the Imperial Irrigation District for electrical matters, meeting the requirements in Division 17.

zz) Solar energy plants meeting the requirements in Division 17.

Height Limit. Section 90509.07 of the Land Use Ordinance limits the height of all non-residential structures and specifically states in Section 90509.07 (C) that, “Non-Residential structures and commercial communication towers shall not exceed one hundred twenty (120) feet in height, and as may be required by the airport land use compatibility plan (ALUCP).” The height of the proposed gen-tie transmission structures would be 60 feet.

RE Resources. According to Title 9, Division 17 of the Land use Ordinance, the purpose of the RE Resources regulations are to “facilitate the beneficial use of renewable energy resources for the general welfare of the people of Imperial County and the State of California; to protect renewable energy resources from wasteful or detrimental uses; and to protect people, property, and the environment from detriments that might result from the improper use of renewable energy resources” (County of Imperial 2017).

Title 9, Division 17 of the Land Use Ordinance includes the RE Overlay Zone, which authorizes the development and operation of renewable energy projects, with an approved CUP. Uses that are conditionally permitted require and require a CUP are subject to the discretionary approval of the County Board of Supervisors (Board) per a recommendation by the County Planning Commission.

Imperial County Airport Land Use Compatibility Plan

The Imperial County Airport Land Use Compatibility Plan (ALUCP) provides the criteria and policies used by the Imperial County Airport Land Use Commission to assess compatibility between the principal airports in Imperial County and proposed land use development in the areas surrounding the airports. The ALUCP emphasizes review of local general and specific plans, zoning ordinances, and other land use documents covering broad geographic areas.

The nearest airports to the project site are the Calexico International Airport located approximately 10 miles west of the project site and Holtville Airport located approximately 10 miles north of the project site. According to Figure 3B (Compatibility Map – Calexico International Airport) and Figure 3D (Compatibility Map – Holtville Airport) of the ALUCP, no portion of the project site is located within the Calexico International Airport or Holtville Airport’s land use compatibility zones (County of Imperial 1996).

3.11.3 Impacts and Mitigation Measures

Thresholds of Significance

Based on CEQA Guidelines Appendix G, project impacts related to land use/planning are considered significant if any of the following occur:

- Physically divide an established community
- Cause a significant environmental impact due to a conflict with any land use plan, policy, or regulation adopted for the purpose of avoiding or mitigating an environmental effect

Methodology

The project’s consistency with applicable federal, state, and local land uses plans and policies was evaluated in order to analyze land use consistency and land use impacts. The approach employed included:

- Review of the proposed project relative to the land use assumptions, policies, and designations of the Imperial County General Plan and applicable land use plans, policies, and regulations.
- Identification of potential conflicts between the proposed land uses and existing or proposed land uses in the vicinity.

In some instances, the land use for the project poses potential physical environmental consequences, such as traffic. In these cases, the consequences are discussed in the specific section of this EIR that focuses on that issue. The conceptual site plan for the project was also used to evaluate potential impacts.

Impact Analysis

Impact **Would the project physically divide an established community?**
3.11-1

The project site is located in a sparsely populated portion of Imperial County. There are no established residential communities located within or in the vicinity of the project site. The nearest established residential community is located approximately 10 miles west of the project site in Calexico. Therefore, implementation of the proposed project would not divide an established community and no impact would occur.

Mitigation Measure(s)

No mitigation measures are required.

Impact 3.11-2 ***Would the project cause a significant environmental impact due to a conflict with any land use plan, policy, or regulation adopted for the purpose of avoiding or mitigating an environmental effect?***

The project's consistency with applicable land use plans, policies, and regulations is evaluated below.

SCAG 2020-2045 RTP/SCS (Connect SoCal)

As noted above, the 2020-2045 RTP/SCS (Connect SoCal) (SCAG 2020) identifies two goals which include reducing GHG emissions to improve air quality (Goal 5), and to promote conservation of natural and agricultural lands (Goal 10).

The 2020-2045 RTP/SCS (Connect SoCal), identifies strategies to support the goal of reducing regional GHG and improve air quality. Strategies include leveraging technological innovations including incorporating solar energy, hydrogen fuel cell power storage, and power generation. Once in operation, the proposed project would contribute to SCAG's goal in reducing GHG emissions and improving air quality.

The 2020-2045 RTP/SCS (Connect SoCal) also discusses the decline of agricultural land as an issue for the economy. The proposed project would temporarily convert Farmland of Local Importance to non-agricultural uses. However, as a condition of project approval (CUP condition), the project applicant or its successor in interest will be responsible for implementing a reclamation plan when the project is decommissioned at the end of its lifespan. The reclamation plan includes the removal, recycling, and/or disposal of all solar arrays, inverters, transformers, and other structures on the project site, as well as restoration of the site to its pre-project condition. Therefore, the proposed project would not permanently convert Farmland of Local Importance to non-agricultural uses. Therefore, no impacts due to a conflict with the 2020-2045 RTP/SCS (Connect SoCal) would occur.

County of Imperial General Plan

The County's General Plan applies to the solar energy facility and supporting infrastructure portions associated with the project. An analysis of the project's consistency with the General Plan goals and objectives relevant to the project is provided in Table 3.11-1. As shown in Table 3.11-1, the proposed project would generally be consistent with the goals and objectives of the General Plan. No amendment to the General Plan for a zone change would be required because the project site is entirely within the RE Overlay Zone. Therefore, no impacts due to a conflict with the General Plan would occur.

County of Imperial Land Use Ordinance

Development of the solar energy facility and supporting is subject to the County's zoning ordinance. The solar energy facility is located on two privately-owned legal parcels zoned A-3-RE. Pursuant to Title 9, Division 5, Chapter 9, the following uses are permitted in the A-3 zone subject to approval of a CUP from Imperial County:

- i) Battery Storage Facility (must be connected to an existing electrical power generation plant such as solar, geothermal, wind, natural gas, or other renewable energy generator, as an accessory unit to said power plant).*
- oo) Major facilities relating to the generation and transmission of electrical energy, provided such facilities are not under State or Federal law, to [be] approved exclusively by an agency,*

or agencies of the State or Federal government, and provided such facilities shall be approved subsequent to coordination review of the Imperial Irrigation District for electrical matters, meeting the requirements in Division 17.

zz) Solar energy plants meeting the requirements in Division 17.

Therefore, with approval of a CUP for the project, the proposed project would not conflict with the County's zoning ordinance.

Title 9, Division 17 of the Land use Ordinance, includes the RE Overlay Zone, which authorizes the development and operation of renewable energy projects, with an approved CUP. Therefore, the proposed project qualifies as a permitted use with the approval of a CUP by the County to allow for the construction and operation of the proposed solar energy facility. With approval of a CUP, the proposed project would not conflict with the County's zoning ordinance. No impacts due to a conflict with the County of Imperial Land Use Ordinance(s) would occur.

Imperial County Airport Land Use Compatibility Plan

As discussed above in Section 3.11.2, the nearest airports to the project site are the Calexico International Airport located approximately 10 miles west of the project site and Holtville Airport located approximately 10 miles north of the project site. According to Figure 3B (Compatibility Map – Calexico International Airport) and Figure 3D (Compatibility Map – Holtville Airport) of the ALUCP, no portion of the project site is located within the Calexico International Airport or Holtville Airport's land use compatibility zones (ALUC 1996). Therefore, the proposed project would not conflict with the Imperial County ALUCP, and no significant impact would occur.

Mitigation Measure(s)

No mitigation measures are required.

3.11.4 Decommissioning/Restoration and Residual Impacts

Decommissioning/Restoration

Decommissioning and restoration would not physically divide an established community or conflict with any applicable land use plans, policies, or regulations. Decommissioning would be conducted in compliance with a required Reclamation Plan that would be implemented at the end of the proposed project's life and would adhere to Imperial County's decommissioning requirements. Further, decommissioning activities would be subject to mandatory compliance with applicable local, State, and federal regulations designed to avoid adverse impacts to the project area and surrounding environment. Therefore, environmental impacts due to a conflict with an applicable land use plan, policy or regulation would be less than significant.

Residual

With the approval of a CUP and reclamation plan to address post-project decommissioning, the proposed project would generally be consistent with applicable state, regional, and local plans and policies. Based on these circumstances, the proposed project would not result in any residual significant and unmitigable land use impacts.

This page is intentionally blank.

3.12 Noise and Vibration

This section identifies the ambient noise environment for the project area and describes applicable federal, state, and local regulations, potential project-related noise and vibration impacts, and recommended mitigation measures to avoid or reduce potential impacts of the proposed project. The information for this section is summarized from a project-specific Noise Impact Assessment, prepared by ECORP Consulting, Inc. This report is included in Appendix J of this EIR.

3.12.1 Existing Conditions

Noise

Noise is defined as unwanted sound. Pressure waves traveling through air exert a force registered by the human ear as sound. Sound, traveling in the form of waves from a source, exerts a sound pressure level (referred to as sound level), which is measured in decibels (dB), with zero dB corresponding roughly to the threshold of human hearing and 120 to 140 dB corresponding to the threshold of pain.

The typical human ear is not equally sensitive to all frequencies of the audible sound spectrum. Consequently, when assessing potential noise impacts, sound is measured using an electronic filter that de-emphasizes the frequencies below 1,000 hertz (Hz) and above 5,000 Hz to imitate the human ear's decreased sensitivity to low and extremely high frequencies. This emulation of the human ear's frequency sensitivity is referred to as A-weighting and is expressed in units of dBA. Frequency A weighting follows an international standard method of frequency de-emphasis and is typically applied to community noise measurements. In practice, the specific sound level from a source is measured using a meter incorporating an electrical filter corresponding to the A-weighting curve. All noise levels reported are A-weighted unless otherwise stated.

The dB scale is logarithmic and an increase of 10 dBA is generally perceived as a doubling in loudness. For example, a 70-dBA sound is half as loud as an 80-dBA sound and twice as loud as a 60-dBA sound.

Typical noise levels associated with common noise sources are depicted in Figure 3.12-1.

Figure 3.12-1. Common Noise Levels

Common Outdoor Activities	Noise Level (dBA)	Common Indoor Activities
<u>Jet Fly-over at 300m (1000 ft)</u>	110	<u>Rock Band</u>
<u>Gas Lawn Mower at 1 m (3 ft)</u>	100	
<u>Diesel Truck at 15 m (50 ft), at 80 km (50 mph)</u>	90	<u>Food Blender at 1 m (3 ft)</u>
<u>Noisy Urban Area, Daytime</u>	80	<u>Garbage Disposal at 1 m (3 ft)</u>
<u>Gas Lawn Mower, 30 m (100 ft)</u>	70	<u>Vacuum Cleaner at 3 m (10 ft)</u>
<u>Commercial Area</u>		<u>Normal Speech at 1 m (3 ft)</u>
<u>Heavy Traffic at 90 m (300 ft)</u>	60	
<u>Quiet Urban Daytime</u>	50	<u>Large Business Office</u>
		<u>Dishwasher Next Room</u>
<u>Quiet Urban Nighttime</u>	40	<u>Theater, Large Conference</u>
<u>Quiet Suburban Nighttime</u>		<u>Room (Background)</u>
	30	<u>Library</u>
<u>Quiet Rural Nighttime</u>		<u>Bedroom at Night,</u>
	20	<u>Concert Hall (Background)</u>
		<u>Broadcast/Recording Studio</u>
	10	
<u>Lowest Threshold of Human Hearing</u>	0	<u>Lowest Threshold of Human Hearing</u>

Source: Appendix J of this EIR

Sound Propagation and Attenuation

Noise can be generated by a number of sources, including mobile sources such as automobiles, trucks and airplanes, and stationary sources such as construction sites, machinery, and industrial operations. Sound spreads (propagates) uniformly outward in a spherical pattern, and the sound level decreases (attenuates) at a rate of approximately 6 dB for each doubling of distance from a stationary or point source. Sound from a line source, such as a highway, propagates outward in a cylindrical pattern, often referred to as cylindrical spreading. Sound levels attenuate at a rate of approximately 3 dB for each doubling of distance from a line source, such as a roadway, depending on ground surface characteristics. No excess attenuation is assumed for hard surfaces like a parking lot or a body of water. Soft surfaces, such as soft dirt or grass, can absorb sound, so an excess ground-attenuation

value of 1.5 dB per doubling of distance is normally assumed. For line sources, an overall attenuation rate of 3 dB per doubling of distance is assumed (Appendix J of this EIR).

Noise levels may also be reduced by intervening structures; generally, a single row of detached buildings between the receptor and the noise source reduces the noise level by about 5 dBA, while a solid wall or berm generally reduces noise levels by 10 to 20 dBA. However, noise barriers or enclosures specifically designed to reduce site-specific construction noise can provide a sound reduction of 35 dBA or greater. To achieve the most potent noise-reducing effect, a noise enclosure/barrier must physically fit in the available space, must completely break the “line of sight” between the noise source and the receptors, must be free of degrading holes or gaps, and must not be flanked by nearby reflective surfaces (Appendix J of this EIR).

The manner in which older homes in California were constructed generally provides a reduction of exterior-to-interior noise levels of about 20 to 25 dBA with closed windows. The exterior-to-interior reduction of newer residential units is generally 30 dBA or more. Generally, in exterior noise environments ranging from 60 dBA Community Noise Equivalent Level (CNEL) to 65 dBA CNEL, interior noise levels can typically be maintained below 45 dBA, a typically residential interior noise standard, with the incorporation of an adequate forced air mechanical ventilation system in each residential building, and standard thermal-pane residential windows/doors with a minimum rating of Sound Transmission Class (STC) 28. (STC is an integer rating of how well a building partition attenuates airborne sound (Appendix J of this EIR).

Noise Descriptors

The decibel scale alone does not adequately characterize how humans perceive noise. The dominant frequencies of a sound have a substantial effect on the human response to that sound. Several rating scales have been developed to analyze the adverse effect of community noise on people. Because environmental noise fluctuates over time, these scales consider that the effect of noise on people is largely dependent on the total acoustical energy content of the noise, as well as the time of day when the noise occurs. The L_{eq} is a measure of ambient noise, while the L_{dn} and CNEL (Community Noise Equivalent Level) are measures of community noise.

The A weighted decibel sound level scale gives greater weight to the frequencies of sound to which the human ear is most sensitive. Because sound levels can vary markedly over a short period of time, a method for describing either the average character of the sound or the statistical behavior of the variations must be utilized. Most commonly, environmental sounds are described in terms of an average level that has the same acoustical energy as the summation of all the time-varying events.

Human Response to Noise

The human response to environmental noise is subjective and varies considerably from individual to individual. Noise in the community has often been cited as a health problem, not in terms of actual physiological damage, such as hearing impairment, but in terms of inhibiting general well-being and contributing to undue stress and annoyance. The health effects of noise in the community arise from interference with human activities, including sleep, speech, recreation, and tasks that demand concentration or coordination. Hearing loss can occur at the highest noise intensity levels.

Noise environments and consequences of human activities are usually well represented by median noise levels during the day or night or over a 24-hour period. Environmental noise levels are generally considered low when the CNEL is below 60 dBA, moderate in the 60 to 70 dBA range, and high above 70 dBA. Examples of low daytime levels are isolated, natural settings with noise levels as low as 20

dBA and quiet, suburban, residential streets with noise levels around 40 dBA. Noise levels above 45 dBA at night can disrupt sleep. Examples of moderate-level noise environments are urban residential or semi-commercial areas (typically 55 to 60 dBA) and commercial locations (typically 60 dBA). Regarding increases in A-weighted noise levels (dBA), the following relationships should be noted in understanding this analysis:

- Except in carefully controlled laboratory experiments, a change of 1 dBA cannot be perceived by humans.
- Outside of the laboratory, a 3-dBA change is considered a just-perceivable difference.
- A change in level of at least 5 dBA is required before any noticeable change in community response would be expected. An increase of 5 dBA is typically considered substantial.
- A 10-dBA change is subjectively heard as an approximate doubling in loudness and would almost certainly cause an adverse change in community response.

Existing Ambient Noise Levels

The project site consists of flat undeveloped land and is bound by agricultural land to the north with SR 98 beyond, agricultural land to the west, vacant undisturbed land to the east, and a mix of vacant undisturbed and agricultural land to the south. In order to quantify existing ambient noise levels in the project area, ECORP Consulting, Inc. conducted three short-term noise measurements on January 12, 2021. The noise measurement sites were representative of typical existing noise exposure within and adjacent to the project site during the daytime. The 15-minute measurements were taken between 1:51 p.m. and 2:45 p.m. Short-term (L_{eq}) measurements are considered representative of the noise levels throughout the day. As shown in Table 3.12-1, the existing noise levels (baseline) in the project vicinity range from 65.4 to 68.7 dBA.

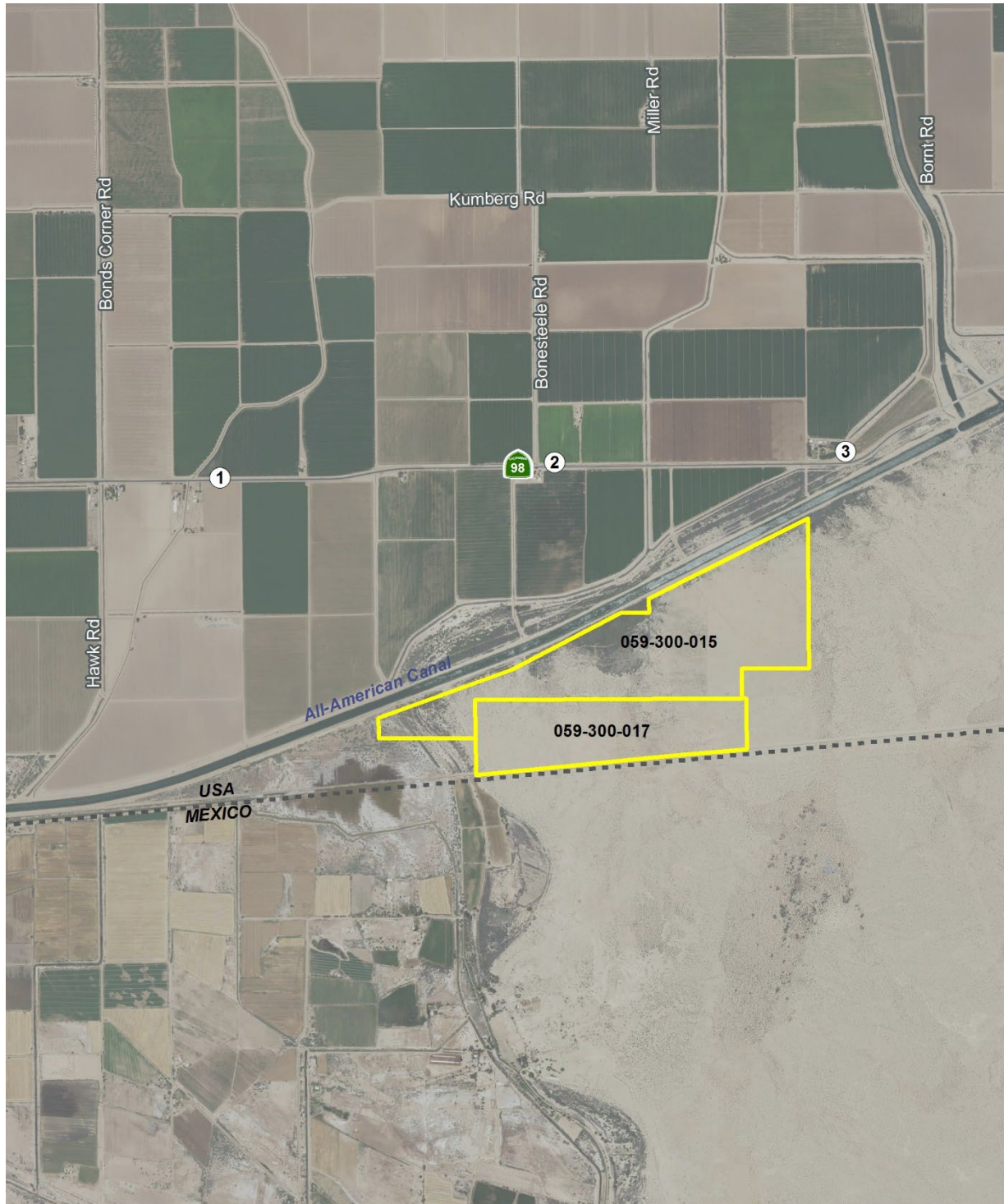
Table 3.12-1. Existing (Baseline) Noise Measurements

Measurement Location Number	Location	L_{eq} dBA	L_{min} dBA	L_{max} dBA	Time
1	CA-98 East of Bonds Corner Road	65.4	36.3	79.8	2:30 p.m.- 2:45 p.m.
2	CA-98 East of Bonesteel Road	68.7	25.2	86.2	2:10 p.m. – 2:25 p.m.
3	CA-98 Southeastern Extent	66.1	40.8	81.5	1:51 p.m. – 2:06 p.m.

Source: Appendix J of this EIR

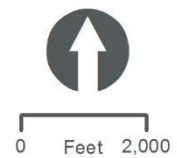
The most common noise in the project vicinity is produced by automotive vehicles (e.g., cars, trucks, buses, motorcycles) traveling on SR 98. Traffic moving along streets produces a sound level that remains relatively constant and is part of the minimum ambient noise level in the project vicinity.

Figure 3.12-2. Noise Measurement Locations



Legend

- VEGA SES 4 Project Parcels
- Noise Measurement Location



Noise Sensitive Land Uses

Noise-sensitive land uses are generally considered to include those uses where noise exposure could result in health-related risks to individuals, as well as places where quiet is an essential element of their intended purpose. Residential dwellings are of primary concern because of the potential for increased and prolonged exposure of individuals to both interior and exterior noise levels. Additional land uses such as hospitals, historic sites, cemeteries, and certain recreation areas are considered sensitive to increases in exterior noise levels. Schools, churches, hotels, libraries, and other places where low interior noise levels are essential are also considered noise-sensitive land uses.

The nearest existing noise-sensitive land use to the project site is a single-family residence located approximately 1,342 feet from the northeastern corner of project site.

Vibration

Vibration Sources and Characteristics

Sources of earthborne vibrations include natural phenomena (e.g., earthquakes, volcanic eruptions, sea waves, landslides) or manmade causes (explosions, machinery, traffic, trains, construction equipment, etc.). Vibration sources may be continuous (e.g., factory machinery) or transient (e.g., explosions). Ground vibration consists of rapidly fluctuating motions or waves with an average motion of zero. Several different methods are typically used to quantify vibration amplitude. One is the peak particle velocity (PPV); another is the root mean square (RMS) velocity. The PPV is defined as the maximum instantaneous positive or negative peak of the vibration wave. The RMS velocity is defined as the average of the squared amplitude of the signal. The PPV and RMS vibration velocity amplitudes are used to evaluate human response to vibration.

PPV is generally accepted as the most appropriate descriptor for evaluating the potential for building damage. For human response, however, an average vibration amplitude is more appropriate because it takes time for the human body to respond to the excitation (the human body responds to an average vibration amplitude, not a peak amplitude). Because the average particle velocity over time is zero, the RMS amplitude is typically used to assess human response. The RMS value is the average of the amplitude squared over time, typically a 1- sec. period (Appendix J of this EIR).

Table 3.12-2 displays the reactions of people and the effects on buildings produced by continuous vibration levels. To sensitive individuals, vibrations approaching the threshold of perception can be annoying. Low-level vibrations frequently cause irritating secondary vibration, such as a slight rattling of windows, doors, or stacked dishes. The rattling sound can give rise to exaggerated vibration complaints, even though there is very little risk of actual structural damage. In high-noise environments, which are more prevalent where groundborne vibration approaches perceptible levels, this rattling phenomenon may also be produced by loud airborne environmental noise causing induced vibration in exterior doors and windows.

Ground vibration can be a concern in instances where buildings shake, and substantial rumblings occur. However, it is unusual for vibration from typical urban sources such as buses and heavy trucks to be perceptible. For instance, heavy-duty trucks generally generate groundborne vibration velocity levels of 0.006 PPV at 50 feet under typical circumstances, which as identified in Table 3.12-2 is considered very unlikely to cause damage to buildings of any type.



Table 3.12-2. Human Reaction and Damage to Buildings for Continuous or Frequent Intermittent Vibration Levels

Peak Particle Velocity (inches/second)	Approximate Vibration Velocity Level (VdB)	Human Reaction	Effect on Buildings
0.006 – 0.019	67 – 74	Range of threshold of perception	Vibrations unlikely to cause damage of any type
0.08	87	Vibrations readily perceptible	Recommended upper level to which ruins and ancient monuments should be subjected
0.1	92	Level at which continuous vibrations may begin to annoy people, particularly those involved in vibration sensitive activities	Virtually no risk of architectural damage to normal buildings
0.2	94	Vibrations may begin to annoy people in buildings	Threshold at which there is a risk of architectural damage to normal dwellings
0.4 – 0.6	98 - 104	Vibrations considered unpleasant by people subjected to continuous vibrations and unacceptable to some people walking on bridges	Architectural damage and possibly minor structural damage

Source: Appendix J of this EIR

Common sources for groundborne vibration are planes, trains, and construction activities such as earth-moving which requires the use of heavy-duty earth moving equipment. Construction-related ground vibration is normally associated with impact equipment such as pile drivers, jackhammers, and the operation of some heavy-duty construction equipment, such as dozers and trucks. Vibration decreases rapidly with distance. Groundborne vibration levels associated with typical construction equipment at 25 feet distant are summarized in Table 3.12-3.

Table 3.12-3. Representative Vibration Source Levels for Construction Equipment

Equipment Type	Peak Particle Velocity at 25 Feet (Inches per Second)
Large Bulldozer	0.089
Caisson Drilling	0.089
Loaded Trucks	0.076
Hoe Ram	0.089
Jackhammer	0.035
Small Bulldozer/Tractor	0.003
Vibratory Roller	0.210

Source: Appendix J of this EIR

Proximity to Airports

The project site is not located within 2 miles of a public airport or a public use airport. The nearest airports to the project site are the Calexico International Airport located approximately 10 miles west of the project site and Holtville Airport located approximately 10 miles north of the project site. According to the Imperial County Airports Department, the Holtville Airport is currently closed.

3.12.2 Regulatory Setting

This section identifies and summarizes federal, state, and local laws, policies, and regulations that are applicable to the project.

Federal

Occupational Safety and Health Act of 1970

OSHA regulates onsite noise levels and protects workers from occupational noise exposure. To protect hearing, worker noise exposure is limited to 90 dBA over an eight-hour work shift (29 Code of Regulations 1910.95). Employers are required to develop a hearing conservation program when employees are exposed to noise levels exceeding 85 dBA. These programs include provision of hearing protection devices and testing employees for hearing loss on a periodic basis.

State

State of California General Plan Guidelines

The State of California regulates vehicular and freeway noise affecting classrooms, sets standards for sound transmission and occupational noise control, and identifies noise insulation standards and airport noise/land-use compatibility criteria. The State of California General Plan Guidelines, published by the Governor's Office of Planning and Research (OPR), also provides guidance for the acceptability of projects within specific CNEL/ L_{dn} contours. The guidelines also present adjustment factors that may be used in order to arrive at noise acceptability standards that reflect the noise control goals of the community, the particular community's sensitivity to noise, and the community's assessment of the relative importance of noise pollution.

State Office of Planning and Research Noise Element Guidelines

The State OPR Noise Element Guidelines include recommended exterior and interior noise level standards for local jurisdictions to identify and prevent the creation of incompatible land uses due to noise. The Noise Element Guidelines contain a Land Use Compatibility table that describes the compatibility of various land uses with a range of environmental noise levels in terms of the CNEL. The County of Imperial has utilized the adjustment factors provided and has modified the state's Land Use Compatibility standards for the purpose of implementing the Noise Element of its General Plan. Table 3.12-4 summarizes the acceptable and unacceptable community noise exposure limits for various land use categories as currently defined by the State of California. These community noise exposure limits are also incorporated into the County of Imperial General Plan Noise Element.



Table 3.12-4. Land Use Compatibility for Community Noise Environments

Land Use Category	Community Noise Exposure – L _{dn} or CNEL (dBA)							
	50	55	60	65	70	75	80	
Residential	█	█	█	█				
			█	█	█			
						█	█	
							█	█
Transient Lodging – Motel, Hotel	█	█	█	█	█			
			█	█	█	█	█	
							█	█
Schools, Libraries, Churches, Hospitals, Nursing Homes	█	█	█					
			█	█	█			
						█	█	█
								█
Auditorium, Concert Hall, Amphitheaters								
	█	█	█	█	█	█		
						█	█	█
Sports Arena, Outdoor Spectator Sports								
	█	█	█	█	█	█	█	
							█	█
Playgrounds, Neighborhood Parks	█	█	█	█	█	█		
							█	█
							█	█
Golf Courses, Riding Stables, Water Recreation, Cemeteries	█	█	█	█	█	█		
							█	█
								█
Office Buildings, Business, Commercial and Professional	█	█	█	█	█			
				█	█	█	█	
							█	█
Industrial, Manufacturing, Utilities, Agriculture	█	█	█	█	█	█		

Table 3.12-4. Land Use Compatibility for Community Noise Environments

Land Use Category		Community Noise Exposure – L _{dn} or CNEL (dBA)							
		50	55	60	65	70	75	80	
	Normally Acceptable	Specified land use is satisfactory, based upon the assumption that any buildings involved are of normal conventional construction, without any special noise insulation requirements.							
	Conditionally Acceptable	New construction or development should be undertaken only after a detailed analysis of the noise reduction requirements is made and needed noise insulation features are included in the design.							
	Normally Unacceptable	New construction or development should be discouraged. If new construction or development does proceed, a detailed analysis of the noise reduction requirement must be made and needed noise insulation features included in the design.							
	Clearly Unacceptable	New construction or development generally should not be undertaken.							

Source: OPR 2017; ICPDS 1993

CNEL - community noise equivalent level; dBA – A-weighted decibel; L_{dn} – day-night average sound level

Local

County of Imperial General Plan Noise Element

The County of Imperial General Plan Noise Element identifies and defines existing and future environmental noise levels from sources of noise within or adjacent to the County of Imperial; establishes goals and objectives to address noise impacts and provides Implementation Programs to implement adopted goals and objectives. Table 3.12-5 summarizes the project’s consistency with the applicable General Plan noise policies. While this EIR analyzes the project’s consistency with the General Plan pursuant to CEQA Guidelines Section 15125(d), the Imperial County Board of Supervisors ultimately determines consistency with the General Plan.

The County of Imperial has established the following interior noise standards to be considered in acoustical analyses:

- The interior noise standard for detached single family dwellings shall be 45 dB CNEL.
- The interior noise standard for schools, libraries, offices and other noise-sensitive areas where the occupancy is normally only in the daytime, shall be 50 dB averaged over a 1-hour period (L_{eq}(1)).



Table 3.12-5. Project Consistency with Applicable General Plan Noise Policies

General Plan Policies	Consistency with General Plan	Analysis
<p>1. Acoustical Analysis of proposed projects. The County shall require the analysis of proposed discretionary projects, which may generate excessive noise, or which may be impacted by existing excessive noise levels.</p>	<p>Consistent</p>	<p>Under existing conditions, the ambient noise environment is characterized as relatively quiet with peak noise levels influenced by vehicular traffic traveling on SR 98. Given that the project is not characterized as a sensitive land use, project facilities would be unaffected by existing noise levels. The project facilities would be constructed within areas zoned for agricultural use with noise levels up to 70 dBA identified as normally acceptable. Project operations are expected to produce noise levels that would not exceed County standards and, hence impacts are expected to be less than significant.</p> <p>This EIR provides an analysis of the potential short- and long-term noise impacts of the project. As discussed, short-term and long-term noise levels were found to be less than significant.</p>
<p>2. Noise/Land Use Compatibility. Where acoustical analysis of a proposed project is required, the County shall identify and evaluate potential noise/land use conflicts that could result from the implementation of the project. Projects which may result in noise levels that exceed the “Normally Acceptable” criteria of the Noise/Land Use Compatibility Guidelines shall include mitigation measures to eliminate or reduce the adverse noise impacts to an acceptable level.</p>	<p>Consistent</p>	<p>Noise levels associated with project operations would not exceed noise limits for the A-3 zone. See Section 3.12.3 for additional discussion.</p>
<p>4. Interior Noise Environment. Where acoustical analysis of a proposed project is required, the County shall identify and evaluate projects to ensure compliance to the California (Title 24) interior noise standards and the additional requirements of this Element.</p>	<p>Consistent</p>	<p>This EIR provides an analysis of the potential short- and long-term noise impacts of the project. As discussed, short-term and long-term noise levels were found to be less than significant.</p> <p>Noise levels associated with project operations would not exceed noise limits for the A-3 zone.</p>
<p>5. New Noise Generating projects. The County shall identify and evaluate projects which have the potential to generate noise in excess of the Property Line Noise Limits. An acoustical analysis must be submitted which demonstrates the project’s compliance.</p>	<p>Consistent</p>	<p>This EIR provides an analysis of the potential short- and long-term noise impacts of the project. As discussed, short-term and long-term noise levels were found to be less than significant.</p> <p>Noise levels associated with project operations would not exceed noise limits for the A-3 zone.</p>

Table 3.12-5. Project Consistency with Applicable General Plan Noise Policies

General Plan Policies	Consistency with General Plan	Analysis
6. Projects Which Generate Off-site Traffic Noise. The acoustical analysis shall identify and evaluate projects, which would generate traffic and increase noise levels on off-site roadways. If the project site has the potential to cause a significant noise impact on sensitive receptors along those roadways, the acoustical analysis report shall consider noise reduction measures to reduce the impact to a level less than significant.	Consistent	As described in Chapter 2, the project would involve a minimal number of operational related vehicle trips and therefore, is unlikely to produce any increase in traffic noise levels on local roadways.

Source: ICPDS 1993

Construction Noise Standards

Construction noise, from a single piece of equipment or a combination of equipment, shall not exceed 75 dB L_{eq} , when averaged over an eight (8) hour period, and measured at the nearest sensitive receptor. This standard assumes a construction period, relative to an individual sensitive receptor of days or weeks. In cases of extended length construction times, the standard may be tightened so as not to exceed 75 dB L_{eq} when averaged over a one (1) hour period.

Construction equipment operation are required to be limited to the hours of 7:00 a.m. to 7:00 p.m., Monday through Friday, and 9:00 a.m. to 5:00 p.m. Saturday. No commercial construction operations are permitted on Sunday or holidays. In cases of a person constructing or modifying a residence for himself/herself, and if the work is not being performed as a business, construction equipment operations may be performed on Sundays and holidays between the hours of 9:00 a.m. and 5:00 p.m. Such non-commercial construction activities may be further restricted where disturbing, excessive, or offensive noise causes discomfort or annoyance to reasonable persons of normal sensitivity residing in an area.

County of Imperial Noise Ordinance

Noise generating sources in Imperial County are regulated under the County of Imperial Codified Ordinances, Title 9, Division 7 (Noise Abatement and Control). Noise limits are established in Chapter 2 of this ordinance. Under Section 90702.00 of this rule, 70 dB is the normally acceptable limit for the Industrial, Manufacturing, Utilities, and Agricultural category of land use (Table 3.12-6).



Table 3.12-6. Imperial County Exterior Noise Standards

Land Use Zone	Time Period	Noise Level, L_{eq} 1-hour
R-1 Residential	Night (10 p.m. to 7 a.m.)	45 dBA
	Day (7 a.m. to 10 p.m.)	50 dBA
R-2 Residential	Night (10 p.m. to 7 a.m.)	50 dBA
	Day (7 a.m. to 10 p.m.)	55 dBA
R-3, R-4, and all other residential	Night (10 p.m. to 7 a.m.)	50 dBA
	Day (7 a.m. to 10 p.m.)	55 dBA
Commercial	Night (10 p.m. to 7 a.m.)	55 dBA
	Day (7 a.m. to 10 p.m.)	60 dBA
Manufacturing, other industrial, agricultural, and extraction industry	Anytime	70 dBA
Industrial	Anytime	75 dBA

dBA – A-weighted decibel; L_{eq} – equivalent sound level

Imperial County Right-to-Farm Ordinance

In recognition of the role of agriculture in the county, the County of Imperial has adopted a “right-to-farm” ordinance (County of Imperial Codified Ordinances, Division 2, Title 6: Right to Farm). A “right-to-farm” ordinance creates a legal presumption that ongoing standard farming practices are not a nuisance to adjoining residences and requires a disclosure to landowners near agricultural land operations or areas zoned for agricultural purposes. The disclosure advises persons regarding potential discomfort and inconvenience that may occur from operating machinery as a result of conforming and accepted agricultural operations.

3.12.3 Impacts and Mitigation Measures

This section presents the significance criteria used for considering project impacts on biological resources, the methodology employed for the evaluation, an impact evaluation, and mitigation requirements, if necessary.

Thresholds of Significance

Based on CEQA Guidelines Appendix G, project impacts related to noise and vibration are considered significant if any of the following occur:

- Generate a substantial temporary or permanent increase in ambient noise levels in the vicinity of the project in excess of standards established in the local general plan or noise ordinance, or applicable standards of other agencies.
- Generate excessive groundborne vibration or groundborne noise levels.
- For a project located in the vicinity of a private airstrip of an airport land use plan, or where such a plan has not been adopted, within two miles of a public airport or public use airport,

would the project expose people residing or working in the project area to excessive noise levels.

Methodology

Noise and Vibration

This analysis of the existing and future noise environments is based on empirical observations. Predicted construction noise levels were calculated utilizing the FHWA's Roadway Construction Model (see Appendix J of this EIR for details). Groundborne vibration levels associated with construction-related activities for the project were evaluated utilizing typical groundborne vibration levels associated with construction equipment. Potential groundborne vibration impacts related to structural damage and human annoyance were evaluated, taking into account the distance from construction activities to nearby structures and typically applied criteria for structural damage and human annoyance.

In order to estimate the worst-case operational noise levels that may occur at the nearest noise-sensitive receptor, onsite operational noise levels have been calculated with the SoundPLAN 3D noise model (which predicts noise propagation from a noise source based on the location, noise level, and frequency spectra of the noise sources as well as the geometry and reflective properties of the local terrain, buildings, and barriers), coupled with noise measurements that were taken by ECORP Consulting, Inc. (ECORP) at an existing solar energy generation facility. Specifically, ECORP conducted a 30-minute reference noise measurement within the IVC solar generation facility in Imperial County with a Larson Davis SoundExpert LxT precision sound-level meter, which satisfies the American National Standards Institute for general environmental noise measurement instrumentation. This reference measurement identified an ambient noise environment of 47.1 dBA at the existing solar energy generation facility (see Appendix J of this EIR for details). Therefore, a noise level of 47.1 dBA was employed as the reference noise level in the SoundPLAN 3D noise model to determine noise-level propagation associated with project operations.

Impact Analysis

Impact 3.12-1 Would the project generate a substantial temporary or permanent increase in ambient noise levels in the vicinity of the project in excess of standards established in the local general plan or noise ordinance, or applicable standards of other agencies?

Onsite Construction Noise

Construction noise associated with the proposed project would be temporary and would vary depending on the nature of the activities being performed. Noise generated would primarily be associated with the operation of off-road equipment for onsite construction activities as well as construction vehicle traffic on area roadways. Construction noise typically occurs intermittently and varies depending on the nature or phase of construction (e.g., land clearing, grading, excavation, paving). Noise generated by construction equipment, including earth movers, material handlers, and portable generators, can reach high levels. Typical operating cycles for these types of construction equipment may involve one or two minutes of full power operation followed by three to four minutes at lower power settings. Other primary sources of acoustical disturbance would be random incidents, which would last less than one minute (such as dropping large pieces of equipment or the hydraulic



movement of machinery lifts). During construction, exterior noise levels could negatively affect sensitive land uses in the vicinity of the construction site.

Nearby noise-sensitive land uses consist of a scattering of single-family residential units located within 1 mile of the proposed project site boundary to the north across the All-American Canal. The closest sensitive receptor is located approximately 1,342 feet from the northeastern corner of the project site. As previously described, the County’s General Plan Noise Element states construction equipment operation shall be limited to the hours of 7:00 a.m. to 7:00 p.m., Monday through Friday, and 9:00 a.m. to 5:00 p.m. on Saturdays. No commercial construction operations are permitted on Sundays or holidays. Construction noise, from a single piece of equipment or a combination of equipment, shall not exceed 75 dB L_{eq}, when averaged over an 8-hour period, and measured at the nearest sensitive receptor. This standard assumes a construction period, relative to an individual sensitive receptor of days or weeks. In cases of extended length construction times, the standard may be tightened so as not to exceed 75 dB L_{eq} when averaged over a one 1-hour period.

The anticipated short-term construction noise levels generated for the necessary construction equipment are presented in Table 3.12-7.

Table 3.12-7. Construction Average Noise Levels (dBA) at the Nearest Receptor

Equipment	Estimated Exterior Construction Noise Level at Nearest Receptor	Construction Noise Standards (dBA L _{eq})	Exceeds Standards?
Site Preparation			
Rubber Tired Dozers (2)	46.6 (each)	75	No
Tractors/Loaders/Backhoes (2)	51.4 (each)	75	No
Combined Site Preparation Equipment	55.7	75	No
Grading			
Excavators (4)	48.2 (each)	75	No
Graders (3)	52.4 (each)	75	No
Rubber Tired Dozers (2)	49.1 (each)	75	No
Scrapers (2)	51 (each)	75	No
Tractors/Loaders/Backhoes (4)	51.4 (each)	75	No
Combined Grading Equipment	62.5	75	No
Facility Construction			
Crane	44.0 (each)	75	No
Paver	45.6 (each)	75	No
Paving Equipment (2)	53.9 (each)	75	No
Pile Drivers (4)	65.7 (each)	75	No
Rollers (2)	44.4 (each)	75	No

Table 3.12-7. Construction Average Noise Levels (dBA) at the Nearest Receptor

Equipment	Estimated Exterior Construction Noise Level at Nearest Receptor	Construction Noise Standards (dBA Leq)	Exceeds Standards?
Rough Terrain Forklifts (4)	50.8 (each)	75	No
Tractors/Loaders/Backhoes	51.4 (each)	75	No
Trenchers (2)	48.8 (each)	75	No
Combined Construction, Trenching, and paving	72.2	75	No

Source: Appendix J of this EIR

Notes: The nearest residence is located approximately 1,342 feet from the project boundary.

Leq = The equivalent energy noise level, is the average acoustic energy content of noise for a stated period of time. Thus, the Leq of a time-varying noise and that of a steady noise are the same if they deliver the same acoustic energy to the ear during exposure. For evaluating community impacts, this rating scale does not vary, regardless of whether the noise occurs during the day or the night.

As shown in Table 3.12-7, no individual or cumulative pieces of construction equipment would exceed the 75 dBA Imperial County construction noise standard during any phase of construction at the nearest noise-sensitive receptor. Therefore, the proposed project would not generate a substantial temporary increase in ambient noise levels in the vicinity of the project in excess of standards established in the local general plan or noise ordinance, or applicable standards of other agencies during construction. Impacts would be less than significant.

Offsite Construction Worker Traffic Noise

Project construction would also result in additional traffic on adjacent roadways over the time period that construction occurs. The number of on-site construction workers for the proposed project is not expected to exceed 150 workers at any one time. The number of on-site construction workers for the battery storage facility and the substation is not expected to exceed 100 workers at any one time. Onsite parking would be provided for all construction workers. According to the Traffic Impact Study prepared for the project (Appendix K of this EIR), a maximum of 510 daily automobile trips would be generated during project construction, accounting for construction worker commutes and equipment deliveries (see Appendix K of this EIR for details). The majority of these trips are expected to be accommodated on SR 98, SR 7, and Interstate 8.

Doubling of traffic on a roadway is required to result in an increase of 3 dB (outside of the laboratory, a 3-dBA change is considered a just-perceivable difference). SR 98 currently accommodates 2,400 average daily traffic trips, while SR 7 and Interstate 8 accommodate 6,700 average daily trips and 14,000 average daily trips, respectively. Thus, the estimated 510 daily trips during project construction would not result in a doubling of traffic on these facilities, and its contribution to existing traffic noise would not be perceptible.

Bonds Corner Road and West Heber Road are also projected to accommodate construction-related traffic with an estimated 69 daily trips on Bonds Corner Road and 5 daily trips on West Heber Road over the course of construction. These two facilities are classified as “minor arterial” roads by the County General Plan Circulation and Scenic Highways Element and are expected to accommodate approximately 14,800 daily trips. While the Circulation and Scenic Highways Element does not identify specific traffic counts for Bonds Corner Road, it estimates between 2,020 and 16,700 average daily



trips on West Heber Road. Thus, the estimated 510 daily trips during project construction would not result in a doubling of traffic on these facilities, and its contribution to existing traffic noise would not be perceptible.

Based on the considerations above, the proposed project would not generate a substantial temporary increase in ambient noise levels related to construction worker traffic in the vicinity of the project in excess of standards established in the local general plan or noise ordinance, or applicable standards of other agencies during construction. Impacts would be less than significant.

Operation

The main stationary operational noise associated with the project would be from the proposed transformers, inverters, substation, and transmission lines. Onsite project operations have been calculated using the SoundPLAN 3D noise model. As previously stated, a noise level of 47.1 dBA was employed as the reference noise level in the SoundPLAN 3D noise model to determine noise-level propagation associated with the project operations. Table 3.12-8 shows the predicted project noise levels at the nearest noise-sensitive land use, a single-family residence located approximately 1,343 feet north of the project site, across the All-American Canal.

Table 3.12-8. Modeled Operational Noise Levels at Nearest Sensitive Receptor

Location	Modeled Operational Noise Attributed to Project (L _{eq} dBA)	County Daytime Standard (L _{eq} dB)	County Nighttime Standard (L _{eq} dB)	Exceed Standard?
Property line of the nearest residence	32.4	50.0	45.0	No

Source: Appendix J of this EIR

Note: Reference noise measurement used to calculate Project onsite noise propagation identified at 47.1 dBA, per 30-minute measurements taken at a VEGA SES 4 solar generation facility in Imperial County.

As shown in Table 3.12-8, project operational noise would not exceed County daytime or nighttime standards.

Project operations would result in minimal additional traffic on adjacent roadways. The only visitors to the site would be that of repair or maintenance workers, whose presence at the site would be infrequent. Sporadic vehicle activity resulting from maintenance and operations trips would not result in a doubling of traffic, and therefore its contribution to existing traffic noise would not be perceptible.

Given the above, project operation would not generate a substantial permanent increase in ambient noise levels in the vicinity of the project in excess of standards established in the local general plan or noise ordinance, or applicable standards of other agencies during construction. Impacts would be less than significant.

Mitigation Measure(s)

No mitigation measures are required.

Impact 3.12-2 Would the project generate excessive groundborne vibration or groundborne noise levels?

Construction

Excessive groundborne vibration impacts result from continuously occurring vibration levels. Increases in groundborne vibration levels attributable to the project would be primarily associated with short-term construction-related activities. Construction on the project site would have the potential to result in varying degrees of temporary groundborne vibration, depending on the specific construction equipment used and the operations involved. Ground vibration generated by construction equipment spreads through the ground and diminishes in magnitude with increases in distance.

As stated in Section 3.12.1 above, construction-related ground vibration is normally associated with impact equipment such as pile drivers, jackhammers, and the operation of some heavy-duty construction equipment, such as dozers and trucks. Vibration decreases rapidly with distance and it is acknowledged that construction activities would occur throughout the project site and would not be concentrated at the point closest to sensitive receptors. Groundborne vibration levels associated with typical construction equipment at 25 feet distant are summarized in Table 3.12-3.

The County of Imperial does not regulate vibrations associated with construction. However, a discussion of construction vibration is included for informational purposes. Caltrans and the Federal Transit Authority (FTA) have developed two of the decisive works in the assessment of vibrations from transportation and construction sources (Caltrans 2020; FTA 2018). Caltrans recommends a standard threshold of 0.2 inch per second PPV with respect to the prevention of structural damage for older residential buildings (Caltrans 2020). This is also the level at which vibrations may begin to annoy people in buildings. Consistent with FTA recommendations (FTA 2018) for calculating construction vibration, construction vibration was measured from the center of the project site. The nearest structure of concern to the construction site, with regard to groundborne vibrations, is the All-American Canal located 100 feet from the proposed project site boundary (Appendix J of this EIR).

Potential project construction vibration levels were calculated based on the representative vibration levels presented for various construction equipment types in Table 3.12-3 and the construction vibration assessment methodology published by the FTA (FTA 2018). Table 3.12-9 presents the expected project-related vibration levels at a distance of 100 feet.

Table 3.12-9. Project Construction Vibration Levels at 100 Feet

Receiver PPV Levels (Inch per Second)					Peak Vibration	Threshold	Exceed Threshold?
Large Bulldozer, Caisson Drilling, and Hoe Ram	Loaded Trucks	Jackhammer	Small Bulldozer	Vibratory Roller			
0.011	0.009	0.004	0.000	0.026	0.026	0.2	No

Source: Appendix J of this EIR

As shown in Table 3.12-9, vibration as a result of construction activities would not exceed 0.2 PPV at the nearest structure. Thus, project construction would not exceed the recommended vibration threshold and this impact would be less than significant.



Operation

Project operations would not include the use of any large-scale stationary equipment that would result in excessive vibration levels, nor would it involve any operational activities that would result in excessive vibration. Therefore, the project would result in no impact associated with groundborne vibration during operations.

Mitigation Measure(s)

No mitigation measures are required.

Impact 3.12-3 For a project located in the vicinity of a private airstrip of an airport land use plan, or where such a plan has not been adopted, within two miles of a public airport or public use airport, would the project expose people residing or working in the project area to excessive noise levels?

The project site is not located within 2 miles of a public airport or a public use airport. The nearest airports to the project site are the Calexico International Airport located approximately 10 miles west of the project site and Holtville Airport located approximately 10 miles north of the project site. According to the Imperial County Airports Department, the Holtville Airport is currently closed. The Imperial County Airport Land Use Commission has established a set of land use compatibility criteria for lands surrounding the airports in Imperial County in the Imperial County Airport Land Use Compatibility Plan (ALUCP) (County of Imperial 1996). According to Figure 4G of the ALUCP, the project site is outside of the noise contours of the Calexico International Airport. Therefore, the project would not expose people residing or working in the project area to excessive noise levels and no impact would occur.

Mitigation Measure(s)

No mitigation measures are required.

3.12.4 Decommissioning/Restoration and Residual Impacts

Decommissioning/Restoration

Decommissioning or restoration of the solar facility would use similar equipment to what was evaluated in the construction noise and vibration analysis. Adhering to Imperial County standards for construction noise levels would reduce the noise and vibration impacts to below a level of significance.

Residual

Adhering to the Imperial County standards for construction noise levels would reduce the noise and vibration impacts to below a level of significance.

This page is intentionally blank.

3.13 Transportation

This section addresses the proposed project's impacts on traffic and the surrounding roadway network associated with construction and operation of the proposed project. The following discussion describes the existing conditions in the surrounding area, the existing federal, state, and local regulations regarding transportation, and an analysis of the potential impacts of the proposed project.

Information in this section is summarized from the Traffic Impact Study prepared by KOA. This report is included in Appendix K of this EIR.

3.13.1 Existing Conditions

Traffic Study Area

Intersections

The traffic study area for the proposed project includes the following intersections:

1. Site driveway and SR-98
2. Bonds Corner Road and SR-98
3. SR-98 and SR-7
4. SR-7 and Heber Road
5. SR-7 and south ramp
6. SR-7 and north ramp

Roadway Segments

The traffic study area for the proposed project includes the following roadway segments:

1. SR-98 from the project to the east
2. SR-98 from the project to Bonds Corner Road
3. SR-98 from Bonds Corner Road to SR-7
4. SR-7 from SR-98 to I-8
5. I-8 from SR-7 to SR-111

Existing Level of Service

Level of service (LOS) is a professional industry standard by which the operating conditions of a given roadway segment or intersection are measured. LOS ranges from A through F, where LOS A represents the best operating conditions and LOS F represents the worst operating conditions. LOS A facilities are characterized as having free flowing traffic conditions with no restrictions on maneuvering or operating speeds; traffic volumes are low and travel speeds are high. LOS F facilities are characterized as having forced flow with many stoppages and low operating needs.

Freeway Segments

The freeway segment (I-8 from SR-7 to SR-11) currently operates at acceptable LOS B in both directions under existing conditions.

Roadway Segments

All of the study area roadway segments analyzed currently operate at acceptable LOS A under existing conditions.

Intersections

All of the study area intersections analyzed currently operate at acceptable LOS B or better during the AM and PM peak hours under existing conditions.

Alternative/Public Transportation

Fixed Route Transportation

Imperial Valley Transit (IVT) is an inter-city fixed route bus system, subsidized by the Imperial Valley Association of Governments (IVAG), administered by the County Department of Public Works and operated by a public transit bus service. The service is wheelchair accessible and Americans with Disabilities Act compliant. IVT Routes are defined categorized in the following manner:

- **Fixed Routes.** Fixed routes operate over a set pattern of travel and with a published schedule. The fixed route provides a low cost, reliable, accessible and comfortable way to travel.
- **Deviated Fixed Route.** In several service areas, IVT operates on a deviated fixed route basis so that persons with disabilities and limited mobility are able to travel on the bus. Passengers must call and request this service the day before service is desired in the communities of Seeley, Ocotillo, and the east side of the Salton Sea.
- **Remote Zone Routes.** Remote zone routes operate once a week. These routes are "lifeline" in nature in that they provide connections from some of the more distant communities in the Imperial County area (IVT 2021).

The project site is not within the Fixed Route Transportation system and, therefore, would not receive regular bus service to the project site or within the vicinity of the project site. The nearest IVT bus stop is the 32D (Calexico to Brawley) bus stop on the southwest corner of Pauling Avenue and 3rd Street in the City of Calexico, which is approximately 10 miles west of the project site.

Bicycle Facilities

The project site is located within a rural portion of Imperial County. There are no bicycle facilities in the immediate proximity of the project site. There are no planned bike routes in immediate proximity to the project site.

Project Site Access

The project site is located within an unincorporated area of Imperial County, approximately 10 miles east of the City of Calexico. The triangular project site is somewhat isolated in that the All-American Canal and U.S./Mexico Border make up the northern and southern boundaries of the site. Vehicular access to the site is currently provided via an existing driveway along SR 98, just east of the project site.

3.13.2 Regulatory Setting

This section identifies and summarizes laws, policies, and regulations that are applicable to the proposed project.

State

California Department of Transportation

Caltrans manages more than 50,000 miles of California's highway and freeway lanes, provides inter-city rail services, permits more than 400 public-use airports and special-use hospital heliports, and works with local agencies. Specifically, Caltrans is responsible for the design, construction, maintenance, and operation of the California State Highway System.

As it relates to the proposed project and potential construction access routes within the County, Caltrans District 11 is responsible for maintaining and managing I-8, SR-98, and SR-7.

Regional

SCAG 2020-2045 RTP/SCS (Connect SoCal)

On September 3, 2020, SCAG adopted the 2020-2045 RTP/SCS (SCAG 2020). The RTP/SCS is a long-range visioning plan that balances future mobility and housing needs with economic, environmental and public health goals. Input from local governments, county transportation commissions, tribal governments, non-profit organizations, businesses, and local stakeholders within the counties of Imperial, Los Angeles, Orange, Riverside, San Bernardino, and Ventura. The 2020-2045 RTP/SCS demonstrates how the region will reduce emissions from transportation sources to comply with SB 375 and meet the NAAQS set forth by the Clean Air Act.

The updated RTP/SCS contains thousands of individual transportation projects that aim to improve the region's mobility and air quality and revitalize the economy. Since the RTP/SCS's adoption, the county transportation commissions have identified new project priorities and have experienced technical changes that are time-sensitive. Additionally, the new amendments for the plan have outlined minor modifications to project scopes, costs and/or funding and updates to completion years. The amendments to the RTP/SCS do not change any other policies, programs, or projects in the plan.

Local

County of Imperial Circulation and Scenic Highways Element

The Circulation and Scenic Highways Element identifies the location and extent of transportation routes and facilities. It is intended to meet the transportation needs of local residents and businesses and as a source for regional coordination. The inclusion of Scenic Highways provides a means of protecting and enhancing scenic resources within highway corridors in Imperial County. The purpose of the Circulation and Scenic Highways Element is to provide a comprehensive document which contains the latest knowledge about the transportation needs of the County and the various modes available to meet these needs. Additionally, the purpose of this Element is to provide a means of protecting and enhancing scenic resources within both rural and urban scenic highway corridors.

Coordination across jurisdictional standards for road classification and design standards was identified as a crucial component to the 2008 update of the Circulation and Scenic Highways Element. The intent

of this element is to provide a system of roads and streets that operate at a LOS “C” or better (County of Imperial 2008).

3.13.3 Impacts and Mitigation Measures

Thresholds of Significance

Based on CEQA Guidelines Appendix G, project impacts related to transportation and traffic are considered significant if any of the following occur:

- Conflict with a program plan, ordinance or policy addressing the circulation system, including transit, roadway, bicycle and pedestrian facilities
- Conflict with or be inconsistent with CEQA Guidelines section 15064.3, subdivision (b)
- Substantially increase hazards due to a geometric design feature (e.g., sharp curves or dangerous intersections) or incompatible uses (e.g., farm equipment)
- Result in inadequate emergency access

Methodology

County of Imperial

ROADWAY SEGMENT LEVEL OF SERVICE STANDARDS

The County of Imperial does not have published significance criteria for traffic impacts. However, the Circulation and Scenic Highways Element of the County General Plan does state that the LOS goal for intersections and roadway segments is to operate at LOS C or better. Therefore, if an intersection or segment degrades from LOS C or better to LOS D or worse with the addition of project traffic, the impact is considered significant. Furthermore, a project may result in a significant impact on Caltrans facilities if the new project traffic has decreased the operations of surrounding roadways and intersections by a defined threshold.

PEAK HOUR INTERSECTION LEVEL OF SERVICE STANDARDS

A project is considered to have a significant impact on Caltrans facilities if the project traffic has decreased the operations of surrounding roadways by a defined threshold. The Traffic Impact Study (Appendix K of this EIR) used principles of the specific analysis methods contained in the 2010 Highway Capacity Manual to analyze traffic conditions on roadway facilities. The analysis of peak hour intersection conditions was conducted using the Synchro 10 software program developed by Trafficware. Table 3.13-1 summarizes the LOS criteria for signalized and unsignalized intersections.

The County of Imperial traffic impact study guidelines consider LOS C or better during the AM and PM peak hours to be the threshold of significance for intersection LOS. Therefore, if the proposed project exceeds the County’s LOS C threshold for surrounding roadways intersections then the proposed project may have a significant project impact.



Table 3.13-1. HCM Level of Service Thresholds for Intersections

LOS	Signalized Intersection Delay (Seconds/Vehicle)	Unsignalized Intersection Average Stop Delay (Seconds/Vehicle)
A	0.0 ≤ 10.0	0.0 ≤ 10.0
B	10.1 to 20.0	10.1 to 15.0
C	20.1 to 35.0	15.1 to 25.0
D	35.1 to 55.0	25.1 to 35.0
E	55.1 to 80.0	35.1 to 50.0
F	≥ 80.0	≥ 50.0

Source: Appendix K of this EIR LOS – level of service

California Department of Transportation

Freeway LOS analysis is based upon procedures developed by Caltrans. The corresponding LOS listed in Table 3.13-2 represents an approximation of freeway operating conditions in the peak direction of travel during the peak hour. Constant with Caltrans requirements, LOS D or better is used as the threshold for acceptable freeway operations.

Therefore, if the proposed project results in impacts that would degrade the LOS of I-8, SR-98, and SR-7 to LOS E or F, then the proposed project would exceed LOS thresholds as set forth by the County and Caltrans and may have a significant project impact. A feasible mitigation measure will need to be identified to return the impact within the thresholds (pre-project + allowable increase) or the impact will be considered significant and unmitigated.

Table 3.13-2. Caltrans Freeway Segment Level of Service Definitions

LOS	Maximum Volume/Capacity	Congestion/Delay	Traffic Description
A	0.0 ≤ 0.30	None	Free flow.
B	> 0.30 to 50.0	None	Free to stable flow, light to moderate volumes.
C	> 50.0 to 0.71	None to Minimal	Stable flow, moderate volumes, freedom to maneuver noticeably restricted.
D	> 0.71 to 0.89	Minimal to Substantial	Approaches unstable flow, heavy volumes, very limited freedom to maneuver.
E	> 0.89 to 1.00	Significant	Extremely unstable flow, maneuverability and psychological comfort extremely poor.
F	>1.00	Considerable	Forced or breakdown flow. Delay measured in average travel speed (miles per hour [MPH]). Signalized segments experiences delays > 60.0 seconds/vehicle.

Source: Appendix K of this EIR LOS = level of service

Project Trip Generation

The proposed project will generate the most traffic during construction. The construction vehicle mix for both on-road and off-road equipment (e.g., dozers, loaders, excavators), by each phase of construction, is presented in Attachment A of the *Air Quality and Greenhouse Gas Assessment* prepared for the proposed project (Appendix C of this EIR).

The construction of the project is estimated to take 12-18 months and would begin in late 2022 and/or 2023. The number of on-site construction workers for the solar project facility is not expected to exceed 150 workers at any one time. The number of on-site construction workers for the battery storage facility and the substation is not expected to exceed 100 workers at any one time. The trip generation was estimated if the construction phases were to overlap, so both are included. Delivery trucks are expected to follow the same routes as the construction workers. An estimated two trucks would arrive at the project site each day during the first few weeks of construction of the solar generating facility. Truck trips have been converted into passenger equivalent volumes (PCE) using a PCE factor of 2.5.

Table 3.13-3 provides the estimated average daily on-road project trip generation (i.e., trips to and from the site) for the construction phases of the proposed project. As shown, the maximum number of on-road trips during construction would be approximately 520 daily trips ends (500 worker trips and 20 construction truck trips).

The proposed project requires minimal operations and maintenance activities and would not require presence of full-time employees. However, it is conservatively assumed that for day-to-day inspection and minor maintenance, some employees would commute to the project site. The annual operations are assumed to be as follows:

- For site inspection and minor repairs, up to 3 one-way worker trips per day would be generated.
- Routine maintenance activities would include panel washing, which is expected to occur two times annually.
- Periodic (approximately every 3 months) removal of vegetation manually and/or by treatment with herbicides.

Table 3.13-3. Construction Phase Trip Generation

Construction Phase (Duration)	Intensity (Unit)	Daily Rate	Daily Trip
Solar Construction Workers	150 (Employees)	2	300
Batter Storage Workers	150 (Employees)	2	200
Equipment Deliveries and Construction Truck Trips (PCE)	8 (trucks)	2.5	20
Total Daily Trips			520

Source: Appendix K of this EIR PCE = passenger equivalent volumes

Impact Analysis

Impact 3.13-1 Would the project conflict with a program plan, ordinance or policy addressing the circulation system, including transit, roadway, bicycle and pedestrian facilities?

During the construction phase of the proposed project, the maximum number of trip ends generated on a daily basis would be approximately 520 trips. Under construction year conditions with and without the proposed project, all roadway segments analyzed would operate at LOS A, all intersections would operate at a LOS B or better during both AM and PM peak hours, and all freeway segments would operate at LOS B or better during both AM and PM peak hours.

Implementation of the proposed project would not require any public road widening to accommodate vehicular trips associated with the proposed project (construction phase and operational phase), while maintaining adequate LOS. Additionally, future operations and maintenance would be conducted remotely, with minimal trips to the project site for panel washing and other solar maintenance. There is no regular bus service to the general area and project-related construction and operations and maintenance phases would not impact mass transit. The proposed project would not interfere with bicycle facilities because the proposed project is located in a rural portion of the County with no existing or potential future designated bike routes in the area. Therefore, the proposed project would not result in any significant impacts to any roadway segments or transportation related facilities/infrastructure within the project area during construction and operation; and would not conflict with a program plan, ordinance, or policy as it relates to traffic and transportation. Impacts are considered less than significant.

Mitigation Measure(s)

No mitigation measures are required.

Impact 3.13-2 Would the project conflict with or be inconsistent with CEQA Guidelines section 15064.3, subdivision (b)?

Section 15064.3(b) of the CEQA Guidelines provides guidance on determining the significance of transportation impacts and focuses on the use of vehicle miles traveled (VMT), which is defined as the amount and distance of automobile travel associated with a project. The Natural Resources Agency (NRA) has adopted guidance to incorporate SB 743 into CEQA analysis. The NRA's Technical Advisory on Evaluating Transportation Impacts in CEQA (NRA 2018), includes screening thresholds for small projects. Absent substantial evidence indicating that a project would generate a potentially significant level of VMT, or inconsistency with a Sustainable Communities Strategy (SCS) or general plan, projects that generate or attract fewer than 110 trips per day generally may be assumed to cause a less-than-significant transportation impact.

Although the proposed project would increase VMT during the construction phase as a result of trips made by construction workers and transportation of construction material and equipment, these increases are temporary in nature and would cease once construction is complete. Upon operation, the proposed project would only require intermittent maintenance (including inspection, panel washing, and vegetation removal), which would result in nominal (less than 10) daily vehicle trips. Therefore, the proposed project would not conflict or be inconsistent with Section 15064.3(b) of the CEQA Guidelines and this impact is considered less than significant.

Mitigation Measure(s)

No mitigation measures are required.

Impact 3.13-3 Would the project substantially increase hazards due to a geometric design feature (e.g., sharp curves or dangerous intersections) or incompatible uses (e.g., farm equipment)?

The project is a solar infrastructure project that would occur on privately-owned land located in a rural area. To accommodate emergency access, PV panels would be spaced to maintain proper clearance. Internal access roads, up to 30-feet wide, would be constructed along the perimeter fence and solar panels to facilitate vehicle access and maneuverability for emergency unit vehicles. Access roads would be graded and compacted (native soils) as required for construction, operations, maintenance, and emergency vehicle access. Additionally, any proposed haul routes would be submitted to the County for approval prior to construction. Therefore, the project would not substantially increase hazards due to a geometric design feature (e.g., sharp curves or dangerous intersections) or incompatible uses (e.g., farm equipment). Impacts are considered less than significant.

Mitigation Measure(s)

No mitigation measures are required.

Impact 3.13-4 Would the project result in inadequate emergency access?

Vehicular access to the project site is currently provided via an existing driveway along SR-98. Under the proposed project, vehicular access for workers would continue to be provided via the existing driveway as the project would not require additional storage lanes or lengths along SR-98. Following discussions with the Imperial Irrigation District, it was determined heavy construction vehicles would cross the All-American Canal at Gordon Wells Road located approximately 20 miles east of the project site (Figure 3.13-1). Access for heavy construction vehicles to and from the project site requires crossing the All-American Canal, via two existing bridges (Figure 3.13-2), located along Gordon Wells Road. Gordon Wells Road has an interchange with I-8. The bridges over the canal were constructed in 2009. The bridges are rated as open with no restrictions and have a “Good” condition rating.

As previously stated, PV panels would be spaced to maintain proper clearance for emergency access. Internal access roads, up to 30-feet wide, would be constructed along the perimeter fence and solar panels to facilitate vehicle access and maneuverability for emergency unit vehicles. Access roads would be graded and compacted (native soils) as required for construction, operations, maintenance, and emergency vehicle access. The access and service roads would also have turnaround areas at any dead-end to allow clearance for fire trucks per fire department standards. The access and service roads would also have turnaround areas at any dead-end to allow clearance for fire trucks per fire department standards. Therefore, the project would not result in inadequate emergency access and impacts are considered less than significant.

Mitigation Measure(s)

No mitigation measures are required.

3.13.4 Decommissioning/Restoration and Residual Impacts

Decommissioning/Restoration

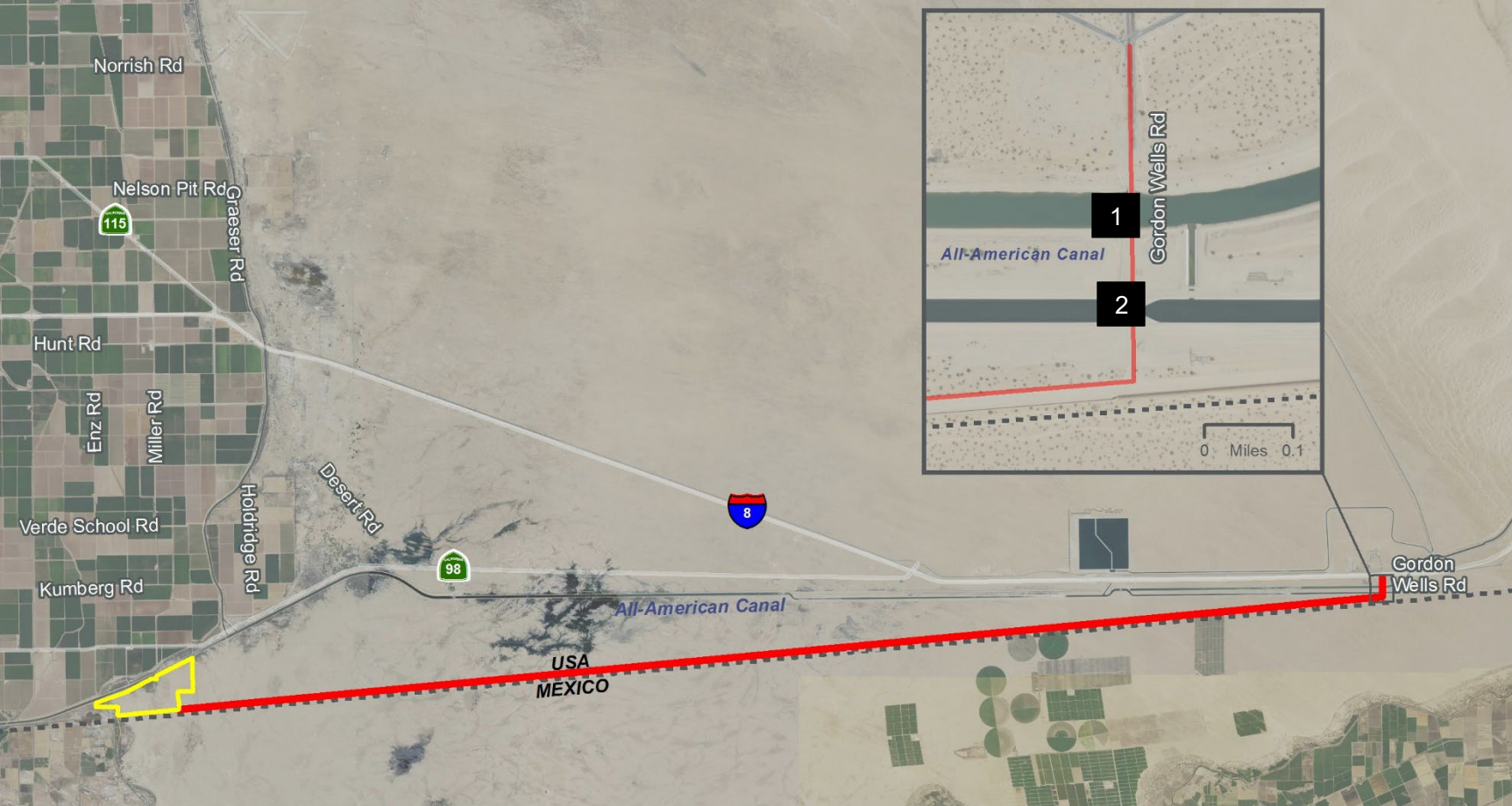
This section included an analysis of construction traffic for the proposed project. As presented above, construction traffic would not result in a significant impact on any of the project area roadway segments, intersections, and freeway segments because of the low volume of traffic. A similar scenario would occur during the decommissioning and site restoration stage for the proposed project. ADT would be similar to or less than the ADT required for construction. Similarly, the decommissioning activities would not result in a significant impact related to possible safety hazards, or possible conflicts with adopted policies, plans, or programs as the decommissioning and subsequent restoration would revert the project site to pre-project conditions. Therefore, decommissioning and restoration of the project site would not generate traffic resulting in a significant impact on the circulation network. A less than significant impact is identified, and no mitigation is required.

Residual

The construction and operation of the proposed project would not result in direct impacts on intersections, roadway segments, and freeway segments. Therefore, less than significant impacts have been identified. No mitigation is required, and no residual unmitigated impacts would occur with implementation of the proposed project.

This page is intentionally blank.

Figure 3.13-1. Proposed Heavy Construction Equipment Access



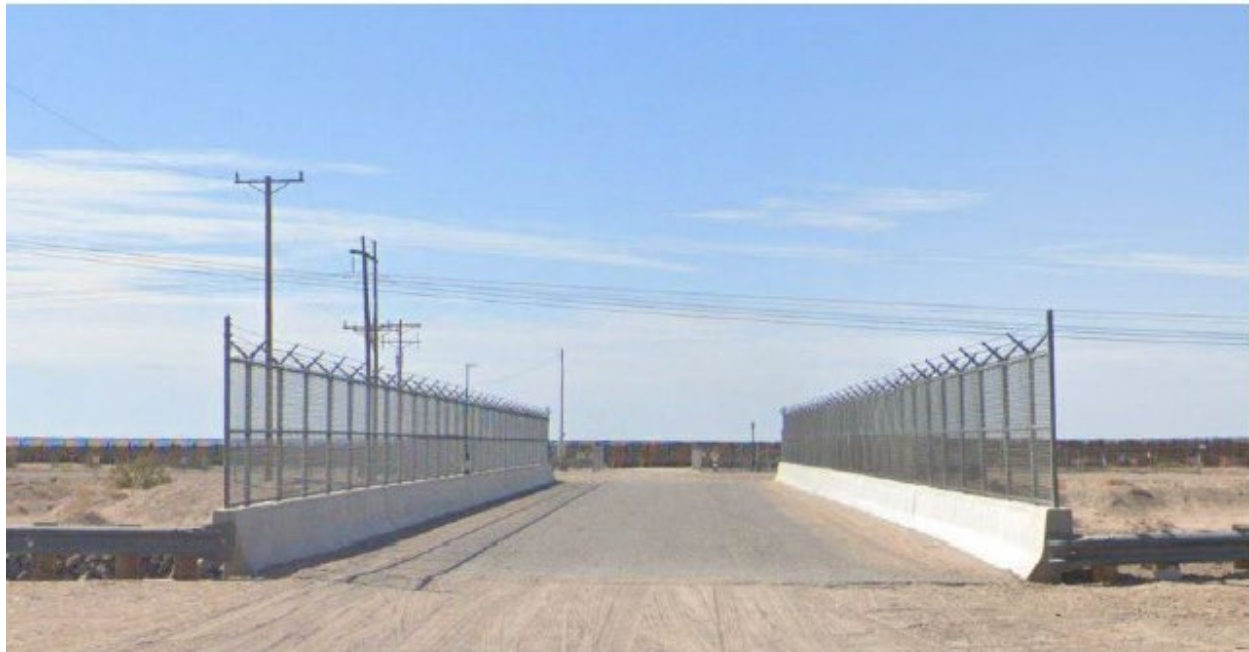
Legend

- Proposed Heavy Construction Equipment Access
- Project Location
- # Bridge Crossing Locations – see Figure 3.13-2 for photos



This page is intentionally blank.

Figure 3.13-2. Proposed Bridge Crossings over All-American Canal



Bridge over north American Canal



Bridge over south American Canal

This page is intentionally blank.

3.14 Tribal Cultural Resources

This section discusses tribal cultural resources that may be potentially impacted by the proposed project. The following identifies if there are any existing tribal cultural resources within the project site, analyzes potential impacts of the proposed project, and recommends mitigation measures to avoid or reduce potential impacts of the proposed project. Information for this section is summarized from the Cultural Resources Inventory prepared by ECORP Consulting, Inc. This report is included in Appendix F of this EIR.

3.14.1 Existing Conditions

Tribal Cultural Setting

See Section 3.6, Cultural Resources of this EIR, for description of the regional ethnohistory.

Records Search

A records search from the SCIC of the CHRIS at San Diego State University was requested on September 15, 2020, to determine the extent of previous surveys within a 1-mile of the project area, and whether previously documented pre-contact or historic-period archaeological sites, architectural resources, or traditional cultural properties exist within the area.

As discussed in Section 3.6, Cultural Resources, because previous surveys took place more than 19 years ago, a resurvey of the project area was conducted and found 6 previously recorded cultural resources within 1-mile of the project area. Previously recorded resources comprise two historic-period canals, one historic-period bridge, one international boundary monument, one multicomponent precontact ceramic scatter/historic-period refuse deposit, and one pre-contact temporary camp with habitation debris. One previously recorded resource, an historic-period refuse deposit, is located within the project area.

Sacred Lands File Results

The California Native American Heritage Commission (NAHC) identifies, catalogs, and protects Native American cultural resources on private and public lands in California. Cultural resources include graves, cemeteries, and places of special religious or social significance to Native Americans. The NAHC also records the historical territories of state recognized tribes into a database called the Sacred Lands File. A records search of the Sacred Lands File is conducted to ensure that the tribes potentially affected by a project are properly notified and consulted.

A Sacred Land Files (SLF) search request was submitted on September 15, 2020, to the California NAHC and the search results were received on September 29, 2020. The search of the SLF was negative and failed to indicate the presence of Native American cultural resources in the project area.

3.14.2 Regulatory Setting

This section identifies and summarizes federal, state, and local laws, policies, and regulations that are applicable to the project.

Federal

Native American Graves Protection and Repatriation Act (1990); Title 25, United States Code Section 3001, et seq.

The Native American Graves Protection and Repatriation Act defines “cultural items,” “sacred objects,” and “objects of cultural patrimony;” establishes an ownership hierarchy; provides for review; allows excavation of human remains but stipulates return of the remains according to ownership; sets penalties; calls for inventories; and provides for the return of specified cultural items.

State

Assembly Bill 52

AB 52 amends PRC 5097.94 and adds eight new sections to the PRC relating to Native Americans. AB 52 was passed in 2014 and took effect on July 1, 2015. It establishes a new category of environmental impacts that must be considered under CEQA called tribal cultural resources (PRC 21074) and establishes a process for consulting with Native American tribes and groups regarding potential impacts to tribal resources. Under AB 52, a project that may substantially change the significance of a tribal cultural resource is a project that may have a significant impact on the environment. If a project may cause a significant impact on a tribal cultural resource, the lead agency shall implement measures to avoid the impacts when feasible.

Assembly Bill 2641

AB 2641 requires that upon discover of Native American remains, reasonable protection measures should be taken to protect the discovery from disturbance and the NAHC-designated Most Likely Descendent (MLD) shall be identified. The MLD shall be granted access to the site and given 48 hours to conduct a site inspection and make treatment recommendations. The concerned parties may extend discussions beyond the initial 48 hours to allow for the discovery of additional remains. AB 2641(e) includes a list of site protection measures and states that the landowner shall comply with one or more of the following:

- (1) Record the site with the NAHC or the appropriate Information Center.
- (2) Utilize an open-space or conservation zoning designation or easement.
- (3) Record a document with the county in which the property is located.

Assembly Bill 4239

AB 4239, passed in 1976, established the NAHC as the primary government agency responsible for identifying and cataloging Native American cultural resources. The bill authorized the Commission to act in order to prevent damage to and insure Native American access to sacred sites and authorized the Commission to prepare an inventory of Native American sacred sites located on public lands.

Public Resources Code Section 21074

PRC Section 21074 defines a tribal cultural resource as a site, feature, place, cultural landscape, sacred place, and any object with cultural value to a California Native American Tribe. A tribal cultural resource must be on or eligible for the CRHR or must be included in a local register of historical resources. The lead agency can determine if a tribal cultural resource is significant even if it has not been evaluated for the CRHR or is not included on a local register.

Public Resources Code 5097.97

No public agency and no private party using or occupying public property or operating on public property under a public license, permit, grant, lease, or contract made on or after July 1, 1977, shall in any manner whatsoever interfere with the free expression or exercise of Native American religion as provided in the U.S. Constitution and the California Constitution; nor shall any such agency or party cause severe or irreparable damage to any Native American sanctified cemetery, place of worship, religious or ceremonial site, or sacred shrine located on public property, except on a clear and convincing showing that the public interest and necessity so require.

Public Resources Code 5097.98 (b) and (e)

As amended by AB 2641, PRC 5097.98 (b) and (e) require a landowner on whose property Native American human remains are found to limit further development activity in the vicinity until he/she confers with the NAHC-identified most likely descendants (MLD) to consider treatment options. In the absence of MLDs or of a treatment acceptable to all parties, the landowner is required to reenter the remains elsewhere on the property in a location not subject to further disturbance.

California Health and Safety Code, Section 7050.5

California HSC 7050.5 makes it a misdemeanor to disturb or remove human remains found outside a cemetery. This code also requires a project owner to halt construction if human remains are discovered and to contact the County Coroner.

Local

Imperial County General Plan

The Imperial County General Plan provides goals, objectives, and policies for the identification and protection of significant cultural resources. The Conservation and Open Space Element of the General Plan includes goals, objectives, and policies for the protection of cultural resources and scientific sites that emphasize identification, documentation, and protection of cultural resources. While Section 3.11, Land Use Planning, of this EIR analyzes the proposed project's consistency with the General Plan pursuant to CEQA Guidelines Section 15125(d), the Imperial County Board of Supervisors and Planning Commission ultimately make a determination as to the project's consistency with the General Plan. Goals and Objectives applicable to the proposed project are summarized in Table 3.14-1.

Table 3.14-1. Project Consistency with Applicable General Plan Goals and Objectives

General Plan Policies	Consistency with General Plan	Analysis
<p>Conservation and Open Space Element - Open Space and Recreation Conservation</p> <p>Goal 1 - Environmental resources shall be conserved for future generations by minimizing environmental impacts in all land use decisions and educating the public on their value.</p> <p>Objective 1.4 - Ensure the conservation and management of the County's natural and cultural resources.</p>	Consistent	<p>A Cultural Resources Inventory was prepared for the proposed project. Based on the SLF search, there are no known tribal cultural resources within the project area. However, as discussed below, the proposed project has the potential to encounter undocumented tribal cultural resources and Native American human remains.</p> <p>Implementation of Mitigation Measures CR-2 and CR-3 would reduce potentially significant impacts on unknown historic or unique archaeological materials during construction of the project site. Implementation of Mitigation Measure CR-4 would reduce potential impacts on human remains to a level less than significant.</p>
<p>Objective 3.1 - Protect and preserve sites of archaeological, ecological, historical, and scientific value, and/or cultural significance.</p>	Consistent	

Source: County of Imperial 1993; Appendix F of this EIR

Notes:

CR=cultural resource

3.14.3 Impacts and Mitigation Measures

This section presents the significance criteria used for considering project impacts related to tribal cultural resources, the methodology employed for the evaluation, an impact evaluation, and mitigation requirements, if necessary.

Thresholds of Significance

Based on CEQA Guidelines Appendix G, project impacts related to tribal cultural resources are considered significant if the project causes a substantial adverse change in the significance of a tribal cultural resource defined in PRC section 21074 as either a site, feature, place, cultural landscape that is geographically defined in terms of the size and scope of the landscape, sacred place, or object with cultural value to a California Native American tribe, and that is:

- Listed or eligible for listing in the CRHR, or in a local register of historical resources as defined in PRC section 5020.1(k)
- A resource determined by the lead agency, in its discretion and supported by substantial evidence, to be significant pursuant to criteria set forth in subdivision (c) of PRC Section 5024.1. In applying the criteria set forth in subdivision (c) of PRC Section 5024.1, the lead agency shall consider the significance of the resource to a California Native American tribe

Methodology

This analysis evaluates the potential for the proposed project, as described in Chapter 2, Project Description, to interact with tribal cultural resources in the project site. Based on the extent of these interactions, this analysis considers whether these conditions would result in an exceedance of one or more of the applied significance criteria as identified above.

As indicated in the environmental setting, a Cultural Resources Inventory (Appendix F of this EIR) was prepared for the proposed project. The cultural resources inventory provides the results of a SCIC records search, a SLF search conducted by the NAHC, and field survey, which have been completed for the project site pursuant to CEQA.

This report is included in Appendix F of this EIR. The information from the cultural resources inventory was reviewed and summarized to present the existing conditions and to identify potential environmental impacts, based on the significance criteria presented in this section. Impacts associated with tribal cultural resources that could result from project construction and operational activities were evaluated qualitatively based on site conditions; expected construction practices; materials, locations, and duration of project construction and related activities.

Impact Analysis

Impact 3.14-1 *Would the project cause a substantial adverse change in the significance of a tribal cultural resource defined in Public Resources Code section 21074 as either a site, feature, place, cultural landscape that is geographically defined in terms of the size and scope of the landscape, sacred place, or object with cultural value to a California Native American tribe, and that is:*

Listed or eligible for listing in the California Register of Historical Resources, or in a local register of historical resources as defined in Public Resources Code section 5020.1(k)

A resource determined by the lead agency, in its discretion and supported by substantial evidence, to be significant pursuant to criteria set forth in subdivision (c) of Public Resources Code Section 5024.1. In applying the criteria set forth in subdivision (c) of Public Resources Code Section 5024.1, the lead agency shall consider the significance of the resource to a California Native American tribe?

The NAHC maintains the confidential SLF which contains sites of traditional, cultural, or religious value to the Native American community. A SLF search request was submitted on September 15, 2020 to the California NAHC and the search results were received on September 29, 2020. The search of the SLF was negative and failed to indicate the presence of Native American cultural resources in the project area. AB 52 requires a lead agency to begin consultation with a California Native American Tribe that is traditionally and culturally affiliated with the geographic areas of the proposed project. In accordance with AB 52, the County provided notification of the proposed project to Native American tribes that the County understands to be traditionally and culturally affiliated with the geographic area of the proposed project. This notification was provided in a letter sent via certified mail on March 26, 2021 to the Quechan Indian Tribe. On April 1, 2021, the Quechan Indian Tribe requested consultation with the County on the proposed project. The County is in the process of consulting with the Quechan Indian Tribe and has requested that they provide any information regarding any Traditional Cultural Properties, Sacred Sites, resource collecting areas, or any other areas of concern known to occur in the project area.

To date, no tribes have indicated the potential for traditional cultural properties or sacred sites. Therefore, the project is not anticipated to cause a substantial adverse change in the significance of a tribal cultural resource, defined in PRC section 21074 as either a site, feature, place, cultural landscape that is geographically defined in terms of the size and scope of the landscape, sacred place, or object with cultural value to a California Native American tribe, and that is a resource determined by the lead agency, in its discretion and supported by substantial evidence, to be significant pursuant to criteria set forth in subdivision (c) of PRC Section 5024.1, and, per the criteria set forth in Section 5024.1, considering the significance of the resource to a California Native American tribe. As stated in Section 3.6 Cultural Resources, potential impacts to archaeological resources would be less than significant with implementation of Mitigation Measure CR-2. Impacts specifically related to tribal cultural resources would be less than significant.

Mitigation Measure(s)

No mitigation measures are required.

3.14.4 Decommissioning/Restoration and Residual Impacts

Decommissioning/Restoration

If at the end of the PPA term, no contract extension is available for a power purchaser, no other buyer of the energy emerges, or there is no further funding of the project, the project will be decommissioned and dismantled. No impact is anticipated from restoration activities as the ground disturbance and associated impacts on tribal cultural resources will have occurred during the construction phase of the proposed project.

Residual

No unmitigable impacts on cultural resources would occur with implementation of the proposed project.

3.15 Utilities and Service Systems

This section includes an evaluation of potential impacts for identified Utilities/Service Systems that could result from implementation of the project. Utilities/Service Systems include wastewater treatment facilities, stormwater drainage facilities, water supply and treatment, and solid waste disposal. The impact analysis provides an evaluation of potential impacts to Utilities/Service Systems based on criteria derived from CEQA Guidelines in conjunction with actions proposed in Chapter 2, Project Description. A *Water Supply Assessment* (WSA) was prepared for the VEGA SES 4 Solar Energy Project. This report is included in Appendix L of this EIR.

The IS/NOP prepared for this EIR determined that impacts with regards to solid waste disposal, storm drainage, and wastewater treatment would be less than significant. Therefore, these impacts are not addressed in detail in this EIR; however, the rationale for eliminating these issues is discussed in Chapter 6.0, Effects Found Not Significant.

3.15.1 Existing Conditions

The Imperial Valley area is located within the south-central part of Imperial County and is bound by Mexico on the south, the Algodones Sand Hills on the east, the Salton Sea on the north and San Diego County on the northwest, and the alluvial fans bordering the Coyote Mountains and the Yuha Desert to the southwest. Imperial Valley depends on the Colorado River for its water, which the Imperial Irrigation District (IID) transports, untreated, to delivery gates for agricultural, municipal, industrial (including geothermal and solar energy), environmental (managed marsh), recreational (lakes), and other non-agricultural uses. IID supplies the cities, communities, institutions and Golden State Water (which includes all or portions Calipatria, Niland, and some adjacent Imperial County territory) with untreated water that they treat to meet state and federal drinking water guidelines before distribution to their customers (Appendix L of this EIR).

Although the project site is currently vacant land and does not currently receive water from IID, the project site is located within IID's Imperial Unit and district boundary and as such is eligible to receive water service. IID has adopted an Interim Water Supply Policy (IWSP) for Non-Agricultural Projects, from which water supplies can be contracted to serve new developments within IID's water service area. The IWSP sets aside 25,000 acre-feet annually (AFY) of IID's Colorado River water supply to serve new non-agricultural projects. As of April 2021, a balance of 23,800 acre-feet per year (AFY) remain available under the IWSP for new non-agricultural projects ensuring reasonably sufficient supplies for such projects (Appendix L of this EIR).

3.15.2 Regulatory Setting

This section identifies and summarizes laws, policies, and regulations that are applicable to the proposed project.

State

Senate Bill 610

With the introduction of SB 610, any project under CEQA shall provide a WSA if:

- The project meets the definition of the Water Code Section 10912:

For the purposes of this part, the following terms have the following meanings:

(a) “Project” means any of the following:

- (1) A proposed residential development of more than 500 dwelling units.
- (2) A proposed shopping center or business establishment employing more than 1,000 persons or having more than 500,000 square feet of floor space.
- (3) A proposed commercial office building employing more than 1,000 persons or having more than 250,000 square feet of floor space.
- (4) A proposed hotel or motel, or both, having more than 500 rooms.
- (5) A proposed industrial, manufacturing, or processing plant, or industrial park planned to house more than 1,000 persons, occupying more than 40 acres of land, or having more than 650,000 square feet of floor area.
- (6) A mixed-use project that includes one or more of the projects specified in this subdivision.
- (7) A project that would demand an amount of water equivalent to, or greater than, the amount of water required by a 500 dwelling unit project.

(b) If a public water system has fewer than 5,000 service connections, then “project” means any proposed residential, business, commercial, hotel or motel, or industrial development that would account for an increase of 10 percent or more in the number of the public water system’s existing service connections, or a mixed-use project that would demand an amount of water equivalent to, or greater than, the amount of water required by residential development that would represent an increase of 10 percent or more in the number of the public water system’s existing service connections.

After review of Water Code Section 10912, the solar facility is deemed a “project” because it is a proposed industrial use occupying more than 40 acres of land.

California Water Code

Water Code Sections 10656 and 10657 restrict state funding for agencies that fail to submit their urban water management plan to the Department of Water Resources. In addition, Water Code Section 10910 describes the WSA that must be undertaken for projects referred under PRC Section 21151.9, including an analysis of groundwater supplies. Water agencies are given 90 days from the start of consultation in which to provide a WSA to the CEQA lead agency. Water Code Section 10910 also specifies the circumstances under which a project for which a WSA was once prepared would be required to obtain another assessment. Water Code Section 10631 directs that contents of the urban water management plans include further information on future water supply projects and programs and groundwater supplies.

Water Quality Control Plan for the Colorado River Basin

The Water Quality Control Plan for the Colorado River Basin (or Basin Plan) prepared by the Colorado River RWQCB (Region 7) identifies beneficial uses of surface waters within the Colorado River Basin region, establishes quantitative and qualitative water quality objectives for protection of beneficial uses, and establishes policies to guide the implementation of these water quality objectives.

Local

Imperial Integrated Regional Water Management Plan

The Imperial Integrated Regional Water Management Plan (IRWMP) serves as the governing document for regional water planning to meet present and future water resource needs and demands by addressing such issues as additional water supply options, demand management and determination and prioritization of uses and classes of service provided. In November 2012, the Imperial County Board of Supervisors approved the Imperial IRWMP, and the City of Imperial City Council and the IID Board of Directors approved it in December 2012. Through the IRWMP process, IID presented to the region stakeholders options in the event long-term water supply augmentation is needed, such as water storage and banking, recycling of municipal wastewater, and desalination of brackish water.

Imperial Irrigation District Interim Water Supply Policy for Non-Agricultural Projects

The IWSP was adopted by the IID Board on September 29, 2009. The IWSP provides a mechanism to address water supply requests for projects being developed within the IID service area. The IWSP designates up to 25,000 AFY of IID's annual Colorado River water supply for new non-agricultural projects, provides a mechanism and process to develop a water supply agreement for any appropriately permitted project, and establishes a framework and set of fees to ensure the supplies used to meet new demands do not adversely affect existing users by funding water conservation or augmentation projects, as needed.

Depending on the nature, complexity, and water demands of the proposed project, new projects may be charged a one-time reservation fee and an annual water supply development fee for the contracted water volume used solely to assist in funding new water supply projects. All new industrial use projects are subject to the fee, while new municipal and mixed-use projects shall be subject to the fee if the project water demands exceed certain district-wide average per capita use standards. The applicability of the fee to mixed-use projects will be determined by IID on a case-by-case basis, depending on the proportion of types of land uses and water demand proposed for a project.

Temporary Land Conversion Following Policy

The Temporary Land Conversion Following Policy was adopted by the Board on October 28, 2013, to provide a mechanism for IID to administer apportionment of the district's quantified annual supply of Colorado River water; IID board approved a resolution repealing the Equitable Distribution Plan (EDP) on February 6, 2018.

In order to facilitate new development and economic diversity in Imperial County; as well as ensure that the long-term, temporary, land use designations are conducive to a coordinated land use/water supply policy as envisioned in the Imperial IRWMP the IID Temporary Land Conversion Following Policy was developed. This policy provides a framework for a temporary, long-term following program to work in concert with the IWSP and provides direction for certain private projects that, if implemented, will temporarily remove land from agricultural production within the district's water service area include renewable solar energy and other non-agricultural projects. Such projects may need a short-term water supply for construction and decommissioning activities and longer-term water service for facility operation and maintenance or for treating to potable water standards.

3.15.3 Impacts and Mitigation Measures

Thresholds of Significance

Based on CEQA Guidelines Appendix G, project impacts related to utilities and service systems are considered significant if any of the following occur:

Water Supply

- Have insufficient water supplies available to serve the project and reasonably foreseeable future development during normal, dry and multiple dry years

Methodology

The WSA (Appendix L of this EIR) was prepared using project-specific data to calculate the project's water consumption during construction and at build-out collectively ("operational").

Impact Analysis

Impact 3.15-1 Have sufficient water supplies available to serve the project and reasonably foreseeable future development during normal, dry and multiple dry years?

CONSTRUCTION

Water for construction would be obtained from IID canals or laterals in conformance with IID rules and regulations for municipal, commercial, and industrial (MCI) temporary water use. Water would be picked up from the All-American Canal and delivered to the construction location by a water truck capable of carrying approximately 4,000 gallons per load.

The proposed project is anticipated to take approximately 18 months from the commencement of the construction process to complete. Construction water needs would be limited to earthwork, soil conditioning, dust suppression, and compaction efforts. The proposed project would require approximately 183.3 AFY of water during construction.

OPERATIONS AND MAINTENANCE

The estimated annual water consumption for operation and maintenance of the proposed project, including periodic PV module washing, would be approximately 10 AFY, which would be trucked to the project site as needed. No full-time site personnel would be required on-site during operations and approximately two employees would only be onsite up to four times per year to wash the solar panels to ensure optimum solar absorption by removing dust particles and other buildup.

TOTAL AND ANNUAL WATER DEMAND

According to the WSA (Appendix L of this EIR), the anticipated water demand for construction and operation project is estimated to be 460 AF, for an annualized demand of 23 AFY for the 20-year project life.

WATER SUPPLY

Water for the project site will be supplied through an IWSP Water Supply Agreement with IID to process the untreated Colorado River water for the proposed project. The IWSP sets aside 25,000 AFY of IID's Colorado River water supply to serve new non-agricultural projects. As of April 2021, a

balance of 23,800 AFY remain available under the IWSP for new non-agricultural projects ensuring reasonably sufficient supplies for such projects. The proposed project has an estimated total water demand of 460 AF or 23 AFY amortized over a 20-year term (to be pumped to water trucks directly from the All-American Canal – there would be no diversion through any delivery gates for project). Thus, the proposed project demand is an increase of 23 AFY from the historical 10-year average. There has been no prior delivery for agricultural uses at the project site. The project's water demand of approximately 23 AFY amortized over 20 years represents 0.1 percent of the unallocated supply set aside in the IWSP for non-agricultural projects, and approximately 0.01 percent of forecasted future non-agricultural water demands planned in the Imperial IRWMP through 2055. Therefore, the amount of water available and the stability of the IID water supply along with on-farm and system efficiency conservation and other measures being undertaken by IID and its customers ensures that the project's needs will be met for the next 20 years as assessed for compliance under SB-610. Therefore, the proposed project would have sufficient water supplies available to serve the project from existing entitlements and resources, and impacts would be less than significant.

Mitigation Measure(s)

No mitigation measures are required.

3.15.4 Decommissioning/Restoration and Residual Impacts

Decommissioning/Restoration

If at the end of the PPA term, no contract extension is available for a power purchaser, no other buyer of the energy emerges, or there is no further funding of the project, the project will be decommissioned and dismantled. It is anticipated that a small quantity of water would be required during decommissioning of the project and site restoration. This water need would be less than what is required for construction and operation of the project site. Therefore, a less than significant impact is identified and no mitigation is required.

Residual

The proposed project would not result in significant impacts on the water supply of Imperial County; therefore, no mitigation is required. The proposed project will not result in residual impacts.

This page is intentionally blank.

4 Analysis of Long-Term Effects

4.1 Growth-Inducing Impacts

In accordance with Section 15126.2(d) of CEQA Guidelines, an EIR must:

“discuss the ways in which the proposed project could foster economic or population growth, or the construction of additional housing, either directly or indirectly, in the surrounding environment. Included in this are projects which would remove obstacles to population growth ... Increases in the population may tax existing community service facilities, requiring construction of new facilities that could cause significant environmental effects. Also discuss the characteristics of some projects which may encourage and facilitate other activities that could significantly affect the environment, either individually or cumulatively. It must not be assumed that growth in any area is necessarily beneficial, detrimental, or of little significance to the environment.”

Projects promoting direct growth will impose burdens on a community by directly inducing an increase in population or resulting in the construction of additional developments in the same area. For example, projects involving the expansion, modifications, or additions to infrastructure, such as sewer, water, and roads, could have the potential to directly promote growth by removing existing physical barriers or allowing for additional development through capacity increases. New roadways leading into a previously undeveloped area directly promote growth by removing previously existing physical barriers to development and a new wastewater treatment plant would allow for further development within a community by increasing infrastructure capacity. Because these types of infrastructure projects directly serve related projects and result in an overall impact to the local community, associated impacts cannot be considered isolated. Indirect growth typically includes substantial new permanent employment opportunities and can result from these aforementioned modifications.

The proposed project is located within the unincorporated area of Imperial County, and it does not involve the development of permanent residences that would directly result in population growth in the area. The unemployment rate in Imperial County, as of September 2022, was 16.0 percent (State of California Employment Development Department 2022). The applicant expects to utilize construction workers from the local and regional area, a workforce similar to that involved in the development of other utility-scale solar facilities. Based on the unemployment rate, and the availability of the local workforce, construction of the proposed project would not have a growth-inducing effect related to workers moving into the area and increasing the demand for housing and services.

Once construction is completed, the facility would be remotely operated, controlled and monitored and with no requirement for daily on-site employees. Security personnel may conduct unscheduled security rounds and would be dispatched to the project site in response to a fence breach or other alarm. It is anticipated that maintenance of the facilities would require minimal site presence to perform periodic visual inspections and minor repairs. On intermittent occasions, the presence of additional workers may be required for repairs or replacement of equipment and panel cleaning; however, because of the nature of the facility, such actions would likely occur infrequently. Overall, minimal maintenance requirements are anticipated. The proposed project would not result in substantial population growth, as the number of employees required to operate and maintain the facility is minimal.

While the proposed project would contribute to energy supply, which indirectly supports population growth, the proposed project is a response to the state’s need for renewable energy to meet its

Renewable Portfolio Standard, and while it would increase the availability of renewable energy, it would also replace existing sources of non-renewable energy. Unlike a gas-fired power plant, the proposed project is not being developed as a source of base-load power in response to growth in demand for electricity. The power generated would be added to the state's electricity grid with the intent that it would displace fossil fueled power plants and their associated environmental impacts, consistent with the findings and declarations in SB 100 that a benefit of the Renewable Portfolio Standard is displacing fossil fuel consumption within the state. The project is being proposed in response to state policy and legislation promoting development of renewable energy.

The proposed project would supply energy to accommodate and support existing demand and projected growth, but the energy provided by the project would not foster any new growth because (1) the additional energy would be used to ease the burdens of meeting existing statewide energy demands within and beyond the area of the project site; (2) the energy would be used to support already-projected growth; or, (3) the factors affecting growth are so diverse that any potential connection between additional energy production and growth would necessarily be too speculative and uncertain to merit further analysis.

Under CEQA, an EIR should consider potentially significant energy implications of a project (CEQA Guidelines Appendix F(II); PRC Section 21100(b)(3)). However, the relationship between the proposed project's increased electrical capacity and the growth-inducing impacts outside the surrounding area is too speculative and uncertain to warrant further analysis. When a project's growth-inducing impacts are speculative, the lead agency should consider 14 CCR §15145, which provides that, if an impact is too speculative for evaluation, the agency should note this conclusion and terminate discussion of the impact. As the court explained in *Napa Citizens for Honest Gov't v. Napa County Board of Supervisors*, 91 Cal. App.4th 342, 368: "Nothing in the Guidelines, or in the cases, requires more than a general analysis of projected growth" *Napa Citizens*, 91 CA4th at 369. The problem of uncertainty of the proposed project's growth-inducing effects cannot be resolved by collection of further data because of the diversity of factors affecting growth.

While this document has considered that the proposed project, as an energy project, might foster regional growth, the particular growth that could be attributed to the proposed project is unpredictable, given the multitude of variables at play, including uncertainty about the nature, extent, and location of growth and the effect of other contributors to growth besides the proposed project. No accurate and reliable data is available that could be used to predict the amount of growth outside the area that would result from the proposed project's contribution of additional electrical capacity. The County of Imperial has not adopted a threshold of significance for determining when an energy project is growth-inducing. Further evaluation of this impact is not required under CEQA.

Additionally, the project would not involve the development of any new roadways, new water systems, or sewer; and thus, the project would not further facilitate additional development into outlying areas. For these reasons, the proposed project would not be growth-inducing.

4.2 Significant Irreversible Environmental Changes

In accordance with CEQA Guidelines Section 15126.2(c), an EIR must identify any significant irreversible environmental changes that would be caused by implementation of the proposed project being analyzed. Irreversible environmental changes may include current or future commitments to the use of non-renewable resources or secondary growth-inducing impacts that commit future generations to similar uses.

Energy resources needed for the construction of the proposed project would contribute to the incremental depletion of renewable and non-renewable resources. Resources, such as timber, used in building construction are generally considered renewable and would ultimately be replenished. Non-renewable resources, such as petrochemical construction materials, steel, copper, lead and other metals, gravel, concrete, and other materials, are typically considered finite and would not be replenished over the lifetime of the project. Thus, the project would irretrievably commit resources over the anticipated 30-year life of the project.

At the end of the project's operation term, the applicant may determine that the project should be decommissioned and deconstructed. Should the project be decommissioned, the project applicant is required to restore land to its pre-project state. Consequently, some of the resources on the site could potentially be retrieved after the site has been decommissioned. Concrete footings, foundations, and pads would be removed and recycled at an off-site location. All remaining components would be removed, and all disturbed areas would be reclaimed and recontoured. The applicant anticipates using the best available recycling measures at the time of decommissioning.

Implementation and operation of the proposed project would promote the use of renewable energy and contribute incrementally to the reduction in demand for fossil fuel use for electricity-generating purposes. Therefore, the incremental reduction in fossil fuels would be a positive effect of the commitment of nonrenewable resources. Additionally, the project is consistent with the state's definition of an "eligible renewable energy resource" in Section 399.12 of the California Public Utilities Code and the definition of "in-state renewable electricity generation facility" in Section 25741 of the California PRC.

4.3 Unavoidable Adverse Impacts

In accordance with CEQA Guidelines Section 15126(b), EIRs must include a discussion of significant environmental effects that cannot be avoided if the proposed project is implemented. The impact analysis, as detailed in Section 3 of this EIR, concludes that no unavoidable significant impacts were identified. Where significant impacts have been identified, mitigation measures are proposed, that when implemented, would reduce the impact level to less than significant.

This page is intentionally blank.

5 Cumulative Impacts

The CEQA Guidelines (Section 15355) define a cumulative impact as “two or more individual effects which, when considered together, are considerable or which compound or increase other environmental impacts.” The CEQA Guidelines [Section 15130(a)(1)] further states that “an EIR should not discuss impacts which do not result in part from the project.”

Section 15130(a) of the CEQA Guidelines provides that “[A]n EIR shall discuss cumulative impacts of a project when the project’s incremental effect is cumulatively considerable...” Cumulatively considerable, as defined in Section 15065(a)(3), “means that the incremental effects of an individual project are significant when viewed in connection with the effects of past projects, the effects of other current projects, and the effects of probable future projects.”

An adequate discussion of significant cumulative impacts requires either: (1) “a list of past, present, and probable future projects producing related or cumulative impacts, including, if necessary, those projects outside the control of the agency; or (2) “a summary of projections contained in an adopted general plan or related planning document, or in a prior environmental document which has been adopted or certified, which described or evaluated regional or area-wide conditions contributing to the cumulative impact.”

The CEQA Guidelines recognize that cumulative impacts may require mitigation, such as new rules and regulations that go beyond project-by-project measures. An EIR may also determine that a project’s contribution to a significant cumulative impact will be rendered less than cumulatively considerable and thus is not significant. A project’s contribution is less than cumulatively considerable if the project is required to implement or fund its fair share of a mitigation measure or measures designed to alleviate the cumulative impact. The Lead Agency must identify facts and analysis supporting its conclusion that the contribution will be rendered less than cumulatively considerable (CEQA Guidelines Section 15130(a)(3)).

This EIR evaluates the cumulative impacts of the project for each resource area, using the following steps:

1. Define the geographic and temporal scope of cumulative impact analysis for each cumulative effects issue, based on the project’s reasonably foreseeable direct and indirect effects.
2. Evaluate the cumulative effects of the project in combination with past and present (existing) and reasonably foreseeable future projects and, in the larger context of the Imperial Valley.
3. Evaluate the project’s incremental contribution to the cumulative effects on each resource considered in Chapter 3, Environmental Analysis. When the project’s incremental contribution to a significant cumulative impact is considerable, mitigation measures to reduce the project’s “fair share” contribution to the cumulative effect are discussed, where required.

5.1 Geographic Scope and Timeframe of the Cumulative Effects Analysis

The geographic area of cumulative effects varies by each resource area considered in Chapter 3. For example, air quality impacts tend to disperse over a large area, while traffic impacts are typically more

localized. Similarly, impacts on the habitats of special-status wildlife species need to be considered within its range of movement and associated habitat needs.

The analysis of cumulative effects in this EIR considers a number of variables including geographic (spatial) limits, time (temporal) limits, and the characteristics of the resource being evaluated. The geographic scope of each analysis is based on the topography surrounding the project site and the natural boundaries of the resource affected, rather than jurisdictional boundaries. The geographic scope of cumulative effects will often extend beyond the scope of the direct effects of a project, but not beyond the scope of the direct and indirect effects of that project.

The cumulative development scenario includes projects that extend through year (2030), which is the planning horizon of the County of Imperial General Plan. Because of uncertain development patterns that are far in the future, it is too speculative to accurately determine the type and quantity of cumulative projects beyond the planning horizon of the County's adopted County General Plan. Evaluating the proposed project's cumulative impacts when future facility decommissioning occurs is highly speculative because decommissioning is expected to occur in 20 to 25 years' time. Therefore, cumulative impacts during decommissioning are speculative for detailed consideration in this analysis.

5.2 Projects Contributing to Potential Cumulative Impacts

The CEQA Guidelines identify two basic methods for establishing the cumulative environment in which the projects are to be considered: the use of a list of past, present, and probable future projects (the "list approach") or the use of adopted projections from a general plan, other regional planning document, or certified EIR for such a planning document (the "plan approach").

For this EIR, the list approach has been utilized to generate the most reliable future projections of possible cumulative impacts. When the impacts of the project are considered in combination with other past, present, and future projects to identify cumulative impacts, the other projects considered may also vary depending on the type of environmental impacts being assessed. As described above, the general geographic area associated with different environmental impacts of the project defines the boundaries of the area used for compiling the list of projects considered in the cumulative impact analysis. Figure 5-1 provides the general location for each of these projects in relation to the project site.

5.3 Cumulative Impact Analysis

This cumulative impact analysis utilizes an expanded list method (as defined under CEQA) and considers environmental effects associated with those projects identified in Table 5-1 in conjunction with the impacts identified for the project in Chapter 3 of this EIR. Table 5-1 includes projects known at the time of release of the NOP of the Draft EIR, as well as additional projects that have been proposed since the NOP date. Figure 5-1 provides the general location for each of these projects in relation to the project site.



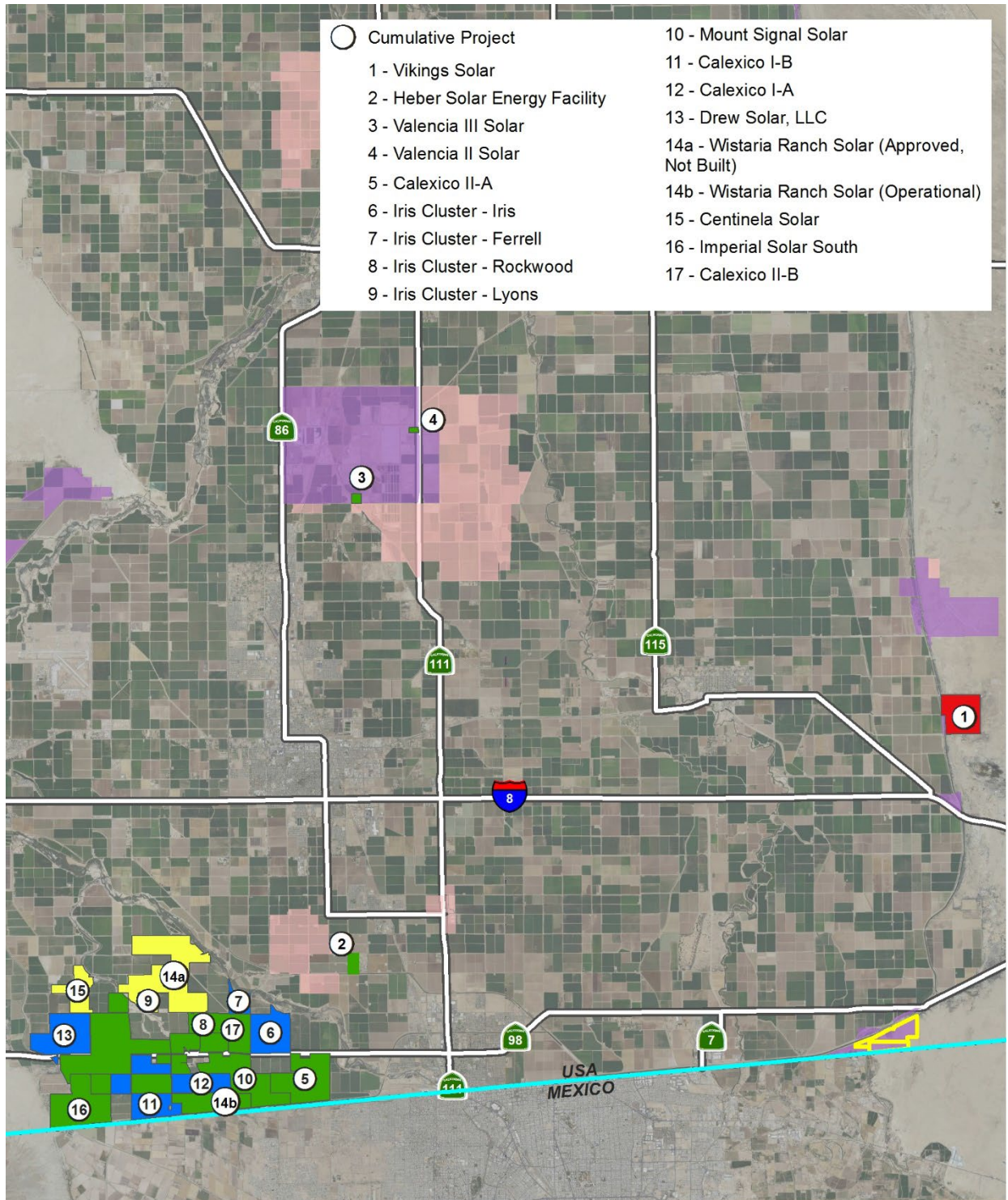
Table 5-1. Projects Considered in the Cumulative Impact Analysis

Map Label ¹	Project Name	Project Type	Distance from Project Site (miles)	Capacity (MW)	Status ²
1	Vikings Solar	PV Solar Facility	3.0	150	Pending Entitlement
2	Heber Solar Energy Facility	PV Solar Facility	5.1	14	Operational
3	Valencia III Solar	PV Solar Facility	7.1	3	Operational
4	Valencia II Solar	PV Solar Facility	7.2	3	Operational
5	Calexico II-A	PV Solar Facility	5.5	200	Operational
6	Iris Cluster – Iris Solar Facility	PV Solar Facility	5.8	130	Approved – Under Construction
7	Iris Cluster – Ferrell Solar Facility	PV Solar Facility	6.1	90	Approved – Under Construction
8	Iris Cluster - Rockwood	PV Solar Facility	6.4	100	Operational
9	Iris Cluster - Lyons	PV Solar Facility	6.9	40	Approved – Not Built
10	Mount Signal Solar	PV Solar Facility	6.4	800	Operational
11	Calexico I-B	PV Solar Facility	7.0	100	Approved – Under Construction
12	Calexico I-A	PV Solar Facility	6.6	100	Approved – Under Construction
13	Drew Solar	PV Solar Facility	7.7	100	Approved – Under Construction
14a	Wistaria Ranch Solar (Approved, Not Built)	PV Solar Facility	6.6	250	Approved – Not Built
14b	Wistaria Ranch Solar (Operational)	PV Solar Facility	6.8	250	Operational
15	Centinela Solar	PV Solar Facility	7.6	275	Approved – Not Built
16	Imperial Solar South	PV Solar Facility	7.6	130	Operational
17	Calexico II-B	PV Solar Facility	6.1	200	Operational

1 – See Figure 5-1 for cumulative project location.

2 – Project status based on information provided by County staff and on Imperial County Planning & Development Service’s RE Geographic Information System Mapping Application (<https://icpds.maps.arcgis.com/apps/webappviewer/index.html?id=0d869c18d11645cc918391fdcac24b80>). Accessed in November 2022.

Figure 5-1. Cumulative Projects



Legend

VEGA SES 4 Project Parcels

Renewable Energy Overlay

- Geothermal Only
- Renewable Energy/Geothermal

Solar Projects

- Approved - Not Built
- Approved - Under Construction
- Operational
- Pending Entitlement



5.3.1 Aesthetics and Visual Resources

The cumulative study area for projects considered in the visual resources cumulative impact analysis considers a 5-mile radius from the project site. Views beyond 5 miles are obstructed by a combination of the flat topography coupled with the Earth's curvature. The short-term visual impacts of the project would be in the form of general construction activities including grading, use of construction machinery, and installation of the transmission poles and stringing of transmission lines, but would only be available to a very limited amount of people and would have to be in relative close proximity to the project site. Longer-term visual impacts of the project would be in the form of the presence of solar array grids, battery storage containers, an electrical distribution and transmission system, and substation.

As discussed in Section 3.2, Aesthetics and Visual Resources, visibility of the project site from the public right of way is obstructed from SR-98 by a berm. Surrounding property is privately owned and viewers would be limited to private property owners, employees servicing/maintaining IID facilities (e.g., the All-American Canal), and U.S. Border Patrol personnel.

The visual changes associated with the project would be located in a remote area viewed by a minimal number of people, the project site is not located within scenic vistas, and is not readily viewable from any frequently travelled interstates or scenic highways. Further, the project site would be restored to its existing condition following the decommissioning of the solar uses. As a result, although the visual character of the project site would change from undeveloped to one with developed characteristics, a less than significant impact associated with the proposed project has been identified.

Development of the proposed project in conjunction with the cumulative projects identified in Table 5-1 will gradually change the visual character of this portion of the Imperial Valley. However, projects located within private lands and/or under the jurisdiction of the County of Imperial are being designed in accordance with the County of Imperial's General Plan and Land Use Ordinance, which includes policies to protect visual resources in the County.

Finally, all projects listed in Table 5-1 would not produce a substantial amount of light and glare, as no significant source of light or glare is proposed, or the project will otherwise comply with the County lighting ordinance, as would all other related projects. Based on these considerations, there would be no significant cumulatively considerable aesthetic impact, and cumulative aesthetic impacts would be less than significant.

5.3.2 Agricultural Resources

Cumulative impacts on agricultural resources take into account the proposed project's temporary impacts as well as those likely to occur as a result of other existing, proposed, and reasonably foreseeable projects. To determine cumulative impacts on agricultural resources, an assessment is made of the temporal nature of the impacts on individual resources (e.g., temporary such as in solar projects versus permanent as in industrial or residential developments) as well as the inventory of agricultural resources within the cumulative setting.

As discussed in Section 3.3, Agricultural Resources, the project does not contain Prime Farmland, Farmland of Statewide Importance, or Unique Farmland. Therefore, the proposed project would not convert land designated as Prime Farmland, Farmland of Statewide Importance, or Unique Farmland to non-agricultural uses or incrementally add to the conversion of agricultural land in Imperial County on a temporary or permanent basis. Furthermore, the project site is located within the Renewable

Energy Zone and is, therefore, considered an appropriate use in this area. Additionally, as a condition of project approval (CUP condition), the project applicant or its successor in interest will be responsible for implementing a reclamation plan when the project is decommissioned at the end of its lifespan.

A portion of the project site is designated as Farmland of Local Importance. It should be noted that analysis of Other Land and Farmland of Local Importance is not required under CEQA significance criteria, as these designations are not considered an “agricultural land” per CEQA Statute Section 21060.1(a). However, in terms of preservation of agricultural land Mitigation Measure AG-1 would be implemented to reduce potential impacts related to pests to a less than significant level. Each individual cumulative project would be or would have been required to provide mitigation for any impacts on agricultural resources in accordance with the County’s policies directed at mitigating the impact associated with the conversion of important farmlands. Therefore, the project’s contribution to this impact would be less than cumulatively considerable.

5.3.3 Air Quality

Imperial County is used as the geographic scope for analysis of cumulative air quality impacts. As shown in Table 5-1, many of the cumulative projects are large-scale renewable energy generation projects, where the main source of air emissions would be generated during the construction phases of these projects; however, there would also be limited operational emissions associated with operations and maintenance activities for these facilities. Additionally, several of the projects listed in Table 5-1 are already constructed and in operation. Furthermore, the remaining cumulative projects are currently under construction, or approved and not built (Iris Cluster – Lyons and Centinela Solar), and not anticipated to involve overlapping construction activities with the proposed project. Therefore, the potential for a cumulative, short-term air quality impact as a result of construction activities is anticipated to be less than significant.

Currently, the SSAB is either in attainment or unclassified for all federal and state air pollutant standards with the exception of 8-Hour O₃ and PM_{2.5}. On November 13, 2009, EPA published Air Quality Designations for the 2006 24-Hour Fine Particle (PM_{2.5}) NAAQS wherein Imperial County was listed as designated nonattainment for the 2006 24-hour PM_{2.5} NAAQS. However, the nonattainment designation for Imperial County is only for the urban area within the County and it has been determined that the proposed project is not located within the nonattainment boundaries for PM_{2.5}.

The AQAP for the SSAB, through the implementation of the AQMP and SIP for PM₁₀, sets forth a comprehensive program that will lead the SSAB into compliance with all federal and state air quality standards. With respect to PM₁₀, the ICAPCD implements Regulation VIII – Fugitive Dust Rules, to control these emissions and ultimately lead the basin into compliance with air standards, consistent with the AQAP. Within Regulation VIII are Rules 800 through 806, which address construction and earthmoving activities, bulk materials, carry-out and track-out, open areas, paved and unpaved roads, and conservation management practices. Best Available Control Measures to reduce fugitive dust during construction and earthmoving activities include but are not limited to:

- Phasing of work in order to minimize disturbed surface area;
- Application of water or chemical stabilizers to disturbed soils;
- Construction and maintenance of wind barriers; and
- Use of a track-out control device or wash down system at access points to paved roads.

Compliance with Regulation VIII is mandatory on all construction sites, regardless of size. However, compliance with Regulation VIII does not constitute mitigation under the reductions attributed to environmental impacts. In addition, compliance for a project includes: (1) the development of a dust control plan for the construction and operational phase; and (2) notification to the air district is required 10 days prior to the commencement of any construction activity.

Construction

The proposed project would generate air emissions due to vehicle and dust emissions associated with construction activities. Similar effects would also be realized upon site decommissioning, which would be carried out in conjunction with the project's restoration plan, and subject to applicable ICAPCD standards. Likewise, the other cumulative projects (Table 5-1), would result in the generation of air emissions during construction activities.

With respect to the proposed project, during the construction and decommissioning phases, the project would generate ROG, NO_x, CO, SO₂, PM₁₀, and PM_{2.5} emissions during each active day of construction. As discussed in Section 3.4, Air Quality, the project's daily construction emissions would not exceed the ICAPCD thresholds for ROG, NO_x, CO, SO₂, and PM_{2.5}. However, the project would exceed the ICAPCD threshold for PM₁₀ and represents a significant air quality impact. The project's impact could be cumulatively considerable because the Imperial County portion of the SSAB are nonattainment already for O₃ and PM₁₀ under state standards and for O₃ and PM_{2.5} federal standards. Thus, existing O₃ and PM₁₀ levels in the SSAB are at unhealthy levels during certain periods. Additionally, the cumulative construction effects could again be experienced in the future during decommissioning and site restoration activities.

Several of the projects listed in Table 5-1 are already constructed and in operation. Furthermore, the remaining cumulative projects, with exception of the Vikings Solar, Iris Cluster – Lyons, and Centinela Solar Projects, are currently under construction and not anticipated to involve overlapping construction activities with the proposed project. In the event the proposed project is constructed in conjunction with the Vikings Solar Project (pending entitlement), Iris Cluster – Lyons (approved but not built), and Centinela Solar Project (approved but not built), each project would be subject to mitigation pursuant to ICAPCD's Regulations. Therefore, the cumulative impact would be reduced to a level less than significant through compliance with these measures. Further, because the proposed project will be required to implement measures consistent with ICAPCD regulations designed to alleviate the cumulative impact associated with fugitive dust (PM₁₀) and NO_x, the project's contribution would be rendered less than cumulatively considerable and is therefore, less than significant.

Operation

As the proposed project would have no major stationary emission sources and would require minimal vehicular trips, operation of the proposed solar facility would result in substantially lower emissions than project construction. The project's operational emissions would not exceed the Tier I thresholds; therefore, the impact would be less than significant. Operational impacts of other renewable energy facilities identified in Table 5-1 would also be similar. Although these cumulative projects generally involve large areas, their operational requirements are very minimal, requiring minimal staff or use of machinery or equipment that generate emissions. Further, alternative energy projects, such as the project, would assist attainment of regional air quality standards and improvement of regional air quality by providing clean, renewable energy sources. Consequently, the projects would provide a

positive contribution to the implementation of applicable air quality plan policies and compliance with EO S-3-05.

However, from a cumulative air quality standpoint, the potential cumulative impact associated with the generation of O₃, PM_{2.5} and PM₁₀ emissions during operation of the cumulative projects is a consideration because existing O₃ and PM₁₀ levels in the SSAB are at unhealthy levels during certain periods. Imperial County is classified as non-attainment for PM_{2.5} for the urban areas of Imperial County. However, the project's operational contribution to O₃, PM_{2.5} and PM₁₀ would be below a level of significance. As with the construction phases, the cumulative projects would be required to comply with ICAPCD's Regulation VIII for dust control (Regulation VIII applies to both the construction and operational phases of projects). As a result, the ICAPCD would be required to comply with the various dust control measures and to prepare and implement operational dust control plans as approved by the ICAPCD, which is a component of ICAPCD's overall framework of the AQAP that sets forth a comprehensive program for SSAB's compliance with all federal and state air quality standards. Therefore, the project would not contribute to long-term cumulatively considerable air quality impacts and the project would not result in cumulatively significant air quality impacts, and cumulative impacts would be less than significant.

5.3.4 Biological Resources

The geographic scope for considering cumulative impacts on biological resources includes the Imperial Valley and related biological habitats. Table 5-1 lists the projects considered for the biological resources cumulative impact analysis.

In general terms, in instances where a potential impact could occur, CDFW and USFWS have promulgated a regulatory scheme that limits impacts on these species. The effects of the project would be rendered less than significant through implementation of Mitigation Measures BIO-1 to BIO-7 (Section 3.5, Biological Resources) which require compliance with all applicable regulations that protect plant, fish, and animal species. Other cumulative projects would also be required to avoid impacts on special-status species and/or mitigate to the satisfaction of the CDFW and USFWS for the potential loss of habitat. As described in Section 3.5, Biological Resources, the project has the potential to result in impacts on biological resources. These impacts are generally focused on potential construction-related effects to special-status plant species and wildlife.

The proposed project has been designed to avoid impacts to the riparian habitat, disturbed riparian habitat, and tamarisk thickets (CDFW sensitive natural community) within the project site. However, 14 special-status plant species that have the potential to occur within the project site. 11 of these plant species have a low potential to occur due to limited suitable habitat. Due to the presence of suitable habitat and several known recent occurrences within five miles of the project site, the following species were determined to have moderate potential to occur: Abram's spurge (CRPR 2B.2), Wiggins' croton (CRPR 2B.2), and sand food (CRPR 1B.2). Implementation of Mitigation Measures BIO-1, BIO-2, and BIO-3 would reduce project impacts to a level less than significant.

Burrowing Owls are protected by the CDFW mitigation guidelines for burrowing owl (CDFW 2012) and Consortium guidance (1993), which require a suite of mitigation measures to ensure direct effects to burrowing owls during construction activities are avoided and indirect effects through burrow destruction and loss of foraging habitat are mitigated at prescribed ratios. Additionally, as provided in Section 3.5, Biological Resources, special-status bird species have a potential to be present. In addition, several common bird species could nest on the project site. As a result of project-related construction activities, one or more of these protected species could be harmed. However, with the

implementation of Mitigation Measures BIO-2 through BIO-7, as identified in Section 3.5, Biological Resources, these impacts would be reduced to a level of less than significant.

As with the proposed project, the cumulative projects within the geographic scope of the project would be required to comply with the legal framework and provide mitigation for impacts on biological resources as described above. Based on these considerations, impacts on biological resources would not be cumulatively considerable.

The analysis below is conducted qualitatively and in the context that the cumulative projects would be subject to a variety of statutes and administrative frameworks that require mitigation for impacts on biological resources.

Birds listed at 50 CFR 10.3 are protected by the MBTA (16 USC 703 et seq.), a Federal statute that implements treaties with several countries on the conservation and protection of Birds listed at 50 CFR 10.3 are protected by the MBTA (16 USC 703 et seq.), a Federal statute that implements treaties with several countries on the conservation and protection of migratory birds. The MBTA is enforced by USFWS. This act prohibits the killing of any migratory birds without a valid permit. Any activity which contributes to unnatural migratory bird mortality could be prosecuted under this act. With few exceptions, most birds are considered migratory under this act. Raptors and active raptor nests are protected under California FGCs 3503.5, 3503, and 3513.

The CWA and California's Porter-Cologne Water Quality Control Act provide protection for water-related biological resources by controlling pollution, setting water quality standards, and preventing jurisdictional streams, lakes, and rivers from being filled without a federal permit. Freshwater forested/shrub wetland are present within the project site. Additionally, perennial and ephemeral drainage features are also present and convey flows in the wetlands within and around the All-American Canal. As such, these drainage features would likely be considered federally and state jurisdictional. However, the proposed project has been designed to avoid impacts to aquatic resources. As shown on the Site Plan (Figure 2-3), project components would not be sited on the project site where aquatic resources are present. Therefore, implementation of the project would result in no impact on state or federally protected aquatic resources.

The proposed project would comply with these and other laws, regulations and guidelines and therefore would not contribute substantially to a cumulative biological resources impact. Similarly, the cumulative projects within the geographic scope of the proposed project will be required to comply with the legal frameworks set forth above, as well as others, and will be required to mitigate their impacts to a less than significant level. Therefore, the project would not contribute to a cumulatively considerable impact to biological resources, and cumulative impacts would be less than significant.

5.3.5 Cultural Resources

As discussed in Section 3.6, Cultural Resources, five cultural resources are being treated as eligible for listing in the CRHR as historical resources. However, the project has been designed to avoid all five historical resources and Mitigation Measure CR-1 will be implemented to ensure the sites are avoided during construction. Mitigation Measure CR-1 requires the installation of orange environmentally sensitive area fencing or flagging around the boundaries of each of the resources prior to any construction activity and shall remain in place throughout project construction. Further, in the event that unknown cultural resources are discovered during project construction, significant impacts could occur. Therefore, Mitigation Measure CR-2 would be implemented to reduce potential impacts to previously unrecorded cultural resources to a level less than significant.

The potential of finding a buried archaeological site during construction is considered low. However, like all construction projects in the state, the possibility exists. This potential impact is considered significant. Implementation of Mitigation Measure CR-3 would reduce potential impacts associated with the unanticipated discovery of unknown buried archaeological resources. Additionally, implementation of Mitigation Measure CR-4 would reduce potential impacts on human remains to a level less than significant.

Future projects with potentially significant impacts on cultural resources would be required to comply with federal, state, and local regulations and ordinances protecting cultural resources through implementation of similar project-specific mitigation measures during construction. Therefore, through compliance with regulatory requirements, standard conditions of approval, and Mitigation Measures CR-1 through CR-4, the proposed project would have a less than cumulatively considerable contribution to impacts on cultural resources.

During operations and decommissioning of the project, no additional impacts on archeological resources would be anticipated because the soil disturbance would have already occurred and been mitigated during construction.

5.3.6 Geology and Soils

The Imperial Valley portion of the Salton Trough physiographic province of Southern California is used as the geographic scope for the analysis of cumulative impacts on geology/soils and mineral resources. Cumulative development would result in an increase in population and development that could be exposed to hazardous geological conditions, depending on the location of proposed developments. Geologic and soil conditions are typically site specific and can be addressed through appropriate engineering practices. Cumulative impacts on geologic resources would be considered significant if the project would be impacted by geologic hazard(s) and if the impact could combine with off-site geologic hazards to be cumulatively considerable. None of the projects identified within the geographic scope of potential cumulative impacts would intersect or be compounded with the project's site-specific geology and soils impacts which would be addressed by a site-specific geotechnical report per Mitigation Measure GEO-1. Therefore, no cumulatively considerable effects are identified for geology/soils, and cumulative impacts would be less than significant.

Development of the proposed project, in combination with other projects in the area, has the potential to contribute to a cumulatively significant paleontological resources impact due to the potential loss of paleontological resources unique to the region. However, mitigation is included in this EIR to reduce potentially significant project impacts to paleontological resources during construction of the proposed project. Implementation of Mitigation Measure GEO-2 would ensure that the potential impacts on paleontological resources do not rise to the level of significance. Future projects with potentially significant impacts on paleontological resources would be required to comply with federal, state, and local regulations and ordinances protecting paleontological resources through implementation of similar project-specific mitigation measures during construction. Therefore, through compliance with regulatory requirements, standard conditions of approval, and Mitigation Measure GEO-2, the proposed project would have a less than cumulatively considerable contribution to impacts on paleontological resources.

5.3.7 Greenhouse Gas Emissions

Emissions of GHGs have the potential to adversely affect the environment because such emissions contribute, on a cumulative basis, to global climate change. Although the emissions of the projects

alone would not cause global climate change, GHG emissions from multiple projects throughout the world could result in a cumulative impact with respect to global climate change. In turn, global climate change has the potential to result in rising sea levels, which can inundate low-lying areas; affect rainfall and snowfall, leading to changes in water supply; and affect habitat, leading to adverse effects on biological resources. The ICAPCD has not adopted a GHG significance threshold. Thus, in the absence of any GHG emissions significance thresholds, the projected emissions of the project are compared to the Mojave Desert Air Quality Management District (MDAQMD) numeric threshold of 100,000 metric tons of CO₂e annually. While significance thresholds used in the Mojave Desert Air Basin are not binding on the ICAPCD or County of Imperial, they are instructive as a comparative metric of the project's potential GHG impact. This threshold is also appropriate as the MDAQMD GHG thresholds were formulated based on similar geography and climate patterns as found in Imperial County. Therefore, the 100,000-metric ton of CO₂e threshold is appropriate for this analysis.

As discussed in Section 3.8, Greenhouse Gas Emissions, the proposed project's CO₂ emissions would not exceed MDAQMD's threshold of 100,000 MTCO₂e per year. As the project's emissions do not exceed the MDAQMD's significance threshold, the proposed project would not result in a cumulatively considerable impact to GHG emissions and would not conflict with the State GHG reduction targets. Other cumulative projects identified in Table 5-1 consist of utility-scale solar facilities. Like the project, the nature of these projects would be consistent with the strategies of the Climate Change Scoping Plan. In order to meet the AB 32 GHG emissions reduction mandate, the Scoping Plan relies on achievement of the RPS target of 33 percent of California's energy coming from renewable sources by 2020 and 50 percent by 2030. The RPS target was updated in September 2018 under SB 100 to 60 percent by 2030 and 100 percent by 2045. The project and other similar projects are essential to achieving the RPS.

Given that the project is characterized as a renewable energy project and places emphasis on solar power generation, project operations would be almost carbon-neutral with the majority of the operational GHG emissions associated with vehicle trips. Based on these considerations, no significant long-term operational GHG impacts would occur; therefore, project-related GHG impacts would not be cumulatively considerable.

5.3.8 Hazards/Hazardous Materials

The geographic scope considered for cumulative impacts from health, safety, and hazardous materials is the area within 1 mile of the boundary of the project site. One mile is the standard American Society of Testing and Materials (ASTM) standard search distance for hazardous materials.

Under cumulative conditions, implementation of the project in conjunction with the projects listed in Table 5-1 is not anticipated to present a public health and safety hazard to residents. Additionally, the project and related projects would all involve the storage, use, disposal, and transport of hazardous materials to varying degrees during construction, operation, and decommissioning. Impacts from these activities are less than significant for the project because the storage, use, disposal, and transport of hazardous materials are extensively regulated by various Federal, state, and local laws, regulations, and policies. It is foreseeable that the project and related projects would implement and comply with these existing hazardous materials laws, regulations, and policies. Therefore, the related projects would not cause a cumulative impact, and the project would not result in a cumulatively considerable incremental contribution to a cumulative impact related to use or routine transport of hazardous materials.

5.3.9 Hydrology and Water Quality

Table 5-1 lists the projects considered for the hydrology and water quality cumulative impact analysis. The geographic scope for considering cumulative hydrology and water quality impacts is the Imperial Valley Hydrologic Unit as defined by the Colorado Basin RWQCB Basin Plan.

The construction of the project is expected to result in short-term water quality impacts. Compliance with the SWRCB's NPDES general permit for activities associated with construction (2009-0009-DWQ) per Mitigation Measure HYD-1 would reduce water quality impacts. As with the project, future cumulative projects would be required to comply with the Construction General Permit. The SWRCB has determined that the Construction General Permit protects water quality, is consistent with the CWA, and addresses the cumulative impacts of numerous construction activities throughout the state. This determination in conjunction with the implementation of mitigation would ensure short-term water quality impacts are not cumulatively considerable.

The project is not expected to result in long-term operations-related impacts related to water quality. The project would mitigate potential water quality impacts by preparing a drainage plan that would implement site design, source control, and treatment control BMPs per Mitigation Measure HYD-2. Future cumulative projects may also be required to comply with the SWRCB's NPDES general permit for industrial activities, as well as rules found in the CWA, Section 402(p)(1) and 40 CFR 122.26, and implemented Order No. 90-42 of the RWQCB. With implementation of SWRCB, Colorado River RWQCB, and County policies, plans, and ordinances governing land use activities that may degrade or contribute to the violation of water quality standards, cumulatively considerable impacts on water quality would be minimized to a less than significant level.

Based on a review of the FEMA Flood Insurance Rate Map FIRM, the proposed solar energy facility, gen-tie line, and access roads located on the western portion of the project site are located in Zone X (unshaded). The FEMA Zone X (unshaded) designation is an area determined to be outside the 0.2 percent annual chance floodplain. As such, the project would not result in a significant cumulatively considerable impact on floodplains by constructing new facilities within an identified flood hazard zone.

Based on these considerations, the project would not contribute to or result in a significant cumulatively considerable impact to hydrology or water quality, and cumulative impacts would be less than significant.

5.3.10 Land Use Planning

The geographic scope for the analysis of cumulative land use and planning impacts is typically defined by government jurisdiction. The geographic scope for considering potential inconsistencies with the General Plan's policies from a cumulative perspective includes all lands within the County's jurisdiction and governed by its currently adopted General Plan. In contrast, the geographic scope for considering potential land use impacts or incompatibilities include the project site plus a one-mile buffer to ensure a consideration for reasonably anticipated potential direct and indirect cumulative impacts.

As provided in Section 3.11, Land Use/Planning, the project would not involve any facilities that could otherwise divide an established community. Based on this circumstance, no cumulatively considerable impacts would occur. As discussed in Section 3.11, Land Use/Planning, the project would not conflict with the goals and objectives of the County of Imperial General Plan. With approval of a CUP for the project, the proposed project would not conflict with the County's zoning ordinance. In addition, the cumulative projects identified in Table 5-1 would not result in a conflict with applicable land use plans, policies, or regulations. In the event that incompatibilities or land use conflicts are identified for other

projects listed in Table 5-1, similar to the project, the County would require mitigation to avoid or minimize potential land use impacts. Where General Plan Amendments and/or Zone Changes are required to extend the RE Overlay Zone, that project would be required to demonstrate consistency with the overall goals and policies of the General Plan, and would be required to demonstrate meeting the criteria for extending the RE Overlay onto the project site. Based on these circumstances, no significant cumulatively considerable impact would occur, and cumulative impacts would be less than significant.

5.3.11 Noise and Vibration

When determining whether the overall noise (and vibration) impacts from related projects would be cumulatively significant and whether the project's incremental contribution to any significant cumulative impacts would be cumulatively considerable, it is important to note that noise and vibration are localized occurrences; as such, they decrease rapidly in magnitude as the distance from the source to the receptor increases. Therefore, only those related projects and identified in Table 5-1 that are in the vicinity of the project site and those that are considered influential in regard to noise and vibration would have the potential to be considered in a cumulative context with the project's incremental contribution.

Several of the projects listed in Table 5-1 are already constructed and in operation. Furthermore, the remaining cumulative projects, with exception of the Vikings Solar, Iris Cluster – Lyons, and Centinela Solar Projects, are currently under construction and not anticipated to involve overlapping construction activities with the proposed project. As discussed in Section 3.12, Noise and Vibration, the project's noise levels would not exceed the County's 75 dBA L_{eq} construction noise threshold. Therefore, impacts from construction noise are considered less than significant. Similar to the proposed project, other cumulative projects would be required to comply with the County's construction noise standards. Construction activity is limited to the hours of 7 a.m. to 7 p.m. Monday through Friday, and 9 a.m. to 5 p.m. on Saturdays. Adhering to the County's construction hours would reduce the noise and vibration impacts to below a level of significance. Thus, the incremental contribution of the project to a cumulative noise impact would not be cumulatively considerable.

Stationary-source and vehicular noise from the aforementioned related projects would be similar in nature and magnitude to those discussed for the projects in Section 3.12, Noise and Vibration. For the proposed project, no noise impacts have been identified. Operation of the other cumulative projects listed in Table 5-1 could result in the long-term stationary source noise levels that exceed applicable standards at nearby sensitive receptors and/or result in substantial increases in ambient noise levels. However, given that the project facilities would be located at appropriate distances from the residential uses scattered in this portion of the County, long-term operational noise levels are not expected to exceed normally acceptable noise levels for these zones (e.g., 70 dBA L_{dn}). Thus, the incremental contribution of the project to significant cumulative noise impacts would not be cumulatively considerable.

5.3.12 Transportation

During the construction phase of the project, the maximum number of trips generated on a daily basis would be approximately 520 trips. Under construction year conditions with and without the proposed project, all roadway segments analyzed would operate at LOS A or better, all intersections would operate at a LOS B or better during both AM and PM peak hours, and all freeway segments would operate at LOS B or better during both AM and PM peak hours. Implementation of the proposed project

would not require any public road widening to accommodate vehicular trips associated with the proposed project (construction phase and operational phase), while maintaining adequate LOS. Additionally, future operations and maintenance would be conducted remotely, with minimal trips to the project site for panel washing and other solar maintenance.

Since the proposed project is located in a rural portion of the County there are no fixed routes for alternative transportation or non-motorized travel within the general area of the project site that would be impacted by project construction or operation. Although the proposed project would increase VMT during the construction phase, these increases are temporary in nature. Operation of proposed projects would only require intermittent maintenance which would result in a nominal amount of vehicle trips generated.

A majority of the projects listed in Table 5-1 are already constructed. Furthermore, the remaining cumulative projects, with exception of the Vikings Solar, Iris Cluster – Lyons, and Centinela Solar Projects, are currently under construction and not anticipated to involve overlapping construction activities with the proposed project. The other cumulative projects would also likely result in a nominal amount of vehicle trips for maintenance and operation as a solar facility. Based on these findings, the proposed project would not result in cumulatively considerable roadway or intersection impacts, and this impact would be less than significant.

5.3.13 Tribal Cultural Resources

As discussed in Section 3.14, Tribal Cultural Resources, a SLF search request was submitted on September 15, 2020 to the California NAHC and the search results were received on September 29, 2020. The search of the SLF was negative and failed to indicate the presence of Native American cultural resources in the project area. Additionally, on April 1, 2021, the Quechan Indian Tribe requested consultation with the County on the proposed project. The County is in the process of consulting with the Quechan Indian Tribe and has requested that they to provide any information regarding any Traditional Cultural Properties, Sacred Sites, resource collecting areas, or any other areas of concern known to occur in the project area. However, the proposed project is not anticipated to cause a substantial adverse change in the significance of a tribal cultural resource, defined in PRC section 21074 or a resource determined by the lead agency, in its discretion and supported by substantial evidence, to be significant pursuant to criteria set forth in subdivision (c) of PRC Section 5024.1 and Section 5024.1.

Future cumulative projects would also be required to comply with the requirements of AB 52 to determine the presence/absence of tribal cultural resources and engage in consultation to determine appropriate mitigation measures to minimize or avoid impacts on tribal cultural resources. Based on these considerations, the project would not contribute to or result in a significant cumulatively considerable impact tribal cultural resources. During operations and decommissioning of the project, no impacts on tribal cultural resources are anticipated because the soil disturbance would have already occurred and been mitigated during construction.

5.3.14 Utilities/Service Systems

Future development in Imperial County would increase the demand for utility service in the region. In terms of cumulative impacts, the appropriate service providers are responsible for ensuring adequate provision of public utilities within their jurisdictional boundaries. The project would not require or result in the relocation or construction of new or expanded wastewater facilities, storm water facilities, or



water facilities. Additionally, the project would be comprised of mostly recyclable materials and would not generate significant volumes of solid waste that could otherwise contribute to significant decreases in landfill capacity. Based on these considerations, the project would result in less than significant impacts on existing utility providers and, therefore, would not result in cumulatively considerable impacts.

This page is intentionally blank.

6 Effects Found Not Significant

In accordance with Section 15128 of the CEQA Guidelines, an EIR must contain a statement briefly indicating the reasons that various potential significant effects of a project were determined not to be significant. Based on the Initial Study and Notice of Preparation prepared for the proposed project (Appendix A of this EIR), Imperial County has determined that the proposed project would not have the potential to cause significant adverse effects associated with the topics identified below. Therefore, these topics are not addressed in this EIR; however, the rationale for eliminating these topics is briefly discussed below.

6.1 Agriculture and Forestry Resources

6.1.1 Forestry Resources

No portion of the project site or the immediate vicinity is zoned or designated as forest lands, timberlands, or timberland production. As such, the proposed project would not result in a conflict with existing zoning or cause the need for a zone change. Therefore, implementation of the proposed project would not impact forestry resources.

6.2 Energy

Information for this section is summarized from the Energy Impact Assessment prepared by ECORP Consulting, Inc. This report is included in Appendix M of this EIR.

6.2.1 Energy Types and Sources

California relies on a regional power system comprised of a diverse mix of natural gas, renewable, hydroelectric, and nuclear generation resources. Natural gas provides California with a majority of its electricity followed by renewables, large hydroelectric and nuclear. IID, the sixth largest electrical utility in California serving more than 150,000 customers in the Imperial Valley and parts of Riverside and San Diego counties, provides electrical services to the project area. IID controls more than 1,100 megawatts of energy derived from a diverse resource portfolio that includes its own generation, and long- and short-term power purchases. Located in a region with abundant sunshine, enviable geothermal capacity, wind and other renewable potential, IID has met or exceeded all Renewable Portfolio Standard requirements to date, procuring renewable energy from diverse sources, including biomass, biowaste, geothermal, hydroelectric, solar and wind (Appendix M of this EIR).

The Southern California Gas Company provides natural gas services to Imperial County. As the nation's largest natural gas distribution utility, the Southern California Gas Company delivers natural gas energy to 21.6 million consumers through 5.9 million meters in more than 500 communities. The Southern California Gas Company's service territory encompasses approximately 20,000 square miles throughout Central and Southern California, from Visalia to the Mexican border (Appendix M of this EIR).

6.2.2 Imperial County Energy Consumption

Electricity

The electricity consumption associated with all uses in Imperial County from 2015 to 2019 is shown in Table 6-1. As shown, the demand has remained constant since 2015.

Table 6-1. Electricity Consumption in Imperial County 2015–2019

Year	Electricity Consumption (kilowatt hours)
2019	1,415,790,908
2018	1,467,590,638
2017	1,445,167,336
2016	1,440,493,016
2015	1,419,088,130

Source: Appendix M of this EIR

Natural Gas

The natural gas consumption associated with all uses in Imperial County from 2015 to 2019 is shown in Table 6-2. As shown, the demand has increased since 2015.

Table 6-2. Natural Gas Consumption in Imperial County 2015–2019

Year	Natural Gas Consumption (therms)
2019	42,914,053
2018	38,729,625
2017	40,442,318
2016	36,089,854
2015	31,494,256

Source: Appendix M of this EIR

Automotive Fuel Consumption

Automotive fuel consumption in Imperial County from 2016 to 2020 is shown in Table 6-3. As shown, fuel consumption has decreased between 2016 and 2020.

Table 6-3. Automotive Fuel Consumption in Imperial County 2016–2020

Year	Total Fuel Consumption (gallons)
2020	196,177,597
2019	198,822,094
2018	201,793,138
2017	204,312,157
2016	208,822,214

Source: Appendix M of this EIR

6.2.3 Proposed Project Energy Consumption

The project is proposing the development of a 100 MW alternating current PV energy generation system with an integrated 100 MW battery system. Operation of the proposed project would not result in the consumption of electricity or natural gas and thus, would not contribute to the County wide usage and would directly support the RPS goal of increasing the percentage of electricity procured from renewable sources.

Therefore, the energy analysis focuses on the two sources of energy that are most relevant to the project: the equipment fuel necessary for construction and the automotive fuel necessary for ongoing maintenance activities. The amount of total construction-related fuel use was estimated using ratios provided in the Climate Registry’s General Reporting Protocol for the Voluntary Reporting Program, Version 2.1. The amount of operational fuel use was estimated using CARB’s EMFAC2017 computer program, which provides projections for typical daily fuel usage in Imperial County. This analysis conservatively assumes that all of the automobile trips projected to arrive at the project site during operations would be new to Imperial County.

Energy consumption associated with the proposed project is summarized in Table 6-4. Project increases in automotive fuel consumption are compared with the countywide fuel consumption in 2020 (Table 6-3), the most recent full year of data.

Table 6-4. Proposed Project Energy and Fuel Consumption

Energy Type	Annual Energy Consumption	Percentage Increase Countywide
Electricity Consumption	0 kilowatt-hours	0.00000 percent
Natural Gas	0 therms	0.00000 percent
Automotive Fuel Consumption		
Project Construction 2022	77,931 gallons	0.03971 percent
Project Construction 2023	45,123 gallons	0.02299 percent
Project Operations	128 gallons	0.00006 percent

Source: Appendix M of this EIR

Notes: The project increases in electricity and natural gas consumption are compared with all uses in Imperial County in 2019, the latest data available. The project increases in automotive fuel consumption are compared with the countywide fuel consumption in 2020, the most recent full year of data.

Fuel necessary for project construction would be required for the operation and maintenance of construction equipment and the transportation of materials to the project site. The fuel expenditure necessary to construct the solar facility and infrastructure would be temporary, lasting only as long as project construction. As shown in Table 6-4, the project’s gasoline fuel consumption during the onetime construction period is estimated to be 77,931 gallons during 2022 construction and 45,123 gallons during 2023 construction. This would increase the annual countywide gasoline fuel use in the county by 0.03971 percent and 0.02299 percent, respectively. As such, project construction would have a nominal effect on local and regional energy supplies. No unusual project characteristics would necessitate the use of construction equipment that would be less energy efficient than at comparable construction sites in the region or the state. Construction contractors would purchase their own gasoline and diesel fuel from local suppliers and would judiciously use fuel supplies to minimize costs due to waste and subsequently maximize profits. Additionally, construction equipment fleet turnover and increasingly stringent state and federal regulations on engine efficiency combined with state regulations limiting engine idling times and requiring recycling of construction debris, would further reduce the amount of transportation fuel demand during project construction. For these reasons, it is

expected that construction fuel consumption associated with the project would not be any more inefficient, wasteful, or unnecessary than other similar development projects of this nature.

Once construction is completed the project would be remotely controlled. No employees would be based at the project site. The only operational emissions associated with the project would be associated with motor vehicle use for routine maintenance work and site security as well as panel upkeep and cleaning. A conservative estimate of one vehicle trip per day generated by the project was assumed. This is a conservative estimate as most days would require no operational related vehicle trips. As shown in Table 6-4, this would estimate to a consumption of approximately 128 gallons of automotive fuel per year, which would increase the annual countywide automotive fuel consumption by 0.00006 percent. Fuel consumption associated with both the construction equipment needed to construct the project and the vehicle trips generated by the project during ongoing maintenance activities would not be considered inefficient, wasteful, or unnecessary in comparison to other similar developments in the region. The proposed project would result in a less than significant impact related to energy.

6.2.4 Compliance with State or Local Plans for Renewable Energy or Energy Efficiency

The purpose of the proposed project is the construction of a renewable energy and storage facility in Imperial County. Once in operation, it will decrease the need for energy from fossil fuel-based power plants in the state. The result would be a net increase in electricity resources available to the regional grid, generated from a renewable source. Therefore, the project would directly support the RPS goal of increasing the percentage of electricity procured from renewable sources. Additionally, the project would also be consistent with the County's General Plan Conservation and Open Space Element, Objective 9.2 which encourages renewable energy developments. Therefore, the project would directly support state and local plans for renewable energy development. The proposed project would not conflict with or obstruct a state or local plan for renewable energy or energy efficiency; therefore, no impact would occur.

6.3 Mineral Resources

The project site is not used for mineral resource production and the applicant is not proposing any form of mineral extraction. According to Figure 8: Imperial County Existing Mineral Resources of the Conservation and Open Space Element of the General Plan (County of Imperial 2016), no known mineral resources occur within the project site nor does the project site contain mapped mineral resources. Therefore, the proposed project would not result in the loss of availability of any known mineral resources that would be of value to the region and the residents of California nor would the proposed project result in the loss of availability of a locally important mineral resource.

Based on a review of the California Department Division of Oil, Gas, and Geothermal Resources Well Finder, there is a plugged and abandoned well (Well No. 02590233) located in the north-central portion of the project site (APN 059-300-015) (California Department of Oil, Gas, and Geothermal Resources 2021). The well is located on a portion of the project site that would remain undeveloped (identified as non-usable land on the Site Plan [Figure 2-3]) and thereby avoided by the proposed project. Therefore, implementation of the proposed project would not impact any wells.

6.4 Population and Housing

Development of housing is not proposed as part of the project. No full-time employees are required to operate the project. The project facility will be monitored remotely. It is anticipated that maintenance of the facility will require minimal site presence to perform periodic visual inspections and minor repairs. On intermittent occasions, the presence of additional workers may be required for repairs or replacement of equipment and panel cleaning; however, due to the nature of the facility, such actions will likely occur infrequently. Therefore, the proposed project would not result in a substantial growth in the area, as the number of employees required to operate and maintain the facility is minimal.

No housing exists within the project site and no people reside within the project site. Therefore, the proposed project would not displace substantial numbers of people or housing, necessitating the construction of replacement housing elsewhere. The proposed project would result in no impact to population and housing.

6.5 Public Services

Fire Protection. Fire protection and emergency medical services in the area are provided by the Imperial County Fire Department. The project site is located in the unincorporated area of Imperial County. According to the Seismic and Public Safety Element of the General Plan (County of Imperial 1997), the potential for a major fire in the unincorporated areas of the County is generally low. Both the access and service roads (along the perimeter of the project facility) would have turnaround areas to allow clearance for fire trucks per fire department standards. Although the proposed project would be designed, constructed, and operated in accordance with applicable fire protection and other environmental, health, and safety requirements (e.g., CPUC safety standards), the project applicant will be required to consult and coordinate with the Fire Department to address any fire safety and service concerns (i.e. battery storage system fire prevention and control components), and emergency response site access, so that adequate service is maintained. While the proposed project may result in an increase in demand for fire protection service, with installation of internal fire prevention systems and ICFD consultation, including adherence to any special conditions regarding fire control and access, the project would not result in an increase in demand that would, in turn, result in a substantial adverse physical impact associated with the provision of new or physically altered fire protection facilities; the construction of which could cause significant environmental impacts, in order to maintain acceptable service ratios, response times, or other performance objectives for any of the public services. Based on these considerations, the project would not result in a need for fire facility expansion and a less than significant impact would occur.

Imperial County requires payment of impact fees for new development projects. Fire Impact Fees are imposed pursuant to Ordinance 1418 §2 (2006), which was drafted in accordance with the County's TischlerBise Impact Fee Study. The ordinance has provisions for non-residential industrial projects based on square footage. The project applicant will be required to pay the fire protection services' impact fees. These fees would be included in the Conditions of Approval for the CUP and would therefore be less than significant.

Police Protection. Police protection services in the project area is provided by the Imperial County Sheriff's Department. Although the potential is low, the proposed project may attract vandals or other security risks. The increase in construction related traffic could increase demand on law enforcement services. However, the project site would be fenced with 6-foot high chain link security fence and points of ingress/egress would be accessed via locked gates. In addition, periodic on-site personnel

visitations for security would occur during operations and maintenance of the proposed project, thereby minimizing the need for police surveillance. While the proposed project may result in a temporary increase in demand for law enforcement service, the project would not result in an increase in demand that would, in turn, result in a substantial adverse physical impact associated with the provision of new or physically altered sheriff facilities, the construction of which could cause significant environmental impacts, in order to maintain acceptable service ratios, response times or other performance objectives for any of the public services. Further, as conditions of approval of the project, the project applicant will be required to participate in the Imperial County Public Benefit Program for the life of this CUP and shall at all times be a party to a public benefit agreement in a form acceptable to County Counsel in order to pay for all costs, benefits, and fees associated with the approved project, and the applicant will be required to reimburse the Sheriff's Department for any investigations regarding theft on the project site and related law enforcement. Approval of this public benefit agreement will be required by the Board of Supervisors prior to the issuance of the first building permit. These potential impacts are less than significant.

Schools. The proposed project does not include the development of residential land uses that would result in an increase in population or student generation. Construction of the proposed project would not result in an increase in student population within the Imperial County's School District since it is anticipated that construction workers would commute in during construction operations. The proposed project would have no impact on Imperial County schools.

Parks and Other Public Facilities. No full-time employees are required to operate the project. The project facility will be monitored remotely. It is anticipated that maintenance of the facility will require minimal site presence to perform periodic visual inspections and minor repairs. Therefore, substantial permanent increases in population that would adversely affect local parks, libraries, and other public facilities are not expected. The project is not expected to have an impact on parks, libraries, and other public facilities.

6.6 Recreation

The project site is not used for formal recreational purposes. Also, the proposed project would not generate new employment on a long-term basis. As such, the project would not significantly increase the use or accelerate the deterioration of regional parks or other recreational facilities. The temporary increase of population during construction that might be caused by an influx of workers would be minimal and not cause a detectable increase in the use of parks. Additionally, the project does not include or require the expansion of recreational facilities. Therefore, no impact is identified for recreation.

6.7 Utilities and Service Systems

Wastewater Facilities. The project would generate a minimal volume of wastewater during construction. During construction activities, wastewater would be contained within portable toilet facilities and disposed of at an approved site. No habitable structures are proposed on the project site, such as O&M buildings; therefore, there would be no wastewater generation from the proposed project. The proposed project would not require or result in the relocation or construction of new or expanded wastewater facilities.

Storm Water Facilities. The proposed project will involve the construction of drainage control facilities within the project site, and included in the project impact footprint, of which environmental impacts have been evaluated. Otherwise, the project does not require expanded or new storm drainage

facilities off-site (i.e., outside of the project footprint) because the proposed solar facility would not generate a significant increase in the amount of impervious surface that would increase runoff during storm events, and therefore, would not require the construction of off-site storm water management facilities. Water from solar panel washing would continue to percolate through the ground, as a majority of the surfaces within the project site would remain pervious. The proposed project would not require or result in the relocation or construction of new or expanded storm water facilities beyond those proposed as part of the project and evaluated in the EIR.

Water Facilities. The proposed project is not anticipated to result in a significant increase in water demand/use during operation; however, water will be needed for solar panel washing and dust suppression. During operation, water would be trucked to the project site from a local water source. Therefore, the proposed project would not require or result in the relocation or construction of new or expanded water facilities.

Power, Natural Gas, and Telecommunication Facilities. The proposed project would involve construction of power facilities. However, these are components of the project as evaluated in the EIR. The proposed project would not otherwise generate the demand for or require or result in the relocation or construction of new or expanded electric power, natural gas, or telecommunications facilities that would in turn, result in a significant impact to the environment.

Solid Waste Facilities. Solid waste generation would be minor for the construction and operation of the project. Solid waste would be disposed of using a locally-licensed waste hauling service, most likely Allied Waste. Trash would likely be hauled to the Calexico Solid Waste Site (13-AA-0004) located approximately 13 miles west of the proposed project in Calexico. As of August 1, 2019, the Calexico Solid Waste Site has approximately 1,561,235 cubic yards of remaining capacity and is estimated to remain in operation through 2179 (CalRecycle 2021). Therefore, there is ample landfill capacity in the County to receive the minor amount of solid waste generated by construction and operation of the proposed project.

Additionally, because the proposed project would generate solid waste during construction and operation, the project would be required to comply with state and local requirements for waste reduction and recycling; including the 1989 California Integrated Waste Management Act and the 1991 California Solid Waste Reuse and Recycling Access Act of 1991. Also, conditions of the CUP would contain provisions for recycling and diversion of Imperial County construction waste policies.

Further, when the proposed project reaches the end of its operational life, the components would be decommissioned and deconstructed. When the project concludes operations, much of the wire, steel, and modules of which the system is comprised would be recycled to the extent feasible. The project components would be deconstructed and recycled or disposed of safely, and the site could be converted to other uses in accordance with applicable land use regulations in effect at the time of closure. Commercially reasonable efforts would be used to recycle or reuse materials from the decommissioning. All other materials would be disposed of at a licensed facility. A less than significant impact is identified for this issue.

6.8 Wildfire

According to the Draft Fire Hazard Severity Zone Map for Imperial County prepared by the California Department of Forestry and Fire Protection, the project site is not located in or near state responsibility areas or lands classified as very high hazard severity zones (California Department of Forestry and Fire Protection 2007). Therefore, the proposed project would not substantially impair an adopted emergency response plan or emergency evacuation plan; expose project occupants to, pollutant

concentrations from a wildfire or the uncontrolled spread of a wildfire; exacerbate fire risk; or expose people or structures to significant risks, including downslope or downstream flooding or landslides, as a result of runoff, post-fire slope instability, or drainage changes. No impact is identified for wildfire.

7 Alternatives

7.1 Introduction

The identification and analysis of alternatives is a fundamental concept under CEQA. This is evident in that the role of alternatives in an EIR is set forth clearly and forthrightly within the CEQA statutes. Specifically, CEQA §21002.1(a) states:

“The purpose of an environmental impact report is to identify the significant effects on the environment of a project, to identify alternatives to the project, and to indicate the manner in which those significant effects can be mitigated or avoided.”

The CEQA Guidelines require an EIR to “describe a range of reasonable alternatives to the project, or to the location of the project, which would feasibly attain most of the basic objectives of the project but would avoid or substantially lessen any of the significant effects of the project and evaluate the comparative merits of the alternatives” (CEQA Guidelines §15126.6(a)). The CEQA Guidelines direct that selection of alternatives focus on those alternatives capable of eliminating any significant environmental effects of the project or of reducing them to a less-than significant level, even if these alternatives would impede to some degree the attainment of project objectives or would be more costly. In cases where a project is not expected to result in significant impacts after implementation of recommended mitigation, review of project alternatives is still appropriate.

The range of alternatives required within an EIR is governed by the “rule of reason” which requires an EIR to include only those alternatives necessary to permit a reasoned choice. The discussion of alternatives need not be exhaustive. Furthermore, an EIR need not consider an alternative whose implementation is remote and speculative or whose effects cannot be reasonably ascertained.

Alternatives that were considered but were rejected as infeasible during the scoping process should be identified along with a reasonably detailed discussion of the reasons and facts supporting the conclusion that such alternatives were infeasible.

Based on the alternatives analysis, an environmentally superior alternative is designated among the alternatives. If the environmentally superior alternative is the No Project Alternative, then the EIR shall identify an environmentally superior alternative among the other alternatives (CEQA Guidelines §15126.6(e)(2)).

7.2 Criteria for Alternatives Analysis

As stated above, pursuant to CEQA, one of the criteria for defining project alternatives is the potential to attain the project objectives. Established objectives of the project applicant for the proposed project include:

- Construct and operate a solar energy facility capable of producing up to 100-megawatt (MW) alternating current (AC) of electricity to assist the State of California in achieving its 60 percent renewable portfolio standard by 2030.
- Provide a 100 MW energy (battery storage) system, that would accommodate and store the power generated by the project so that the facility can continue to provide renewable energy during non-daylight hours.

- Interconnect directly to IID’s existing electrical transmission system.
- Help California meet its statutory and regulatory goal of increasing renewable power generation, including greenhouse gas reduction goals of Senate Bill 32.
- Minimize and mitigate any potential impact to sensitive environmental resources within the project area.

7.3 Alternatives Considered but Rejected

7.3.1 Alternative Site

Section 15126.6(f)(2) of the CEQA Guidelines addresses alternative locations for a project. The key question and first step in the analysis is whether any of the significant effects of the proposed project would be avoided or substantially lessened by constructing the proposed project in another location. Only locations that would avoid or substantially lessen any of the significant effects of the project need to be considered for inclusion in the EIR. Further, CEQA Guidelines Section 15126.6(f)(1) states that among the factors that may be considered when addressing the feasibility of alternative locations are whether the project proponent can reasonably acquire, control or otherwise have access to the alternative site (or the site is already owned by the proponent).

The proponent does not have control of an alternate site; if control were viable, the proponent would have to re-initiate the application process as a new project. Similar to the proposed project site, an alternate site would require environmental review once the proponent has prepared sufficient project description information. At present, the proponent does not have control of an alternate site. This alternative would be the most complex, costly, and time-consuming alternative to implement. It is unknown if the environmental impacts associated with this Alternative would be less than the proposed project because it would be speculative to evaluate an unsecured alternate site. This is primarily due to the fact that the proponent does not have control of an alternate site. Therefore, an alternative site was eliminated from further consideration in this EIR.

7.3.2 Original Site Plan Submittal

The project applicant originally proposed to construct and operate a 100 MW solar energy facility with an integrated 100 MW battery storage system on approximately 531 acres (APNs 059-290-010, 059-300-015, and 059-300-017). Based on a biological reconnaissance survey of the 531-acre site, the following sensitive vegetation communities were found to be present on the western parcel (APN 059-209-010): arrow weed thickets, tamarisk thickets, and alkali weed – salt grass playas and sinks. Furthermore, one freshwater emergent wetland occurs on the western parcel. To minimize impacts on biological resources, the project applicant re-designed the project to remove the western parcel (APN 059-209-010). The western parcel would not be developed. This re-design reduced the original project site from 531 acres to 450 acres.

The original site plan on 531 acres would result in increased biological resources impacts and increased jurisdictional water impacts compared to the proposed project. Therefore, the County rejects to original site plan from further analysis.

7.3.3 Original Access Route for Heavy Construction Equipment

The project applicant’s originally proposed access route for heavy construction equipment was via State Route 98 east to the East Highline Check of the All-American Canal bridge crossing to the project

entrance. After coordination with the IID, IID determined that the bridge crossing would not be able to handle the weight of heavy construction equipment.

Although the use of the original access route would be a shorter distance to the project site and would result in less miles traveled, the County rejects the original access route from further analysis due to increased hazards and safety impacts.

7.4 Alternative 1: No Project/No Development Alternative

The CEQA Guidelines require analysis of the No Project Alternative (PRC Section 15126). According to Section 15126.6(e)(1), “the specific alternative of ‘no project’ shall also be evaluated along with its impact.” Also, pursuant to Section 15126.6(e)(2); “The ‘no project’ analysis shall discuss the existing conditions at the time the notice of preparation is published, ... at the time environmental analysis is commenced, as well as what would be reasonably expected to occur in the foreseeable future if the project were not approved, based on current plans and consistent with available infrastructure and community services.”

The No Project/No Development Alternative assumes that the project, as proposed, would not be implemented and the project site would not be further developed with a solar energy project. The No Project/No Development Alternative would fail to meet any of the project objectives.

7.4.1 Environmental Impact of Alternative 1: No Project/No Development Alternative

Aesthetics and Visual Resources

Under the No Project/No Development Alternative, the project site would not be developed and would continue to be undeveloped, partially disturbed land. The No Project/No Development Alternative would not modify the existing project site or add construction to the project site therefore, there would be no change to the existing condition of the site. Under this alternative, there would be no potential to create a new source of light or glare associated with the PV arrays. A less than significant aesthetic impact (including potential light and glare impact) has been identified associated with the project. However, because there would be no change to the existing condition of the project site under this alternative, there would be no potential impact associated with a change in visual character of the site and the potential aesthetic impact would be less as compared to the project as the existing visual conditions would not change.

Agricultural Resources

Under the No Project/No Development Alternative, the project site would not be developed and continue to be undeveloped, partially disturbed land. Compared to the proposed project, implementation of this alternative would avoid the temporary conversion of land designated as Other Land and Farmland of Local Importance per the Farmland Mapping and Monitoring Program (FMMP) to non-agricultural uses. However, as previously indicated, these designations are not considered an “agricultural land” per CEQA Statute Section 21060.1(a). Therefore, this alternative would not contribute to the conversion of agricultural lands or otherwise adversely affect agricultural operations. Compared to the proposed project, this alternative would avoid the need for future restoration of the project site to pre-project conditions.

Air Quality

Under the No Project/No Development Alternative, there would be no air emissions associated with project construction or operation, and no project- or cumulative-level air quality impact would occur. Therefore, no significant impacts to air quality or violation of air quality standards would occur under this alternative. Moreover, this alternative would be consistent with existing air quality attainment plans and would not result in the creation of objectionable odors.

As discussed in Section 3.4, Air Quality, the proposed project would not exceed the ICAPCD's significance thresholds for emissions of ROG, CO, NO_x, and PM_{2.5} during both the construction and operational phases of the project. However, the project would exceed the ICAPCD threshold for PM₁₀. Pursuant to ICAPCD, all construction sites, regardless of size, must comply with the requirements contained within Regulation VIII – Fugitive Dust Control Measures. The project must comply with the requirements of ICAPCD Regulation VIII for the control of fugitive dust (Mitigation Measure AQ-1). With the implementation of the ICAPCD Regulation VIII requirements (Mitigation Measure AQ-1), the project would not exceed the ICAPCD's thresholds of significance for PM₁₀ emissions. This alternative would result in less air quality emissions compared to the proposed project, the majority of which would occur during construction. The No Project/No Development Alternative would not reduce the long-term need for renewable electricity generation. As a consequence, while the No Project/No Development Alternative would not result in new impacts to air quality as a result of construction, it would likely not realize the overall benefits to regional air quality when compared to the operation of the proposed project.

Biological Resources

Under the No Project/No Development Alternative, existing biological resource conditions within the project site would largely remain unchanged and no impact would be identified. Unlike the proposed project which requires mitigation for biological resources including Abram's spurge, burrowing owl, and other migratory birds, this alternative would not result in construction of a solar facility that could otherwise result in significant impacts to these biological resources. Compared to the proposed project, this alternative would avoid impacts to biological resources.

Cultural Resources

The proposed project would involve ground-disturbing activities that have the potential to impact known historical resources and disturb previously undocumented cultural resources that could qualify as historical resources or unique archaeological resources pursuant to CEQA. Under the No Project/No Development Alternative, the project site would not be developed and no construction-related ground disturbance would occur. Therefore, compared to the proposed project, this alternative would avoid impacts to cultural resources.

Geology and Soils

Because there would be no development at the project site under the No Project/No Development Alternative, no grading or construction of new facilities would occur. Therefore, there would be no impact to project-related facilities as a result of local seismic hazards (strong ground shaking), liquefaction, lateral spreading, collapsible soils, expansive soils, corrosive soils, soil erosion, and paleontological resources. In contrast, the proposed project would require the incorporation of mitigation measures related to strong ground shaking, liquefaction, collapsible soils, expansive soils, corrosive soils, soil erosion, and paleontological resources to minimize impacts to a level less than

significant. Compared to the proposed project, this alternative would avoid significant impacts related to local geology and soil conditions and paleontological resources.

Greenhouse Gas Emissions

Under the No Project/No Development Alternative, there would be no GHG emissions resulting from project construction or operation or corresponding impact to global climate change. The No Project/No Development Alternative would not help California meet its statutory and regulatory goal of increasing renewable power generation, including GHG reduction goals of SB 32. While this alternative would not further implement policies for GHG reductions, this alternative would also not directly conflict with any applicable plan, policy, or regulation adopted for the purpose of reducing the emissions of GHGs. This alternative would not create any new GHG emissions during construction but would not lead to a long-term beneficial impact to global climate change by providing renewable clean energy. For the proposed project, a less than significant impact was identified for construction-related GHG emissions, and in the long-term, the project would result in an overall beneficial impact to global climate change as the result of creation of clean renewable energy, that does not generate GHG emissions. Compared to the proposed project, while the No Project/No Development Alternative would not result in new GHG emissions during construction, it would be less beneficial to global climate change as compared to the proposed project. Further, the construction emissions (amortized over 30 years) associated with the project would be off-set by the beneficial renewable energy provided by the project, negating any potential that the No Project/No Development alternative would reduce construction-related GHG emissions.

Hazards and Hazardous Materials

The No Project/No Development Alternative would not include any new construction. Therefore, no potential exposure to hazardous materials would occur. Therefore, no impact is identified for this alternative for hazards and hazardous materials. As with the proposed project, this alternative would not result in safety hazards associated with airport operations. Although a less than significant impact is identified for hazards and hazardous materials associated with the project, compared to the proposed project, this alternative would have less of an impact related to hazards and hazardous materials as there would be no potential for the transport, use, removal or disposal of hazardous materials.

Hydrology/Water Quality

The No Project/No Development Alternative would not result in modifications to the existing drainage patterns or volume of storm water runoff as attributable to the proposed project, as the existing site conditions and on-site pervious surfaces would remain unchanged. In addition, no changes with regard to water quality would occur under this alternative. Compared to the proposed project, from a drainage perspective, this alternative would avoid changes to existing hydrology. Under this alternative, there would be no water demand. This alternative would have less of an impact associated with hydrology/water quality as compared to the proposed project.

Land Use Planning

Under the No Project/No Development Alternative, the project site would not be developed and continue to be undeveloped, partially disturbed land. Current land uses would remain the same. No existing community would be divided, and no inconsistencies with land use planning policies would occur. Because no significant Land Use and Planning impact has been identified associated with the

proposed project, this alternative would not avoid or reduce a significant impact related to this issue and therefore, it is considered similar to the proposed project.

Noise

This alternative would not require construction or operation of the project facilities; therefore, this alternative would not increase ambient noise levels within the vicinity of the project site. For this reason, no significant noise impacts would occur. As discussed in Section 3.12, Noise and Vibration, the proposed project would not result in significant noise impacts to sensitive receptors during construction and operation. Compared to the proposed project, this alternative would not generate noise and would have less of an impact associated with noise.

Transportation

There would be no new development under the No Project/No Development Alternative. Therefore, this alternative would not generate vehicular trips during construction or operation. For these reasons, no impact would occur and this alternative would not impact any applicable plan, ordinance, or policy addressing the performance of the circulation system, substantially increase hazards because of a design feature, or result in inadequate emergency access. Although the proposed project would result in less than significant transportation impacts, this alternative would avoid an increase in vehicle trips on local roadways, and any safety related hazards that could occur in conjunction with the increase vehicle trips and truck traffic, primarily associated with the construction phase of the project.

Tribal Cultural Resources

The proposed project is not anticipated to cause a substantial adverse change in the significance of a tribal cultural resource. Impacts to tribal cultural resources under the No Project/No Development Alternative are similar to the proposed project.

Utilities and Service Systems

The No Project/No Development Alternative would not require the expansion or extension of existing utilities, since there would be no new project facilities that would require utility service. No solid waste would be generated under this alternative. The proposed project would not result in any significant impacts to existing utilities or solid waste facilities. Compared to the proposed project, this alternative would have less of an impact related to utilities and solid waste facilities.

Conclusion

Implementation of the No Project/No Development Alternative would generally result in reduced impacts for a majority of the environmental issues areas considered in Chapter 3, Environmental Analysis when compared to the proposed project. A majority of these reductions are realized in terms of significant impacts that are identified as a result of project construction. However, this alternative would not realize the benefits of reduced GHG emissions associated with energy use, which are desirable benefits that are directly attributable to the proposed project.

Comparison of the No Project/No Development Alternative to Project Objectives

The No Project/No Development Alternative would not meet any of the objectives of the project. Additionally, the No Project/No Development Alternative would not help California meet its statutory

and regulatory goal of increasing renewable power generation, including GHG reduction goals of SB 32.

7.5 Alternative 2: Reduced Project Site

The purpose of this alternative is to reduce the size of the project site to minimize impacts on biological resources by increasing the setback of the project from sensitive vegetation communities and aquatic resources. Tamarisk thickets, identified by CDFW as a sensitive natural community, have been mapped on the northern parcel (APN 059-300-015) of the project site. Freshwater forested/shrub wetland, riparian habitat, and disturbed riparian habitat have also been mapped on the northern parcel of the project site. This alternative would remove the northern parcel (APN 059-300-015), thereby reducing the project site by 301 acres from 450 acres to 149 acres.

7.5.1 Environmental Impact of Alternative 2: Reduced Project Site

Aesthetics and Visual Resources

Under Alternative 2, the overall size of the solar energy facility would be reduced. No significant visual aesthetic impact has been identified as the proposed project's facilities would not impact scenic resources, result in the substantial degradation of the existing visual character of the project site or add a substantial amount of light and glare. As such, this alternative would not avoid or reduce any significant impacts identified for the project and the aesthetic impact would be similar to the proposed project.

Agricultural Resources

Under Alternative 2, the overall size of the solar energy facility would be reduced. This alternative would reduce the temporary conversion of land designated as Other Land and Farmland of Local Importance. However, as previously indicated, these designations are not considered an "agricultural land" per CEQA Statute Section 21060.1(a). Therefore, similar to the proposed project, this alternative would not contribute to the conversion of agricultural lands or otherwise adversely affect agricultural operations. Similar to the proposed project, the need for future restoration of the project site to pre-project conditions would be required under this alternative.

Air Quality

Under Alternative 2, air emissions during construction would be less than the proposed project because of the reduced site development. A less than significant impact with mitigation incorporated has been identified for the proposed project during construction. Similar to the proposed project, this alternative would be required to comply with the requirements of ICAPCD Regulation VIII for the control of fugitive dust. Similar to the proposed project, this alternative would be consistent with existing AQAPs and would not result in the creation of objectionable odors. This alternative would provide less MW generation compared to the proposed project, thereby reducing its ability to provide a long-term source of renewable energy. Compared to the proposed project, while this alternative would result in less air quality impacts, it would likely provide fewer desirable benefits to overall regional air quality as attributable to the proposed project.

Biological Resources

Under Alternative 2, the overall size of the solar energy facility would be reduced by 301 acres. Under Alternative 2, impacts on biological resources would be reduced by increasing the setback of the project from sensitive vegetation communities (tamarisk thickets) and aquatic resources (freshwater forested/shrub wetland, riparian habitat, and disturbed riparian habitat). Although the overall size of the solar energy facility would be reduced, there is still potential for impacts on special-status species such as Abram's spurge and burrowing owl. Compared to the proposed project, this alternative would result in a reduction in impacts on biological resources but would still require mitigation.

Cultural Resources

Although the overall size of the solar energy facility would be reduced by 301 acres, this alternative would still require ground-disturbing activities, which has the potential to disturb undocumented cultural resources that could qualify as historical resources or unique archaeological resources pursuant to CEQA, and human remains. Compared to the proposed project, this alternative would result in a reduction in impacts on cultural resources because of the reduced site development but would still require mitigation.

Geology and Soils

Under Alternative 2, while the overall project footprint would be reduced, grading and construction of new facilities, such as the solar facility, battery energy storage, and gen-tie, would still occur. This alternative would still be subject to potential impacts related to strong ground shaking, liquefaction, soil erosion, collapsible soils, expansive soils, and paleontological resources, and would require the incorporation of mitigation measures to minimize these impacts to a less than significant level. This alternative would result in similar geology and soil and paleontological resources impacts as the proposed project.

Greenhouse Gas Emissions

Under Alternative 2, the overall project footprint would be reduced by approximately 301 acres thereby contributing to reductions in GHG emissions during project construction. However, as a consequence of the reduced size of the project, this alternative would result in a reduced power production capacity as compared to the proposed project; hence, the overall benefits of the project to global climate change through the creation of renewable energy would also be reduced. This alternative would not conflict with any applicable plan, policy, or regulation adopted for the purpose of reducing GHG emissions. Similar to the proposed project, this alternative would not exceed MDAQMD's threshold of 100,000 MTCO₂e. Compared to the proposed project, this alternative would contribute to similar and desirable reductions in GHG emissions and associated contribution to global climate change through the production of renewable energy, although to a lesser degree. Because no significant GHG impact has been identified associated with the proposed project, this alternative would not avoid or reduce a significant impact related to this issue and, therefore, it is considered similar to the proposed project.

Hazards and Hazardous Materials

Similar to the proposed project, construction of this alternative would involve the limited use of hazardous materials, such as fuels and greases to fuel and service construction equipment. Also, as with the proposed project, because the Phase I ESA prepared for the proposed project did not identify and on-site RECs, ASTs, or USTs, this alternative would not avoid or reduce impacts associated with

hazardous materials. Further, no impact associated with potential safety hazards to the public residing or working within proximity to a public airport would occur. Implementation of this alternative would result in a similar hazards and hazardous materials impact as the proposed project. This alternative would not avoid or lessen the impact to hazards and hazardous materials as no significant impact associated with the proposed project has been identified.

Hydrology/Water Quality

Alternative 2 would result in modifications to the existing drainage patterns and the volume of storm water runoff, as this alternative would introduce impervious area on-site, although to a lesser degree than the proposed project. Because the overall project footprint would be reduced, this alternative would realize a minor reduction in the corresponding impacts on hydrology and on-site drainage; however, the same mitigation measures would be applicable to this alternative. Similar to the proposed project, no impacts would result from flooding and facilities will not be placed within floodplains. Compared to the proposed project, this alternative would result in less of an impact on hydrology/water quality.

Land Use Planning

Implementation of this alternative would not avoid or reduce a land use and planning impact, as no significant impact associated with the project has been identified. As with the proposed project, this alternative would be consistent with the County Land Use Ordinance, Division 17, RE Overlay Zone, which authorizes the development and operation of RE projects with an approved CUP. Implementation of this alternative would be similar to the proposed project with respect to land use and planning.

Noise

As with the proposed project, Alternative 2 would not result in significant noise impacts associated with construction activities. As with the proposed project, operational impacts associated with this alternative would not expose persons or generate noise levels in excess of applicable noise standards, exposure persons to, or generate excessive groundborne vibration, or expose persons to excessive aircraft noise. Because no significant noise impact has been identified associated with the proposed project, this alternative would not avoid or reduce a significant impact related to this issue and therefore, it is considered similar to the proposed project.

Transportation

This alternative would result in a similar level of construction and operation-related vehicle and truck trips as compared to the proposed project. However, the increase in vehicular traffic was identified as a less than significant impact for the proposed project. In this context, Alternative 2 would not reduce or avoid an impact related to transportation and would result in less than significant impacts similar to the proposed project. As with the proposed project, Alternative 2 would not impact any applicable plan, ordinance, or policy addressing the performance of the circulation system, substantially increase hazards because of a design feature, result in inadequate emergency access, or conflict with public transit, bicycle, or pedestrian facilities. This alternative would result in a similar impact related to transportation as the proposed project.

Tribal Cultural Resources

Implementation of this alternative would not avoid or reduce a tribal cultural resources impact, as no significant impact associated with the project has been identified. Impacts to tribal cultural resources under this alternative are similar to the proposed project.

Utilities and Service Systems

Implementation of this alternative would result in an overall less demand for utilities, including water. However, this alternative would not avoid or reduce a significant impact associated with the project as a less than significant impact to utilities has been identified associated with the project. Implementation of this alternative would not achieve to the same degree the beneficial impacts of providing renewable energy. As compared to the proposed project, the overall demand for utilities would be less under this alternative.

Conclusion

As shown on Table 7-1, this alternative would reduce impacts to agricultural resources, air quality, biological resources, cultural resources, hydrology/water quality, and utilities/service systems.

Comparison of Alternative 2: Reduced Project Site

Alternative 2 would meet most of the basic objectives of the proposed project and should remain under consideration. However, this alternative would make it more difficult to achieve the overall objective of providing a total of 100 MW of renewable solar energy, as there would be less area available for the placement of PV structures.

7.6 Environmentally Superior Alternative

Table 7-1 provides a qualitative comparison of the impacts for each alternative compared to the proposed project. As noted on Table 7-1, the No Project/No Development Alternative would be considered the environmentally superior alternative, since it would eliminate all of the significant impacts identified for the project. However, CEQA Guidelines Section 15126.6(e)(2) states that “if the environmentally superior alternative is the No Project Alternative, the EIR shall also identify an environmentally superior alternative among the other alternatives.” As shown on Table 7-1, Alternative 2 would reduce impacts for the following environmental issue areas as compared to the proposed project: agricultural resources, air quality, biological resources, cultural resources, hydrology/water quality, and utilities/service systems. Therefore, Alternative 2 is considered the Environmentally Superior Alternative.



Table 7-1. Comparison of Alternative Impacts to Proposed Project

Environmental Issue Area	Proposed Project	Alternative 1: No Project/No Development	Alternative 2: Reduced Project Site
Aesthetics and Visual Resources	Less than Significant	<i>CEQA Significance:</i> No Impact <i>Comparison to Proposed Project:</i> Less Impact	<i>CEQA Significance:</i> Less than Significant <i>Comparison to Proposed Project:</i> Similar Impact
Agricultural Resources	Less than Significant with Mitigation	<i>CEQA Significance:</i> No Impact <i>Comparison to Proposed Project:</i> Less Impact (Avoid)	<i>CEQA Significance:</i> Less than Significant with Mitigation <i>Comparison to Proposed Project:</i> Less Impact
Air Quality	Less than Significant with Mitigation	<i>CEQA Significance:</i> No Impact <i>Comparison to Proposed Project:</i> Less Impact	<i>CEQA Significance:</i> Less than Significant with Mitigation <i>Comparison to Proposed Project:</i> Less Impact
Biological Resources	Less than Significant with Mitigation	<i>CEQA Significance:</i> No Impact <i>Comparison to Proposed Project:</i> Less Impact (Avoid)	<i>CEQA Significance:</i> Less than Significant with Mitigation <i>Comparison to Proposed Project:</i> Less Impact
Cultural Resources	Less than Significant with Mitigation	<i>CEQA Significance:</i> No Impact <i>Comparison to Proposed Project:</i> Less Impact (Avoid)	<i>CEQA Significance:</i> Less than Significant with Mitigation <i>Comparison to Proposed Project:</i> Less Impact

Table 7-1. Comparison of Alternative Impacts to Proposed Project

Environmental Issue Area	Proposed Project	Alternative 1: No Project/No Development	Alternative 2: Reduced Project Site
Geology and Soils	Less than Significant with Mitigation	<i>CEQA Significance:</i> No Impact <i>Comparison to Proposed Project:</i> Less Impact (Avoid)	<i>CEQA Significance:</i> Less than Significant with Mitigation <i>Comparison to Proposed Project:</i> Similar Impact
GHG Emissions	Less than Significant	<i>CEQA Significance:</i> No Impact <i>Comparison to Proposed Project:</i> Less Impact	<i>CEQA Significance:</i> Less than Significant <i>Comparison to Proposed Project:</i> Similar Impact
Hazards and Hazardous Materials	Less than Significant	<i>CEQA Significance:</i> No Impact <i>Comparison to Proposed Project:</i> Less Impact	<i>CEQA Significance:</i> Less than Significant <i>Comparison to Proposed Project:</i> Similar Impact
Hydrology/ Water Quality	Less than Significant with Mitigation	<i>CEQA Significance:</i> No Impact <i>Comparison to Proposed Project:</i> Less Impact (Avoid)	<i>CEQA Significance:</i> Less than Significant with Mitigation <i>Comparison to Proposed Project:</i> Less Impact
Land Use/Planning	No Impact	<i>CEQA Significance:</i> No Impact <i>Comparison to Proposed Project:</i> Similar Impact	<i>CEQA Significance:</i> No Impact <i>Comparison to Proposed Project:</i> Similar Impact



Table 7-1. Comparison of Alternative Impacts to Proposed Project

Environmental Issue Area	Proposed Project	Alternative 1: No Project/No Development	Alternative 2: Reduced Project Site
Noise and Vibration	Less than Significant	<i>CEQA Significance:</i> No Impact <i>Comparison to Proposed Project:</i> Less Impact	<i>CEQA Significance:</i> Less than Significant <i>Comparison to Proposed Project:</i> Similar Impact
Transportation	Less than Significant	<i>CEQA Significance:</i> No Impact <i>Comparison to Proposed Project:</i> Less Impact	<i>CEQA Significance:</i> Less than Significant <i>Comparison to Proposed Project:</i> Similar Impact
Tribal Cultural Resources	Less than Significant	<i>CEQA Significance:</i> No Impact <i>Comparison to Proposed Project:</i> Less Impact	<i>CEQA Significance:</i> Less than Significant <i>Comparison to Proposed Project:</i> Similar Impact
Utilities/Service Systems	Less than Significant	<i>CEQA Significance:</i> No Impact <i>Comparison to Proposed Project:</i> Less Impact	<i>CEQA Significance:</i> Less than Significant <i>Comparison to Proposed Project:</i> Less Impact

This page is intentionally blank.



8 References

- Avian Powerline Interaction Committee (APLIC). 1996. Suggested Practices for Raptor Protection on Power Lines.
- . 2012. Reducing Avian Collisions with Power Lines. Available on-line at: https://www.aplic.org/uploads/files/15518/Reducing_Avian_Collisions_2012watermarkLR.pdf.
- . 2020. California Greenhouse Gas Inventory for 2000–2018 – by Category as Defined in the 2008 Scoping Plan. https://ww3.arb.ca.gov/cc/inventory/data/tables/ghg_inventory_scopingplan_sum_2000-18.pdf.
- . 2016. Ambient Air Quality Standards. Available on-line at https://ww2.arb.ca.gov/sites/default/files/2020-03/aaqs2_0.pdf.
- CARB. 2017. Climate Change Scoping Plan. Accessed, April 28, 2021. <https://ww2.arb.ca.gov/our-work/programs/ab-32-climate-change-scoping-plan/2017-scoping-plan-documents>.
- California Department of Conservation (DOC). 2021. California Important Farmland Finder. Available on-line at <https://maps.conservation.ca.gov/DLRP/CIFF/>. Accessed on April 28, 2021.
- . 2018. Alternate Imperial County 2016–2018 Land Use Conversation Table A-9.
- . 2016. Imperial County Williamson Act FY 2016/2017.
- California Department of Fish and Game. 2012. *Staff Report on Burrowing Owl Mitigation*. March 7, 2012.
- California Department of Forestry and Fire Protection. 2007. Fire Hazard Severity Zones in SRA – Imperial County. Adopted by CALFIRE on November 7, 2007.
- California Department of Oil, Gas, and Geothermal Resources. 2021. Geologic Energy Management Division’s Well Finder. Available online at <https://maps.conservation.ca.gov/doggr/wellfinder/#openModal/-118.94276/35.22235/6>. Accessed on April 30, 2021.
- California Native Plant Society. 2001. *Inventory of Rare and Endangered Plants of California* (sixth edition). Rare Plant Scientific Advisory Committee, David P. Tibor, Convening Editor. California Native Plant Society, Sacramento, CA. 388 pp.
- CalRecycle. 2021. SWIS Facility/Site Activity Details – Calexico Solid Waste Site (13-AA-0004). Available online at <https://www2.calrecycle.ca.gov/SolidWaste/SiteActivity/Details/4179?siteID=591>. Accessed on April 30, 2021.
- Caltrans. 2020. Transportation and Construction Vibration Guidance Manual. Available online at <https://dot.ca.gov/-/media/dot-media/programs/environmental-analysis/documents/env/tcvgm-apr2020-a11y.pdf>.
- California Department of Water Resources. 2004. California’s Groundwater Bulletin 118. Imperial Valley Groundwater Basin. Available online at <https://water.ca.gov/-/media/DWR-Website/>

[Web-Pages/Programs/Groundwater-Management/Bulletin-118/Files/2003-Basin-Descriptions/7_030_ImperialValley.pdf](#).

California Natural Resources Agency. 2018. A Summary of Key Findings from California's Fourth Climate Change Assessment. https://www.energy.ca.gov/sites/default/files/2019-11/20180827_Summary_Brochure_ADA.pdf.

California Regional Water Quality Control Board (RWQCB). 2019. Water Quality Control Plan for the Colorado River Basin Region.

County of Imperial. 2020. Land Use Ordinance. Title 9. Division 5: Zoning Areas Established. <https://www.icpds.com/assets/5-Zoning-Areas-Established-.pdf>.

——— 2016. Conservation and Open Space Element.

——— 2015. Agricultural Element.

——— 2008. Circulation and Scenic Highways Element.

——— 1997. Seismic and Public Safety Element.

——— 1996. Airport Land Use Compatibility Plan, Imperial County Airports.

Federal Emergency Management Agency (FEMA). 2008. Flood Insurance Rate Map, Map Number Panel 06025C2125C. Effective Date September 26, 2008.

FTA. 2018. Transit Noise and Vibration Impact Assessment. Available online at: https://www.transit.dot.gov/sites/fta.dot.gov/files/docs/research-innovation/118131/transit-noise-and-vibration-impact-assessment-manual-fta-report-no-0123_0.pdf.

Imperial County Air Pollution Control District (ICAPCD). 2018a. 2018 Redesignation Request and Maintenance Plan for Particulate Matter Less than 10 Microns in Diameter. Adopted October 23, 2018.

——— 2018b. 2018 Annual Particulate Matter Less than 2.5 Microns in Diameter State Implementation Plan. April 2018.

——— 2009. Final 2009 Imperial County State Implementation Plan for Particulate Matter Less than 10 Microns in Aerodynamic Diameter. August 11, 2009.

——— 2017a. 2017 State Implementation Plan for the 2008 8-Hour Ozone Standard. September 2017.

——— 2017b. CEQA Air Quality Handbook. As amended December 12, 2017.

——— 2014. Final 2013 State Implementation Plan for the 2006 24-Hour PM_{2.5} Moderate Nonattainment Area. December 2, 2014.

Imperial County Agricultural Commissioner. 2019. 2019 Imperial County Agricultural Crop & Livestock Report.

Imperial County Office of Emergency Services (OES). 2016. Imperial County Emergency Operations Plan.

Imperial Valley Transit. 2021. About Us. Available on-line at: <https://www.ivtransit.com/about-us>. Accessed December 21, 2021.

- Natural Resources Agency (NRA). 2018. Technical Advisory on Evaluating Transportation Impacts in CEQA. https://opr.ca.gov/docs/20190122-743_Technical_Advisory.pdf.
- Regional Water Quality Control Board. 2018. *2018 California Integrated Report: Appendix A, 303(d) List of Impaired Waterbodies*. Accessed January 12, 2022. https://www.waterboards.ca.gov/water_issues/programs/water_quality_assessment/2018_integrated_report.html.
- Southern California Association of Governments (SCAG). 2020. 2020–2045 Regional Transportation Plan/Sustainable Communities Strategy (Connect SoCal). <https://scag.ca.gov/connect-socal>.
- State of California Employment Development Department. 2022. Immediate Release, El Centro Metropolitan Statistical Area (MSA) (Imperial County). October 21, 2022.
- U.S. Environmental Protection Agency. 2016. Final Rulemaking to Establish Greenhouse Gas Emissions Standards and Fuel Efficiency Standards for Medium- and Heavy-Duty Engines and Vehicles – Phase 2. October 25, 2016. Available online at <https://www.govinfo.gov/content/pkg/FR-2016-10-25/pdf/2016-21203.pdf>.
- . 2011. Final Rulemaking to Establish Greenhouse Gas Emissions Standards and Fuel Efficiency Standards for Medium- and Heavy-Duty Engines and Vehicles. September 5, 2011. Available online at: <https://www.govinfo.gov/content/pkg/FR-2011-09-15/pdf/2011-20740.pdf>.
- U.S. Fish and Wildlife Service. 1996. USFWS Guidelines for Conducting and Reporting Botanical Inventories for Federally Listed, Proposed, and Candidate Plants.

This page is intentionally blank.

9 EIR Preparers and Persons and Organizations Contacted

9.1 EIR Preparers

This EIR was prepared for the County of Imperial by HDR at 591 Camino de la Reina, Suite 300, San Diego, CA 92108. The following professionals participated in its preparation:

County of Imperial

Jim Minnick, Planning & Development Services Director

Michael Abraham, AICP, Assistant Planning & Development Services Director

Diana Robinson, Planning Division Manager

David Black, Planner IV

HDR

Tim Gnibus, Principal

Sharyn Del Rosario, Project Manager

Terrileigh Pellarin, Senior Environmental Planner

Regan Del Rosario, Environmental Planner

Katherine Turner, Document Production Administrator

HDR was assisted by the following consultants:

ECORP Consulting, Inc.

Visual Impact Assessment; Air Quality and Greenhouse Gas Assessment; Biological Technical Report; Aquatic Resources Delineation; Cultural Resources Inventory, Testing and Evaluation Report; Noise Impact Assessment; Energy Impact Assessment

GS Lyon Consultants, Inc.

Phase I Environmental Site Assessment

KOA

Traffic Impact Study

9.2 Persons and Organizations Contacted

The following persons and organizations were contacted in preparation of this document:

- Imperial Irrigation District
- U.S Border Patrol

- Bureau of Reclamation
- Quechan Indian Tribe, Fort Yuma Indian Reservation

Technical Appendices

This page is intentionally blank.

Appendix A

Initial Study and Notice of Preparation and
Responses

Notice of Preparation

To: Office of Planning & Research
(Agency)

P.O. Box 3044, 1400 Tenth Street, Room 212
(Address)

Sacramento, CA 95812-3044

Subject: Notice of Preparation of a Draft Environmental Impact Report

Lead Agency:

Consulting Firm (If applicable):

Agency Name Imperial County, Planning & Dev Svcs.

Firm Name HDR

Street Address 801 Main Street

Street Address 591 Camino de la Reina, Suite 300

City/State/Zip El Centro, CA 92243

City/State/Zip San Diego, CA 92108

Contact Diana Robinson

Contact Tim Gnibus

The County of Imperial will be the Lead Agency and will prepare an Environmental Impact Report (EIR) for the project identified below. We need to know the views of your agency as to the scope and content of the Environmental Information, which is germane to your agency’s statutory responsibilities in connection with the proposed project. Your agency will need to use the EIR prepared by our agency when considering your permit or other approval for the project.

The project description, location, and the potential environmental effects are contained in the attached materials. A copy of the Initial Study is attached.

Due to the time limits mandated by State law, your response must be sent at the earliest possible date but **not later than 35 days** after receipt of this notice.

Please send your response to Imperial County Planning & Development Services, Attn: Diana Robinson at the address shown above. We will need the name for a contact person in your agency.

Project Title: VEGA SES 4 Solar Energy Project


Project Location: The project site is located on approximately 531 acres of privately-owned land in the southernmost portion of Imperial County, California. The project site is between the U.S./Mexico international border and the All-American Canal, on the California side. The project site is proposed on three parcels (Assessor Parcel Numbers 059-290-010, 059-300-015, and 059-300-017) that are contiguous with each other. It is approximately 10 miles east of the City of Calexico in Sections 10, 11, 14, 15, and 16 within Township 17 South, and Range 16 East of the San Bernardino Base and Meridian of the Bonds Corner topographic 7.5 minute quadrangle. As shown on Figure 1, the project site is located entirely within the County’s Renewable Energy Overlay Zone.

Project Description (brief): The proposed project consists of three primary components: 1) solar energy generation equipment and associated facilities including a substation and access roads (herein referred to as “solar energy facility”); 2) battery storage system; and, 3) gen-tie line that would connect the proposed on-site substation to the point of interconnection at the existing Imperial Irrigation District’s (IID) 92-kV “P” line.

The proposed project involves the construction of a 100-megawatt (MW) alternating current (AC) photovoltaic (PV) solar energy facility with an integrated 100 MW battery storage system (not to exceed 200 MW) on approximately 531 acres of land. The project proposes to utilize either thin film or crystalline solar PV technology modules

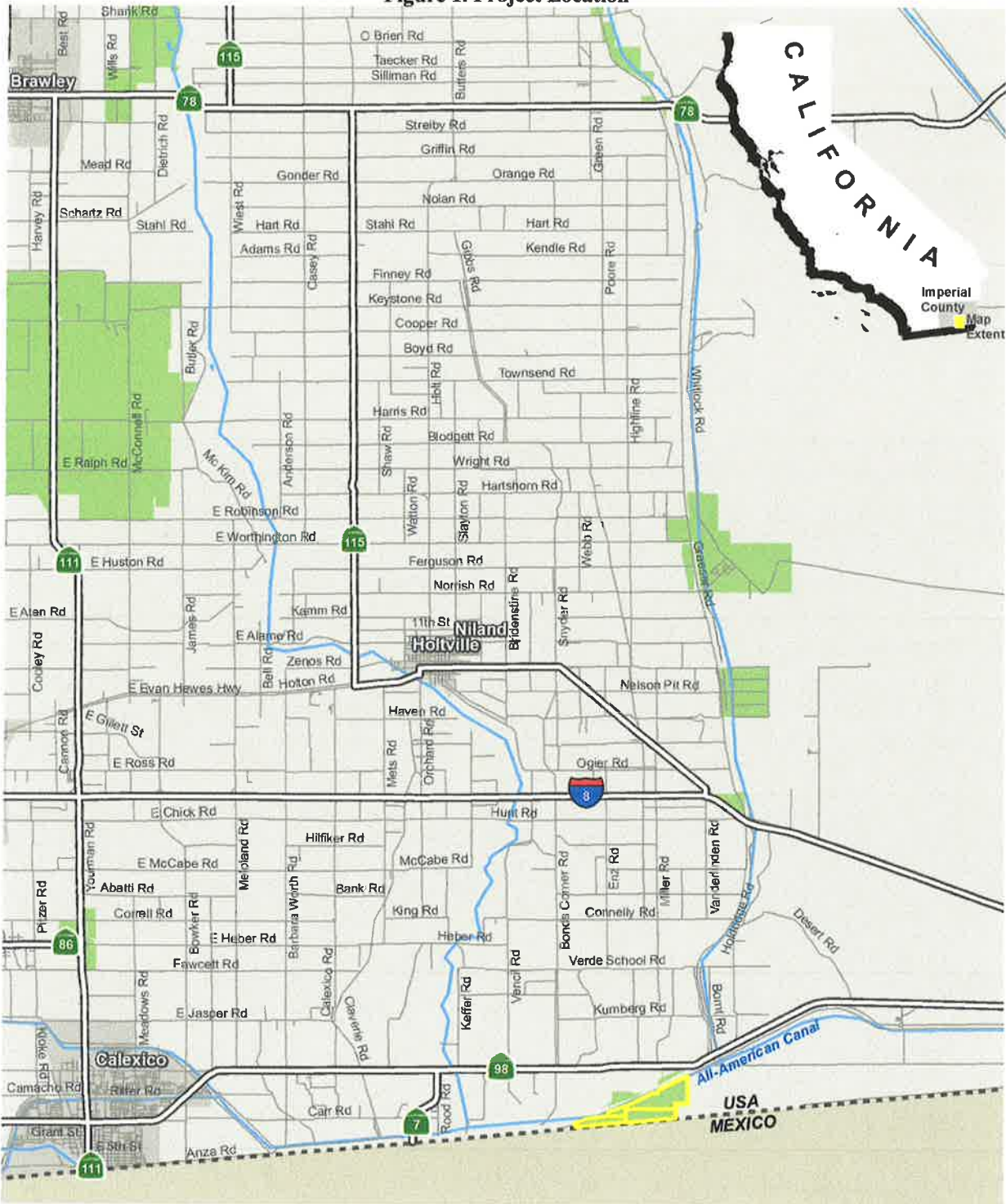
mounted either on fixed frames or horizontal single-axis tracker systems. The project would include electronic/electrical equipment, an on-site substation, access road(s) and fencing. The electrical energy produced by the project would be conducted through the project's interconnection facilities to the proposed 92 kV generator intertie (gen-tie) line and delivered to the existing IID approved point of interconnection on the 92-kV "P" Line.

Project Applicant: Apex Energy Solutions, LLC



Date	<u>April 30, 2021</u>	Signature	<u></u>
		Title	<u>Assistant Director</u>
		Telephone	<u>442-265-1736</u>

Reference: California Administrative Code, Title 14, (CEQA Guidelines) Section 15082(a), 15103, 15375.

Figure 1. Project Location



LEGEND

-  VEGA SES 4 Project Area
-  Renewable Energy Overlay Zone



This page is intentionally blank.

PUBLIC NOTICE

**Imperial County
Planning & Development Services Department**

**NOTICE OF PREPARATION OF DRAFT EIR FOR VEGA SES 4 SOLAR ENERGY PROJECT
AND NOTICE OF PUBLIC EIR SCOPING MEETING**

The Imperial County Planning & Development Services Department intends to prepare an Environmental Impact Report (EIR) for the proposed VEGA SES 4 Solar Energy Project as described below. A public scoping meeting for the proposed EIR will be held by the Imperial County Planning & Development Services Department on **May 13 at 6:00 P.M.** The scoping meeting will be held at the Board of Supervisors Chambers, 2nd Floor, County Administration Center located at 940 Main Street, El Centro, CA 92243. Comments regarding the scope of the EIR will be accepted at this meeting.

SUBJECT: VEGA SES 4 Solar Energy Project EIR

BOARD OF SUPERVISORS CONSIDERATION: To Be Determined.

PROJECT LOCATION: The project site is located on approximately 531 acres of privately-owned land in the southernmost portion of Imperial County, California. The project site is between the U.S./Mexico international border and the All-American Canal, on the California side. The project site is proposed on three parcels (Assessor Parcel Numbers 059-290-010, 059-300-015, and 059-300-017) that are contiguous with each other. It is approximately 10 miles east of the City of Calexico in Sections 10, 11, 14, 15, and 16 within Township 17 South, and Range 16 East of the San Bernardino Base and Meridian of the Bonds Corner topographic 7.5 minute quadrangle. The project site is located entirely within the County's Renewable Energy Overlay Zone.

PROJECT DESCRIPTION: The proposed project consists of three primary components: 1) solar energy generation equipment and associated facilities including a substation and access roads (herein referred to as "solar energy facility"); 2) battery storage system; and, 3) gen tie line that would connect the proposed on site substation to the point of interconnection at the existing Imperial Irrigation District's (IID) 92 kV "P" line.

The proposed project involves the construction of a 100-megawatt (MW) alternating current (AC) photovoltaic (PV) solar energy facility with an integrated 100 MW battery storage system (not to exceed 200 MW) on approximately 531 acres of land. The project proposes to utilize either thin film or crystalline solar PV technology modules mounted either on fixed frames or horizontal single-axis tracker systems. The project would include electronic/electrical equipment, an on-site substation, access road(s) and fencing. The electrical energy produced by the project would be conducted through the project's interconnection facilities to the proposed 92 kV generator intertie (gen-tie) line and delivered to the existing IID approved point of interconnection on the 92-kV "P" Line.

Project Applicant: Apex Energy Solutions, LLC

URBAN AREA PLAN: None, located in unincorporated area of County of Imperial

BOARD OF SUPERVISORS DISTRICT: District 1, Supervisor Jesus E. Escobar

ANTICIPATED SIGNIFICANT EFFECTS: The EIR will analyze potential impacts associated with the following: Aesthetics; Agricultural Resources; Air Quality; Biological Resources; Cultural Resources; Geology/Soils; Greenhouse Gas Emissions/Climate Change; Hazards and Hazardous Materials; Hydrology/Water Quality; Land Use/Planning; Noise; Public Services; Transportation; Tribal Cultural Resources; Utilities and Service Systems including water supply, Cumulative Impacts; and, Growth-Inducing Impacts.

COMMENTS REQUESTED: The Imperial County Planning & Development Services Department would like to know your ideas about the potential effects this project might have on the environment and your suggestions as to mitigation or ways the project may be revised to reduce or avoid any potentially significant environmental impacts. Your comments will guide the scope and content of potential environmental issues to be examined in the EIR. Your comments may be submitted in writing to Diana Robinson, Imperial County Planning & Development Services Department, 801 Main Street, El Centro, CA 92243. Available project information may be reviewed at this location.

NOTICE OF PREPARATION REVIEW PERIOD: May 4, 2021 through June 7, 2021

Legal 9031

Publish: May 6, 2021

Initial Study



Initial Study and NOP

VEGA SES 4 Solar Energy Project

Imperial County, CA

August 2022

Reviewed by:

County of Imperial
Planning & Development
Services Department
801 Main Street
El Centro, CA 92243

Prepared by:

HDR Engineering, Inc.
591 Camino de la Reina,
Suite 300
San Diego, CA 92108

This page is intentionally blank.



Contents

Introduction.....	1
A. Purpose	1
B. CEQA Requirements and the Imperial County’s Rules and Regulations for Implementing CEQA.....	1
C. Intended Uses of Initial Study and Notice of Preparation	2
D. Contents of Initial Study and Notice of Preparation	2
E. Scope of Environmental Analysis.....	3
F. Policy-Level or Project-Level Environmental Analysis	3
G. Tiered Documents and Incorporation by Reference	3
Environmental Checklist Form	1
Environmental Factors Potentially Affected	3
Environmental Evaluation Committee Determination	3
Project Summary.....	5
Project Location.....	5
Project Summary.....	5
Environmental Setting	5
General Plan Consistency.....	5
Evaluation of Environmental Impacts.....	8
I. Aesthetics	10
II. Agriculture and Forestry Resources.....	11
III. Air Quality	13
IV. Biological Resources.....	14
V. Cultural Resources.....	16
VI. Energy	17
VII. Geology and Soils	18
VIII. Greenhouse Gas Emissions	20
IX. Hazards and Hazardous Materials.....	21
X. Hydrology and Water Quality	23
XI. Land Use and Planning.....	25
XII. Mineral Resources	26
XIII. Noise	27
XIV. Population and Housing	28
XV. Public Services.....	29
XVI. Recreation	31
XVII. Transportation	32
XVIII. Tribal Cultural Resources.....	33
XIX. Utilities and Service Systems.....	34
XX. Wildfire	36
XXI. Mandatory Findings of Significance	38
References.....	39
List of Preparers.....	40



This page is intentionally blank.

PC ORIGINAL PKG

Introduction

A. Purpose

This document is a policy-level; project-level Initial Study for evaluation of potential environmental impacts resulting with the proposed VEGA SES 4 Solar Energy Project.

B. CEQA Requirements and the Imperial County's Rules and Regulations for Implementing CEQA

As defined by Section 15063 of the State California Environmental Quality Act (CEQA) Guidelines and Section 7 of the County's Rules and Regulations for Implementing CEQA, an **Initial Study** is prepared primarily to provide the Lead Agency with information to use as the basis for determining whether an Environmental Impact Report (EIR), Negative Declaration, or Mitigated Negative Declaration would be appropriate for providing the necessary environmental documentation and clearance for any proposed project.

- According to Section 15065, an **EIR** is deemed appropriate for a particular proposal if the following conditions occur:
 - The proposal has the potential to substantially degrade quality of the environment.
 - The proposal has the potential to achieve short-term environmental goals to the disadvantage of long-term environmental goals.
 - The proposal has possible environmental effects that are individually limited but cumulatively considerable.
 - The proposal could cause direct or indirect adverse effects on human beings.
- According to Section 15070(a), a **Negative Declaration** is deemed appropriate if the proposal would not result in any significant effect on the environment.
- According to Section 15070(b), a **Mitigated Negative Declaration** is deemed appropriate if it is determined that though a proposal could result in a significant effect, mitigation measures are available to reduce these significant effects to insignificant levels.

This Initial Study has determined that the proposed applications will result in potentially significant environmental impacts and therefore, an Environmental Impact Report is deemed as the appropriate document to provide necessary environmental evaluations and clearance for the proposed project.

This Initial Study and Notice of Preparation are prepared in conformance with the California Environmental Quality Act of 1970, as amended (Public Resources Code, Section 21000 et. seq.); the State CEQA Guidelines & County of Imperial's CEQA Regulations, Guidelines for the Implementation of CEQA; applicable requirements of the County of Imperial; and the regulations, requirements, and procedures of any other responsible public agency or an agency with jurisdiction by law.

Pursuant to the County of Imperial's CEQA Regulations, Guidelines for the Implementation of CEQA, depending on the project scope, the County of Imperial Board of Supervisors, Planning

Commission and/or Planning Director is designated the Lead Agency, in accordance with Section 15050 of the CEQA Guidelines. The Lead Agency is the public agency which has the principal responsibility for approving the necessary environmental clearances and analyses for any project in the County.

C. Intended Uses of Initial Study and Notice of Preparation

This Initial Study and Notice of Preparation are informational documents which are intended to inform County of Imperial decision makers, other responsible or interested agencies, and the general public of potential environmental effects of the proposed applications. The environmental review process has been established to enable public agencies to evaluate environmental consequences and to examine and implement methods of eliminating or reducing any potentially adverse impacts. While CEQA requires that consideration be given to avoiding environmental damage, the Lead Agency and other responsible public agencies must balance adverse environmental effects against other public objectives, including economic and social goals.

The Initial Study and Notice of Preparation, prepared for the project will be circulated for a period of no less than 35 days for public and agency review and comments.

D. Contents of Initial Study and Notice of Preparation

This Initial Study is organized to facilitate a basic understanding of the existing setting and environmental implications of the proposed applications.

SECTION 1

I. INTRODUCTION presents an introduction to the entire report. This section discusses the environmental process, scope of environmental review, and incorporation by reference documents.

SECTION 2

II. ENVIRONMENTAL CHECKLIST FORM contains the County's Environmental Checklist Form. The checklist form presents results of the environmental evaluation for the proposed applications and those issue areas that would have either a significant impact, potentially significant impact, or no impact.

PROJECT SUMMARY, LOCATION AND ENVIRONMENTAL SETTINGS describes the proposed project entitlements and required applications. A description of discretionary approvals and permits required for project implementation is also included. It also identifies the location of the project and a general description of the surrounding environmental settings.

ENVIRONMENTAL ANALYSIS evaluates each response provided in the environmental checklist form. Each response checked in the checklist form is discussed and supported with sufficient data and analysis as necessary. As appropriate, each response discussion describes and identifies specific impacts anticipated with project implementation.

SECTION 3

III. MANDATORY FINDINGS presents Mandatory Findings of Significance in accordance with Section 15065 of the CEQA Guidelines.



E. Scope of Environmental Analysis

For evaluation of environmental impacts, each question from the Environmental Checklist Form is summarized and responses are provided according to the analysis undertaken as part of the Initial Study. Impacts and effects will be evaluated and quantified, when appropriate. To each question, there are four possible responses, including:

1. No Impact: A “No Impact” response is adequately supported if the impact simply does not apply to the proposed applications.
2. Less Than Significant Impact: The proposed applications will have the potential to impact the environment. These impacts, however, will be less than significant; no additional analysis is required.
3. Less Than Significant With Mitigation Incorporated: This applies where incorporation of mitigation measures has reduced an effect from “Potentially Significant Impact” to a “Less Than Significant Impact.”
4. Potentially Significant Impact: The proposed applications could have impacts that are considered significant. Additional analyses and possibly an EIR could be required to identify mitigation measures that could reduce these impacts to less than significant levels.

F. Policy-Level or Project-Level Environmental Analysis

This Initial Study will be conducted under a policy-level, project-level analysis.

Regarding mitigation measures, it is not the intent of this document to “overlap” or restate conditions of approval that are commonly established for future known projects or the proposed applications. Additionally, those other standard requirements and regulations that any development must comply with, that are outside the County’s jurisdiction, are also not considered mitigation measures, and therefore, will not be identified in this document.

G. Tiered Documents and Incorporation by Reference

Information, findings, and conclusions contained in this document are based on incorporation by reference of tiered documentation, which are discussed in the following section.

1. Tiered Documents

As permitted in Section 15152(a) of the CEQA Guidelines, information and discussions from other documents can be included into this document. Tiering is defined as follows:

“Tiering refers to using the analysis of general matters contained in a broader EIR (such as the one prepared for a general plan or policy statement) with later EIRs and negative declarations on narrower projects; incorporating by reference the general discussions from the broader EIR; and concentrating the later EIR or negative declaration solely on the issues specific to the later project.”

Tiering also allows this document to comply with Section 15152(b) of the CEQA Guidelines, which discourages redundant analyses, as follows:

“Agencies are encouraged to tier the environmental analyses which they prepare for separate but related projects including the general plans, zoning changes, and development

projects. This approach can eliminate repetitive discussion of the same issues and focus the later EIR or negative declaration on the actual issues ripe for decision at each level of environmental review. Tiering is appropriate when the sequence of analysis is from an EIR prepared for a general plan, policy or program to an EIR or negative declaration for another plan, policy, or program of lesser scope, or to a site-specific EIR or negative declaration.”

Further, Section 15152(d) of the CEQA Guidelines states:

“Where an EIR has been prepared and certified for a program, plan, policy, or ordinance consistent with the requirements of this section, any lead agency for a later project pursuant to or consistent with the program, plan, policy, or ordinance should limit the EIR or negative declaration on the later project to effects which:

- (1) Were not examined as significant effects on the environment in the prior EIR; or
- (2) Are susceptible to substantial reduction or avoidance by the choice of specific revisions in the project, by the imposition of conditions, or other means.”

2. Incorporation by Reference

Incorporation by reference is a procedure for reducing the size of EIRs/MND and is most appropriate for including long, descriptive, or technical materials that provide general background information, but do not contribute directly to the specific analysis of the project itself. This procedure is particularly useful when an EIR or Negative Declaration relies on a broadly-drafted EIR for its evaluation of cumulative impacts of related projects (*Las Virgenes Homeowners Federation v. County of Los Angeles* [1986, 177 Ca.3d 300]). If an EIR or Negative Declaration relies on information from a supporting study that is available to the public, the EIR or Negative Declaration cannot be deemed unsupported by evidence or analysis (*San Francisco Ecology Center v. City and County of San Francisco* [1975, 48 Ca.3d 584, 595]).

When an EIR or Negative Declaration incorporates a document by reference, the incorporation must comply with Section 15150 of the CEQA Guidelines as follows:

- The incorporated document must be available to the public or be a matter of public record (CEQA Guidelines Section 15150[a]). The General Plan EIR is available, along with this document, at the County of Imperial Planning & Development Services Department, 801 Main Street, El Centro, CA 92243 Ph. (442) 265-1736.
- This document must be available for inspection by the public at an office of the lead agency (CEQA Guidelines Section 15150[b]). These documents are available at the County of Imperial Planning & Development Services Department, 801 Main Street, El Centro, CA 92243, Ph. (442) 265-1736.
- These documents must summarize the portion of the document being incorporated by reference or briefly describe information that cannot be summarized. Furthermore, these documents must describe the relationship between the incorporated information and the analysis in the tiered documents (CEQA Guidelines Section 15150[c]). As discussed above, the tiered EIRs address the entire project site and provide background and inventory information and data which apply to the project site. Incorporated information and/or data will be cited in the appropriate sections.



- These documents must include the State identification number of the incorporated documents (CEQA Guidelines Section 15150[d]). The State Clearinghouse Number for the 'County of Imperial General Plan EIR is SCH #93011023.

The material to be incorporated in this document will include general background information (CEQA Guidelines Section 15150[f])

PC ORIGINAL PKG

Environmental Checklist Form

1. **Project Title:** VEGA SES 4 Solar Energy Project
2. **Lead Agency name and address:** Imperial County Planning & Development Services
Department, 801 Main Street, El Centro, CA 92243
3. **Contact person and phone number:** Diana Robinson, Planner III, 442-265-1751
4. **Project location:** The project site is located on approximately 531 acres of privately-owned land in the southernmost portion of Imperial County, California. The project site is between the U.S./Mexico international border and the All-American Canal, on the California side (Figure 1). As depicted on Figure 2, the project site is on three parcels (Assessor Parcel Numbers 059-290-010, 059-300-015, and 059-300-017) that are contiguous with each other. It is approximately 10 miles east of the City of Calexico in Sections 10, 11, 14, 15, and 16 within Township 17 South, and Range 16 East of the San Bernardino Base and Meridian of the Bonds Corner topographic 7.5 minute quadrangle. As shown on Figure 1, the project site is located entirely within the County's Renewable Energy Overlay Zone.
5. **Project sponsor's name and address:** Apex Energy Solutions, LLC, 604 Sutter Street, Suite 250, Folsom, CA 95630
6. **General Plan Designation:** Agriculture
7. **Zoning:** A-3-RE (Heavy Agriculture with a Renewable Energy Zone Overlay)
8. **Description of project:** The proposed project consists of three primary components: 1) solar energy generation equipment and associated facilities including a substation and access roads (herein referred to as "solar energy facility"); 2) battery storage system; and, 3) gen-tie line that would connect the proposed on-site substation to the point of interconnection at the existing Imperial Irrigation District's 92-kV "P" line.

The proposed project involves the construction of a 100-megawatt (MW) alternating current (AC) photovoltaic (PV) solar energy facility with an integrated 100 MW battery storage system (not to exceed 200 MW) on approximately 531 acres of land. The project proposes to utilize either thin film or crystalline solar PV technology modules mounted either on fixed frames or horizontal single-axis tracker (HSAT) systems. The project would include electronic/electrical equipment, an on-site substation, access road(s) and fencing. The electrical energy produced by the project would be conducted through the project's interconnection facilities to the proposed 92 kV generator intertie (gen-tie) line and delivered to the existing IID approved point of interconnection on the 92-kV "P" Line.
9. **Surrounding land uses and setting: Briefly describe the project's surroundings:** The irregular shaped project site is bound by undeveloped land, portions of which have been disturbed associated with previous agricultural-related activities, to the west and east, the All-American Canal running southwest on the northern border of the project site, and the U.S./Mexico international border to the south. The project site is currently characterized by flat and undeveloped land, portions of which have been disturbed associated with previous agricultural-related activities.

10. Other public agencies whose approval is required (e.g., permits, financing approval, or participation agreement.):

- Department of Public Works – Ministerial permits (building, grading, encroachment)
- Imperial County Air Pollution Control District – Fugitive dust control plan, Authority to construct
- California Regional Water Quality Control Board – Notice of Intent for General Construction Permit
- Imperial Irrigation District – Water supply agreement/permit for water use lease agreement

11. Have California Native American tribes traditionally and culturally affiliated with the project area requested consultation pursuant to Public Resources Code section 21080.3.1? If so, is there a plan for consultation that includes, for example, the determination of significance of impacts to tribal cultural resources, procedures regarding confidentiality, etc.?

12. Yes, an AB 52 consultation request letter was sent to the Quechan Indian Tribe on March 26, 2021. On April 1, 2021, the Quechan Indian Tribe requested consultation with the County on the project.

Environmental Factors Potentially Affected

The environmental factors checked below would be potentially affected by this project, involving at least one impact that is a "Potentially Significant Impact" as indicated by the checklist on the following pages.

- | | | |
|---------------------------------------------------------------|------------------------------------------------------------------------|------------------------------------------------------------------------|
| <input checked="" type="checkbox"/> Aesthetics | <input checked="" type="checkbox"/> Agriculture and Forestry Resources | <input checked="" type="checkbox"/> Air Quality |
| <input checked="" type="checkbox"/> Biological Resources | <input checked="" type="checkbox"/> Cultural Resources | <input type="checkbox"/> Energy |
| <input checked="" type="checkbox"/> Geology/Soils | <input checked="" type="checkbox"/> Greenhouse Gas Emissions | <input type="checkbox"/> Hazards & Hazardous Materials |
| <input checked="" type="checkbox"/> Hydrology / Water Quality | <input type="checkbox"/> Land Use/Planning | <input type="checkbox"/> Mineral Resources |
| <input type="checkbox"/> Noise | <input type="checkbox"/> Population/Housing | <input checked="" type="checkbox"/> Public Services |
| <input type="checkbox"/> Recreation | <input checked="" type="checkbox"/> Transportation | <input checked="" type="checkbox"/> Tribal Cultural Resources |
| <input checked="" type="checkbox"/> Utilities/Service Systems | <input type="checkbox"/> Wildfire | <input checked="" type="checkbox"/> Mandatory Findings of Significance |

Environmental Evaluation Committee Determination

After Review of the Initial Study, the Environmental Evaluation Committee (EEC) has:

- Found that the proposed project COULD NOT have a significant effect on the environment, and a NEGATIVE DECLARATION will be prepared.
- Found that although the proposed project could have a significant effect on the environment, there will not be a significant effect in this case because revisions in the project have been made by or agreed to by the project proponent. A MITIGATED NEGATIVE DECLARATION will be prepared.
- Found that the proposed project MAY have a significant effect on the environment, and an ENVIRONMENTAL IMPACT REPORT is required.
- Found that the proposed project MAY have a "potentially significant impact" or "potentially significant unless mitigated" impact on the environment, but at least one effect 1) has been adequately analyzed in an earlier document pursuant to applicable legal standards, and 2) has been addressed by mitigation measures based on the earlier analysis as described on attached sheets. An ENVIRONMENTAL IMPACT REPORT is required, but it must analyze only the effects that remain to be addressed.
- Found that although the proposed project could have a significant effect on the environment, because all potentially significant effects (a) have been analyzed adequately in an earlier EIR or NEGATIVE DECLARATION pursuant to applicable standards, and (b) have been avoided or mitigated pursuant to that earlier EIR or NEGATIVE DECLARATION, including revisions or mitigation measures that are imposed upon the proposed project, nothing further is required.

CALIFORNIA DEPARTMENT OF FISH AND GAME DE MINIMIS IMPACT FINDING:

Yes No

EEC VOTES

	YES	NO	ABSENT
PUBLIC WORKS	<input type="checkbox"/>	<input type="checkbox"/>	<input type="checkbox"/>
ENVIRONMENTAL HEALTH	<input type="checkbox"/>	<input type="checkbox"/>	<input type="checkbox"/>
OFFICE EMERGENCY SERVICES	<input type="checkbox"/>	<input type="checkbox"/>	<input type="checkbox"/>
APCD	<input type="checkbox"/>	<input type="checkbox"/>	<input type="checkbox"/>
AG	<input type="checkbox"/>	<input type="checkbox"/>	<input type="checkbox"/>
SHERIFF DEPARTMENT	<input type="checkbox"/>	<input type="checkbox"/>	<input type="checkbox"/>
ICPDS	<input type="checkbox"/>	<input type="checkbox"/>	<input type="checkbox"/>

Jim Minnick, Director of Planning/EEC Chairman

Signature

Date:

Project Summary

Project Location

The project site is located on approximately 531 acres of privately-owned land in the southernmost portion of Imperial County, California. The project site is between the U.S./Mexico international border and the All-American Canal, on the California side (Figure 1). As depicted on Figure 2, the project site is on three parcels (Assessor Parcel Numbers 059-290-010, 059-300-015, and 059-300-017) that are contiguous with each other. It is approximately 10 miles east of the City of Calexico in Sections 10, 11, 14, 15, and 16 within Township 17 South, and Range 16 East of the San Bernardino Base and Meridian of the Bonds Corner topographic 7.5 minute quadrangle. As shown on Figure 1, the project site is located entirely within the County’s Renewable Energy Overlay Zone.

Project Summary

The proposed project consists of three primary components: 1) solar energy generation equipment and associated facilities including a substation and access roads (herein referred to as “solar energy facility”); 2) battery storage system; and, 3) gen-tie line that would connect the proposed on-site substation to the point of interconnection at the existing Imperial Irrigation District’s 92-kV “P” line.

The proposed project involves the construction of a 100-megawatt (MW) alternating current (AC) photovoltaic (PV) solar energy facility with an integrated 100 MW battery storage system (not to exceed 200 MW) on approximately 531 acres of land. The project proposes to utilize either thin film or crystalline solar PV technology modules mounted either on fixed frames or horizontal single-axis tracker (HSAT) systems. The project would include electronic/electrical equipment, an on-site substation, access road(s) and fencing. The electrical energy produced by the project would be conducted through the project’s interconnection facilities to the proposed 92 kV generator intertie (gen-tie) line and delivered to the existing IID approved point of interconnection on the 92-kV “P” Line.

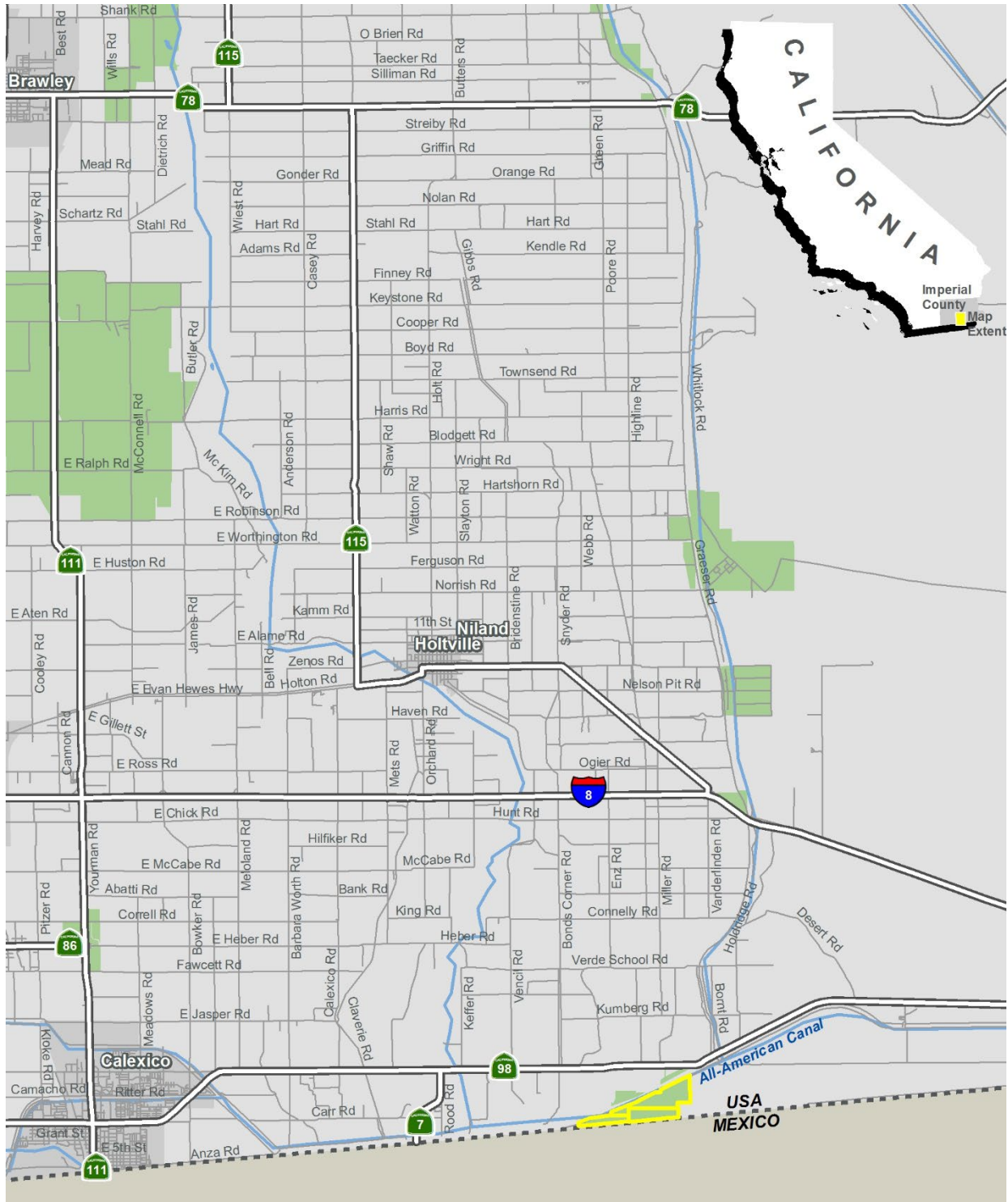
Environmental Setting

The irregular shaped project site is bound by undeveloped land, portions of which have been disturbed associated with previous agricultural-related activities to the west and east, the All-American Canal running southwest on the northern border of the project site, and the U.S./Mexico international border to the south. The project site is currently characterized by flat and undeveloped land, portions of which have been disturbed associated with previous agricultural-related activities.

General Plan Consistency

The proposed project is located within an unincorporated area of the County. The existing General Plan land use designation is “Agriculture.” The project site is currently zoned A-3-RE (Heavy Agriculture with a Renewable Energy Zone Overlay). Construction of a solar facility would be allowed within the existing zoning under a Conditional Use Permit.

Figure 1. Regional Location

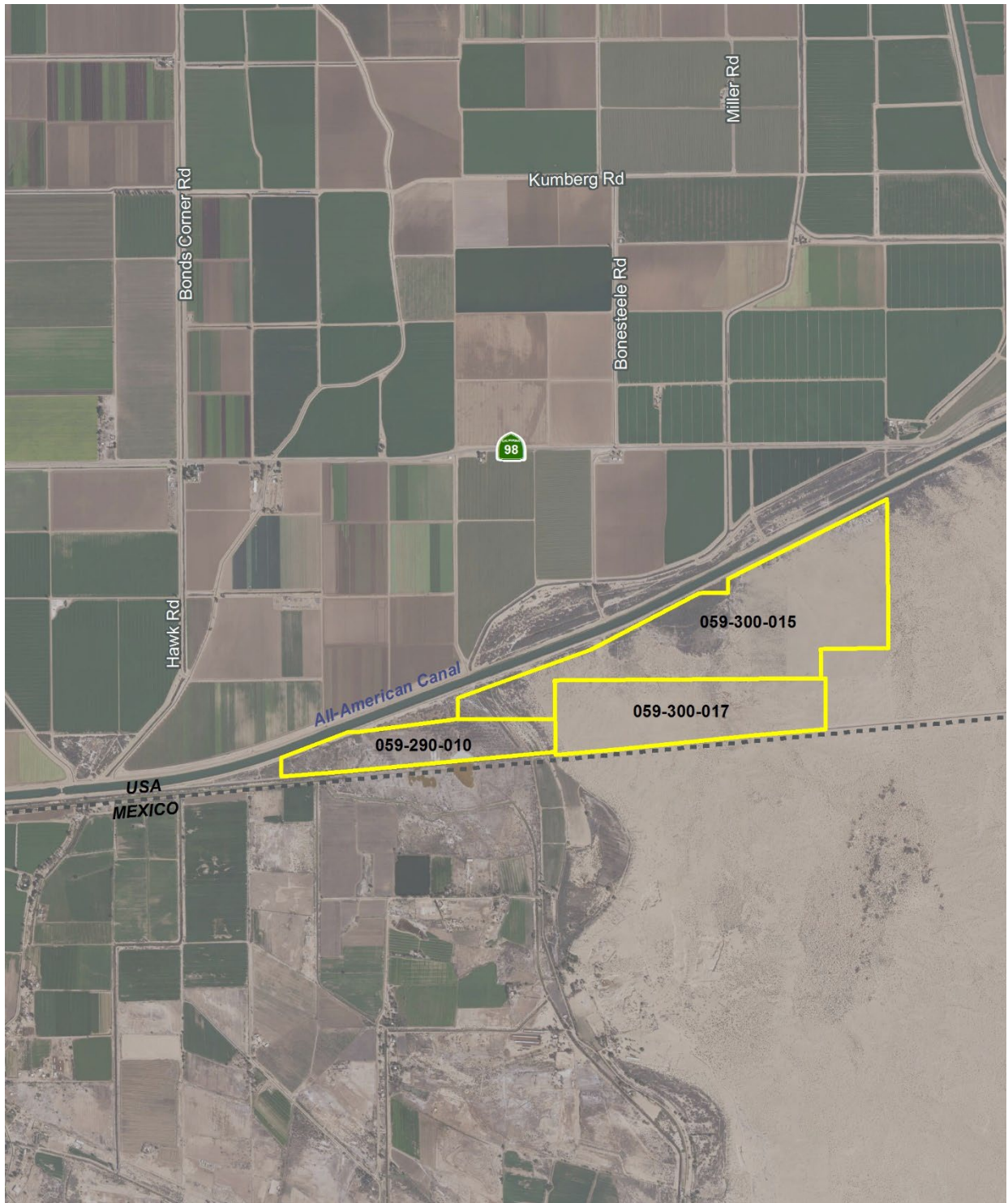


LEGEND

- VEGA SES 4 Project Area
- Renewable Energy Overlay Zone



Figure 2. Project Site



Legend

 VEGA SES 4 Project Parcels



0 Feet 2,000

Evaluation of Environmental Impacts

1. A brief explanation is required for all answers except "No Impact" answers that are adequately supported by the information sources a lead agency cites in the parentheses following each question. A "No Impact" answer is adequately supported if the referenced information sources show that the impact simply does not apply to projects like the one involved (e.g., the project falls outside a fault rupture zone). A "No Impact" answer should be explained where it is based on project-specific factors, as well as general standards (e.g., the project will not expose sensitive receptors to pollutants, based on a project-specific screening analysis).
2. All answers must take account of the whole action involved, including off-site as well as on-site, cumulative as well as project-level, indirect as well as direct, and construction as well as operational impacts.
3. Once the lead agency has determined that a particular physical impact may occur, then the checklist answers must indicate whether the impact is potentially significant, less than significant with mitigation, or less than significant. "Potentially Significant Impact" is appropriate if there is substantial evidence that an effect may be significant. If there are one or more "Potentially Significant Impact" entries when the determination is made, an EIR is required.
4. "Negative Declaration: Less Than Significant With Mitigation Incorporated" applies where the incorporation of mitigation measures has reduced an effect from "Potentially Significant Impact" to a "Less Than Significant Impact." The lead agency must describe the mitigation measures, and briefly explain how they reduce the effect to a less than significant level (mitigation measures from "Earlier Analyses," as described in (5) below, may be cross-referenced).
5. Earlier analyses may be used where, pursuant to the tiering, program EIR, or other CEQA process, an effect has been adequately analyzed in an earlier EIR or negative declaration. Section 15063(c)(3)(D). In this case, a brief discussion should identify the following:
 - a. Earlier Analysis Used. Identify and state where they are available for review.
 - b. Impacts Adequately Addressed. Identify which effects from the above checklist were within the scope of and adequately analyzed in an earlier document pursuant to applicable legal standards, and state whether such effects were addressed by mitigation measures based on the earlier analysis.
 - c. Mitigation Measures. For effects that are "Less than Significant with Mitigation Measures Incorporated," describe the mitigation measures which were incorporated or refined from the earlier document and the extent to which they address site-specific conditions for the project.

6. Lead agencies are encouraged to incorporate into the checklist references to information sources for potential impacts (e.g., general plans, zoning ordinances). Reference to a previously prepared or outside document should, where appropriate, include a reference to the page or pages where the statement is substantiated.
7. Supporting Information Sources: A source list should be attached, and other sources used, or individuals contacted should be cited in the discussion.
8. This is only a suggested form, and lead agencies are free to use different formats; however, lead agencies should normally address the questions from this checklist that are relevant to a project's environmental effects in whatever format is selected.
9. The explanation of each issue should identify:
 - a. The significance criteria or threshold, if any, used to evaluate each question; and
 - b. The mitigation measure identified, if any, to reduce the impact to less than significance.

I. Aesthetics

Environmental Issue Area:	Potentially Significant Impact	Potentially Significant Unless Mitigation Incorporated	Less Than Significant Impact	No Impact
Except as provided in Public Resources Code Section 21099, would the project:				
a) Have a substantial adverse effect on a scenic vista?	<input type="checkbox"/>	<input type="checkbox"/>	<input type="checkbox"/>	<input checked="" type="checkbox"/>
b) Substantially damage scenic resources, including, but not limited to, trees, rock outcroppings, and historic building within a state scenic highway?	<input type="checkbox"/>	<input type="checkbox"/>	<input type="checkbox"/>	<input checked="" type="checkbox"/>
c) In non-urbanized areas, substantially degrade the existing visual character or quality of public views of the site and its surroundings? (Public views are those that are experienced from publicly accessible vantage points). If the project is in an urbanized area, would the project conflict with applicable zoning and other regulations governing scenic quality?	<input checked="" type="checkbox"/>	<input type="checkbox"/>	<input type="checkbox"/>	<input type="checkbox"/>
d) Create a new source of substantial light or glare which would adversely affect day or nighttime views in the area?	<input checked="" type="checkbox"/>	<input type="checkbox"/>	<input type="checkbox"/>	<input type="checkbox"/>

Impact Analysis

- a) **No Impact.** The project site is not located within an area that has been formally identified as a federal, state, or county scenic vista. No scenic vistas or areas with high visual quality would be disrupted. Thus, no impact is identified for this issue area and no further analysis is warranted.
- b) **No Impact.** According to the California Department of Transportation (Caltrans) California Scenic Highway Mapping System (Caltrans 2018), the project site is not located within a state scenic highway corridor, nor are there any state scenic highways located in proximity to the project site. The proposed project would not substantially damage scenic resources, including, but not limited to, trees, rock outcroppings, and historic building within a state scenic highway. Therefore, no impact is identified for this issue area and no further analysis is warranted.
- c) **Potentially Significant Impact.** Although the project site is not located near a scenic highway or designated scenic vista, the proposed project may result in a change to the look and rural character of the area. Therefore, a potentially significant impact is identified for this issue area. A visual assessment will be prepared for the project and this issue will be addressed in the EIR.
- d) **Potentially Significant Impact.** Minimal lighting is required for project operation and is limited to safety and security functions. All lighting will be directed away from any public right-of-way; however, there is no heavily traveled public roadway in immediate proximity to the project site. The solar panels will be constructed of low reflective materials; therefore, it is not anticipated that they would result in creating glare. The proposed project is located in a rural undeveloped area of Imperial County. There are no established residential neighborhoods immediately adjacent to the project site. Although the proposed project is not expected to create a new source of substantial light or glare affecting day or nighttime views, this issue will be analyzed further in the EIR. Therefore, a potentially significant impact is identified for this issue area.

II. Agriculture and Forestry Resources

Environmental Issue Area:	Potentially Significant Impact	Potentially Significant Unless Mitigation Incorporated	Less Than Significant Impact	No Impact
<p><i>In determining whether impacts to agricultural resources are significant environmental effects, lead agencies may refer to the California Agricultural Land Evaluation and Site Assessment Model (1997) prepared by the California Department of Conservation as an optional model to use in assessing impacts on agriculture and farmland. In determining whether impacts to forest resources, including timberland, are significant environmental effects, lead agencies may refer to information compiled by the California Department of Forestry and Fire Protection regarding the state's inventory of forest land, including the Forest and Range Assessment Project and the Forest Legacy Assessment project; and forest carbon measurement methodology provided in Forest Protocols adopted by the California Air Resources Board.</i></p> <p>Would the project:</p>				
<p>a) Convert Prime Farmland, Unique Farmland, or Farmland of Statewide Importance (Farmland), as shown on the maps prepared pursuant to the Farmland Mapping and Monitoring Program of the California Resources Agency, to non-agricultural use?</p>	<input type="checkbox"/>	<input type="checkbox"/>	<input type="checkbox"/>	<input checked="" type="checkbox"/>
<p>b) Conflict with existing zoning for agricultural use, or a Williamson Act contract?</p>	<input checked="" type="checkbox"/>	<input type="checkbox"/>	<input type="checkbox"/>	<input type="checkbox"/>
<p>c) Conflict with existing zoning for, or cause rezoning of, forest land (as defined in Public Resources Code section 12220(g)), timberland (as defined by Public Resources Code section 4526), or timberland zoned Timberland Production (as defined by Government Code section 51104(g))?</p>	<input type="checkbox"/>	<input type="checkbox"/>	<input type="checkbox"/>	<input checked="" type="checkbox"/>
<p>d) Result in the loss of forest land or conversion of forest land to non-forest use?</p>	<input type="checkbox"/>	<input type="checkbox"/>	<input type="checkbox"/>	<input checked="" type="checkbox"/>
<p>e) Involve other changes in the existing environment which, due to their location or nature, could result in conversion of Farmland, to non-agricultural use or conversion of forest land to non-forest use?</p>	<input type="checkbox"/>	<input type="checkbox"/>	<input type="checkbox"/>	<input checked="" type="checkbox"/>

Impact Analysis

- a) **No Impact.** According to the farmland maps prepared by the California Department of Conservation (2016), the majority of the project site is designated as Other Land. A portion of the project site is designated as Farmland of Local Importance. Farmland of Local Importance is not considered an “agricultural land” per CEQA Statute Section 21060.1(a). Furthermore, the project site does not contain Prime Farmland, Farmland of Statewide Importance, or Unique Farmland. Therefore, no impact would result from the conversion of Prime Farmland, Farmland of Statewide Importance, or Unique Farmland to non-agricultural use.

- b) **Potentially Significant Impact.** The project site is currently designated by the General Plan as “Agriculture” and is zoned A-3-RE (Heavy Agriculture with a Renewable Energy Zone Overlay). Pursuant to Title 9, Division 5, Chapter 9, “Solar Energy Plants” and “Transmission lines, including supporting towers, poles microwave towers, utility substations” are uses that are permitted in the A-3 Zone, subject to approval of a CUP. Because the project site is located on lands designated for agricultural uses, this issue will be analyzed in further detail in the EIR.

According to the 2016/2017 Imperial County Williamson Act Map produced by the California Department of Conservation’s Division of Land Resource Protection, the project site is not located on Williamson Act contracted land. Therefore, the proposed project would not conflict with a Williamson Act contract and no impact would occur.

- c) **No Impact.** There are no existing forest lands, timberlands, or timberland zoned “Timberland Production” within or immediately adjacent to the project site that would conflict with existing zoning or cause rezoning. Therefore, no impact is identified for this issue area.
- d) **No Impact.** There are no existing forest lands within or immediately adjacent to the project site. The proposed project would not result in the loss of forest land or conversion of forest land to non-forest use. Therefore, no impact is identified for this issue area.
- e) **No Impact.** Refer to response II. a) above.

III. Air Quality

Environmental Issue Area:	Potentially Significant Impact	Potentially Significant Unless Mitigation Incorporated	Less Than Significant Impact	No Impact
<i>Where available, the significance criteria established by the applicable air quality management district or air pollution control district may be relied upon to make the following determinations.</i>				
<i>Would the project:</i>				
a) Conflict with or obstruct implementation of the applicable air quality plan?	<input checked="" type="checkbox"/>	<input type="checkbox"/>	<input type="checkbox"/>	<input type="checkbox"/>
b) Result in a cumulatively considerable net increase of any criteria pollutant for which the project region is non-attainment under an applicable federal or state ambient air quality standard?	<input checked="" type="checkbox"/>	<input type="checkbox"/>	<input type="checkbox"/>	<input type="checkbox"/>
c) Expose sensitive receptors to substantial pollutant concentrations?	<input checked="" type="checkbox"/>	<input type="checkbox"/>	<input type="checkbox"/>	<input type="checkbox"/>
d) Result in other emissions (such as those leading to odors adversely affecting a substantial number of people)?	<input type="checkbox"/>	<input type="checkbox"/>	<input type="checkbox"/>	<input checked="" type="checkbox"/>

Impact Analysis

- a) **Potentially Significant Impact.** The project site is located within the jurisdiction of Imperial County Air Pollution Control District (ICAPCD) in the Imperial County portion of the Salton Sea Air Basin. Construction of the proposed project would create temporary emissions of dust, fumes, equipment exhaust, and other air contaminants that may conflict with the ICAPCD’s rules and regulations. No stationary source emissions are proposed from the proposed project; however, temporary construction emissions have the potential to result in a significant air quality impact.
- b) **Potentially Significant Impact.** Currently, the Salton Sea Air Basin is either in attainment or unclassified for all federal and state air pollutant standards, with the exception of the federal ozone (O₃), particulate matter less than 10 microns in diameter (PM₁₀) and particulate matter less than 2.5 microns in diameter (PM_{2.5}) standards, and state standards for O₃ and PM₁₀. Air pollutants transported into the Salton Sea Air Basin from the adjacent South Coast Air Basin (Los Angeles County, San Bernardino County, Orange County, and Riverside County) and Mexicali (Mexico) substantially contribute to the non-attainment conditions in the Salton Sea Air Basin. A potentially significant impact is identified for this issue area. An air quality and greenhouse gas study will be prepared to analyze the proposed project’s potential air quality impacts and will be included in the EIR analysis.
- c) **Potentially Significant Impact.** The project site is located in a rural agricultural area of Imperial County. Sensitive receptors consisting of a few scattered rural homes along SR-98 are located within one mile north of the project site. This issue will be addressed in the air quality and greenhouse gas study and EIR analysis.
- d) **No Impact.** Land uses commonly considered to be potential sources of odorous emissions include wastewater treatment plants, sanitary landfills, food processing facilities, chemical manufacturing plants, rendering plants, paint/coating operations, and concentrated agricultural feeding operations and dairies. The construction and operation of a solar facility is not an odor producer and the project site is not located near an odor producer. Therefore, no impact is identified for this issue area.

IV. Biological Resources

Environmental Issue Area:	Potentially Significant Impact	Potentially Significant Unless Mitigation Incorporated	Less Than Significant Impact	No Impact
Would the project:				
a) Have a substantial adverse effect, either directly or through habitat modifications, on any species identified as a candidate, sensitive, or special status species in local or regional plans, policies, or regulations, or by the California Department of Fish and Game or U.S. Fish and Wildlife Service?	<input checked="" type="checkbox"/>	<input type="checkbox"/>	<input type="checkbox"/>	<input type="checkbox"/>
b) Have a substantial adverse effect on any riparian habitat or other sensitive natural community identified in local or regional plans, policies, and regulations or by the California Department of Fish and Game or U.S. Fish and Wildlife Service?	<input checked="" type="checkbox"/>	<input type="checkbox"/>	<input type="checkbox"/>	<input type="checkbox"/>
c) Have a substantial adverse effect on state or federally protected wetlands (including, but not limited to, marsh, vernal pool, coastal, etc.) through direct removal, filling, hydrological interruption, or other means?	<input checked="" type="checkbox"/>	<input type="checkbox"/>	<input type="checkbox"/>	<input type="checkbox"/>
d) Interfere substantially with the movement of any native resident or migratory fish or wildlife species or with established native resident or migratory wildlife corridors, or impede the use of wildlife nursery sites?	<input checked="" type="checkbox"/>	<input type="checkbox"/>	<input type="checkbox"/>	<input type="checkbox"/>
e) Conflict with any local policies or ordinances protecting biological resources, such as a tree preservation policy or ordinance?	<input checked="" type="checkbox"/>	<input type="checkbox"/>	<input type="checkbox"/>	<input type="checkbox"/>
f) Conflict with the provisions of an adopted Habitat Conservation Plan, Natural Community Conservation Plan, or other approved local, regional, or state habitat conservation plan?	<input type="checkbox"/>	<input type="checkbox"/>	<input type="checkbox"/>	<input checked="" type="checkbox"/>

Impact Analysis

- a) **Potentially Significant Impact.** According to the Conservation and Open Space Element of the General Plan (County of Imperial 2016), numerous special-status species occur in the County of Imperial, and of particular concern are the western burrowing owl and flat-tailed horned lizard which may have the potential to occur within the project site. The project site has the potential to support native habitats and/or sensitive species. Burrowing owls and burrows are commonly found along canals and drains. Although there are no IID canals located within the project site, access roads, canals, and other drainages are located in the project vicinity, such as the All American Canal immediately north of the proposed project. Thus, a potentially

significant impact is identified for this issue area. A biological resources technical study that will address the proposed project's potential impacts on biological resources will be prepared and included in the EIR analysis.

- b) **Potentially Significant Impact.** Refer to response IV. a) above.
- c) **Potentially Significant Impact.** According to the National Wetlands Inventory, there are two wetland features mapped within the project site. An aquatic resources delineation that will address the proposed project's potential impacts on state or federally protected wetlands will be prepared and included in the EIR analysis.
- d) **Potentially Significant Impact.** Refer to response IV. a) above.
- e) **Potentially Significant Impact.** Refer to response IV. a) above.
- f) **No Impact.** The project site is not located in a Habitat Conservation Plan, Natural Community Conservation Plan, or other approved local, regional, or state habitat conservation plan. No impact is identified for this issue area.

V. Cultural Resources

Environmental Issue Area:	Potentially Significant Impact	Potentially Significant Unless Mitigation Incorporated	Less Than Significant Impact	No Impact
Would the project:				
a) Cause a substantial adverse change in the significance of a historical resource pursuant to §15064.5?	<input checked="" type="checkbox"/>	<input type="checkbox"/>	<input type="checkbox"/>	<input type="checkbox"/>
b) Cause a substantial adverse change in the significance of an archaeological resource pursuant to §15064.5?	<input checked="" type="checkbox"/>	<input type="checkbox"/>	<input type="checkbox"/>	<input type="checkbox"/>
c) Disturb any human remains, including those interred outside of dedicated cemeteries?	<input checked="" type="checkbox"/>	<input type="checkbox"/>	<input type="checkbox"/>	<input type="checkbox"/>

Impact Analysis

- a) **Potentially Significant Impact.** The project site consists of undeveloped land that appears to have been historically altered. The disturbed nature of the site, including the existence of old agricultural-use related foundations and farming equipment including an irrigation system, indicates that portions of the land may have been historically used for agricultural purposes. Thus, the presence of significant or undamaged cultural resources on the site is unlikely. Although the proposed project is not expected to cause a substantial adverse change in the significance of a historical resource or archaeological resource, this issue will be analyzed further in the EIR. Therefore, a potentially significant impact is identified for this issue area. A cultural resources report that will address the proposed project's potential impacts on historic and prehistoric resources will be prepared and this issue will be addressed in the EIR.
- b) **Potentially Significant Impact.** Refer to response V. a) above.
- c) **Potentially Significant Impact.** Although unlikely, there is a potential for unknown human remains to be unearthed during earthwork activities. This issue is potentially significant and will be addressed in the EIR.

VI. Energy

Environmental Issue Area:	Potentially Significant Impact	Potentially Significant Unless Mitigation Incorporated	Less Than Significant Impact	No Impact
Would the project:				
a) Result in potentially significant environmental impact due to wasteful, inefficient, or unnecessary consumption of energy resources, during project construction or operation?	<input type="checkbox"/>	<input type="checkbox"/>	<input checked="" type="checkbox"/>	<input type="checkbox"/>
b) Conflict with or obstruct a state or local plan for renewable energy or energy efficiency?	<input type="checkbox"/>	<input type="checkbox"/>	<input type="checkbox"/>	<input checked="" type="checkbox"/>

Impact Analysis

- a) **Less than Significant Impact.** The use of energy associated with the proposed project includes both construction and operational activities. Construction activities consume energy through the use of heavy construction equipment and truck and worker traffic. The proposed project will use energy-conserving construction equipment, including standards for construction combustion equipment recommended in the ICAPCD CEQA Air Quality Handbook. The use of better engine technology, in conjunction with the ICAPCD's standards will reduce the amount of energy used for the proposed project. Additionally, implementation and operation of the proposed project would promote the use of renewable energy and contribute incrementally to the reduction in demand for fossil fuel use for electricity-generating purposes. Therefore, the proposed project would generate renewable energy resources and is considered a beneficial effect.

Based on these considerations, the proposed project would not result in significant environmental impacts due to wasteful, inefficient, or unnecessary consumption of energy resources during construction or operation. A less than significant impact has been identified for this issue area.

- b) **No Impact.** The proposed project would help California meet its Renewable Portfolio Standard of 60 percent of retail electricity sales from renewable sources by the end of 2030 and 100 percent by 2045. The electricity generation process associated with the project would utilize solar technology to convert sunlight directly into electricity. Solar PV technology is consistent with the definition of an "eligible renewable energy resource" in Section 399.12 of the California Public Utilities Code (CPUC) and the definition of "in-state renewable electricity generation facility" in Section 25741 of the CPUC. Therefore, the proposed project would not conflict with or obstruct a state or local plan for renewable energy or energy efficiency. No Impact is identified for this issue area and no further analysis is warranted.

VII. Geology and Soils

Environmental Issue Area:	Potentially Significant Impact	Potentially Significant Unless Mitigation Incorporated	Less Than Significant Impact	No Impact
Would the project:				
a) Directly or indirectly cause potential substantial adverse effects, including the risk of loss, injury or death involving:				
i. Rupture of a known earthquake fault, as delineated on the most recent Alquist-Priolo Earthquake Fault Zoning Map issued by the State Geologist for the area or based on other substantial evidence of a known fault? Refer to Division of Mines and Geology Special Publication 42?	<input type="checkbox"/>	<input type="checkbox"/>	<input type="checkbox"/>	<input checked="" type="checkbox"/>
ii. Strong seismic ground shaking?	<input checked="" type="checkbox"/>	<input type="checkbox"/>	<input type="checkbox"/>	<input type="checkbox"/>
iii. Seismic-related ground failure, including liquefaction?	<input checked="" type="checkbox"/>	<input type="checkbox"/>	<input type="checkbox"/>	<input type="checkbox"/>
iv. Landslides?	<input type="checkbox"/>	<input type="checkbox"/>	<input type="checkbox"/>	<input checked="" type="checkbox"/>
b) Result in substantial soil erosion or the loss of topsoil?	<input type="checkbox"/>	<input type="checkbox"/>	<input checked="" type="checkbox"/>	<input type="checkbox"/>
c) Be located on a geologic unit or soil that is unstable, or that would become unstable as a result of the project and potentially result in on- or off-site landslide, lateral spreading, subsidence, liquefaction, or collapse?	<input checked="" type="checkbox"/>	<input type="checkbox"/>	<input type="checkbox"/>	<input type="checkbox"/>
d) Be located on expansive soil, as defined in Table 18-1B of the Uniform Building Code (1994), creating substantial direct or indirect risk to life or property?	<input checked="" type="checkbox"/>	<input type="checkbox"/>	<input type="checkbox"/>	<input type="checkbox"/>
e) Have soils incapable of adequately supporting the use of septic tanks or alternative wastewater disposal systems where sewers are not available for the disposal of wastewater?	<input type="checkbox"/>	<input type="checkbox"/>	<input type="checkbox"/>	<input checked="" type="checkbox"/>
f) Directly or indirectly destroy a unique paleontological resource or site or unique geologic feature?	<input checked="" type="checkbox"/>	<input type="checkbox"/>	<input type="checkbox"/>	<input type="checkbox"/>

Impact Analysis

- ai) **No Impact.** The project site is not located within a State of California, Alquist-Priolo Earthquake Fault Zone. Therefore, no impact is identified for this issue area.
- a ii) **Potentially Significant Impact.** The project site is located in the seismically-active Imperial Valley in Southern California and considered likely to be subjected to moderate to strong ground motion from earthquakes in the region. The project site could be affected by the occurrence of seismic activity to some degree but no more than the surrounding properties. A potentially significant impact has been identified for this issue area. A geotechnical report that will address the proposed project's potential impacts on geology and soils will be prepared and this issue will be addressed in the EIR.
- a iii) **Potentially Significant Impact.** Liquefaction occurs when granular soil below the water table is subjected to vibratory motions, such as vibratory motion produced by earthquakes. With strong ground shaking, an increase in pore water pressure develops as the soil tends to reduce in volume. If the increase in pore water pressure is sufficient to reduce the vertical effective stress (suspending the soil particles in water), the soil strength decreases, and the soil behaves as a liquid (similar to quicksand). Liquefaction can produce excessive settlement, ground rupture, lateral spreading, or failure of shallow bearing foundations.

Four conditions are generally required for liquefaction to occur:

- 1) The soil must be saturated (relatively shallow groundwater).
- 2) The soil must be loosely packed (low to medium relative density).
- 3) The soil must be relatively cohesionless (not clayey).
- 4) Groundshaking of sufficient intensity must occur to function as a trigger mechanism.

All these conditions may exist to some degree at the project site. Therefore, there is a potentially significant impact associated with liquefaction. A geotechnical report that will address the proposed project's potential impacts on geology and soils will be prepared and this issue will be addressed in the EIR.

- a iv) **No Impact.** According to Figure 2: Landslide Activity in the Seismic and Public Safety Element of the General Plan (County of Imperial 1997), the project site is not located in an area that is prone to landslide hazards. Furthermore, the project site and surrounding area is relatively flat. Therefore, no impact is identified for this issue area.
- b) **Less than Significant Impact.** According to Figure 3: Erosion Activity in the Soil the Seismic and Public Safety Element of the General Plan (County of Imperial 1997), the project site is within a generally flat area with low levels of natural erosion. However, soil erosion can result during construction as grading and construction can loosen surface soils and make soils susceptible to wind and water movement across the surface. Impacts are not considered significant because erosion would be controlled on-site in accordance with Imperial County standards including preparation, review, and approval of a grading plan by the Imperial County Engineer. Implementation of Imperial County standards would reduce the potential impacts to a less than significant level.
- c) **Potentially Significant Impact.** Near surface soils within the project site will need to be identified to determine if the soils are unstable. Therefore, this issue is potentially significant and will be analyzed in the EIR.
- d) **Potentially Significant Impact.** Near surface soils within the project site will need to be identified to determine if they consist of soils having expansion potential. Therefore, this issue is potentially significant and will be analyzed in the EIR.
- e) **No Impact.** The proposed project would not require the installation of septic tanks or alternative wastewater disposal systems. The proposed solar facility would be remotely operated, controlled and monitored and with no requirement for daily on-site employees. Therefore, no impact is identified for this issue area.
- f) **Potentially Significant Impact.** Many paleontological fossil sites are recorded in Imperial County and have been discovered during construction activities. Paleontological resources are typically impacted when earthwork activities, such as mass excavation cut into geological deposits (formations) with buried fossils. It is not known if any paleontological resources are located on the project site. The proposed project's potential to impact paleontological resources will be addressed in the EIR.

VIII. Greenhouse Gas Emissions

Environmental Issue Area:	Potentially Significant Impact	Potentially Significant Unless Mitigation Incorporated	Less Than Significant Impact	No Impact
Would the project:				
a) Generate greenhouse gas emissions, either directly or indirectly, that may have a significant impact on the environment?	<input checked="" type="checkbox"/>	<input type="checkbox"/>	<input type="checkbox"/>	<input type="checkbox"/>
b) Conflict with an applicable plan, policy, or regulation adopted for the purpose of reducing the emissions of greenhouse gases?	<input checked="" type="checkbox"/>	<input type="checkbox"/>	<input type="checkbox"/>	<input type="checkbox"/>

Impact Analysis

- a) **Potentially Significant Impact.** In the long-term, the project is expected to provide a benefit with respect to reduction of greenhouse gas emissions. However, the proposed project has the potential to generate greenhouse gas emissions during construction, in addition to construction worker trips to and from the project site. Thus, a potentially significant impact is identified for this issue area. A greenhouse gas emissions/climate change technical report will be prepared for the proposed project, and this issue will be addressed in the EIR.
- b) **Potentially Significant Impact.** Refer to response VIII. a) above.

IX. Hazards and Hazardous Materials

Environmental Issue Area:	Potentially Significant Impact	Potentially Significant Unless Mitigation Incorporated	Less Than Significant Impact	No Impact
Would the project:				
a) Create a significant hazard to the public or the environment through the routine transport, use, or disposal of hazardous materials?	<input type="checkbox"/>	<input type="checkbox"/>	<input checked="" type="checkbox"/>	<input type="checkbox"/>
b) Create a significant hazard to the public or the environment through reasonably foreseeable upset and accident conditions involving the likely release of hazardous materials into the environment?	<input type="checkbox"/>	<input type="checkbox"/>	<input checked="" type="checkbox"/>	<input type="checkbox"/>
c) Emit hazardous emissions or handle hazardous or acutely hazardous materials, substances, or waste within one-quarter mile of an existing or proposed school?	<input type="checkbox"/>	<input type="checkbox"/>	<input type="checkbox"/>	<input checked="" type="checkbox"/>
d) Be located on a site which is included on a list of hazardous materials sites compiled pursuant to Government Code Section 65962.5 and, as a result, would it create a significant hazard to the public or the environment?	<input type="checkbox"/>	<input type="checkbox"/>	<input type="checkbox"/>	<input checked="" type="checkbox"/>
e) For a project located within an airport land use plan or, where such a plan has not been adopted, within two miles of a public airport or public use airport, would the project result in a safety hazard or excessive noise for people residing or working in the project area?	<input type="checkbox"/>	<input type="checkbox"/>	<input type="checkbox"/>	<input checked="" type="checkbox"/>
f) Impair implementation of or physically interfere with an adopted emergency response plan or emergency evacuation plan?	<input type="checkbox"/>	<input type="checkbox"/>	<input checked="" type="checkbox"/>	<input type="checkbox"/>
g) Expose people or structures, either directly or indirectly, to a significant risk of loss, injury, or death involving wildland fires?	<input type="checkbox"/>	<input type="checkbox"/>	<input checked="" type="checkbox"/>	<input type="checkbox"/>

Impact Analysis

- a) **Less than Significant Impact.** Construction of the proposed project will involve the limited use of hazardous materials, such as fuels and greases to fuel and service construction equipment. No extremely hazardous substances are anticipated to be produced, used, stored, transported, or disposed of as a result of project construction. Operation of the project will be conducted remotely. Therefore, no habitable structures (e.g. housing or operation and maintenance [O&M] building) are proposed on-site. Regular and routine maintenance of the proposed project may result in the potential to handle hazardous materials. However, the hazardous materials handled on-site would be limited to small amounts of everyday use cleaners and common chemicals used for maintenance. The applicant will be required to comply with State

laws and County Ordinance restrictions, which regulate and control hazardous materials handled on-site. Such hazardous wastes would be transported off-site for disposal according to applicable State and County restrictions and laws governing the disposal of hazardous waste during construction and operation of the project. Therefore, this is considered a less than significant impact.

- b) **Less than Significant Impact.** Refer to response IX. a) above.
- c) **No Impact.** The project site is not located within 0.25 mile of an existing or proposed school. No impact is identified for this issue area.
- d) **No Impact.** Based on a review of the Cortese List conducted in March 2021, the project site is not listed as a hazardous materials site. No impact is identified for this issue area.
- e) **No Impact.** The project site is not located within 2 miles of a public airport. The nearest airports to the project site are the Calexico International Airport located approximately 10 miles west of the project site and Holtville Airport located approximately 10 miles north of the project site. Therefore, implementation of the proposed project would not result in a safety hazard or excessive noise for people residing or working in the project area. No impact is identified for this issue area.
- f) **Less than Significant Impact.** The proposed project is not expected to impair implementation of or physically interfere with an adopted emergency response plan or emergency evacuation plan. The project applicant will be required, through the conditions of approval, to prepare a street improvement plan for the project that will include emergency access points and safe vehicular travel. In addition, local building codes would be followed to minimize flood, seismic, and fire hazard. Therefore, the proposed project would result in a less than significant impact associated with the possible impediment to emergency plans.
- g) **Less than Significant Impact.** The project site is located in the unincorporated area of Imperial County. According to the Seismic and Public Safety Element of the General Plan (County of Imperial 1997), the potential for a major fire in the unincorporated areas of the County is generally low. A 10,000-gallon aboveground water storage tank will be installed on-site as required by the Imperial County Fire Department. The water tank(s) would be sized to meet the requirements of the County of Imperial to supply sufficient fire suppression water during operations. Furthermore, proposed project facilities would be designed, constructed, and operated in accordance with applicable fire protection and other environmental, health, and safety requirements. Based on these considerations, a less than significant impact is identified for this issue area.

X. Hydrology and Water Quality

Environmental Issue Area:	Potentially Significant Impact	Potentially Significant Unless Mitigation Incorporated	Less Than Significant Impact	No Impact
Would the project:				
a) Violate any water quality standards or waste discharge requirements or otherwise substantially degrade surface or ground water quality?	<input checked="" type="checkbox"/>	<input type="checkbox"/>	<input type="checkbox"/>	<input type="checkbox"/>
b) Substantially decrease groundwater supplies or interfere substantially with groundwater recharge such that the project may impede sustainable groundwater management of the basin?	<input type="checkbox"/>	<input type="checkbox"/>	<input checked="" type="checkbox"/>	<input type="checkbox"/>
c) Substantially alter the existing drainage pattern of the site or area, including through the alteration of the course of a stream or river or through the addition of impervious surfaces, in a manner which would:				
i. result in substantial erosion or siltation on- or off-site;	<input type="checkbox"/>	<input type="checkbox"/>	<input checked="" type="checkbox"/>	<input type="checkbox"/>
ii. substantially increase the rate or amount of surface runoff in a manner which would result in flooding on- or offsite;	<input type="checkbox"/>	<input type="checkbox"/>	<input checked="" type="checkbox"/>	<input type="checkbox"/>
iii. create or contribute runoff water which would exceed the capacity of existing or planned stormwater drainage systems or provide substantial additional sources of polluted runoff; or	<input type="checkbox"/>	<input type="checkbox"/>	<input checked="" type="checkbox"/>	<input type="checkbox"/>
iv. impede or redirect flood flows?	<input type="checkbox"/>	<input type="checkbox"/>	<input type="checkbox"/>	<input checked="" type="checkbox"/>
d) In flood hazard, tsunami, or seiche zones, risk release of pollutants due to project inundation?	<input type="checkbox"/>	<input type="checkbox"/>	<input type="checkbox"/>	<input checked="" type="checkbox"/>
e) Conflict with or obstruct implementation of a water quality control plan or sustainable groundwater management plan?	<input type="checkbox"/>	<input type="checkbox"/>	<input type="checkbox"/>	<input checked="" type="checkbox"/>

Impact Analysis

- a) **Potentially Significant Impact.** The proposed project has the potential to create urban non-point source discharge (e.g., synthetic/organic chemicals). Potentially significant water quality impacts have been identified and will be addressed in the EIR.
- b) **Less than Significant Impact.** During construction, potable water would be brought to the site for drinking and domestic needs, while construction water would be brought to the project site for soil conditioning and

dust suppression. During operations, potable water would be trucked onto the project site. Because the solar panels will be pole-mounted above ground, they are not considered “hardscape”, such as roads, building foundations, or parking areas, as they do not require a substantial amount of impervious material. The panels and their mounting foundation would not impede groundwater recharge. Therefore, impacts would be less than significant.

- ci) **Less than Significant Impact.** The proposed project would not substantially alter the existing drainage pattern of the site. It is anticipated that the proposed drainage patterns would be similar to the existing site conditions. The project applicant would be required to implement on-site erosion control measures in accordance with Imperial County standards including preparation, review, and approval of a grading plan by the Imperial County Engineer. The proposed project is not anticipated to generate a significant increase in the amount of runoff water from water use involving solar panel washing. Water will continue to percolate through the ground, as a majority of the surface on the project site will remain pervious. Therefore, the proposed project would not substantially increase the rate of runoff, in a manner which would exceed the capacity of existing or planned stormwater drainage systems and result in flooding on- or off-site. A less than significant impact is identified for this issue area.
- cii) **Less than Significant Impact.** Refer to response X. ci) above.
- ciii) **Less than Significant Impact.** Refer to response X. ci) above.
- civ) **No Impact.** According to the Federal Emergency Management Agency (FEMA) Flood Insurance Rate Map (Panel 06025C2125C) (FEMA 2008), the project site is within Zone X, which is an area determined to be outside of the 0.2 percent annual chance of a flood. The proposed project does not propose the placement of structures within a 100-year flood hazard area. Therefore, the proposed project would not impede or redirect flood flows. No impact is identified for this issue area and no further analysis is warranted.
- d) **No Impact.** The project site is within Zone X, which is an area determined to be outside of the 0.2 percent annual chance of a flood. The project site is not located near any large bodies of water. The Salton Sea is located approximately 37 miles northwest of the project site. Furthermore, the relatively flat project site is over 100 miles inland from the Pacific Ocean. Therefore, the proposed project would not risk release of pollutants due to project inundation by flood, tsunami or seiche. No impact is identified for this issue area.
- e) **No Impact.** The proposed project will not involve the use of groundwater nor require dewatering activities. Water to be used during project-related construction activities will be brought to the site and limited to the amount necessary for soil conditioning and to conduct dust control activities. Water is anticipated to be provided by adjacent IID irrigation canals or laterals in conformance with IID construction water acquisition requirements. Therefore, the proposed project will not conflict with or obstruct implementation of a water quality control plan or sustainable groundwater management plan. No impact is identified for this issue area.

XI. Land Use and Planning

Environmental Issue Area:	Potentially Significant Impact	Potentially Significant Unless Mitigation Incorporated	Less Than Significant Impact	No Impact
Would the project:				
a) Physically divide an established community?	<input type="checkbox"/>	<input type="checkbox"/>	<input type="checkbox"/>	<input checked="" type="checkbox"/>
b) Cause a significant environmental impact due to a conflict with any land use plan, policy, or regulation adopted for the purpose of avoiding or mitigating an environmental effect?	<input type="checkbox"/>	<input type="checkbox"/>	<input checked="" type="checkbox"/>	<input type="checkbox"/>

Impact Analysis

- a) **No Impact.** The proposed project is located in a sparsely populated, agriculturally zoned portion of Imperial County. There are no established residential communities located within or in the vicinity of the project site. Therefore, implementation of the proposed project would not divide an established community. No impact is identified for this issue area.
- b) **Less than Significant Impact.** The project site is currently designated by the General Plan as “Agriculture” and is zoned A-3-RE (Heavy Agriculture with a Renewable Energy Zone Overlay). Pursuant to Title 9, Division 5, Chapter 9, “Solar Energy Plants” and “Transmission lines, including supporting towers, poles microwave towers, utility substations” are uses that are permitted in the A-3 Zone, subject to approval of a CUP.

The County Land Use Ordinance, Division 17, includes the Renewable Energy Overlay Zone, which authorizes the development and operation of renewable energy projects, with an approved CUP. As shown on Figure 1, the project site is located entirely within the County’s Renewable Energy Overlay Zone. With approval of a CUP, the proposed solar facility would be consistent with the Imperial County Land Use Ordinance. Based on these considerations, the proposed project would not conflict with any applicable land use plan, policy, or regulation. Thus, a less than significant impact is identified for this issue area.

XII. Mineral Resources

Environmental Issue Area:	Potentially Significant Impact	Potentially Significant Unless Mitigation Incorporated	Less Than Significant Impact	No Impact
Would the project:				
a) Result in the loss of availability of a known mineral resource that would be of value to the region and the residents of the state?	<input type="checkbox"/>	<input type="checkbox"/>	<input type="checkbox"/>	<input checked="" type="checkbox"/>
b) Result in the loss of availability of a locally-important mineral resource recovery site delineated on a local general plan, specific plan, or other land use plan?	<input type="checkbox"/>	<input type="checkbox"/>	<input type="checkbox"/>	<input checked="" type="checkbox"/>

Impact Analysis

- a) **No Impact.** The project site is not used for mineral resource production. According to Figure 8: Imperial County Existing Mineral Resources of the Conservation and Open Space Element of the General Plan (County of Imperial 2016), no known mineral resources occur within the project site nor does the project site contain mapped mineral resources. Therefore, the proposed project would not result in the loss of availability of any known mineral resources that would be of value to the region and the residents of California nor would the proposed project result in the loss of availability of a locally important mineral resource. Thus, no impact is identified for this issue area and no further analysis is warranted.
- b) **No Impact.** Refer to response XIII. a) above.

XIII. Noise

Environmental Issue Area:	Potentially Significant Impact	Potentially Significant Unless Mitigation Incorporated	Less Than Significant Impact	No Impact
Would the project result in:				
a) Generation of a substantial temporary or permanent increase in ambient noise levels in the vicinity of the project in excess of standards established in the local general plan or noise ordinance, or applicable standards of other agencies?	<input type="checkbox"/>	<input type="checkbox"/>	<input checked="" type="checkbox"/>	<input type="checkbox"/>
b) Generation of excessive groundborne vibration or groundborne noise levels?	<input type="checkbox"/>	<input type="checkbox"/>	<input checked="" type="checkbox"/>	<input type="checkbox"/>
c) For a project located within the vicinity of a private airstrip or an airport land use plan or, where such a plan has not been adopted, within two miles of a public airport or public use airport, would the project expose people residing or working in the project area to excessive noise levels?	<input type="checkbox"/>	<input type="checkbox"/>	<input type="checkbox"/>	<input checked="" type="checkbox"/>

Impact Analysis

- a) **Less than Significant Impact.** The Imperial County Title 9 Land Use Ordinance, Division 7, Chapter 2, Section 90702.00 - Sound level limits, establishes one-hour average sound level limits for the County's land use zones. Agricultural/industrial operations are required to comply with the noise levels prescribed under the general industrial zones. Therefore, the proposed project will be required to maintain noise levels below 75 decibels (dB) (averaged over one hour) during any time of day.

The proposed project will also be expected to comply with the Noise Element of the General Plan which states that construction noise, from a single piece of equipment or a combination of equipment, shall not exceed 75 dB, when averaged over an eight hour period, and measured at the nearest sensitive receptor. Construction equipment operation is also limited to the hours of 7 a.m. to 7 p.m., Monday through Friday, and 9 a.m. to 5 p.m on Saturday. Nevertheless, the proposed project will result in the increase in ambient noise levels during construction. A noise report that will address the proposed project's potential noise impacts will be prepared and this issue will be addressed in the EIR.

- b) **Less than Significant Impact.** Groundborne vibration and noise could originate from earth movement during the construction phase of the proposed project. However, significant vibration is typically associated with activities such as blasting or the use of pile drivers, neither of which would be required during project construction. The proposed project would be expected to comply with all applicable requirements for long-term operation, as well as with measures to reduce excessive groundborne vibration and noise to ensure that the proposed project would not expose persons or structures to excessive groundborne vibration. Therefore, a less than significant impact has been identified for this issue area.
- c) **No Impact.** The project site is not located within 2 miles of a public airport or private airstrip. The nearest airport to the project site is the Calexico International Airport, located approximately 10 miles west of the project site. Therefore, the proposed project would not expose people residing or working in the project area to excess noise levels and no impact is identified for this issue area.

XIV. Population and Housing

Environmental Issue Area:	Potentially Significant Impact	Potentially Significant Unless Mitigation Incorporated	Less Than Significant Impact	No Impact
Would the project:				
a) Induce substantial unplanned population growth in an area, either directly (e.g., by proposing new homes and businesses) or indirectly (e.g., through extension of roads or other infrastructure)?	<input type="checkbox"/>	<input type="checkbox"/>	<input type="checkbox"/>	<input checked="" type="checkbox"/>
b) Displace substantial numbers of existing people or housing, necessitating the construction of replacement housing elsewhere?	<input type="checkbox"/>	<input type="checkbox"/>	<input type="checkbox"/>	<input checked="" type="checkbox"/>

Impact Analysis

- a) **No Impact.** Development of housing is not proposed as part of the proposed project. No full-time employees are required to operate the proposed project since the project facility will be monitored remotely. However, it is anticipated that maintenance of the facility will require minimal site presence to perform periodic visual inspections and minor repairs. On intermittent occasions, the presence of additional workers may be required for repairs or replacement of equipment and panel cleaning; however, due to the nature of the facility, such actions will likely occur infrequently. Therefore, the proposed project would not result in a substantial growth in the area, as the number of employees required to operate and maintain the facility is minimal. No impact is identified for this issue area.
- b) **No Impact.** No housing exists within the project site. Therefore, the proposed project would not displace any existing people or housing, which would require the construction of replacement housing elsewhere. No impact is identified for this issue area.

XV. Public Services

Environmental Issue Area:	Potentially Significant Impact	Potentially Significant Unless Mitigation Incorporated	Less Than Significant Impact	No Impact
a) Would the project result in substantial adverse physical impacts associated with the provision of new or physically altered governmental facilities, need for new or physically altered governmental facilities, the construction of which could cause significant environmental impacts, in order to maintain acceptable service ratios, response times or other performance objectives for any of the public services:				
i. Fire Protection?	<input type="checkbox"/>	<input type="checkbox"/>	<input checked="" type="checkbox"/>	<input type="checkbox"/>
ii. Police Protection?	<input checked="" type="checkbox"/>	<input type="checkbox"/>	<input type="checkbox"/>	<input type="checkbox"/>
iii. Schools?	<input type="checkbox"/>	<input type="checkbox"/>	<input type="checkbox"/>	<input type="checkbox"/>
iv. Parks?	<input type="checkbox"/>	<input type="checkbox"/>	<input type="checkbox"/>	<input checked="" type="checkbox"/>
v. Other public facilities?	<input type="checkbox"/>	<input type="checkbox"/>	<input type="checkbox"/>	<input checked="" type="checkbox"/>

Impact Analysis

- ai) **Less than Significant Impact.** Fire protection and emergency medical services in the project area are provided by the Imperial County Fire Department. The proposed site is located in the unincorporated area of Imperial County. According to the Seismic and Public Safety Element of the General Plan (County of Imperial 1997), the potential for a major fire in the unincorporated areas of the County is generally low. A 10,000-gallon aboveground water storage tank(s) would be installed on the project site as required by the Imperial County Fire Department. The water tank(s) would be sized to meet the requirements of the County of Imperial to supply sufficient fire suppression water during operations. Both the access and service roads (along the perimeter of the project facility) would have turnaround areas to allow clearance for fire trucks per fire department standards (70 feet by 70 feet, and minimum 20-foot-wide access road). The project applicant will be required to consult with the Fire Department to address any fire safety and service concerns so that adequate service is maintained. Based on these considerations, the project would not result in a need for fire facility expansion and a less than significant impact is identified for this issue area.
- aii) **Potentially Significant Impact.** Police protection services in the project area is provided by the Imperial County Sheriff's Department. Although the potential is low, the proposed project may attract vandals or other security risks and the increase in construction related traffic could increase demand on law enforcement services. Therefore, on-site security systems would be provided and access would be limited to the areas surrounding the project site during construction and operation, thereby minimizing the need for police surveillance. The proposed project's potentially significant impacts on sheriff services will be addressed in the EIR.
- aiii) **No Impact.** The proposed project does not include the development of residential land uses that would result in an increase in population or student generation. Additionally, construction of the proposed project would not result in an increase in student population within the Imperial County's School District since it is anticipated that construction workers would commute in during construction operations. Therefore, no impact is identified for this issue area and no further analysis is warranted.
- aiv) **No Impact.** Although maintenance of the project facility will require minimal site presence to perform periodic visual inspections and minor repairs, no full-time employees are required to operate the proposed project because the project facility will be monitored remotely. Therefore, substantial permanent increases in population that would adversely affect local parks is not expected. No impact is identified for this issue area and no further analysis is warranted.

- av) **No Impact.** Although maintenance of the project facility will require minimal site presence to perform periodic visual inspections and minor repairs, no full-time employees are required to operate the proposed project because the project facility will be monitored remotely. Therefore, substantial permanent increases in population that would adversely affect libraries and other public facilities (such as post offices) is not expected. The proposed project is not expected to have an impact on other public facilities such as post offices, and libraries. No impact is identified for this issue area and no further analysis is warranted.

XVI. Recreation

Environmental Issue Area:	Potentially Significant Impact	Potentially Significant Unless Mitigation Incorporated	Less Than Significant Impact	No Impact
Would the project:				
a) Would the project increase the use of existing neighborhood and regional parks or other recreational facilities such that substantial physical deterioration of the facility would occur or be accelerated?	<input type="checkbox"/>	<input type="checkbox"/>	<input type="checkbox"/>	<input checked="" type="checkbox"/>
b) Does the project include recreational facilities or require the construction or expansion of recreational facilities, which might have an adverse physical effect on the environment?	<input type="checkbox"/>	<input type="checkbox"/>	<input type="checkbox"/>	<input checked="" type="checkbox"/>

Impact Analysis

- a) **No Impact.** The proposed project would not generate new employment on a long-term basis. As such, the proposed project would not significantly increase the use or accelerate the deterioration of regional parks or other recreational facilities. The temporary increase of population during construction that might be caused by an influx of workers would be minimal and not cause a detectable increase in the use of parks. Additionally, the proposed project would not include or require the expansion of recreational facilities. No impact is identified for this issue area and no further analysis is warranted.
- b) **No Impact.** Refer to response XVI. a) above.

XVII. Transportation

Environmental Issue Area:	Potentially Significant Impact	Potentially Significant Unless Mitigation Incorporated	Less Than Significant Impact	No Impact
Would the project:				
a) Conflict with a program plan, ordinance or policy addressing the circulation system, including transit, roadway, bicycle and pedestrian facilities?	<input checked="" type="checkbox"/>	<input type="checkbox"/>	<input type="checkbox"/>	<input type="checkbox"/>
b) Conflict with or be inconsistent with CEQA Guidelines section 15064.3, subdivision (b)?	<input checked="" type="checkbox"/>	<input type="checkbox"/>	<input type="checkbox"/>	<input type="checkbox"/>
c) Substantially increase hazards due to a geometric design feature (e.g., sharp curves or dangerous intersections) or incompatible uses (e.g., farm equipment)?	<input type="checkbox"/>	<input type="checkbox"/>	<input type="checkbox"/>	<input checked="" type="checkbox"/>
d) Result in inadequate emergency access?	<input type="checkbox"/>	<input type="checkbox"/>	<input checked="" type="checkbox"/>	<input type="checkbox"/>

Impact Analysis

- a) **Potentially Significant Impact.** Construction of the proposed project would result in a small increase of traffic to the area, which may result in a potentially significant impact. Therefore, a traffic impact study that will address the proposed project's potential impacts on transportation will be prepared, and this issue will be addressed in the EIR.
- b) **Potentially Significant Impact.** Section 15064.3(b) of the CEQA Guidelines provides guidance on determining the significance of transportation impacts and focuses on the use of vehicle miles traveled (VMT), which is defined as the amount and distance of automobile travel associated with a project. Given the nature of the project, after construction, there would be a nominal amount of vehicle trips generated by the project. Once the proposed project is implemented, the proposed project would require intermittent maintenance requiring a negligible amount of traffic trips on an annual basis. However minimal, the proposed project would increase the number of vehicular trips related to construction and the need for intermittent maintenance on an annual basis. Therefore, this issue is potentially significant and will be addressed in the traffic impact study and EIR analysis.
- c) **No Impact.** To accommodate emergency access, PV panels would be spaced to maintain proper clearance. Internal access roads, up to 30-feet wide, would be constructed along the perimeter fence and solar panels to facilitate vehicle access and maneuverability for emergency unit vehicles. Access roads would be graded and compacted (native soils) as required for construction, operations, maintenance, and emergency vehicle access. These access roads would not increase hazards because of design features or incompatible uses. Therefore, no impact will occur.
- d) **Less than Significant Impact.** To accommodate emergency access, PV panels would be spaced to maintain proper clearance. 30-foot wide internal access roads would be constructed along the perimeter fence and solar panels to facilitate vehicle access and maneuverability for emergency unit vehicles. The internal access roads would be graded and compacted (native soils) as required for construction, operations, maintenance, and emergency vehicle access. The access and service roads would also have turnaround areas at any dead-end to allow clearance for fire trucks per fire department standards. Based on this context, impacts are considered less than significant.

XVIII. Tribal Cultural Resources

Environmental Issue Area:	Potentially Significant Impact	Potentially Significant Unless Mitigation Incorporated	Less Than Significant Impact	No Impact
<i>Would the project cause a substantial adverse change in the significance of a tribal cultural resource defined in Public Resources Code section 21074 as either a site, feature, place, cultural landscape that is geographically defined in terms of the size and scope of the landscape, sacred place, or object with cultural value to a California Native American tribe, and that is:</i>				
a) Listed or eligible for listing in the California Register of Historical Resources, or in a local register of historical resources as defined in Public Resources Code section 5020.1(k)?	<input checked="" type="checkbox"/>	<input type="checkbox"/>	<input type="checkbox"/>	<input type="checkbox"/>
b) A resource determined by the lead agency, in its discretion and supported by substantial evidence, to be significant pursuant to criteria set forth in subdivision (c) of Public Resources Code Section 5024.1. In applying the criteria set forth in subdivision (c) of Public Resources Code Section 5024.1, the lead agency shall consider the significance of the resource to a California Native American tribe?	<input checked="" type="checkbox"/>	<input type="checkbox"/>	<input type="checkbox"/>	<input type="checkbox"/>

Impact Analysis

a-b) **Potentially Significant Impact.** Assembly Bill 52 was passed in 2014 and took effect July 1, 2015. It established a new category of environmental resources that must be considered under CEQA called tribal cultural resources (Public Resources Code 21074) and established a process for consulting with Native American tribes and groups regarding those resources. Assembly Bill 52 requires a lead agency to begin consultation with a California Native American tribe that is traditionally and culturally affiliated with the geographic area of the proposed project.

In accordance with AB 52, Imperial County, as the CEQA lead agency, sent an AB 52 consultation request letter to the Quechan Indian Tribe on March 26, 2021. On April 1, 2021, the Quechan Indian Tribe requested consultation with the County on the project. The County is in the process of consulting with the Quechan Indian Tribe on the project. This issue will be further analyzed in the EIR.

XIX. Utilities and Service Systems

Environmental Issue Area:	Potentially Significant Impact	Potentially Significant Unless Mitigation Incorporated	Less Than Significant Impact	No Impact
Would the project:				
a) Require or result in the relocation or construction of new or expanded water, wastewater treatment or storm water drainage, electric power, natural gas, or telecommunications facilities, the construction or relocation of which could cause significant environmental effects?	<input checked="" type="checkbox"/>	<input type="checkbox"/>	<input type="checkbox"/>	<input type="checkbox"/>
b) Have sufficient water supplies available to serve the project and reasonably foreseeable future development during normal, dry and multiple dry years?	<input checked="" type="checkbox"/>	<input type="checkbox"/>	<input type="checkbox"/>	<input type="checkbox"/>
c) Result in a determination by the wastewater treatment provider, which serves or may serve the project that it has adequate capacity to serve the project's projected demand in addition to the provider's existing commitments?	<input type="checkbox"/>	<input type="checkbox"/>	<input checked="" type="checkbox"/>	<input type="checkbox"/>
d) Generate solid waste in excess of State or local standards, or in excess of the capacity of local infrastructure, or otherwise impair the attainment of solid waste reduction goals?	<input type="checkbox"/>	<input type="checkbox"/>	<input checked="" type="checkbox"/>	<input type="checkbox"/>
e) Comply with federal, state, and local management and reduction statutes and regulations related to solid waste?	<input type="checkbox"/>	<input type="checkbox"/>	<input checked="" type="checkbox"/>	<input type="checkbox"/>

Impact Analysis

- a) **Potentially Significant Impact.** No IID drains or canals will be impacted by the proposed project. The proposed project does not require expanded or new storm drainage facilities because the proposed solar facility would not generate a significant increase in the amount of impervious surfaces that would increase runoff during storm events and exceed the capacity of existing or planned stormwater drainage systems. Water from solar panel washing would continue to percolate through the ground, as a majority of the surfaces within the project site would remain pervious.

The wastewater generated during construction would be contained within portable toilet facilities and disposed of at an approved site. The minimal volume of wastewater generated during construction would not require the relocation expansion, or construction of wastewater treatment facilities. Further, no habitable structures (e.g. housing or O&M buildings) are proposed on the project site. Therefore, the proposed project would not require or result in the relocation or construction of new or expanded electric power, natural gas, or telecommunications facilities.



Although water for solar panel washing and fire protection (on-site storage) during project operation is not anticipated to result in a significant increase in water demand/use, IID would provide the water required for operations and maintenance and potable water will be trucked onto the site. Thus, a potentially significant impact is identified for the availability of sufficient water supplies to serve the proposed project for the reasonably foreseeable future. A water supply assessment that will address the proposed project's potential impacts on water supplies will be prepared and included in the EIR analysis.

- b) **Potentially Significant Impact.** Refer to response XIX. a) above.
- c) **Less than Significant Impact.** The proposed project would generate a minimal volume of wastewater during construction. During construction activities, wastewater would be contained within portable toilet facilities and disposed of at an approved site. Further, no habitable structures (e.g. housing or O&M buildings) are proposed on the project site; therefore, there would be no wastewater generation from the proposed project during operation. The proposed project would not exceed wastewater treatment requirements of the RWQCB. Therefore, a less than significant impact is identified for this issue area.
- d) **Less than Significant Impact.** Solid waste generation would be minor for the construction and operation of the proposed project. Solid waste will be disposed of using a locally-licensed waste hauling service, most likely Allied Waste. Trash would likely be hauled to the Calexico Solid Waste Site (13-AA-0004) located approximately 13 miles west of the proposed project in Calexico. The Calexico Solid Waste Site has approximately 1,561,235 cubic yards of remaining capacity and is estimated to remain in operation through 2179 (CalRecycle n.d.). Therefore, there is ample landfill capacity in the County to receive the minor amount of solid waste generated by construction and operation of the proposed project.

Additionally, because the proposed project would generate solid waste during construction and operation, they will be required to comply with state and local requirements for waste reduction and recycling; including the 1989 California Integrated Waste Management Act and the 1991 California Solid Waste Reuse and Recycling Access Act of 1991. Also, conditions of the conditional use permit will contain provisions for recycling and diversion of Imperial County construction waste policies. Therefore, a less than significant impact is identified for this issue area.

- e) **Less than Significant Impact.** Refer to response XIX. d) above.

XX. Wildfire

Environmental Issue Area:	Potentially Significant Impact	Potentially Significant Unless Mitigation Incorporated	Less Than Significant Impact	No Impact
<i>If located in or near state responsibility areas or lands classified as very high fire hazard severity zones, would the project:</i>				
a) Substantially impair an adopted emergency response plan or emergency evacuation plan?	<input type="checkbox"/>	<input type="checkbox"/>	<input type="checkbox"/>	<input checked="" type="checkbox"/>
b) Due to slope, prevailing winds, and other factors, exacerbate wildfire risks, and thereby expose project occupants to, pollutant concentrations from a wildfire or the uncontrolled spread of a wildfire?	<input type="checkbox"/>	<input type="checkbox"/>	<input type="checkbox"/>	<input checked="" type="checkbox"/>
c) Require the installation or maintenance of associated infrastructure (such as roads, fuel breaks, emergency water sources, power lines or other utilities) that may exacerbate fire risk or that may result in temporary or ongoing impacts to the environment?	<input type="checkbox"/>	<input type="checkbox"/>	<input checked="" type="checkbox"/>	<input type="checkbox"/>
d) Expose people or structures to significant risks, including downslope or downstream flooding or landslides, as a result of runoff, post-fire slope instability, or drainage changes?	<input type="checkbox"/>	<input type="checkbox"/>	<input type="checkbox"/>	<input checked="" type="checkbox"/>

Impact Analysis

- a) **No Impact.** According to the Fire Hazard Severity Zone Viewer provided by the California Department of Forestry and Fire Protection, the proposed project is not located in or near state responsibility areas or lands classified as very high hazard severity zones (California Department of Forestry and Fire Protection 2020). Therefore, the proposed project would not substantially impair an adopted emergency response plan or emergency evacuation plan. No impact is identified for this issue area.
- b) **No Impact.** The proposed project is not located in or near state responsibility areas or lands classified as very high hazard severity zones (California Department of Forestry and Fire Protection 2020). Therefore, the proposed project would not exacerbate wildfire risks. No impact is identified for this issue area.
- c) **Less than Significant Impact.** Fire protection and emergency medical services in the area are provided by the Imperial County Fire Department. The proposed project is not located in or near state responsibility areas or lands classified as very high hazard severity zones (California Department of Forestry and Fire Protection 2020). Further, the proposed project is located in an unincorporated area of Imperial County, which has a generally low potential for a major fire (County of Imperial 2016).

The project involves the installation of solar PV panels on fixed frames or single-axis horizontal trackers, an on-site substation and inverters, transformers, underground electrical cables, and 10,000-gallon aboveground water storage tank as required by the Imperial County Fire Department. The water tank(s) would be sized to meet the requirements of the County of Imperial to supply sufficient fire suppression water during operations. Further, the project site would be accessible from a primary and secondary (if required) access driveway that would have turnaround areas to allow clearance for fire trucks per fire department standards (30-foot-wide access road) and 30-foot double swing gates with keyed entry. In addition, operation and maintenance would not affect the ability of fire personnel to respond to fires. Therefore, the

proposed project would not exacerbate fire risk and would continue to be adequately supported by the existing fire protection services. A less than significant impact is identified for this issue area.

- d) **No Impact.** The proposed project is not located in or near state responsibility areas or lands classified as very high hazard severity zones (California Department of Forestry and Fire Protection 2020). Additionally, the proposed project would not expose people or structures to significant risks, including downslope or downstream flooding or landslides, as a result of runoff, post-fire slope instability, or drainage changes. No impact is identified for this issue area and no further analysis is warranted.

XXI. Mandatory Findings of Significance

Environmental Issue Area:	Potentially Significant Impact	Potentially Significant Unless Mitigation Incorporated	Less Than Significant Impact	No Impact
Would the project:				
a) Does the project have the potential to substantially degrade the quality of the environment, substantially reduce the habitat of a fish or wildlife species, cause a fish or wildlife population to drop below self-sustaining levels, threaten to eliminate a plant or animal community, substantially reduce the number or restrict the range of a rare or endangered plant or animal or eliminate important examples of the major periods of California history or prehistory?	<input checked="" type="checkbox"/>	<input type="checkbox"/>	<input type="checkbox"/>	<input type="checkbox"/>
b) Does the project have impacts that are individually limited, but cumulatively considerable ("Cumulatively considerable" means that the incremental effects of a project are considerable when viewed in connection with the effects of past projects, the effects of other current projects, and the effects of probable future projects)?	<input checked="" type="checkbox"/>	<input type="checkbox"/>	<input type="checkbox"/>	<input type="checkbox"/>
c) Does the project have environmental effects, which will cause substantial adverse effects on human beings, either directly or indirectly?	<input checked="" type="checkbox"/>	<input type="checkbox"/>	<input type="checkbox"/>	<input type="checkbox"/>

Impact Analysis

- a) **Potentially Significant Impact.** The proposed project has the potential to result in significant environmental effects on biological resources and cultural resources, which could directly or indirectly cause adverse effects on the environment. These issues will be further evaluated in the EIR.
- b) **Potentially Significant Impact.** Implementation of the proposed project has the potential to result in impacts related to: aesthetics, agricultural resources, air quality, biological resources, cultural resources, geology/soils, greenhouse gas emissions, hydrology and water quality, public services, transportation, tribal cultural resources, and utilities/service systems.. The proposed project has the potential to result in cumulative impacts with regards to the identified issue areas. Cumulative impacts will be discussed and further analyzed in the EIR.
- c) **Potentially Significant Impact.** Implementation of the proposed project has the potential to result in impacts related to: air quality and geology/soils. These potential environmental effects could cause substantial adverse effects on human beings. These issues will be further evaluated in the EIR.

References

- California Department of Conservation (DOC). 2016a. *Imperial County Important Farmland 2016*. Accessed March 2021.
- 2016b. *Imperial County Williamson Act FY 2016/2017*. Accessed March 2021.
- California Department of Forestry and Fire Protection. 2020. Fire Hazard Severity Zone Viewer. <https://gis.data.ca.gov/datasets/789d5286736248f69c4515c04f58f414>. Accessed March 2021.
- California Department of Resources Recycling and Recovery (CalRecycle). n.d. Facility/Site Summary Details: Niland Solid Waste Site (13-AA-0009). <https://www2.calrecycle.ca.gov/SolidWaste/SiteActivity/Details/4179?siteID=591>. Accessed March 2021.
- California Department of Transportation (Caltrans). 2018. California Scenic Highway Mapping System. <https://dot.ca.gov/programs/design/lap-landscape-architecture-and-community-livability/lap-liv-i-scenic-highways>. Accessed March 2021.
- County of Imperial. 1997. County of Imperial General Plan. Seismic and Public Safety Element. <https://www.icpds.com/assets/planning/seismic-and-public-safety.pdf>. Accessed March 2021.
- 2016. County of Imperial General Plan. Conservation and Open Space Element. <https://www.icpds.com/planning/land-use-documents/general-plan/conservation-and-open-space-element>. Accessed March 2021.
- 2019a. Imperial County Land Use Ordinance: Title 9, Division 4. https://library.municode.com/ca/imperial_county/codes/code_of_ordinances?nodeId=TIT9LAUSCO_DIV17GEPR. Accessed March 2021.
- 2019b. Imperial County Land Use Ordinance: Title 9, Division 17. https://library.municode.com/ca/imperial_county/codes/code_of_ordinances?nodeId=TIT9LAUSCO_DIV17GEPR. Accessed March 2021.
- Department of Toxic Substances Control. 2021. EnviroStor – Hazardous Waste and Substances Site List (Cortese). https://www.envirostor.dtsc.ca.gov/public/search?cmd=search&reporttype=CORTESE&site_type=CSITES,FUDS&status=ACT,BKLG,COM&reporttitle=HAZARDOUS+WASTE+AND+SUBSTANCES+SITE+LIST+%28CORTESE%29. Accessed March 2021.
- Federal Emergency Management Agency (FEMA). 2008. Flood Insurance Rate Map (Panel 06025C2125C). <https://msc.fema.gov/portal/search?AddressQuery=2307%20CA-98%2C%20Holtville%2C%20CA%2092250#searchresultsanchor>. Accessed March 2021.
- Historic Aerials. 2021. Historic Aerials. <https://www.historicaerials.com/viewer>. Accessed March 2021.

List of Preparers

This Initial Study was prepared for the Imperial County Planning and Development Services Department by HDR at 591 Camino de la Reina, Suite 300, San Diego, CA 92108. The following professionals participated in its preparation:

Imperial County Planning and Development Services Department

Jim Minnick, Planning and Development Services Director

Michael Abraham, AICP, Assistant Planning and Development Services Director

Diana Robinson, Planner III

HDR

Tim Gnibus, Principal

Sharyn Del Rosario, Project Manager

Elaine Lee, Environmental Planner

Anders Burvall, Senior Geographic Information Systems Analyst

Renee Stueber, Document Production Administrator

Comment Letters Received on Notice of Preparation



NATIVE AMERICAN HERITAGE COMMISSION

May 5, 2021

Diana Robinson
Imperial County
801 Main Street
El Centro, CA 92243

CHAIRPERSON
Laura Miranda
Luiseño

VICE CHAIRPERSON
Reginald Pagaling
Chumash

SECRETARY
Merrí Lopez-Keifer
Luiseño

PARLIAMENTARIAN
Russell Atebery
Karuk

COMMISSIONER
William Mungary
Paiute/White Mountain
Apache

COMMISSIONER
Julie Tumamait-Stenslie
Chumash

COMMISSIONER
[Vacant]

COMMISSIONER
[Vacant]

COMMISSIONER
[Vacant]

EXECUTIVE SECRETARY
Christina Snider
Pomo

NAHC HEADQUARTERS
1550 Harbor Boulevard
Suite 100
West Sacramento,
California 95691
(916) 373-3710
nahc@nahc.ca.gov
NAHC.ca.gov

Re: 2021050018, VEGA SES 4 Solar Energy Project, Imperial County

Dear Ms. Robinson:

The Native American Heritage Commission (NAHC) has received the Notice of Preparation (NOP), Draft Environmental Impact Report (DEIR) or Early Consultation for the project referenced above. The California Environmental Quality Act (CEQA) (Pub. Resources Code §21000 et seq.), specifically Public Resources Code §21084.1, states that a project that may cause a substantial adverse change in the significance of a historical resource, is a project that may have a significant effect on the environment. (Pub. Resources Code § 21084.1; Cal. Code Regs., tit.14, §15064.5 (b) (CEQA Guidelines § 15064.5 (b)). If there is substantial evidence, in light of the whole record before a lead agency, that a project may have a significant effect on the environment, an Environmental Impact Report (EIR) shall be prepared. (Pub. Resources Code §21080 (d); Cal. Code Regs., tit. 14, § 5064 subd.(a)(1) (CEQA Guidelines § 15064 (a)(1)). In order to determine whether a project will cause a substantial adverse change in the significance of a historical resource, a lead agency will need to determine whether there are historical resources within the area of potential effect (APE).

CEQA was amended significantly in 2014. Assembly Bill 52 (Gatto, Chapter 532, Statutes of 2014) (AB 52) amended CEQA to create a separate category of cultural resources, "tribal cultural resources" (Pub. Resources Code §21074) and provides that a project with an effect that may cause a substantial adverse change in the significance of a tribal cultural resource is a project that may have a significant effect on the environment. (Pub. Resources Code §21084.2). Public agencies shall, when feasible, avoid damaging effects to any tribal cultural resource. (Pub. Resources Code §21084.3 (a)). **AB 52 applies to any project for which a notice of preparation, a notice of negative declaration, or a mitigated negative declaration is filed on or after July 1, 2015.** If your project involves the adoption of or amendment to a general plan or a specific plan, or the designation or proposed designation of open space, on or after March 1, 2005, it may also be subject to Senate Bill 18 (Burton, Chapter 905, Statutes of 2004) (SB 18). **Both SB 18 and AB 52 have tribal consultation requirements.** If your project is also subject to the federal National Environmental Policy Act (42 U.S.C. § 4321 et seq.) (NEPA), the tribal consultation requirements of Section 106 of the National Historic Preservation Act of 1966 (154 U.S.C. 300101, 36 C.F.R. §800 et seq.) may also apply.

The NAHC recommends consultation with California Native American tribes that are traditionally and culturally affiliated with the geographic area of your proposed project as early as possible in order to avoid inadvertent discoveries of Native American human remains and best protect tribal cultural resources. Below is a brief summary of portions of AB 52 and SB 18 as well as the NAHC's recommendations for conducting cultural resources assessments.

Consult your legal counsel about compliance with AB 52 and SB 18 as well as compliance with any other applicable laws.

RECEIVED

MAY 10 2021

**IMPERIAL COUNTY
PLANNING & DEVELOPMENT SERVICES**

AB 52 has added to CEQA the additional requirements listed below, along with many other requirements:

- 1. Fourteen Day Period to Provide Notice of Completion of an Application/Decision to Undertake a Project:** Within fourteen (14) days of determining that an application for a project is complete or of a decision by a public agency to undertake a project, a lead agency shall provide formal notification to a designated contact of, or tribal representative of, traditionally and culturally affiliated California Native American tribes that have requested notice, to be accomplished by at least one written notice that includes:

 - a. A brief description of the project.
 - b. The lead agency contact information.
 - c. Notification that the California Native American tribe has 30 days to request consultation. (Pub. Resources Code §21080.3.1 (d)).
 - d. A "California Native American tribe" is defined as a Native American tribe located in California that is on the contact list maintained by the NAHC for the purposes of Chapter 905 of Statutes of 2004 (SB 18). (Pub. Resources Code §21073).
- 2. Begin Consultation Within 30 Days of Receiving a Tribe's Request for Consultation and Before Releasing a Negative Declaration, Mitigated Negative Declaration, or Environmental Impact Report:** A lead agency shall begin the consultation process within 30 days of receiving a request for consultation from a California Native American tribe that is traditionally and culturally affiliated with the geographic area of the proposed project. (Pub. Resources Code §21080.3.1, subs. (d) and (e)) and prior to the release of a negative declaration, mitigated negative declaration or Environmental Impact Report. (Pub. Resources Code §21080.3.1(b)).

 - a. For purposes of AB 52, "consultation shall have the same meaning as provided in Gov. Code §65352.4 (SB 18). (Pub. Resources Code §21080.3.1 (b)).
- 3. Mandatory Topics of Consultation If Requested by a Tribe:** The following topics of consultation, if a tribe requests to discuss them, are mandatory topics of consultation:

 - a. Alternatives to the project.
 - b. Recommended mitigation measures.
 - c. Significant effects. (Pub. Resources Code §21080.3.2 (a)).
- 4. Discretionary Topics of Consultation:** The following topics are discretionary topics of consultation:

 - a. Type of environmental review necessary.
 - b. Significance of the tribal cultural resources.
 - c. Significance of the project's impacts on tribal cultural resources.
 - d. If necessary, project alternatives or appropriate measures for preservation or mitigation that the tribe may recommend to the lead agency. (Pub. Resources Code §21080.3.2 (a)).
- 5. Confidentiality of Information Submitted by a Tribe During the Environmental Review Process:** With some exceptions, any information, including but not limited to, the location, description, and use of tribal cultural resources submitted by a California Native American tribe during the environmental review process shall not be included in the environmental document or otherwise disclosed by the lead agency or any other public agency to the public, consistent with Government Code §6254 (r) and §6254.10. Any information submitted by a California Native American tribe during the consultation or environmental review process shall be published in a confidential appendix to the environmental document unless the tribe that provided the information consents, in writing, to the disclosure of some or all of the information to the public. (Pub. Resources Code §21082.3 (c)(1)).
- 6. Discussion of Impacts to Tribal Cultural Resources in the Environmental Document:** If a project may have a significant impact on a tribal cultural resource, the lead agency's environmental document shall discuss both of the following:

 - a. Whether the proposed project has a significant impact on an identified tribal cultural resource.
 - b. Whether feasible alternatives or mitigation measures, including those measures that may be agreed to pursuant to Public Resources Code §21082.3, subdivision (a), avoid or substantially lessen the impact on the identified tribal cultural resource. (Pub. Resources Code §21082.3 (b)).

- 7. Conclusion of Consultation:** Consultation with a tribe shall be considered concluded when either of the following occurs:
- a. The parties agree to measures to mitigate or avoid a significant effect, if a significant effect exists, on a tribal cultural resource; or
 - b. A party, acting in good faith and after reasonable effort, concludes that mutual agreement cannot be reached. (Pub. Resources Code §21080.3.2 (b)).
- 8. Recommending Mitigation Measures Agreed Upon in Consultation in the Environmental Document:** Any mitigation measures agreed upon in the consultation conducted pursuant to Public Resources Code §21080.3.2 shall be recommended for inclusion in the environmental document and in an adopted mitigation monitoring and reporting program, if determined to avoid or lessen the impact pursuant to Public Resources Code §21082.3, subdivision (b), paragraph 2, and shall be fully enforceable. (Pub. Resources Code §21082.3 (a)).
- 9. Required Consideration of Feasible Mitigation:** If mitigation measures recommended by the staff of the lead agency as a result of the consultation process are not included in the environmental document or if there are no agreed upon mitigation measures at the conclusion of consultation, or if consultation does not occur, and if substantial evidence demonstrates that a project will cause a significant effect to a tribal cultural resource, the lead agency shall consider feasible mitigation pursuant to Public Resources Code §21084.3 (b). (Pub. Resources Code §21082.3 (e)).
- 10. Examples of Mitigation Measures That, If Feasible, May Be Considered to Avoid or Minimize Significant Adverse Impacts to Tribal Cultural Resources:**
- a. Avoidance and preservation of the resources in place, including, but not limited to:
 - i. Planning and construction to avoid the resources and protect the cultural and natural context.
 - ii. Planning greenspace, parks, or other open space, to incorporate the resources with culturally appropriate protection and management criteria.
 - b. Treating the resource with culturally appropriate dignity, taking into account the tribal cultural values and meaning of the resource, including, but not limited to, the following:
 - i. Protecting the cultural character and integrity of the resource.
 - ii. Protecting the traditional use of the resource.
 - iii. Protecting the confidentiality of the resource.
 - c. Permanent conservation easements or other interests in real property, with culturally appropriate management criteria for the purposes of preserving or utilizing the resources or places.
 - d. Protecting the resource. (Pub. Resource Code §21084.3 (b)).
 - e. Please note that a federally recognized California Native American tribe or a non-federally recognized California Native American tribe that is on the contact list maintained by the NAHC to protect a California prehistoric, archaeological, cultural, spiritual, or ceremonial place may acquire and hold conservation easements if the conservation easement is voluntarily conveyed. (Civ. Code §815.3 (c)).
 - f. Please note that it is the policy of the state that Native American remains and associated grave artifacts shall be repatriated. (Pub. Resources Code §5097.991).
- 11. Prerequisites for Certifying an Environmental Impact Report or Adopting a Mitigated Negative Declaration or Negative Declaration with a Significant Impact on an Identified Tribal Cultural Resource:** An Environmental Impact Report may not be certified, nor may a mitigated negative declaration or a negative declaration be adopted unless one of the following occurs:
- a. The consultation process between the tribes and the lead agency has occurred as provided in Public Resources Code §21080.3.1 and §21080.3.2 and concluded pursuant to Public Resources Code §21080.3.2.
 - b. The tribe that requested consultation failed to provide comments to the lead agency or otherwise failed to engage in the consultation process.
 - c. The lead agency provided notice of the project to the tribe in compliance with Public Resources Code §21080.3.1 (d) and the tribe failed to request consultation within 30 days. (Pub. Resources Code §21082.3 (d)).

The NAHC's PowerPoint presentation titled, "Tribal Consultation Under AB 52: Requirements and Best Practices" may be found online at: http://nahc.ca.gov/wp-content/uploads/2015/10/AB52TribalConsultation_CalePAPDF.pdf

SB 18

SB 18 applies to local governments and requires local governments to contact, provide notice to, refer plans to, and consult with tribes prior to the adoption or amendment of a general plan or a specific plan, or the designation of open space. (Gov. Code §65352.3). Local governments should consult the Governor's Office of Planning and Research's "Tribal Consultation Guidelines," which can be found online at: https://www.opr.ca.gov/docs/09_14_05_Updated_Guidelines_922.pdf.

Some of SB 18's provisions include:

1. **Tribal Consultation**: If a local government considers a proposal to adopt or amend a general plan or a specific plan, or to designate open space it is required to contact the appropriate tribes identified by the NAHC by requesting a "Tribal Consultation List." If a tribe, once contacted, requests consultation the local government must consult with the tribe on the plan proposal. **A tribe has 90 days from the date of receipt of notification to request consultation unless a shorter timeframe has been agreed to by the tribe.** (Gov. Code §65352.3 (a)(2)).
2. **No Statutory Time Limit on SB 18 Tribal Consultation**. There is no statutory time limit on SB 18 tribal consultation.
3. **Confidentiality**: Consistent with the guidelines developed and adopted by the Office of Planning and Research pursuant to Gov. Code §65040.2, the city or county shall protect the confidentiality of the information concerning the specific identity, location, character, and use of places, features and objects described in Public Resources Code §5097.9 and §5097.993 that are within the city's or county's jurisdiction. (Gov. Code §65352.3 (b)).
4. **Conclusion of SB 18 Tribal Consultation**: Consultation should be concluded at the point in which:
 - a. The parties to the consultation come to a mutual agreement concerning the appropriate measures for preservation or mitigation; or
 - b. Either the local government or the tribe, acting in good faith and after reasonable effort, concludes that mutual agreement cannot be reached concerning the appropriate measures of preservation or mitigation. (Tribal Consultation Guideline, Governor's Office of Planning and Research (2005) at p. 18).

Agencies should be aware that neither AB 52 nor SB 18 precludes agencies from initiating tribal consultation with tribes that are traditionally and culturally affiliated with their jurisdictions before the timeframes provided in AB 52 and SB 18. For that reason, we urge you to continue to request Native American Tribal Contact Lists and "Sacred Lands File" searches from the NAHC. The request forms can be found online at: <http://nahc.ca.gov/resources/forms/>.

NAHC Recommendations for Cultural Resources Assessments

To adequately assess the existence and significance of tribal cultural resources and plan for avoidance, preservation in place, or barring both, mitigation of project-related impacts to tribal cultural resources, the NAHC recommends the following actions:

1. Contact the appropriate regional California Historical Research Information System (CHRIS) Center (http://ohp.parks.ca.gov/?page_id=1068) for an archaeological records search. The records search will determine:
 - a. If part or all of the APE has been previously surveyed for cultural resources.
 - b. If any known cultural resources have already been recorded on or adjacent to the APE.
 - c. If the probability is low, moderate, or high that cultural resources are located in the APE.
 - d. If a survey is required to determine whether previously unrecorded cultural resources are present.
2. If an archaeological inventory survey is required, the final stage is the preparation of a professional report detailing the findings and recommendations of the records search and field survey.
 - a. The final report containing site forms, site significance, and mitigation measures should be submitted immediately to the planning department. All information regarding site locations, Native American human remains, and associated funerary objects should be in a separate confidential addendum and not be made available for public disclosure.
 - b. The final written report should be submitted within 3 months after work has been completed to the appropriate regional CHRIS center.

3. Contact the NAHC for:
 - a. A Sacred Lands File search. Remember that tribes do not always record their sacred sites in the Sacred Lands File, nor are they required to do so. A Sacred Lands File search is not a substitute for consultation with tribes that are traditionally and culturally affiliated with the geographic area of the project's APE.
 - b. A Native American Tribal Consultation List of appropriate tribes for consultation concerning the project site and to assist in planning for avoidance, preservation in place, or, failing both, mitigation measures.

4. Remember that the lack of surface evidence of archaeological resources (including tribal cultural resources) does not preclude their subsurface existence.
 - a. Lead agencies should include in their mitigation and monitoring reporting program plan provisions for the identification and evaluation of inadvertently discovered archaeological resources per Cal. Code Regs., tit. 14, §15064.5(f) (CEQA Guidelines §15064.5(f)). In areas of identified archaeological sensitivity, a certified archaeologist and a culturally affiliated Native American with knowledge of cultural resources should monitor all ground-disturbing activities.
 - b. Lead agencies should include in their mitigation and monitoring reporting program plans provisions for the disposition of recovered cultural items that are not burial associated in consultation with culturally affiliated Native Americans.
 - c. Lead agencies should include in their mitigation and monitoring reporting program plans provisions for the treatment and disposition of inadvertently discovered Native American human remains. Health and Safety Code §7050.5, Public Resources Code §5097.98, and Cal. Code Regs., tit. 14, §15064.5, subdivisions (d) and (e) (CEQA Guidelines §15064.5, subs. (d) and (e)) address the processes to be followed in the event of an inadvertent discovery of any Native American human remains and associated grave goods in a location other than a dedicated cemetery.

If you have any questions or need additional information, please contact me at my email address:
Andrew.Green@nahc.ca.gov.

Sincerely,



Andrew Green
Cultural Resources Analyst

cc: State Clearinghouse



COUNTY OF
IMPERIAL

DEPARTMENT OF
PUBLIC WORKS

155 S. 11th Street
El Centro, CA
92243

Tel: (442) 265-1818
Fax: (442) 265-1858

Follow Us:



[www.facebook.com/
ImperialCountyDPW/](http://www.facebook.com/ImperialCountyDPW/)



[https://twitter.com/
CountyDpw/](https://twitter.com/CountyDpw/)



Public Works works for the Public

May 19, 2021

Imperial County Planning & Development Services
Mr. Jim Minnick, Director
801 Main Street
El Centro, CA 92243

RECEIVED

MAY 19 2021

IMPERIAL COUNTY

PLANNING & DEVELOPMENT SERVICES

Attention: Diana Robinson, Planner III

**SUBJECT: Vega SES 4 Solar Project – Apex Energy Solutions, LLC;
CUP 20-0020**

Located approximately 10 miles east of Calexico
APN's 059-300-015, 059-300-017, and 059-290-010

Dear Mr. Minnick:

This letter is in response to your submittal received by this Department on March 25, 2021 for the above mentioned project. The Applicant proposes to construct a 100-megawatt, alternating-current, solar photovoltaic energy generation facility on approximately 531.53 acres of land. The project would include a 100MW/400MWh battery storage facility.

Department staff has reviewed the package information and the following comments shall be Conditions of Approval:

1. The Applicant shall acquire proper easements from adjacent property owners for the installation of any proposed transmission lines.
2. All survey monuments, including those within the interior of the project, shall be protected, and their locations shall remain accessible to any surveyor throughout the duration of the project. Section 8774 of the Business and Professions Code, and Section 846.5 of the Civil Code, each provide the right of entry to utilize boundary evidence and perform surveys, without undue delay, to any person authorized to practice land surveying. The right of entry is not contingent upon prior notice.
3. The Applicant shall furnish a Drainage and Grading Plan/Study to provide for property grading and drainage control, which shall also include prevention of sedimentation of damage to off-site properties. The Study/Plan shall be submitted to the Department of Public Works for review and approval. The applicant shall implement the approved plan. Employment of the appropriate Best Management Practices (BMP's) shall be included (Per Imperial County Code of Ordinances, Chapter 12.10.020 B).
4. Based from the information provided on the project documents, it is assumed that County roads will not be used for site access during or after construction activities have

An Equal Opportunity / Affirmative Action Employer

C:\Users\Guadalupe Vasquez\AppData\Local\Microsoft\Windows\INetCache\Content.Outlook\CRR10WL0\CUP20-0020 - Approved.doc

PC ORIGINAL PKG

been completed. In the event that County roads are required for site access, the Applicant shall consult with this Department in advance for review and approval.

5. Access to sites shall be completed from public roads. The Applicant shall obtain written approval from any private owners or other agencies for the use of any non-public roads to access the sites. A copy of such written approval shall be submitted to this Department prior to the approval of grading plans.
6. Any unimproved access roads/routes between public roads and access gates shall be improved for all-weather access. Such all-weather improvements shall be completed as recommended by a Geotechnical Engineer licensed to practice in the State of California.
7. Each site shall have, as a minimum, one (1) primary Class 2 Base aggregate material driveway and one (1) emergency access Class 2 Base aggregate material driveway.
8. Access to project sites during and after construction is expected to be completed through private unpaved roads or private property.
 - a. The Applicant shall mitigate generation of dust caused by construction traffic as per Rule 805 – Paved and Unpaved Roads of the Imperial County Air Pollution Control District.

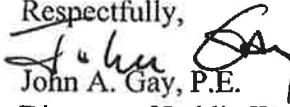
INFORMATIVE:

The following items are for informational purposes only. The Applicant is responsible to determine if the enclosed items affect the subject project.

- All solid and hazardous waste shall be disposed of in approved solid waste disposal sites in accordance with existing County, State and Federal regulations (Per Imperial County Code of Ordinances, Chapter 8.72).
- All on-site traffic areas shall be hard surfaced to provide all weather access for emergency vehicles. The surfacing shall meet the Department of Public Works and Fire/Office of Emergency Services (EOS) Standards as well as those of the Air Pollution Control District (APCD).
- The project may require a National Pollutant Discharge Elimination System (NPDES) permit and Notice of Intent (NOI) from the Regional Water Quality Control Board (RWQCB) prior to County approval of onsite grading plan (40 CFR 122.28).
- A Transportation Permit may be required from road agency(s) having jurisdiction over the haul route(s) for any hauls of heavy equipment and/or large vehicles which impose greater than legal loads on riding surfaces, including bridges. (Per Imperial County Code of Ordinances, Chapter 10.12 - OVERWEIGHT VEHICLES AND LOADS).

- Highline Canal Road is a private road. The Applicant may be required to mitigate dust generation on any portion of this road that may be used for construction and/or site access to comply with Imperial County Air Pollution Control District – RULE 805 PAVED AND UNPAVED ROADS (Adopted 11/08/2005; Revised 10/16/2012).
- Effective September 15, 2020, the State’s Mandatory Organic Waste Recycling Law (AB 1826 or Chapter 727, Statutes of 2014) decreased the threshold requiring all businesses and multi-dwelling facilities of 5 units or more generating two (2) cubic yards or more of solid waste per week to recycle their organic waste including landscape waste, wood waste, and food waste. Information about possible organics waste recycling services can be found at the CalRecycle site at:
<https://www.calrecycle.ca.gov/Recycle/Commercial/Organics/>
- As this project proceeds through the planning and the approval process, additional comments and/or requirements may apply as more information is received.

Should you have any questions, please do not hesitate to contact this office. Thank you for the opportunity to review and comment on this project.

Respectfully,

John A. Gay, P.E.
Director of Public Works



IID

A century of service.

www.iid.com

Since 1911

June 3, 2021

Ms. Diana Robinson
Planner III
Planning & Development Services Department
County of Imperial
801 Main Street
El Centro, CA 92243

RECEIVED
JUN 03 2021
IMPERIAL COUNTY
PLANNING & DEVELOPMENT SERVICES

SUBJECT: NOP of DEIR for the VEGA SES 4 Project; CUP Application No. 20-0020

Dear Ms. Robinson:

On May 6, 2021, the Imperial Irrigation District received from the Imperial County Planning & Development Services Department, a Notice of Preparation of Draft Environmental Impact Report for the VEGA SES 4 Solar Energy Project; Conditional Use Permit application no. 20-0020. The applicant, Apex Energy Solutions, LLC; proposes to develop a 100MW solar PV energy generation facility with a 100MW integrated battery storage on approximately 531.53 acres of land located between the U.S./Mexico border and the All-American Canal on the California side, 10 miles east of Calexico, CA (APNs 059-300-015-000, -300-017-000, -290-10-000). The project's electrical output would be conveyed through a proposed 92kV gen-tie line interconnection to the IID's 92kV "P" transmission line

The IID has reviewed the project information and found that the comments provided in the April 13, 2021 district letter (see attached letter) continue to apply.

Should you have any questions, please do not hesitate to contact me at 760-482-3609 or at dvargas@iid.com. Thank you for the opportunity to comment on this matter.

Respectfully,

Donald Vargas
Compliance Administrator II

Enrique B. Martinez – General Manager
Mike Pacheco – Manager, Water Dept.
Marilyn Del Bosque Gilbert – Manager, Energy Dept.
Constance Bergmark – Mgr. of Planning & Eng./Chief Elect. Engineer, Energy Dept.
Enrique De Leon – Asst. Mgr., Energy Dept., Distr., Planning, Eng. & Customer Service
Jamie Asbury – Assoc. General Counsel
Vance Taylor – Asst. General Counsel
Michael P. Kemp – Superintendent, Regulatory & Environmental Compliance
Laura Cervantes – Supervisor, Real Estate



IID

A century of service.

www.iid.com

Since 1911

April 13, 2021

Ms. Diana Robinson
Planner III
Planning & Development Services Department
County of Imperial
801 Main Street
El Centro, CA 92243

SUBJECT: Vega SES 4 Project; CUP Application No. 20-0020

Dear Ms. Robinson:

On April 5, 2021, the Imperial Irrigation District received from the Imperial County Planning & Development Services Department, a request for agency comments on Conditional Use Permit application no. 20-0020 for the Vega SES 4 Solar Energy Storage Project. The applicant, Apex Energy Solutions, LLC; proposes to develop a 100MW solar PV energy generation facility with a 100MW integrated battery storage on approximately 531.53 acres of land located between the U.S./Mexico border and the All-American Canal on the California side, 10 miles east of Calexico, CA (APNs 059-300-015-000, -300-017-000, -290-10-000). The project's electrical output would be conveyed through a proposed 92kV gen-tie line interconnection to the IID's 92kV "P" transmission line

The Imperial Irrigation District has reviewed the information and has the following comments.

1. If the project requires temporary construction or permanent electrical service at the distribution level, the applicant should be advised to contact Joel Lopez, IID Customer Project Development Planner, at (760) 482-3300 or e-mail Mr. Lopez at jflopez@iid.com to initiate the customer service application process. In addition to submitting a formal application (available for download at the district website <http://www.iid.com/home/showdocument?id=12923>), the applicant will be required submit a complete set of plans approved by the County of Imperial (in hardcopy and AutoCad formats) including site plan, plan & profile drawings, one-line diagrams, and electrical loads, panel size, voltage requirements, project schedule, and the estimated in-service date, in addition to the applicable fees, permits, easements and environmental compliance documentation pertaining to the provision of electrical service to the project. The applicant shall be responsible for all costs and mitigation measures related to providing electrical service to the project.

2. Distribution-rated electrical service is limited in the area. A circuit study may be required. Any improvements or mitigation identified in the circuit study to enable the provision of electrical service shall be the financial responsibility of the applicant.
3. To insure there are no impacts to IID facilities, applicant should submit project plans, including grading & drainage and fencing plans, to IID Water Department Engineering Services for review and comment prior to final project design and CUP approval. IID WDES can be contacted at (760) 339-9265 for further information on this matter.
4. The project may impact IID drains with project site runoff flows draining into IID drains. To mitigate impacts, the project may require a comprehensive IID hydraulic drainage system analysis. IID's hydraulic drainage system analysis includes an associated drain impact fee.
5. A construction storm water permit from the California Regional Water Quality Control Board is required before commencing construction and an industrial storm water permit from CRWQCB is required for the operation of the proposed facility. The project's Storm Water Pollution Prevention Plan and storm water permits from CRWQCB should be submitted to IID for review.
6. In order to obtain a water supply from IID for a non-agricultural project, the project proponent will be required to comply with all applicable IID policies and regulations and may be required to enter into a water supply agreement. Such policies and regulations require, among other things, that all potential environmental and water supply impacts of the project be adequately assessed, appropriate mitigation developed if warranted, including any necessary approval conditions adopted by the relevant land use and permitting agencies.
7. If IID implements a water allocation or apportionment program pursuant to the IID Equitable Distribution Plan, or any amending or superseding policy for the same or similar purposes, during all or any part of the term of said water supply agreement, IID shall have the right to apportion the project's water as an industrial water user. Information on how to obtain a water supply agreement can be found at the IID website <https://www.iid.com/water/municipal-industrial-and-commercial-customers> or by contacting Justina Gamboa-Arce, Water Resources Planner at (760) 339-9085 or jgamboarce@iid.com.
8. For information on procuring construction water, the applicant should contact IID South End Division at (760) 482-9800.

9. Any construction or operation on IID property or within its existing and proposed right of way or easements including but not limited to: surface improvements such as proposed new streets, driveways, parking lots, landscape; and all water, sewer, storm water, or any other above ground or underground utilities; will require an encroachment permit, or encroachment agreement (depending on the circumstances). A copy of the IID encroachment permit application and instructions for its completion are available at <https://www.iid.com/about-iid/department-directory/real-estate>. The IID Real Estate Section should be contacted at (760) 339-9239 for additional information regarding encroachment permits or agreements.
10. In addition to IID's recorded easements, IID claims, at a minimum, a prescriptive right of way to the toe of slope of all existing canals and drains. Where space is limited and depending upon the specifics of adjacent modifications, the IID may claim additional secondary easements/prescriptive rights of ways to ensure operation and maintenance of IID's facilities can be maintained and are not impacted and if impacted mitigated. Thus, IID should be consulted prior to the installation of any facilities adjacent to IID's facilities. Certain conditions may be placed on adjacent facilities to mitigate or avoid impacts to IID's facilities
11. The applicant may not use IID's canal or drain banks to access the project site. Any abandonment of easements or facilities shall be approved by IID based on systems (Irrigation, Drainage, Power, etc.) needs.
12. An IID encroachment permit is required to utilize existing surface-water drainpipe connections to drains and receive drainage service from the district. Surface-water drainpipe connections are to be modified in accordance with IID Water Department Standards.
13. The applicant should be advised to apply for and obtain two (2) encroachment permits for the proposed primary entrance, one from the U.S. Bureau of Reclamation and the second from IID. The applicant should not solely rely on the East Highline Canal check gate at the All-American Canal as the primary entrance to the project site. The IID Water Department reviews all encroachment applications on a case-by-case basis and the encroachment application will need to include detailed facility usage information at the time of applying for the encroachment permit. For further information on this matter, contact Hilda Romo, Senior Engineer, at (760) 339-9459 or at hmromo@iid.com.
14. Any new, relocated, modified or reconstructed IID facilities required for and by the project (which can include but is not limited to electrical utility substations, electrical transmission and distribution lines, water deliveries, canals, drains, etc.) need to be included as part of the project's CEQA and/or NEPA documentation,

Diana Robinson
April 13, 2021
Page 4

environmental impact analysis and mitigation. Failure to do so will result in postponement of any construction and/or modification of IID facilities until such time as the environmental documentation is amended and environmental impacts are fully analyzed. **Any and all mitigation necessary as a result of the construction, relocation and/or upgrade of IID facilities is the responsibility of the project proponent.**

Should you have any questions, please do not hesitate to contact me at 760-482-3609 or at dvargas@iid.com. Thank you for the opportunity to comment on this matter.

Respectfully,



Donald Vargas
Compliance Administrator II

Enrique B. Martinez – General Manager
Mike Pacheco – Manager, Water Dept.
Marilyn Del Bosque Gilbert – Manager, Energy Dept.
Constance Bergmark – Mgr. of Planning & Eng./Chief Elect. Engineer, Energy Dept.
Enrique De Leon – Asst. Mgr., Energy Dept., Distr., Planning, Eng. & Customer Service
Jamil Asbury – Assoc. General Counsel
Vance Taylor – Asst. General Counsel
Michael P. Kemp – Superintendent, Regulatory & Environmental Compliance
Laura Cervantes – Supervisor, Real Estate

PC ORIGINAL PKG

AIR POLLUTION CONTROL DISTRICT



June 4, 2021

Mr. Jim Minnick
Planning Director
801 Main Street
El Centro, CA 92243

RECEIVED

JUN 04 2021
IMPERIAL COUNTY
PLANNING & DEVELOPMENT SERVICES

SUBJECT: Initial Study 20-0029 and Notice of Preparation for a Draft Environmental Impact Report for Conditional Use Permit (CUP) 20-0020 for Vega 4 SES Solar Project by Apex Energy Solutions, LLC

Dear Mr. Minnick,

The Imperial County Air Pollution Control District (Air District) has reviewed Initial Study 20-0029 and the Notice of Preparation (NOP) for a Draft Environmental Impact Report (DEIR) for Conditional Use Permit (CUP) 20-0020 for the Vega 4 SES Solar Project. The proposed Project includes a 100 megawatt (MW) solar photovoltaic power generating facility and substation; a 200MW battery storage system; and a 92 kV intertie line. The Project would be located on 531 acres at 2849 East Highway 98 about 10 miles east of Calexico near the All American Canal next to the US-Mexican border, also described as Assessor's Parcel Numbers (APNs) 059-290-010-000, 059-300-015, and 059-300-017-000.

In previous comments dated April 6, 2021, the Air District outlined the expectations of a preliminary Air Quality Analysis that would be consistent with the Air District's California Environmental Quality Act (CEQA) Air Quality Handbook (ed. 2017). While the Air Quality and Greenhouse Gas Assessment ("AQGGA") addressed most elements of a comprehensive AQGGA, the Air District cannot concur with a Tier 1 finding based on inconsistencies in changes to the default settings of the California Emissions Estimator Model (CalEEMod) and misinterpretations of Air District rules and regulations.

In Section 2.3.2—Methodology, the statement "Project construction-generated air pollutant emissions were calculated using CalEEMod defaults..." is inconsistent with the notations in the CalEEMod output which show that the default for mobile percent road dust was changed from 50

to 90 and that the Construction default setting of 50 percent for paved roads was changed to 100 percent. Additionally, Table 2-6—Operational-Related Emissions gives “0” for PM₁₀ area emissions, while the CalEEMod output provides a different value for PM₁₀ Total Operational Emissions. As pointed out in previous comments, cumulative impacts are a major concern during operational phases of these projects, which is why an **Operational Dust Control Plan** must be part of the required mitigation measures.

The statement (pg. 15) that projects predicted to exceed Tier 1 thresholds require implementation of applicable ICAPCD standard mitigation measures to be considered less than significant is inconsistent with the Air District’s CEQA Air Quality Handbook. The Air District’s CEQA Handbook requires the use of standard mitigation measures for projects that fall below the level of significance. A subsequent misunderstanding of Air District rules is found in Section 2.3.3 regarding Rule 801—Construction and Earthmoving Activities. This rule goes beyond “reasonable precautions” and outlines specific steps that must be taken to reduce emissions of fugitive dust. Rule 801 is not a stand-alone rule, but is one of a collection of rules in Regulation VIII which together are designed to limit emissions of fugitive dust (PM₁₀) to 20% opacity.

The statement that the Project would not involve construction activities that would result in ozone (O₃) precursor emissions of ROG or NO_x is erroneous (pg. 21). The United States Environmental Protection Agency (USEPA) considers NO_x an ozone precursor.¹ As previously discussed, a **Construction Equipment List** will be required to identify NO_x emissions during the construction phase of the project. Please refer to the April 6, 2021 comments for details pertaining to the essential elements of such list.

Finally, the Air District recommends the use of the Mojave Desert Air Quality Management District’s Greenhouse Gas (GHG) significance thresholds rather than those of the South Coast Air Quality Management District. While climate may be similar, there is a noticeable difference in geography between the Riverside portion of the Salton Sea Air Basin and the rest of Imperial County. Thus, the GHG inventories for climate sectors such as transportation, energy and electric power for the MDAQMD are more representative of Imperial County.

¹ United States Environmental Protection Agency. Ground-level Ozone Basics. 2021 May 5. <https://www.epa.gov/ground-level-ozone-pollution/ground-level-ozone-basics>

The Air District looks forward to reviewing a revised Air Quality and Greenhouse Gas Assessment.

Air District rules and regulations can be found on our website at www.co.imperial.ca.us/AirPollution under the planning section. If any questions arise, please feel free to contact our office at (442) 265-1800.

Sincerely,



Curtis Blondell

APC Environmental Coordinator



Reviewed by,

Monjica N. Soucier

APC Division Manager



www.AgLandTrust.org
Location: 1263 Padre Drive | Salinas, CA
Mail Address: P.O. Box 1731 | Salinas, CA 93902
Tel.: 831.422.5868

Date: July 12, 2021 cc: Carlos Ortiz, Agriculture Commissioner
Imperial County, CA

To: Ramon Gonzalez, Business Development & Project Coordinator
ZGlobal

From: Sherwood Darington, Chief Executive Officer
Ag Land Trust

Subject: Vega SES Solar Energy Project
Agricultural Conservation Easement(s), Imperial County, CA

Dear Ramon,

Thank you for considering utilizing Ag Land Trust in your efforts to secure the conservation easement mitigation requirement for the solar energy project in Imperial County, CA.

The Conditional Use Permit (CUP) #17-0001 requires that the conservation easement conforms with the requirements of the Department of Conservation and the Department of Conservation requirement includes a forever in perpetuity timeframe.

If your project conforms with the Department of Conservation requirements and if we can be of further assistance, please reach out to us.

PC ORIGINAL PKG

July 21, 2021

Anika Larson
ZGlobal, Inc.
604 Sutter Street, Suite 250
Folsom, CA 95630

RE: Visual Impact Assessment Letter Report– Vega SES 4 Project

Dear Ms. Larson:

The purpose of this Visual Impact Assessment (VIA) letter report is to evaluate the potential visual impacts associated with the construction and implementation of the Vega SES 4 Solar Energy Storage Project located in Imperial County, California. This VIA includes an analysis and description of the existing visual setting and potential visual impacts. If the Project results in any adverse visual impacts, the purpose of the VIA is also to propose measures to minimize those impacts.

1.0 PROJECT DESCRIPTION, LOCATION, AND SETTING

The Project is located in south-central Imperial County between the California/Mexico border and the All-American Canal (Aqueduct). Figures 1 and 2 depict the Project location and vicinity (Attachment A).

Vega SES 4 is located on Imperial County Assessor's Parcel Numbers (APNs) 059-300-015-000 (approximately 301.73 acres), 059-300-017-000 (approximately 148.88 acres), and 059-290-010-000 (approximately 80.92 acres). All Project parcels are designated as "Agriculture" in the Imperial County General Plan and are zoned A-3-RE (Heavy Agriculture with a Renewable Energy Overlay).

Project Characteristics

Solar panels would use either thin film or crystalline solar photovoltaic (PV) technology modules mounted either on fixed frames or horizontal single-axis tracker (HSAT) systems. The fixed frame PV module arrays would be mounted on racks that would be supported by driven piles. The fixed-frame racks would be secured at a fixed tilt of 20 degrees to 30 degrees from horizontal facing a southerly direction. Current Project designs would have individual PV modules, mounted two high on a fixed frame, providing a two-foot ground clearance and resulting in the tops of the panels at approximately 7.5 feet above the ground. The fixed PV modules would be arranged in arrays spaced approximately 15 to 25 feet apart (pile-to-pile) to maximize performance and to allow access for panel cleaning (if necessary). These arrays would be separated from each other and the perimeter security fence by up to 30-foot wide interior roads. If HSAT technology is used, the PV modules would rotate around the north-south HSAT axis so that the PV modules would continue to face the sun as the sun moves across the sky throughout the day. The PV modules would reach their maximum height (up to nine (9) feet above the ground, depending on the final design) at both sunrise and sunset, when the HSAT is rotated to point the modules at the rising or setting sun. At noon, or when stowed during high winds, when the HSAT system is rotated so that the PV

modules are horizontal, the nominal height would be about six feet above the ground, depending on the final design. The individual PV systems would be arranged in large arrays by placing them in columns spaced approximately ten feet apart to maximize operational performance and to allow access for panel cleaning and maintenance. Current Project designs would have individual HSAT PV modules, each approximately two feet wide by four feet long (depending on the specific PV technology selected), mounted on a frame which is attached to an HSAT system. These HSAT arrays would be separated from each other and the perimeter security fence by up to 30-foot wide roads, consistent with County emergency access requirements.

Construction activities would primarily involve demolition and grubbing; grading at the Project site to establish access roads and pads for electrical equipment (inverters and step-up transformers); trenching for underground electrical collection lines; and the installation of solar equipment and security fencing. Stormwater management facilities would be constructed internally within the site and would consist of basins and infiltration areas. Dust generated during construction would be controlled by watering and, as necessary, the use of other dust suppression methods and materials accepted by the Imperial County Air Pollution Control District (ICAPCD) or the California Air Resources Board (CARB). A temporary, portable construction supply container would be located at the Project site at the beginning of construction and removed at the end of construction. Onsite parking would be provided for all construction workers.

Once construction is completed the Project would be remotely controlled. No employees would be based at the Project site. Primary security-related monitoring would be done remotely. Security personnel may conduct unscheduled security rounds and would be dispatched to the site in response to a fence breach or other alarm. Site maintenance workers may access the Project site periodically to clean the panels and maintain the equipment and Project area. The public would not have access to the facility. Access to the Project site would be infrequent and limited to authorized personnel.

Conceptual plans for the Vega SES4 project are provided in Attachment B.

2.0 VISUAL IMPACT ASSESSMENT METHODOLOGY

The following steps were taken in analyzing the visual impacts of the proposed Vega SES 4Solar and Battery Storage Project.

1. Describe the existing visual setting, including any sensitive viewer groups (i.e., baseline conditions);
2. Describe the visual appearance of the Project. Key viewpoints were not selected to represent the typical views from the public right-of-way because the nearest public right-of-way is located approximately 0.5 mile away;
3. Assess the visual changes that would be introduced by the Project and the viewer response based on defined attributes which are neither good nor bad. Change in visual character cannot be described as having good or bad attributes until compared with viewer responses to the change;
4. Determine the degree of visual impact;
5. Proposed methods to minimize adverse impacts

Evaluation of potential visual impacts resulting from implementation of the Proposed Project is based on the following criteria:

Change in Visual Quality. The difference in visual quality between the existing environmental setting and post-Project condition is considered visual quality change. Those changes are identified by studying site plans, which provide information on the various elements that will be removed from and incorporated into the current viewshed and the degree of change in the existing setting. The plans help to understand the potential changes in visual quality of the site after implementation of the Project. Physical changes are analyzed in relation to vividness, intactness, and unity of the proposed project conditions. Sensitivity of various viewer groups is evaluated to measure response to the visual quality changes.

Impacts to Visual Resources. Visual resources from both the natural and built environments can enhance the visual character and aesthetic quality of an area. The Project limits and vicinity were studied for visual resources. Visual resources can be associated with local events and history that represent and enhance the visual character of the local area. A project that substantially alters important visual resources can result in significant visual impacts. Mitigation is typically implemented to remove or minimize significant visual impacts.

Light, Glare, Shade, and Shadow. The existing light environment serves as a baseline to conduct light analysis and compare potential impacts caused by the introduction of the Proposed Project. Impacts relating to light, glare, shade, and shadow were examined during field observations and by the photographs to help establish light conditions during various times of the day and night and estimate the potential changes in the environment from Project implementation. New light sources and reduction or elimination of light could be considered impacts that could change the natural environmental setting of a project site. Impacts are evaluated based on how much existing conditions change, the degree of those changes, and the sensitivity of the affected environment.

Compatibility with Visual Policies. General Plans, Specific Plans, and other regulations or policies relating to visual resources and setting at the project site have been identified, reviewed, and used in the preparation of this analysis. Proposed visual changes that conflict with the adopted County guidelines could be considered a significant impact.

3.0 LOCAL VISUAL RESOURCE POLICIES

County of Imperial General Plan

Circulation and Scenic Highways Element

The Imperial County General Plan Circulation and Scenic Highways Element provides information about the transportation needs of the County and the various modes to meet these needs and provides for the movement of goods and people, including pedestrian, bicycles, transit, train, air and automobile. This Element is also intended to provide a plan to accommodate a pattern of concentrated and coordinated

growth and to provide a means of protecting and enhancing scenic resources within both rural and urban scenic highway corridors.

The potential designation of Scenic Highway has been placed on specific roadways in the County and may be added to others in the future. This designation is intended to protect and enhance the County's scenic aesthetic resources which are visible from major County and State routes. As identified in the Circulation and Scenic Highways Element, four State routes within the County have the potential for designation as Scenic Highways:

- **Interstate 8 (I-8):** The initial segment for future Scenic Highway Designation status lies between the San Diego County line and its junction with State Route 98 (SR-98). This segment known as Mountain Springs Grade has a long, rapid elevation change, remarkable rock and boulder scenery, and plant life variations.
- **State Route 78 (SR-78):** The portion of SR-78 from the junction with State Route 86 (SR-86) to the San Diego County line is eligible for future Scenic Highway Designation. The area is considered scenic because of its desert characteristics and view of Salton Sea.
- **State Route 111 (SR-111):** SR-111 travels along the northeast shore of the Salton Sea and is eligible for future Scenic Highway Designation from Bombay Beach to the County line. The drive along this body of water is a study in primitive beauty and an interesting and startling anomaly. The contrast between the flat, wide Salton Sea with its sandy beach and the rugged rise of the Chocolate Mountains has many variations. The panoramic view of the opposite (southwest) shore and its backdrop of mountains is also a sight of pre-historic beauty.
- **Borrego-Salton Seaway:** County Highway S-22 is also known as the Borrego-Salton Seaway. It begins in Salton City and ends at the community of Borrego Springs in San Diego County. Along its route, is Clay Point, located a mile and half west of SR-86, which is a formation ring above a flat desert shore which shows the bed of pre-Columbian Lake Cahuilla. Three and a half miles farther west, the Anza Verde Wash parallels the Borrego-Salton Seaway with uniquely scenic desert landforms and vegetation.

The Circulation and Scenic Highways Elements contains the following objectives for the preservation of environmental and scenic amenities of the area along potential Scenic Highways.

- Objective 4.1 Establish various systems of scenic recreational travel utilizing multiple transportation modes.
- Objective 4.2 Preserve, enhance, and protect Imperial County's scenic resources by the removal of illicit billboards from scenic areas and restrictions on new off-site sign construction visible from designated scenic highways.
- Objective 4.3 Protect areas of outstanding scenic beauty along any scenic highways and protect the aesthetics of those areas.
- Objective 4.4 Acquire scenic easements from private owners when required.
- Objective 4.5 Develop standards for aesthetically valuable sites. Design review may be required so that structures, facilities, and activities are properly merged with the surrounding environment.

Conservation and Open Space Element

The Imperial County General Plan Conservation and Open Space Element is a conservation guide for the protection of regional aesthetics. This Element identifies goals and policies to ensure the managed use of environmental resources to prevent limiting the range of resources available to future generations. The Conservation and Open Space Element identifies scenic visual resources within the County which include the deserts, sand dunes, mountains, and the Salton Sea.

Desert areas include the Yuha Desert, West Mesa, lower Borrego Valley, East Mesa, and Pilot Knob Mesa. Within the desert areas, there are unique geologic features which add scenic value to the natural landscape and desert vegetation which results in springtime blooms of desert flowers in the springtime. The Algodones Dunes are the largest sand dunes in California covering approximately 160 square miles and are a well-known landmark to County residents and highway travelers. These dunes are a significant visual resource due to their unique scenic qualities, historic features, and prominent visibility to a large number of viewers.

As described in this Element, scenic mountains within the County include the eastern foothills of the Peninsular Range along the County's southwest side consisting of the In-Ko-Pah or Jacumba Mountains, Coyote Mountains, and Fish Creek Mountains. East of this area is Mount Signal located along the international border on the eastern edge of the Yuha Desert, west of Calexico. The southeast foothills of the San Rosa-San Jacinto Mountain are a prominent feature from SR-86. The Superstition Mountains and Superstition Hills, located in West Mesa southeast of the lower Borrego Valley and west of Westmorland and Brawley, are visible from I-8 west of El Centro and from SR-86 between El Centro and the Salton Sea. In the northeastern part of the County, the Chocolate Mountains stretch northwest by southeast between Riverside County and the Colorado River. Portions of these mountain areas are designated by the Bureau of Land Management (BLM) as Wilderness Areas, part of the National Wilderness Preservation System. The intention of this designation is to secure natural areas for the public purposes of recreation, scenic, scientific, educational, conservation, and historical use.

The Salton Sea is located in the northwestern portion of the County and encompasses approximately 376 square miles. This body of water has been sustained by agricultural drainage from the Imperial, Coachella, and Mexicali valleys, rainfall, storm runoff from surrounding mountains, and groundwater inflow. The Salton Sea provides migrating and winter habitat for waterfowl and other birds and is a unique visual resource because of its size, location in a desert environmental, and its value for wildlife.

Anza-Borrego Desert State Park, located on the eastern side of San Diego County with portions extending into Imperial Count, features washes, wildflowers, palm groves, cacti, sweeping vistas, and hiking trails.

The Conservation and Open Space Element also identifies scenic vista points which include the Osborne Overlook and Juan Bautista de Anza Overlook. The Osborne Overlook offers scenic views of the Imperial Sand Dunes Recreational Area, North Algodones Dunes Wilderness, and surrounding area while the Juan Bautista de Anza Overlook provides a view of the Yuha Basin and surrounding landscape.

The Conservation and Open Space Element contains the following objectives for the preservation of environmental and scenic amenities of the area along potential Scenic Highways (County of Imperial 2016).

Objective 5.1 Encourage the conservation and enhancement of the natural beauty of the desert and mountain landscape.

Objective 5.2 Utilize the Code Enforcement process to eliminate visually dilapidated buildings that impact the visual character of rural communities.

4.0 BASELINE VISUAL CONDITIONS

A view is defined by the topography, development, activity, and vegetation. The Project area was observed and mapped to identify existing visual resources in the area and viewer groups. The Project area was photodocumented during a visual field survey in September 2020 to record existing visual conditions in the Project vicinity and surrounding area. Land uses and topography were assessed to characterize the physical environment and establish the existing visual setting as described below.

Topography

Topography is relatively flat with elevations ranging between 11 meters (38 feet) and 18 meters (60 feet) above mean sea level. Adjacent land uses include agricultural and ranch land to the north and west, the U.S./Mexico border to the south, and undeveloped land to the east. The All-American Canal travels northeast to southwest, north of the Project site.

Land Use

Surrounding lands are designated as "Agriculture" by the Imperial County General Plan and are zoned A-3-RE (Heavy Agriculture with a Renewable Energy Overlay). Pursuant to Section 91703.02 (CONDITIONAL USE PERMITS), Renewable Energy Projects must be located within the Renewable Energy Overlay Zone and may be permitted only through the issuance of a Conditional Use Permit (CUP) as approved by the Approving Authority unless otherwise allowed by applicable law.

Vegetation

The majority of the Project site consists of creosote bush – white bursage scrub (disturbed), disturbed lands, and tamarisk thickets. Small portions of the Project site along the eastern perimeter and centrally within the site contain areas of creosote bush scrub. The remainder of the Project site on the western end consists of alkali weed – salt grass playas and sinks and arrow weed thickets (ECORP 2020).

Historic Resources

A records search for historic resources was conducted in September 2020 at the South Coastal Information Center (SCIC) at San Diego State University. The records search included a review of all recorded historic and prehistoric archaeological sites within a one-mile radius of the Project area, as well as a review of known cultural resource surveys and excavation report. Six previously recorded resources

were located within one mile of the Project site and one cultural resource was recorded within the Project site. Sixteen newly identified resources are located within the Project site and with the presence of one previously recorded resource, there are a total of 17 cultural resources present onsite. Seven of these cultural resources are located in the western portion of the Project site and will be avoided by the Project. (ECORP 2021). The remaining ten resources within the Project site that cannot be avoided by implementation of the Project include five sites (three historic period and two pre-contact) and five isolates. Subsurface testing and archival research determined that the five sites within the Project site are not eligible for the National Register of Historic Places (NRHP). The five isolates within the Project site were also evaluated and found not eligible for the NRHP and CRHR.

5.0 VISUAL CHANGE AND VISUAL IMPACT EVALUATION

Evaluation of potential visual impacts resulting from implementation of the proposed Vega SES 4 Project is based on the following criteria:

- **Change in Visual Quality.** The difference in visual quality between the existing environmental setting and post-Project condition is considered visual quality change. Those changes are identified by studying engineering plans, which provide information on the various elements that will be replaced and/or reconstruction into the current viewshed and the degree of change in the existing setting.
- **Impacts to Visual Resources.** Visual resources from both the natural and built environments can enhance the visual character and aesthetic quality of an area. The Project limits and vicinity were studied for visual resources. Visual resources can be associated with local events and history that represent and enhance the visual character of the local area. A project that substantially alters important visual resources can result in adverse visual impacts. Mitigation is typically implemented to remove or minimize adverse visual impacts.
- **Light, Glare, Shade, and Shadow.** The existing light environment serves as a baseline to conduct light analysis and compare potential impacts caused by introduction of one of the alternatives. Impacts relating to light, glare, shade, and shadow were examined during field observations and by the photographs to help establish light conditions during various times of the day and night and estimate the potential changes in the environment from project implementation. New light sources and reduction or elimination of light could be considered impacts that could change the natural environmental setting of a project site. Impacts are evaluated based on how much the existing conditions change, the degree of those changes, and the sensitivity of the affected environment.
- **Compatibility with Visual Policies.** General Plans, Specific Plans, and other regulations or policies relating to visual resources and setting at the project site have been identified, reviewed, and used in preparation of this assessment. Proposed visual changes that conflict with the adopted agency guidelines could be considered an adverse impact.

Available public right of way in the vicinity of the Project site includes CA State Route (SR) 98 and Vencil Road. Visibility of the site from the public right of way is obstructed from CA State Route 98 by a berm. Visibility of the project site from Vencil Road is limited due to a distance of approximately 0.5 mile. No key observation points are proposed for this analysis. Surrounding property is privately owned and viewers

would be limited to property owners, employees servicing/maintaining Imperial Irrigation District (IID) facilities (e.g., the canal), and border patrol personnel.

The overall character and experience for the viewer would change substantially with implementation of the Project. The main physical change that would occur is the complete removal of vegetation and grading of the Project site to accommodate the construction of solar apparatus and security fencing. Other facilities proposed such as roads, pads, underground utilities, and stormwater facilities would not be readily visible as these facilities would be at or below grade. There are no scenic resources located in the Project vicinity, no scenic vista points are identified in the County General Plan, and none of the roadways in the project vicinity are designated scenic highways or roadways.

The proposed PV module frames when installed on pads would be approximately 7.5 feet in height and the proposed security fencing would be approximately 6 feet in height. Currently, the existing vegetation on the project site consist of large dense bushes and trees; however, there are no existing obstructions of identified scenic resources as none are located in the Project vicinity and visible from surrounding areas.

Implementation of the proposed project would change the natural conditions of the site to a solar energy generation and battery storage facility. Onsite vegetation would be completely removed, and the site would be graded to accommodate the installation of the PV module frames in arrays. The Imperial County General Plan has designated the Project site as "Agriculture" and is zoned A-3-RE (Heavy Agriculture with a Renewable Energy Overlay). Agricultural uses within the Project are fallow and have not been actively used for agriculture for many years. Renewable energy projects must be located within the Renewable Energy Overlay Zone and may be permitted only through the issuance of a Conditional Use Permit (CUP). With a CUP, the Project would be consistent with the intended use of the land. Although Project implementation would result in the conversion of a naturally vegetated area with energy-related facilities, agricultural vegetated areas are not considered to be scenic resources by the County of Imperial.

Construction Impacts

Construction of the Proposed Project would result in temporary visual changes due to construction activities. Potential short-term construction impacts would result from the proposed Project through the presence of construction equipment and materials. Upon completion of construction, equipment and construction materials would no longer be present.

Light, Glare, Shade, and Shadow

Minimal lighting would be required for operations and would be limited to safety and security functions. All lighting will be directed downward and shielded to focus illumination on the desired areas only and to minimize light trespass in accordance with applicable County requirements. If additional lighting should be required for nighttime maintenance, portable lighting equipment would be used. The Project is not anticipated to create a new source of substantial light which would adversely affect nighttime views in the Project area.

The Project would involve the installation of PV solar arrays which have low reflectivity. Solar PV modules are specifically designed to reduce reflection as any reflected light cannot be converted into energy. Research has shown that reflectivity from PV panels are similar to reflections from water (National Renewable Energy Laboratory 2020). Therefore, the PV panels would not create a significant source of glare during sunlight hours. The Project would not use other reflective materials such as fiberglass, aluminum or vinyl/plastic siding, galvanized products, and brightly painted steel roofs that have the potential to create on- and off-site glare.

Shade and shadow effects would be introduced within the Project site due to the placement of PV modules in arrays. However, due to the height of the proposed apparatus at 7.5 feet and the perimeter fencing at 6 feet, the effects of shade and shadow would not encroach into areas offsite for extended periods of time that would result in significant shade and/or shadow impacts.

Scenic Highways

There are no designated Caltrans scenic highways in the vicinity of the Proposed Project. None of the scenic highways identified in the County's General Plan Circulation and Scenic Highways Element are located in the Project vicinity. Interstate 8 is located over 5 miles away to the north. There would be no impact to scenic resources within a State or locally designated scenic highway.

Historic Resources

As previously identified, sixteen newly identified resources are located within the Project site and with the presence of one previously recorded resource, there are a total of 17 cultural resources present onsite. The remaining ten resources within the Project site that cannot be avoided by implementation of the Project include five sites (three historic period and two pre-contact) and five isolates. Subsurface testing and archival research determined that the five sites within the Project site are not eligible for the NRHP. The five isolates within the Project site were also evaluated and found not eligible for the NRHP and CRHR. Further none of the cultural resources identified within the Project site are visible from public vantage points, there would be no visual impact to historic resources.

Visual Resource Policies

Scenic features, vistas, or landforms identified by the County of Imperial would not be significantly affected by construction and implementation of the Project. The Proposed Project would not conflict with specific policies identified in the Circulation and Scenic Highways Element or Open Space and Conservation Element of the County's General Plan. No impacts associated with incompatibility with visual resource policies would occur under the Proposed Project.

Summary of Impacts

During the construction phase, the presence of construction equipment and materials would not have a permanent, long-term impact on the visual environment. Upon completion of the Project, areas that were

cleared for construction staging would be converted to a new energy generating and storage facilities or returned to their existing condition.

No obstruction of existing scenic resources would occur with Project implementation as none existing in the Project vicinity.

Minimal lighting would be required for operations and would be limited to safety and security functions and would adhere to County lighting requirements. The Project is not anticipated to create a new source of substantial light which would adversely affect nighttime views in the Project area. Shade and shadow effects would not be a significant impact to adjacent properties due to the height of the proposed apparatus and security fencing.

No impacts to NRHP- or CRHR-eligible historic resources would occur with Project implementation.

The Project would be consistent with the County General Plan. No impacts associated with incompatibility with visual resource policies would occur under the Proposed Projects.

Sincerely,



Senior Environmental Planner
ECORP Consulting, Inc.

Attachments

Attachment A: Figures

Attachment B: Conceptual Plans



REFERENCES

County of Imperial. 2008. *County of Imperial General Plan Circulation and Scenic Highways Element*. January

_____. 2016. *County of Imperial General Plan Circulation and Scenic Highways Element*. March.

_____. 2016. *County of Imperial General Plan Conservation and Open Space Element*. March.

ECORP. 2020. *Biological Technical Report Vega SES 4 Solar Projects*. November

_____. 2020. *Cultural Resources Inventory Vega SES 4 Solar Energy Project*. November

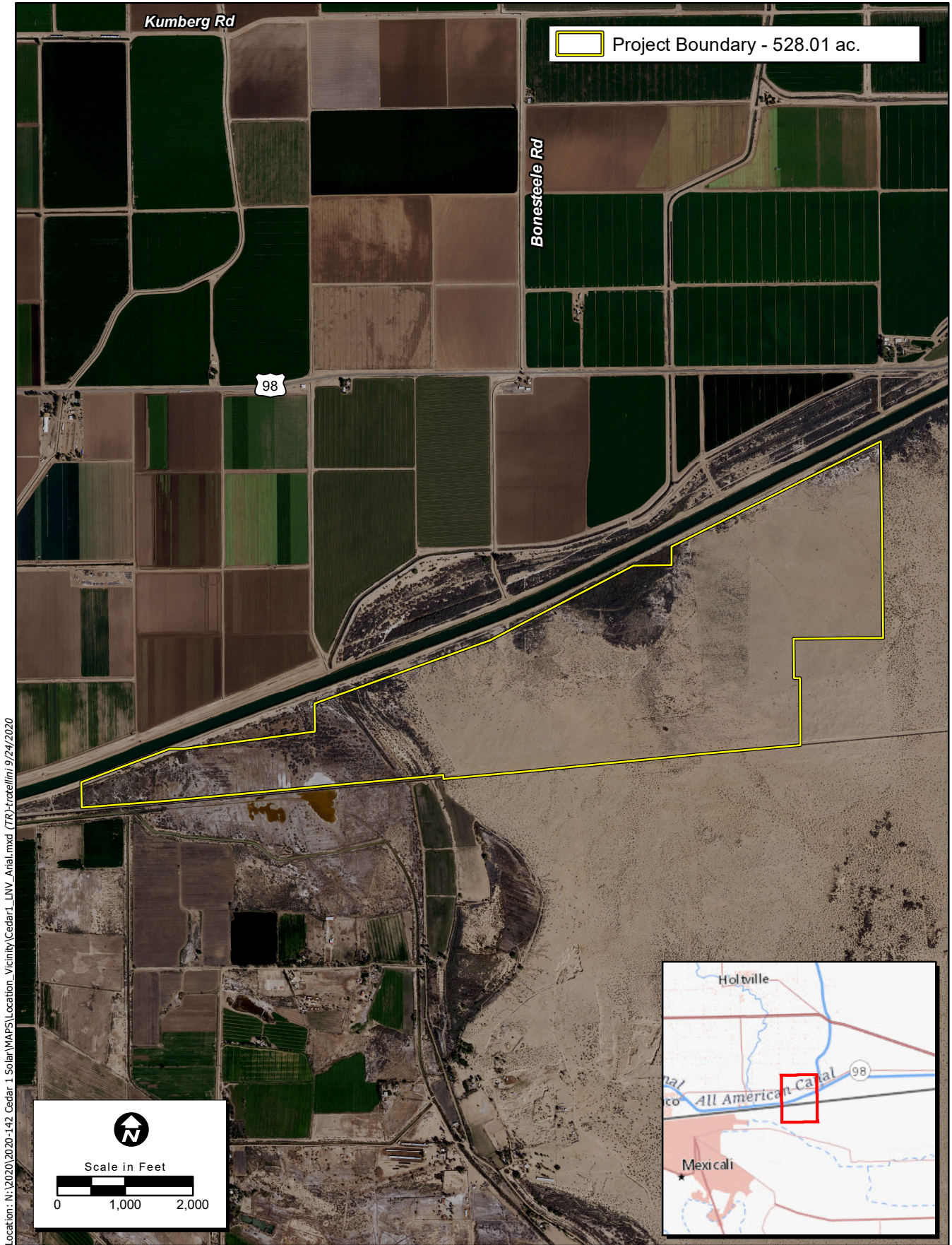
_____. 2021. *Cultural Resources Inventory, Testing, and Evaluation Report Vega SES 4 Solar Energy Project*. January

National Renewable Energy Laboratory. 2020. *Research and Analysis Demonstrate the Lack of Impacts of Glare from Photovoltaic Modules*. Website: <https://www.nrel.gov/state-local-tribal/blog/posts/research-and-analysis-demonstrate-the-lack-of-impacts-of-glare-from-photovoltaic-modules.html>, Accessed March 25, 2021.

LIST OF ATTACHMENTS

Attachment A – Figures

Attachment B – Conceptual Plans

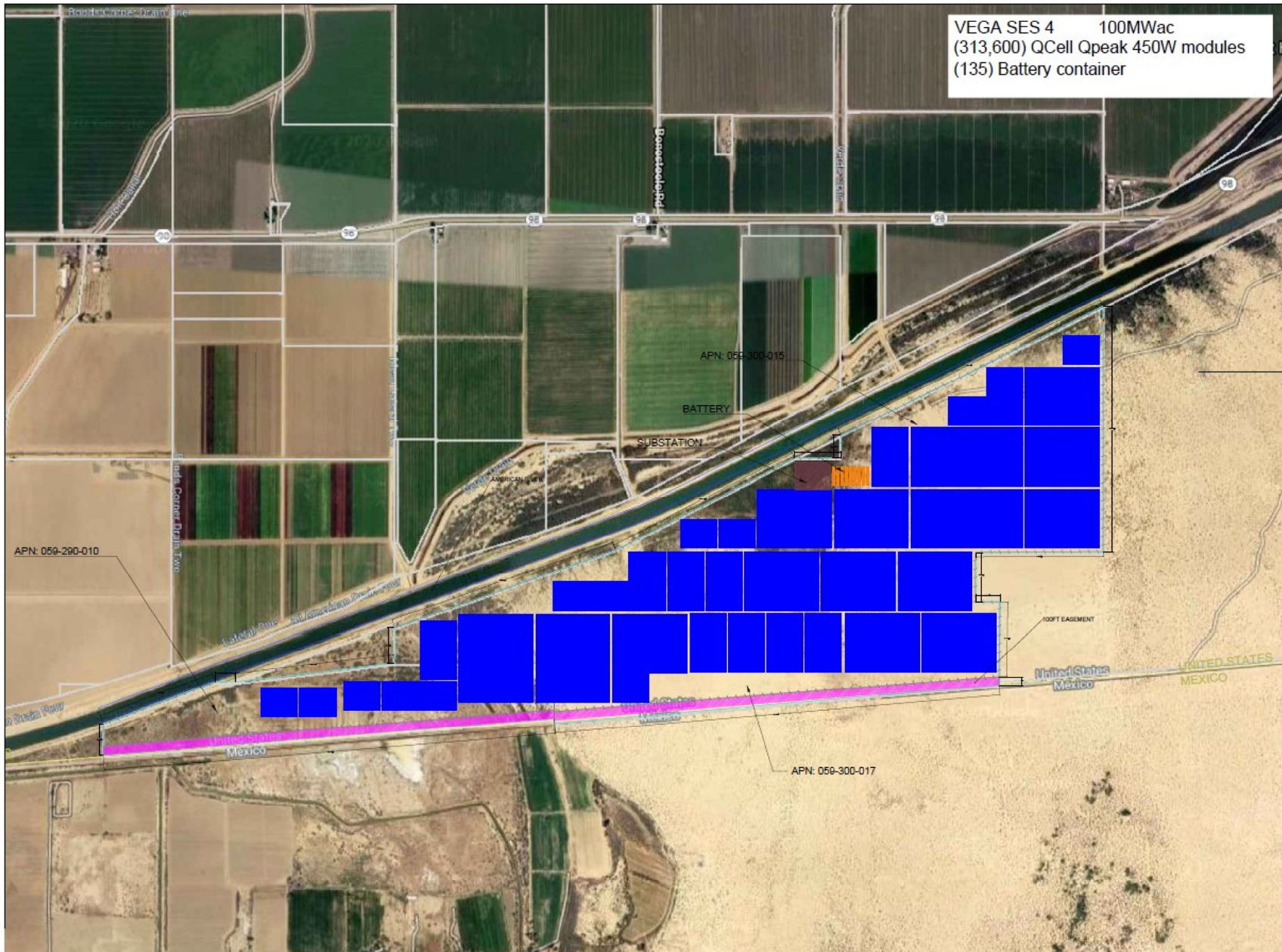


Location: N:\2020\2020-142_Cedar_1_Solar\WAPS\Location_Vicinity\Cedar1_LINV_Arial.mxd (TR)-truelin\9/24/2020

Map Date: 9/24/2020
 Service Layer Credits:
 Photo Source: NAIP (2018)

Figure 1. Project Location and Vicinity

2020-142 Vega SES 4



VEGA SES 4 100MWac
 (313,600) QCell Qpeak 450W modules
 (135) Battery container

VEGA SES 4

CONFIDENTIAL DOCUMENTS
 THE INFORMATION SHOWN ON THIS DRAWING IS STRICTLY CONFIDENTIAL AND IS SUPPLIED WITH THE UNDERSTANDING THAT IT WILL BE HELD CONFIDENTIAL AND NOT DISCLOSED TO THIRD PARTIES WITHOUT THE WRITTEN CONSENT OF SOLARIAL, INC.

REV.	BY	DESCRIPTION	DATE	APPROV.
0	RD	PRELIMINARY	08/17/20	JA

Scale to Contain 24"x36" Plot
 1 Inch

Apex SOLUTIONS
 604 SLUTTER ST, STE 250
 FOLSOM, CA 95630
 Phone : 916.985.9461
 Fax: 916.985.9467

"THESE DRAWINGS AND SPECIFICATIONS HAVE BEEN PREPARED BY SOLARIAL, INC. FOR THEIR EXCLUSIVE USE IN ACCORDANCE WITH SEC. 4937.3 OF THE 2015 PROFESSIONAL ENGINEERING ACT OF THE STATE OF CALIFORNIA"

SHEET TITLE:	
SITE PLAN	
DRAWN BY:	RD
CHECKED:	JA
SCALE:	1/8" = 1'-0"
JOB NO:	C-000
DATE:	1
REV NO:	1

**Air Quality and Greenhouse Gas Emissions
Assessment
for the
VEGA SES 4 Solar Energy Project**

County of Imperial, California

Prepared For:

ZGlobal/APEX Energy Solutions
750 W. Main Street
El Centro, CA 92243

Prepared By:



ECORP Consulting, Inc.
ENVIRONMENTAL CONSULTANTS

2525 Warren Drive
Rocklin, California 95677

October 2022

CONTENTS

1.0	INTRODUCTION	1-4
1.1	Project Overview.....	1-4
1.2	Project Location.....	1-4
2.0	AIR QUALITY	2-1
2.1	Air Quality Setting.....	2-1
2.1.1	Salton Sea Air Basin.....	2-1
2.1.2	Criteria Air Pollutants.....	2-2
2.1.3	Toxic Air Contaminants.....	2-5
2.1.4	Ambient Air Quality.....	2-5
2.1.5	Sensitive Receptors.....	2-7
2.2	Regulatory Framework.....	2-7
2.2.1	Federal.....	2-7
2.2.2	State.....	2-8
2.2.3	Local.....	2-10
2.3	Air Quality Emissions Impact Assessment.....	2-11
2.3.1	Thresholds of Significance.....	2-11
2.3.2	Methodology.....	2-12
2.3.3	Impact Analysis.....	2-13
3.0	GREENHOUSE GAS EMISSIONS.....	3-1
3.1	Greenhouse Gas Setting.....	3-1
3.1.1	Sources of Greenhouse Gas Emissions.....	3-2
3.2	Regulatory Framework.....	3-3
3.2.1	State.....	3-3
3.3	Greenhouse Gas Emissions Impact Assessment.....	3-4
3.3.1	Thresholds of Significance.....	3-4
3.3.2	Methodology.....	3-6
3.3.3	Impact Analysis.....	3-6
4.0	REFERENCES.....	4-1

LIST OF TABLES

Table 2-1.	Criteria Air Pollutants- Summary of Common Sources and Effects.....	2-3
Table 2-2.	Summary of Ambient Air Quality Data.....	2-6
Table 2-3.	Attainment Status of Criteria Pollutants in the Imperial County Portion of the SSAB.....	2-7

Table 2-4. ICAPCD Significance Thresholds – Pounds per Day.....2-12

Table 2-5. Unmitigated Project Construction-Generated Emissions2-14

Table 2-6. Mitigated Project Construction-Generated Emissions.....2-17

Table 2-7. Operational-Related Emissions (Regional Significance Analysis)2-18

Table 2-8. Proposed Project Displaced Criteria Pollutant Emissions (Tons)2-20

Table 3-1. Greenhouse Gases 3-2

Table 3-2. Construction-Related Greenhouse Gas Emissions..... 3-7

Table 3-3. Operational-Related Greenhouse Gas Emissions..... 3-8

Table 3-4. Life-Cycle Greenhouse Gas Emissions for Various Types of Energy Generators 3-9

Table 3-5. Proposed Project Displaced GHG Emissions (Metric Tons).....3-10

LIST OF ATTACHMENTS

- Attachment A – CalEEMod Output Files Criteria Air Pollutants
- Attachment B – Renewable Energy Emissions Displacement
- Attachment C – CalEEMod Output Files Greenhouse Gas Emissions

LIST OF ACRONYMS AND ABBREVIATIONS

°F	Degrees Fahrenheit
µg/m ³	Micrograms per cubic meter; ppm = parts per million
1992 CO Plan	1992 Federal Attainment Plan for Carbon Monoxide
AB	Assembly Bill
AC	Alternating Current
AQMD	Air Quality Management District
BESS	Battery Electric Storage System
CAA	Clean Air Act
CAAQS	California Ambient Air Quality Standards
CalEEMod	California Emissions Estimator Model
Caltrans	California Department of Transportation
CAPCOA	California Air Pollution Control Officers Association
CARB	California Air Resources Board
CCAA	California Clean Air Act
CCR	California Code of Regulations
CEQA	California Environmental Quality Act
CH ₄	Methane
CO ₂	Carbon dioxide
CO ₂ e	Carbon dioxide equivalent
County	Imperial County
CUP	Conditional Use Permit
DPM	Diesel particulate matter

LIST OF ACRONYMS AND ABBREVIATIONS

EO	Executive Order
GHG	Greenhouse gas
GWP	Global warming potential
ICAPCD	Imperial County Air Pollution Control District
IID	Imperial Irrigation District
IPCC	Intergovernmental Panel on Climate Change
kV	Kilovolt
MDAQMD	Mojave Desert Air Quality Management District
MW	Megawatt
MWAC	Megawatt Alternating Current
N ₂ O	Nitrous oxide
NAAQS	National Ambient Air Quality Standards
NO ₂	Nitrogen dioxide
NO _x	Nitric oxides
O ₃	Ozone
PM	Particulate matter
PM ₁₀	Coarse particulate matter
PM _{2.5}	Fine particulate matter
POI	point of interconnection
ppb	Parts per billion
Project	VEGA SES 4 Solar Energy Project
PV	Photovoltaic
ROGs	Reactive organic gases
RE	Renewable Energy
SB	Senate Bill
SCAQMD	South Coast Air Quality Management
SIP	State Implementation Plan
SO ₂	Sulfur dioxide
SO _x	Sulfur oxides
SR	State Route
SRA	Source receptor area
SSAB	Salton Sea Air Basin
TACs	Toxic air contaminants
USEPA	U.S. Environmental Protection Agency
VOC	Volatile organic compound
VMT	Vehicle Miles Traveled

1.0 INTRODUCTION

This report documents the results of an assessment of both air quality and greenhouse gas (GHG) emissions completed for the VEGA SES 4 Solar Energy Project (Project), which includes the construction of a 100-megawatt (MW) alternating current (AC) solar field on approximately 451 acres of vacant land on two parcels in Imperial County, California (APN 059-300-015, 301.73 acres; APN 059-300-017, 148.88 acres). This assessment was prepared using methodologies and assumptions recommended in the rules and regulations promulgated by the Imperial County Air Pollution Control District (ICAPCD). Regional and local existing conditions are presented, along with pertinent emissions standards and regulations.

1.1 Project Location

The Project Site is located on approximately 451 acres of privately-owned land in the southernmost portion of Imperial County, California (see Figures 1-1 and 1-2). The Project Site is between the U.S./Mexico international border and the All-American Canal, on the California side. It is approximately 10 miles east of the City of Calexico in Sections 10, 11, 14, 15, and 16 within Township 17 South, and Range 16 East of the San Bernardino Base and Meridian of the Bonds Corner topographic 7.5-minute quadrangle. The irregular shaped Project Site is bound by undeveloped land, portions of which have been disturbed associated with previous agricultural-related activities to the west and east, the All-American Canal running southwest on the northern border of the Project Site, and the U.S./Mexico international border to the south. The Project Site is currently characterized by flat and undeveloped land, portions of which have been disturbed associated with previous agricultural-related activities.

In 2016, the County adopted the Imperial County Renewable Energy and Transmission Element, which includes an RE Zone (RE Overlay Map). This General Plan element was created as part of the California Energy Commission Renewable Energy Grant Program to amend and update the County's General Plan to facilitate future development of renewable energy projects. The County Land Use Ordinance, Division 17, includes the RE Overlay Zone, which authorizes the development and operation of renewable energy projects with an approved conditional use permit (CUP). The RE Overlay Zone is concentrated in areas determined to be the most suitable for the development of renewable energy facilities while minimizing the impact on other established uses. As shown on Figure 1-1, the Project Site is located within the RE Overlay Zone. Therefore, no General Plan Amendment or Rezone would be required to implement the Proposed Project.

1.2 Project Overview

The Proposed Project consists of three primary components: 1) solar energy generation equipment and associated facilities including a substation and access roads (herein referred to as "solar energy facility"); 2) battery energy storage system (BESS); 3) generator intertie (gen-tie) that would connect the proposed onsite substation to the point of interconnection at the existing Imperial Irrigation District (IID) 92 kilovolt "P" line. The first component, a 100 MW AC photovoltaic (PV) solar energy facility, would span the majority of the Project Site. The BESS component would be located within the northeastern portion of the solar energy facility site and span two acres (APN 059-300-015). The electrical energy produced by the Project would be conducted through the Project's interconnection facilities to the proposed 92 kilovolt (kV) gen-tie line and

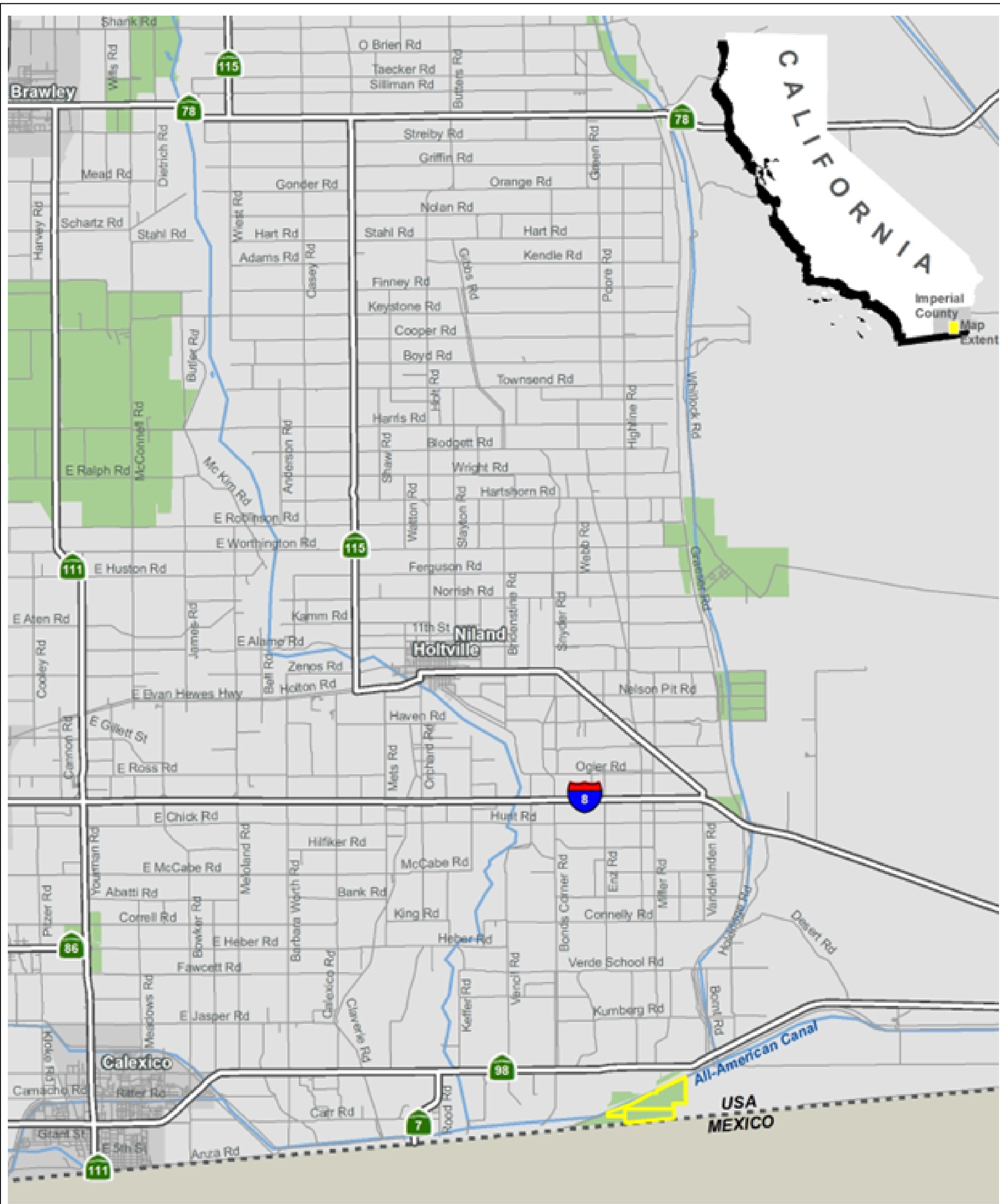
delivered to the existing IID approved point of interconnection (POI) on the 92 kV "P" Line located immediately north of the Project Site and the All-American Canal. Once fully constructed, the Project Site would be developed with a ground mounted PV solar power generating system, supporting structures, on-site substation spanning two acres, BESS, interconnection facilities, and internal access roads. The Project would employ the use of PV power systems to convert solar energy into electricity using non-reflective technology.

Construction activities would primarily involve demolition and grubbing, grading of the Project Site to establish access roads and pads for electrical equipment, trenching for underground electrical collection lines, and the installation of solar equipment and security fencing. Construction is estimated to take 12-18 months and would begin in late 2022 or 2023. The number of on-site construction workers for the solar facility is not expected to exceed 150 workers at any time. The number of on-site construction workers for the BESS and substation is not expected to exceed 100 workers at any one time.

All heavy-duty construction vehicles would cross the All-American Canal at Gordon Wells Road located approximately 20 miles east of the Project Site, then travel west along an existing dirt road paralleling the U.S./Mexico Border. Access for heavy construction vehicles to and from the Project Site requires crossing the All-American Canal, via two existing bridges, located along Gordon Wells Road. Gordon Wells Road has an interchange with Interstate 8. The bridges over the canal were constructed in 2009 and are rated as open with no restrictions and have a "Good" condition rating. An estimated two trucks would arrive at the Project Site each day during the first few weeks of construction of the solar facility. Construction workers would utilize an existing driveway off State Route 98 and then park their vehicles in a designated staging/parking area, approximately 3.5 acres in size, north of the All-American Canal. The staging/parking area is proposed to be improved to facilitate access and minimize parking conflicts. Construction workers would then walk across the All-American Canal at an existing crossing east of the Project Site. No vehicles or construction vehicles are allowed to travel across this existing crossing. Designated shuttles would pick up the construction workers at the south end of the crossing, and then travel west for approximately one mile along an existing dirt road to the Project Site. According to the Project Proponent, dust generated during construction would be controlled by watering and, as necessary, the use of other dust suppression methods and materials accepted by the ICAPCD.

Once construction is completed, the facility would be remotely operated, controlled and monitored and with no requirement for daily on-site employees. Security personnel may conduct unscheduled security rounds and would be dispatched to the Project Site in response to a fence breach or other alarm. Up to two to three people would be contracted (part-time) to perform all routine and emergency operational and maintenance activities. Such activities include inspections, equipment servicing, site and landscape clearing, and periodic washing of the PV modules if needed (up to two times per year) to maintain power generation efficiency. The amount of water needed for solar panel washing is estimated at approximately 5 acre-feet per washing, with up to two washings per year, or a total of up to 10 acre-feet per year. Vegetation growing on the solar energy facility site would periodically (approximately every 3 months) be removed manually and/or treated with herbicides. Workers during Project operations would utilize an existing driveway off State Route 98, park their vehicles in a designated staging/parking area north of the All-American Canal, and then walk across the All-American Canal at an existing crossing east of the Project

Site. No vehicles or construction vehicles are allowed to travel across this existing crossing. Designated shuttles would pick up workers at the south end of the crossing, and then travel west for approximately one mile along an existing dirt road to the Project Site.



Legend

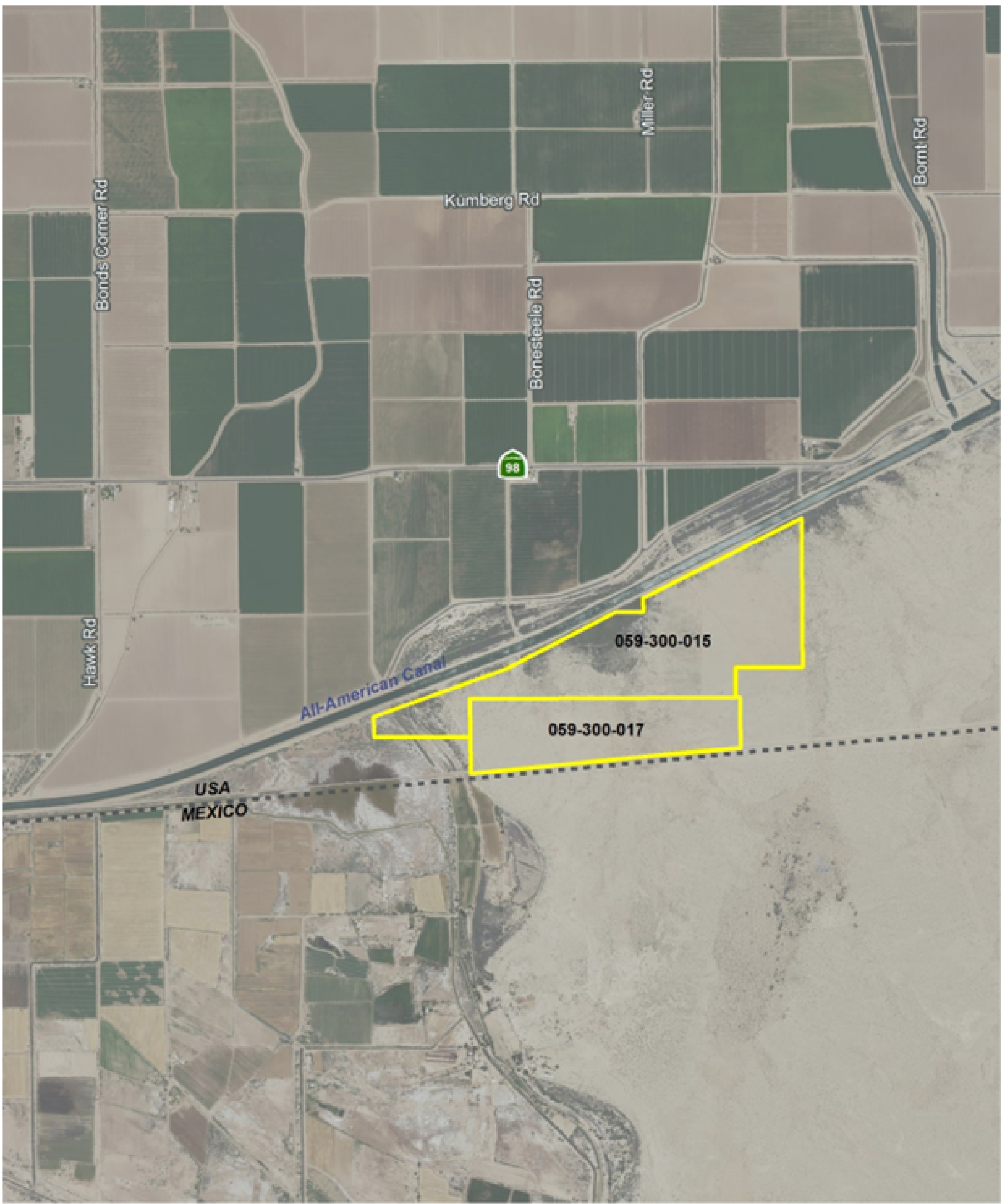
- VEGA SES 4 Project Area
- Renewable Energy Overlay Zone



0 Miles 2

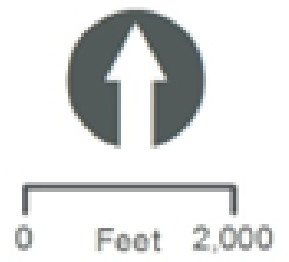
Map Date: 10/26/2022
 Photo (or Base) Source: HDR 2022

Figure 1-1. Regional Location Map
 2020-142 VEGA SES 4 Solar Energy Project



Legend

 VEGA SES 4 Project Parcels



Map Date: 10/26/2022
 Photo (or Base) Source: HDR 2022

Figure 1-2. Project Location Map
 2020-142 VEGA SES 4 Solar Energy Project

2.0 AIR QUALITY

2.1 Air Quality Setting

Air quality in a region is determined by its topography, meteorology, and existing air pollutant sources. These factors are discussed below, along with the current regulatory structure that applies to the Salton Sea Air Basin (SSAB), which encompasses the Project Site, pursuant to the regulatory authority of the ICAPCD.

Ambient air quality is commonly characterized by climate conditions, the meteorological influences on air quality, and the quantity and type of pollutants released. The air basin is subject to a combination of topographical and climatic factors that reduce the potential for high levels of regional and local air pollutants. The following section describes the pertinent characteristics of the air basin and provides an overview of the physical conditions affecting pollutant dispersion in the Project Area.

2.1.1 Salton Sea Air Basin

The California Air Resources Board (CARB) divides the State into air basins that share similar meteorological and topographical features. Imperial County, which extends over 4,482 square miles in the southeastern corner of California, lies in the SSAB, which includes the Imperial Valley and the central part of Riverside County, including the Coachella Valley. The province is characterized by the large-scale sinking and warming of air within the semi-permanent subtropical high-pressure center over the Pacific Ocean. The elevation in Imperial County ranges from about 230 feet below sea level in the Salton Sea to more than 2,800 feet on the mountain summits to the east.

2.1.1.1 Temperature and Precipitation

The flat terrain near the Salton Sea, intense heat from the sun during the day, and strong radiational cooling at night create deep convective thermals during the daytime and equally strong surface-based temperature inversions at night. The temperature inversions and light nighttime winds trap any local air pollution emissions near the ground. The area is subject to frequent hazy conditions at sunrise, followed by rapid daytime dissipation as winds pick up and the temperature warms. The lack of clouds and atmospheric moisture creates strong diurnal and seasonal temperature variations ranging from an average summer maximum of 108 degrees Fahrenheit (° F) down to a winter morning minimum of 38° F. The most pleasant weather occurs from about mid-October to early May when daily highs are in the 70s and 80s with very infrequent cloudiness or rainfall. Imperial County experiences rainfall on an average of only four times per year (>0.10 inches in 24 hours). The local area usually has three days of rain in winter and one thunderstorm day in August. The annual rainfall in this region is less than three inches per year (ICAPCD 2010).

2.1.1.2 Wind

Winds in the area are driven by a complex pattern of local, regional and global forces, but primarily reflect the temperature difference between the cool ocean to the west and the heated interior of the entire desert southwest. For much of the year, winds flow predominantly from the west to the east. In summer, intense solar heating in the Imperial Valley creates a more localized wind pattern, as air comes up from the southeast

via the Gulf of California. During periods of strong solar heating and intense convection, turbulent motion creates good mixing and low levels of air pollution. However, even strong turbulent mixing is insufficient to overcome the limited air pollution controls on sources in the Mexicali, Mexico area. Imperial County is predominately agricultural land. This is a factor in the cumulative air quality of the SSAB. The agricultural production generates dust and small particulate matter through the use of agricultural equipment on unpaved roads, land preparation, and harvest practices. The Imperial County experiences unhealthy air quality from photochemical smog and from dust due to extensive surface disturbance and the very arid climate (ICAPCD 2010).

2.1.1.3 Inversion

The entire county is affected by inversion layers, where warm air overlays cooler air. Inversion layers trap pollutants close to the ground. In the winter, these pollutant-trapping, ground-based inversions are formed during windless, clear-sky conditions, as cold air collects in low-lying areas such as valleys and canyons. Imperial County experiences surface inversions almost every day of the year. Due to strong surface heating, these inversions are usually broken allowing pollutants to be more easily dispersed (ICAPCD 2010).

2.1.2 Criteria Air Pollutants

Criteria air pollutants are defined as those pollutants for which the federal and state governments have established air quality standards for outdoor or ambient concentrations to protect public health with a determined margin of safety. Ozone (O₃), coarse particulate matter (PM₁₀), and fine particulate matter (PM_{2.5}) are generally considered to be regional pollutants because they or their precursors affect air quality on a regional scale. Pollutants such as carbon monoxide (CO), nitrogen dioxide (NO₂), and sulfur dioxide (SO₂) are considered to be local pollutants because they tend to accumulate in the air locally. PM is also considered a local pollutant. Health effects commonly associated with criteria pollutants are summarized in Table 2-1.

Table 2-1. Criteria Air Pollutants- Summary of Common Sources and Effects		
Pollutant	Major Manmade Sources	Human Health & Welfare Effects
CO	An odorless, colorless gas formed when carbon in fuel is not burned completely; a component of motor vehicle exhaust.	Reduces the ability of blood to deliver oxygen to vital tissues, effecting the cardiovascular and nervous system. Impairs vision, causes dizziness, and can lead to unconsciousness or death.
NO ₂	A reddish-brown gas formed during fuel combustion for motor vehicles, energy utilities and industrial sources.	Respiratory irritant; aggravates lung and heart problems. Precursor to ozone and acid rain. Causes brown discoloration of the atmosphere.
O ₃	Formed by a chemical reaction between reactive organic gases (ROGs) and nitrous oxides (N ₂ O) in the presence of sunlight. Common sources of these precursor pollutants include motor vehicle exhaust, industrial emissions, solvents, paints and landfills.	Irritates and causes inflammation of the mucous membranes and lung airways; causes wheezing, coughing and pain when inhaling deeply; decreases lung capacity; aggravates lung and heart problems. Damages plants; reduces crop yield.
PM ₁₀ & PM _{2.5}	Power plants, steel mills, chemical plants, unpaved roads and parking lots, wood-burning stoves and fireplaces, automobiles and others.	Increased respiratory symptoms, such as irritation of the airways, coughing, or difficulty breathing; aggravated asthma; development of chronic bronchitis; irregular heartbeat; nonfatal heart attacks; and premature death in people with heart or lung disease. Impairs visibility (haze).
SO ₂	A colorless, nonflammable gas formed when fuel containing sulfur is burned. Examples are refineries, cement manufacturing, and locomotives.	Respiratory irritant. Aggravates lung and heart problems. Can damage crops and natural vegetation. Impairs visibility.

Source: California Air Pollution Control Officers Association (CAPCOA 2013)

2.1.2.1 Carbon Monoxide

CO in the urban environment is associated primarily with the incomplete combustion of fossil fuels in motor vehicles. CO combines with hemoglobin in the bloodstream and reduces the amount of oxygen that can be circulated through the body. High CO concentrations can cause headaches, aggravate cardiovascular disease and impair central nervous system functions. CO concentrations can vary greatly over comparatively short distances. Relatively high concentrations of CO are typically found near crowded intersections and along heavy roadways with slow moving traffic. Even under the most severe meteorological and traffic conditions, high concentrations of CO are limited to locations within relatively short distances of the source. Overall CO emissions are decreasing as a result of the Federal Motor Vehicle Control Program, which has mandated increasingly lower emission levels for vehicles manufactured since 1973. CO levels in the SSAB are in compliance with the state and federal one- and eight-hour standards.

2.1.2.2 Nitrogen Oxides

Nitrogen gas comprises about 80 percent of the air and is naturally occurring. At high temperatures and under certain conditions, nitrogen can combine with oxygen to form several different gaseous compounds

collectively called nitric oxides (NO_x). Motor vehicle emissions are the main source of NO_x in urban areas. NO_x is very toxic to animals and humans because of its ability to form nitric acid with water in the eyes, lungs, mucus membrane, and skin. In animals, long-term exposure to NO_x increases susceptibility to respiratory infections, and lowering resistance to such diseases as pneumonia and influenza. Laboratory studies show that susceptible humans, such as asthmatics, who are exposed to high concentrations can suffer from lung irritation or possible lung damage. Precursors of NO_x, such as NO and NO₂, attribute to the formation of O₃ and PM_{2.5}. Epidemiological studies have also shown associations between NO₂ concentrations and daily mortality from respiratory and cardiovascular causes and with hospital admissions for respiratory conditions.

2.1.2.3 Ozone

O₃ is a secondary pollutant, meaning it is not directly emitted. It is formed when volatile organic compounds (VOCs) or ROGs and NO_x undergo photochemical reactions that occur only in the presence of sunlight. The primary source of ROG emissions is unburned hydrocarbons in motor vehicle and other internal combustion engine exhaust. NO_x forms as a result of the combustion process, most notably due to the operation of motor vehicles. Sunlight and hot weather cause ground-level O₃ to form. Ground-level O₃ is the primary constituent of smog. Because O₃ formation occurs over extended periods of time, both O₃ and its precursors are transported by wind and high O₃ concentrations can occur in areas well away from sources of its constituent pollutants.

People with lung disease, children, older adults, and people who are active can be affected when O₃ levels exceed ambient air quality standards. Numerous scientific studies have linked ground-level O₃ exposure to a variety of problems including lung irritation, difficult breathing, permanent lung damage to those with repeated exposure, and respiratory illnesses.

2.1.2.4 Particulate Matter

PM includes both aerosols and solid particulates of a wide range of sizes and composition. Of concern are those particles smaller than or equal to 10 microns in diameter size (PM₁₀) and small than or equal to 2.5 microns in diameter (PM_{2.5}). Smaller particulates are of greater concern because they can penetrate deeper into the lungs than larger particles. PM₁₀ is generally emitted directly as a result of mechanical processes that crush or grind larger particles or form the resuspension of dust, typically through construction activities and vehicular travel. PM₁₀ generally settles out of the atmosphere rapidly and is not readily transported over large distances. PM_{2.5} is directly emitted in combustion exhaust and is formed in atmospheric reactions between various gaseous pollutants, including NO_x, sulfur oxides (SO_x) and VOCs. PM_{2.5} can remain suspended in the atmosphere for days and/or weeks and can be transported long distances.

The principal health effects of airborne PM are on the respiratory system. Short-term exposure of high PM_{2.5} and PM₁₀ levels are associated with premature mortality and increased hospital admissions and emergency room visits. Long-term exposure is associated with premature mortality and chronic respiratory disease. According to the U.S. Environmental Protection Agency (USEPA), some people are much more sensitive than others to breathing PM₁₀ and PM_{2.5}. People with influenza, chronic respiratory and cardiovascular diseases, and the elderly may suffer worse illnesses; people with bronchitis can expect aggravated symptoms; and

children may experience decline in lung function due to breathing in PM₁₀ and PM_{2.5}. Other groups considered sensitive include smokers and people who cannot breathe well through their noses. Exercising athletes are also considered sensitive because many breathe through their mouths.

2.1.3 Toxic Air Contaminants

In addition to the criteria pollutants discussed above, toxic air contaminants (TACs) are another group of pollutants of concern. TACs are considered either carcinogenic or noncarcinogenic based on the nature of the health effects associated with exposure to the pollutant. For regulatory purposes, carcinogenic TACs are assumed to have no safe threshold below which health impacts would not occur, and cancer risk is expressed as excess cancer cases per one million exposed individuals. Noncarcinogenic TACs differ in that there is generally assumed to be a safe level of exposure below which no negative health impact is believed to occur. These levels are determined on a pollutant-by-pollutant basis.

There are many different types of TACs, with varying degrees of toxicity. Sources of TACs include industrial processes such as petroleum refining and chrome plating operations, commercial operations such as gasoline stations and dry cleaners, and motor vehicle exhaust. Additionally, diesel engines emit a complex mixture of air pollutants composed of gaseous and solid material. The solid emissions in diesel exhaust are known as diesel particulate matter (DPM). In 1998, California identified DPM as a TAC based on its potential to cause cancer, premature death, and other health problems (e.g., asthma attacks and other respiratory symptoms). Those most vulnerable are children (whose lungs are still developing) and the elderly (who may have other serious health problems). Overall, diesel engine emissions are responsible for the majority of California's known cancer risk from outdoor air pollutants. Public exposure to TACs can result from emissions from normal operations, as well as from accidental releases of hazardous materials during upset conditions. The health effects of TACs include cancer, birth defects, neurological damage, and death.

2.1.3.1 Diesel Exhaust

Most recently, CARB identified DPM as a TAC. DPM differs from other TACs in that it is not a single substance but rather a complex mixture of hundreds of substances. Diesel exhaust is a complex mixture of particles and gases produced when an engine burns diesel fuel. DPM is a concern because it causes lung cancer; many compounds found in diesel exhaust are carcinogenic. DPM includes the particle-phase constituents in diesel exhaust. The chemical composition and particle sizes of DPM vary between different engine types (heavy-duty, light-duty), engine operating conditions (idle, accelerate, decelerate), fuel formulations (high/low sulfur fuel), and the year of the engine (USEPA 2002). Some short-term (acute) effects of diesel exhaust include eye, nose, throat, and lung irritation, and diesel exhaust can cause coughs, headaches, light-headedness, and nausea. DPM poses the greatest health risk among the TACs; due to their extremely small size, these particles can be inhaled and eventually trapped in the bronchial and alveolar regions of the lung.

2.1.4 Ambient Air Quality

Ambient air quality at the Project Site can be inferred from ambient air quality measurements conducted at nearby air quality monitoring stations. CARB maintains more than 60 monitoring stations throughout California. O₃, PM₁₀ and PM_{2.5} are the pollutant species most potently affecting the Project region. As

described in detail below, the Project region is designated as a nonattainment area for the federal O₃ and PM_{2.5} standards and is also a nonattainment area for the state standards for O₃ and PM₁₀ (CARB 2019). The Niland-English Road air quality monitoring station (7711 English Road, Niland), located approximately 23.0 miles northwest of the Project Site, monitors ambient concentrations of O₃ and PM₁₀. The Brawley-Main Street #2 air quality monitoring station (220 Main Street, Brawley), located 15.0 miles west of the Project Site, monitors ambient concentrations of PM_{2.5}. Ambient emission concentrations will vary due to localized variations in emission sources and climate and should be considered “generally” representative of ambient concentrations in the Project Area.

Table 2-2 summarizes the published data concerning O₃, PM_{2.5} and PM₁₀ from the Niland-English Road and Brawley-Main Street #2 monitoring stations for each year that the monitoring data is provided. O₃, PM₁₀ and PM_{2.5} are the pollutant species most potently affecting the Project region.

Table 2-2. Summary of Ambient Air Quality Data			
Pollutant Standards	2018	2019	2020
O₃- Niland-English Road			
Max 1-hour concentration (ppm)	0.060	0.060	0.054
Max 8-hour concentration (ppm) (state/federal)	0.055 / 0.055	0.055 / 0.054	0.046 / 0.045
Number of days above 1-hour standard (state/federal)	0 / 0	0 / 0	0 / 0
Number of days above 8-hour standard (state/federal)	0 / 0	0 / 0	0 / 0
PM₁₀- Niland-English Road			
Max 24-hour concentration (µg/m ³) (state/federal)	333.8 / 331.5	156.3 / 155.7	241.3 / 239.8
Number of days above 24-hour standard (state/federal)	* / 10.1	49.3 / 1.0	68.9 / 1.0
PM_{2.5}- Brawley-Main Street			
Max 24-hour concentration (µg/m ³) (state/federal)	55.1 / 55.1	28.9 / 28.9	23.7 / 23.7
Number of days above federal 24-hour standard	6.1	0	0

Source: CARB 2021a

µg/m³ = micrograms per cubic meter; ppm = parts per million

* = Insufficient data available

The USEPA and CARB designate air basins or portions of air basins and counties as being in “attainment” or “nonattainment” for each of the criteria pollutants. Areas that do not meet the standards are classified as nonattainment areas. The National Ambient Air Quality Standards (NAAQS) (other than O₃, PM₁₀ and PM_{2.5} and those based on annual averages or arithmetic mean) are not to be exceeded more than once per year. The NAAQS for O₃, PM₁₀, and PM_{2.5} are based on statistical calculations over one- to three-year periods, depending on the pollutant. The California Ambient Air Quality Standards (CAAQS) are not to be exceeded during a three-year period. The attainment status for the portion of the SSAB encompassing the Project Site is included in Table 2-3.

Table 2-3. Attainment Status of Criteria Pollutants in the Imperial County Portion of the SSAB

Pollutant	State Designation	Federal Designation
O ₃	Nonattainment	Nonattainment
PM ₁₀	Nonattainment	Attainment
PM _{2.5}	Attainment	Nonattainment
CO	Attainment	Unclassified/Attainment
NO ₂	Attainment	Unclassified/Attainment
SO ₂	Attainment	Unclassified/Attainment

Source: CARB 2019

The determination of whether an area meets the state and federal standards is based on air quality monitoring data. Some areas are unclassified, which means there is insufficient monitoring data for determining attainment or nonattainment. Unclassified areas are typically treated as being in attainment. Because the attainment/nonattainment designation is pollutant-specific, an area may be classified as nonattainment for one pollutant and attainment for another. Similarly, because the state and federal standards differ, an area could be classified as attainment for the federal standards of a pollutant and as nonattainment for the state standards of the same pollutant. The region is designated as a nonattainment area for the federal O₃ and PM_{2.5} standards and is also a nonattainment area for the state standards for O₃ and PM₁₀ (CARB 2019).

2.1.5 Sensitive Receptors

Sensitive receptors are defined as facilities or land uses that include members of the population who are particularly sensitive to the effects of air pollutants, such as children, the elderly, and people with illnesses. Examples of these sensitive receptors are residences, schools, hospitals, and daycare centers. CARB has identified the following groups of individuals as the most likely to be affected by air pollution: the elderly over 65, children under 14, athletes, and persons with cardiovascular and chronic respiratory diseases such as asthma, emphysema, and bronchitis. The nearest existing sensitive receptor to the Project Site is a single-family residence located approximately 0.5 miles from the northeastern corner of the Project boundary.

2.2 Regulatory Framework

2.2.1 Federal

2.2.1.1 Clean Air Act

The Clean Air Act (CAA) of 1970 and the CAA Amendments of 1971 required the USEPA to establish the NAAQS, with states retaining the option to adopt more stringent standards or to include other specific pollutants. On April 2, 2007, the Supreme Court found that carbon dioxide (CO₂) is an air pollutant covered by the CAA; however, no NAAQS have been established for CO₂.

These standards are the levels of air quality considered safe, with an adequate margin of safety, to protect the public health and welfare. They are designed to protect those “sensitive receptors” most susceptible to further respiratory distress such as asthmatics, the elderly, very young children, people already weakened by other disease or illness, and persons engaged in strenuous work or exercise. Healthy adults can tolerate occasional exposure to air pollutant concentrations considerably above these minimum standards before adverse effects are observed.

The USEPA has classified air basins (or portions thereof) as being in attainment, nonattainment, or unclassified for each criteria air pollutant, based on whether or not the NAAQS have been achieved. If an area is designated unclassified, it is because inadequate air quality data were available as a basis for a nonattainment or attainment designation. Table 2-3 lists the federal attainment status of the SSAB for the criteria pollutants.

2.2.2 State

2.2.2.1 California Clean Air Act

The California Clean Air Act (CCAA) allows the state to adopt ambient air quality standards and other regulations provided that they are at least as stringent as federal standards. CARB, a part of the California Environmental Protection Agency, is responsible for the coordination and administration of both federal and state air pollution control programs within California, including setting the CAAQS. CARB also conducts research, compiles emission inventories, develops suggested control measures, and provides oversight of local programs. CARB establishes emissions standards for motor vehicles sold in California, consumer products (such as hairspray, aerosol paints, and barbecue lighter fluid), and various types of commercial equipment. It also sets fuel specifications to further reduce vehicular emissions. CARB also has primary responsibility for the development of California’s State Implementation Plan (SIP), for which it works closely with the federal government and the local air districts.

2.2.2.2 California State Implementation Plan

The CCAA (and its subsequent amendments) requires the state to prepare an air quality control plan referred to as the SIP. The SIP is a living document that is periodically modified to reflect the latest emissions inventories, plans, and rules and regulations of air basins as reported by the agencies with jurisdiction over them. The CAA Amendments dictate that states containing areas violating the NAAQS revise their SIPs to include extra control measures to reduce air pollution. The SIP includes strategies and control measures to attain the NAAQS by deadlines established by the CAA. The USEPA has the responsibility to review all SIPs to determine if they conform to the requirements of the CAA. State law makes CARB the lead agency for all purposes related to the SIP. Local air districts and other agencies prepare SIP elements and submit them to CARB for review and approval. CARB then forwards SIP revisions to the USEPA for approval and publication in the Federal Register.

Local air districts, such as the ICAPCD, prepare air quality attainment plans or air quality management plans and submit them to CARB for review, approval, and incorporation into the applicable SIP. The air districts develop the strategies stated in the SIPs for achieving air quality standards on a regional basis.

For 8-Hour O₃, the ICAPCD adopted the 2017 8-hour Ozone State Implementation Plan in October 2018. The plan includes control measures which are an integral part of how the ICAPCD currently controls the ROG and NO_x emissions within the O₃ nonattainment areas. The overall strategy includes programs and control measures which represent the implementation of Reasonable Available Control Technology (40 CFR 51.912) and the assurance that stationary sources maintain a net decrease in emissions.

For PM₁₀, the ICAPCD adopted the PM₁₀ State Implementation Plan in 2018, which maintained previously adopted fugitive dust control measures (Regulation VIII). The USEPA had previously approved Regulation VIII fugitive dust rules into the Imperial County portion of the California SIP in 2013.

For PM_{2.5}, the ICAPCD adopted the PM_{2.5} SIP in April 2018. This SIP concluded that the majority of the PM_{2.5} emissions resulted from transport in nearby Mexico. Specifically, the SIP demonstrates attainment of the 2006 PM_{2.5} NAAQS “but for” transport of international emissions from Mexicali, Mexico. In accordance with the CCAA, the PM_{2.5} SIP satisfies the attainment demonstration requirement satisfying the provisions of the CCAA.

The ICAPCD is working cooperatively with counterparts from Mexico to implement emissions reductions strategies and projects for air quality improvements at the border. The two countries strive to achieve these goals through local input from states, County governments, and citizens. Within the Mexicali and Imperial Valley area, the Air Quality Task Force (AQTF) has been organized to address those issues unique to the border region known as the Mexicali/Imperial air shed. The AQTF membership includes representatives from Federal, State, and local governments from both sides of the border, as well as representatives from academia, environmental organizations, and the general public. This group was created to promote regional efforts to improve the air quality monitoring network, emissions inventories, and air pollution transport modeling development, as well as the creation of programs and strategies to improve air quality.

2.2.2.3 *Tanner Air Toxics Act & Air Toxics “Hot Spots” Information and Assessment Act*

CARB’s Statewide comprehensive air toxics program was established in 1983 with Assembly Bill (AB) 1807, the Toxic Air Contaminant Identification and Control Act (Tanner Air Toxics Act of 1983). AB 1807 created California’s program to reduce exposure to air toxics and sets forth a formal procedure for CARB to designate substances as TACs. Once a TAC is identified, CARB adopts an airborne toxics control measure (ATCM) for sources that emit designated TACs. If there is a safe threshold for a substance at which there is no toxic effect, the control measure must reduce exposure to below that threshold. If there is no safe threshold, the measure must incorporate toxics best available control technology to minimize emissions.

CARB also administers the state’s mobile source emissions control program and oversees air quality programs established by state statute, such as AB 2588, the Air Toxics “Hot Spots” Information and Assessment Act of 1987. Under AB 2588, TAC emissions from individual facilities are quantified and prioritized by the air quality management district or air pollution control district. High priority facilities are required to perform a health risk assessment (HRA) and, if specific thresholds are exceeded, required to communicate the results to the public in the form of notices and public meetings. In September 1992, the “Hot Spots” Act was amended by Senate Bill (SB) 1731, which required facilities that pose a significant health risk to the community to reduce their risk through a risk management plan.

2.2.3 Local

2.2.3.1 Imperial County Air Pollution Control District

The ICAPCD is the local air quality agency and shares responsibility with CARB for ensuring that state and federal ambient air quality standards are achieved and maintained in the SSAB. Furthermore, ICAPCD adopts and enforces controls on stationary sources of air pollutants through its permit and inspection programs and regulates agricultural burning. Other ICAPCD responsibilities include monitoring ambient air quality, preparing clean air plans, planning activities such as modeling and maintenance of the emission inventory, and responding to citizen air quality complaints.

To achieve and maintain ambient air quality standards, the ICAPCD has adopted various rules and regulations for the control of airborne pollutants. The ICAPCD Rules and Regulations that are applicable to the Proposed Project include, but are not limited to, ICAPCD Regulation VIII (Fugitive Dust Rules). The purpose of this regulation is to reduce the amount of PM₁₀ entrained in the ambient air as a result of emissions generated from construction and other earthmoving activities by requiring actions to prevent, reduce, or mitigate PM₁₀ emissions. Regulation VIII requires the Project to adopt best available control measures to minimize emissions from surface-disturbing activities. These measures include the following (ICAPCD 2017):

- All disturbed areas, including bulk material storage which is not being actively utilized, shall be effectively stabilized and visible emissions shall be limited to no greater than 20 percent opacity for dust emissions by using water, chemical stabilizers, dust suppressants, tarps, or other suitable material such as vegetative ground cover.
- All on-site and off-site unpaved roads will be effectively stabilized, and visible emissions shall be limited to no greater than 20 percent opacity for dust emissions by paving, chemical stabilizers, or dust suppressants.
- All unpaved traffic areas of 1 acre or more with 75 or more average vehicle trips per day will be effectively stabilized and visible emissions shall be limited to no greater than 20 percent opacity for dust emissions by paving, chemical stabilizers, dust suppressants, and/or watering.
- The transport of bulk materials shall be completely covered unless 6 inches of freeboard space from the top of the container is maintained with no spillage and loss of bulk material. In addition, the cargo compartment of all haul trucks is to be cleaned and/or washed at the delivery site after removal of bulk material.
- All track-out or carry-out will be cleaned at the end of each workday or immediately when mud or dirt extends a cumulative distance of 50 linear feet or more onto a paved road within an urban area.
- Bulk material handling or transfer shall be stabilized prior to handling or at points of transfer with application of sufficient water, chemical stabilizers, or by sheltering or enclosing the operation and transfer line.

- The construction of any new unpaved road is prohibited within any area with a population of 500 or more unless the road meets the definition of a temporary unpaved road. Any temporary unpaved road shall be effectively stabilized and visible emissions shall be limited to no greater than 20 percent opacity for dust emission by paving, chemical stabilizers, dust suppressants and/or watering.

In addition, there are other ICAPCD rules and regulations, not detailed here, which may apply to the Proposed Project, but are administrative or descriptive in nature. These include rules associated with fees, enforcement and penalty actions, and variance procedures.

2.3 Air Quality Emissions Impact Assessment

2.3.1 Thresholds of Significance

The impact analysis provided below is based on the following California Environmental Quality Act (CEQA) Guidelines Appendix G thresholds of significance. The Project would result in a significant impact to air quality if it would do any of the following:

1. Conflict with or obstruct implementation of any applicable air quality plan.
2. Result in a cumulatively considerable net increase of any criteria pollutant for which the Project region is nonattainment under an applicable federal or state ambient air quality standard (including releasing emissions which exceed quantitative thresholds for ozone precursors).
3. Expose sensitive receptors to substantial pollutant concentrations.
4. Result in other emissions (such as those leading to odors adversely affecting a substantial number of people).

2.3.1.1 Imperial County Air Pollution Control District Thresholds

The significance criteria established by the applicable air quality management or air pollution control district (ICAPCD) may be relied upon to make the above determinations. The ICAPCD has identified significance thresholds for use in evaluating project impacts under CEQA. Accordingly, the ICAPCD-recommended thresholds of significance are used to determine whether implementation of the proposed Project would result in a significant air quality impact. Significance thresholds for evaluation construction and operational air quality impacts are listed in Table 2-4.

Table 2-4. ICAPCD Significance Thresholds – Pounds per Day			
Criteria Pollutant and Precursors	Construction Activities	Operations	
	Average Daily Emissions (lbs/day)	Average Daily Emissions (lbs/day)	
		Tier I Threshold	Tier II Threshold
ROG	75	<137	> 137
NO _x	100	<137	> 137
PM ₁₀	150	<150	> 150
PM _{2.5}	N/A	<550	> 550
CO	550	<550	> 550
SO ₂	N/A	<150	> 150

Source: ICAPCD 2017

Projects that are predicted to exceed Tier I thresholds require implementation of applicable ICAPCD standard mitigation measures to be considered less than significant. Projects exceeding Tier II thresholds are required to implement applicable ICAPCD standard mitigation measures, as well as applicable discretionary mitigation measures. Projects that exceed the Tier II thresholds after implementation of standard and discretionary mitigation measures would be considered to have a potentially significant impact to human health and welfare.

By its very nature, air pollution is largely a cumulative impact. No single project is sufficient in size, by itself, to result in nonattainment of ambient air quality standards. Instead, a project's individual emissions contribute to existing cumulatively significant adverse air quality impacts. If a project's individual emissions exceed its identified significance thresholds, the project would be cumulatively considerable. Projects that do not exceed significance thresholds would not be considered cumulative considerable.

2.3.2 Methodology

Air quality impacts were assessed in accordance with methodologies recommended by the ICAPCD. Where criteria air pollutant quantification was required, emissions were modeled using the California Emissions Estimator Model (CalEEMod), version 2020.4.0. CalEEMod is a statewide land use emissions computer model designed to quantify potential criteria pollutant emissions associated with both construction and operations from a variety of land use projects. Project construction-generated air pollutant emissions were calculated using CalEEMod model defaults for Imperial County coupled with information provided by the Project applicant. For instance, as described in the Section 1.2, *Project Overview*, construction activities would primarily involve demolition and grubbing, grading of the Project Site to establish access roads and pads for electrical equipment, trenching for underground electrical collection lines, and the installation of solar equipment and security fencing. Construction is estimated to take 12-18 months and would begin in late 2022 or 2023. The number of on-site construction workers for the solar facility is not expected to exceed 150 workers at any time. The number of on-site construction workers for the BESS and substation is not expected to exceed 100 workers at any one time. According to the Traffic Study prepared for the Project

(KOA 2020), Project construction would generate a maximum of 500 construction worker-commute trips in a single day.

Construction workers would utilize an existing driveway off State Route 98 and then park their vehicles in a designated staging/parking area, approximately 3.5 acres in size, north of the All-American Canal. The staging/parking area is proposed to be improved to facilitate access and minimize parking conflicts. Construction workers would then walk across the All-American Canal at an existing crossing east of the Project Site. No vehicles or construction vehicles are allowed to travel across this existing crossing. Designated shuttles would pick up the construction workers at the south end of the crossing, and then travel west for approximately one mile along an existing dirt road to the Project Site. The Traffic Impact Study prepared for the Project (KOA 2020) identifies the site trip distribution of construction worker commute traffic. It is noted that all of the roadways identified as construction worker commute routes are paved (KOA 2020). Thus, the PM emissions associated with construction workers traversing 1.15 miles of unpaved roads are accounted (0.15 mile of roadway at staging/parking area and 1.0 mile of dirt road south of the All-American Canal).

All heavy-duty construction vehicles would cross the All-American Canal at Gordon Wells Road located approximately 20 miles east of the Project Site. An estimated two trucks hauling construction equipment and Project materials would arrive at the Project Site each day during the first few weeks of construction via Gordon Wells Road and the 20 miles of existing dirt road paralleling the U.S./Mexico Border. The PM emissions associated with two haul trucks traversing this existing dirt road to and from the site daily are accounted for.

Operational air pollutant emissions account for the maximum three workers visiting the site in a single day. Such visits include inspections, equipment servicing, site and landscape clearing, and periodic washing of the PV modules if needed (up to two times per year) to maintain power generation efficiency. Therefore, operational onsite equipment use is accounted in addition to the consumption of 10 acre-feet (3,259,000 gallons) of water annually.

2.3.3 Impact Analysis

2.3.3.1 Project Construction-Generated Criteria Air Quality Emissions

Emissions associated with Project implementation would be temporary and short-term but have the potential to represent a significant air quality impact. Two basic sources of short-term emissions will be generated through Project implementation: operation of the heavy-duty equipment (i.e., excavators, loaders, haul trucks) and the creation of fugitive dust during clearing and grading. Construction activities such as excavation and grading operations, construction vehicle traffic, and wind blowing over exposed soils would generate exhaust emissions and fugitive PM emissions that affect local air quality at various times during construction. Effects would be variable depending on the weather, soil conditions, the amount of activity taking place, and the nature of dust control efforts. The dry climate of the area during the summer months creates a high potential for dust generation. Construction activities would be subject to ICAPCD Regulation VIII which, as previously described, requires taking reasonable precautions to reduce the amount of PM₁₀ entrained in the ambient air as a result of emissions generated from construction and other

earthmoving activities by requiring actions to prevent, reduce, or mitigate PM₁₀ emissions. Regulation VIII requires the Project to adopt best available control measures to minimize emissions from surface-disturbing activities to comply with ICAPCD Regulation VIII (Fugitive Dust Rules).

Emissions associated with Project off-road equipment, worker commute trips, and ground disturbance were calculated using the CARB-approved CalEEMod computer program, which is designed to model emissions for land use development projects, based on typical construction requirements. See Section 2.3.2, *Methodology*, and Attachment A for more information regarding the construction assumptions, including types of construction equipment used and Project duration used in this analysis.

Predicted maximum daily emissions attributable to Project construction are summarized in Table 2-5. Such emissions are short-term and of temporary duration, lasting only as long as Project construction activities occur, but would be considered a significant air quality impact if the volume of pollutants generated exceeds the ICAPCD thresholds of significance.

Table 2-5. Unmitigated Project Construction-Generated Emissions						
Construction Year	Pollutant (pounds per day)					
	ROG	NO_x	CO	SO₂	PM₁₀	PM_{2.5}
Construction in Calendar Year One	5.66	57.65	53.83	0.10	949.93	96.64
Construction in Calendar Year Two	5.18	30.12	52.46	0.09	949.82	96.54
ICAPCD Significance Threshold	75	100	550	N/A	150	N/A
Exceed ICAPCD Threshold?	No	No	No	No	Yes	No

Source: CalEEMod version 2020.4.0. Refer to Attachment A for Model Data Outputs.

Notes: Pounds per day taken from the season with the highest output.

As shown in Table 2-5, emissions generated during Project construction would exceed the ICAPCD significance threshold for PM₁₀. Project construction PM₁₀ is generated primarily from construction worker commute-traffic and delivery trucks traversing dirt roads. As previously described, all heavy-duty construction vehicles would travel on 20 miles of existing dirt road paralleling the U.S./Mexico Border to reach the Project Site. Commuting construction workers would traverse 1.15 miles of unpaved roads (0.15 mile of roadway at staging/parking area and 1.0 mile of dirt road south of the All-American Canal). Fugitive PM₁₀ emissions would also be generated on the Project construction site with grading operations, heavy-duty equipment moving over bare dirt, and wind blowing over exposed and freshly disturbed soils. Thus, mitigation measure AQ-1 is required to reduce impacts to less than significant levels.

AQ-1: Project Construction Dust Suppression

During construction activities the construction contractor shall employ the following PM₁₀ reducing measures:

1. All unpaved roads associated with construction shall be effectively stabilized of dust emissions using Imperial County Air Pollution Control District-approved chemical stabilizers/suppressant before the commencement of construction, and every 30 days thereafter until the end of all construction activities. Unpaved roads associated with construction include:
 - The driveway entrance off State Route 98,
 - The Project designated 3.5-acre staging/parking area north of the All-American Canal,
 - The 1.0 mile of dirt road south of the All-American Canal,
 - The 20 miles of existing dirt road paralleling the U.S./Mexico Border from Gordon Wells Road to the Project Site.

Monthly application of Imperial County Air Pollution Control District-approved chemical stabilizers/suppressant shall be applied at a rate of 0.1 gallon/ square yard of chemical dust suppressant.

2. Prior to any earthmoving activity, the applicant shall submit a construction dust control plan and obtain Imperial County Air Pollution Control District and Imperial County Planning and Development Services Department (ICPDS) approval.
3. Pursuant to ICAPCD, all construction sites, regardless of size, must comply with the requirements contained within Regulation VIII – Fugitive Dust Control Measures. Whereas these Regulation VIII measures are mandatory and are not considered project environmental mitigation measures, the ICAPCD CEQA Handbook's required additional standard and enhanced mitigation measures listed below shall be implemented prior to and during construction. ICAPCD will verify implementation and compliance with these measures as part of the grading permit review/approval process.

ICAPCD Standard Measures for Fugitive Dust (PM₁₀) Control

- All disturbed areas, including bulk material storage, which is not being actively utilized, shall be effectively stabilized and visible emissions shall be limited to no greater than 20 percent opacity for dust emissions by using water, chemical stabilizers, dust suppressants, tarps, or other suitable material, such as vegetative ground cover.
- All on-site and offsite unpaved roads will be effectively stabilized, and visible emissions shall be limited to no greater than 20 percent opacity for dust emissions by paving, chemical stabilizers, dust suppressants, and/or watering.
- All unpaved traffic areas 1 acre or more with 75 or more average vehicle trips per day will be effectively stabilized and visible emissions shall be limited to no greater than 20 percent opacity for dust emissions by paving, chemical stabilizers, dust suppressants, and/or watering.
- The transport of bulk materials shall be completely covered unless 6 inches of freeboard space from the top of the container is maintained with no spillage and loss of bulk

material. In addition, the cargo compartment of all haul trucks is to be cleaned and/or washed at delivery site after removal of bulk material.

- All track-out or carry-out will be cleaned at the end of each workday or immediately when mud or dirt extends a cumulative distance of 50 linear feet or more onto a paved road within an urban area.
- Movement of bulk material handling or transfer shall be stabilized prior to handling or at points of transfer with application of sufficient water, chemical stabilizers, or by sheltering or enclosing the operation and transfer line.
- The construction of any new unpaved road is prohibited within any area with a population of 500 or more unless the road meets the definition of a temporary unpaved road. Any temporary unpaved road shall be effectively stabilized, and visible emissions shall be limited to no greater than 20 percent opacity for dust emission by paving, chemical stabilizers, dust suppressants, and/or watering.

ICAPCD “Discretionary” Measures for Fugitive Dust (PM₁₀) Control

- Water exposed soil only in those areas where active grading and vehicle movement occurs with adequate frequency to control dust.
- Replace ground cover in disturbed areas as quickly as possible.
- Automatic sprinkler system installed on all soil piles.
- Vehicle speed for all construction vehicles shall not exceed 15 miles per hour on any unpaved surface at the construction site.
- Develop a trip reduction plan to achieve a 1.5 average vehicle ridership for construction employees.
- Implement a shuttle service to and from retail services and food establishments during lunch hours.

Standard Mitigation Measures for Construction Combustion Equipment

- Use of alternative fueled or catalyst equipped diesel construction equipment, including all off-road and portable diesel-powered equipment.
- Minimize idling time either by shutting equipment off when not in use or reducing the time of idling to 5 minutes as a maximum.
- Limit, to the extent feasible, the hours of operation of heavy-duty equipment and/or the amount of equipment in use.
- Replace fossil fueled equipment with electrically driven equivalents (provided they are not run via a portable generator set).

Enhanced Mitigation Measures for Construction Equipment

To help provide a greater degree of reduction of PM emissions from construction combustion equipment, Imperial County Air Pollution Control District recommends the following enhanced measures.

- Curtail construction during periods of high ambient pollutant concentrations; this may include ceasing of construction activity during the peak hour of vehicular traffic on adjacent roadways.
- Implement activity management (e.g., rescheduling activities to reduce short-term impacts).

Table 2-6 shows the results of construction emissions with implementation of Mitigation Measure AQ-1.

Table 2-6. Mitigated Project Construction-Generated Emissions						
Construction Year	Pollutant (pounds per day)					
	ROG	NO_x	CO	SO₂	PM₁₀	PM_{2.5}
Construction in Calendar Year One	5.66	57.61	53.83	0.10	91.86	11.00
Construction in Calendar Year Two	5.18	30.03	52.46	0.09	91.75	10.90
ICAPCD Significance Threshold	75	100	550	N/A	150	N/A
Exceed ICAPCD Threshold?	No	No	No	No	No	No

Source: CalEEMod version 2020.4.0. Refer to Attachment A for Model Data Outputs.

Notes: Pounds per day taken from the season with the highest output. PM reduction values associated with the implementation of soil stabilizers on unpaved roads monthly over the course of construction per email communication with Monica Soucier of the ICAPCD (2021).

As shown in Table 2-6, emissions generated during Project construction would not exceed the ICAPCD's thresholds of significance with implementation of mitigation measure AQ-1. Therefore, criteria pollutant emissions generated during Project construction would not result in a cumulatively considerable net increase of any criteria pollutant for which the Project region is nonattainment under an applicable federal or state ambient air quality standard.

2.3.3.2 Operational Criteria Air Quality Emissions

Although limited, implementation of the Project would result in long-term operational emissions of criteria air pollutants such as PM₁₀, PM_{2.5}, CO, and SO₂ as well as O₃ precursors such as ROG and NO_x. Project-generated increases in emissions would be predominately associated with motor vehicle use for routine maintenance work and site security. Long-term operational emissions attributable to the Project are identified in Table 2-7 and compared to the operational significance thresholds promulgated by the ICAPCD.

Table 2-7. Operational-Related Emissions (Regional Significance Analysis)						
Emission Source	Pollutant (pounds per day)					
	ROG	NO_x	CO	SO₂	PM₁₀	PM_{2.5}
Summer Emissions						
Area	13.59	0.00	0.06	0.00	0.00	0.00
Energy	0.26	2.42	2.03	0.01	0.18	0.18
Mobile	0.02	0.03	0.31	0.00	4.84	0.49
Offroad Equipment	1.16	11.09	12.70	0.02	0.56	0.51
Total:	15.04	13.55	15.11	0.03	5.59	1.19
<i>ICAPCD Significance Threshold</i>	<i>137</i>	<i>137</i>	<i>150</i>	<i>550</i>	<i>550</i>	<i>150</i>
Exceed ICAPCD Significance Threshold?	No	No	No	No	No	No
Winter Emissions						
Area	13.59	0.00	0.06	0.00	0.00	0.00
Energy	0.26	2.42	2.03	0.01	0.18	0.18
Mobile	0.02	0.03	0.24	0.00	4.84	0.49
Offroad Equipment	1.16	11.09	12.70	0.02	0.56	0.51
Total:	15.04	13.55	15.04	0.03	5.59	1.19
<i>ICAPCD Significance Threshold</i>	<i>137</i>	<i>137</i>	<i>150</i>	<i>550</i>	<i>550</i>	<i>150</i>
Exceed ICAPCD Significance Threshold?	No	No	No	No	No	No

Source: CalEEMod version 2020.4.0. Refer to Attachment A for Model Data Outputs.

As shown in Table 2-7, the Project's emissions would not exceed any ICAPCD's thresholds for any criteria air pollutants during operation. Additionally, the purpose of the Project is the operation of a renewable energy and storage facility. Once in operation, it will decrease the need for energy from fossil fuel-based power plants in the state (see Table 2-8). Thus, once operational the Project would represent a beneficial impact to air quality.

2.3.3.3 Conflict with an Applicable Air Quality Management Plan

As previously described, the Project region is classified as nonattainment for federal O₃ and PM_{2.5} standards (CARB 2019). The USEPA, under the provisions of the CAA, requires each state with regions that have not attained the federal air quality standards to prepare a SIP, detailing how these standards are to be met in each local area. The SIP is a legal agreement between each state and the federal government to commit resources to improving air quality. It serves as the template for conducting regional and project-level air

quality analysis. CARB is the lead agency for developing the SIP in California. Local air districts, such as the ICAPCD, prepare air quality attainment plans or air quality management plans and submit them to CARB for review, approval, and incorporation into the applicable SIP. The air districts develop the strategies stated in the SIPs for achieving air quality standards on a regional basis.

The region's SIP is constituted of the ICAPCD air quality plans: 2018 PM₁₀ SIP, the 2018 Annual PM_{2.5} SIP, the 2017 8-Hour Ozone SIP, 2013 24-Hour PM_{2.5} SIP, the 2009 1997 8-hour Ozone RACT SIP, the 2009 PM₁₀ SIP and the 2008 Ozone Early Progress Plans. Project compliance with all of the ICAPCD rules and regulations results in conformance with the ICAPCD air quality plans. These air quality attainment plans are a compilation of new and previously submitted plans, programs (such as monitoring, modeling, permitting, etc.), district rules, state regulations, and federal controls describing how the state will attain ambient air quality standards. These SIP plans and associated control measures are based on information derived from projected growth in Imperial County in order to project future emissions and then determine strategies and regulatory controls for the reduction of emissions. Growth projections are based on the general plans developed by Imperial County and the incorporated cities in the county.

As previously described, the Project consists of the construction of a 100-MW alternating current solar field, consisting of 226,800 tracker modules in 7,560 strings and associated collector and inverter facilities, and a 100 MW BESS, on approximately 585 acres of vacant land. The Project would not result in population growth and would not cause an increase in currently established population projections. The Project does not include residential development or large local or regional employment centers, and thus would not result in significant population or employment growth.

Furthermore, the operation of the Project would create renewable energy over its planned lifetime and decrease the need for energy from fossil fuel-based power plants in the state, which is considered a beneficial impact to statewide air quality. The energy produced by the Project would displace the criteria pollutant emissions which would otherwise be produced by existing business-as-usual power generation resources (including natural gas and coal).

Table 2-8 shows the emissions that would potentially be displaced by the Proposed Project. Note that this estimate only includes that associated with the combustion of fossil fuels; it does not include the vehicle trips associated with the Project's operations, and it similarly does not include operational employee trips associated with natural gas or coal combustion nor the emissions associated with extracting and transporting those power sources. In addition, this estimate only includes the displacement of that portion of the California market that comes from fossil fuels and does not include the approximate 50 percent of the California electricity generated by non-combustion sources (wind, solar, nuclear, hydro-electric) (California Energy Commission [CEC] 2020). Displacement of fossil fuel emissions has a direct beneficial effect on human health for those receptors downwind of the location of the fossil fuel power plants.

Table 2-8. Proposed Project Displaced Criteria Pollutant Emissions (Tons)						
Construction Year	Emissions (Tons)					
	ROG	NO_x	CO	SO₂	PM₁₀	PM_{2.5}
Emissions Displaced Annually (tons)						
Displaced Natural Gas-Source Emissions	0.00	2.14	0.65	1.47	2.03	0.82
Displaced Coal-Source Emissions	0.00	13.97	0.58	0.66	0.10	0.07
Total	0.00	16.11	1.23	2.13	2.13	0.89
Emissions Displaced over 30 Years (tons)						
Total	0	483.37	36.93	64.03	63.93	26.75

Source: Displaced emissions calculated by ECORP using USEPA's AP-42 Fifth Edition Compilation of Air Emissions Factors 1995; 2015. See Attachment B.

Notes: In order to provide a conservative analysis, the proposed Project is assumed to generate electricity 25 percent of the time available (2,190 hours annually). Heat Rate indicates the energy generator efficiency of existing fossil-fuel based energy generators. The heat rate of a power plant measures the amount of fuel used to generate one unit of electricity. Power plants with lower heat rates are more efficient than plants with higher heat rates. The CEC's "Updated Thermal Power Plant Efficiency Measures and Operational Characteristics for Production Cost Modeling" (2019) estimates heat rates and operating ranges for thermal power plants supplying energy to California. The average heat rate of power plants types are as follows:

**Steam Boiler fueled by coal: 10,800 heat rate **Steam Boiler fueled by natural gas: 10,200 heat rate **Gas Turbine: 10,100 heat rate **Combined natural gas Boiler and Turbine: 7,640 heat rate.

By omitting steam boilers fueled by coal since so little of California's energy is derived from coal, the average heat rate = 9,313 [(10,100 + 10,200 + 7,640) ÷ 3 = 9,313]. 100 MW (219,000,000 annual kWh) x 9,313 heat rate = 2,039,547,000,000 Btu displaced from fossil fuel production. Fossil fuel-based energy consumption in California is predominately derived from natural gas (37.06 percent). Coal constitutes 2.74 percent of all fossil fuel-based energy. Therefore, 865,175,837,400 of the displaced Btu is displaced natural gas consumption and 55,883,587,800 of the displaced Btu is displaced coal. The heat content of coal is assumed at 24 million Btu per ton of coal burned. At a rate of 24 million Btu per ton of coal burned, the Project would displace 2,328 tons of burned coal annually.

As shown, the Project would potentially displace approximately 483 tons of NO_x, 37 tons of CO, 64 tons of SO₂, 64 tons of PM₁₀, and 27 tons of PM_{2.5} over the course of 30 years. Furthermore, as demonstrated in Table 2-6 and Table 2-7, the Project would not exceed the applicable significance thresholds for construction or operational-source emissions.

2.3.3.4 Exposure of Sensitive Receptors to Toxic Air Contaminants

As previously described, sensitive receptors are defined as facilities or land uses that include members of the population that are particularly sensitive to the effects of air pollutants, such as children, the elderly, and people with illnesses. Examples of these sensitive receptors are residences, schools, hospitals, and daycare centers. CARB has identified the following groups of individuals as the most likely to be affected by air pollution: the elderly over age 65, children under age 14, athletes, and persons with cardiovascular and chronic respiratory diseases such as asthma, emphysema, and bronchitis. The nearest existing sensitive

land use to the Project Site is a single-family residence located approximately 0.5 miles from the northeastern corner of the Project boundary.

Construction-Generated Air Contaminants

Construction of the Project would result in temporary, short-term proposed Project-generated emissions of diesel particulate matter (DPM), ROG, NO_x, CO, and PM₁₀ from the exhaust of off-road, heavy-duty diesel equipment for Project construction; soil hauling truck traffic; paving; and other miscellaneous activities. The portion of the SSAB which encompasses the Project Area is designated as a nonattainment area for federal O₃ and PM_{2.5} standards and is also a nonattainment area for the state standards for O₃ and PM₁₀ (CARB 2019). Thus, existing O₃ and PM₁₀ levels in the SSAB are at unhealthy levels during certain periods. However, as shown in Table 2-5, the Project would not exceed the ICAPCD significance thresholds for construction emissions.

The health effects associated with O₃ are generally associated with reduced lung function. Because the Project would not involve construction activities that would result in O₃ precursor emissions (ROG or NO_x) in excess of the ICAPCD thresholds, the Project is not anticipated to substantially contribute to regional O₃ concentrations and the associated health impacts.

CO tends to be a localized impact associated with congested intersections. In terms of adverse health effects, CO competes with oxygen, often replacing it in the blood, reducing the blood's ability to transport oxygen to vital organs. The results of excess CO exposure can include dizziness, fatigue, and impairment of central nervous system functions. The Project would not involve activities that would result in CO emissions in excess of the ICAPCD thresholds. Thus, the Project's CO emissions would not contribute to the health effects associated with this pollutant.

Particulate matter (PM₁₀ and PM_{2.5}) contains microscopic solids or liquid droplets that are so small that they can get deep into the lungs and cause serious health problems. Particulate matter exposure has been linked to a variety of problems, including premature death in people with heart or lung disease, nonfatal heart attacks, irregular heartbeat, aggravated asthma, decreased lung function, and increased respiratory symptoms such as irritation of the airways, coughing, or difficulty breathing. For construction-type activity, DPM is the primary TAC of concern. PM₁₀ exhaust is considered a surrogate for DPM as all diesel exhaust is considered to be DPM. Most PM₁₀ exhaust derives from combustion, such as use of gasoline and diesel fuels by motor vehicles. As with O₃ and NO_x, the Project would not generate emissions of PM₁₀ or PM_{2.5} that would exceed the ICAPCD's thresholds. Accordingly, the Project's PM₁₀ and PM_{2.5} emissions are not expected to cause any increase in related regional health effects for these pollutants.

In summary, Project construction would not result in a potentially significant contribution to regional concentrations of nonattainment pollutants and would not result in a significant contribution to the adverse health impacts associated with those pollutants.

Operational Air Contaminants

Operation of the Proposed Project would not result in the development of any substantial sources of air toxics. There would be no stationary sources associated Project operations; nor would the Project attract

additional mobile sources that spend long periods queuing and idling at the site. Onsite Project emissions would not result in significant concentrations of pollutants at the nearby sensitive receptor as the predominant operational emissions associated with the Proposed Project would be routine maintenance work, water deliveries, and site security. Therefore, the Project would not be a substantial source of TACs. The Project will not result in a high carcinogenic or non-carcinogenic risk during operation.

Carbon Monoxide Hot Spots

It has long been recognized that CO exceedances are caused by vehicular emissions, primarily when idling at intersections. Concentrations of CO are a direct function of the number of vehicles, length of delay, and traffic flow conditions. Under certain meteorological conditions, CO concentrations close to congested intersections that experience high levels of traffic and elevated background concentrations may reach unhealthy levels, affecting nearby sensitive receptors. Given the high traffic volume potential, areas of high CO concentrations, or "hot spots," are typically associated with intersections that are projected to operate at unacceptable levels of service during the peak commute hours. It has long been recognized that CO hotspots are caused by vehicular emissions, primarily when idling at congested intersections. However, transport of this criteria pollutant is extremely limited, and CO disperses rapidly with distance from the source under normal meteorological conditions. Furthermore, vehicle emissions standards have become increasingly more stringent in the last 20 years. Currently, the allowable CO emissions standard in California is a maximum of 3.4 grams/mile for passenger cars (there are requirements for certain vehicles that are more stringent). With the turnover of older vehicles, introduction of cleaner fuels, and implementation of increasingly sophisticated and efficient emissions control technologies, CO concentration in the SSAB is designated as an attainment area. Detailed modeling of Project-specific CO "hot spots" is not necessary and thus this potential impact is addressed qualitatively.

A CO "hot spot" would occur if an exceedance of the state one-hour standard of 20 parts per million (ppm) or the eight-hour standard of 9 ppm were to occur. The analysis prepared for CO attainment in the South Coast Air Quality Management District's (SCAQMD's) *1992 Federal Attainment Plan for Carbon Monoxide* in Los Angeles County and a Modeling and Attainment Demonstration prepared by the SCAQMD as part of the 2003 Air Quality Management Plan can be used to demonstrate the potential for CO exceedances of these standards. The SCAQMD is the air pollution control officer for much of southern California. The SCAQMD conducted a CO hot spot analysis as part of the 1992 CO Federal Attainment Plan at four busy intersections in Los Angeles County during the peak morning and afternoon time periods. The intersections evaluated included Long Beach Boulevard and Imperial Highway (Lynwood), Wilshire Boulevard and Veteran Avenue (Westwood), Sunset Boulevard and Highland Avenue (Hollywood), and La Cienega Boulevard and Century Boulevard (Inglewood). The busiest intersection evaluated was at Wilshire Boulevard and Veteran Avenue, which has a traffic volume of approximately 100,000 vehicles per day. Despite this level of traffic, the CO analysis concluded that there was no violation of CO standards (SCAQMD 1992). In order to establish a more accurate record of baseline CO concentrations, a CO "hot spot" analysis was conducted in 2003 at the same four busy intersections in Los Angeles at the peak morning and afternoon time periods. This "hot spot" analysis did not predict any violation of CO standards. The highest one-hour concentration was measured at 4.6 ppm at Wilshire Boulevard and Veteran Avenue and the highest eight-hour concentration

was measured at 8.4 ppm at Long Beach Boulevard and Imperial Highway. Thus, there was no violation of CO standards.

Similar considerations are also employed by other Air Districts when evaluating potential CO concentration impacts. More specifically, the Bay Area Air Quality Management District (BAAQMD), the air pollution control officer for the San Francisco Bay Area, concludes that under existing and future vehicle emission rates, a given project would have to increase traffic volumes at a single intersection by more than 44,000 vehicles per hour or 24,000 vehicles per hour where vertical and/or horizontal air does not mix—in order to generate a significant CO impact.

The Proposed Project is anticipated to result in no more than 6 daily traffic trips. It is noted that this is a conservative estimate, and many days will have no operational related vehicle trips. Thus, the Proposed Project would not generate traffic volumes at any intersection of more than 100,000 vehicles per day (or 44,000 vehicles per day) and there is no likelihood of the Project traffic exceeding CO values.

2.3.3.5 Odors

Typically, odors are regarded as an annoyance rather than a health hazard. However, manifestations of a person's reaction to foul odors can range from psychological (e.g., irritation, anger, or anxiety) to physiological (e.g., circulatory and respiratory effects, nausea, vomiting, and headache).

With respect to odors, the human nose is the sole sensing device. The ability to detect odors varies considerably among the population and overall is quite subjective. Some individuals have the ability to smell minute quantities of specific substances; others may not have the same sensitivity but may have sensitivities to odors of other substances. In addition, people may have different reactions to the same odor; in fact, an odor that is offensive to one person (e.g., from a fast-food restaurant) may be perfectly acceptable to another. It is also important to note that an unfamiliar odor is more easily detected and is more likely to cause complaints than a familiar one. This is because of the phenomenon known as odor fatigue, in which a person can become desensitized to almost any odor and recognition only occurs with an alteration in the intensity.

Quality and intensity are two properties present in any odor. The quality of an odor indicates the nature of the smell experience. For instance, if a person describes an odor as flowery or sweet, then the person is describing the quality of the odor. Intensity refers to the strength of the odor. For example, a person may use the word "strong" to describe the intensity of an odor. Odor intensity depends on the odorant concentration in the air. When an odorous sample is progressively diluted, the odorant concentration decreases. As this occurs, the odor intensity weakens and eventually becomes so low that the detection or recognition of the odor is quite difficult. At some point during dilution, the concentration of the odorant reaches a detection threshold. An odorant concentration below the detection threshold means that the concentration in the air is not detectable by the average human.

During construction, the Proposed Project presents the potential for generation of objectionable odors in the form of diesel exhaust in the immediate vicinity of the site. However, these emissions are short-term in nature and will rapidly dissipate and be diluted by the atmosphere downwind of the emission sources. Additionally, odors would be localized and generally confined to the Project Area, which is generally devoid

of surrounding receptors. Therefore, odors generated during Project construction would not adversely affect a substantial number of people to odor emissions.

Land uses commonly considered to be potential sources of obnoxious odorous emissions include agriculture (farming and livestock), wastewater treatment plants, food processing plants, chemical plants, composting facilities, refineries, landfills, dairies, and fiberglass molding. The Proposed Project does not include any uses identified as being associated with odors.

3.0 GREENHOUSE GAS EMISSIONS

3.1 Greenhouse Gas Setting

Certain gases in the earth's atmosphere, classified as GHGs, play a critical role in determining the earth's surface temperature. Solar radiation enters the earth's atmosphere from space. A portion of the radiation is absorbed by the earth's surface and a smaller portion of this radiation is reflected back toward space. This absorbed radiation is then emitted from the earth as low-frequency infrared radiation. The frequencies at which bodies emit radiation are proportional to temperature. Because the earth has a much lower temperature than the sun, it emits lower-frequency radiation. Most solar radiation passes through GHGs; however, infrared radiation is absorbed by these gases. As a result, radiation that otherwise would have escaped back into space is instead trapped, resulting in a warming of the atmosphere. This phenomenon, known as the greenhouse effect, is responsible for maintaining a habitable climate on earth. Without the greenhouse effect, the earth would not be able to support life as we know it.

Prominent GHGs contributing to the greenhouse effect are CO₂, methane (CH₄), and N₂O. Fluorinated gases also make up a small fraction of the GHGs that contribute to climate change. Fluorinated gases include chlorofluorocarbons, hydrofluorocarbons, perfluorocarbons, sulfur hexafluoride, and nitrogen trifluoride; however, it is noted that these gases are not associated with typical land use development. Human-caused emissions of these GHGs in excess of natural ambient concentrations are believed to be responsible for intensifying the greenhouse effect and leading to a trend of unnatural warming of the earth's climate, known as global climate change or global warming. It is "extremely likely" that more than half of the observed increase in global average surface temperature from 1951 to 2010 was caused by the anthropogenic increase in GHG concentrations and other anthropogenic factors together (Intergovernmental Panel on Climate Change [IPCC] 2014).

Table 3-1 describes the primary GHGs attributed to global climate change, including their physical properties, primary sources, and contributions to the greenhouse effect.

Each GHG differs in its ability to absorb heat in the atmosphere based on the lifetime, or persistence, of the gas molecule in the atmosphere. CH₄ traps over 25 times more heat per molecule than CO₂, and N₂O absorbs 298 times more heat per molecule than CO₂ (IPCC 2014). Often, estimates of GHG emissions are presented in carbon dioxide equivalents (CO₂e), which weight each gas by its global warming potential. Expressing GHG emissions in CO₂e takes the contribution of all GHG emissions to the greenhouse effect and converts them to a single unit equivalent to the effect that would occur if only CO₂ were being emitted.

Climate change is a global problem. GHGs are global pollutants, unlike criteria air pollutants and TACs, which are pollutants of regional and local concern. Whereas pollutants with localized air quality effects have relatively short atmospheric lifetimes (about one day), GHGs have long atmospheric lifetimes (one to several thousand years). GHGs persist in the atmosphere for long enough time periods to be dispersed around the globe. Although the exact lifetime of any particular GHG molecule is dependent on multiple variables and cannot be pinpointed, it is understood that more CO₂ is emitted into the atmosphere than is sequestered by ocean uptake, vegetation, or other forms. Of the total annual human-caused CO₂ emissions, approximately 55 percent is sequestered through ocean and land uptakes every year, averaged over the

last 50 years, whereas the remaining 45 percent of human-caused CO₂ emissions remains stored in the atmosphere (IPCC 2013).

Table 3-1. Greenhouse Gases	
Greenhouse Gas	Description
CO ₂	Carbon dioxide is a colorless, odorless gas. CO ₂ is emitted in a number of ways, both naturally and through human activities. The largest source of CO ₂ emissions globally is the combustion of fossil fuels such as coal, oil, and gas in power plants, automobiles, industrial facilities, and other sources. A number of specialized industrial production processes and product uses such as mineral production, metal production, and the use of petroleum-based products can also lead to CO ₂ emissions. The atmospheric lifetime of CO ₂ is variable because it is so readily exchanged in the atmosphere. ¹
CH ₄	Methane is a colorless, odorless gas and is the major component of natural gas, about 87 percent by volume. It is also formed and released to the atmosphere by biological processes occurring in anaerobic environments. Methane is emitted from a variety of both human-related and natural sources. Human-related sources include fossil fuel production, animal husbandry (intestinal fermentation in livestock and manure management), rice cultivation, biomass burning, and waste management. These activities release significant quantities of CH ₄ to the atmosphere. Natural sources of CH ₄ include wetlands, gas hydrates, permafrost, termites, oceans, freshwater bodies, non-wetland soils, and other sources such as wildfires. The atmospheric lifetime of CH ₄ is about 12 years. ²
N ₂ O	Nitrous oxide is a clear, colorless gas with a slightly sweet odor. Nitrous oxide is produced by both natural and human-related sources. Primary human-related sources of N ₂ O are agricultural soil management, animal manure management, sewage treatment, mobile and stationary combustion of fossil fuels, adipic acid production, and nitric acid production. N ₂ O is also produced naturally from a wide variety of biological sources in soil and water, particularly microbial action in wet tropical forests. The atmospheric lifetime of N ₂ O is approximately 120 years. ³

Sources: ¹USEPA 2016a, ²USEPA 2016b, ³USEPA 2016c

The quantity of GHGs that it takes to ultimately result in climate change is not precisely known; it is sufficient to say the quantity is enormous, and no single project alone would measurably contribute to a noticeable incremental change in the global average temperature or to global, local, or microclimates. From the standpoint of CEQA, GHG impacts to global climate change are inherently cumulative.

3.1.1 Sources of Greenhouse Gas Emissions

In 2021, CARB released the 2021 edition of the California GHG inventory covering calendar year 2019 emissions. In 2019, California emitted 418.2 million gross metric tons of CO₂e including from imported electricity. Combustion of fossil fuel in the transportation sector was the single largest source of California's GHG emissions in 2019, accounting for approximately 40 percent of total GHG emissions in the State. When emissions from extracting, refining and moving transportation fuels in California are included, transportation is responsible for over 50 percent of statewide emissions in 2019. Continuing the downward trend from 2018, transportation emissions decreased 3.5 million metric tons of CO₂e in 2019, only being outpaced by electricity, which reduced emissions by 4.3 million metric tons of CO₂e in 2019. Emissions from

the electricity sector account for 14 percent of the inventory and have shown a substantial decrease in 2019 due to increases in renewables. California's industrial sector accounts for the second largest source of the State's GHG emissions in 2019, accounting for 21 percent (CARB 2021b).

3.2 Regulatory Framework

3.2.1 State

3.2.1.1 Executive Order S-3-05

Executive Order (EO) S-3-05, signed by Governor Arnold Schwarzenegger in 2005, proclaims that California is vulnerable to the impacts of climate change. It declares that increased temperatures could reduce the Sierra Nevada snowpack, further exacerbate California's air quality problems, and potentially cause a rise in sea levels. To combat those concerns, the EO established total GHG emission targets for the state. Specifically, emissions are to be reduced to the 2000 level by 2010, the 1990 level by 2020, and to 80 percent below the 1990 level by 2050.

3.2.1.2 Assembly Bill 32 Climate Change Scoping Plan and Updates

In 2006, the California legislature passed Assembly Bill (AB) 32 (Health and Safety Code § 38500 et seq., or AB 32), also known as the Global Warming Solutions Act. AB 32 required CARB to design and implement feasible and cost-effective emission limits, regulations, and other measures, such that statewide GHG emissions are reduced to 1990 levels by 2020 (representing a 25 percent reduction in emissions). Pursuant to AB 32, CARB adopted a Scoping Plan in December 2008, which outlined measures to meet the 2020 GHG reduction goals. California exceeded the target of reducing GHG emissions to 1990 levels by the year 2017.

The Scoping Plan is required by AB 32 to be updated at least every five years. The latest update, the 2017 Scoping Plan Update, addresses the 2030 target established by Senate Bill (SB) 32 as discussed below and establishes a proposed framework of action for California to meet a 40 percent reduction in GHG emissions by 2030 compared to 1990 levels. The key programs that the Scoping Plan Update builds on include increasing the use of renewable energy in the State, the Cap-and-Trade Regulation, the Low Carbon Fuel Standard, and reduction of methane emissions from agricultural and other wastes.

3.2.1.3 Senate Bill 32 and Assembly Bill 197 of 2016

In August 2016, Governor Brown signed SB 32 and AB 197, which serve to extend California's GHG reduction programs beyond 2020. SB 32 amended the Health and Safety Code to include § 38566, which contains language to authorize CARB to achieve a statewide GHG emission reduction of at least 40 percent below 1990 levels by no later than December 31, 2030.

3.2.1.4 Senate Bill 100 of 2018

In 2018, SB 100 was signed by Governor Brown, codifying a goal of 60 percent renewable procurement by 2030 and 100 percent by 2045 Renewables Portfolio Standard.

3.3 Greenhouse Gas Emissions Impact Assessment

3.3.1 Thresholds of Significance

The impact analysis provided below is based on the following CEQA Guidelines Appendix G thresholds of significance. The Project would result in a significant impact to GHG emissions if it would:

1. Generate GHG emissions, either directly or indirectly, that may have a significant impact on the environment.
2. Conflict with any applicable plan, policy, or regulation of an agency adopted for the purpose of reducing the emissions of greenhouse gases.

The Appendix G thresholds for GHG's do not prescribe specific methodologies for performing an assessment, do not establish specific thresholds of significance, and do not mandate specific mitigation measures. Rather, the CEQA Guidelines emphasize the lead agency's discretion to determine the appropriate methodologies and thresholds of significance consistent with the manner in which other impact areas are handled in CEQA. With respect to GHG emissions, the CEQA Guidelines § 15064.4(a) states that lead agencies "shall make a good-faith effort, based to the extent possible on scientific and factual data, to describe, calculate or estimate" GHG emissions resulting from a project. The CEQA Guidelines note that an agency has the discretion to either quantify a project's GHG emissions or rely on a "qualitative analysis or other performance-based standards." (14 California Code of Regulations [CCR] 15064.4(b)). A lead agency may use a "model or methodology" to estimate GHG emissions and has the discretion to select the model or methodology it considers "most appropriate to enable decision makers to intelligently take into account the project's incremental contribution to climate change." (14 CCR 15064.4(c)). Section 15064.4(b) provides that the lead agency should consider the following when determining the significance of impacts from GHG emissions on the environment:

1. The extent a project may increase or reduce GHG emissions as compared to the existing environmental setting.
2. Whether the project emissions exceed a threshold of significance that the lead agency determines applies to the project.
3. The extent to which the project complies with regulations or requirements adopted to implement a statewide, regional, or local plan for the reduction or mitigation of GHG emissions (14 CCR 15064.4(b)).

In addition, Section 15064.7(c) of the CEQA Guidelines specifies that "[w]hen adopting or using thresholds of significance, a lead agency may consider thresholds of significance previously adopted or recommended by other public agencies, or recommended by experts, provided the decision of the lead agency to adopt such thresholds is supported by substantial evidence" (14 CCR 15064.7(c)). The CEQA Guidelines also clarify that the effects of GHG emissions are cumulative and should be analyzed in the context of CEQA's requirements for cumulative impact analysis (see CEQA Guidelines § 15130(f)). As a note, the CEQA Guidelines were amended in response to SB 97. In particular, the CEQA Guidelines were amended to specify that compliance with a GHG emissions reduction plan renders a cumulative impact insignificant.

Per CEQA Guidelines § 15064(h)(3), a project's incremental contribution to a cumulative impact can be found not cumulatively considerable if the project would comply with an approved plan or mitigation program that provides specific requirements that would avoid or substantially lessen the cumulative problem within the geographic area of the project. To qualify, such plans or programs must be specified in law or adopted by the public agency with jurisdiction over the affected resources through a public review process to implement, interpret, or make specific the law enforced or administered by the public agency. Examples of such programs include a "water quality control plan, air quality attainment or maintenance plan, integrated waste management plan, habitat conservation plan, natural community conservation plans [and] plans or regulations for the reduction of greenhouse gas emissions." Put another way, CEQA Guidelines § 15064(h)(3) allows a lead agency to make a finding of less than significant for GHG emissions if a project complies with adopted programs, plans, policies and/or other regulatory strategies to reduce GHG emissions.

The significance of the Project's GHG emissions is evaluated consistent with CEQA Guidelines § 15064.4(b)(2) by considering whether the Project complies with applicable plans, policies, regulations and requirements adopted to implement a statewide, regional, or local plan for the reduction or mitigation of GHG emissions. The ICAPCD has not adopted a GHG significance threshold yet recommends the 100,000-metric ton of CO₂e threshold established by the Mojave Desert Air Quality Management District (MDAQMD). As previously described, Section 15064.7(c) of the CEQA Guidelines specifies that "[w]hen adopting or using thresholds of significance, a lead agency may consider thresholds of significance previously adopted or recommended by other public agencies, or recommended by experts, provided the decision of the lead agency to adopt such thresholds is supported by substantial evidence" (14 CCR 15064.7(c)). This ICAPCD-recommended threshold is appropriate as the MDAQMD GHG thresholds were formulated based on similar geography and climate patterns as found in Imperial County. Therefore, the 100,000-metric ton of CO₂e threshold is appropriate for this analysis.

In *Center for Biological Diversity v. Department of Fish and Wildlife* (2015) 62 Cal. 4th 2014, 213, 221, 227, following its review of various potential GHG thresholds proposed in an academic study [Crockett, *Addressing the Significance of Greenhouse Gas Emissions: California's Search for Regulatory Certainty in an Uncertain World* (July 2011), 4 Golden Gate U. Env'tl. L. J. 203], the California Supreme Court identified the use of numeric bright-line thresholds as a potential pathway for compliance with CEQA GHG requirements. The study found numeric bright line thresholds designed to determine when small projects were so small as to not cause a cumulatively considerable impact on global climate change was consistent with CEQA. Specifically, Public Resources Code section 21003(f) provides it is a policy of the state that "[a]ll persons and public agencies involved in the environmental review process be responsible for carrying out the process in the most efficient, expeditious manner in order to conserve the available financial, governmental, physical and social resources with the objective that those resources may be better applied toward the mitigation of actual significant effects on the environment." The Supreme Court-reviewed study noted, "[s]ubjecting the smallest projects to the full panoply of CEQA requirements, even though the public benefit would be minimal, would not be consistent with implementing the statute in the most efficient, expeditious manner. Nor would it be consistent with applying lead agencies' scarce resources toward mitigating actual significant climate change impacts." (Crockett, *Addressing the Significance of Greenhouse Gas Emissions: California's Search for Regulatory Certainty in an Uncertain World* (July 2011), 4 Golden Gate U. Env'tl. L. J. 203, 221, 227.)

3.3.2 Methodology

GHG-related impacts were assessed in accordance with methodologies recommended by the ICAPCD. Where GHG emission quantification was required, emissions were modeled using CalEEMod, version 2020.4.0. CalEEMod is a statewide land use emissions computer model designed to quantify potential GHG emissions associated with both construction and operations from a variety of land use projects. Project construction-generated GHG emissions were calculated using CalEEMod model defaults for Imperial County coupled with information provided by the Project applicant. For instance, as described in the Section 1.2, Project Overview, construction activities would primarily involve demolition and grubbing, grading of the Project Site to establish access roads and pads for electrical equipment, trenching for underground electrical collection lines, and the installation of solar equipment and security fencing. Construction is estimated to take 12-18 months and would begin in late 2022 or 2023. The number of on-site construction workers for the solar facility is not expected to exceed 150 workers at any time. The number of on-site construction workers for the BESS and substation is not expected to exceed 100 workers at any one time. According to the Traffic Study prepared for the Project (KOA 2020), Project construction would generate a maximum of 500 construction worker-commute trips in a single day.

Operational GHG emissions account for the maximum three workers visiting the site in a single day. Such visits include inspections, equipment servicing, site and landscape clearing, and periodic washing of the PV modules if needed (up to two times per year) to maintain power generation efficiency. Therefore, operational onsite equipment use is accounted in addition to the consumption of 10 acre-feet (3,259,000 gallons) of water annually.

3.3.3 Impact Analysis

3.3.3.1 Generation of GHG Emissions

Project Construction

Construction-related activities that would generate GHG emissions include worker commute trips, haul trucks carrying supplies and materials to and from the project site, and off-road construction equipment (e.g., dozers, loaders, excavators). Table 3-2 illustrates the specific construction generated GHG emissions that would result from construction of the Project. Consistent with SCAQMD recommendations, Project construction GHG emissions have been amortized over the expected life of the Project, which is considered to be 30 years for a solar energy generation facility. Once construction is complete, the generation of these GHG emissions would cease.

Table 3-2. Construction-Related Greenhouse Gas Emissions	
Emissions Source	CO₂e (Metric Tons/Year)
Construction Year One	913
Construction Year Two	611
<i>Significance Threshold</i>	<i>100,000</i>
<i>Exceed Significance Threshold?</i>	No

Source: CalEEMod version 2020.4.0. Refer to Attachment C for Model Data Outputs.

As shown in Table 3-2, Project would result in the generation of approximately 913 metric tons of CO₂e in the first calendar year of construction and 611 metric tons in the second calendar year of construction. Therefore, Project GHG emissions would not exceed the significance threshold.

Additionally, the Project proposes a solar energy generation facility intended to generate renewable energy. Solar plants generate far less GHG life-cycle emissions (approximately 83 to 94 percent less) than fossil-fueled energy plants. As identified in Table 3-5 below, the Project would potentially displace approximately 53,220 metric tons of CO₂e per year, and approximately 1,596,596 metric tons of CO₂e over the course of 30 years, which is considerably more than would be generated during construction.

Operations

Operation of the Project would result in an increase in GHG emissions. Long-term GHG emissions attributed to operations of the Project are identified in Table 3-3.

Table 3-3. Operational-Related Greenhouse Gas Emissions	
Emission Source	CO₂e (Metric Tons/ Year)
Area Source	0
Energy	1,088
Mobile	7
Offroad Equipment	8
Waste	82
Water	8
Total	1,194
Significance Threshold	100,000
Exceed Significance Threshold?	No

Source: CalEEMod version 2020.4.0. Refer to Attachment C for Model Data Outputs.

As shown in Table 3-3, operational-generated emissions would generate approximately 1,194 metric tons of GHG emissions and not exceed the significance threshold of 100,000 metric tons of CO₂e annually. As shown in Table 3-3, the majority of emissions are attributable to indirect energy consumption. The BESS component of the Project was modeled to account for HVAC use. However, this is potentially a conservative estimate since the energy source for the BESS HVAC could include the solar energy generated by the Project itself, which would be an emissions-free source of energy.

3.3.3.2 Conflict with any Applicable Plan, Policy, or Regulation of an Agency Adopted for the Purpose of Reducing the Emissions of Greenhouse Gases

The Project would not conflict with any adopted plans, policies, or regulations adopted for the purpose of reducing GHG emissions. The Proposed Project is subject to compliance with SB 32. As discussed previously, the Proposed Project-generated GHG emissions would not surpass either the ICAPCD-recommended GHG significance threshold, which was prepared with the purpose of complying with statewide GHG-reduction efforts. Additionally, once construction is complete, the Project would be a producer of renewable energy, which generates substantially less GHG emissions compared with the more common types of fossil-fueled energy generation facilities.

GHG emissions generated by energy sources account for all stages of the life cycle (including mining, construction, etc.), which are referred to as the cumulative GHG emissions and are usually expressed in grams of CO₂e per unit of busbar electricity (i.e., gCO₂/kWh_e). When comparing various fossil-fueled energy generators, the GHG emissions generated are dependent on the type of fuel (i.e., gas, oil, coal). GHG emissions generated by some of the more common types of fossil-fueled plants and solar-power plants are summarized in Table 3-4.

Table 3-4. Life-Cycle Greenhouse Gas Emissions for Various Types of Energy Generators	
Fossil Fueled	
Coal	950 to 1,250 gCO ₂ e/kWhe
Oil	500 to 1,200 gCO ₂ e/kWhe
Gas	440 to 780 gCO ₂ e/kWhe
Solar	43 to 73 ³ gCO ₂ e/kWhe

Source: Weisser 2007

Notes:

1 gCO₂e/kWhe = grams of CO₂e per unit of busbar electricity.

2 Emissions are based on lifecycle of energy source including mining, construction, operation, etc.

3 Solar PV life-cycle emissions result from using fossil-fuel-based energy to produce the materials for solar cells, modules, and systems, as well as directly from smelting, production, and manufacturing facilities.

As shown in Table 3-4, solar plants generate far less GHG life-cycle emissions (approximately 83 to 94 percent less) than fossil-fueled energy plants. Therefore, the Proposed Project would contribute to the continued reduction of GHG emissions in the interconnected California and western U.S. electricity systems, as the energy produced by the Project would displace GHG emissions that would otherwise be produced by existing business-as-usual power generation resources (including natural gas, coal, arid renewable combustion resources).

Table 3-5 shows the emissions that would potentially be displaced by the Proposed Project. Note that this estimate only includes that associated with the combustion of fossil fuels; it does not include the vehicle trips associated with the Project's operations, and it similarly does not include operational employee trips associated with natural gas or coal combustion nor the emissions associated with extracting and transporting those power sources. In addition, this estimate only includes the displacement of that portion of the California market that comes from fossil fuels and does not include the approximate 50 percent of the California electricity generated by non-combustion sources (wind, solar, nuclear, hydro-electric) (CEC 2020).

Table 3-5. Proposed Project Displaced GHG Emissions (Metric Tons)				
	Emissions (Metric Tons)			
	CO₂	CH₄	N₂O	CO₂e
Emissions Displaced Annually (metric tons)				
Displaced Natural Gas-Source Emissions	47,585	0.00	0.00	47,585
Displaced Coal-Source Emissions	5,626	0.037	0.028	5,635
Total	53,210	0.037	0.028	53,220
Emissions Displaced over 30 Years (metric tons)				
Total	1,596,309	1.118	0.838	1,596,596

Source: Displaced emissions calculated by ECORP using USEPA's AP-42 Fifth Edition Compilation of Air Emissions Factors 1995; 2015. See Attachment B.

Notes: In order to provide a conservative analysis, the proposed Project is assumed to generate electricity 25 percent of the time available (2,190 hours annually). Heat Rate indicates the energy generator efficiency of existing fossil-fuel based energy generators. The heat rate of a power plant measures the amount of fuel used to generate one unit of electricity. Power plants with lower heat rates are more efficient than plants with higher heat rates. The CEC's "Updated Thermal Power Plant Efficiency Measures and Operational Characteristics for Production Cost Modeling" (2019) estimates heat rates and operating ranges for thermal power plants supplying energy to California. The average heat rate of power plants types are as follows:

**Steam Boiler fueled by coal: 10,800 heat rate **Steam Boiler fueled by natural gas: 10,200 heat rate **Gas Turbine: 10,100 heat rate **Combined natural gas Boiler and Turbine: 7,640 heat rate.

By omitting steam boilers fueled by coal since so little of California's energy is derived from coal, the average heat rate = 9,313 $[(10,100 + 10,200 + 7,640) \div 3 = 9,313]$. 100 MW (219,000,000 annual kWh) x 9,313 heat rate = 2,039,547,000,000 Btu displaced from fossil fuel production. Fossil fuel-based energy consumption in California is predominately derived from natural gas (37.06 percent). Coal constitutes 2.74 percent of all fossil fuel-based energy. Therefore, 865,175,837,400 of the displaced Btu is displaced natural gas and unspecified nonrenewable sources consumption and 55,883,587,800 of the displaced Btu is displaced coal. The heat content of coal is assumed at 24 million Btu per ton of coal burned. At a rate of 24 million Btu per ton of coal burned, the Project would displace 2,328 tons of burned coal annually.

As shown, the Project would potentially displace approximately 53,220 metric tons of CO₂e per year, and approximately 1,596,596 metric tons of CO₂e over the course of 30 years.

While the Project would emit some GHG emissions during construction and a small amount during operations, the contribution of renewable resource energy production to meet the goals of the Renewable Portfolio Standard (Scoping Plan Measure E-3) would result in a net cumulative reduction of GHG emissions, a key environmental benefit. (Scoping Plan Measure E-3, Renewable Portfolio Standard, of the Climate Change Scoping Plan requires that all investor-owned utility companies generate 60 percent of their energy demand from renewable sources by year 2030.) Therefore, the short-term minor generation of GHG emissions during construction, which is necessary to create this new, low-GHG-emitting power-generating facility, as well as the negligible amount generated during ongoing maintenance operations, would be more than offset by GHG emission reductions associated with solar-generated energy during operation.

Increasing sources of solar energy is one of the measures identified under the Scoping Plan to reduce statewide GHG emissions. The Proposed Project would reduce GHG emissions in a manner consistent with SB 32 and other California GHG-reducing legislation by creating a new source of solar power to replace the current use of fossil-fuel power and reduce GHG emissions power generation and use.

The Project would not conflict with any applicable plan, policy, or regulation intended to reduce GHG emissions.

4.0 REFERENCES

- California Air Pollution Control Officers Association (CAPCOA). 2021. California Emissions Estimator Model (CalEEMod), version 2020.4.0.
- _____. 2013. Health Effects. <http://www.capcoa.org/health-effects/>.
- California Air Resources Board (CARB). 2021a. Air Quality Data Statistics. <http://www.arb.ca.gov/adam/index.html>.
- _____. 2021b. California Greenhouse Gas Emission Inventory 2021 Edition.
- _____. 2020b. Air Quality and Land Use Handbook
- _____. 2019. State and Federal Area Designation Maps. <http://www.arb.ca.gov/desig/adm/adm.htm>.
- California Energy Commission (CEC). 2020. 2020 Total System Electric Generation. <https://www.energy.ca.gov/data-reports/energy-almanac/california-electricity-data/2020-total-system-electric-generation>
- _____. 2019b. Updated Thermal Power Plant Efficiency Measures and Operational Characteristics for Production Cost Modeling.
- Crockett, Alexander G. 2011. Addressing the Significance of Greenhouse Gas Emissions Under CEQA: California's Search for Regulatory Certainty in an Uncertain World.
- Intergovernmental Panel on Climate Change (IPCC). 2014. Climate Change 2014 Synthesis Report: Approved Summary for Policymakers. <http://www.ipcc.ch/>.
- _____. 2013. Carbon and Other Biogeochemical Cycles. In: Climate Change 2013: The Physical Science Basis. Contribution of Working Group I to the Fifth Assessment Report of the Intergovernmental Panel on Climate Change. http://www.climatechange2013.org/images/report/WG1AR5_ALL_FINAL.pdf.
- Imperial County Air Pollution Control District (ICAPCD). 2021. Email communication with Monica Soucier.
- _____. 2017. *Air Quality Handbook*.
- _____. 2010. *Final 2009 1997 8-Hour Ozone Modified Air Quality Management Plan*.
- KOA. 2020. Scoping Memorandum for Traffic Impact Study.
- South Coast Air Quality Management District (SCAQMD). 2003. Air Quality Management Plan.
- _____. 1992. 1992 Federal Attainment Plan for Carbon Monoxide.
- U.S. Environmental Protection Agency (USEPA). 2016a. Climate Change – Greenhouse Gas Emissions: Carbon Dioxide. <http://www.epa.gov/climatechange/emissions/co2.html>.
- _____. 2016b. Methane. <https://www3.epa.gov/climatechange/ghgemissions/gases/ch4.html>.

_____. 2016c. Nitrous Oxide. <https://www3.epa.gov/climatechange/ghgemissions/gases/n2o.html>.

_____. 2002. Health Assessment Document for Diesel Engine Exhaust.
<https://nepis.epa.gov/Exe/ZyPURL.cgi?Dockkey=300055PV.TXT>.

Weisser, Daniel. 2007. A Guide to Life-Cycle Greenhouse Gas (GHG) Emissions from Electric Supply Technologies. *Energy* 32 (9), 1543–1559.

LIST OF ATTACHMENTS

Attachment A – CalEEMod Output Files Criteria Air Pollutants

Attachment B – Renewable Energy Emissions Displacement

Attachment C – CalEEMod Output Files Greenhouse Gas Emissions

CalEEMod Output Files Criteria Air Pollutants

Vega SES 4 Solar Energy Storage Project - Imperial County, Summer

EMFAC Off-Model Adjustment Factors for Gasoline Light Duty Vehicle to Account for the SAFE Vehicle Rule Not Applied

**Vega SES 4 Solar Energy Storage Project
Imperial County, Summer**

1.0 Project Characteristics

1.1 Land Usage

Land Uses	Size	Metric	Lot Acreage	Floor Surface Area	Population
Other Non-Asphalt Surfaces	447.00	Acre	447.00	19,471,320.00	0
Refrigerated Warehouse-No Rail	87.12	1000sqft	2.00	87,120.00	0
Refrigerated Warehouse-No Rail	87.12	1000sqft	2.00	87,120.00	0
Other Non-Asphalt Surfaces	3.50	Acre	3.50	152,460.00	0

1.2 Other Project Characteristics

Urbanization	Rural	Wind Speed (m/s)	3.4	Precipitation Freq (Days)	12
Climate Zone	15			Operational Year	2023
Utility Company	Imperial Irrigation District				
CO2 Intensity (lb/MWhr)	189.98	CH4 Intensity (lb/MWhr)	0.033	N2O Intensity (lb/MWhr)	0.004

1.3 User Entered Comments & Non-Default Data

Project Characteristics -

Land Use - Land Uses account for 447 acres of solar field, 2 acres of BESS, 2 acres of Substation, and 3.5 acres of Staging/Parking Area

Construction Phase - Construction timing per Project Applicant

Off-road Equipment - Construction equipment per Project applicant. Plate compactor = pile driver.

Off-road Equipment - Ibid

Off-road Equipment - Construction equipment per Project applicant.

Trips and VMT - Maximun 500 worker commute trips per Traffic Study. 20.25 miles added to vendor route for extended access along border.

On-road Fugitive Dust - 89% paved roads for worker commutes [1.15 m dirt roads / 10.2 m trip length default = 89% paved roads]. Traffic Study identifies worker commute routes north of Staging/Parking Area as 100% paved. 37% paved for vendor/equipment hauling trips. Trips require additional 20.25 miles of distance on dirt roadway.

PC ORIGINAL PKG

Vega SES 4 Solar Energy Storage Project - Imperial County, Summer

EMFAC Off-Model Adjustment Factors for Gasoline Light Duty Vehicle to Account for the SAFE Vehicle Rule Not Applied

Grading -

Vehicle Trips - Maximum daily trips = 6 per Traffic Study

Road Dust - 92% paved roads for operational worker commutes [1.15 m dirt roads / 14.55 m trip length default weighted average = 92% paved roads].

Energy Use - Solar facility- no operational energy use.

Water And Wastewater - Water use being kept for light industrial land use as the solar panels may need to be cleaned.

Solid Waste - No solid waste- solar facility.

Construction Off-road Equipment Mitigation - Mitigation measure AQ-1 accounted. PM Reduction value for applying soil stabilizers to unpaved roadways per communication with ICAPCD (Monica Soucier via email correspondence).

Mobile Land Use Mitigation -

Energy Mitigation -

Operational Off-Road Equipment - Onsite maintenance expected 4 times annually.

Table Name	Column Name	Default Value	New Value
tblConstDustMitigation	WaterUnpavedRoadVehicleSpeed	40	15
tblConstructionPhase	NumDays	7,750.00	286.00
tblConstructionPhase	NumDays	775.00	66.00
tblConstructionPhase	NumDays	300.00	33.00
tblConstructionPhase	PhaseEndDate	9/30/2055	7/25/2024
tblConstructionPhase	PhaseEndDate	1/15/2026	6/21/2023
tblConstructionPhase	PhaseEndDate	1/26/2023	3/21/2023
tblConstructionPhase	PhaseStartDate	1/16/2026	6/22/2023
tblConstructionPhase	PhaseStartDate	1/27/2023	3/22/2023
tblConstructionPhase	PhaseStartDate	12/3/2021	2/3/2023
tblOffRoadEquipment	LoadFactor	0.36	0.36
tblOffRoadEquipment	LoadFactor	0.40	0.40
tblOffRoadEquipment	LoadFactor	0.42	0.42
tblOffRoadEquipment	LoadFactor	0.36	0.36
tblOffRoadEquipment	LoadFactor	0.50	0.50
tblOffRoadEquipment	LoadFactor	0.38	0.38
tblOffRoadEquipment	OffRoadEquipmentType	PC ORIGINAL PKG	Rubber Tired Loaders

Vega SES 4 Solar Energy Storage Project - Imperial County, Summer

EMFAC Off-Model Adjustment Factors for Gasoline Light Duty Vehicle to Account for the SAFE Vehicle Rule Not Applied

tblOffRoadEquipment	OffRoadEquipmentType		Rough Terrain Forklifts
tblOffRoadEquipment	OffRoadEquipmentType		Pavers
tblOffRoadEquipment	OffRoadEquipmentType		Paving Equipment
tblOffRoadEquipment	OffRoadEquipmentType		Plate Compactors
tblOffRoadEquipment	OffRoadEquipmentType		Trenchers
tblOffRoadEquipment	OffRoadEquipmentType		Rollers
tblOffRoadEquipment	OffRoadEquipmentUnitAmount	2.00	4.00
tblOffRoadEquipment	OffRoadEquipmentUnitAmount	3.00	0.00
tblOffRoadEquipment	OffRoadEquipmentUnitAmount	1.00	0.00
tblOffRoadEquipment	OffRoadEquipmentUnitAmount	1.00	3.00
tblOffRoadEquipment	OffRoadEquipmentUnitAmount	1.00	2.00
tblOffRoadEquipment	OffRoadEquipmentUnitAmount	3.00	0.00
tblOffRoadEquipment	OffRoadEquipmentUnitAmount	3.00	4.00
tblOffRoadEquipment	OffRoadEquipmentUnitAmount	2.00	4.00
tblOffRoadEquipment	OffRoadEquipmentUnitAmount	4.00	2.00
tblOffRoadEquipment	OffRoadEquipmentUnitAmount	1.00	0.00
tblOnRoadDust	VendorPercentPave	50.00	37.00
tblOnRoadDust	VendorPercentPave	50.00	37.00
tblOnRoadDust	VendorPercentPave	50.00	37.00
tblOnRoadDust	WorkerPercentPave	50.00	89.00
tblOnRoadDust	WorkerPercentPave	50.00	89.00
tblOnRoadDust	WorkerPercentPave	50.00	89.00
tblOperationalOffRoadEquipment	OperDaysPerYear	260.00	8.00
tblOperationalOffRoadEquipment	OperDaysPerYear	260.00	8.00
tblOperationalOffRoadEquipment	OperHoursPerDay	8.00	2.00
tblOperationalOffRoadEquipment	OperLoadFactor	0.42	0.42
tblOperationalOffRoadEquipment	OperLoadFactor	0.38	0.38
tblOperationalOffRoadEquipment	OperOffRoadEquipmentNumber	0.00	3.00
tblOperationalOffRoadEquipment	OperOffRoadEquipmentNumber	0.00	1.00

PC ORIGINAL PKG

Vega SES 4 Solar Energy Storage Project - Imperial County, Summer

EMFAC Off-Model Adjustment Factors for Gasoline Light Duty Vehicle to Account for the SAFE Vehicle Rule Not Applied

tblProjectCharacteristics	UrbanizationLevel	Urban	Rural
tblRoadDust	RoadPercentPave	50	92
tblTripsAndVMT	VendorTripLength	11.90	32.15
tblTripsAndVMT	VendorTripLength	11.90	32.15
tblTripsAndVMT	VendorTripLength	11.90	32.15
tblTripsAndVMT	VendorTripNumber	0.00	4.00
tblTripsAndVMT	VendorTripNumber	0.00	4.00
tblTripsAndVMT	VendorTripNumber	3,245.00	4.00
tblTripsAndVMT	WorkerTripNumber	8,315.00	500.00
tblVehicleTrips	ST_TR	2.12	0.00
tblVehicleTrips	SU_TR	2.12	0.00
tblVehicleTrips	WD_TR	2.12	0.03
tblWater	IndoorWaterUseRate	40,293,000.00	3,259,000.00

2.0 Emissions Summary

Vega SES 4 Solar Energy Storage Project - Imperial County, Summer

EMFAC Off-Model Adjustment Factors for Gasoline Light Duty Vehicle to Account for the SAFE Vehicle Rule Not Applied

2.1 Overall Construction (Maximum Daily Emission)

Unmitigated Construction

	ROG	NOx	CO	SO2	Fugitive PM10	Exhaust PM10	PM10 Total	Fugitive PM2.5	Exhaust PM2.5	PM2.5 Total	Bio- CO2	NBio- CO2	Total CO2	CH4	N2O	CO2e
Year	lb/day										lb/day					
2023	5.6636	57.6100	53.8307	0.1062	948.4182	2.3569	949.9344	95.2426	2.1685	96.6408	0.0000	10,324.71 67	10,324.71 67	3.1545	0.1515	10,419.20 84
2024	5.1830	30.0350	52.4623	0.0944	948.4182	1.4097	949.8279	95.2426	1.3002	96.5428	0.0000	9,265.731 2	9,265.731 2	1.8251	0.1426	9,353.850 8
Maximum	5.6636	57.6100	53.8307	0.1062	948.4182	2.3569	949.9344	95.2426	2.1685	96.6408	0.0000	10,324.71 67	10,324.71 67	3.1545	0.1515	10,419.20 84

Mitigated Construction

	ROG	NOx	CO	SO2	Fugitive PM10	Exhaust PM10	PM10 Total	Fugitive PM2.5	Exhaust PM2.5	PM2.5 Total	Bio- CO2	NBio- CO2	Total CO2	CH4	N2O	CO2e
Year	lb/day										lb/day					
2023	5.6636	57.6100	53.8307	0.1062	90.3461	2.3569	91.8623	9.6062	2.1685	11.0044	0.0000	10,324.71 67	10,324.71 67	3.1545	0.1515	10,419.20 84
2024	5.1830	30.0350	52.4623	0.0944	90.3461	1.4097	91.7558	9.6062	1.3002	10.9064	0.0000	9,265.731 2	9,265.731 2	1.8251	0.1426	9,353.850 8
Maximum	5.6636	57.6100	53.8307	0.1062	90.3461	2.3569	91.8623	9.6062	2.1685	11.0044	0.0000	10,324.71 67	10,324.71 67	3.1545	0.1515	10,419.20 84

Vega SES 4 Solar Energy Storage Project - Imperial County, Summer

EMFAC Off-Model Adjustment Factors for Gasoline Light Duty Vehicle to Account for the SAFE Vehicle Rule Not Applied

	ROG	NOx	CO	SO2	Fugitive PM10	Exhaust PM10	PM10 Total	Fugitive PM2.5	Exhaust PM2.5	PM2.5 Total	Bio- CO2	NBio-CO2	Total CO2	CH4	N2O	CO2e
Percent Reduction	0.00	0.00	0.00	0.00	90.47	0.00	90.33	89.91	0.00	88.66	0.00	0.00	0.00	0.00	0.00	0.00

2.2 Overall Operational

Unmitigated Operational

	ROG	NOx	CO	SO2	Fugitive PM10	Exhaust PM10	PM10 Total	Fugitive PM2.5	Exhaust PM2.5	PM2.5 Total	Bio- CO2	NBio- CO2	Total CO2	CH4	N2O	CO2e
Category	lb/day										lb/day					
Area	13.5919	5.8000e-004	0.0638	0.0000		2.3000e-004	2.3000e-004		2.3000e-004	2.3000e-004		0.1367	0.1367	3.6000e-004		0.1457
Energy	0.2663	2.4210	2.0337	0.0145		0.1840	0.1840		0.1840	0.1840		2,905.2168	2,905.2168	0.0557	0.0533	2,922.4811
Mobile	0.0294	0.0355	0.3113	6.4000e-004	4.8460	4.4000e-004	4.8464	0.4922	4.1000e-004	0.4927		64.8492	64.8492	2.6500e-003	2.7400e-003	65.7319
Offroad	1.1604	11.0968	12.7025	0.0217		0.5634	0.5634		0.5184	0.5184	0.0000	2,096.6998	2,096.6998	0.6781		2,113.6527
Total	15.0481	13.5539	15.1112	0.0368	4.8460	0.7481	5.5941	0.4922	0.7030	1.1952	0.0000	5,066.9026	5,066.9026	0.7368	0.0560	5,102.0114

Vega SES 4 Solar Energy Storage Project - Imperial County, Summer

EMFAC Off-Model Adjustment Factors for Gasoline Light Duty Vehicle to Account for the SAFE Vehicle Rule Not Applied

2.2 Overall Operational

Mitigated Operational

	ROG	NOx	CO	SO2	Fugitive PM10	Exhaust PM10	PM10 Total	Fugitive PM2.5	Exhaust PM2.5	PM2.5 Total	Bio- CO2	NBio- CO2	Total CO2	CH4	N2O	CO2e
Category	lb/day										lb/day					
Area	13.5919	5.8000e-004	0.0638	0.0000		2.3000e-004	2.3000e-004		2.3000e-004	2.3000e-004		0.1367	0.1367	3.6000e-004		0.1457
Energy	0.2663	2.4210	2.0337	0.0145		0.1840	0.1840		0.1840	0.1840		2,905.2168	2,905.2168	0.0557	0.0533	2,922.4811
Mobile	0.0294	0.0355	0.3113	6.4000e-004	4.8460	4.4000e-004	4.8464	0.4922	4.1000e-004	0.4927		64.8492	64.8492	2.6500e-003	2.7400e-003	65.7319
Offroad	1.1604	11.0968	12.7025	0.0217		0.5634	0.5634		0.5184	0.5184	0.0000	2,096.6998	2,096.6998	0.6781		2,113.6527
Total	15.0481	13.5539	15.1112	0.0368	4.8460	0.7481	5.5941	0.4922	0.7030	1.1952	0.0000	5,066.9026	5,066.9026	0.7368	0.0560	5,102.0114

	ROG	NOx	CO	SO2	Fugitive PM10	Exhaust PM10	PM10 Total	Fugitive PM2.5	Exhaust PM2.5	PM2.5 Total	Bio- CO2	NBio- CO2	Total CO2	CH4	N2O	CO2e
Percent Reduction	0.00	0.00	0.00	0.00	0.00	0.00	0.00	0.00	0.00	0.00	0.00	0.00	0.00	0.00	0.00	0.00

3.0 Construction Detail

Construction Phase

Phase Number	Phase Name	Phase Type	Start Date	End Date	Num Days Week	Num Days	Phase Description
1	Site Preparation	Site Preparation	2/3/2023	3/21/2023	5	33	
2	Grading	Grading	3/22/2023	6/21/2023	5	66	
3	Building Construction	Building Construction	6/22/2023	7/25/2024	5	286	

Acres of Grading (Site Preparation Phase): 0

PC ORIGINAL PKG

Vega SES 4 Solar Energy Storage Project - Imperial County, Summer

EMFAC Off-Model Adjustment Factors for Gasoline Light Duty Vehicle to Account for the SAFE Vehicle Rule Not Applied

Acres of Grading (Grading Phase): 297

Acres of Paving: 450.5

Residential Indoor: 0; Residential Outdoor: 0; Non-Residential Indoor: 0; Non-Residential Outdoor: 0; Striped Parking Area: 0 (Architectural Coating – sqft)

OffRoad Equipment

Phase Name	Offroad Equipment Type	Amount	Usage Hours	Horse Power	Load Factor
Site Preparation	Rubber Tired Dozers	0	8.00	247	0.40
Site Preparation	Tractors/Loaders/Backhoes	2	8.00	97	0.37
Grading	Excavators	4	8.00	158	0.38
Grading	Graders	3	8.00	187	0.41
Grading	Rubber Tired Dozers	2	8.00	247	0.40
Grading	Scrapers	2	8.00	367	0.48
Grading	Tractors/Loaders/Backhoes	4	8.00	97	0.37
Building Construction	Cranes	1	7.00	231	0.29
Building Construction	Forklifts	0	8.00	89	0.20
Building Construction	Generator Sets	0	8.00	84	0.74
Site Preparation	Rubber Tired Loaders	2	8.00	203	0.36
Building Construction	Rough Terrain Forklifts	4	8.00	100	0.40
Building Construction	Pavers	1	8.00	130	0.42
Building Construction	Tractors/Loaders/Backhoes	4	7.00	97	0.37
Building Construction	Paving Equipment	2	8.00	132	0.36
Building Construction	Welders	0	8.00	46	0.45
Building Construction	Plate Compactors	4	8.00	8	0.43
Building Construction	Trenchers	2	8.00	78	0.50
Building Construction	Rollers	2	8.00	80	0.38

Trips and VMT

Vega SES 4 Solar Energy Storage Project - Imperial County, Summer

EMFAC Off-Model Adjustment Factors for Gasoline Light Duty Vehicle to Account for the SAFE Vehicle Rule Not Applied

Phase Name	Offroad Equipment Count	Worker Trip Number	Vendor Trip Number	Hauling Trip Number	Worker Trip Length	Vendor Trip Length	Hauling Trip Length	Worker Vehicle Class	Vendor Vehicle Class	Hauling Vehicle Class
Site Preparation	4	10.00	4.00	0.00	10.20	32.15	20.00	LD_Mix	HDT_Mix	HHDT
Grading	15	38.00	4.00	0.00	10.20	32.15	20.00	LD_Mix	HDT_Mix	HHDT
Building Construction	20	500.00	4.00	0.00	10.20	32.15	20.00	LD_Mix	HDT_Mix	HHDT

3.1 Mitigation Measures Construction

- Use Soil Stabilizer
- Water Exposed Area
- Water Unpaved Roads
- Reduce Vehicle Speed on Unpaved Roads

3.2 Site Preparation - 2023

Unmitigated Construction On-Site

	ROG	NOx	CO	SO2	Fugitive PM10	Exhaust PM10	PM10 Total	Fugitive PM2.5	Exhaust PM2.5	PM2.5 Total	Bio- CO2	NBio- CO2	Total CO2	CH4	N2O	CO2e
Category	lb/day										lb/day					
Fugitive Dust					0.0000	0.0000	0.0000	0.0000	0.0000	0.0000			0.0000			0.0000
Off-Road	0.8464	8.4073	7.4973	0.0188		0.3303	0.3303		0.3039	0.3039		1,820.3309	1,820.3309	0.5887		1,835.0492
Total	0.8464	8.4073	7.4973	0.0188	0.0000	0.3303	0.3303	0.0000	0.3039	0.3039		1,820.3309	1,820.3309	0.5887		1,835.0492

Vega SES 4 Solar Energy Storage Project - Imperial County, Summer

EMFAC Off-Model Adjustment Factors for Gasoline Light Duty Vehicle to Account for the SAFE Vehicle Rule Not Applied

3.2 Site Preparation - 2023

Unmitigated Construction Off-Site

	ROG	NOx	CO	SO2	Fugitive PM10	Exhaust PM10	PM10 Total	Fugitive PM2.5	Exhaust PM2.5	PM2.5 Total	Bio- CO2	NBio- CO2	Total CO2	CH4	N2O	CO2e
Category	lb/day										lb/day					
Hauling	0.0000	0.0000	0.0000	0.0000	0.0000	0.0000	0.0000	0.0000	0.0000	0.0000		0.0000	0.0000	0.0000	0.0000	0.0000
Vendor	0.0199	0.4045	0.1319	3.0800e-003	119.2980	5.2500e-003	119.3033	11.9190	5.0300e-003	11.9240		324.2947	324.2947	9.3000e-004	0.0443	337.5192
Worker	0.0501	0.0232	0.3497	7.2000e-004	16.5824	3.8000e-004	16.5828	1.6665	3.5000e-004	1.6668		72.8603	72.8603	2.3100e-003	2.1400e-003	73.5570
Total	0.0700	0.4277	0.4816	3.8000e-003	135.8804	5.6300e-003	135.8860	13.5855	5.3800e-003	13.5909		397.1550	397.1550	3.2400e-003	0.0464	411.0761

Mitigated Construction On-Site

	ROG	NOx	CO	SO2	Fugitive PM10	Exhaust PM10	PM10 Total	Fugitive PM2.5	Exhaust PM2.5	PM2.5 Total	Bio- CO2	NBio- CO2	Total CO2	CH4	N2O	CO2e
Category	lb/day										lb/day					
Fugitive Dust					0.0000	0.0000	0.0000	0.0000	0.0000	0.0000			0.0000			0.0000
Off-Road	0.8464	8.4073	7.4973	0.0188		0.3303	0.3303		0.3039	0.3039	0.0000	1,820.3309	1,820.3309	0.5887		1,835.0492
Total	0.8464	8.4073	7.4973	0.0188	0.0000	0.3303	0.3303	0.0000	0.3039	0.3039	0.0000	1,820.3309	1,820.3309	0.5887		1,835.0492

Vega SES 4 Solar Energy Storage Project - Imperial County, Summer

EMFAC Off-Model Adjustment Factors for Gasoline Light Duty Vehicle to Account for the SAFE Vehicle Rule Not Applied

3.2 Site Preparation - 2023

Mitigated Construction Off-Site

	ROG	NOx	CO	SO2	Fugitive PM10	Exhaust PM10	PM10 Total	Fugitive PM2.5	Exhaust PM2.5	PM2.5 Total	Bio- CO2	NBio- CO2	Total CO2	CH4	N2O	CO2e
Category	lb/day										lb/day					
Hauling	0.0000	0.0000	0.0000	0.0000	0.0000	0.0000	0.0000	0.0000	0.0000	0.0000		0.0000	0.0000	0.0000	0.0000	0.0000
Vendor	0.0199	0.4045	0.1319	3.0800e-003	11.0155	5.2500e-003	11.0208	1.1123	5.0300e-003	1.1173		324.2947	324.2947	9.3000e-004	0.0443	337.5192
Worker	0.0501	0.0232	0.3497	7.2000e-004	1.5866	3.8000e-004	1.5870	0.1699	3.5000e-004	0.1702		72.8603	72.8603	2.3100e-003	2.1400e-003	73.5570
Total	0.0700	0.4277	0.4816	3.8000e-003	12.6022	5.6300e-003	12.6078	1.2822	5.3800e-003	1.2876		397.1550	397.1550	3.2400e-003	0.0464	411.0761

3.3 Grading - 2023

Unmitigated Construction On-Site

	ROG	NOx	CO	SO2	Fugitive PM10	Exhaust PM10	PM10 Total	Fugitive PM2.5	Exhaust PM2.5	PM2.5 Total	Bio- CO2	NBio- CO2	Total CO2	CH4	N2O	CO2e
Category	lb/day										lb/day					
Fugitive Dust					16.8164	0.0000	16.8164	7.1358	0.0000	7.1358			0.0000			0.0000
Off-Road	5.4534	57.1174	45.5209	0.1004		2.3502	2.3502		2.1621	2.1621		9,723.5530	9,723.5530	3.1448		9,802.1729
Total	5.4534	57.1174	45.5209	0.1004	16.8164	2.3502	19.1666	7.1358	2.1621	9.2979		9,723.5530	9,723.5530	3.1448		9,802.1729

Vega SES 4 Solar Energy Storage Project - Imperial County, Summer

EMFAC Off-Model Adjustment Factors for Gasoline Light Duty Vehicle to Account for the SAFE Vehicle Rule Not Applied

3.3 Grading - 2023

Unmitigated Construction Off-Site

	ROG	NOx	CO	SO2	Fugitive PM10	Exhaust PM10	PM10 Total	Fugitive PM2.5	Exhaust PM2.5	PM2.5 Total	Bio- CO2	NBio- CO2	Total CO2	CH4	N2O	CO2e
Category	lb/day										lb/day					
Hauling	0.0000	0.0000	0.0000	0.0000	0.0000	0.0000	0.0000	0.0000	0.0000	0.0000		0.0000	0.0000	0.0000	0.0000	0.0000
Vendor	0.0199	0.4045	0.1319	3.0800e-003	119.2980	5.2500e-003	119.3033	11.9190	5.0300e-003	11.9240		324.2947	324.2947	9.3000e-004	0.0443	337.5192
Worker	0.1903	0.0881	1.3288	2.7400e-003	63.0131	1.4600e-003	63.0146	6.3326	1.3500e-003	6.3339		276.8690	276.8690	8.7600e-003	8.1500e-003	279.5164
Total	0.2102	0.4926	1.4607	5.8200e-003	182.3111	6.7100e-003	182.3179	18.2516	6.3800e-003	18.2580		601.1637	601.1637	9.6900e-003	0.0525	617.0356

Mitigated Construction On-Site

	ROG	NOx	CO	SO2	Fugitive PM10	Exhaust PM10	PM10 Total	Fugitive PM2.5	Exhaust PM2.5	PM2.5 Total	Bio- CO2	NBio- CO2	Total CO2	CH4	N2O	CO2e
Category	lb/day										lb/day					
Fugitive Dust					6.5584	0.0000	6.5584	2.7829	0.0000	2.7829			0.0000			0.0000
Off-Road	5.4534	57.1174	45.5209	0.1004		2.3502	2.3502		2.1621	2.1621	0.0000	9,723.5530	9,723.5530	3.1448		9,802.1729
Total	5.4534	57.1174	45.5209	0.1004	6.5584	2.3502	8.9086	2.7829	2.1621	4.9451	0.0000	9,723.5530	9,723.5530	3.1448		9,802.1729

Vega SES 4 Solar Energy Storage Project - Imperial County, Summer

EMFAC Off-Model Adjustment Factors for Gasoline Light Duty Vehicle to Account for the SAFE Vehicle Rule Not Applied

3.3 Grading - 2023

Mitigated Construction Off-Site

	ROG	NOx	CO	SO2	Fugitive PM10	Exhaust PM10	PM10 Total	Fugitive PM2.5	Exhaust PM2.5	PM2.5 Total	Bio- CO2	NBio- CO2	Total CO2	CH4	N2O	CO2e
Category	lb/day										lb/day					
Hauling	0.0000	0.0000	0.0000	0.0000	0.0000	0.0000	0.0000	0.0000	0.0000	0.0000		0.0000	0.0000	0.0000	0.0000	0.0000
Vendor	0.0199	0.4045	0.1319	3.0800e-003	11.0155	5.2500e-003	11.0208	1.1123	5.0300e-003	1.1173		324.2947	324.2947	9.3000e-004	0.0443	337.5192
Worker	0.1903	0.0881	1.3288	2.7400e-003	6.0291	1.4600e-003	6.0306	0.6455	1.3500e-003	0.6469		276.8690	276.8690	8.7600e-003	8.1500e-003	279.5164
Total	0.2102	0.4926	1.4607	5.8200e-003	17.0447	6.7100e-003	17.0514	1.7578	6.3800e-003	1.7642		601.1637	601.1637	9.6900e-003	0.0525	617.0356

3.4 Building Construction - 2023

Unmitigated Construction On-Site

	ROG	NOx	CO	SO2	Fugitive PM10	Exhaust PM10	PM10 Total	Fugitive PM2.5	Exhaust PM2.5	PM2.5 Total	Bio- CO2	NBio- CO2	Total CO2	CH4	N2O	CO2e
Category	lb/day										lb/day					
Off-Road	2.9498	30.0468	36.2147	0.0564		1.4917	1.4917		1.3755	1.3755		5,412.1870	5,412.1870	1.7201		5,455.1901
Total	2.9498	30.0468	36.2147	0.0564		1.4917	1.4917		1.3755	1.3755		5,412.1870	5,412.1870	1.7201		5,455.1901

Vega SES 4 Solar Energy Storage Project - Imperial County, Summer

EMFAC Off-Model Adjustment Factors for Gasoline Light Duty Vehicle to Account for the SAFE Vehicle Rule Not Applied

3.4 Building Construction - 2023

Unmitigated Construction Off-Site

	ROG	NOx	CO	SO2	Fugitive PM10	Exhaust PM10	PM10 Total	Fugitive PM2.5	Exhaust PM2.5	PM2.5 Total	Bio- CO2	NBio- CO2	Total CO2	CH4	N2O	CO2e
Category	lb/day										lb/day					
Hauling	0.0000	0.0000	0.0000	0.0000	0.0000	0.0000	0.0000	0.0000	0.0000	0.0000		0.0000	0.0000	0.0000	0.0000	0.0000
Vendor	0.0199	0.4045	0.1319	3.0800e-003	119.2980	5.2500e-003	119.3033	11.9190	5.0300e-003	11.9240		324.2947	324.2947	9.3000e-004	0.0443	337.5192
Worker	2.5037	1.1587	17.4841	0.0360	829.1202	0.0192	829.1395	83.3236	0.0177	83.3413		3,643.0131	3,643.0131	0.1153	0.1072	3,677.8475
Total	2.5236	1.5632	17.6160	0.0391	948.4182	0.0245	948.4427	95.2426	0.0227	95.2653		3,967.3078	3,967.3078	0.1162	0.1515	4,015.3666

Mitigated Construction On-Site

	ROG	NOx	CO	SO2	Fugitive PM10	Exhaust PM10	PM10 Total	Fugitive PM2.5	Exhaust PM2.5	PM2.5 Total	Bio- CO2	NBio- CO2	Total CO2	CH4	N2O	CO2e
Category	lb/day										lb/day					
Off-Road	2.9498	30.0468	36.2147	0.0564		1.4917	1.4917		1.3755	1.3755	0.0000	5,412.1870	5,412.1870	1.7201		5,455.1901
Total	2.9498	30.0468	36.2147	0.0564		1.4917	1.4917		1.3755	1.3755	0.0000	5,412.1870	5,412.1870	1.7201		5,455.1901

Vega SES 4 Solar Energy Storage Project - Imperial County, Summer

EMFAC Off-Model Adjustment Factors for Gasoline Light Duty Vehicle to Account for the SAFE Vehicle Rule Not Applied

3.4 Building Construction - 2023

Mitigated Construction Off-Site

	ROG	NOx	CO	SO2	Fugitive PM10	Exhaust PM10	PM10 Total	Fugitive PM2.5	Exhaust PM2.5	PM2.5 Total	Bio- CO2	NBio- CO2	Total CO2	CH4	N2O	CO2e
Category	lb/day										lb/day					
Hauling	0.0000	0.0000	0.0000	0.0000	0.0000	0.0000	0.0000	0.0000	0.0000	0.0000		0.0000	0.0000	0.0000	0.0000	0.0000
Vendor	0.0199	0.4045	0.1319	3.0800e-003	11.0155	5.2500e-003	11.0208	1.1123	5.0300e-003	1.1173		324.2947	324.2947	9.3000e-004	0.0443	337.5192
Worker	2.5037	1.1587	17.4841	0.0360	79.3306	0.0192	79.3498	8.4939	0.0177	8.5116		3,643.0131	3,643.0131	0.1153	0.1072	3,677.8475
Total	2.5236	1.5632	17.6160	0.0391	90.3461	0.0245	90.3706	9.6062	0.0227	9.6289		3,967.3078	3,967.3078	0.1162	0.1515	4,015.3666

3.4 Building Construction - 2024

Unmitigated Construction On-Site

	ROG	NOx	CO	SO2	Fugitive PM10	Exhaust PM10	PM10 Total	Fugitive PM2.5	Exhaust PM2.5	PM2.5 Total	Bio- CO2	NBio- CO2	Total CO2	CH4	N2O	CO2e
Category	lb/day										lb/day					
Off-Road	2.8438	28.6031	36.2160	0.0564		1.3862	1.3862		1.2785	1.2785		5,412.5100	5,412.5100	1.7202		5,455.5157
Total	2.8438	28.6031	36.2160	0.0564		1.3862	1.3862		1.2785	1.2785		5,412.5100	5,412.5100	1.7202		5,455.5157

Vega SES 4 Solar Energy Storage Project - Imperial County, Summer

EMFAC Off-Model Adjustment Factors for Gasoline Light Duty Vehicle to Account for the SAFE Vehicle Rule Not Applied

3.4 Building Construction - 2024

Unmitigated Construction Off-Site

	ROG	NOx	CO	SO2	Fugitive PM10	Exhaust PM10	PM10 Total	Fugitive PM2.5	Exhaust PM2.5	PM2.5 Total	Bio- CO2	NBio- CO2	Total CO2	CH4	N2O	CO2e
Category	lb/day										lb/day					
Hauling	0.0000	0.0000	0.0000	0.0000	0.0000	0.0000	0.0000	0.0000	0.0000	0.0000		0.0000	0.0000	0.0000	0.0000	0.0000
Vendor	0.0189	0.4030	0.1231	3.0400e-003	119.2980	5.2400e-003	119.3032	11.9190	5.0100e-003	11.9240		319.8973	319.8973	8.8000e-004	0.0435	332.8703
Worker	2.3203	1.0290	16.1232	0.0350	829.1202	0.0182	829.1384	83.3236	0.0168	83.3404		3,533.3239	3,533.3239	0.1039	0.0991	3,565.4648
Total	2.3392	1.4319	16.2463	0.0380	948.4182	0.0235	948.4417	95.2426	0.0218	95.2644		3,853.2212	3,853.2212	0.1048	0.1426	3,898.3351

Mitigated Construction On-Site

	ROG	NOx	CO	SO2	Fugitive PM10	Exhaust PM10	PM10 Total	Fugitive PM2.5	Exhaust PM2.5	PM2.5 Total	Bio- CO2	NBio- CO2	Total CO2	CH4	N2O	CO2e
Category	lb/day										lb/day					
Off-Road	2.8438	28.6031	36.2160	0.0564		1.3862	1.3862		1.2785	1.2785	0.0000	5,412.5100	5,412.5100	1.7202		5,455.5157
Total	2.8438	28.6031	36.2160	0.0564		1.3862	1.3862		1.2785	1.2785	0.0000	5,412.5100	5,412.5100	1.7202		5,455.5157

Vega SES 4 Solar Energy Storage Project - Imperial County, Summer

EMFAC Off-Model Adjustment Factors for Gasoline Light Duty Vehicle to Account for the SAFE Vehicle Rule Not Applied

3.4 Building Construction - 2024

Mitigated Construction Off-Site

	ROG	NOx	CO	SO2	Fugitive PM10	Exhaust PM10	PM10 Total	Fugitive PM2.5	Exhaust PM2.5	PM2.5 Total	Bio- CO2	NBio- CO2	Total CO2	CH4	N2O	CO2e
Category	lb/day										lb/day					
Hauling	0.0000	0.0000	0.0000	0.0000	0.0000	0.0000	0.0000	0.0000	0.0000	0.0000		0.0000	0.0000	0.0000	0.0000	0.0000
Vendor	0.0189	0.4030	0.1231	3.0400e-003	11.0155	5.2400e-003	11.0208	1.1123	5.0100e-003	1.1173		319.8973	319.8973	8.8000e-004	0.0435	332.8703
Worker	2.3203	1.0290	16.1232	0.0350	79.3306	0.0182	79.3488	8.4939	0.0168	8.5107		3,533.3239	3,533.3239	0.1039	0.0991	3,565.4648
Total	2.3392	1.4319	16.2463	0.0380	90.3461	0.0235	90.3696	9.6062	0.0218	9.6280		3,853.2212	3,853.2212	0.1048	0.1426	3,898.3351

4.0 Operational Detail - Mobile

4.1 Mitigation Measures Mobile

Vega SES 4 Solar Energy Storage Project - Imperial County, Summer

EMFAC Off-Model Adjustment Factors for Gasoline Light Duty Vehicle to Account for the SAFE Vehicle Rule Not Applied

	ROG	NOx	CO	SO2	Fugitive PM10	Exhaust PM10	PM10 Total	Fugitive PM2.5	Exhaust PM2.5	PM2.5 Total	Bio- CO2	NBio- CO2	Total CO2	CH4	N2O	CO2e
Category	lb/day										lb/day					
Mitigated	0.0294	0.0355	0.3113	6.4000e-004	4.8460	4.4000e-004	4.8464	0.4922	4.1000e-004	0.4927		64.8492	64.8492	2.6500e-003	2.7400e-003	65.7319
Unmitigated	0.0294	0.0355	0.3113	6.4000e-004	4.8460	4.4000e-004	4.8464	0.4922	4.1000e-004	0.4927		64.8492	64.8492	2.6500e-003	2.7400e-003	65.7319

4.2 Trip Summary Information

Land Use	Average Daily Trip Rate			Unmitigated	Mitigated
	Weekday	Saturday	Sunday	Annual VMT	Annual VMT
Refrigerated Warehouse-No Rail	2.96	0.00	0.00	10,455	10,455
Refrigerated Warehouse-No Rail	2.96	0.00	0.00	10,455	10,455
Other Non-Asphalt Surfaces	0.00	0.00	0.00		
Other Non-Asphalt Surfaces	0.00	0.00	0.00		
Total	5.92	0.00	0.00	20,910	20,910

4.3 Trip Type Information

Land Use	Miles			Trip %			Trip Purpose %		
	H-W or C-W	H-S or C-C	H-O or C-NW	H-W or C-W	H-S or C-C	H-O or C-NW	Primary	Diverted	Pass-by
Refrigerated Warehouse-No	16.40	9.50	11.90	59.00	0.00	41.00	92	5	3
Refrigerated Warehouse-No	16.40	9.50	11.90	59.00	0.00	41.00	92	5	3
Other Non-Asphalt Surfaces	16.40	9.50	11.90	0.00	0.00	0.00	0	0	0
Other Non-Asphalt Surfaces	16.40	9.50	11.90	0.00	0.00	0.00	0	0	0

4.4 Fleet Mix

Vega SES 4 Solar Energy Storage Project - Imperial County, Summer

EMFAC Off-Model Adjustment Factors for Gasoline Light Duty Vehicle to Account for the SAFE Vehicle Rule Not Applied

Land Use	LDA	LDT1	LDT2	MDV	LHD1	LHD2	MHD	HHD	OBUS	UBUS	MCY	SBUS	MH
Refrigerated Warehouse-No Rail	0.521846	0.059402	0.180067	0.151114	0.027614	0.006908	0.008276	0.016396	0.000918	0.000121	0.022925	0.000779	0.003633
Other Non-Asphalt Surfaces	0.521846	0.059402	0.180067	0.151114	0.027614	0.006908	0.008276	0.016396	0.000918	0.000121	0.022925	0.000779	0.003633

5.0 Energy Detail

Historical Energy Use: N

5.1 Mitigation Measures Energy

Percent of Electricity Use Generated with Renewable Energy

Category	ROG	NOx	CO	SO2	Fugitive PM10	Exhaust PM10	PM10 Total	Fugitive PM2.5	Exhaust PM2.5	PM2.5 Total	Bio- CO2	NBio- CO2	Total CO2	CH4	N2O	CO2e
Category	lb/day										lb/day					
NaturalGas Mitigated	0.2663	2.4210	2.0337	0.0145		0.1840	0.1840		0.1840	0.1840		2,905.2168	2,905.2168	0.0557	0.0533	2,922.4811
NaturalGas Unmitigated	0.2663	2.4210	2.0337	0.0145		0.1840	0.1840		0.1840	0.1840		2,905.2168	2,905.2168	0.0557	0.0533	2,922.4811

Vega SES 4 Solar Energy Storage Project - Imperial County, Summer

EMFAC Off-Model Adjustment Factors for Gasoline Light Duty Vehicle to Account for the SAFE Vehicle Rule Not Applied

5.2 Energy by Land Use - NaturalGas

Unmitigated

	NaturalGas Use	ROG	NOx	CO	SO2	Fugitive PM10	Exhaust PM10	PM10 Total	Fugitive PM2.5	Exhaust PM2.5	PM2.5 Total	Bio- CO2	NBio- CO2	Total CO2	CH4	N2O	CO2e
Land Use	kBTU/yr	lb/day										lb/day					
Other Non-Asphalt Surfaces	0	0.0000	0.0000	0.0000	0.0000		0.0000	0.0000		0.0000	0.0000		0.0000	0.0000	0.0000	0.0000	0.0000
Refrigerated Warehouse-No Rail	12347.2	0.2663	2.4210	2.0337	0.0145		0.1840	0.1840		0.1840	0.1840		2,905.2168	2,905.2168	0.0557	0.0533	2,922.4811
Total		0.2663	2.4210	2.0337	0.0145		0.1840	0.1840		0.1840	0.1840		2,905.2168	2,905.2168	0.0557	0.0533	2,922.4811

Mitigated

	NaturalGas Use	ROG	NOx	CO	SO2	Fugitive PM10	Exhaust PM10	PM10 Total	Fugitive PM2.5	Exhaust PM2.5	PM2.5 Total	Bio- CO2	NBio- CO2	Total CO2	CH4	N2O	CO2e
Land Use	kBTU/yr	lb/day										lb/day					
Other Non-Asphalt Surfaces	0	0.0000	0.0000	0.0000	0.0000		0.0000	0.0000		0.0000	0.0000		0.0000	0.0000	0.0000	0.0000	0.0000
Refrigerated Warehouse-No Rail	12.3472	0.2663	2.4210	2.0337	0.0145		0.1840	0.1840		0.1840	0.1840		2,905.2168	2,905.2168	0.0557	0.0533	2,922.4811
Total		0.2663	2.4210	2.0337	0.0145		0.1840	0.1840		0.1840	0.1840		2,905.2168	2,905.2168	0.0557	0.0533	2,922.4811

6.0 Area Detail

Vega SES 4 Solar Energy Storage Project - Imperial County, Summer

EMFAC Off-Model Adjustment Factors for Gasoline Light Duty Vehicle to Account for the SAFE Vehicle Rule Not Applied

6.1 Mitigation Measures Area

	ROG	NOx	CO	SO2	Fugitive PM10	Exhaust PM10	PM10 Total	Fugitive PM2.5	Exhaust PM2.5	PM2.5 Total	Bio- CO2	NBio- CO2	Total CO2	CH4	N2O	CO2e
Category	lb/day										lb/day					
Mitigated	13.5919	5.8000e-004	0.0638	0.0000		2.3000e-004	2.3000e-004		2.3000e-004	2.3000e-004		0.1367	0.1367	3.6000e-004		0.1457
Unmitigated	13.5919	5.8000e-004	0.0638	0.0000		2.3000e-004	2.3000e-004		2.3000e-004	2.3000e-004		0.1367	0.1367	3.6000e-004		0.1457

6.2 Area by SubCategory

Unmitigated

	ROG	NOx	CO	SO2	Fugitive PM10	Exhaust PM10	PM10 Total	Fugitive PM2.5	Exhaust PM2.5	PM2.5 Total	Bio- CO2	NBio- CO2	Total CO2	CH4	N2O	CO2e
SubCategory	lb/day										lb/day					
Architectural Coating	2.9065					0.0000	0.0000		0.0000	0.0000			0.0000			0.0000
Consumer Products	10.6795					0.0000	0.0000		0.0000	0.0000			0.0000			0.0000
Landscaping	5.9100e-003	5.8000e-004	0.0638	0.0000		2.3000e-004	2.3000e-004		2.3000e-004	2.3000e-004		0.1367	0.1367	3.6000e-004		0.1457
Total	13.5919	5.8000e-004	0.0638	0.0000		2.3000e-004	2.3000e-004		2.3000e-004	2.3000e-004		0.1367	0.1367	3.6000e-004		0.1457

Vega SES 4 Solar Energy Storage Project - Imperial County, Summer

EMFAC Off-Model Adjustment Factors for Gasoline Light Duty Vehicle to Account for the SAFE Vehicle Rule Not Applied

6.2 Area by SubCategory

Mitigated

	ROG	NOx	CO	SO2	Fugitive PM10	Exhaust PM10	PM10 Total	Fugitive PM2.5	Exhaust PM2.5	PM2.5 Total	Bio- CO2	NBio- CO2	Total CO2	CH4	N2O	CO2e
SubCategory	lb/day										lb/day					
Architectural Coating	2.9065					0.0000	0.0000		0.0000	0.0000			0.0000			0.0000
Consumer Products	10.6795					0.0000	0.0000		0.0000	0.0000			0.0000			0.0000
Landscaping	5.9100e-003	5.8000e-004	0.0638	0.0000		2.3000e-004	2.3000e-004		2.3000e-004	2.3000e-004		0.1367	0.1367	3.6000e-004		0.1457
Total	13.5919	5.8000e-004	0.0638	0.0000		2.3000e-004	2.3000e-004		2.3000e-004	2.3000e-004		0.1367	0.1367	3.6000e-004		0.1457

7.0 Water Detail

7.1 Mitigation Measures Water

8.0 Waste Detail

8.1 Mitigation Measures Waste

9.0 Operational Offroad

Equipment Type	Number	Hours/Day	Days/Year	Horse Power	Load Factor	Fuel Type
Other Construction Equipment	3	8.00	8	172	0.42	Diesel
Off-Highway Trucks	1	2.00	8	402	0.38	Diesel

Vega SES 4 Solar Energy Storage Project - Imperial County, Summer

EMFAC Off-Model Adjustment Factors for Gasoline Light Duty Vehicle to Account for the SAFE Vehicle Rule Not Applied

UnMitigated/Mitigated

	ROG	NOx	CO	SO2	Fugitive PM10	Exhaust PM10	PM10 Total	Fugitive PM2.5	Exhaust PM2.5	PM2.5 Total	Bio- CO2	NBio- CO2	Total CO2	CH4	N2O	CO2e
Equipment Type	lb/day										lb/day					
Off-Highway Trucks	0.1266	0.8964	0.8262	3.3200e-003		0.0324	0.0324		0.0298	0.0298	0.0000	321.5720	321.5720	0.1040		324.1721
Other Construction Equipment	1.0338	10.2004	11.8763	0.0183		0.5310	0.5310		0.4885	0.4885	0.0000	1,775.1278	1,775.1278	0.5741		1,789.4806
Total	1.1604	11.0968	12.7025	0.0217		0.5634	0.5634		0.5184	0.5184	0.0000	2,096.6998	2,096.6998	0.6781		2,113.6527

10.0 Stationary Equipment

Fire Pumps and Emergency Generators

Equipment Type	Number	Hours/Day	Hours/Year	Horse Power	Load Factor	Fuel Type
----------------	--------	-----------	------------	-------------	-------------	-----------

Boilers

Equipment Type	Number	Heat Input/Day	Heat Input/Year	Boiler Rating	Fuel Type
----------------	--------	----------------	-----------------	---------------	-----------

User Defined Equipment

Equipment Type	Number
----------------	--------

11.0 Vegetation

Vega SES 4 Solar Energy Storage Project - Imperial County, Winter

EMFAC Off-Model Adjustment Factors for Gasoline Light Duty Vehicle to Account for the SAFE Vehicle Rule Not Applied

**Vega SES 4 Solar Energy Storage Project
Imperial County, Winter**

1.0 Project Characteristics

1.1 Land Usage

Land Uses	Size	Metric	Lot Acreage	Floor Surface Area	Population
Other Non-Asphalt Surfaces	447.00	Acre	447.00	19,471,320.00	0
Refrigerated Warehouse-No Rail	87.12	1000sqft	2.00	87,120.00	0
Refrigerated Warehouse-No Rail	87.12	1000sqft	2.00	87,120.00	0
Other Non-Asphalt Surfaces	3.50	Acre	3.50	152,460.00	0

1.2 Other Project Characteristics

Urbanization	Rural	Wind Speed (m/s)	3.4	Precipitation Freq (Days)	12
Climate Zone	15			Operational Year	2023
Utility Company	Imperial Irrigation District				
CO2 Intensity (lb/MWhr)	189.98	CH4 Intensity (lb/MWhr)	0.033	N2O Intensity (lb/MWhr)	0.004

1.3 User Entered Comments & Non-Default Data

Project Characteristics -

Land Use - Land Uses account for 447 acres of solar field, 2 acres of BESS, 2 acres of Substation, and 3.5 acres of Staging/Parking Area

Construction Phase - Construction timing per Project Applicant

Off-road Equipment - Construction equipment per Project applicant. Plate compactor = pile driver.

Off-road Equipment - Ibid

Off-road Equipment - Construction equipment per Project applicant.

Trips and VMT - Maximun 500 worker commute trips per Traffic Study. 20.25 miles added to vendor route for extended access along border.

On-road Fugitive Dust - 89% paved roads for worker commutes [1.15 m dirt roads / 10.2 m trip length default = 89% paved roads]. Traffic Study identifies worker commute routes north of Staging/Parking Area as 100% paved. 37% paved for vendor/equipment hauling trips. Trips require additional 20.25 miles of distance on dirt roadway.

PC ORIGINAL PKG

Vega SES 4 Solar Energy Storage Project - Imperial County, Winter

EMFAC Off-Model Adjustment Factors for Gasoline Light Duty Vehicle to Account for the SAFE Vehicle Rule Not Applied

Grading -

Vehicle Trips - Maximum daily trips = 6 per Traffic Study

Road Dust - 92% paved roads for operational worker commutes [1.15 m dirt roads / 14.55 m trip length default weighted average = 92% paved roads].

Energy Use - Solar facility- no operational energy use.

Water And Wastewater - Water use being kept for light industrial land use as the solar panels may need to be cleaned.

Solid Waste - No solid waste- solar facility.

Construction Off-road Equipment Mitigation - Mitigation measure AQ-1 accounted. PM Reduction value for applying soil stabilizers to unpaved roadways per communication with ICAPCD (Monica Soucier via email correspondence).

Mobile Land Use Mitigation -

Energy Mitigation -

Operational Off-Road Equipment - Onsite maintenance expected 4 times annually.

Table Name	Column Name	Default Value	New Value
tblConstDustMitigation	WaterUnpavedRoadVehicleSpeed	40	15
tblConstructionPhase	NumDays	7,750.00	286.00
tblConstructionPhase	NumDays	775.00	66.00
tblConstructionPhase	NumDays	300.00	33.00
tblConstructionPhase	PhaseEndDate	9/30/2055	7/25/2024
tblConstructionPhase	PhaseEndDate	1/15/2026	6/21/2023
tblConstructionPhase	PhaseEndDate	1/26/2023	3/21/2023
tblConstructionPhase	PhaseStartDate	1/16/2026	6/22/2023
tblConstructionPhase	PhaseStartDate	1/27/2023	3/22/2023
tblConstructionPhase	PhaseStartDate	12/3/2021	2/3/2023
tblOffRoadEquipment	LoadFactor	0.36	0.36
tblOffRoadEquipment	LoadFactor	0.40	0.40
tblOffRoadEquipment	LoadFactor	0.42	0.42
tblOffRoadEquipment	LoadFactor	0.36	0.36
tblOffRoadEquipment	LoadFactor	0.50	0.50
tblOffRoadEquipment	LoadFactor	0.38	0.38
tblOffRoadEquipment	OffRoadEquipmentType	PC ORIGINAL PKG	Rubber Tired Loaders

Vega SES 4 Solar Energy Storage Project - Imperial County, Winter

EMFAC Off-Model Adjustment Factors for Gasoline Light Duty Vehicle to Account for the SAFE Vehicle Rule Not Applied

tblOffRoadEquipment	OffRoadEquipmentType		Rough Terrain Forklifts
tblOffRoadEquipment	OffRoadEquipmentType		Pavers
tblOffRoadEquipment	OffRoadEquipmentType		Paving Equipment
tblOffRoadEquipment	OffRoadEquipmentType		Plate Compactors
tblOffRoadEquipment	OffRoadEquipmentType		Trenchers
tblOffRoadEquipment	OffRoadEquipmentType		Rollers
tblOffRoadEquipment	OffRoadEquipmentUnitAmount	2.00	4.00
tblOffRoadEquipment	OffRoadEquipmentUnitAmount	3.00	0.00
tblOffRoadEquipment	OffRoadEquipmentUnitAmount	1.00	0.00
tblOffRoadEquipment	OffRoadEquipmentUnitAmount	1.00	3.00
tblOffRoadEquipment	OffRoadEquipmentUnitAmount	1.00	2.00
tblOffRoadEquipment	OffRoadEquipmentUnitAmount	3.00	0.00
tblOffRoadEquipment	OffRoadEquipmentUnitAmount	3.00	4.00
tblOffRoadEquipment	OffRoadEquipmentUnitAmount	2.00	4.00
tblOffRoadEquipment	OffRoadEquipmentUnitAmount	4.00	2.00
tblOffRoadEquipment	OffRoadEquipmentUnitAmount	1.00	0.00
tblOnRoadDust	VendorPercentPave	50.00	37.00
tblOnRoadDust	VendorPercentPave	50.00	37.00
tblOnRoadDust	VendorPercentPave	50.00	37.00
tblOnRoadDust	WorkerPercentPave	50.00	89.00
tblOnRoadDust	WorkerPercentPave	50.00	89.00
tblOnRoadDust	WorkerPercentPave	50.00	89.00
tblOperationalOffRoadEquipment	OperDaysPerYear	260.00	8.00
tblOperationalOffRoadEquipment	OperDaysPerYear	260.00	8.00
tblOperationalOffRoadEquipment	OperHoursPerDay	8.00	2.00
tblOperationalOffRoadEquipment	OperLoadFactor	0.42	0.42
tblOperationalOffRoadEquipment	OperLoadFactor	0.38	0.38
tblOperationalOffRoadEquipment	OperOffRoadEquipmentNumber	0.00	3.00
tblOperationalOffRoadEquipment	OperOffRoadEquipmentNumber	0.00	1.00

PC ORIGINAL PKG

Vega SES 4 Solar Energy Storage Project - Imperial County, Winter

EMFAC Off-Model Adjustment Factors for Gasoline Light Duty Vehicle to Account for the SAFE Vehicle Rule Not Applied

tblProjectCharacteristics	UrbanizationLevel	Urban	Rural
tblRoadDust	RoadPercentPave	50	92
tblTripsAndVMT	VendorTripLength	11.90	32.15
tblTripsAndVMT	VendorTripLength	11.90	32.15
tblTripsAndVMT	VendorTripLength	11.90	32.15
tblTripsAndVMT	VendorTripNumber	0.00	4.00
tblTripsAndVMT	VendorTripNumber	0.00	4.00
tblTripsAndVMT	VendorTripNumber	3,245.00	4.00
tblTripsAndVMT	WorkerTripNumber	8,315.00	500.00
tblVehicleTrips	ST_TR	2.12	0.00
tblVehicleTrips	SU_TR	2.12	0.00
tblVehicleTrips	WD_TR	2.12	0.03
tblWater	IndoorWaterUseRate	40,293,000.00	3,259,000.00

2.0 Emissions Summary

Vega SES 4 Solar Energy Storage Project - Imperial County, Winter

EMFAC Off-Model Adjustment Factors for Gasoline Light Duty Vehicle to Account for the SAFE Vehicle Rule Not Applied

2.1 Overall Construction (Maximum Daily Emission)

Unmitigated Construction

	ROG	NOx	CO	SO2	Fugitive PM10	Exhaust PM10	PM10 Total	Fugitive PM2.5	Exhaust PM2.5	PM2.5 Total	Bio- CO2	NBio- CO2	Total CO2	CH4	N2O	CO2e
Year	lb/day										lb/day					
2023	5.6158	57.6586	48.8527	0.1058	948.4182	2.3569	949.9344	95.2426	2.1685	96.6408	0.0000	10,283.40 13	10,283.40 13	3.1545	0.1542	10,377.99 89
2024	4.6139	30.1241	47.8943	0.0892	948.4182	1.4097	949.8279	95.2426	1.3002	96.5428	0.0000	8,737.131 7	8,737.131 7	1.8264	0.1449	8,825.984 3
Maximum	5.6158	57.6586	48.8527	0.1058	948.4182	2.3569	949.9344	95.2426	2.1685	96.6408	0.0000	10,283.40 13	10,283.40 13	3.1545	0.1542	10,377.99 89

Mitigated Construction

	ROG	NOx	CO	SO2	Fugitive PM10	Exhaust PM10	PM10 Total	Fugitive PM2.5	Exhaust PM2.5	PM2.5 Total	Bio- CO2	NBio- CO2	Total CO2	CH4	N2O	CO2e
Year	lb/day										lb/day					
2023	5.6158	57.6586	48.8527	0.1058	90.3461	2.3569	91.8623	9.6062	2.1685	11.0044	0.0000	10,283.40 13	10,283.40 13	3.1545	0.1542	10,377.99 89
2024	4.6139	30.1241	47.8943	0.0892	90.3461	1.4097	91.7558	9.6062	1.3002	10.9064	0.0000	8,737.131 7	8,737.131 7	1.8264	0.1449	8,825.984 3
Maximum	5.6158	57.6586	48.8527	0.1058	90.3461	2.3569	91.8623	9.6062	2.1685	11.0044	0.0000	10,283.40 13	10,283.40 13	3.1545	0.1542	10,377.99 89

Vega SES 4 Solar Energy Storage Project - Imperial County, Winter

EMFAC Off-Model Adjustment Factors for Gasoline Light Duty Vehicle to Account for the SAFE Vehicle Rule Not Applied

	ROG	NOx	CO	SO2	Fugitive PM10	Exhaust PM10	PM10 Total	Fugitive PM2.5	Exhaust PM2.5	PM2.5 Total	Bio- CO2	NBio-CO2	Total CO2	CH4	N2O	CO2e
Percent Reduction	0.00	0.00	0.00	0.00	90.47	0.00	90.33	89.91	0.00	88.66	0.00	0.00	0.00	0.00	0.00	0.00

2.2 Overall Operational

Unmitigated Operational

	ROG	NOx	CO	SO2	Fugitive PM10	Exhaust PM10	PM10 Total	Fugitive PM2.5	Exhaust PM2.5	PM2.5 Total	Bio- CO2	NBio- CO2	Total CO2	CH4	N2O	CO2e
Category	lb/day										lb/day					
Area	13.5919	5.8000e-004	0.0638	0.0000		2.3000e-004	2.3000e-004		2.3000e-004	2.3000e-004		0.1367	0.1367	3.6000e-004		0.1457
Energy	0.2663	2.4210	2.0337	0.0145		0.1840	0.1840		0.1840	0.1840		2,905.2168	2,905.2168	0.0557	0.0533	2,922.4811
Mobile	0.0206	0.0393	0.2405	5.6000e-004	4.8460	4.4000e-004	4.8464	0.4922	4.1000e-004	0.4927		57.0593	57.0593	2.6600e-003	2.8300e-003	57.9690
Offroad	1.1604	11.0968	12.7025	0.0217		0.5634	0.5634		0.5184	0.5184	0.0000	2,096.6998	2,096.6998	0.6781		2,113.6527
Total	15.0393	13.5577	15.0404	0.0367	4.8460	0.7481	5.5941	0.4922	0.7030	1.1952	0.0000	5,059.1127	5,059.1127	0.7368	0.0561	5,094.2485

Vega SES 4 Solar Energy Storage Project - Imperial County, Winter

EMFAC Off-Model Adjustment Factors for Gasoline Light Duty Vehicle to Account for the SAFE Vehicle Rule Not Applied

2.2 Overall Operational

Mitigated Operational

	ROG	NOx	CO	SO2	Fugitive PM10	Exhaust PM10	PM10 Total	Fugitive PM2.5	Exhaust PM2.5	PM2.5 Total	Bio- CO2	NBio- CO2	Total CO2	CH4	N2O	CO2e
Category	lb/day										lb/day					
Area	13.5919	5.8000e-004	0.0638	0.0000		2.3000e-004	2.3000e-004		2.3000e-004	2.3000e-004		0.1367	0.1367	3.6000e-004		0.1457
Energy	0.2663	2.4210	2.0337	0.0145		0.1840	0.1840		0.1840	0.1840		2,905.2168	2,905.2168	0.0557	0.0533	2,922.4811
Mobile	0.0206	0.0393	0.2405	5.6000e-004	4.8460	4.4000e-004	4.8464	0.4922	4.1000e-004	0.4927		57.0593	57.0593	2.6600e-003	2.8300e-003	57.9690
Offroad	1.1604	11.0968	12.7025	0.0217		0.5634	0.5634		0.5184	0.5184	0.0000	2,096.6998	2,096.6998	0.6781		2,113.6527
Total	15.0393	13.5577	15.0404	0.0367	4.8460	0.7481	5.5941	0.4922	0.7030	1.1952	0.0000	5,059.1127	5,059.1127	0.7368	0.0561	5,094.2485

	ROG	NOx	CO	SO2	Fugitive PM10	Exhaust PM10	PM10 Total	Fugitive PM2.5	Exhaust PM2.5	PM2.5 Total	Bio- CO2	NBio- CO2	Total CO2	CH4	N2O	CO2e
Percent Reduction	0.00	0.00	0.00	0.00	0.00	0.00	0.00	0.00	0.00	0.00	0.00	0.00	0.00	0.00	0.00	0.00

3.0 Construction Detail

Construction Phase

Phase Number	Phase Name	Phase Type	Start Date	End Date	Num Days Week	Num Days	Phase Description
1	Site Preparation	Site Preparation	2/3/2023	3/21/2023	5	33	
2	Grading	Grading	3/22/2023	6/21/2023	5	66	
3	Building Construction	Building Construction	6/22/2023	7/25/2024	5	286	

Acres of Grading (Site Preparation Phase): 0

PC ORIGINAL PKG

Vega SES 4 Solar Energy Storage Project - Imperial County, Winter

EMFAC Off-Model Adjustment Factors for Gasoline Light Duty Vehicle to Account for the SAFE Vehicle Rule Not Applied

Acres of Grading (Grading Phase): 297

Acres of Paving: 450.5

Residential Indoor: 0; Residential Outdoor: 0; Non-Residential Indoor: 0; Non-Residential Outdoor: 0; Striped Parking Area: 0 (Architectural Coating – sqft)

OffRoad Equipment

Phase Name	Offroad Equipment Type	Amount	Usage Hours	Horse Power	Load Factor
Site Preparation	Rubber Tired Dozers	0	8.00	247	0.40
Site Preparation	Tractors/Loaders/Backhoes	2	8.00	97	0.37
Grading	Excavators	4	8.00	158	0.38
Grading	Graders	3	8.00	187	0.41
Grading	Rubber Tired Dozers	2	8.00	247	0.40
Grading	Scrapers	2	8.00	367	0.48
Grading	Tractors/Loaders/Backhoes	4	8.00	97	0.37
Building Construction	Cranes	1	7.00	231	0.29
Building Construction	Forklifts	0	8.00	89	0.20
Building Construction	Generator Sets	0	8.00	84	0.74
Site Preparation	Rubber Tired Loaders	2	8.00	203	0.36
Building Construction	Rough Terrain Forklifts	4	8.00	100	0.40
Building Construction	Pavers	1	8.00	130	0.42
Building Construction	Tractors/Loaders/Backhoes	4	7.00	97	0.37
Building Construction	Paving Equipment	2	8.00	132	0.36
Building Construction	Welders	0	8.00	46	0.45
Building Construction	Plate Compactors	4	8.00	8	0.43
Building Construction	Trenchers	2	8.00	78	0.50
Building Construction	Rollers	2	8.00	80	0.38

Trips and VMT

PC ORIGINAL PKG

Vega SES 4 Solar Energy Storage Project - Imperial County, Winter

EMFAC Off-Model Adjustment Factors for Gasoline Light Duty Vehicle to Account for the SAFE Vehicle Rule Not Applied

Phase Name	Offroad Equipment Count	Worker Trip Number	Vendor Trip Number	Hauling Trip Number	Worker Trip Length	Vendor Trip Length	Hauling Trip Length	Worker Vehicle Class	Vendor Vehicle Class	Hauling Vehicle Class
Site Preparation	4	10.00	4.00	0.00	10.20	32.15	20.00	LD_Mix	HDT_Mix	HHDT
Grading	15	38.00	4.00	0.00	10.20	32.15	20.00	LD_Mix	HDT_Mix	HHDT
Building Construction	20	500.00	4.00	0.00	10.20	32.15	20.00	LD_Mix	HDT_Mix	HHDT

3.1 Mitigation Measures Construction

- Use Soil Stabilizer
- Water Exposed Area
- Water Unpaved Roads
- Reduce Vehicle Speed on Unpaved Roads

3.2 Site Preparation - 2023

Unmitigated Construction On-Site

	ROG	NOx	CO	SO2	Fugitive PM10	Exhaust PM10	PM10 Total	Fugitive PM2.5	Exhaust PM2.5	PM2.5 Total	Bio- CO2	NBio- CO2	Total CO2	CH4	N2O	CO2e
Category	lb/day										lb/day					
Fugitive Dust					0.0000	0.0000	0.0000	0.0000	0.0000	0.0000			0.0000			0.0000
Off-Road	0.8464	8.4073	7.4973	0.0188		0.3303	0.3303		0.3039	0.3039		1,820.3309	1,820.3309	0.5887		1,835.0492
Total	0.8464	8.4073	7.4973	0.0188	0.0000	0.3303	0.3303	0.0000	0.3039	0.3039		1,820.3309	1,820.3309	0.5887		1,835.0492

Vega SES 4 Solar Energy Storage Project - Imperial County, Winter

EMFAC Off-Model Adjustment Factors for Gasoline Light Duty Vehicle to Account for the SAFE Vehicle Rule Not Applied

3.2 Site Preparation - 2023

Unmitigated Construction Off-Site

	ROG	NOx	CO	SO2	Fugitive PM10	Exhaust PM10	PM10 Total	Fugitive PM2.5	Exhaust PM2.5	PM2.5 Total	Bio- CO2	NBio- CO2	Total CO2	CH4	N2O	CO2e
Category	lb/day										lb/day					
Hauling	0.0000	0.0000	0.0000	0.0000	0.0000	0.0000	0.0000	0.0000	0.0000	0.0000		0.0000	0.0000	0.0000	0.0000	0.0000
Vendor	0.0195	0.4491	0.1329	3.0900e-003	119.2980	5.2600e-003	119.3033	11.9190	5.0300e-003	11.9240		324.5098	324.5098	9.0000e-004	0.0445	337.7815
Worker	0.0376	0.0242	0.2501	6.1000e-004	16.5824	3.8000e-004	16.5828	1.6665	3.5000e-004	1.6668		61.9312	61.9312	2.3300e-003	2.1900e-003	62.6433
Total	0.0571	0.4733	0.3830	3.7000e-003	135.8804	5.6400e-003	135.8861	13.5855	5.3800e-003	13.5909		386.4410	386.4410	3.2300e-003	0.0467	400.4248

Mitigated Construction On-Site

	ROG	NOx	CO	SO2	Fugitive PM10	Exhaust PM10	PM10 Total	Fugitive PM2.5	Exhaust PM2.5	PM2.5 Total	Bio- CO2	NBio- CO2	Total CO2	CH4	N2O	CO2e
Category	lb/day										lb/day					
Fugitive Dust					0.0000	0.0000	0.0000	0.0000	0.0000	0.0000			0.0000			0.0000
Off-Road	0.8464	8.4073	7.4973	0.0188		0.3303	0.3303		0.3039	0.3039	0.0000	1,820.3309	1,820.3309	0.5887		1,835.0492
Total	0.8464	8.4073	7.4973	0.0188	0.0000	0.3303	0.3303	0.0000	0.3039	0.3039	0.0000	1,820.3309	1,820.3309	0.5887		1,835.0492

Vega SES 4 Solar Energy Storage Project - Imperial County, Winter

EMFAC Off-Model Adjustment Factors for Gasoline Light Duty Vehicle to Account for the SAFE Vehicle Rule Not Applied

3.2 Site Preparation - 2023

Mitigated Construction Off-Site

	ROG	NOx	CO	SO2	Fugitive PM10	Exhaust PM10	PM10 Total	Fugitive PM2.5	Exhaust PM2.5	PM2.5 Total	Bio- CO2	NBio- CO2	Total CO2	CH4	N2O	CO2e
Category	lb/day										lb/day					
Hauling	0.0000	0.0000	0.0000	0.0000	0.0000	0.0000	0.0000	0.0000	0.0000	0.0000		0.0000	0.0000	0.0000	0.0000	0.0000
Vendor	0.0195	0.4491	0.1329	3.0900e-003	11.0155	5.2600e-003	11.0208	1.1123	5.0300e-003	1.1173		324.5098	324.5098	9.0000e-004	0.0445	337.7815
Worker	0.0376	0.0242	0.2501	6.1000e-004	1.5866	3.8000e-004	1.5870	0.1699	3.5000e-004	0.1702		61.9312	61.9312	2.3300e-003	2.1900e-003	62.6433
Total	0.0571	0.4733	0.3830	3.7000e-003	12.6022	5.6400e-003	12.6078	1.2822	5.3800e-003	1.2876		386.4410	386.4410	3.2300e-003	0.0467	400.4248

3.3 Grading - 2023

Unmitigated Construction On-Site

	ROG	NOx	CO	SO2	Fugitive PM10	Exhaust PM10	PM10 Total	Fugitive PM2.5	Exhaust PM2.5	PM2.5 Total	Bio- CO2	NBio- CO2	Total CO2	CH4	N2O	CO2e
Category	lb/day										lb/day					
Fugitive Dust					16.8164	0.0000	16.8164	7.1358	0.0000	7.1358			0.0000			0.0000
Off-Road	5.4534	57.1174	45.5209	0.1004		2.3502	2.3502		2.1621	2.1621		9,723.5530	9,723.5530	3.1448		9,802.1729
Total	5.4534	57.1174	45.5209	0.1004	16.8164	2.3502	19.1666	7.1358	2.1621	9.2979		9,723.5530	9,723.5530	3.1448		9,802.1729

Vega SES 4 Solar Energy Storage Project - Imperial County, Winter

EMFAC Off-Model Adjustment Factors for Gasoline Light Duty Vehicle to Account for the SAFE Vehicle Rule Not Applied

3.3 Grading - 2023

Unmitigated Construction Off-Site

	ROG	NOx	CO	SO2	Fugitive PM10	Exhaust PM10	PM10 Total	Fugitive PM2.5	Exhaust PM2.5	PM2.5 Total	Bio- CO2	NBio- CO2	Total CO2	CH4	N2O	CO2e
Category	lb/day										lb/day					
Hauling	0.0000	0.0000	0.0000	0.0000	0.0000	0.0000	0.0000	0.0000	0.0000	0.0000		0.0000	0.0000	0.0000	0.0000	0.0000
Vendor	0.0195	0.4491	0.1329	3.0900e-003	119.2980	5.2600e-003	119.3033	11.9190	5.0300e-003	11.9240		324.5098	324.5098	9.0000e-004	0.0445	337.7815
Worker	0.1429	0.0921	0.9504	2.3300e-003	63.0131	1.4600e-003	63.0146	6.3326	1.3500e-003	6.3339		235.3385	235.3385	8.8400e-003	8.3400e-003	238.0445
Total	0.1624	0.5412	1.0832	5.4200e-003	182.3111	6.7200e-003	182.3179	18.2516	6.3800e-003	18.2580		559.8483	559.8483	9.7400e-003	0.0528	575.8260

Mitigated Construction On-Site

	ROG	NOx	CO	SO2	Fugitive PM10	Exhaust PM10	PM10 Total	Fugitive PM2.5	Exhaust PM2.5	PM2.5 Total	Bio- CO2	NBio- CO2	Total CO2	CH4	N2O	CO2e
Category	lb/day										lb/day					
Fugitive Dust					6.5584	0.0000	6.5584	2.7829	0.0000	2.7829			0.0000			0.0000
Off-Road	5.4534	57.1174	45.5209	0.1004		2.3502	2.3502		2.1621	2.1621	0.0000	9,723.5530	9,723.5530	3.1448		9,802.1729
Total	5.4534	57.1174	45.5209	0.1004	6.5584	2.3502	8.9086	2.7829	2.1621	4.9451	0.0000	9,723.5530	9,723.5530	3.1448		9,802.1729

Vega SES 4 Solar Energy Storage Project - Imperial County, Winter

EMFAC Off-Model Adjustment Factors for Gasoline Light Duty Vehicle to Account for the SAFE Vehicle Rule Not Applied

3.3 Grading - 2023

Mitigated Construction Off-Site

	ROG	NOx	CO	SO2	Fugitive PM10	Exhaust PM10	PM10 Total	Fugitive PM2.5	Exhaust PM2.5	PM2.5 Total	Bio- CO2	NBio- CO2	Total CO2	CH4	N2O	CO2e
Category	lb/day										lb/day					
Hauling	0.0000	0.0000	0.0000	0.0000	0.0000	0.0000	0.0000	0.0000	0.0000	0.0000		0.0000	0.0000	0.0000	0.0000	0.0000
Vendor	0.0195	0.4491	0.1329	3.0900e-003	11.0155	5.2600e-003	11.0208	1.1123	5.0300e-003	1.1173		324.5098	324.5098	9.0000e-004	0.0445	337.7815
Worker	0.1429	0.0921	0.9504	2.3300e-003	6.0291	1.4600e-003	6.0306	0.6455	1.3500e-003	0.6469		235.3385	235.3385	8.8400e-003	8.3400e-003	238.0445
Total	0.1624	0.5412	1.0832	5.4200e-003	17.0447	6.7200e-003	17.0514	1.7578	6.3800e-003	1.7642		559.8483	559.8483	9.7400e-003	0.0528	575.8260

3.4 Building Construction - 2023

Unmitigated Construction On-Site

	ROG	NOx	CO	SO2	Fugitive PM10	Exhaust PM10	PM10 Total	Fugitive PM2.5	Exhaust PM2.5	PM2.5 Total	Bio- CO2	NBio- CO2	Total CO2	CH4	N2O	CO2e
Category	lb/day										lb/day					
Off-Road	2.9498	30.0468	36.2147	0.0564		1.4917	1.4917		1.3755	1.3755		5,412.1870	5,412.1870	1.7201		5,455.1901
Total	2.9498	30.0468	36.2147	0.0564		1.4917	1.4917		1.3755	1.3755		5,412.1870	5,412.1870	1.7201		5,455.1901

Vega SES 4 Solar Energy Storage Project - Imperial County, Winter

EMFAC Off-Model Adjustment Factors for Gasoline Light Duty Vehicle to Account for the SAFE Vehicle Rule Not Applied

3.4 Building Construction - 2023

Unmitigated Construction Off-Site

	ROG	NOx	CO	SO2	Fugitive PM10	Exhaust PM10	PM10 Total	Fugitive PM2.5	Exhaust PM2.5	PM2.5 Total	Bio- CO2	NBio- CO2	Total CO2	CH4	N2O	CO2e
Category	lb/day										lb/day					
Hauling	0.0000	0.0000	0.0000	0.0000	0.0000	0.0000	0.0000	0.0000	0.0000	0.0000		0.0000	0.0000	0.0000	0.0000	0.0000
Vendor	0.0195	0.4491	0.1329	3.0900e-003	119.2980	5.2600e-003	119.3033	11.9190	5.0300e-003	11.9240		324.5098	324.5098	9.0000e-004	0.0445	337.7815
Worker	1.8807	1.2119	12.5052	0.0306	829.1202	0.0192	829.1395	83.3236	0.0177	83.3413		3,096.5589	3,096.5589	0.1163	0.1097	3,132.1648
Total	1.9002	1.6610	12.6380	0.0337	948.4182	0.0245	948.4427	95.2426	0.0227	95.2653		3,421.0687	3,421.0687	0.1172	0.1542	3,469.9463

Mitigated Construction On-Site

	ROG	NOx	CO	SO2	Fugitive PM10	Exhaust PM10	PM10 Total	Fugitive PM2.5	Exhaust PM2.5	PM2.5 Total	Bio- CO2	NBio- CO2	Total CO2	CH4	N2O	CO2e
Category	lb/day										lb/day					
Off-Road	2.9498	30.0468	36.2147	0.0564		1.4917	1.4917		1.3755	1.3755	0.0000	5,412.1870	5,412.1870	1.7201		5,455.1901
Total	2.9498	30.0468	36.2147	0.0564		1.4917	1.4917		1.3755	1.3755	0.0000	5,412.1870	5,412.1870	1.7201		5,455.1901

Vega SES 4 Solar Energy Storage Project - Imperial County, Winter

EMFAC Off-Model Adjustment Factors for Gasoline Light Duty Vehicle to Account for the SAFE Vehicle Rule Not Applied

3.4 Building Construction - 2023

Mitigated Construction Off-Site

	ROG	NOx	CO	SO2	Fugitive PM10	Exhaust PM10	PM10 Total	Fugitive PM2.5	Exhaust PM2.5	PM2.5 Total	Bio- CO2	NBio- CO2	Total CO2	CH4	N2O	CO2e
Category	lb/day										lb/day					
Hauling	0.0000	0.0000	0.0000	0.0000	0.0000	0.0000	0.0000	0.0000	0.0000	0.0000		0.0000	0.0000	0.0000	0.0000	0.0000
Vendor	0.0195	0.4491	0.1329	3.0900e-003	11.0155	5.2600e-003	11.0208	1.1123	5.0300e-003	1.1173		324.5098	324.5098	9.0000e-004	0.0445	337.7815
Worker	1.8807	1.2119	12.5052	0.0306	79.3306	0.0192	79.3498	8.4939	0.0177	8.5116		3,096.5589	3,096.5589	0.1163	0.1097	3,132.1648
Total	1.9002	1.6610	12.6380	0.0337	90.3461	0.0245	90.3706	9.6062	0.0227	9.6289		3,421.0687	3,421.0687	0.1172	0.1542	3,469.9463

3.4 Building Construction - 2024

Unmitigated Construction On-Site

	ROG	NOx	CO	SO2	Fugitive PM10	Exhaust PM10	PM10 Total	Fugitive PM2.5	Exhaust PM2.5	PM2.5 Total	Bio- CO2	NBio- CO2	Total CO2	CH4	N2O	CO2e
Category	lb/day										lb/day					
Off-Road	2.8438	28.6031	36.2160	0.0564		1.3862	1.3862		1.2785	1.2785		5,412.5100	5,412.5100	1.7202		5,455.5157
Total	2.8438	28.6031	36.2160	0.0564		1.3862	1.3862		1.2785	1.2785		5,412.5100	5,412.5100	1.7202		5,455.5157

Vega SES 4 Solar Energy Storage Project - Imperial County, Winter

EMFAC Off-Model Adjustment Factors for Gasoline Light Duty Vehicle to Account for the SAFE Vehicle Rule Not Applied

3.4 Building Construction - 2024

Unmitigated Construction Off-Site

	ROG	NOx	CO	SO2	Fugitive PM10	Exhaust PM10	PM10 Total	Fugitive PM2.5	Exhaust PM2.5	PM2.5 Total	Bio- CO2	NBio- CO2	Total CO2	CH4	N2O	CO2e
Category	lb/day										lb/day					
Hauling	0.0000	0.0000	0.0000	0.0000	0.0000	0.0000	0.0000	0.0000	0.0000	0.0000		0.0000	0.0000	0.0000	0.0000	0.0000
Vendor	0.0185	0.4471	0.1245	3.0400e-003	119.2980	5.2400e-003	119.3032	11.9190	5.0200e-003	11.9240		320.1130	320.1130	8.5000e-004	0.0436	333.1296
Worker	1.7515	1.0739	11.5538	0.0297	829.1202	0.0182	829.1384	83.3236	0.0168	83.3404		3,004.5087	3,004.5087	0.1053	0.1013	3,037.3390
Total	1.7700	1.5211	11.6783	0.0328	948.4182	0.0235	948.4417	95.2426	0.0218	95.2644		3,324.6217	3,324.6217	0.1062	0.1449	3,370.4686

Mitigated Construction On-Site

	ROG	NOx	CO	SO2	Fugitive PM10	Exhaust PM10	PM10 Total	Fugitive PM2.5	Exhaust PM2.5	PM2.5 Total	Bio- CO2	NBio- CO2	Total CO2	CH4	N2O	CO2e
Category	lb/day										lb/day					
Off-Road	2.8438	28.6031	36.2160	0.0564		1.3862	1.3862		1.2785	1.2785	0.0000	5,412.5100	5,412.5100	1.7202		5,455.5157
Total	2.8438	28.6031	36.2160	0.0564		1.3862	1.3862		1.2785	1.2785	0.0000	5,412.5100	5,412.5100	1.7202		5,455.5157

Vega SES 4 Solar Energy Storage Project - Imperial County, Winter

EMFAC Off-Model Adjustment Factors for Gasoline Light Duty Vehicle to Account for the SAFE Vehicle Rule Not Applied

3.4 Building Construction - 2024

Mitigated Construction Off-Site

	ROG	NOx	CO	SO2	Fugitive PM10	Exhaust PM10	PM10 Total	Fugitive PM2.5	Exhaust PM2.5	PM2.5 Total	Bio- CO2	NBio- CO2	Total CO2	CH4	N2O	CO2e
Category	lb/day										lb/day					
Hauling	0.0000	0.0000	0.0000	0.0000	0.0000	0.0000	0.0000	0.0000	0.0000	0.0000		0.0000	0.0000	0.0000	0.0000	0.0000
Vendor	0.0185	0.4471	0.1245	3.0400e-003	11.0155	5.2400e-003	11.0208	1.1123	5.0200e-003	1.1173		320.1130	320.1130	8.5000e-004	0.0436	333.1296
Worker	1.7515	1.0739	11.5538	0.0297	79.3306	0.0182	79.3488	8.4939	0.0168	8.5107		3,004.5087	3,004.5087	0.1053	0.1013	3,037.3390
Total	1.7700	1.5211	11.6783	0.0328	90.3461	0.0235	90.3696	9.6062	0.0218	9.6280		3,324.6217	3,324.6217	0.1062	0.1449	3,370.4686

4.0 Operational Detail - Mobile

4.1 Mitigation Measures Mobile

Vega SES 4 Solar Energy Storage Project - Imperial County, Winter

EMFAC Off-Model Adjustment Factors for Gasoline Light Duty Vehicle to Account for the SAFE Vehicle Rule Not Applied

	ROG	NOx	CO	SO2	Fugitive PM10	Exhaust PM10	PM10 Total	Fugitive PM2.5	Exhaust PM2.5	PM2.5 Total	Bio- CO2	NBio- CO2	Total CO2	CH4	N2O	CO2e
Category	lb/day										lb/day					
Mitigated	0.0206	0.0393	0.2405	5.6000e-004	4.8460	4.4000e-004	4.8464	0.4922	4.1000e-004	0.4927		57.0593	57.0593	2.6600e-003	2.8300e-003	57.9690
Unmitigated	0.0206	0.0393	0.2405	5.6000e-004	4.8460	4.4000e-004	4.8464	0.4922	4.1000e-004	0.4927		57.0593	57.0593	2.6600e-003	2.8300e-003	57.9690

4.2 Trip Summary Information

Land Use	Average Daily Trip Rate			Unmitigated	Mitigated
	Weekday	Saturday	Sunday	Annual VMT	Annual VMT
Refrigerated Warehouse-No Rail	2.96	0.00	0.00	10,455	10,455
Refrigerated Warehouse-No Rail	2.96	0.00	0.00	10,455	10,455
Other Non-Asphalt Surfaces	0.00	0.00	0.00		
Other Non-Asphalt Surfaces	0.00	0.00	0.00		
Total	5.92	0.00	0.00	20,910	20,910

4.3 Trip Type Information

Land Use	Miles			Trip %			Trip Purpose %		
	H-W or C-W	H-S or C-C	H-O or C-NW	H-W or C-W	H-S or C-C	H-O or C-NW	Primary	Diverted	Pass-by
Refrigerated Warehouse-No	16.40	9.50	11.90	59.00	0.00	41.00	92	5	3
Refrigerated Warehouse-No	16.40	9.50	11.90	59.00	0.00	41.00	92	5	3
Other Non-Asphalt Surfaces	16.40	9.50	11.90	0.00	0.00	0.00	0	0	0
Other Non-Asphalt Surfaces	16.40	9.50	11.90	0.00	0.00	0.00	0	0	0

4.4 Fleet Mix

Vega SES 4 Solar Energy Storage Project - Imperial County, Winter

EMFAC Off-Model Adjustment Factors for Gasoline Light Duty Vehicle to Account for the SAFE Vehicle Rule Not Applied

Land Use	LDA	LDT1	LDT2	MDV	LHD1	LHD2	MHD	HHD	OBUS	UBUS	MCY	SBUS	MH
Refrigerated Warehouse-No Rail	0.521846	0.059402	0.180067	0.151114	0.027614	0.006908	0.008276	0.016396	0.000918	0.000121	0.022925	0.000779	0.003633
Other Non-Asphalt Surfaces	0.521846	0.059402	0.180067	0.151114	0.027614	0.006908	0.008276	0.016396	0.000918	0.000121	0.022925	0.000779	0.003633

5.0 Energy Detail

Historical Energy Use: N

5.1 Mitigation Measures Energy

Percent of Electricity Use Generated with Renewable Energy

	ROG	NOx	CO	SO2	Fugitive PM10	Exhaust PM10	PM10 Total	Fugitive PM2.5	Exhaust PM2.5	PM2.5 Total	Bio- CO2	NBio- CO2	Total CO2	CH4	N2O	CO2e
Category	lb/day										lb/day					
NaturalGas Mitigated	0.2663	2.4210	2.0337	0.0145		0.1840	0.1840		0.1840	0.1840		2,905.2168	2,905.2168	0.0557	0.0533	2,922.4811
NaturalGas Unmitigated	0.2663	2.4210	2.0337	0.0145		0.1840	0.1840		0.1840	0.1840		2,905.2168	2,905.2168	0.0557	0.0533	2,922.4811

Vega SES 4 Solar Energy Storage Project - Imperial County, Winter

EMFAC Off-Model Adjustment Factors for Gasoline Light Duty Vehicle to Account for the SAFE Vehicle Rule Not Applied

5.2 Energy by Land Use - NaturalGas

Unmitigated

	NaturalGas Use	ROG	NOx	CO	SO2	Fugitive PM10	Exhaust PM10	PM10 Total	Fugitive PM2.5	Exhaust PM2.5	PM2.5 Total	Bio- CO2	NBio- CO2	Total CO2	CH4	N2O	CO2e
Land Use	kBTU/yr	lb/day										lb/day					
Other Non-Asphalt Surfaces	0	0.0000	0.0000	0.0000	0.0000		0.0000	0.0000		0.0000	0.0000		0.0000	0.0000	0.0000	0.0000	0.0000
Refrigerated Warehouse-No Rail	12347.2	0.2663	2.4210	2.0337	0.0145		0.1840	0.1840		0.1840	0.1840		2,905.2168	2,905.2168	0.0557	0.0533	2,922.4811
Total		0.2663	2.4210	2.0337	0.0145		0.1840	0.1840		0.1840	0.1840		2,905.2168	2,905.2168	0.0557	0.0533	2,922.4811

Mitigated

	NaturalGas Use	ROG	NOx	CO	SO2	Fugitive PM10	Exhaust PM10	PM10 Total	Fugitive PM2.5	Exhaust PM2.5	PM2.5 Total	Bio- CO2	NBio- CO2	Total CO2	CH4	N2O	CO2e
Land Use	kBTU/yr	lb/day										lb/day					
Other Non-Asphalt Surfaces	0	0.0000	0.0000	0.0000	0.0000		0.0000	0.0000		0.0000	0.0000		0.0000	0.0000	0.0000	0.0000	0.0000
Refrigerated Warehouse-No Rail	12.3472	0.2663	2.4210	2.0337	0.0145		0.1840	0.1840		0.1840	0.1840		2,905.2168	2,905.2168	0.0557	0.0533	2,922.4811
Total		0.2663	2.4210	2.0337	0.0145		0.1840	0.1840		0.1840	0.1840		2,905.2168	2,905.2168	0.0557	0.0533	2,922.4811

6.0 Area Detail

Vega SES 4 Solar Energy Storage Project - Imperial County, Winter

EMFAC Off-Model Adjustment Factors for Gasoline Light Duty Vehicle to Account for the SAFE Vehicle Rule Not Applied

6.1 Mitigation Measures Area

	ROG	NOx	CO	SO2	Fugitive PM10	Exhaust PM10	PM10 Total	Fugitive PM2.5	Exhaust PM2.5	PM2.5 Total	Bio- CO2	NBio- CO2	Total CO2	CH4	N2O	CO2e
Category	lb/day										lb/day					
Mitigated	13.5919	5.8000e-004	0.0638	0.0000		2.3000e-004	2.3000e-004		2.3000e-004	2.3000e-004		0.1367	0.1367	3.6000e-004		0.1457
Unmitigated	13.5919	5.8000e-004	0.0638	0.0000		2.3000e-004	2.3000e-004		2.3000e-004	2.3000e-004		0.1367	0.1367	3.6000e-004		0.1457

6.2 Area by SubCategory

Unmitigated

	ROG	NOx	CO	SO2	Fugitive PM10	Exhaust PM10	PM10 Total	Fugitive PM2.5	Exhaust PM2.5	PM2.5 Total	Bio- CO2	NBio- CO2	Total CO2	CH4	N2O	CO2e
SubCategory	lb/day										lb/day					
Architectural Coating	2.9065					0.0000	0.0000		0.0000	0.0000			0.0000			0.0000
Consumer Products	10.6795					0.0000	0.0000		0.0000	0.0000			0.0000			0.0000
Landscaping	5.9100e-003	5.8000e-004	0.0638	0.0000		2.3000e-004	2.3000e-004		2.3000e-004	2.3000e-004		0.1367	0.1367	3.6000e-004		0.1457
Total	13.5919	5.8000e-004	0.0638	0.0000		2.3000e-004	2.3000e-004		2.3000e-004	2.3000e-004		0.1367	0.1367	3.6000e-004		0.1457

Vega SES 4 Solar Energy Storage Project - Imperial County, Winter

EMFAC Off-Model Adjustment Factors for Gasoline Light Duty Vehicle to Account for the SAFE Vehicle Rule Not Applied

6.2 Area by SubCategory

Mitigated

	ROG	NOx	CO	SO2	Fugitive PM10	Exhaust PM10	PM10 Total	Fugitive PM2.5	Exhaust PM2.5	PM2.5 Total	Bio- CO2	NBio- CO2	Total CO2	CH4	N2O	CO2e
SubCategory	lb/day										lb/day					
Architectural Coating	2.9065					0.0000	0.0000		0.0000	0.0000			0.0000			0.0000
Consumer Products	10.6795					0.0000	0.0000		0.0000	0.0000			0.0000			0.0000
Landscaping	5.9100e-003	5.8000e-004	0.0638	0.0000		2.3000e-004	2.3000e-004		2.3000e-004	2.3000e-004		0.1367	0.1367	3.6000e-004		0.1457
Total	13.5919	5.8000e-004	0.0638	0.0000		2.3000e-004	2.3000e-004		2.3000e-004	2.3000e-004		0.1367	0.1367	3.6000e-004		0.1457

7.0 Water Detail

7.1 Mitigation Measures Water

8.0 Waste Detail

8.1 Mitigation Measures Waste

9.0 Operational Offroad

Equipment Type	Number	Hours/Day	Days/Year	Horse Power	Load Factor	Fuel Type
Other Construction Equipment	3	8.00	8	172	0.42	Diesel
Off-Highway Trucks	1	2.00	8	402	0.38	Diesel

Vega SES 4 Solar Energy Storage Project - Imperial County, Winter

EMFAC Off-Model Adjustment Factors for Gasoline Light Duty Vehicle to Account for the SAFE Vehicle Rule Not Applied

UnMitigated/Mitigated

	ROG	NOx	CO	SO2	Fugitive PM10	Exhaust PM10	PM10 Total	Fugitive PM2.5	Exhaust PM2.5	PM2.5 Total	Bio- CO2	NBio- CO2	Total CO2	CH4	N2O	CO2e
Equipment Type	lb/day										lb/day					
Off-Highway Trucks	0.1266	0.8964	0.8262	3.3200e-003		0.0324	0.0324		0.0298	0.0298	0.0000	321.5720	321.5720	0.1040		324.1721
Other Construction Equipment	1.0338	10.2004	11.8763	0.0183		0.5310	0.5310		0.4885	0.4885	0.0000	1,775.1278	1,775.1278	0.5741		1,789.4806
Total	1.1604	11.0968	12.7025	0.0217		0.5634	0.5634		0.5184	0.5184	0.0000	2,096.6998	2,096.6998	0.6781		2,113.6527

10.0 Stationary Equipment

Fire Pumps and Emergency Generators

Equipment Type	Number	Hours/Day	Hours/Year	Horse Power	Load Factor	Fuel Type
----------------	--------	-----------	------------	-------------	-------------	-----------

Boilers

Equipment Type	Number	Heat Input/Day	Heat Input/Year	Boiler Rating	Fuel Type
----------------	--------	----------------	-----------------	---------------	-----------

User Defined Equipment

Equipment Type	Number
----------------	--------

11.0 Vegetation

Renewable Energy Emissions Displacement

CRITERIA AIR POLLUTANT DISPLACEMENT

PC ORIGINAL PKG

Table A-1. Renewable Energy Generator Specifications

Megawatt Project	100
Operational Time ¹	25
Annual Hours of Generation ¹	2,190
Annual Kilowatt Hours	219,000,000
Heat Rate ²	9,313
Btu Displaced ³	2,039,547,000,000

Notes:

¹ The Project is assumed to generate electricity 25 percent of the time available (2,190 hours annually).

² Heat Rate indicate the energy generator efficiency of existing fossil-fuel based energy generators. The heat rate of a power plant measures the amount of fuel used to generate one unit of electricity. Power plants with lower heat rates are more efficient than plants with higher heat rates. The CEC's "Updated Thermal Power Plant Efficiency Measures and Operational Characteristics for Production Cost Modeling" (2019) estimates heat rates and operating ranges for thermal power plants supplying energy to California. the average heat rate of power plant types are as follows:

Table A-2. Heat Rates

Steam Boiler Fueled by Coal:	10,800
Steam Boiler Fueled by Natural Gas:	10,200
Gas Turbine:	10,100
Combined Natural Gas Boiler & Turbine:	7,640

Omitting steam boilers fueled by coal since so little of California's energy is derived from coal, the average heat rate =

9313

³ The annual kilowatt hours multiplied by the average heat rate of existing fossil fuel based energy generators equals the amount of Btu displaced from fossil fuel production, as shown in Table A-3.

Table A-3. Btu Displacement

Annual Kilowatt Hours	219,000,000
Average Heat Rate	9,313
Btu Displaced from Fossil Fuel Based Energy Production	2,039,547,000,000

Energy consumption in California is predominately derived from natural gas, followed by renewables, nuclear, unspecified nonrenewable sources, and coal, as shown in Table A-4.

Table A-4. California Energy Mix (percentages)

Natural Gas	37.06
Coal	2.74
Renewables (not including hydroelectric generators)	33.09
Nuclear	9.33
Unspecified nonrenewable sources	5.36

Source: California Energy Commission. 2021. "2020 Total System Electric Generation." <https://www.energy.ca.gov/data-reports/energy-almanac/california-electricity-data/2020-total-system-electric-generation>

For the purposes of this analysis, the percentage of California energy derived from natural gas is added to unspecified nonrenewable sources. Table A-5 identifies the displaced Btu attributable to displaced natural gas and displaced coal.

Table A-5. Btu Displacement by Fossil Fuel Type - Annually

Natural Gas & Unspecified Nonrenewable Sources	865,175,837,400
Coal	55,883,587,800

The heat content of coal is assumed at 24 million Btu per ton of coal burned. Table A-6 shows the tons of displaced burned coal based on this heat content.

Table A-6. Tons of Displaced Burned Coal - Annually

Displaced Coal Burn	2,328
---------------------	-------

Table A-7. Emissions Displacement - Tons per Year⁴

Natural Gas	
Nitrogen Oxide	2.14
Carbon Monoxide	0.65
Coarse Particulate Matter	2.03
Fine Particulate Matter	0.82
Sulfur Dioxide	1.47

Coal	
Nitrogen Oxide	13.97
Carbon Monoxide	0.58
Coarse Particulate Matter	0.10
Fine Particulate Matter	0.07
Sulfur Dioxide	0.66

Table A-8. Total Combined Emissions Displacement - Tons per Year

Natural Gas & Coal	
Nitrogen Oxide	16.11
Carbon Monoxide	1.23
Coarse Particulate Matter	2.13
Fine Particulate Matter	0.89
Sulfur Dioxide	2.13

Table A-9. Total Combined Emissions Displacement over the Life of the Project (30 years) - Tons per Year

Natural Gas & Coal	
Nitrogen Oxide	483.37
Carbon Monoxide	36.93
Coarse Particulate Matter	63.93
Fine Particulate Matter	26.75
Sulfur Dioxide	64.03

⁴Source: Displaced emissions calculated by ECORP Consulting using U.S. EPA's AP-42 Fifth Edition Compilation of Air Emissions Factors 1995; 2015.

GREENHOUSE GAS EMISSIONS DISPLACEMENT

PC ORIGINAL PKG

Table B-1. Renewable Energy Generator Specifications

Megawatt Project	100
Operational Time ¹	25
Annual Hours of Generation ¹	2,190
Annual Kilowatt Hours	219,000,000
Heat Rate ²	9,313
Btu Displaced ³	2,039,547,000,000

Notes:

¹ The Project is assumed to generate electricity 25 percent of the time available (2,190 hours annually).

² Heat Rate indicate the energy generator efficiency of existing fossil-fuel based energy generators. The heat rate of a power plant measures the amount of fuel used to generate one unit of electricity. Power plants with lower heat rates are more efficient than plants with higher heat rates. The CEC's "Updated Thermal Power Plant Efficiency Measures and Operational Characteristics for Production Cost Modeling" (2019) estimates heat rates and operating ranges for thermal power plants supplying energy to California. the average heat rate of power plant types are as follows:

Table B-2. Heat Rates

Steam Boiler Fueled by Coal:	10,800
Steam Boiler Fueled by Natural Gas:	10,200
Gas Turbine:	10,100
Combined Natural Gas Boiler & Turbine:	7,640

Omitting steam boilers fueled by coal since so little of California's energy is derived from coal, the average heat rate =

9313

³ The annual kilowatt hours multiplied by the average heat rate of existing fossil fuel based energy generators equals the amount of Btu displaced from fossil fuel production, as shown in Table A-3.

Table B-3. Btu Displacement

Annual Kilowatt Hours	219,000,000
Average Heat Rate	9,313
Btu Displaced from Fossil Fuel Based Energy Production	2,039,547,000,000

Energy consumption in California is predominately derived from natural gas, followed by renewables, nuclear, unspecified nonrenewable sources, and coal, as shown in Table A-4.

Table B-4. California Energy Mix (percentages)

Natural Gas	37.06
Coal	2.74
Renewables (not including hydroelectric generators)	33.09
Nuclear	9.33
Unspecified nonrenewable sources	5.36

Source: California Energy Commission. 2021. "2020 Total System Electric Generation." <https://www.energy.ca.gov/data-reports/energy-almanac/california-electricity-data/2020-total-system-electric-generation>

For the purposes of this analysis, the percentage of California energy derived from natural gas is added to unspecified nonrenewable sources. Table A-5 identifies the displaced Btu attributable to displaced natural gas and displaced coal.

Table B-5. Btu Displacement by Fossil Fuel Type - Annually

Natural Gas & Unspecified Nonrenewable Sources	865,175,837,400
Coal	55,883,587,800

The heat content of coal is assumed at 24 million Btu per ton of coal burned. Table A-6 shows the tons of displaced burned coal based on this heat content.

Table B-6. Tons of Displaced Burned Coal - Annually

Displaced Coal Burn	2,328
---------------------	-------

Table B-7. Emissions Displacement - Metric Tons per Year⁴

Natural Gas	
Carbon Dioxide	47,585
Methane	0.000
Nitrous Oxide	0.000
Carbon Dioxide Equivalents	47,585

Coal	
Carbon Dioxide	5626
Methane	0.037
Nitrous Oxide	0.028
Carbon Dioxide Equivalents	5635

Table B-8. Total Combined Emissions Displacement - Metric Tons per Year

Natural Gas & Coal	
Carbon Dioxide	53,210
Methane	0.037
Nitrous Oxide	0.028
Carbon Dioxide Equivalents	53,220

Table B-9. Total Combined Emissions Displacement over the Life of the Project (30 years) - Metric Tons per Year

Natural Gas & Coal	
Carbon Dioxide	1,596,309
Methane	1.118
Nitrous Oxide	0.838
Carbon Dioxide Equivalents	1,596,596

⁴Source: Displaced emissions calculated by ECORP Consulting using U.S. EPA's AP-42 Fifth Edition Compilation of Air Emissions Factors 1995; 2015.

Attachment C – CalEEMod Output Files Greenhouse Gas Emissions

Vega SES 4 Solar Energy Storage Project - Imperial County, Annual

EMFAC Off-Model Adjustment Factors for Gasoline Light Duty Vehicle to Account for the SAFE Vehicle Rule Not Applied

**Vega SES 4 Solar Energy Storage Project
Imperial County, Annual**

1.0 Project Characteristics

1.1 Land Usage

Land Uses	Size	Metric	Lot Acreage	Floor Surface Area	Population
Other Non-Asphalt Surfaces	447.00	Acre	447.00	19,471,320.00	0
Refrigerated Warehouse-No Rail	87.12	1000sqft	2.00	87,120.00	0
Refrigerated Warehouse-No Rail	87.12	1000sqft	2.00	87,120.00	0
Other Non-Asphalt Surfaces	3.50	Acre	3.50	152,460.00	0

1.2 Other Project Characteristics

Urbanization	Rural	Wind Speed (m/s)	3.4	Precipitation Freq (Days)	12
Climate Zone	15			Operational Year	2023
Utility Company	Imperial Irrigation District				
CO2 Intensity (lb/MWhr)	189.98	CH4 Intensity (lb/MWhr)	0.033	N2O Intensity (lb/MWhr)	0.004

1.3 User Entered Comments & Non-Default Data

Project Characteristics -

Land Use - Land Uses account for 447 acres of solar field, 2 acres of BESS, 2 acres of Substation, and 3.5 acres of Staging/Parking Area

Construction Phase - Construction timing per Project Applicant

Off-road Equipment - Construction equipment per Project applicant. Plate compactor = pile driver.

Off-road Equipment - Ibid

Off-road Equipment - Construction equipment per Project applicant.

Trips and VMT - Maximun 500 worker commute trips per Traffic Study. 20.25 miles added to vendor route for extended access along border.

On-road Fugitive Dust - 89% paved roads for worker commutes [1.15 m dirt roads / 10.2 m trip length default = 89% paved roads]. Traffic Study identifies worker commute routes north of Staging/Parking Area as 100% paved. 37% paved for vendor/equipment hauling trips. Trips require additional 20.25 miles of distance on dirt roadway.

PC ORIGINAL PKG

Vega SES 4 Solar Energy Storage Project - Imperial County, Annual

EMFAC Off-Model Adjustment Factors for Gasoline Light Duty Vehicle to Account for the SAFE Vehicle Rule Not Applied

Grading -

Vehicle Trips - Maximum daily trips = 6 per Traffic Study

Road Dust - 92% paved roads for operational worker commutes [1.15 m dirt roads / 14.55 m trip length default weighted average = 92% paved roads].

Energy Use - Solar facility- no operational energy use.

Water And Wastewater - Water use being kept for light industrial land use as the solar panels may need to be cleaned.

Solid Waste - No solid waste- solar facility.

Construction Off-road Equipment Mitigation - Mitigation measure AQ-1 accounted. PM Reduction value for applying soil stabilizers to unpaved roadways per communication with ICAPCD (Monica Soucier via email correspondence).

Mobile Land Use Mitigation -

Energy Mitigation -

Operational Off-Road Equipment - Onsite maintenance expected 4 times annually.

Table Name	Column Name	Default Value	New Value
tblConstDustMitigation	WaterUnpavedRoadVehicleSpeed	40	15
tblConstructionPhase	NumDays	7,750.00	286.00
tblConstructionPhase	NumDays	775.00	66.00
tblConstructionPhase	NumDays	300.00	33.00
tblConstructionPhase	PhaseEndDate	9/30/2055	7/25/2024
tblConstructionPhase	PhaseEndDate	1/15/2026	6/21/2023
tblConstructionPhase	PhaseEndDate	1/26/2023	3/21/2023
tblConstructionPhase	PhaseStartDate	1/16/2026	6/22/2023
tblConstructionPhase	PhaseStartDate	1/27/2023	3/22/2023
tblConstructionPhase	PhaseStartDate	12/3/2021	2/3/2023
tblOffRoadEquipment	LoadFactor	0.36	0.36
tblOffRoadEquipment	LoadFactor	0.40	0.40
tblOffRoadEquipment	LoadFactor	0.42	0.42
tblOffRoadEquipment	LoadFactor	0.36	0.36
tblOffRoadEquipment	LoadFactor	0.50	0.50
tblOffRoadEquipment	LoadFactor	0.38	0.38
tblOffRoadEquipment	OffRoadEquipmentType	PC ORIGINAL PKG	Rubber Tired Loaders

Vega SES 4 Solar Energy Storage Project - Imperial County, Annual

EMFAC Off-Model Adjustment Factors for Gasoline Light Duty Vehicle to Account for the SAFE Vehicle Rule Not Applied

tblOffRoadEquipment	OffRoadEquipmentType		Rough Terrain Forklifts
tblOffRoadEquipment	OffRoadEquipmentType		Pavers
tblOffRoadEquipment	OffRoadEquipmentType		Paving Equipment
tblOffRoadEquipment	OffRoadEquipmentType		Plate Compactors
tblOffRoadEquipment	OffRoadEquipmentType		Trenchers
tblOffRoadEquipment	OffRoadEquipmentType		Rollers
tblOffRoadEquipment	OffRoadEquipmentUnitAmount	2.00	4.00
tblOffRoadEquipment	OffRoadEquipmentUnitAmount	3.00	0.00
tblOffRoadEquipment	OffRoadEquipmentUnitAmount	1.00	0.00
tblOffRoadEquipment	OffRoadEquipmentUnitAmount	1.00	3.00
tblOffRoadEquipment	OffRoadEquipmentUnitAmount	1.00	2.00
tblOffRoadEquipment	OffRoadEquipmentUnitAmount	3.00	0.00
tblOffRoadEquipment	OffRoadEquipmentUnitAmount	3.00	4.00
tblOffRoadEquipment	OffRoadEquipmentUnitAmount	2.00	4.00
tblOffRoadEquipment	OffRoadEquipmentUnitAmount	4.00	2.00
tblOffRoadEquipment	OffRoadEquipmentUnitAmount	1.00	0.00
tblOnRoadDust	VendorPercentPave	50.00	37.00
tblOnRoadDust	VendorPercentPave	50.00	37.00
tblOnRoadDust	VendorPercentPave	50.00	37.00
tblOnRoadDust	WorkerPercentPave	50.00	89.00
tblOnRoadDust	WorkerPercentPave	50.00	89.00
tblOnRoadDust	WorkerPercentPave	50.00	89.00
tblOperationalOffRoadEquipment	OperDaysPerYear	260.00	8.00
tblOperationalOffRoadEquipment	OperDaysPerYear	260.00	8.00
tblOperationalOffRoadEquipment	OperHoursPerDay	8.00	2.00
tblOperationalOffRoadEquipment	OperLoadFactor	0.42	0.42
tblOperationalOffRoadEquipment	OperLoadFactor	0.38	0.38
tblOperationalOffRoadEquipment	OperOffRoadEquipmentNumber	0.00	3.00
tblOperationalOffRoadEquipment	OperOffRoadEquipmentNumber	0.00	1.00

PC ORIGINAL PKG

Vega SES 4 Solar Energy Storage Project - Imperial County, Annual

EMFAC Off-Model Adjustment Factors for Gasoline Light Duty Vehicle to Account for the SAFE Vehicle Rule Not Applied

tblProjectCharacteristics	UrbanizationLevel	Urban	Rural
tblRoadDust	RoadPercentPave	50	92
tblTripsAndVMT	VendorTripLength	11.90	32.15
tblTripsAndVMT	VendorTripLength	11.90	32.15
tblTripsAndVMT	VendorTripLength	11.90	32.15
tblTripsAndVMT	VendorTripNumber	0.00	4.00
tblTripsAndVMT	VendorTripNumber	0.00	4.00
tblTripsAndVMT	VendorTripNumber	3,245.00	4.00
tblTripsAndVMT	WorkerTripNumber	8,315.00	500.00
tblVehicleTrips	ST_TR	2.12	0.00
tblVehicleTrips	SU_TR	2.12	0.00
tblVehicleTrips	WD_TR	2.12	0.03
tblWater	IndoorWaterUseRate	40,293,000.00	3,259,000.00

2.0 Emissions Summary

Vega SES 4 Solar Energy Storage Project - Imperial County, Annual

EMFAC Off-Model Adjustment Factors for Gasoline Light Duty Vehicle to Account for the SAFE Vehicle Rule Not Applied

2.1 Overall Construction

Unmitigated Construction

	ROG	NOx	CO	SO2	Fugitive PM10	Exhaust PM10	PM10 Total	Fugitive PM2.5	Exhaust PM2.5	PM2.5 Total	Bio- CO2	NBio- CO2	Total CO2	CH4	N2O	CO2e
Year	tons/yr										MT/yr					
2023	0.5427	4.2187	5.1222	0.0102	71.3792	0.1872	71.5664	7.3462	0.1724	7.5187	0.0000	904.2814	904.2814	0.2172	0.0118	913.2157
2024	0.3534	2.2421	3.6710	6.8000e-003	68.3411	0.1050	68.4461	6.8642	0.0969	6.9611	0.0000	605.1367	605.1367	0.1231	9.7000e-003	611.1068
Maximum	0.5427	4.2187	5.1222	0.0102	71.3792	0.1872	71.5664	7.3462	0.1724	7.5187	0.0000	904.2814	904.2814	0.2172	0.0118	913.2157

Mitigated Construction

	ROG	NOx	CO	SO2	Fugitive PM10	Exhaust PM10	PM10 Total	Fugitive PM2.5	Exhaust PM2.5	PM2.5 Total	Bio- CO2	NBio- CO2	Total CO2	CH4	N2O	CO2e
Year	tons/yr										MT/yr					
2023	0.5427	4.2187	5.1222	0.0102	6.9534	0.1872	7.1406	0.8066	0.1724	0.9791	0.0000	904.2807	904.2807	0.2172	0.0118	913.2149
2024	0.3534	2.2421	3.6710	6.8000e-003	6.5164	0.1050	6.6214	0.6940	0.0969	0.7909	0.0000	605.1363	605.1363	0.1231	9.7000e-003	611.1063
Maximum	0.5427	4.2187	5.1222	0.0102	6.9534	0.1872	7.1406	0.8066	0.1724	0.9791	0.0000	904.2807	904.2807	0.2172	0.0118	913.2149

Vega SES 4 Solar Energy Storage Project - Imperial County, Annual

EMFAC Off-Model Adjustment Factors for Gasoline Light Duty Vehicle to Account for the SAFE Vehicle Rule Not Applied

	ROG	NOx	CO	SO2	Fugitive PM10	Exhaust PM10	PM10 Total	Fugitive PM2.5	Exhaust PM2.5	PM2.5 Total	Bio- CO2	NBio-CO2	Total CO2	CH4	N2O	CO2e
Percent Reduction	0.00	0.00	0.00	0.00	90.36	0.00	90.17	89.44	0.00	87.78	0.00	0.00	0.00	0.00	0.00	0.00

Quarter	Start Date	End Date	Maximum Unmitigated ROG + NOX (tons/quarter)	Maximum Mitigated ROG + NOX (tons/quarter)
5	12-3-2022	3-2-2023	0.0978	0.0978
6	3-3-2023	6-2-2023	1.7160	1.7160
7	6-3-2023	9-2-2023	1.3962	1.3962
8	9-3-2023	12-2-2023	1.1934	1.1934
9	12-3-2023	3-2-2024	1.1478	1.1478
10	3-3-2024	6-2-2024	1.1522	1.1522
11	6-3-2024	9-2-2024	0.6666	0.6666
		Highest	1.7160	1.7160

Vega SES 4 Solar Energy Storage Project - Imperial County, Annual

EMFAC Off-Model Adjustment Factors for Gasoline Light Duty Vehicle to Account for the SAFE Vehicle Rule Not Applied

2.2 Overall Operational

Unmitigated Operational

	ROG	NOx	CO	SO2	Fugitive PM10	Exhaust PM10	PM10 Total	Fugitive PM2.5	Exhaust PM2.5	PM2.5 Total	Bio- CO2	NBio- CO2	Total CO2	CH4	N2O	CO2e
Category	tons/yr										MT/yr					
Area	2.4800	5.0000e-005	5.7400e-003	0.0000		2.0000e-005	2.0000e-005		2.0000e-005	2.0000e-005	0.0000	0.0112	0.0112	3.0000e-005	0.0000	0.0119
Energy	0.0486	0.4418	0.3711	2.6500e-003		0.0336	0.0336		0.0336	0.0336	0.0000	1,079.1835	1,079.1835	0.1131	0.0214	1,088.3928
Mobile	3.0600e-003	4.9800e-003	0.0337	8.0000e-005	0.6299	6.0000e-005	0.6300	0.0640	5.0000e-005	0.0640	0.0000	7.0965	7.0965	3.0000e-004	3.3000e-004	7.2024
Offroad	4.6400e-003	0.0444	0.0508	9.0000e-005		2.2500e-003	2.2500e-003		2.0700e-003	2.0700e-003	0.0000	7.6084	7.6084	2.4600e-003	0.0000	7.6699
Waste						0.0000	0.0000		0.0000	0.0000	33.2479	0.0000	33.2479	1.9649	0.0000	82.3702
Water						0.0000	0.0000		0.0000	0.0000	1.0339	3.6568	4.6907	0.1068	2.5800e-003	8.1317
Total	2.5363	0.4913	0.4614	2.8200e-003	0.6299	0.0359	0.6658	0.0640	0.0357	0.0997	34.2818	1,097.5564	1,131.8382	2.1876	0.0243	1,193.7789

Vega SES 4 Solar Energy Storage Project - Imperial County, Annual

EMFAC Off-Model Adjustment Factors for Gasoline Light Duty Vehicle to Account for the SAFE Vehicle Rule Not Applied

2.2 Overall Operational

Mitigated Operational

	ROG	NOx	CO	SO2	Fugitive PM10	Exhaust PM10	PM10 Total	Fugitive PM2.5	Exhaust PM2.5	PM2.5 Total	Bio- CO2	NBio- CO2	Total CO2	CH4	N2O	CO2e
Category	tons/yr										MT/yr					
Area	2.4800	5.0000e-005	5.7400e-003	0.0000		2.0000e-005	2.0000e-005		2.0000e-005	2.0000e-005	0.0000	0.0112	0.0112	3.0000e-005	0.0000	0.0119
Energy	0.0486	0.4418	0.3711	2.6500e-003		0.0336	0.0336		0.0336	0.0336	0.0000	480.9912	480.9912	9.2200e-003	8.8200e-003	483.8495
Mobile	3.0600e-003	4.9800e-003	0.0337	8.0000e-005	0.6299	6.0000e-005	0.6300	0.0640	5.0000e-005	0.0640	0.0000	7.0965	7.0965	3.0000e-004	3.3000e-004	7.2024
Offroad	4.6400e-003	0.0444	0.0508	9.0000e-005		2.2500e-003	2.2500e-003		2.0700e-003	2.0700e-003	0.0000	7.6084	7.6084	2.4600e-003	0.0000	7.6699
Waste						0.0000	0.0000		0.0000	0.0000	33.2479	0.0000	33.2479	1.9649	0.0000	82.3702
Water						0.0000	0.0000		0.0000	0.0000	1.0339	3.6568	4.6907	0.1068	2.5800e-003	8.1317
Total	2.5363	0.4913	0.4614	2.8200e-003	0.6299	0.0359	0.6658	0.0640	0.0357	0.0997	34.2818	499.3641	533.6459	2.0837	0.0117	589.2356

	ROG	NOx	CO	SO2	Fugitive PM10	Exhaust PM10	PM10 Total	Fugitive PM2.5	Exhaust PM2.5	PM2.5 Total	Bio- CO2	NBio- CO2	Total CO2	CH4	N2O	CO2e
Percent Reduction	0.00	0.00	0.00	0.00	0.00	0.00	0.00	0.00	0.00	0.00	0.00	54.50	52.85	4.75	51.77	50.64

3.0 Construction Detail

Construction Phase

Phase Number	Phase Name	Phase Type	Start Date	End Date	Num Days Week	Num Days	Phase Description
1	Site Preparation	Site Preparation	2/3/2023	3/21/2023	5	33	
2	Grading	Grading	3/22/2023	6/2/2023	5	66	

PC ORIGINAL PKG

Vega SES 4 Solar Energy Storage Project - Imperial County, Annual

EMFAC Off-Model Adjustment Factors for Gasoline Light Duty Vehicle to Account for the SAFE Vehicle Rule Not Applied

3	Building Construction	Building Construction	6/22/2023	7/25/2024	5	286
---	-----------------------	-----------------------	-----------	-----------	---	-----

Acres of Grading (Site Preparation Phase): 0

Acres of Grading (Grading Phase): 297

Acres of Paving: 450.5

Residential Indoor: 0; Residential Outdoor: 0; Non-Residential Indoor: 0; Non-Residential Outdoor: 0; Striped Parking Area: 0 (Architectural Coating – sqft)

OffRoad Equipment

Phase Name	Offroad Equipment Type	Amount	Usage Hours	Horse Power	Load Factor
Site Preparation	Rubber Tired Dozers	0	8.00	247	0.40
Site Preparation	Tractors/Loaders/Backhoes	2	8.00	97	0.37
Grading	Excavators	4	8.00	158	0.38
Grading	Graders	3	8.00	187	0.41
Grading	Rubber Tired Dozers	2	8.00	247	0.40
Grading	Scrapers	2	8.00	367	0.48
Grading	Tractors/Loaders/Backhoes	4	8.00	97	0.37
Building Construction	Cranes	1	7.00	231	0.29
Building Construction	Forklifts	0	8.00	89	0.20
Building Construction	Generator Sets	0	8.00	84	0.74
Site Preparation	Rubber Tired Loaders	2	8.00	203	0.36
Building Construction	Rough Terrain Forklifts	4	8.00	100	0.40
Building Construction	Pavers	1	8.00	130	0.42
Building Construction	Tractors/Loaders/Backhoes	4	7.00	97	0.37
Building Construction	Paving Equipment	2	8.00	132	0.36
Building Construction	Welders	0	8.00	46	0.45
Building Construction	Plate Compactors	4	8.00	8	0.43
Building Construction	Trenchers	2	8.00	78	0.50
Building Construction	Rollers	2	8.00	80	0.38

PC ORIGINAL PKG

Vega SES 4 Solar Energy Storage Project - Imperial County, Annual

EMFAC Off-Model Adjustment Factors for Gasoline Light Duty Vehicle to Account for the SAFE Vehicle Rule Not Applied

Trips and VMT

Phase Name	Offroad Equipment Count	Worker Trip Number	Vendor Trip Number	Hauling Trip Number	Worker Trip Length	Vendor Trip Length	Hauling Trip Length	Worker Vehicle Class	Vendor Vehicle Class	Hauling Vehicle Class
Site Preparation	4	10.00	4.00	0.00	10.20	32.15	20.00	LD_Mix	HDT_Mix	HHDT
Grading	15	38.00	4.00	0.00	10.20	32.15	20.00	LD_Mix	HDT_Mix	HHDT
Building Construction	20	500.00	4.00	0.00	10.20	32.15	20.00	LD_Mix	HDT_Mix	HHDT

3.1 Mitigation Measures Construction

Use Soil Stabilizer

Water Exposed Area

Water Unpaved Roads

Reduce Vehicle Speed on Unpaved Roads

3.2 Site Preparation - 2023

Unmitigated Construction On-Site

	ROG	NOx	CO	SO2	Fugitive PM10	Exhaust PM10	PM10 Total	Fugitive PM2.5	Exhaust PM2.5	PM2.5 Total	Bio- CO2	NBio- CO2	Total CO2	CH4	N2O	CO2e
Category	tons/yr										MT/yr					
Fugitive Dust					0.0000	0.0000	0.0000	0.0000	0.0000	0.0000	0.0000	0.0000	0.0000	0.0000	0.0000	0.0000
Off-Road	0.0140	0.1387	0.1237	3.1000e-004		5.4500e-003	5.4500e-003		5.0100e-003	5.0100e-003	0.0000	27.2477	27.2477	8.8100e-003	0.0000	27.4680
Total	0.0140	0.1387	0.1237	3.1000e-004	0.0000	5.4500e-003	5.4500e-003	0.0000	5.0100e-003	5.0100e-003	0.0000	27.2477	27.2477	8.8100e-003	0.0000	27.4680

Vega SES 4 Solar Energy Storage Project - Imperial County, Annual

EMFAC Off-Model Adjustment Factors for Gasoline Light Duty Vehicle to Account for the SAFE Vehicle Rule Not Applied

3.2 Site Preparation - 2023

Unmitigated Construction Off-Site

	ROG	NOx	CO	SO2	Fugitive PM10	Exhaust PM10	PM10 Total	Fugitive PM2.5	Exhaust PM2.5	PM2.5 Total	Bio- CO2	NBio- CO2	Total CO2	CH4	N2O	CO2e
Category	tons/yr										MT/yr					
Hauling	0.0000	0.0000	0.0000	0.0000	0.0000	0.0000	0.0000	0.0000	0.0000	0.0000	0.0000	0.0000	0.0000	0.0000	0.0000	0.0000
Vendor	3.2000e-004	7.2900e-003	2.1800e-003	5.0000e-005	1.9037	9.0000e-005	1.9038	0.1902	8.0000e-005	0.1903	0.0000	4.8556	4.8556	1.0000e-005	6.6000e-004	5.0540
Worker	6.7000e-004	3.9000e-004	4.6300e-003	1.0000e-005	0.2646	1.0000e-005	0.2647	0.0266	1.0000e-005	0.0266	0.0000	0.9941	0.9941	3.0000e-005	3.0000e-005	1.0045
Total	9.9000e-004	7.6800e-003	6.8100e-003	6.0000e-005	2.1684	1.0000e-004	2.1685	0.2168	9.0000e-005	0.2169	0.0000	5.8496	5.8496	4.0000e-005	6.9000e-004	6.0586

Mitigated Construction On-Site

	ROG	NOx	CO	SO2	Fugitive PM10	Exhaust PM10	PM10 Total	Fugitive PM2.5	Exhaust PM2.5	PM2.5 Total	Bio- CO2	NBio- CO2	Total CO2	CH4	N2O	CO2e
Category	tons/yr										MT/yr					
Fugitive Dust					0.0000	0.0000	0.0000	0.0000	0.0000	0.0000	0.0000	0.0000	0.0000	0.0000	0.0000	0.0000
Off-Road	0.0140	0.1387	0.1237	3.1000e-004		5.4500e-003	5.4500e-003		5.0100e-003	5.0100e-003	0.0000	27.2477	27.2477	8.8100e-003	0.0000	27.4680
Total	0.0140	0.1387	0.1237	3.1000e-004	0.0000	5.4500e-003	5.4500e-003	0.0000	5.0100e-003	5.0100e-003	0.0000	27.2477	27.2477	8.8100e-003	0.0000	27.4680

Vega SES 4 Solar Energy Storage Project - Imperial County, Annual

EMFAC Off-Model Adjustment Factors for Gasoline Light Duty Vehicle to Account for the SAFE Vehicle Rule Not Applied

3.2 Site Preparation - 2023

Mitigated Construction Off-Site

	ROG	NOx	CO	SO2	Fugitive PM10	Exhaust PM10	PM10 Total	Fugitive PM2.5	Exhaust PM2.5	PM2.5 Total	Bio- CO2	NBio- CO2	Total CO2	CH4	N2O	CO2e
Category	tons/yr										MT/yr					
Hauling	0.0000	0.0000	0.0000	0.0000	0.0000	0.0000	0.0000	0.0000	0.0000	0.0000	0.0000	0.0000	0.0000	0.0000	0.0000	0.0000
Vendor	3.2000e-004	7.2900e-003	2.1800e-003	5.0000e-005	0.1758	9.0000e-005	0.1759	0.0178	8.0000e-005	0.0178	0.0000	4.8556	4.8556	1.0000e-005	6.6000e-004	5.0540
Worker	6.7000e-004	3.9000e-004	4.6300e-003	1.0000e-005	0.0254	1.0000e-005	0.0254	2.7200e-003	1.0000e-005	2.7200e-003	0.0000	0.9941	0.9941	3.0000e-005	3.0000e-005	1.0045
Total	9.9000e-004	7.6800e-003	6.8100e-003	6.0000e-005	0.2012	1.0000e-004	0.2013	0.0205	9.0000e-005	0.0206	0.0000	5.8496	5.8496	4.0000e-005	6.9000e-004	6.0586

3.3 Grading - 2023

Unmitigated Construction On-Site

	ROG	NOx	CO	SO2	Fugitive PM10	Exhaust PM10	PM10 Total	Fugitive PM2.5	Exhaust PM2.5	PM2.5 Total	Bio- CO2	NBio- CO2	Total CO2	CH4	N2O	CO2e
Category	tons/yr										MT/yr					
Fugitive Dust					0.5549	0.0000	0.5549	0.2355	0.0000	0.2355	0.0000	0.0000	0.0000	0.0000	0.0000	0.0000
Off-Road	0.1800	1.8849	1.5022	3.3100e-003		0.0776	0.0776		0.0714	0.0714	0.0000	291.0949	291.0949	0.0942	0.0000	293.4486
Total	0.1800	1.8849	1.5022	3.3100e-003	0.5549	0.0776	0.6325	0.2355	0.0714	0.3068	0.0000	291.0949	291.0949	0.0942	0.0000	293.4486

Vega SES 4 Solar Energy Storage Project - Imperial County, Annual

EMFAC Off-Model Adjustment Factors for Gasoline Light Duty Vehicle to Account for the SAFE Vehicle Rule Not Applied

3.3 Grading - 2023

Unmitigated Construction Off-Site

	ROG	NOx	CO	SO2	Fugitive PM10	Exhaust PM10	PM10 Total	Fugitive PM2.5	Exhaust PM2.5	PM2.5 Total	Bio- CO2	NBio- CO2	Total CO2	CH4	N2O	CO2e
Category	tons/yr										MT/yr					
Hauling	0.0000	0.0000	0.0000	0.0000	0.0000	0.0000	0.0000	0.0000	0.0000	0.0000	0.0000	0.0000	0.0000	0.0000	0.0000	0.0000
Vendor	6.3000e-004	0.0146	4.3700e-003	1.0000e-004	3.8075	1.7000e-004	3.8076	0.3804	1.7000e-004	0.3806	0.0000	9.7112	9.7112	3.0000e-005	1.3300e-003	10.1080
Worker	5.0800e-003	2.9800e-003	0.0352	8.0000e-005	2.0113	5.0000e-005	2.0113	0.2022	4.0000e-005	0.2022	0.0000	7.5548	7.5548	2.5000e-004	2.5000e-004	7.6345
Total	5.7100e-003	0.0176	0.0395	1.8000e-004	5.8188	2.2000e-004	5.8190	0.5826	2.1000e-004	0.5828	0.0000	17.2659	17.2659	2.8000e-004	1.5800e-003	17.7426

Mitigated Construction On-Site

	ROG	NOx	CO	SO2	Fugitive PM10	Exhaust PM10	PM10 Total	Fugitive PM2.5	Exhaust PM2.5	PM2.5 Total	Bio- CO2	NBio- CO2	Total CO2	CH4	N2O	CO2e
Category	tons/yr										MT/yr					
Fugitive Dust					0.2164	0.0000	0.2164	0.0918	0.0000	0.0918	0.0000	0.0000	0.0000	0.0000	0.0000	0.0000
Off-Road	0.1800	1.8849	1.5022	3.3100e-003		0.0776	0.0776		0.0714	0.0714	0.0000	291.0946	291.0946	0.0942	0.0000	293.4483
Total	0.1800	1.8849	1.5022	3.3100e-003	0.2164	0.0776	0.2940	0.0918	0.0714	0.1632	0.0000	291.0946	291.0946	0.0942	0.0000	293.4483

Vega SES 4 Solar Energy Storage Project - Imperial County, Annual

EMFAC Off-Model Adjustment Factors for Gasoline Light Duty Vehicle to Account for the SAFE Vehicle Rule Not Applied

3.3 Grading - 2023

Mitigated Construction Off-Site

	ROG	NOx	CO	SO2	Fugitive PM10	Exhaust PM10	PM10 Total	Fugitive PM2.5	Exhaust PM2.5	PM2.5 Total	Bio- CO2	NBio- CO2	Total CO2	CH4	N2O	CO2e
Category	tons/yr										MT/yr					
Hauling	0.0000	0.0000	0.0000	0.0000	0.0000	0.0000	0.0000	0.0000	0.0000	0.0000	0.0000	0.0000	0.0000	0.0000	0.0000	0.0000
Vendor	6.3000e-004	0.0146	4.3700e-003	1.0000e-004	0.3516	1.7000e-004	0.3518	0.0355	1.7000e-004	0.0357	0.0000	9.7112	9.7112	3.0000e-005	1.3300e-003	10.1080
Worker	5.0800e-003	2.9800e-003	0.0352	8.0000e-005	0.1927	5.0000e-005	0.1927	0.0207	4.0000e-005	0.0207	0.0000	7.5548	7.5548	2.5000e-004	2.5000e-004	7.6345
Total	5.7100e-003	0.0176	0.0395	1.8000e-004	0.5443	2.2000e-004	0.5445	0.0562	2.1000e-004	0.0564	0.0000	17.2659	17.2659	2.8000e-004	1.5800e-003	17.7426

3.4 Building Construction - 2023

Unmitigated Construction On-Site

	ROG	NOx	CO	SO2	Fugitive PM10	Exhaust PM10	PM10 Total	Fugitive PM2.5	Exhaust PM2.5	PM2.5 Total	Bio- CO2	NBio- CO2	Total CO2	CH4	N2O	CO2e
Category	tons/yr										MT/yr					
Off-Road	0.2021	2.0582	2.4807	3.8600e-003		0.1022	0.1022		0.0942	0.0942	0.0000	336.3250	336.3250	0.1069	0.0000	338.9973
Total	0.2021	2.0582	2.4807	3.8600e-003		0.1022	0.1022		0.0942	0.0942	0.0000	336.3250	336.3250	0.1069	0.0000	338.9973

Vega SES 4 Solar Energy Storage Project - Imperial County, Annual

EMFAC Off-Model Adjustment Factors for Gasoline Light Duty Vehicle to Account for the SAFE Vehicle Rule Not Applied

3.4 Building Construction - 2023

Unmitigated Construction Off-Site

	ROG	NOx	CO	SO2	Fugitive PM10	Exhaust PM10	PM10 Total	Fugitive PM2.5	Exhaust PM2.5	PM2.5 Total	Bio- CO2	NBio- CO2	Total CO2	CH4	N2O	CO2e
Category	tons/yr										MT/yr					
Hauling	0.0000	0.0000	0.0000	0.0000	0.0000	0.0000	0.0000	0.0000	0.0000	0.0000	0.0000	0.0000	0.0000	0.0000	0.0000	0.0000
Vendor	1.3200e-003	0.0303	9.0700e-003	2.1000e-004	7.9034	3.6000e-004	7.9037	0.7897	3.4000e-004	0.7900	0.0000	20.1580	20.1580	6.0000e-005	2.7600e-003	20.9818
Worker	0.1387	0.0813	0.9602	2.2500e-003	54.9337	1.3200e-003	54.9350	5.5217	1.2100e-003	5.5229	0.0000	206.3403	206.3403	6.9400e-003	6.7300e-003	208.5188
Total	0.1400	0.1116	0.9692	2.4600e-003	62.8371	1.6800e-003	62.8388	6.3114	1.5500e-003	6.3129	0.0000	226.4983	226.4983	7.0000e-003	9.4900e-003	229.5007

Mitigated Construction On-Site

	ROG	NOx	CO	SO2	Fugitive PM10	Exhaust PM10	PM10 Total	Fugitive PM2.5	Exhaust PM2.5	PM2.5 Total	Bio- CO2	NBio- CO2	Total CO2	CH4	N2O	CO2e
Category	tons/yr										MT/yr					
Off-Road	0.2021	2.0582	2.4807	3.8600e-003		0.1022	0.1022		0.0942	0.0942	0.0000	336.3246	336.3246	0.1069	0.0000	338.9969
Total	0.2021	2.0582	2.4807	3.8600e-003		0.1022	0.1022		0.0942	0.0942	0.0000	336.3246	336.3246	0.1069	0.0000	338.9969

Vega SES 4 Solar Energy Storage Project - Imperial County, Annual

EMFAC Off-Model Adjustment Factors for Gasoline Light Duty Vehicle to Account for the SAFE Vehicle Rule Not Applied

3.4 Building Construction - 2023

Mitigated Construction Off-Site

	ROG	NOx	CO	SO2	Fugitive PM10	Exhaust PM10	PM10 Total	Fugitive PM2.5	Exhaust PM2.5	PM2.5 Total	Bio- CO2	NBio- CO2	Total CO2	CH4	N2O	CO2e
Category	tons/yr										MT/yr					
Hauling	0.0000	0.0000	0.0000	0.0000	0.0000	0.0000	0.0000	0.0000	0.0000	0.0000	0.0000	0.0000	0.0000	0.0000	0.0000	0.0000
Vendor	1.3200e-003	0.0303	9.0700e-003	2.1000e-004	0.7299	3.6000e-004	0.7303	0.0737	3.4000e-004	0.0741	0.0000	20.1580	20.1580	6.0000e-005	2.7600e-003	20.9818
Worker	0.1387	0.0813	0.9602	2.2500e-003	5.2617	1.3200e-003	5.2630	0.5644	1.2100e-003	0.5656	0.0000	206.3403	206.3403	6.9400e-003	6.7300e-003	208.5188
Total	0.1400	0.1116	0.9692	2.4600e-003	5.9916	1.6800e-003	5.9933	0.6381	1.5500e-003	0.6397	0.0000	226.4983	226.4983	7.0000e-003	9.4900e-003	229.5007

3.4 Building Construction - 2024

Unmitigated Construction On-Site

	ROG	NOx	CO	SO2	Fugitive PM10	Exhaust PM10	PM10 Total	Fugitive PM2.5	Exhaust PM2.5	PM2.5 Total	Bio- CO2	NBio- CO2	Total CO2	CH4	N2O	CO2e
Category	tons/yr										MT/yr					
Off-Road	0.2119	2.1309	2.6981	4.2000e-003		0.1033	0.1033		0.0952	0.0952	0.0000	365.8059	365.8059	0.1163	0.0000	368.7125
Total	0.2119	2.1309	2.6981	4.2000e-003		0.1033	0.1033		0.0952	0.0952	0.0000	365.8059	365.8059	0.1163	0.0000	368.7125

Vega SES 4 Solar Energy Storage Project - Imperial County, Annual

EMFAC Off-Model Adjustment Factors for Gasoline Light Duty Vehicle to Account for the SAFE Vehicle Rule Not Applied

3.4 Building Construction - 2024

Unmitigated Construction Off-Site

	ROG	NOx	CO	SO2	Fugitive PM10	Exhaust PM10	PM10 Total	Fugitive PM2.5	Exhaust PM2.5	PM2.5 Total	Bio- CO2	NBio- CO2	Total CO2	CH4	N2O	CO2e
Category	tons/yr										MT/yr					
Hauling	0.0000	0.0000	0.0000	0.0000	0.0000	0.0000	0.0000	0.0000	0.0000	0.0000	0.0000	0.0000	0.0000	0.0000	0.0000	0.0000
Vendor	1.3600e-003	0.0328	9.2200e-003	2.3000e-004	8.5956	3.9000e-004	8.5960	0.8588	3.7000e-004	0.8592	0.0000	21.6265	21.6265	6.0000e-005	2.9400e-003	22.5053
Worker	0.1402	0.0784	0.9637	2.3700e-003	59.7454	1.3600e-003	59.7468	6.0054	1.2500e-003	6.0066	0.0000	217.7043	217.7043	6.8200e-003	6.7600e-003	219.8890
Total	0.1415	0.1112	0.9729	2.6000e-003	68.3411	1.7500e-003	68.3428	6.8642	1.6200e-003	6.8658	0.0000	239.3308	239.3308	6.8800e-003	9.7000e-003	242.3943

Mitigated Construction On-Site

	ROG	NOx	CO	SO2	Fugitive PM10	Exhaust PM10	PM10 Total	Fugitive PM2.5	Exhaust PM2.5	PM2.5 Total	Bio- CO2	NBio- CO2	Total CO2	CH4	N2O	CO2e
Category	tons/yr										MT/yr					
Off-Road	0.2119	2.1309	2.6981	4.2000e-003		0.1033	0.1033		0.0952	0.0952	0.0000	365.8055	365.8055	0.1163	0.0000	368.7120
Total	0.2119	2.1309	2.6981	4.2000e-003		0.1033	0.1033		0.0952	0.0952	0.0000	365.8055	365.8055	0.1163	0.0000	368.7120

Vega SES 4 Solar Energy Storage Project - Imperial County, Annual

EMFAC Off-Model Adjustment Factors for Gasoline Light Duty Vehicle to Account for the SAFE Vehicle Rule Not Applied

3.4 Building Construction - 2024

Mitigated Construction Off-Site

	ROG	NOx	CO	SO2	Fugitive PM10	Exhaust PM10	PM10 Total	Fugitive PM2.5	Exhaust PM2.5	PM2.5 Total	Bio- CO2	NBio- CO2	Total CO2	CH4	N2O	CO2e
Category	tons/yr										MT/yr					
Hauling	0.0000	0.0000	0.0000	0.0000	0.0000	0.0000	0.0000	0.0000	0.0000	0.0000	0.0000	0.0000	0.0000	0.0000	0.0000	0.0000
Vendor	1.3600e-003	0.0328	9.2200e-003	2.3000e-004	0.7938	3.9000e-004	0.7942	0.0802	3.7000e-004	0.0806	0.0000	21.6265	21.6265	6.0000e-005	2.9400e-003	22.5053
Worker	0.1402	0.0784	0.9637	2.3700e-003	5.7226	1.3600e-003	5.7239	0.6138	1.2500e-003	0.6151	0.0000	217.7043	217.7043	6.8200e-003	6.7600e-003	219.8890
Total	0.1415	0.1112	0.9729	2.6000e-003	6.5164	1.7500e-003	6.5181	0.6940	1.6200e-003	0.6957	0.0000	239.3308	239.3308	6.8800e-003	9.7000e-003	242.3943

4.0 Operational Detail - Mobile

4.1 Mitigation Measures Mobile

Vega SES 4 Solar Energy Storage Project - Imperial County, Annual

EMFAC Off-Model Adjustment Factors for Gasoline Light Duty Vehicle to Account for the SAFE Vehicle Rule Not Applied

	ROG	NOx	CO	SO2	Fugitive PM10	Exhaust PM10	PM10 Total	Fugitive PM2.5	Exhaust PM2.5	PM2.5 Total	Bio- CO2	NBio- CO2	Total CO2	CH4	N2O	CO2e
Category	tons/yr										MT/yr					
Mitigated	3.0600e-003	4.9800e-003	0.0337	8.0000e-005	0.6299	6.0000e-005	0.6300	0.0640	5.0000e-005	0.0640	0.0000	7.0965	7.0965	3.0000e-004	3.3000e-004	7.2024
Unmitigated	3.0600e-003	4.9800e-003	0.0337	8.0000e-005	0.6299	6.0000e-005	0.6300	0.0640	5.0000e-005	0.0640	0.0000	7.0965	7.0965	3.0000e-004	3.3000e-004	7.2024

4.2 Trip Summary Information

Land Use	Average Daily Trip Rate			Unmitigated	Mitigated
	Weekday	Saturday	Sunday	Annual VMT	Annual VMT
Refrigerated Warehouse-No Rail	2.96	0.00	0.00	10,455	10,455
Refrigerated Warehouse-No Rail	2.96	0.00	0.00	10,455	10,455
Other Non-Asphalt Surfaces	0.00	0.00	0.00		
Other Non-Asphalt Surfaces	0.00	0.00	0.00		
Total	5.92	0.00	0.00	20,910	20,910

4.3 Trip Type Information

Land Use	Miles			Trip %			Trip Purpose %		
	H-W or C-W	H-S or C-C	H-O or C-NW	H-W or C-W	H-S or C-C	H-O or C-NW	Primary	Diverted	Pass-by
Refrigerated Warehouse-No	16.40	9.50	11.90	59.00	0.00	41.00	92	5	3
Refrigerated Warehouse-No	16.40	9.50	11.90	59.00	0.00	41.00	92	5	3
Other Non-Asphalt Surfaces	16.40	9.50	11.90	0.00	0.00	0.00	0	0	0
Other Non-Asphalt Surfaces	16.40	9.50	11.90	0.00	0.00	0.00	0	0	0

4.4 Fleet Mix

Vega SES 4 Solar Energy Storage Project - Imperial County, Annual

EMFAC Off-Model Adjustment Factors for Gasoline Light Duty Vehicle to Account for the SAFE Vehicle Rule Not Applied

Land Use	LDA	LDT1	LDT2	MDV	LHD1	LHD2	MHD	HHD	OBUS	UBUS	MCY	SBUS	MH
Refrigerated Warehouse-No Rail	0.521846	0.059402	0.180067	0.151114	0.027614	0.006908	0.008276	0.016396	0.000918	0.000121	0.022925	0.000779	0.003633
Other Non-Asphalt Surfaces	0.521846	0.059402	0.180067	0.151114	0.027614	0.006908	0.008276	0.016396	0.000918	0.000121	0.022925	0.000779	0.003633

5.0 Energy Detail

Historical Energy Use: N

5.1 Mitigation Measures Energy

Percent of Electricity Use Generated with Renewable Energy

Category	ROG	NOx	CO	SO2	Fugitive PM10	Exhaust PM10	PM10 Total	Fugitive PM2.5	Exhaust PM2.5	PM2.5 Total	Bio- CO2	NBio- CO2	Total CO2	CH4	N2O	CO2e
Category	tons/yr										MT/yr					
Electricity Mitigated						0.0000	0.0000		0.0000	0.0000	0.0000	0.0000	0.0000	0.0000	0.0000	0.0000
Electricity Unmitigated						0.0000	0.0000		0.0000	0.0000	0.0000	598.1923	598.1923	0.1039	0.0126	604.5433
NaturalGas Mitigated	0.0486	0.4418	0.3711	2.6500e-003		0.0336	0.0336		0.0336	0.0336	0.0000	480.9912	480.9912	9.2200e-003	8.8200e-003	483.8495
NaturalGas Unmitigated	0.0486	0.4418	0.3711	2.6500e-003		0.0336	0.0336		0.0336	0.0336	0.0000	480.9912	480.9912	9.2200e-003	8.8200e-003	483.8495

Vega SES 4 Solar Energy Storage Project - Imperial County, Annual

EMFAC Off-Model Adjustment Factors for Gasoline Light Duty Vehicle to Account for the SAFE Vehicle Rule Not Applied

5.2 Energy by Land Use - Natural Gas

Unmitigated

	Natural Gas Use	ROG	NOx	CO	SO2	Fugitive PM10	Exhaust PM10	PM10 Total	Fugitive PM2.5	Exhaust PM2.5	PM2.5 Total	Bio- CO2	NBio- CO2	Total CO2	CH4	N2O	CO2e
Land Use	kBTU/yr	tons/yr										MT/yr					
Other Non-Asphalt Surfaces	0	0.0000	0.0000	0.0000	0.0000		0.0000	0.0000		0.0000	0.0000	0.0000	0.0000	0.0000	0.0000	0.0000	0.0000
Refrigerated Warehouse-No Rail	4.50672e+006	0.0486	0.4418	0.3711	2.6500e-003		0.0336	0.0336		0.0336	0.0336	0.0000	480.9912	480.9912	9.2200e-003	8.8200e-003	483.8495
Total		0.0486	0.4418	0.3711	2.6500e-003		0.0336	0.0336		0.0336	0.0336	0.0000	480.9912	480.9912	9.2200e-003	8.8200e-003	483.8495

Mitigated

	Natural Gas Use	ROG	NOx	CO	SO2	Fugitive PM10	Exhaust PM10	PM10 Total	Fugitive PM2.5	Exhaust PM2.5	PM2.5 Total	Bio- CO2	NBio- CO2	Total CO2	CH4	N2O	CO2e
Land Use	kBTU/yr	tons/yr										MT/yr					
Other Non-Asphalt Surfaces	0	0.0000	0.0000	0.0000	0.0000		0.0000	0.0000		0.0000	0.0000	0.0000	0.0000	0.0000	0.0000	0.0000	0.0000
Refrigerated Warehouse-No Rail	4.50672e+006	0.0486	0.4418	0.3711	2.6500e-003		0.0336	0.0336		0.0336	0.0336	0.0000	480.9912	480.9912	9.2200e-003	8.8200e-003	483.8495
Total		0.0486	0.4418	0.3711	2.6500e-003		0.0336	0.0336		0.0336	0.0336	0.0000	480.9912	480.9912	9.2200e-003	8.8200e-003	483.8495

Vega SES 4 Solar Energy Storage Project - Imperial County, Annual

EMFAC Off-Model Adjustment Factors for Gasoline Light Duty Vehicle to Account for the SAFE Vehicle Rule Not Applied

5.3 Energy by Land Use - Electricity

Unmitigated

	Electricity Use	Total CO2	CH4	N2O	CO2e
Land Use	kWh/yr	MT/yr			
Other Non-Asphalt Surfaces	0	0.0000	0.0000	0.0000	0.0000
Refrigerated Warehouse-No Rail	3.47086e+006	598.1923	0.1039	0.0126	604.5433
Total		598.1923	0.1039	0.0126	604.5433

Mitigated

	Electricity Use	Total CO2	CH4	N2O	CO2e
Land Use	kWh/yr	MT/yr			
Other Non-Asphalt Surfaces	0	0.0000	0.0000	0.0000	0.0000
Refrigerated Warehouse-No Rail	0	0.0000	0.0000	0.0000	0.0000
Total		0.0000	0.0000	0.0000	0.0000

6.0 Area Detail

Vega SES 4 Solar Energy Storage Project - Imperial County, Annual

EMFAC Off-Model Adjustment Factors for Gasoline Light Duty Vehicle to Account for the SAFE Vehicle Rule Not Applied

6.1 Mitigation Measures Area

	ROG	NOx	CO	SO2	Fugitive PM10	Exhaust PM10	PM10 Total	Fugitive PM2.5	Exhaust PM2.5	PM2.5 Total	Bio- CO2	NBio- CO2	Total CO2	CH4	N2O	CO2e
Category	tons/yr										MT/yr					
Mitigated	2.4800	5.0000e-005	5.7400e-003	0.0000		2.0000e-005	2.0000e-005		2.0000e-005	2.0000e-005	0.0000	0.0112	0.0112	3.0000e-005	0.0000	0.0119
Unmitigated	2.4800	5.0000e-005	5.7400e-003	0.0000		2.0000e-005	2.0000e-005		2.0000e-005	2.0000e-005	0.0000	0.0112	0.0112	3.0000e-005	0.0000	0.0119

6.2 Area by SubCategory

Unmitigated

	ROG	NOx	CO	SO2	Fugitive PM10	Exhaust PM10	PM10 Total	Fugitive PM2.5	Exhaust PM2.5	PM2.5 Total	Bio- CO2	NBio- CO2	Total CO2	CH4	N2O	CO2e
SubCategory	tons/yr										MT/yr					
Architectural Coating	0.5304					0.0000	0.0000		0.0000	0.0000	0.0000	0.0000	0.0000	0.0000	0.0000	0.0000
Consumer Products	1.9490					0.0000	0.0000		0.0000	0.0000	0.0000	0.0000	0.0000	0.0000	0.0000	0.0000
Landscaping	5.3000e-004	5.0000e-005	5.7400e-003	0.0000		2.0000e-005	2.0000e-005		2.0000e-005	2.0000e-005	0.0000	0.0112	0.0112	3.0000e-005	0.0000	0.0119
Total	2.4800	5.0000e-005	5.7400e-003	0.0000		2.0000e-005	2.0000e-005		2.0000e-005	2.0000e-005	0.0000	0.0112	0.0112	3.0000e-005	0.0000	0.0119

Vega SES 4 Solar Energy Storage Project - Imperial County, Annual

EMFAC Off-Model Adjustment Factors for Gasoline Light Duty Vehicle to Account for the SAFE Vehicle Rule Not Applied

6.2 Area by SubCategory

Mitigated

	ROG	NOx	CO	SO2	Fugitive PM10	Exhaust PM10	PM10 Total	Fugitive PM2.5	Exhaust PM2.5	PM2.5 Total	Bio- CO2	NBio- CO2	Total CO2	CH4	N2O	CO2e
SubCategory	tons/yr										MT/yr					
Architectural Coating	0.5304					0.0000	0.0000		0.0000	0.0000	0.0000	0.0000	0.0000	0.0000	0.0000	0.0000
Consumer Products	1.9490					0.0000	0.0000		0.0000	0.0000	0.0000	0.0000	0.0000	0.0000	0.0000	0.0000
Landscaping	5.3000e-004	5.0000e-005	5.7400e-003	0.0000		2.0000e-005	2.0000e-005		2.0000e-005	2.0000e-005	0.0000	0.0112	0.0112	3.0000e-005	0.0000	0.0119
Total	2.4800	5.0000e-005	5.7400e-003	0.0000		2.0000e-005	2.0000e-005		2.0000e-005	2.0000e-005	0.0000	0.0112	0.0112	3.0000e-005	0.0000	0.0119

7.0 Water Detail

7.1 Mitigation Measures Water

Vega SES 4 Solar Energy Storage Project - Imperial County, Annual

EMFAC Off-Model Adjustment Factors for Gasoline Light Duty Vehicle to Account for the SAFE Vehicle Rule Not Applied

	Total CO2	CH4	N2O	CO2e
Category	MT/yr			
Mitigated	4.6907	0.1068	2.5800e-003	8.1317
Unmitigated	4.6907	0.1068	2.5800e-003	8.1317

7.2 Water by Land Use

Unmitigated

	Indoor/Outdoor Use	Total CO2	CH4	N2O	CO2e
Land Use	Mgal	MT/yr			
Other Non-Asphalt Surfaces	0 / 0	0.0000	0.0000	0.0000	0.0000
Refrigerated Warehouse-No Rail	3.259 / 0	4.6907	0.1068	2.5800e-003	8.1317
Total		4.6907	0.1068	2.5800e-003	8.1317

Vega SES 4 Solar Energy Storage Project - Imperial County, Annual

EMFAC Off-Model Adjustment Factors for Gasoline Light Duty Vehicle to Account for the SAFE Vehicle Rule Not Applied

7.2 Water by Land Use

Mitigated

	Indoor/Outdoor Use	Total CO2	CH4	N2O	CO2e
Land Use	Mgal	MT/yr			
Other Non-Asphalt Surfaces	0 / 0	0.0000	0.0000	0.0000	0.0000
Refrigerated Warehouse-No Rail	3.259 / 0	4.6907	0.1068	2.5800e-003	8.1317
Total		4.6907	0.1068	2.5800e-003	8.1317

8.0 Waste Detail

8.1 Mitigation Measures Waste

Category/Year

	Total CO2	CH4	N2O	CO2e
	MT/yr			
Mitigated	33.2479	1.9649	0.0000	82.3702
Unmitigated	33.2479	1.9649	0.0000	82.3702

Vega SES 4 Solar Energy Storage Project - Imperial County, Annual

EMFAC Off-Model Adjustment Factors for Gasoline Light Duty Vehicle to Account for the SAFE Vehicle Rule Not Applied

8.2 Waste by Land Use

Unmitigated

	Waste Disposed	Total CO2	CH4	N2O	CO2e
Land Use	tons	MT/yr			
Other Non-Asphalt Surfaces	0	0.0000	0.0000	0.0000	0.0000
Refrigerated Warehouse-No Rail	163.79	33.2479	1.9649	0.0000	82.3702
Total		33.2479	1.9649	0.0000	82.3702

Mitigated

	Waste Disposed	Total CO2	CH4	N2O	CO2e
Land Use	tons	MT/yr			
Other Non-Asphalt Surfaces	0	0.0000	0.0000	0.0000	0.0000
Refrigerated Warehouse-No Rail	163.79	33.2479	1.9649	0.0000	82.3702
Total		33.2479	1.9649	0.0000	82.3702

Vega SES 4 Solar Energy Storage Project - Imperial County, Annual

EMFAC Off-Model Adjustment Factors for Gasoline Light Duty Vehicle to Account for the SAFE Vehicle Rule Not Applied

Equipment Type	Number	Hours/Day	Days/Year	Horse Power	Load Factor	Fuel Type
Other Construction Equipment	3	8.00	8	172	0.42	Diesel
Off-Highway Trucks	1	2.00	8	402	0.38	Diesel

UnMitigated/Mitigated

	ROG	NOx	CO	SO2	Fugitive PM10	Exhaust PM10	PM10 Total	Fugitive PM2.5	Exhaust PM2.5	PM2.5 Total	Bio- CO2	NBio- CO2	Total CO2	CH4	N2O	CO2e
Equipment Type	tons/yr										MT/yr					
Off-Highway Trucks	5.1000e-004	3.5900e-003	3.3000e-003	1.0000e-005		1.3000e-004	1.3000e-004		1.2000e-004	1.2000e-004	0.0000	1.1669	1.1669	3.8000e-004	0.0000	1.1763
Other Construction Equipment	4.1400e-003	0.0408	0.0475	7.0000e-005		2.1200e-003	2.1200e-003		1.9500e-003	1.9500e-003	0.0000	6.4415	6.4415	2.0800e-003	0.0000	6.4936
Total	4.6500e-003	0.0444	0.0508	8.0000e-005		2.2500e-003	2.2500e-003		2.0700e-003	2.0700e-003	0.0000	7.6084	7.6084	2.4600e-003	0.0000	7.6699

10.0 Stationary Equipment

Fire Pumps and Emergency Generators

Equipment Type	Number	Hours/Day	Hours/Year	Horse Power	Load Factor	Fuel Type
----------------	--------	-----------	------------	-------------	-------------	-----------

Boilers

Equipment Type	Number	Heat Input/Day	Heat Input/Year	Boiler Rating	Fuel Type
----------------	--------	----------------	-----------------	---------------	-----------

User Defined Equipment

Equipment Type	Number
----------------	--------

11.0 Vegetation

Vega SES 4 Solar Energy Storage Project - Imperial County, Annual

EMFAC Off-Model Adjustment Factors for Gasoline Light Duty Vehicle to Account for the SAFE Vehicle Rule Not Applied

Biological Technical Report

Vega SES 4 Solar Project

Imperial County, California

Prepared for:

Vega SES 4, LLC
604 Sutter Street
Suite 250
Folsom, California 95630

Submitted by:

ECORP Consulting, Inc.
3838 Camino Del Rio North
Suite 370
San Diego, California 92108
(858) 279-4040

November 2020

Revised July 2022



ECORP Consulting, Inc.
ENVIRONMENTAL CONSULTANTS

PC ORIGINAL PKG

CONTENTS

1.0 INTRODUCTION.....4

 1.1 Purpose of the Report.....4

 1.2 Project Location and Description.....4

2.0 REGULATORY CONSIDERATIONS.....7

 2.1 Federal Regulations.....7

 2.1.1 Endangered Species Act.....7

 2.1.2 Migratory Bird Treaty Act.....7

 2.1.3 Clean Water Act.....8

 2.2 State and Local Regulations.....8

 2.2.1 California Endangered Species Act.....8

 2.2.2 Fully Protected Species.....8

 2.2.3 Native Plant Protection Act.....9

 2.2.4 Porter Cologne Water Quality Control Act.....9

 2.2.5 California Fish and Game Code.....10

 2.2.6 Conservation and Open Space Element.....10

 2.2.7 California Environmental Quality Act Significance Criteria.....10

3.0 METHODS.....11

 3.1 Literature Review.....11

 3.2 Field Survey.....12

 3.2.1 Small Unmanned Aircraft System Survey and Vegetation Mapping.....12

 3.2.2 Biological Reconnaissance Survey.....12

 3.2.3 Aquatic Resources Delineation.....13

 3.3 Potential for Occurrence Determinations.....13

4.0 RESULTS.....14

 4.1 Literature Review.....14

 4.1.1 Special-Status Plants and Wildlife.....14

 4.1.2 U.S. Fish and Wildlife Service Designated Critical Habitat.....14

 4.2 Biological Reconnaissance Survey.....14

 4.2.1 Property Characteristics.....15

 4.2.2 Vegetation Communities/Land Use.....25

 4.2.3 Wildlife Observed.....37

 4.3 Special-Status Species Assessment.....37

 4.3.1 Plants.....37

 4.3.2 Wildlife.....39

4.4 Jurisdictional Aquatic Resources Assessment..... 53

4.5 Wildlife Movement Corridors, Linkages, and Significant Ecological Areas..... 53

5.0 IMPACT ASSESSMENT..... 54

5.1.1 Special-Status Species..... 54

5.1.2 Sensitive Natural Communities..... 56

5.1.3 State- and/or Federally Protected Wetlands and Waters 57

5.1.4 Wildlife Corridors and Nursery Sites..... 57

5.1.5 Habitat and Conservation Plans and Natural Community Conservation..... 57

6.0 RECOMMENDATIONS AND MITIGATION MEASURES..... 57

7.0 CERTIFICATION 60

8.0 REFERENCES..... 61

LIST OF TABLES

Table 1. USGS Quadrangle Information4

Table 2. Weather Conditions During the Survey..... 15

Table 3. Vegetation Communities and Land Covers in Project Area 25

Table 4. CNPS Status Designations 38

Table 5. Wildlife Status Designations 40

LIST OF FIGURES

Figure 1. Project Location and Vicinity5

Figure 2. Site Plan.....6

Figure 3. Natural Resources Conservation Service Soil Types..... 16

Figure 4. Vegetation Communities and Land Cover..... 26

Figure 5. Special-Status Species Observations 42

LIST OF ATTACHMENTS

- Attachment A – Representative Site Photographs
- Attachment B – Special-Status Plant Potential For Occurrence
- Attachment C – Special-Status Wildlife Potential For Occurrence

LIST OF ACRONYMS AND ABBREVIATIONS

AOU	American Ornithologists' Union
CDFW	California Department of Fish and Wildlife
CEQA	California Environmental Quality Act
CFR	Code of Federal Regulations
CNDDDB	California Natural Diversity Data Base
CNPS	California Native Plant Society
CNPSEI	CNPS Electronic Inventory
CWA	Clean Water Act
ESA	Endangered Species Act
GIS	Geographic Information System
GPS	Global Positioning System
HCP	Habitat conservation plan
MBTA	Migratory Bird Treaty Act
MW	Megawatt
MWH	Megawatt-hour
NPPA	Native Plant Protection Act
NRCS	Natural Resources Conservation Service
Project	Vega SES 4 Solar Project
RWQCB	Regional Water Quality Control Board (Colorado River Basin)
SAA	Streambed Alteration Agreement
SSAR	Society for the Study of Amphibians and Reptiles
SSC	Species of Special Concern
sUAS	Small unmanned aircraft system
SWRCB	State Water Resources Control Board
USACE	U.S. Army Corps of Engineers
USEPA	U.S. Environmental Protection Agency
USFWS	U.S. Fish and Wildlife Service
USGS	U.S. Geological Survey

1.0 INTRODUCTION

The Vega SES 4 Solar Project (Project) is a 100-Megawatt (MW) direct current (dc) and 400 MW-hour (MWH) battery storage utility-scale solar project located on approximately ±511.61 acres of vacant land in Imperial County, California (CA). ECORP Consulting, Inc. conducted a literature review, small unmanned aircraft system (sUAS) survey, and biological reconnaissance survey of the Project Area to document the existing biological resources, to assess the habitat for its potential to support sensitive plant and wildlife species, and, as required under the California Environmental Quality Act (CEQA), to determine whether Project-related impacts would occur to sensitive biological resources.

1.1 Purpose of the Report

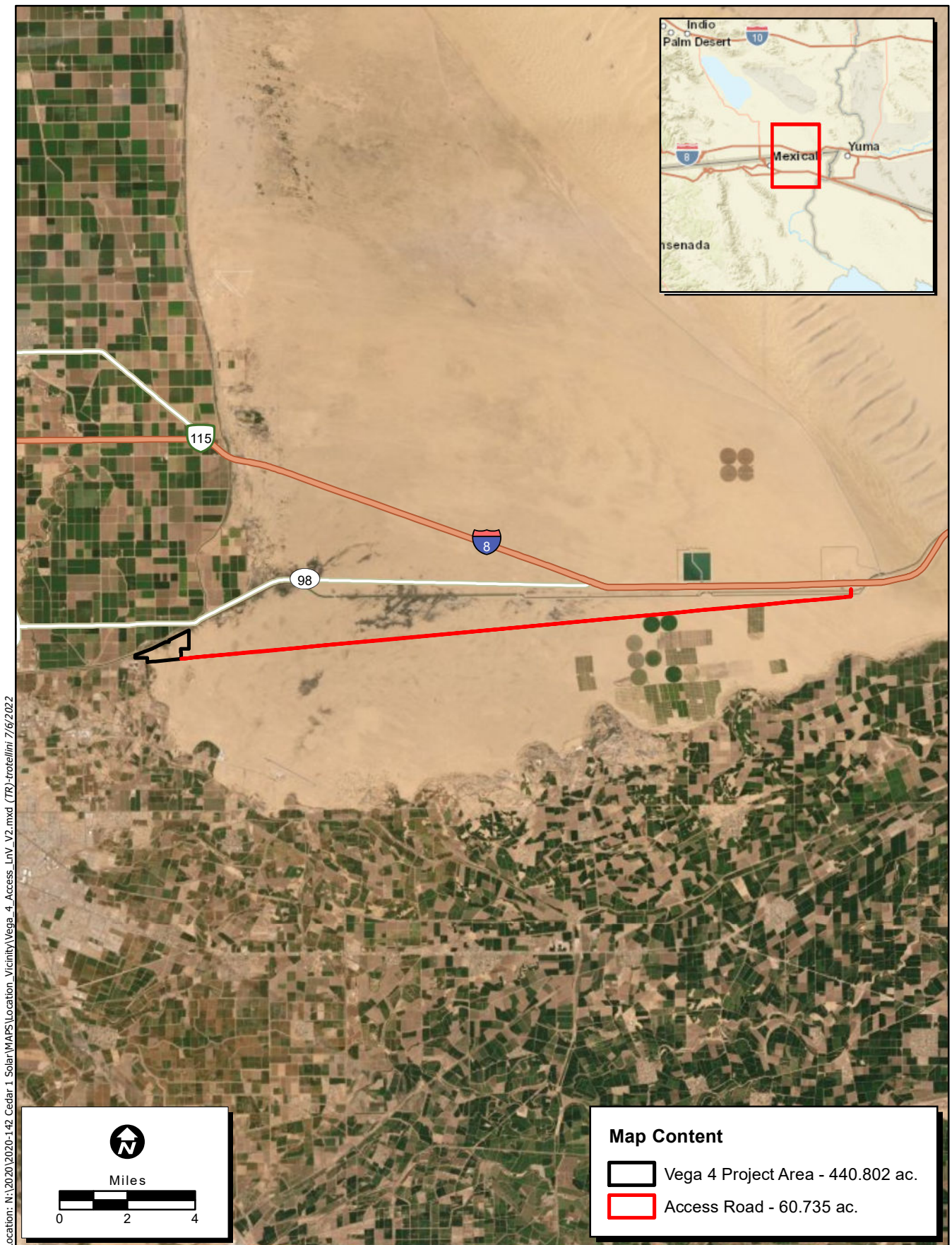
This report was prepared to describe biological resources in the Project and to support Project review under CEQA. Assessment of potential occurrences of special-status plants and animals is based on habitat, geographic and elevational range, and data from field surveys conducted by ECORP in 2020 and 2022. For purposes of this report, the term “Project Area” refers to the solar field and the access road which include areas of permanent impacts. The term “Survey Area” refers to the areas proposed to be directly affected by the Project, the 500-foot buffer, and areas potentially subject to temporary impacts.

1.2 Project Location and Description

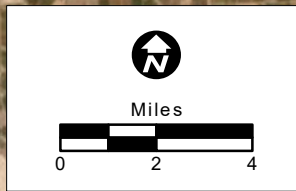
The proposed Project includes a 100-MW dc and 400 MWH battery storage utility-scale solar project located on approximately 511.61 acres of vacant land on two parcels in Imperial County, California (Assessor Parcel Numbers 059-300-015 and 059-300-017). An approximately 22-linear-mile access road totaling 61 acres will be used to access the solar site. The Project Area is approximately nine miles southeast of Calexico, California, and ½ mile south of Highway 98. It is adjacent to the All-American Canal to the north and the United States (U.S.)/Mexico border to the south (Figure 1). A complete summary of geographic information for the Study Area is provided in Table 1.

USGS 7.5-Minute Quad Map Name	Township	Range	Section(s)	Approximate Center of Study Area
Bonds Corner, CA (1976) Midway Well NW, CA (1979) Midway Well, CA (1979) Grays Well, CA (1976)	17S	16E 17E 18E 19E 20E	12, 13, 14 7, 8, 9, 10, 11, 12 1, 7, 8, 9, 10, 11, 12 1, 2, 3, 4, 5, 6 1, 6	32.682898, -115.304246

The Project will connect to an Imperial Irrigation District (IID) 92 kilovolt transmission line that runs close to the property. The Project is also currently contemplated to include a potential cross border permit to enable building a transmission line approximately three miles from the proposed site substation across the international border to deliver power to the closest Federal Electricity Commission substation in Mexico (Figure 2).



Location: N:\2020\2020-142_Cedar 1 Solar\WAPS\Location_Vicinity\Vega_4_Access_LnV_V2.mxd (TR)-trotellini 7/6/2022



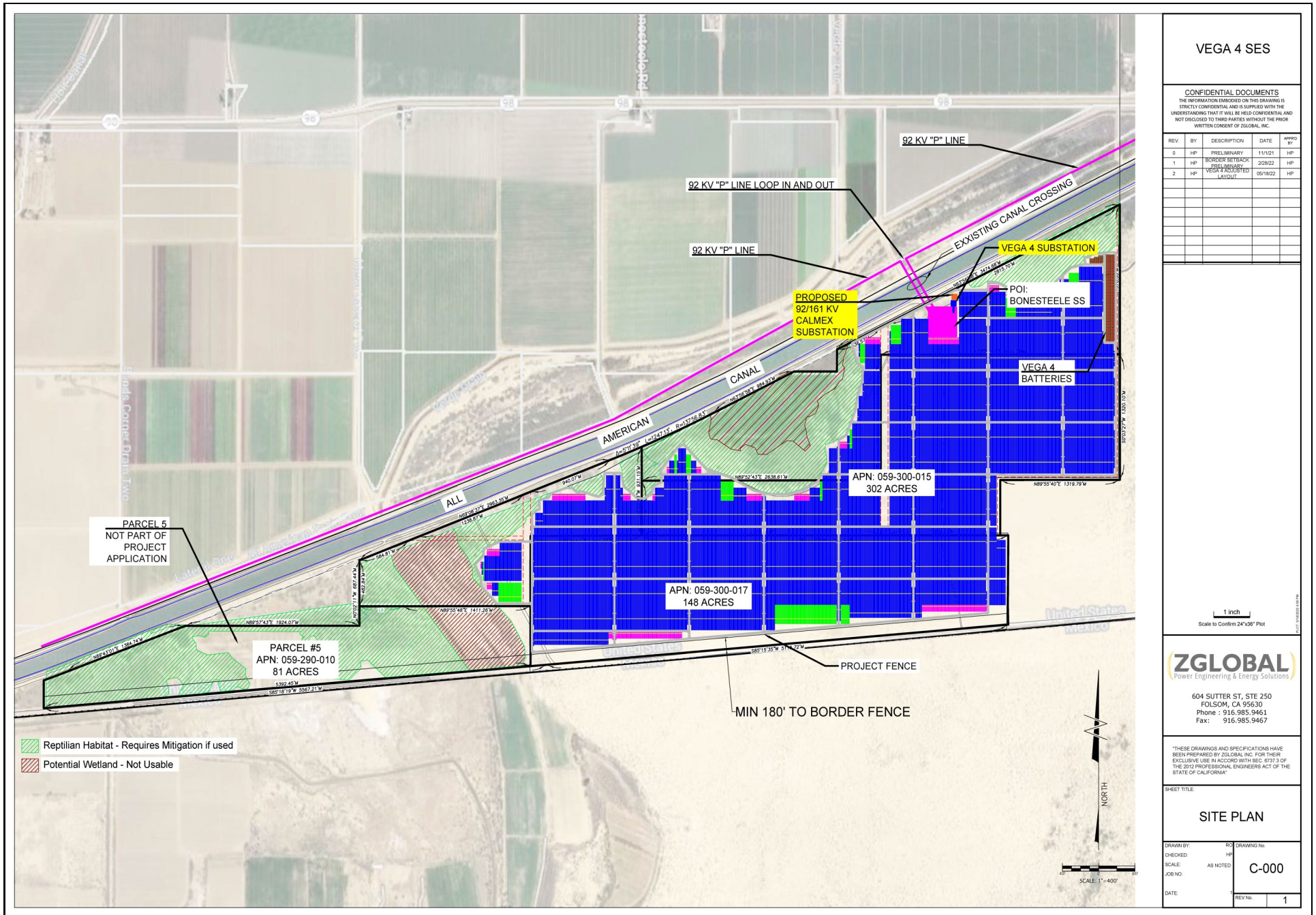
Map Content

- Vega 4 Project Area - 440.802 ac.
- Access Road - 60.735 ac.

Map Date: 6/29/2022
 Service Layer Credits: Sources: Esri, HERE, Garmin, USGS, Intermap, INCREMENT P, NRCan, Esri Japan, METI, Esri China (Hong Kong), Esri Korea, Esri (Thailand), NGCC, (c) OpenStreetMap contributors, and the GIS User Community

Figure 1. Project Location and Vicinity

2020-142 Vega SES 4



VEGA 4 SES

CONFIDENTIAL DOCUMENTS
 THE INFORMATION SHOWN ON THIS DRAWING IS STRICTLY CONFIDENTIAL AND IS SUPPLIED WITH THE UNDERSTANDING THAT IT WILL BE HELD CONFIDENTIAL AND NOT DISCLOSED TO THIRD PARTIES WITHOUT THE PRIOR WRITTEN CONSENT OF ZGLOBAL, INC.

REV.	BY	DESCRIPTION	DATE	APPROV BY
0	HP	PRELIMINARY	11/1/21	HP
1	HP	BORDER SETBACK PRELIMINARY	2/28/22	HP
2	HP	VEGA 4 ADJUSTED LAYOUT	05/18/22	HP

1 inch
Scale to Confirm 24"x36" Plot

ZGLOBAL
Power Engineering & Energy Solutions

604 SUTTER ST, STE 250
FOLSOM, CA 95630
Phone : 916.985.9461
Fax : 916.985.9467

THESE DRAWINGS AND SPECIFICATIONS HAVE BEEN PREPARED BY ZGLOBAL, INC. FOR THEIR EXCLUSIVE USE IN ACCORD WITH SEC. 8737.3 OF THE STATE PROFESSIONAL ENGINEERS ACT OF THE STATE OF CALIFORNIA

SHEET TITLE:

SITE PLAN	
DRAWN BY: HP	REV. NO: 1
CHECKED: AS NOTED	DRAWING NO: C-000
JOB NO:	SCALE: AS NOTED
DATE:	SCALE: 1" = 400'

Topography is relatively flat with elevations ranging between 11 meters (38 feet) and 48 meters (159 feet) above mean sea level. Adjacent land uses include agricultural and ranch land to the north and west, the U.S./Mexico border to the south, and undeveloped land to the east. The All-American Canal travels northeast to southwest, north of the site. The access road runs east-west directly north and adjacent to the U.S./Mexico border wall.

2.0 REGULATORY CONSIDERATIONS

The biological reconnaissance survey was conducted to identify potential constraints and to ensure compliance with State and federal regulations regarding listed, protected, and sensitive species. The regulations are detailed below.

2.1 Federal Regulations

2.1.1 Endangered Species Act

The Endangered Species Act (ESA) protects plants and animals that are listed as endangered or threatened by the U.S. Fish and Wildlife Service (USFWS) and the National Marine Fisheries Service. Section 9 of the ESA prohibits the taking of endangered wildlife, where taking is defined as “harass, harm, pursue, hunt, shoot, wound, kill, trap, capture, collect, or attempt to engage in such conduct” (50 Code of Federal Regulations [CFR] 17.3). For plants, this statute governs removing, possessing, maliciously damaging, or destroying any endangered plant on federal land and removing, cutting, digging up, damaging, or destroying any endangered plant on non-federal land in knowing violation of state law (16 U.S. Code 1538). Under Section 7 of the ESA, federal agencies are required to consult with the USFWS if their actions, including permit approvals or funding, could adversely affect a listed (or proposed) species (including plants) or its critical habitat. Through consultation and the issuance of a biological opinion, the USFWS may issue an incidental take statement allowing take of the species that is incidental to an otherwise authorized activity provided the activity will not jeopardize the continued existence of the species. Section 10 of the ESA provides for issuance of incidental take permits where no other federal actions are necessary provided a habitat conservation plan (HCP) is developed.

2.1.2 Migratory Bird Treaty Act

The Migratory Bird Treaty Act (MBTA) implements international treaties between the U.S. and other nations devised to protect migratory birds, any of their parts, eggs, and nests from activities such as hunting, pursuing, capturing, killing, selling, and shipping, unless expressly authorized in the regulations or by permit. As authorized by the MBTA, the USFWS issues permits to qualified applicants for the following types of activities: falconry, raptor propagation, scientific collecting, special purposes (rehabilitation, education, migratory game bird propagation, and salvage), take of depredating birds, taxidermy, and waterfowl sale and disposal. The regulations governing migratory bird permits can be found in 50 CFR Part 13 General Permit Procedures and 50 CFR Part 21 Migratory Bird Permits. The State of California has incorporated the protection of birds of prey in Sections 3800, 3513, and 3503.5 of the California Fish and Game Code.

2.1.3 Clean Water Act

The purpose of the Clean Water Act (CWA) is to “restore and maintain the chemical, physical, and biological integrity of the nation’s waters.” Section 404 of the CWA prohibits the discharge of dredged or fill material into Waters of the U.S. without a permit from the U.S. Army Corps of Engineers (USACE). The definition of Waters of the U.S. includes rivers, streams, estuaries, the territorial seas, ponds, lakes, and wetlands. Wetlands are defined as those areas “that are inundated or saturated by surface or ground water at a frequency and duration sufficient to support, and that under normal circumstances do support, a prevalence of vegetation typically adapted for life in saturated soil conditions” (33 CFR 328.3 7b). The U.S. Environmental Protection Agency (USEPA) acts as a cooperating agency to set policy, guidance, and criteria for use in evaluation permit applications and also reviews USACE permit applications.

The USACE regulates “fill” or dredging of fill material within its jurisdictional features. “Fill material” means any material used for the primary purpose of replacing an aquatic area with dry land or changing the bottom elevation of a water body. Substantial impacts to wetlands may require an individual permit. Projects that only minimally affect wetlands may meet the conditions of one of the existing Nationwide Permits. A Water Quality Certification or waiver pursuant to Section 401 of the CWA is required for Section 404 permit actions; this certification or waiver is issued by the State Water Resources Control Board (SWRCB), administered by each of nine California Regional Water Quality Control Boards.

2.2 State and Local Regulations

2.2.1 California Endangered Species Act

The California ESA generally parallels the main provisions of the ESA but, unlike its federal counterpart, the California ESA applies the take prohibitions to species proposed for listing (called “candidates” by the State). Section 2080 of the California Fish and Game Code prohibits the taking, possession, purchase, sale, and import or export of endangered, threatened, or candidate species, unless otherwise authorized by permit or in the regulations. Take is defined in Section 86 of the California Fish and Game Code as “hunt, pursue, catch, capture, or kill, or attempt to hunt, pursue, catch, capture, or kill.” The California ESA allows for take incidental to otherwise lawful development projects. State lead agencies are required to consult with California Department of Fish and Wildlife (CDFW) to ensure that any action they undertake is not likely to jeopardize the continued existence of any endangered or threatened species or result in destruction or adverse modification of essential habitat.

2.2.2 Fully Protected Species

The State of California first began to designate species as “fully protected” prior to the creation of the federal and California ESAs. Lists of fully protected species were initially developed to provide protection to those animals that were rare or faced possible extinction, and included fish, amphibians and reptiles, birds, and mammals. Most fully protected species have since been listed as threatened or endangered under federal and/or California ESAs. The regulations that implement the Fully Protected Species Statute (California Fish and Game Code § 4700) provide that fully protected species may not be taken or

possessed at any time. Furthermore, CDFW prohibits any State agency from issuing incidental take permits for fully protected species, except for necessary scientific research.

2.2.3 Native Plant Protection Act

The Native Plant Protection Act (NPPA) of 1977 (California Fish and Game Code §§ 1900-1913) was created with the intent to “preserve, protect and enhance rare and endangered plants in this State.” The NPPA is administered by CDFW. The Fish and Wildlife Commission has the authority to designate native plants as “endangered” or “rare” and to protect endangered and rare plants from take. The California ESA of 1984 (California Fish and Game Code § 2050-2116) provided further protection for rare and endangered plant species, but the NPPA remains part of the California Fish and Game Code.

2.2.4 Porter Cologne Water Quality Control Act

The RWQCB implements water quality regulations under the federal CWA and the Porter-Cologne Water Quality Act. These regulations require compliance with the National Pollutant Discharge Elimination System (NPDES), including compliance with the California Storm Water NPDES General Construction Permit for discharges of storm water runoff associated with construction activities. General Construction Permits for projects that disturb one or more acres of land require development and implementation of a Storm Water Pollution Prevention Plan. Under the Porter-Cologne Water Quality Act, the RWQCB regulates actions that would involve “discharging waste, or proposing to discharge waste, with any region that could affect the water of the state” [Water Code 13260(a)].

Waters of the State are defined as “any surface water or groundwater, including saline waters, within the boundaries of the state” (Water Code 13050[e]). The RWQCB regulates all such activities, as well as dredging, filling, or discharging materials into Waters of the State that are not regulated by the USACE due to a lack of connectivity with a navigable water body. The RWQCB may require issuance of Waste Discharge Requirements for these activities.

On April 2, 2019, the SWRCB adopted the *State Wetland Definition and Procedures for Discharges of Dredged or Fill Material to Waters of the State* (referred to as the Procedures) for inclusion in the *Water Quality Control Plan for Inland Surface Waters, Enclosed Bays, and Estuaries of California* (Resolution No. 2019-0015). The new Procedures include:

- definition of wetlands and aquatic resources that are Waters of the State,
- description of application requirements for individual orders (not general orders) for water quality certification, or waste discharge requirements,
- description of information required in compensatory mitigation plans, and
- definition of exemptions to application procedures.

The Office of Administrative Law approved the procedures on August 28, 2019, and the rule went into effect May 28, 2020.

2.2.5 California Fish and Game Code

Streambed Alteration Agreement

Section 1602 of the California Fish and Game Code requires that a Notification of Lake or Streambed Alteration be submitted to CDFW for “any activity that may substantially divert or obstruct the natural flow or substantially change the bed, channel, or bank of any river, stream, or lake.” The CDFW reviews the proposed actions and, if necessary, submits to the Applicant a proposal for measures to protect affected fish and wildlife resources. The final proposal that is mutually agreed upon by CDFW and the Applicant is the Streambed Alteration Agreement (SAA). Often, projects that require an SAA also require a permit from the USACE under Section 404 of the CWA. In these instances, the conditions of the Section 404 permit and the SAA may overlap.

Migratory Birds

The CDFW enforces the protection of nongame native birds in §§ 3503, 3503.5, and 3800 of the California Fish and Game Code. Section 3513 of the California Fish and Game Code prohibits the possession or take of birds listed under the MBTA. These sections mandate the protection of California nongame native birds’ nests and also make it unlawful to take these birds. All raptor species are protected from “take” pursuant to California Fish and Game Code § 3503.5 and are also protected at the federal level by the MBTA of 1918 (USFWS 1918).

2.2.6 Conservation and Open Space Element

Imperial County created the Conservation and Open Space Element plan to provide details and measures for management and preservation of biological resources as well as various other resources (i.e. cultural, soils, minerals, etc.). This plan focuses on protecting scarce resources and preventing wasteful exploitation, neglect, and destruction of California’s natural resources. The plan outlines areas with sensitive habitat and sensitive species, also labelled “Resource Areas”. Open space easements and protection of riparian habitat, rock outcrops, California fan palm oases, and wildlife corridors are also discussed in the plan. As it currently stands, the open space element follows CEQA guidelines with special focus on its scarce resources.

2.2.7 California Environmental Quality Act Significance Criteria

Section 15064.7 of the CEQA Guidelines encourages local agencies to develop and publish the thresholds the agency uses in determining the significance of environmental effects caused by projects under its review. However, agencies may also rely upon the guidance provided by the expanded Initial Study checklist contained in Appendix G of the CEQA Guidelines. Appendix G provides examples of impacts that would normally be considered significant. Based on these examples, impacts to biological resources would normally be considered significant if the project would:

- have a substantial adverse effect, either directly or through habitat modifications, on any species identified as a candidate, sensitive, or special status species in local or regional plans, policies, or regulations, or by CDFW or USFWS;

- have a substantial adverse effect on any riparian habitat or other sensitive natural community identified in local or regional plans, policies, regulations or by CDFW or USFWS;
- have a substantial adverse effect on State or federally protected wetlands (including, but not limited to, marsh, vernal pool, and coastal) through direct removal, filling, hydrological interruption, or other means;
- interfere substantially with the movement of any native resident or migratory fish or wildlife species, or with established native resident or migratory wildlife corridors, or impede the use of native wildlife nursery sites;
- conflict with any local policies or ordinances protecting biological resources, such as a tree preservation policy or ordinance; and
- conflict with the provisions of an adopted HCP, Natural Community Conservation Plan, or other approved local, regional, or State HCP.

An evaluation of whether an impact on biological resources would be substantial must consider both the resource itself and how that resource fits into a regional or local context. Substantial impacts would be those that would diminish, or result in the loss of, an important biological resource, or those that would obviously conflict with local, State, or federal resource conservation plans, goals, or regulations. Impacts are sometimes locally important but not significant according to CEQA. The reason for this is that although the impacts would result in an adverse alteration of existing conditions, they would not substantially diminish, or result in the permanent loss of an important resource on a population-wide or region-wide basis.

3.0 METHODS

3.1 Literature Review

Prior to conducting the biological reconnaissance survey, ECORP biologists performed a literature review using the CDFW's California Natural Diversity Data Base (CNDDDB; CDFW 2022a) and the California Native Plant Society's (CNPS') Electronic Inventory (CNPSEI; CNPS 2022) to determine the special-status plant and wildlife species that have been documented in the vicinity of the Project. The CNDDDB and CNPSEI database searches were initially conducted on September 24, 2020, and an updated literature search was performed again on April 5, 2022. ECORP searched CNDDDB and CNPSEI records within the Project Area boundaries as depicted on USGS 7.5-minute Bonds Corner, Midway Well NW, Midway Well, and Grays Well, and the surrounding topographic quadrangles: Grays Well NE, Ogilby, Cactus, Glamis SE, Glamis SW, Holtville East, Holtville West, and Calexico. The CNDDDB and CNPSEI contain records of reported occurrences of federally or state-listed endangered, threatened, proposed endangered or threatened species, California Species of Special Concern (SSC), and other special-status species or habitat that may occur within or in the vicinity of the Project. Additional information was gathered from the following sources and includes, but is not limited to:

- U.S. Department of Agriculture, Natural Resources Conservation Service (NRCS) *Web Soil Survey* (NRCS 2022a);
- *Special Animals List* (CDFW 2022b);
- *State and Federally Listed Endangered and Threatened Animals of California* (CDFW 2022c);
- *The Jepson Manual: Vascular Plants of California* (Baldwin et al. 2012);
- *The Manual of California Vegetation*, 2nd Edition (Sawyer et al. 2009); and
- various online websites (e.g., CalFlora 2022).

A desktop review of the National Wetlands Inventory (USFWS 2022a) and the corresponding USGS topographic maps was also conducted to determine if there were any blue line streams or drainages in the Survey Area that might potentially fall under the jurisdiction of either federal or State agencies.

3.2 Field Survey

3.2.1 Small Unmanned Aircraft System Survey and Vegetation Mapping

Due to the size of the area and limited road access, an initial survey utilizing a sUAS was conducted to quickly assess current solar field site conditions and gather high-resolution imagery. Upon arrival at the site, an initial field reconnaissance was conducted by the drone pilot to obtain an understanding of the site topography, access, vegetation densities, and staging areas for controlling the aerial flights. The drone was programmed to do a systematic flight over the property to collect high-resolution aerial photographs of the entire property. The photos collected were then combined into a single orthomosaic image that was incorporated into mapping files in a Geographic Information System (GIS).

The information gathered from the sUAS/drone survey were then used to assist the biologists with accurate mapping of the vegetation communities. A botanist utilized the high-resolution drone imagery to map vegetation communities. Vegetation classifications were in accordance with *A Manual of California Vegetation* (Sawyer et al. 2009). Vegetation communities that did not fit within the Sawyer classification system were described following Holland (1986) or Oberbauer (2008). Areas of the site that had already been graded, developed, and/or disturbed were mapped as such. Acreages of each vegetation community were calculated based on GIS data collected during the sUAS survey.

3.2.2 Biological Reconnaissance Survey

The biological reconnaissance survey was conducted by walking the entire Survey Area to determine the vegetation communities and wildlife habitats present within the Survey Area. Private property and inaccessible areas within the buffer were surveyed utilizing 8x42 binoculars. The biologists documented the plant and animal species present in the Survey Area and the conditions within the Survey Area were assessed for their potential to provide habitat for special-status plant and wildlife species, including those from the literature review. Data were recorded on submeter Global Positioning System (GPS) devices, data

sheets, and maps. In instances where a special-status species was observed, the date, species, location and habitat, and GPS coordinates were recorded. The locations of special-status species observations were recorded using a handheld submeter GPS in North American Datum (NAD) 83, Universal Transverse Mercator (UTM) coordinates, Zone 11S. Photographs were also taken during the survey to provide visual representation of the various vegetation communities within the Survey Area. The Survey Area was also examined to assess its potential to facilitate wildlife movement or function as a movement corridor for wildlife throughout the region.

Plant and wildlife species, including any special-status species that were observed during the survey, were recorded. Plant nomenclature follows that of *The Jepson Manual: Vascular Plants of California* (Baldwin et al. 2012). Wildlife nomenclature follows that of *The American Ornithologists' Union (AOU) Checklist of North American Birds* (AOU 2022), the Society for the Study of Amphibians and Reptiles (SSAR 2017), and the *Revised Checklist of North American Mammals North of Mexico* (Bradley et al. 2014).

3.2.3 Aquatic Resources Delineation

An aquatic resources delineation was conducted by ECORP delineation specialists in conjunction with the biological reconnaissance survey, the results of which are presented under separate cover (ECORP 2022).

3.3 Potential for Occurrence Determinations

Using information from the literature review and observations in the field, a list of special-status plant and animal species that have potential to occur within the Survey Area was generated. For the purposes of this assessment, special-status species are defined as plants or animals that:

- have been designated as either rare, threatened, or endangered by CDFW, CNPS, or the USFWS, and/or are protected under either the federal or California ESAs;
- are candidate species being considered or proposed for listing under these same acts;
- are fully protected by the California Fish and Game Code, §§ 3511, 4700, 5050, or 5515; and
- are of expressed concern to resource and regulatory agencies or local jurisdictions.

Special-status species reported for the region in the literature review or for which suitable habitat occurs on the Survey Area were assessed for their potential to occur within the Survey Area based on the following guidelines:

Present: The species was observed on site during a site visit or focused survey.

High: Habitat (including soils and elevation factors) for the species occurs within the Survey Area and a known occurrence has recently been recorded (within the last 20 years) within five miles of the area.

Moderate: Habitat (including soils and elevation factors) for the species occurs within the Survey Area and a documented observation occurs within the database search, but not within five miles of the area; a

historic documented observation (more than 20 years old) was recorded within five miles of the Survey Area; or a recently documented observation occurs within five miles of the area and marginal or limited amounts of habitat occurs in the Project Area.

Low: Limited or marginal habitat for the species occurs within the Survey Area and a recently documented observation occurs within the database search, but not within five miles of the area; a historic documented observation (more than 20 years old) was recorded within five miles of the Survey Area; or suitable habitat strongly associated with the species occurs on site, but no records or only historic records were found within the database search.

Presumed Absent: Species was not observed during a site visit or focused surveys conducted in accordance with protocol guidelines at an appropriate time for identification; habitat (including soils and elevation factors) does not exist on site; or the known geographic range of the species does not include the Survey Area.

Note: Location information on some special-status species may be of questionable accuracy or unavailable. Therefore, for survey purposes, the environmental factors associated with a species' occurrence requirements may be considered sufficient reason to give a species a positive potential for occurrence. In addition, just because a record of a species does not exist in the databases does not mean it does not occur. In many cases, records may not be present in the databases because an area has not been surveyed for that particular species.

4.0 RESULTS

Summarized below are the results of the literature review and field surveys, including site characteristics, vegetation communities, wildlife, special-status species, and special-status habitats (including any potential wildlife corridors).

4.1 Literature Review

4.1.1 *Special-Status Plants and Wildlife*

Special-status plants and wildlife species reported for the region in the literature review or for which suitable habitat occurs were evaluated for their potential to occur within the Project Area or in the buffer areas within the Survey Area where indirect impacts could occur. Of all available records, a total of 14 special-status plant species and 21 special-status wildlife species were identified as having the potential for occurrence in the vicinity of the Project Area (Attachments B and C).

4.1.2 *U.S. Fish and Wildlife Service Designated Critical Habitat*

The Project Area is not located within any USFWS designated critical habitat.

4.2 Biological Reconnaissance Survey

The biological reconnaissance survey for the solar field was conducted on September 28, 2020, by ECORP biologists Christina Congedo, Greg Hampton, Caroline Garcia, and Christina Torres. The biological

reconnaissance survey for the access road was conducted on April 12 and 13, 2022, by ECORP biologists Caroline Garcia and Christina Torres. Summarized below are the results of the biological reconnaissance survey, including site characteristics, plants and plant communities, wildlife, special-status species, and special-status habitats (including any potential wildlife corridors). Weather conditions during the surveys are summarized in Table 2.

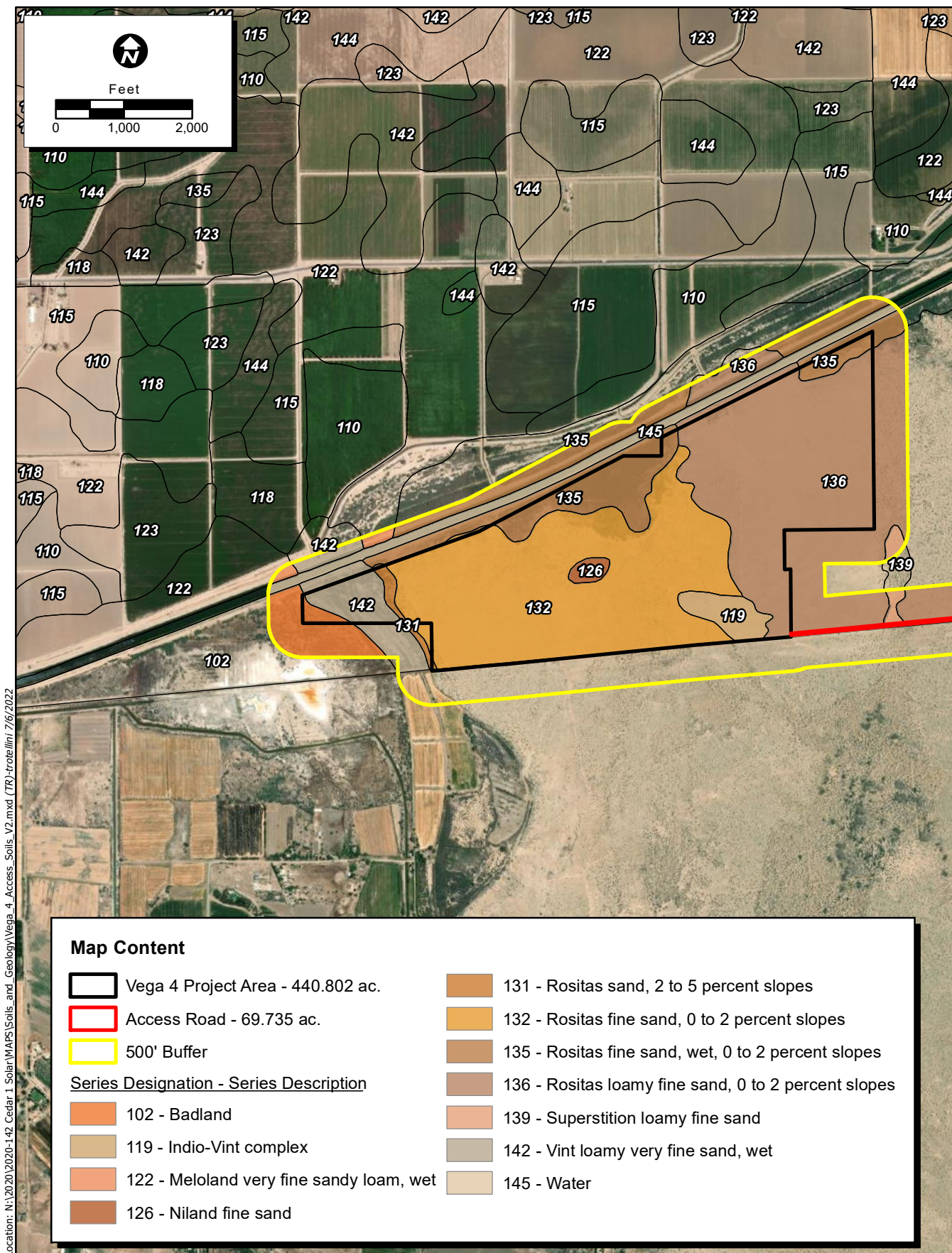
Date	Time		Temperature (°F)		Cloud Cover (%)		Wind Speed (mph)	
	Start	End	Start	End	Start	End	Start	End
9/28/2020	0715	1615	67	102	0	0	0-3	0-5
4/12/2022	0915	1650	63	73	15	3	13-18	0-12
4/13/2022	0830	1620	60	76	0	3	3-7	0-2

4.2.1 Property Characteristics

The Project Area consists of undeveloped land that appears to have been historically altered. The disturbed nature of the site, including flora composition, old agricultural foundations, and farming equipment including a center-pivot irrigation system, indicates that portions of the land may have been historically used for agricultural purposes. The eastern portion of the site consists primarily of creosote bush scrub with bordering riparian scrub and wetland habitats in the northwestern section. The Project Area is surrounded to the north and southwest by agricultural fields, and undeveloped land to the east and southeast. The All-American Canal is just north of the site and the U.S./Mexico border is located just south of the site. The access road runs east-west directly north and adjacent to the U.S./Mexico border wall. A bridge at Gordon Wells Road crosses an offline storage canal of the All-American Canal and the All-American Canal itself and connects to the 22-mile access road. Representative site photographs are included in Attachment A.

Topography throughout the Project Area is relatively flat with a matrix of subtle depressions located in the western section of the site. These depressions consist of an expansive riparian scrub community with associated wetlands and drainages. A soils analysis search was conducted using NRCS soil survey data (NRCS 2022a). Twelve soil series occur within the Project Area (Figure 3). These include:

- 102- Badland
- 111- Holtville-Imperial silty clay loams
- 119- Indio-Vint complex
- 126- Niland fine sand
- 131- Rositas sand, 2 to 5 percent slopes
- 132- Rositas fine sand, 0 to 2 percent slopes



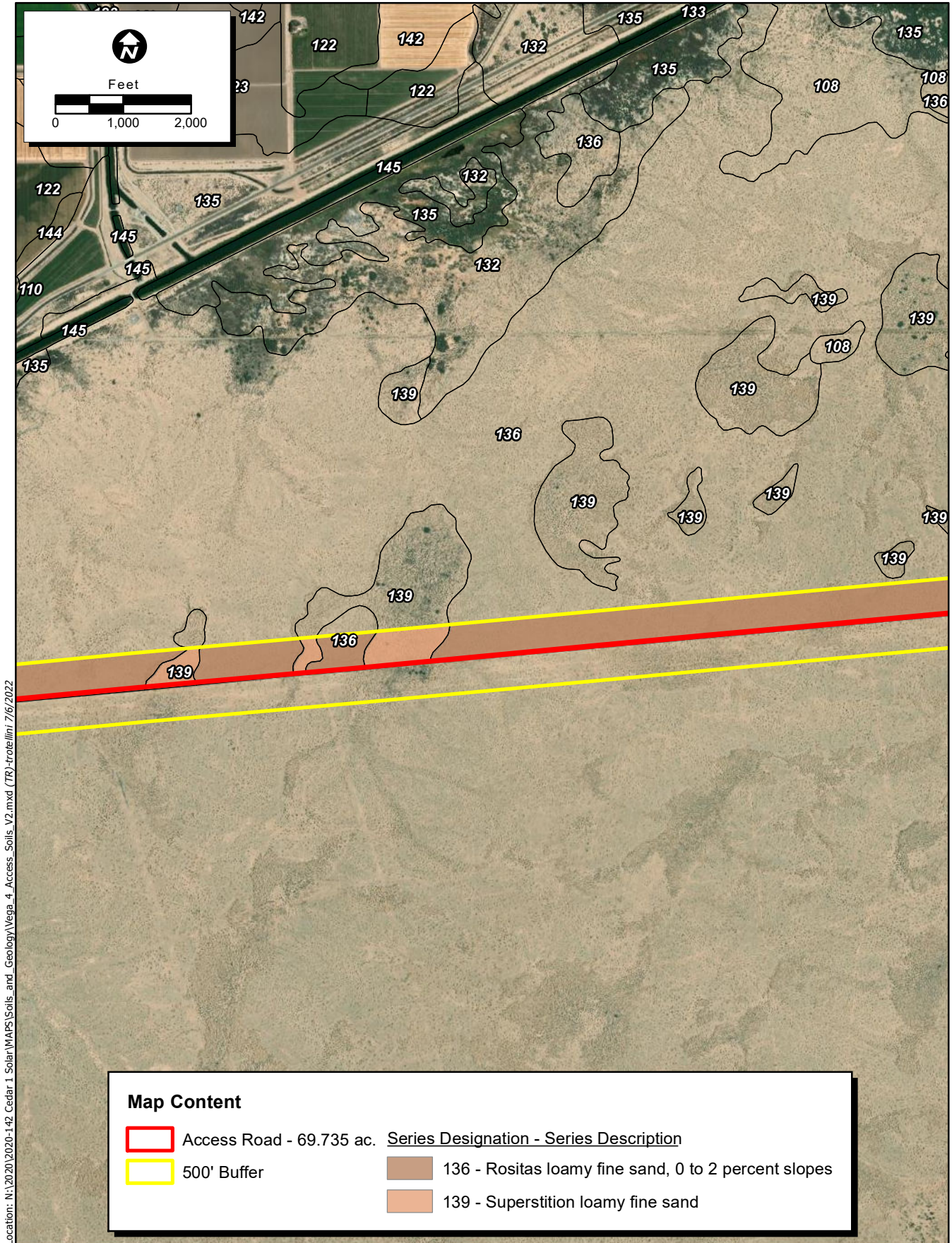
Location: N:\2020\2020-142_Cedar_1_Solar\WAPS\Soils_and_Geology\Vega_4_Access_Soils_V2.mxd (TR)-frote\lini 7/6/2022

Map Date: 7/6/2022

Service Layer Credits: Source: Esri, Maxar, Earthstar Geographic, and the GIS User Community

Figure 3. Natural Resources Conservation Service Soil Types - Sheet 1 of 9

2020-142 Vega SES 4



Location: N:\2020\2020-142_Cedar 1 Solar\WAPS\Soils_and_Geology\Vega_4_Access_Soils_V2.mxd (TR)-frote\lini 7/6/2022

Map Date: 7/6/2022

Service Layer Credits: Source: Esri, Maxar, Earthstar Geographics, and the GIS User Community

Figure 3. Natural Resources Conservation Service Soil Types - Sheet 2 of 9

2020-142 Vega SES 4

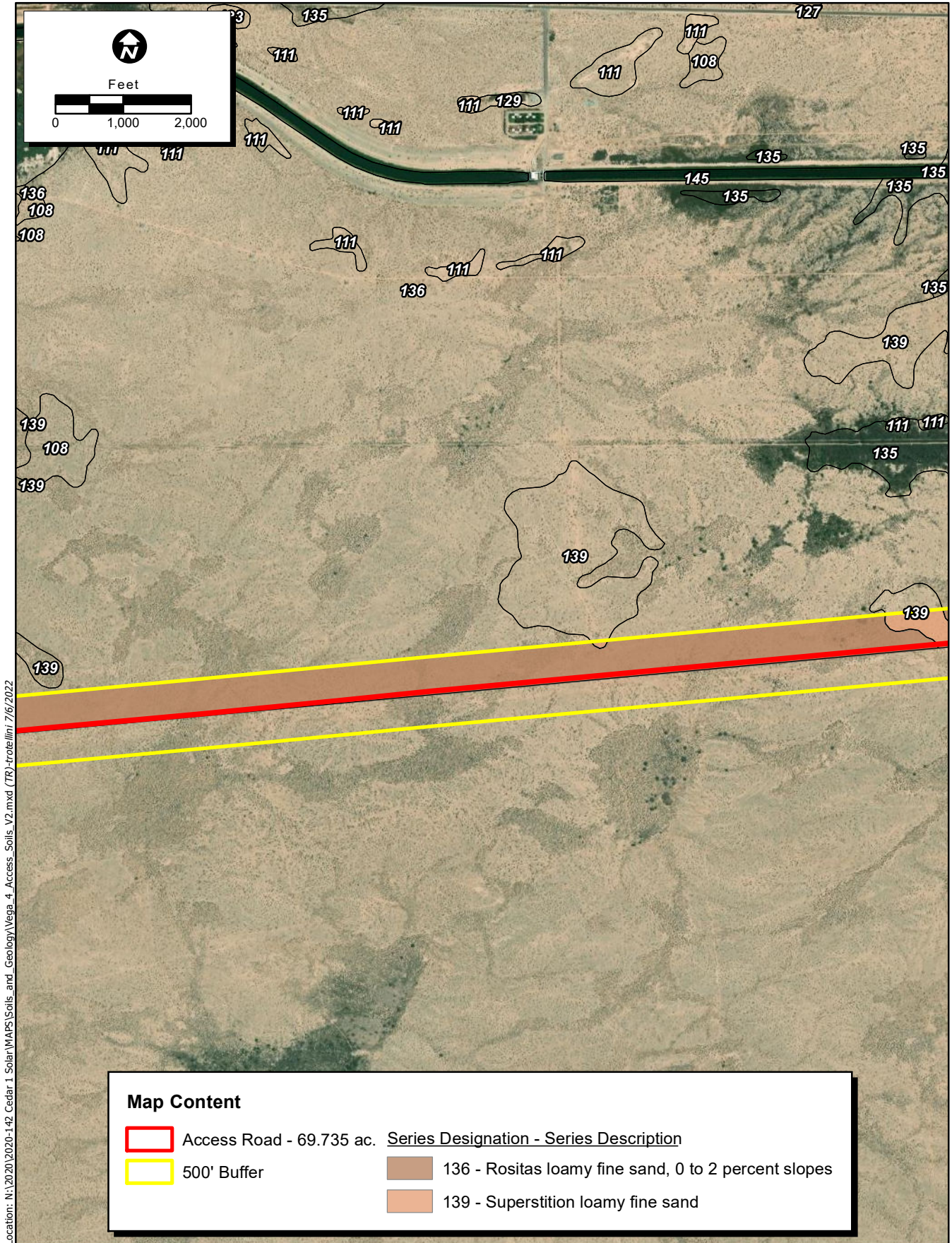
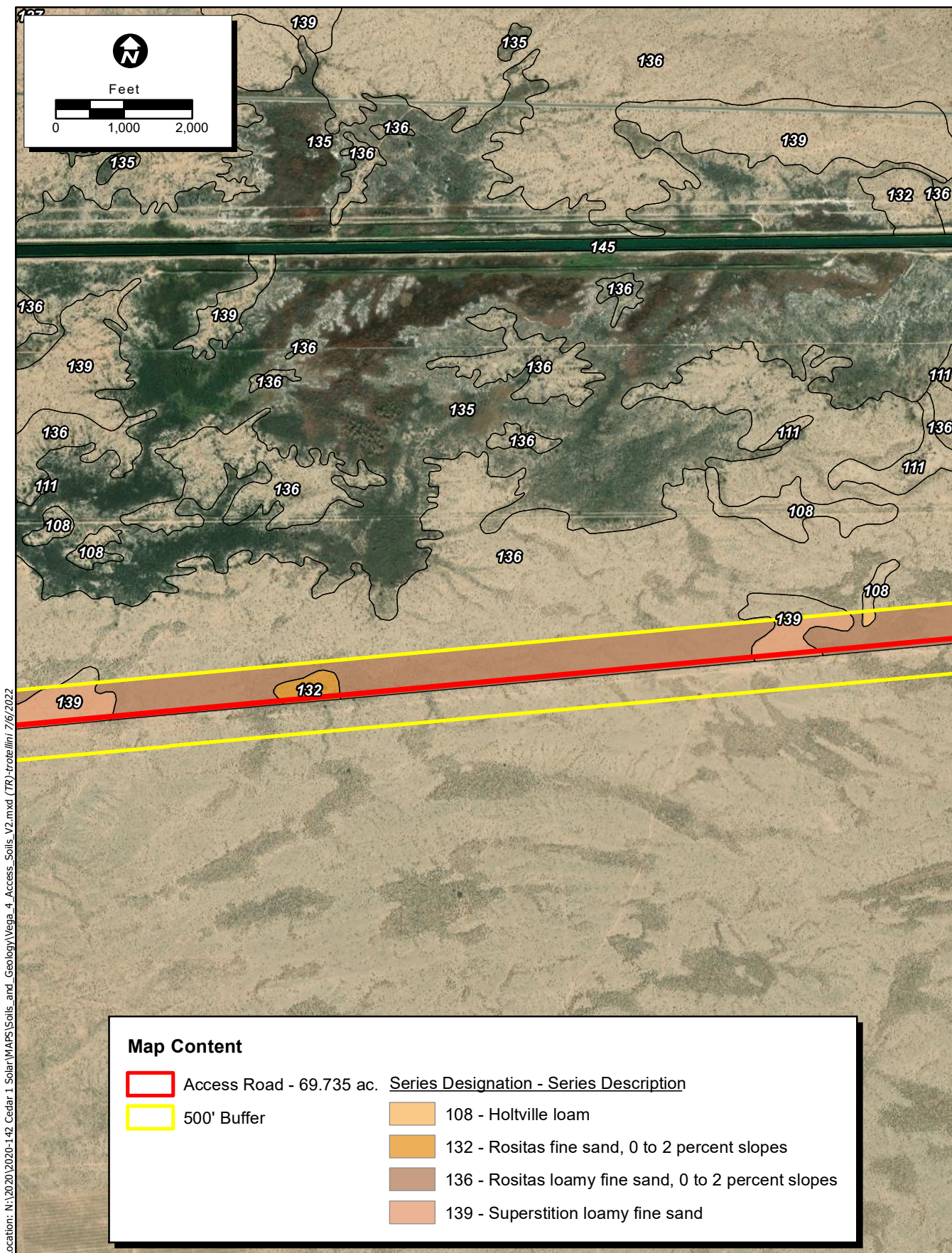


Figure 3. Natural Resources Conservation Service Soil Types - Sheet 3 of 9

2020-142 Vega SES 4



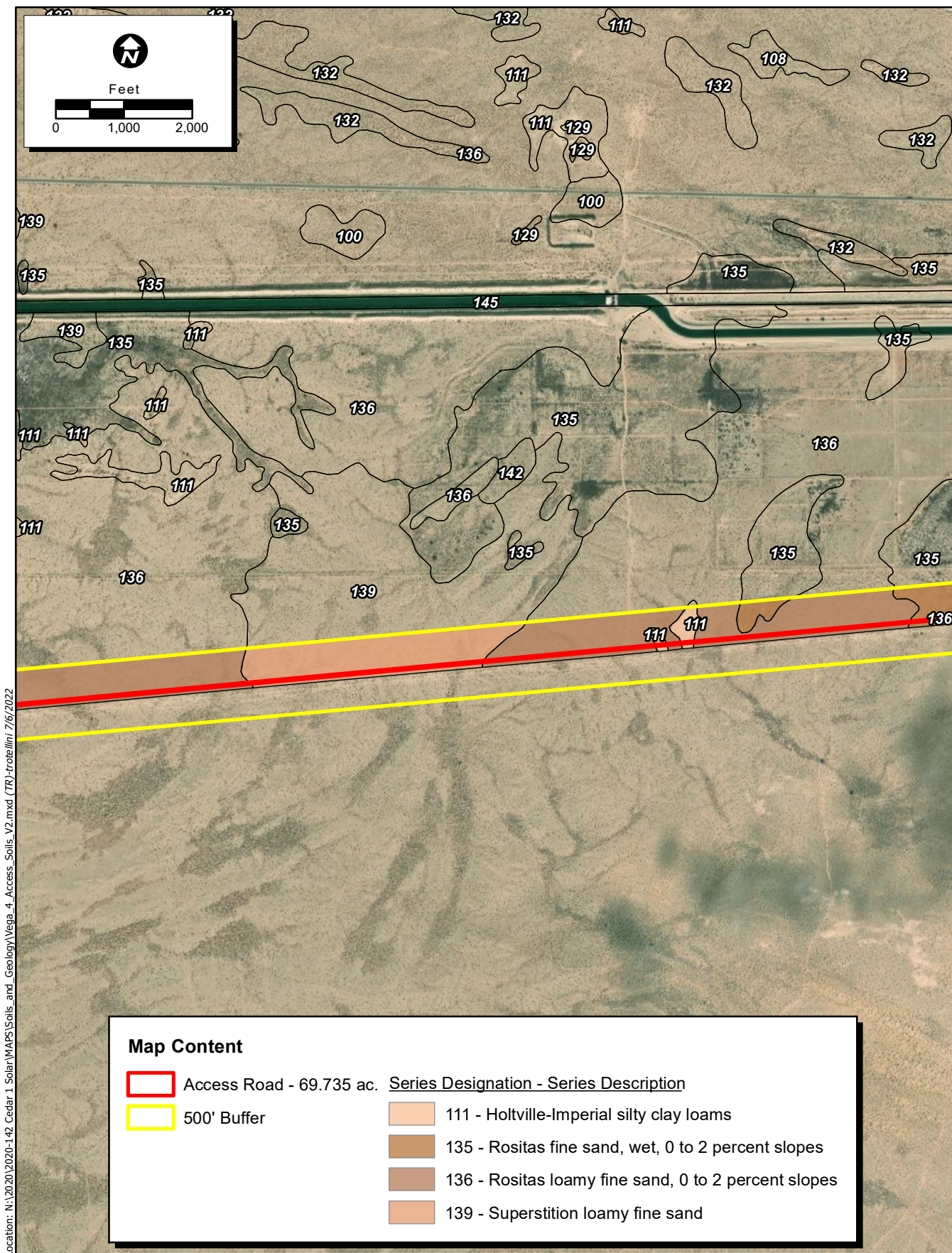
Location: N:\2020\2020-142_Cedar 1 Solar\WAPS\Soils_and_Geology\Vega_4_Access_Soils_V2.mxd (TR)-frote\liri 7/6/2022

Map Date: 7/6/2022

Service Layer Credits: Source: Esri, Maxar, Earthstar Geographics, and the GIS User Community

Figure 3. Natural Resources Conservation Service Soil Types - Sheet 4 of 9

2020-142 Vega SES 4



Location: N:\2020\2020-142_Cedar 1 Solar\WAPS\Soils_and_Geology\Vega_4_Access_Soils_V2.mxd (TR)-frote\lini 7/6/2022

Map Content		Series Designation - Series Description	
	Access Road - 69.735 ac.		111 - Holtville-Imperial silty clay loams
	500' Buffer		135 - Rositas fine sand, wet, 0 to 2 percent slopes
			136 - Rositas loamy fine sand, 0 to 2 percent slopes
			139 - Superstition loamy fine sand

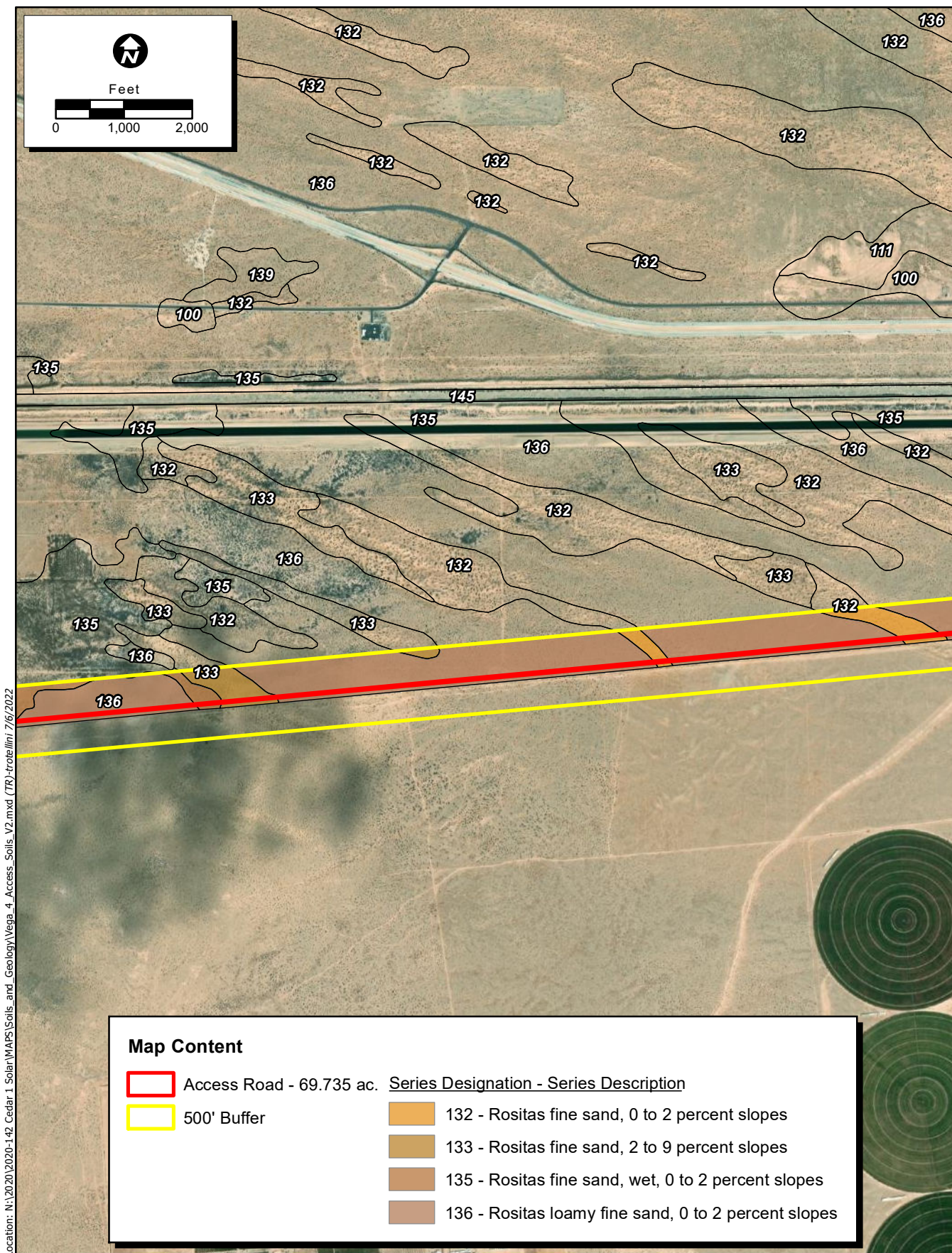
Map Date: 7/6/2022
 Service Layer Credits: Source: Esri, Maxar, Earthstar Geographics, and the GIS User Community

Figure 3. Natural Resources Conservation Service Soil Types - Sheet 5 of 9

2020-142 Vega SES 4



PC ORIGINAL PKG



Location: N:\2020\2020-142_Cedar 1 Solar\WAPS\Soils_and_Geology\Vega_4_Access_Soils_V2.mxd (TR)-frote\lini 7/6/2022

Map Date: 7/6/2022

Service Layer Credits: Source: Esri, Maxar, Earthstar Geographics, and the GIS User Community

Figure 3. Natural Resources Conservation Service Soil Types - Sheet 6 of 9

2020-142 Vega SES 4



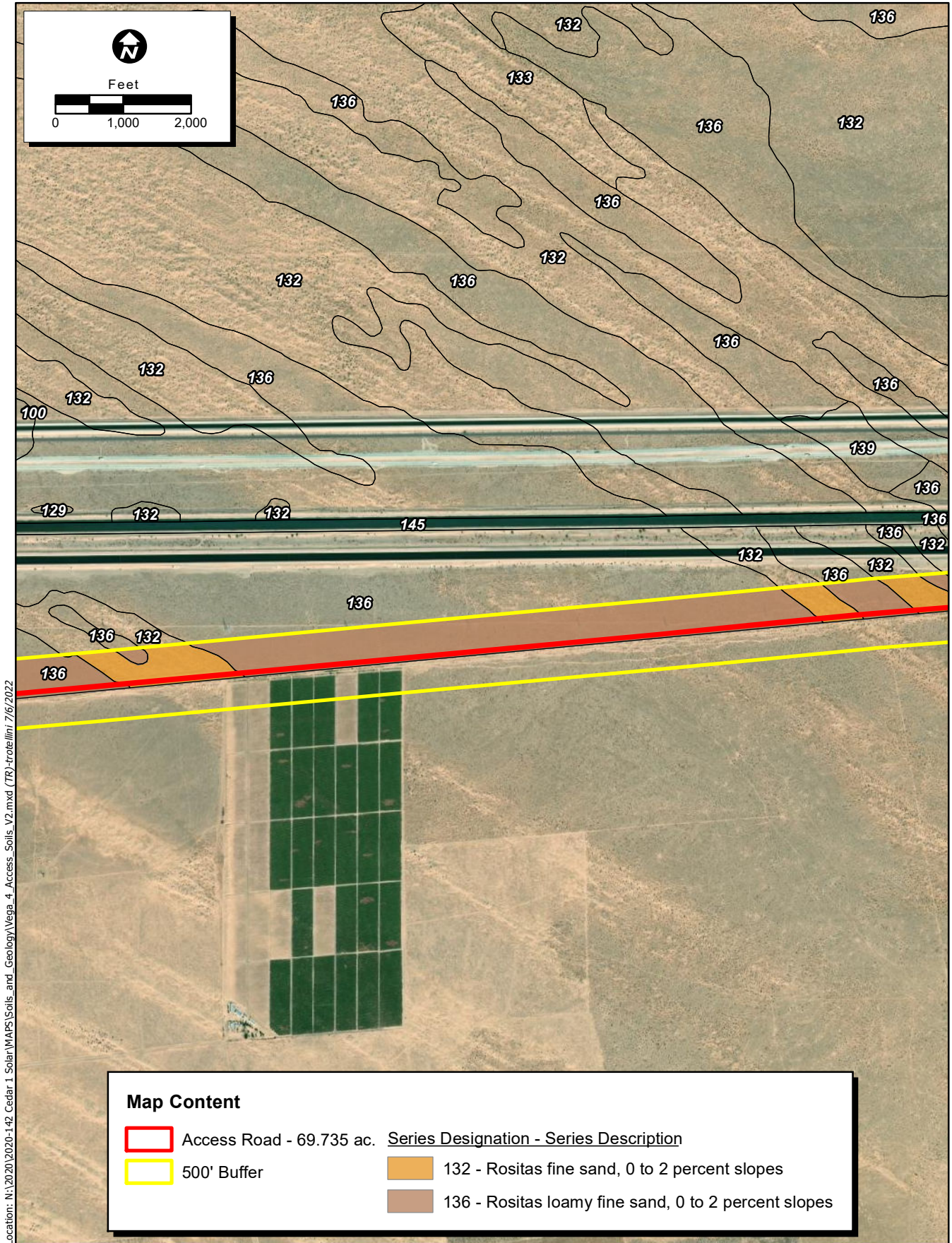
Location: N:\2020\2020-142_Cedar_1_Solar\WAPS\Soils_and_Geology\Vega_4_Access_Soils_V2.mxd (TR)-frote\liri 7/6/2022

Map Content		Series Designation - Series Description	
	Access Road - 69.735 ac.		132 - Rositas fine sand, 0 to 2 percent slopes
	500' Buffer		133 - Rositas fine sand, 2 to 9 percent slopes
			136 - Rositas loamy fine sand, 0 to 2 percent slopes

Map Date: 7/6/2022
 Service Layer Credits: Source: Esri, Maxar, Earthstar Geographics, and the GIS User Community

Figure 3. Natural Resources Conservation Service Soil Types - Sheet 7 of 9

2020-142 Vega SES 4



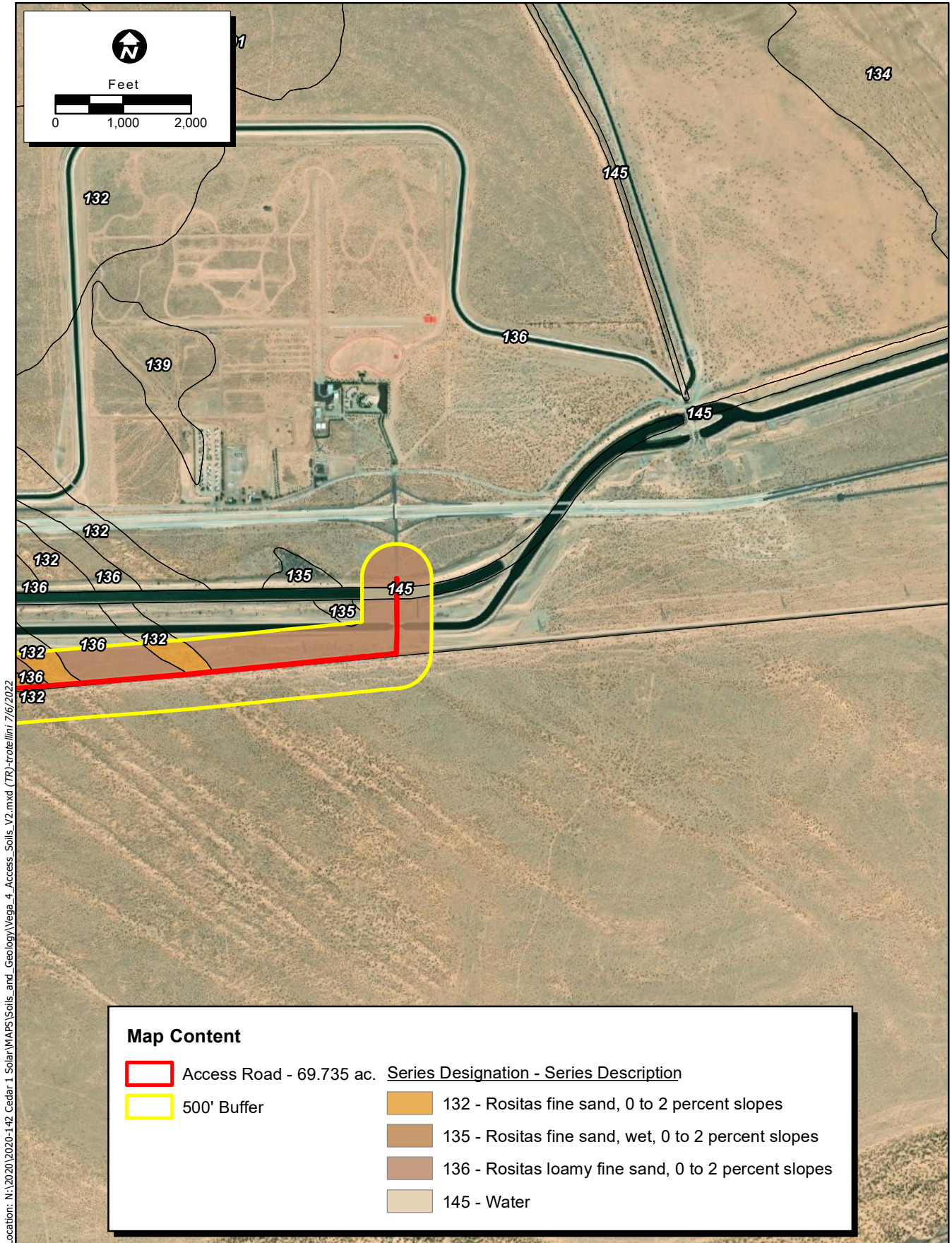
Location: N:\2020\2020-142_Cedar 1 Solar\WAPS\Soils_and_Geology\Vega_4_Access_Soils_V2.mxd (TR)-frote/lini 7/6/2022

Map Date: 7/6/2022

Service Layer Credits: Source: Esri, Maxar, Earthstar Geographics, and the GIS User Community

Figure 3. Natural Resources Conservation Service Soil Types - Sheet 8 of 9

2020-142 Vega SES 4



Location: N:\2020\2020-142_Cedar 1 Solar\WAPS\Soils_and_Geology\Vega_4_Access_Soils_V2.mxd (TR)-frote\lini 7/6/2022

Map Date: 7/6/2022

Service Layer Credits: Source: Esri, Maxar, Earthstar Geographics, and the GIS User Community

Figure 3. Natural Resources Conservation Service Soil Types - Sheet 9 of 9

2020-142 Vega SES 4

- 133- Rositas fine sand, 2 to 9 percent slopes
- 135- Rositas fine sand, wet, 0 to 2 percent slopes
- 136- Rositas loamy fine sand, 0 to 2 percent slopes
- 139- Superstition loamy fine sand
- 142- Vint loamy very fine sand, wet
- 145- Water

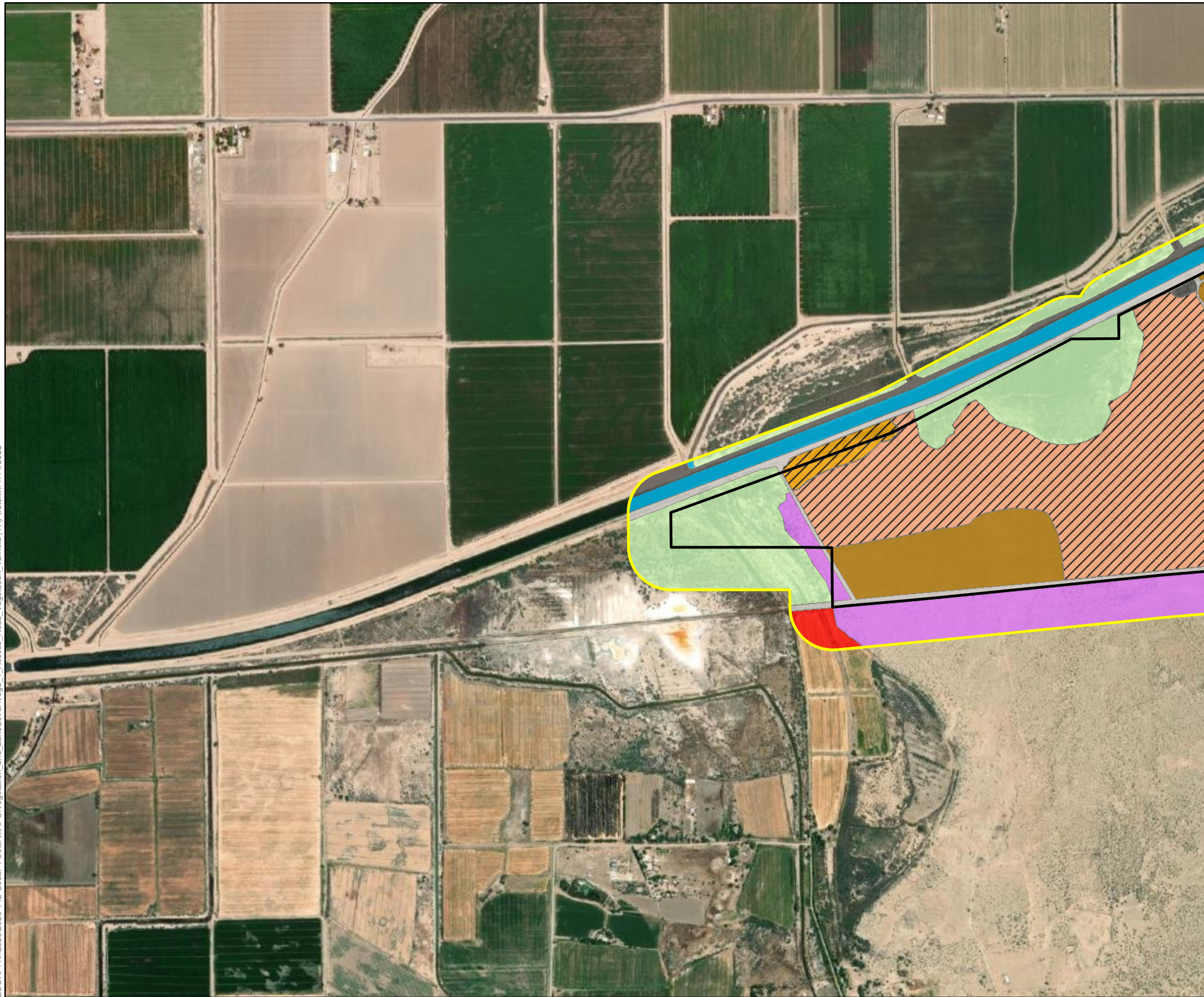
None of the aforementioned soil types contain hydric components (NRCS 2022b). Badland soils are restricted to the western portion of the site and are characterized by high runoff. Indio-Vint complex soils are restricted to the southeastern portion of the site and are characterized as having well-drained soils with low to very low surface runoff. Niland fine sand soils exist in the eastern portion of the site and are characterized as having moderately well-drained soils with low surface runoff. The Rositas series exists throughout the Project Area and is characterized as having somewhat excessively drained soils with very low surface runoff. Vint loamy very fine sand exists in the western portion of the site and is characterized as having moderately well-drained soils with very low surface runoff. Superstition loamy fine sand occurs along the access road and is characterized as having somewhat excessively drained soils. Three additional soil series occur within the survey buffer: Meloland very fine sandy loam (wet) and Holtville loam.

4.2.2 Vegetation Communities/Land Use

The majority of the Project Area consists of creosote bush – white bursage scrub (disturbed), disturbed lands, and tamarisk thickets. The location of each vegetation community in the Project Area and Survey Area are described in detail below and presented on Figure 4. Acreages of each habitat and vegetation community in the Project Area (excluding the buffer area) are shown in Table 3. Representative photographs of the habitats within the Project Area are included in Attachment A.

Vegetation Communities and Land Covers	Acres
Arrow weed thickets (disturbed)	10.41
Creosote bush scrub	9.45
Creosote bush – white bursage scrub (disturbed)	181.56
Disturbed	159.73
Tamarisk thickets	66.28
Urban/Developed	0.75
Urban/Developed – Roads	73.37
Project Area Total	501.55

ECORP: N:\2020\2020-142 Cedar 1 Solar\MAPS\Vegetation and LandCover\Vega 4 - Access_Road_Vegetation_V2.mxd (TR)-rotellini 7/14/2022



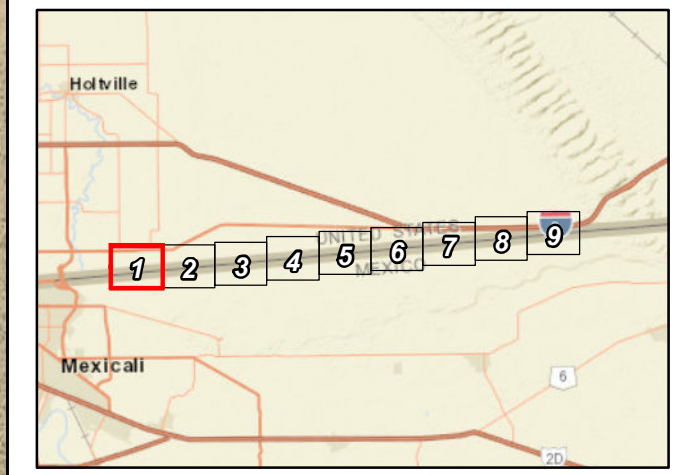
Map Features

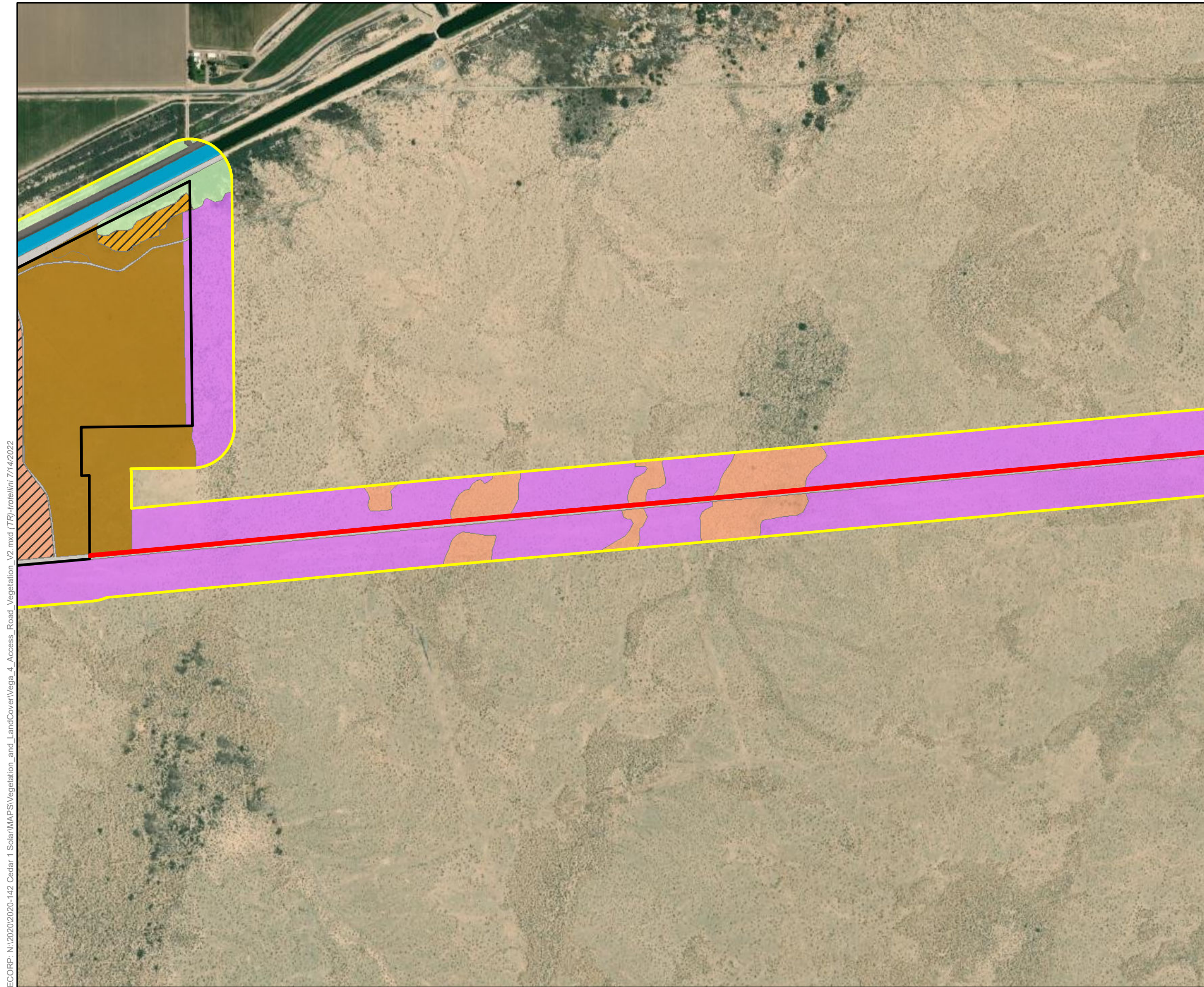
- Vega 4 Project Area - 440.802
- 500' Buffer

Vegetation Communities and Land Cover Types

- Active Agriculture
- Channel
- Creosote Bush Scrub
- Disturbed Creosote-White Bursage Scrub
- Disturbed
- Disturbed Arrow Weed Thickets
- Tamarisk Thickets
- Urban/Developed
- Urban/Developed - Dirt Road

Service Layer Credits: Sources: Esri, HERE, Garmin, USGS, Intermap, INCREMENT P, NRCan, Esri Japan, METI, Esri China (Hong Kong), Esri Korea, Esri (Thailand), NGCC, (c) OpenStreetMap contributors, and the GIS User Community





- Map Features**
- Vega 4 Project Area - 440.802
 - Access Road - 69.735 ac.
 - 500' Buffer
- Vegetation Communities and Land Cover Types**
- Channel
 - Creosote Bush Scrub
 - Creosote Bush -White Bursage Scrub
 - Disturbed Creosote-White Bursage Scrub
 - Disturbed
 - Disturbed Arrowweed Scrub
 - Tamarisk Thickets
 - Urban/Developed
 - Urban/Developed - Dirt Road

ECORP: N:\2020\2020-142 Cedar 1 Solar\MAPS\Vegetation_and_LandCover\Vega_4_Access_Road_Vegetation_V2.mxd (TR)-itolini 7/14/2022

Service Layer Credits: Sources: Esri, HERE, Garmin, USGS, Intermap, INCREMENT P, NRCan, Esri Japan, METI, Esri China (Hong Kong), Esri Korea, Esri (Thailand), NGCC, (c) OpenStreetMap contributors, and the GIS User Community

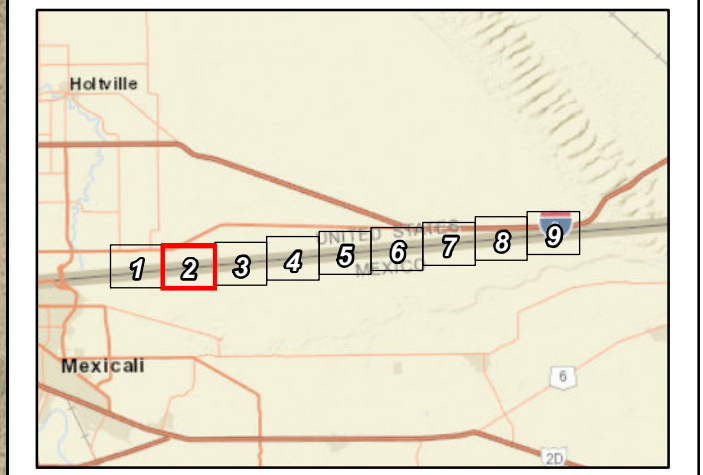
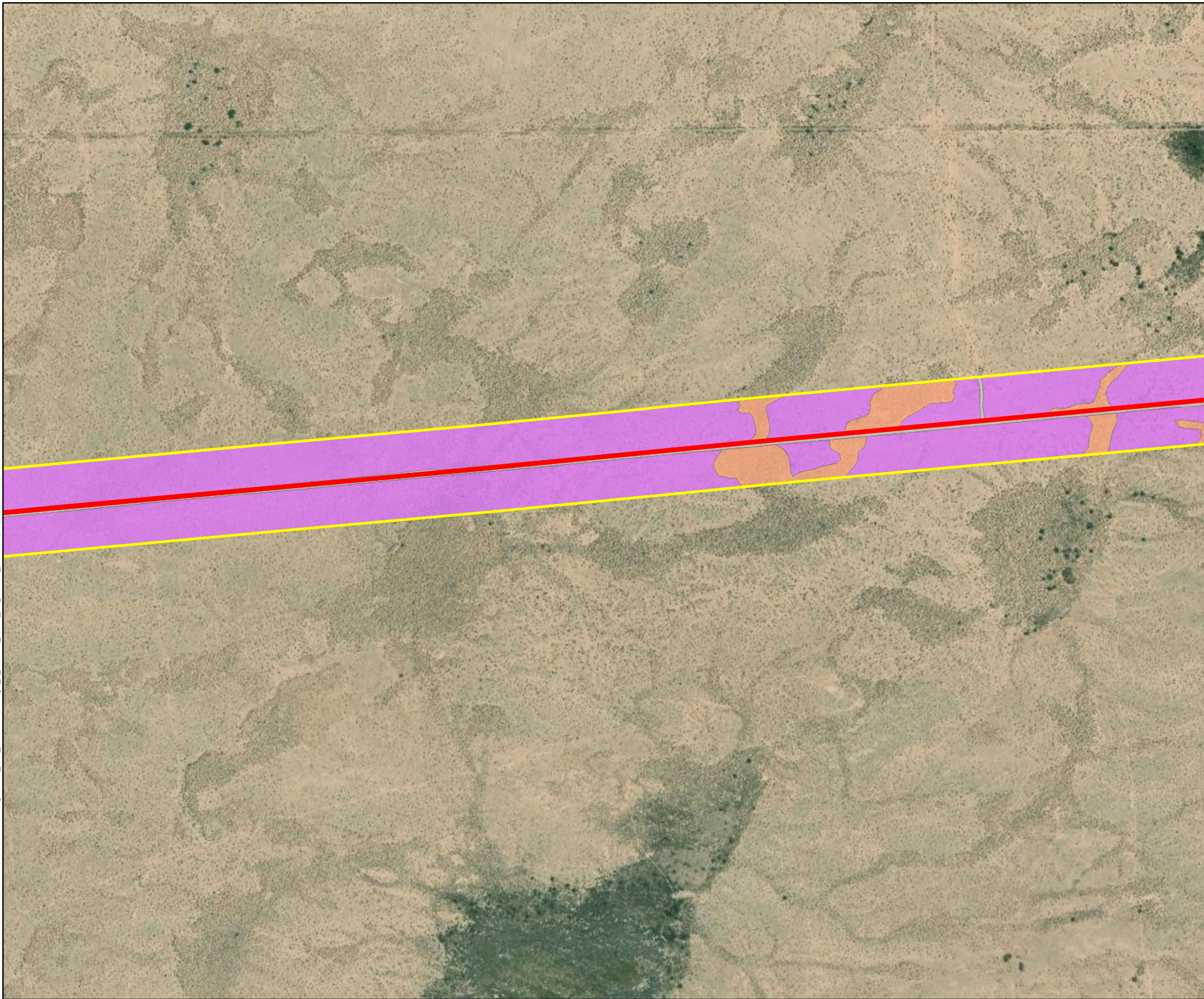


Figure 4. Vegetation Communities and Land Cover
Sheet 2 of 9
 2020-142 Vega SES 4

ECORP: N:\2020\2020-142 Cedar 1 Solar\MAPS\Vegetation_and_LandCover\Vega_4_Access_Road_Vegetation_V2.mxd (TP)-rotellini 7/14/2022



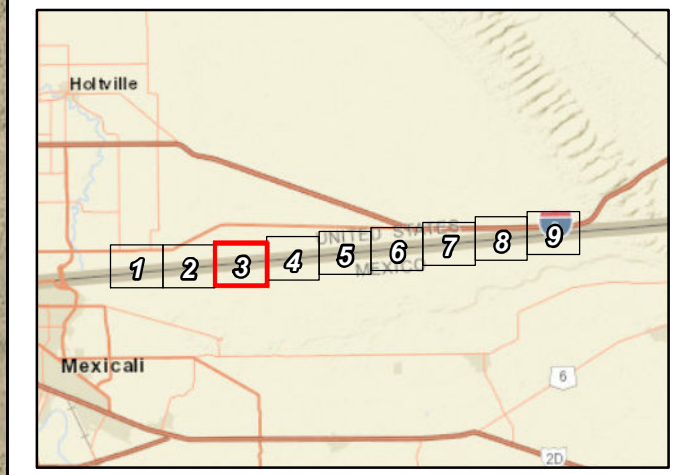
Map Features

- Access Road - 69.735 ac.
- 500' Buffer

Vegetation Communities and Land Cover Types

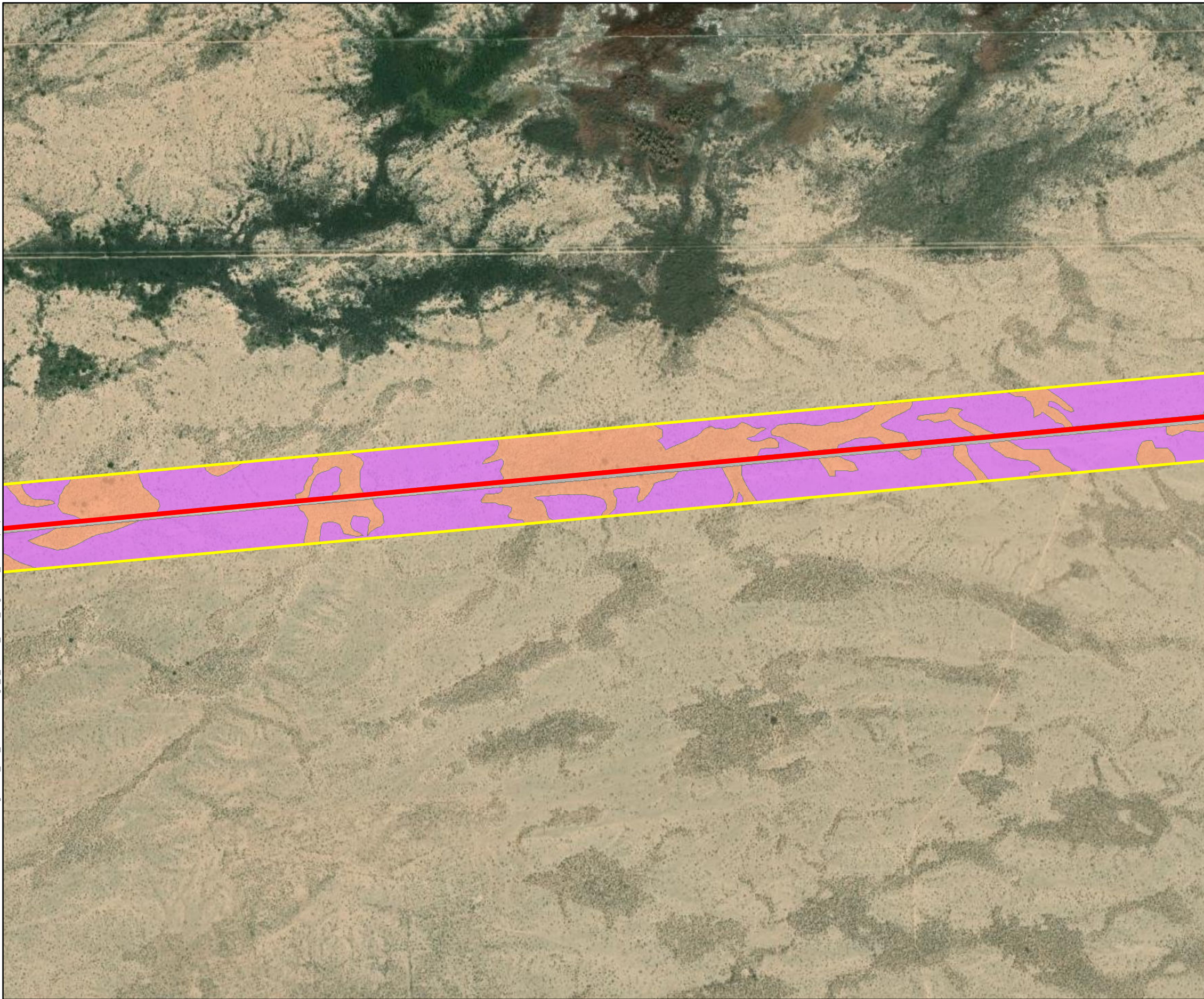
- Creosote Bush Scrub
- Creosote Bush -White Bursage Scrub
- Urban/Developed - Dirt Road

Service Layer Credits: Sources: Esri, HERE, Garmin, USGS, Intermap, INCREMENT P, NRCan, Esri Japan, METI, Esri China (Hong Kong), Esri Korea, Esri (Thailand), NGCC, (c) OpenStreetMap contributors, and the GIS User Community





Map Date: 7/6/2022




ECORP: N:\2020\2020-142 Cedar 1 Solar\MAPS\Vegetation_and_LandCover\Vega_4_Access_Road_Vegetation_V2.mxd (TJB)-jrotellini 7/14/2022



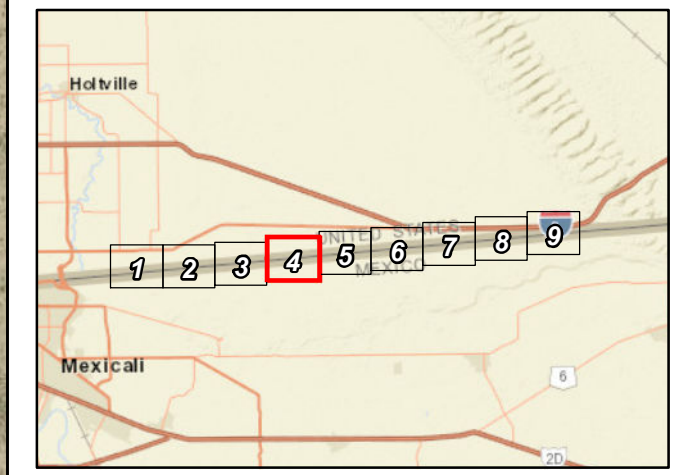
Map Features

-  Access Road - 69.735 ac.
-  500' Buffer

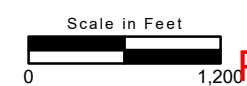
Vegetation Communities and Land Cover Types

-  Creosote Bush Scrub
-  Creosote Bush -White Bursage Scrub
-  Urban/Developed - Dirt Road

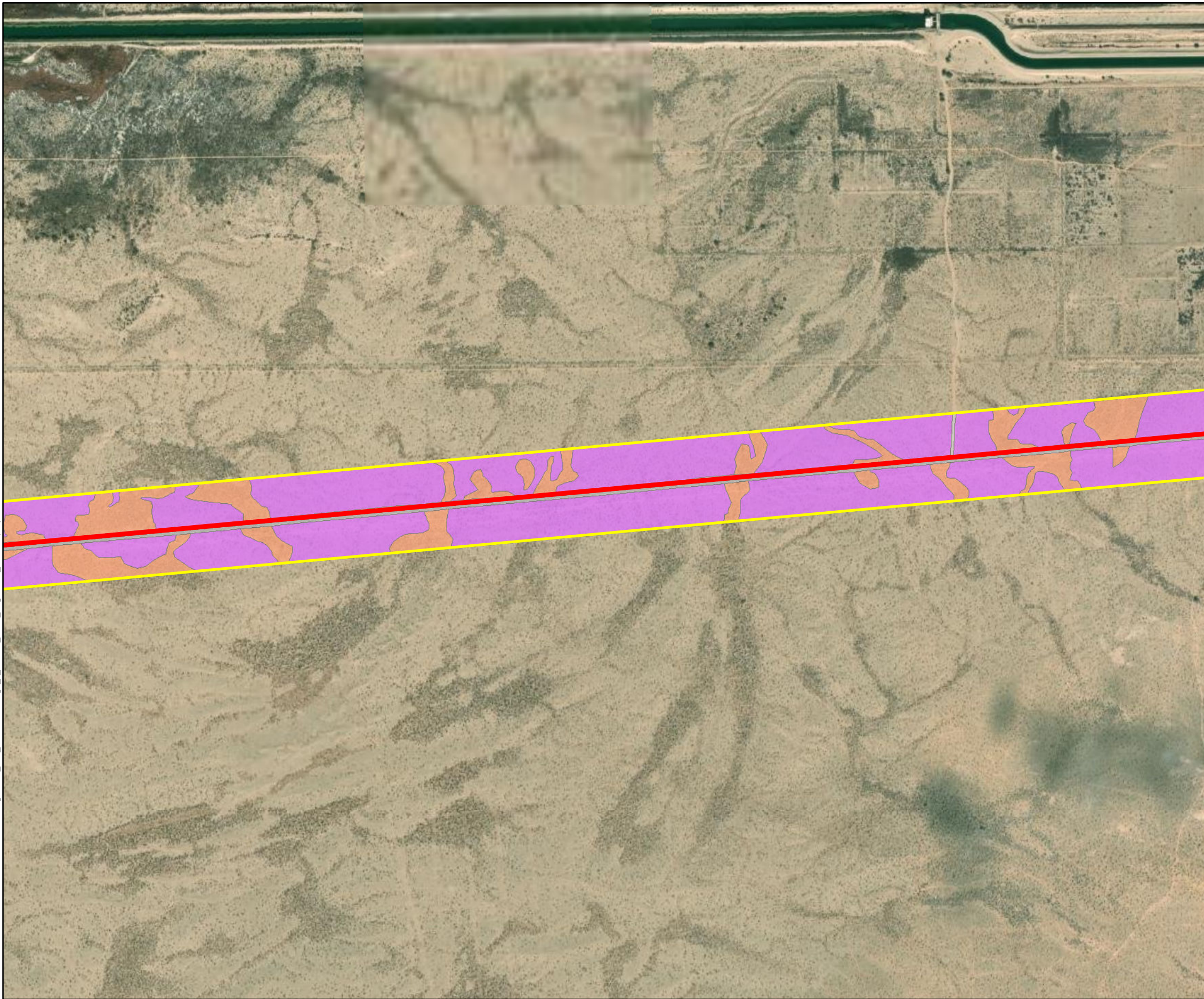
Service Layer Credits: Sources: Esri, HERE, Garmin, USGS, Intermap, INCREMENT P, NRCan, Esri Japan, METI, Esri China (Hong Kong), Esri Korea, Esri (Thailand), NGCC, (c) OpenStreetMap contributors, and the GIS User Community








Map Date: 7/6/2022

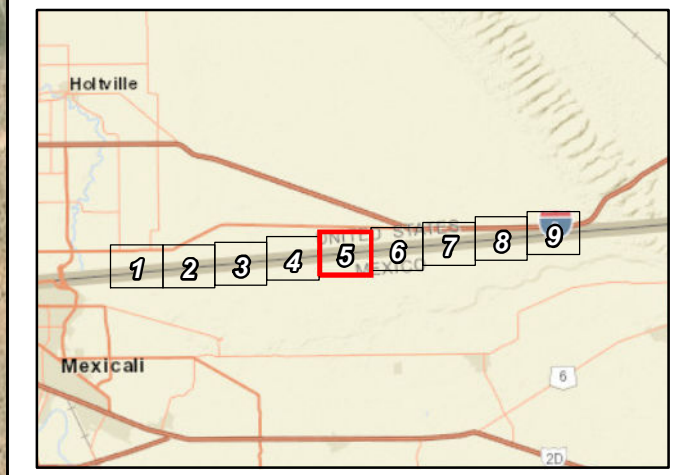


ECORP: N:\2020\2020-142 Cedar 1 Solar\MAPS\Vegetation_and_LandCover\Vega_4_Access_Road_Vegetation_V2.mxd (TP)-truelini 7/14/2022



- Map Features**
-  Access Road - 69.735 ac.
 -  500' Buffer
- Vegetation Communities and Land Cover Types**
-  Creosote Bush Scrub
 -  Creosote Bush -White Bursage Scrub
 -  Urban/Developed - Dirt Road

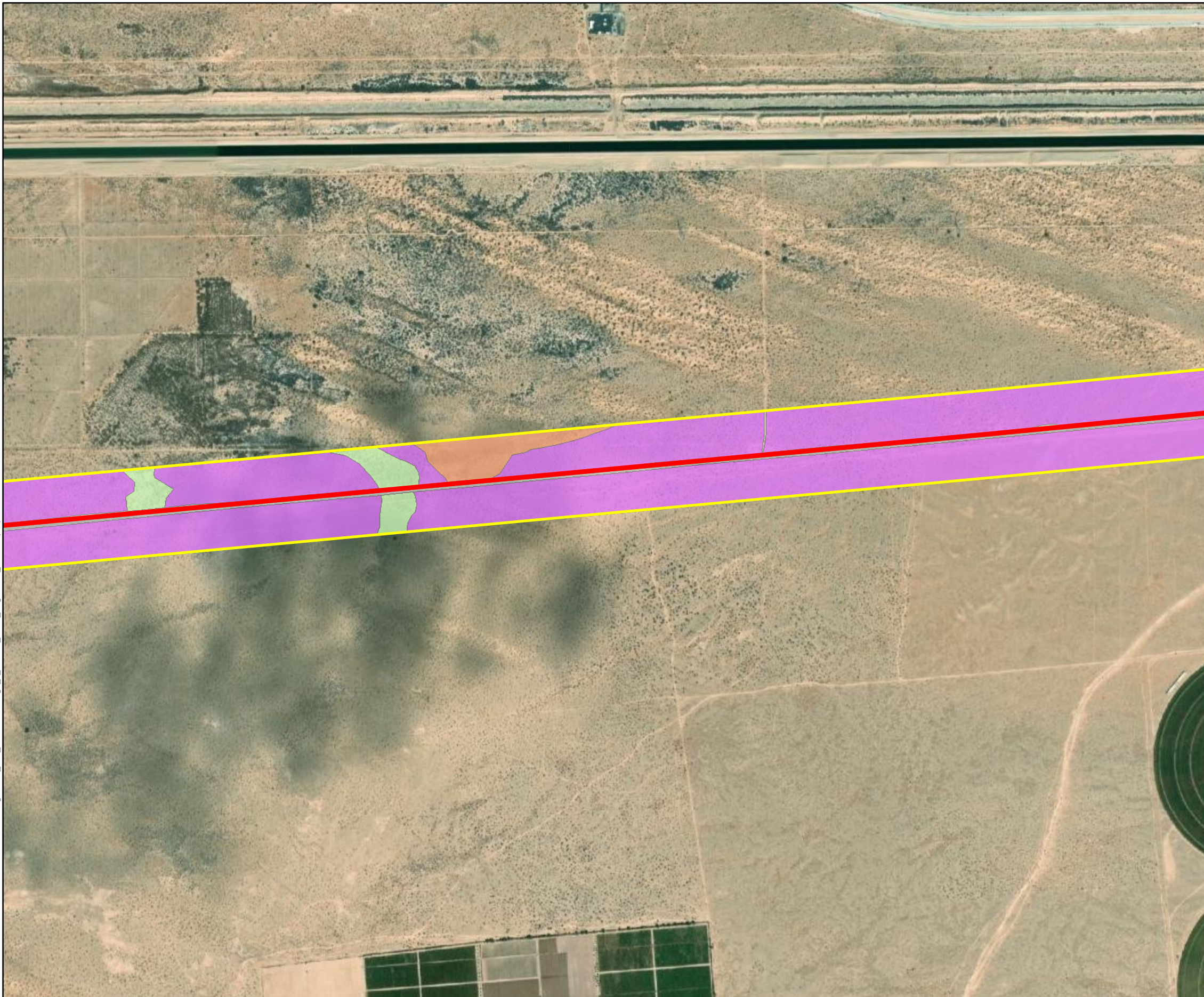
Service Layer Credits: Sources: Esri, HERE, Garmin, USGS, Intermap, INCREMENT P, NRCan, Esri Japan, METI, Esri China (Hong Kong), Esri Korea, Esri (Thailand), NGCC, (c) OpenStreetMap contributors, and the GIS User Community









Map Date: 7/6/2022



ECORP: N:\2020\2020-142 Cedar 1 Solar\MAPS\Vegetation_and_LandCover\Vega_4_Access_Road_Vegetation_V2.mxd (TP)-trtelini 7/14/2022



- Map Features**
-  Access Road - 69.735 ac.
 -  500' Buffer
- Vegetation Communities and Land Cover Types**
-  Creosote Bush Scrub
 -  Creosote Bush -White Bursage Scrub
 -  Tamarisk Thickets
 -  Urban/Developed - Dirt Road

Service Layer Credits: Sources: Esri, HERE, Garmin, USGS, Intermap, INCREMENT P, NRCan, Esri Japan, METI, Esri China (Hong Kong), Esri Korea, Esri (Thailand), NGCC, (c) OpenStreetMap contributors, and the GIS User Community

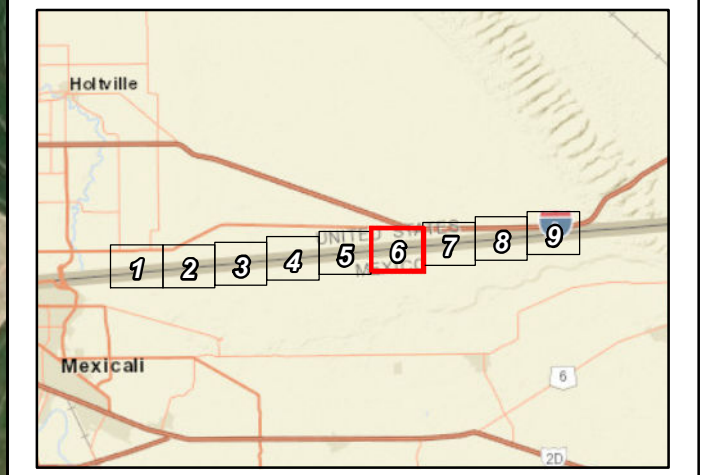
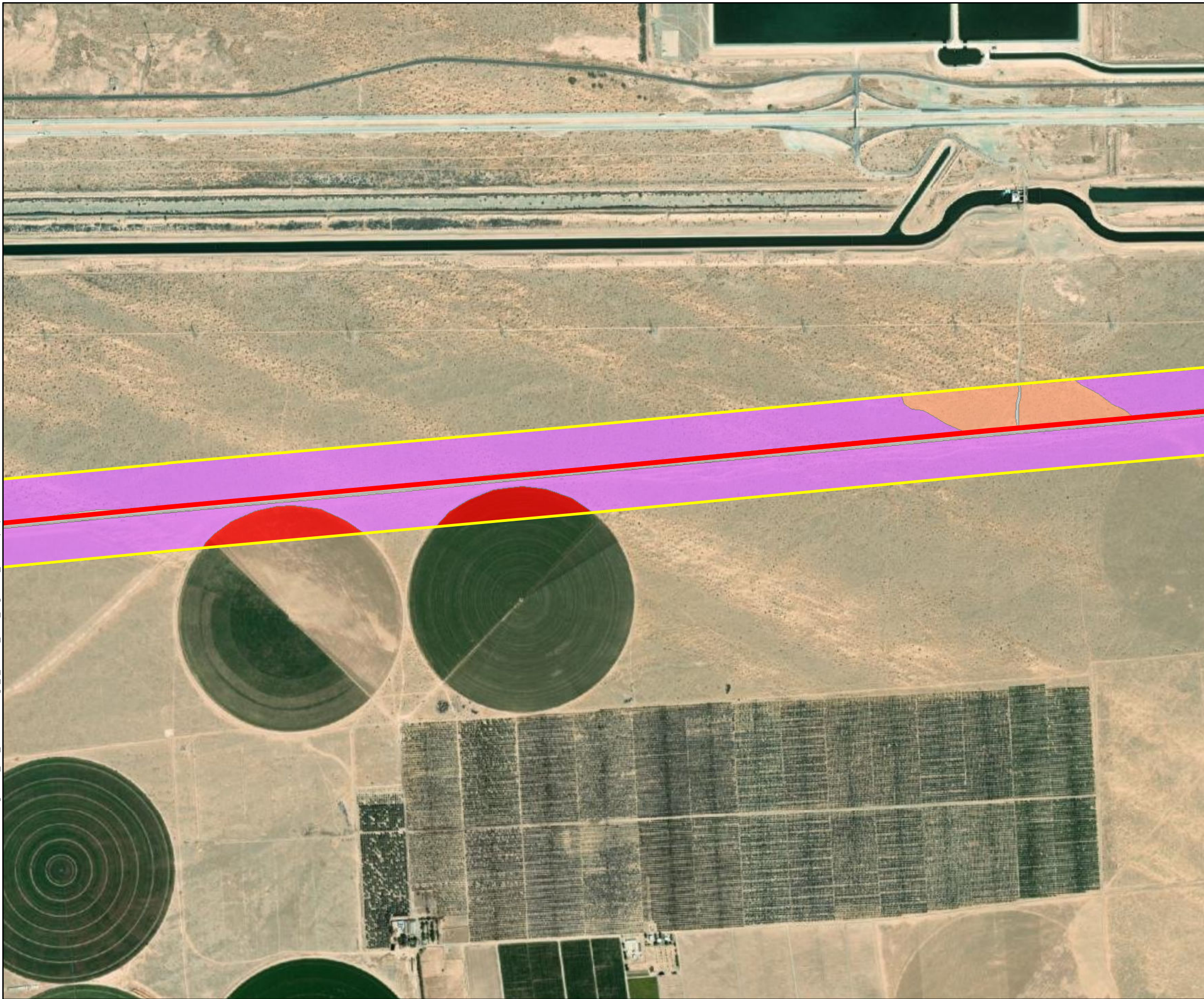


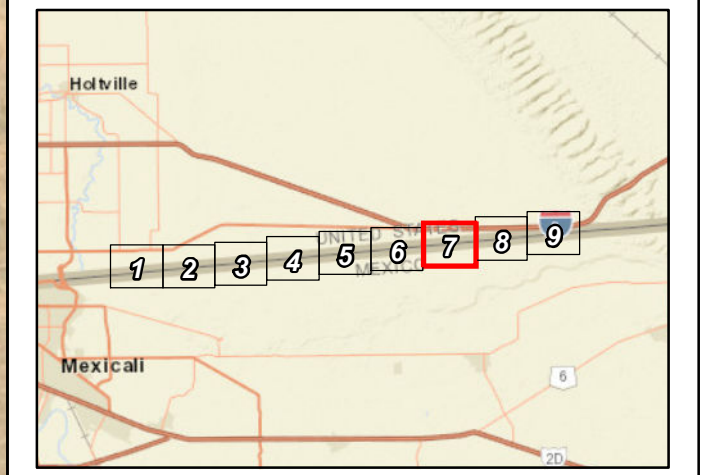
Figure 4. Vegetation Communities and Land Cover
Sheet 6 of 9
 2020-142 Vega SES 4

ECORP: N:\2020\2020-142 Cedar 1 Solar\MAPS\Vegetation and LandCover\Vega_4_Access_Road_Vegetation_V2.mxd (TJB-jrotellini 7/14/2022



- Map Features**
- Access Road - 69.735 ac.
 - 500' Buffer
- Vegetation Communities and Land Cover Types**
- Active Agriculture
 - Creosote Bush Scrub
 - Creosote Bush -White Bursage Scrub
 - Urban/Developed - Dirt Road

Service Layer Credits: Sources: Esri, HERE, Garmin, USGS, Intermap, INCREMENT P, NRCan, Esri Japan, METI, Esri China (Hong Kong), Esri Korea, Esri (Thailand), NGCC, (c) OpenStreetMap contributors, and the GIS User Community



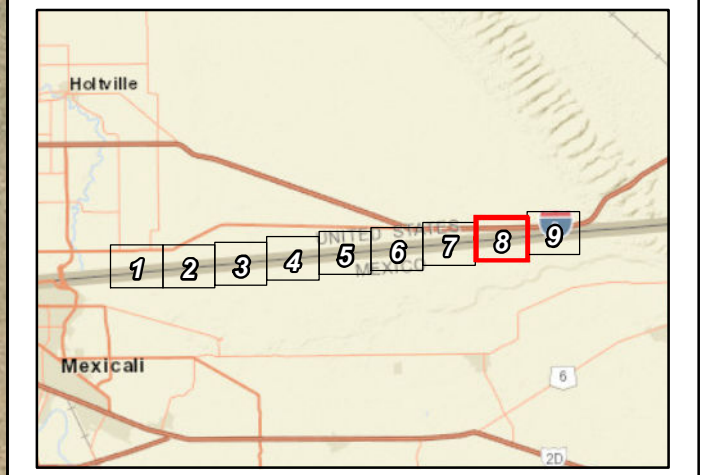
Map Date: 7/6/2022

ECORP: N:\2020\2020-142 Cedar 1 Solar\MAPS\Vegetation_and_LandCover\Vega_4_Access_Road_Vegetation_V2.mxd (TR)-jrotellini 7/14/2022

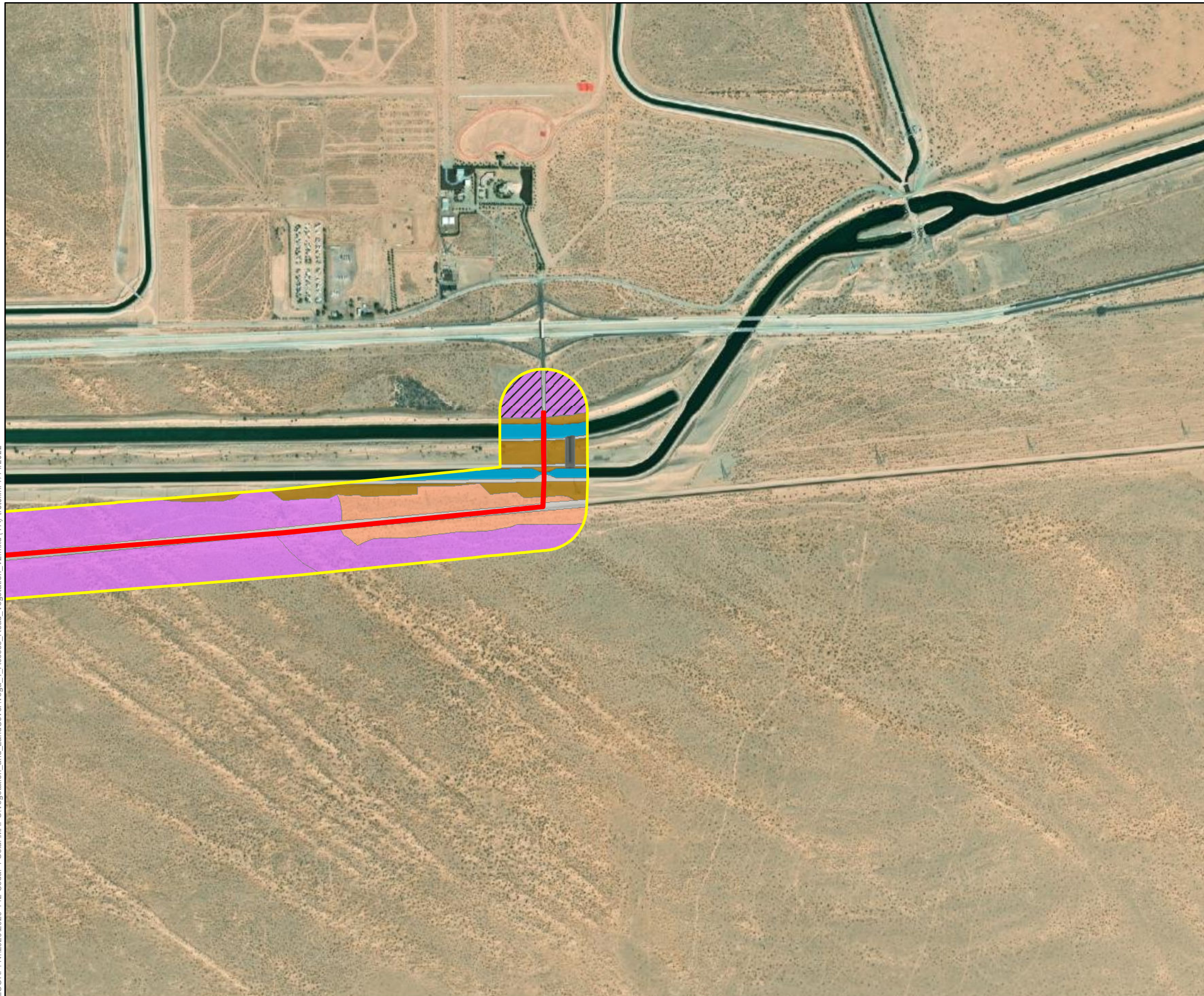


- Map Features**
- Access Road - 69.735 ac.
 - 500' Buffer
- Vegetation Communities and Land Cover Types
- Fallow Agriculture
 - Creosote Bush Scrub
 - Urban/Developed - Dirt Road

Service Layer Credits: Sources: Esri, HERE, Garmin, USGS, Intermap, INCREMENT P, NRCan, Esri Japan, METI, Esri China (Hong Kong), Esri Korea, Esri (Thailand), NGCC, (c) OpenStreetMap contributors, and the GIS User Community



ECORP: N:\2020\2020-142 Cedar 1 Solar\MAPS\Vegetation_and_LandCover\Vega_4_Access_Road_Vegetation_V2.mxd (TR)-rotellini 7/14/2022



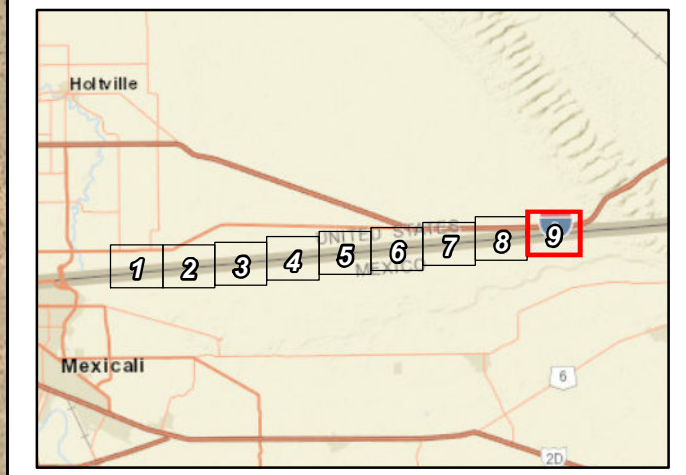
Map Features

- Access Road - 69.735 ac.
- 500' Buffer

Vegetation Communities and Land Cover Types

- Channel
- Creosote Bush Scrub
- Disturbed Creosote Bush Scrub
- Creosote Bush -White Bursage Scrub
- Disturbed
- Urban/Developed
- Urban/Developed - Dirt Road

Service Layer Credits: Sources: Esri, HERE, Garmin, USGS, Intermap, INCREMENT P, NRCan, Esri Japan, METI, Esri China (Hong Kong), Esri Korea, Esri (Thailand), NGCC, (c) OpenStreetMap contributors, and the GIS User Community



Arrow Weed Thickets (Disturbed; *Pluchea sericea* Shrubland Alliance)

Arrow weed thickets are associated with moderate to dense scrub primarily dominated by arrow weed. Other species that occur as scattered individuals include tamarisk (*Tamarix* spp.), willow baccharis (*Baccharis salicina*), and big saltbush (*Atriplex lentiformis*). This vegetation community appears around springs, seeps, irrigation ditches, canyon bottoms, seasonally flooded washed, stream banks, and within stream beds and ditches. Disturbed arrow weed thickets are arrow weed thickets that have been previously altered. On this Project, this vegetation cover is characterized as sparser. Other plant species observed included alkali goldenbush (*Isocoma acradenia*).

Creosote Bush Scrub (*Larrea tridentata* Shrubland Alliance)

Creosote bush scrub is the most characteristic vegetation of the California desert and is found on alluvial fans, bajadas, upland slopes, and washes. Creosote bush scrub is dominated by a nearly monotypic stand of creosote bush with an open canopy and an herbaceous layer of seasonal annuals and perennials. Other species that occurred on the site included white bursage (*Ambrosia dumosa*), apricot mallow (*Sphaeralcea ambigua*), and fanleaf crinklemat (*Tiquilia plicata*).

Creosote Bush – White Bursage Scrub (Disturbed; *Larrea tridentata* – *Ambrosia dumosa* Shrubland Alliance)

Disturbed creosote bush – white bursage scrub is creosote bush – white bursage scrub that has been previously altered. Creosote and white bursage are co-dominant in the shrub canopy with an absent to intermittent herbaceous layer of seasonal annuals. Within the Project Area, this vegetation cover is characterized as sparser with a high percentage of non-native plant species including common Mediterranean grass (*Schismus barbatus*) and Saharan mustard (*Brassica tournefortii*). Other plant species include dyebush (*Psoralea emoryi*) and crinklemat.

Tamarisk Thickets (*Tamarix* spp. Shrubland Semi-Natural Alliance)

Tamarisk thickets are characterized by a weedy monoculture of tamarisk. This habitat is typically in ditches, washes, rivers, arroyo margins, lake margins, and other watercourses. Within the Project Area, tamarisk and arrow weed were often co-dominant in this vegetation community. Other plant species observed included cattails (*Typha* spp.), screw bean mesquite (*Prosopis pubescens*), and willow baccharis.

Other Land Cover Types

Disturbed

Disturbed land includes areas where the native vegetation community has been heavily influenced by human actions, such as grading, trash dumping, and OHV use, but lack development. Disturbed land is not a vegetation classification, but rather a land cover type and is not restricted by elevation. On this Project, the areas consisted primarily of bare ground and Mediterranean grass. Other plant species observed on site included dyebush and white bursage.

Urban/Developed

Urban/Developed areas do not constitute a vegetation classification, but rather a land cover type. Areas mapped as developed have been constructed upon or otherwise physically altered to an extent that natural vegetation communities are no longer supported. There may be irrigated, landscaped ornamental species present between the hardscape. Within the Project Area, this land cover was dominant and consisted primarily of compacted dirt roads, structures, and landscape trees including Mexican fan palm (*Washingtonia robusta*) and Mexican palo verde (*Parkinsonia aculeata*). The entirety of the access road is this land cover type.

Vegetation Communities within Survey Area

Four additional vegetation communities were observed within the survey buffer, but not within the Project Area. These land covers are described in detail below. No impacts to these vegetation communities and land covers are expected as a result of Project-related activities.

Creosote Bush – White Bursage Scrub (Larrea tridentata – Ambrosia dumosa Shrubland Alliance)

Creosote bush – white bursage scrub consists of creosote and white bursage that are co-dominant in the shrub canopy with an absent to intermittent herbaceous layer of seasonal annuals. This community was observed adjacent to the access road. Other plant species observed within this community include ephedras (*Ephedra trifurca* and *Ephedra* sp.), alkali goldenbush, and scattered individuals of mesquite.

Creosote Bush Scrub (Disturbed; Larrea tridentata Shrubland Alliance)

Disturbed creosote bush scrub is creosote bush scrub that has been previously altered. This community was observed north of the bridge that spans the All-American Canal and had visible signs of disturbance such as tire tracks and trash. Vegetation within this community was sparser. Other plant species observed include ephedra and crinklemat.

Active Agriculture

Active agriculture includes planted, typically monotypic rows of crops of annual and perennial species with open space between rows. Species composition frequently changes by season and year. Active agriculture often occurs in upland areas with high soil quality, or floodplains and are almost always artificially irrigated. This land cover was observed in the western buffer areas and south of the access road within the country of Mexico.

Fallow Agriculture

Fallow agricultural lands include remnant signs of row crops with open space between rows. Agricultural lands often occur in upland areas with high soil quality, or floodplains, and are almost always artificially irrigated. This land cover was observed periodically to the south of the access road within the country of Mexico. Access to view these areas was obstructed by the U.S./Mexico border wall, but unvegetated row crops were observed from a distance.

4.2.3 Wildlife Observed

Wildlife species observed included zebra-tailed lizard (*Callisaurus draconoides*), great basin whiptail (*Aspidoscelis tigris tigris*), northern harrier (flyover; *Circus hudsonius*), western burrowing owl (*Athene cunicularia hypugaea*), loggerhead shrike (*Lanius ludovicianus*), black-tailed gnatcatcher (*Polioptila melanura*), yellow warbler (*Setophaga petechia*), great egret (*Ardea alba*), American kestrel (*Falco sparverius*), lesser nighthawk (*Chordeiles acutipennis*), ash-throated flycatcher (*Myiarchus cinerascens*), Gambel's quail (*Callipepla gambelii*), Abert's towhee (*Melospiza aberti*), European starling (*Sturnus vulgaris*), killdeer (*Charadrius vociferus*), turkey vulture (*Cathartes aura*), verdin (*Auriparus flaviceps*), great-tailed grackle (*Quiscalus mexicanus*), horned lark (*Eremophila alpestris*), black-necked stilt (*Himantopus mexicanus*), mourning dove (*Zenaida macroura*), greater roadrunner (*Geococcyx californianus*), black phoebe (*Sayornis nigricans*), Say's phoebe (*Sayornis saya*), house finch (*Haemorhous mexicanus*), white-crowned sparrow (*Zonotrichia leucophrys*), Anna's hummingbird (*Calypte anna*), great blue heron (*Ardea herodias*), lesser goldfinch (*Spinus psaltria*), cliff swallow (*Petrochelidon pyrrhonota*), common raven (*Corvus corax*), northern mockingbird (*Mimus polyglottos*), great egret (*Ardea alba*), mallard (*Anas platyrhynchos*), black-tailed jackrabbit (*Lepus californicus*), desert cottontail (*Sylvilagus audubonii*), and signs of coyote (*Canis latrans*), antelope ground squirrel (*Ammospermophilus leucurus*), raccoon (*Procyon lotor*) and bat (Order Chiroptera).

During the 2022 assessment of the access road, a bat roost was observed within the bridge at Gordon Wells Road that crosses the offline storage canal, north of the All-American Canal. This bridge is located at the furthest eastern extent of the access road. Several bats could be heard vocalizing within the bridge and a substantial amount of guano was observed beneath the bridge where surfaces were dry. Species determination and size of the colony would require further analysis via a combination of acoustic monitoring and nighttime emergence surveys. Due to the quantity of bats heard and the time of year of the observation, there is high likelihood that this is a maternity roost. Cliff swallows were also observed nesting along both sides of the aforementioned bridge. Cliff swallows are not a special-status species.

4.3 Special-Status Species Assessment

The literature review resulted in 14 special-status plant and 21 special-status wildlife species that have historically been recorded in the vicinity of the Project or that are highly associated with habitat that occurs within the Project Area. Special-status plants were evaluated for their potential to occur within the Project Area where impacts could occur. Special-status wildlife were evaluated for their potential to occur within the Survey Area, a broader area that includes the Project Area and buffer, where direct or indirect impacts could occur.

4.3.1 Plants

Numerous special-status plant species have been recorded within five miles of the Project Area, according to the CNDDDB (CDFW 2022a), IPaC (USFWS 2022b), and CNPSEI (CNPS 2022). Of all available records, a total of 14 species were identified as those with the potential for occurrence within the vicinity of the Project Area. Descriptions of the CNPS designations are found in Table 4 and a list of the special-status plant species identified in the literature review is presented following Table 4.

Table 4. CNPS Status Designations	
List Designation	Meaning
1A	Plants Presumed Extirpated in California and Either Rare or Extinct Elsewhere
1B	Plants Rare, Threatened, or Endangered in California and Elsewhere
2A	Plants Presumed Extirpated in California, But Common Elsewhere
2B	Plants Rare, Threatened, or Endangered in California, But More Common Elsewhere
3	Plants about which we need more information; a review list
4	Plants of limited distribution; a watch list
List 1B, 2, and 4 extension meanings:	
.1	Seriously threatened in California (over 80 percent of occurrences threatened / high degree and immediacy of threat)
.2	Moderately threatened in California (20-80 percent occurrences threatened / moderate degree and immediacy of threat)
.3	Not very threatened in California (less than 20 percent of occurrences threatened / low degree and immediacy of threat or no current threats known)

Note: According to CNPS (Skinner and Pavlik 1994), plants on Lists 1B and 2 meet definitions for listing as threatened or endangered under Section 1901, Chapter 10 of the California Fish and Game Code (California Department of Fish and Game [CDFG] 1984). This interpretation is inconsistent with other definitions.

Plant Species with a Moderate Potential to Occur

Due to the presence of suitable habitat and several known occurrences within five miles of the Project Area, the following species was determined to have a moderate potential to occur:

- Abrams' spurge (*Euphorbia abramsiana*) is a CNPS Rare Plant Rank (CRPR) 2B.2 plant species. This species is known to occur at elevations between 50 and 100 meters (164 and 328 feet) and blooms between September – November. Abrams' spurge is known to occur in creosote scrub habitat within sandy flats including playas, fields, disturbed areas, and washes. One historic CNDDDB record was located approximately three miles west of the Project Area near the Alamo River. Potential habitat occurs within the Project Area for this species in the creosote bush scrub and the disturbed creosote bush – white bursage scrub habitats.
- Wiggins' croton (*Croton wigginsii*) is a CRPR 2B.2 plant species. This species is known to occur at elevations between 50 and 100 meters (164 and 328 feet) and blooms between March and May. Wiggins' croton is known to occur in sandy Sonoran desert scrub habitat. Two historic CNDDDB records were recorded with the closest being from 1993 located approximately 0.92 miles east of the Project Area. Potential habitat occurs within Project Area for this species in the sandy, creosote bush scrub and the disturbed creosote bush – white bursage scrub habitats.

- Sand food (*Pholisma sonora*) is a CRPR 1B.2 plant species. This parasitic species attaches to the roots of host *Eriogonum*, *Tiquilia*, *Ambrosia*, and *Pluchea* species. Sand food is known to occur at elevations between sea level and 200 meters (sea level and 656 feet) and blooms between April and June. It is known to occur in sandy Sonoran desert scrub habitat. One historic CNDDDB record from 1954 was recorded approximately 0.5 mile north of the Project Area. Potential habitat occurs within the Project Area for this species in the sandy, creosote bush scrub and the disturbed creosote bush – white bursage scrub habitats.

Plant Species with Low Potential to Occur

The following species were found to have a low potential to occur within the Project Area because of limited habitat for the species on the site and a known occurrence has been reported in the database, but not within five miles of the Project Area, or suitable habitat strongly associated with the species occurs within the Project Area, but no records were found in the database search:

- Watson's amaranth (*Amaranthus watsonii*), CRPR 4.3
- Peirson's milk-vetch (*Astragalus magdalena* var. *peirsonii*), federally listed threatened, state-listed endangered, CRPR 1B.2
- gravel milk-vetch (*Astragalus sabulonum*), CRPR 2B.2
- Algodones Dunes sunflower (*Helianthus niveus* ssp. *tephrodes*), state-listed endangered, CRPR 1B.2
- California satintail (*Imperata brevifolia*), CRPR 2B.1
- ribbed cryptantha (*Johnstonella costata*), CRPR 4.3
- winged cryptantha (*Johnstonella holoptera*), CRPR 4.3
- hairy stickleaf (*Mentzelia hirsutissima*), CRPR 4.3
- Darlington's blazing star (*Mentzelia puberula*), CRPR 2B.2
- slender cottonheads (*Nemacaulis denudata* var. *gracilis*), CRPR 2B.2
- giant Spanish-needle (*Palafoxia arida* var. *gigantea*), CRPR 1B.3

4.3.2 Wildlife

The literature search documented 21 special-status wildlife species in the vicinity of the Project Area, two of which are federally and/or state-listed. Of the 21 special-status wildlife species identified in the literature review, five were present within the Project Area, two were found to have a high potential to occur, seven were found to have a moderate potential to occur and three were found to have a low potential to occur; the remaining three species are presumed absent from the Project Area. Descriptions of the federal and state wildlife designations are found in Table 5, and a brief natural history and

discussion of the special-status wildlife species found onsite that have a high or moderate potential to occur within the Project Area are provided below.

Table 5. Wildlife Status Designations	
List Designation	Meaning
Federal Designation	Jurisdiction under United States Fish and Wildlife Service (USFWS)
END	Federally listed as Endangered
THR	Federally listed as Threatened
CAN	Federal Candidate Species
FSC	Federal Species of Concern
FPD	Federal Proposed for Delisting
BBC	Bird of Conservation Concern
State Designation	Jurisdiction under California Fish and Wildlife Service (CDFW)
END	State listed as Endangered
THR	State listed as Threatened
SSC	California Species of Special Concern
FP	Fully Protected Species
WL	Watch List

Special-Status Wildlife Species Present

The following species were observed on the site during the reconnaissance survey:

- Northern harrier is a CDFW SSC. This species is typically found in open habitats with dense ground cover including grasslands, agricultural fields, and marshes. Northern harriers nest on the ground, preferring wetland habitat for cover. One adult was observed scanning the landscape of the Project Area during the habitat assessment in 2020.
- Burrowing owl is a USFWS BCC, a CDFW SSC, and Imperial County species of conservation focus. It is typically found in dry open areas with few trees and short grasses; it is also found in vacant lots near human habitation. It uses uninhabited mammal burrows for roosts and nests, often in close proximity to California ground squirrel colonies. It primarily feeds on large insects and small mammals but will also eat birds and amphibians. Three burrowing owls were observed flushing from/to their burrows; two within the southern portion of the Project Area and one from a rubble pile of the northern portion of the Project Area in 2020 (Figure 5). One within the southern portion of the Project Area was occupying a burrow along the berm of the access road.

- Black-tailed gnatcatcher is a CDFW WL species. This species remains in pairs all year, defending permanent territories. Black-tailed gnatcatchers prefer dry washes or desert brush with varied growth of mesquite, acacias, and paloverdes, but are also known to inhabit tamarisk scrub. A pair of black-tailed gnatcatchers was observed foraging and calling within the tamarisk thicket to the west within the buffer of the Project Area in 2020. This species was observed again within the same area in 2022 (Figure 5).
- Yellow warbler is a USFWS BBC and CDFW SCC. This species prefers scrub and woodlands, particularly along waterways and wetlands. Typically, yellow warblers nest in willows, alders, and cottonwoods, but have been observed nesting in tamarisk thickets. Several adults were observed foraging in the tamarisk thicket within the buffer to the northwest of the Project Area in 2020 (Figure 5).
- Loggerhead shrike is a USFWS BCC and CDFW SSC. This species prefers open country with scattered shrubs and trees. They frequent agricultural fields, abandoned orchards, desert scrublands, and riparian areas. One individual was observed perching in the tamarisk thickets in the western section of the Project Area in 2020. An individual was also observed perched within the creosote bush scrub habitat to the north of the access road in 2022.

Special-Status Wildlife Species with a High Potential to Occur

Two species were found to have high potential to occur within the Project Area due to the presence of suitable habitat for the species on the site and because a known occurrence has been recorded within five miles of the site:

- Flat-tailed horned lizard (*Phrynosoma mcallii*) is a CDFW SSC and Imperial County Species of conservation focus. This species is most commonly found on sandy flats and valleys within desert scrub habitat with little or no windblown sand. They can also be found on salt flats and gravelly soils. The creosote bush scrub and salt flat habitats provide suitable habitat for the flat-tailed horned lizard. Four recent CNDDDB records occur within five miles of the Project Area. The closest recorded occurrence is less than one mile north of the site from 2014.
- Yuma hispid cotton rat (*Sigmodon hispidus eremicus*) is a CDFW SSC. This species is generally associated with mesic habitats near drainage ditches, streams, and sloughs but also occurs in open fields or on the borders of open fields where there is dense grass habitat or agricultural fields. There is potential for this species to occur near the All-American Canal and nearby dense arrow weed thicket and tamarisk thicket habitats. Two recent CNDDDB records occur less than one mile north of the access road for the site. This species was found in arrow weed scrub and freshwater marsh adjacent to the All-American Canal in 2007.

ECORP: N:\2020\2020-142 Cedar 1 Solar\MAPS\Biological Resources\Vega_4_Access_Road_SSS_Observation_V2.mxd (TR)-rotellini 7/6/2022



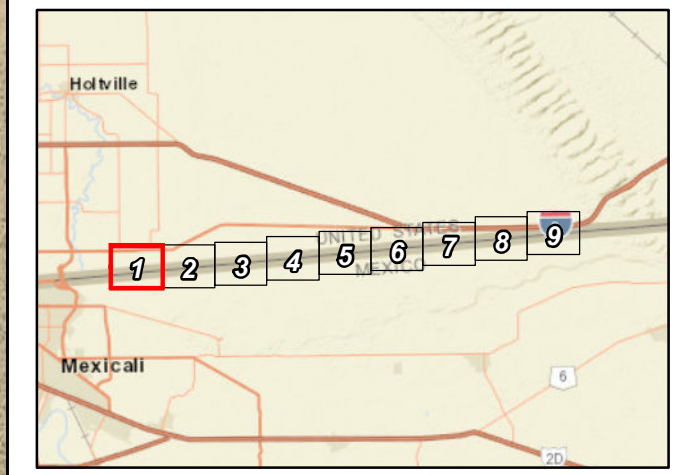
Map Features

- Vega 4 Project Area - 440.802
- 500' Buffer

Special-status Species Observations

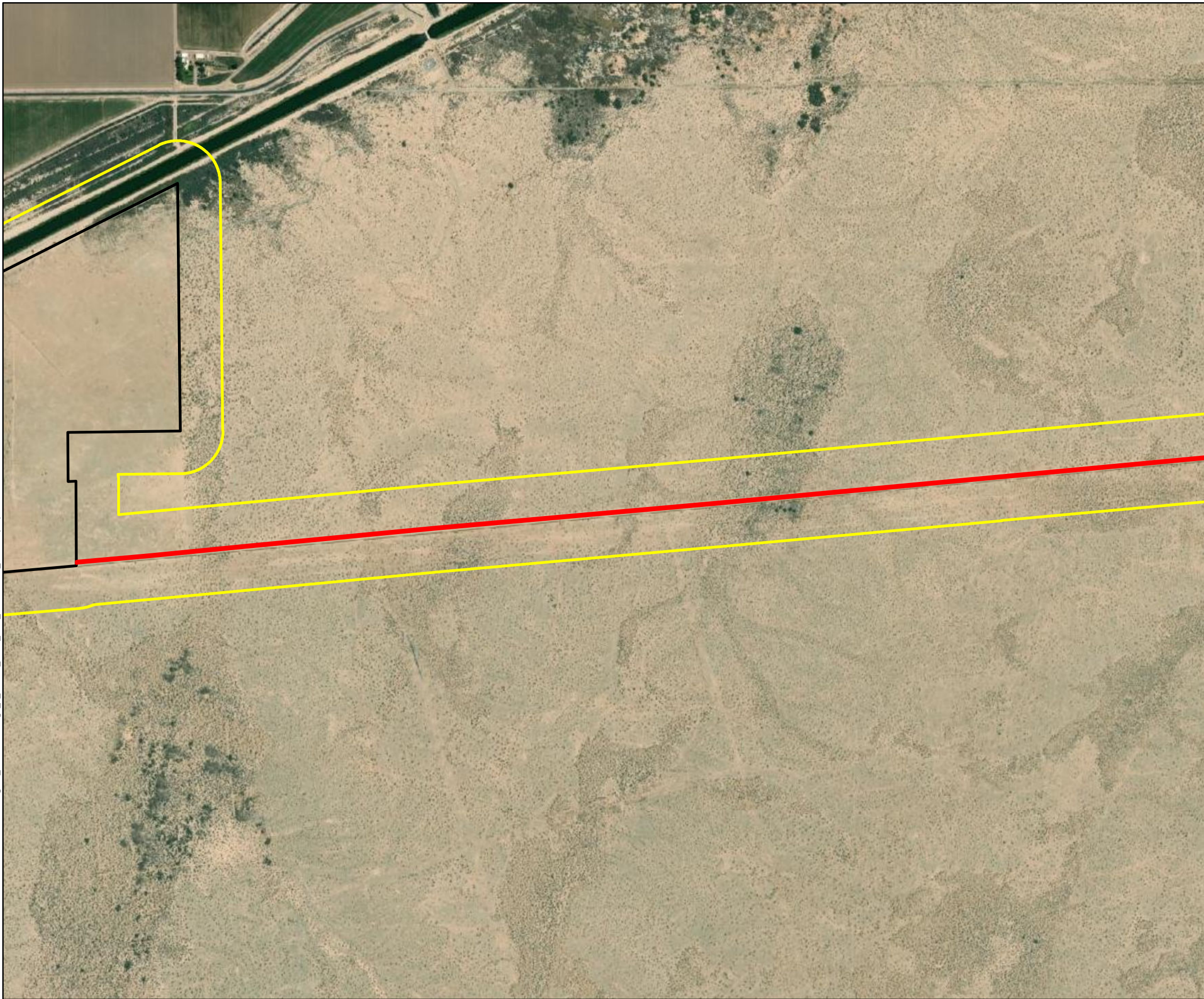
- Black-tailed gnatcatcher (*Poliptila melanura*)
- Burrowing owl (*Athene cunicularia*)
- Loggerhead shrike (*Lanius ludovicianus*)
- Yellow warbler (*Setophaga petechia*)

Service Layer Credits: Sources: Esri, HERE, Garmin, USGS, Intermap, INCREMENT P, NRCan, Esri Japan, METI, Esri China (Hong Kong), Esri Korea, Esri (Thailand), NGCC, (c) OpenStreetMap contributors, and the GIS User Community






Map Date: 7/6/2022

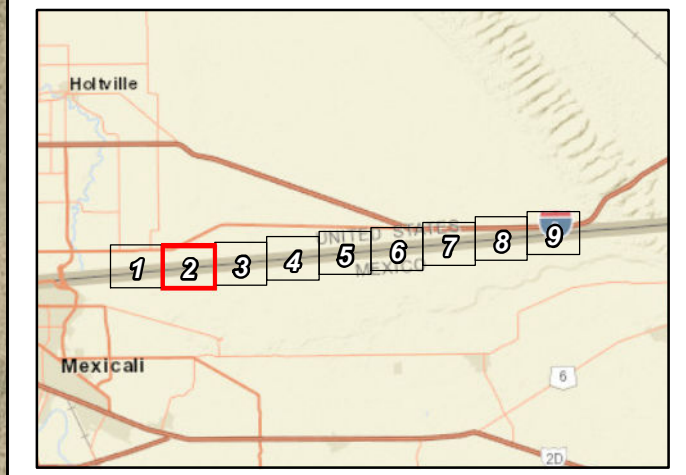
ECORP: N:\2020\2020-142 Cedar 1 Solar\MAPS\Biological_Resources\Vega_4_Access_Road_SSS_Observation_V2.mxd (TR)-rotellini 7/6/2022



Map Features

-  Vega 4 Project Area - 440.802
-  Access Road - 69.735 ac.
-  500' Buffer

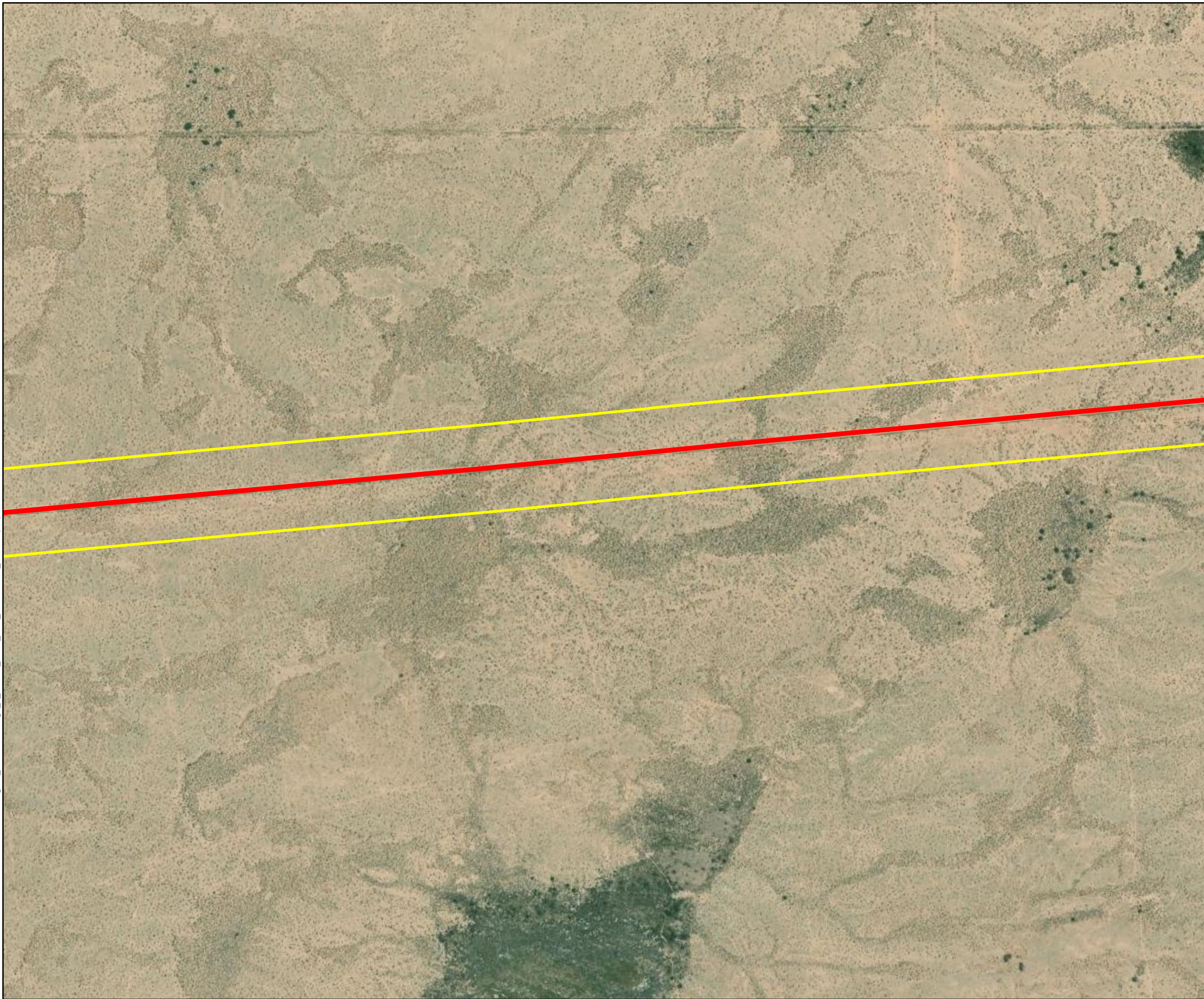
Service Layer Credits: Sources: Esri, HERE, Garmin, USGS, Intermap, INCREMENT P, NRCan, Esri Japan, METI, Esri China (Hong Kong), Esri Korea, Esri (Thailand), NGCC, (c) OpenStreetMap contributors, and the GIS User Community





Map Date: 7/6/2022



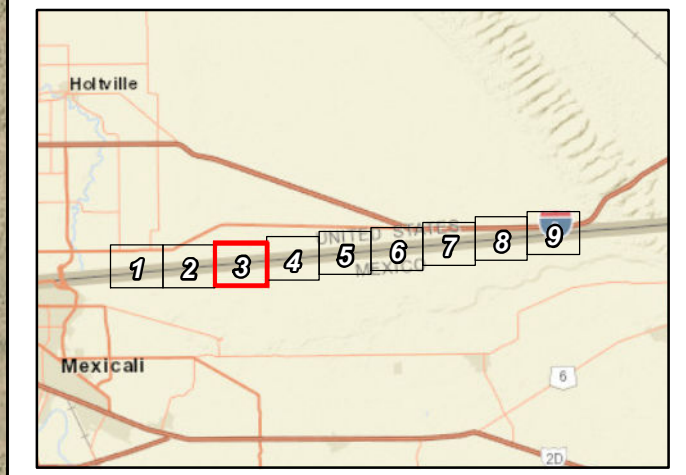
ECORP: N:\2020\2020-142 Cedar 1 Solar\MAPS\Biological_Resources\Vega_4_Access_Road_SSS_Observation_V2.mxd (TR)-rotellini 7/6/2022



Map Features

-  Access Road - 69.735 ac.
-  500' Buffer

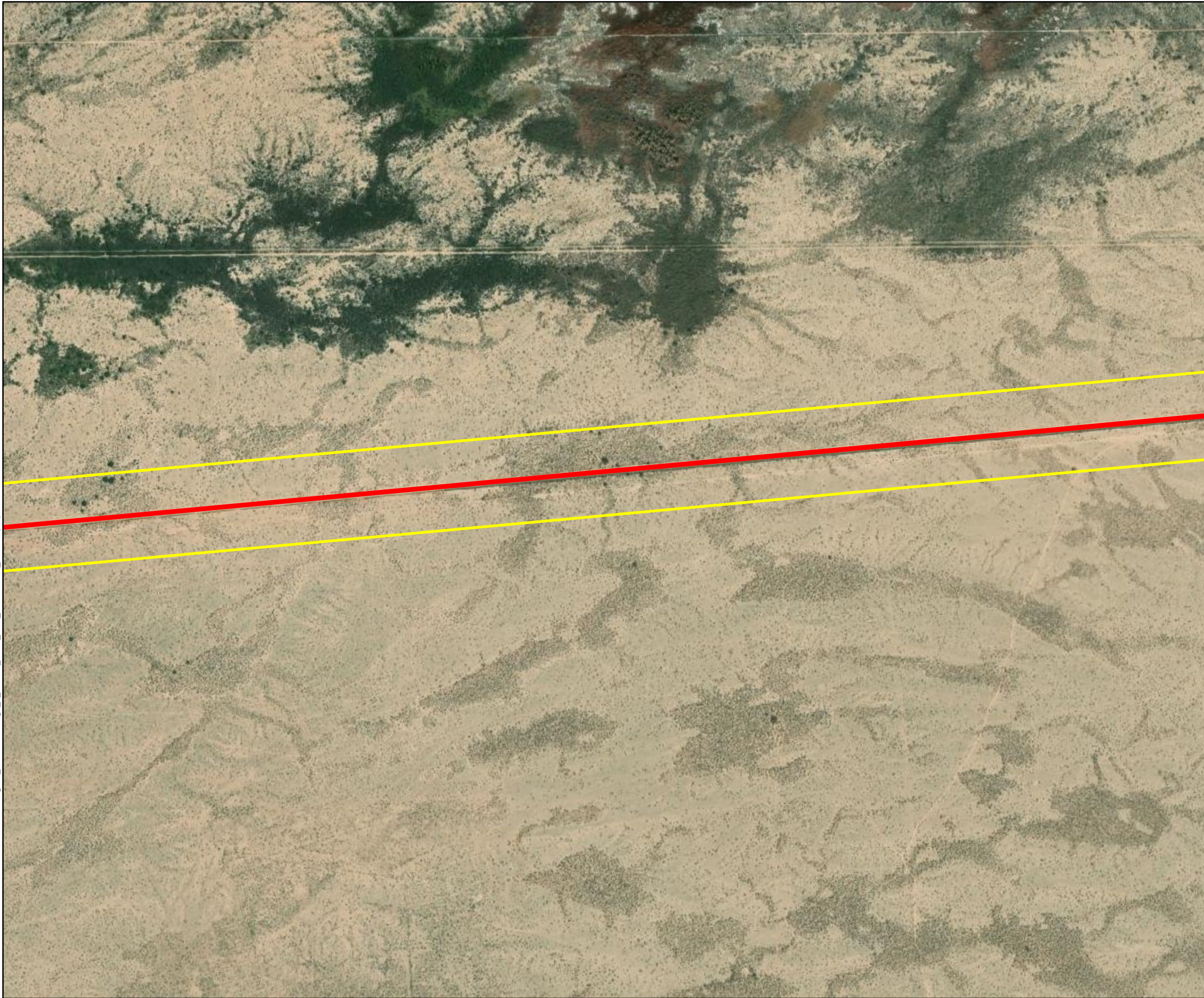
Service Layer Credits: Sources: Esri, HERE, Garmin, USGS, Intermap, INCREMENT P, NRCan, Esri Japan, METI, Esri China (Hong Kong), Esri Korea, Esri (Thailand), NGCC, (c) OpenStreetMap contributors, and the GIS User Community





Map Date: 7/6/2022



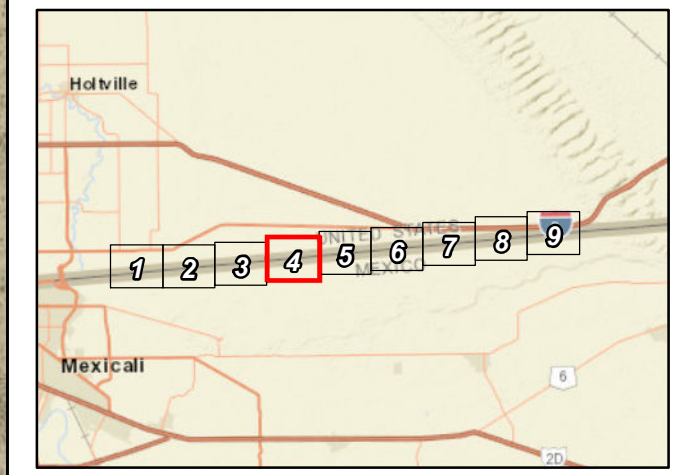
ECORP: N:\2020\2020-142 Cedar 1 Solar\MAPS\Biological_Resources\Vega_4_Access_Road_SSS_Observation_V2.mxd (TR)-rpt\lilini 7/6/2022



Map Features

-  Access Road - 69.735 ac.
-  500' Buffer

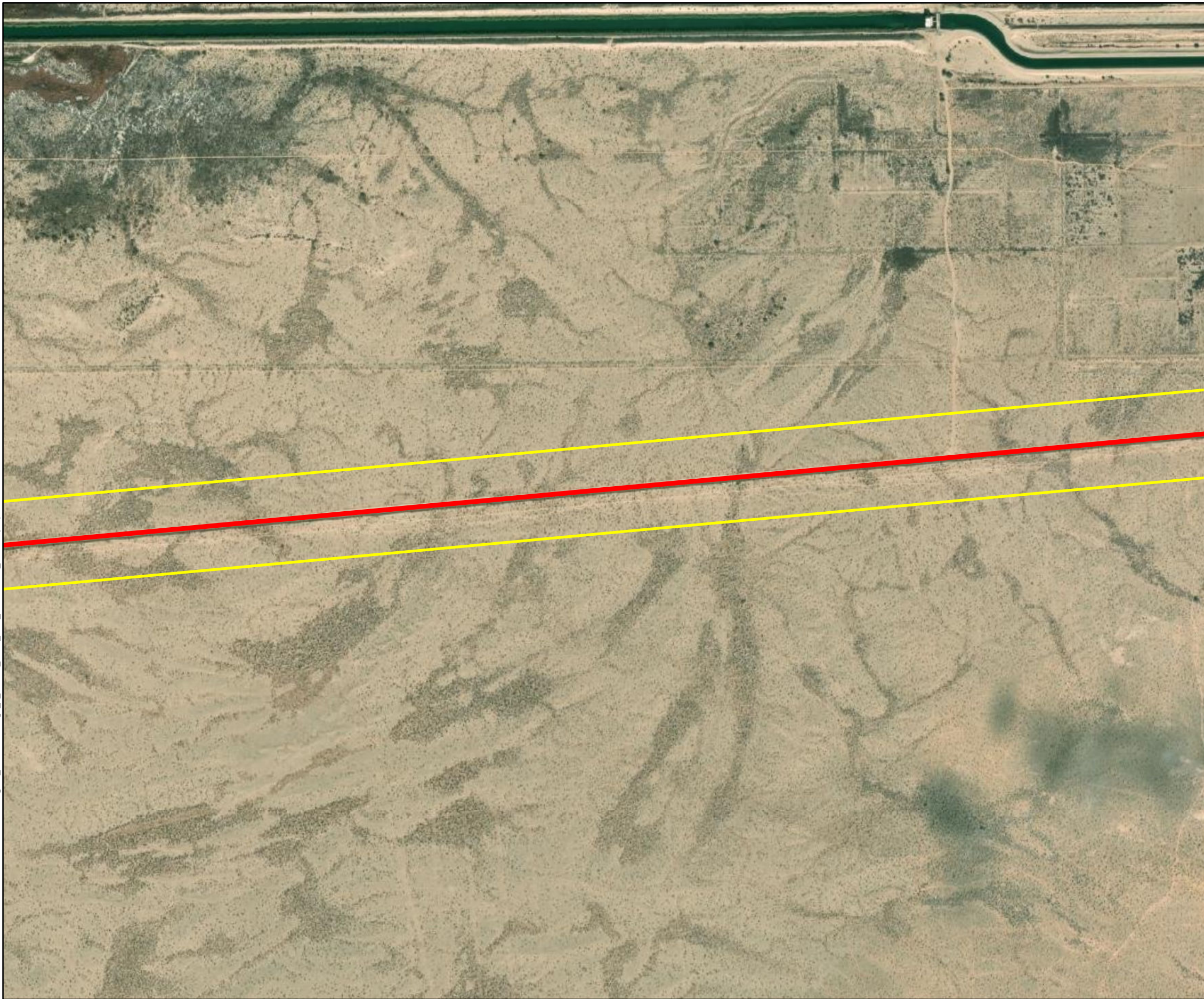
Service Layer Credits: Sources: Esri, HERE, Garmin, USGS, Intermap, INCREMENT P, NRCan, Esri Japan, METI, Esri China (Hong Kong), Esri Korea, Esri (Thailand), NGCC, (c) OpenStreetMap contributors, and the GIS User Community





Map Date: 7/6/2022



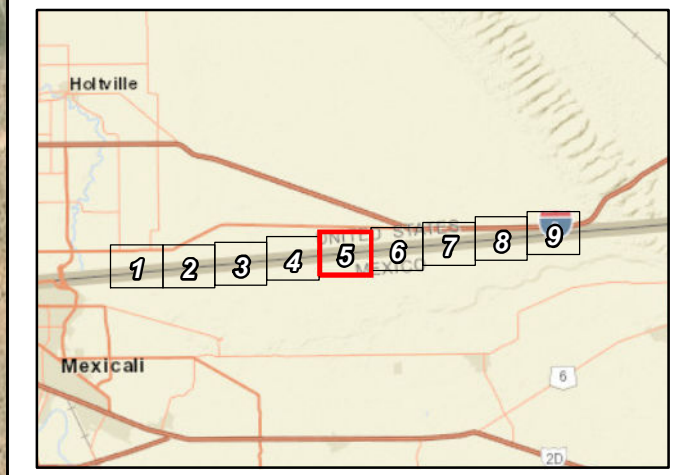
ECORP: N:\2020\2020-142 Cedar 1 Solar\MAPS\Biological_Resources\Vega_4_Access_Road_SSS_Observation_V2.mxd (TR)-rpt\lml 7/6/2022



Map Features

-  Access Road - 69.735 ac.
-  500' Buffer

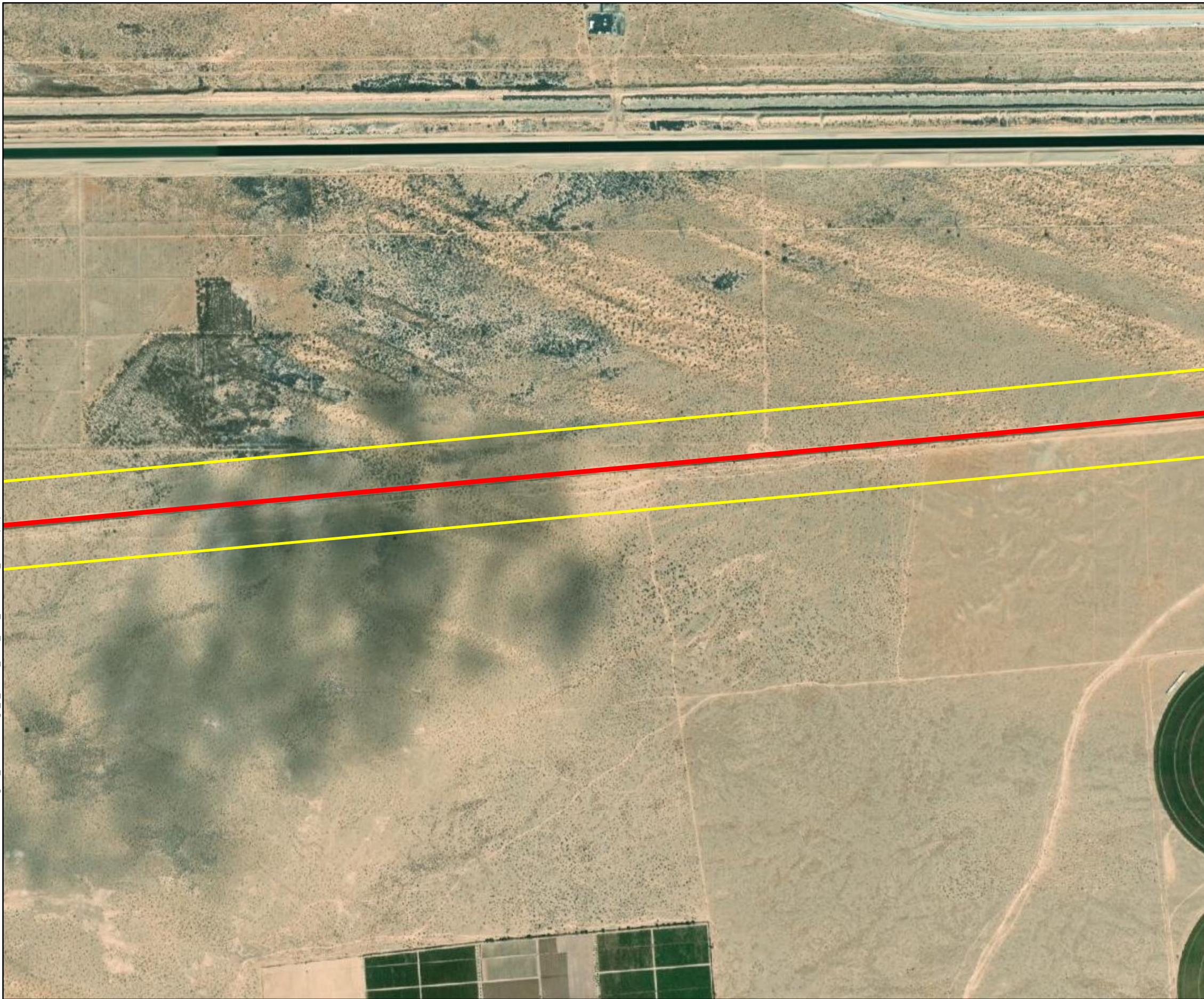
Service Layer Credits: Sources: Esri, HERE, Garmin, USGS, Intermap, INCREMENT P, NRCan, Esri Japan, METI, Esri China (Hong Kong), Esri Korea, Esri (Thailand), NGCC, (c) OpenStreetMap contributors, and the GIS User Community



Map Date: 7/6/2022



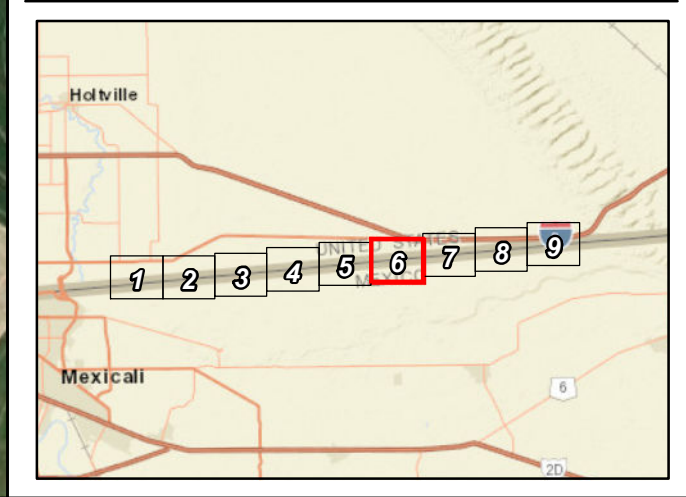
ECORP: N:\2020\2020-142_Cedar_1_Solar\MAPS\Biological_Resources\Vega_4_Access_Road_SSS_Observation_V2.mxd (TR)-rotelini 7/6/2022



Map Features

- Access Road - 69.735 ac.
- 500' Buffer

Service Layer Credits: Sources: Esri, HERE, Garmin, USGS, Intermap, INCREMENT P, NRCan, Esri Japan, METI, Esri China (Hong Kong), Esri Korea, Esri (Thailand), NGCC, (c) OpenStreetMap contributors, and the GIS User Community



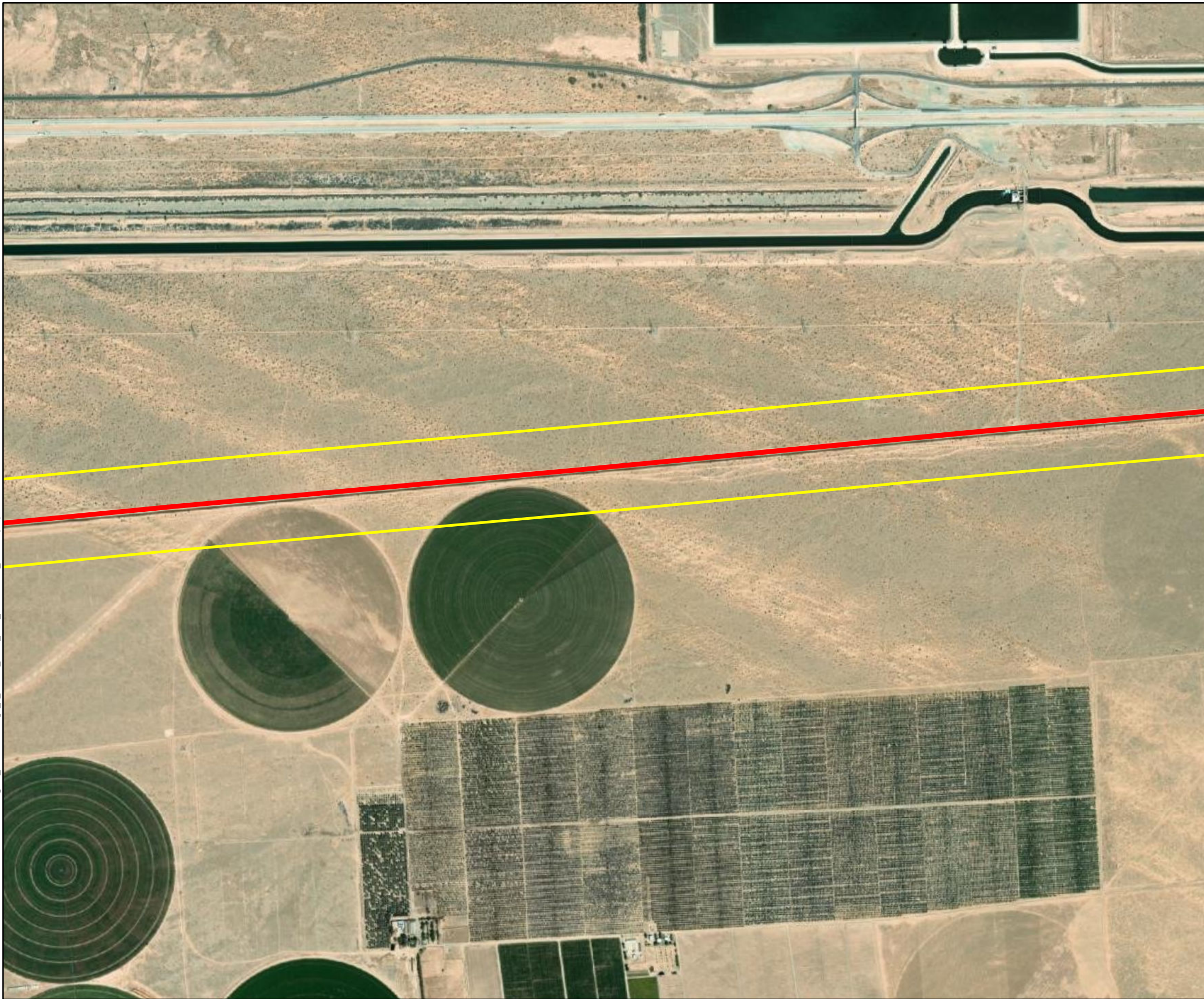
Map Date: 7/6/2022





PC ORIGINAL PKG

Figure 5. Special-status Species Observations
Sheet 6 of 9
2020-142 Vega SES 4

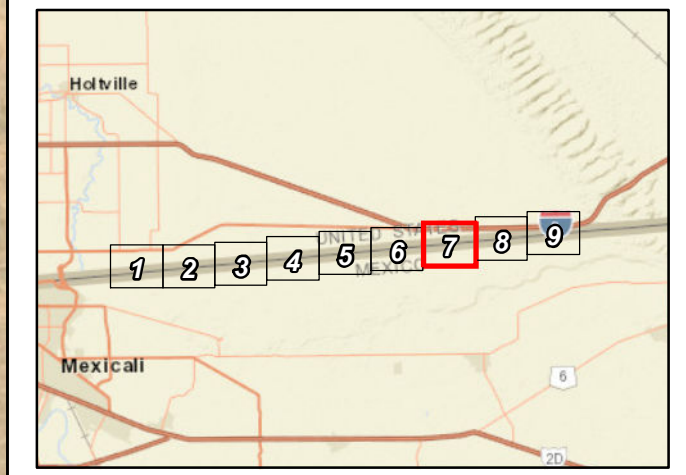
ECORP: N:\2020\2020-142 Cedar 1 Solar\MAPS\Biological_Resources\Access_Road_SSS_Observation_V2.mxd (TR)-rotellini 7/6/2022



Map Features

-  Access Road - 69.735 ac.
-  500' Buffer

Service Layer Credits: Sources: Esri, HERE, Garmin, USGS, Intermap, INCREMENT P, NRCan, Esri Japan, METI, Esri China (Hong Kong), Esri Korea, Esri (Thailand), NGCC, (c) OpenStreetMap contributors, and the GIS User Community





Map Date: 7/6/2022



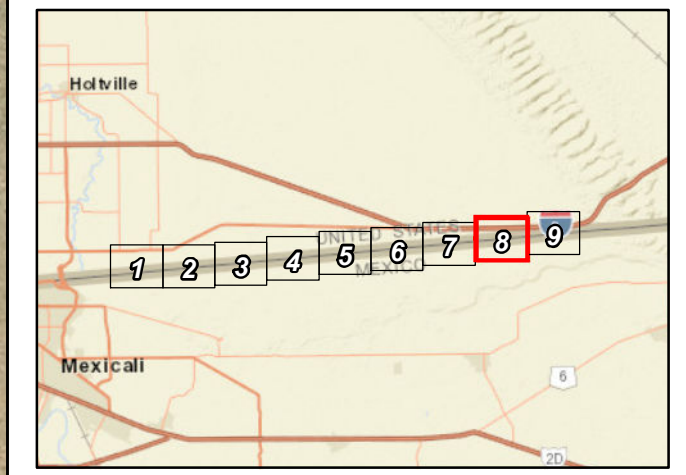
ECORP: N:\2020\2020-142_Cedar_1_Solar\MAPS\Biological_Resources\Vega_4_Access_Road_SSS_Observation_V2.mxd (TR)-rotellini 7/6/2022



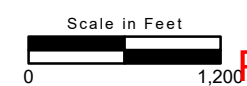
Map Features

-  Access Road - 69.735 ac.
-  500' Buffer

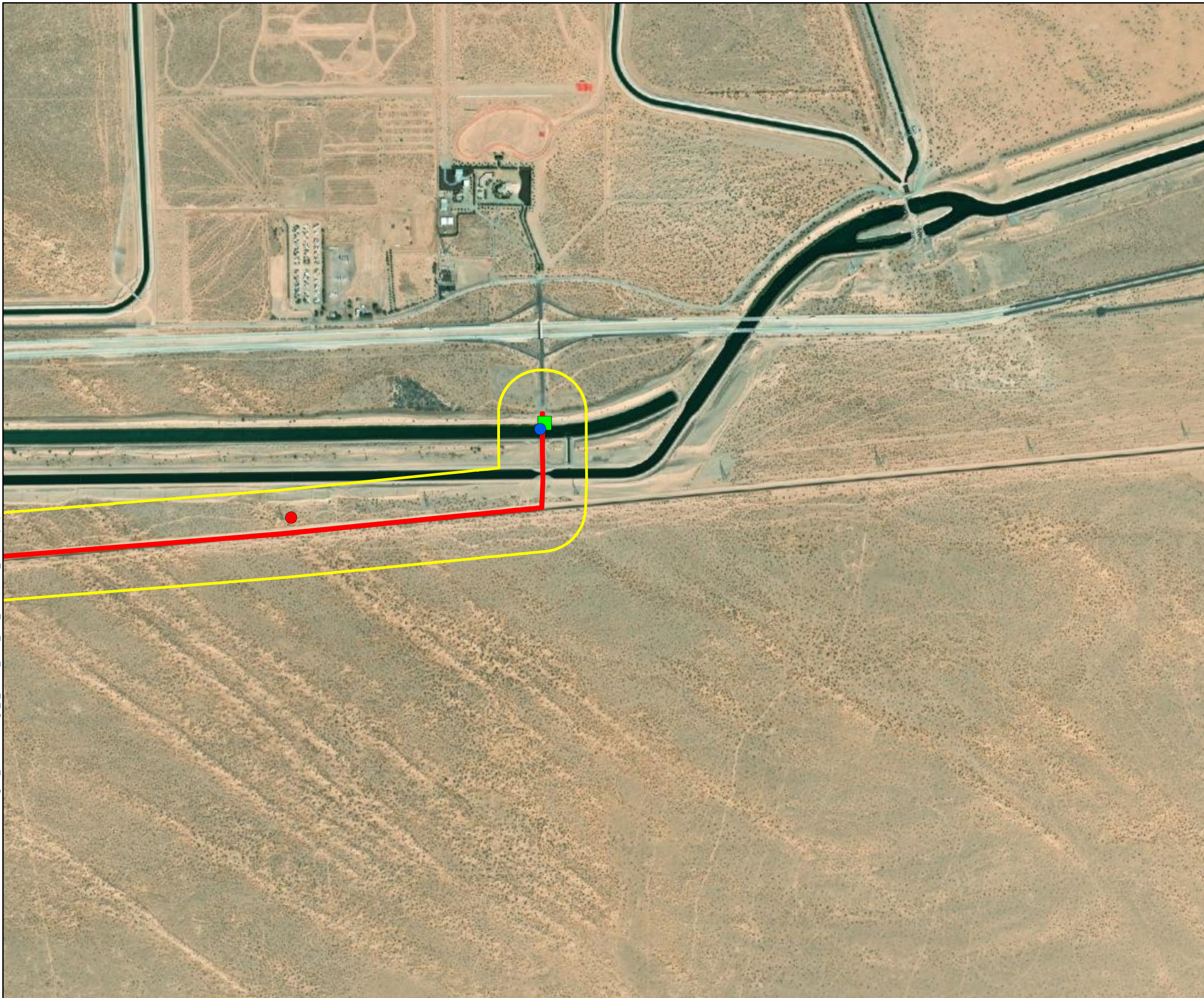
Service Layer Credits: Sources: Esri, HERE, Garmin, USGS, Intermap, INCREMENT P, NRCan, Esri Japan, METI, Esri China (Hong Kong), Esri Korea, Esri (Thailand), NGCC, (c) OpenStreetMap contributors, and the GIS User Community



Map Date: 7/6/2022



ECORP: N:\2020\2020-142_Cedar_1_Solar\MAPS\Biological_Resources\Vega_4_Access_Road_SSS_Observation_V2.mxd (TR)-rotellini 7/6/2022



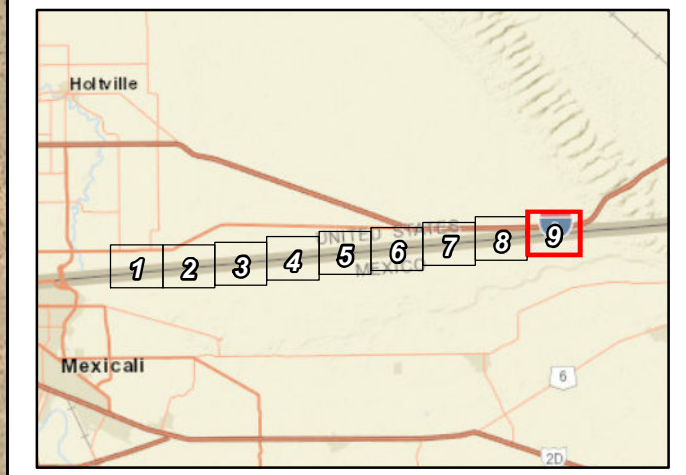
Map Features

- Access Road - 69.735 ac.
- 500' Buffer

Special-status Species Observations

- Cliff swallow (*Petrochelidon pyrrhonota*) Nesting Site
- Loggerhead shrike (*Lanius ludovicianus*)
- Bat Roosting Site

Service Layer Credits: Sources: Esri, HERE, Garmin, USGS, Intermap, INCREMENT P, NRCan, Esri Japan, METI, Esri China (Hong Kong), Esri Korea, Esri (Thailand), NGCC, (c) OpenStreetMap contributors, and the GIS User Community



Map Date: 7/6/2022

Special-Status Wildlife Species with a Moderate Potential to Occur

Seven species were found to have moderate potential to occur within the Project Area because habitat (including soils and elevation factors) for the species occurs on the site and a known occurrence exists within the database search, but not within five miles of the site; or a known occurrence exists within five miles of the site and marginal or limited amounts of habitat occurs within the Project Area:

- Yuma Ridgway's rail (*Rallus obsoletus yumanensis*) is a federally listed endangered and state-listed threatened species. The Yuma Ridgway's rail prefers freshwater marshes composed of cattails and bulrushes. There is suitable habitat for this species within the wetlands nestled within the tamarisk and arrow weed scrub.
- California horned lark (*Eremophila alpestris ssp. actia*) is a CDFW WL species. It occurs in bare, open areas dominated by low vegetation or widely scattered shrubs, including prairies, deserts, and plowed fields. It nests in a hollow on the ground. The disturbed creosote scrub habitat onsite and in the buffer zones provides potential habitat. No CNDDDB records occur within five miles of the Project Area.
- Yellow-breasted chat (*Icteria virens*) is a CDFW SSC. This species is commonly found in shrublands along rivers. There is potential for the yellow-breasted chat to occur within the arrow weed and tamarisk scrub in the eastern portion of the Project Area.
- Pallid bat (*Antrozous pallidus*) is a CDFW SSC. This species is commonly found in desert habitat and is known to roost in bridges. Potential roosting habitat for this species is present within the within the Gordon Wells Road bridge that crosses over the offline storage canal, north of the All-American Canal.
- Townsend's big-eared bat (*Corynorhinus townsendii*) is a CDFW SSC. The Project Area is within the known range of this species and this species is known to roost in bridges. Potential roosting habitat for this species is present within the within the Gordon Road Wells bridge that crosses over the offline storage canal, north of the All-American Canal.
- Western yellow bat (*Lasiurus xanthinus*) is a CDFW SSC. This species is commonly found in desert habitat and is known to roost in the skirts of untrimmed palm trees. Potential roosting habitat for this species is present within the palm trees of the northeastern portion of the Project Area.
- Arizona myotis (*Myotis occultus*) is a CDFW SSC. The Project Area is within the known range of this species and this species is known to roost in bridges. Potential roosting habitat for this species is present within the Gordon Wells Road bridge that crosses over the offline storage canal, north of the All-American Canal.

Wildlife Species with Low Potential to Occur

Three species were found to have a low potential to occur within the Project Area because limited habitat for the species occurs on the site and a known occurrence has been reported in the database, but not

within five miles of the site, or suitable habitat strongly associated with the species occurs on the site, but no records were found in the database search:

- southwestern willow flycatcher (*Empidonax traillii* ssp. *extimus*), federally listed endangered and state-listed endangered ,
- Sonoran desert toad (*Incilius alvarius*), CDFW SSC, and
- red-diamond rattlesnake (*Crotalus ruber*), CDFW SSC.

Wildlife Species Presumed Absent

The following three species are presumed absent from the Project Area due to the lack of suitable habitat on the site:

- Gila woodpecker (*Melanerpes uropygialis*), USFWS BCC and CDFW END,
- western mastiff bat (*Eumops perotis* ssp. *californicus*), CDFW SSC, and
- big free-tailed bat (*Nyctinomops macrotis*), CDFW SSC.

4.4 Jurisdictional Aquatic Resources Assessment

An aquatic resources delineation was conducted by ECORP biologists during a separate survey effort, the results of which are presented under separate cover (ECORP 2022).

4.5 Wildlife Movement Corridors, Linkages, and Significant Ecological Areas

The concept of habitat corridors addresses the linkage between large blocks of habitat that allow the safe movement of mammals and other wildlife species from one habitat area to another. The definition of a corridor is varied, but corridors may include such areas as greenbelts, refuge systems, underpasses, and biogeographic land bridges, for example. In general, a corridor is described as a linear habitat, embedded in a dissimilar matrix, which connects two or more large blocks of habitat. Wildlife movement corridors are critical for the survivorship of ecological systems for several reasons. Corridors can connect water, food, and cover sources, spatially linking these three resources with wildlife in different areas. In addition, wildlife movement between habitat areas provides for the potential of genetic exchange between wildlife species populations, thereby maintaining genetic variability and adaptability to maximize the success of wildlife responses to changing environmental conditions. This is especially critical for small populations subject to loss of variability from genetic drift and effects of inbreeding. Naturally, the nature of corridor use and wildlife movement patterns varies greatly among species.

The Project Area was assessed for its ability to function as a wildlife corridor. The Project Area has an extensive riparian corridor in the western corner of the site that provides cover for migrating and nesting birds. It also provides foraging habitat for raptors and small and large mammals, including rodents and canids. The desert washes located within the western corner of the Project boundaries are likely utilized by wildlife moving through the area; therefore, these features and associated riparian habitat would be considered necessary linkages between conserved natural habitat areas or critical for wildlife movement because of the nearby direct connectivity to wetlands to the south of the Project Area. The northern and

southern boundaries are restricted by the All-American Canal to the north and the U.S./Mexico border wall borders the southern buffer of the Project Area. Although the border wall inhibits large mammal movement, avian species and small mammals may fly over or cross through the wall.

The disturbed creosote bush scrub portion of the Project is sparse with low plant diversity, and therefore offers little shelter and foraging habitat. The Project Area is open with barriers to the north and south, leaving the terrain accessibility constrained for ground-truthing wildlife. The Project borders the western edge of expansive agricultural fields and is surrounded to the north, west, and south by agriculture. Thus, the creosote scrub habitat only currently provides wildlife movement opportunities to the east because it consists of open and relatively unimpeded land. In conclusion, the creosote bush scrub habitat portion of the Project would not be considered a wildlife movement corridor that would need to be preserved to allow wildlife to move between important natural habitat areas due to the lack of conserved natural lands in the vicinity and the Project's proximity to farming lands. The creosote bush scrub habitat within the Project boundaries is exposed and does not contain any major features that would be considered critical movement corridors for wildlife. Therefore, the creosote bush habitat acts as more of a buffer between agricultural lands and wildlands to the east, but not as a corridor for wildlife.

5.0 IMPACT ASSESSMENT

Implementation of the Project has potential to impact creosote bush scrub, disturbed arrow weed thickets, disturbed creosote-white bursage scrub, and tamarisk thickets. These communities may provide suitable nesting and foraging habitat for passerines, including Yuma's Ridgway rail, burrowing owl, yellow warbler, loggerhead shrike, black-tailed gnatcatcher, raptor foraging habitat, and rare plant habitat. Conceptual design of the Project has not been finalized; therefore, impacts and minimization measures cannot be confirmed at this time. The following recommendations would be required to determine if the Project would result in significant impacts to vegetation communities, special-status plant and wildlife species, jurisdictional waters, and wildlife movement corridors.

5.1.1 *Special-Status Species*

Special-Status Plants

The literature review identified 14 special-status plant species that have the potential to occur within the Project Area. However, 11 of these plant species have a low potential to occur due to the limited suitable habitat within the Project Area. These species include Watson's's amaranth, Peirson's milk-vetch, gravel milk-vetch, Algodones Dunes sunflower, California satintail, ribbed cryptantha, winged cryptantha, hairy stickleaf, Darlington's blazing star, slender cottonheads, and giant Spanish-needle.

There is moderate potential for three rare plant species, Abram's spurge (CRPR 2B.2), Wiggins' croton (CRPR 2B.2), and sand food (CRPR 1B.2), to be present within the Project Area. Suitable habitat for this species is present within the creosote bush scrub and disturbed creosote bush – white bursage scrub habitats. Impacts that may occur to the species includes loss of individuals, habitat, and seedbank. Depending on the size of the population, this impact may be significant. Implementation of BIO-1 and BIO-2 is recommended to reduce impacts to a less than significant level.

Special-Status Wildlife

The literature review identified 21 special-status wildlife species that have the potential to occur within the Project Area. However, six of these species have a low or no potential to occur due to the lack of suitable and/or limited habitat within the Project Area. Wildlife species that are presumed absent from the Project Area include Gila woodpecker, western mastiff bat, and big free-tailed bat. Wildlife species with a low potential to occur include Sonoran Desert toad, red-diamond rattlesnake, and southwestern willow flycatcher.

Five special-status wildlife species were observed on site during the habitat assessment. Black-tailed gnatcatcher, northern harrier, yellow warbler, and loggerhead shrike were observed in the tamarisk and arrow weed thickets in the western portion of the Project Area and buffer. Burrowing owl and their burrows were observed within the disturbed creosote-white bursage scrub in the western portion of the Project Area, within a berm adjacent to the access road, and in a concrete pile in the northeastern corner of the site. Direct impacts to these species that could occur include injury, mortality, nest failures, and loss of young. Indirect impacts include loss of nesting and foraging habitat, increase in anthropogenic effects (i.e., noise levels, introduction of invasive/nonnative species, increase in human activity, increase in dust). Impacts to these species could be considered significant; therefore, implementation of BIO-2, BIO-3, BIO-4, BIO-5, and BIO-7 is recommended.

Foraging habitat for a number of raptor species and breeding habitat for numerous passerine species that are protected by the MBTA occurs throughout the Project Area. The site provides nesting habitat for ground-nesting species as well as species that nest in riparian scrub habitat. Due to the lack of large trees within the Survey Area, there is no suitable nesting habitat for raptor species. However, northern harriers are ground nesters; therefore, the tamarisk thicket and disturbed arrow weed thicket habitats provide potential nesting habitat for this species. Direct impacts to nesting avian species include injury, mortality, loss of young, and nest failure. Indirect impacts include loss of foraging and nesting habitat for passerine and raptors species, increase in noise and human activities, and potential introduction of invasive/nonnative species. Implementation of BIO-4, BIO-5, and BIO-7 are recommended to mitigate for potential impacts.

The palm trees located within the Project Area may provide roosting habitats for bat species, particularly western yellow bat, a SSC species. These trees could function as maternity roost sites for this species. During the 2022 assessment of the access road, a bat roost was observed within the bridge at Gordon Wells Road that crosses the offline storage canal, north of the All-American Canal. Bat species in California are protected by Section 4150 (protection of non-game mammals from take) of the California Fish and Game Code. Section 4150 of the California Fish and Game Code prohibits the take of any naturally occurring mammals in California that are nongame mammals, which includes all species of the Order Chiroptera (bats). Based on the quantity of bats within the bridge and the timing of the observation of the colony, there is high likelihood that this is a maternity roost. The Gordon Wells Road bridge will be used for access to the solar field portion of the Project Area and no direct impacts are expected to occur to the bridge. There may be indirect impacts to the roost through noise and vibration, due to a temporary increase in traffic above the bridge. However, because the bridge currently functions as an active roadway, the colony would be expected to be accustomed to noise and vibrations associated with traffic and

indirect impacts would not be expected to be significant. The main Project Area is located approximately 22 miles west of the bridge and work is expected to occur within a 12-month period. An increase in truck traffic over the bridge to facilitate construction of the Project is not expected to have a significant impact on the bat colony and will be temporary in nature. Once completed, the bridge directly northeast of the Project (near where the East Highline Canal intersects the All-American Canal) will be used for site access instead of the Gordon Wells Road bridge. The bridge directly northeast of the Project is frequently used by U.S. Border Patrol and IID and was not assessed for bat occupation due to it being outside of the Project Area.

The Gordon Wells Road bridge and 22-mile access road will be used during the construction phase of the Project due to the use of heavier equipment. Bat acoustic surveys and monitoring should be implemented to determine if sensitive bat species occur within the Gordon Road Wells bridge or palm trees (if planned for removal). All bat species with potential for occurrence for the Project are SSC species and Project-related impacts to bat species and bat maternity roosts are potentially significant. Impacts to bat species are expected to be temporary in nature and individual bats are expected to be able to vacate the trees that are removed during construction without being subject to harm if a two-step palm tree removal process is conducted. The two-step removal process for palm trees involves the following:

- The uppermost live fronds (the top of the tree) should be removed entirely on the first day along with the upper 25 percent of the frond skirt. This method would allow for sufficient disturbance of the tree that would encourage any roosting bats within the frond skirt to abandon the tree during evening emergence without directly impacting roosting bats within the skirt. The remainder of the tree should be removed the following day.
- If bats emerge at any time during the tree trimming, trimming activities should cease at that individual tree for the remainder of the day to allow for any additional bats roosting in the tree to emerge during evening hours when it is safe and appropriate for them to do so. Trimming of the tree may resume the following morning.
- Tree trimming activities in the fall should be conducted on days when weather conditions are such that roosting bats are unlikely to be in torpor (predicted overnight lows on evenings before and after the tree trimming activities are above 45 degrees Fahrenheit) to the extent practicable.

Implementation of BIO-9 would reduce impacts to bat species and maternity roosts to a less than significant level.

5.1.2 Sensitive Natural Communities

The ±511-acre Project Area and accompanying access road is comprised of disturbed creosote-white bursage scrub, creosote bush scrub, disturbed arrow weed thickets, tamarisk thickets, and urban/developed land, which would be directly impacted by the Project. Active agriculture, fallow agriculture, disturbed creosote bush scrub, and creosote bush – white bursage scrub occur within the Project buffer area. In-kind mitigation, up to 3:1 ratio, may be required by CDFW to offset impacts to disturbed arrow weed thickets and tamarisk thickets in order to reduce impacts to a less than significant level.

Implementation of BIO-7 is recommended to reduce potential impacts.

5.1.3 State- and/or Federally Protected Wetlands and Waters

The results of the Aquatic Resources Delineation and discussion of potential impacts on State or federally protected wetlands or Waters of the U.S. are discussed in the Aquatic Resources Delineation Report (ECORP 2022), prepared under separate cover. Implementation of BIO-6 is recommended to mitigate for potential significant impacts.

5.1.4 Wildlife Corridors and Nursery Sites

The Project Area is located adjacent to areas containing existing disturbances (i.e., roads, border wall, and active agricultural land). The majority of the site does not contain suitable vegetation and/or cover to support wildlife movement and is nestled on the edge of agricultural and development; therefore, wildlife movement opportunities connecting the Project Area to large, undeveloped natural areas is extremely limited. However, the riparian habitat could act as a potential corridor and nursery site for migrating wildlife species. Therefore, implementation of BIO-2, BIO-4, BIO-5, BIO-6, and BIO-7 are recommended to mitigate for potential significant impacts.

5.1.5 Habitat and Conservation Plans and Natural Community Conservation

There is no Imperial County Plan or local plan at the time of this report; therefore, consultation with USFWS and CDFW would be required should listed plant and/or wildlife species be found to occur.

6.0 RECOMMENDATIONS AND MITIGATION MEASURES

The following recommendations have been developed in accordance with the CEQA impacts analysis for the Project (see Section 5) but should not be considered mitigation measures at this point in the Project planning process. These actions are recommended prior to Project implementation:

BIO-1 Rare Plant Surveys: Rare plant surveys should be conducted within suitable habitat within the Project Area during the appropriate blooming period for the Abrams' spurge (approximately September through November), Wiggins' croton (approximately March through May), and sand food (approximately April through June). The surveys should be conducted by a botanist or qualified biologist in accordance with the USFWS Guidelines for Conducting and Reporting Botanical Inventories for Federally Listed, Proposed, and Candidate Plants (USFWS 1996); the CDFW Protocols for Surveying and Evaluating Impacts to Special Status Native Plant Populations and Sensitive Natural Communities (CDFW 2018); and the CNPS Botanical Survey Guidelines (CNPS 2001). If any special-status species are observed during the rare plant surveys, the location of the individual plant or population will be recorded with a submeter GPS device for mapping purposes. If Project-related impacts to rare plants within the Project Area are unavoidable, then consultation with CDFW may be required to develop a mitigation plan or additional avoidance and minimization measures. Mitigation measures that may be implemented if the species is observed include establishing a no-disturbance buffer around locations of individuals or a population, salvage or seed collection, and additional monitoring requirements.

BIO-2 Biological Monitoring: A qualified biologist should be present to monitor all ground-disturbing and vegetation-clearing activities conducted for the Project. During each monitoring day, the biological

monitor should perform clearance survey “sweeps” at the start of each work day that vegetation clearing takes place to minimize impacts on special-status species with potential to occur (including, but not limited to, special-status and/or nesting bird species and flat-tailed horned lizard). The monitor will be responsible for ensuring that impacts to special-status species, nesting birds, and active nests will be avoided to the greatest extent possible. Biological monitoring should take place until the Project Area has been completely cleared of any vegetation. If an active nest is identified, the biological monitor should establish an appropriate disturbance limit buffer around the nest using flagging or staking. Construction activities should not occur within any disturbance limit buffer zones until the nest is deemed no longer active by the biologist. If special-status wildlife species are detected during biological monitoring activities, then consultation with the USFWS and/or CDFW should be conducted and a mitigation plan should be developed to avoid and offset impacts to these species. Mitigation measures may consist of work restrictions or additional biological monitoring activities after ground-disturbing activities are complete.

BIO-3 Pre-Construction Surveys for Burrowing Owl: Pre-construction surveys for burrowing owl should be conducted within the Project Area and adjacent areas prior to the start of ground-disturbing activities. The surveys should follow the methods described in the CDFW's *Staff Report on Burrowing Owl Mitigation* (CDFG 2012). Two surveys should be conducted, with the first survey being conducted between 30 and 14 days before initial ground disturbance (grading, grubbing, and construction), and the second survey being conducted no more than 24 hours prior to initial ground disturbance. If burrowing owls and/or suitable burrowing owl burrows with sign (e.g., whitewash, pellets, feathers, prey remains) are identified within the Project Area during the survey and impacts to those features are unavoidable, consultation with the CDFW should be conducted and the methods described in the CDFW's *Staff Report on Burrowing Owl Mitigation* (CDFG 2012) for avoidance and/or passive relocation should be followed.

BIO-4 Pre-Construction Nesting Bird Survey: If construction or other Project activities are scheduled to occur during the bird breeding season (typically February 1 through August 31 for raptors and March 15 through August 31 for the majority of migratory bird species), a pre-construction nesting-bird survey should be conducted by a qualified avian biologist to ensure that active bird nests, including those for the black-tailed gnatcatcher, northern harrier, yellow warbler, burrowing owl, and loggerhead strike, will not be disturbed or destroyed. The survey should be completed no more than three days prior to initial ground disturbance. The nesting-bird survey should include the Project Area and adjacent areas where Project activities have the potential to affect active nests, either directly or indirectly due to construction activity or noise. If an active nest is identified, the biologist should establish an appropriately sized disturbance-limit buffer around the nest using flagging or staking. Construction activities should not occur within any disturbance-limit buffer zones until the nest is deemed inactive by the qualified biologist. If construction activities cease for a period of greater than three days during the bird breeding season, a pre-construction nesting bird survey should be conducted prior to the commencement of activities.

BIO-5 Pre-Construction Survey for Special-Status Species: A pre-construction survey should be conducted for special-status wildlife species within all areas of potential permanent and temporary disturbance. The pre-construction survey should take place no more than 14 days prior to the start of ground-disturbing activities. The pre-construction surveys should take place regardless of breeding

season timing and should focus on identifying the presence of special-status wildlife species present within the Project Area or that were identified as having a high potential to occur on the site. These species include, but are not limited to, flat-tailed horned lizard, burrowing owl, northern harrier, black-tailed gnatcatcher, and yellow warbler. Should any special-status species be identified during the pre-construction survey, consultation to develop suitable avoidance and minimization measures with the appropriate agency (USFWS, CDFW) may need to be undertaken.

BIO-6 Aquatic Resources Regulatory Permitting: If Project-related impacts occur to the riparian areas that may also fall under the jurisdiction of the USACE, CDFW, RWQCB a regulatory permit with those agencies is needed prior to the impact occurring. Refer to the ECORP Jurisdiction Delineation Report (2022) for preliminary determination of regulatory limits that areas that may be regulated by USACE, CDFW, or SWRCB. Permitting includes preparation and submittal of a Pre-Construction Notification under Section 404 of the federal CWA, an Application for Water Quality Certification under Section 401 of the federal CWA and a Notification of Lake or Streambed Alteration under Section 1600 of the California Fish and Game Code. Other items such as finalized project plans, quantities of fill material, supporting technical studies, etc., are also submitted along with the applications. As a part of this process, the project must also identify and approve mitigation through the respective agencies. Mitigation can include onsite or offsite options or could include payment of an in-lieu fee to a conservation organization. Types of mitigation can include restoration, creation, rehabilitation, enhancement, or other types of habitat improvement. Typically, the type of mitigation and acreage of mitigation is negotiated with the regulatory agencies during the permitting process.

BIO-7 Wetland/Riparian Habitat Avoidance: To the greatest extent possible, plans should avoid impacts to arrow weed thicket (disturbed) and tamarisk thicket habitats to minimize potential impacts to special-status species. Excluding these habitats from the Project should also minimize mitigation and permitting requirements to meet the less-than-significance threshold.

BIO-8 Minimization of Impacts to Wetland/Riparian Habitat: Solar panels, structures, and new access roads should not be placed within 50 feet of wetland and riparian habitat boundaries. A construction buffer of 300 feet should be established around the wetlands and riparian habitat during bird breeding season (February 1 – August 31). Prior to construction, fencing should be installed approximately 10 feet from the wetland and riparian habitat boundaries within 50 feet of the Project. Fencing should be easily visible to construction.

The following best management practices are not mitigation measures pursuant to CEQA but are recommended to further reduce impacts to special-status species that have potential to occur on the property:

- Confine all work activities to a pre-determined work area.
- To prevent inadvertent entrapment of wildlife during the construction phase of the Project, all excavated, steep-walled holes or trenches more than two feet deep should be covered at the close of each working day by plywood or similar materials. If the trenches cannot be closed, one or more escape ramps constructed of earthen fill or

wooden planks should be installed. Before such holes or trenches are filled, they should be thoroughly inspected for trapped animals.

- Wildlife are often attracted to burrow- or den-like structures such as pipes, and may enter stored pipes and become trapped or injured. To prevent wildlife use of these structures, all construction pipes, culverts, or similar structures with a diameter of four inches or greater should be capped while stored onsite.
- All food-related trash items such as wrappers, cans, bottles, and food scraps should be disposed of in securely closed containers and removed at least once a week from a construction or Project Area.
- Use of rodenticides and herbicides within the Project Area should be restricted. This is necessary to prevent primary or secondary poisoning of wildlife, including burrowing owl and the depletion of prey populations on which they depend. All uses of such compounds should observe label and other restrictions mandated by the USEPA, California Department of Food and Agriculture, and other state and federal legislation. If rodent control must be conducted, zinc phosphide should be used because of a proven lower risk to burrowing owl.

BIO-9 Compliance with Section 4150 of California Fish and Game Code: To avoid impacts to bat species, a qualified bat biologist should conduct an appropriate combination of sampling, exit counts, and acoustic surveys to determine if bats are using the palm tree resources in the Project Area. If Project-related impacts to bat species are unavoidable, additional measures may need to be implemented to reduce or eliminate impacts to bat species, including maternity roosts, such as tree removal occurring outside of bat breeding season (October through February) or two-step, two-day removal of palm trees under supervision of a qualified bat biologist.

7.0 CERTIFICATION

I hereby certify that the statements furnished above and in the attached exhibits present the data and information required for this biological evaluation, and that the facts, statements, and information presented are true and correct to the best of my knowledge and belief. Field work conducted for this assessment was performed by me or under my direct supervision. I certify that I have not signed a non-disclosure or consultant confidentiality agreement with the project applicant or the applicant's representative and that I have no financial interest in the project.

Signed: _____ Date: July 14, 2022
Caroline Garcia
Associate Biologist

Signed: _____ Date: July 14, 2022
Christina Torres
Associate Biologist

8.0 REFERENCES

- AOU. 2022. Check-list of North American Birds. Available online: <http://www.aou.org>.
- Baldwin, B. G., D. H. Goldman, D. J. Keil, R. Patterson, T. J. Rosatti, and D. H. Wilken, editors. 2012. The Jepson Manual: Vascular Plants of California, Second Edition. University of California Press, Berkeley, California. 1400 pp.
- Bradley, R.D., L.K. Ammerman, R.J. Baker, L.C. Bradley, J.A Cook, R.C. Dowler, C. Jones, D.J Schmidly, F.B. Stangl, Jr., R.A. Van Den Bussche, B. Wursig. 2014. Revised Checklist of North American Mammals North of Mexico. Museum of Texas Tech University.
- CalFlora: Information on California plants for education, research and conservation. [Web application]. 2022. Berkeley, California: The CalFlora Database [a non-profit organization]. Available online: <http://www.calflora.org>.
- CDFG. 2012. Staff Report on Burrowing Owl Mitigation. Dated March 7, 2012.
- _____. 1984. California Endangered Species Act. California Code of Regulations, Title 14, Chapter 5, Section 460. California Office of Administrative Law. Sacramento, CA.
- CDFW. 2022a. California Native Diversity Database. Rarefind 5 [computer program]. Sacramento (CA): State of California, the Resources Agency, Department of Fish and Wildlife. Accessed on September 14, 2020 and April 5, 2022.
- _____. 2022b. Special Animals List. Sacramento (CA): State of California, the Resources Agency, Department of Fish and Wildlife.
- _____. 2022c. State and Federally Listed Endangered and Threatened Animals of California. Sacramento (CA): State of California, Natural Resources Agency, Department of Fish and Wildlife. Dated April 2022.
- CDFW. 2018. Protocols for Surveying and Evaluating Impacts to Special Status Native Plant Populations and Sensitive Natural Communities. Sacramento, California.
- CNPS. 2022. Inventory of Rare and Endangered Plants (online edition, v7-08c). Rare Plant Scientific Advisory Committee. California Native Plant Society. Sacramento, CA. Available online: <http://www.cnps.org/inventory>.
- _____. 2001. Inventory of Rare and Endangered Plants of California (sixth edition). Rare Plant Scientific Advisory Committee, David P. Tibor, Convening Editor. California Native Plant Society, Sacramento, CA. 388pp.
- ECORP. 2022. Jurisdictional Delineation Report for the Vega SES 4 Solar Project. Prepared for Vega SES 4, LLC., San Diego, California. November 2020 rev. April 2022.
- County of Imperial, Planning and Development Services Department. 2006. Imperial County Conservation and Open Space Element, El Centro, CA.

- Holland, R. 1986. Preliminary Descriptions of the Terrestrial Natural Communities of California. Department of Fish and Game, Sacramento, CA.
- NRCS. 2022a. Online Web Soil Survey. U.S. Department of Agriculture. Accessed on September 27, 2020. Available online: <http://websoilsurvey.nrcs.usda.gov>.
- NRCS. 2022b. Soil Data Access Hydric Soils List. Available at <https://www.nrcs.usda.gov/wps/portal/nrcs/main/soils/use/hydric/>. Accessed September 20, 2020.
- Oberbauer, Thomas, Meghan Kelly, and Jeremy Buegge. March 2008. Draft Vegetation Communities of San Diego County. Based on "Preliminary Descriptions of the Terrestrial Natural Communities of California", Robert F. Holland, Ph.D., October 1986.
- Sawyer, J. O., T. Keeler-Wolf, and J. M. Evens. 2009. A Manual of California Vegetation, 2nd ed. California Native Plant Society, Sacramento, CA.
- Skinner, M. W., and Pavlik (eds.). 1994. Inventory of Rare and Endangered Vascular Plants of California; Fifth Edition. California Native Plant Society, Sacramento, California.
- SSAR. 2017. Scientific and Standard English Names of Amphibians and Reptiles of North American North of Mexico, With Comments Regarding Confidence in our Understanding. Eighth Edition. Committee on Standard English and Scientific Names.
- USFWS. 2022a. National Wetland Inventory. <https://www.fws.gov/wetlands/data/Mapper.html>. Accessed on September 24, 2020 and April 22, 2022.
- _____. 2022b. IPAC Trust Resources List. <http://ecos.fws.gov/ipac/>. Accessed on September 24, 2020 and April 26, 2022.
- _____. 1996. USFWS Guidelines for Conducting and Reporting Botanical Inventories for Federally Listed, Proposed, and Candidate Plants.
- _____. 1918. Migratory Bird Treaty Act of 1918. Section 16 of the U.S. Code (703-712), as amended 1989.

LIST OF ATTACHMENTS

Attachment A – Representative Site Photographs

Attachment B – Special-Status Plant Potential For Occurrence

Attachment C – Special-Status Wildlife Potential For Occurrence

ATTACHMENT A

Representative Site Photographs

Attachment A: Representative Site Photographs



Photo 1. Southeastern section of the Project Area in disturbed lands, facing northeast.



Photo 2. Northeastern section of the Project Area in disturbed creosote bush – white bursage scrub habitat, facing west.



Photo 3. Disturbed arrow weed scrub with tamarisk thickets in the background (circled in red) of the Project Area facing west.



Photo 4. Edge of tamarisk thickets in Project Area, facing west.



Photo 5. View of creosote bush scrub in the western section of the Project Area, facing west.



Photo 6. Close-up view of active burrowing owl burrow with whitewash and pellets near entrance, located in the southwestern section of the Project Area, facing southwest.



Photo 7. View of All-American Canal (within the northern buffer of the Project Area) lined with riparian vegetation, including arrow weed and tamarisk thickets, facing northwest.



Photo 8. View of U.S. Mexico border wall lining the southern perimeter of the Project Area, facing south.

Attachment A: Representative Site Photographs



Photo 9. View of creosote bush – white bursage scrub north of the access road, facing northwest.



Photo10. View of disturbed creosote bush scrub north of the bridge that crosses the All-American Canal that connects to the access road, facing west.



Photo 11. View of active cliff swallow mud nests on the Gordon Wells Road bridge crossing the offline storage canal for the All-American Canal, facing southeast.



Photo 12. View of the crevice housing a bat colony within the Gordon Wells Road bridge crossing the offline storage canal for the All-American Canal.

Attachment A: Representative Site Photographs



Photo 13. View of tamarisk thickets adjacent to the access road, facing northwest.



Photo 14. View of the access road, facing northeast.

Special-Status Plant Potential For Occurrence

Special-Status Plant Species Potential For Occurrence				
Scientific Name Common Name	Status	Blooming Period/ Elevation Range (meters)	Habitat	Potential to Occur in the Project site
<i>Amaranthus watsonii</i> Watson's amaranth	USFWS: None CDFW: None CRPR: 4.3	Apr-Sep (20 - 1700)	Mojavean desert scrub Sonoran desert scrub	Low: Habitat for this species occurs within the Project site. No CNDDDB records occur within 5 miles of the site.
<i>Astragalus magdalenae</i> var. <i>peirsonii</i> Peirson's milk-vetch	USFWS: Threatened CDFW: Endangered CRPR: 1B.2	Dec-Apr (60 - 225)	Desert dunes	Low: No habitat occurs within the Project site. One recent (2018) CNDDDB record occurs to the northeast, but not within 5 miles of the site.
<i>Astragalus sabulorum</i> gravel milk-vetch	USFWS: None CDFW: None CRPR: 2B.2	Feb-Jun (-60 - 930)	Desert dunes Mojavean desert scrub Sonoran desert scrub	Low: Habitat for this species occurs within the Project site. No CNDDDB records occur within 5 miles of the site.
<i>Croton wigginsii</i> Wiggins' croton	USFWS: None CDFW: Rare CRPR: 2B.2	Mar-May (50 - 100)	Desert dunes Sonoran desert scrub	Moderate: Habitat for this species occurs within the Project site. One recent CNDDDB record occurs from 2019 but is not within 5 miles of the site. Two historic CNDDDB records occur within 5 miles; the closest is located 0.92 miles east of the site from 1993.
<i>Euphorbia abramsiana</i> Abrams' spurge	USFWS: None CDFW: None CRPR: 2B.2	Sep-Nov (-5 - 1310)	Mojavean desert scrub Sonoran desert scrub	Moderate: Habitat for the species occurs within the Project site and a historic CNDDDB record (2010) occurs approximately three miles west of the site.
<i>Helianthus niveus</i> ssp. <i>tephrodes</i> Algodones Dunes sunflower	USFWS: None CDFW: Endangered CRPR: 1B.2	Sep-May (50 - 100)	Desert dunes	Low: No habitat occurs within the Project site. One recent observation of this species has occurred within approximately two miles of the Project site in 2018.
<i>Imperata brevifolia</i> California satintail	USFWS: None CDFW: None CRPR: 2B.1	Sep-May (0 - 1215)	Chaparral Coastal scrub Mojavean desert scrub Meadows and seeps Riparian scrub	Low: Habitat for this species occurs within the Project site. No CNDDDB records occur within 5 miles of the site.
<i>Johnstonella costata</i> ribbed cryptantha	USFWS: None CDFW: None CRPR: 4.3	Feb-May (-60 - 500)	Desert dunes Mojavean desert scrub Sonoran desert scrub	Low: Habitat for this species occurs within the Project site. No CNDDDB records occur within 5 miles of the site.

Special-Status Plant Species Potential For Occurrence				
Scientific Name Common Name	Status	Blooming Period/ Elevation Range (meters)	Habitat	Potential to Occur in the Project site
<i>Johnstonella holoptera</i> winged cryptantha	USFWS: None CDFW: None CRPR: 4.3	Mar-Apr (100 - 1690)	Mojavean desert scrub Sonoran desert scrub	Low: Habitat for this species occurs within the Project site. No CNDDDB records occur within 5 miles of the site.
<i>Mentzelia hirsutissima</i> hairy stickleaf	USFWS: None CDFW: None CRPR: 4.3	Mar-May (0 - 700)	Sonoran desert scrub	Low: Habitat for this species occurs within the Project site. No CNDDDB records occur within 5 miles of the site.
<i>Mentzelia puberula</i> Darlington's blazing star	USFWS: None CDFW: None CRPR: 2B.2	Mar-May (90 - 1280)	Mojavean desert scrub Sonoran desert scrub	Low: Habitat for this species occurs within the Project site. No CNDDDB records occur within 5 miles of the site.
<i>Nemacaulis denudata</i> var. <i>gracilis</i> slender cottonheads	USFWS: None CDFW: None CRPR: 2B.2	Apr-May (-50 - 400)	Coastal dunes Desert dunes Sonoran desert scrub	Low: Habitat for this species occurs within the Project site. No CNDDDB records occur within 5 miles of the site.
<i>Palafoxia arida</i> var. <i>gigantea</i> giant Spanish-needle	USFWS: None CDFW: None CRPR: 1B.3	Feb-May (15 - 100)	Desert dunes	Low: No habitat occurs within the Project site. One recent CNDDDB record occurs from 2013 but is not within 5 miles of the site. Two historic CNDDDB records occur within 5 miles of the site; the closest record is 0.4 miles north of the site from 1938 within sand dunes.
<i>Pholisma sonorae</i> sand food	USFWS: None CDFW: None CRPR: 1B.2	Apr-Jun (0 - 200)	Desert dunes Sonoran desert scrub	Moderate: Habitat for this species occurs within the Project site. One recent CNDDDB record occurs from 2018 but is not within 5 miles of the site. One historic CNDDDB record occurs within 5 miles of the Project site located 0.5 miles north of the site from 1954.

California Native Plant Society (CNPS) Rare Plant Ranks:

1B: Plants rare, threatened, and endangered in California and elsewhere.

2B: Plants rare, threatened, or endangered in California, but more common elsewhere.

4: Plants of limited distribution; a watch list.

CNPS Threat Ranks:

0.1: Seriously threatened in California (over 80% of occurrences threatened / high degree and immediacy of threat)

0.2: Fairly threatened in California (20-80% of occurrences threatened / moderate degree and immediacy of threat)

0.3-Not very threatened in California (less than 20% of occurrences threatened / low degree and immediacy of threat or no current threats known)

Sources:

California Natural Diversity Data Base (CNDDDB) (CDFW 2022)

CNPS Rare and Endangered Plant Inventory (CNPS 2022)

Calflora Information on California Plants (Calflora 2022)

IPaC (USFWS 2022)

Special-Status Wildlife Potential For Occurrence

Special-Status Wildlife Species Potential For Occurrence

Scientific Name Common Name	Status	Habitat Requirements	Potential for Occurrence
AMPHIBIANS			
BUFONIDAE (true toads)			
<i>Incilius alvarius</i> Sonoran Desert toad	USFWS: CDFW:	none SSC	Creosote bush desert scrub, grasslands up into oak-pine woodlands, thorn scrub and tropical deciduous forest in Mexico. Low. Limited suitable habitat within the buffer adjacent to the canal. No CNDDDB records occur within 5 miles of the site.
REPTILES			
PHRYNOSOMATIDAE (spiny lizards)			
<i>Phrynosoma mcallii</i> flat-tailed horned lizard	USFWS: CDFW:	none SSC	Desert scrub on sandy flats and valleys with little or no windblown sand, salt flats, and areas with gravelly soils. High. Suitable habitat on the Project site. Four recent CNDDDB records occur within 5 miles of the site. The closest recorded occurrence is less than 1 mile north of the site from 2014.
VIPERIIDAE (vipers)			
<i>Crotalus ruber</i> red-diamond rattlesnake	USFWS: CDFW:	none SSC	Found in coastal chaparral, arid scrub, rocky grassland, oak and pine woodlands, desert mountain slopes and rocky desert flats. Low. Marginally suitable habitat on the Project site. No CNDDDB records occur within 5 miles of the site.
BIRDS			
ACCIPITRIDAE (hawks, kites, harriers, and eagles)			
<i>Circus hudsonius</i> northern harrier	USFWS: CDFW:	none SSC	Undisturbed tracts of grasslands and wetlands with low, thick vegetation. Prefers to breed in dry upland habitats, old fields, grazed meadows, drained marshlands, and high-desert shrubsteppe. Also found in pasturelands, croplands, and open floodplains. Present. There was one sighting of northern harrier within the Project site. No CNDDDB records occur within 5 miles of the site.
ALAUDIDAE (larks)			
<i>Eremophila alpestris ssp. actia</i> California horned lark	USFWS: CDFW:	none WL	Bare open areas dominated by low vegetation or widely scattered shrubs, includes prairies, deserts, and plowed fields. Nests in a hollow on the ground. Moderate. The open areas of the Project site and within the buffer provide suitable habitat. No CNDDDB records occur within 5 miles of the site.
LANIIDAE (shrikes)			
<i>Lanius ludovicianus</i> loggerhead shrike (nesting)	USFWS: CDFW:	BCC SSC	Open country, with scattered shrubs and trees or other perches for hunting; includes agricultural fields, deserts, grasslands, savanna, and chaparral. Nests 2.5 to 4 feet off ground in thorny vegetation. Present. This species was observed within the tamarisk thickets in the western section of the Project site and within the creosote bush scrub adjacent to the access road. There is suitable nesting habitat within the Project site.

PARULIDAE (new world warblers)				
<i>Icteria virens</i> yellow-breasted chat	USFWS: CDFW:	none SSC	Riparian and upland thickets, and dry overgrown pastures. Prefers to nest in dense scrub along streams or at the edges of ponds or swamps.	Moderate. The dense arrow weed and tamarisk thickets within the Project site provide suitable nesting and foraging habitat for this species. No CNDDDB records occur within 5 miles of the site.
<i>Setophaga petechia</i> yellow warbler	USFWS: CDFW:	BCC SSC	Riparian woodlands especially with willows, open scrub, gardens, and thickets often near water.	Present. This species was observed within the tamarisk thickets in the western buffer of the Project site. This habitat provides suitable foraging and nesting areas for this species. No CNDDDB records occur within 5 miles of the site.
PICIDAE (woodpeckers)				
<i>Melanerpes uropygialis</i> Gila woodpecker	USFWS: CDFW:	none END	Arid environments, especially deserts and dry forests of the southwestern U.S. and adjacent Mexico, usually below elevations of 3,300 feet. Most common in low swales and arroyos, including riparian corridors with cottonwood, willow, and mesquite. Nests in cacti and other tree species.	Presumed Absent. Unlikely to occur onsite due to absence of suitable nesting cavity locations, i.e. large trees and/or cacti. No recent CNDDDB records occur within 5 miles of the site.
POLIOPTILIDAE (gnatcatchers)				
<i>Poliioptila melanura</i> black-tailed gnatcatcher	USFWS: CDFW:	none WL	Semi-arid and desert thorn scrub habitats. This species is well adapted to dry habitats and tend to be most common in areas with less than 8 inches of annual rainfall. They often live far from streams and other bodies of water.	Present. A pair was observed in the tamarisk thickets in the southwestern buffer of the Project. Tamarisk thickets are suitable foraging and nesting habitat for this species. No CNDDDB records occur within 5 miles of the site.
RALLIDAE (rails)				
<i>Laterallus jamaicensis ssp. coturniculus</i> California black rail	USFWS: CDFW:	BCC THR, FP	Riparian marshes, coastal prairies, saltmarshes, and impounded wetlands. All of its habitats have stable shallow water, usually just 1.2 inches deep at most.	Moderate. Moderately suitable nesting and foraging habitat for this species is present within the buffer of the Project site adjacent to the canal. One recent CNDDDB record occurs approximately 1 mile northeast of the site, directly north of the access road where individuals were detected within emergent wetland vegetation adjacent to the All-American Canal in 2008. Emergent wetland vegetation included seep wetlands characterized by bulrush, cattails, common reed, and scattered willows. A wetland enhancement project is underway in the area.

<i>Rallus obsoletus ssp. yumanensis</i> Yuma Ridgway's rail	USFWS: CDFW:	END THR, FP	Consistently found in freshwater marshes that are composed of cattail and bulrush. This emergent vegetation averages greater than 6 feet tall. Water depth tends to be around 3.5 inches deep. Range extends from Nevada, California, and Arizona to Baja California and Sonora Mexico.	Moderate. Presence of cattail dominated wetland habitat within the tamarisk and arrow weed thickets on the Project site are suitable foraging habitats for this species, however area lack consistent water The All-American Canal within the buffer of the Project site provides suitable habitat. Three CNDDDB records occur within 5 miles of the site. The most recent record occurs approximately 1 mile northeast of the site, directly north of the access road from 2008. The species was found within the All-American Canal.
TYRANNIDAE (tyrant flycatchers)				
<i>Empidonax traillii ssp. extimus</i> southwestern willow flycatcher	USFWS: CDFW:	END END	Riparian woodlands particularly with willow thickets. Nests in densest areas of shrubs and trees with low-density canopies.	Low. Suitable tamarisk and arrow weed riparian woodland habitat on the Project site but no presence of willows. No CNDDDB records within 5 miles of the site.
STRIGIDAE (owls)				
<i>Athene cunicularia</i> burrowing owl	USFWS: CDFW:	none SSC	Open grasslands including prairies, plains, and savannah, or vacant lots and airports. Nests in abandoned dirt burrows.	Present. A burrowing owl and two active satellite burrows were observed during the habitat assessment. Eight CNDDDB records within 5 miles of the site; two historic records and six recent records with the closest being 1.7 miles away in 2007.
MAMMALS				
MOLOSSIDAE (free-tailed bats)				
<i>Eumops perotis ssp. californicus</i> western mastiff bat	USFWS: CDFW:	none SSC	Roosts high above ground in rock and cliff crevices, shallow caves, and rarely in buildings. Occurs in arid and semiarid regions including rocky canyon habitats.	Presumed Absent. No suitable roosting habitat within site or in buffer. No CNDDDB records within 5 miles of the site.
<i>Nyctinomops macrotis</i> big free-tailed bat	USFWS: CDFW:	none SSC	Roosts in cliff crevices, and less often in buildings, caves, and tree cavities. Occurs in rocky areas of rugged and hilly country including woodlands, evergreen forests, river floodplain-arroyo habitats, and desert scrub.	Presumed Absent. No suitable roosting habitat within site or in buffer. No CNDDDB records within 5 miles of the site.
VESPERTILIONIDAE (evening bats)				
<i>Antrozous pallidus</i> pallid bat	USFWS: CDFW:	none SSC	Roosts in rock crevices, caves, mines, buildings, bridges, and in trees. Generally, in mountainous areas, lowland desert scrub, arid grasslands near water and rocky outcrops, and open woodlands.	Moderate. Suitable roosting habitat is present within the access road bridge over the offline storage reservoir, north of the All-American Canal. Additionally, desert scrub provides suitable foraging habitat. No CNDDDB records within 5 miles of the site.

<p><i>Corynorhinus townsendii</i> Townsend's big-eared bat</p>	<p>USFWS: CDFW:</p>	<p>none SSC</p>	<p>Roosts in mines, caves, buildings, or other crevices, sometimes trees. Usually requires large crevices. Most common in moist areas or those with access to water.</p>	<p>Moderate. Suitable roosting habitat is present within the access road bridge over the offline storage reservoir, north of the All-American Canal, additionally, desert scrub provides suitable foraging habitat. No CNDDDB records within 5 miles of the site.</p>
<p><i>Lasiurus xanthinus</i> western yellow bat</p>	<p>USFWS: CDFW:</p>	<p>none SSC</p>	<p>Roosts in trees, particularly palms, in desert wash, desert riparian, valley foothill riparian, and palm oasis habitats.</p>	<p>Moderate. Suitable roosting habitat is present within the palm trees of the Project site. This species has a strong association with roosting under dead palm frond skirts. No CNDDDB records within 5 miles of the site.</p>
<p><i>Myotis occultus</i> Arizona myotis</p>	<p>USFWS: CDFW:</p>	<p>none SSC</p>	<p>Roosts in bridges, buildings, tree snags. Most commonly found in high elevation conifer forests however maternity sites have been found at lower elevations within bridges and buildings</p>	<p>Moderate. Suitable roosting habitat is present within the access road over the offline storage reservoir, north of the All-American Canal. No CNDDDB records within 5 miles of the site.</p>
<p>CRICETIDAE (New World rats and mice)</p>				
<p><i>Sigmodon hispidus ssp. eremicus</i> Yuma hispid cotton rat</p>	<p>USFWS: CDFW:</p>	<p>none SSC</p>	<p>Inhabits a variety of habitats, but generally associated with drainage ditches, canals, and seeps vegetated with plants such as arrow weed, saltgrass, common reed, cattails, sedges, tamarisk, heliotrope, and annual grasses. They utilize runways through dense herbaceous growth and nests are built of woven grass. Noted presence in moist agricultural fields.</p>	<p>High. There is suitable habitat in the arrow weed and tamarisk thickets within the Project site. Two recent CNDDDB records occur less than 1 mile north of the access road for the site. This species was found in arrow weed scrub and freshwater marsh adjacent to the All-American Canal in 2007.</p>
<p>Federal Designations: (Federal Endangered Species Act, USFWS)</p> <p>END: Federally-listed, Endangered THR: Federally-listed, Threatened CAN: Federal Candidate Species FSC: Federal Species of Concern FPD: Federal Proposed for Delisting BCC: Bird of Conservation Concern</p>			<p>State Designations: (California Endangered Species Act, CDFW)</p> <p>END: State-listed, Endangered THR: State-listed, Threatened CAN: State Candidate Species SSC: California Species of Special Concern FP: Fully Protected Species WL: Watch List</p>	

Aquatic Resources Delineation

Vega SES 4 Solar Project

Imperial County, California

Prepared For:

Vega SES 4, LLC
604 Sutter Street
Suite 250
Folsom, California 95630
(916) 985-9461

Submitted by:

ECORP Consulting, Inc.
3838 Camino Del Rio North
Suite 370
San Diego, California 92108
(858) 279-4040

CONTENTS

1.0	INTRODUCTION	1
2.0	REGULATORY SETTING.....	12
2.1	Waters of the United States.....	12
2.1.1	Wetlands.....	12
2.1.2	Other Waters.....	12
2.2	Clean Water Act.....	12
2.3	Porter-Cologne Water Quality Act.....	13
2.4	California Fish and Game Code Section 1602.....	14
3.0	METHODS.....	15
3.1	Pre-Survey Investigations	15
3.2	Field Survey Investigation.....	15
3.3	Post-Processing	16
4.0	RESULTS.....	16
4.1	Existing Site Conditions	16
4.1.1	Vegetation Communities.....	17
4.1.2	Soils.....	18
4.1.3	National Wetland Inventory.....	19
4.1.4	Hydrology.....	38
4.2	Aquatic Resources	38
4.2.1	Wetlands.....	49
4.2.2	Other Aquatic Resources.....	49
4.2.3	Manmade Features.....	50
4.2.4	Associated Habitat.....	50
5.0	JURISDICTIONAL ASSESSMENT	51
6.0	CONCLUSION.....	51
7.0	REFERENCES.....	53

LIST OF TABLES

Table 1.	USGS Quadrangle Information.....	1
Table 2.	Summary of Federal, State, and Local Regulations.....	14
Table 3.	Rainfall Data Summary.....	17
Table 4.	Natural Resources Conservation Service Soil Types within the Study Area.....	19
Table 5.	Aquatic Resources within the Project.....	48

LIST OF FIGURES

Figure 1. Project Location and Vicinity 2
Figure 2. Site Plan..... 11
Figure 3. Natural Resources Conservation Service Soil Types..... 20
Figure 4. National Wetlands Inventory 29
Figure 5. Aquatic Resources Delineation 39

LIST OF ATTACHMENTS

- Attachment A – Driving Directions to Study Area
- Attachment B – OHWM and Wetland Determination Data Forms - Arid West
- Attachment C – Representative Site Photographs
- Attachment D – USACE ORM Aquatic Resources Table
- Attachment E – Digital Data

LIST OF ACRONYMS AND ABBREVIATIONS

°F	degrees Fahrenheit
CDFW	California Department of Fish and Wildlife
CFR	Code of Federal Regulations
CWA	Clean Water Act
ED	Ephemeral drainages
FEW	Freshwater emergent wetlands
FR	Federal Register
FSW	Freshwater forested/shrub wetlands
GIS	Geographic Information System
GPS	Global Positioning System
MW	Megawatt
NETROnline	Nationwide Environmental Title Research Online
NOAA	National Oceanic and Atmospheric Administration
NRCS	Natural Resources Conservation Service
NWI	National Wetlands Inventory
NWPR	Navigable Waters Protection Rule
OMBIL	Operations and Maintenance Business Information Link
OHWM	Ordinary high water mark
ORM	OMBIL Regulatory Module
PD	Perennial drainages
PJD	Preliminary Jurisdictional Delineation
Project	Vega SES 4 Solar Project

LIST OF ACRONYMS AND ABBREVIATIONS

RWQCB	Regional Water Quality Control Board
SAA	Streambed Alteration Agreement
SR	State Route
Study Area	Solar Project and 500-foot Buffer
sUAS	small unmanned aircraft system
SWRCB	State Water Resources Control Board
TNW	traditional navigable waters
USACE	U.S. Army Corps of Engineers
USEPA	U.S. Environmental Protection Agency
USGS	U.S. Geological Survey
WDR	Waste discharge regulations

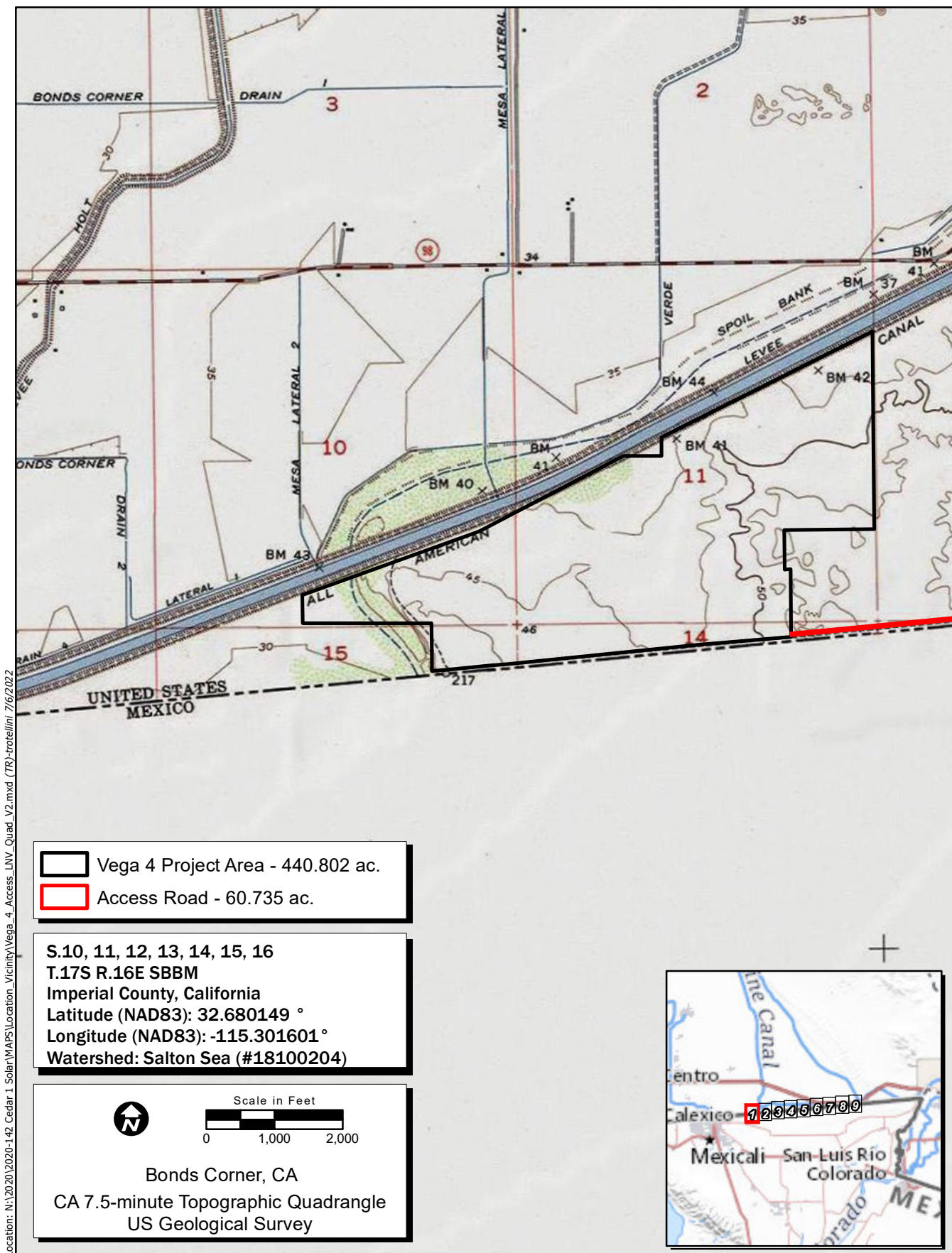
1.0 INTRODUCTION

This aquatic resources delineation report was prepared to describe the aquatic resources at the Vega SES 4 Solar Project (Project) located on ±511 acres of vacant land Imperial County, California. The Project includes a ±450-acre 100-Megawatt (MW) direct current and 400 MW-hour battery storage utility-scale solar project on two parcels (Assessor’s Parcel Numbers 059-300-015; 059-300-017). In addition, the Project includes a ±60-acre access road, totaling approximately 22 linear miles. For purposes of this report, “Study Area” refers to the solar field plus the access road, and a 150-foot buffer around each. The Project is within the southern portion of Imperial County, approximately nine miles southeast of Calexico, California and 0.5 mile south of California State Route (SR) 98. It resides in the middle of the All-American Canal to the north, and the U.S.-Mexico border, to the south. The access road runs east-west directly north and adjacent to the U.S./Mexico border wall (Figure 1. *Project Location and Vicinity*). A complete summary of geographic information for the Study Area is provided in Table 1. A map of the site is provided as Figure 2.

Table 1. USGS Quadrangle Information				
USGS 7.5-Minute Quad Map Name	Township	Range	Section(s)	Approximate Center of Study Area
Bonds Corner, CA (1976) Midway Well NW, CA (1979) Midway Well, CA (1979) Grays Well, CA (1976)	17S	16E 17E 18E 19E 20E	12, 13, 14 7, 8, 9, 10, 11, 12 1, 7, 8, 9, 10, 11, 12 1, 2, 3, 4, 5, 6 1, 6	32.682898, -115.304246

Driving directions to the Study Area are included as Attachment A. The Study Area is located on the south side of the All-American Canal and requires contacting U.S. Border Patrol prior to crossing the canal. After crossing the canal, turn right and follow the dirt access road along the canal for one mile.

This report describes aquatic resources identified within the Study Area that may be regulated by the Porter-Cologne Water Quality Act, California Fish and Game Code Sections 1600 and 1602, and the U.S. Army Corps of Engineers (USACE) pursuant to Sections 401 and 404 of the federal Clean Water Act (CWA). The information presented in this report provides data required by the USACE Los Angeles District’s Minimum Standards for Acceptance of Aquatic Resources Delineation Reports (USACE 2017). The aquatic resource boundaries depicted in this report represent a calculated estimation of the jurisdictional area within the Study Area and are subject to modification following the USACE verification process.



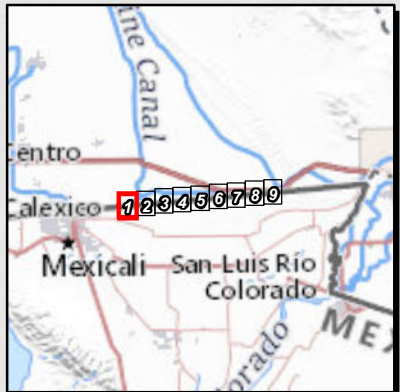
Location: N:\2020\2020-142_Cedar_1_Solar\WAPS\Location_Vicinity\Vega_4_Access_LNV_Quad_V2.mxd (TR) trottelli.m 7/6/2022

Vega 4 Project Area - 440.802 ac.
 Access Road - 60.735 ac.

S.10, 11, 12, 13, 14, 15, 16
T.17S R.16E SBBM
 Imperial County, California
 Latitude (NAD83): 32.680149 °
 Longitude (NAD83): -115.301601 °
 Watershed: Salton Sea (#18100204)

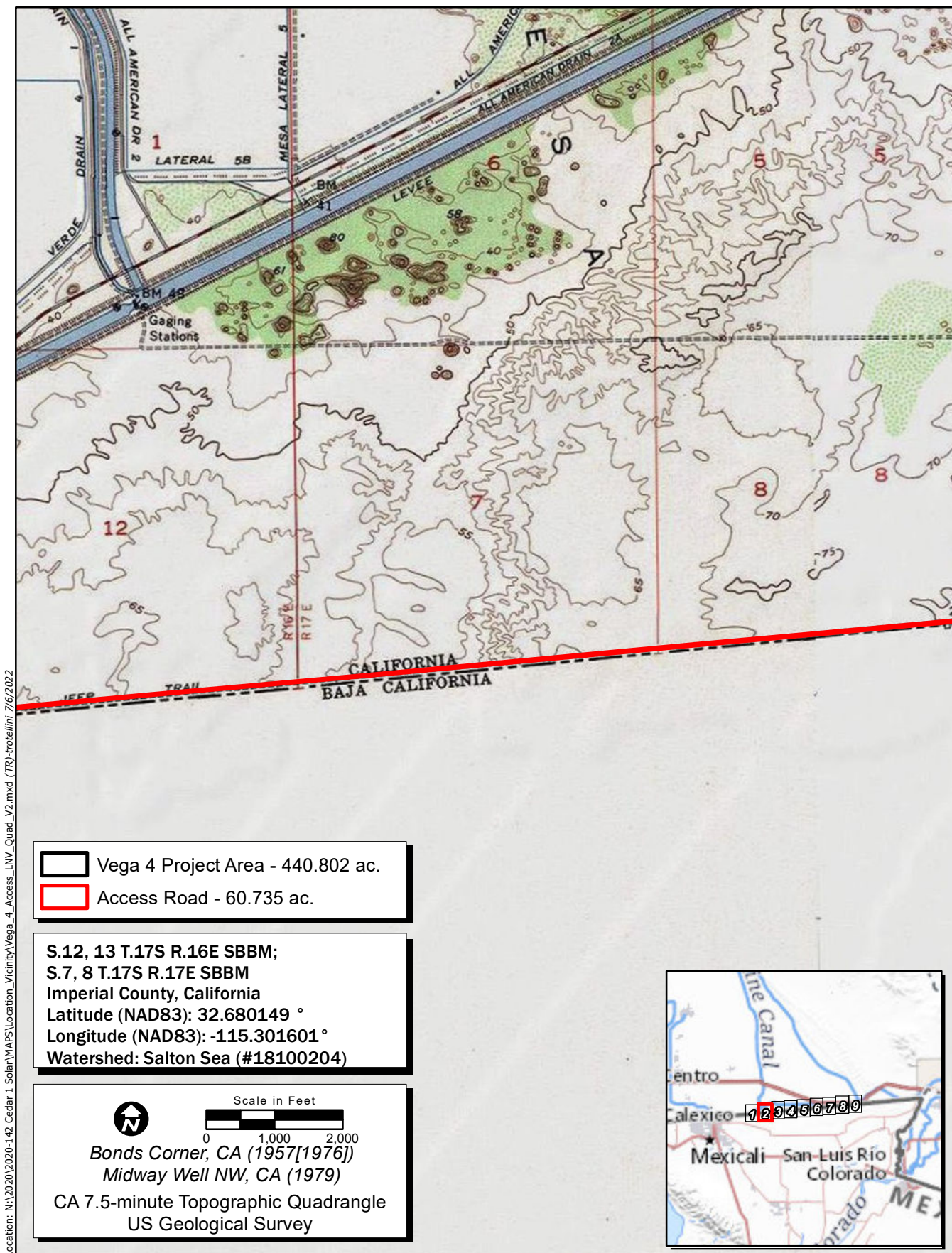
Scale in Feet

 Bonds Corner, CA
 CA 7.5-minute Topographic Quadrangle
 US Geological Survey



Map Date: 7/6/2022
 Service Layer Credits: Copyright © 2013 National Geographic Society, i-cubed

Figure 1. Project Location and Vicinity
Sheet 1 of 9



Location: N:\2020\2020-142_Cedar_1_Solar\WAPS\Location_Vicinity\Vega_4_Access_LNV_Quad_V2.mxd (TR) trocillini 7/6/2022

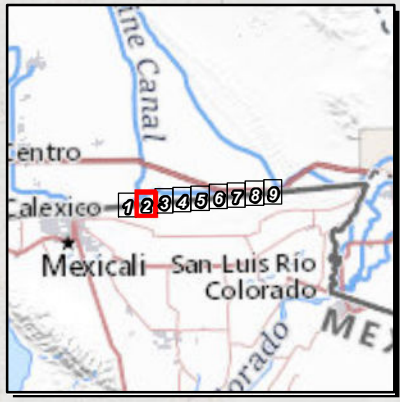
- Vega 4 Project Area - 440.802 ac.
- Access Road - 60.735 ac.

S.12, 13 T.17S R.16E SBBM;
S.7, 8 T.17S R.17E SBBM
 Imperial County, California
 Latitude (NAD83): 32.680149 °
 Longitude (NAD83): -115.301601 °
 Watershed: Salton Sea (#18100204)

Scale in Feet

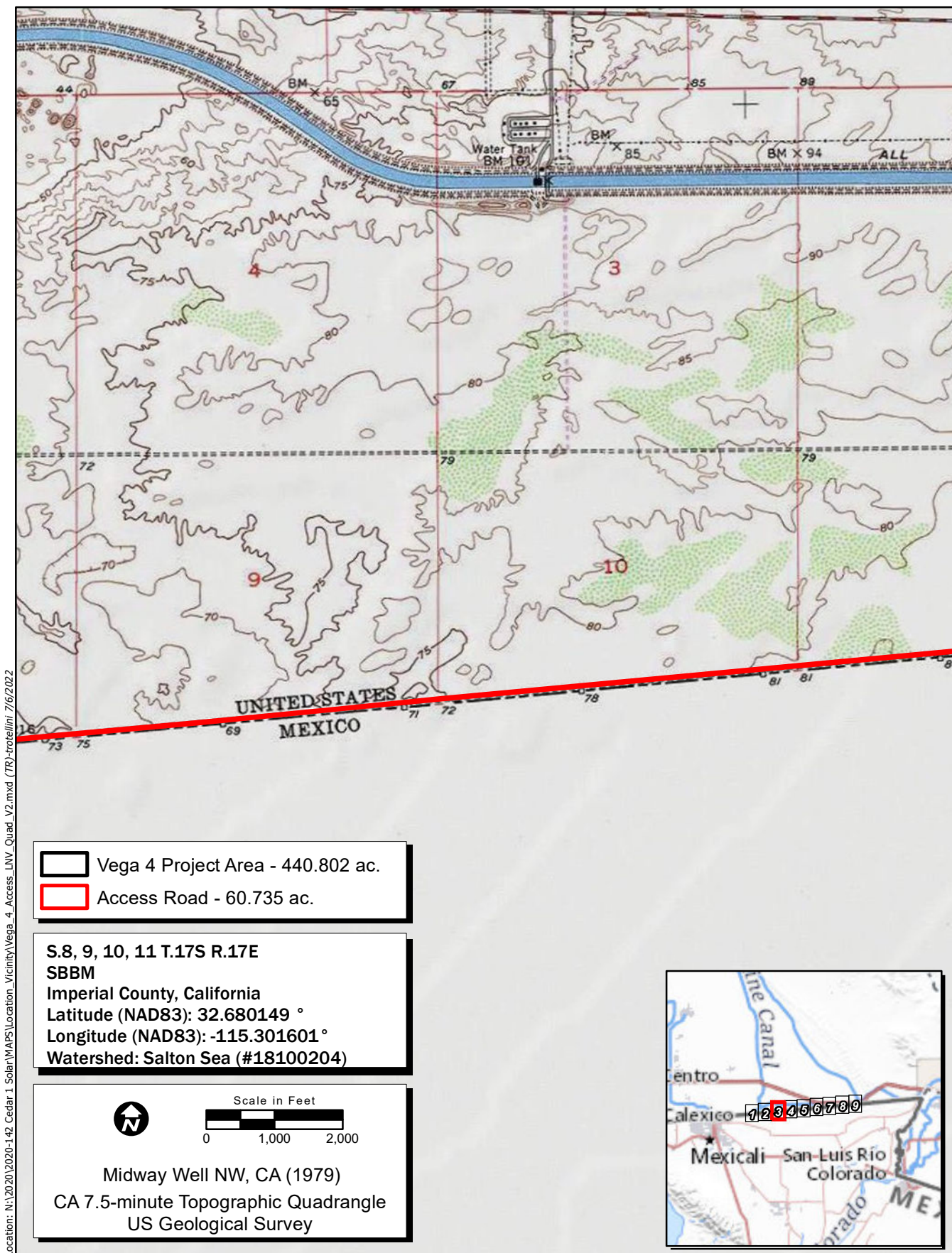
0 1,000 2,000

Bonds Corner, CA (1957[1976])
Midway Well NW, CA (1979)
 CA 7.5-minute Topographic Quadrangle
 US Geological Survey



Map Date: 7/6/2022
 Service Layer Credits: Copyright © 2013 National Geographic Society, i-cubed

Figure 1. Project Location and Vicinity
Sheet 2 of 9



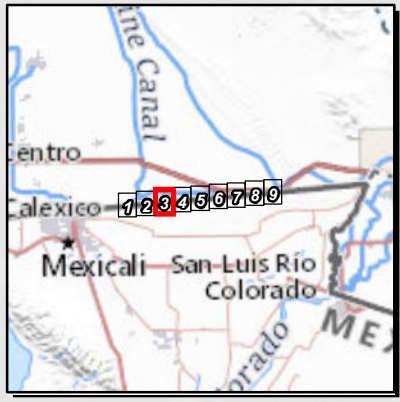
Location: N:\2020\2020-142_Cedar_1_Solar\WAPS\Location_Vicinity\Vega_4_Access_LNW_Quad_V2.mxd (TR) trocellini 7/6/2022

Vega 4 Project Area - 440.802 ac.
 Access Road - 60.735 ac.

S.8, 9, 10, 11 T.17S R.17E
SBBM
 Imperial County, California
 Latitude (NAD83): 32.680149 °
 Longitude (NAD83): -115.301601 °
 Watershed: Salton Sea (#18100204)

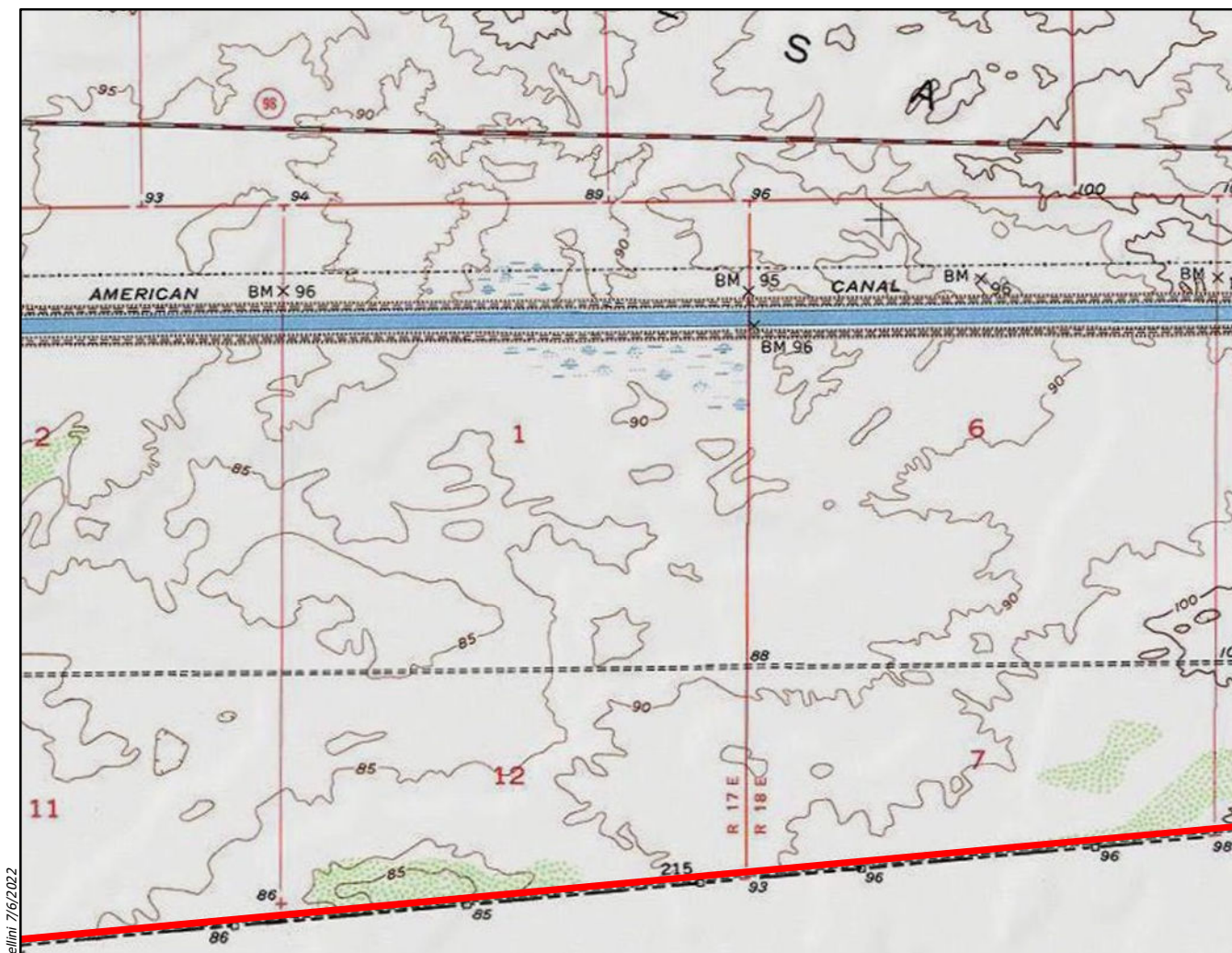
Scale in Feet

 Midway Well NW, CA (1979)
 CA 7.5-minute Topographic Quadrangle
 US Geological Survey



Map Date: 7/6/2022
 Service Layer Credits: Copyright © 2013 National Geographic Society, i-cubed

Figure 1. Project Location and Vicinity
Sheet 3 of 9



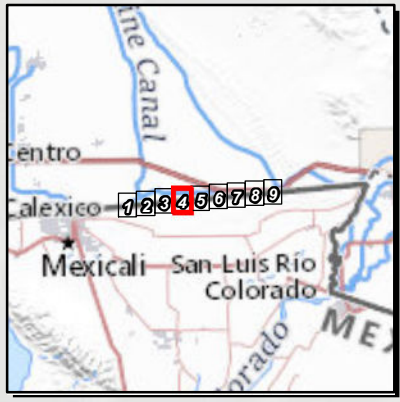
Location: N:\2020\2020-142_Cedar_1_Solar\WAPS\Location_Vicinity\Vega_4_Access_LNV_Quad_V2.mxd (TR) tracellini 7/6/2022

- Vega 4 Project Area - 440.802 ac.
- Access Road - 60.735 ac.

**S.11, 12 T.17S R.17E SBBM;
S.7, 8 T.17S R.18E SBBM**
Imperial County, California
Latitude (NAD83): 32.680149 °
Longitude (NAD83): -115.301601 °
Watershed: Salton Sea (#18100204)

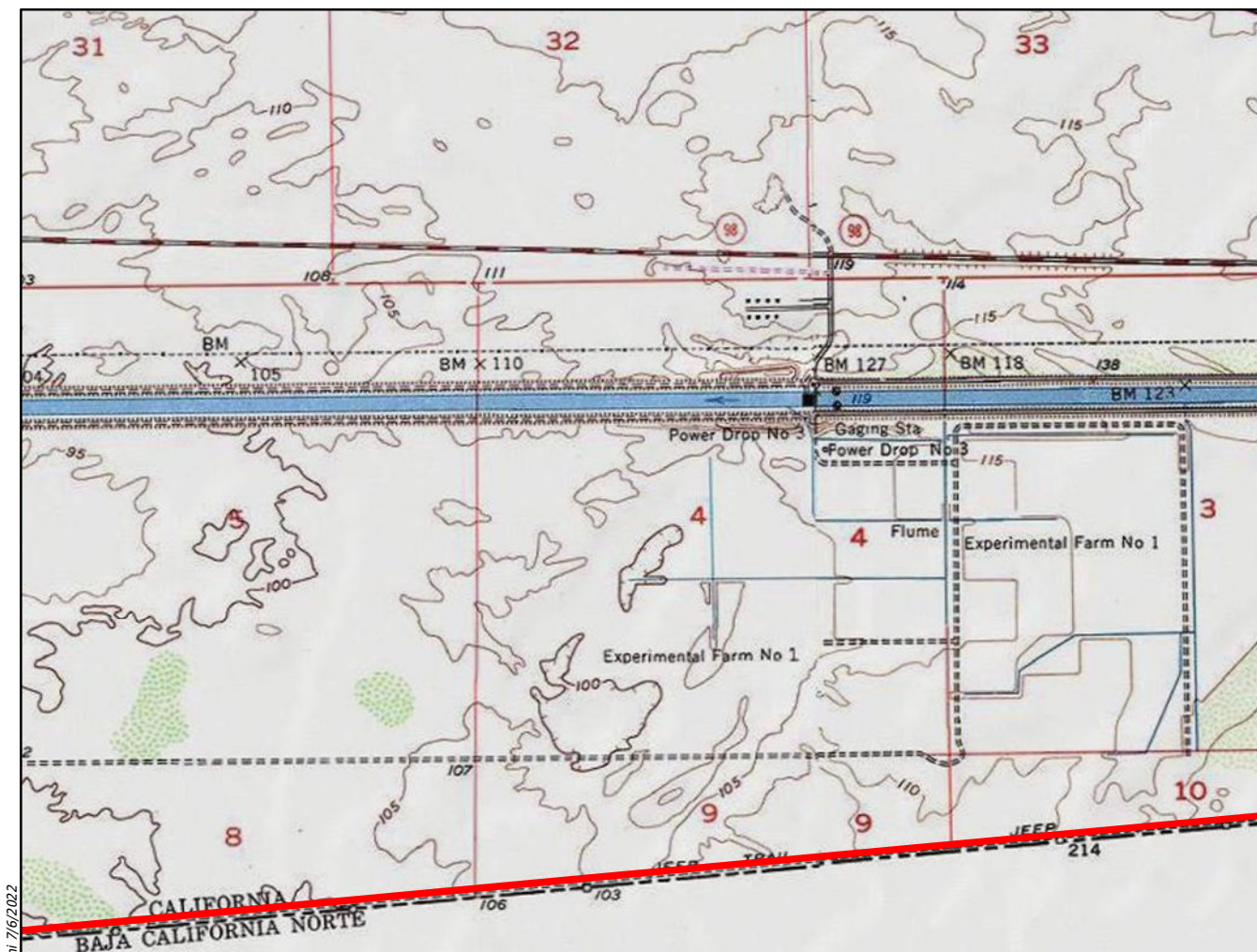
Scale in Feet

Midway Well NW, CA (1979)
CA 7.5-minute Topographic Quadrangle
US Geological Survey



Map Date: 7/6/2022
Service Layer Credits: Copyright © 2013 National Geographic Society, i-cubed

Figure 1. Project Location and Vicinity
Sheet 4 of 9



Location: N:\2020\2020-142_Cedar_1_Solar\WAPS\Location_Vicinity\Vega_4_Access_LNV_Quad_V2.mxd (TR) troteilini 7/6/2022

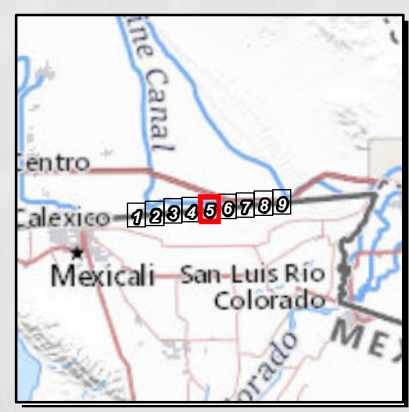
- Vega 4 Project Area - 440.802 ac.
- Access Road - 60.735 ac.

S.8, 9, 10 T.17S R.18E SBBM

Imperial County, California
 Latitude (NAD83): 32.680149 °
 Longitude (NAD83): -115.301601 °
 Watershed: Salton Sea (#18100204)

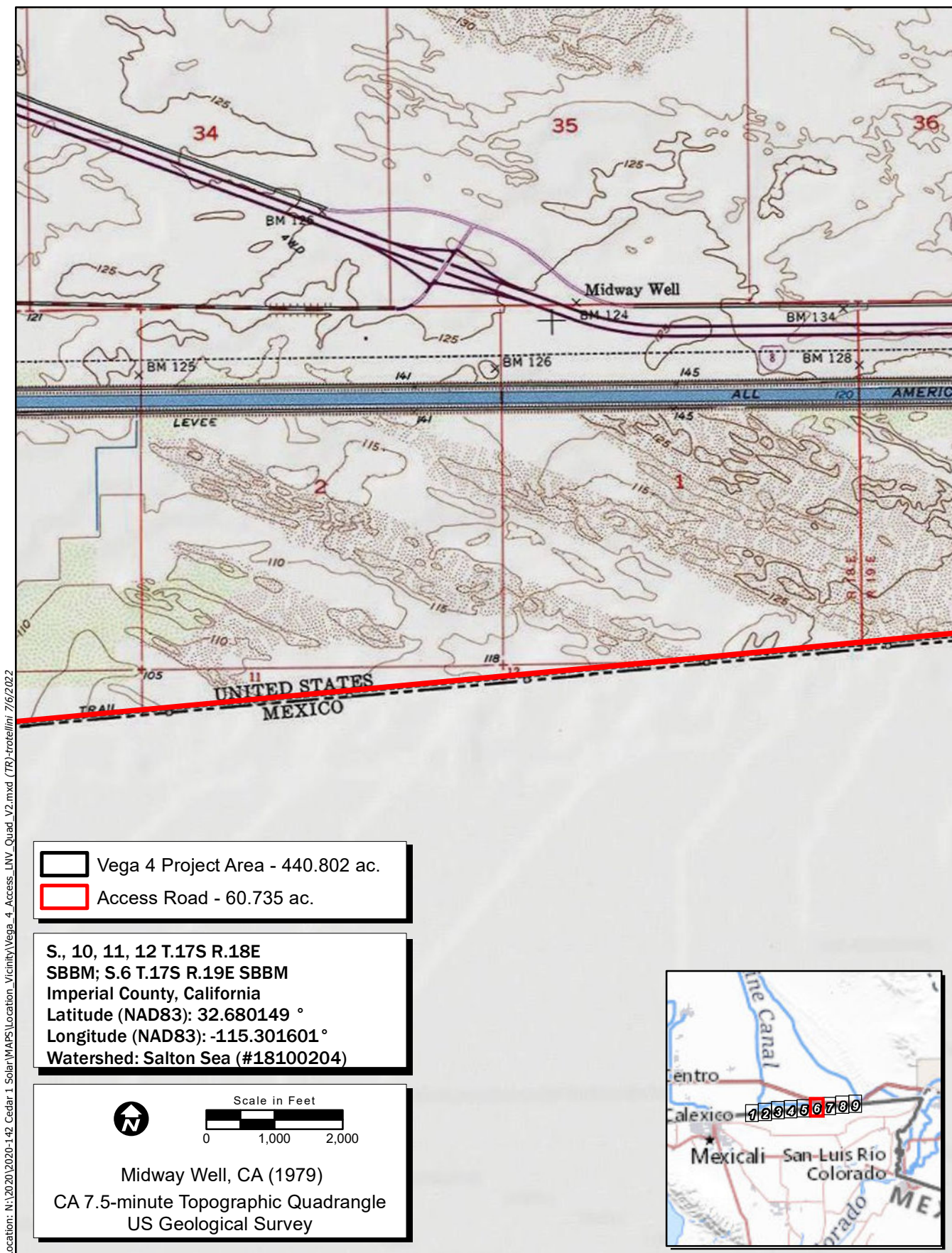
Scale in Feet

Midway Well NW, CA (1979)
 Midway Well, CA (1979)
 CA 7.5-minute Topographic Quadrangle
 US Geological Survey



Map Date: 7/6/2022
 Service Layer Credits: Copyright © 2013 National Geographic Society, i-cubed

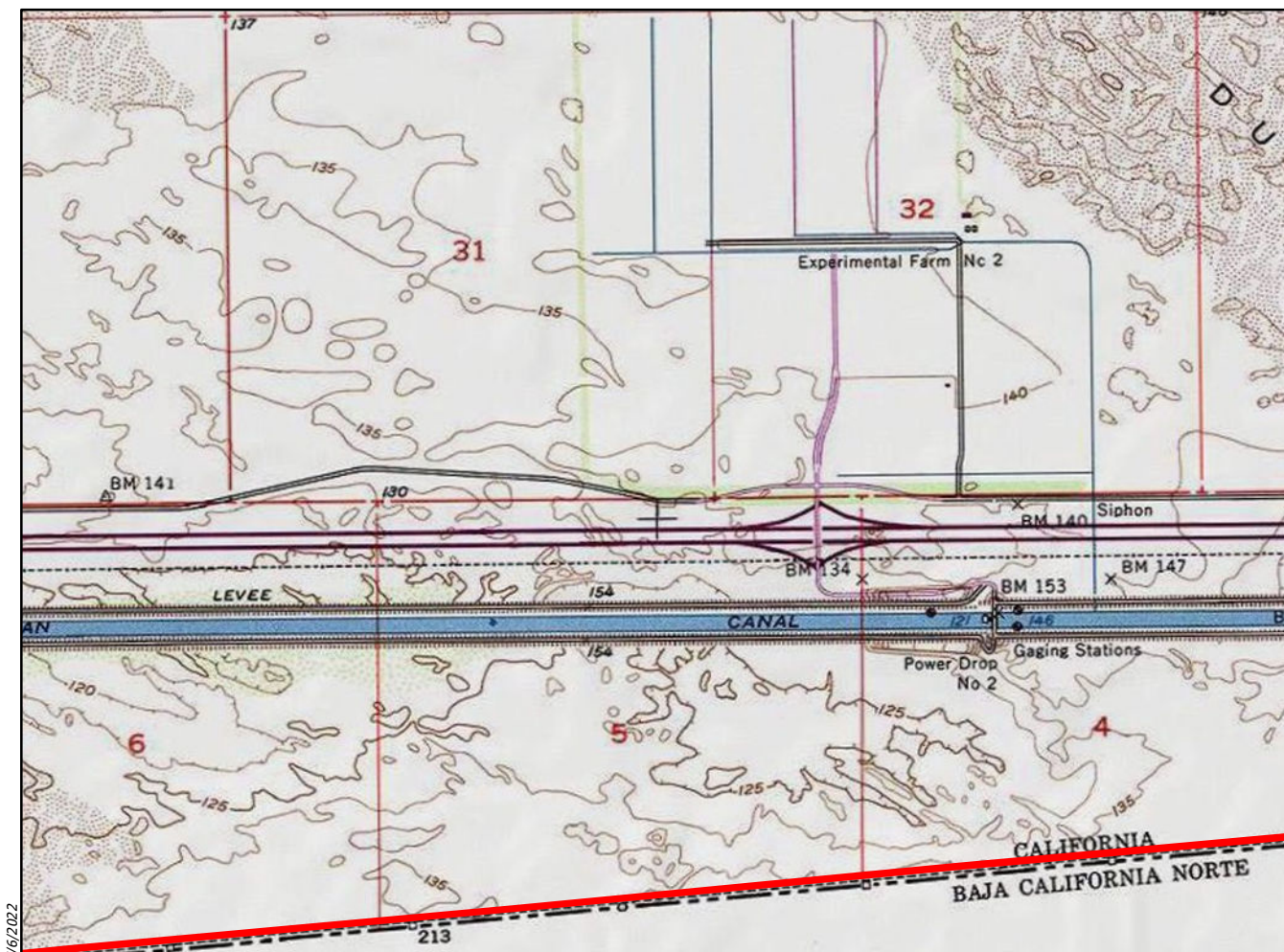
Figure 1. Project Location and Vicinity
Sheet 5 of 9



Location: N:\2020\2020-142_Cedar_1_Solar\WAPS\Location_Vicinity\Vega_4_Access_LNV_Quad_V2.mxd (TR):tracellini 7/6/2022

Map Date: 7/6/2022
 Service Layer Credits: Copyright © 2013 National Geographic Society, i-cubed

Figure 1. Project Location and Vicinity
Sheet 6 of 9



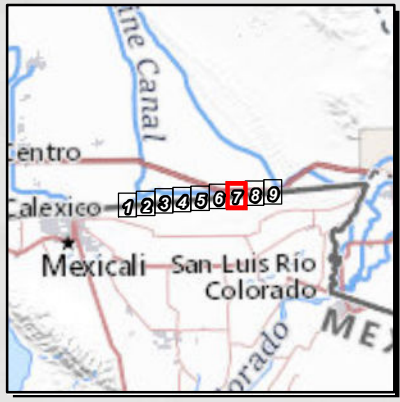
Location: N:\2020\2020-142_Cedar_1_Solar\WAPS\Location_Vicinity\Vega_4_Access_LNV_Quad_V2.mxd (TR) - trottelli 7/6/2022

- Vega 4 Project Area - 440.802 ac.
- Access Road - 60.735 ac.

S.4, 5, 6 T.17S R.19E SBBM
 Imperial County, California
 Latitude (NAD83): 32.680149 °
 Longitude (NAD83): -115.301601 °
 Watershed: Salton Sea (#18100204)

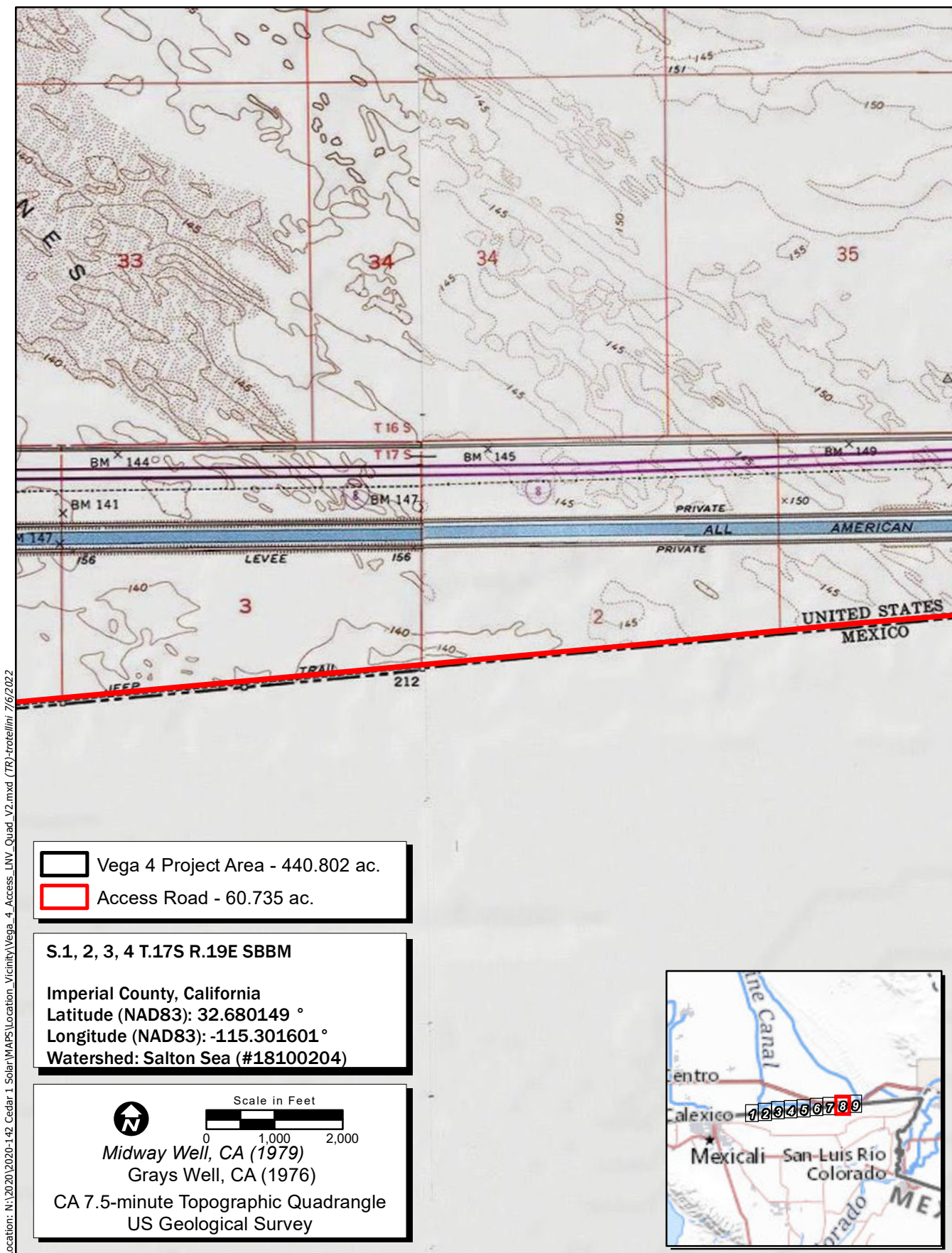
Scale in Feet

Midway Well, CA (1979)
 CA 7.5-minute Topographic Quadrangle
 US Geological Survey



Map Date: 7/6/2022
 Service Layer Credits: Copyright © 2013 National Geographic Society, i-cubed

Figure 1. Project Location and Vicinity
Sheet 7 of 9




Location: N:\2020\2020-142_Cedar_1_Solar\WAPS\Location_Vicinity\Vega_4_Access_LNV_Quad_V2.mxd (TR) trocillini 7/6/2022

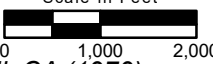
- Vega 4 Project Area - 440.802 ac.
- Access Road - 60.735 ac.

S.1, 2, 3, 4 T.17S R.19E SBBM

Imperial County, California
 Latitude (NAD83): 32.680149 °
 Longitude (NAD83): -115.301601 °
 Watershed: Salton Sea (#18100204)



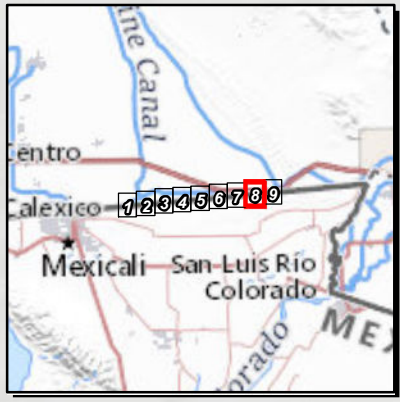
Scale in Feet



0 1,000 2,000

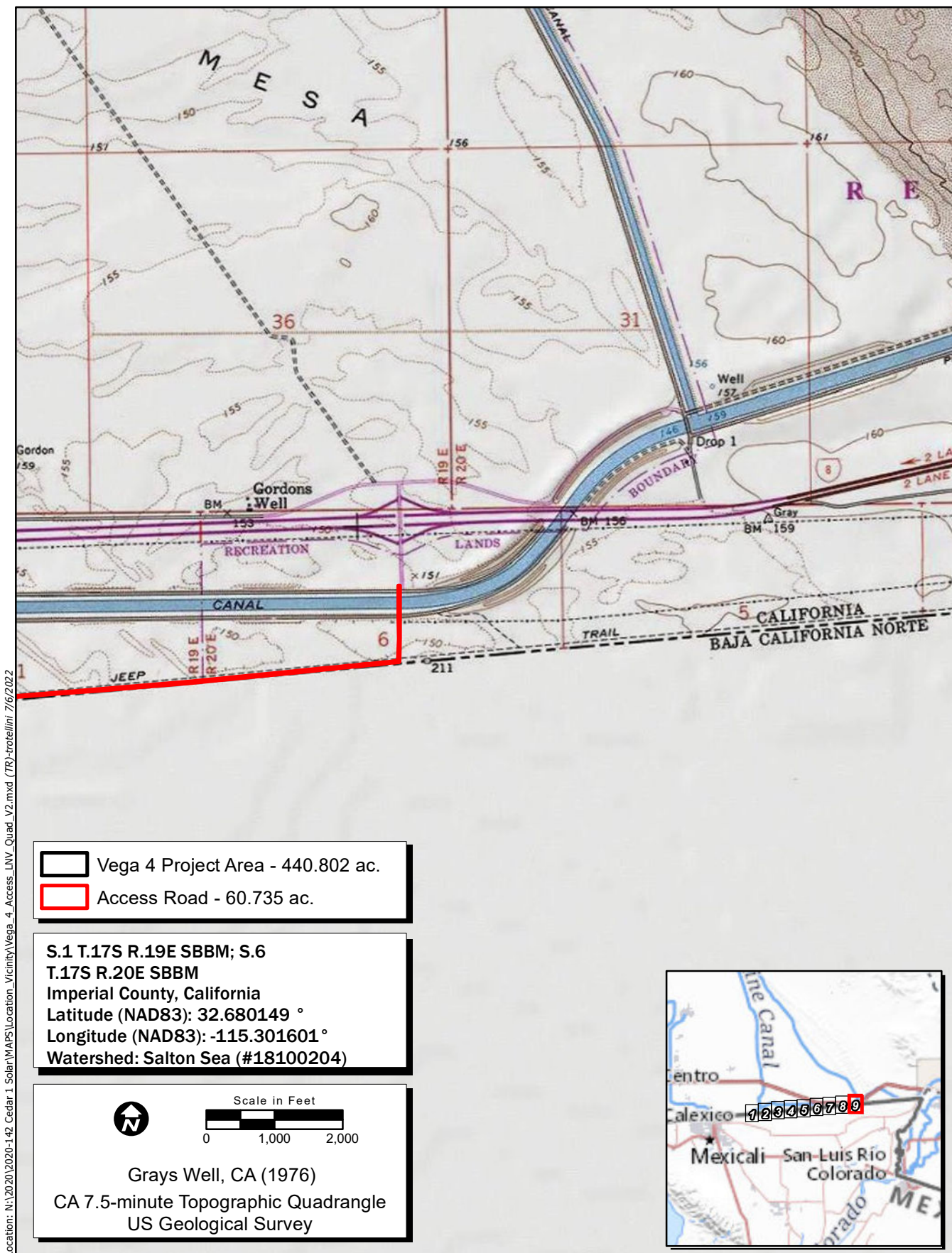
Midway Well, CA (1979)
 Grays Well, CA (1976)

CA 7.5-minute Topographic Quadrangle
 US Geological Survey



Map Date: 7/6/2022
 Service Layer Credits: Copyright © 2013 National Geographic Society, i-cubed


Figure 1. Project Location and Vicinity
Sheet 8 of 9



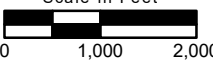
Location: N:\2020\2020-142_Cedar_1_Solar\WAPS\Location_Vicinity\Vega_4_Access_LNV_Quad_V2.mxd (TR) trocchini 7/6/2022

- Vega 4 Project Area - 440.802 ac.
- Access Road - 60.735 ac.

**S.1 T.17S R.19E SBBM; S.6
T.17S R.20E SBBM**
Imperial County, California
Latitude (NAD83): 32.680149 °
Longitude (NAD83): -115.301601 °
Watershed: Salton Sea (#18100204)

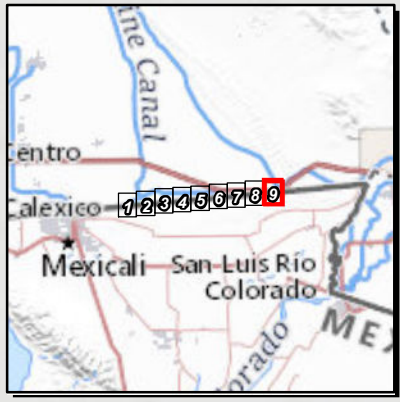


Scale in Feet



0 1,000 2,000

Grays Well, CA (1976)
CA 7.5-minute Topographic Quadrangle
US Geological Survey



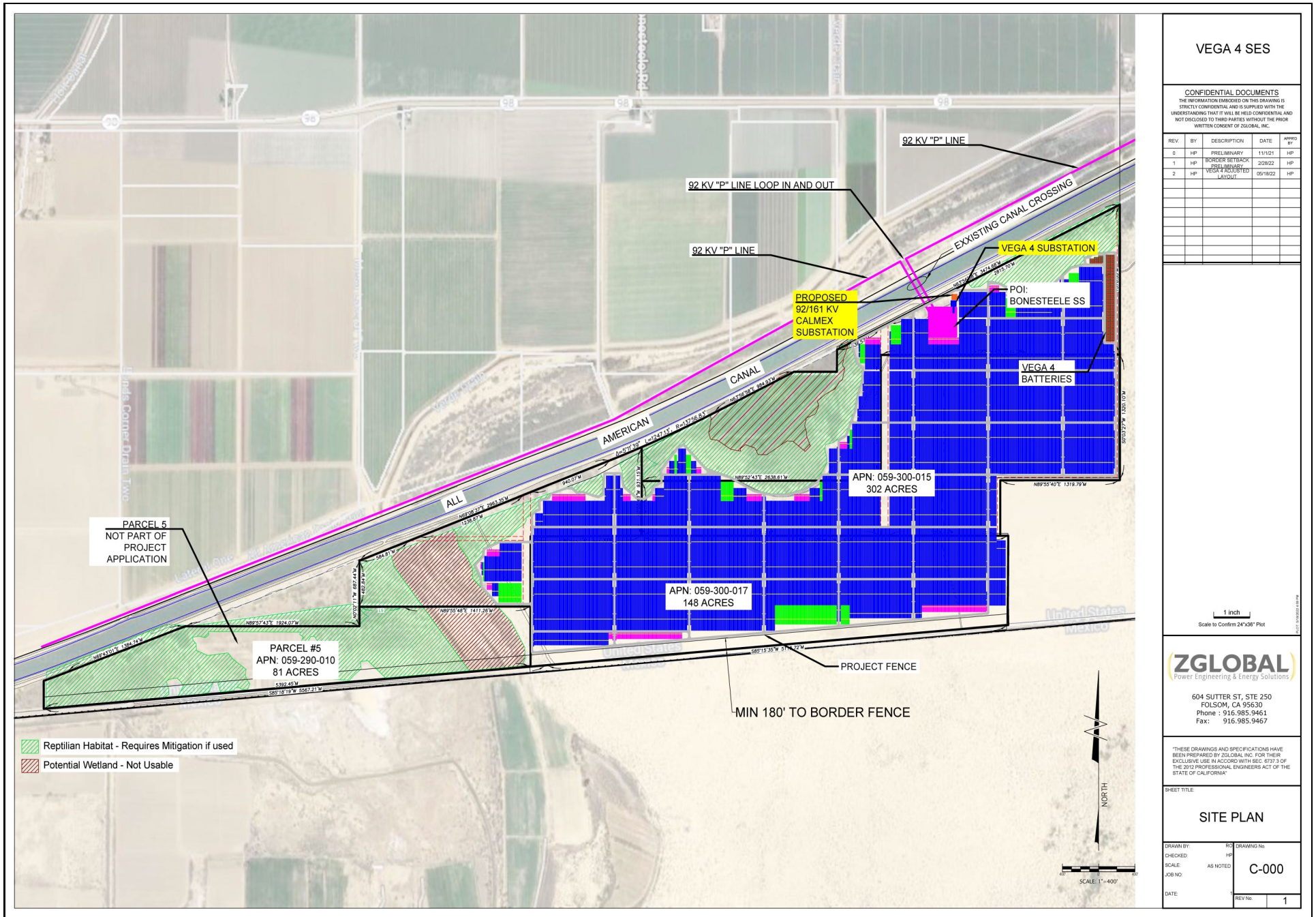
Map Date: 7/6/2022
Service Layer Credits: Copyright © 2013 National Geographic Society, i-cubed

Figure 1. Project Location and Vicinity
Sheet 9 of 9

2020-142 Vega SES 4



PC ORIGINAL PKG



2.0 REGULATORY SETTING

2.1 Waters of the United States

This report describes aquatic resources, including wetlands, that may be regulated by the USACE under Section 404 of the federal CWA. Waters of the U.S. includes both wetlands and other waters, as described below.

2.1.1 Wetlands

Wetlands are defined as “those areas that are inundated or saturated by surface or groundwater at a frequency and duration sufficient to support, and that under normal circumstances do support, a prevalence of vegetation typically adapted for life in saturated soil conditions” (51 Federal Register [FR] 41250, Nov. 13, 1986, as amended at 58 FR 45036, Aug. 25, 1993). Wetlands can be perennial or intermittent.

2.1.2 Other Waters

Other waters that may be found in the Study Area are non-tidal, perennial, and intermittent watercourses and tributaries to such watercourses [51 FR 41250, Nov. 13, 1986, as amended at 58 FR 45036, Aug. 25, 1993]. The limit of USACE jurisdiction for non-tidal watercourses (without adjacent wetlands) is defined in 33 Code of Federal Regulations [CFR] 328.4(c)(1) as the “ordinary high water mark” (OHWM). The OHWM is defined as the “line on the shore established by the fluctuations of water and indicated by physical characteristics such as clear, natural line impressed on the bank, shelving, changes in the character of soil, destruction of terrestrial vegetation, the presence of litter and debris, or other appropriate means that consider the characteristics of the surrounding areas” approximation of the lateral limit of USACE jurisdiction. The upstream limits of other waters are defined as the point where the OHWM is no longer perceptible.

2.2 Clean Water Act

The USACE regulates discharge of dredged or fill material into waters of the U.S. under Section 404 of the CWA. *Discharges of fill material* is defined as the addition of fill material into waters of the U.S., including, but not limited to the following: placement of fill necessary for the construction of any structure, or impoundment requiring rock, sand, dirt, or other material for its construction; site development fills for recreational, industrial, commercial, residential, and other uses; causeways or road fills; and fill for intake and outfall pipes, and subaqueous utility lines [33 Code of Federal Regulations (CFR) § 328.2(f)]. In addition, Section 401 of the CWA (33 U.S. Code [USC] 1341) is regulated by the Regional Water Quality Control Board (RWQCB) and requires any applicant for a federal license or permit to conduct any activity that may result in a discharge of a pollutant into waters of the U.S. to obtain a certification that the discharge will comply with the applicable effluent limitations and water quality standards. Section 401 Certification, “gives states and authorized tribes the authority to grant or waive certification of proposed federal licenses or permits that may discharge into waters of the US” (33 USC 1251).

On April 21, 2020, the U.S. Environmental Protection Agency (USEPA) and the Department of the Army (Army) published the NWPR to define waters of the United States in the *Federal Register*. This rule became effective on June 22, 2020.

In August 2021, a judge in the U.S. District Court for the District of Arizona ruled to vacate the NWPR. On October 1, 2021, Judge Márquez of the U.S. District Court for the District of Arizona granted the United States Environmental Protection Agency (EPA) and United States Department of the Army, Corps of Engineers (Corps) an extension until November 30, 2021 to make proposals for further proceedings concerning challenges to the 2020 regulatory definition of the “Waters of the United States” (WOTUS) and Navigable Waters Protection Rule (NWPR). On December 7, 2021 the EPA and USACE announced a proposed rule to revise the definition of “waters of the United States.” This proposal would return to the pre-2015 definitions of waters of the U.S. The proposed rule was open for public comment until February 7, 2022. The final rule has not yet been issued.

In the USACE/USEPA CWA regulations (33 CFR 328.3[a]), the term “waters of the U.S.” is defined as follows:

1. All waters which are currently used, or were used in the past, or may be susceptible to use in interstate or foreign commerce, including all waters which are subject to the ebb and flow of the tide;
2. All interstate waters including interstate wetlands;
3. All other waters such as intrastate lakes, rivers, streams (including intermittent streams), mudflats, sandflats, wetlands, sloughs, prairie potholes, wet meadows, playa lakes, or natural ponds, the use, degradation or destruction of which could affect interstate or foreign commerce including any such waters: (i) Which are or could be used by interstate or foreign travelers for recreational or other purposes; or (ii) From which fish or shellfish are or could be taken and sold in interstate or foreign commerce; or (iii) Which are used or could be used for industrial purpose by industries in interstate commerce;
4. All impoundments of waters otherwise defined as waters of the U.S. under the definition;
5. Tributaries of waters identified in paragraphs (a)(1)-(4) of this section;
6. The territorial seas;
7. Wetlands adjacent to waters (other than waters that are themselves wetlands) identified in 1-6 above

2.3 Porter-Cologne Water Quality Act

The Porter-Cologne Water Quality Control Act requires “any person discharging waste, or proposing to discharge waste, within any region that could affect the waters of the State to file a report of discharge” with the RWQCB through State Wetland Definition and Procedures for Discharges of Dredged or Fill Material to Waters of the State (Procedures) (California Code of Regulations [CCR], title 23, § 3855) (State Water Resources Control Board [SWRCB] 2021). *Waters of the State* is defined as any surface water or groundwater, including saline waters, within the boundaries of the State (California Water Code § 13050[e]). Pollution is defined as an alteration of the quality of the waters of the state by waste to a degree that unreasonably affects its beneficial uses (California Water Code § 13050) and includes filling in

waters of the State. Note that CCR, title 23, § 3855 applies only to individual water quality certifications, but the new Procedures extend the application of § 3855 to individual waste discharge requirements for discharges of dredged or fill material to Waters of the State and waivers thereof.

A permit for impacts to Waters of the State would likely be required under the CWA and/or Porter-Cologne Water Quality Control Act. To determine whether a project should be regulated pursuant to the Porter-Cologne Water Quality Control Act, the RWQCB considers whether project activities could impact the quality of Waters of the State.

2.4 California Fish and Game Code Section 1602

Pursuant to Section 1602 of the California Fish and Game Code, a Streambed Alteration Agreement (SAA) application must be submitted for “any activity that may substantially divert or obstruct the natural flow or substantially change the bed, channel, or bank of any river, stream, or lake” (CDFW 2021). In Title 14 of the CCR, Section 1.72, the CDFW defines a *stream* (including creeks and rivers) as “a body of water that flows at least periodically or intermittently through a bed or channel having banks and supports fish or other aquatic life. This includes watercourses having a surface or subsurface flow that supports or has supported riparian vegetation.”

The CDFW’s jurisdiction includes drainages with a definable bed, bank, or channel with the jurisdictional limit being the top of bank (TOB). It also includes areas that support intermittent, perennial, or subsurface flows; supports fish or other aquatic life; or supports riparian or hydrophytic vegetation. It also includes areas that have a hydrologic source.

The CDFW will determine if the proposed actions will result in diversion, obstruction, or change of the natural flow, bed, channel, or bank of any river, stream, or lake that supports fish or wildlife. The CDFW will submit a SAA that includes measures to protect affected fish and wildlife resources; this SAA is the final proposal agreed upon by the CDFW and the applicant.

Table 2. Summary of Federal, State, and Local Regulations		
Federal Regulations		
Regulation	Resource	Regulating Agencies
Federal Clean Water Act	Aquatic features meeting the definition of Waters of the US	USACE, RWQCB
State Regulations		
Regulation	Resource	Regulating Agency
California Fish and Game Code Section 1602	River, stream, or lake and associated riparian habitat	CDFW
Local Regulations		
Regulation	Resource	Regulating Agency
Porter-Cologne Water Quality Act	Aquatic features meeting the definition of Waters of the State	RWQCB

3.0 METHODS

3.1 Pre-Survey Investigations

Due to the size of the area and limited road access, an initial survey utilizing a small, unmanned aircraft system (sUAS) was conducted to assess current site conditions and gather high-resolution imagery. Photos collected during the sUAS survey were then combined into a single orthomosaic image that was incorporated into mapping files in a Geographic Information System (GIS). The information gathered from the sUAS/drone survey were then used to assist delineation specialists with accurate mapping of potential aquatic resources onsite. Prior to conducting the field delineations, the following resources were reviewed to identify potentially jurisdictional areas: sUAS imagery, satellite aerial imagery (Google Earth 2018, ESRI 2022), the National Wetlands Database, the online web soil survey (Natural Resources Conservation Service [NRCS] 2022a), and hydric soils list for the area.

3.2 Field Survey Investigation

This aquatic resources delineation was conducted in accordance with the *Corps of Engineers Wetlands Delineation Manual* (Environmental Laboratory 1987), the *Regional Supplement to the Corps of Engineers Wetland Delineation Manual: Arid West Region* (USACE 2008a), *A Field Guide to the Identification of the Ordinary High Water Mark (OHWM) in the Arid West Region of the Western United States* (USACE 2008b), and the *Updated Datasheet for the Identification of the Ordinary High Water Mark (OHWM) in the Arid West Region of the Western United States* (USACE 2010). The boundaries of aquatic resources were delineated through standard field methods (e.g., paired sample set analyses) and aerial photograph interpretation. Field data was recorded on Wetland Determination Data Forms - Arid West Region and Arid West OHWM Datasheets (Attachment B). ESRI® and sUAS aerial imagery were used to assist with mapping and ground-truthing. *Munsell Soil Color Charts* (Kollmorgen Instruments Co. 1990) and the Web Soil Survey (NRCS 2020a) were used to aid in identifying hydric soils in the field. The Jepson Manual, 2nd Edition (Baldwin et al. 2012) and the USACE National Wetland Plant List (USACE 2018) were used for plant nomenclature and identification.

Where jurisdictional features were present, the extent of potential Waters of the State and CDFW-regulated streambed and top-of-bank limits were determined using the OHWM in accordance with USACE requirements and guidelines, as well as RWQCB and CDFW delineation guidance. Streambed widths were based on evidence of OHWM as observed during the field survey. In addition, each of the drainages were evaluated for the presence or absence of sediment deposits, litter/debris, water stains, soil shelving, and/or exposed roots indicating active hydrology within the channel. Streambed widths and other lateral limits of jurisdiction were calculated and recorded. The extent of associated riparian habitat was based on the extent of the canopy of the riparian community within or directly adjacent to the feature. Bank-to-bank width measures were also recorded and used as a measure of CDFW jurisdictional boundary where features lacked riparian vegetation. Feature characteristics and measurements were recorded directly into the data dictionary in the GPS unit. Characteristics of the majority of mapped features were also documented in photographs.

Paired locations were sampled to evaluate whether the vegetation, hydrology, and soils data supported an aquatic resource determination. At each paired location, one point was located such that it was within the estimated aquatic resource area, and the other point was situated outside the limits of the estimated aquatic resource area. Additional non-paired locations were sampled to confirm boundaries. Aquatic resources within the Study Area were recorded in the field using a post-processing capable Global Positioning System (GPS) unit with sub-meter accuracy (e.g., Juniper Geode™). Feature characteristics and measurements were recorded directly into the data dictionary in the GPS unit. Characteristics of mapped features were also documented in photographs.

Four separate field surveys were conducted by ECORP delineation specialists in 2020; the first being a general field reconnaissance of the Study Area to identify areas supporting potential state and federal jurisdictional waters. The initial survey was conducted in conjunction with the biological reconnaissance survey on September 28, 2020, by Christina Congedo, Caroline Garcia, Greg Hampton, and Christina Torres. The subsequent field surveys and formal delineations were conducted to verify preliminary results observed in the September survey and to collect additional data and photographs. These surveys were conducted on November 4-5, 2020, by Christina Congedo, Jennifer Kendrick, and Christina Torres; an additional survey was conducted on November 12, 2020, by Christina Congedo, Caroline Garcia, and Christina Torres. The entire Study Area was visually surveyed to determine the location and extent of aquatic resources, and special attention was given to the features identified during the initial survey described above. On April 12-13, 2022, Christina Torres and Caroline Garcia revisited the Study Area to assess the access road and verify that conditions of the solar field parcels had not changed since the 2020 surveys.

3.3 Post-Processing

The data collected in the field utilized ArcGIS™ Collector on a device (smartphone or tablet) connected to a submeter external receiver. The submeter receiver applies differential correction instantaneously in the field using the Satellite Based Augmentation System. The data were then viewed and analyzed for verification, edited, and compiled in GIS format at the time of download. ArcGIS™ software was used to develop the geodatabase and the shapefiles depicted on the figures included in this report.

4.0 RESULTS

4.1 Existing Site Conditions

The Study Area is located within relatively flat to gently sloping terrain situated at an elevational range of approximately 11 meters (38 feet) to 48 meters (159 feet) above mean sea level in Imperial County, California. The average winter low temperature in the vicinity of the Study Area is 44.0) and the average summer high temperature is 105.1°F. Average annual precipitation for El Centro is approximately 2.90 inches, which falls as rain (National Oceanic and Atmospheric Administration [NOAA] 2022a). A summary of rainfall data is provided in Table 3 below.

Table 3. Rainfall Data Summary			
Season	Station	Total Precipitation (Inches)	Average Precipitation per Event (Inches)
2018-2019 ¹	El Centro 2 SSW, CA US	2.72	0.544
2019-2020 ¹	El Centro 2 SSW, CA US	5.01	0.626
2020-2021 ¹	El Centro 2 SSW, CA US	0.880	0.440
2021-2022 ²	El Centro 2 SSW, CA US	0.470	0.157

¹ Rainfall Data from October 1- September 30 (NOAA 2022b)

² Rainfall Data from October 1 – April 11 (NOAA 2022b)

A typical year analysis of the Study Area via a single point method was conducted using the USACE Antecedent Precipitation Tool (APT, USACE 2021). The APT analysis determines whether precipitation, drought, and other climatic conditions from the previous three months are *wet*, *normal*, or *dry* for the geographic area based on a rolling 30-year period (USEPA 2022). The APT was run for the dates the wetland delineation data were collected between September 28, 2020, November 4-5, 2020, and November 12, 2020. The APT demonstrated the site conditions on these dates represent a time of year referenced as the dry season, that the general region and site were in a moderate to severe drought, and that site conditions were normal in climatic conditions. The APT was also run for the dates the wetland delineation data were collected between April 12-13, 2022. The APT demonstrated the site conditions on these dates represent a time of year referenced as the dry season, that the general region and site were in an extreme drought, and that site conditions were normal in climatic conditions.

4.1.1 Vegetation Communities

Vegetation within the Study Area is characteristic of creosote bush scrub, riparian scrub, and wetland habitats. The eastern portion of the solar field consists primarily of disturbed creosote – white bursage scrub and disturbed areas with bordering riparian scrub and wetland habitats to the northern edge and western section of the Project. The western portion of the solar field primarily consists of riparian scrub and wetland habitats. The access road and adjacent areas consist of a mosaic of creosote bush scrub, creosote bush – white bursage scrub, and tamarisk thickets. There are four types of vegetation communities occurring within the Project: arrow weed thickets (disturbed), creosote bush scrub, creosote bush scrub – white bursage scrub (disturbed), and tamarisk thickets. Three land use types also occur within the Project: disturbed, urban/developed, and urban/developed (roads). Four additional vegetation communities were observed within the buffer, but not within the Study Area, and include: creosote bush scrub – white bursage scrub, creosote bush scrub (disturbed), active agriculture, and fallow agriculture.

Arrow weed thickets are associated with moderate to dense scrub primarily dominated by arrow weed (*Pluchea sericea*). Other species that occur as scattered individuals included tamarisk (*Tamarix* spp.), willow baccharis (*Baccharis salicina*), and big saltbush (*Atriplex lentiformis*). Disturbed arrow weed thickets are arrow weed thickets that have been previously altered. On this Project, this vegetation cover is characterized as sparser. Other plant species observed included alkali goldenbush (*Isocoma acradenia*).

Creosote bush scrub is dominated by a nearly monotypic stand of creosote bush (*Larrea tridentata*) with an open canopy and an herbaceous layer of seasonal annuals and perennials. Other species that occurred on the Project included white bursage (*Ambrosia dumosa*), apricot mallow (*Sphaeralcea ambigua*), and fanleaf crinkle mat (*Tiquilia plicata*). Disturbed areas of this community were sparser with a higher density of nonnative herbs. Other plant species observed include ephedra (*Ephedra trifurca* and *Ephedra* sp.) and crinklemat.

Creosote bush – white bursage scrub consists of creosote bush and white bursage that are co-dominant in the shrub canopy with an absent to intermittent herbaceous layer of seasonal annuals. Along the access road, other plant species observed within this community include ephedra, alkali goldenbush, and scattered individuals of mesquite (*Prosopis* sp.). Within the planned solar field, this vegetation cover is disturbed and is characterized as sparser with a high percentage of nonnative plant species including common Mediterranean grass (*Schismus barbatus*) and Saharan mustard (*Brassica tournefortii*). Other plant species included dyebush (*Psoralea argyrea*) and fanleaf crinkle mat.

Tamarisk thickets are characterized by a weedy monoculture of tamarisk. Within the Study Area, tamarisk and arrow weed were often co-dominant in this vegetation community. Other plant species observed included cattails (*Typha* spp.), screw bean mesquite (*Prosopis pubescens*), and willow baccharis.

Disturbed land includes areas where the native vegetation community has been heavily influenced by human actions, such as grading, trash dumping, and off-highway vehicle use, but lack development. On this Project, the areas consisted primarily of bare ground and Mediterranean grass. Other plant species observed on the Project included dyebush and white bursage.

Areas mapped as developed have been constructed upon or otherwise physically altered to an extent that natural vegetation communities are no longer supported. On the Study Area, this land cover was dominant and consisted primarily of compacted dirt roads, structures, and landscape trees including Mexican fan palm (*Washingtonia robusta*) and Mexican palo verde (*Parkinsonia aculeata*).

Active agriculture includes planted, typically monotypic, rows of crops of annual and perennial species with open space between rows. Species composition frequently changes by season and year. Active agriculture often occurs in upland areas with high soil quality, or floodplains and are almost always artificially irrigated. This land cover was observed in the eastern portion and southwest of the solar field and south of the access road.

Fallow agricultural lands include remnant signs of row crops with open space between rows. Agricultural lands often occur in upland areas with high soil quality, or floodplains, and are almost always artificially irrigated. This land cover was observed periodically to the south of the access road within the country of Mexico. Access to view these areas was obstructed by the U.S./Mexico border wall, but unvegetated row crops were observed from a distance.

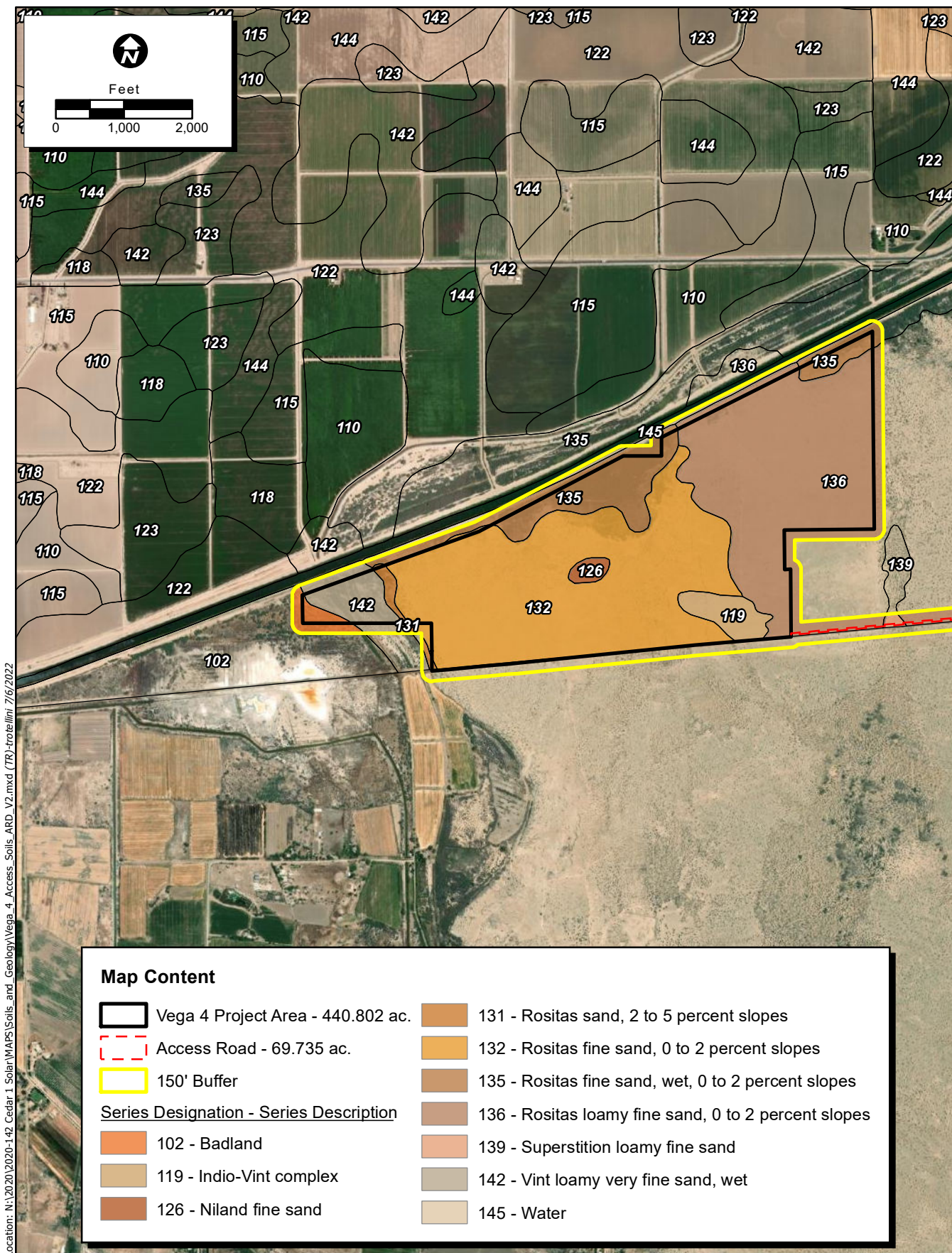
4.1.2 Soils

According to the Web Soil Survey (NRCS 2022a), twelve soil units, or types, have been mapped within the Study Area (Figure 3). Summary characteristics based on official series descriptions for each of the soil series mapped within the alignments are provided in Table 4 below (NRCS 2022a; 2022b; 2022c).

Table 4. Natural Resources Conservation Service Soil Types within the Study Area						
Map Unit Symbol	Map Unit Name	Taxonomic Class	Taxonomic Order	Drainage Class	Hydric Rating	Location
102	Badland	N/A	N/A	N/A	N/A	Solar Field
111	Holtville-Imperial silty clay loams	Clayey over loamy, montmorillonitic (calcareous), hyperthermic Typic Torrifluvents	Entisols	Well drained	No	Access Road
119	Indio-Vint complex	Coarse-silty, mixed (calcareous), hyperthermic Typic Torrifluvents	Entisols	Well drained	No	Solar Field
126	Niland fine sand	Sandy over clayey, mixed (calcareous), hyperthermic Typic Torrifluvents	Entisols	Moderately well drained	No	Solar Field
131	Rositas sand, 2 to 5 percent slopes	Mixed, hyperthermic Typic Torripsammets	Entisols	Somewhat excessively drained	No	Solar Field
132	Rositas fine sand, 0 to 2 percent slopes	Mixed, hyperthermic Typic Torripsammets	Entisols	Somewhat excessively drained	No	Solar Field, Access Road
133	Rositas fine sand, 2 to 9 percent slopes	Mixed, hyperthermic Typic Torripsammets	Entisols	Somewhat excessively drained	No	Access Road
135	Rositas fine sand, wet, 0 to 2 percent slopes	Mixed, hyperthermic Typic Torripsammets	Entisols	Moderately well drained	No	Solar Field, Access Road
136	Rositas loamy fine sand, 0 to 2 percent slopes	Mixed, hyperthermic Typic Torripsammets	Entisols	Somewhat excessively drained	No	Solar Field, Access Road
139	Superstition loamy fine sand	Sandy, mixed, hyperthermic Typic Calciorrhids	Aridisols	Somewhat excessively drained	No	Access Road
142	Vint loamy very fine sand, wet	Sandy, mixed, hyperthermic Typic Torrifluvents	Entisols	Moderately well drained	No	Solar Field
145	Water	N/A	N/A	N/A	N/A	Access Road

4.1.3 National Wetland Inventory

According to the National Wetlands Inventory (NWI, USFWS 2022a), there are two Palustrine features and two Riverine features mapped within the Study Area (Figure 4). All features correspond to aquatic features identified during the field study.



Location: N:\2020\2020-142_Cedar_1_Solar\WAPS\Soils_and_Geology\Vega_4_Access_Soils_ARL_V2.mxd (TR)-tristellini 7/6/2022

Map Date: 7/6/2022





Service Layer Credits: Source: Esri, Maxar, Earthstar Geographics, and the GIS User Community

Figure 3. Natural Resources Conservation Service Soil Types - Sheet 1 of 9

2020-142 Vega SES 4



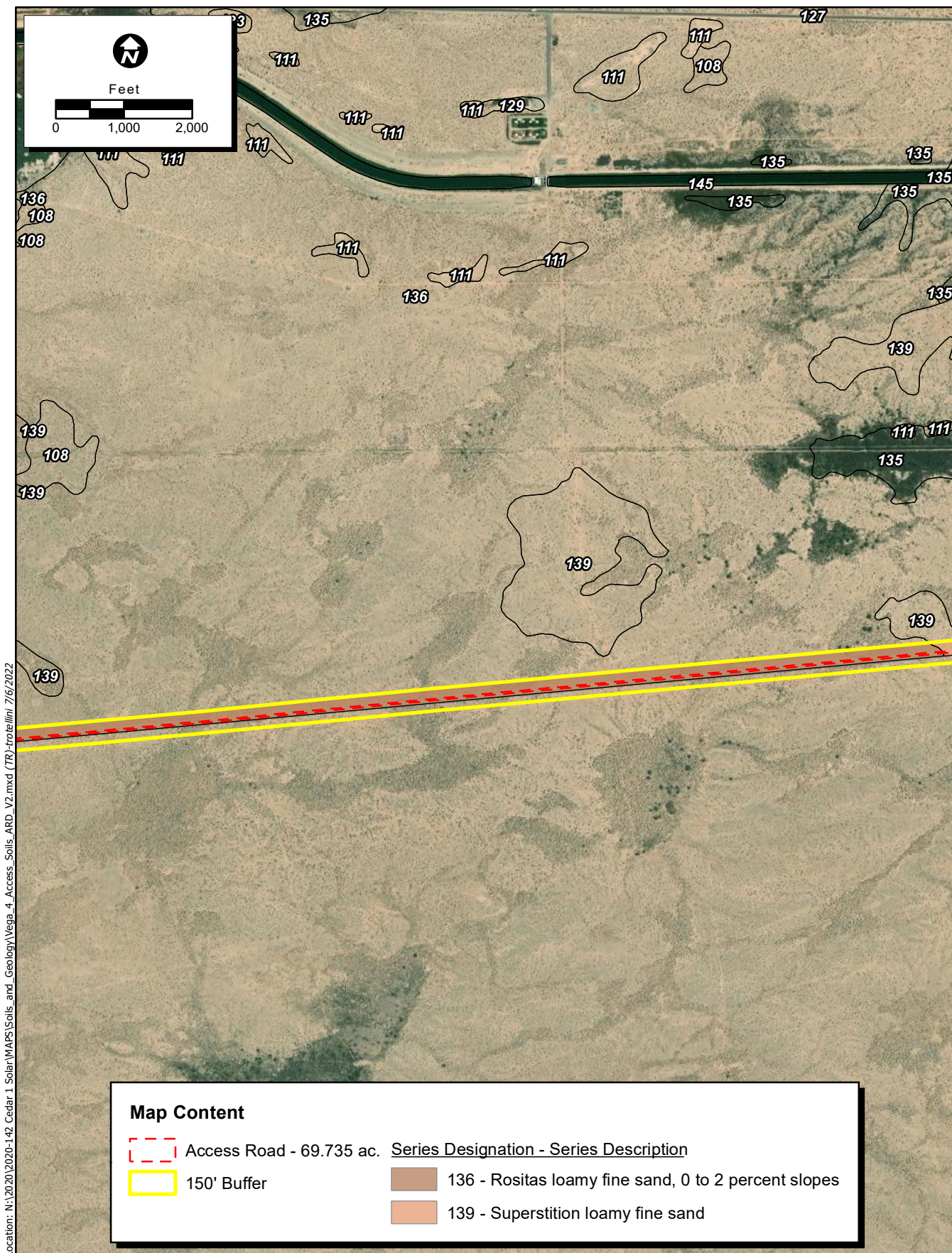
Location: N:\2020\2020-142_Cedar 1 Solar\MAPS\Soils_and_Geology\Vega_4_Access_Soils_ARD_V2.mxd (TR)-tristefani 7/6/2022

Map Content	
	Access Road - 69.735 ac. <u>Series Designation - Series Description</u>
	150' Buffer
	136 - Rositas loamy fine sand, 0 to 2 percent slopes
	139 - Superstition loamy fine sand

Map Date: 7/6/2022
 Service Layer Credits: Source: Esri, Maxar, Earthstar Geographics, and the GIS User Community

Figure 3. Natural Resources Conservation Service Soil Types - Sheet 2 of 9

2020-142 Vega SES 4



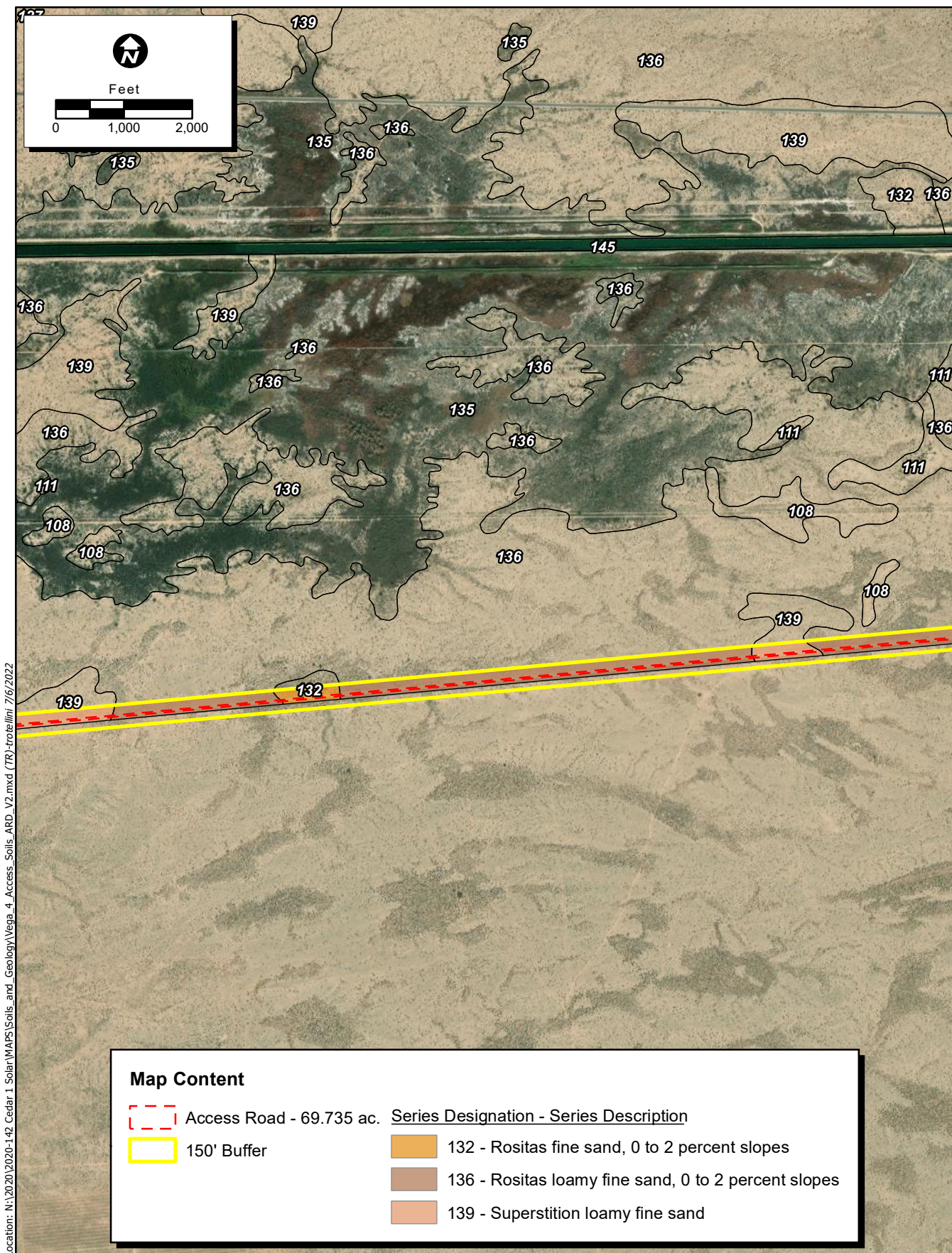
Location: N:\2020\2020-142_Cedar 1 Solar\WAPS\Soils_and_Geology\Vega_4_Access_Soils_ARD_V2.mxd (TR) - Project Date: 7/6/2022

Map Content	
	Access Road - 69.735 ac. <u>Series Designation - Series Description</u>
	150' Buffer
	136 - Rositas loamy fine sand, 0 to 2 percent slopes
	139 - Superstition loamy fine sand

Map Date: 7/6/2022
 Service Layer Credits: Source: Esri, Maxar, Earthstar Geographics, and the GIS User Community

Figure 3. Natural Resources Conservation Service Soil Types - Sheet 3 of 9

2020-142 Vega SES 4



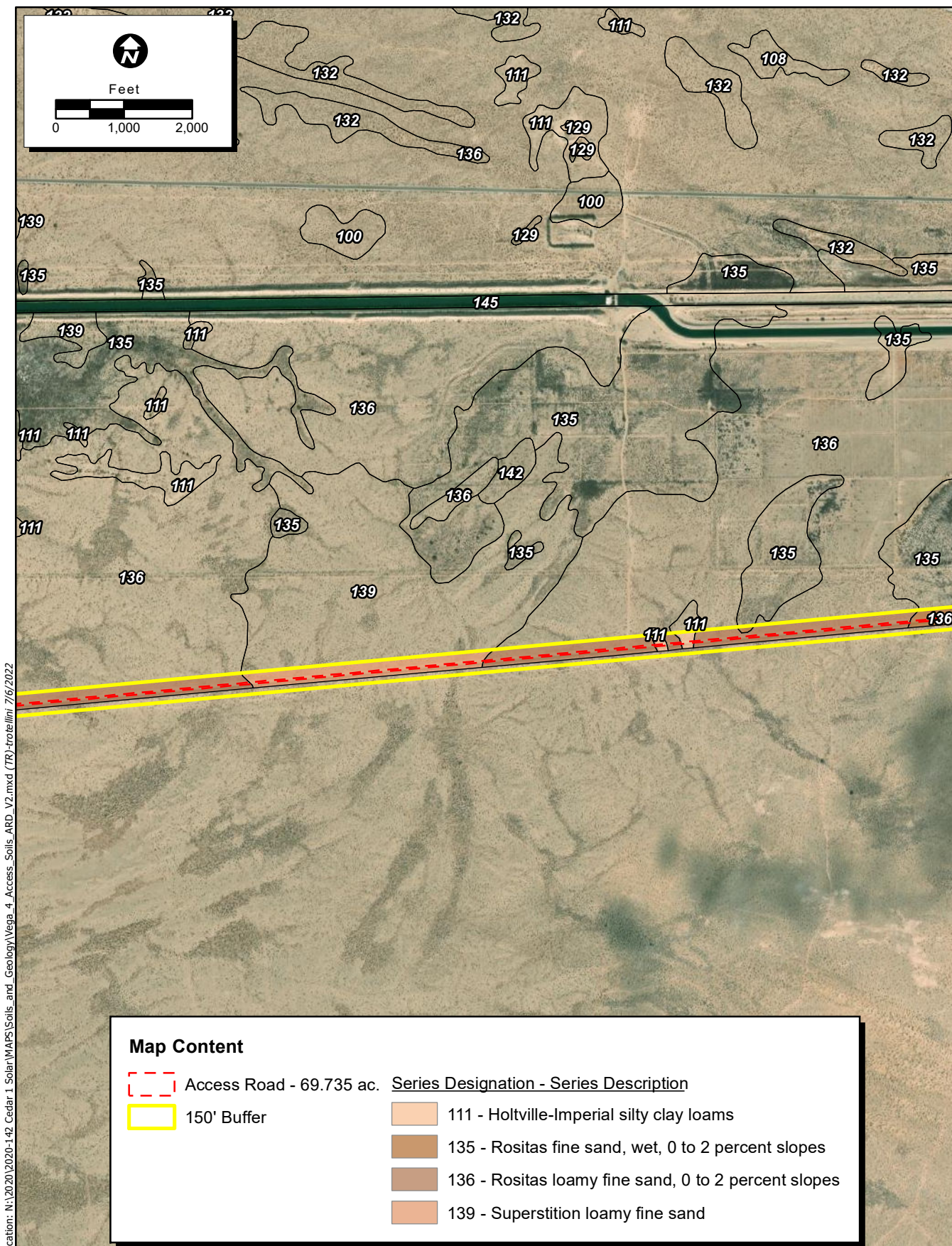
Location: N:\2020\2020-142_Cedar 1 Solar\WAPS\Soils_and_Geology\Vega_4_Access_Soils_ARD_V2.mxd (TR)-tristellini 7/6/2022

Map Date: 7/6/2022

Service Layer Credits: Source: Esri, Maxar, Earthstar Geographics, and the GIS User Community

Figure 3. Natural Resources Conservation Service Soil Types - Sheet 4 of 9

2020-142 Vega SES 4



Location: N:\2020\2020-142_Cedar 1 Solar\WAPS\Soils_and_Geology\Vega-4_Access_Soils_ARD_V2.mxd (TR)-tristefini_7/6/2022

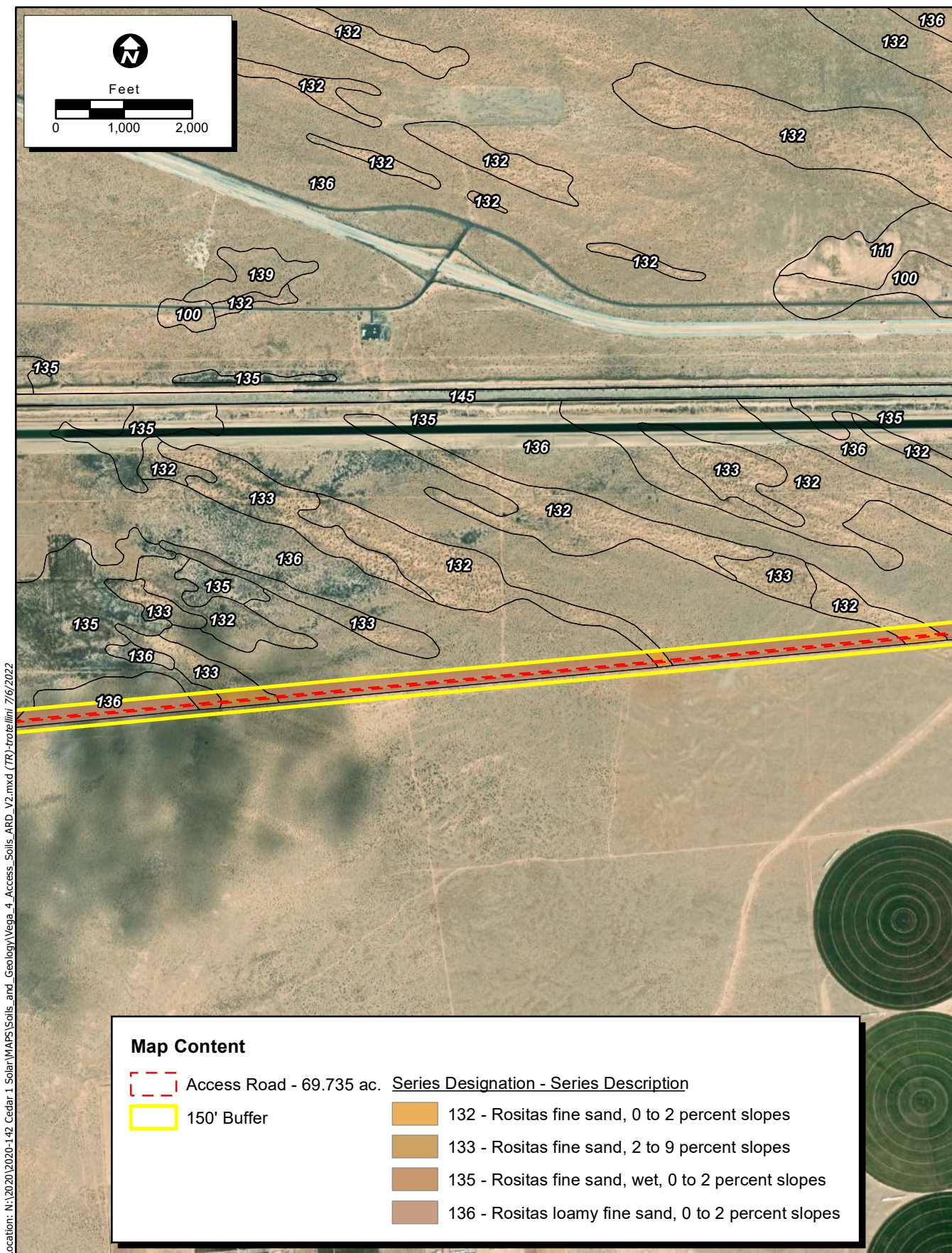
Map Content	
	Access Road - 69.735 ac.
	150' Buffer
Series Designation - Series Description	
	111 - Holtville-Imperial silty clay loams
	135 - Rositas fine sand, wet, 0 to 2 percent slopes
	136 - Rositas loamy fine sand, 0 to 2 percent slopes
	139 - Superstition loamy fine sand

Map Date: 7/6/2022

Service Layer Credits: Source: Esri, Maxar, Earthstar Geographics, and the GIS User Community

Figure 3. Natural Resources Conservation Service Soil Types - Sheet 5 of 9

2020-142 Vega SES 4



Location: N:\2020\2020-142_Cedar 1 Solar\WAPS\Soils_and_Geology\Vega_4_Access_Soils_ARD_V2.mxd (TR)-tristefini 7/6/2022

Map Content		Series Designation - Series Description	
	Access Road - 69.735 ac.		132 - Rositas fine sand, 0 to 2 percent slopes
	150' Buffer		133 - Rositas fine sand, 2 to 9 percent slopes
			135 - Rositas fine sand, wet, 0 to 2 percent slopes
			136 - Rositas loamy fine sand, 0 to 2 percent slopes





Map Date: 7/6/2022
 Service Layer Credits: Source: Esri, Maxar, Earthstar Geographics, and the GIS User Community

Figure 3. Natural Resources Conservation Service Soil Types - Sheet 6 of 9

2020-142 Vega SES 4



Location: N:\2020\2020-142_Cedar_1_Solar\MAPS\Soils_and_Geology\Vega_4_Access_Soils_ARL_V2.mxd (TR)-tristefani 7/6/2022

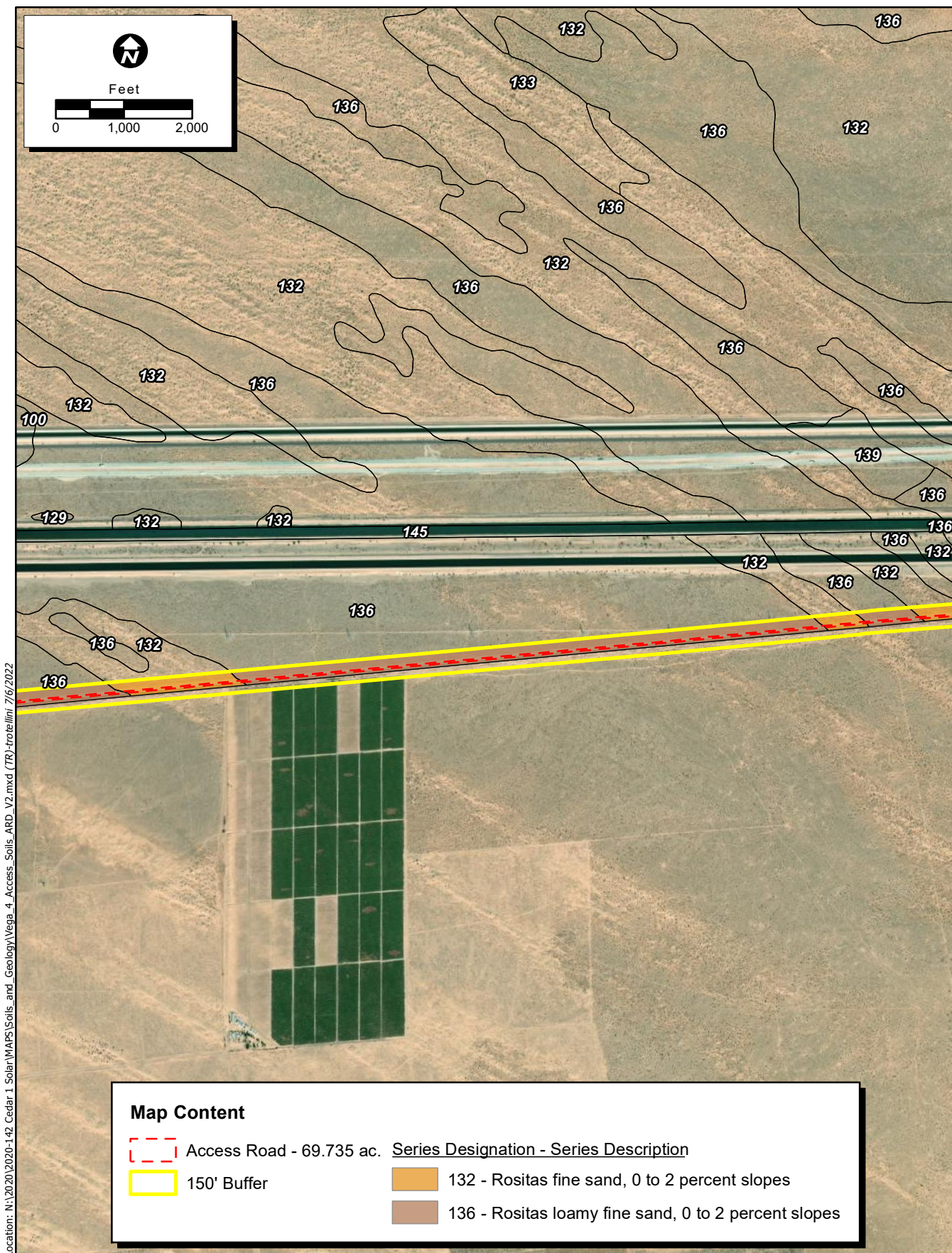
Map Content	
	Access Road - 69.735 ac. <u>Series Designation - Series Description</u>
	150' Buffer
	132 - Rositas fine sand, 0 to 2 percent slopes
	136 - Rositas loamy fine sand, 0 to 2 percent slopes

Map Date: 7/6/2022





Service Layer Credits: Source: Esri, Maxar, Earthstar Geographics, and the GIS User Community

Figure 3. Natural Resources Conservation Service Soil Types - Sheet 7 of 9

2020-142 Vega SES 4



Location: N:\2020\2020-142_Cedar 1 Solar\WAPS\Soils_and_Geology\Vega_4_Access_Soils_ARD_V2.mxd (TR)-tristefani 7/6/2022

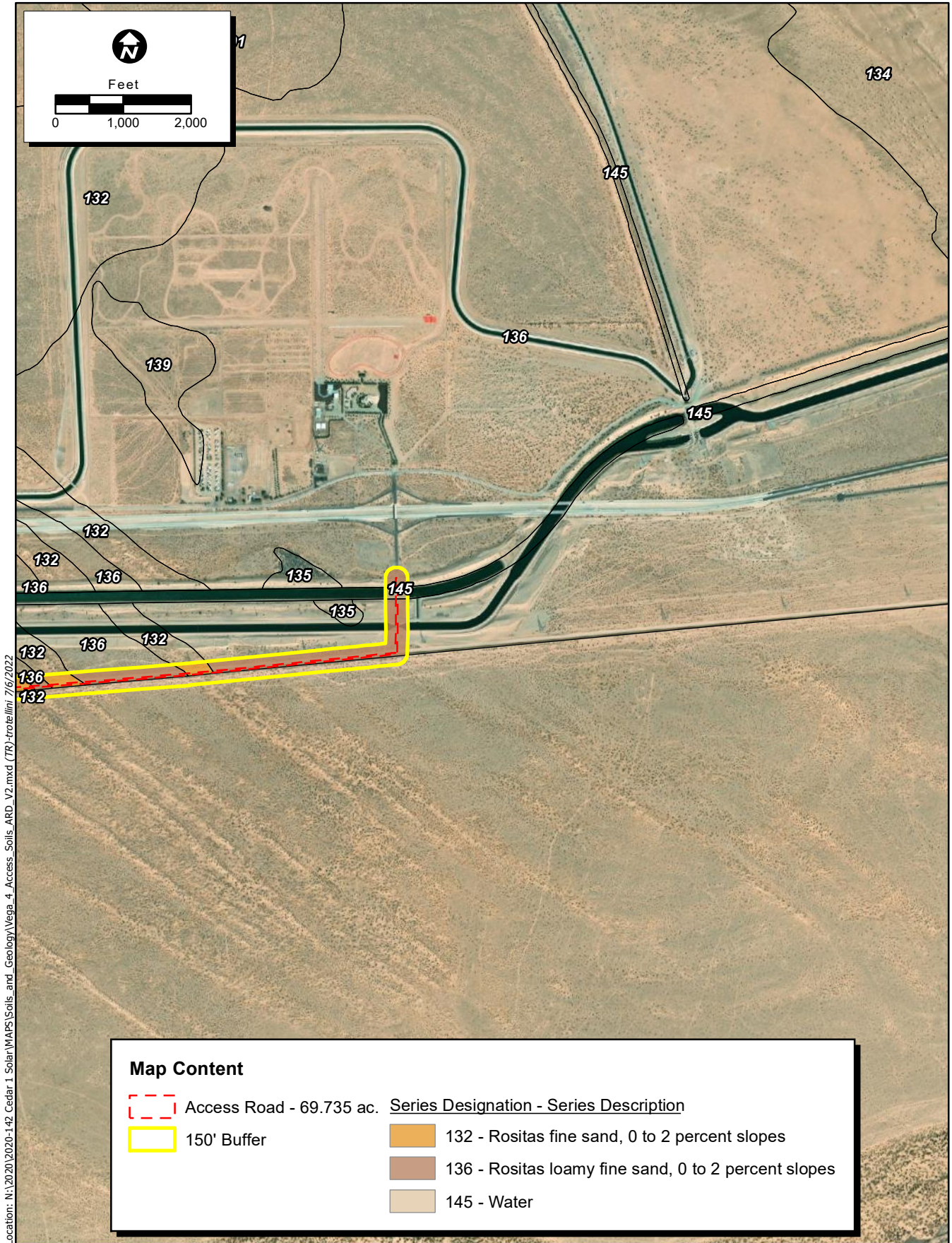
Map Content	
	Access Road - 69.735 ac. <u>Series Designation - Series Description</u>
	150' Buffer
	132 - Rositas fine sand, 0 to 2 percent slopes
	136 - Rositas loamy fine sand, 0 to 2 percent slopes

Map Date: 7/6/2022

Service Layer Credits: Source: Esri, Maxar, Earthstar Geographics, and the GIS User Community

Figure 3. Natural Resources Conservation Service Soil Types - Sheet 8 of 9

2020-142 Vega SES 4



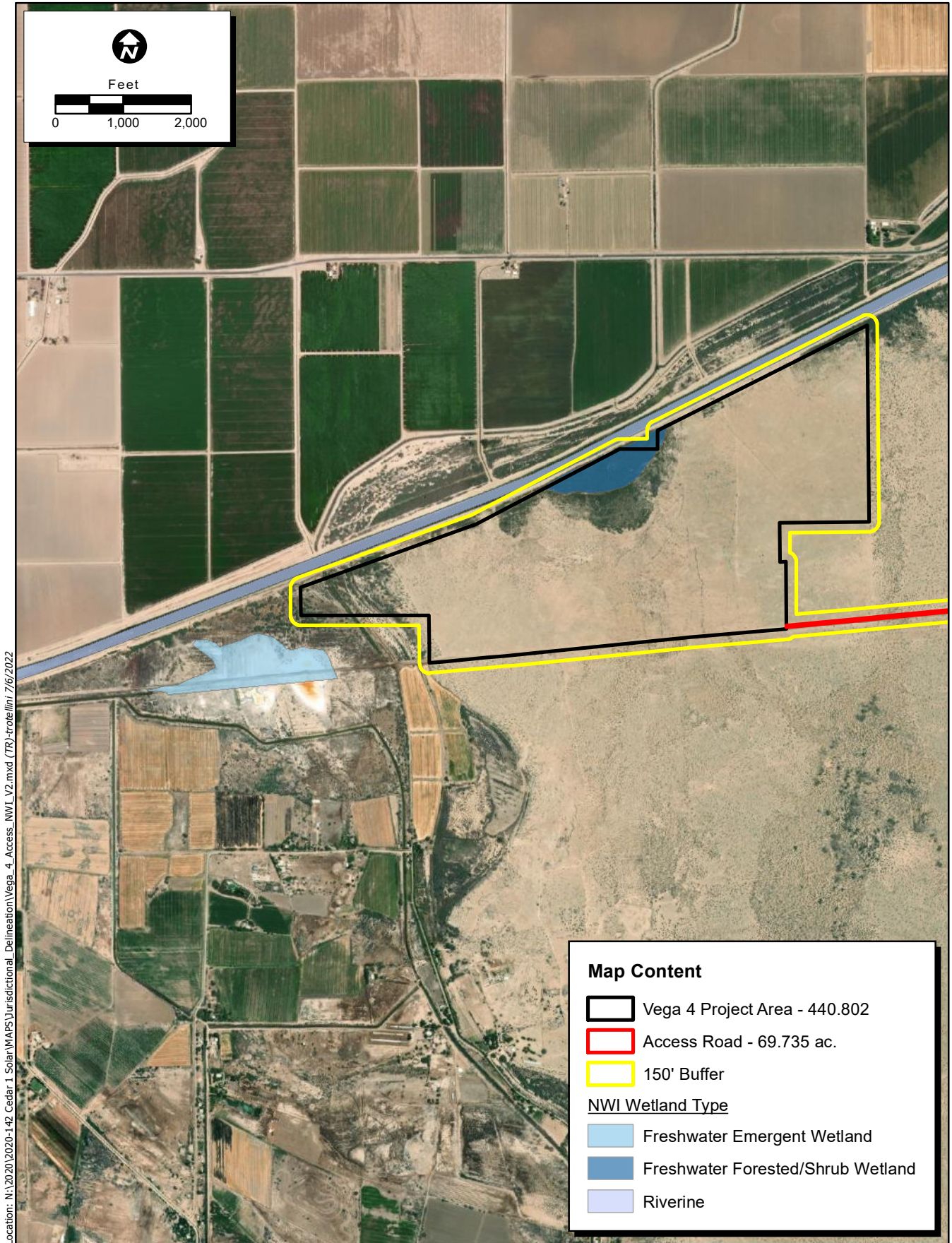
Location: N:\2020\2020-142_Cedar 1 Solar\WAPS\Soils_and_Geology\Vega_4_Access_Soils_ARD_V2.mxd (TR)-tristellini, 7/6/2022

Map Date: 7/6/2022

Service Layer Credits: Source: Esri, Maxar, Earthstar Geographics, and the GIS User Community

Figure 3. Natural Resources Conservation Service Soil Types - Sheet 9 of 9

2020-142 Vega SES 4



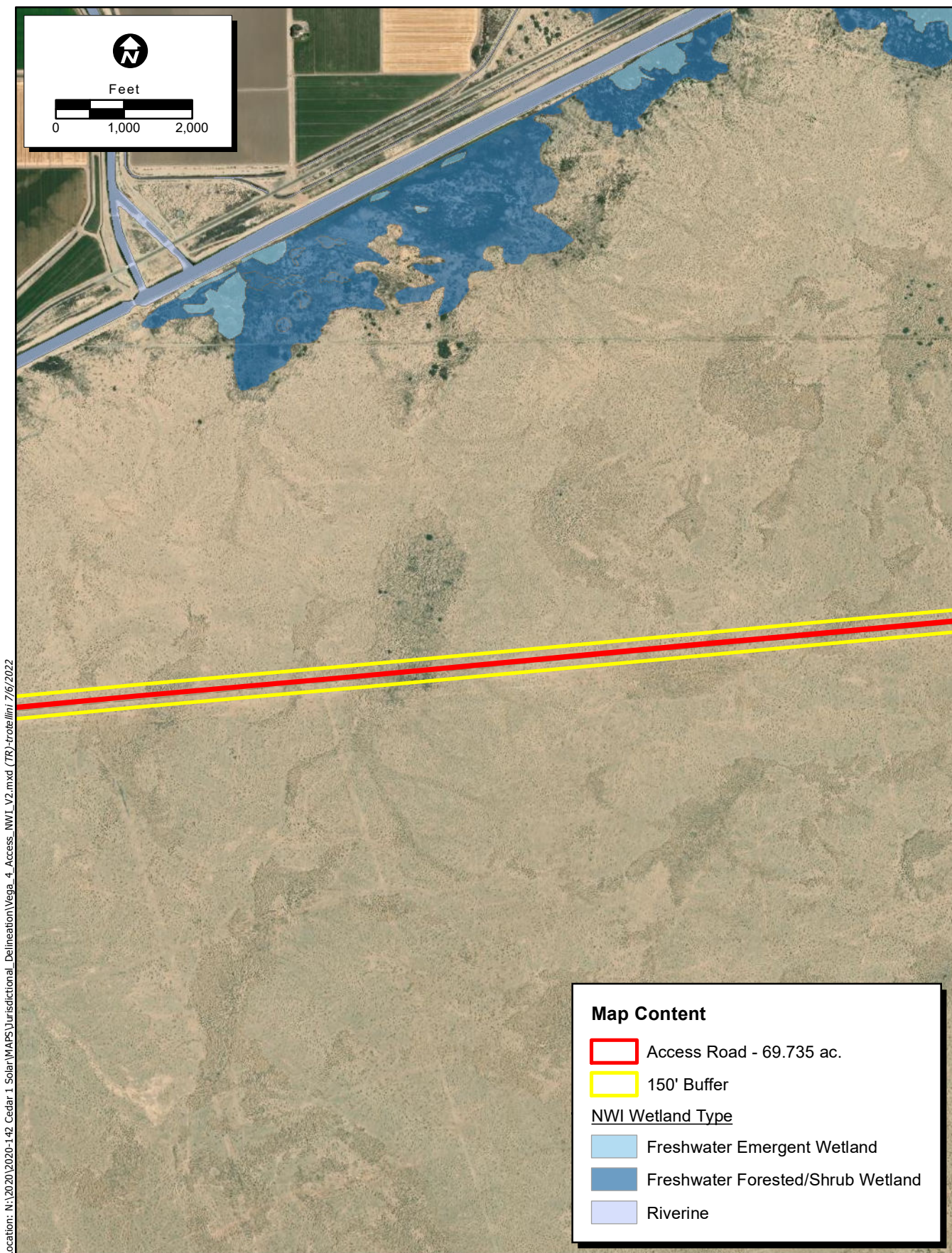
Location: N:\2020\2020-142_Cedar 1 Solar\WAPS\Jurisdictional_Delineation\Vega_4_Access_NWI_V2.mxd (TR) - created 7/6/2022

Map Date: 7/6/2022

Service Layer Credits: Source: Esri, Maxar, Earthstar Geographics, and the GIS User Community

**Figure 4. National Wetlands Inventory
Sheet 1 of 9**

2020-142 Vega SES 4



Location: N:\2020\2020-142_Cedar 1 Solar\WAPS\Jurisdictional_Delineation\Vega_4_Access_NWI_V2.mxd (TR) created 7/6/2022

Map Content

- Access Road - 69.735 ac.
- 150' Buffer

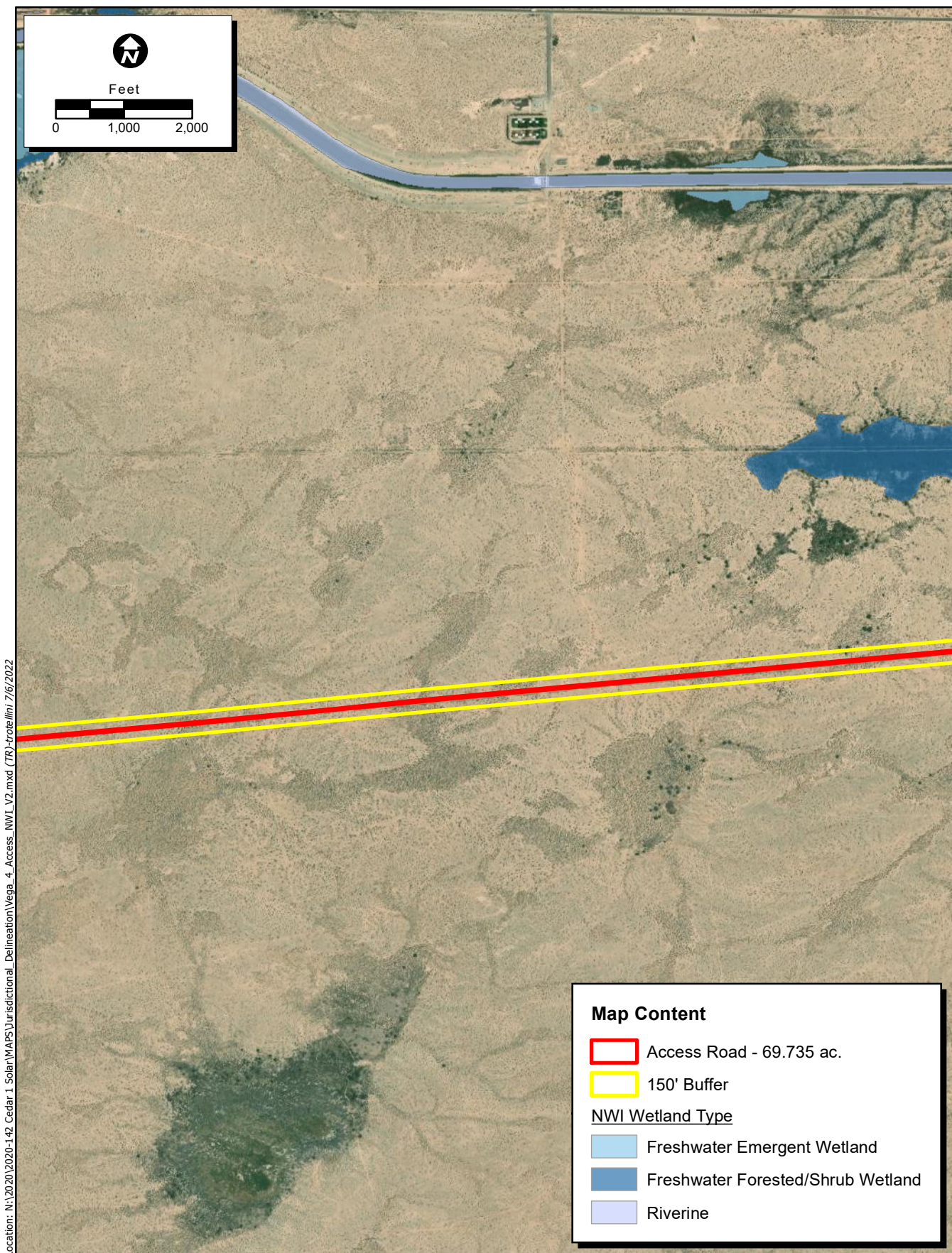
NWI Wetland Type

- Freshwater Emergent Wetland
- Freshwater Forested/Shrub Wetland
- Riverine

Map Date: 7/6/2022
 Service Layer Credits: Source: Esri, Maxar, Earthstar Geographics, and the GIS User Community

Figure 4. National Wetlands Inventory
Sheet 2 of 9

2020-142 Vega SES 4



Location: N:\2020\2020-142_Cedar 1 Solar\WAPS\Jurisdictional_Delineation\Vega_4_Access_NWI_V2.mxd (TR) - created 7/6/2022

Map Content

- Access Road - 69.735 ac.
- 150' Buffer

NWI Wetland Type

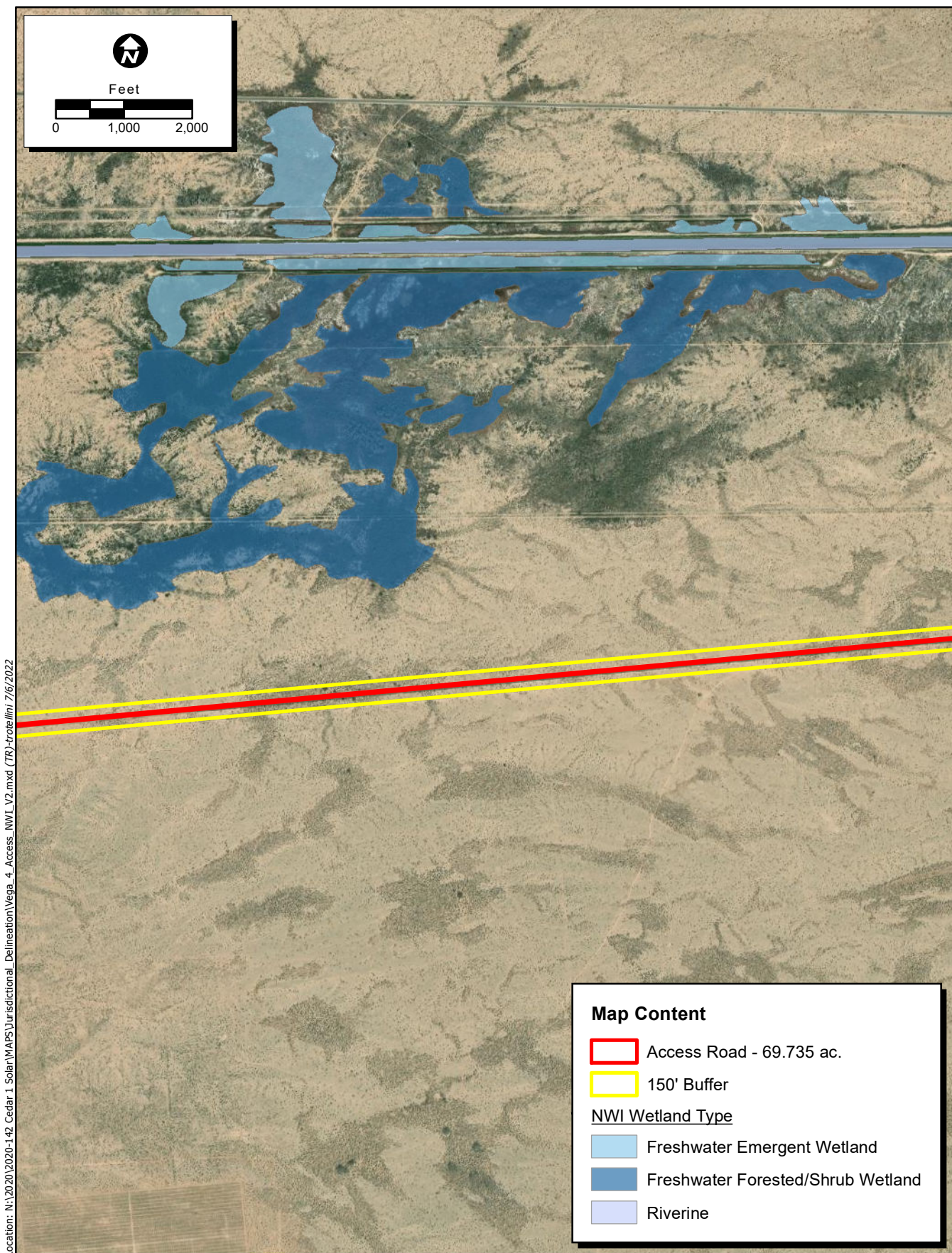
- Freshwater Emergent Wetland
- Freshwater Forested/Shrub Wetland
- Riverine

Map Date: 7/6/2022

Service Layer Credits: Source: Esri, Maxar, Earthstar Geographics, and the GIS User Community

**Figure 4. National Wetlands Inventory
Sheet 3 of 9**

2020-142 Vega SES 4



Location: N:\2020\2020-142_Cedar 1 Solar\WAPS\Jurisdictional_Delineation\Vega_4_Access_NWI_V2.mxd (TRY) created 7/6/2022

Map Content

- Access Road - 69.735 ac.
- 150' Buffer

NWI Wetland Type

- Freshwater Emergent Wetland
- Freshwater Forested/Shrub Wetland
- Riverine

Map Date: 7/6/2022

Service Layer Credits: Source: Esri, Maxar, Earthstar Geographics, and the GIS User Community

**Figure 4. National Wetlands Inventory
Sheet 4 of 9**

2020-142 Vega SES 4

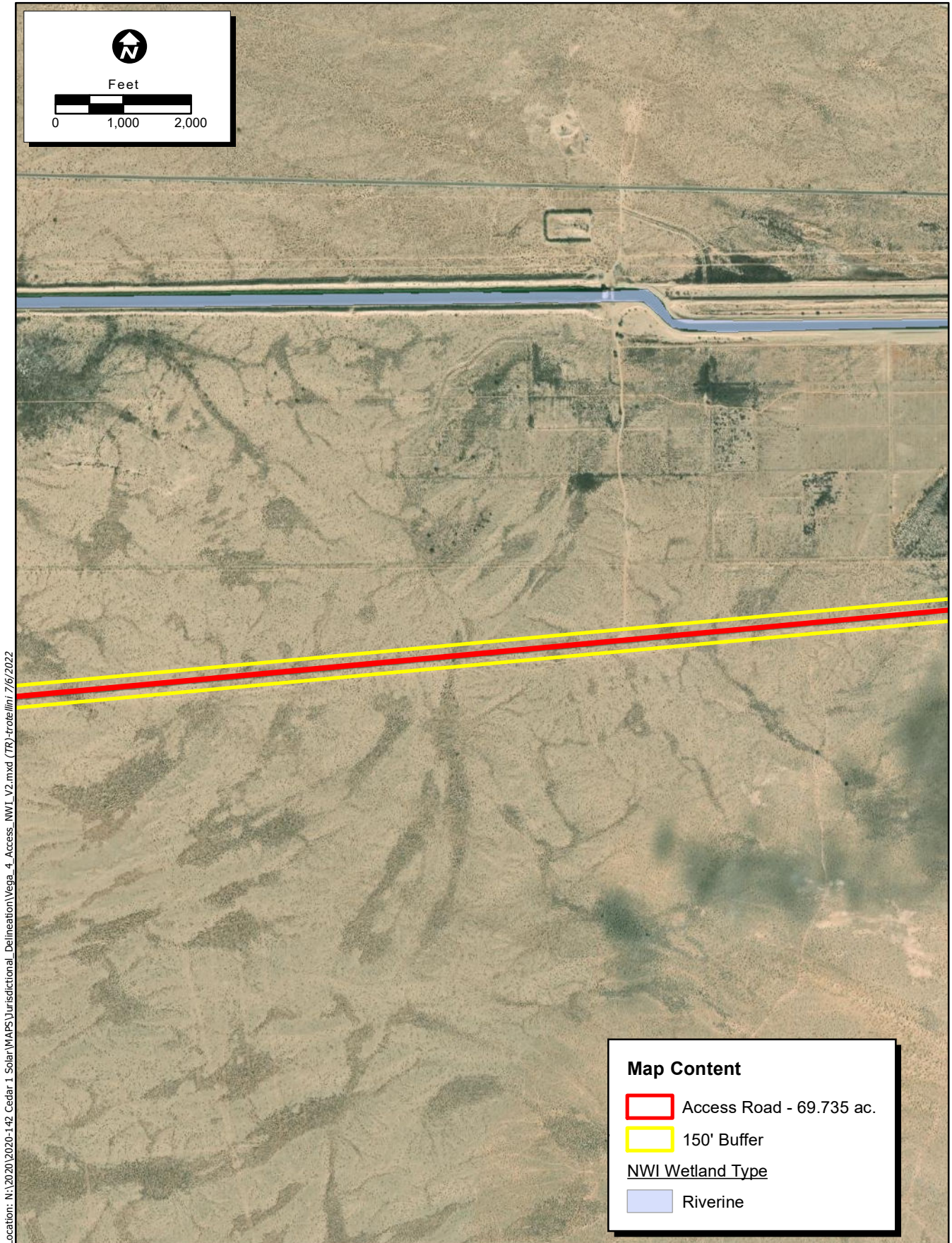


Figure 4. National Wetlands Inventory
Sheet 5 of 9

2020-142 Vega SES 4

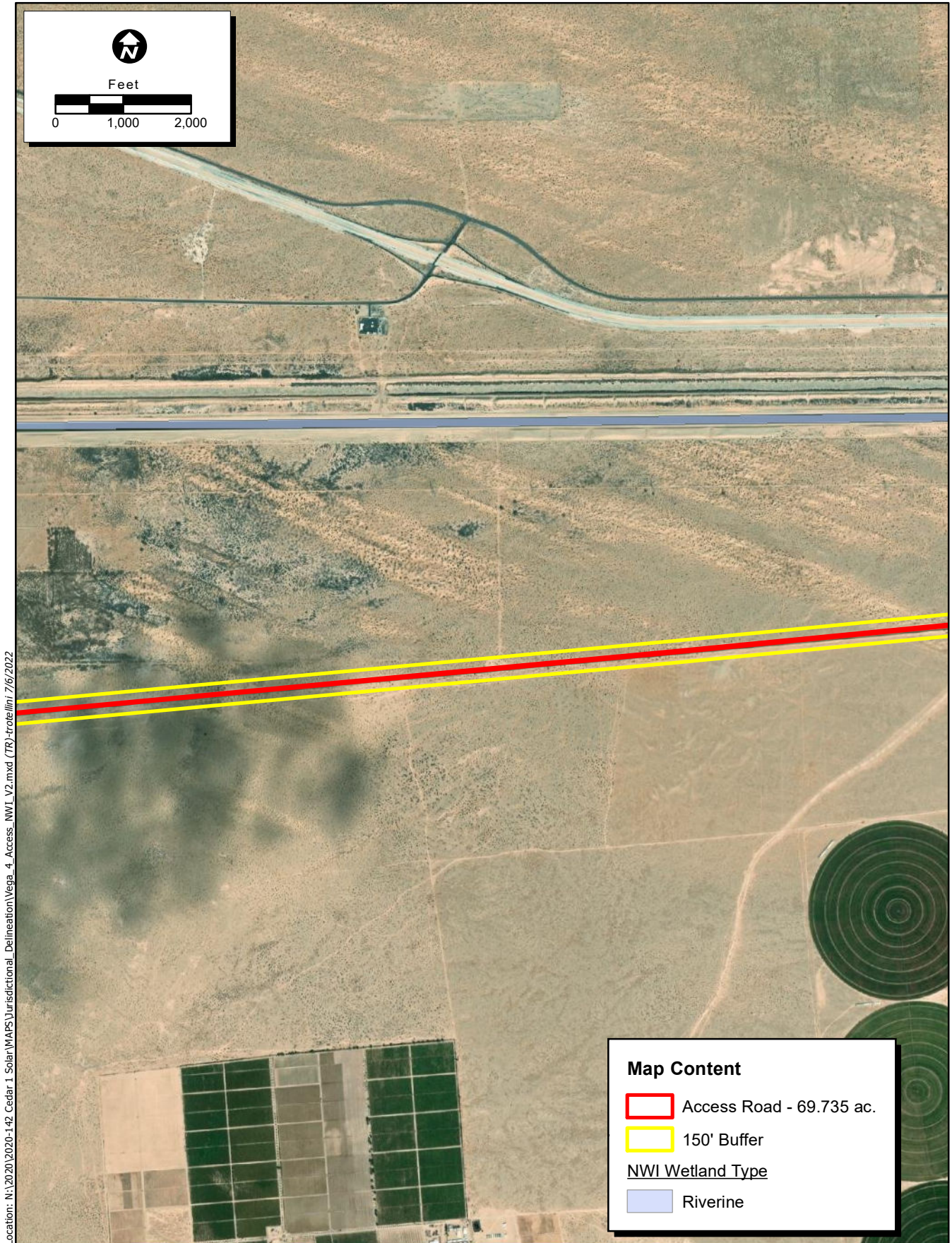
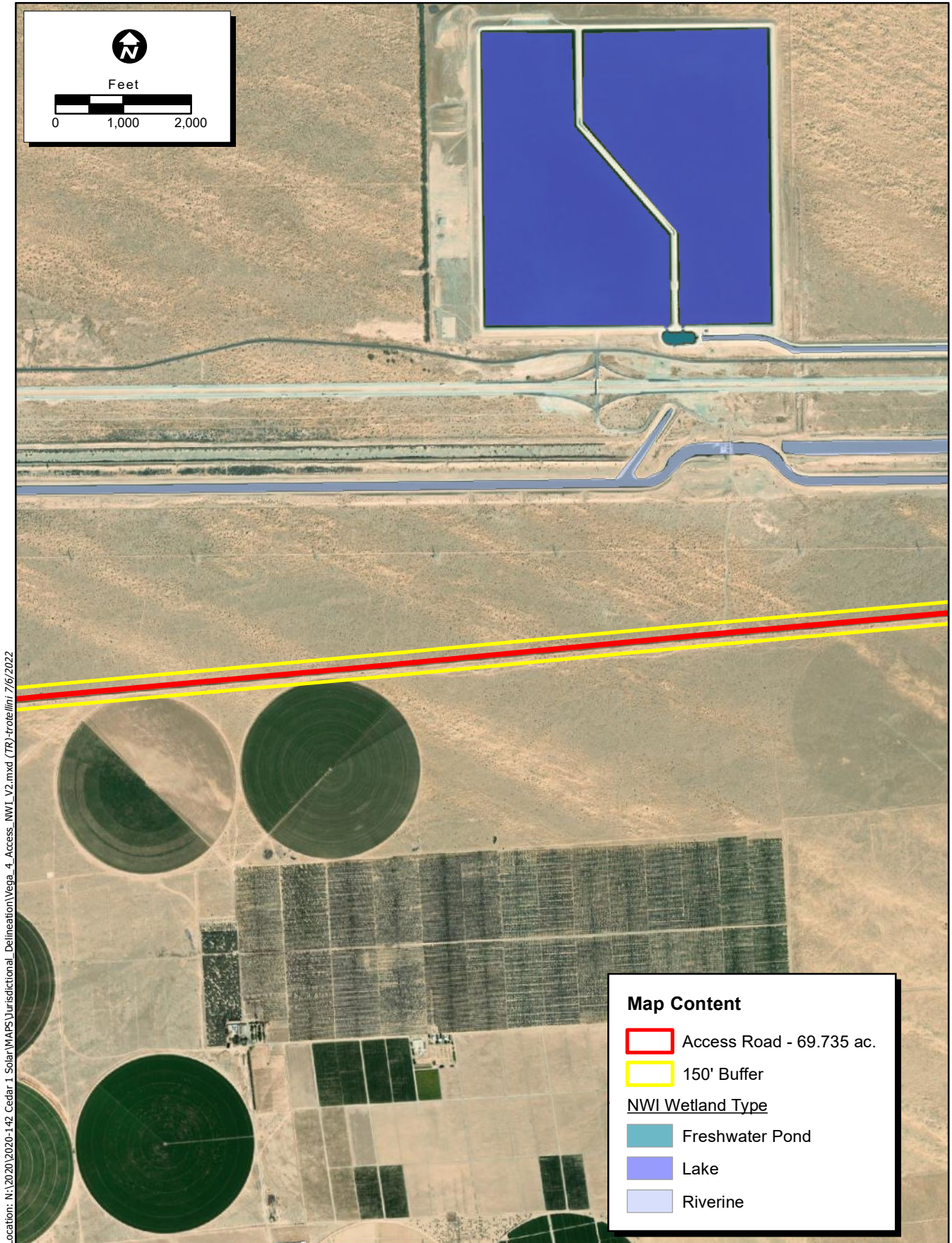


Figure 4. National Wetlands Inventory
Sheet 6 of 9

2020-142 Vega SES 4



Location: N:\2020\2020-142_Cedar 1 Solar\WAPS\Jurisdictional_Delineation\Vega_4_Access_NWI_V2.mxd (TR) - created 7/6/2022

Map Date: 7/6/2022

Service Layer Credits: Source: Esri, Maxar, Earthstar Geographics, and the GIS User Community

Figure 4. National Wetlands Inventory
Sheet 7 of 9

2020-142 Vega SES 4



Location: N:\2020\2020-142_Cedar 1 Solar\WAPS\Jurisdictional_Delineation\Vega_4_Access_NWI_V2.mxd (TR) - created 7/6/2022

Map Date: 7/6/2022

Service Layer Credits: Source: Esri, Maxar, Earthstar Geographics, and the GIS User Community

Map Content	
	Access Road - 69.735 ac.
	150' Buffer
NWI Wetland Type	
	Riverine

Figure 4. National Wetlands Inventory
Sheet 8 of 9

2020-142 Vega SES 4



Location: N:\2020\2020-142_Cedar 1 Solar\WAPS\Jurisdictional_Delineation\Vega_4_Access_NWI_V2.mxd (TR) - created 7/6/2022

Map Date: 7/6/2022

Service Layer Credits: Source: Esri, Maxar, Earthstar Geographics, and the GIS User Community

**Figure 4. National Wetlands Inventory
Sheet 9 of 9**

2020-142 Vega SES 4

4.1.4 Hydrology

The Study Area is within the Salton Sea watershed (Hydrologic Unit Code [HUC] #18100204) and within the Ash Main Canal-Alamo River (HUC-12 #181002040802), Gordons Well (HUC-12 #181002040402), and Grays Well (HUC-12 #181002040701) subwatersheds (NRCS, et al. 2022). The Study Area is downslope of the All-American Canal, which transports water from the Colorado River at the Imperial Dam and subsequently supplies it to the Imperial Valley through smaller lateral canals, all of which ultimately drain to the Salton Sea. The Salton Sea is a Traditional Navigable Water (TNW) per Section 404 of the CWA (USACE 2001).

Runoff from adjacent agricultural land collects and is concentrated in the solar field portion of the Study Area. Runoff within the planned solar field generally flows south from the direction of the All-American Canal, toward the U.S.-Mexico border, and eventually drains into a playa located west of the Project. Manmade berms running north-south line ephemeral drainages present throughout the western portion of the planned solar field. The All-American Canal and groundwater seepage likely feed the drainages and wetlands present onsite. This historical system dates back as early as 1953 (Nationwide Environmental Title Research Online [NETROnline] 2022) and is possibly remnant of a historic lakebed belonging to Lake Cahuilla.

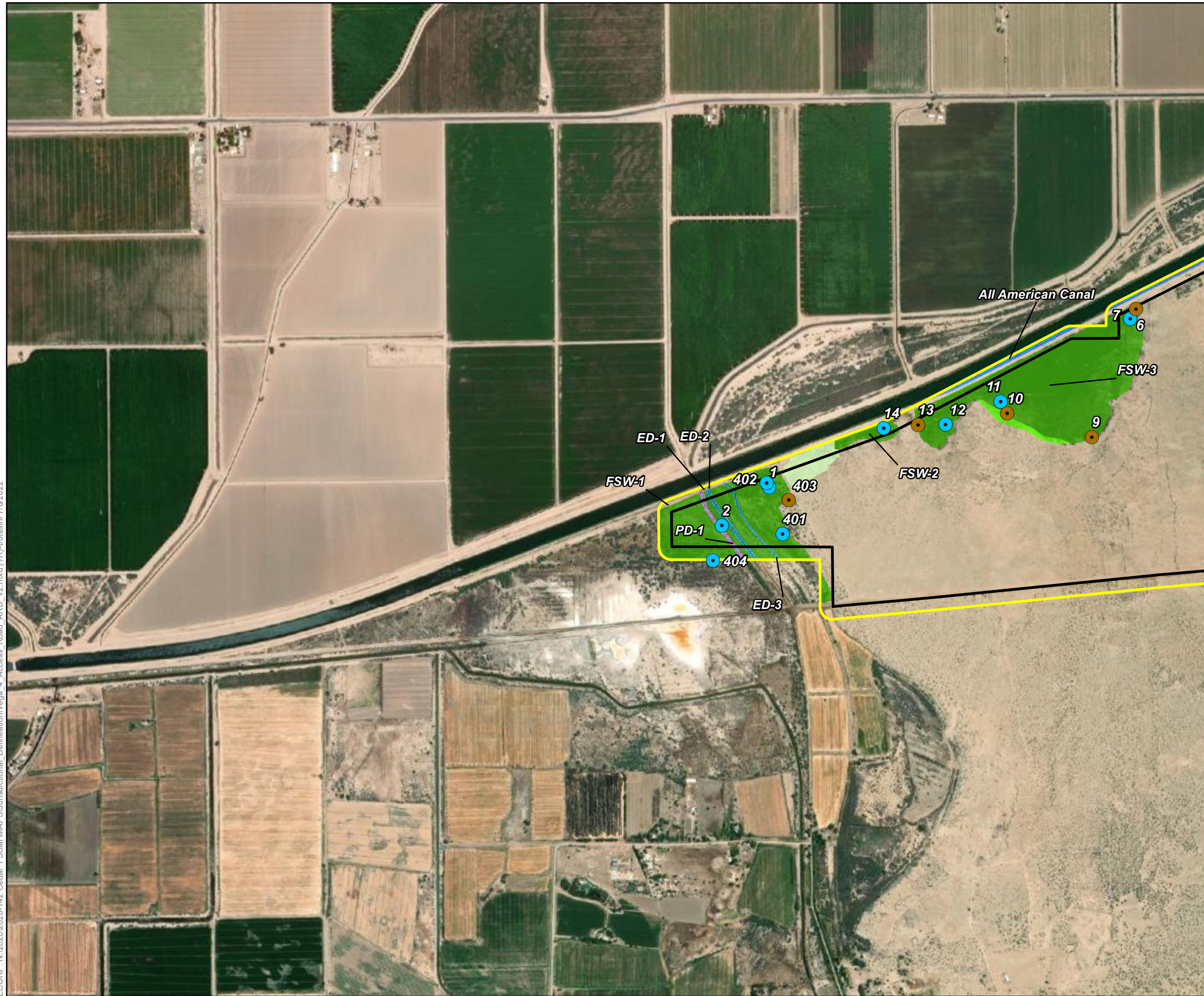
The access road runs parallel to the U.S./Mexico border and is heavily trafficked by U.S. Border Patrol vehicles. One large NWI-mapped wetland system is located approximately 0.25 mile north of the access road, and what appears to be a second wetland system is located approximately 0.10 miles north of the access road. Both wetland systems are assumed to be supported by overlapping NHD-mapped ephemeral streams (USGS 2022) and are possibly remnant of a historic lakebed belonging to Lake Cahuilla. Directly adjacent to the access road, there are two areas of riparian habitat that appear to be remnant wetlands based on the density of dead tamarisk and presence of arrow weed. Both remnant wetlands connect to what is assumed to be an active wetland located directly to the north, and it is likely these remnant wetlands were at one point fed by this active system. Both the active and remnant systems appear in historic aerials dating as far back as 1985 (NETROnline 2022).

4.2 Aquatic Resources

Aquatic resources have been mapped within the Study Area; these results are subject to agency verification. Aquatic resources that fall within the Project boundaries are summarized by feature in Table 5 and depicted on Figure 5.

Features identified as an aquatic resource had wetland indicators present and/or physical evidence of flow including OHWM, defined bed and bank, presence of a clear and natural line impressed on the bank, the presence or absence of sediment deposits, litter/debris, and/or exposed roots indicating active hydrology within the channel. Associated riparian habitat identified within the Study Area consisted of hydrophytic vegetation and hydrological indicators but lacked hydric soil indicators. The OHWM and wetland determination data forms are included as Attachment B, representative site photographs are included as Attachment C, and the USACE Operations and Maintenance Business Information Link Regulatory Module (ORM) aquatic resources table is included as Attachment D.

ECORP: N:\2020\2020-142 Cedar 1 Solar\MAPS\Jurisdictional Delineation\Vega 4_Access_Road_ARD_V2.mxd (TR)-rotellini 7/6/2022



Map Features

- Vega 4 Project Area - 440.802
- 150' Buffer
- Upland Point
- Waters Point

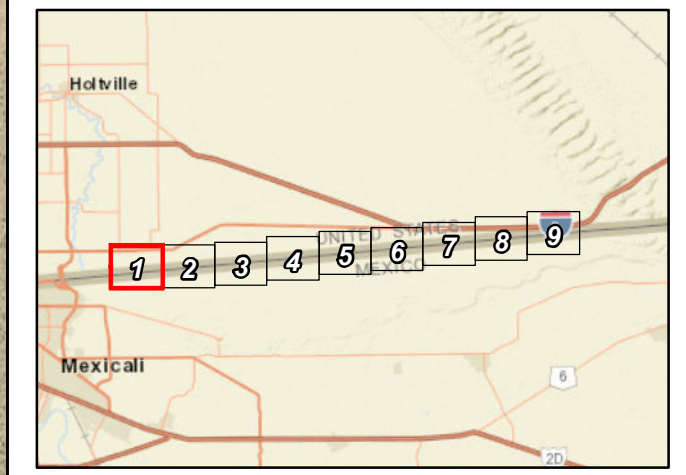
CDFW-Regulated Habitat

- Disturbed Riparian Habitat
- Riparian Habitat

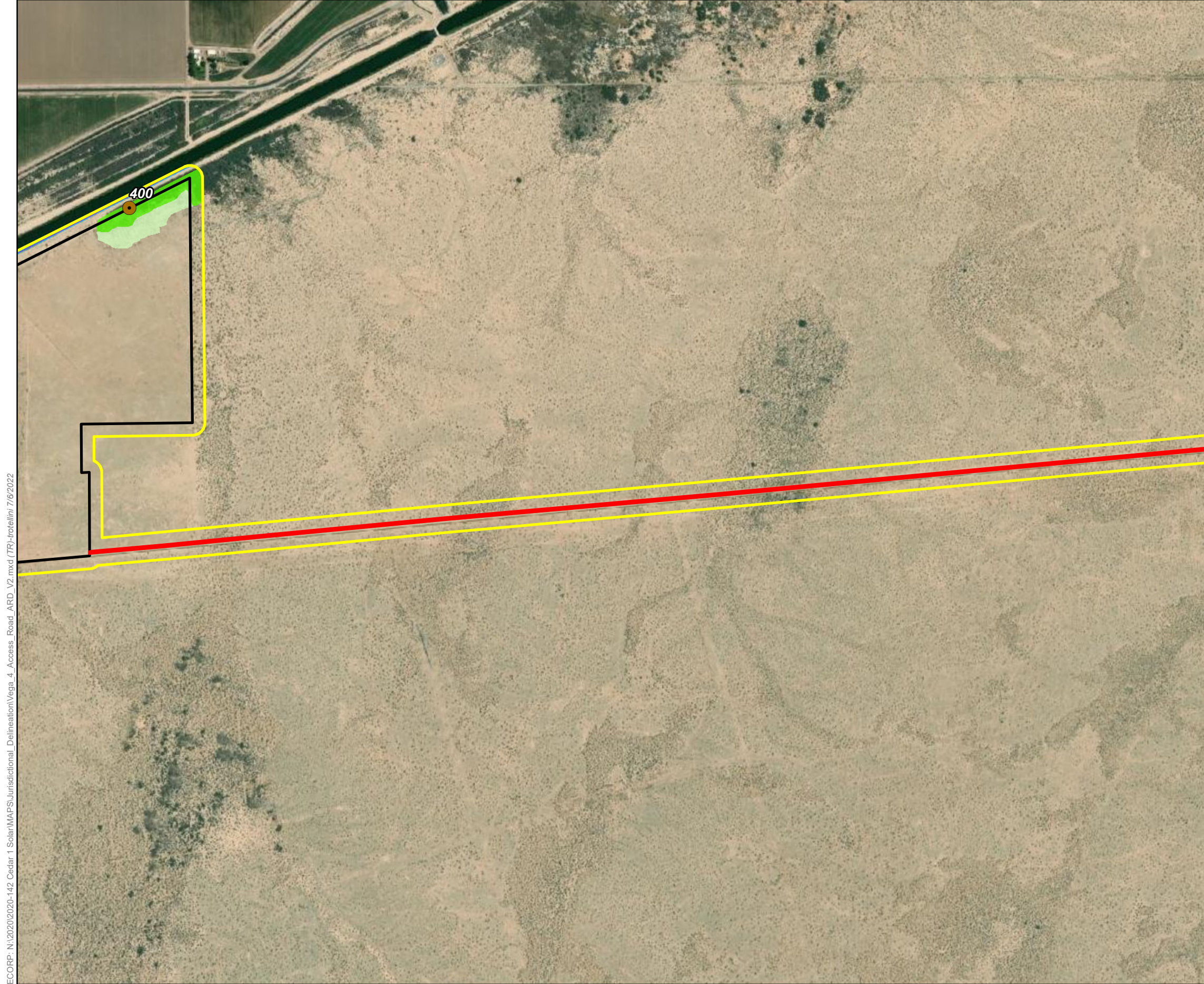
Aquatic Resources

- Canal - Bank-to-Bank (No Impacts)
- Canal - OHWM (No Impacts)
- Perennial Drainage - Bank-to-Bank
- Perennial Drainage - OHWM
- Ephemeral Drainage - Bank-to-Bank
- Ephemeral Drainage - OHWM
- Forested Shrub Wetland

Service Layer Credits: Sources: Esri, HERE, Garmin, USGS, Intermap, INCREMENT P, NRCan, Esri Japan, METI, Esri China (Hong Kong), Esri Korea, Esri (Thailand), NGCC, (c) OpenStreetMap contributors, and the GIS User Community



Map Date: 7/6/2022



- Map Features**
- Vega 4 Project Area - 440.802
 - Access Road - 69.735 ac.
 - 150' Buffer
 - Upland Point
- CDFW-Regulated Habitat**
- Disturbed Riparian Habitat
 - Riparian Habitat
- Aquatic Resources**
- Canal - Bank-to-Bank (No Impacts)
 - Canal - OHWM (No Impacts)

ECORP: N:\2020\2020-142 Cedar 1 Solar\MAPS\Jurisdictional_Delineation\Vega_4_Access_Road_ARC_V2.mxd (TR)-rotellini 7/6/2022

Service Layer Credits: Sources: Esri, HERE, Garmin, USGS, Intermap, INCREMENT P, NRCan, Esri Japan, METI, Esri China (Hong Kong), Esri Korea, Esri (Thailand), NGCC, (c) OpenStreetMap contributors, and the GIS User Community

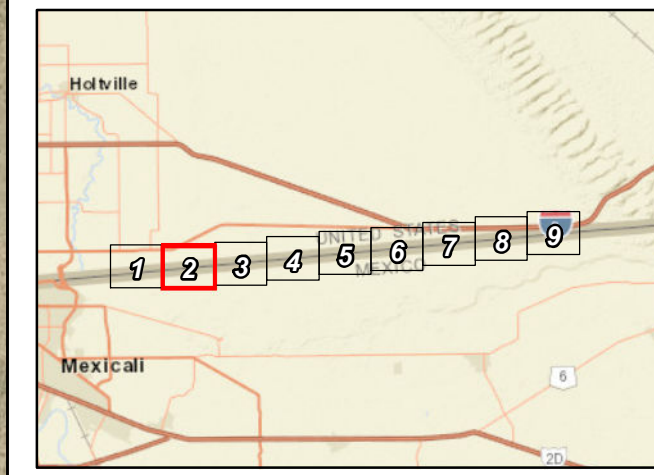
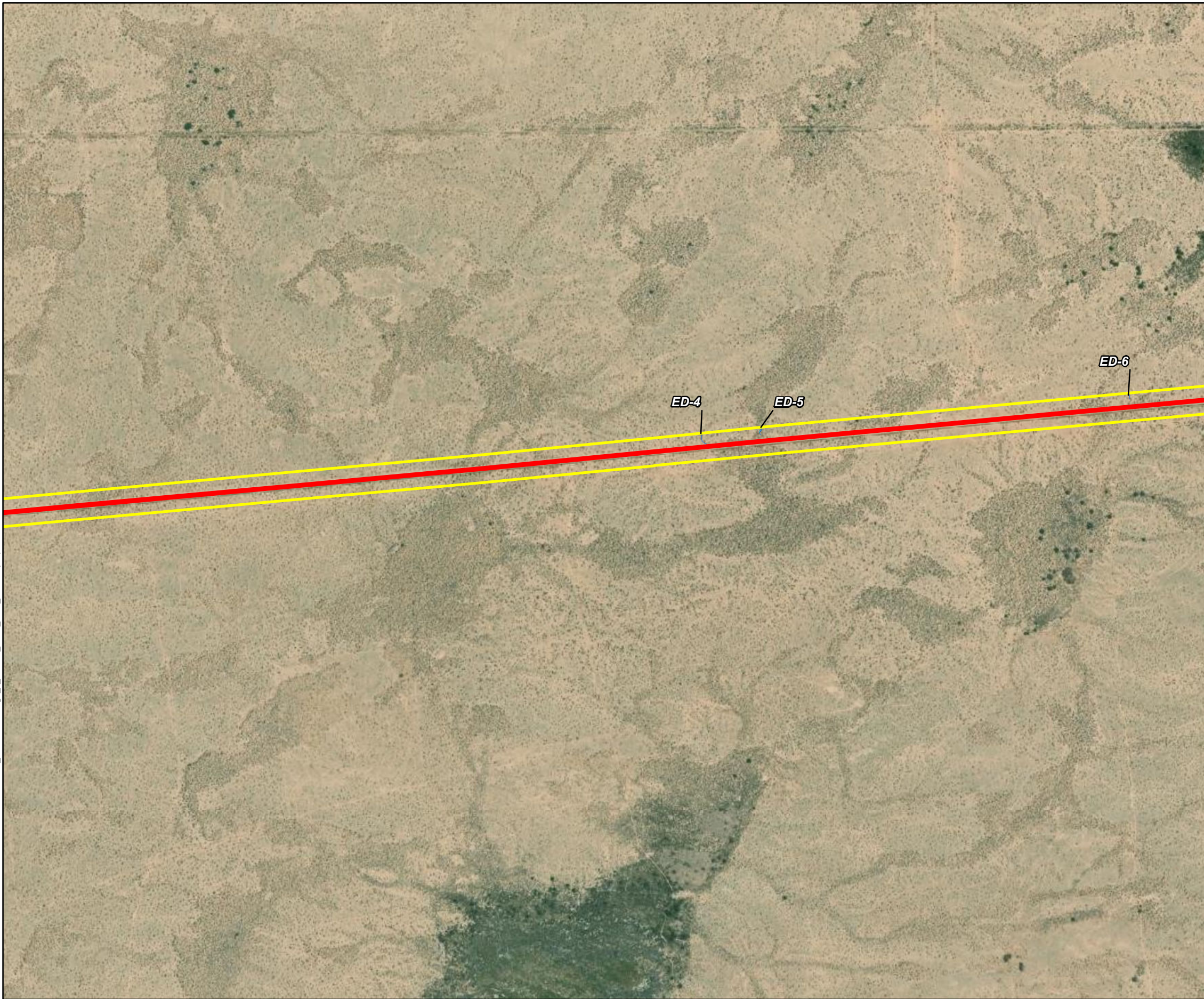


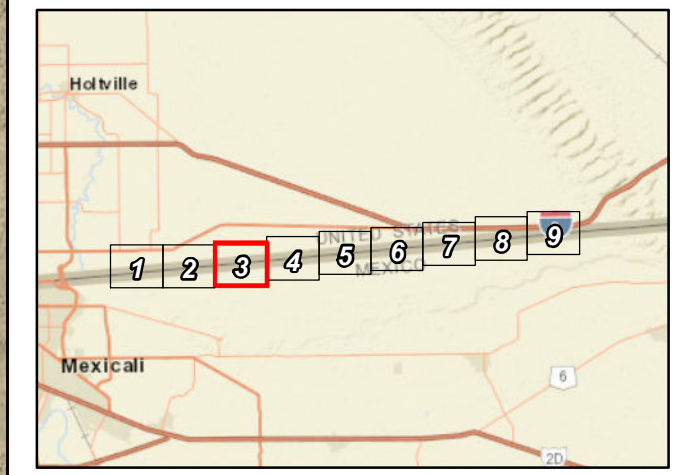
Figure 5. Aquatic Resources Delineation
Sheet 2 of 9
 2020-142 Vega SES 4

ECORP: N:\2020\2020-142 Cedar 1 Solar\MAPS\Jurisdictional_Delineation\Vega_4_Access_Road_ARC_V2.mxd (TR)-trotellini 7/6/2022



- Map Features**
- Access Road - 69.735 ac.
 - 150' Buffer
- Aquatic Resources**
- Ephemeral Drainage - Bank-to-Bank
 - Ephemeral Drainage - OHWM

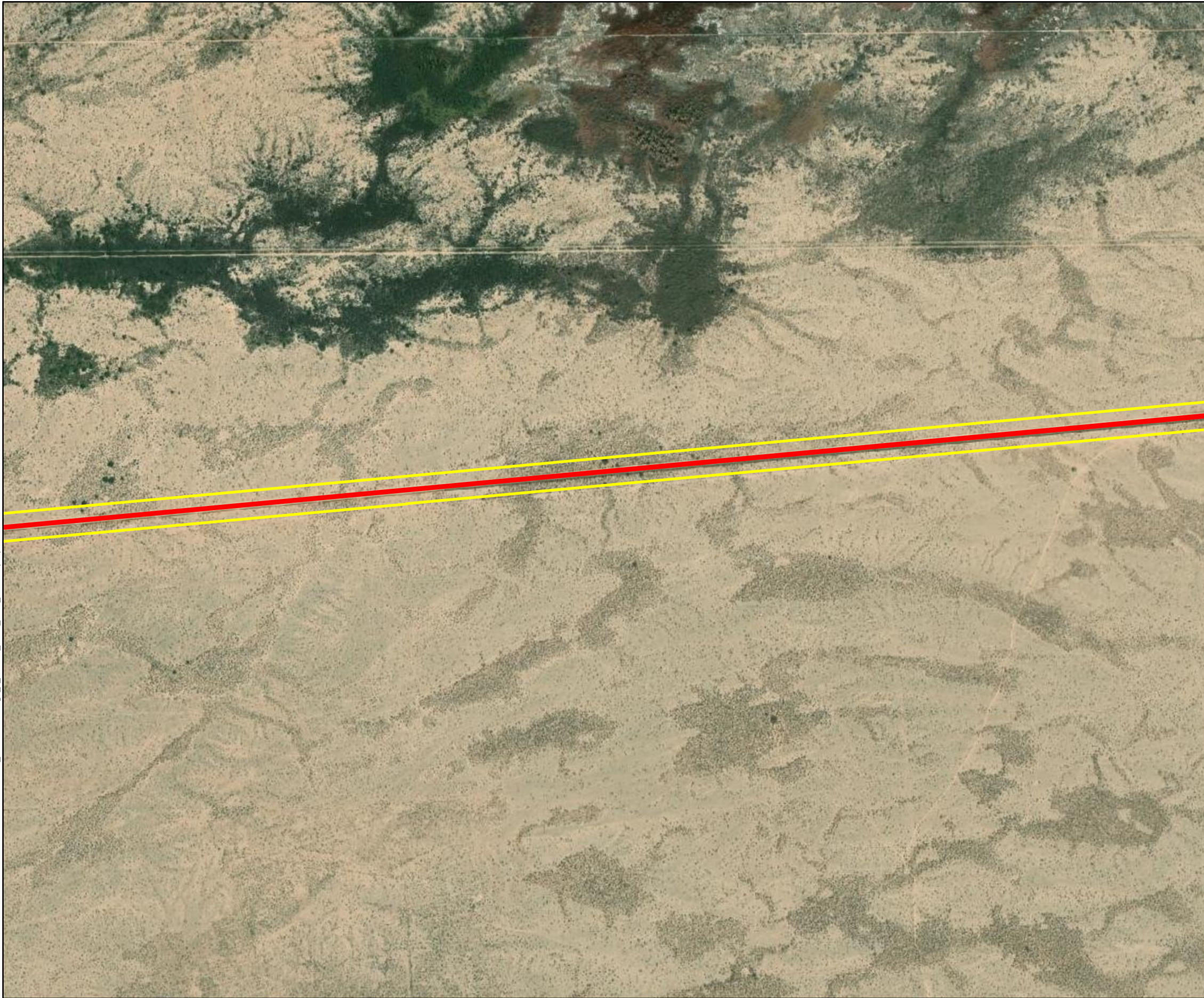
Service Layer Credits: Sources: Esri, HERE, Garmin, USGS, Intermap, INCREMENT P, NRCan, Esri Japan, METI, Esri China (Hong Kong), Esri Korea, Esri (Thailand), NGCC, (c) OpenStreetMap contributors, and the GIS User Community





Map Date: 7/6/2022



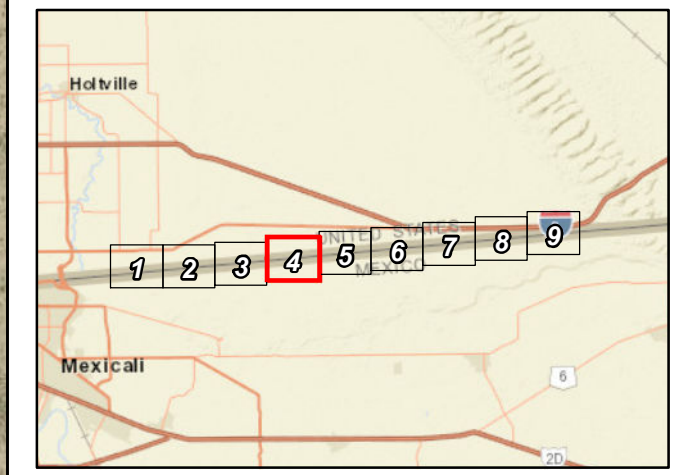
ECORP: N:\2020\2020-142 Cedar 1 Solar\MAPS\Jurisdictional Delineation\Vega_4_Access_Road_ARD_V2.mxd (TR)-rotellini 7/6/2022



Map Features

-  Access Road - 69.735 ac.
-  150' Buffer

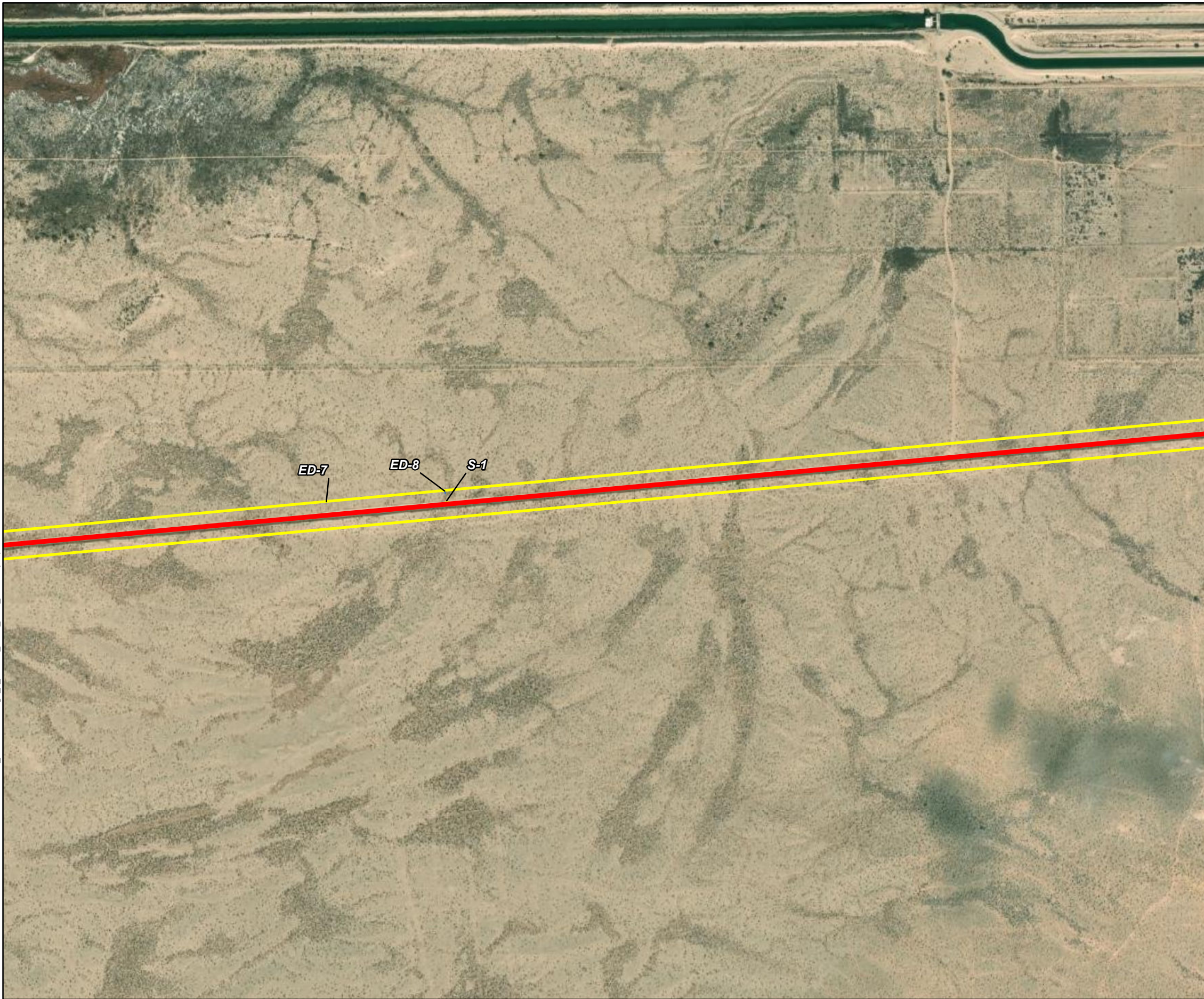
Service Layer Credits: Sources: Esri, HERE, Garmin, USGS, Intermap, INCREMENT P, NRCan, Esri Japan, METI, Esri China (Hong Kong), Esri Korea, Esri (Thailand), NGCC, (c) OpenStreetMap contributors, and the GIS User Community



Map Date: 7/6/2022

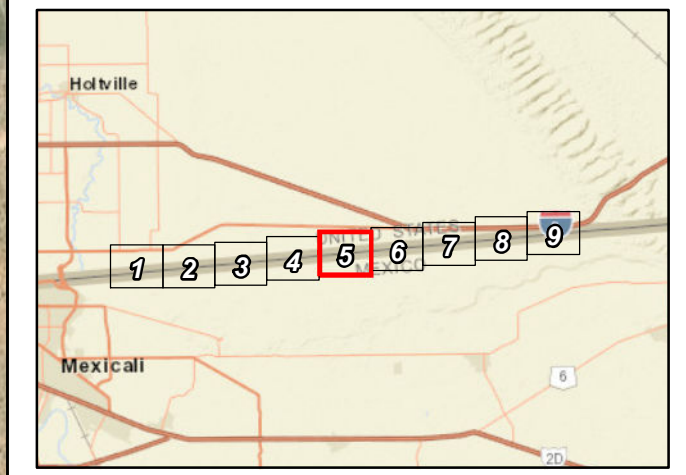


ECORP: N:\2020\2020-142 Cedar 1 Solar\MAPS\Jurisdictional_Delineation\Vega_4_Access_Road_ARC_V2.mxd (TR)\rotellini 7/6/2022



- Map Features**
- Access Road - 69.735 ac.
 - 150' Buffer
- Aquatic Resources**
- Swale - Bank to Bank
 - Swale - OHWM
 - Ephemeral Drainage - Bank-to-Bank
 - Ephemeral Drainage - OHWM

Service Layer Credits: Sources: Esri, HERE, Garmin, USGS, Intermap, INCREMENT P, NRCan, Esri Japan, METI, Esri China (Hong Kong), Esri Korea, Esri (Thailand), NGCC, (c) OpenStreetMap contributors, and the GIS User Community

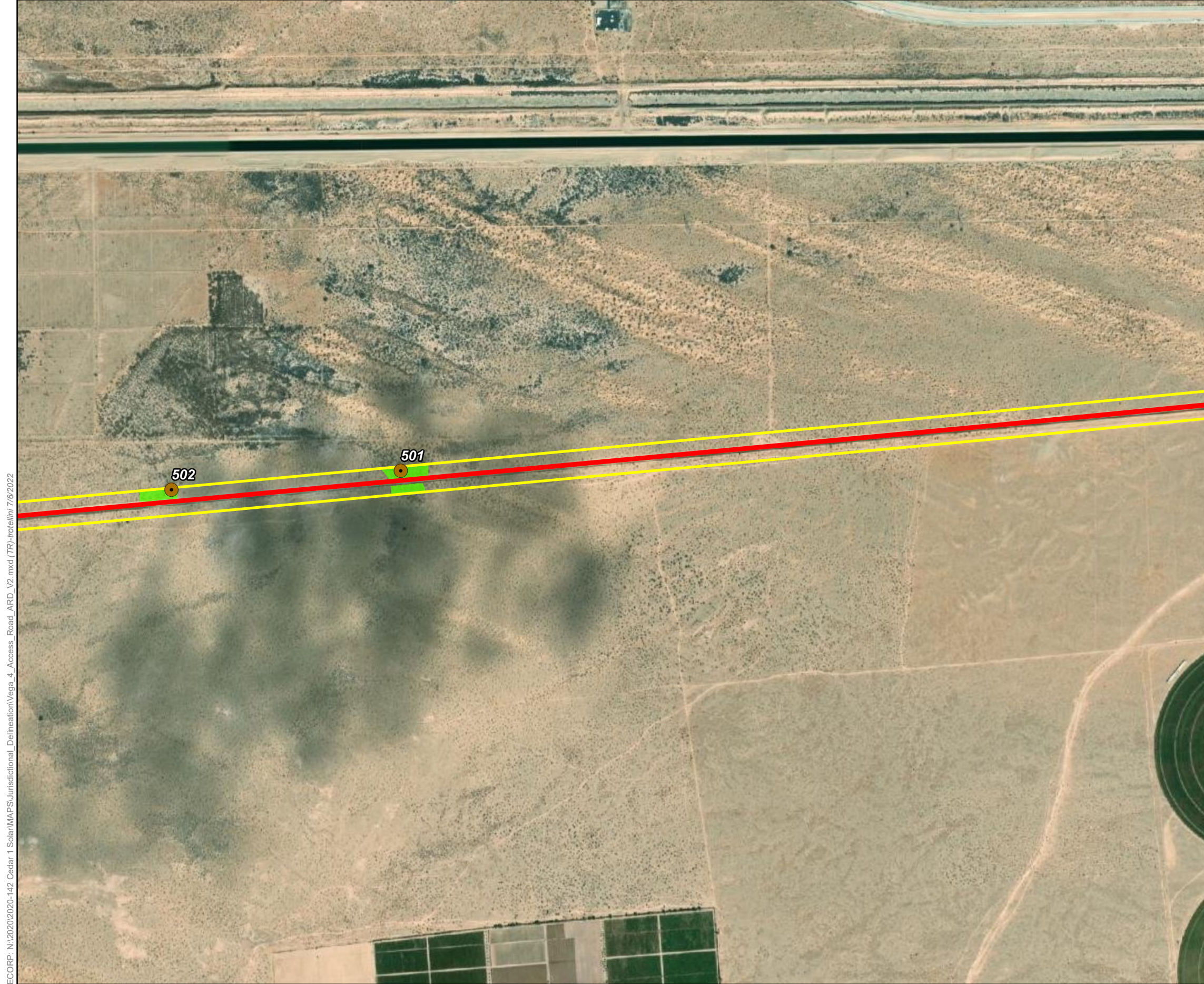


Map Date: 7/6/2022



PC ORIGINAL PKG

Figure 5. Aquatic Resources Delineation Sheet 5 of 9 2020-142 Vega SES 4



- Map Features**
- Access Road - 69.735 ac.
 - 150' Buffer
 - Upland Point
- CDFW-Regulated Habitat**
- Riparian Habitat

ECORP: N:\2020\2020-142 Cedar 1 Solar\MAPS\Jurisdictional_Delineation\Vega_4_Access_Road_ARD_V2.mxd (TR)-frotellini 7/6/2022

Service Layer Credits: Sources: Esri, HERE, Garmin, USGS, Intermap, INCREMENT P, NRCan, Esri Japan, METI, Esri China (Hong Kong), Esri Korea, Esri (Thailand), NGCC, (c) OpenStreetMap contributors, and the GIS User Community

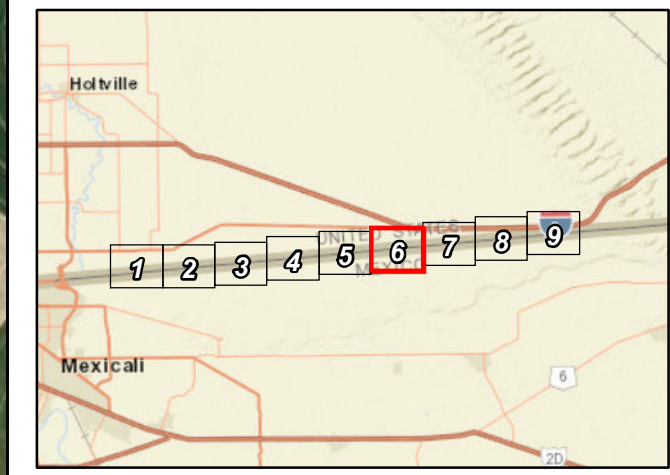


Figure 5. Aquatic Resources Delineation
Sheet 6 of 9
 2020-142 Vega SES 4



- Map Features**
- Access Road - 69.735 ac.
 - 150' Buffer

ECORP: N:\2020\2020-142 Cedar 1 Solar\MAPS\Jurisdictional_Delineation\Vega_4_Access_Road_AR_D_V2.mxd (TR)-rotellini 7/6/2022

Service Layer Credits: Sources: Esri, HERE, Garmin, USGS, Intermap, INCREMENT P, NRCan, Esri Japan, METI, Esri China (Hong Kong), Esri Korea, Esri (Thailand), NGCC, (c) OpenStreetMap contributors, and the GIS User Community

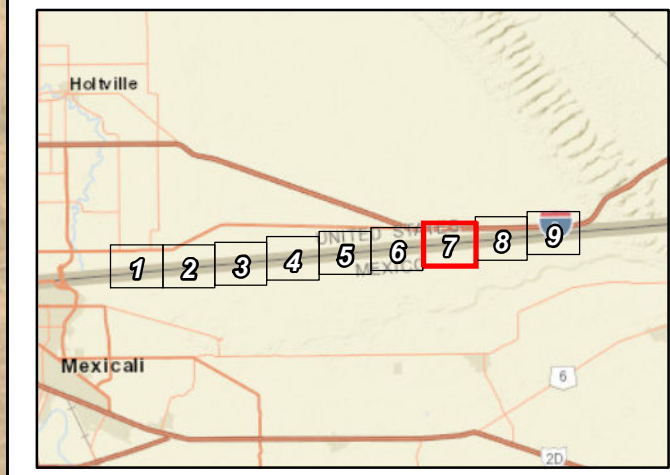




Figure 5. Aquatic Resources Delineation
Sheet 7 of 9
 2020-142 Vega SES 4

ECORP: N:\2020\2020-142 Cedar 1 Solar\MAPS\Jurisdictional_Delineation\Vega_4_Access_Road_AR_D_V2.mxd (TR)-rotellini 7/6/2022



Map Features

-  Access Road - 69.735 ac.
-  150' Buffer

Service Layer Credits: Sources: Esri, HERE, Garmin, USGS, Intermap, INCREMENT P, NRCan, Esri Japan, METI, Esri China (Hong Kong), Esri Korea, Esri (Thailand), NGCC, (c) OpenStreetMap contributors, and the GIS User Community

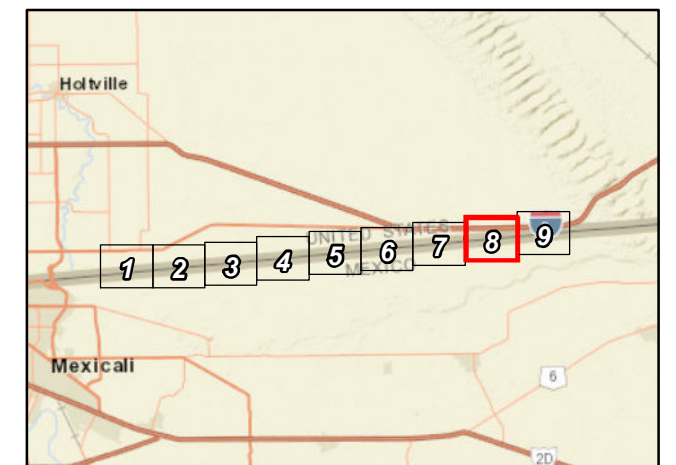
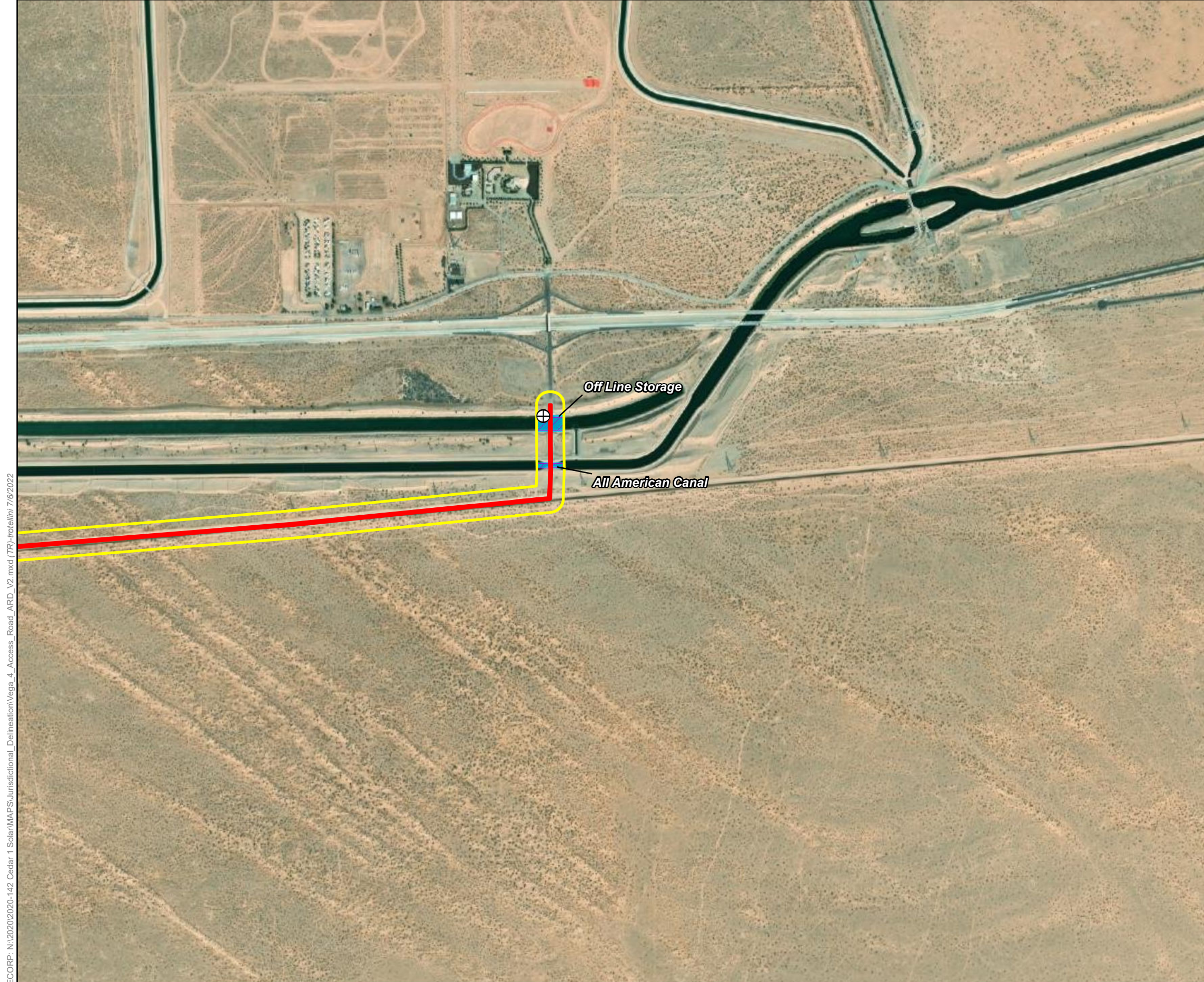


Figure 5. Aquatic Resources Delineation
Sheet 8 of 9

2020-142 Vega SES 4



- Map Features**
- Access Road - 69.735 ac.
 - 150' Buffer
 - ⊕ OWHM Cross Section
- Aquatic Resources**
- Canal - Bank-to-Bank (No Impacts)
 - Canal - OWHM (No Impacts)

ECORP: N:\2020\2020-142 Cedar 1 Solar\MAPS\Jurisdictional Delineation\Vega_4_Access_Road_ARC_V2.mxd (TR)-rotellini 7/6/2022

Service Layer Credits: Sources: Esri, HERE, Garmin, USGS, Intermap, INCREMENT P, NRCan, Esri Japan, METI, Esri China (Hong Kong), Esri Korea, Esri (Thailand), NGCC, (c) OpenStreetMap contributors, and the GIS User Community

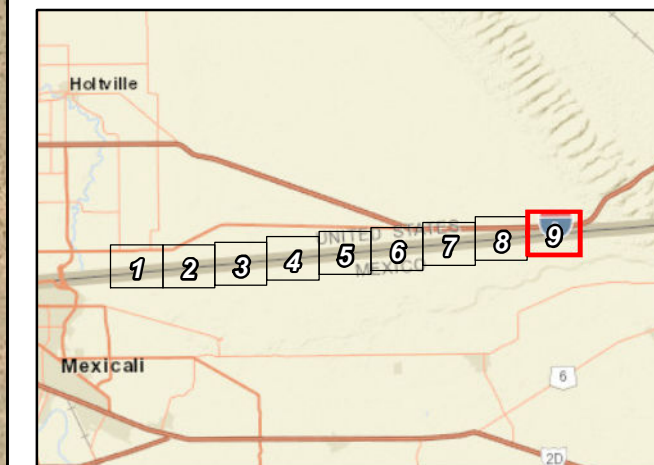


Figure 5. Aquatic Resources Delineation
Sheet 9 of 9
 2020-142 Vega SES 4

Table 5. Aquatic Resources within the Project								
Resource Name ¹	Aquatic Resources Classification		OHWM/Wetland Presence Summary	Dominant Vegetation	WOTUS/WSC Size (acres) ³	CDFW Size (acres) ⁴	Resource Size (linear feet)	Riparian Habitat Size (acres)
	Cowardin ²	Location (latitude, longitude)						
ED-1	R6	32.67954541, -115.31681051	OHWM indicators: defined bed and bank and vegetation matted down, bent, or absent.	Tamarisk Thickets	0.282	0.275	701.547	N/A
ED-2	R6	32.67977819, -115.31686094	OHWM indicators: defined bed and bank and vegetation matted down, bent, or absent.	Tamarisk Thickets	0.288	0.357	717.545	N/A
ED-3	R6	32.67983223, -115.31627266	OHWM indicators: defined bed and bank.	Tamarisk Thickets	0.231	0.415	806.879	N/A
FSW-1	PSS1C	32.67960789, -115.31829880	Wetland criteria met: hydrophytic vegetation present, hydric soils present, and hydrological indicators present.	Tamarisk Thickets	18.401	N/A	N/A	N/A
FSW-2	PSS1C	32.68345488, -115.31168036	Wetland criteria met: hydrophytic vegetation present, hydric soils present, and hydrological indicators present.	Tamarisk Thickets	0.372	N/A	N/A	N/A
FSW-3	PSS1C	32.68496608, -115.30521625	Wetland criteria met: hydrophytic vegetation present, hydric soils present, and hydrological indicators present.	Tamarisk Thickets	40.344	N/A	N/A	N/A
PD-1	R2AB3H	32.67989722, -115.31746236	Wetland criteria met within the channel with OHWM indicators; bisects wetland riparian habitat.	Tamarisk Thickets	0.343	0.687	664.876	2.527
Unassociated Riparian Habitat	N/A	32.68384969, -115.30666666	N/A	Arrow Weed and Tamarisk thickets	5.793	N/A	N/A	N/A
Unassociated Disturbed Riparian Habitat	N/A	32.69004265, -115.29438590	N/A	Disturbed Arrow Weed Thickets	N/A	N/A	N/A	5.696
All American Canal ⁵	R2UBHx	32.70397136, -114.95717380	N/A	Unvegetated	0.029	0.037	24.996	N/A
Off Line Storage ⁵	R2UBHx	32.70532216, -114.95718630	N/A	Unvegetated	0.086	0.115	24.971	N/A
Total:					66.169	1.886	2940.815	

1: ED= Ephemeral Drainage, FSW= Freshwater Forested/Shrub Wetland, PD= Perennial Drainage.

2: Cowardin Codes: (R6) Riverine, ephemeral; (PEM1C) Freshwater Emergent Wetland; (PSS1C) Freshwater Forested/Shrub Wetland; (R2AB3H) Riverine, lower perennial, aquatic bed, rooted vascular; (R2UBHx) Riverine, Lower Perennial, Unconsolidated Bottom, Permanently Flooded, Excavated (USFWS 2022b).

3: OHWM widths were used to estimate WOTUS (Waters of the U.S.) and WSC (Waters of the State of California) areas.

4: Top- of-Bank widths were used to estimate CDFW acreages.

5: Impacts to these features are not expected to occur, as features flow beneath access road entry bridge.

4.2.1 Wetlands

4.2.1.1 Freshwater Forested/Shrub Wetland

Freshwater forested/shrub wetlands (FSW) are dominated by woody vegetation such as true shrubs, young trees (saplings), and trees or shrubs that are stunted due to environmental conditions. They are seasonally flooded: therefore, surface water is present for extended periods, particularly in the early growing season, but is absent by the end of the growing season in most years. The water table can be variable after a flooding event, and ranges from saturation at the ground surface to a water table well below the ground surface (USFWS 2022a). There are three FSW within the Study Area (FSW-1, FSW-2, and FSW-3; Figure 5).

Sampling Points 1, 2, 401, 402, and 404 were collected in the freshwater forested/shrub wetland in the western portion of the solar field Study Area (FSW-1). Sampling Point 403 was collected outside the limits of FSW-1. At Sampling Point 402, plant species observed included tamarisk, willow baccharis, and arrow weed. Soils were determined to be hydric based on the presence of hydric soil indicators depleted below dark surface (A11) and redox depressions (F8). Wetland hydrology indicators observed at Sampling Point 402 included saturation (A3), drift deposits (B3), and oxidized rhizospheres along living roots (C3).

Sampling Point 14 was collected in the freshwater forested/shrub wetland in the northwestern portion of the solar field Study Area (FSW-2). Plant species observed within the wetland included tamarisk, arrow weed, and screwbean mesquite. Soils were determined to be hydric based on the presence of hydric soil indicator redox depressions (F8). Wetland hydrology indicators observed at Sampling Point 14 included sediment deposits (B2), drift deposits (B3), and water-stained leaves (B9).

Sampling Points 7, 11, and 12 were collected in the FSW in the northeastern portion of the solar field Study Area (FSW-3). Sampling Points 6, 9, 10, and 13 were collected outside the limits of FSW-3. At Sampling Point 7, plant species observed within the wetland included willow baccharis, arrow weed, and cattail. Soils were determined to be hydric based on the presence hydric soil indicator redox depressions (F8). Wetland hydrology indicators observed at Sampling Point 7 included saturation (A3) and water-stained leaves (B9).

4.2.2 Other Aquatic Resources

4.2.2.1 Perennial Drainage

Perennial drainages (PD) are linear features that exhibit a bed and bank and an OHWM. These features typically contain surface water flowing continuously year-round. OHWM indicators observed for the perennial drainage (PD-1) that occurs within the western portion of the Study Area included defined bed and bank, change in vegetation species, change in vegetation cover, and natural line impressed in bank. The existing hydrology of PD-1 supports emergent wetland habitat within the channel.

Sampling Point 2 was collected within the emergent wetland in the bed of PD-1. At Sampling Point 2, plant species observed within the drainage included tamarisk and cattail. Soils were determined to be hydric based on the presence of hydric soil indicators hydrogen sulfide (A4), loamy gleyed matrix (F2), and

redox depressions (F8). Wetland hydrology indicators observed at Sampling Point 2 included surface water (A1), high water table (A2), saturation (A3), and hydrogen sulfide odor (C1).

4.2.2.2 Ephemeral Drainage

Ephemeral drainages (ED) are linear features that exhibit a bed and bank and an OHWM. These features typically convey runoff for short periods of time, during and immediately following rain events, and are not influenced by groundwater sources at any time during the year. The solar field Study Area contains three ephemeral drainages within the western portion of the Project (ED-1, ED-2, and ED-3). These manmade drainages convey flow through the Study Area and into FEW-1. Additional ephemeral drainages exist within the buffer of the access road, but do not overlap with the Study Area.

No sampling points were collected within ephemeral features because soils and vegetation did not imply that wetlands could be present. Wetland hydrology indicators were present at these features, however, leading to the conclusion that they conveyed water irregularly.

4.2.3 Manmade Features

4.2.3.1 Main Canals

A total of two main canals managed by IID, the All-American Canal and the associated Off-line Storage Canal, were identified within the access road portion of the Study Area and are assumed to flow perennially. Both canals bisect the easternmost portion of the Study Area. The concrete-lined All-American Canal is maintained by IID in order to be free of vegetation for water conveyance efficiency. The Off-line Storage Canal is natural-bottomed, and flow and water levels are maintained by IID. The All-American Canal brings water from the Colorado River at the Imperial Dam and supplies it to the Imperial Valley through smaller lateral canals, all of which ultimately drain to the Salton Sea (IID 2022). Because these canals flow underneath the access road entry bridge, no impacts are expected to occur to either canal.

4.2.4 Associated Habitat

4.2.4.1 Riparian Habitat

Both riparian habitat and disturbed riparian habitat are present within the Study Area. They are associated with the floodplain adjacent to the wetlands and drainages throughout the Project. Topographically, these areas sit within a low point. Riparian habitat within the Study Area contains hydrophytic vegetation and hydrological indicators but lack hydric soil indicators, whereas disturbed riparian habitat is riparian habitat that has been previously altered. A total of 5.793 acres of riparian habitat and 8.223 acres of disturbed riparian habitat exists within the Study Area.

Sampling Point 10 was collected in riparian habitat located along FSW-3 within the northern portion of the solar field Study Area. Plant species observed included tamarisk, arrow weed, and alkali goldenbush. Hydric soil indicators were determined to be absent at this sampling point. Wetland hydrology indicators observed at Sampling Point 10 included sediment deposits (B2) and water-stained leaves (B9).

Sampling Point 400 was collected in riparian habitat located within the northeastern portion of the solar field Study Area. Plant species observed included tamarisk, arrow weed, and cattail. Hydric soil indicators were determined to be absent at this sampling point. Wetland hydrology indicators observed at Sampling Point 400 included high water table (A2), saturation (A3), and water marks (B1).

Sampling point 501 was collected in riparian habitat located within the northern buffer area of the access road Study Area. Plant species observed included tamarisk, arrow weed, creosote bush, and alkali goldenbush. Hydric soil indicators and wetland hydrology indicators were determined to be absent at this sampling point.

Sampling point 502 was collected in riparian habitat located within the northern buffer area of the access road Study Area. Plant species observed included tamarisk, arrow weed, and white bursage. Hydric soil indicators were determined to be absent at this sampling point. Wetland hydrology indicators present included surface soil cracks (B6).

5.0 JURISDICTIONAL ASSESSMENT

According to Regulatory Guidance Letter 16-01, an applicant may request a Preliminary Jurisdictional Delineation (PJD) "in order to move ahead expeditiously to obtain a Corps permit authorization where the requestor determines that it is in his or her best interest to do so... even where initial indications are that the aquatic resources on a parcel may not be jurisdictional" (USACE 2016). A significant nexus evaluation is not necessary to obtain a PJD. The following information on connectivity of wetlands and other waters in the Study Area to TNWs is provided should an Approved Jurisdictional Determination be necessary.

The perennial and ephemeral drainages within the Study Area appear to directly or indirectly (via sheet and/or subsurface flow) connect to adjacent wetlands to the west. The wetlands appear to be fed by the All-American Canal and groundwater seepage. The All-American Canal brings water from the Colorado River at the Imperial Dam and supplies it to the Imperial Valley through smaller lateral canals, all of which ultimately drain to the Salton Sea. The Salton Sea is considered TNW (USACE 2001). The wetlands, perennial drainage, and ephemeral drainages within the Study Area would likely be subject to regulation under Section 404 of the CWA. Ultimately, the jurisdictional determination will be made by the USACE. Regardless of federal jurisdiction status, all aquatic resources delineated on site, including riparian habitat, are subject to CDFW and/or RWQCB jurisdiction.

6.0 CONCLUSION

ECORP's mapping of aquatic resources in the Study Area are depicted on Figure 5. Acreages shown in Table 5 represent calculated estimates of the extent of aquatic resources within the Study Area and are subject to modification following USACE review and/or the verification process. Impacts to aquatic features may require permits from several regulatory agencies pursuant to federal and state laws. Wetlands, perennial drainages, and ephemeral drainages present within the Study Area would require a permit pursuant to Section 404 of the CWA (USACE), certification compliance with Section 401 of the CWA (RWQCB) and the Porter-Cologne Act (RWQCB), and a Lake or Streambed Alteration Agreement pursuant to California Fish and Game Code Section 1600 (CDFW). Impacts to any associated riparian habitat within

the aforementioned features are also subject to an agreement pursuant to California Fish and Game Code Sections 1600 and 1602 (CDFW).

7.0 REFERENCES

- Baldwin, B. G., D.H Goldman, D.J. Keil, R. Patterson, T.J. Rosatti, and D.H. Wilken, editors. 2012. The Jepson Manual; Vascular Plants of California, Second Edition. University of California Press, Berkeley, California. 1,519 pp. + app.
- CDFW. 2020. Environmental Review and Permitting. Available online: <https://wildlife.ca.gov/Conservation/Environmental-Review>. Accessed September 16, 2020.
- Environmental Laboratory. 1987. Corps of Engineers Wetlands Delineation Manual. Technical Report Y-87-1. U. S. Army Engineer Waterways Experiment Station. Vicksburg, Mississippi.
- ESRI. "Topographic" [basemap]. Scale Not Given. "World Imagery". Accessed November 30, 2020 and April 20, 2022. <https://ecorpmapping.maps.arcgis.com/home/item.html?id=0563aff34bdf4e0caa51bba3c69817d9>.
- Google Earth. 2018. <https://www.google.com/maps/@34.6457,-116.99432,30433m/data=!3m1!1e3>. Dated April 4, 2018.
- IID. 2022. Water Transportation System. Available online: <https://www.iid.com/water/water-transportation-system>. Accessed April 22, 2022.
- Kollmorgen Instruments Company. 1990. Munsell Soil Color Charts. Kollmorgen Corporation. Baltimore, Maryland.
- Natural Resources Conservation Service (NRCS), U.S. Geological Survey (USGS), U.S. Environmental Protection Agency (USEPA). 2022. Watershed Boundary Dataset for California. Available online: <https://datagateway.nrcs.usda.gov>. Accessed April 23, 2022.
- Natural Resources Conservation Service (NRCS). 2022a. Soil Survey Geographic Database. Available online: <https://websoilsurvey.sc.egov.usda.gov/App/WebSoilSurvey.aspx>. Accessed April 22, 2022.
- _____. 2022b. Soil Data Access Hydric Soils List. Available at <https://www.nrcs.usda.gov/wps/portal/nrcs/main/soils/use/hydric/>. Accessed April 25, 2022.
- _____. 2022c. Official Soil Series Descriptions. Available at <https://www.nrcs.usda.gov/wps/portal/nrcs/main/soils/use/hydric/>. Accessed April 25, 2022.
- NETROnline. 2022. "Historic Aerials." NETR Online, www.historicaerials.com/. Accessed November 30, 2020 and April 28, 2022.
- NOAA. 2022a. NCDC 1981-2010 Climate Normals for El Centro, California. Available Online: <https://www.ncdc.noaa.gov/cdo-web/datatools/normals>. Accessed September 16, 2020 and April 27, 2022.
- _____. 2022b. Climate Date Online: Daily Precipitation Summaries for El Centro 2 SSW, California. Available Online: <https://www.ncdc.noaa.gov/cdo-web/search>. Accessed September 16, 2020 and April 27, 2022.

- USACE. 2022. The Antecedent Precipitation Tool. Available Online: <https://github.com/jDeters-USACE/Antecedent-Precipitation-Tool/releases/tag/v1.0.13>. Accessed April 27, 2022.
- _____. 2018. National Wetland Plant List, version 3.4. USACE Engineer Research and Development Center. Cold Regions Research and Engineering Laboratory, Hanover, NH. Available online: <http://wetland-plants.usace.army.mil/>
- _____. 2017. Minimum Standards for Acceptance of Aquatic Resources Delineation Reports. Dated March 2017. Los Angeles District.
- _____. 2016. Regulatory Guidance Letter 16-01, Jurisdictional Determinations. Dated October 2016.
- _____. 2010. Updated Datasheet for the Identification of the Ordinary High Water Mark (OHWM) in the Arid West Region of the Western United States. K.E. Curtis and R.W. Lichvar. ERDC/CRREL TN-10-1. Hanover, NH: U.S. Army Engineer Research and Development Center.
- _____. 2008a. Regional Supplement to the Corps of Engineers Wetland Delineation Manual: Arid West Region. Ed. J.S. Wakeley, R.W. Lichvar, and C.V. Noble. ERDC/EL TR-06-16. Vicksburg, MS: U.S. Army Engineer Research and Development Center.
- _____. 2008b. A Field Guide to the Identification of the Ordinary High Water Mark (OHWM) in the Arid West Region of the Western United States. R. W. Lichvar and S. M. McColley. ERDC/CRREL TR-08-12. Hanover, NH: U.S. Army Engineer Research and Development Center.
- _____. 2001. Jurisdictional Determination for the Salton Sea and its Tributaries in light of the U.S. Supreme Court Decision in the Solid Waste Agency of Northern Cook County (SWANCC). Dated January 24, 2001. Accessible online: <https://www.spl.usace.army.mil/Missions/Regulatory/Jurisdictional-Determination/Navigable-Waterways/>.
- USEPA. 2021. Navigable Waters Protection Rule: The Antecedent Precipitation Tool (APT). Dated January 21, 2021. Accessed April 27, 2022.
- USGS. 2022. National Hydrography Dataset. Accessible online: <https://www.usgs.gov/national-hydrography/nhdplus-high-resolution>. Accessed April 22, 2022.
- _____. 1976. "Bonds Corner, California" 7.5-minute Quadrangle. Geological Survey. Denver, Colorado.
- _____. 1979. "Midway Well NW, California" 7.5-minute Quadrangle. Geological Survey. Denver, Colorado.
- _____. 1979. "Midway Well, California" 7.5-minute Quadrangle. Geological Survey. Denver, Colorado.
- _____. 1976. "Grays Well, California" 7.5-minute Quadrangle. Geological Survey. Denver, Colorado.
- USFWS. 2022a. National Wetlands Inventory. Accessible online: <https://www.fws.gov/wetlands/>. Accessed September 24, 2020 and April 22, 2022.
- _____. 2022b. National Wetlands Inventory: Wetland Classification Codes. Accessible online: <https://www.fws.gov/wetlands/Data/Wetland-Codes.html>

LIST OF ATTACHMENTS

Attachment A – Driving Directions to Study Area

Attachment B – OHWM and Wetland Determination Data Forms - Arid West

Attachment C – Representative Site Photographs

Attachment D – USACE ORM Aquatic Resources Table

Attachment E – Digital Data

Driving Directions to Study Area



US Army Corps of Engineers
915 Wilshire Blvd, Los Angeles, CA 90017

Get on CA-110 N/Harbor Fwy from S Figueroa St

- 2 min (0.5 mi)

 1. Head southeast on Wilshire Blvd toward S Figueroa St
- 417 ft

 2. Turn left at the 1st cross street onto S Figueroa St
- 0.2 mi

 3. Turn left at the 3rd cross street onto W 5th St
- 174 ft

 4. Keep right at the fork, follow signs for Harbor Fwy/CA-110 N and merge onto CA-110 N/Harbor Fwy
- 0.2 mi

Follow I-10 E to CA-86 S in Indio

- 2 hr 2 min (129 mi)

 5. Merge onto CA-110 N/Harbor Fwy
- 0.5 mi

 6. Take exit 24A toward I-5 S/I-10 E
- 0.5 mi

 7. Use the left lane to merge onto US-101 S
- 453 ft

 8. Keep left to stay on US-101 S
- 1.2 mi

 9. Keep left at the fork to continue on San Bernardino Fwy, follow signs for I-10 E/San Bernardino
- 1.2 mi

 10. Continue onto I-10 E/San Bernardino Fwy
- 12.2 mi

 11. Keep left to stay on I-10 E
- 52.4 mi

 12. Keep left to stay on I-10 E
- 1.5 mi

 13. Keep left to stay on I-10 E
- 59.7 mi

 14. Keep right to continue on CA-86 S, follow signs for Brawley/El Centro/865 Expy
- 1 hr 4 min (66.7 mi)

Follow CA-78, CA-111 S and I-8 E to Bonds Corner Rd. Take exit 128 from I-8 E

- 30 min (30.4 mi)

 15. Use the left 2 lanes to turn left onto CA-78
- 3.4 mi

 16. Use any lane to turn sharply right to stay on CA-78
- 2.9 mi

 17. Continue onto CA-111 S
- 14.3 mi

 18. Take the exit onto I-8 E toward Yuma
- 9.5 mi

 19. Take exit 128 for Bonds Corner Rd
- 0.2 mi

Follow Bonds Corner Rd and CA-98 E to your destination

- 10 min (8.6 mi)

 20. Turn right onto Bonds Corner Rd
- 5.4 mi

 21. Turn left onto CA-98 E
- 3.1 mi

 22. Turn right
- 299 ft

Holtville
California 92250

These directions are for planning purposes only. You may find that construction projects, traffic, weather, or other events may cause conditions to differ from the map results, and you should plan your route accordingly. You must obey all signs or notices regarding your route.

OHWM and Wetland Determination Data Forms – Arid West Region

Arid West Ephemeral and Intermittent Streams OHWM Datasheet

Project: Vega SES 4 Project Number: 2020-142 Stream: PD-1 Investigator(s): C. Torres	Date: 11/05/2020 Town: Holtville Photo begin file#:	Time: 0900-1030 State: CA Photo end file#:
---------------------------------------------------------------------------------------------------------------------------	--------------------------------------------------------------------------------	-----------------------------------------------------------------------

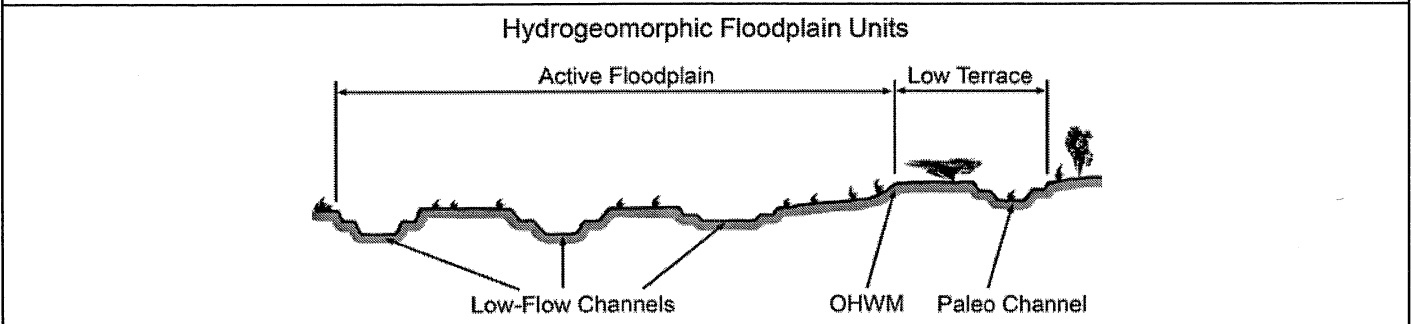
Y <input checked="" type="checkbox"/> / N <input type="checkbox"/> Do normal circumstances exist on the site? Y <input type="checkbox"/> / N <input checked="" type="checkbox"/> Is the site significantly disturbed?	Location Details: South of Salton Sea, directly south of All-American Canal and north of US -Mexico border. Projection: Datum: NAD83 Coordinates:
------------------------------------------------------------------------------------------------------------------------------------------------------------------------------------------------------------------------------	----------------------------------------------------------------------------------------------------------------------------------------------------------------------------------------------------------------------------

Potential anthropogenic influences on the channel system:
 Site priorly used for agriculture and has been previously disturbed/altered. Runoff from adjacent agricultural land collects and is concentrated in the Study Area. Manmade berms line the drainages. Drainage system within a palustrine wetland in western portion of site.

Brief site description:
 The Study Area is downslope of the All-American Canal, which brings water from the Colorado River and likely feeds into the site. Runoff generally flows south from the direction of the All-American Canal and toward the U.S.-Mexico border

Checklist of resources (if available):

<input checked="" type="checkbox"/> Aerial photography Dates: 1953, 1996-2016 (historic aeriels); 11/2020 (sUAS imagery) <input checked="" type="checkbox"/> Topographic maps <input type="checkbox"/> Geologic maps <input checked="" type="checkbox"/> Vegetation maps <input checked="" type="checkbox"/> Soils maps <input type="checkbox"/> Rainfall/precipitation maps <input type="checkbox"/> Existing delineation(s) for site <input checked="" type="checkbox"/> Global positioning system (GPS) <input type="checkbox"/> Other studies	<input type="checkbox"/> Stream gage data Gage number: Period of record: <input type="checkbox"/> History of recent effective discharges <input type="checkbox"/> Results of flood frequency analysis <input type="checkbox"/> Most recent shift-adjusted rating <input type="checkbox"/> Gage heights for 2-, 5-, 10-, and 25-year events and the most recent event exceeding a 5-year event
------------------------------------------------------------------------------------------------------------------------------------------------------------------------------------------------------------------------------------------------------------------------------------------------------------------------------------------------------------------------------------------------------------------------------------------------------------------------------------------------------------------------------------------------------------------------------	-----------------------------------------------------------------------------------------------------------------------------------------------------------------------------------------------------------------------------------------------------------------------------------------------------------------------------------------------------------------------------------------------------------------



Procedure for identifying and characterizing the floodplain units to assist in identifying the OHW:

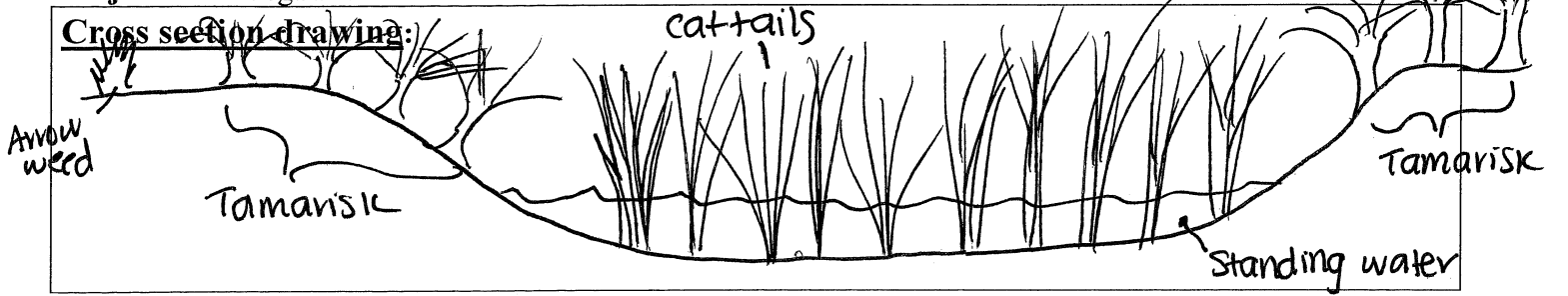
1. Walk the channel and floodplain within the study area to get an impression of the geomorphology and vegetation present at the site.
2. Select a representative cross section across the channel. Draw the cross section and label the floodplain units.
3. Determine a point on the cross section that is characteristic of one of the hydrogeomorphic floodplain units.
 - a) Record the floodplain unit and GPS position.
 - b) Describe the sediment texture (using the Wentworth class size) and the vegetation characteristics of the floodplain unit.
 - c) Identify any indicators present at the location.
4. Repeat for other points in different hydrogeomorphic floodplains across the cross section.
5. Identify the OHW and record the indicators. Record the OHW position via:

<input type="checkbox"/> Mapping on aerial photograph	<input checked="" type="checkbox"/> GPS
<input type="checkbox"/> Digitized on computer	<input type="checkbox"/> Other:

Project ID: Vega SES 4 Cross section ID: PD-1

Date: 11/05/2020

Time: 0900-1030



OHWM

GPS point: 32.680595, -115.318096

Indicators:

- Change in average sediment texture
- Change in vegetation species
- Change in vegetation cover
- Break in bank slope
- Other: Natural line
- Other: _____

Comments:

Emergent wetland present within bed of drainage, and standing water present. Vegetation included cattail and tamarisk.

Floodplain unit: Low-Flow Channel Active Floodplain Low Terrace

GPS point: 32.680595, -115.318096

Characteristics of the floodplain unit:

Average sediment texture: Coarse silt

Total veg cover: 70 % Tree: 5 % Shrub: 65 % Herb: 0 %

Community successional stage:

- NA
- Early (herbaceous & seedlings)
- Mid (herbaceous, shrubs, saplings)
- Late (herbaceous, shrubs, mature trees)

Indicators:

- Mudcracks
- Ripples
- Drift and/or debris
- Presence of bed and bank
- Benches
- Soil development
- Surface relief
- Other: _____
- Other: _____
- Other: _____

Comments:

Standing water present; one drainage directly adjacent to the east.

Arid West Ephemeral and Intermittent Streams OHW M Datasheet

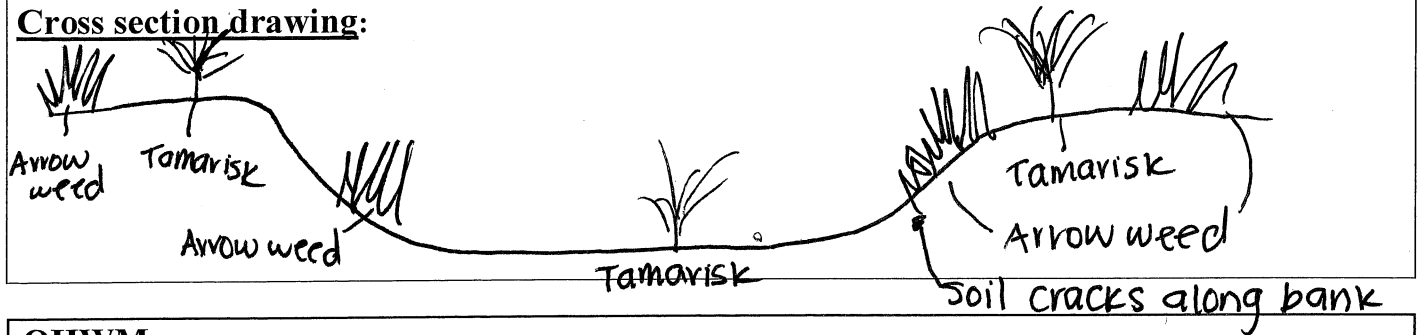
Project: Vega SES 4 Project Number: 2020-142 Stream: ED-1 Investigator(s): C. Torres, J. Kendrick	Date: 11/05/2020 Town: Holtville Photo begin file#: Time: 0900-1030 State: CA Photo end file#:
Y <input checked="" type="checkbox"/> / N <input type="checkbox"/> Do normal circumstances exist on the site? Y <input type="checkbox"/> / N <input checked="" type="checkbox"/> Is the site significantly disturbed?	Location Details: South of Salton Sea, directly south of All-American Canal and north of US -Mexico border Projection: Datum: NAD83 Coordinates:
Potential anthropogenic influences on the channel system: Site priorly used for agriculture and has been previously disturbed/alterd. Runoff from adjacent agricultural land collects and is concentrated in the Study Area. Manmade berms line the drainages. Drainage system within a palustrine wetland in western portion of site.	
Brief site description: The Study Area is downslope of the All-American Canal, which brings water from the Colorado River and likely feeds into the site. Runoff generally flows south from the direction of the All-American Canal and toward the U.S.-Mexico border	
Checklist of resources (if available): <input checked="" type="checkbox"/> Aerial photography Dates: 1953, 1996-2016 (historic aerials); 11/2020 (sUAS imagery) <input checked="" type="checkbox"/> Topographic maps <input type="checkbox"/> Geologic maps <input checked="" type="checkbox"/> Vegetation maps <input checked="" type="checkbox"/> Soils maps <input type="checkbox"/> Rainfall/precipitation maps <input type="checkbox"/> Existing delineation(s) for site <input checked="" type="checkbox"/> Global positioning system (GPS) <input type="checkbox"/> Other studies <input type="checkbox"/> Stream gage data Gage number: Period of record: <input type="checkbox"/> History of recent effective discharges <input type="checkbox"/> Results of flood frequency analysis <input type="checkbox"/> Most recent shift-adjusted rating <input type="checkbox"/> Gage heights for 2-, 5-, 10-, and 25-year events and the most recent event exceeding a 5-year event	
Hydrogeomorphic Floodplain Units 	
Procedure for identifying and characterizing the floodplain units to assist in identifying the OHW M: 1. Walk the channel and floodplain within the study area to get an impression of the geomorphology and vegetation present at the site. 2. Select a representative cross section across the channel. Draw the cross section and label the floodplain units. 3. Determine a point on the cross section that is characteristic of one of the hydrogeomorphic floodplain units. a) Record the floodplain unit and GPS position. b) Describe the sediment texture (using the Wentworth class size) and the vegetation characteristics of the floodplain unit. c) Identify any indicators present at the location. 4. Repeat for other points in different hydrogeomorphic floodplain units across the cross section. 5. Identify the OHW M and record the indicators. Record the OHW M position via: <input type="checkbox"/> Mapping on aerial photograph <input checked="" type="checkbox"/> GPS <input type="checkbox"/> Digitized on computer <input type="checkbox"/> Other:	

Project ID: Vega SES 4 Cross section ID: ED-1

Date: 11/05/2020

Time: 0900-1030

Cross section drawing:



OHW

GPS point: 32.680267, -115.317448

Indicators:

- Change in average sediment texture
- Change in vegetation species
- Change in vegetation cover
- Break in bank slope
- Other: _____
- Other: _____

Comments:

Vegetated channel adjacent to a perennial drainage (with emergent wetland in the bed of the channel) to the west and one ephemeral drainage to the east. Vegetation within channel consists of arrow weed and tamarisk. Man-made berms line the channel.

Floodplain unit: Low-Flow Channel Active Floodplain Low Terrace

GPS point: 32.680267, -115.317448

Characteristics of the floodplain unit:

Average sediment texture: Medium sand/sand

Total veg cover: 55 % Tree: 20 % Shrub: 35 % Herb: 0 %

Community successional stage:

- NA
- Early (herbaceous & seedlings)
- Mid (herbaceous, shrubs, saplings)
- Late (herbaceous, shrubs, mature trees)

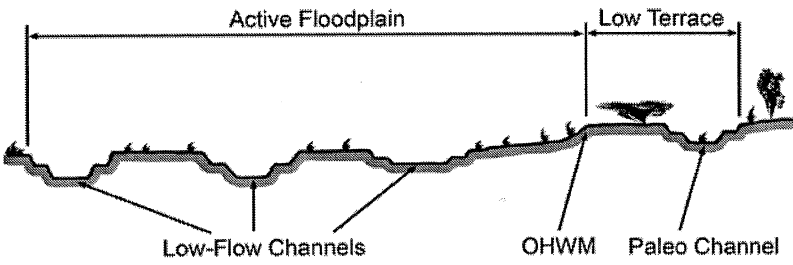
Indicators:

- Mudcracks
- Ripples
- Drift and/or debris
- Presence of bed and bank
- Benches
- Soil development
- Surface relief
- Other: _____
- Other: _____
- Other: _____

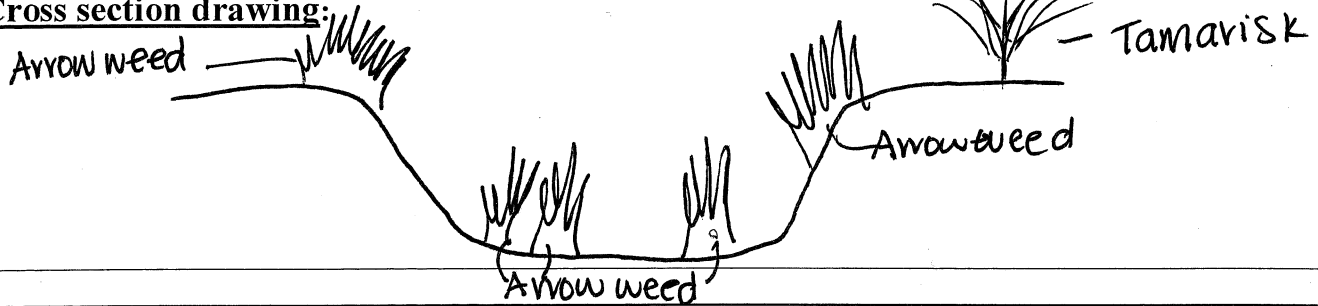
Comments:

Salt crust present, but likely from adjacent agricultural run-off. Water seems to flood over bank of channel to adjacent channels/wetland.

Arid West Ephemeral and Intermittent Streams OHWM Datasheet

Project: Vega SES 4 Project Number: 2020-142 Stream: ED-2 Investigator(s): C. Torres, J. Kendrick	Date: 11/5/2020 Town: Holtville Photo begin file#:	Time: 0900-1030 State: CA Photo end file#:				
Y <input checked="" type="checkbox"/> / N <input type="checkbox"/> Do normal circumstances exist on the site? Y <input type="checkbox"/> / N <input checked="" type="checkbox"/> Is the site significantly disturbed?	Location Details: South of Salton Sea, directly south of All-American Canal and adjacent to US -Mexico border Projection: Datum: NAD83 Coordinates:					
Potential anthropogenic influences on the channel system: Site priorly used for agriculture and has been previously disturbed/alterd. Runoff from adjacent agricultural land collects and is concentrated in the Study Area. Manmade berms line the drainages. Drainage system within a palustrine wetland in western portion of site.						
Brief site description: The Study Area is downslope of the All-American Canal, which brings water from the Colorado River and likely feeds into the site. Runoff generally flows south from the direction of the All-American Canal and toward the U.S.-Mexico border						
Checklist of resources (if available): <table style="width: 100%; border: none;"> <tr> <td style="width: 50%; vertical-align: top;"> <input checked="" type="checkbox"/> Aerial photography Dates: 1953, 1996-2016 (historic aerials); 11/2020 (sUAS imagery) <input checked="" type="checkbox"/> Topographic maps <input type="checkbox"/> Geologic maps <input checked="" type="checkbox"/> Vegetation maps <input checked="" type="checkbox"/> Soils maps <input type="checkbox"/> Rainfall/precipitation maps <input type="checkbox"/> Existing delineation(s) for site <input checked="" type="checkbox"/> Global positioning system (GPS) <input type="checkbox"/> Other studies </td> <td style="width: 50%; vertical-align: top;"> <input type="checkbox"/> Stream gage data Gage number: Period of record: <input type="checkbox"/> History of recent effective discharges <input type="checkbox"/> Results of flood frequency analysis <input type="checkbox"/> Most recent shift-adjusted rating <input type="checkbox"/> Gage heights for 2-, 5-, 10-, and 25-year events and the most recent event exceeding a 5-year event </td> </tr> </table>			<input checked="" type="checkbox"/> Aerial photography Dates: 1953, 1996-2016 (historic aerials); 11/2020 (sUAS imagery) <input checked="" type="checkbox"/> Topographic maps <input type="checkbox"/> Geologic maps <input checked="" type="checkbox"/> Vegetation maps <input checked="" type="checkbox"/> Soils maps <input type="checkbox"/> Rainfall/precipitation maps <input type="checkbox"/> Existing delineation(s) for site <input checked="" type="checkbox"/> Global positioning system (GPS) <input type="checkbox"/> Other studies	<input type="checkbox"/> Stream gage data Gage number: Period of record: <input type="checkbox"/> History of recent effective discharges <input type="checkbox"/> Results of flood frequency analysis <input type="checkbox"/> Most recent shift-adjusted rating <input type="checkbox"/> Gage heights for 2-, 5-, 10-, and 25-year events and the most recent event exceeding a 5-year event		
<input checked="" type="checkbox"/> Aerial photography Dates: 1953, 1996-2016 (historic aerials); 11/2020 (sUAS imagery) <input checked="" type="checkbox"/> Topographic maps <input type="checkbox"/> Geologic maps <input checked="" type="checkbox"/> Vegetation maps <input checked="" type="checkbox"/> Soils maps <input type="checkbox"/> Rainfall/precipitation maps <input type="checkbox"/> Existing delineation(s) for site <input checked="" type="checkbox"/> Global positioning system (GPS) <input type="checkbox"/> Other studies	<input type="checkbox"/> Stream gage data Gage number: Period of record: <input type="checkbox"/> History of recent effective discharges <input type="checkbox"/> Results of flood frequency analysis <input type="checkbox"/> Most recent shift-adjusted rating <input type="checkbox"/> Gage heights for 2-, 5-, 10-, and 25-year events and the most recent event exceeding a 5-year event					
Hydrogeomorphic Floodplain Units 						
Procedure for identifying and characterizing the floodplain units to assist in identifying the OHWM: 1. Walk the channel and floodplain within the study area to get an impression of the geomorphology and vegetation present at the site. 2. Select a representative cross section across the channel. Draw the cross section and label the floodplain units. 3. Determine a point on the cross section that is characteristic of one of the hydrogeomorphic floodplain units. a) Record the floodplain unit and GPS position. b) Describe the sediment texture (using the Wentworth class size) and the vegetation characteristics of the floodplain unit. c) Identify any indicators present at the location. 4. Repeat for other points in different hydrogeomorphic floodplain units across the cross section. 5. Identify the OHWM and record the indicators. Record the OHWM position via:						
<table style="width: 100%; border: none;"> <tr> <td style="width: 50%;"><input type="checkbox"/> Mapping on aerial photograph</td> <td style="width: 50%;"><input checked="" type="checkbox"/> GPS</td> </tr> <tr> <td><input type="checkbox"/> Digitized on computer</td> <td><input type="checkbox"/> Other:</td> </tr> </table>			<input type="checkbox"/> Mapping on aerial photograph	<input checked="" type="checkbox"/> GPS	<input type="checkbox"/> Digitized on computer	<input type="checkbox"/> Other:
<input type="checkbox"/> Mapping on aerial photograph	<input checked="" type="checkbox"/> GPS					
<input type="checkbox"/> Digitized on computer	<input type="checkbox"/> Other:					

Cross section drawing:



OHWM

GPS point: 32.680418, -115.317431

Indicators:

- Change in average sediment texture
- Change in vegetation species
- Change in vegetation cover
- Break in bank slope
- Other: _____
- Other: _____

Comments:

Vegetated channel adjacent to one channel to the east and one channel to the west. Vegetation consists of tamarisk and arrow weed. Man-made berms line the channel.

Floodplain unit: Low-Flow Channel Active Floodplain Low Terrace

GPS point: 32.680418, -115.317431

Characteristics of the floodplain unit:

Average sediment texture: Medium sand/sand

Total veg cover: 70 % Tree: 10 % Shrub: 60 % Herb: 0 %

Community successional stage:

- NA
- Early (herbaceous & seedlings)
- Mid (herbaceous, shrubs, saplings)
- Late (herbaceous, shrubs, mature trees)

Indicators:

- Mudcracks
- Ripples
- Drift and/or debris
- Presence of bed and bank
- Benches
- Soil development
- Surface relief
- Other: _____
- Other: _____
- Other: _____

Comments:

Salt crust present, but likely from adjacent agricultural run-off. Water seems to flood over bank of channel to adjacent channels/wetland.

Arid West Ephemeral and Intermittent Streams OHW M Datasheet

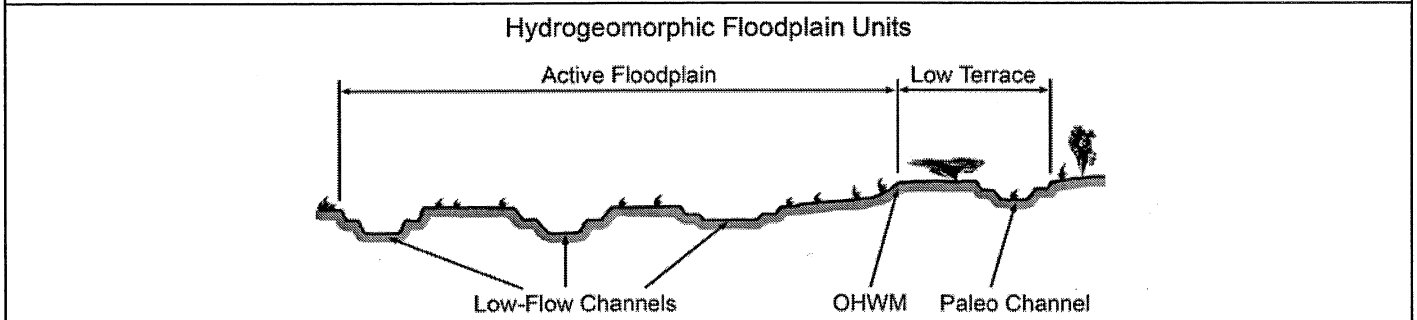
Project: Vega SES 4 Project Number: 2020-142 Stream: ED-3 Investigator(s): C. Torres, J. Kendrick	Date: 11/05/2020 Town: Holtville Photo begin file#:	Time: 0900-1030 State: CA Photo end file#:
Y <input checked="" type="checkbox"/> / N <input type="checkbox"/> Do normal circumstances exist on the site?	Location Details: South of Salton Sea, directly south of All-American Canal and north of US -Mexico border	
Y <input type="checkbox"/> / N <input checked="" type="checkbox"/> Is the site significantly disturbed?	Projection: Datum: NAD83 Coordinates:	

Potential anthropogenic influences on the channel system:
 Site priorly used for agriculture and has been previously disturbed/alterd. Runoff from adjacent agricultural land collects and is concentrated in the Study Area. Manmade berms line the drainages. Drainage system within a palustrine wetland in western portion of site.

Brief site description:
 The Study Area is downslope of the All-American Canal, which brings water from the Colorado River and likely feeds into the site. Runoff generally flows south from the direction of the All-American Canal and toward the U.S.-Mexico border

Checklist of resources (if available):

<input checked="" type="checkbox"/> Aerial photography Dates: 1953, 1996-2016 (historic aeriels); 11/2020 (sUAS imagery) <input checked="" type="checkbox"/> Topographic maps <input type="checkbox"/> Geologic maps <input checked="" type="checkbox"/> Vegetation maps <input checked="" type="checkbox"/> Soils maps <input type="checkbox"/> Rainfall/precipitation maps <input type="checkbox"/> Existing delineation(s) for site <input checked="" type="checkbox"/> Global positioning system (GPS) <input type="checkbox"/> Other studies	<input type="checkbox"/> Stream gage data Gage number: Period of record: <input type="checkbox"/> History of recent effective discharges <input type="checkbox"/> Results of flood frequency analysis <input type="checkbox"/> Most recent shift-adjusted rating <input type="checkbox"/> Gage heights for 2-, 5-, 10-, and 25-year events and the most recent event exceeding a 5-year event
------------------------------------------------------------------------------------------------------------------------------------------------------------------------------------------------------------------------------------------------------------------------------------------------------------------------------------------------------------------------------------------------------------------------------------------------------------------------------------------------------------------------------------------------------------------------------	-----------------------------------------------------------------------------------------------------------------------------------------------------------------------------------------------------------------------------------------------------------------------------------------------------------------------------------------------------------------------------------------------------------------

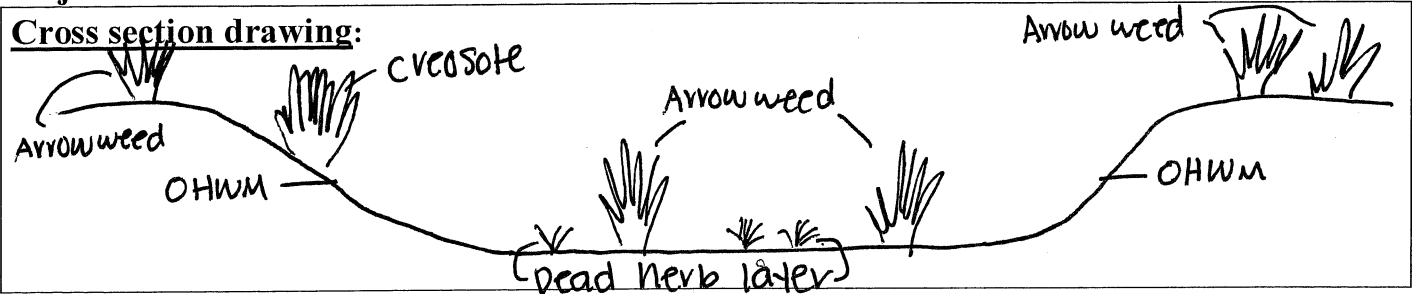


Procedure for identifying and characterizing the floodplain units to assist in identifying the OHWM:

1. Walk the channel and floodplain within the study area to get an impression of the geomorphology and vegetation present at the site.
2. Select a representative cross section across the channel. Draw the cross section and label the floodplain units.
3. Determine a point on the cross section that is characteristic of one of the hydrogeomorphic floodplain units.
 - a) Record the floodplain unit and GPS position.
 - b) Describe the sediment texture (using the Wentworth class size) and the vegetation characteristics of the floodplain unit.
 - c) Identify any indicators present at the location.
4. Repeat for other points in different hydrogeomorphic floodplain units across the cross section.
5. Identify the OHWM and record the indicators. Record the OHWM position via:

<input type="checkbox"/> Mapping on aerial photograph	<input checked="" type="checkbox"/> GPS
<input type="checkbox"/> Digitized on computer	<input type="checkbox"/> Other:

Cross section drawing:



OHWM

GPS point: 32.680503, -115.317320

Indicators:

- | | |
|----------------------------------------------------------------|---------------------------------------------------------|
| <input type="checkbox"/> Change in average sediment texture | <input checked="" type="checkbox"/> Break in bank slope |
| <input type="checkbox"/> Change in vegetation species | <input type="checkbox"/> Other: _____ |
| <input checked="" type="checkbox"/> Change in vegetation cover | <input type="checkbox"/> Other: _____ |

Comments:

Vegetated channel adjacent to another channel to the west. Vegetation consists of arrow weed within the channel. OHWM was slight.

Floodplain unit: Low-Flow Channel Active Floodplain Low Terrace

GPS point: 32.680503, -115.317320

Characteristics of the floodplain unit:

Average sediment texture: Medium sand/sand

Total veg cover: 35 % Tree: 0 % Shrub: 18 % Herb: 17 %

Community successional stage:

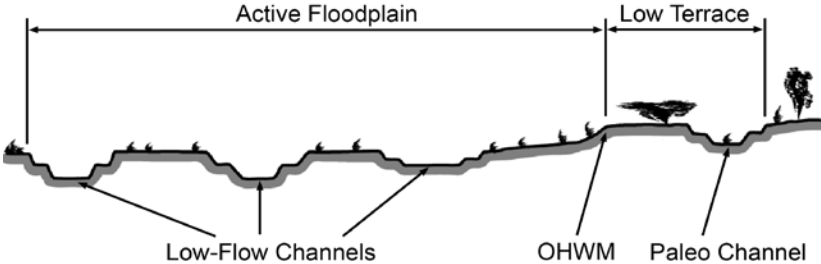
- | | |
|---------------------------------------------------------|-----------------------------------------------------------------------------|
| <input type="checkbox"/> NA | <input type="checkbox"/> Mid (herbaceous, shrubs, saplings) |
| <input type="checkbox"/> Early (herbaceous & seedlings) | <input checked="" type="checkbox"/> Late (herbaceous, shrubs, mature trees) |

Indicators:

- | | |
|--------------------------------------------------------------|------------------------------------------------------------------------------|
| <input type="checkbox"/> Mudcracks | <input type="checkbox"/> Soil development |
| <input type="checkbox"/> Ripples | <input type="checkbox"/> Surface relief |
| <input type="checkbox"/> Drift and/or debris | <input checked="" type="checkbox"/> Other: <u>Change in vegetation cover</u> |
| <input checked="" type="checkbox"/> Presence of bed and bank | <input type="checkbox"/> Other: _____ |
| <input type="checkbox"/> Benches | <input type="checkbox"/> Other: _____ |

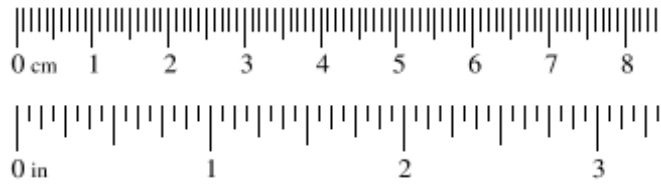
Comments:

Arid West Ephemeral and Intermittent Streams OHWM Datasheet

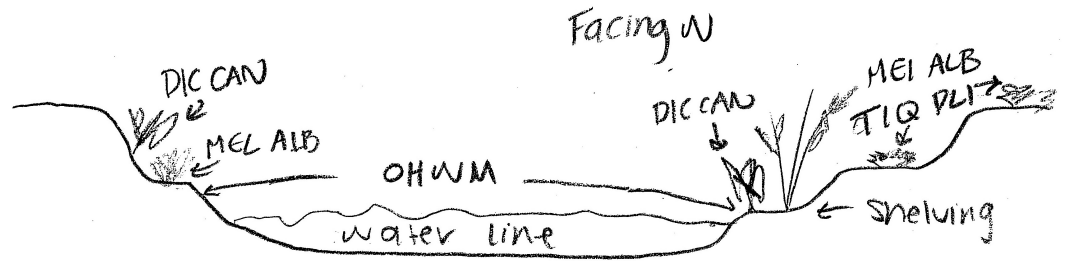
Project: Vega SES 4 Project Number: 2020-142 Stream: Offline Storage canal for All-American Canal Investigator(s): C. Torres, C. Garcia	Date: 4/12/2022 Town: Holtville Photo begin file#:	Time: 0900 State: CA Photo end file#:				
Y <input checked="" type="checkbox"/> / N <input type="checkbox"/> Do normal circumstances exist on the site? Y <input type="checkbox"/> / N <input checked="" type="checkbox"/> Is the site significantly disturbed?	Location Details: Offline storage canal, serving as a tributary to the All-American Canal to the south. Projection: _____ Datum: _____ Coordinates: _____					
Potential anthropogenic influences on the channel system: Trash and dumping. Canal is managed by IID, including flow.						
Brief site description: Natural-bottomed storage canal serving as a tributary to the All-American Canal located directly south. Both canals run parallel to the U.S./Mexico border. Cross-section taken at the Gordon Well Road bridge crossing.						
Checklist of resources (if available): <table style="width: 100%; border: none;"> <tr> <td style="width: 50%; vertical-align: top;"> <input checked="" type="checkbox"/> Aerial photography Dates: 1953-2019 <input checked="" type="checkbox"/> Topographic maps <input type="checkbox"/> Geologic maps <input type="checkbox"/> Vegetation maps <input checked="" type="checkbox"/> Soils maps <input checked="" type="checkbox"/> Rainfall/precipitation maps <input type="checkbox"/> Existing delineation(s) for site <input checked="" type="checkbox"/> Global positioning system (GPS) <input type="checkbox"/> Other studies </td> <td style="width: 50%; vertical-align: top;"> <input type="checkbox"/> Stream gage data Gage number: _____ Period of record: _____ <input type="checkbox"/> History of recent effective discharges <input type="checkbox"/> Results of flood frequency analysis <input type="checkbox"/> Most recent shift-adjusted rating <input type="checkbox"/> Gage heights for 2-, 5-, 10-, and 25-year events and the most recent event exceeding a 5-year event </td> </tr> </table>			<input checked="" type="checkbox"/> Aerial photography Dates: 1953-2019 <input checked="" type="checkbox"/> Topographic maps <input type="checkbox"/> Geologic maps <input type="checkbox"/> Vegetation maps <input checked="" type="checkbox"/> Soils maps <input checked="" type="checkbox"/> Rainfall/precipitation maps <input type="checkbox"/> Existing delineation(s) for site <input checked="" type="checkbox"/> Global positioning system (GPS) <input type="checkbox"/> Other studies	<input type="checkbox"/> Stream gage data Gage number: _____ Period of record: _____ <input type="checkbox"/> History of recent effective discharges <input type="checkbox"/> Results of flood frequency analysis <input type="checkbox"/> Most recent shift-adjusted rating <input type="checkbox"/> Gage heights for 2-, 5-, 10-, and 25-year events and the most recent event exceeding a 5-year event		
<input checked="" type="checkbox"/> Aerial photography Dates: 1953-2019 <input checked="" type="checkbox"/> Topographic maps <input type="checkbox"/> Geologic maps <input type="checkbox"/> Vegetation maps <input checked="" type="checkbox"/> Soils maps <input checked="" type="checkbox"/> Rainfall/precipitation maps <input type="checkbox"/> Existing delineation(s) for site <input checked="" type="checkbox"/> Global positioning system (GPS) <input type="checkbox"/> Other studies	<input type="checkbox"/> Stream gage data Gage number: _____ Period of record: _____ <input type="checkbox"/> History of recent effective discharges <input type="checkbox"/> Results of flood frequency analysis <input type="checkbox"/> Most recent shift-adjusted rating <input type="checkbox"/> Gage heights for 2-, 5-, 10-, and 25-year events and the most recent event exceeding a 5-year event					
Hydrogeomorphic Floodplain Units 						
Procedure for identifying and characterizing the floodplain units to assist in identifying the OHW: <ol style="list-style-type: none"> 1. Walk the channel and floodplain within the study area to get an impression of the geomorphology and vegetation present at the site. 2. Select a representative cross section across the channel. Draw the cross section and label the floodplain units. 3. Determine a point on the cross section that is characteristic of one of the hydrogeomorphic floodplain units. <ol style="list-style-type: none"> a) Record the floodplain unit and GPS position. b) Describe the sediment texture (using the Wentworth class size) and the vegetation characteristics of the floodplain unit. c) Identify any indicators present at the location. 4. Repeat for other points in different hydrogeomorphic floodplain units across the cross section. 5. Identify the OHW and record the indicators. Record the OHW position via: <table style="width: 100%; border: none; margin-top: 5px;"> <tr> <td style="width: 50%;"><input type="checkbox"/> Mapping on aerial photograph</td> <td style="width: 50%;"><input checked="" type="checkbox"/> GPS</td> </tr> <tr> <td><input type="checkbox"/> Digitized on computer</td> <td><input type="checkbox"/> Other:</td> </tr> </table> 			<input type="checkbox"/> Mapping on aerial photograph	<input checked="" type="checkbox"/> GPS	<input type="checkbox"/> Digitized on computer	<input type="checkbox"/> Other:
<input type="checkbox"/> Mapping on aerial photograph	<input checked="" type="checkbox"/> GPS					
<input type="checkbox"/> Digitized on computer	<input type="checkbox"/> Other:					

Wentworth Size Classes

Inches (in)	Millimeters (mm)	Wentworth size class
10.08	256	Boulder
2.56	64	Cobble
0.157	4	Pebble
0.079	2.00	Granule
0.039	1.00	Very coarse sand
0.020	0.50	Coarse sand
1/2 0.0098	0.25	Medium sand
1/4 0.005	0.125	Fine sand
1/8 0.0025	0.0625	Very fine sand
1/16 0.0012	0.031	Coarse silt
1/32 0.00061	0.0156	Medium silt
1/64 0.00031	0.0078	Fine silt
1/128 0.00015	0.0039	Very fine silt
		Clay



Cross section drawing:



OHWM

GPS point: 32.705570, -114.957454

Indicators:

- Change in average sediment texture
- Change in vegetation species
- Change in vegetation cover
- Break in bank slope
- Other: see comments
- Other: _____

Comments:

Additional OHWM indicators: shelving, natural line, scour, wracking, drift/debris, benches, ripples.
 OHWM width= 150'
 B2B width= 200'

Floodplain unit:

- Low-Flow Channel
- Active Floodplain
- Low Terrace

GPS point: 32.705570, -114.957454

Characteristics of the floodplain unit:

Average sediment texture: Fine sand
 Total veg cover: 3 % Tree: _____ % Shrub: 1 % Herb: 2 %
 Community successional stage:

- NA
- Early (herbaceous & seedlings)
- Mid (herbaceous, shrubs, saplings)
- Late (herbaceous, shrubs, mature trees)

Indicators:

- Mudcracks
- Ripples
- Drift and/or debris
- Presence of bed and bank
- Benches
- Soil development
- Surface relief
- Other: _____
- Other: _____
- Other: _____

Comments:

WETLAND DETERMINATION DATA FORM – Arid West Region

Project/Site: Vega SES 4 City/County: Holtville/ Imperial County Sampling Date: 11/4/2020
 Applicant/Owner: zGlobal, Inc. State: CA Sampling Point: 1
 Investigator(s): C. Congedo, C. Torres Section, Township, Range: S10, T17S, R16E
 Landform (hillslope, terrace, etc.): Depression Local relief (concave, convex, none): Concave Slope (%): 10
 Subregion (LRR): D Lat: 32.6818662 Long: -115.3161832 Datum: NAD83
 Soil Map Unit Name: Rositas sand, 2 to 5 percent slopes NWI classification: N/A

Are climatic / hydrologic conditions on the site typical for this time of year? Yes No (If no, explain in Remarks.)
 Are Vegetation , Soil , or Hydrology significantly disturbed? Are "Normal Circumstances" present? Yes No
 Are Vegetation , Soil , or Hydrology naturally problematic? (If needed, explain any answers in Remarks.)

SUMMARY OF FINDINGS – Attach site map showing sampling point locations, transects, important features, etc.

Hydrophytic Vegetation Present? Yes <input checked="" type="checkbox"/> No <input type="checkbox"/> Hydric Soil Present? Yes <input checked="" type="checkbox"/> No <input type="checkbox"/> Wetland Hydrology Present? Yes <input checked="" type="checkbox"/> No <input type="checkbox"/>	Is the Sampled Area within a Wetland? Yes <input checked="" type="checkbox"/> No <input type="checkbox"/>
Remarks: Point taken within tamarisk thickets, downslope (south) of a hard-packed dirt road that runs parallel to the All-American Canal.	

VEGETATION – Use scientific names of plants.

Tree Stratum (Plot size: <u>30'</u>)	Absolute % Cover	Dominant Species?	Indicator Status	
1. <u>Tamarix sp.</u>	<u>5</u>		<u>FAC</u>	Dominance Test worksheet: Number of Dominant Species That Are OBL, FACW, or FAC: <u>1</u> (A) Total Number of Dominant Species Across All Strata: <u>1</u> (B) Percent of Dominant Species That Are OBL, FACW, or FAC: <u>100</u> (A/B)
2. _____				
3. _____				
4. _____				
	<u>5</u>	= Total Cover		
Sapling/Shrub Stratum (Plot size: <u>30'</u>)				
1. <u>Pluchea sericea</u>	<u>20</u>	<u>x</u>	<u>FACW</u>	Prevalence Index worksheet: Total % Cover of: _____ Multiply by: _____ OBL species <u>0</u> x 1 = <u>0</u> FACW species <u>22</u> x 2 = <u>44</u> FAC species <u>5</u> x 3 = <u>15</u> FACU species <u>0</u> x 4 = <u>0</u> UPL species <u>0</u> x 5 = <u>0</u> Column Totals: <u>27</u> (A) <u>59</u> (B) Prevalence Index = B/A = <u>2.19</u>
2. <u>Baccharis salicina</u>	<u>2</u>		<u>FACW</u>	
3. _____				
4. _____				
5. _____				
	<u>22</u>	= Total Cover		
Herb Stratum (Plot size: _____)				
1. _____				Hydrophytic Vegetation Indicators: <input checked="" type="checkbox"/> Dominance Test is >50% <input checked="" type="checkbox"/> Prevalence Index is ≤3.0 ¹ <input type="checkbox"/> Morphological Adaptations ¹ (Provide supporting data in Remarks or on a separate sheet) <input type="checkbox"/> Problematic Hydrophytic Vegetation ¹ (Explain) ¹ Indicators of hydric soil and wetland hydrology must be present, unless disturbed or problematic.
2. _____				
3. _____				
4. _____				
5. _____				
6. _____				
7. _____				
8. _____				
	<u>0</u>	= Total Cover		
Woody Vine Stratum (Plot size: _____)				
1. _____				Hydrophytic Vegetation Present? Yes <input checked="" type="checkbox"/> No <input type="checkbox"/>
2. _____				
	<u>0</u>	= Total Cover		
% Bare Ground in Herb Stratum <u>73</u> % Cover of Biotic Crust _____				
Remarks:				

SOIL

Sampling Point: 1

Profile Description: (Describe to the depth needed to document the indicator or confirm the absence of indicators.)								
Depth (inches)	Matrix		Redox Features				Texture	Remarks
	Color (moist)	%	Color (moist)	%	Type ¹	Loc ²		
0-0.2	10YR 4/3	100					Loam	Organic material
0.2-2	10YR 5/4	100					Loam	Clayey layer
2-5	10YR 4/4	95	5YR 5/6	5	C	PL, M	Sandy loam	
5-13+	10YR 5/4	97	2.5YR 5/6	3	C	PL	Sand	
¹ Type: C=Concentration, D=Depletion, RM=Reduced Matrix, CS=Covered or Coated Sand Grains. ² Location: PL=Pore Lining, M=Matrix.								
Hydric Soil Indicators: (Applicable to all LRRs, unless otherwise noted.)						Indicators for Problematic Hydric Soils³:		
<input type="checkbox"/> Histosol (A1)			<input type="checkbox"/> Sandy Redox (S5)			<input type="checkbox"/> 1 cm Muck (A9) (LRR C)		
<input type="checkbox"/> Histic Epipedon (A2)			<input type="checkbox"/> Stripped Matrix (S6)			<input type="checkbox"/> 2 cm Muck (A10) (LRR B)		
<input type="checkbox"/> Black Histic (A3)			<input type="checkbox"/> Loamy Mucky Mineral (F1)			<input type="checkbox"/> Reduced Vertic (F18)		
<input type="checkbox"/> Hydrogen Sulfide (A4)			<input type="checkbox"/> Loamy Gleyed Matrix (F2)			<input type="checkbox"/> Red Parent Material (TF2)		
<input type="checkbox"/> Stratified Layers (A5) (LRR C)			<input type="checkbox"/> Depleted Matrix (F3)			<input type="checkbox"/> Other (Explain in Remarks)		
<input type="checkbox"/> 1 cm Muck (A9) (LRR D)			<input type="checkbox"/> Redox Dark Surface (F6)			³ Indicators of hydrophytic vegetation and wetland hydrology must be present, unless disturbed or problematic.		
<input type="checkbox"/> Depleted Below Dark Surface (A11)			<input type="checkbox"/> Depleted Dark Surface (F7)					
<input type="checkbox"/> Thick Dark Surface (A12)			<input checked="" type="checkbox"/> Redox Depressions (F8)					
<input type="checkbox"/> Sandy Mucky Mineral (S1)			<input type="checkbox"/> Vernal Pools (F9)					
<input type="checkbox"/> Sandy Gleyed Matrix (S4)								
Restrictive Layer (if present):						Hydric Soil Present? Yes <input checked="" type="checkbox"/> No <input type="checkbox"/>		
Type: _____								
Depth (inches): _____								
Remarks:								

HYDROLOGY

Wetland Hydrology Indicators:					
Primary Indicators (minimum of one required; check all that apply)			Secondary Indicators (2 or more required)		
<input type="checkbox"/> Surface Water (A1)	<input type="checkbox"/> Salt Crust (B11)	<input type="checkbox"/> Water Marks (B1) (Riverine)			
<input type="checkbox"/> High Water Table (A2)	<input type="checkbox"/> Biotic Crust (B12)	<input type="checkbox"/> Sediment Deposits (B2) (Riverine)			
<input checked="" type="checkbox"/> Saturation (A3)	<input type="checkbox"/> Aquatic Invertebrates (B13)	<input type="checkbox"/> Drift Deposits (B3) (Riverine)			
<input type="checkbox"/> Water Marks (B1) (Nonriverine)	<input type="checkbox"/> Hydrogen Sulfide Odor (C1)	<input type="checkbox"/> Drainage Patterns (B10)			
<input type="checkbox"/> Sediment Deposits (B2) (Nonriverine)	<input type="checkbox"/> Oxidized Rhizospheres along Living Roots (C3)	<input type="checkbox"/> Dry-Season Water Table (C2)			
<input type="checkbox"/> Drift Deposits (B3) (Nonriverine)	<input type="checkbox"/> Presence of Reduced Iron (C4)	<input type="checkbox"/> Crayfish Burrows (C8)			
<input checked="" type="checkbox"/> Surface Soil Cracks (B6)	<input type="checkbox"/> Recent Iron Reduction in Tilled Soils (C6)	<input type="checkbox"/> Saturation Visible on Aerial Imagery (C9)			
<input type="checkbox"/> Inundation Visible on Aerial Imagery (B7)	<input type="checkbox"/> Thin Muck Surface (C7)	<input type="checkbox"/> Shallow Aquitard (D3)			
<input type="checkbox"/> Water-Stained Leaves (B9)	<input type="checkbox"/> Other (Explain in Remarks)	<input type="checkbox"/> FAC-Neutral Test (D5)			
Field Observations:					
Surface Water Present?	Yes <input type="checkbox"/> No <input checked="" type="checkbox"/>	Depth (inches): _____	Wetland Hydrology Present? Yes <input checked="" type="checkbox"/> No <input type="checkbox"/>		
Water Table Present?	Yes <input type="checkbox"/> No <input checked="" type="checkbox"/>	Depth (inches): _____			
Saturation Present? (includes capillary fringe)	Yes <input checked="" type="checkbox"/> No <input type="checkbox"/>	Depth (inches): 0			
Describe Recorded Data (stream gauge, monitoring well, aerial photos, previous inspections), if available:					
Remarks:					
Salt crust, but could be from agricultural run-off.					

WETLAND DETERMINATION DATA FORM – Arid West Region

Project/Site: Vega SES 4 City/County: Holtville/ Imperial County Sampling Date: 11/4/2020
 Applicant/Owner: zGlobal, Inc. State: CA Sampling Point: 2
 Investigator(s): C. Congedo, C. Torres Section, Township, Range: S10, T17S, R16E
 Landform (hillslope, terrace, etc.): Channel Local relief (concave, convex, none): Concave Slope (%): 25
 Subregion (LRR): D Lat: 32.680633 Long: -115.318002 Datum: NAD83
 Soil Map Unit Name: Vint loamy very fine sand, wet NWI classification: N/A

Are climatic / hydrologic conditions on the site typical for this time of year? Yes No (If no, explain in Remarks.)
 Are Vegetation , Soil , or Hydrology significantly disturbed? Are "Normal Circumstances" present? Yes No
 Are Vegetation , Soil , or Hydrology naturally problematic? (If needed, explain any answers in Remarks.)

SUMMARY OF FINDINGS – Attach site map showing sampling point locations, transects, important features, etc.

Hydrophytic Vegetation Present? Yes <input checked="" type="checkbox"/> No <input type="checkbox"/> Hydric Soil Present? Yes <input checked="" type="checkbox"/> No <input type="checkbox"/> Wetland Hydrology Present? Yes <input checked="" type="checkbox"/> No <input type="checkbox"/>	Is the Sampled Area within a Wetland? Yes <input checked="" type="checkbox"/> No <input type="checkbox"/>
Remarks: Point taken within emergent wetland in the bed of a drainage.	

VEGETATION – Use scientific names of plants.

Tree Stratum (Plot size: <u>10'</u>)	Absolute % Cover	Dominant Species?	Indicator Status	
1. <u>Tamarix sp.</u>	<u>5</u>		<u>FAC</u>	Dominance Test worksheet: Number of Dominant Species That Are OBL, FACW, or FAC: <u>1</u> (A) Total Number of Dominant Species Across All Strata: <u>1</u> (B) Percent of Dominant Species That Are OBL, FACW, or FAC: <u>100</u> (A/B)
2. _____				
3. _____				
4. _____				
<u>5</u> = Total Cover				Prevalence Index worksheet: Total % Cover of: _____ Multiply by: _____ OBL species <u>65</u> x 1 = <u>65</u> FACW species <u>0</u> x 2 = <u>0</u> FAC species <u>5</u> x 3 = <u>15</u> FACU species <u>0</u> x 4 = <u>0</u> UPL species <u>0</u> x 5 = <u>0</u> Column Totals: <u>70</u> (A) <u>80</u> (B) Prevalence Index = B/A = <u>1.14</u>
Sapling/Shrub Stratum (Plot size: <u>10'</u>)				
1. <u>Typha sp.</u>	<u>65</u>	<u>x</u>	<u>OBL</u>	
2. _____				
3. _____				
4. _____				
5. _____				
<u>65</u> = Total Cover				
Herb Stratum (Plot size: _____)				
1. _____				
2. _____				
3. _____				
4. _____				
5. _____				
6. _____				
7. _____				
8. _____				
<u>0</u> = Total Cover				
Woody Vine Stratum (Plot size: _____)				
1. _____				
2. _____				
<u>0</u> = Total Cover				
% Bare Ground in Herb Stratum <u>35</u>		% Cover of Biotic Crust _____		
Hydrophytic Vegetation Indicators: <input checked="" type="checkbox"/> Dominance Test is >50% <input checked="" type="checkbox"/> Prevalence Index is ≤3.0 ¹ <input type="checkbox"/> Morphological Adaptations ¹ (Provide supporting data in Remarks or on a separate sheet) <input type="checkbox"/> Problematic Hydrophytic Vegetation ¹ (Explain)				
¹ Indicators of hydric soil and wetland hydrology must be present, unless disturbed or problematic.				
Hydrophytic Vegetation Present? Yes <input checked="" type="checkbox"/> No <input type="checkbox"/>				
Remarks:				

SOIL

Sampling Point: 2

Profile Description: (Describe to the depth needed to document the indicator or confirm the absence of indicators.)								
Depth (inches)	Matrix		Redox Features				Texture	Remarks
	Color (moist)	%	Color (moist)	%	Type ¹	Loc ²		
0-1	10YR 2/2	100						Organic material- muck (greasy)
1-6	10YR 6/2	92	Gley 1, 2.5/N	3	C	M	Loam	Iron manganese masses
1-6			5YR 5/8	5	C	PL, M		
6-13+	Gley 1, 5/N	70					Silty clay ^h	
	Gley 1, 4/N	30					Silty clay ^h	
¹ Type: C=Concentration, D=Depletion, RM=Reduced Matrix, CS=Covered or Coated Sand Grains. ² Location: PL=Pore Lining, M=Matrix.								
Hydric Soil Indicators: (Applicable to all LRRs, unless otherwise noted.)						Indicators for Problematic Hydric Soils³:		
<input type="checkbox"/> Histosol (A1)			<input type="checkbox"/> Sandy Redox (S5)			<input type="checkbox"/> 1 cm Muck (A9) (LRR C)		
<input type="checkbox"/> Histic Epipedon (A2)			<input type="checkbox"/> Stripped Matrix (S6)			<input type="checkbox"/> 2 cm Muck (A10) (LRR B)		
<input type="checkbox"/> Black Histic (A3)			<input type="checkbox"/> Loamy Mucky Mineral (F1)			<input type="checkbox"/> Reduced Vertic (F18)		
<input checked="" type="checkbox"/> Hydrogen Sulfide (A4)			<input checked="" type="checkbox"/> Loamy Gleyed Matrix (F2)			<input type="checkbox"/> Red Parent Material (TF2)		
<input type="checkbox"/> Stratified Layers (A5) (LRR C)			<input type="checkbox"/> Depleted Matrix (F3)			<input type="checkbox"/> Other (Explain in Remarks)		
<input type="checkbox"/> 1 cm Muck (A9) (LRR D)			<input type="checkbox"/> Redox Dark Surface (F6)			³ Indicators of hydrophytic vegetation and wetland hydrology must be present, unless disturbed or problematic.		
<input type="checkbox"/> Depleted Below Dark Surface (A11)			<input type="checkbox"/> Depleted Dark Surface (F7)					
<input type="checkbox"/> Thick Dark Surface (A12)			<input checked="" type="checkbox"/> Redox Depressions (F8)					
<input type="checkbox"/> Sandy Mucky Mineral (S1)			<input type="checkbox"/> Vernal Pools (F9)					
<input type="checkbox"/> Sandy Gleyed Matrix (S4)								
Restrictive Layer (if present):								
Type: _____								
Depth (inches): _____						Hydric Soil Present? Yes <input checked="" type="checkbox"/> No <input type="checkbox"/>		
Remarks:								

HYDROLOGY

Wetland Hydrology Indicators:		
Primary Indicators (minimum of one required; check all that apply)	Secondary Indicators (2 or more required)	
<input checked="" type="checkbox"/> Surface Water (A1)	<input type="checkbox"/> Salt Crust (B11)	<input type="checkbox"/> Water Marks (B1) (Riverine)
<input checked="" type="checkbox"/> High Water Table (A2)	<input type="checkbox"/> Biotic Crust (B12)	<input type="checkbox"/> Sediment Deposits (B2) (Riverine)
<input checked="" type="checkbox"/> Saturation (A3)	<input type="checkbox"/> Aquatic Invertebrates (B13)	<input type="checkbox"/> Drift Deposits (B3) (Riverine)
<input type="checkbox"/> Water Marks (B1) (Nonriverine)	<input checked="" type="checkbox"/> Hydrogen Sulfide Odor (C1)	<input type="checkbox"/> Drainage Patterns (B10)
<input type="checkbox"/> Sediment Deposits (B2) (Nonriverine)	<input type="checkbox"/> Oxidized Rhizospheres along Living Roots (C3)	<input type="checkbox"/> Dry-Season Water Table (C2)
<input type="checkbox"/> Drift Deposits (B3) (Nonriverine)	<input type="checkbox"/> Presence of Reduced Iron (C4)	<input type="checkbox"/> Crayfish Burrows (C8)
<input type="checkbox"/> Surface Soil Cracks (B6)	<input type="checkbox"/> Recent Iron Reduction in Tilled Soils (C6)	<input type="checkbox"/> Saturation Visible on Aerial Imagery (C9)
<input type="checkbox"/> Inundation Visible on Aerial Imagery (B7)	<input type="checkbox"/> Thin Muck Surface (C7)	<input type="checkbox"/> Shallow Aquitard (D3)
<input type="checkbox"/> Water-Stained Leaves (B9)	<input type="checkbox"/> Other (Explain in Remarks)	<input type="checkbox"/> FAC-Neutral Test (D5)
Field Observations:		
Surface Water Present?	Yes <input checked="" type="checkbox"/> No <input type="checkbox"/>	Depth (inches): <u>3</u>
Water Table Present?	Yes <input checked="" type="checkbox"/> No <input type="checkbox"/>	Depth (inches): <u>0</u>
Saturation Present? (includes capillary fringe)	Yes <input checked="" type="checkbox"/> No <input type="checkbox"/>	Depth (inches): <u>0</u>
		Wetland Hydrology Present? Yes <input checked="" type="checkbox"/> No <input type="checkbox"/>
Describe Recorded Data (stream gauge, monitoring well, aerial photos, previous inspections), if available:		
Remarks:		

WETLAND DETERMINATION DATA FORM – Arid West Region

Project/Site: Vega SES 4 City/County: Holtville/ Imperial County Sampling Date: 11/5/2020
 Applicant/Owner: zGlobal, Inc. State: CA Sampling Point: 6
 Investigator(s): C. Congedo, C. Torres Section, Township, Range: S11, T17S, R16E
 Landform (hillslope, terrace, etc.): Depression Local relief (concave, convex, none): None Slope (%): 5
 Subregion (LRR): D Lat: 32.687512 Long: -115.302089 Datum: NAD83
 Soil Map Unit Name: Rositas fine sand, wet, 0 to 2 percent slopes NWI classification: N/A

Are climatic / hydrologic conditions on the site typical for this time of year? Yes No (If no, explain in Remarks.)
 Are Vegetation , Soil , or Hydrology significantly disturbed? Are "Normal Circumstances" present? Yes No
 Are Vegetation , Soil , or Hydrology naturally problematic? (If needed, explain any answers in Remarks.)

SUMMARY OF FINDINGS – Attach site map showing sampling point locations, transects, important features, etc.

Hydrophytic Vegetation Present? Yes <input checked="" type="checkbox"/> No <input type="checkbox"/> Hydric Soil Present? Yes <input type="checkbox"/> No <input checked="" type="checkbox"/> Wetland Hydrology Present? Yes <input checked="" type="checkbox"/> No <input type="checkbox"/>	Is the Sampled Area within a Wetland? Yes <input type="checkbox"/> No <input checked="" type="checkbox"/>
Remarks:	

VEGETATION – Use scientific names of plants.

Tree Stratum (Plot size: _____)	Absolute % Cover	Dominant Species?	Indicator Status	
1. _____	_____	_____	_____	Dominance Test worksheet: Number of Dominant Species That Are OBL, FACW, or FAC: <u>1</u> (A) Total Number of Dominant Species Across All Strata: <u>1</u> (B) Percent of Dominant Species That Are OBL, FACW, or FAC: <u>100</u> (A/B)
2. _____	_____	_____	_____	
3. _____	_____	_____	_____	
4. _____	_____	_____	_____	
_____ = Total Cover				Prevalence Index worksheet: Total % Cover of: _____ Multiply by: _____ OBL species <u>0</u> x 1 = <u>0</u> FACW species <u>5</u> x 2 = <u>10</u> FAC species <u>0</u> x 3 = <u>0</u> FACU species <u>0</u> x 4 = <u>0</u> UPL species <u>0</u> x 5 = <u>0</u> Column Totals: <u>5</u> (A) <u>10</u> (B) Prevalence Index = B/A = <u>2.0</u>
Sapling/Shrub Stratum (Plot size: <u>15'</u>)				
1. <u>Pluchea sericea</u>	<u>5</u>	<u>x</u>	<u>FACW</u>	
2. _____	_____	_____	_____	
3. _____	_____	_____	_____	
4. _____	_____	_____	_____	
5. _____	_____	_____	_____	
_____ = Total Cover				
Herb Stratum (Plot size: _____)				
1. _____	_____	_____	_____	
2. _____	_____	_____	_____	
3. _____	_____	_____	_____	
4. _____	_____	_____	_____	
5. _____	_____	_____	_____	
6. _____	_____	_____	_____	
7. _____	_____	_____	_____	
8. _____	_____	_____	_____	
_____ = Total Cover				
Woody Vine Stratum (Plot size: _____)				
1. _____	_____	_____	_____	
2. _____	_____	_____	_____	
_____ = Total Cover				
% Bare Ground in Herb Stratum <u>95</u> % Cover of Biotic Crust _____				
Remarks:				

¹Indicators of hydric soil and wetland hydrology must be present, unless disturbed or problematic.

SOIL

Sampling Point: 6

Profile Description: (Describe to the depth needed to document the indicator or confirm the absence of indicators.)

Depth (inches)	Matrix		Redox Features				Texture	Remarks
	Color (moist)	%	Color (moist)	%	Type ¹	Loc ²		
0-13	7.5YR 4/4	100					Sandy loam	
13-14	10YR 7/3	85	2.5YR 4/8	5			Silty clay	
13-14	Gley 1, 3/N	10					Silty clay	

¹Type: C=Concentration, D=Depletion, RM=Reduced Matrix, CS=Covered or Coated Sand Grains. ²Location: PL=Pore Lining, M=Matrix.

Hydric Soil Indicators: (Applicable to all LRRs, unless otherwise noted.)

Indicators for Problematic Hydric Soils³:

- Histosol (A1)
- Histic Epipedon (A2)
- Black Histic (A3)
- Hydrogen Sulfide (A4)
- Stratified Layers (A5) (LRR C)
- 1 cm Muck (A9) (LRR D)
- Depleted Below Dark Surface (A11)
- Thick Dark Surface (A12)
- Sandy Mucky Mineral (S1)
- Sandy Gleyed Matrix (S4)

- Sandy Redox (S5)
- Stripped Matrix (S6)
- Loamy Mucky Mineral (F1)
- Loamy Gleyed Matrix (F2)
- Depleted Matrix (F3)
- Redox Dark Surface (F6)
- Depleted Dark Surface (F7)
- Redox Depressions (F8)
- Vernal Pools (F9)

- 1 cm Muck (A9) (LRR C)
- 2 cm Muck (A10) (LRR B)
- Reduced Vertic (F18)
- Red Parent Material (TF2)
- Other (Explain in Remarks)

³Indicators of hydrophytic vegetation and wetland hydrology must be present, unless disturbed or problematic.

Restrictive Layer (if present):

Type: _____
Depth (inches): _____

Hydric Soil Present? Yes _____ No

Remarks:

HYDROLOGY

Wetland Hydrology Indicators:

Primary Indicators (minimum of one required; check all that apply)		Secondary Indicators (2 or more required)
<input type="checkbox"/> Surface Water (A1)	<input type="checkbox"/> Salt Crust (B11)	<input type="checkbox"/> Water Marks (B1) (Riverine)
<input type="checkbox"/> High Water Table (A2)	<input type="checkbox"/> Biotic Crust (B12)	<input type="checkbox"/> Sediment Deposits (B2) (Riverine)
<input checked="" type="checkbox"/> Saturation (A3)	<input type="checkbox"/> Aquatic Invertebrates (B13)	<input type="checkbox"/> Drift Deposits (B3) (Riverine)
<input type="checkbox"/> Water Marks (B1) (Nonriverine)	<input type="checkbox"/> Hydrogen Sulfide Odor (C1)	<input type="checkbox"/> Drainage Patterns (B10)
<input type="checkbox"/> Sediment Deposits (B2) (Nonriverine)	<input type="checkbox"/> Oxidized Rhizospheres along Living Roots (C3)	<input type="checkbox"/> Dry-Season Water Table (C2)
<input type="checkbox"/> Drift Deposits (B3) (Nonriverine)	<input type="checkbox"/> Presence of Reduced Iron (C4)	<input type="checkbox"/> Crayfish Burrows (C8)
<input type="checkbox"/> Surface Soil Cracks (B6)	<input type="checkbox"/> Recent Iron Reduction in Tilled Soils (C6)	<input type="checkbox"/> Saturation Visible on Aerial Imagery (C9)
<input type="checkbox"/> Inundation Visible on Aerial Imagery (B7)	<input type="checkbox"/> Thin Muck Surface (C7)	<input type="checkbox"/> Shallow Aquitard (D3)
<input type="checkbox"/> Water-Stained Leaves (B9)	<input type="checkbox"/> Other (Explain in Remarks)	<input checked="" type="checkbox"/> FAC-Neutral Test (D5)

Field Observations:

Surface Water Present? Yes _____ No _____ Depth (inches): _____
 Water Table Present? Yes _____ No _____ Depth (inches): _____
 Saturation Present? Yes No _____ Depth (inches): 0
 (includes capillary fringe)

Wetland Hydrology Present? Yes No _____

Describe Recorded Data (stream gauge, monitoring well, aerial photos, previous inspections), if available:

Remarks:

Salt crust present from agricultural run-off.

WETLAND DETERMINATION DATA FORM – Arid West Region

Project/Site: Vega SES 4 City/County: Holtville/ Imperial County Sampling Date: 11/5/2020
 Applicant/Owner: zGlobal, Inc. State: CA Sampling Point: 7
 Investigator(s): C. Congedo Section, Township, Range: S11, T17S, R16E
 Landform (hillslope, terrace, etc.): Depression Local relief (concave, convex, none): None Slope (%): 5
 Subregion (LRR): D Lat: 32.687200 Long: -115.302318 Datum: NAD83
 Soil Map Unit Name: Rositas fine sand, wet, 0 to 2 percent slopes NWI classification: N/A

Are climatic / hydrologic conditions on the site typical for this time of year? Yes No (If no, explain in Remarks.)
 Are Vegetation , Soil , or Hydrology significantly disturbed? Are "Normal Circumstances" present? Yes No
 Are Vegetation , Soil , or Hydrology naturally problematic? (If needed, explain any answers in Remarks.)

SUMMARY OF FINDINGS – Attach site map showing sampling point locations, transects, important features, etc.

Hydrophytic Vegetation Present? Yes <input checked="" type="checkbox"/> No <input type="checkbox"/> Hydric Soil Present? Yes <input checked="" type="checkbox"/> No <input type="checkbox"/> Wetland Hydrology Present? Yes <input checked="" type="checkbox"/> No <input type="checkbox"/>	Is the Sampled Area within a Wetland? Yes <input checked="" type="checkbox"/> No <input type="checkbox"/>
Remarks: Point taken within tamarisk thickets, downslope (south) of a hard-packed dirt road that runs parallel to the All-American Canal.	

VEGETATION – Use scientific names of plants.

Tree Stratum (Plot size: _____)	Absolute % Cover	Dominant Species?	Indicator Status	
1. _____	_____	_____	_____	Dominance Test worksheet: Number of Dominant Species That Are OBL, FACW, or FAC: <u>1</u> (A) Total Number of Dominant Species Across All Strata: <u>1</u> (B) Percent of Dominant Species That Are OBL, FACW, or FAC: <u>100</u> (A/B)
2. _____	_____	_____	_____	
3. _____	_____	_____	_____	
4. _____	_____	_____	_____	
_____ = Total Cover				Prevalence Index worksheet: Total % Cover of: _____ Multiply by: _____ OBL species <u>8</u> x 1 = <u>8</u> FACW species <u>10</u> x 2 = <u>20</u> FAC species <u>0</u> x 3 = <u>0</u> FACU species <u>0</u> x 4 = <u>0</u> UPL species <u>0</u> x 5 = <u>0</u> Column Totals: <u>18</u> (A) <u>28</u> (B) Prevalence Index = B/A = <u>1.56</u>
Sapling/Shrub Stratum (Plot size: <u>15'</u>)				
1. <u>Pluchea sericea</u>	<u>5</u>		<u>FACW</u>	
2. <u>Baccharis salicina</u>	<u>5</u>		<u>FACW</u>	
3. _____	_____	_____	_____	
4. _____	_____	_____	_____	
5. _____	_____	_____	_____	
_____ = Total Cover				
Herb Stratum (Plot size: <u>15'</u>)				
1. <u>Typha sp.</u>	<u>8</u>	<u>x</u>	<u>OBL</u>	
2. _____	_____	_____	_____	
3. _____	_____	_____	_____	
4. _____	_____	_____	_____	
5. _____	_____	_____	_____	
6. _____	_____	_____	_____	
7. _____	_____	_____	_____	
8. _____	_____	_____	_____	
_____ = Total Cover				
Woody Vine Stratum (Plot size: _____)				
1. _____	_____	_____	_____	
2. _____	_____	_____	_____	
_____ = Total Cover				
% Bare Ground in Herb Stratum <u>82</u> % Cover of Biotic Crust _____				
Remarks:				

¹Indicators of hydric soil and wetland hydrology must be present, unless disturbed or problematic.

Hydrophytic Vegetation Present? Yes No

SOIL

Sampling Point: 7

Profile Description: (Describe to the depth needed to document the indicator or confirm the absence of indicators.)								
Depth (inches)	Matrix		Redox Features				Texture	Remarks
	Color (moist)	%	Color (moist)	%	Type ¹	Loc ²		
0-6	10YR 5/3	92	7.5YR 5/8	8	C	M, PL	Sandy loam	
6-13+	10YR 6/2	100					Sand	

¹Type: C=Concentration, D=Depletion, RM=Reduced Matrix, CS=Covered or Coated Sand Grains. ²Location: PL=Pore Lining, M=Matrix.

Hydric Soil Indicators: (Applicable to all LRRs, unless otherwise noted.)			Indicators for Problematic Hydric Soils ³ :		
<input type="checkbox"/> Histosol (A1)	<input type="checkbox"/> Sandy Redox (S5)	<input type="checkbox"/> 1 cm Muck (A9) (LRR C)			
<input type="checkbox"/> Histic Epipedon (A2)	<input type="checkbox"/> Stripped Matrix (S6)	<input type="checkbox"/> 2 cm Muck (A10) (LRR B)			
<input type="checkbox"/> Black Histic (A3)	<input type="checkbox"/> Loamy Mucky Mineral (F1)	<input type="checkbox"/> Reduced Vertic (F18)			
<input type="checkbox"/> Hydrogen Sulfide (A4)	<input type="checkbox"/> Loamy Gleyed Matrix (F2)	<input type="checkbox"/> Red Parent Material (TF2)			
<input type="checkbox"/> Stratified Layers (A5) (LRR C)	<input type="checkbox"/> Depleted Matrix (F3)	<input type="checkbox"/> Other (Explain in Remarks)			
<input type="checkbox"/> 1 cm Muck (A9) (LRR D)	<input type="checkbox"/> Redox Dark Surface (F6)				
<input type="checkbox"/> Depleted Below Dark Surface (A11)	<input type="checkbox"/> Depleted Dark Surface (F7)				
<input type="checkbox"/> Thick Dark Surface (A12)	<input checked="" type="checkbox"/> Redox Depressions (F8)				
<input type="checkbox"/> Sandy Mucky Mineral (S1)	<input type="checkbox"/> Vernal Pools (F9)				
<input type="checkbox"/> Sandy Gleyed Matrix (S4)					

³Indicators of hydrophytic vegetation and wetland hydrology must be present, unless disturbed or problematic.

Restrictive Layer (if present): Type: _____ Depth (inches): _____	Hydric Soil Present? Yes <input checked="" type="checkbox"/> No _____
--------------------------------------------------------------------------------	------------------------------------------------------------------------------

Remarks:
Soil saturated throughout

HYDROLOGY

Wetland Hydrology Indicators:		
Primary Indicators (minimum of one required; check all that apply)	Secondary Indicators (2 or more required)	
<input type="checkbox"/> Surface Water (A1)	<input type="checkbox"/> Salt Crust (B11)	<input type="checkbox"/> Water Marks (B1) (Riverine)
<input type="checkbox"/> High Water Table (A2)	<input type="checkbox"/> Biotic Crust (B12)	<input type="checkbox"/> Sediment Deposits (B2) (Riverine)
<input checked="" type="checkbox"/> Saturation (A3)	<input type="checkbox"/> Aquatic Invertebrates (B13)	<input type="checkbox"/> Drift Deposits (B3) (Riverine)
<input type="checkbox"/> Water Marks (B1) (Nonriverine)	<input type="checkbox"/> Hydrogen Sulfide Odor (C1)	<input type="checkbox"/> Drainage Patterns (B10)
<input type="checkbox"/> Sediment Deposits (B2) (Nonriverine)	<input type="checkbox"/> Oxidized Rhizospheres along Living Roots (C3)	<input type="checkbox"/> Dry-Season Water Table (C2)
<input type="checkbox"/> Drift Deposits (B3) (Nonriverine)	<input type="checkbox"/> Presence of Reduced Iron (C4)	<input type="checkbox"/> Crayfish Burrows (C8)
<input type="checkbox"/> Surface Soil Cracks (B6)	<input type="checkbox"/> Recent Iron Reduction in Tilled Soils (C6)	<input type="checkbox"/> Saturation Visible on Aerial Imagery (C9)
<input type="checkbox"/> Inundation Visible on Aerial Imagery (B7)	<input type="checkbox"/> Thin Muck Surface (C7)	<input type="checkbox"/> Shallow Aquitard (D3)
<input checked="" type="checkbox"/> Water-Stained Leaves (B9)	<input type="checkbox"/> Other (Explain in Remarks)	<input type="checkbox"/> FAC-Neutral Test (D5)

Field Observations: Surface Water Present? Yes _____ No <input checked="" type="checkbox"/> Depth (inches): _____ Water Table Present? Yes _____ No <input checked="" type="checkbox"/> Depth (inches): _____ Saturation Present? (includes capillary fringe) Yes <input checked="" type="checkbox"/> No _____ Depth (inches): 0	Wetland Hydrology Present? Yes <input checked="" type="checkbox"/> No _____
--------------------------------------------------------------------------------------------------------------------------------------------------------------------------------------------------------------------------------------------------------------------------------------------------------------------------------------------------------------	------------------------------------------------------------------------------------

Describe Recorded Data (stream gauge, monitoring well, aerial photos, previous inspections), if available:

Remarks:

WETLAND DETERMINATION DATA FORM – Arid West Region

Project/Site: Vega SES 4 City/County: Holtville/ Imperial County Sampling Date: 11/5/2020
 Applicant/Owner: zGlobal, Inc. State: CA Sampling Point: 9
 Investigator(s): C. Congedo Section, Township, Range: S11, T17S, R16E
 Landform (hillslope, terrace, etc.): Depression Local relief (concave, convex, none): None Slope (%): 5
 Subregion (LRR): D Lat: 32.683380 Long: -115.303826 Datum: NAD83
 Soil Map Unit Name: Rositas fine sand, 0 to 2 percent slopes NWI classification: N/A

Are climatic / hydrologic conditions on the site typical for this time of year? Yes No (If no, explain in Remarks.)
 Are Vegetation , Soil , or Hydrology significantly disturbed? Are "Normal Circumstances" present? Yes No
 Are Vegetation , Soil , or Hydrology naturally problematic? (If needed, explain any answers in Remarks.)

SUMMARY OF FINDINGS – Attach site map showing sampling point locations, transects, important features, etc.

Hydrophytic Vegetation Present? Yes <input checked="" type="checkbox"/> No <input type="checkbox"/> Hydric Soil Present? Yes <input type="checkbox"/> No <input checked="" type="checkbox"/> Wetland Hydrology Present? Yes <input checked="" type="checkbox"/> No <input type="checkbox"/>	Is the Sampled Area within a Wetland? Yes <input type="checkbox"/> No <input checked="" type="checkbox"/>
Remarks: Point taken within a slight depression in tamarisk thickets, ~1230 feet downslope (south) of a hard-packed dirt road that runs parallel to the All-American Canal.	

VEGETATION – Use scientific names of plants.

Tree Stratum (Plot size: <u>15'</u>)	Absolute % Cover	Dominant Species?	Indicator Status	
1. <u>Tamarix sp.</u>	<u>2</u>		<u>FAC</u>	Dominance Test worksheet: Number of Dominant Species That Are OBL, FACW, or FAC: <u>1</u> (A) Total Number of Dominant Species Across All Strata: <u>1</u> (B) Percent of Dominant Species That Are OBL, FACW, or FAC: <u>100</u> (A/B)
2. _____				
3. _____				
4. _____				
	<u>2</u>	= Total Cover		
Sapling/Shrub Stratum (Plot size: <u>15'</u>)				
1. <u>Pluchea sericea</u>	<u>10</u>	<u>x</u>	<u>FACW</u>	Prevalence Index worksheet: Total % Cover of: _____ Multiply by: _____ OBL species <u>0</u> x 1 = <u>0</u> FACW species <u>10</u> x 2 = <u>20</u> FAC species <u>2</u> x 3 = <u>6</u> FACU species <u>0</u> x 4 = <u>0</u> UPL species <u>0</u> x 5 = <u>0</u> Column Totals: <u>12</u> (A) <u>26</u> (B) Prevalence Index = B/A = <u>2.17</u>
2. _____				
3. _____				
4. _____				
5. _____				
	<u>10</u>	= Total Cover		
Herb Stratum (Plot size: _____)				
1. _____				Hydrophytic Vegetation Indicators: <input checked="" type="checkbox"/> Dominance Test is >50% <input checked="" type="checkbox"/> Prevalence Index is ≤3.0 ¹ <input type="checkbox"/> Morphological Adaptations ¹ (Provide supporting data in Remarks or on a separate sheet) <input type="checkbox"/> Problematic Hydrophytic Vegetation ¹ (Explain)
2. _____				
3. _____				
4. _____				
5. _____				
6. _____				
7. _____				
8. _____				
	<u>0</u>	= Total Cover		
Woody Vine Stratum (Plot size: _____)				
1. _____				¹ Indicators of hydric soil and wetland hydrology must be present, unless disturbed or problematic.
2. _____				
	<u>0</u>	= Total Cover		
% Bare Ground in Herb Stratum <u>88</u> % Cover of Biotic Crust _____				
Remarks:				

Remarks:

SOIL

Sampling Point: 9

Profile Description: (Describe to the depth needed to document the indicator or confirm the absence of indicators.)

Depth (inches)	Matrix		Redox Features				Texture	Remarks
	Color (moist)	%	Color (moist)	%	Type ¹	Loc ²		
0-13+	7.5YR 4/4	100					Loamy sand	

¹Type: C=Concentration, D=Depletion, RM=Reduced Matrix, CS=Covered or Coated Sand Grains. ²Location: PL=Pore Lining, M=Matrix.

Hydric Soil Indicators: (Applicable to all LRRs, unless otherwise noted.)

- Histosol (A1)
- Histic Epipedon (A2)
- Black Histic (A3)
- Hydrogen Sulfide (A4)
- Stratified Layers (A5) **(LRR C)**
- 1 cm Muck (A9) **(LRR D)**
- Depleted Below Dark Surface (A11)
- Thick Dark Surface (A12)
- Sandy Mucky Mineral (S1)
- Sandy Gleyed Matrix (S4)

- Sandy Redox (S5)
- Stripped Matrix (S6)
- Loamy Mucky Mineral (F1)
- Loamy Gleyed Matrix (F2)
- Depleted Matrix (F3)
- Redox Dark Surface (F6)
- Depleted Dark Surface (F7)
- Redox Depressions (F8)
- Vernal Pools (F9)

Indicators for Problematic Hydric Soils³:

- 1 cm Muck (A9) **(LRR C)**
- 2 cm Muck (A10) **(LRR B)**
- Reduced Vertic (F18)
- Red Parent Material (TF2)
- Other (Explain in Remarks)

³Indicators of hydrophytic vegetation and wetland hydrology must be present, unless disturbed or problematic.

Restrictive Layer (if present):

Type: _____
 Depth (inches): _____

Hydric Soil Present? Yes _____ No

Remarks:

Dry until about 7", then moist.

HYDROLOGY

Wetland Hydrology Indicators:

Primary Indicators (minimum of one required; check all that apply)

- Surface Water (A1)
- High Water Table (A2)
- Saturation (A3)
- Water Marks (B1) **(Nonriverine)**
- Sediment Deposits (B2) **(Nonriverine)**
- Drift Deposits (B3) **(Nonriverine)**
- Surface Soil Cracks (B6)
- Inundation Visible on Aerial Imagery (B7)
- Water-Stained Leaves (B9)

- Salt Crust (B11)
- Biotic Crust (B12)
- Aquatic Invertebrates (B13)
- Hydrogen Sulfide Odor (C1)
- Oxidized Rhizospheres along Living Roots (C3)
- Presence of Reduced Iron (C4)
- Recent Iron Reduction in Tilled Soils (C6)
- Thin Muck Surface (C7)
- Other (Explain in Remarks)

Secondary Indicators (2 or more required)

- Water Marks (B1) **(Riverine)**
- Sediment Deposits (B2) **(Riverine)**
- Drift Deposits (B3) **(Riverine)**
- Drainage Patterns (B10)
- Dry-Season Water Table (C2)
- Crayfish Burrows (C8)
- Saturation Visible on Aerial Imagery (C9)
- Shallow Aquitard (D3)
- FAC-Neutral Test (D5)

Field Observations:

Surface Water Present? Yes _____ No Depth (inches): _____
 Water Table Present? Yes _____ No Depth (inches): _____
 Saturation Present? Yes _____ No Depth (inches): _____
 (includes capillary fringe)

Wetland Hydrology Present? Yes No _____

Describe Recorded Data (stream gauge, monitoring well, aerial photos, previous inspections), if available:

Remarks:

WETLAND DETERMINATION DATA FORM – Arid West Region

Project/Site: Vega SES 4 City/County: Holtville/ Imperial County Sampling Date: 11/5/2020
 Applicant/Owner: zGlobal, Inc. State: CA Sampling Point: 10
 Investigator(s): C. Congedo Section, Township, Range: S11, T17S, R16E
 Landform (hillslope, terrace, etc.): Depression Local relief (concave, convex, none): Concave Slope (%): 5
 Subregion (LRR): D Lat: 32.684182 Long: -115.307060 Datum: NAD83
 Soil Map Unit Name: Rositas fine sand, wet, 0 to 2 percent slopes NWI classification: N/A

Are climatic / hydrologic conditions on the site typical for this time of year? Yes No (If no, explain in Remarks.)
 Are Vegetation , Soil , or Hydrology significantly disturbed? Are "Normal Circumstances" present? Yes No
 Are Vegetation , Soil , or Hydrology naturally problematic? (If needed, explain any answers in Remarks.)

SUMMARY OF FINDINGS – Attach site map showing sampling point locations, transects, important features, etc.

Hydrophytic Vegetation Present? Yes <input checked="" type="checkbox"/> No <input type="checkbox"/> Hydric Soil Present? Yes <input type="checkbox"/> No <input checked="" type="checkbox"/> Wetland Hydrology Present? Yes <input checked="" type="checkbox"/> No <input type="checkbox"/>	Is the Sampled Area within a Wetland? Yes <input type="checkbox"/> No <input checked="" type="checkbox"/>
Remarks: Point taken on the outskirts of a slight depression in tamarisk thickets, ~500 feet downslope (south) of a hard-packed dirt road that runs parallel to the All-American Canal.	

VEGETATION – Use scientific names of plants.

Tree Stratum (Plot size: _____)	Absolute % Cover	Dominant Species?	Indicator Status		
1. <u>Tamarix sp.</u>	<u>3</u>		<u>FAC</u>	Dominance Test worksheet: Number of Dominant Species That Are OBL, FACW, or FAC: <u>1</u> (A) Total Number of Dominant Species Across All Strata: <u>1</u> (B) Percent of Dominant Species That Are OBL, FACW, or FAC: <u>100</u> (A/B)	
2. _____					
3. _____					
4. _____					
	<u>3</u>	= Total Cover			
Sapling/Shrub Stratum (Plot size: <u>20'</u>)					
1. <u>Pluchea sericea</u>	<u>8</u>	<u>x</u>	<u>FACW</u>	Prevalence Index worksheet: Total % Cover of: _____ Multiply by: _____ OBL species <u>0</u> x 1 = <u>0</u> FACW species <u>8</u> x 2 = <u>16</u> FAC species <u>3</u> x 3 = <u>9</u> FACU species <u>2</u> x 4 = <u>8</u> UPL species <u>0</u> x 5 = <u>0</u> Column Totals: <u>13</u> (A) <u>33</u> (B) Prevalence Index = B/A = <u>2.54</u>	
2. <u>Isocoma acradenia</u>	<u>2</u>		<u>FACU</u>		
3. _____					
4. _____					
5. _____					
	<u>10</u>	= Total Cover			
Herb Stratum (Plot size: _____)					
1. _____					
2. _____					
3. _____					
4. _____					
5. _____					
6. _____					
7. _____					
8. _____					
	<u>0</u>	= Total Cover			
Woody Vine Stratum (Plot size: _____)					
1. _____					
2. _____					
	<u>0</u>	= Total Cover			
% Bare Ground in Herb Stratum <u>87</u> % Cover of Biotic Crust _____					
Hydrophytic Vegetation Indicators: <input checked="" type="checkbox"/> Dominance Test is >50% <input checked="" type="checkbox"/> Prevalence Index is ≤3.0 ¹ <input type="checkbox"/> Morphological Adaptations ¹ (Provide supporting data in Remarks or on a separate sheet) <input type="checkbox"/> Problematic Hydrophytic Vegetation ¹ (Explain)					
¹ Indicators of hydric soil and wetland hydrology must be present, unless disturbed or problematic.					
Hydrophytic Vegetation Present? Yes <input checked="" type="checkbox"/> No <input type="checkbox"/>					

Remarks:

SOIL

Sampling Point: 10

Profile Description: (Describe to the depth needed to document the indicator or confirm the absence of indicators.)								
Depth (inches)	Matrix		Redox Features				Texture	Remarks
	Color (moist)	%	Color (moist)	%	Type ¹	Loc ²		
0-13+	7.5YR 4/4	100					Loamy sa ²	

¹Type: C=Concentration, D=Depletion, RM=Reduced Matrix, CS=Covered or Coated Sand Grains. ²Location: PL=Pore Lining, M=Matrix.

Hydric Soil Indicators: (Applicable to all LRRs, unless otherwise noted.)	Indicators for Problematic Hydric Soils³:
<input type="checkbox"/> Histosol (A1)	<input type="checkbox"/> 1 cm Muck (A9) (LRR C)
<input type="checkbox"/> Histic Epipedon (A2)	<input type="checkbox"/> 2 cm Muck (A10) (LRR B)
<input type="checkbox"/> Black Histic (A3)	<input type="checkbox"/> Reduced Vertic (F18)
<input type="checkbox"/> Hydrogen Sulfide (A4)	<input type="checkbox"/> Red Parent Material (TF2)
<input type="checkbox"/> Stratified Layers (A5) (LRR C)	<input type="checkbox"/> Other (Explain in Remarks)
<input type="checkbox"/> 1 cm Muck (A9) (LRR D)	
<input type="checkbox"/> Depleted Below Dark Surface (A11)	
<input type="checkbox"/> Thick Dark Surface (A12)	
<input type="checkbox"/> Sandy Mucky Mineral (S1)	
<input type="checkbox"/> Sandy Gleyed Matrix (S4)	
<input type="checkbox"/> Sandy Redox (S5)	
<input type="checkbox"/> Stripped Matrix (S6)	
<input type="checkbox"/> Loamy Mucky Mineral (F1)	
<input type="checkbox"/> Loamy Gleyed Matrix (F2)	
<input type="checkbox"/> Depleted Matrix (F3)	
<input type="checkbox"/> Redox Dark Surface (F6)	
<input type="checkbox"/> Depleted Dark Surface (F7)	
<input type="checkbox"/> Redox Depressions (F8)	
<input type="checkbox"/> Vernal Pools (F9)	

³Indicators of hydrophytic vegetation and wetland hydrology must be present, unless disturbed or problematic.

Restrictive Layer (if present):	Hydric Soil Present? Yes <input type="checkbox"/> No <input checked="" type="checkbox"/>
Type: _____	
Depth (inches): _____	

Remarks:
Moist 8" from surface.

HYDROLOGY

Wetland Hydrology Indicators:	
Primary Indicators (minimum of one required; check all that apply)	Secondary Indicators (2 or more required)
<input type="checkbox"/> Surface Water (A1)	<input type="checkbox"/> Salt Crust (B11)
<input type="checkbox"/> High Water Table (A2)	<input type="checkbox"/> Biotic Crust (B12)
<input type="checkbox"/> Saturation (A3)	<input type="checkbox"/> Aquatic Invertebrates (B13)
<input type="checkbox"/> Water Marks (B1) (Nonriverine)	<input type="checkbox"/> Hydrogen Sulfide Odor (C1)
<input checked="" type="checkbox"/> Sediment Deposits (B2) (Nonriverine)	<input type="checkbox"/> Oxidized Rhizospheres along Living Roots (C3)
<input type="checkbox"/> Drift Deposits (B3) (Nonriverine)	<input type="checkbox"/> Presence of Reduced Iron (C4)
<input type="checkbox"/> Surface Soil Cracks (B6)	<input type="checkbox"/> Recent Iron Reduction in Tilled Soils (C6)
<input type="checkbox"/> Inundation Visible on Aerial Imagery (B7)	<input type="checkbox"/> Thin Muck Surface (C7)
<input checked="" type="checkbox"/> Water-Stained Leaves (B9)	<input type="checkbox"/> Other (Explain in Remarks)
	<input type="checkbox"/> Water Marks (B1) (Riverine)
	<input type="checkbox"/> Sediment Deposits (B2) (Riverine)
	<input type="checkbox"/> Drift Deposits (B3) (Riverine)
	<input type="checkbox"/> Drainage Patterns (B10)
	<input type="checkbox"/> Dry-Season Water Table (C2)
	<input type="checkbox"/> Crayfish Burrows (C8)
	<input type="checkbox"/> Saturation Visible on Aerial Imagery (C9)
	<input type="checkbox"/> Shallow Aquitard (D3)
	<input type="checkbox"/> FAC-Neutral Test (D5)

Field Observations:	Wetland Hydrology Present? Yes <input checked="" type="checkbox"/> No <input type="checkbox"/>
Surface Water Present? Yes <input type="checkbox"/> No <input checked="" type="checkbox"/> Depth (inches): _____	
Water Table Present? Yes <input type="checkbox"/> No <input checked="" type="checkbox"/> Depth (inches): _____	
Saturation Present? (includes capillary fringe) Yes <input type="checkbox"/> No <input checked="" type="checkbox"/> Depth (inches): _____	

Describe Recorded Data (stream gauge, monitoring well, aerial photos, previous inspections), if available:

Remarks:

WETLAND DETERMINATION DATA FORM – Arid West Region

Project/Site: Vega SES 4 City/County: Holtville/ Imperial County Sampling Date: 11/5/2020
 Applicant/Owner: zGlobal, Inc. State: CA Sampling Point: 11
 Investigator(s): C. Congedo Section, Township, Range: S11, T17S, R16E
 Landform (hillslope, terrace, etc.): Depression Local relief (concave, convex, none): Concave Slope (%): 5
 Subregion (LRR): D Lat: 32.684568 Long: -115.307297 Datum: NAD83
 Soil Map Unit Name: Rositas fine sand, wet, 0 to 2 percent slopes NWI classification: N/A

Are climatic / hydrologic conditions on the site typical for this time of year? Yes No (If no, explain in Remarks.)
 Are Vegetation , Soil , or Hydrology significantly disturbed? Are "Normal Circumstances" present? Yes No
 Are Vegetation , Soil , or Hydrology naturally problematic? (If needed, explain any answers in Remarks.)

SUMMARY OF FINDINGS – Attach site map showing sampling point locations, transects, important features, etc.

Hydrophytic Vegetation Present? Yes <input checked="" type="checkbox"/> No <input type="checkbox"/> Hydric Soil Present? Yes <input checked="" type="checkbox"/> No <input type="checkbox"/> Wetland Hydrology Present? Yes <input checked="" type="checkbox"/> No <input type="checkbox"/>	Is the Sampled Area within a Wetland? Yes <input checked="" type="checkbox"/> No <input type="checkbox"/>
Remarks: Point taken within a slight depression in tamarisk thickets, ~300 feet downslope (south) of a hard-packed dirt road that runs parallel to the All-American Canal.	

VEGETATION – Use scientific names of plants.

Tree Stratum (Plot size: <u>20'</u>)	Absolute % Cover	Dominant Species?	Indicator Status	
1. <u>Tamarix sp.</u>	<u>2</u>		<u>FAC</u>	Dominance Test worksheet: Number of Dominant Species That Are OBL, FACW, or FAC: <u>1</u> (A) Total Number of Dominant Species Across All Strata: <u>1</u> (B) Percent of Dominant Species That Are OBL, FACW, or FAC: <u>100</u> (A/B)
2. _____				
3. _____				
4. _____				
	<u>2</u>	= Total Cover		
Sapling/Shrub Stratum (Plot size: <u>20'</u>)				
1. <u>Pluchea sericea</u>	<u>15</u>	<u>x</u>	<u>FACW</u>	Prevalence Index worksheet: Total % Cover of: _____ Multiply by: _____ OBL species <u>0</u> x 1 = <u>0</u> FACW species <u>15</u> x 2 = <u>30</u> FAC species <u>7</u> x 3 = <u>21</u> FACU species <u>0</u> x 4 = <u>0</u> UPL species <u>0</u> x 5 = <u>0</u> Column Totals: <u>22</u> (A) <u>51</u> (B) Prevalence Index = B/A = <u>2.32</u>
2. <u>Tamarix sp.</u>	<u>5</u>		<u>FAC</u>	
3. _____				
4. _____				
5. _____				
	<u>20</u>	= Total Cover		
Herb Stratum (Plot size: _____)				
1. _____				Hydrophytic Vegetation Indicators: <input checked="" type="checkbox"/> Dominance Test is >50% <input checked="" type="checkbox"/> Prevalence Index is ≤3.0 ¹ <input type="checkbox"/> Morphological Adaptations ¹ (Provide supporting data in Remarks or on a separate sheet) <input type="checkbox"/> Problematic Hydrophytic Vegetation ¹ (Explain)
2. _____				
3. _____				
4. _____				
5. _____				
6. _____				
7. _____				
8. _____				
	<u>0</u>	= Total Cover		
Woody Vine Stratum (Plot size: _____)				
1. _____				¹ Indicators of hydric soil and wetland hydrology must be present, unless disturbed or problematic.
2. _____				
	<u>0</u>	= Total Cover		
% Bare Ground in Herb Stratum <u>78</u> % Cover of Biotic Crust _____		Hydrophytic Vegetation Present? Yes <input checked="" type="checkbox"/> No <input type="checkbox"/>		

Remarks:

SOIL

Sampling Point: 11

Profile Description: (Describe to the depth needed to document the indicator or confirm the absence of indicators.)

Depth (inches)	Matrix		Redox Features				Texture	Remarks
	Color (moist)	%	Color (moist)	%	Type ¹	Loc ²		
0-1	Gley 1, 2.5/N	65	7.5YR 4/4	35			Loamy sand	
1-4	7.5YR 4/4	100					Loamy sand	
4-12	7.5YR 4/4	94	5Y 4/6	6	C	PL	Loam	

¹Type: C=Concentration, D=Depletion, RM=Reduced Matrix, CS=Covered or Coated Sand Grains. ²Location: PL=Pore Lining, M=Matrix.

Hydric Soil Indicators: (Applicable to all LRRs, unless otherwise noted.)

- Histosol (A1)
- Histic Epipedon (A2)
- Black Histic (A3)
- Hydrogen Sulfide (A4)
- Stratified Layers (A5) **(LRR C)**
- 1 cm Muck (A9) **(LRR D)**
- Depleted Below Dark Surface (A11)
- Thick Dark Surface (A12)
- Sandy Mucky Mineral (S1)
- Sandy Gleyed Matrix (S4)
- Sandy Redox (S5)
- Stripped Matrix (S6)
- Loamy Mucky Mineral (F1)
- Loamy Gleyed Matrix (F2)
- Depleted Matrix (F3)
- Redox Dark Surface (F6)
- Depleted Dark Surface (F7)
- Redox Depressions (F8)
- Vernal Pools (F9)

Indicators for Problematic Hydric Soils³:

- 1 cm Muck (A9) **(LRR C)**
- 2 cm Muck (A10) **(LRR B)**
- Reduced Vertic (F18)
- Red Parent Material (TF2)
- Other (Explain in Remarks)

³Indicators of hydrophytic vegetation and wetland hydrology must be present, unless disturbed or problematic.

Restrictive Layer (if present):

Type: _____
Depth (inches): _____

Hydric Soil Present? Yes No

Remarks:

HYDROLOGY

Wetland Hydrology Indicators:

Primary Indicators (minimum of one required; check all that apply)

- Surface Water (A1)
- High Water Table (A2)
- Saturation (A3)
- Water Marks (B1) **(Nonriverine)**
- Sediment Deposits (B2) **(Nonriverine)**
- Drift Deposits (B3) **(Nonriverine)**
- Surface Soil Cracks (B6)
- Inundation Visible on Aerial Imagery (B7)
- Water-Stained Leaves (B9)

- Salt Crust (B11)
- Biotic Crust (B12)
- Aquatic Invertebrates (B13)
- Hydrogen Sulfide Odor (C1)
- Oxidized Rhizospheres along Living Roots (C3)
- Presence of Reduced Iron (C4)
- Recent Iron Reduction in Tilled Soils (C6)
- Thin Muck Surface (C7)
- Other (Explain in Remarks)

Secondary Indicators (2 or more required)

- Water Marks (B1) **(Riverine)**
- Sediment Deposits (B2) **(Riverine)**
- Drift Deposits (B3) **(Riverine)**
- Drainage Patterns (B10)
- Dry-Season Water Table (C2)
- Crayfish Burrows (C8)
- Saturation Visible on Aerial Imagery (C9)
- Shallow Aquitard (D3)
- FAC-Neutral Test (D5)

Field Observations:

Surface Water Present? Yes No Depth (inches): _____
 Water Table Present? Yes No Depth (inches): _____
 Saturation Present? (includes capillary fringe) Yes No Depth (inches): _____

Wetland Hydrology Present? Yes No

Describe Recorded Data (stream gauge, monitoring well, aerial photos, previous inspections), if available:

Remarks:

Moist soils from 3" down.

WETLAND DETERMINATION DATA FORM – Arid West Region

Project/Site: Vega SES 4 City/County: Holtville/ Imperial County Sampling Date: 11/5/2020
 Applicant/Owner: zGlobal, Inc. State: CA Sampling Point: 12
 Investigator(s): C. Congedo Section, Township, Range: S11, T17S, R16E
 Landform (hillslope, terrace, etc.): Depression Local relief (concave, convex, none): Concave Slope (%): 3
 Subregion (LRR): D Lat: 32.683847 Long: -115.309409 Datum: NAD83
 Soil Map Unit Name: Rositas fine sand, wet, 0 to 2 percent slopes NWI classification: N/A

Are climatic / hydrologic conditions on the site typical for this time of year? Yes No (If no, explain in Remarks.)
 Are Vegetation , Soil , or Hydrology significantly disturbed? Are "Normal Circumstances" present? Yes No
 Are Vegetation , Soil , or Hydrology naturally problematic? (If needed, explain any answers in Remarks.)

SUMMARY OF FINDINGS – Attach site map showing sampling point locations, transects, important features, etc.

Hydrophytic Vegetation Present? Yes <input checked="" type="checkbox"/> No <input type="checkbox"/> Hydric Soil Present? Yes <input checked="" type="checkbox"/> No <input type="checkbox"/> Wetland Hydrology Present? Yes <input checked="" type="checkbox"/> No <input type="checkbox"/>	Is the Sampled Area within a Wetland? Yes <input checked="" type="checkbox"/> No <input type="checkbox"/>
Remarks: Point taken within a slight depression in tamarisk thickets, ~300 feet downslope (south) of a hard-packed dirt road that runs parallel to the All-American Canal.	

VEGETATION – Use scientific names of plants.

Tree Stratum (Plot size: <u>20'</u>)	Absolute % Cover	Dominant Species?	Indicator Status	
1. <u>Tamarix sp.</u>	<u>5</u>		<u>FAC</u>	Dominance Test worksheet: Number of Dominant Species That Are OBL, FACW, or FAC: <u>1</u> (A) Total Number of Dominant Species Across All Strata: <u>1</u> (B) Percent of Dominant Species That Are OBL, FACW, or FAC: <u>100</u> (A/B)
2. _____				
3. _____				
4. _____				
<u>5</u> = Total Cover				
Sapling/Shrub Stratum (Plot size: _____)				
1. <u>Tamarix sp.</u>	<u>2</u>		<u>FAC</u>	Prevalence Index worksheet: Total % Cover of: _____ Multiply by: _____ OBL species <u>0</u> x 1 = <u>0</u> FACW species <u>15</u> x 2 = <u>30</u> FAC species <u>7</u> x 3 = <u>21</u> FACU species <u>0</u> x 4 = <u>0</u> UPL species <u>0</u> x 5 = <u>0</u> Column Totals: <u>22</u> (A) <u>51</u> (B) Prevalence Index = B/A = <u>2.32</u>
2. <u>Pluchea sericea</u>	<u>15</u>	<u>x</u>	<u>FACW</u>	
3. _____				
4. _____				
5. _____				
<u>17</u> = Total Cover				
Herb Stratum (Plot size: _____)				
1. _____				Hydrophytic Vegetation Indicators: <input checked="" type="checkbox"/> Dominance Test is >50% <input checked="" type="checkbox"/> Prevalence Index is ≤3.0 ¹ <input type="checkbox"/> Morphological Adaptations ¹ (Provide supporting data in Remarks or on a separate sheet) <input type="checkbox"/> Problematic Hydrophytic Vegetation ¹ (Explain) ¹ Indicators of hydric soil and wetland hydrology must be present, unless disturbed or problematic.
2. _____				
3. _____				
4. _____				
5. _____				
6. _____				
7. _____				
8. _____				
<u>0</u> = Total Cover				
Woody Vine Stratum (Plot size: _____)				
1. _____				Hydrophytic Vegetation Present? Yes <input checked="" type="checkbox"/> No <input type="checkbox"/>
2. _____				
<u>0</u> = Total Cover				
% Bare Ground in Herb Stratum <u>78</u> % Cover of Biotic Crust _____				

Remarks:

SOIL

Sampling Point: 12

Profile Description: (Describe to the depth needed to document the indicator or confirm the absence of indicators.)

Depth (inches)	Matrix		Redox Features				Texture	Remarks
	Color (moist)	%	Color (moist)	%	Type ¹	Loc ²		
0-1	Gley 1, 5/N	70					Loamy sand	
0-1	7.5YR 4/4	30					Loamy sand	
1-3	7.5YR 4/4	97	Gley 1, 5/N	3	C	M	Loamy sand	
3-12	7.5YR 4/4	95	7.5YR 5/8	5	C	M	Loamy sand	

¹Type: C=Concentration, D=Depletion, RM=Reduced Matrix, CS=Covered or Coated Sand Grains. ²Location: PL=Pore Lining, M=Matrix.

Hydric Soil Indicators: (Applicable to all LRRs, unless otherwise noted.) <input type="checkbox"/> Histosol (A1) <input type="checkbox"/> Histic Epipedon (A2) <input type="checkbox"/> Black Histic (A3) <input type="checkbox"/> Hydrogen Sulfide (A4) <input type="checkbox"/> Stratified Layers (A5) (LRR C) <input type="checkbox"/> 1 cm Muck (A9) (LRR D) <input type="checkbox"/> Depleted Below Dark Surface (A11) <input type="checkbox"/> Thick Dark Surface (A12) <input type="checkbox"/> Sandy Mucky Mineral (S1) <input checked="" type="checkbox"/> Sandy Gleyed Matrix (S4)	<input type="checkbox"/> Sandy Redox (S5) <input type="checkbox"/> Stripped Matrix (S6) <input type="checkbox"/> Loamy Mucky Mineral (F1) <input type="checkbox"/> Loamy Gleyed Matrix (F2) <input type="checkbox"/> Depleted Matrix (F3) <input type="checkbox"/> Redox Dark Surface (F6) <input type="checkbox"/> Depleted Dark Surface (F7) <input type="checkbox"/> Redox Depressions (F8) <input type="checkbox"/> Vernal Pools (F9)	Indicators for Problematic Hydric Soils³: <input type="checkbox"/> 1 cm Muck (A9) (LRR C) <input type="checkbox"/> 2 cm Muck (A10) (LRR B) <input type="checkbox"/> Reduced Vertic (F18) <input type="checkbox"/> Red Parent Material (TF2) <input type="checkbox"/> Other (Explain in Remarks)
-----------------------------------------------------------------------------------------------------------------------------------------------------------------------------------------------------------------------------------------------------------------------------------------------------------------------------------------------------------------------------------------------------------------------------------------------------------------------------------------------------------------------------------------------------------------------------------------------------------------------------------------------------	-------------------------------------------------------------------------------------------------------------------------------------------------------------------------------------------------------------------------------------------------------------------------------------------------------------------------------------------------------------------------------------------------------------------------------------------------------------------	----------------------------------------------------------------------------------------------------------------------------------------------------------------------------------------------------------------------------------------------------------------------------------------------------------------------------------------------------

³Indicators of hydrophytic vegetation and wetland hydrology must be present, unless disturbed or problematic.

Restrictive Layer (if present):
 Type: _____
 Depth (inches): _____

Hydric Soil Present? Yes No

Remarks:

HYDROLOGY

Wetland Hydrology Indicators:

Primary Indicators (minimum of one required; check all that apply)	Secondary Indicators (2 or more required)
<input type="checkbox"/> Surface Water (A1) <input type="checkbox"/> High Water Table (A2) <input type="checkbox"/> Saturation (A3) <input type="checkbox"/> Water Marks (B1) (Nonriverine) <input checked="" type="checkbox"/> Sediment Deposits (B2) (Nonriverine) <input type="checkbox"/> Drift Deposits (B3) (Nonriverine) <input type="checkbox"/> Surface Soil Cracks (B6) <input type="checkbox"/> Inundation Visible on Aerial Imagery (B7) <input checked="" type="checkbox"/> Water-Stained Leaves (B9)	<input type="checkbox"/> Salt Crust (B11) <input type="checkbox"/> Biotic Crust (B12) <input type="checkbox"/> Aquatic Invertebrates (B13) <input type="checkbox"/> Hydrogen Sulfide Odor (C1) <input type="checkbox"/> Oxidized Rhizospheres along Living Roots (C3) <input type="checkbox"/> Presence of Reduced Iron (C4) <input type="checkbox"/> Recent Iron Reduction in Tilled Soils (C6) <input type="checkbox"/> Thin Muck Surface (C7) <input type="checkbox"/> Other (Explain in Remarks)

<input type="checkbox"/> Water Marks (B1) (Riverine) <input type="checkbox"/> Sediment Deposits (B2) (Riverine) <input type="checkbox"/> Drift Deposits (B3) (Riverine) <input type="checkbox"/> Drainage Patterns (B10) <input type="checkbox"/> Dry-Season Water Table (C2) <input type="checkbox"/> Crayfish Burrows (C8) <input type="checkbox"/> Saturation Visible on Aerial Imagery (C9) <input type="checkbox"/> Shallow Aquitard (D3) <input checked="" type="checkbox"/> FAC-Neutral Test (D5)

Field Observations:

Surface Water Present? Yes _____ No <input checked="" type="checkbox"/> Depth (inches): _____ Water Table Present? Yes _____ No <input checked="" type="checkbox"/> Depth (inches): _____ Saturation Present? (includes capillary fringe) Yes _____ No <input checked="" type="checkbox"/> Depth (inches): _____	Wetland Hydrology Present? Yes <input checked="" type="checkbox"/> No <input type="checkbox"/>
------------------------------------------------------------------------------------------------------------------------------------------------------------------------------------------------------------------------------------------------------------------------------------------------------------------------	-------------------------------------------------------------------------------------------------------

Describe Recorded Data (stream gauge, monitoring well, aerial photos, previous inspections), if available:

Remarks:
 Moist at 7" deep.

WETLAND DETERMINATION DATA FORM – Arid West Region

Project/Site: Vega SES 4 City/County: Holtville/ Imperial County Sampling Date: 11/5/2020
 Applicant/Owner: zGlobal, Inc. State: CA Sampling Point: 13
 Investigator(s): C. Congedo Section, Township, Range: S10, T17S, R16E
 Landform (hillslope, terrace, etc.): Depression Local relief (concave, convex, none): Concave Slope (%): 3
 Subregion (LRR): D Lat: 32.683831 Long: -115.310470 Datum: NAD83
 Soil Map Unit Name: Rositas fine sand, wet, 0 to 2 percent slopes NWI classification: N/A

Are climatic / hydrologic conditions on the site typical for this time of year? Yes No (If no, explain in Remarks.)
 Are Vegetation , Soil , or Hydrology significantly disturbed? Are "Normal Circumstances" present? Yes No
 Are Vegetation , Soil , or Hydrology naturally problematic? (If needed, explain any answers in Remarks.)

SUMMARY OF FINDINGS – Attach site map showing sampling point locations, transects, important features, etc.

Hydrophytic Vegetation Present? Yes <input checked="" type="checkbox"/> No <input type="checkbox"/> Hydric Soil Present? Yes <input type="checkbox"/> No <input checked="" type="checkbox"/> Wetland Hydrology Present? Yes <input checked="" type="checkbox"/> No <input type="checkbox"/>	Is the Sampled Area within a Wetland? Yes <input type="checkbox"/> No <input checked="" type="checkbox"/>
Remarks: Point taken on the outskirts of a slight depression in tamarisk thickets, ~200 feet downslope (south) of a hard-packed dirt road that runs parallel to the All-American Canal.	

VEGETATION – Use scientific names of plants.

Tree Stratum (Plot size: <u>15'</u>)	Absolute % Cover	Dominant Species?	Indicator Status	
1. <u>Tamarix sp.</u>	<u>2</u>		<u>FAC</u>	Dominance Test worksheet: Number of Dominant Species That Are OBL, FACW, or FAC: <u>1</u> (A) Total Number of Dominant Species Across All Strata: <u>1</u> (B) Percent of Dominant Species That Are OBL, FACW, or FAC: <u>100</u> (A/B)
2. _____				
3. _____				
4. _____				
	<u>2</u>	= Total Cover		
Sapling/Shrub Stratum (Plot size: <u>15'</u>)				
1. <u>Isocoma acradenia</u>	<u>4</u>		<u>FACU</u>	Prevalence Index worksheet: Total % Cover of: _____ Multiply by: _____ OBL species <u>0</u> x 1 = <u>0</u> FACW species <u>8</u> x 2 = <u>16</u> FAC species <u>2</u> x 3 = <u>6</u> FACU species <u>4</u> x 4 = <u>16</u> UPL species <u>0</u> x 5 = <u>0</u> Column Totals: <u>14</u> (A) <u>38</u> (B) Prevalence Index = B/A = <u>2.71</u>
2. <u>Pluchea sericea</u>	<u>8</u>	<u>x</u>	<u>FACW</u>	
3. _____				
4. _____				
5. _____				
	<u>12</u>	= Total Cover		
Herb Stratum (Plot size: _____)				
1. _____				Hydrophytic Vegetation Indicators: <input checked="" type="checkbox"/> Dominance Test is >50% <input checked="" type="checkbox"/> Prevalence Index is ≤3.0 ¹ <input type="checkbox"/> Morphological Adaptations ¹ (Provide supporting data in Remarks or on a separate sheet) <input type="checkbox"/> Problematic Hydrophytic Vegetation ¹ (Explain)
2. _____				
3. _____				
4. _____				
5. _____				
6. _____				
7. _____				
8. _____				
	<u>0</u>	= Total Cover		
Woody Vine Stratum (Plot size: _____)				
1. _____				¹ Indicators of hydric soil and wetland hydrology must be present, unless disturbed or problematic.
2. _____				
	<u>0</u>	= Total Cover		
% Bare Ground in Herb Stratum <u>86</u> % Cover of Biotic Crust _____				Hydrophytic Vegetation Present? Yes <input checked="" type="checkbox"/> No <input type="checkbox"/>

Remarks:

SOIL

Profile Description: (Describe to the depth needed to document the indicator or confirm the absence of indicators.)

Depth (inches)	Matrix		Redox Features				Texture	Remarks
	Color (moist)	%	Color (moist)	%	Type ¹	Loc ²		
0-7	7.5YR 4/4	100					Loamy sand	
7-14	7.5YR 4/4	97	7.5YR 5/8	3	C	PL	Loamy sand	

¹Type: C=Concentration, D=Depletion, RM=Reduced Matrix, CS=Covered or Coated Sand Grains. ²Location: PL=Pore Lining, M=Matrix.

Hydric Soil Indicators: (Applicable to all LRRs, unless otherwise noted.)

- Histosol (A1)
- Histic Epipedon (A2)
- Black Histic (A3)
- Hydrogen Sulfide (A4)
- Stratified Layers (A5) **(LRR C)**
- 1 cm Muck (A9) **(LRR D)**
- Depleted Below Dark Surface (A11)
- Thick Dark Surface (A12)
- Sandy Mucky Mineral (S1)
- Sandy Gleyed Matrix (S4)
- Sandy Redox (S5)
- Stripped Matrix (S6)
- Loamy Mucky Mineral (F1)
- Loamy Gleyed Matrix (F2)
- Depleted Matrix (F3)
- Redox Dark Surface (F6)
- Depleted Dark Surface (F7)
- Redox Depressions (F8)
- Vernal Pools (F9)

Indicators for Problematic Hydric Soils³:

- 1 cm Muck (A9) **(LRR C)**
- 2 cm Muck (A10) **(LRR B)**
- Reduced Vertic (F18)
- Red Parent Material (TF2)
- Other (Explain in Remarks)

³Indicators of hydrophytic vegetation and wetland hydrology must be present, unless disturbed or problematic.

Restrictive Layer (if present):

Type: _____
Depth (inches): _____

Hydric Soil Present? Yes _____ No

Remarks:

HYDROLOGY

Wetland Hydrology Indicators:

Primary Indicators (minimum of one required; check all that apply)

- Surface Water (A1)
- High Water Table (A2)
- Saturation (A3)
- Water Marks (B1) **(Nonriverine)**
- Sediment Deposits (B2) **(Nonriverine)**
- Drift Deposits (B3) **(Nonriverine)**
- Surface Soil Cracks (B6)
- Inundation Visible on Aerial Imagery (B7)
- Water-Stained Leaves (B9)

Secondary Indicators (2 or more required)

- Salt Crust (B11)
- Biotic Crust (B12)
- Aquatic Invertebrates (B13)
- Hydrogen Sulfide Odor (C1)
- Oxidized Rhizospheres along Living Roots (C3)
- Presence of Reduced Iron (C4)
- Recent Iron Reduction in Tilled Soils (C6)
- Thin Muck Surface (C7)
- Other (Explain in Remarks)
- Water Marks (B1) **(Riverine)**
- Sediment Deposits (B2) **(Riverine)**
- Drift Deposits (B3) **(Riverine)**
- Drainage Patterns (B10)
- Dry-Season Water Table (C2)
- Crayfish Burrows (C8)
- Saturation Visible on Aerial Imagery (C9)
- Shallow Aquitard (D3)
- FAC-Neutral Test (D5)

Field Observations:

Surface Water Present? Yes _____ No Depth (inches): _____
 Water Table Present? Yes _____ No Depth (inches): _____
 Saturation Present? (includes capillary fringe) Yes _____ No Depth (inches): _____

Wetland Hydrology Present? Yes No _____

Describe Recorded Data (stream gauge, monitoring well, aerial photos, previous inspections), if available:

Remarks:

Soil moist at 7" depth.

WETLAND DETERMINATION DATA FORM – Arid West Region

Project/Site: Vega SES 4 City/County: Holtville/ Imperial County Sampling Date: 11/5/2020
 Applicant/Owner: zGlobal, Inc. State: CA Sampling Point: 14
 Investigator(s): C. Congedo Section, Township, Range: S10, T17S, R16E
 Landform (hillslope, terrace, etc.): Depression Local relief (concave, convex, none): Concave Slope (%): 3
 Subregion (LRR): D Lat: 32.683739 Long: -115.311776 Datum: NAD83
 Soil Map Unit Name: Rositas fine sand, wet, 0 to 2 percent slopes NWI classification: N/A

Are climatic / hydrologic conditions on the site typical for this time of year? Yes No (If no, explain in Remarks.)
 Are Vegetation , Soil , or Hydrology significantly disturbed? Are "Normal Circumstances" present? Yes No
 Are Vegetation , Soil , or Hydrology naturally problematic? (If needed, explain any answers in Remarks.)

SUMMARY OF FINDINGS – Attach site map showing sampling point locations, transects, important features, etc.

Hydrophytic Vegetation Present? Yes <input checked="" type="checkbox"/> No <input type="checkbox"/> Hydric Soil Present? Yes <input checked="" type="checkbox"/> No <input type="checkbox"/> Wetland Hydrology Present? Yes <input checked="" type="checkbox"/> No <input type="checkbox"/>	Is the Sampled Area within a Wetland? Yes <input checked="" type="checkbox"/> No <input type="checkbox"/>
Remarks: Point taken within arrow weed thickets, ~90 feet downslope (south) of a hard-packed dirt road that runs parallel to the All-American Canal.	

VEGETATION – Use scientific names of plants.

Tree Stratum (Plot size: <u>20'</u>)	Absolute % Cover	Dominant Species?	Indicator Status	
1. <u>Prosopis pubescens</u>	<u>2</u>		<u>FAC</u>	Dominance Test worksheet: Number of Dominant Species That Are OBL, FACW, or FAC: <u>1</u> (A) Total Number of Dominant Species Across All Strata: <u>1</u> (B) Percent of Dominant Species That Are OBL, FACW, or FAC: <u>100</u> (A/B)
2. <u>Tamarix sp.</u>	<u>2</u>		<u>FAC</u>	
3. _____				
4. _____				
<u>4</u> = Total Cover				Prevalence Index worksheet: Total % Cover of: _____ Multiply by: _____ OBL species <u>0</u> x 1 = <u>0</u> FACW species <u>15</u> x 2 = <u>30</u> FAC species <u>4</u> x 3 = <u>12</u> FACU species <u>0</u> x 4 = <u>0</u> UPL species <u>0</u> x 5 = <u>0</u> Column Totals: <u>19</u> (A) <u>42</u> (B) Prevalence Index = B/A = <u>2.21</u>
<u>15</u> = Total Cover				
Sapling/Shrub Stratum (Plot size: <u>20'</u>)				
1. <u>Pluchea sericea</u>	<u>15</u>	<u>x</u>	<u>FACW</u>	
2. _____				
3. _____				
4. _____				
5. _____				
<u>15</u> = Total Cover				
Herb Stratum (Plot size: _____)				
1. _____				
2. _____				
3. _____				
4. _____				
5. _____				
6. _____				
7. _____				
8. _____				
<u>0</u> = Total Cover				
Woody Vine Stratum (Plot size: _____)				
1. _____				
2. _____				
<u>0</u> = Total Cover				
% Bare Ground in Herb Stratum <u>81</u>		% Cover of Biotic Crust _____		
Hydrophytic Vegetation Indicators: <input checked="" type="checkbox"/> Dominance Test is >50% <input checked="" type="checkbox"/> Prevalence Index is ≤3.0 ¹ <input type="checkbox"/> Morphological Adaptations ¹ (Provide supporting data in Remarks or on a separate sheet) <input type="checkbox"/> Problematic Hydrophytic Vegetation ¹ (Explain)				
¹ Indicators of hydric soil and wetland hydrology must be present, unless disturbed or problematic.				
Hydrophytic Vegetation Present? Yes <input checked="" type="checkbox"/> No <input type="checkbox"/>				
Remarks:				

SOIL

Sampling Point: 14

Profile Description: (Describe to the depth needed to document the indicator or confirm the absence of indicators.)								
Depth (inches)	Matrix		Redox Features				Texture	Remarks
	Color (moist)	%	Color (moist)	%	Type ¹	Loc ²		
0-6	7.5YR 4/4	95	5YR 4/6	5	C	PL	loam	
6-14+	10YR 5/3	92	5YR 4/6	8	C	M, PL	Loamy sand	

¹Type: C=Concentration, D=Depletion, RM=Reduced Matrix, CS=Covered or Coated Sand Grains. ²Location: PL=Pore Lining, M=Matrix.

Hydric Soil Indicators: (Applicable to all LRRs, unless otherwise noted.)

- Histic Epipedon (A2)
- Black Histic (A3)
- Hydrogen Sulfide (A4)
- Stratified Layers (A5) (LRR C)
- 1 cm Muck (A9) (LRR D)
- Depleted Below Dark Surface (A11)
- Thick Dark Surface (A12)
- Sandy Mucky Mineral (S1)
- Sandy Gleyed Matrix (S4)
- Sandy Redox (S5)
- Stripped Matrix (S6)
- Loamy Mucky Mineral (F1)
- Loamy Gleyed Matrix (F2)
- Depleted Matrix (F3)
- Redox Dark Surface (F6)
- Depleted Dark Surface (F7)
- Redox Depressions (F8)
- Vernal Pools (F9)

Indicators for Problematic Hydric Soils³:

- 1 cm Muck (A9) (LRR C)
- 2 cm Muck (A10) (LRR B)
- Reduced Vertic (F18)
- Red Parent Material (TF2)
- Other (Explain in Remarks)

³Indicators of hydrophytic vegetation and wetland hydrology must be present, unless disturbed or problematic.

Restrictive Layer (if present):

Type: _____
Depth (inches): _____

Hydric Soil Present? Yes No

Remarks:

Soil moist throughout; organic material in first 4 inches.

HYDROLOGY

Wetland Hydrology Indicators:

Primary Indicators (minimum of one required; check all that apply)

- Surface Water (A1)
- High Water Table (A2)
- Saturation (A3)
- Water Marks (B1) (Nonriverine)
- Sediment Deposits (B2) (Nonriverine)
- Drift Deposits (B3) (Nonriverine)
- Surface Soil Cracks (B6)
- Inundation Visible on Aerial Imagery (B7)
- Water-Stained Leaves (B9)

- Salt Crust (B11)
- Biotic Crust (B12)
- Aquatic Invertebrates (B13)
- Hydrogen Sulfide Odor (C1)
- Oxidized Rhizospheres along Living Roots (C3)
- Presence of Reduced Iron (C4)
- Recent Iron Reduction in Tilled Soils (C6)
- Thin Muck Surface (C7)
- Other (Explain in Remarks)

Secondary Indicators (2 or more required)

- Water Marks (B1) (Riverine)
- Sediment Deposits (B2) (Riverine)
- Drift Deposits (B3) (Riverine)
- Drainage Patterns (B10)
- Dry-Season Water Table (C2)
- Crayfish Burrows (C8)
- Saturation Visible on Aerial Imagery (C9)
- Shallow Aquitard (D3)
- FAC-Neutral Test (D5)

Field Observations:

Surface Water Present? Yes No Depth (inches): _____
 Water Table Present? Yes No Depth (inches): _____
 Saturation Present? (includes capillary fringe) Yes No Depth (inches): _____

Wetland Hydrology Present? Yes No

Describe Recorded Data (stream gauge, monitoring well, aerial photos, previous inspections), if available:

Remarks:

Soil moist.

WETLAND DETERMINATION DATA FORM – Arid West Region

Project/Site: Vega SES 4 City/County: Holtville/ Imperial County Sampling Date: 11/12/2020
 Applicant/Owner: zGlobal, Inc. State: CA Sampling Point: 400
 Investigator(s): C. Congedo, C. Garcia, C. Torres Section, Township, Range: S11, T17S, R16E
 Landform (hillslope, terrace, etc.): Toeslope Local relief (concave, convex, none): Concave Slope (%): 5
 Subregion (LRR): D Lat: 32.690557 Long: -115.294997 Datum: NAD83
 Soil Map Unit Name: Rositas fine sand, wet, 0 to 2 percent slopes NWI classification: N/A

Are climatic / hydrologic conditions on the site typical for this time of year? Yes No (If no, explain in Remarks.)
 Are Vegetation , Soil , or Hydrology significantly disturbed? Are "Normal Circumstances" present? Yes No
 Are Vegetation , Soil , or Hydrology naturally problematic? (If needed, explain any answers in Remarks.)

SUMMARY OF FINDINGS – Attach site map showing sampling point locations, transects, important features, etc.

Hydrophytic Vegetation Present? Yes <input checked="" type="checkbox"/> No <input type="checkbox"/> Hydric Soil Present? Yes <input type="checkbox"/> No <input checked="" type="checkbox"/> Wetland Hydrology Present? Yes <input checked="" type="checkbox"/> No <input type="checkbox"/>	Is the Sampled Area within a Wetland? Yes <input checked="" type="checkbox"/> No <input type="checkbox"/>
Remarks: Point taken within a previously disturbed riparian area, downslope (south) of a hard-packed dirt road that runs parallel to the All-American Canal. An adjacent graded road exists approximately 10 feet south of sample point.	

VEGETATION – Use scientific names of plants.

Tree Stratum (Plot size: <u>15'</u>)	Absolute % Cover	Dominant Species?	Indicator Status	
1. <u>Tamarix sp.</u>	<u>20</u>	<u>x</u>	<u>FAC</u>	Dominance Test worksheet: Number of Dominant Species That Are OBL, FACW, or FAC: <u>2</u> (A) Total Number of Dominant Species Across All Strata: <u>2</u> (B) Percent of Dominant Species That Are OBL, FACW, or FAC: <u>100</u> (A/B)
2. _____	_____	_____	_____	
3. _____	_____	_____	_____	
4. _____	_____	_____	_____	
<u>20</u> = Total Cover				
Sapling/Shrub Stratum (Plot size: <u>15'</u>)				
1. <u>Typha sp.</u>	<u>10</u>	<u>x</u>	<u>OBL</u>	Prevalence Index worksheet: Total % Cover of: _____ Multiply by: _____ OBL species <u>10</u> x 1 = <u>10</u> FACW species <u>5</u> x 2 = <u>10</u> FAC species <u>20</u> x 3 = <u>60</u> FACU species <u>0</u> x 4 = <u>0</u> UPL species <u>0</u> x 5 = <u>0</u> Column Totals: <u>35</u> (A) <u>80</u> (B) Prevalence Index = B/A = <u>2.29</u>
2. <u>Pluchea sericea</u>	<u>5</u>	_____	<u>FACW</u>	
3. _____	_____	_____	_____	
4. _____	_____	_____	_____	
5. _____	_____	_____	_____	
<u>15</u> = Total Cover				
Herb Stratum (Plot size: _____)				
1. _____	_____	_____	_____	Hydrophytic Vegetation Indicators: <input checked="" type="checkbox"/> Dominance Test is >50% <input checked="" type="checkbox"/> Prevalence Index is ≤3.0 ¹ <input type="checkbox"/> Morphological Adaptations ¹ (Provide supporting data in Remarks or on a separate sheet) <input type="checkbox"/> Problematic Hydrophytic Vegetation ¹ (Explain) ¹ Indicators of hydric soil and wetland hydrology must be present, unless disturbed or problematic.
2. _____	_____	_____	_____	
3. _____	_____	_____	_____	
4. _____	_____	_____	_____	
5. _____	_____	_____	_____	
6. _____	_____	_____	_____	
7. _____	_____	_____	_____	
8. _____	_____	_____	_____	
<u>0</u> = Total Cover				
Woody Vine Stratum (Plot size: _____)				
1. _____	_____	_____	_____	Hydrophytic Vegetation Present? Yes <input checked="" type="checkbox"/> No <input type="checkbox"/>
2. _____	_____	_____	_____	
<u>0</u> = Total Cover				
% Bare Ground in Herb Stratum <u>65</u> % Cover of Biotic Crust _____				

Remarks:

SOIL

Sampling Point: 400

Profile Description: (Describe to the depth needed to document the indicator or confirm the absence of indicators.)								
Depth (inches)	Matrix		Redox Features				Texture	Remarks
	Color (moist)	%	Color (moist)	%	Type ¹	Loc ²		
0-3	7.5YR 4/3	80	10YR 7/4	20	C	M	Loam	
3-5	Gley 1, 2.5/N	90	Gley 1, 6/10Y	10			Loam	
5-7	10YR 4/1	100					Sandy clay	
7-13	10YR 4/1	100					Loamy sand	

¹Type: C=Concentration, D=Depletion, RM=Reduced Matrix, CS=Covered or Coated Sand Grains. ²Location: PL=Pore Lining, M=Matrix.

Hydric Soil Indicators: (Applicable to all LRRs, unless otherwise noted.)	Indicators for Problematic Hydric Soils³:
<input type="checkbox"/> Histosol (A1) <input type="checkbox"/> Histic Epipedon (A2) <input type="checkbox"/> Black Histic (A3) <input type="checkbox"/> Hydrogen Sulfide (A4) <input type="checkbox"/> Stratified Layers (A5) (LRR C) <input type="checkbox"/> 1 cm Muck (A9) (LRR D) <input type="checkbox"/> Depleted Below Dark Surface (A11) <input type="checkbox"/> Thick Dark Surface (A12) <input type="checkbox"/> Sandy Mucky Mineral (S1) <input type="checkbox"/> Sandy Gleyed Matrix (S4)	<input type="checkbox"/> Sandy Redox (S5) <input type="checkbox"/> Stripped Matrix (S6) <input type="checkbox"/> Loamy Mucky Mineral (F1) <input type="checkbox"/> Loamy Gleyed Matrix (F2) <input type="checkbox"/> Depleted Matrix (F3) <input type="checkbox"/> Redox Dark Surface (F6) <input type="checkbox"/> Depleted Dark Surface (F7) <input type="checkbox"/> Redox Depressions (F8) <input type="checkbox"/> Vernal Pools (F9)
	<input type="checkbox"/> 1 cm Muck (A9) (LRR C) <input type="checkbox"/> 2 cm Muck (A10) (LRR B) <input type="checkbox"/> Reduced Vertic (F18) <input type="checkbox"/> Red Parent Material (TF2) <input type="checkbox"/> Other (Explain in Remarks)

³Indicators of hydrophytic vegetation and wetland hydrology must be present, unless disturbed or problematic.

Restrictive Layer (if present): Type: _____ Depth (inches): _____	Hydric Soil Present? Yes _____ No <input checked="" type="checkbox"/>
--------------------------------------------------------------------------------	---------------------------------------------------------------------------------

Remarks:

HYDROLOGY

Wetland Hydrology Indicators:	
Primary Indicators (minimum of one required; check all that apply)	Secondary Indicators (2 or more required)
<input type="checkbox"/> Surface Water (A1) <input checked="" type="checkbox"/> High Water Table (A2) <input checked="" type="checkbox"/> Saturation (A3) <input checked="" type="checkbox"/> Water Marks (B1) (Nonriverine) <input type="checkbox"/> Sediment Deposits (B2) (Nonriverine) <input type="checkbox"/> Drift Deposits (B3) (Nonriverine) <input type="checkbox"/> Surface Soil Cracks (B6) <input type="checkbox"/> Inundation Visible on Aerial Imagery (B7) <input type="checkbox"/> Water-Stained Leaves (B9)	<input type="checkbox"/> Salt Crust (B11) <input type="checkbox"/> Biotic Crust (B12) <input type="checkbox"/> Aquatic Invertebrates (B13) <input type="checkbox"/> Hydrogen Sulfide Odor (C1) <input type="checkbox"/> Oxidized Rhizospheres along Living Roots (C3) <input type="checkbox"/> Presence of Reduced Iron (C4) <input type="checkbox"/> Recent Iron Reduction in Tilled Soils (C6) <input type="checkbox"/> Thin Muck Surface (C7) <input type="checkbox"/> Other (Explain in Remarks)
	<input type="checkbox"/> Water Marks (B1) (Riverine) <input type="checkbox"/> Sediment Deposits (B2) (Riverine) <input type="checkbox"/> Drift Deposits (B3) (Riverine) <input type="checkbox"/> Drainage Patterns (B10) <input type="checkbox"/> Dry-Season Water Table (C2) <input type="checkbox"/> Crayfish Burrows (C8) <input type="checkbox"/> Saturation Visible on Aerial Imagery (C9) <input type="checkbox"/> Shallow Aquitard (D3) <input type="checkbox"/> FAC-Neutral Test (D5)

Field Observations: Surface Water Present? Yes _____ No <input checked="" type="checkbox"/> Depth (inches): _____ Water Table Present? Yes <input checked="" type="checkbox"/> No _____ Depth (inches): <u>10</u> Saturation Present? Yes <input checked="" type="checkbox"/> No _____ Depth (inches): <u>1</u> (includes capillary fringe)	Wetland Hydrology Present? Yes <input checked="" type="checkbox"/> No _____
----------------------------------------------------------------------------------------------------------------------------------------------------------------------------------------------------------------------------------------------------------------------------------------------------------------------------------------------------------------------------------	------------------------------------------------------------------------------------

Describe Recorded Data (stream gauge, monitoring well, aerial photos, previous inspections), if available:

Remarks:

WETLAND DETERMINATION DATA FORM – Arid West Region

Project/Site: Vega SES 4 City/County: Holtville/ Imperial County Sampling Date: 11/12/2020
 Applicant/Owner: zGlobal, Inc. State: CA Sampling Point: 401
 Investigator(s): C. Congedo, C. Garcia, C. Torres Section, Township, Range: S10, T17S, R16E
 Landform (hillslope, terrace, etc.): Depression Local relief (concave, convex, none): Concave Slope (%): 10
 Subregion (LRR): D Lat: 32.680346 Long: -115.315672 Datum: NAD83
 Soil Map Unit Name: Vint loamy very fine sand, wet NWI classification: N/A

Are climatic / hydrologic conditions on the site typical for this time of year? Yes No (If no, explain in Remarks.)
 Are Vegetation , Soil , or Hydrology significantly disturbed? Are "Normal Circumstances" present? Yes No
 Are Vegetation , Soil , or Hydrology naturally problematic? (If needed, explain any answers in Remarks.)

SUMMARY OF FINDINGS – Attach site map showing sampling point locations, transects, important features, etc.

Hydrophytic Vegetation Present? Yes <input checked="" type="checkbox"/> No <input type="checkbox"/> Hydric Soil Present? Yes <input checked="" type="checkbox"/> No <input type="checkbox"/> Wetland Hydrology Present? Yes <input checked="" type="checkbox"/> No <input type="checkbox"/>	Is the Sampled Area within a Wetland? Yes <input checked="" type="checkbox"/> No <input type="checkbox"/>
Remarks: Point taken within tamarisk thickets, ~850 feet downslope (south) of a hard-packed dirt road that runs parallel to the All-American Canal.	

VEGETATION – Use scientific names of plants.

Tree Stratum (Plot size: <u>20'</u>)	Absolute % Cover	Dominant Species?	Indicator Status	
1. <u>Tamarix sp.</u>	<u>10</u>	<u>x</u>	<u>FAC</u>	Dominance Test worksheet: Number of Dominant Species That Are OBL, FACW, or FAC: <u>1</u> (A) Total Number of Dominant Species Across All Strata: <u>1</u> (B) Percent of Dominant Species That Are OBL, FACW, or FAC: <u>100</u> (A/B)
2. _____	_____	_____	_____	
3. _____	_____	_____	_____	
4. _____	_____	_____	_____	
<u>10</u> = Total Cover				Prevalence Index worksheet: Total % Cover of: _____ Multiply by: _____ OBL species <u>0</u> x 1 = <u>0</u> FACW species <u>3</u> x 2 = <u>6</u> FAC species <u>10</u> x 3 = <u>30</u> FACU species <u>0</u> x 4 = <u>0</u> UPL species <u>0</u> x 5 = <u>0</u> Column Totals: <u>13</u> (A) <u>36</u> (B) Prevalence Index = B/A = <u>2.77</u>
Sapling/Shrub Stratum (Plot size: <u>20'</u>)	Absolute % Cover	Dominant Species?	Indicator Status	
1. <u>Pluchea sericea</u>	<u>3</u>	_____	<u>FACW</u>	
2. _____	_____	_____	_____	
3. _____	_____	_____	_____	
4. _____	_____	_____	_____	
5. _____	_____	_____	_____	
<u>3</u> = Total Cover				
Herb Stratum (Plot size: _____)	Absolute % Cover	Dominant Species?	Indicator Status	
1. _____	_____	_____	_____	
2. _____	_____	_____	_____	
3. _____	_____	_____	_____	
4. _____	_____	_____	_____	
5. _____	_____	_____	_____	
6. _____	_____	_____	_____	
7. _____	_____	_____	_____	
8. _____	_____	_____	_____	
<u>0</u> = Total Cover				
Woody Vine Stratum (Plot size: _____)	Absolute % Cover	Dominant Species?	Indicator Status	
1. _____	_____	_____	_____	
2. _____	_____	_____	_____	
<u>0</u> = Total Cover				
% Bare Ground in Herb Stratum <u>87</u> % Cover of Biotic Crust _____				

Hydrophytic Vegetation Indicators:
 Dominance Test is >50%
 Prevalence Index is ≤3.0¹
 Morphological Adaptations¹ (Provide supporting data in Remarks or on a separate sheet)
 Problematic Hydrophytic Vegetation¹ (Explain)

¹Indicators of hydric soil and wetland hydrology must be present, unless disturbed or problematic.

Hydrophytic Vegetation Present? Yes No

Remarks:

SOIL

Sampling Point: 401

Profile Description: (Describe to the depth needed to document the indicator or confirm the absence of indicators.)								
Depth (inches)	Matrix		Redox Features				Texture	Remarks
	Color (moist)	%	Color (moist)	%	Type ¹	Loc ²		
0-2	10YR 2/1	100					Silty clay _h	Organic layer
2-7	7.5YR 4/4	100					Silt loam	
7-10	7.5YR 4/3	99	5YR 5/8	1	C	PL	Silt loam	
10-13+	7.5YR 4/6	85	5YR 5/8	5	C	M	Silt loam	
	Gley 1, 2.5/N	10						
¹ Type: C=Concentration, D=Depletion, RM=Reduced Matrix, CS=Covered or Coated Sand Grains. ² Location: PL=Pore Lining, M=Matrix.								
Hydric Soil Indicators: (Applicable to all LRRs, unless otherwise noted.)						Indicators for Problematic Hydric Soils³:		
<input type="checkbox"/> Histosol (A1)			<input type="checkbox"/> Sandy Redox (S5)			<input type="checkbox"/> 1 cm Muck (A9) (LRR C)		
<input type="checkbox"/> Histic Epipedon (A2)			<input type="checkbox"/> Stripped Matrix (S6)			<input type="checkbox"/> 2 cm Muck (A10) (LRR B)		
<input type="checkbox"/> Black Histic (A3)			<input type="checkbox"/> Loamy Mucky Mineral (F1)			<input type="checkbox"/> Reduced Vertic (F18)		
<input type="checkbox"/> Hydrogen Sulfide (A4)			<input type="checkbox"/> Loamy Gleyed Matrix (F2)			<input type="checkbox"/> Red Parent Material (TF2)		
<input type="checkbox"/> Stratified Layers (A5) (LRR C)			<input type="checkbox"/> Depleted Matrix (F3)			<input type="checkbox"/> Other (Explain in Remarks)		
<input type="checkbox"/> 1 cm Muck (A9) (LRR D)			<input type="checkbox"/> Redox Dark Surface (F6)			³ Indicators of hydrophytic vegetation and wetland hydrology must be present, unless disturbed or problematic.		
<input checked="" type="checkbox"/> Depleted Below Dark Surface (A11)			<input type="checkbox"/> Depleted Dark Surface (F7)					
<input type="checkbox"/> Thick Dark Surface (A12)			<input type="checkbox"/> Redox Depressions (F8)					
<input type="checkbox"/> Sandy Mucky Mineral (S1)			<input type="checkbox"/> Vernal Pools (F9)					
<input type="checkbox"/> Sandy Gleyed Matrix (S4)								
Restrictive Layer (if present):						Hydric Soil Present? Yes <input checked="" type="checkbox"/> No <input type="checkbox"/>		
Type: _____								
Depth (inches): _____								
Remarks:								

HYDROLOGY

Wetland Hydrology Indicators:					
Primary Indicators (minimum of one required; check all that apply)			Secondary Indicators (2 or more required)		
<input type="checkbox"/> Surface Water (A1)	<input type="checkbox"/> Salt Crust (B11)	<input type="checkbox"/> Water Marks (B1) (Riverine)			
<input type="checkbox"/> High Water Table (A2)	<input type="checkbox"/> Biotic Crust (B12)	<input type="checkbox"/> Sediment Deposits (B2) (Riverine)			
<input type="checkbox"/> Saturation (A3)	<input type="checkbox"/> Aquatic Invertebrates (B13)	<input type="checkbox"/> Drift Deposits (B3) (Riverine)			
<input type="checkbox"/> Water Marks (B1) (Nonriverine)	<input type="checkbox"/> Hydrogen Sulfide Odor (C1)	<input type="checkbox"/> Drainage Patterns (B10)			
<input type="checkbox"/> Sediment Deposits (B2) (Nonriverine)	<input type="checkbox"/> Oxidized Rhizospheres along Living Roots (C3)	<input type="checkbox"/> Dry-Season Water Table (C2)			
<input type="checkbox"/> Drift Deposits (B3) (Nonriverine)	<input type="checkbox"/> Presence of Reduced Iron (C4)	<input type="checkbox"/> Crayfish Burrows (C8)			
<input checked="" type="checkbox"/> Surface Soil Cracks (B6)	<input type="checkbox"/> Recent Iron Reduction in Tilled Soils (C6)	<input type="checkbox"/> Saturation Visible on Aerial Imagery (C9)			
<input type="checkbox"/> Inundation Visible on Aerial Imagery (B7)	<input type="checkbox"/> Thin Muck Surface (C7)	<input type="checkbox"/> Shallow Aquitard (D3)			
<input type="checkbox"/> Water-Stained Leaves (B9)	<input type="checkbox"/> Other (Explain in Remarks)	<input type="checkbox"/> FAC-Neutral Test (D5)			
Field Observations:			Wetland Hydrology Present? Yes <input checked="" type="checkbox"/> No <input type="checkbox"/>		
Surface Water Present?	Yes <input type="checkbox"/> No <input checked="" type="checkbox"/>	Depth (inches): _____			
Water Table Present?	Yes <input type="checkbox"/> No <input checked="" type="checkbox"/>	Depth (inches): _____			
Saturation Present? (includes capillary fringe)	Yes <input type="checkbox"/> No <input checked="" type="checkbox"/>	Depth (inches): _____			
Describe Recorded Data (stream gauge, monitoring well, aerial photos, previous inspections), if available:					
Remarks:					
Salt crust, but appears to be from agricultural runoff.					

WETLAND DETERMINATION DATA FORM – Arid West Region

Project/Site: Vega SES 4 City/County: Holtville/ Imperial County Sampling Date: 11/12/2020
 Applicant/Owner: zGlobal, Inc. State: CA Sampling Point: 402
 Investigator(s): C. Congedo, C. Garcia, C. Torres Section, Township, Range: S10, T17S, R16E
 Landform (hillslope, terrace, etc.): Depression Local relief (concave, convex, none): Concave Slope (%): 10
 Subregion (LRR): D Lat: 32.682005 Long: -115.316274 Datum: NAD83
 Soil Map Unit Name: Rositas sand, 2 to 5 percent slopes NWI classification: N/A

Are climatic / hydrologic conditions on the site typical for this time of year? Yes No (If no, explain in Remarks.)
 Are Vegetation , Soil , or Hydrology significantly disturbed? Are "Normal Circumstances" present? Yes No
 Are Vegetation , Soil , or Hydrology naturally problematic? (If needed, explain any answers in Remarks.)

SUMMARY OF FINDINGS – Attach site map showing sampling point locations, transects, important features, etc.

Hydrophytic Vegetation Present? Yes <input checked="" type="checkbox"/> No <input type="checkbox"/> Hydric Soil Present? Yes <input checked="" type="checkbox"/> No <input type="checkbox"/> Wetland Hydrology Present? Yes <input checked="" type="checkbox"/> No <input type="checkbox"/>	Is the Sampled Area within a Wetland? Yes <input checked="" type="checkbox"/> No <input type="checkbox"/>
Remarks: Point taken within tamarisk thickets, downslope (south) of a hard-packed dirt road that runs parallel to the All-American Canal.	

VEGETATION – Use scientific names of plants.

Tree Stratum (Plot size: <u>15'</u>)	Absolute % Cover	Dominant Species?	Indicator Status	
1. <u>Tamarix sp.</u>	<u>20</u>	<u>x</u>	<u>FAC</u>	Dominance Test worksheet: Number of Dominant Species That Are OBL, FACW, or FAC: <u>2</u> (A) Total Number of Dominant Species Across All Strata: <u>2</u> (B) Percent of Dominant Species That Are OBL, FACW, or FAC: <u>100</u> (A/B)
2. _____	_____	_____	_____	
3. _____	_____	_____	_____	
4. _____	_____	_____	_____	
<u>20</u> = Total Cover				
Sapling/Shrub Stratum (Plot size: <u>15'</u>)				
1. <u>Baccharis salicina</u>	<u>1</u>	_____	<u>FACW</u>	Prevalence Index worksheet: Total % Cover of: _____ Multiply by: _____ OBL species <u>0</u> x 1 = <u>0</u> FACW species <u>36</u> x 2 = <u>72</u> FAC species <u>20</u> x 3 = <u>60</u> FACU species <u>0</u> x 4 = <u>0</u> UPL species <u>0</u> x 5 = <u>0</u> Column Totals: <u>56</u> (A) <u>132</u> (B) Prevalence Index = B/A = <u>2.36</u>
2. <u>Pluchea sericea</u>	<u>35</u>	<u>x</u>	<u>FACW</u>	
3. _____	_____	_____	_____	
4. _____	_____	_____	_____	
5. _____	_____	_____	_____	
<u>36</u> = Total Cover				
Herb Stratum (Plot size: _____)				
1. _____	_____	_____	_____	Hydrophytic Vegetation Indicators: <input checked="" type="checkbox"/> Dominance Test is >50% <input checked="" type="checkbox"/> Prevalence Index is ≤3.0 ¹ <input type="checkbox"/> Morphological Adaptations ¹ (Provide supporting data in Remarks or on a separate sheet) <input type="checkbox"/> Problematic Hydrophytic Vegetation ¹ (Explain) ¹ Indicators of hydric soil and wetland hydrology must be present, unless disturbed or problematic.
2. _____	_____	_____	_____	
3. _____	_____	_____	_____	
4. _____	_____	_____	_____	
5. _____	_____	_____	_____	
6. _____	_____	_____	_____	
7. _____	_____	_____	_____	
8. _____	_____	_____	_____	
<u>0</u> = Total Cover				
Woody Vine Stratum (Plot size: _____)				
1. _____	_____	_____	_____	Hydrophytic Vegetation Present? Yes <input checked="" type="checkbox"/> No <input type="checkbox"/>
2. _____	_____	_____	_____	
<u>0</u> = Total Cover				
% Bare Ground in Herb Stratum <u>44</u> % Cover of Biotic Crust _____				

Remarks:

SOIL

Sampling Point: 402

Profile Description: (Describe to the depth needed to document the indicator or confirm the absence of indicators.)

Depth (inches)	Matrix		Redox Features				Texture	Remarks
	Color (moist)	%	Color (moist)	%	Type ¹	Loc ²		
0-3	10YR 2/1	100					Silty clay ⁴	
3-13+	10YR 4/4	94	5YR 5/8	5	C	PL, M	Sandy lo ⁴	
3-13+			Gley 1, 2.5/N	1	C	M		

¹Type: C=Concentration, D=Depletion, RM=Reduced Matrix, CS=Covered or Coated Sand Grains. ²Location: PL=Pore Lining, M=Matrix.

Hydric Soil Indicators: (Applicable to all LRRs, unless otherwise noted.)

- Histosol (A1)
- Histic Epipedon (A2)
- Black Histic (A3)
- Hydrogen Sulfide (A4)
- Stratified Layers (A5) **(LRR C)**
- 1 cm Muck (A9) **(LRR D)**
- Depleted Below Dark Surface (A11)
- Thick Dark Surface (A12)
- Sandy Mucky Mineral (S1)
- Sandy Gleyed Matrix (S4)
- Sandy Redox (S5)
- Stripped Matrix (S6)
- Loamy Mucky Mineral (F1)
- Loamy Gleyed Matrix (F2)
- Depleted Matrix (F3)
- Redox Dark Surface (F6)
- Depleted Dark Surface (F7)
- Redox Depressions (F8)
- Vernal Pools (F9)

Indicators for Problematic Hydric Soils³:

- 1 cm Muck (A9) **(LRR C)**
- 2 cm Muck (A10) **(LRR B)**
- Reduced Vertic (F18)
- Red Parent Material (TF2)
- Other (Explain in Remarks)

³Indicators of hydrophytic vegetation and wetland hydrology must be present, unless disturbed or problematic.

Restrictive Layer (if present):

Type: _____
 Depth (inches): _____

Hydric Soil Present? Yes No

Remarks:

HYDROLOGY

Wetland Hydrology Indicators:

Primary Indicators (minimum of one required; check all that apply)	Secondary Indicators (2 or more required)
<input type="checkbox"/> Surface Water (A1)	<input type="checkbox"/> Water Marks (B1) (Riverine)
<input type="checkbox"/> High Water Table (A2)	<input type="checkbox"/> Sediment Deposits (B2) (Riverine)
<input checked="" type="checkbox"/> Saturation (A3)	<input type="checkbox"/> Drift Deposits (B3) (Riverine)
<input type="checkbox"/> Water Marks (B1) (Nonriverine)	<input type="checkbox"/> Drainage Patterns (B10)
<input type="checkbox"/> Sediment Deposits (B2) (Nonriverine)	<input type="checkbox"/> Dry-Season Water Table (C2)
<input checked="" type="checkbox"/> Drift Deposits (B3) (Nonriverine)	<input type="checkbox"/> Crayfish Burrows (C8)
<input type="checkbox"/> Surface Soil Cracks (B6)	<input type="checkbox"/> Saturation Visible on Aerial Imagery (C9)
<input type="checkbox"/> Inundation Visible on Aerial Imagery (B7)	<input type="checkbox"/> Shallow Aquitard (D3)
<input type="checkbox"/> Water-Stained Leaves (B9)	<input type="checkbox"/> FAC-Neutral Test (D5)
<input type="checkbox"/> Salt Crust (B11)	
<input type="checkbox"/> Biotic Crust (B12)	
<input type="checkbox"/> Aquatic Invertebrates (B13)	
<input type="checkbox"/> Hydrogen Sulfide Odor (C1)	
<input checked="" type="checkbox"/> Oxidized Rhizospheres along Living Roots (C3)	
<input type="checkbox"/> Presence of Reduced Iron (C4)	
<input type="checkbox"/> Recent Iron Reduction in Tilled Soils (C6)	
<input type="checkbox"/> Thin Muck Surface (C7)	
<input type="checkbox"/> Other (Explain in Remarks)	

Field Observations:

Surface Water Present? Yes No Depth (inches): _____
 Water Table Present? Yes No Depth (inches): _____
 Saturation Present? (includes capillary fringe) Yes No Depth (inches): 4

Wetland Hydrology Present? Yes No

Describe Recorded Data (stream gauge, monitoring well, aerial photos, previous inspections), if available:

Remarks:

WETLAND DETERMINATION DATA FORM – Arid West Region

Project/Site: Vega SES 4 City/County: Holtville/ Imperial County Sampling Date: 11/12/2020
 Applicant/Owner: zGlobal, Inc. State: CA Sampling Point: 403
 Investigator(s): C. Congedo, C. Garcia, C. Torres Section, Township, Range: S10, T17S, R16E
 Landform (hillslope, terrace, etc.): Hillslope Local relief (concave, convex, none): Convex Slope (%): 8
 Subregion (LRR): D Lat: 32.681441 Long: -115.315429 Datum: NAD83
 Soil Map Unit Name: Rositas sand, 2 to 5 percent slopes NWI classification: N/A

Are climatic / hydrologic conditions on the site typical for this time of year? Yes No (If no, explain in Remarks.)
 Are Vegetation , Soil , or Hydrology significantly disturbed? Are "Normal Circumstances" present? Yes No
 Are Vegetation , Soil , or Hydrology naturally problematic? (If needed, explain any answers in Remarks.)

SUMMARY OF FINDINGS – Attach site map showing sampling point locations, transects, important features, etc.

Hydrophytic Vegetation Present? Yes <input type="checkbox"/> No <input checked="" type="checkbox"/> Hydric Soil Present? Yes <input type="checkbox"/> No <input checked="" type="checkbox"/> Wetland Hydrology Present? Yes <input type="checkbox"/> No <input checked="" type="checkbox"/>	Is the Sampled Area within a Wetland? Yes <input type="checkbox"/> No <input checked="" type="checkbox"/>
Remarks: Point taken within creosote bush scrub upslope of tamarisk thickets. A dirt access road exists 60 feet to the east.	

VEGETATION – Use scientific names of plants.

Tree Stratum (Plot size: _____)	Absolute % Cover	Dominant Species?	Indicator Status	
1. _____	_____	_____	_____	Dominance Test worksheet: Number of Dominant Species That Are OBL, FACW, or FAC: <u>1</u> (A) Total Number of Dominant Species Across All Strata: <u>2</u> (B) Percent of Dominant Species That Are OBL, FACW, or FAC: <u>50</u> (A/B)
2. _____	_____	_____	_____	
3. _____	_____	_____	_____	
4. _____	_____	_____	_____	
<u>0</u> = Total Cover				Prevalence Index worksheet: Total % Cover of: _____ Multiply by: _____ OBL species <u>0</u> x 1 = <u>0</u> FACW species <u>3</u> x 2 = <u>6</u> FAC species <u>0</u> x 3 = <u>0</u> FACU species <u>0</u> x 4 = <u>0</u> UPL species <u>3</u> x 5 = <u>15</u> Column Totals: <u>6</u> (A) <u>21</u> (B) Prevalence Index = B/A = <u>3.5</u>
Sapling/Shrub Stratum (Plot size: <u>15'</u>)				
1. <u>Larrea tridentata</u>	<u>3</u>	<u>x</u>	<u>N/L</u>	
2. <u>Pluchea sericea</u>	<u>3</u>	<u>x</u>	<u>FACW</u>	
3. _____	_____	_____	_____	
4. _____	_____	_____	_____	
5. _____	_____	_____	_____	
<u>6</u> = Total Cover				
Herb Stratum (Plot size: _____)				
1. _____	_____	_____	_____	
2. _____	_____	_____	_____	
3. _____	_____	_____	_____	
4. _____	_____	_____	_____	
5. _____	_____	_____	_____	
6. _____	_____	_____	_____	
7. _____	_____	_____	_____	
8. _____	_____	_____	_____	
<u>0</u> = Total Cover				
Woody Vine Stratum (Plot size: _____)				
1. _____	_____	_____	_____	
2. _____	_____	_____	_____	
<u>0</u> = Total Cover				
% Bare Ground in Herb Stratum <u>94</u>		% Cover of Biotic Crust _____		

¹Indicators of hydric soil and wetland hydrology must be present, unless disturbed or problematic.

Hydrophytic Vegetation Present? Yes No

Remarks:
 N/L species considered upland.

SOIL

Sampling Point: 403

Profile Description: (Describe to the depth needed to document the indicator or confirm the absence of indicators.)								
Depth (inches)	Matrix		Redox Features				Texture	Remarks
	Color (moist)	%	Color (moist)	%	Type ¹	Loc ²		
0-7	10YR 4/4	98	5YR 5/8	1	C	M	Loamy sand	
0-7			7.5YR 9.5/1	1	C	M		
7-12+	10YR 4/4	85	5YR 5/4	5	C	M	Clay loam	
7-12+	10Y 6/4	2	7.5YR 9.5/1	8			Clay loam	

¹Type: C=Concentration, D=Depletion, RM=Reduced Matrix, CS=Covered or Coated Sand Grains. ²Location: PL=Pore Lining, M=Matrix.

Hydric Soil Indicators: (Applicable to all LRRs, unless otherwise noted.)	Indicators for Problematic Hydric Soils ³ :
<input type="checkbox"/> Histosol (A1)	<input type="checkbox"/> 1 cm Muck (A9) (LRR C)
<input type="checkbox"/> Histic Epipedon (A2)	<input type="checkbox"/> 2 cm Muck (A10) (LRR B)
<input type="checkbox"/> Black Histic (A3)	<input type="checkbox"/> Reduced Vertic (F18)
<input type="checkbox"/> Hydrogen Sulfide (A4)	<input type="checkbox"/> Red Parent Material (TF2)
<input type="checkbox"/> Stratified Layers (A5) (LRR C)	<input type="checkbox"/> Other (Explain in Remarks)
<input type="checkbox"/> 1 cm Muck (A9) (LRR D)	
<input type="checkbox"/> Depleted Below Dark Surface (A11)	
<input type="checkbox"/> Thick Dark Surface (A12)	
<input type="checkbox"/> Sandy Mucky Mineral (S1)	
<input type="checkbox"/> Sandy Gleyed Matrix (S4)	
<input type="checkbox"/> Sandy Redox (S5)	
<input type="checkbox"/> Stripped Matrix (S6)	
<input type="checkbox"/> Loamy Mucky Mineral (F1)	
<input type="checkbox"/> Loamy Gleyed Matrix (F2)	
<input type="checkbox"/> Depleted Matrix (F3)	
<input type="checkbox"/> Redox Dark Surface (F6)	
<input type="checkbox"/> Depleted Dark Surface (F7)	
<input type="checkbox"/> Redox Depressions (F8)	
<input type="checkbox"/> Vernal Pools (F9)	

³Indicators of hydrophytic vegetation and wetland hydrology must be present, unless disturbed or problematic.

Restrictive Layer (if present): Type: _____ Depth (inches): _____	Hydric Soil Present? Yes _____ No <input checked="" type="checkbox"/>
--------------------------------------------------------------------------------	------------------------------------------------------------------------------

Remarks:

HYDROLOGY

Wetland Hydrology Indicators:	
Primary Indicators (minimum of one required; check all that apply)	Secondary Indicators (2 or more required)
<input type="checkbox"/> Surface Water (A1)	<input type="checkbox"/> Salt Crust (B11)
<input type="checkbox"/> High Water Table (A2)	<input type="checkbox"/> Biotic Crust (B12)
<input type="checkbox"/> Saturation (A3)	<input type="checkbox"/> Aquatic Invertebrates (B13)
<input type="checkbox"/> Water Marks (B1) (Nonriverine)	<input type="checkbox"/> Hydrogen Sulfide Odor (C1)
<input type="checkbox"/> Sediment Deposits (B2) (Nonriverine)	<input type="checkbox"/> Oxidized Rhizospheres along Living Roots (C3)
<input type="checkbox"/> Drift Deposits (B3) (Nonriverine)	<input type="checkbox"/> Presence of Reduced Iron (C4)
<input type="checkbox"/> Surface Soil Cracks (B6)	<input type="checkbox"/> Recent Iron Reduction in Tilled Soils (C6)
<input type="checkbox"/> Inundation Visible on Aerial Imagery (B7)	<input type="checkbox"/> Thin Muck Surface (C7)
<input type="checkbox"/> Water-Stained Leaves (B9)	<input type="checkbox"/> Other (Explain in Remarks)
<input type="checkbox"/> Water Marks (B1) (Riverine)	<input type="checkbox"/> Water Marks (B1) (Riverine)
<input type="checkbox"/> Sediment Deposits (B2) (Riverine)	<input type="checkbox"/> Sediment Deposits (B2) (Riverine)
<input type="checkbox"/> Drift Deposits (B3) (Riverine)	<input type="checkbox"/> Drift Deposits (B3) (Riverine)
<input type="checkbox"/> Drainage Patterns (B10)	<input type="checkbox"/> Drainage Patterns (B10)
<input type="checkbox"/> Dry-Season Water Table (C2)	<input type="checkbox"/> Dry-Season Water Table (C2)
<input type="checkbox"/> Crayfish Burrows (C8)	<input type="checkbox"/> Crayfish Burrows (C8)
<input type="checkbox"/> Saturation Visible on Aerial Imagery (C9)	<input type="checkbox"/> Saturation Visible on Aerial Imagery (C9)
<input type="checkbox"/> Shallow Aquitard (D3)	<input type="checkbox"/> Shallow Aquitard (D3)
<input type="checkbox"/> FAC-Neutral Test (D5)	<input type="checkbox"/> FAC-Neutral Test (D5)

Field Observations: Surface Water Present? Yes _____ No _____ Depth (inches): _____ Water Table Present? Yes _____ No _____ Depth (inches): _____ Saturation Present? (includes capillary fringe) Yes _____ No _____ Depth (inches): _____	Wetland Hydrology Present? Yes _____ No <input checked="" type="checkbox"/>
------------------------------------------------------------------------------------------------------------------------------------------------------------------------------------------------------------------------------------------------------------	------------------------------------------------------------------------------------

Describe Recorded Data (stream gauge, monitoring well, aerial photos, previous inspections), if available:

Remarks:

WETLAND DETERMINATION DATA FORM – Arid West Region

Project/Site: Vega SES 4 City/County: Holtville/ Imperial County Sampling Date: 11/12/2020
 Applicant/Owner: zGlobal, Inc. State: _____ Sampling Point: 404
 Investigator(s): C. Congedo, C. Garcia, C. Torres Section, Township, Range: S15, T17S, R16E
 Landform (hillslope, terrace, etc.): Slope Local relief (concave, convex, none): Concave Slope (%): 5
 Subregion (LRR): D Lat: 32.679516 Long: -115.318349 Datum: NAD83
 Soil Map Unit Name: Badland NWI classification: N/A

Are climatic / hydrologic conditions on the site typical for this time of year? Yes No _____ (If no, explain in Remarks.)
 Are Vegetation _____, Soil _____, or Hydrology _____ significantly disturbed? Are "Normal Circumstances" present? Yes No _____
 Are Vegetation _____, Soil _____, or Hydrology _____ naturally problematic? (If needed, explain any answers in Remarks.)

SUMMARY OF FINDINGS – Attach site map showing sampling point locations, transects, important features, etc.

Hydrophytic Vegetation Present? Yes <input checked="" type="checkbox"/> No _____ Hydric Soil Present? Yes <input checked="" type="checkbox"/> No _____ Wetland Hydrology Present? Yes <input checked="" type="checkbox"/> No _____	Is the Sampled Area within a Wetland? Yes <input checked="" type="checkbox"/> No _____
Remarks: Point taken within a relatively flat area in alkali weed- salt grass playas and sinks habitat.	

VEGETATION – Use scientific names of plants.

Tree Stratum (Plot size: <u>20'</u>)	Absolute % Cover	Dominant Species?	Indicator Status	
1. <u>Tamarix sp.</u>	<u>2</u>		<u>FAC</u>	Dominance Test worksheet: Number of Dominant Species That Are OBL, FACW, or FAC: <u>1</u> (A) Total Number of Dominant Species Across All Strata: <u>1</u> (B) Percent of Dominant Species That Are OBL, FACW, or FAC: <u>100</u> (A/B)
2. _____				
3. _____				
4. _____				
<u>2</u> = Total Cover				Prevalence Index worksheet: Total % Cover of: _____ Multiply by: _____ OBL species <u>0</u> x 1 = <u>0</u> FACW species <u>5</u> x 2 = <u>10</u> FAC species <u>2</u> x 3 = <u>6</u> FACU species <u>0</u> x 4 = <u>0</u> UPL species <u>0</u> x 5 = <u>0</u> Column Totals: <u>7</u> (A) <u>16</u> (B) Prevalence Index = B/A = <u>2.29</u>
<u>Sapling/Shrub Stratum (Plot size: <u>20'</u>)</u>				
1. <u>Pluchea sericea</u>	<u>5</u>	<u>x</u>	<u>FACW</u>	
2. _____				
3. _____				
4. _____				
5. _____				
<u>5</u> = Total Cover				Hydrophytic Vegetation Indicators: <input checked="" type="checkbox"/> Dominance Test is >50% <input checked="" type="checkbox"/> Prevalence Index is ≤3.0 ¹ <input type="checkbox"/> Morphological Adaptations ¹ (Provide supporting data in Remarks or on a separate sheet) <input type="checkbox"/> Problematic Hydrophytic Vegetation ¹ (Explain) ¹ Indicators of hydric soil and wetland hydrology must be present, unless disturbed or problematic.
<u>Herb Stratum (Plot size: _____)</u>				
1. _____				
2. _____				
3. _____				
4. _____				
5. _____				
6. _____				
7. _____				
8. _____				
<u>0</u> = Total Cover				Hydrophytic Vegetation Present? Yes <input checked="" type="checkbox"/> No _____
<u>Woody Vine Stratum (Plot size: _____)</u>				
1. _____				
2. _____				
<u>0</u> = Total Cover				
% Bare Ground in Herb Stratum <u>93</u> % Cover of Biotic Crust _____				
Remarks:				

SOIL

Sampling Point: 404

Profile Description: (Describe to the depth needed to document the indicator or confirm the absence of indicators.)								
Depth (inches)	Matrix		Redox Features				Texture	Remarks
	Color (moist)	%	Color (moist)	%	Type ¹	Loc ²		
0-1	10YR 3/3	100					Silt loam	
1-3	10YR 2/1	100					Loam	
3-4	7.5YR 4/3	99	7.5YR 8/2	1	C	M	Silty clay _h	
4-12+	10YR 8/2	5	White pg, 9.5/N	15	C	M	Clay	
4-12+	7.5YR 4/4	75	5YR 5/8	5	C	M	Clay	
¹ Type: C=Concentration, D=Depletion, RM=Reduced Matrix, CS=Covered or Coated Sand Grains. ² Location: PL=Pore Lining, M=Matrix.								
Hydric Soil Indicators: (Applicable to all LRRs, unless otherwise noted.)						Indicators for Problematic Hydric Soils³:		
<input type="checkbox"/> Histosol (A1)			<input type="checkbox"/> Sandy Redox (S5)			<input type="checkbox"/> 1 cm Muck (A9) (LRR C)		
<input type="checkbox"/> Histic Epipedon (A2)			<input type="checkbox"/> Stripped Matrix (S6)			<input type="checkbox"/> 2 cm Muck (A10) (LRR B)		
<input type="checkbox"/> Black Histic (A3)			<input type="checkbox"/> Loamy Mucky Mineral (F1)			<input type="checkbox"/> Reduced Vertic (F18)		
<input type="checkbox"/> Hydrogen Sulfide (A4)			<input type="checkbox"/> Loamy Gleyed Matrix (F2)			<input type="checkbox"/> Red Parent Material (TF2)		
<input type="checkbox"/> Stratified Layers (A5) (LRR C)			<input checked="" type="checkbox"/> Depleted Matrix (F3)			<input type="checkbox"/> Other (Explain in Remarks)		
<input type="checkbox"/> 1 cm Muck (A9) (LRR D)			<input type="checkbox"/> Redox Dark Surface (F6)			³ Indicators of hydrophytic vegetation and wetland hydrology must be present, unless disturbed or problematic.		
<input type="checkbox"/> Depleted Below Dark Surface (A11)			<input type="checkbox"/> Depleted Dark Surface (F7)					
<input type="checkbox"/> Thick Dark Surface (A12)			<input checked="" type="checkbox"/> Redox Depressions (F8)					
<input type="checkbox"/> Sandy Mucky Mineral (S1)			<input type="checkbox"/> Vernal Pools (F9)					
<input type="checkbox"/> Sandy Gleyed Matrix (S4)								
Restrictive Layer (if present):								
Type: _____								
Depth (inches): _____						Hydric Soil Present? Yes <input checked="" type="checkbox"/> No <input type="checkbox"/>		
Remarks:								

HYDROLOGY

Wetland Hydrology Indicators:		
Primary Indicators (minimum of one required; check all that apply)	Secondary Indicators (2 or more required)	
<input type="checkbox"/> Surface Water (A1)	<input type="checkbox"/> Salt Crust (B11)	<input type="checkbox"/> Water Marks (B1) (Riverine)
<input type="checkbox"/> High Water Table (A2)	<input type="checkbox"/> Biotic Crust (B12)	<input type="checkbox"/> Sediment Deposits (B2) (Riverine)
<input type="checkbox"/> Saturation (A3)	<input type="checkbox"/> Aquatic Invertebrates (B13)	<input type="checkbox"/> Drift Deposits (B3) (Riverine)
<input type="checkbox"/> Water Marks (B1) (Nonriverine)	<input type="checkbox"/> Hydrogen Sulfide Odor (C1)	<input checked="" type="checkbox"/> Drainage Patterns (B10)
<input type="checkbox"/> Sediment Deposits (B2) (Nonriverine)	<input type="checkbox"/> Oxidized Rhizospheres along Living Roots (C3)	<input type="checkbox"/> Dry-Season Water Table (C2)
<input type="checkbox"/> Drift Deposits (B3) (Nonriverine)	<input type="checkbox"/> Presence of Reduced Iron (C4)	<input type="checkbox"/> Crayfish Burrows (C8)
<input checked="" type="checkbox"/> Surface Soil Cracks (B6)	<input type="checkbox"/> Recent Iron Reduction in Tilled Soils (C6)	<input type="checkbox"/> Saturation Visible on Aerial Imagery (C9)
<input type="checkbox"/> Inundation Visible on Aerial Imagery (B7)	<input type="checkbox"/> Thin Muck Surface (C7)	<input type="checkbox"/> Shallow Aquitard (D3)
<input type="checkbox"/> Water-Stained Leaves (B9)	<input type="checkbox"/> Other (Explain in Remarks)	<input type="checkbox"/> FAC-Neutral Test (D5)
Field Observations:		
Surface Water Present? Yes <input type="checkbox"/> No <input checked="" type="checkbox"/>	Depth (inches): _____	Wetland Hydrology Present? Yes <input checked="" type="checkbox"/> No <input type="checkbox"/>
Water Table Present? Yes <input type="checkbox"/> No <input checked="" type="checkbox"/>	Depth (inches): _____	
Saturation Present? (includes capillary fringe) Yes <input type="checkbox"/> No <input checked="" type="checkbox"/>	Depth (inches): _____	
Describe Recorded Data (stream gauge, monitoring well, aerial photos, previous inspections), if available:		
Remarks:		

WETLAND DETERMINATION DATA FORM – Arid West Region

Project/Site: Vega SES 4 City/County: Holtville/ Imperial County Sampling Date: 4/13/2022
 Applicant/Owner: zGlobal, Inc. State: CA Sampling Point: 501
 Investigator(s): C. Torres, C. Garcia Section, Township, Range: S11 T17S R18E
 Landform (hillslope, terrace, etc.): Slight slope Local relief (concave, convex, none): None Slope (%): 5
 Subregion (LRR): D Lat: 32.693371 Long: -115.100871 Datum: NAD83
 Soil Map Unit Name: 135: Rositas fine sand, wet, 0 to 2 percent slopes (455524) NWI classification: N/A
 Are climatic / hydrologic conditions on the site typical for this time of year? Yes No (If no, explain in Remarks.)
 Are Vegetation , Soil , or Hydrology significantly disturbed? Are "Normal Circumstances" present? Yes No
 Are Vegetation , Soil , or Hydrology naturally problematic? (If needed, explain any answers in Remarks.)

SUMMARY OF FINDINGS – Attach site map showing sampling point locations, transects, important features, etc.

Hydrophytic Vegetation Present? Yes <input checked="" type="checkbox"/> No <input type="checkbox"/> Hydric Soil Present? Yes <input type="checkbox"/> No <input checked="" type="checkbox"/> Wetland Hydrology Present? Yes <input type="checkbox"/> No <input checked="" type="checkbox"/>	Is the Sampled Area within a Wetland? Yes <input type="checkbox"/> No <input checked="" type="checkbox"/>
Remarks: Sample point taken within tamarisk thickets, in an area that appears to be a remnant wetland due to high amount of dead tamarisk. Likely a remnant finger of what appears to be a currently active wetland (assumption made based on healthy tamarisk present throughout area) located directly northwest of the Study Area.	

VEGETATION – Use scientific names of plants.

Tree Stratum (Plot size: <u>30'</u>)	Absolute % Cover	Dominant Species?	Indicator Status	
1. _____	_____	_____	_____	Dominance Test worksheet: Number of Dominant Species That Are OBL, FACW, or FAC: <u>1</u> (A) Total Number of Dominant Species Across All Strata: <u>1</u> (B) Percent of Dominant Species That Are OBL, FACW, or FAC: <u>100</u> (A/B)
2. _____	_____	_____	_____	
3. _____	_____	_____	_____	
4. _____	_____	_____	_____	
<u>0</u> = Total Cover				Prevalence Index worksheet: Total % Cover of: _____ Multiply by: _____ OBL species <u>0</u> x 1 = <u>0</u> FACW species <u>2</u> x 2 = <u>4</u> FAC species <u>3</u> x 3 = <u>9</u> FACU species <u>1</u> x 4 = <u>4</u> UPL species <u>1</u> x 5 = <u>5</u> Column Totals: <u>7</u> (A) <u>22</u> (B) Prevalence Index = B/A = <u>3.14</u>
Sapling/Shrub Stratum (Plot size: <u>30'</u>)				
1. <u>Tamarix sp.</u>	<u>3</u>	<u>Yes</u>	<u>FAC</u>	
2. <u>Pluchea sericea</u>	<u>2</u>	<u>No</u>	<u>FACW</u>	
3. <u>Larrea tridentata</u>	<u>1</u>	<u>No</u>	<u>N/L</u>	
4. <u>Isocoma acradenia</u>	<u>1</u>	<u>No</u>	<u>FACU</u>	
5. _____	_____	_____	_____	
<u>7</u> = Total Cover				
Herb Stratum (Plot size: <u>30'</u>)				
1. _____	_____	_____	_____	
2. _____	_____	_____	_____	
3. _____	_____	_____	_____	
4. _____	_____	_____	_____	
5. _____	_____	_____	_____	
6. _____	_____	_____	_____	
7. _____	_____	_____	_____	
8. _____	_____	_____	_____	
<u>0</u> = Total Cover				
Woody Vine Stratum (Plot size: <u>30'</u>)				
1. _____	_____	_____	_____	
2. _____	_____	_____	_____	
<u>0</u> = Total Cover				
% Bare Ground in Herb Stratum <u>86</u>		% Cover of Biotic Crust <u>0</u>		
Remarks: Dead tamarisk within plot at 7% cover.				
Hydrophytic Vegetation Indicators: <input checked="" type="checkbox"/> Dominance Test is >50% <input type="checkbox"/> Prevalence Index is ≤3.0 ¹ <input type="checkbox"/> Morphological Adaptations ¹ (Provide supporting data in Remarks or on a separate sheet) <input type="checkbox"/> Problematic Hydrophytic Vegetation ¹ (Explain)				
¹ Indicators of hydric soil and wetland hydrology must be present, unless disturbed or problematic.				
Hydrophytic Vegetation Present? Yes <input checked="" type="checkbox"/> No <input type="checkbox"/>				

SOIL

Sampling Point: 501

Profile Description: (Describe to the depth needed to document the indicator or confirm the absence of indicators.)								
Depth (inches)	Matrix		Redox Features				Texture	Remarks
	Color (moist)	%	Color (moist)	%	Type ¹	Loc ²		
0-14+	7.5YR 4/4	100					Snd Lm	
¹ Type: C=Concentration, D=Depletion, RM=Reduced Matrix, CS=Covered or Coated Sand Grains. ² Location: PL=Pore Lining, M=Matrix.								
Hydric Soil Indicators: (Applicable to all LRRs, unless otherwise noted.)						Indicators for Problematic Hydric Soils³:		
___ Histosol (A1)		___ Sandy Redox (S5)		___ 1 cm Muck (A9) (LRR C)				
___ Histic Epipedon (A2)		___ Stripped Matrix (S6)		___ 2 cm Muck (A10) (LRR B)				
___ Black Histic (A3)		___ Loamy Mucky Mineral (F1)		___ Reduced Vertic (F18)				
___ Hydrogen Sulfide (A4)		___ Loamy Gleyed Matrix (F2)		___ Red Parent Material (TF2)				
___ Stratified Layers (A5) (LRR C)		___ Depleted Matrix (F3)		___ Other (Explain in Remarks)				
___ 1 cm Muck (A9) (LRR D)		___ Redox Dark Surface (F6)		³ Indicators of hydrophytic vegetation and wetland hydrology must be present, unless disturbed or problematic.				
___ Depleted Below Dark Surface (A11)		___ Depleted Dark Surface (F7)						
___ Thick Dark Surface (A12)		___ Redox Depressions (F8)						
___ Sandy Mucky Mineral (S1)		___ Vernal Pools (F9)						
___ Sandy Gleyed Matrix (S4)								
Restrictive Layer (if present):						Hydric Soil Present? Yes <input type="checkbox"/> No <input checked="" type="checkbox"/>		
Type: _____ Depth (inches): _____								
Remarks:								

HYDROLOGY

Wetland Hydrology Indicators:					
Primary Indicators (minimum of one required; check all that apply)			Secondary Indicators (2 or more required)		
___ Surface Water (A1)	___ Salt Crust (B11)	___ Water Marks (B1) (Riverine)			
___ High Water Table (A2)	___ Biotic Crust (B12)	___ Sediment Deposits (B2) (Riverine)			
___ Saturation (A3)	___ Aquatic Invertebrates (B13)	___ Drift Deposits (B3) (Riverine)			
___ Water Marks (B1) (Nonriverine)	___ Hydrogen Sulfide Odor (C1)	___ Drainage Patterns (B10)			
___ Sediment Deposits (B2) (Nonriverine)	___ Oxidized Rhizospheres along Living Roots (C3)	___ Dry-Season Water Table (C2)			
___ Drift Deposits (B3) (Nonriverine)	___ Presence of Reduced Iron (C4)	___ Crayfish Burrows (C8)			
___ Surface Soil Cracks (B6)	___ Recent Iron Reduction in Tilled Soils (C6)	___ Saturation Visible on Aerial Imagery (C9)			
___ Inundation Visible on Aerial Imagery (B7)	___ Thin Muck Surface (C7)	___ Shallow Aquitard (D3)			
___ Water-Stained Leaves (B9)	___ Other (Explain in Remarks)	___ FAC-Neutral Test (D5)			
Field Observations:			Wetland Hydrology Present? Yes <input type="checkbox"/> No <input checked="" type="checkbox"/>		
Surface Water Present?	Yes <input type="checkbox"/> No <input checked="" type="checkbox"/>	Depth (inches): _____			
Water Table Present?	Yes <input type="checkbox"/> No <input checked="" type="checkbox"/>	Depth (inches): _____			
Saturation Present? (includes capillary fringe)	Yes <input type="checkbox"/> No <input checked="" type="checkbox"/>	Depth (inches): _____			
Describe Recorded Data (stream gauge, monitoring well, aerial photos, previous inspections), if available:					
Remarks:					

WETLAND DETERMINATION DATA FORM – Arid West Region

Project/Site: Vega SES 4 City/County: Holtville/ Imperial County Sampling Date: 4/13/2022
 Applicant/Owner: zGlobal, Inc. State: CA Sampling Point: 502
 Investigator(s): C. Torres, C. Garcia Section, Township, Range: S10 T17S R18E
 Landform (hillslope, terrace, etc.): Slight slope Local relief (concave, convex, none): None Slope (%): 5
 Subregion (LRR): D Lat: 32.692830 Long: -115.109709 Datum: NAD83
 Soil Map Unit Name: 135: Rositas fine sand, wet, 0 to 2 percent slopes (455524) NWI classification: N/A

Are climatic / hydrologic conditions on the site typical for this time of year? Yes No (If no, explain in Remarks.)
 Are Vegetation , Soil , or Hydrology significantly disturbed? Are "Normal Circumstances" present? Yes No
 Are Vegetation , Soil , or Hydrology naturally problematic? (If needed, explain any answers in Remarks.)

SUMMARY OF FINDINGS – Attach site map showing sampling point locations, transects, important features, etc.

Hydrophytic Vegetation Present? Yes <input type="checkbox"/> No <input checked="" type="checkbox"/> Hydric Soil Present? Yes <input type="checkbox"/> No <input checked="" type="checkbox"/> Wetland Hydrology Present? Yes <input checked="" type="checkbox"/> No <input type="checkbox"/>	Is the Sampled Area within a Wetland? Yes <input type="checkbox"/> No <input checked="" type="checkbox"/>
Remarks: Sample point taken within tamarisk thickets, in an area that appears to be a remnant wetland due to high amount of dead tamarisk. Likely a remnant finger of what appears to be a currently active wetland (assumption made based on healthy tamarisk present throughout area) located directly northwest of the Study Area.	

VEGETATION – Use scientific names of plants.

Tree Stratum (Plot size: <u>30'</u>)	Absolute % Cover	Dominant Species?	Indicator Status	
1. <u>Tamarix sp.</u>	<u>5</u>	<u>Yes</u>	<u>FAC</u>	Dominance Test worksheet: Number of Dominant Species That Are OBL, FACW, or FAC: <u>1</u> (A) Total Number of Dominant Species Across All Strata: <u>2</u> (B) Percent of Dominant Species That Are OBL, FACW, or FAC: <u>50</u> (A/B)
2. _____	_____	_____	_____	
3. _____	_____	_____	_____	
4. _____	_____	_____	_____	
<u>5</u> = Total Cover				
Sapling/Shrub Stratum (Plot size: <u>30'</u>)				
1. <u>Ambrosia dumosa</u>	<u>3</u>	<u>Yes</u>	<u>N/L</u>	Prevalence Index worksheet: Total % Cover of: _____ Multiply by: _____ OBL species <u>0</u> x 1 = <u>0</u> FACW species <u>1</u> x 2 = <u>2</u> FAC species <u>5</u> x 3 = <u>15</u> FACU species <u>0</u> x 4 = <u>0</u> UPL species <u>3</u> x 5 = <u>15</u> Column Totals: <u>9</u> (A) <u>32</u> (B) Prevalence Index = B/A = <u>3.55</u>
2. <u>Pluchea sericea</u>	<u>1</u>	<u>No</u>	<u>FACW</u>	
3. _____	_____	_____	_____	
4. _____	_____	_____	_____	
5. _____	_____	_____	_____	
<u>4</u> = Total Cover				
Herb Stratum (Plot size: <u>30'</u>)				
1. _____	_____	_____	_____	Hydrophytic Vegetation Indicators: <input type="checkbox"/> Dominance Test is >50% <input type="checkbox"/> Prevalence Index is ≤3.0 ¹ <input type="checkbox"/> Morphological Adaptations ¹ (Provide supporting data in Remarks or on a separate sheet) <input type="checkbox"/> Problematic Hydrophytic Vegetation ¹ (Explain)
2. _____	_____	_____	_____	
3. _____	_____	_____	_____	
4. _____	_____	_____	_____	
5. _____	_____	_____	_____	
6. _____	_____	_____	_____	
7. _____	_____	_____	_____	
8. _____	_____	_____	_____	
<u>0</u> = Total Cover				
Woody Vine Stratum (Plot size: <u>30'</u>)				
1. _____	_____	_____	_____	¹ Indicators of hydric soil and wetland hydrology must be present, unless disturbed or problematic.
2. _____	_____	_____	_____	
<u>0</u> = Total Cover				
% Bare Ground in Herb Stratum <u>86</u> % Cover of Biotic Crust <u>0</u>				
Hydrophytic Vegetation Present? Yes <input type="checkbox"/> No <input checked="" type="checkbox"/>				

Remarks:
 Dead tamarisk within plot at 5% cover.

SOIL

Sampling Point: 502

Profile Description: (Describe to the depth needed to document the indicator or confirm the absence of indicators.)

Depth (inches)	Matrix		Redox Features				Texture	Remarks
	Color (moist)	%	Color (moist)	%	Type ¹	Loc ²		
0-14+	7.5YR 4/6	100					Snd Lm	

¹Type: C=Concentration, D=Depletion, RM=Reduced Matrix, CS=Covered or Coated Sand Grains. ²Location: PL=Pore Lining, M=Matrix.

Hydric Soil Indicators: (Applicable to all LRRs, unless otherwise noted.)

- Histosol (A1)
- Histic Epipedon (A2)
- Black Histic (A3)
- Hydrogen Sulfide (A4)
- Stratified Layers (A5) **(LRR C)**
- 1 cm Muck (A9) **(LRR D)**
- Depleted Below Dark Surface (A11)
- Thick Dark Surface (A12)
- Sandy Mucky Mineral (S1)
- Sandy Gleyed Matrix (S4)

- Sandy Redox (S5)
- Stripped Matrix (S6)
- Loamy Mucky Mineral (F1)
- Loamy Gleyed Matrix (F2)
- Depleted Matrix (F3)
- Redox Dark Surface (F6)
- Depleted Dark Surface (F7)
- Redox Depressions (F8)
- Vernal Pools (F9)

Indicators for Problematic Hydric Soils³:

- 1 cm Muck (A9) **(LRR C)**
- 2 cm Muck (A10) **(LRR B)**
- Reduced Vertic (F18)
- Red Parent Material (TF2)
- Other (Explain in Remarks)

³Indicators of hydrophytic vegetation and wetland hydrology must be present, unless disturbed or problematic.

Restrictive Layer (if present):

Type: _____
Depth (inches): _____

Hydric Soil Present? Yes _____ No

Remarks:

HYDROLOGY

Wetland Hydrology Indicators:

Primary Indicators (minimum of one required; check all that apply)

- Surface Water (A1)
- High Water Table (A2)
- Saturation (A3)
- Water Marks (B1) **(Nonriverine)**
- Sediment Deposits (B2) **(Nonriverine)**
- Drift Deposits (B3) **(Nonriverine)**
- Surface Soil Cracks (B6)
- Inundation Visible on Aerial Imagery (B7)
- Water-Stained Leaves (B9)

- Salt Crust (B11)
- Biotic Crust (B12)
- Aquatic Invertebrates (B13)
- Hydrogen Sulfide Odor (C1)
- Oxidized Rhizospheres along Living Roots (C3)
- Presence of Reduced Iron (C4)
- Recent Iron Reduction in Tilled Soils (C6)
- Thin Muck Surface (C7)
- Other (Explain in Remarks)

Secondary Indicators (2 or more required)

- Water Marks (B1) **(Riverine)**
- Sediment Deposits (B2) **(Riverine)**
- Drift Deposits (B3) **(Riverine)**
- Drainage Patterns (B10)
- Dry-Season Water Table (C2)
- Crayfish Burrows (C8)
- Saturation Visible on Aerial Imagery (C9)
- Shallow Aquitard (D3)
- FAC-Neutral Test (D5)

Field Observations:

Surface Water Present? Yes _____ No Depth (inches): _____
Water Table Present? Yes _____ No Depth (inches): _____
Saturation Present? Yes _____ No Depth (inches): _____
(includes capillary fringe)

Wetland Hydrology Present? Yes No _____

Describe Recorded Data (stream gauge, monitoring well, aerial photos, previous inspections), if available:

Remarks:

Representative Site Photographs

Attachment C. Representative Site Photographs



Photo 1. View of the All-American Canal along the northern boundary of the site; photo taken facing west. September 28, 2020.



Photo 2. Vegetation lining the bed of PD-1. Photo taken along northern portion of PD-1, facing northwest. November 5, 2020.

Attachment C. Representative Site Photographs



Photo 3. Soil pit sample for Sampling Point 2 taken within the bed of PD-1. November 4, 2020.



Photo 4. Upstream view of ED-1. Photo taken within northern portion of ED-1, facing northwest. November 5, 2020.

Attachment C. Representative Site Photographs



Photo 5. Downstream view of ED-2. Photo taken within northern portion of ED-2, facing south. November 5, 2020.



Photo 6. Downstream view of ED-3. Photo taken within northern portion of ED-3, facing southeast. November 5, 2020.

Attachment C. Representative Site Photographs



Photo 7. Sample Point 7 taken within the northeastern portion of FSW-3. November 5, 2020.



Photo 8. Sample Point 402 taken within the northeastern portion of FSW-1; photo taken facing southwest. November 5, 2020.

Attachment C. Representative Site Photographs



Photo 9. View of riparian habitat within the Study Area buffer and associated with sample point 501. Due to hydrology and vegetation observed, this area is potentially a remnant wetland. Photo taken facing south. April 12, 2022.



Photo 10. View of the All-American Canal as it flows beneath the access road bridge in the eastern portion of the Study Area. Photo taken facing west. April 12, 2022.

Attachment C. Representative Site Photographs



Photo 11. View of the Off-line Storage Canal as it flows beneath the access road bridge in the eastern portion of the Study Area. Photo taken facing southeast. April 12, 2022.



Photo 12. View of ED-8 within the Study Area buffer and north of the access road. Photo taken facing north. April 13, 2022.

ATTACHMENT D

USACE ORM Aquatic Resources Table
(Provided as an accompanying electronic file)

ATTACHMENT E

Digital Data
(Provided as accompanying electronic files)

Appendix F

Cultural Resources Inventory
(CONFIDENTIAL)

This page is intentionally blank.

Note: Appendix F, Cultural Resources Inventory, is being submitted under a CONFIDENTIAL filing and is not for public disclosure. As such, this report does not appear here.

This page is intentionally blank.

**PRELIMINARY GEOLOGICAL AND GEOTECHNICAL
HAZARD EVALUATION REPORT
VEGA 4
Imperial County, California**

June 3, 2021

Prepared for:

**Imperial County
Planning & Development Services Department**

Prepared by:

HDR Engineering, Inc.
3230 El Camino Real, Suite 200
Irvine, CA 92602



PC ORIGINAL PKG

Table of Contents

1.0	Introduction	1-1
1.1	Project Description	1-1
1.2	Site Location and Description.....	1-1
1.3	Purpose and Scope.....	1-1
2.0	Geology, Faulting and Seismicity.....	2-1
2.1	Regional Geologic Setting.....	2-1
2.2	Surface Subgrade soils and Groundwater Conditions.....	2-1
2.3	Faulting.....	2-1
2.4	Historical Seismicity	2-2
3.0	Assessment of Potential Geologic and Geotechnical Hazards	3-1
3.1	Seismic shaking	3-1
3.2	Fault-rupture hazard	3-1
3.3	Flood hazard and Tsunamis	3-1
3.4	Landsliding	3-2
3.5	Liquefaction/Seismic Settlement	3-2
3.6	Lateral spreading.....	3-2
3.7	Land Subsidence.....	3-2
3.8	Expansive soils.....	3-3
3.9	Collapsible soils.....	3-3
3.10	Soil Corrosion.....	3-3
3.11	Other Geologic hazards	3-3
4.0	Preliminary Seismic Design Recommendations.....	4-1
5.0	Conclusions and Limitations	5-1
6.0	References.....	6-1

List of Tables

Table 2-1.	Contributing Faults.....	2-2
Table 2-2.	List of Selected Historic Earthquakes	2-3
Table 4-1.	Preliminary Seismic Design Parameters	4-1

List of Appendices

Appendix A Figures

1.0 INTRODUCTION

1.1 PROJECT DESCRIPTION

It is our understanding that the proposed VEGA 4 Project will consist of the design and construction of a 100-megawatt solar photovoltaic energy facility with an integrated 100-megawatt battery storage system to provide a renewable and reliable source of electrical power. Project components will include ground mounted PV solar power generating system, supporting structures, on-site substation, battery storage system, interconnection facilities, and internal access roads. The project would employ PV power systems to convert solar energy into electricity using non-reflective technology. All proposed improvements will be located on approximately 531 acres of land in south Imperial County, California.

1.2 SITE LOCATION AND DESCRIPTION

The proposed VEGA 4 Project is located approximately 11.5 miles east of Calexico and just north of the United States/Mexico border in Imperial County, California. The Project site consists of three parcels (Parcel Numbers 059-290-010, 059-300-015, and 059-300-017) and is bordered by the All American Canal to the north and United States/Mexico border to the south. The site location is shown on Figure 1, Site Location Map in Appendix A. Based on existing aerial data, the three parcels are unimproved with some minimal vegetation consisting of native small brush, cactus, and grass, to bare ground. Agricultural fields are located north of the All American Canal. A site reconnaissance was not completed for this project due to access restrictions.

The topography of the Project site is relatively flat with elevations ranging from approximately +33 feet at the west to +64 feet at the east. The coordinates at the center of the Project site are approximately:

Latitude: 32.68153°N

Longitude: 115.30894°W

1.3 PURPOSE AND SCOPE

The purpose of this preliminary geological and geotechnical study was to review existing geologic/geotechnical data and evaluate preliminary geological and geotechnical hazards for the proposed Project. This report is preliminary in scope and does not include a subsurface field investigation. A final design report must be performed prior to development after subsurface investigation and laboratory testing has been performed.

Our scope of services for this project included the following tasks:

Literature Review: Reviewed various readily available published and unpublished geologic and geotechnical documents pertinent to the Project site. A list of references used in preparation of this report is presented in Section 6.0.

Preliminary Geologic and Geotechnical Hazards Evaluation: This evaluation included location of known and mapped nearby earthquake faults and seismic zones in relation to the Project site, intensity of ground shaking, potential for liquefaction, ground rupture, landslides, and flooding. Other potential hazards such as expansion, collapse, and corrosivity potentials of on-site soils were also evaluated. Our evaluations were performed based on literature review only. Field and laboratory testing program was not included as a part of our services.

Report Preparation: Relevant geotechnical and geological data were compiled in this report along with our findings and conclusions for the proposed Project.

2.0 GEOLOGY, FAULTING AND SEISMICITY

2.1 REGIONAL GEOLOGIC SETTING

The Project site is located in the Imperial Valley, a part of the Salton Trough, located in the Colorado Desert physiographic province of California. With surface elevations as low as 275 feet below sea level, the Salton Trough formed as a structural depression resulting from tectonic boundary adjustment between the Pacific and the North American plates. The Salton Trough is bounded on the east and northeast by the San Andreas Fault and on the west by the San Jacinto Fault Zone. The structural trough is filled with more than 15,000 feet of Miocene and younger, marine and non-marine sediments capped by approximately 100 feet of Pleistocene and later lacustrine deposits that have been deposited by intermittent filling derived from periodic flooding of the Colorado River and Lake Cahuilla (Morton, 1977). A Regional Geologic Map is shown on Figure 2 (Appendix A).

2.2 SURFACE SUBGRADE SOILS AND GROUNDWATER CONDITIONS

Based on a review of published data by the California Geological Survey (CGS, 2010), the Project site is generally underlain by stratified alluvial deposits, predominately consisting of interbedded layers of silt, sand and clay. According to the Soil Survey of Imperial County prepared by United States Department of Agriculture Soil Conservation Service (2020), the near-surface soils are predominantly comprised of very fine to fine sand and occasionally clay and silty clay. The soil map for the Project site is shown on Figure 3.

A review of online water well databases from USGS (2021b) and California Department of Water Resources (2021) indicate that there are no known water wells within a mile radius from the site. Groundwater information should be obtained after conducting a subsurface field investigation during the design phase of the Project. Seasonal fluctuations of shallow groundwater should be expected during periods of rainfall, irrigation of adjacent properties, and site grading.

2.3 FAULTING

Southern California straddles the boundary between two global tectonic plates known as the North American Plate (on the east) and the Pacific Plate (on the west). The main plate boundary is represented by the San Andreas Fault, which extends northwest from the Gulf of California in Mexico, through the desert region of the Imperial Valley, through the San Bernardino region, and into Northern California, where it eventually trends offshore, north of San Francisco (Jennings and Bryant, 2010).

In Southern California, the plate boundary is a complex system of numerous faults known as the San Andreas Fault System (SAFS) that span a 150-mile-wide zone from the main San Andreas fault in the Imperial Valley westward to offshore of San Diego (Powell et al., 1993 and Wallace, 1990). The major faults east of San Diego (from east to west) include the San Andreas Fault, the San Jacinto fault, and the Elsinore fault. The SAFS is a transform plate boundary dominated by right-lateral fault displacement with the Pacific Plate moving northwest relative to the North American Plate (Wallace, 1990 and Weldon and Sieh, 1985). The significance of this lateral faulting is that transform plate interactions typically generate much smaller maximum magnitude earthquakes than convergent or subduction plate boundaries. Thus, in Southern California the expected maximum moment magnitudes for most faults are typically in the M6.5 to M7.5 range,

with only a few faults (San Andreas Fault, possibly some thrust faults of the Transverse Ranges) capable of generating earthquakes in the M8 range, such as the 1906 San Francisco and 1857 Fort Tejon earthquakes, on the San Andreas Fault itself.

Most of the seismic energy and associated fault displacement within the SAFS occurs along the fault structures closest to the plate boundary (i.e., on the Elsinore, San Jacinto, and San Andreas faults) (Powell et al. 1993). Approximately 1.9 inches/year (49 millimeters per year, [mm/yr.]) of overall lateral displacement have been measured geodetically and as fault slip across the plate boundary. Combined, the Elsinore, San Jacinto, and San Andreas faults account for up to 1.6 inches/year (41 mm/yr.), or 84 percent, of the total plate displacement. The remaining 16 percent is accommodated across the faults to the west (Bennett et al., 1996).

The Project site is located in the seismically active Southern California region, within the influence of several fault systems that are considered to be active or potentially active. Several active or potentially active faults are located in the vicinity of the Project site. The locations of these faults relative to the site are shown on Figure 4, Fault Map (Appendix A).

Under the current understanding of regional seismology and tectonics, the largest maximum earthquake to impact the project may be generated by the Imperial Fault having an estimated maximum magnitude of M7.3. Table 2-1 lists faults with a risk contribution greater than 1 percent, along with pertinent data such as fault type, distance to fault, and maximum magnitude. Other nearby faults are shown in Figure 4.

Table 2-1. Contributing Faults

Fault Name	Distance (km)	Site Location (Latitude and Longitude)	Maximum Magnitude
Imperial Fault [5]	3.8	32.68153°N 115.30894°W	7.3
Imperial Fault [6]	5.9		7.0
Imperial Fault [7]	10.4		6.9

Note:

Listed faults were derived from United States Geologic Survey (USGS) Deaggregation online tool and lists faults with a risk contribution greater than 1 percent of the total seismic risk. Site Class D was assumed and using USGS Dynamic 2014 dataset (V4.2.0) with a 2,475-year return period. See USGS (2021d) for details.

2.4 HISTORICAL SEISMICITY

The Project site and vicinity are located in an area characterized by high seismicity.

The seismicity of the region surrounding the project site was evaluated using the earthquake database from USGS website (2021c). Based on the review of the available data, 206 earthquake events with magnitudes equal or greater than 4.5 have occurred within a radius of 60 miles of the site in the last 100 years. Selected location of the earthquake epicenter, year of occurrence, and earthquake magnitude are summarized in Table 2-2. The earthquakes listed below are based on largest magnitudes.

Table 2-2. List of Selected Historic Earthquakes

Earthquake Location	Date of Earthquake	Earthquake Magnitude
12 km SW of Delta, B.C., MX	04-04-2010	7.2
4 km N of Holtville, CA	05-19-1940	6.9
22 km W of Westmorland, CA	11-24-1987	6.6
5 km NNE of Ocotillo Wells, CA	04-09-1968	6.6
17 km WSW of Westmorland, CA	10-21-1942	6.6
5 km S of Alberto Ovidio Mota, B.C., MX	12-31-1934	6.4
10 km E of Mexicali, B.C., MX	10-15-1979	6.4
24 km SSE of Estacion Coahuila, B.C., MX	12-30-1934	6.3

3.0 ASSESSMENT OF POTENTIAL GEOLOGIC AND GEOTECHNICAL HAZARDS

3.1 SEISMIC SHAKING

The Project site is located in the highly seismic Southern California region within the influence of several fault systems that are considered to be active or potentially active. A list of known faults considered capable of producing potentially damaging seismic shaking at the site is presented in Table 2-1. It is anticipated that the Project site will periodically experience ground accelerations and shaking as the result of small to moderate magnitude earthquakes occurring along these faults and other faults within the Southern California region.

The results of our preliminary seismic hazard analyses indicated that the estimated horizontal peak ground acceleration (PGA) having a 2 percent probability of exceedance in 50 years and corresponding to the statistical return period of approximately 2,475 years, which is defined as the Maximum Considered Earthquake (MCE), is on the order of 0.97g.

3.2 FAULT-RUPTURE HAZARD

Surface rupture usually occurs along traces of known active or potentially active faults. However, many historic seismic events, including the 1994 Northridge Earthquake, have occurred on faults without surface expression (blind faults) that were not previously known to exist or to be active.

The California Geologic Survey (CGS) established criteria for faults as active, potentially active, and inactive. Active faults are those that show evidence of surface displacement within the last 11,000 years (Holocene age). Potentially active faults are those that demonstrate displacement within the past 1.6 million years (Quaternary age). Faults showing no evidence of displacement within the last 1.6 million years may be, in general, considered inactive for most structures, except for critical structures. In 1972 the Alquist-Priolo Special Studies Earthquake Hazards Act (APEHA) was passed, which required fault studies within 500 feet of active or potentially active faults. The APEHA designates “active” and “potentially active” faults utilizing the same age criteria as that used by the CGS. The site is not located within a currently-delineated State of California Alquist-Priolo Earthquake Fault Zone (Bryant and Hart, 2007 and CGS, 2019) and therefore the likelihood of fault rupture at the Project site is considered low. Location of known Alquist Priolo Earthquake Fault Zones in the general vicinity of the Project Site is shown on Figure 5, Seismic Hazard Map (Appendix A).

3.3 FLOOD HAZARD AND TSUNAMIS

Flooding can occur as a result of several factors in developed areas. These factors include: rainfall rates that exceed an area’s ability to absorb or control the runoff; impounded water retained behind a flood control structure (upstream-inundation), failure of a flood control structure (downstream-inundation), seiches, and tsunami.

According to the Federal Emergency Management Agency (FEMA) Flood Insurance Rate Map Number 06025C2125C (2008), the Project site is considered a Zone X site, which is an area that is determined to be outside the 0.2% annual chance of flooding. Therefore, the risk related to natural flooding is low.

Due to the site's inland location and the lack of any local impounded bodies of water, tsunamis, and seiches do not represent potential hazards to the site.

3.4 LANDSLIDING

Landslides and other forms of mass wasting, including mud flows, debris flows, and soil slips occur as soil moves downslope under the influence of gravity. Landslides are frequently triggered by intense rainfall or seismic shaking. Because the site is located in a relatively flat area, we do not consider landslides or other forms of natural slope instability to represent a significant hazard to the project.

3.5 LIQUEFACTION/SEISMIC SETTLEMENT

The term liquefaction describes a phenomenon in which saturated, cohesionless soils temporarily lose shear strength (liquefy) when subjected to cyclic ground motions. Cyclic loading of saturated soils leads to the build-up of pore water pressure as a result of soil particles being rearranged with a tendency toward closer packing. Under undrained conditions, shaking of loose non-cohesive soils may result in loads being transferred from the soil skeleton to the pore water with consequent reduction in the soil strength and stiffness. Structures founded on or above potentially liquefiable soils may experience bearing capacity failures due to the temporary loss of foundation support, vertical settlements (both total and differential), and/or undergo lateral spreading. The factors known to influence liquefaction potential include soil type, relative density, grain size distribution, confining pressure, depth to groundwater, and the intensity and duration of the seismic ground shaking. Liquefaction is most prevalent in loose- to medium-dense, silty, sandy, and gravelly soils below the groundwater table.

The Project site has not been mapped for liquefaction potential by CGS. Due to the limited soils and groundwater information, the liquefaction potential at the project site cannot be determined. The liquefaction potential should be further evaluated during the design phase of the Project, using site-specific information collected from future site-specific exploratory boreholes.

3.6 LATERAL SPREADING

Liquefaction-induced lateral spreading is defined as the lateral displacement of ground as a result of pore pressure build-up or liquefaction in shallow underlying soils during an earthquake. Lateral spreading can occur on sloping ground or where nearby slopes are present. The factors known to influence the magnitude of lateral spreading include earthquake magnitude, peak ground acceleration, distance between the site and the seismic event, the slope height and gradient, thickness of the liquefied layer, fines content, soil particle gradation, and residual strength of the liquefied soil.

A site-specific geotechnical investigation should be performed and mitigation measures, if necessary, should be developed to reduce the magnitude of lateral displacement due to lateral spreading.

3.7 LAND SUBSIDENCE

Subsidence is the sinking of the ground surface caused by the compression of earth materials or the loss of subsurface soil due to underground mining, tunneling, or erosion. The major causes of subsidence include fluid withdrawal from the ground, decomposing organics, underground

mining or tunneling, and placing large fills over compressible earth materials. The effective stress on underlying soils is increased resulting in consolidation and settlement. Subsidence may also be caused by tectonic processes. The Project site is not located in an area of known ground subsidence or within any delineated zones of subsidence due to groundwater pumping or oil extraction (USGS, 2021a). Accordingly, the potential for subsidence to occur at the site is considered to be low.

3.8 EXPANSIVE SOILS

Expansive soils are characterized by their ability to undergo significant volume changes (shrink or swell) due to variations in moisture content. Changes in soil moisture content can result from precipitation, landscape irrigation, utility leakage, roof drainage, perched groundwater, drought, or other factors and may result in unacceptable settlement or heave of structures. Based on available data, the onsite near-surface soil deposits primarily consist of sand, gravelly sand and clay/silty clay. Generally, sands are considered not expansive soils and clays may exhibit moderate to high expansion potential due to variation in moisture content. A site-specific geotechnical investigation should be performed to evaluate soil expansiveness and potential impact, if any, of expansive soil on the Project.

3.9 COLLAPSIBLE SOILS

Collapsible soil is generally defined as soil that will undergo a sudden decrease in volume and its internal support is lost under applied loads when water is introduced into the soil. The internal support is considered to be a temporary strength and is derived from a number of sources including capillary tension, cementing agents, e.g. iron oxide and calcium carbonate, clay-welding of grains, silt bonds, clay bonds and clay bridges. Soils found to be most susceptible to collapse include loess (fine grained wind-deposited soils), valley alluvium deposited within a semi-arid to arid climate, and residual soil deposits. At this time, it is unknown whether collapsible soils are present at the site. A site-specific geotechnical investigation should be performed to assess the presence of collapsible soils and evaluate potential impact, if any, of collapsible soils on the proposed improvements.

3.10 SOIL CORROSION

A site-specific corrosion study should be performed and mitigation measures should be recommended if the soils are found to be corrosive to concrete or steel. Generally, fine grained soils like clay are more likely to be corrosive. Typical remediation for the corrosive soil conditions consists of using concrete mix with higher cement contents (Type V Portland Cement) and appropriate steel corrosion protection. Because fine grained soils are expected to be encountered at the subject site, corrosion potential should be further evaluated during the design phase of this Project.

3.11 OTHER GEOLOGIC HAZARDS

Volcanic Eruption: The Project site is not located in an area of a recent volcanism. Therefore, the potential for volcanic activity is very low.

Radon Gas: Radon gas is a radioactive product of uranium which can reach high levels depending on the local geology and building construction. According to Environmental Protection

3.0 Assessment of Potential Geologic and Geotechnical Hazards

Agency (EPA) Map of Radon Zones, the Project site, as the entire Imperial County, is located in Zone 3 with predicted average indoor radon screening levels less than 2 picocuries per liter (pCi/L). Since the site is not located within an area of high potential for indoor radon levels (above 4 pCi/L), the potential for radon gas accumulation is considered low.

Naturally Occurring Asbestos: The site is not located in an area of known naturally occurring asbestos (CGS, 2011). Therefore, the potential for occurring asbestos is considered low.

Hazardous Materials: The site is not located in proximity to any known hazardous materials (methane gas, hydrogen sulfide gas) and the risk of hazardous materials is considered low.

4.0 PRELIMINARY SEISMIC DESIGN RECOMMENDATIONS

To reduce the effects of ground shaking produced by regional seismic events, seismic design should be performed in accordance with the applicable building codes. Preliminary seismic parameters were calculated using the California’s Office of Statewide Health Planning and Development [OSHPD] (2018) and in accordance with the 2016 California Building Code and the American Society of Civil Engineers/Structural Engineering Institute (ASCE/SEI) (2017) 7-16. Site Class D was assumed for preliminary design and must be confirmed prior to final design. Seismic design parameters for Site Class D are provided in Table 4-1.

Table 4-1. Preliminary Seismic Design Parameters

Category	Recommended Value
Risk Category	II ⁽¹⁾
Site Class	D
Latitude	32.68153°N
Longitude	115.30894°W
Mapped (5% damped) spectral response acceleration parameter at short period (0.2 sec), S_s	1.952
Mapped (5% damped) spectral response acceleration parameter at long period (1.0 sec), S_1	0.683
Short period (0.2 sec) site coefficient, F_a	1.0
Long period (1.0 sec) site coefficient, F_v	1.7
Spectral response acceleration parameter at short period (0.2 sec), S_{MS}	1.952
Spectral response acceleration parameter at long period (1.0 sec), S_{M1}	1.161
Design (5% damped) spectral response acceleration parameter at short period (0.2 sec), S_{DS}	1.302
Design (5% damped) spectral response acceleration parameter at long period (1.0 sec) S_{D1}	0.774 ⁽²⁾
Peak Ground Acceleration (PGA) (g)	0.805
Site -adjusted PGA ($PGAM$) (g)	0.966
Design Magnitude ⁽³⁾ Mw	7.1

Notes:

- (1) Risk category was assumed and should be verified by designer during final design.
- (2) See the commentary in ASCE/SEI 7-16, Section 11.4.8 for site-specific ground motion analysis and “Exception note” 2.
- (3) Design magnitude based on USGS Probabilistic Deaggregation with 2% chance of exceedance in 50 years (2,475 year return interval) (USGS, 2021c).

5.0 CONCLUSIONS AND LIMITATIONS

Our review of available geological and geotechnical literature did not reveal conditions that would preclude development of the proposed Project provided, as mentioned above, a site-specific geotechnical investigation is conducted prior to the site development. The proposed project is considered feasible for development from a geotechnical perspective.

This preliminary geological and geotechnical hazard evaluation report has been prepared for the use of HDR and Imperial County for the proposed VEGA 4 Project. The report may not be used by others without the written consent of our client and our firm. The findings, conclusions, and preliminary recommendations presented in this report were prepared in a manner consistent with the standard of care and skill ordinarily exercised by members of its profession, practicing under similar conditions in the geographic vicinity, and at the time the services were performed. No other warranty is either expressed or implied.

Our findings, conclusions and preliminary recommendations presented in this report may be used for preliminary consideration of the feasibility and cost of site development purposes only. They are not intended for the design of the project. Additionally, a site-specific geotechnical investigation should be performed during the planning process for the proposed Project, in order to develop recommendations for the specific foundation designs and earthwork construction being considered for this project.

We appreciate the opportunity to provide our services on this Project. Please do not hesitate to contact undersigned if you have questions, comments, or need additional information.

Respectfully submitted,

HDR Engineering, Inc.

Manuel Guzman, PE
Engineer - Geotechnical

Gary Goldman, PE, GE
Senior Project Manager-Geotechnical

6.0 REFERENCES

The following references were used in preparation of this report:

Bennett et al, 1996, Global Positioning System Constraints on Fault Slip Rates in Southern California and Northern Baja, Mexico, *Journal of Geophysical Research*, Volume 101, Issue B10, October 10.

Bryant, W.A. and Hart, E.W., 2007, Fault-Rupture Hazard Zones in California, *Alquist-Priolo Earthquake Fault Zoning Act with Index to Earthquake Fault Zones Maps: California Geological Survey Special Publication 42*, 42p.

California Building Code, 2016.

California Department of Water Resources, 2021, Water Data Library, <https://groundwaterwatch.usgs.gov/>, accessed January 2021.

California Geological Survey (CGS), 2010, Geologic Map of California.

CGS, 2011, Reported Historic Asbestos Mines, Historic Asbestos Prospects, and other Natural Occurrences of Asbestos in California, Open File Report 2011-1188, California Geological Survey Map Sheet 59.

CGS, 2019, California Earthquake Hazards Zone Application (EQ Zapp, updated April 4), from <<https://www.conservation.ca.gov/cgs/geohazards/eq-zapp>> website, accessed January 2021.

California's Office of Statewide Health Planning and Development (OSHPD), 2018, Seismic Design Maps Online Tool, Accessed January 2021, <https://seismicmaps.org/>.

Environmental Protection Agency (EPA, 1993), EPA 1993 National Radon Zone Map at: <https://www.cdph.ca.gov/Programs/CEH/DRSEM/Pages/EMB/Radon/Radon-in-California.aspx#>

Federal Emergency Management Agency (FEMA), 2008, Flood Insurance Rate Maps, FEMA Map No. 06025C2125C, available at: <https://msc.fema.gov/portal/search>

Jennings, C.W., and Bryant, W.A., 2010, Fault Activity Map of California, California Geologic Data Map No. 6.

Morton, P., 1997, Geology and Mineral Resources of Imperial County, California, County Report 7

Powell, R.E., Weldon, R.J., and Matti, J.C., 1993, The San Andreas Fault System: Displacement, Palinspastic Reconstruction, and Geologic Evolution, Geological Society of America, Memoir 178, 376 p.

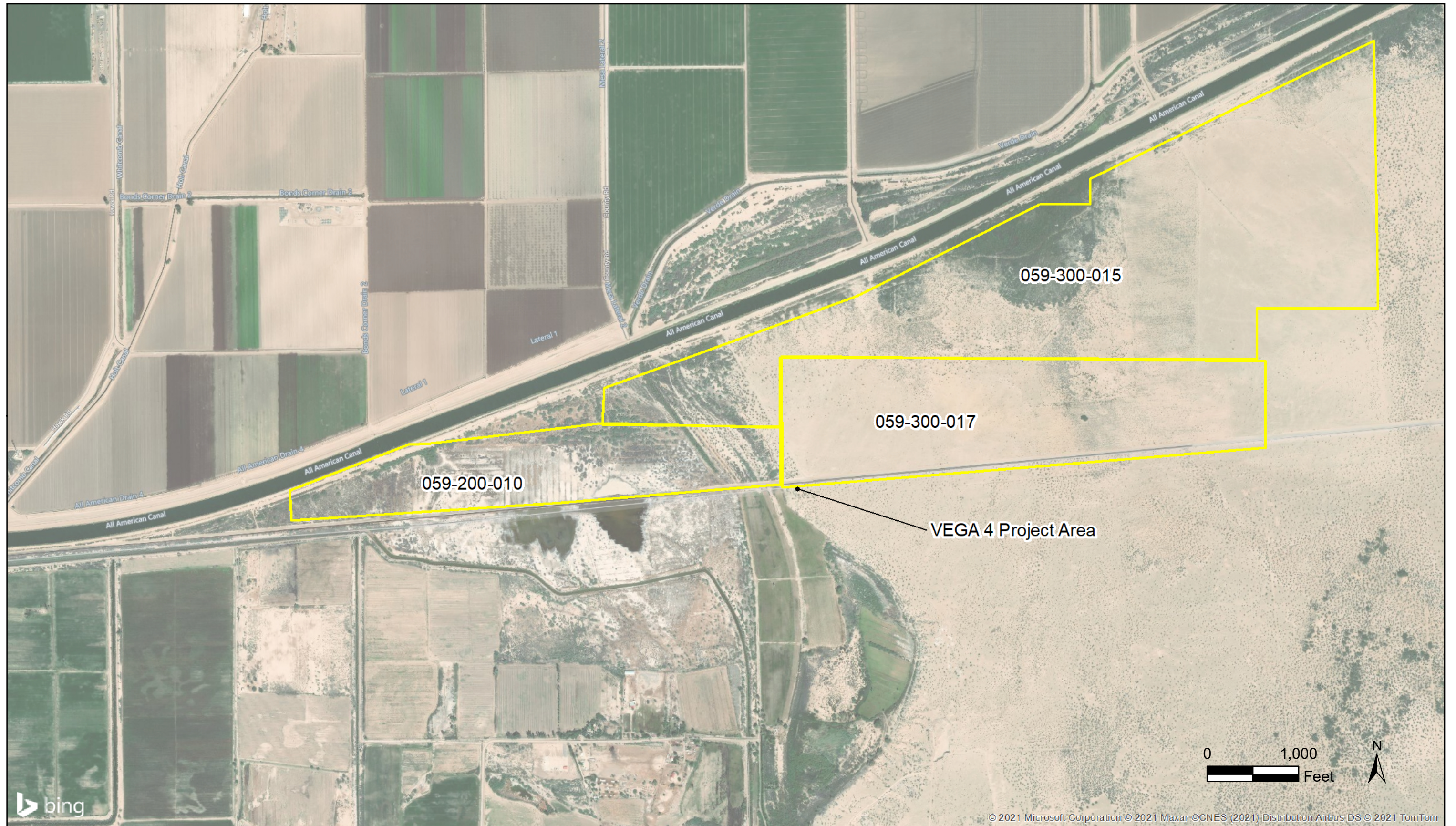
6.0 References

- Wallace, R.E. 1990, The San Andreas Fault System, California, U.S. Geological Survey Professional Paper 1515, pp. 3-12.
- Weldon, R.J., and Sieh, K.E., 1985, Holocene Rate of Slip and tentative Recurrence Interval for Large Earthquakes on the San Andreas Fault, Cajon Pass, Southern California, Geological Society of America Bulletin 96.
- United States Department of Agriculture Soil Conservation Service (2020); available at: <https://websoilsurvey.sc.egov.usda.gov/App/HomePage.htm>.
- USGS, 2006, U.S. Quaternary Fault and Fold Database, <https://usgs.maps.arcgis.com/apps/webappviewer/index.html?id=5a6038b3a1684561a9b0aadf88412fcf>.
- USGS, 2021a, Areas of Land Subsidence in California, https://ca.water.usgs.gov/land_subsidence/california-subsidence-areas.html, accessed January 2021.
- USGS, 2021b, Groundwater Watch, <https://groundwaterwatch.usgs.gov/>, accessed January 2021.
- USGS, 2021c, Search Earthquake Catalog, <https://earthquake.usgs.gov/earthquakes/search/>, Accessed January 2021.
- USGS, 2021d, Unified Hazard Tool, available at: <https://earthquake.usgs.gov/hazards/interactive/>.

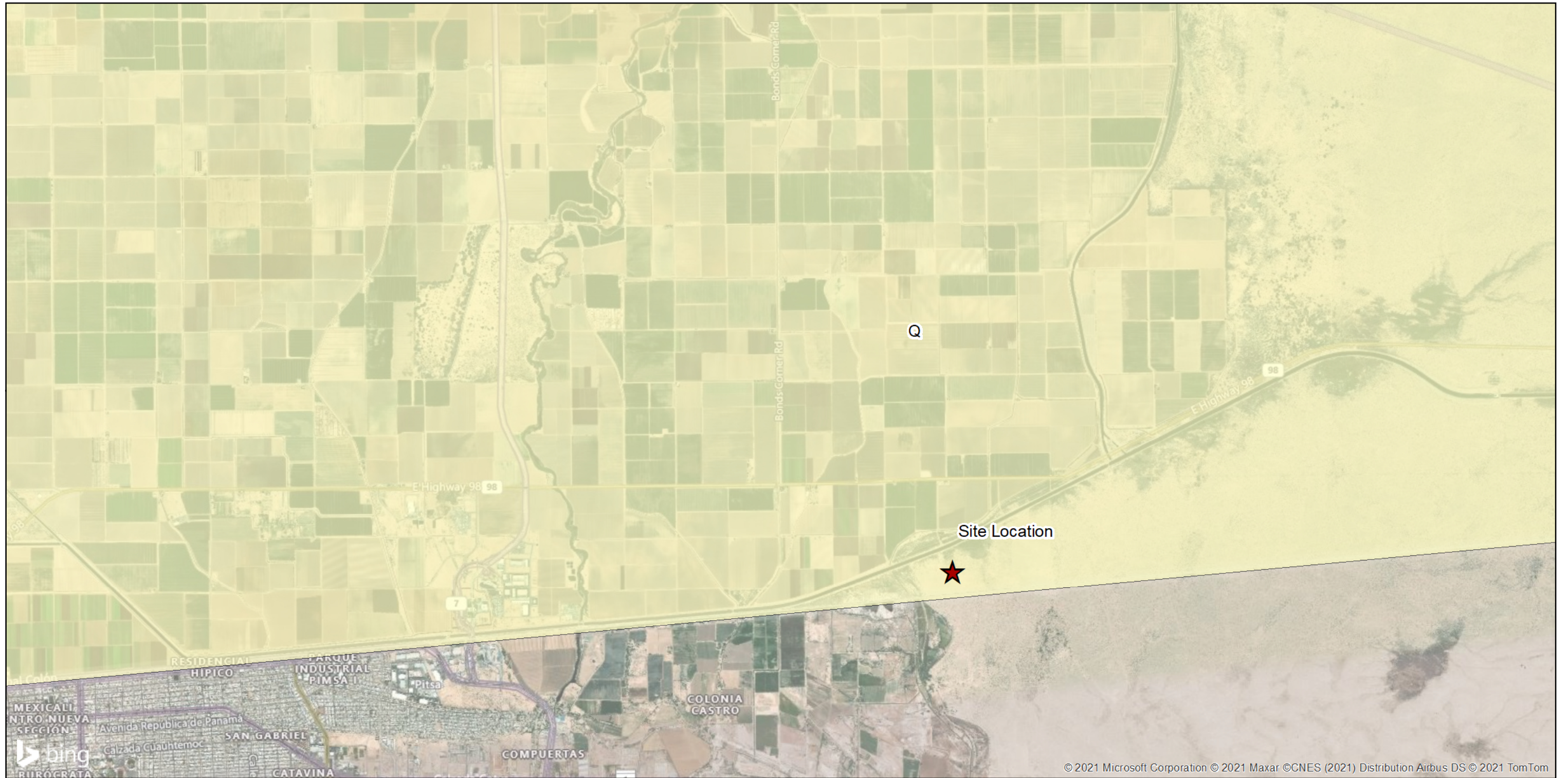
Appendix A

Figures



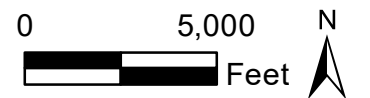


SOIL LOCATION MAP
VEGA 4
IMPERIAL COUNTY, CALIFORNIA
PC ORIGINAL PKG

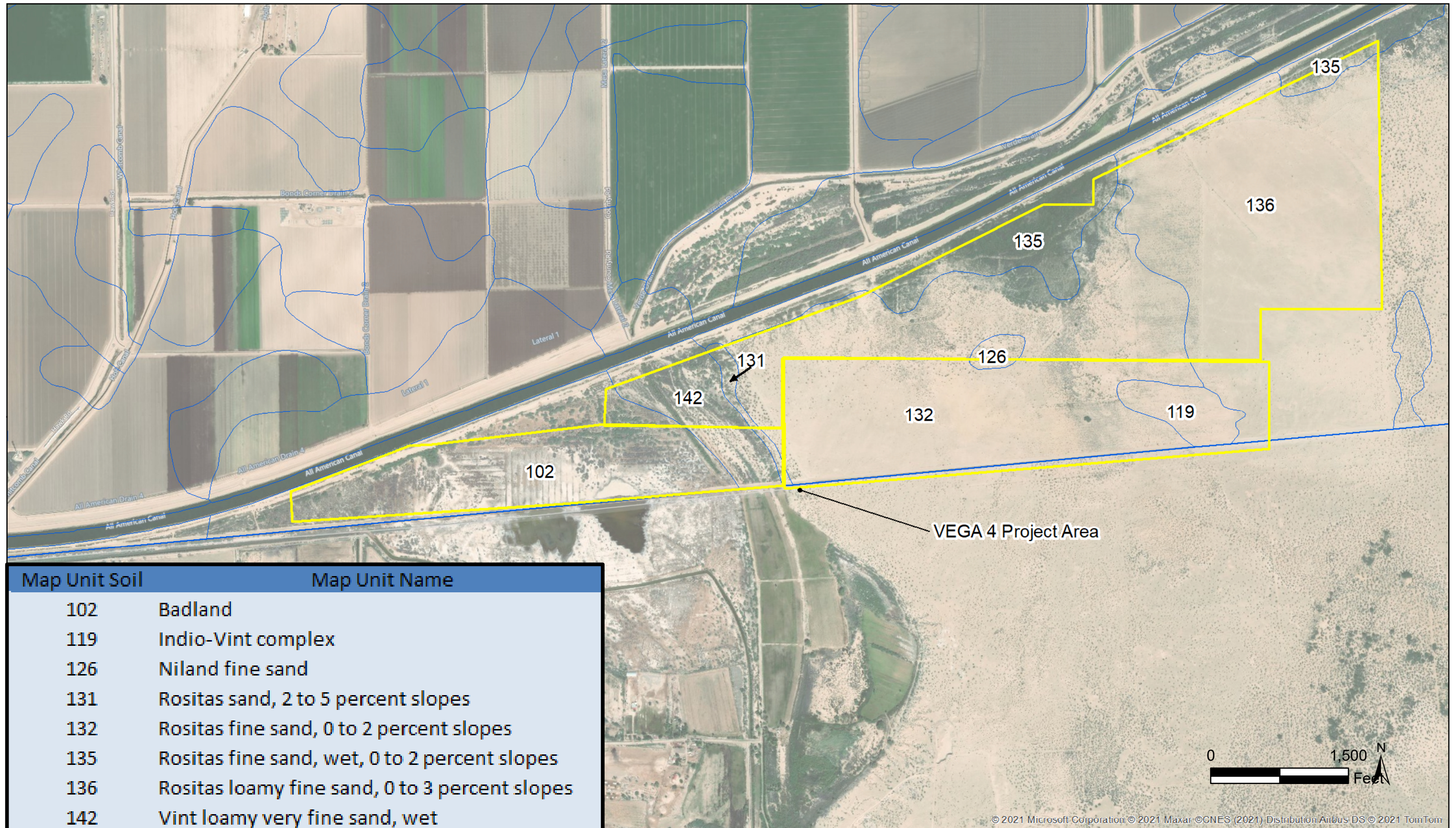


Reference: CGS, 2010, Geologic Map of California, Original compilation by Charles W. Jennings, Updated version by Carlos Gutierrez, William Bryant, George Saucedo, and Chris Wills.

Q - Alluvium, lake, playa, and terrace deposits; unconsolidated and semi-consolidated. Mostly nonmarine, but includes marine deposits near the coast.



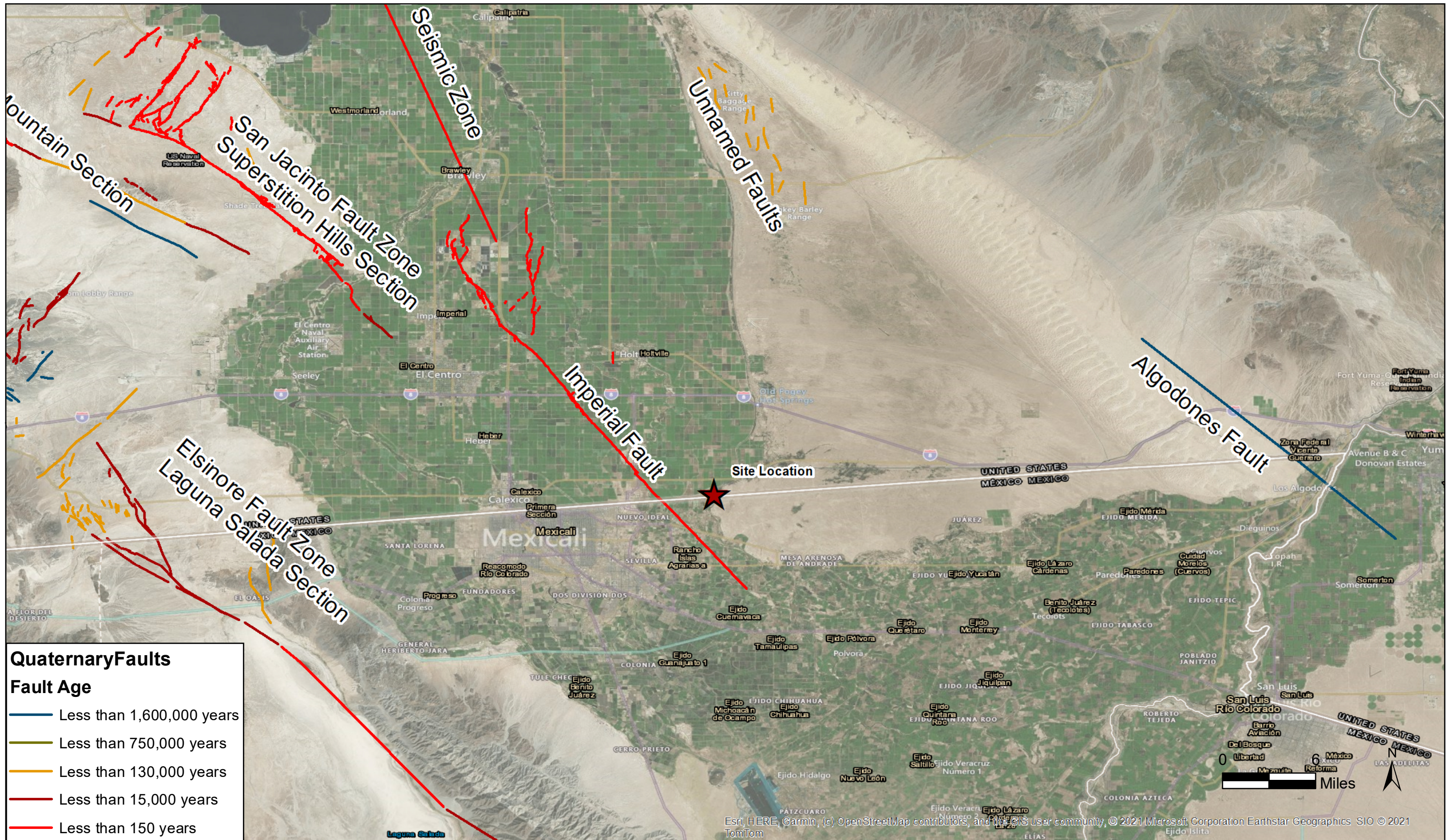
**REGIONAL GEOLOGIC MAP
VEGA 4
IMPERIAL COUNTY, CALIFORNIA
PC ORIGINAL PKG**



© 2021 Microsoft Corporation © 2021 Maxar © CNES (2021) Distribution Airbus DS © 2021 TomTom

Reference: USDA, 2020, Web Soil Survey

SOIL SURVEY MAP
 VEGA 4
 IMPERIAL COUNTY, CALIFORNIA
 PC ORIGINAL PKG



Quaternary Faults
Fault Age

- Less than 1,600,000 years
- Less than 750,000 years
- Less than 130,000 years
- Less than 15,000 years
- Less than 150 years

* Fault Age classifications are based on geologic evidence to determine the youngest faulted unit and the oldest unfaulted unit along each fault or fault section (Jennings, C.W., and Bryant, W.A., 2010)

Reference: USGS, 2006

FAULT MAP
VEGA 4
IMPERIAL COUNTY, CALIFORNIA
PC ORIGINAL PKG



Reference: CGS, 2019

**SEISMIC HAZARD MAP
VEGA 4
IMPERIAL COUNTY, CALIFORNIA
PC ORIGINAL PKG**

Phase I ESA Report

Vega 4 (Doyle Ranch) Solar Site South side of the AAC at Bonesteele Road Holtville, California

Prepared for:

Vega SES 4, LLC
750 Main Street
El Centro, CA 92243



Prepared by:



GS Lyon Consultants, Inc.
780 N. 4th Street
El Centro, CA 92243
(760) 337-1100

December 2020

PC ORIGINAL PKG



Engineering And
Information Technology

December 17, 2020

Mr. Ziad Alaynon
Vega SES 4, LLC
750 Main Street
El Centro, CA 92243

**Phase I Environmental Site Assessment Report
Vega 4 (Doyle Ranch) Solar Site
Holtville, California
*GSL Report No. GS2015***

Dear Mr. Alaynon:

We have performed a Phase I Environmental Site Assessment in general conformance with the scope and limitations of ASTM E1527-13 of the approximately 530-acre property located on the south side of the All American Canal at Bonesteele Road approximately 10 miles south of Holtville, California. Any exceptions to, or deletions from, this practice are described in Section 1.4 of this report. **This assessment has revealed the following “de minimis” conditions in connection with the property:**

- Pesticide residues (low concentrations) typical to agricultural crop applications are present in the near surface soils.
- Pole-mounted sealed electrical transformers owned and maintained by the Imperial Irrigation District (IID) exist on this subject property. All IID transformers containing PCB's have been replaced. ***If the transformers begin to leak, the IID should be notified and the transformers replaced.***

This assessment has not revealed any recognized environmental conditions (REC's) in connection with the property.

We declare that, to the best of our professional knowledge and belief, we meet the definition of *Environmental Professional* as defined in §312.10 of 40 CFR §312 and we have the specific qualifications based on education, training and experience to assess a property of the nature, history, and setting of the subject property. We have developed and performed all the appropriate inquiries in conformance with the standards and practices set forth in 40 CFR Part 312.

PC ORIGINAL PKG

Attached is our report which describes the procedures used and results of the assessment. If you have any questions or require additional information, please do not hesitate to contact the undersigned at (760) 337-1100. We appreciate the opportunity to provide our professional review for this subject property.

Respectfully Submitted,
GS Lyon Consultants, Inc.



Jeffrey O. Lyon, PE
Principal Engineer



Steven K. Williams, PG, CEG
Consulting Geologist



TABLE OF CONTENTS

1.0 INTRODUCTION 1

 1.1 Purpose 1

 1.2 Scope of Services 1

 1.3 Limitations 2

 1.4 Deviations or Data Gaps 2

 1.4.1 Data Failures 3

 1.4.2 Data Gaps..... 3

 1.5 Significant Assumptions 3

 1.6 User Reliance 4

2.0 SITE DESCRIPTION 5

 2.1 Site Location and Legal Description 5

 2.2 Current Property Use and Description 5

 2.3 Adjoining Property Use..... 5

 2.4 Physical Site Characteristics 5

3.0 USER PROVIDED INFORMATION 7

 3.1 Title Records 7

 3.2 Environmental Liens or Activity and Use Limitations 7

 3.3 Specialized Knowledge 8

 3.4 Commonly Known or Reasonable Ascertainable Information 8

 3.5 Valuation Reduction for Environmental Issues 8

 3.6 Owner, Property Manager, and Occupant Information..... 8

 3.7 Previous Reports and Other Provided Documentation 8

4.0 RECORDS REVIEW..... 9

 4.1 Regulatory Database Review 9

 4.1.1 Standard Environmental Record Sources 9

 4.1.2 Additional Environmental Record Sources 13

 4.2 Historical Use Records..... 14

 4.2.1 Title Records..... 14

 4.2.2 Sanborn Fire Insurance Maps 15

 4.2.3 Aerial Photographs..... 15

 4.2.4 Street Directories 16

 4.2.5 Historic Topographic Maps 16

 4.2.6 Historical Telephone Directories 16

 4.3 Historical Use Summary 16

 4.3.1 Summary of the Historical Use of Property..... 16

 4.3.2 Summary of the Historical Use of Adjacent Properties..... 16

5.0 SITE RECONNAISSANCE 17

 5.1 Methodology and Limiting Conditions 17

 5.2 General Site Setting..... 17

 5.3 Adjacent Properties 18

 5.4 Exterior and Interior Observations 18

 5.4.1 Hazardous Substances and Petroleum Products 18

 5.4.2 Storage Tanks..... 18

 5.4.3 Odors..... 18

5.4.4 Pools of Liquid..... 18

5.4.5 Drums and Containers..... 19

5.4.6 Unidentified Substance Containers..... 19

5.4.7 Suspect Polychlorinated Biphenyl (PCB) Containing Equipment..... 19

5.5 Interior Observations..... 19

5.6 Exterior Observations..... 19

5.6.1 Pits, Ponds, and Lagoons 19

5.6.2 Stained Soils or Pavement 19

5.6.3 Stressed Vegetation..... 19

5.6.4 Solid Waste 19

5.6.5 Wastewater..... 19

5.6.6 Wells 20

5.6.7 Septic Systems 20

5.7 Non-Scope Issues 20

5.7.1 Asbestos-Containing Building Materials..... 20

5.7.2 Lead-Based Paint 20

5.7.3 Radon 20

5.7.4 Agricultural Use..... 20

6.0 INTERVIEWS 21

6.1 Interview with Owner..... 21

6.2 Interview with the Site Manager 21

6.3 Interview with Occupants..... 21

6.4 Interview with Local Government Officials 21

7.0 EVALUATION..... 22

7.1 Summary of Findings..... 22

7.2 Conclusions 22

7.2.1 Recognized Environmental Conditions 22

7.2.2 Historical Recognized Environmental Conditions..... 23

7.2.3 Environmental Concerns and De Minimis Conditions 23

7.3 Recommendations 23

8.0 REFERENCES 24

APPENDICES

- Appendix A: Site Photographs
- Appendix B: Vicinity, Site, and Soils Maps
- Appendix C: Historical Aerial Photographs
- Appendix D: Historical Topographic Maps
- Appendix E: EDR Environmental Records Search Report
- Appendix F: Other Environmental Records Search Results
- Appendix G: Preliminary Title Report
- Appendix H: User Questionnaire and EDR Environmental Lien and AUL Search
- Appendix I: Resumes of Environmental Professionals

1.0 INTRODUCTION

1.1 Purpose

GS Lyon Consultants, Inc. was retained by Vega SES 4, LLC to conduct a Phase I Environmental Site Assessment (ESA) for the Property (herein referred to as the subject property or subject site in this Phase I ESA Report) as a prerequisite to property transaction (purchase, sale, refinance, etc.). The approximately 530-acre subject property is located on the south side of the All American Canal at Bonesteele Road approximately 10 miles south of Holtville, California. See Plate 1 in Appendix B for a Vicinity Map of the subject property.

The purpose of this Phase I Environmental Site Assessment (ESA) is to identify, to the extent feasible, recognized environmental conditions (RECs) associated with past and present activities on the subject property or in the immediate subject property vicinity in general conformance to ASTM Standard E1527-13 “*Standard Practice for Environmental Site Assessments: Phase I Environmental Site Assessment Process*” that may affect future uses of the subject property.

This report is intended to satisfy the Phase I ESA portion of “*all appropriate inquiry*” into the previous ownership and uses of the subject property as defined under the Comprehensive Environmental Response, Compensation, and Liability Act (CERCLA) at Title 42 of the United States Code (U.S.C.) §9601(35)(B) and in accordance with 40 Code of Federal Regulations (CFR) Part 312, Standards and Practices for All Appropriate Inquiries; Final Rule (AAI Rule).

1.2 Scope of Services

The scope of work for this ESA is in general accordance with the requirements of ASTM Standard E1527-13. This assessment included:

- Reconnaissance of the subject property and adjacent properties
- Review user-provided information
- Interviews with persons with significant knowledge of the subject property
- Review of a regulatory database report provided by a third-party vendor
- Review readily-available historical sources (including but not limited to: aerial photographs, fire insurance maps, property tax files, recorded land title records, and topographical maps)
- Prepare report of findings

1.3 Limitations

No Phase I ESA can completely eliminate uncertainty regarding the potential for RECs in connection with a property. Conformance of this assessment with ASTM Standard E1527-13 is intended to reduce, but not eliminate uncertainty regarding the potential for RECs in connection with the Subject Property. While GS Lyon has made reasonable effort to discover and interpret available historical and current information on the property within the time available, the possibility of undiscovered contamination remains. Our assessment of the subject property and surrounding areas was conducted in accordance with ASTM guidelines and the *generally accepted environmental engineering standard of practice* which existed in Imperial County, California at the time that the report was prepared. No warranty, express or implied, is made.

GS Lyon Consultants, Inc. derived the data in this report primarily from visual inspections, examination of public records and information in the public domain, informal interviews with individuals, and readily available information about the subject property. The passage of time, manifestation of latent conditions or occurrence of future events may require further exploration of the subject property, analysis of the data, and reevaluation of the findings, observations, and conclusions expressed in this report.

The findings, observations, and conclusions expressed by GS Lyon Consultants in this report are not, and should not be considered, an opinion concerning the compliance of any past or present owner or operator of the subject property with any federal, state or local law or regulation.

This report should not be relied upon after **180 days** from the date of issuance, unless additional services are performed as defined in ASTM E1527-13 - Section 4.7.

1.4 Deviations or Data Gaps

ASTM Standard E1527-13 requires any significant data gaps, deviations, and deletions from the ASTM Standard to be identified and addressed in the Phase I ESA. A significant data gap would be one that affected the ability to identify a REC on the subject property or adjacent properties.

Through the course of this assessment, *data failures* or *data gaps* may have been encountered. These failures or gaps, if any, are discussed below. The following provides the opinion of the Environmental Professional as to the significance of the data gaps in terms of defining *recognized environmental conditions* at the subject property. Data failures may or may not be significant data gaps, and the discussion also provides information pertaining to whether the data failures resulted in significant data gaps.

1.4.1 Data Failures

Data failure is a failure to achieve the historical (property use) research objectives specified in the ASTM Standard Practice even after reviewing the eight standard historical sources that are reasonably ascertainable and likely to be useful. Data failure is one type of data gap. No *data failures* were encountered during this investigation.

1.4.2 Data Gaps

A *data gap* is a lack of or inability to obtain information required by the ASTM Standard Practice, despite good faith efforts by the Environmental Professional to gather such information. This could include any component of the Practice, e.g., standard environmental records, interviews, or a complete reconnaissance. A data gap by itself is not inherently significant, but if other information and/or the EP's experience raises reasonable concerns about the gap, it may be judged to be significant.

Due to the location of the subject property, Sanborn Fire Insurance maps were not available for the subject property. Because there is no historical data or physical indications that the property has ever been developed or occupied by a business that would have produced hazardous materials, the lack of Sanborn Fire Insurance maps is not considered a significant data gap.

Aerial photographs and other historical records were not available at 5 year intervals as required under the ASTM E1527-13 standard. This resulted in a data gap for years that records were not available regarding the area of the subject property. However, based upon other historical information reviewed, the subject property has been vacant desert land up to about 1980 when a portion of the subject property was converted into agricultural use. Therefore, this data gap is not considered to be significant.

Interviews with past owners, operators and occupants were not reasonably ascertainable and thus constitute a data gap. Based on information obtained from other historical sources (as discussed in Section 3.0), this data gap is not expected to alter the findings of this assessment.

1.5 Significant Assumptions

In preparing this report, GS Lyon Consultants, Inc. has relied upon and presumed accurate certain information (or the absence thereof) about the subject property and adjacent properties by governmental officials and agencies, the Client, and others identified herein. Except as otherwise stated in the report, GS Lyon Consultants has not attempted to verify the accuracy or completeness of any such information.

1.6 User Reliance

This report has been prepared on behalf of and for the exclusive use of Vega SES 4, LLC for the particular subject property identified in this report, and is subject to and issued in connection with the referenced Agreement and the provisions thereof. This report should not be relied upon by any party other than the client, its legal counsel, and financial institution without the express permission of GS Lyon Consultants, Inc. Any reliance on this report by other parties shall be at such party's sole risk. Any future consultation or provision of services to third parties related to the subject property requires written authorization from Vega SES 4, LLC or their representatives. Any such services may be provided at GS Lyon Consultants sole discretion and under terms and conditions acceptable to GS Lyon Consultants, including potential additional compensation.

2.0 SITE DESCRIPTION

2.1 Site Location and Legal Description

The approximately 530-acre subject property (APNs 059-299-010, 059-300-017, and 059-300-015) is located on the south side of the All American Canal at Bonesteele Road approximately 10 miles south of Holtville, California. The subject property location is depicted on Plate 1, Site Map.

2.2 Current Property Use and Description

The subject property currently consists of approximately 530 acres comprised of three parcels (APNs 059-299-010, 059-300-017, and 059-300-015). The subject property is roughly triangular in plan view with the All American Canal forming the northern boundary, the International Border with the Republic of Mexico forming the southern boundary and vacant desert land forming the eastern boundary. The majority of the subject site has been cleared of desert vegetation for agricultural use. The western wedge and a small area in the north-central portion of the site are heavily vegetated where shallow groundwater has accumulated due to seepage from the earthen All American Canal.

A farm yard is located in the north-central portion of the subject site. A small masonry building housing water pumps, an above ground fuel storage tank (AST) and a storage building, all located within a chain-link fenced area comprise the farm yard. A bank of pole mounted transformers is located on the embankment of the All American Canal adjacent to the farm yard. A small equipment storage area with a disc, a trap wagon, and other miscellaneous farm implements is located northeast of the farm yard area. There are two central-pivot sprinklers that are located in the central portion of the site.

2.3 Adjoining Property Use

The subject property is located within a mixed agricultural and undeveloped desert area south of Holtville, California. Adjacent properties consist of the International Border with the Republic of Mexico along the southern boundary of the subject site and the All American Canal along the northern margin of the subject site.

2.4 Physical Site Characteristics

Topography: Topographic maps (USGS 7.5 minute Bonds Corner, CA Quadrangle) indicate that the subject property elevation is approximately 35 to 60 feet above mean sea level (MSL) or Elevation 1035 to 1060 (local datum). The Imperial Irrigation District, which supplies power and raw (irrigation) water to the area, established local datum by equating mean sea level to El. 1000.00 feet. The shoreline for the ancient Lake Cahuilla crosses the site at El. +43 ft. MSL.

Geologic Setting: The subject property is located in the Colorado Desert Physiographic province of southern California. The dominant feature of the Colorado Desert province is the Salton Trough, a geologic structural depression resulting from large-scale regional faulting. The trough is bounded on the northeast by the San Andreas Fault and the southwest by faults of the San Jacinto Fault Zone. The Salton Trough represents northward extension of the Gulf of California, which has experienced continual in-filling with both marine and non-marine sediments since the Miocene Epoch (25 million years before present). The tectonic activity that formed the trough continues at a high rate as evidenced by deformed young sedimentary deposits and high levels of historic seismicity.

The subject property is directly underlain by Holocene (0-11,000 years before present) Cahuilla Lake sediments, which consist of interbedded lenticular and tabular sand, silt, and clay. The predominant surface soil is silty clay. The Holocene lake deposits are considered to be less than 100 feet thick and are characterized by surficial clay and silt deposits with varying amounts of fine sand. The topography of the Imperial Valley is relatively flat, with few significant land features. The valley floor slopes gently to the north (less than 0.5 percent) from an elevation of sea level at Calexico to approximately 225 feet below sea level at the Salton Sea.

Soil Conditions: The U. S. Soil Conservation Service compiled a map of surface soil conditions and published a soil survey report including maps in 1980. The soil survey maps indicate that surficial deposits at the subject property and surrounding area consist predominantly of silt and silty sand loams of the Indio-Vint, Niland, Rositas and Vint soil groups (see Appendix B). These loams are formed in sediment and alluvium of mixed origin (Colorado River overflows and fresh-water lake-bed sediments). Based on Unified Soil Classification System presented in the Soils Survey Report, the permeability of these soils is expected to be low to moderate.

Groundwater Conditions: The groundwater in the vicinity of the subject property is brackish and is encountered at a depth of near surface to greater than 50 feet below the ground surface. Depth to groundwater may fluctuate due to localized geologic conditions, water level and seepage from the All American Canal, precipitation, irrigation, drainage and construction practices in the region. Based on the regional topography, groundwater flow is assumed to be generally towards the northwest within the subject property area. Flow directions may also vary locally across and in the vicinity of the subject property.

3.0 USER PROVIDED INFORMATION

In order to qualify for one of the *Landowner Liability Protections (LLPs)* offered by the Small Business Liability Relief and Brownfields Revitalization Act of 2001 (the *Brownfields Amendments*), the *User* must provide the following information (if available) to the *environmental professional*. Failure to provide this information could result in a determination that *all appropriate inquiry* is not complete. The user was asked to provide information or knowledge of the following:

- Environmental cleanup liens that are filed or recorded against the subject property.
- Activity and land use limitations that are in place on the subject property or that have been filed or recorded in a registry.
- Specialized knowledge or experience of the person seeking to qualify for the LLPs.
- Relationship of the purchase price to the fair market value of the *property* if it were not contaminated.
- Commonly known or *reasonably ascertainable* information about the *property*.
- The degree of obviousness of the presence or likely presence of contamination at the *property*, and the ability to detect the contamination by appropriate investigation.
- The reason for preparation of this Phase I ESA.

A user questionnaire was provided to the user to aid in gathering information that may be pertinent to the evaluation of the subject property for environmental conditions. The completed user questionnaire is provided in Appendix G.

3.1 Title Records

GS Lyon reviewed preliminary title reports as part of this assessment and did not find past ownership or easements that would indicate environmentally hazardous uses on the parcels.

3.2 Environmental Liens or Activity and Use Limitations

An environmental lien is a charge, security, or encumbrance upon the title to a property to secure the payment of a cost, damage, debt, obligation, or duty arising out of response actions, cleanup, or other remediation of hazardous substances or petroleum products upon the property. According to the User Questionnaire, Ms. Jamie Nagel of Apex Energy Solutions, LLP is not aware of any Environmental Liens or Activity and Use Limitations associated with the subject property that have been filed or recorded under federal, tribal, state or local law (Appendix G). No environmental liens associated with the subject property were noted in the preliminary title report.

3.3 Specialized Knowledge

According to the User Questionnaire, Ms. Nagel is not aware of any specialized knowledge or experience associated with the subject property or nearby properties. GS Lyon does not have any personal knowledge of the subject property.

3.4 Commonly Known or Reasonable Ascertainable Information

No information was provided by the Client regarding any commonly known or reasonably ascertainable information within the local community that is material to RECs in connection with the subject property.

3.5 Valuation Reduction for Environmental Issues

The client indicated that the purchase price of this property reasonably reflects the fair market value of the property with no discounts for environmental issues.

3.6 Owner, Property Manager, and Occupant Information

The current owner of the subject property is the Doyle Family 2010 Trust. The subject property is currently undeveloped desert land. No property manager or occupant information is available.

3.7 Previous Reports and Other Provided Documentation

No previous reports or other pertinent documentation was provided to GS Lyon for review during the course of this assessment.

4.0 RECORDS REVIEW

A review of historic aerial photographs (Appendix C), historic topographic maps (Appendix D), governmental regulatory databases (Appendix E), other regulatory and agency databases (Appendix F), and historic telephone and city directories was performed to evaluate potentially adverse environmental conditions resulting from previous ownership and uses of the subject property. The details of the review are presented in Sections 4.1 through 4.5 of this report.

4.1 Regulatory Database Review

4.1.1 Standard Environmental Record Sources

GS Lyon Consultants contracted Environmental Data Resources, Inc. (EDR) of Shelton, Connecticut which queries and maintains comprehensive environmental databases and historical information, including proprietary databases, aerial photography, topographic maps, Sanborn Maps, and city directories to generate a compilation of Federal, State and Tribal regulatory lists containing information regarding hazardous materials occurrences on or within the prescribed radii of ASTM E1527-13. The search of each database was conducted using the approximate minimum search distances from the subject property defined by the ASTM E1527-13 Standard. The purpose of the records review is to obtain and review *reasonably ascertainable* records that will help identify *recognized environmental conditions* or *historical recognized environmental conditions* in connection with the subject property.

EDR's Phase I ESA search package was ordered and performed on August 27, 2020. The search package included: Radius Map with Geocheck, aerial photographs, and historic topographic maps. The results of EDR's search were used to evaluate if the subject property and/or properties within prescribed search distances are listed as having a past or present record of actual or potential environmental impact. Inclusion of a property in a government database list does not necessarily indicate that the property has an environmental problem.

The following is a brief synopsis of sites identified in the EDR Radius Map with Geocheck report. The government record search report is included in its entirety in Appendix E.

Federal NPL List

The Environmental Protection Agency's (EPA) National Priorities List (NPL) of uncontrolled or abandoned hazardous waste sites was reviewed for risk sites within a 1 mile radius of the subject property. The NPL identifies sites for priority cleanup and long-term care of properties under the Superfund Program that are contaminated with hazardous substances.

The database search did not identify any NPL sites within 1 mile of the subject property.

Federal CERCLIS List

The EPA's Comprehensive Environmental Response, Compensation, and Liability Information System (CERCLIS) listings were reviewed to determine if risks sites within ½ mile are listed for investigation. The CERCLIS database identifies hazardous waste sites that are on or proposed to be included in the NPL and sites that require investigation and possible remedial action to mitigate potential negative impacts on human health or the environment.

The CERCLIS database search did not identify any risk sites within 0.5 mile of the subject property.

Federal CERCLIS – No Further Remedial Action Planned

The EPA's CERCLIS – No Further Remedial Action Planned (NFRAP) database was reviewed to determine if risks sites within ½ mile are listed. CERCLIS NFRAP site are risk sites that have been removed from and archived from the inventory of CERCLIS sites. Archived status indicates that, to the best of EPA's knowledge, assessment at the subject property has been completed and the EPA has determined that no further steps will be taken to list this subject property on the NPL, unless information indicates this decision was not appropriate or other considerations require a recommendation for listing at a later time.

This designation is for sites where no contamination was found, contamination was quickly removed without the need for the subject property to be placed on the NPL, or the contamination was not serious enough to require Federal Superfund action or NPL consideration.

The CERCLIS – NFRAP database search did not identify any risk sites within ½mile of the subject property.

Federal RCRA List

The Federal Resource Conservation Recovery Act (RCRA) Notifiers List was reviewed to determine if RCRA treatment, storage or disposal sites (TSD) are located within 1 mile of the subject property. The RCRA Correction Action Sites List (CORRACTS) is maintained for risk sites which are undergoing "a corrective action". A corrective action order is issued when there has been a release of hazardous waste constituents into the environment from a RCRA facility.

The RCRA and RCRA CORRACTS database searches did not identify any RCRA TSD or RCRA CORRACTS risk sites within ½ mile of the subject property.

The RCRA regulated hazardous waste generator notifiers list was reviewed to determine if RCRA generator facilities are located on or adjoining the subject property. No RCRA generator facilities within ¼ mile of the subject property were identified in the database.

Federal ERNS List

The Federal Emergency Response Notification System (ERNS) List was reviewed to determine if reported release of oil and/or hazardous substances occurred on the subject property.

The ERNS database searches did not identify any reported releases for the subject property.

State and Tribal NPL List

The Environmental Protection Agency's (EPA) National Priorities List (NPL) of uncontrolled or abandoned hazardous waste sites was reviewed for risk sites within a 1 mile radius of the subject property. The NPL identifies sites for priority cleanup and long-term care of properties under the Superfund Program that are contaminated with hazardous substances.

The database search did not identify any NPL sites within 1 mile of the subject property.

State and Tribal equivalent CERCLIS

The Department of Toxic Substances Control's (DTSC's) Site Mitigation and Brownfields Reuse Program's (SMBRP's) EnviroStor database identifies sites that have known contamination or sites for which there may be reasons to investigate further. The database includes the following site types: Federal Superfund sites (National Priorities List (NPL)); State Response, including Military Facilities and State Superfund; Voluntary Cleanup; and School sites. EnviroStor provides similar information to the information that was available in CalSites, and provides additional site information, including, but not limited to, identification of formerly-contaminated properties that have been released for reuse, properties where environmental deed restrictions have been recorded to prevent inappropriate land uses, and risk characterization information that is used to assess potential impacts to public health and the environment at contaminated sites.

The EnviroStor database search did not identify any reported releases for the subject property.

State and Tribal Leaking Underground Storage Tank Sites

The California State Water Resources Control Board (SWRCB) maintains a list of information concerning reported leaking underground storage tanks (LUST). The LUST inventory list was reviewed to determine if any LUSTs are located within ½ mile the subject property.

The SWRCB LUST database did not identify any risk sites within ½ mile of the subject property.

State and Tribal Underground and Aboveground Storage Tank Sites

The California State Water Resource Control Board (SWRCB) underground storage tank (UST) and above ground storage tank (AST) inventory list was reviewed to determine if any UAST's are located on or adjacent to the subject property.

The SWRCB UST and AST databases did not identify any risk sites within ¼ mile of the subject property.

Solid Waste Disposal/Landfill Facilities

The Solid Waste Disposal/Landfill Sites records typically contain an inventory of solid waste disposal facilities or landfills in a particular state. The data comes from the Integrated Waste Management Board's Solid Waste Information System (SWIS) database.

A review of the SWF/LF list database did not identify any risk sites within ½ mile of the subject property.

Unmapped (Orphan) Sites

Not all sites or facilities identified in the database records can be accurately located in relation to the Subject Property due to incomplete information being supplied to the regulatory agencies and are referred to as "orphan sites" by EDR.

The "Orphan Summary" section of the EDR Radius Map Report identified several orphan sites. Based on a drive-by reconnaissance of the Subject Property vicinity and review of location and status information provided in the database report, none of the identified orphan sites are located within the search radii for databases specified by the Standard.

No unmapped (orphan) listings were reported.

4.1.2 Additional Environmental Record Sources

California Department of Toxic Substances Control (DTSC) Records – Envirostor Database: EnviroStor is an online search and Geographic Information System tool for identifying sites that have known contamination or sites for which there may be reasons to investigate further. Public Access to EnviroStor is accessible via the DTSC Web Page located at: <http://www.envirostor.dtsc.ca.gov/public/>. The EnviroStor database includes the following site types: Federal Superfund sites (National Priority List); State Response, including Military Facilities and State Superfund; Voluntary Cleanup; and School sites. The information includes site name, site type, status, address, any restricted use (recorded deed restrictions), past use(s) that caused contamination, potential contaminants of concern, potential environmental media affected, site history, planned and completed activities. The EnviroStor database also contains current and historical information relating to Permitted and Corrective Action facilities. The EnviroStor database includes current and historical information on the following permit-related documents: facility permits; permit renewal applications; permit modifications to an existing permit; closure of hazardous waste management units (HWMUs) or entire facilities; facility corrective action (investigation and/or cleanup); and/or post-closure permits or other required post-closure activities.

The EnviroStor database was queried on September 9, 2020. A map showing the results of the query is provided in Appendix F. No reported cases were found on the subject property. No risk sites were located within 1 mile of the subject property.

California State Water Resources Control Board Records – GeoTracker Database: GeoTracker is a geographic information system (GIS) maintained by the California State Water Resources Control Board (SWRCB) that provides online access to environmental data at <http://www.geotracker.swrcb.ca.gov/>. GeoTracker tracks regulatory data about underground fuel tanks, fuel pipelines, and public drinking water supplies. Site information from the Spills, Leaks, Investigations, and Cleanups (SLIC) Program is also included in GeoTracker.

The GeoTracker database was queried for environmental data pertaining to the Subject property on September 9, 2020. A map showing the results of the query is provided in Appendix F. No reported cases were found on the subject property. No risk sites were located within 1 mile of the subject property.

CUPA Records Search: The Unified Program consolidates, coordinates, and makes consistent the administrative requirements, permits, inspections, and enforcement activities of six environmental and emergency response programs. Cal/EPA and other state agencies set the standards for their programs while local governments implement the standards—these local implementing agencies are called Certified Unified Program Agencies (CUPA).

The DTSC Imperial CUPA office was contacted (Veronica Lopez) by email on September 9, 2020. CUPA records were searched for environmental issues related to the subject property. The DTSC indicated that records are filed per address, and with no known address associated with the subject property, no records were found associated with the subject property.

4.2 Historical Use Records

ASTM E1527-13 requires the environmental professional to identify all obvious uses of the property from the present back to the property's first developed use or 1940, whichever is earliest. This information is collected to identify the likelihood that past uses have led to RECs in connection with the property. This task is accomplished by reviewing standard historical sources to the extent that they are necessary, reasonably ascertainable, and likely to be useful. These standard records include aerial photographs, fire insurance maps, property tax files, land title records, topographic maps, city directories, telephone directories, building department records, and zoning/land use records.

The general type of historical use (i.e., commercial, retail, residential, industrial, undeveloped, office) should be identified at 5-year intervals, unless the specific use of the property appears to be unchanged over a period longer than 5 years. The historical research is complete when the use is defined or when data failure occurs. Data failure occurs when all of the standard historical sources have been reviewed, yet the property use cannot be identified back to its first developed use or to 1940. Data failure is not uncommon in trying to identify the use of the property at 5-year intervals back to first use or 1940, whichever is earlier.

GS Lyon reviewed the following historical records to identify obvious uses of the subject property from the present back to the property's first developed use, or to 1940, whichever is earlier. The results of this research and data failure, if encountered, are presented in the following sections.

4.2.1 Title Records

GS Lyon was provided with preliminary title records for review as part of this assessment.

4.2.2 Sanborn Fire Insurance Maps

Sanborn Fire Insurance Maps are large scale maps depicting the commercial, industrial, and residential sections of various cities across the United States. Since the primary use of the fire insurance maps was to assess the buildings that were being insured, the existence and location of fuel storage tanks, flammable or other potentially toxic substances, and the nature of businesses are often shown on these maps. Due to the rural undeveloped nature of the subject property and vicinity for the years the Sanborn Fire Insurance Maps were available for this subject property, no maps are available for the subject property.

4.2.3 Aerial Photographs

Aerial photographs obtained from Environmental Data Resources (EDR) dating back to 1937 and Google Earth aerial photographs dating back to 1996 were reviewed for historical development of the subject property. Reproductions of the historical aerial photographs reviewed are included in Appendix C.

The 1937 aerial shows the western portion of the subject site as appearing to be a fallow agricultural field. The eastern portion is vacant desert land. The recently constructed All American Canal (Bureau of Reclamation – Boulder Canyon Project – 1933) is located north of the subject site. Two canals cross the All American Canal and the western portion of the subject site from Mexico.

The 1953 aerial photograph shows the western portion of the subject site as being a fallow agricultural field. The canals that crossed the All American Canal have been removed leaving a heavily brushed area in the western portion of the subject site. The eastern portion is still vacant desert land.

The 1976 aerial photograph is similar to the 1953 aerial photograph.

The 1985 aerial photograph shows a circular agricultural area occupying the eastern portion of the subject site. This is the location of the center-pivot sprinkler. The eastern portion of the subject site is vacant with overgrown brush.

The 1996, 2002, 2006 and 2010 aerial photographs are similar to the 1985 aerial photograph. Several small structures are noted in the area of the farm yard in the north-central portion of the subject site.

The 2014 aerial photograph shows that additional desert land to the west of the circular field has been cleared for agricultural use. Standing water (All American Canal seepage) and surficial salts are noted in the western portion of the subject site.

The 2018 aerial photograph shows the subject site as being similar to the present time. The agricultural fields have been fallowed.

4.2.4 Street Directories

GS Lyon Consultants conducted a search of historic city directories for the subject property. City directories are used for locating individuals and businesses in a particular urban or suburban area. City directories are generally divided into three sections: a business index, a list of resident names and addresses, the name and type of businesses (if unclear from the name). While city directory coverage is comprehensive for major cities, it may be spotty for rural and small towns.

Polk City Directories: The Polk City Directories for the years 1965 and 1983 were reviewed. No listings were found for the subject property.

4.2.5 Historic Topographic Maps

Historic topographic maps (1907, 1940, 1947, 1957, 1976, and 2012), USGS 7.5 Min. Bonds Corner, CA Quadrangle, showed the subject property as being undeveloped (Appendix D). The All American Canal was not present in the 1907 topographic map, but appears in the 1940 map. The canal was constructed in the 1930s as part of the US Bureau of Reclamation – Boulder Canyon Project.

4.2.6 Historical Telephone Directories

Telephone Directories: Telephone directories for the Imperial County, which included the City of Calexico businesses published in 1941, 1955, 1965, 1974, 1994, and 2004 were reviewed. No service stations, chemical or petroleum manufacturers, distributors, or automotive repair facilities were noted at or in the immediate vicinity of the subject site.

4.3 Historical Use Summary

4.3.1 Summary of the Historical Use of Property

Based on a review of the historical information, the western portion of the subject property was first developed prior to 1937 for agricultural use, but has been fallow since at least 1937. The eastern portion of the subject site has been vacant desert land until about 1980 when a center-pivot irrigation system was installed and a circular agricultural field was developed.

4.3.2 Summary of the Historical Use of Adjacent Properties

Historically, the properties located immediately adjacent to the subject property have been comprised of vacant desert land to the east, the Republic of Mexico to the south, and the All American Canal and agricultural fields to the north.

5.0 SITE RECONNAISSANCE

5.1 Methodology and Limiting Conditions

A site reconnaissance was performed by Mr. Steven Williams, a consulting geologist to GS Lyon Consultants, on September 22, 2020. The site visit consisted of a driving the perimeter of the subject property and randomly crossing the subject property. The reconnaissance included visual observations of surficial conditions at the subject property and observation of adjoining properties to the extent that they were visible from public areas. Mr. Williams was accompanied during the site reconnaissance by Ramon Gonzalez, a representative for Apex Energy Solutions, LLC.

The site reconnaissance was limited to visual and/or physical observation of the exterior and interior of the subject property and its improvements, the current uses of the property and adjoining properties, and the current condition of the property. The site visit evaluated the subject property and adjoining properties for potential hazardous materials/waste and petroleum product use, storage, disposal, or accidental release, including the following: presence of tank and drum storage; mechanical or electrical equipment likely to contain liquids; evidence of soil or pavement staining or stressed vegetation; ponds, pits, lagoons, or sumps; suspicious odors; fill and depressions; or any other condition indicative of potential contamination. The site visit did not evaluate the presence of asbestos-containing materials, radon, lead-based paint, mold, indoor air quality, or structural defects, or other non-scope items.

A site reconnaissance can be limited by weather conditions, bodies of water, adjacent buildings, or other obstacles. The weather was warm and sunny and no access limitations were placed on the site visit.

5.2 General Site Setting

The subject property currently consists of approximately 530 acres comprised of three parcels (APNs 059-299-010, 059-300-017, and 059-300-015). The subject property is roughly triangular in plan view with the All American Canal forming the northern boundary, the International Border with the Republic of Mexico forming the southern boundary and vacant desert land forming the eastern boundary. The majority of the subject site has been cleared of desert vegetation for agricultural use. The western wedge and a small area in the north-central portion of the site are heavily vegetated.

A farm yard is located in the north-central portion of the subject site. A small masonry building housing water pumps, an above ground fuel storage tank (AST) and a storage building, all located within a chain-link fenced area comprise the farm yard. A bank of pole mounted transformers is located on the embankment of the All American Canal adjacent to the farm yard. A small equipment storage area with a disk, a trap wagon, and other miscellaneous farm implements is located northeast of the farm yard area. There are two central-pivot sprinklers that are located in the central portion of the site.

Photographs of the subject property taken on September 22, 2020 during our site reconnaissance are included in Appendix A.

5.3 Adjacent Properties

The subject property is located within a mixed agricultural and undeveloped desert area south of Holtville, California. Adjacent properties consist of the International Border with the Republic of Mexico along the southern boundary of the subject site and the All American Canal along the northern margin of the subject site.

5.4 Exterior and Interior Observations

The following conditions were specifically assessed for their potential to indicate RECs and may include conditions inside or outside structures on the subject property.

5.4.1 Hazardous Substances and Petroleum Products

GS Lyon did not observe operations that use, treat, store, dispose of, or generate hazardous materials or petroleum products on the subject property.

5.4.2 Storage Tanks

Underground Storage Tanks (USTs) – No obvious visual evidence indicating the current presence of USTs (i.e. vent pipes, fill ports, etc.) was noted.

Aboveground Storage Tanks (ASTs) – One (1) above ground fuel tank (AST) was observed within the fenced farm yard. Access to the tank was not available to determine if it contained fuel.

5.4.3 Odors

No obvious strong, pungent, or noxious odors were noted during the site reconnaissance.

5.4.4 Pools of Liquid

Pools of liquid were not observed during the site reconnaissance.

5.4.5 Drums and Containers

GS Lyon observed several steel 55-gallon drums on the subject property. No fluids were observed in the drums that were accessible.

5.4.6 Unidentified Substance Containers

GS Lyon did not observe open or damaged containers containing unidentified substances at the subject property.

5.4.7 Suspect Polychlorinated Biphenyl (PCB) Containing Equipment

Pole-mounted sealed electrical transformers owned and maintained by the Imperial Irrigation District (IID) are located on the embankment of the All American Canal adjacent to the farm yard on the subject property. In recent years, the IID has replaced all transformers that contained PCBs. Stickers were observed on the transformers that indicated that they had been tested for PCBs. No leaks were noted during our site visit.

5.5 Interior Observations

Access to the pump building within the fenced farm yard was not obtainable; therefore, interior observations were not made of the structure.

5.6 Exterior Observations**5.6.1 Pits, Ponds, and Lagoons**

No pits, ponds, or lagoons were noted on the subject property.

5.6.2 Stained Soils or Pavement

No evidence of significantly stained soil or pavement was noted on the subject property.

5.6.3 Stressed Vegetation

No evidence of stressed vegetation attributed to potential contamination was noted on the subject property.

5.6.4 Solid Waste

No dumpsters or solid waste containers exist on the subject property.

5.6.5 Wastewater

No wastewater is generated at the subject property.

5.6.6 Wells

No evidence of wells (dry wells, drinking water, observation wells, groundwater monitoring wells, irrigation wells, injection wells or abandoned wells) was noted on the subject property. Water for the center-pivot sprinkler system was supplied from the All American Canal.

5.6.7 Septic Systems

No septic systems are present on the subject property.

5.7 Non-Scope Issues

ASTM guidelines identify non-scope issues, which are beyond the scope of a Phase I ESA as defined by ASTM. These issues may affect environmental risk at the subject property and may warrant discussion and/or assessment. Some of these non-scope issues include; asbestos-containing building materials, radon, lead-based paint, and wetlands which are discussed below.

5.7.1 Asbestos-Containing Building Materials

The potential for asbestos containing materials (ACM) existing at the subject property is low due to the lack of structures other than the small masonry structure at the farm yard.

5.7.2 Lead-Based Paint

The potential or lead based paint residues existing at the subject property is very low due to the lack of development other than the small masonry structure at the farm yard.

5.7.3 Radon

The subject property is located in Zone 3 as shown on the EPA Map of Radon Zones indicating a predicted average indoor radon screening level of less than 2 pCi/L. Radon gas is not believed to be a potential hazard at the subject property.

5.7.4 Agricultural Use

Based on our review of environmental records, historical documents, and subject property conditions, the property has been in agricultural use and/or vacant since the 1930's. Residues of currently available pesticides and currently banned pesticides such as DDT/DDE may be present in near surface soils in limited concentrations. The concentrations of these pesticides found on other Imperial Valley agricultural sites are typically less than 25% of the current regulatory threshold limits and, at those levels, are not considered a significant environmental hazard. The presence and concentration of near surface pesticides at this subject property can be accurately characterized only by site-specific sampling and testing.

6.0 INTERVIEWS

GS Lyon interviewed various individuals familiar with the subject property, as identified to us, and/or government officials in order to evaluate historical uses and identify potential RECs existing on the subject property. The individuals interviewed were asked to provide responses in good faith and to the best of their knowledge. The following sections identify the individuals interviewed and summarize the information each provided; however, additional information provided by these individuals may be presented in other sections of this report.

Interviews with past owners, operators and occupants were not reasonably ascertainable and thus constitute a data gap.

6.1 Interview with Owner

GS Lyon we not able to contact the current property owner; therefore, no interview was conducted.

6.2 Interview with the Site Manager

The subject property is vacant, undeveloped land; therefore, there is no site manager.

6.3 Interview with Occupants

The subject property is vacant, undeveloped land; therefore, there are no occupants.

6.4 Interview with Local Government Officials

The DTSC Imperial CUPA office was contacted (Veronica Lopez) by email on September 9, 2020. CUPA records were searched for environmental issues related to the subject property. The DTSC indicated that records are filed per address, and with no known address associated with the subject property, no records were found associated with the subject property.

7.0 EVALUATION

7.1 Summary of Findings

The subject property is located in an area generally developed for agricultural use east of Calexico, California. The western portion of the subject property has been developed as agricultural use since at least the 1930s according to the historical information obtained and reviewed during this site assessment. The eastern portion of the site was vacant desert land until about 1980 when a portion was developed for agricultural use.

7.2 Conclusions

GS Lyon has performed a Phase I Environmental Site Assessment in general conformance with the scope and limitations of ASTM E1527-13 of the approximately 530-acre property located on the south side of the All American Canal at Bonesteele Road approximately 10 miles south of Holtville, California. Any exceptions to, or deviations from, this practice are described in Section 1.4 of this Phase I ESA report. This assessment has revealed the following recognized environmental conditions (RECs) in connection with the subject property:

7.2.1 Recognized Environmental Conditions

A *recognized environmental condition (REC)* refers to the presence or likely presence of any hazardous substances or petroleum products in, on, or at a property: (1) due to any release to the environment; (2) under conditions indicative of a release to the environment; or (3) under conditions that pose a material threat of a future release to the environment. under conditions that indicate an existing release, a past release, or a material threat of a release of any hazardous substances or petroleum products into structures on the property or into the ground, groundwater, or surface water of the property. The term REC includes hazardous substances and petroleum products even under conditions that might be in compliance with laws. The term is not intended to include "de minimis" conditions as defined in Section 7.2.3 of this report.

This Phase I ESA has revealed no evidence of *recognized environmental conditions* in connection with the subject property.

7.2.2 Historical Recognized Environmental Conditions

A *historical recognized environmental condition (HREC)* refers to a past *release* of any *hazardous substances* or *petroleum products* that has occurred in connection with the *property* and has been addressed to the satisfaction of the applicable regulatory authority or meeting unrestricted use criteria established by a regulatory authority, without subjecting the *property* to any required controls (for example, *property* use restrictions, *activity and use limitations*, *institutional controls*, or *engineering controls*).

This Phase I ESA has revealed no evidence of *historical recognized environmental conditions* in connection with the subject property.

7.2.3 Environmental Concerns and De Minimis Conditions

A *de minimis condition* is a condition that generally does not present a threat to human health or the *environment* and that generally would not be the subject of an enforcement action if brought to the attention of appropriate governmental agencies. Conditions determined to be *de minimis conditions* are not *recognized environmental conditions* nor *controlled recognized environmental conditions*.

This Phase I ESA has revealed the following *de minimis* conditions or environmental concerns in connection with the subject property:

1. Pole-mounted sealed electrical transformers owned and maintained by the Imperial Irrigation District (IID) exist on the margin of this subject property. All IID transformers containing PCB's have been replaced. ***If the transformers begin to leak, the IID should be notified and the transformers replaced.***
2. An aboveground fuel tank is located within the fenced farm yard area. If it is shown that spills or leaks had occurred, the affected soil should be cleaned up and properly disposed.

7.3 Recommendations

Based on the scope of work performed for this assessment, it is our professional opinion that no RECs have been identified in connection with the subject property that would warrant further environmental study (Phase II) at this time.

8.0 REFERENCES

40 CFR 312, Standards and Practices for All Appropriate Inquiries; Final Rule, November 2005 (AAI Rule).

American Society for Testing and Materials. 2013. Standard Practice for Environmental Site Assessments: Phase I Environmental Site Assessment Process. Designation E 1527-13. West Conshohocken, Pennsylvania. 35 pp.

Department of Toxic Substances Control. 2020. EnviroStor Database Website, <http://www.envirostor.dtsc.ca.gov/public/> .

Environmental Data Resources, Inc., *The EDR Radius Map with Geocheck*. Inquiry number 6171645, dated August 28, 2020

Environmental Data Resources, Inc., *EDR Historical Topographic Map Report*. Inquiry number 6171645, dated August 28, 2020

Environmental Data Resources, Inc., *The EDR Aerial Photo Decade Package*. Inquiry number 6171645, dated August 28, 2020

State Water Resources Control Board. 2020. GeoTracker Database Website, <http://geotracker.swrcb.ca.gov/>

United States Department of Agriculture, Natural Resources Conservation Service, Web Soil Survey, accessed via the Internet, September 2020

United States Environmental Protection Agency, EPA Map of Radon Zones (Document EPA-402-R-93-071), accessed via the Internet, September 2020

United States Geological Survey Topographic Map 1997, 7.5 minute series

APPENDIX A

PC ORIGINAL PKG



Photo 1: Looking northeast along the northern boundary of the subject site.



Photo 2: View of center-pivot sprinkler near the north-central portion of the site.



Photo 3: Masonry block pump house located at the north-central portion of the subject site.



Photo 4: Clos-up view of pump house and transformer bank.



Photo 5: Above ground fuel tank (AST) within farm yard.



Photo 6: Miscellaneous building near farm yard.



Photo 7: Farm equipment storage area east of farm yard.



Photo 8: Close-up view of farm equipment.



Photo 9: Close-up view of transformer bank. IID stickers show the transformers have been tested for PCBs.



Photo 10: Looking east across the site from the west margin of the subject site.



Photo 11: Looking south along the west margin of the subject site.



Photo 12: Looking east along the southern boundary of the subject site.



Photo 13: Looking west from the east-central portion of the subject site.



Photo 14: Looking north across the subject property.



Photo 15: Looking north from the southeast corner of the subject site.

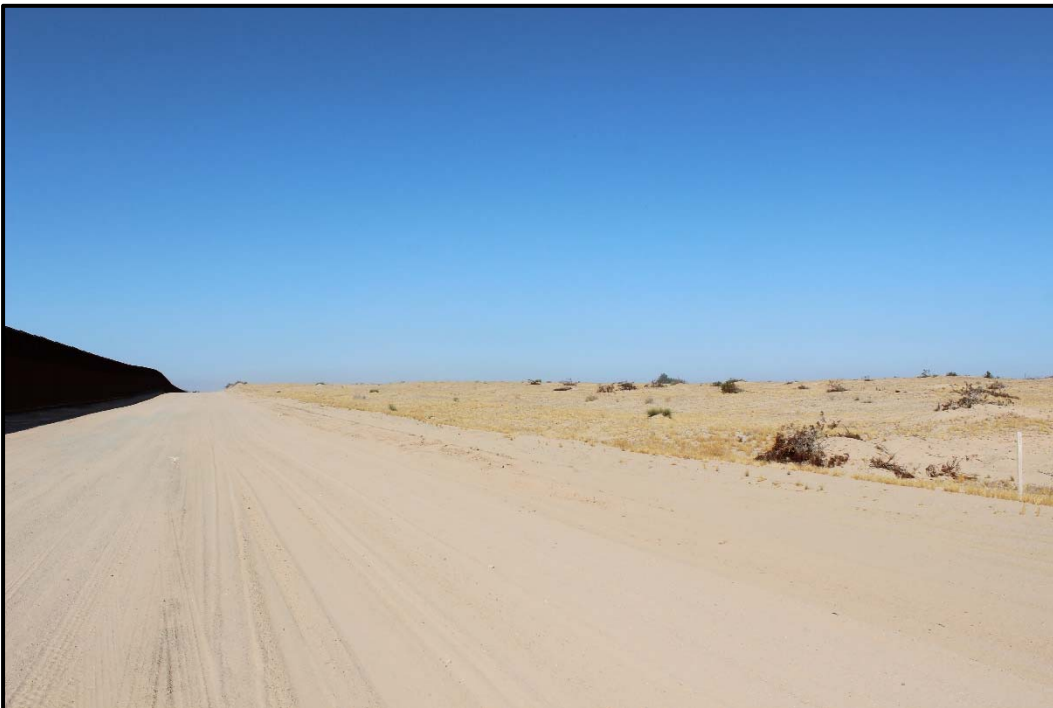
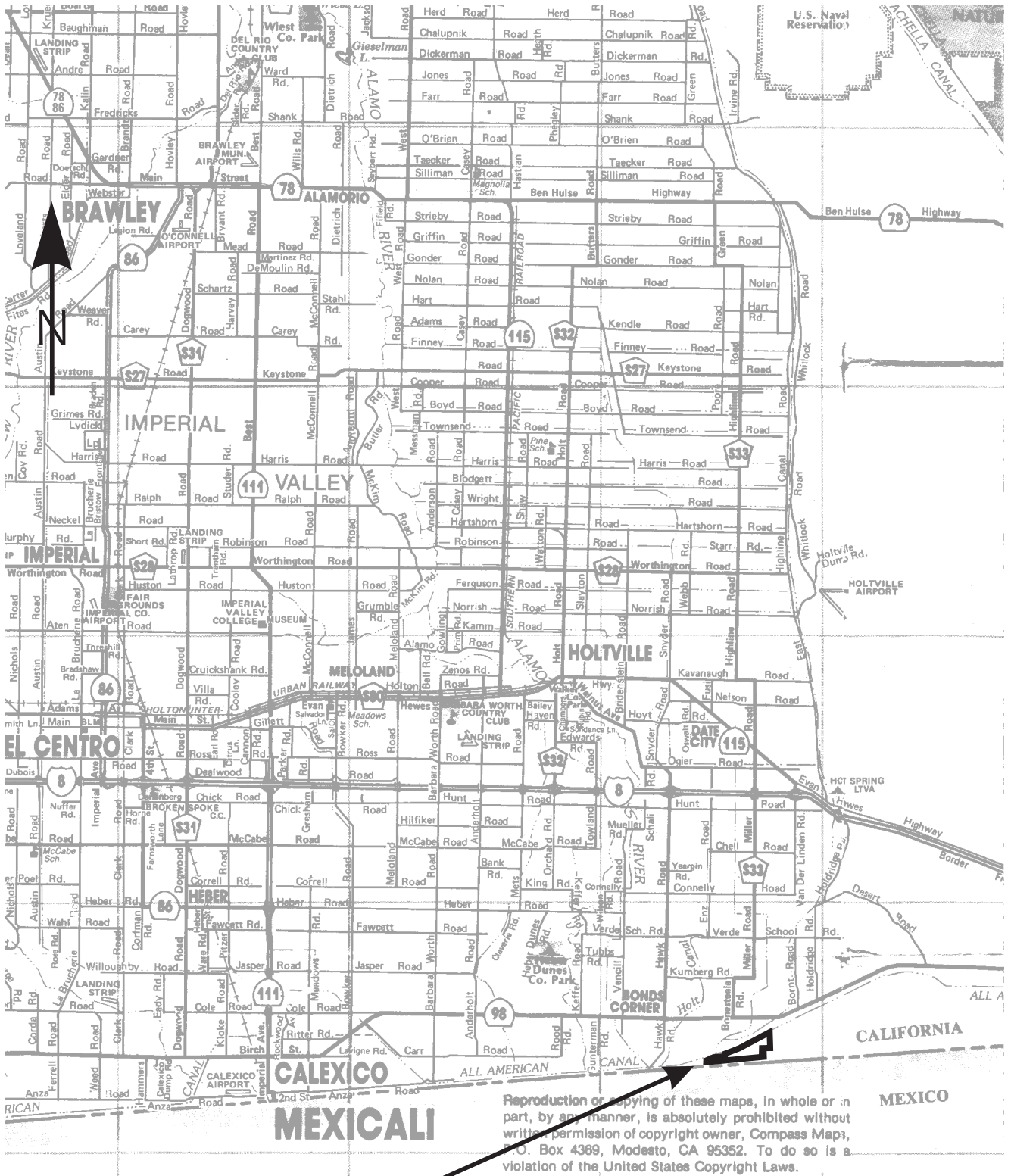


Photo 16: Looking west along the southern margin of the subject property. The United States border fence and Border Patrol road on left side of the photo.

APPENDIX B

PC ORIGINAL PKG



Reproduction or copying of these maps, in whole or in part, by any manner, is absolutely prohibited without written permission of copyright owner, Compass Maps, P.O. Box 4369, Modesto, CA 95352. To do so is a violation of the United States Copyright Laws.

Subject Site



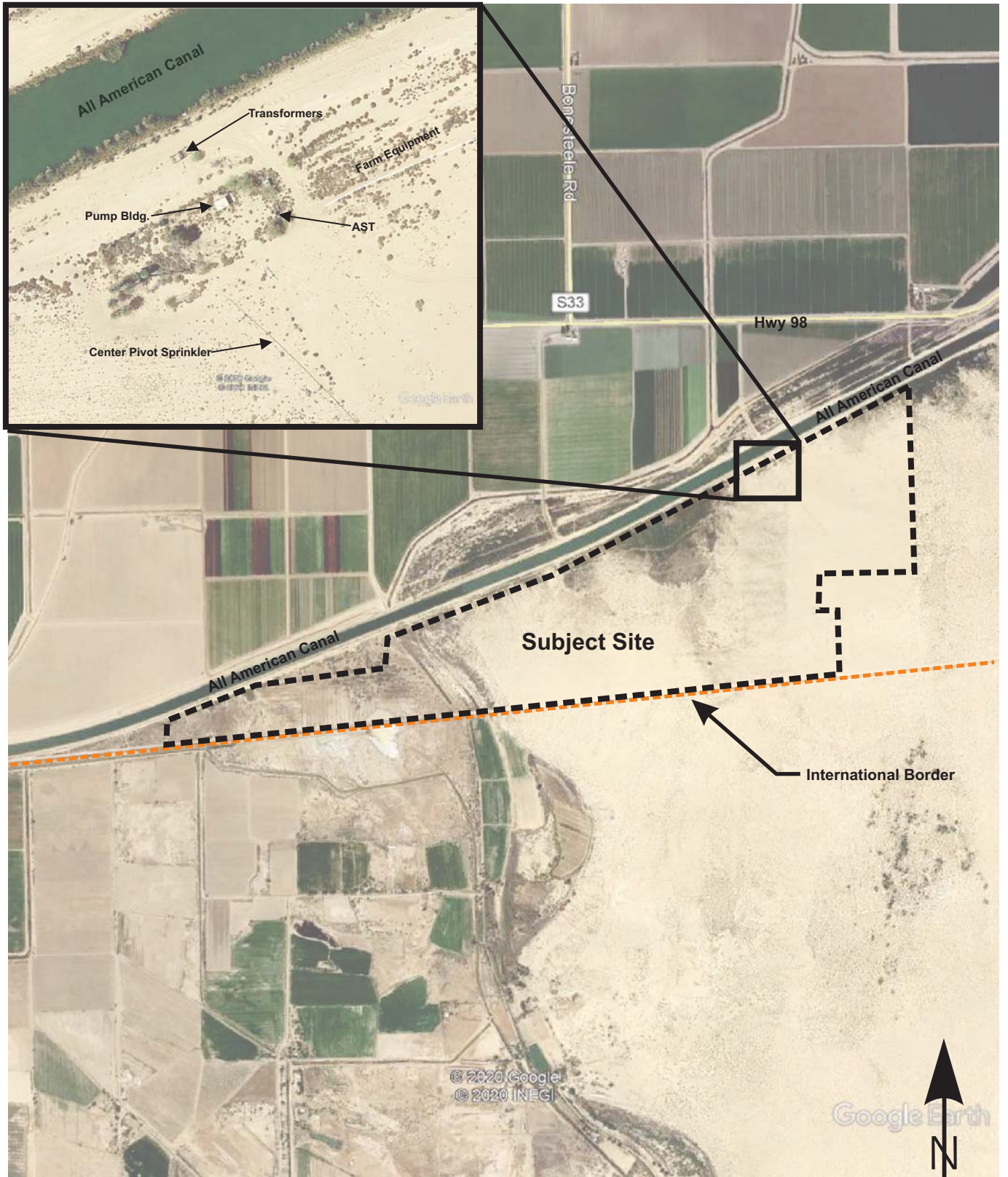
Project No.: GS2015

Vicinity Map

Plate

1

PC ORIGINAL PKG



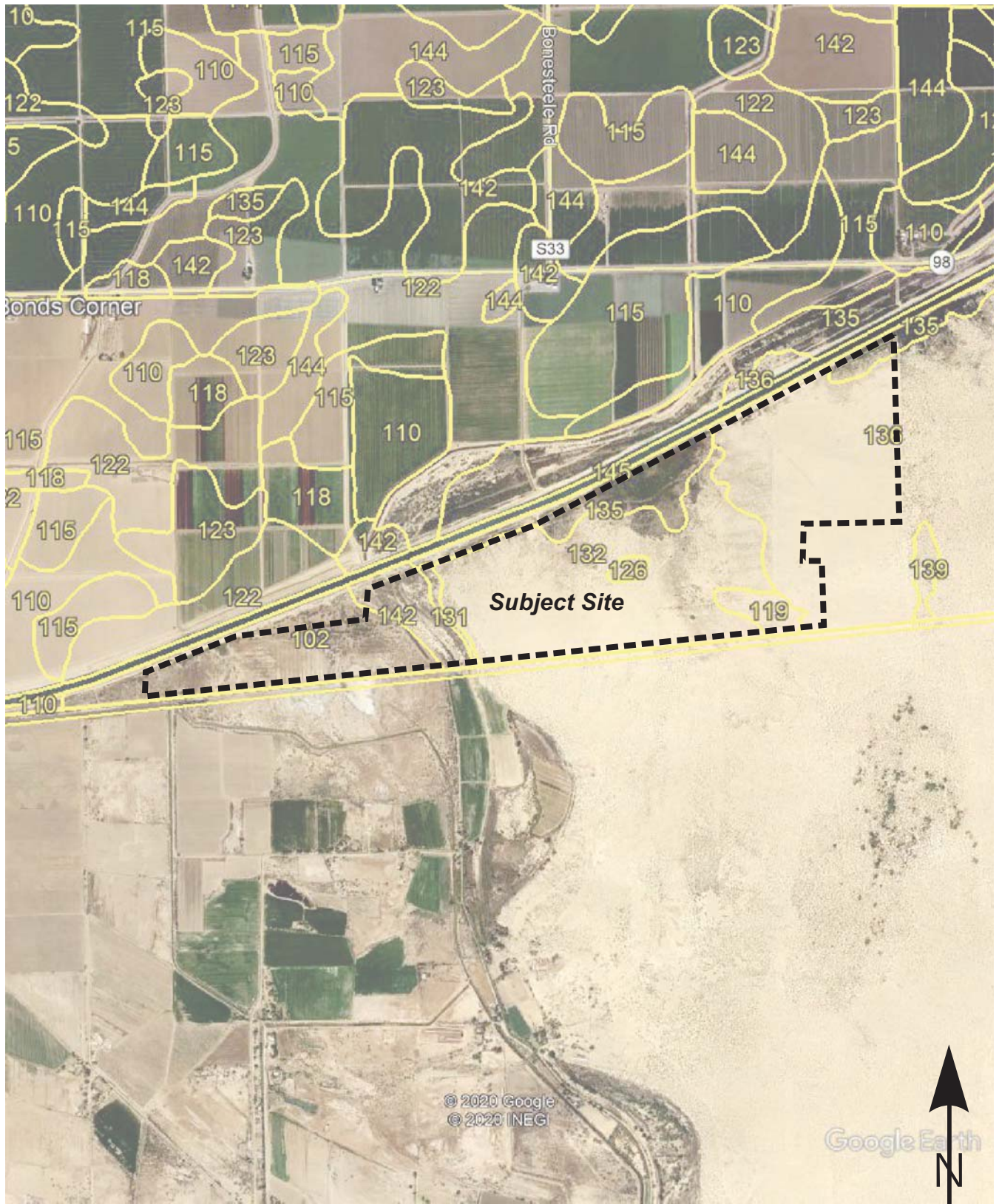
GS Lyon

Project No.: GS2015

Site Map

Plate
2

PC ORIGINAL PKG



© 2020 Google
© 2020 INEG



Google Earth

GS Lyon

Project No.: GS2015

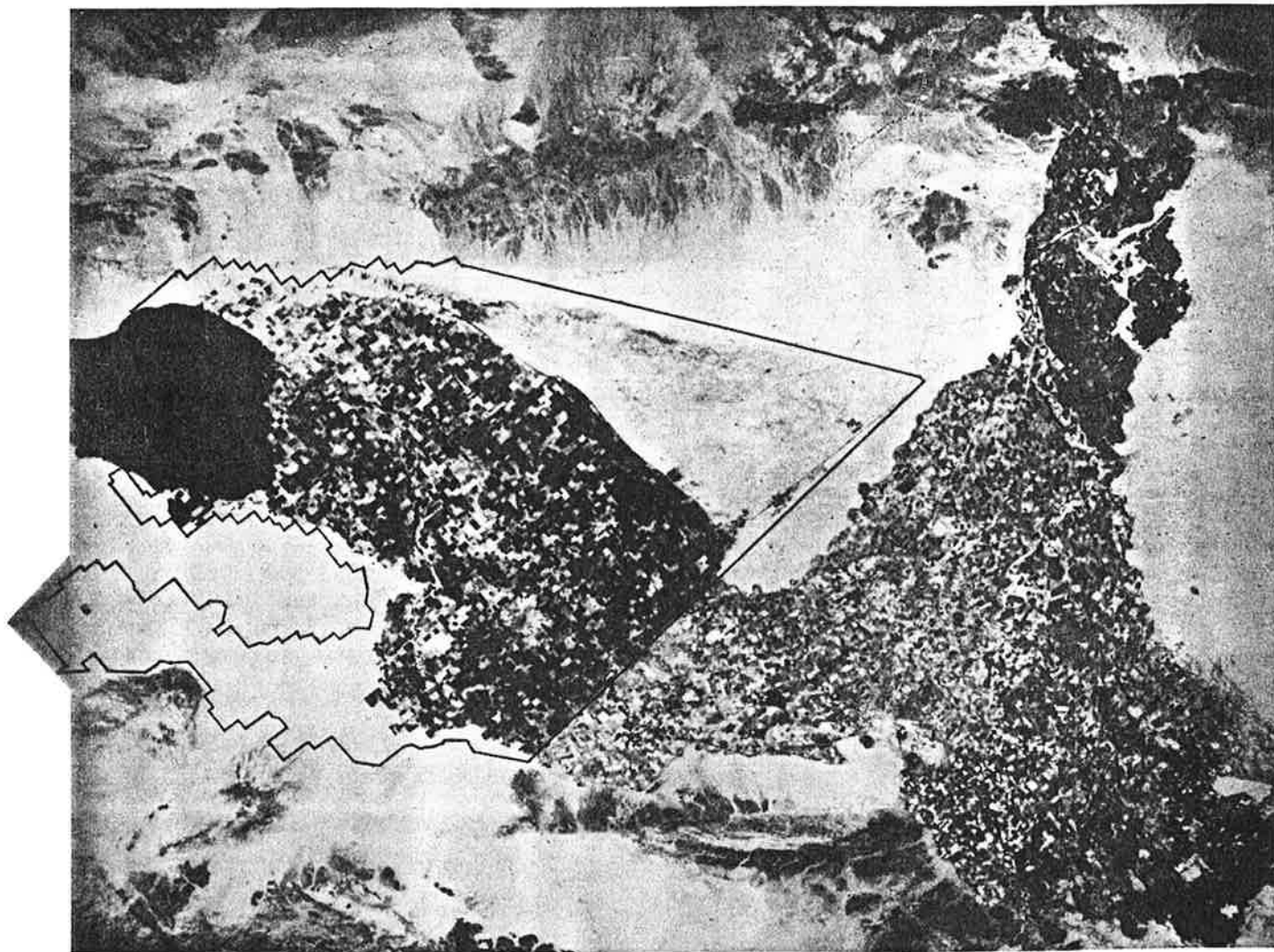
Soil Survey Map

Plate
3

PC ORIGINAL PKG

Soil Survey of

**IMPERIAL COUNTY
CALIFORNIA
IMPERIAL VALLEY AREA**



United States Department of Agriculture Soil Conservation Service
in cooperation with
University of California Agricultural Experiment Station
and
Imperial Irrigation District

PC ORIGINAL PKG

TABLE 11.--ENGINEERING INDEX PROPERTIES

[The symbol > means more than. Absence of an entry indicates that data were not estimated]

Soil name and map symbol	Depth	USDA texture	Classification		Frag-ments > 3 inches	Percentage passing sieve number--				Liquid limit	Plas-ticity index
			Unified	AASHTO		4	10	40	200		
	In				Pct					Pct	
100----- Antho	0-13 13-60	Loamy fine sand Sandy loam, fine sandy loam.	SM SM	A-2 A-2, A-4	0 0	100 90-100	100 75-95	75-85 50-60	10-30 15-40	--- ---	NP NP
101*: Antho-----	0-8 8-60	Loamy fine sand Sandy loam, fine sandy loam.	SM SM	A-2 A-2, A-4	0 0	100 90-100	100 75-95	75-85 50-60	10-30 15-40	--- ---	NP NP
Superstition-----	0-6 6-60	Fine sand----- Loamy fine sand, fine sand, sand.	SM SM	A-2 A-2	0 0	100 100	95-100 95-100	70-85 70-85	15-25 15-25	--- ---	NP NP
102*. Badland											
103----- Carsitas	0-10 10-60	Gravelly sand--- Gravelly sand, gravelly coarse sand, sand.	SP, SP-SM SP, SP-SM	A-1, A-2 A-1	0-5 0-5	60-90 60-90	50-85 50-85	30-55 25-50	0-10 0-10	--- ---	NP NP
104* Fluvaquents											
105----- Glenbar	0-13 13-60	Clay loam----- Clay loam, silty clay loam.	CL CL	A-6 A-6	0 0	100 100	100 100	90-100 90-100	70-95 70-95	35-45 35-45	15-30 15-30
106----- Glenbar	0-13 13-60	Clay loam----- Clay loam, silty clay loam.	CL CL	A-6, A-7 A-6, A-7	0 0	100 100	100 100	90-100 90-100	70-95 70-95	35-45 35-45	15-25 15-25
107*----- Glenbar	0-13 13-60	Loam----- Clay loam, silty clay loam.	ML, CL-ML, CL	A-4 A-6, A-7	0 0	100 100	100 100	100 95-100	70-80 75-95	20-30 35-45	NP-10 15-30
108----- Holtville	0-14 14-22 22-60	Loam----- Clay, silty clay Silt loam, very fine sandy loam.	ML CL, CH ML	A-4 A-7 A-4	0 0 0	100 100 100	100 100 100	85-100 95-100 95-100	55-95 85-95 65-85	25-35 40-65 25-35	NP-10 20-35 NP-10
109----- Holtville	0-17 17-24 24-35 35-60	Silty clay----- Clay, silty clay Silt loam, very fine sandy loam. Loamy very fine sand, loamy fine sand.	CL, CH CL, CH ML SM, ML	A-7 A-7 A-4 A-2, A-4	0 0 0 0	100 100 100 100	100 100 100 100	95-100 95-100 95-100 75-100	85-95 85-95 65-85 20-55	40-65 40-65 25-35 ---	20-35 20-35 NP-10 NP
110----- Holtville	0-17 17-24 24-35 35-60	Silty clay----- Clay, silty clay Silt loam, very fine sandy loam. Loamy very fine sand, loamy fine sand.	CH, CL CH, CL ML SM, ML	A-7 A-7 A-4 A-2, A-4	0 0 0 0	100 100 100 100	100 100 100 100	95-100 95-100 95-100 75-100	85-95 85-95 55-85 20-55	40-65 40-65 25-35 ---	20-35 20-35 NP-10 NP

See footnote at end of table.

TABLE 11.--ENGINEERING INDEX PROPERTIES--Continued

Soil name and map symbol	Depth	USDA texture	Classification		Frag-ments > 3 inches Pct	Percentage passing sieve number--				Liquid limit Pct	Plas-ticity index
			Unified	AASHTO		4	10	40	200		
111*: Holtville-----	0-10	Silty clay loam	CL, CH	A-7	0	100	100	95-100	85-95	40-65	20-35
	10-22	Clay, silty clay	CL, CH	A-7	0	100	100	95-100	85-95	40-65	20-35
	22-60	Silt loam, very fine sandy loam.	ML	A-4	0	100	100	95-100	65-85	25-35	NP-10
Imperial-----	0-12	Silty clay loam	CL	A-7	0	100	100	100	85-95	40-50	10-20
	12-60	Silty clay loam, silty clay, clay.	CH	A-7	0	100	100	100	85-95	50-70	25-45
112-----	0-12	Silty clay-----	CH	A-7	0	100	100	100	85-95	50-70	25-45
Imperial	12-60	Silty clay loam, silty clay, clay.	CH	A-7	0	100	100	100	85-95	50-70	25-45
113-----	0-12	Silty clay-----	CH	A-7	0	100	100	100	85-95	50-70	25-45
Imperial	12-60	Silty clay, clay, silty clay loam.	CH	A-7	0	100	100	100	85-95	50-70	25-45
114-----	0-12	Silty clay-----	CH	A-7	0	100	100	100	85-95	50-70	25-45
Imperial	12-60	Silty clay loam, silty clay, clay.	CH	A-7	0	100	100	100	85-95	50-70	25-45
115*: Imperial-----	0-12	Silty clay loam	CL	A-7	0	100	100	100	85-95	40-50	10-20
	12-60	Silty clay loam, silty clay, clay.	CH	A-7	0	100	100	100	85-95	50-70	25-45
Glenbar-----	0-13	Silty clay loam	CL	A-6, A-7	0	100	100	90-100	70-95	35-45	15-25
	13-60	Clay loam, silty clay loam.	CL	A-6, A-7	0	100	100	90-100	70-95	35-45	15-25
116*: Imperial-----	0-13	Silty clay loam	CL	A-7	0	100	100	100	85-95	40-50	10-20
	13-60	Silty clay loam, silty clay, clay.	CH	A-7	0	100	100	100	85-95	50-70	25-45
Glenbar-----	0-13	Silty clay loam	CL	A-6, A-7	0	100	100	90-100	70-95	35-45	15-25
	13-60	Clay loam, silty clay loam.	CL	A-6	0	100	100	90-100	70-95	35-45	15-30
117, 118-----	0-12	Loam-----	ML	A-4	0	95-100	95-100	85-100	75-90	20-30	NP-5
Indio	12-72	Stratified loamy very fine sand to silt loam.	ML	A-4	0	95-100	95-100	85-100	75-90	20-30	NP-5
119*: Indio-----	0-12	Loam-----	ML	A-4	0	95-100	95-100	85-100	75-90	20-30	NP-5
	12-72	Stratified loamy very fine sand to silt loam.	ML	A-4	0	95-100	95-100	85-100	75-90	20-30	NP-5
Vint-----	0-10	Loamy fine sand	SM	A-2	0	95-100	95-100	70-80	25-35	---	NP
	10-60	Loamy sand, loamy fine sand.	SM	A-2	0	95-100	95-100	70-80	20-30	---	NP
120*: Laveen-----	0-12	Loam-----	ML, CL-ML	A-4	0	100	95-100	75-85	55-65	20-30	NP-10
	12-60	Loam, very fine sandy loam.	ML, CL-ML	A-4	0	95-100	85-95	70-80	55-65	15-25	NP-10

See footnote at end of table.

TABLE 11.--ENGINEERING INDEX PROPERTIES--Continued

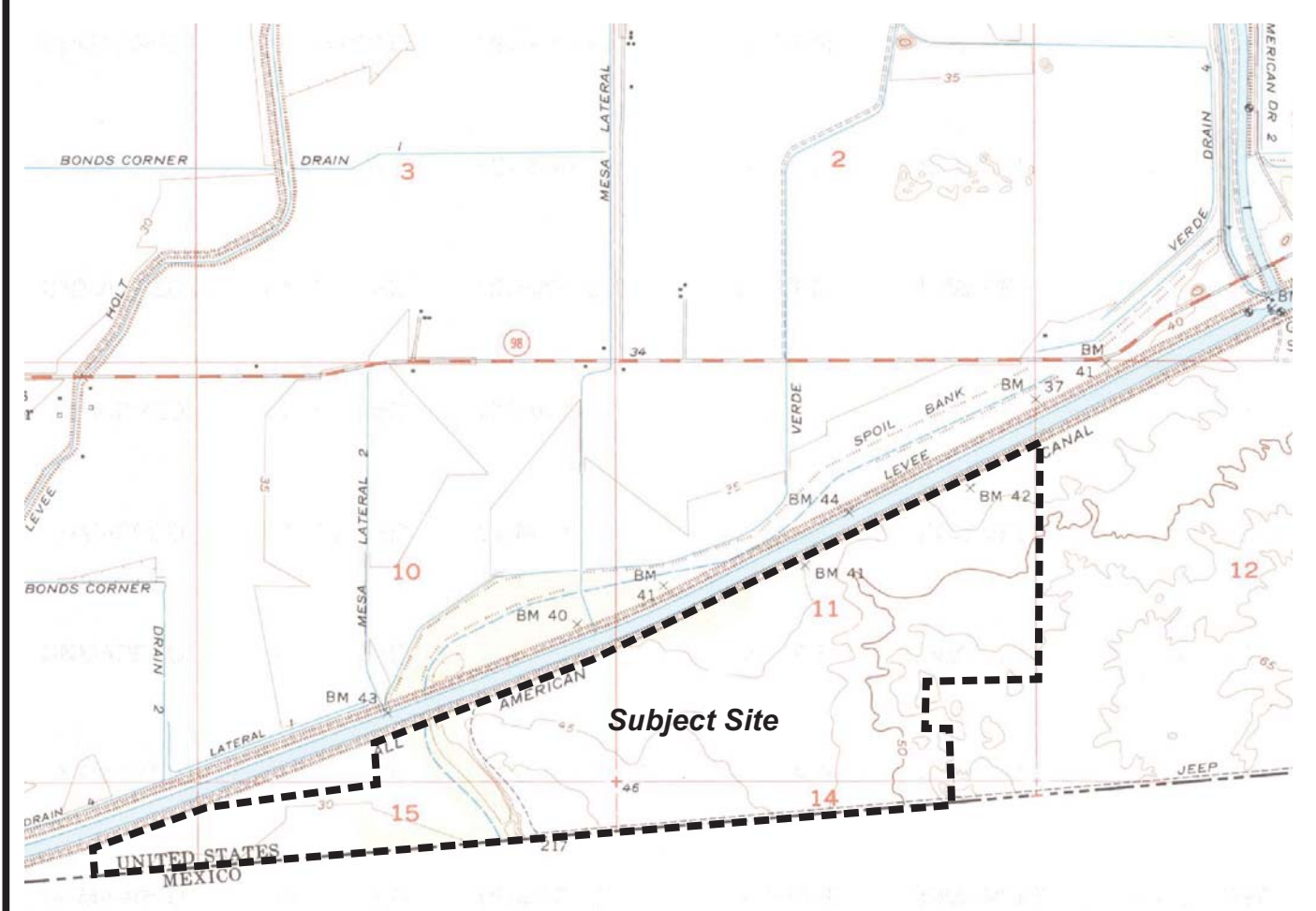
Soil name and map symbol	Depth In	USDA texture	Classification		Frag- ments > 3 inches Pct	Percentage passing sieve number--				Liquid limit Pet	Plas- ticity index
			Unified	AASHTO		4	10	40	200		
121----- Meloland	0-12	Fine sand-----	SM, SP-SM	A-2, A-3	0	95-100	90-100	75-100	5-30	---	NP
	12-26	Stratified loamy fine sand to silt loam.	ML	A-4	0	100	100	90-100	50-65	25-35	NP-10
	26-71	Clay, silty clay, silty clay loam.	CL, CH	A-7	0	100	100	95-100	85-95	40-65	20-40
122----- Meloland	0-12	Very fine sandy loam.	ML	A-4	0	95-100	95-100	95-100	55-85	25-35	NP-10
	12-26	Stratified loamy fine sand to silt loam.	ML	A-4	0	100	100	90-100	50-70	25-35	NP-10
	26-71	Clay, silty clay, silty clay loam.	CH, CL	A-7	0	100	100	95-100	85-95	40-65	20-40
123*: Meloland-----	0-12	Loam-----	ML	A-4	0	95-100	95-100	95-100	55-85	25-35	NP-10
	12-26	Stratified loamy fine sand to silt loam.	ML	A-4	0	100	100	90-100	50-70	25-35	NP-10
	26-38	Clay, silty clay, silty clay loam.	CH, CL	A-7	0	100	100	95-100	85-95	40-65	20-40
	38-60	Stratified silt loam to loamy fine sand.	SM, ML	A-4	0	100	100	75-100	35-55	25-35	NP-10
Holtville-----	0-12	Loam-----	ML	A-4	0	100	100	85-100	55-95	25-35	NP-10
	12-24	Clay, silty clay	CH, CL	A-7	0	100	100	95-100	85-95	40-65	20-35
	24-36	Silt loam, very fine sandy loam.	ML	A-4	0	100	100	95-100	55-85	25-35	NP-10
	36-60	Loamy very fine sand, loamy fine sand.	SM, ML	A-2, A-4	0	100	100	75-100	20-55	---	NP
124, 125----- Niland	0-23	Gravelly sand---	SM, SP-SM	A-2, A-3	0	90-100	70-95	50-65	5-25	---	NP
	23-60	Silty clay, clay, clay loam.	CL, CH	A-7	0	100	100	85-100	80-95	40-65	20-40
126----- Niland	0-23	Fine sand-----	SM, SP-SM	A-2, A-3	0	90-100	90-100	50-65	5-25	---	NP
	23-60	Silty clay-----	CL, CH	A-7	0	100	100	85-100	80-95	40-65	20-40
127----- Niland	0-23	Loamy fine sand	SM	A-2	0	90-100	90-100	50-65	15-30	---	NP
	23-60	Silty clay-----	CL, CH	A-7	0	100	100	85-100	80-95	40-65	20-40
128*: Niland-----	0-23	Gravelly sand---	SM, SP-SM	A-2, A-3	0	90-100	70-95	50-65	5-25	---	NP
	23-60	Silty clay, clay, clay loam.	CL, CH	A-7	0	100	100	85-100	80-100	40-65	20-40
Imperial-----	0-12	Silty clay-----	CH	A-7	0	100	100	100	85-95	50-70	25-45
	12-60	Silty clay loam, silty clay, clay.	CH	A-7	0	100	100	100	85-95	50-70	25-45
129*: Pits											
130, 131----- Rositas	0-27	Sand-----	SP-SM	A-3, A-1, A-2	0	100	80-100	40-70	5-15	---	NP
	27-60	Sand, fine sand, loamy sand.	SM, SP-SM	A-3, A-2, A-1	0	100	80-100	40-85	5-30	---	NP

See footnote at end of table.

TABLE 11.--ENGINEERING INDEX PROPERTIES--Continued

Soil name and map symbol	Depth	USDA texture	Classification		Frag-ments > 3 inches	Percentage passing sieve number--				Liquid limit	Plas-ticity index
			Unified	AASHTO		4	10	40	200		
	In				Pct					Pct	
132, 133, 134, 135-Rositas	0-9	Fine sand-----	SM	A-3, A-2	0	100	80-100	50-80	10-25	---	NP
	9-60	Sand, fine sand, loamy sand.	SM, SP-SM	A-3, A-2, A-1	0	100	80-100	40-85	5-30	---	NP
136-----Rositas	0-4	Loamy fine sand	SM	A-1, A-2	0	100	80-100	40-85	10-35	---	NP
	4-60	Sand, fine sand, loamy sand.	SM, SP-SM	A-3, A-2, A-1	0	100	80-100	40-85	5-30	---	NP
137-----Rositas	0-12	Silt loam-----	ML	A-4	0	100	100	90-100	70-90	20-30	NP-5
	12-60	Sand, fine sand, loamy sand.	SM, SP-SM	A-3, A-2, A-1	0	100	80-100	40-85	5-30	---	NP
138*: Rositas-----	0-4	Loamy fine sand	SM	A-1, A-2	0	100	80-100	40-85	10-35	---	NP
	4-60	Sand, fine sand, loamy sand.	SM, SP-SM	A-3, A-2, A-1	0	100	80-100	40-85	5-30	---	NP
Superstition-----	0-6	Loamy fine sand	SM	A-2	0	100	95-100	70-85	15-25	---	NP
	6-60	Loamy fine sand, fine sand, sand.	SM	A-2	0	100	95-100	70-85	15-25	---	NP
139-----Superstition	0-6	Loamy fine sand	SM	A-2	0	100	95-100	70-85	15-25	---	NP
	6-60	Loamy fine sand, fine sand, sand.	SM	A-2	0	100	95-100	70-85	15-25	---	NP
140*: Torriorthents											
Rock outcrop											
141*: Torriorthents											
Orthids											
142-----Vint	0-10	Loamy very fine sand.	SM, ML	A-4	0	100	100	85-95	40-65	15-25	NP-5
	10-60	Loamy fine sand	SM	A-2	0	95-100	95-100	70-80	20-30	---	NP
143-----Vint	0-12	Fine sandy loam	ML, CL-ML, SM, SM-SC	A-4	0	100	100	75-85	45-55	15-25	NP-5
	12-60	Loamy sand, loamy fine sand.	SM	A-2	0	95-100	95-100	70-80	20-30	---	NP
144*: Vint-----	0-10	Very fine sandy loam.	SM, ML	A-4	0	100	100	85-95	40-65	15-25	NP-5
	10-40	Loamy fine sand	SM	A-2	0	95-100	95-100	70-80	20-30	---	NP
	40-60	Silty clay-----	CL, CH	A-7	0	100	100	95-100	85-95	40-65	20-35
Indio-----	0-12	Very fine sandy loam.	ML	A-4	0	95-100	95-100	85-100	75-90	20-30	NP-5
	12-40	Stratified loamy very fine sand to silt loam.	ML	A-4	0	95-100	95-100	85-100	75-90	20-30	NP-5
	40-72	Silty clay-----	CL, CH	A-7	0	100	100	95-100	85-95	40-65	20-35

* See description of the map unit for composition and behavior characteristics of the map unit.



Subject Site



GS Lyon

Project No.: GS2011

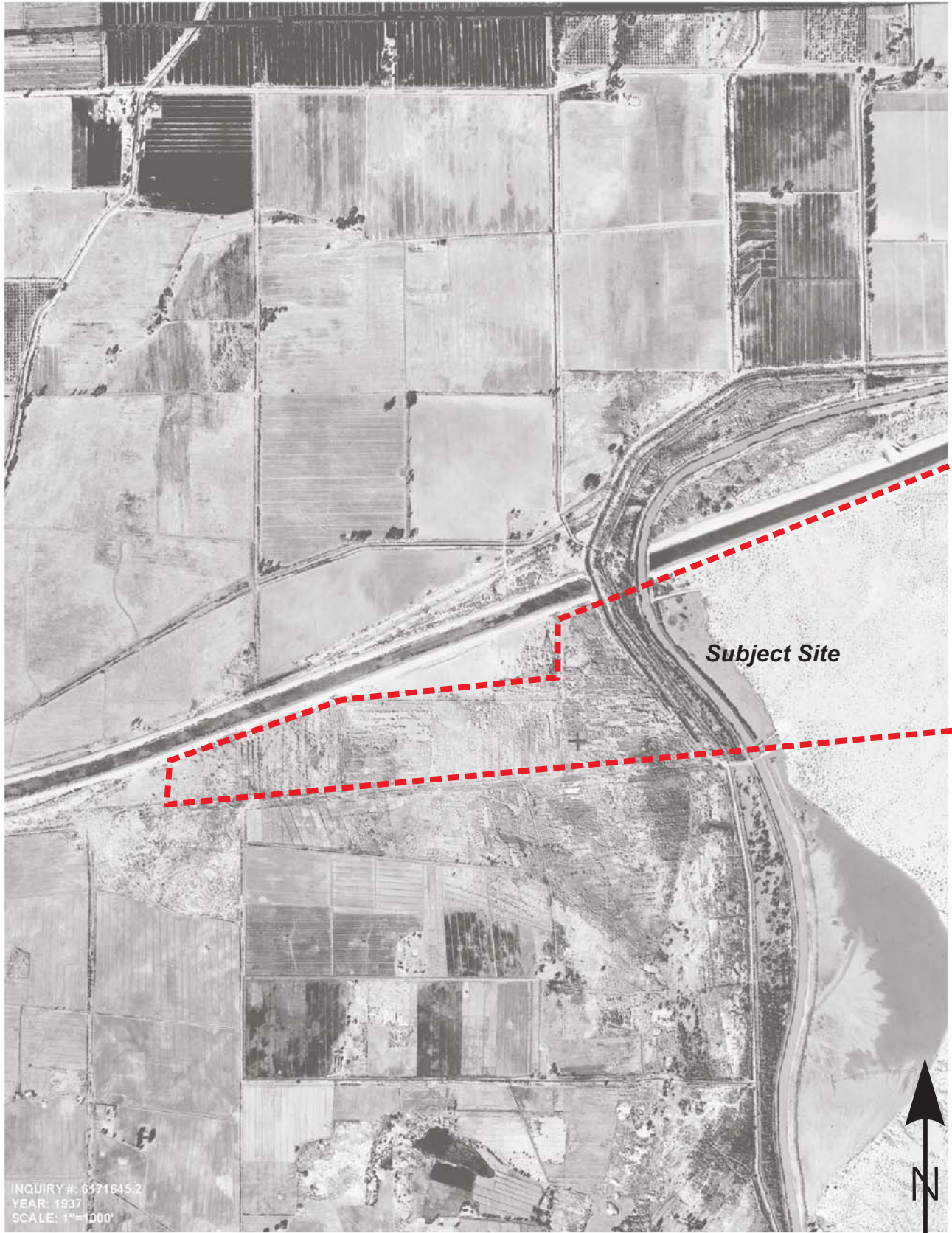
Topographic Map

Plate
4

PC ORIGINAL PKG

APPENDIX C

PC ORIGINAL PKG



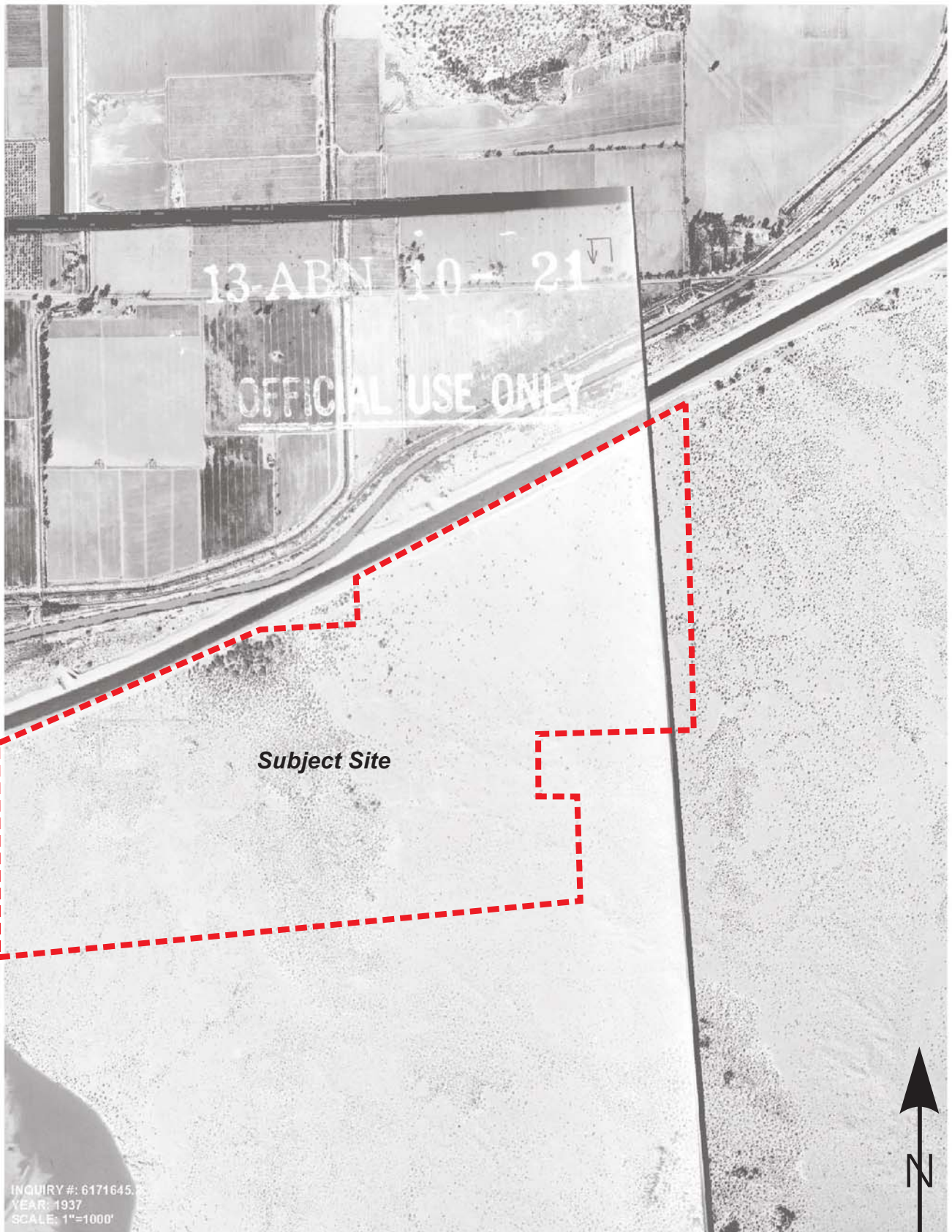
GS Lyon

Project No.: GS2015

1937 Aerial Photograph

Plate
5a

PC ORIGINAL PKG



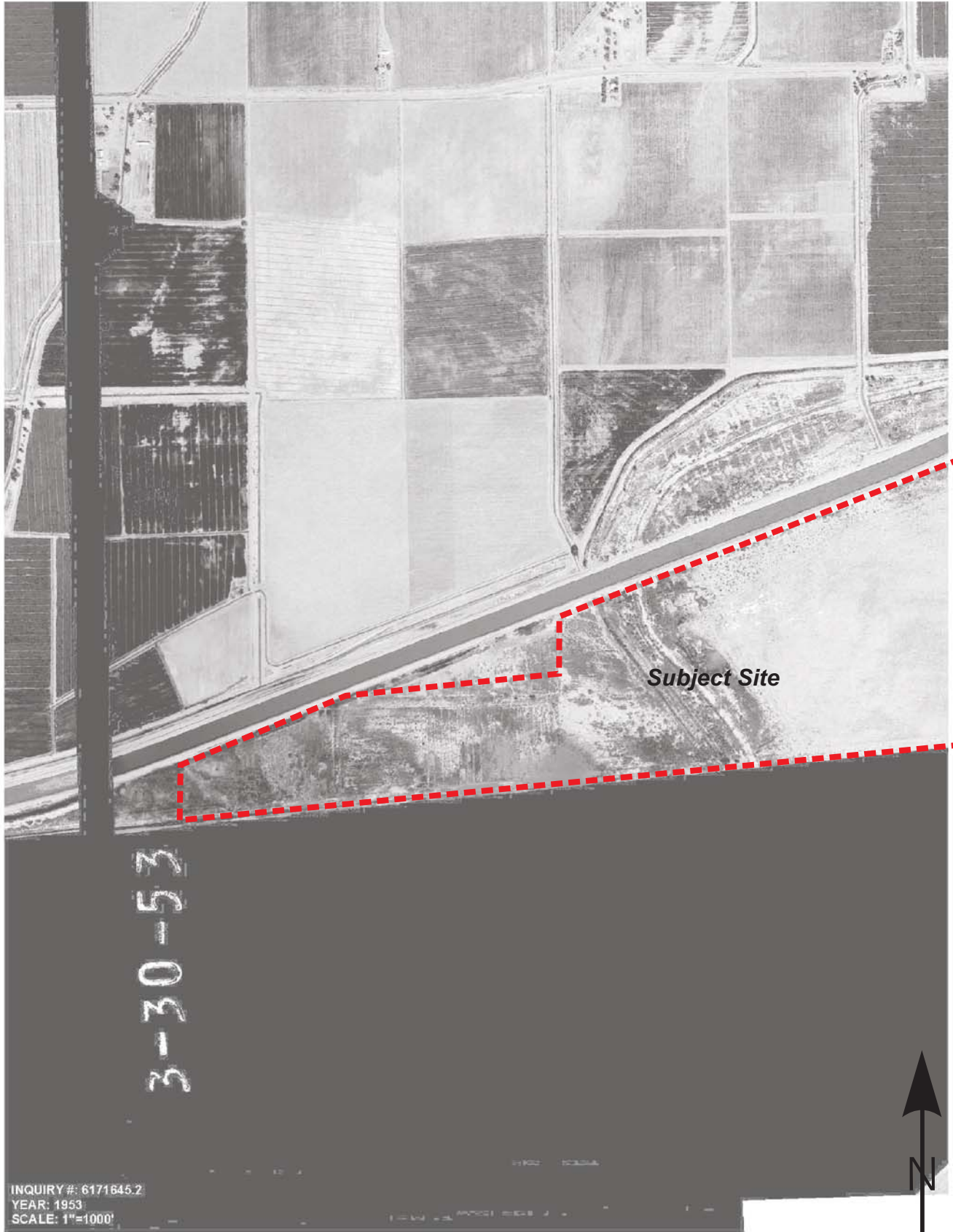
GS Lyon

Project No.: GS2015

1937 Aerial Photograph

Plate
5b

PC ORIGINAL PKG



3-30-53

Subject Site

INQUIRY #: 6171645.2
YEAR: 1953
SCALE: 1"=1000'



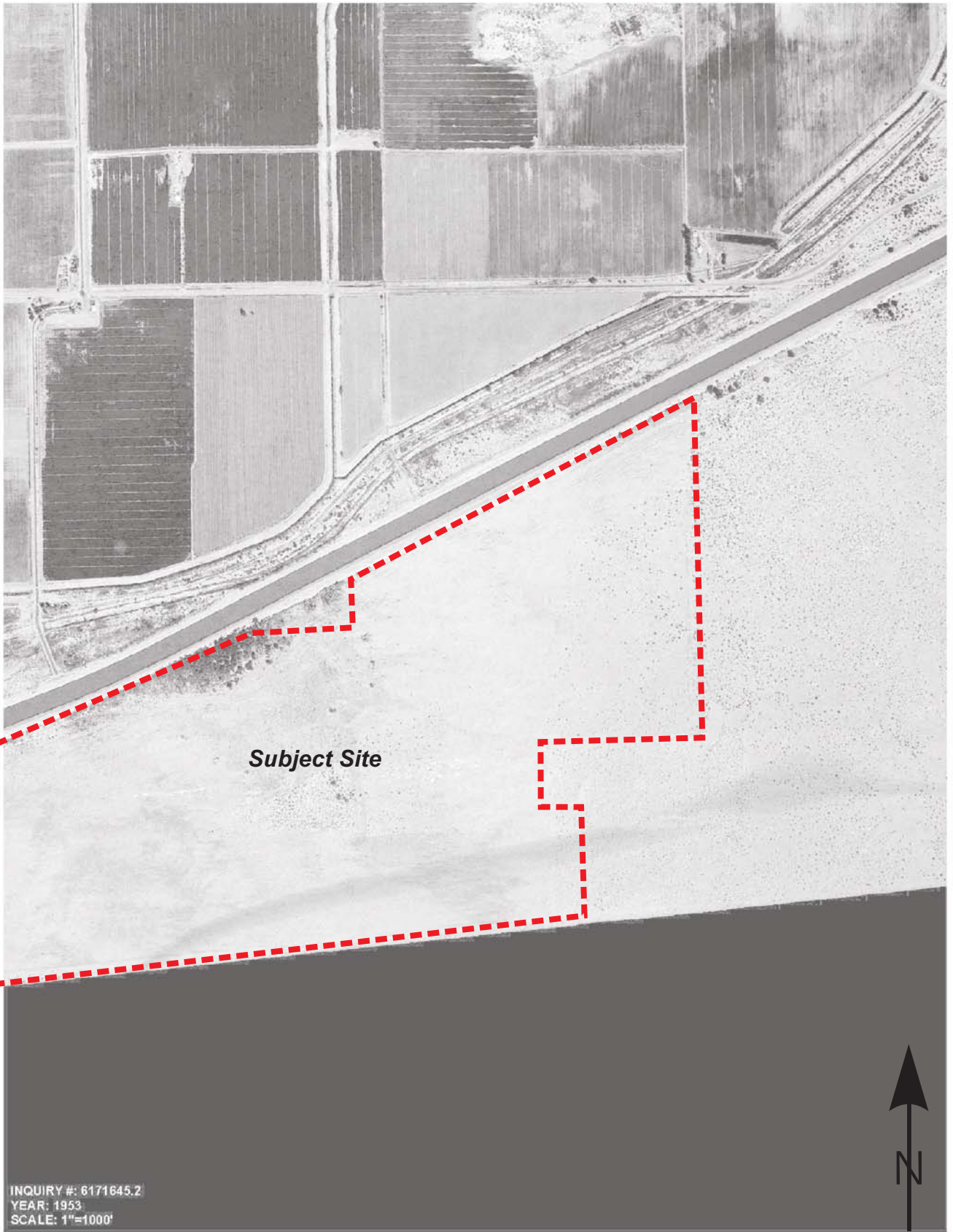
GS Lyon

Project No.: GS2015

1953 Aerial Photograph

Plate
6a

PC ORIGINAL PKG



INQUIRY #: 6171645.2
YEAR: 1953
SCALE: 1"=1000'

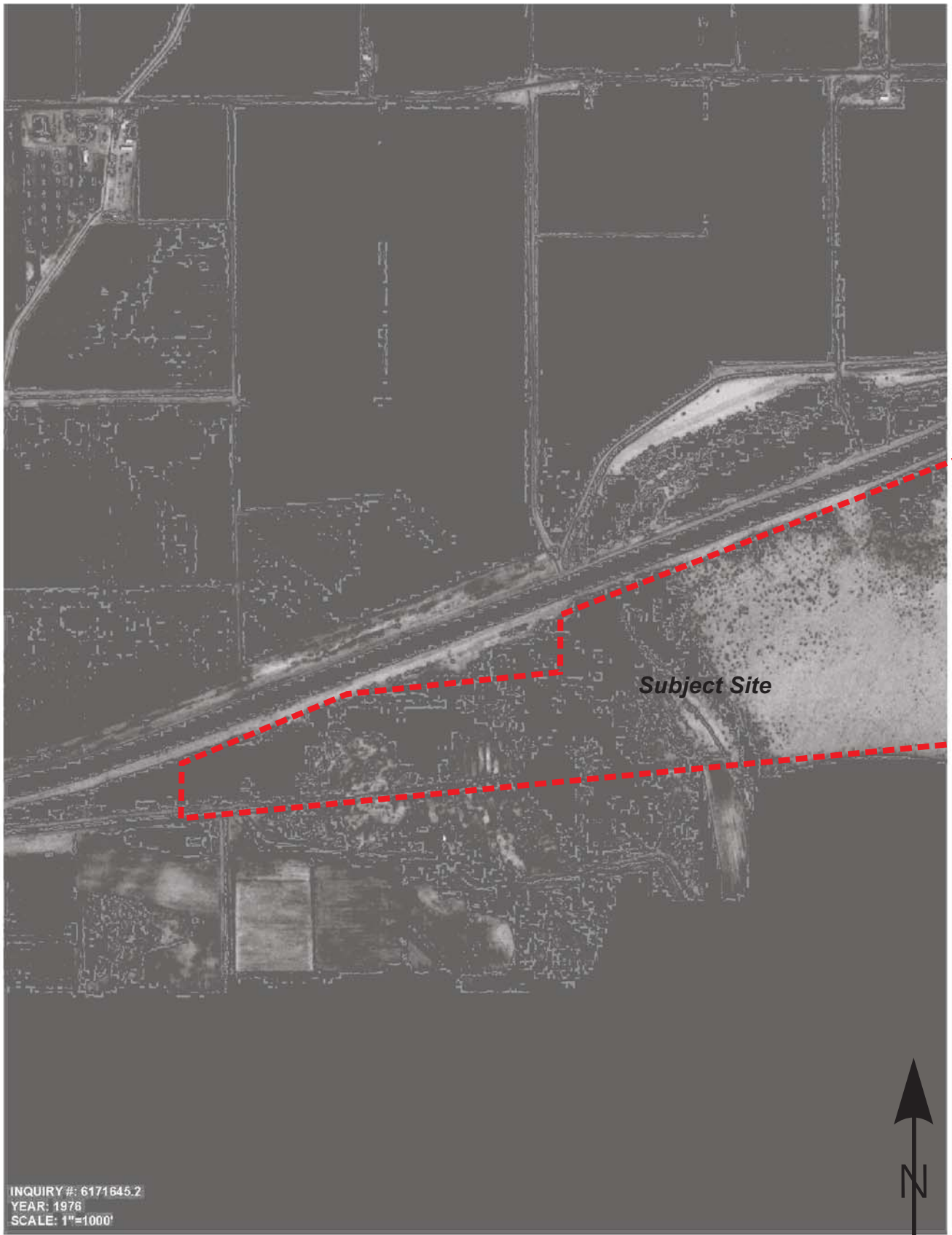


Project No.: GS2015

1953 Aerial Photograph

Plate
6b

PC ORIGINAL PKG



INQUIRY #: 6171645.2
YEAR: 1976
SCALE: 1"=1000'

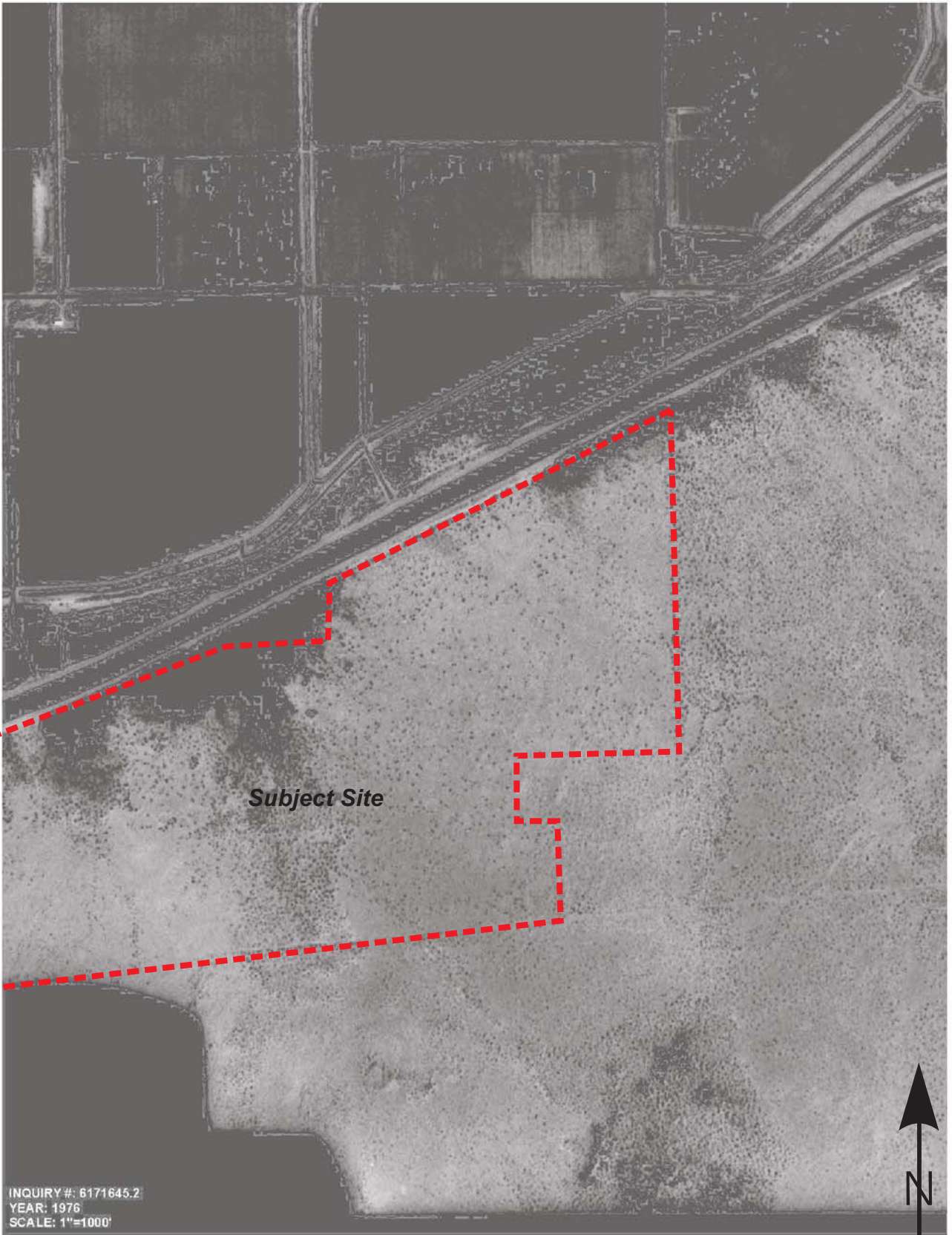
GS Lyon

Project No.: GS2015

1976 Aerial Photograph

Plate
7a

PC ORIGINAL PKG



INQUIRY #: 6171645.2
YEAR: 1976
SCALE: 1"=1000'



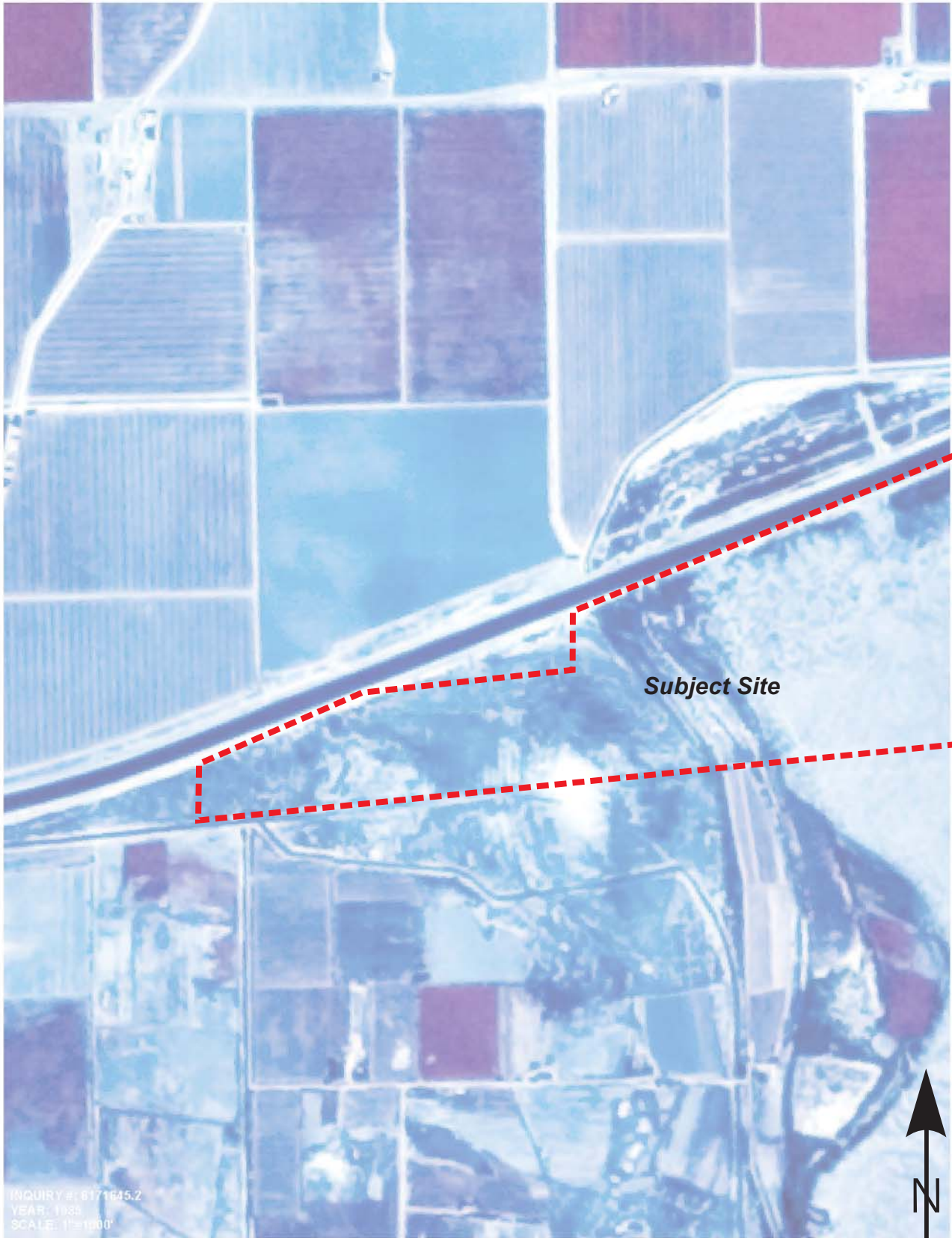
GS Lyon

Project No.: GS2015

1976 Aerial Photograph

Plate
7b

PC ORIGINAL PKG



INQUIRY #: 6171645.2
YEAR: 1985
SCALE: 1"=1000'

Subject Site



GS Lyon

Project No.: GS2015

1985 Aerial Photograph

Plate
8a

PC ORIGINAL PKG



INQUIRY #: 6171645.7
YEAR: 1985
SCALE: 1"=1000'

Subject Site



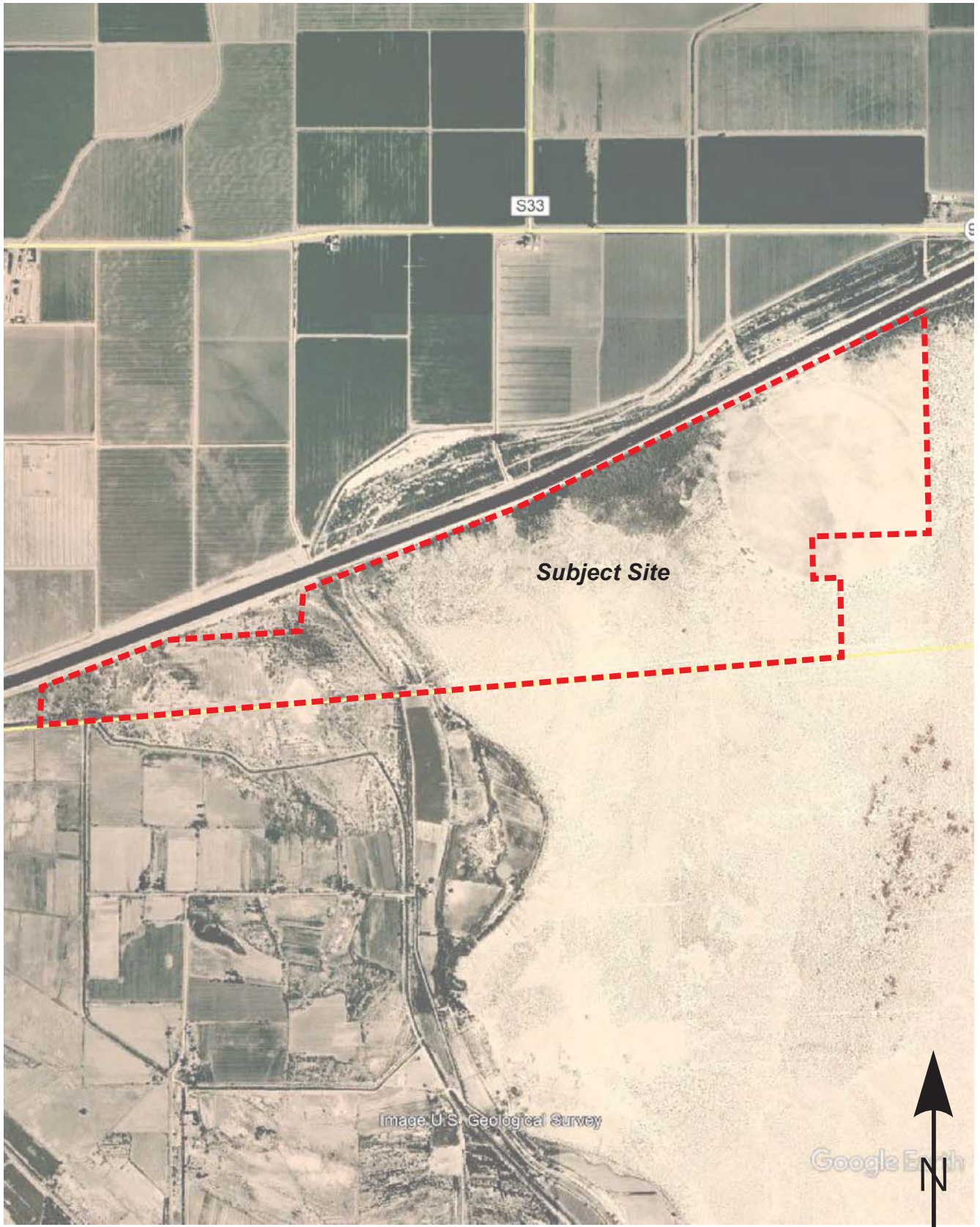
GS Lyon

Project No.: GS2015

1985 Aerial Photograph

Plate
8b

PC ORIGINAL PKG



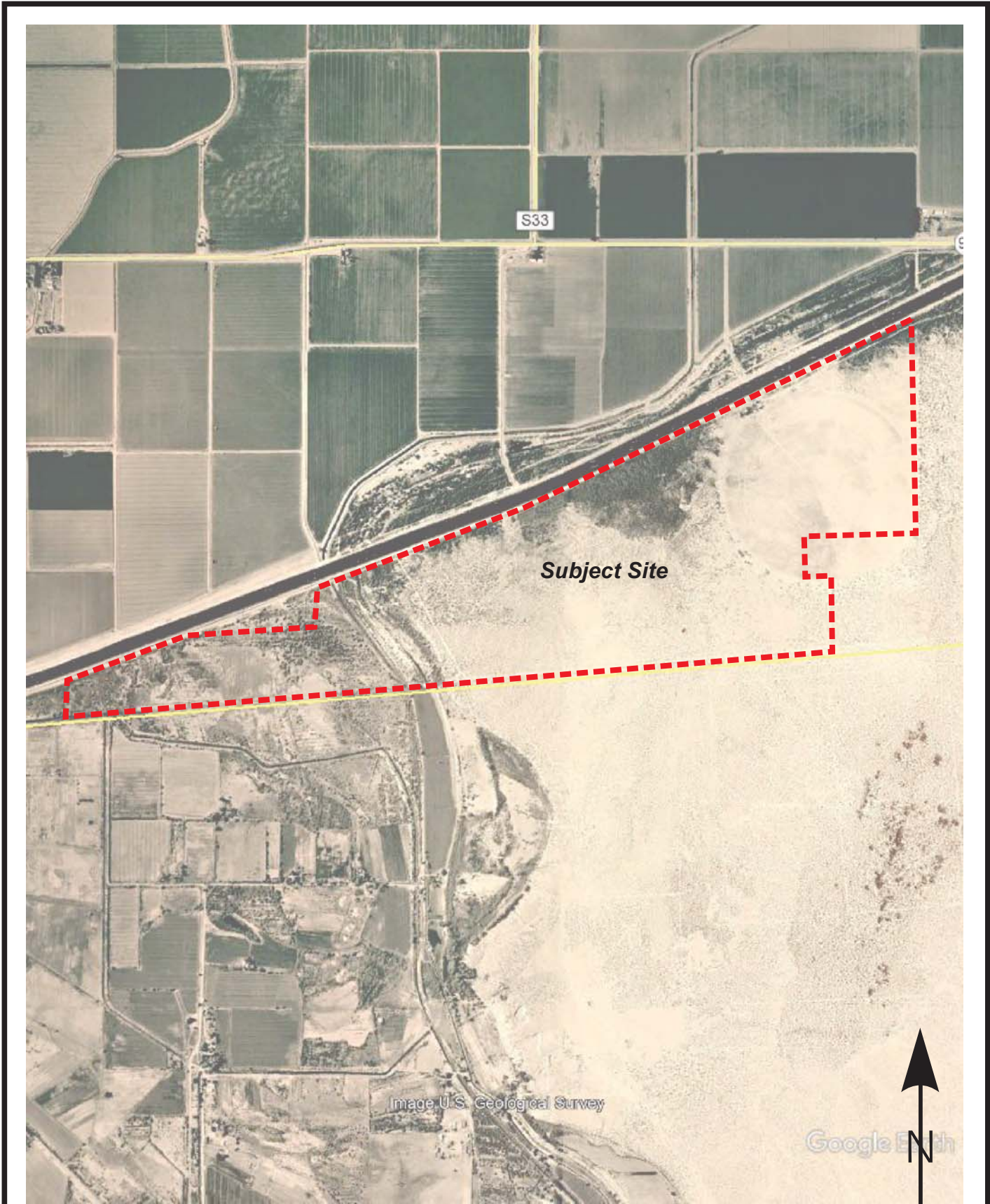
GS Lyon

Project No.: GS2015

1996 Aerial Photograph

Plate
9

PC ORIGINAL PKG



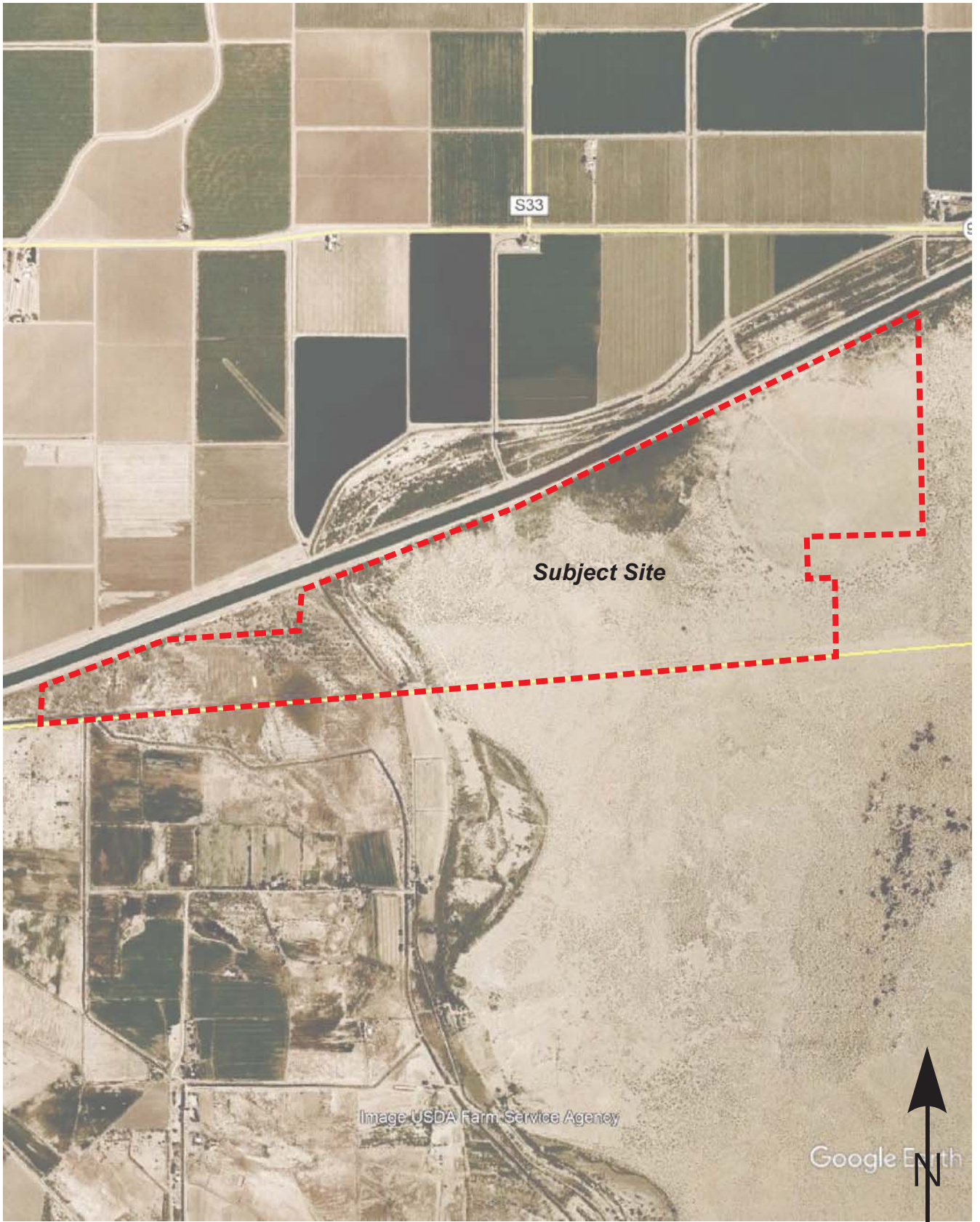
GS Lyon

Project No.: GS2015

2002 Aerial Photograph

Plate
10

PC ORIGINAL PKG



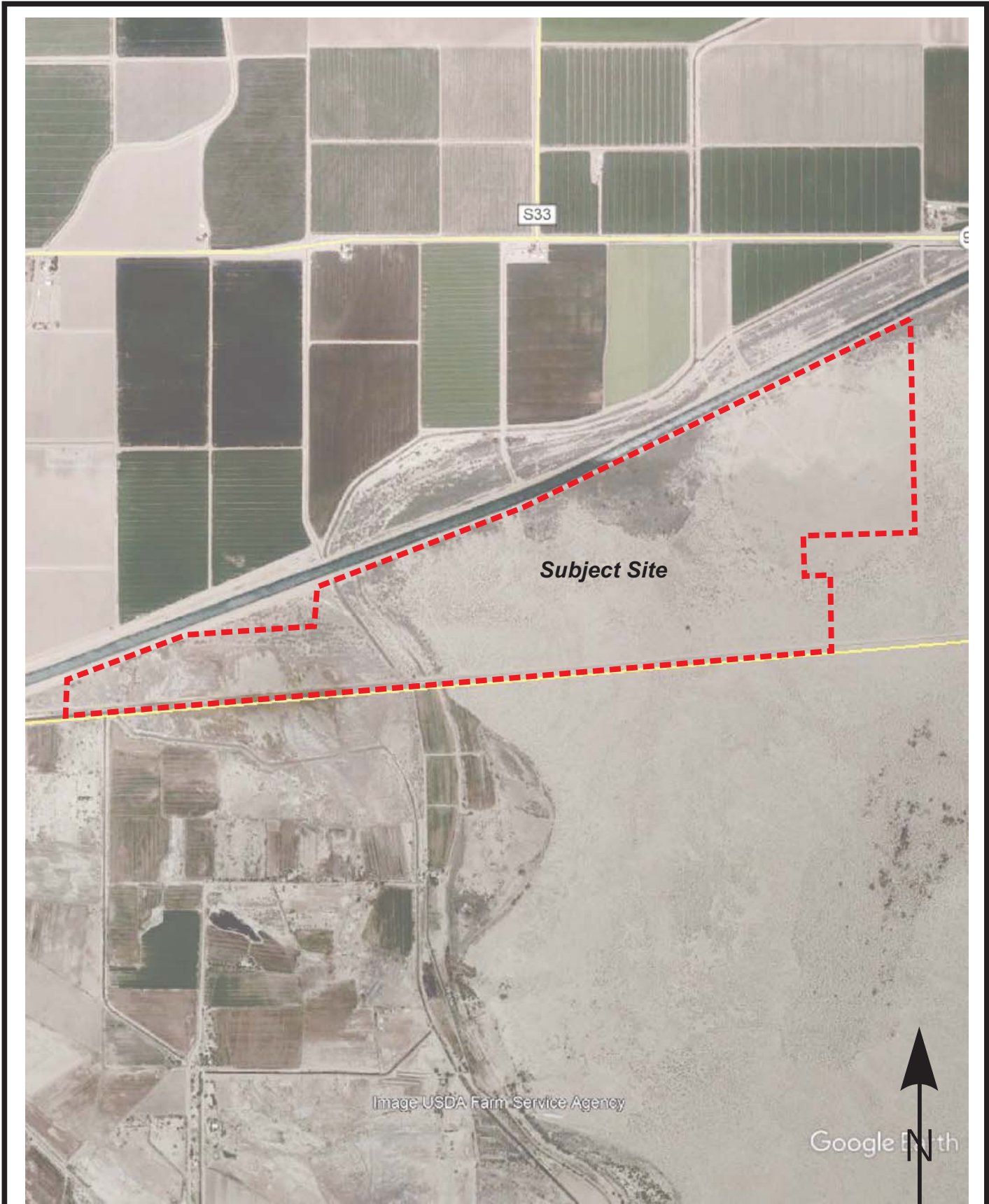
GS Lyon

Project No.: GS2015

2006 Aerial Photograph

Plate
11

PC ORIGINAL PKG



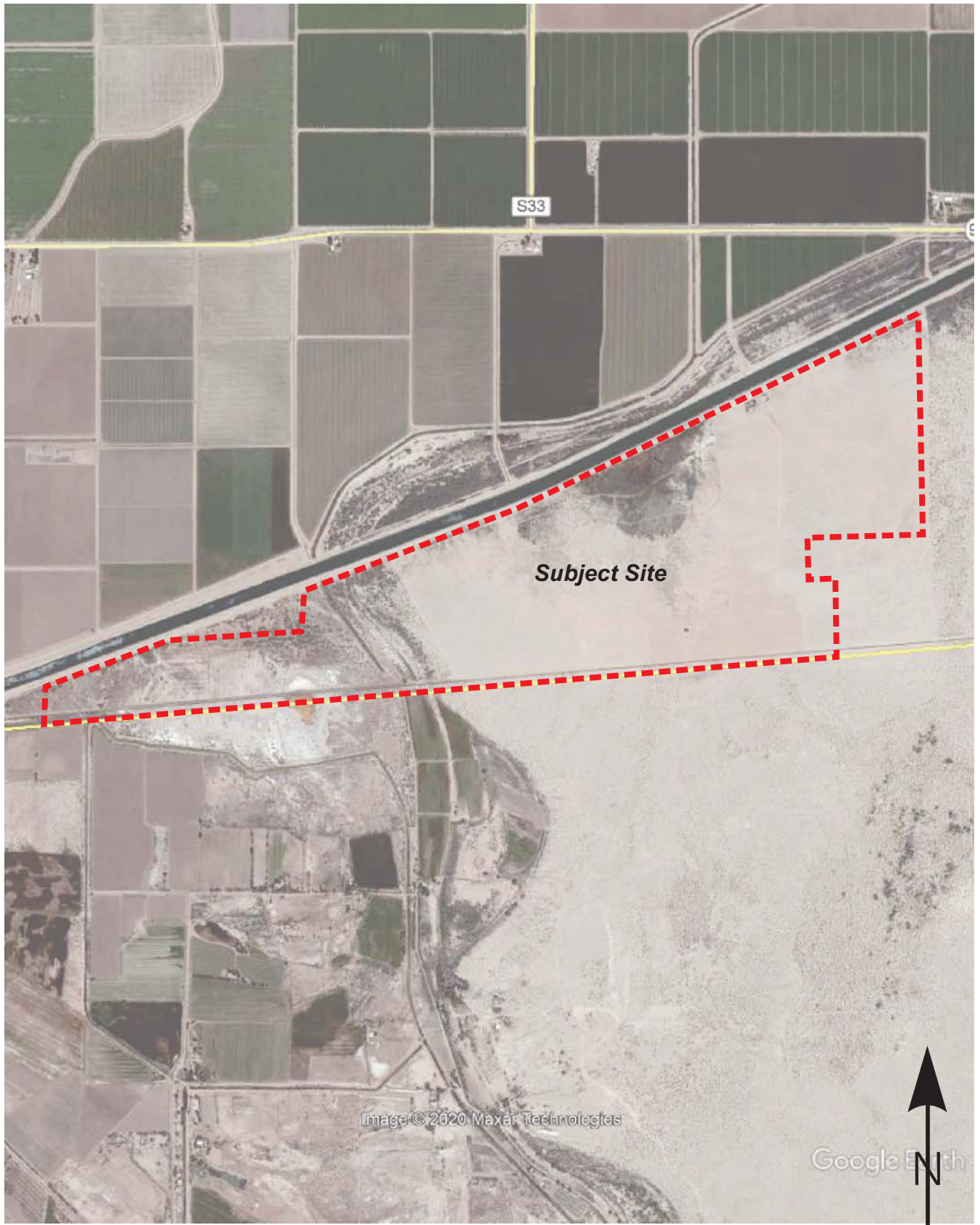
GS Lyon

Project No.: GS2015

2010 Aerial Photograph

Plate
12

PC ORIGINAL PKG



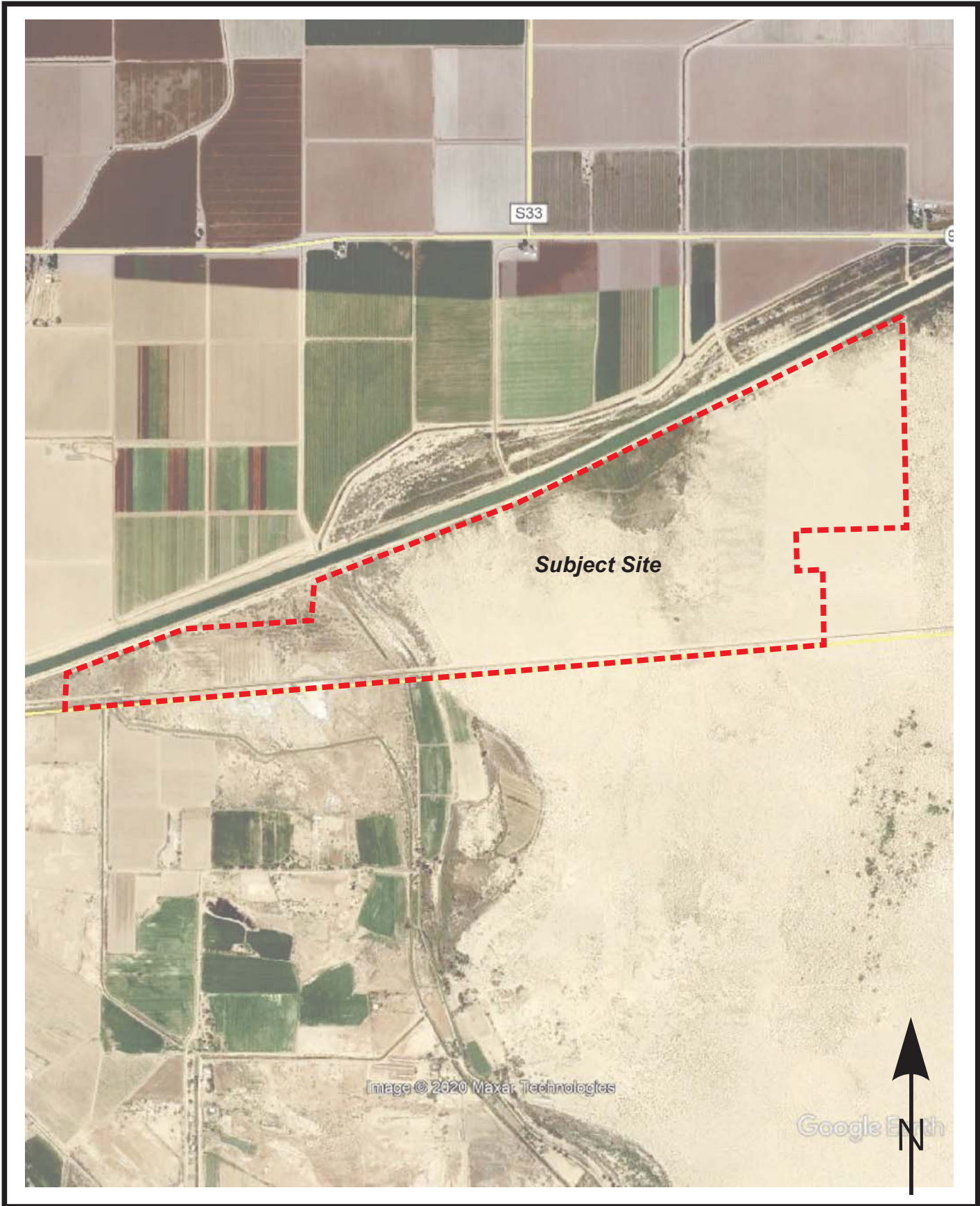
GS Lyon

Project No.: GS2015

2014 Aerial Photograph

Plate
13

PC ORIGINAL PKG



GS Lyon

Project No.: GS2015

2018 Aerial Photograph

Plate
14

PC ORIGINAL PKG

APPENDIX D

PC ORIGINAL PKG

Cedar Solar 1
SEC All American Canal & Bonds Corner
Calexico, CA 92283

Inquiry Number: 6171645.1

August 28, 2020

EDR Historical Topo Map Report

with QuadMatch™



6 Armstrong Road, 4th floor
Shelton, CT 06484
Toll Free: 800.352.0050
www.edrnet.com

PC ORIGINAL PKG

EDR Historical Topo Map Report

08/28/20

Site Name:

Cedar Solar 1
SEC All American Canal & Bor
Calexico, CA 92283
EDR Inquiry # 6171645.1

Client Name:

GS Lyon Consultants
780 N. Fourth Street
El Centro, CA 92243
Contact: Peter E. Labrucherie



EDR Topographic Map Library has been searched by EDR and maps covering the target property location as provided by GS Lyon Consultants were identified for the years listed below. EDR's Historical Topo Map Report is designed to assist professionals in evaluating potential liability on a target property resulting from past activities. EDR's Historical Topo Map Report includes a search of a collection of public and private color historical topographic maps, dating back to the late 1800s.

Search Results:**Coordinates:**

P.O.#	NA	Latitude:	32.682206 32° 40' 56" North
Project:	GS2015	Longitude:	-115.308199 -115° 18' 30" West
		UTM Zone:	Zone 11 North
		UTM X Meters:	658614.82
		UTM Y Meters:	3617321.89
		Elevation:	46.00' above sea level

Maps Provided:

2012
1976
1957
1947
1940
1907

Disclaimer - Copyright and Trademark Notice

This Report contains certain information obtained from a variety of public and other sources reasonably available to Environmental Data Resources, Inc. It cannot be concluded from this Report that coverage information for the target and surrounding properties does not exist from other sources. NO WARRANTY EXPRESSED OR IMPLIED, IS MADE WHATSOEVER IN CONNECTION WITH THIS REPORT. ENVIRONMENTAL DATA RESOURCES, INC. SPECIFICALLY DISCLAIMS THE MAKING OF ANY SUCH WARRANTIES, INCLUDING WITHOUT LIMITATION, MERCHANTABILITY OR FITNESS FOR A PARTICULAR USE OR PURPOSE. ALL RISK IS ASSUMED BY THE USER. IN NO EVENT SHALL ENVIRONMENTAL DATA RESOURCES, INC. BE LIABLE TO ANYONE, WHETHER ARISING OUT OF ERRORS OR OMISSIONS, NEGLIGENCE, ACCIDENT OR ANY OTHER CAUSE, FOR ANY LOSS OF DAMAGE, INCLUDING, WITHOUT LIMITATION, SPECIAL, INCIDENTAL, CONSEQUENTIAL, OR EXEMPLARY DAMAGES. ANY LIABILITY ON THE PART OF ENVIRONMENTAL DATA RESOURCES, INC. IS STRICTLY LIMITED TO A REFUND OF THE AMOUNT PAID FOR THIS REPORT. Purchaser accepts this Report "AS IS". Any analyses, estimates, ratings, environmental risk levels or risk codes provided in this Report are provided for illustrative purposes only, and are not intended to provide, nor should they be interpreted as providing any facts regarding, or prediction or forecast of, any environmental risk for any property. Only a Phase I Environmental Site Assessment performed by an environmental professional can provide information regarding the environmental risk for any property. Additionally, the information provided in this Report is not to be construed as legal advice.

Copyright 2020 by Environmental Data Resources, Inc. All rights reserved. Reproduction in any media or format, in whole or in part, of any report or map of Environmental Data Resources, Inc., or its affiliates, is prohibited without prior written permission.

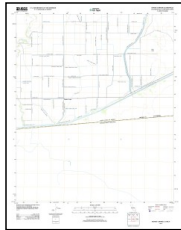
EDR and its logos (including Sanborn and Sanborn Map) are trademarks of Environmental Data Resources, Inc. or its affiliates. All other trademarks used herein are the property of their respective owners.

PC ORIGINAL PKG

Topo Sheet Key

This EDR Topo Map Report is based upon the following USGS topographic map sheets.

2012 Source Sheets



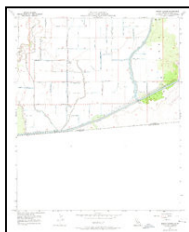
Bonds Corner
2012
7.5-minute, 24000

1976 Source Sheets



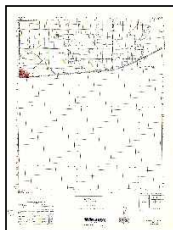
Bonds Corner
1976
7.5-minute, 24000
Aerial Photo Revised 1953

1957 Source Sheets



Bonds Corner
1957
7.5-minute, 24000
Aerial Photo Revised 1953

1947 Source Sheets



CALEXICO
1947
15-minute, 50000

Topo Sheet Key

This EDR Topo Map Report is based upon the following USGS topographic map sheets.

1940 Source Sheets

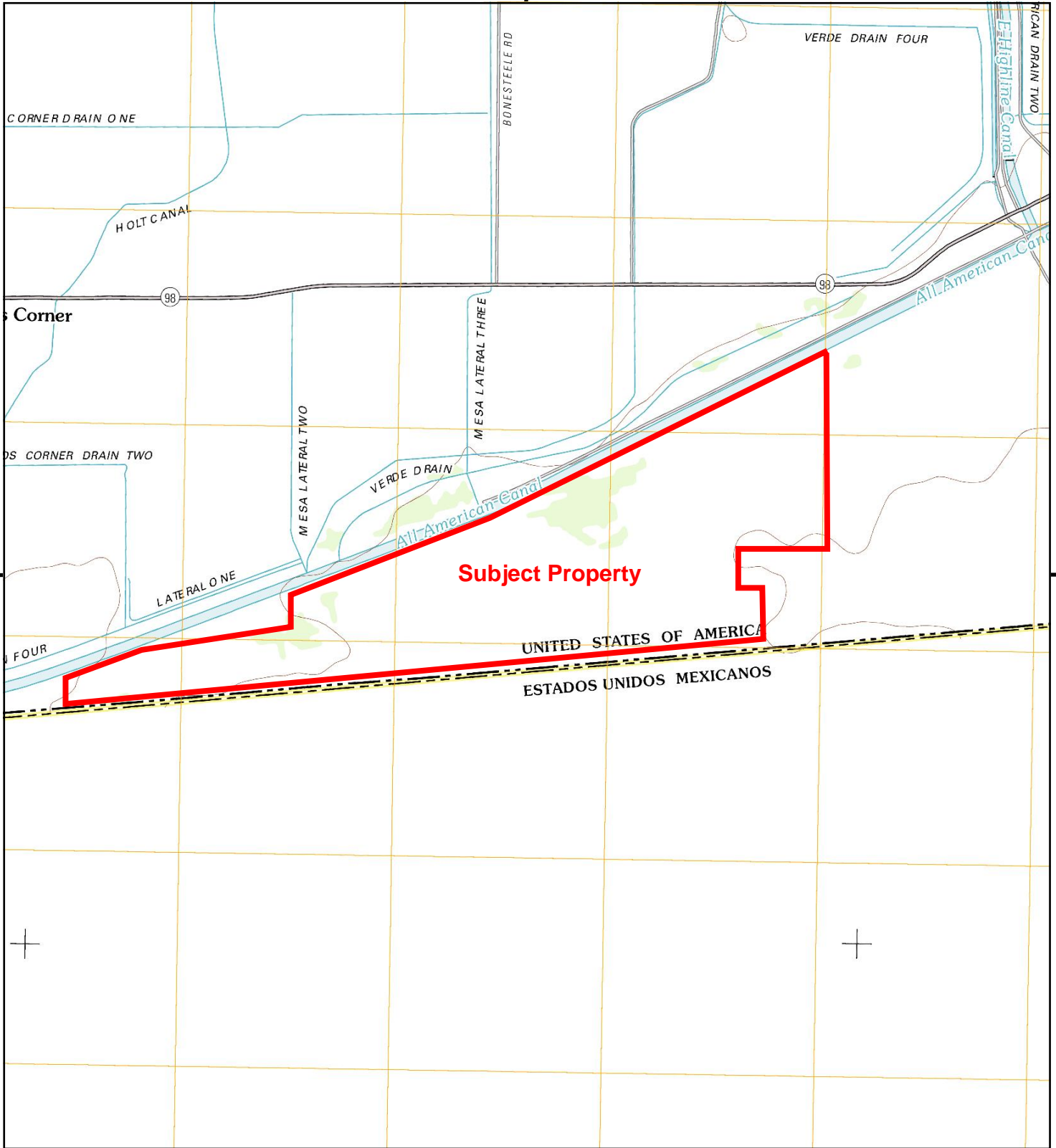


Calexico
1940
15-minute, 62500
Aerial Photo Revised 1940

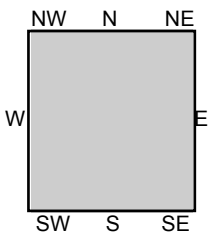
1907 Source Sheets



Holtville
1907
30-minute, 125000



This report includes information from the following map sheet(s).

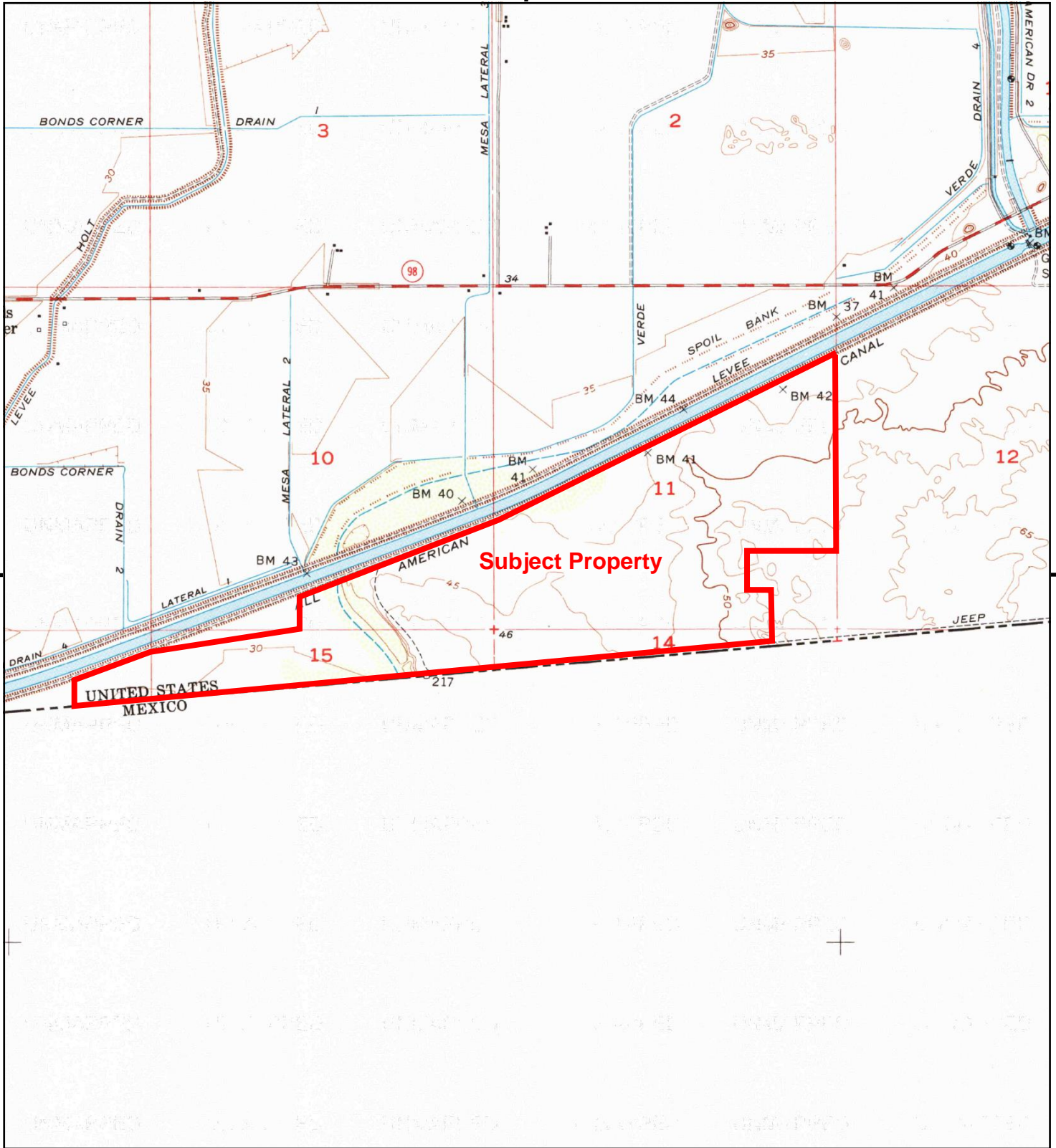


TP, Bonds Corner, 2012, 7.5-minute

SITE NAME: Cedar Solar 1
 ADDRESS: SEC All American Canal & Bonds Corner
 Calexico, CA 92283
 CLIENT: GS Lyon Consultants



PC ORIGINAL PKG



This report includes information from the following map sheet(s).

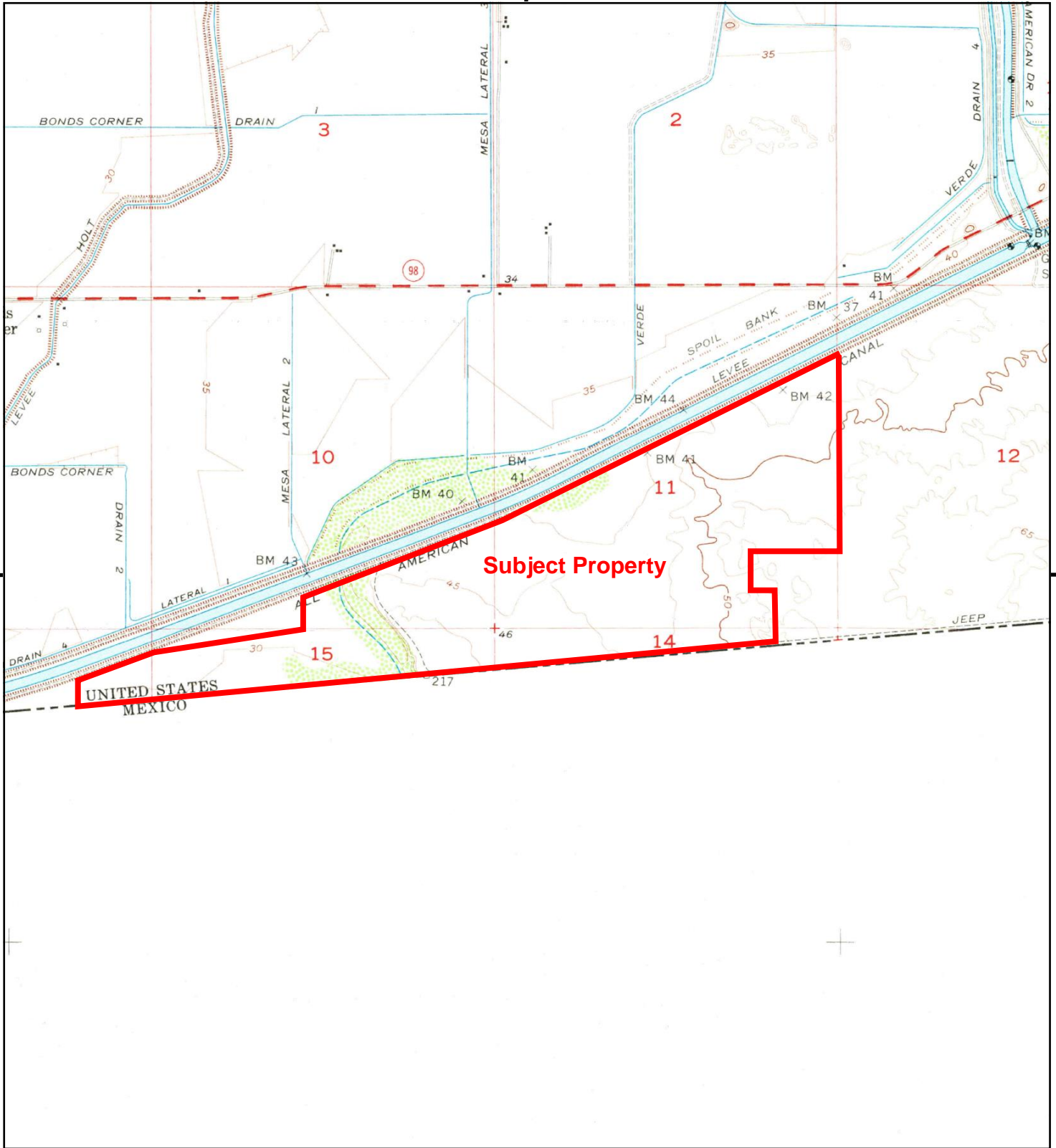


TP, Bonds Corner, 1976, 7.5-minute

SITE NAME: Cedar Solar 1
 ADDRESS: SEC All American Canal & Bonds Corner
 Calexico, CA 92283
 CLIENT: GS Lyon Consultants



PC ORIGINAL PKG



This report includes information from the following map sheet(s).

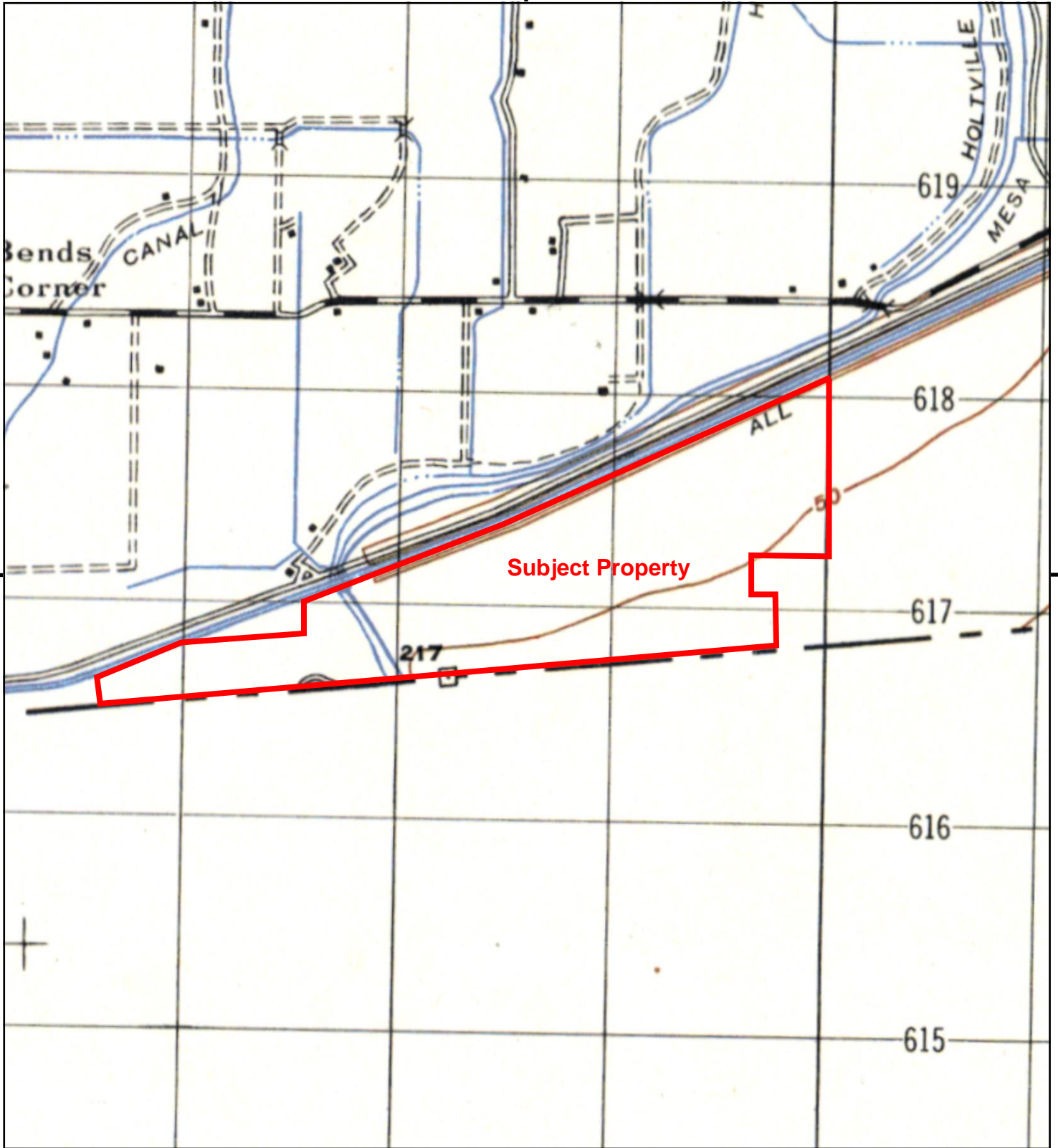


TP, Bonds Corner, 1957, 7.5-minute

SITE NAME: Cedar Solar 1
 ADDRESS: SEC All American Canal & Bonds Corner
 Calexico, CA 92283
 CLIENT: GS Lyon Consultants



PC ORIGINAL PKG



This report includes information from the following map sheet(s).

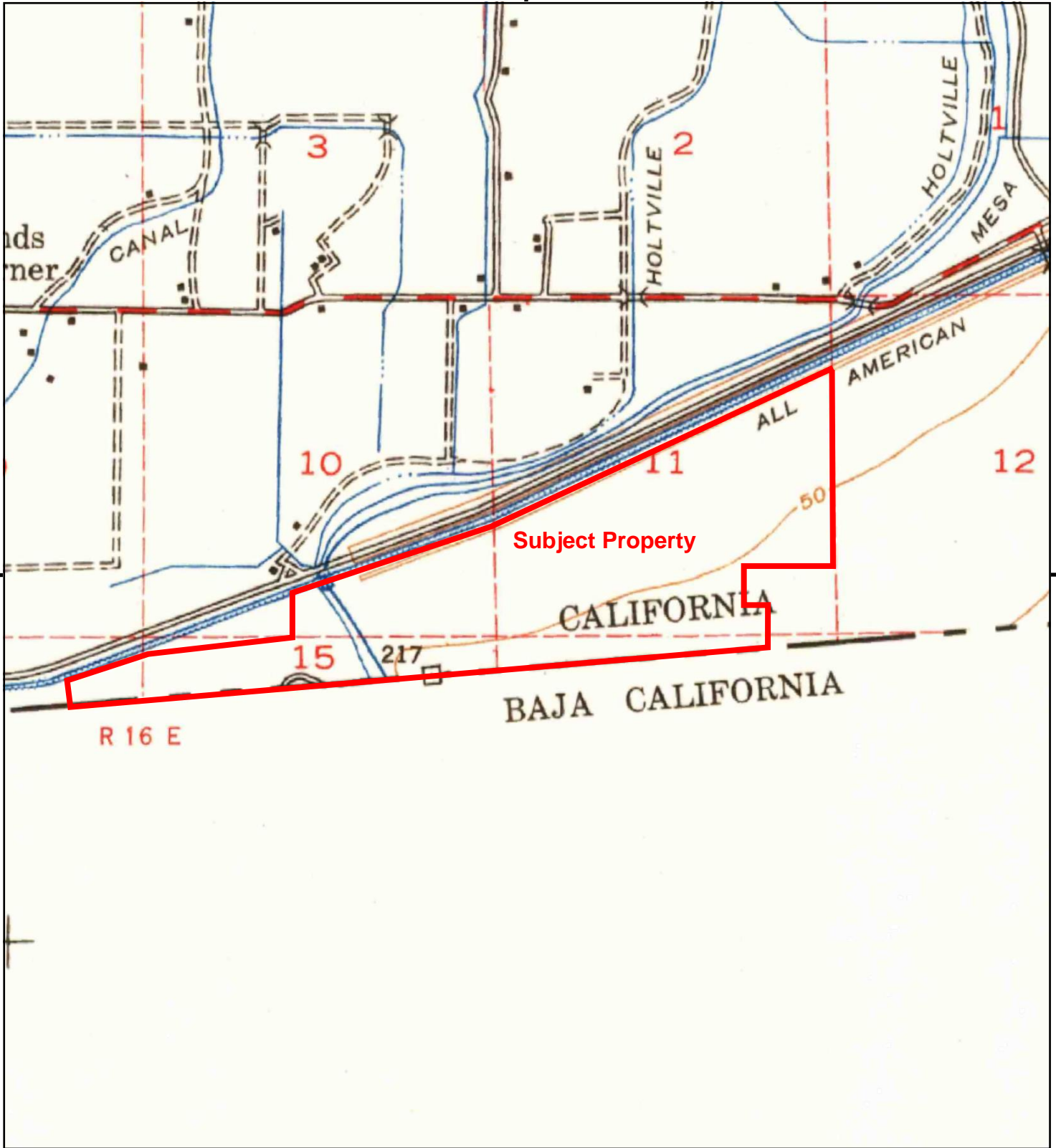


TP, CALEXICO, 1947, 15-minute

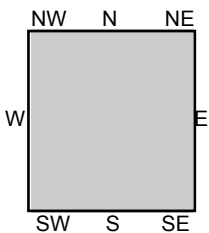
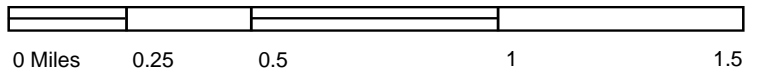
SITE NAME: Cedar Solar 1
 ADDRESS: SEC All American Canal & Bonds Corner
 Calexico, CA 92283
 CLIENT: GS Lyon Consultants



PC ORIGINAL PKG



This report includes information from the following map sheet(s).

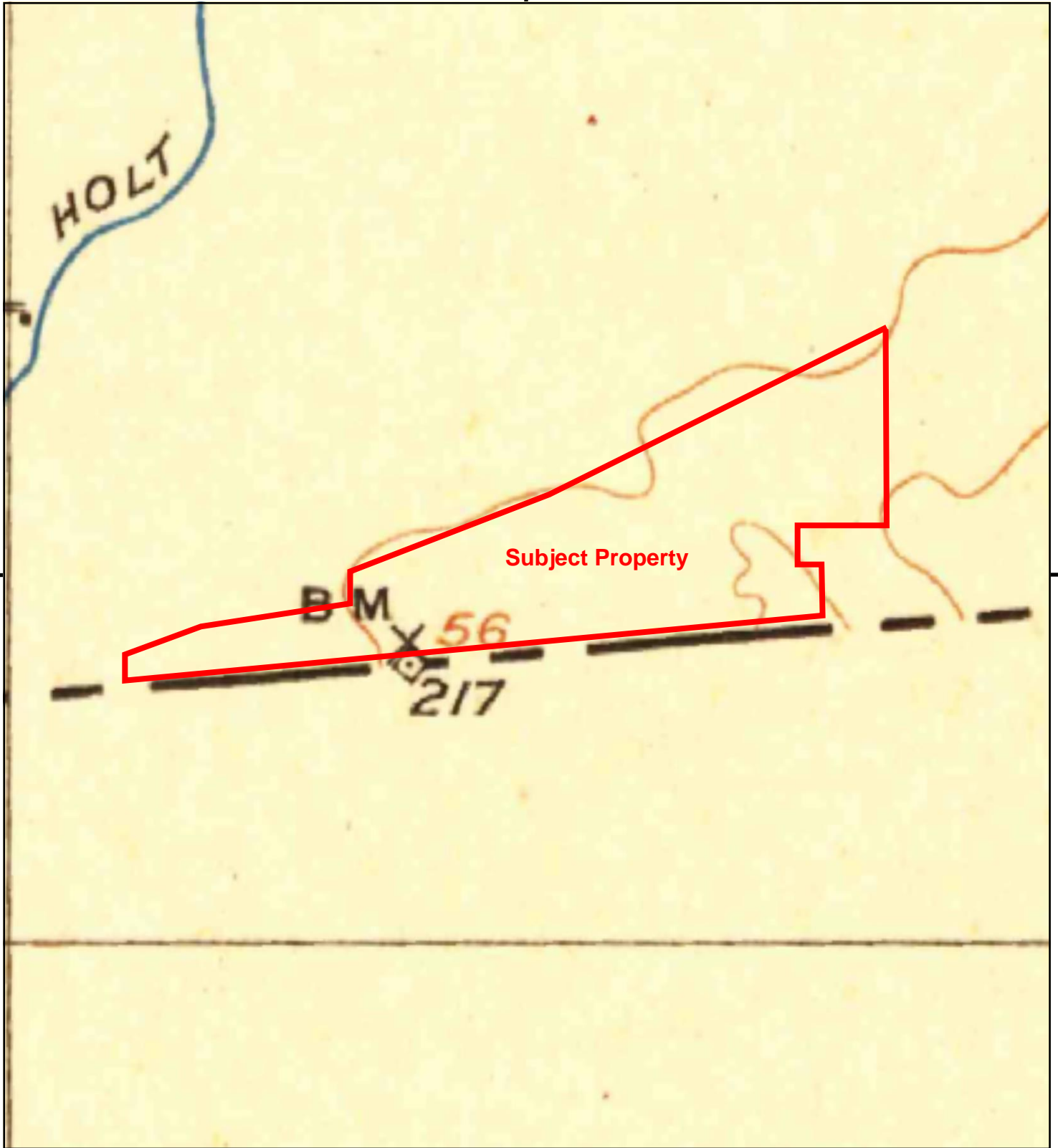


TP, Calexico, 1940, 15-minute

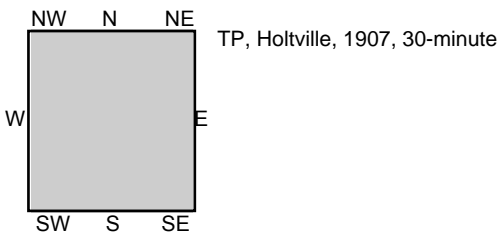
SITE NAME: Cedar Solar 1
 ADDRESS: SEC All American Canal & Bonds Corner
 Calexico, CA 92283
 CLIENT: GS Lyon Consultants



PC ORIGINAL PKG



This report includes information from the following map sheet(s).



SITE NAME: Cedar Solar 1
 ADDRESS: SEC All American Canal & Bonds Corner
 Calexico, CA 92283
 CLIENT: GS Lyon Consultants



PC ORIGINAL PKG

APPENDIX E

PC ORIGINAL PKG

Cedar Solar 1

SEC All American Canal & Bonds Corner
Calexico, CA 92283

Inquiry Number: 6171645.3s
August 27, 2020

EDR Area / Corridor Report



6 Armstrong Road, 4th floor
Shelton, CT 06484
Toll Free: 800.352.0050
www.edrnet.com

PC ORIGINAL PKG

TABLE OF CONTENTS

<u>SECTION</u>	<u>PAGE</u>
Executive Summary	ES1
Mapped Sites Summary	2
Key Map	2
Map Findings Summary	3
Focus Maps	8
Map Findings	20
Orphan Summary	OR-1
Government Records Searched/Data Currency Tracking	GR-1

Thank you for your business.
Please contact EDR at 1-800-352-0050
with any questions or comments.

Disclaimer - Copyright and Trademark Notice

This Report contains certain information obtained from a variety of public and other sources reasonably available to Environmental Data Resources, Inc. It cannot be concluded from this Report that coverage information for the target and surrounding properties does not exist from other sources. **NO WARRANTY EXPRESSED OR IMPLIED, IS MADE WHATSOEVER IN CONNECTION WITH THIS REPORT. ENVIRONMENTAL DATA RESOURCES, INC. SPECIFICALLY DISCLAIMS THE MAKING OF ANY SUCH WARRANTIES, INCLUDING WITHOUT LIMITATION, MERCHANTABILITY OR FITNESS FOR A PARTICULAR USE OR PURPOSE. ALL RISK IS ASSUMED BY THE USER. IN NO EVENT SHALL ENVIRONMENTAL DATA RESOURCES, INC. BE LIABLE TO ANYONE, WHETHER ARISING OUT OF ERRORS OR OMISSIONS, NEGLIGENCE, ACCIDENT OR ANY OTHER CAUSE, FOR ANY LOSS OF DAMAGE, INCLUDING, WITHOUT LIMITATION, SPECIAL, INCIDENTAL, CONSEQUENTIAL, OR EXEMPLARY DAMAGES. ANY LIABILITY ON THE PART OF ENVIRONMENTAL DATA RESOURCES, INC. IS STRICTLY LIMITED TO A REFUND OF THE AMOUNT PAID FOR THIS REPORT.** Purchaser accepts this Report "AS IS". Any analyses, estimates, ratings, environmental risk levels or risk codes provided in this Report are provided for illustrative purposes only, and are not intended to provide, nor should they be interpreted as providing any facts regarding, or prediction or forecast of, any environmental risk for any property. Only a Phase I Environmental Site Assessment performed by an environmental professional can provide information regarding the environmental risk for any property. Additionally, the information provided in this Report is not to be construed as legal advice.

Copyright 2020 by Environmental Data Resources, Inc. All rights reserved. Reproduction in any media or format, in whole or in part, of any report or map of Environmental Data Resources, Inc., or its affiliates, is prohibited without prior written permission.

EDR and its logos (including Sanborn and Sanborn Map) are trademarks of Environmental Data Resources, Inc. or its affiliates. All other trademarks used herein are the property of their respective owners.

EXECUTIVE SUMMARY

A search of available environmental records was conducted by Environmental Data Resources, Inc (EDR). The report was designed to assist parties seeking to meet the search requirements of EPA's Standards and Practices for All Appropriate Inquiries (40 CFR Part 312), the ASTM Standard Practice for Environmental Site Assessments (E 1527-13), the ASTM Standard Practice for Environmental Site Assessments for Forestland or Rural Property (E 2247-16), the ASTM Standard Practice for Limited Environmental Due Diligence: Transaction Screen Process (E 1528-14) or custom requirements developed for the evaluation of environmental risk associated with a parcel of real estate.

SUBJECT PROPERTY INFORMATION

ADDRESS

SEC ALL AMERICAN CANAL & BONDS CORNER
CALEXICO, CA 92283

TARGET PROPERTY SEARCH RESULTS

The Target Property was identified in the following databases.

Page Numbers and Map Identifications refer to the EDR Area/Corridor Report where detailed data on individual sites can be reviewed.

Sites listed in ***bold italics*** are in multiple databases.

SURROUNDING SITES: SEARCH RESULTS

Surrounding sites were not identified.

Unmappable (orphan) sites are not considered in the foregoing analysis.

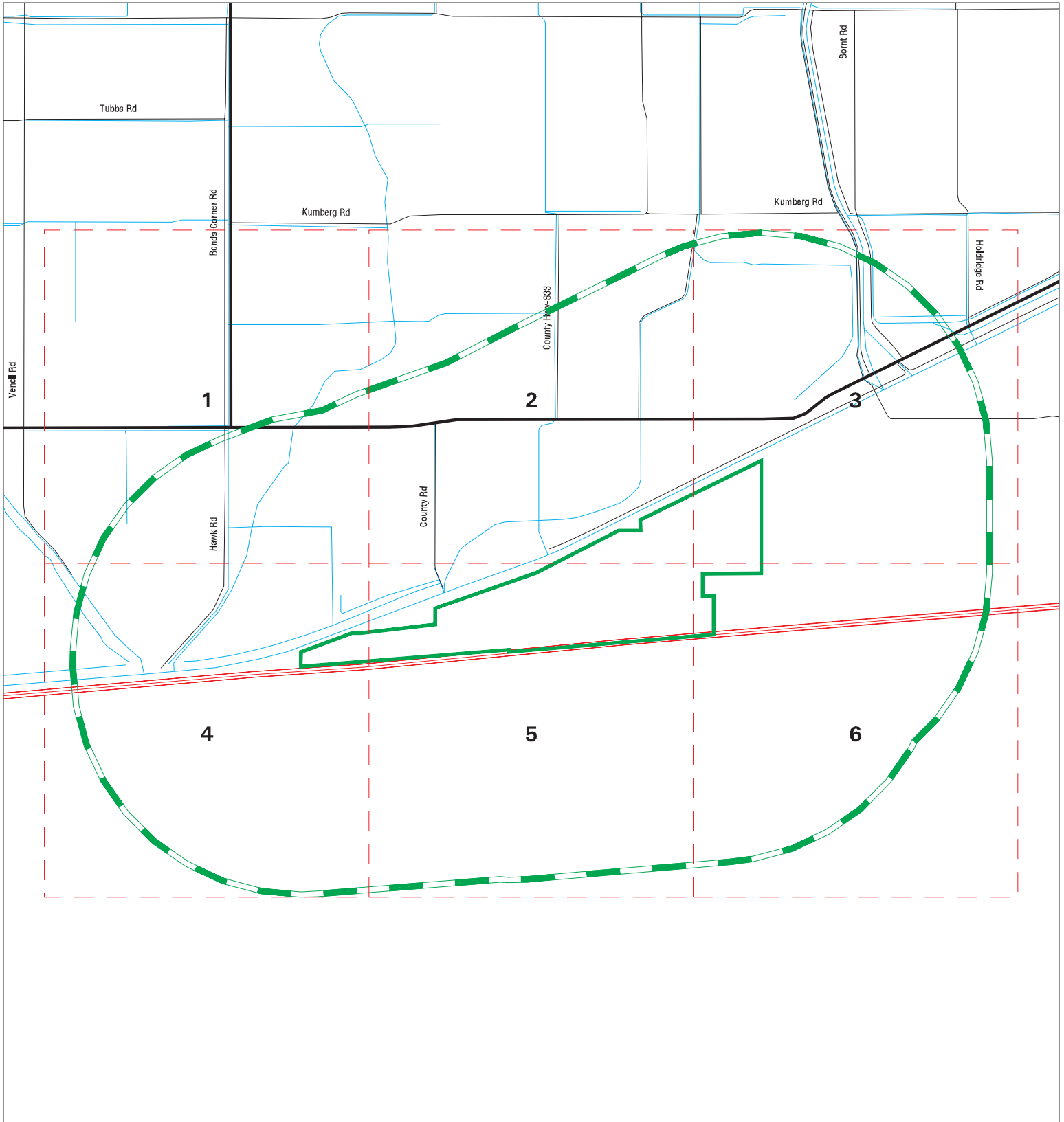
MAPPED SITES SUMMARY

Target Property:
SEC ALL AMERICAN CANAL & BONDS CORNER
CALEXICO, CA 92283

MAP ID / FOCUS MAP	SITE NAME	ADDRESS	DATABASE ACRONYMS	DIST (ft. & mi.) DIRECTION
-----------------------	-----------	---------	-------------------	-------------------------------

NO MAPPED SITES FOUND

Key Map - 6171645.3s



- ▲ Sites
- ↗ Target Property
- ↘ Search Buffer
- ↗ Focus Map - Sites
- National Priority List Sites
- Areas of Concern
- Focus Map - No Sites
- Dept. Defense Sites
- Indian Reservations BIA



SITE NAME: Cedar Solar 1 ADDRESS: SEC All American Canal & Bonds Corner CITY/STATE: Calexico CA ZIP: 92283	CLIENT: GS Lyon Consultants CONTACT: Peter E. Labrucherie INQUIRY #: 6171645.3s DATE: 09/27/20 4:51 PM
---------------------------------------------------------------------------------------------------------------------	----------------------------------------------------------------------------------------------------------------------

PC ORIGINAL PKG

MAP FINDINGS SUMMARY

Database	Search Distance (Miles)	Target Property	< 1/8	1/8 - 1/4	1/4 - 1/2	1/2 - 1	> 1	Total Plotted
<u>STANDARD ENVIRONMENTAL RECORDS</u>								
<i>Federal NPL site list</i>								
NPL	1.000		0	0	0	0	NR	0
Proposed NPL	1.000		0	0	0	0	NR	0
NPL LIENS	1.000		0	0	0	0	NR	0
<i>Federal Delisted NPL site list</i>								
Delisted NPL	1.000		0	0	0	0	NR	0
<i>Federal CERCLIS list</i>								
FEDERAL FACILITY	0.500		0	0	0	NR	NR	0
SEMS	0.500		0	0	0	NR	NR	0
<i>Federal CERCLIS NFRAP site list</i>								
SEMS-ARCHIVE	0.500		0	0	0	NR	NR	0
<i>Federal RCRA CORRACTS facilities list</i>								
CORRACTS	1.000		0	0	0	0	NR	0
<i>Federal RCRA non-CORRACTS TSD facilities list</i>								
RCRA-TSDF	0.500		0	0	0	NR	NR	0
<i>Federal RCRA generators list</i>								
RCRA-LQG	0.250		0	0	NR	NR	NR	0
RCRA-SQG	0.250		0	0	NR	NR	NR	0
RCRA-VSQG	0.250		0	0	NR	NR	NR	0
<i>Federal institutional controls / engineering controls registries</i>								
LUCIS	0.500		0	0	0	NR	NR	0
US ENG CONTROLS	0.500		0	0	0	NR	NR	0
US INST CONTROLS	0.500		0	0	0	NR	NR	0
<i>Federal ERNS list</i>								
ERNS	TP		NR	NR	NR	NR	NR	0
<i>State- and tribal - equivalent NPL RESPONSE</i>								
RESPONSE	1.000		0	0	0	0	NR	0
<i>State- and tribal - equivalent CERCLIS ENVIROSTOR</i>								
ENVIROSTOR	1.000		0	0	0	0	NR	0
<i>State and tribal landfill and/or solid waste disposal site lists</i>								
SWF/LF	0.500		0	0	0	NR	NR	0
<i>State and tribal leaking storage tank lists</i>								
LUST	0.500		0	0	0	NR	NR	0

MAP FINDINGS SUMMARY

Database	Search Distance (Miles)	Target Property	< 1/8	1/8 - 1/4	1/4 - 1/2	1/2 - 1	> 1	Total Plotted
INDIAN LUST	0.500		0	0	0	NR	NR	0
CPS-SLIC	0.500		0	0	0	NR	NR	0
State and tribal registered storage tank lists								
FEMA UST	0.250		0	0	NR	NR	NR	0
UST	0.250		0	0	NR	NR	NR	0
AST	0.250		0	0	NR	NR	NR	0
INDIAN UST	0.250		0	0	NR	NR	NR	0
State and tribal voluntary cleanup sites								
VCP	0.500		0	0	0	NR	NR	0
INDIAN VCP	0.500		0	0	0	NR	NR	0
State and tribal Brownfields sites								
BROWNFIELDS	0.500		0	0	0	NR	NR	0
<u>ADDITIONAL ENVIRONMENTAL RECORDS</u>								
Local Brownfield lists								
US BROWNFIELDS	0.500		0	0	0	NR	NR	0
Local Lists of Landfill / Solid Waste Disposal Sites								
WMUDS/SWAT	0.500		0	0	0	NR	NR	0
SWRCY	0.500		0	0	0	NR	NR	0
HAULERS	TP		NR	NR	NR	NR	NR	0
INDIAN ODI	0.500		0	0	0	NR	NR	0
DEBRIS REGION 9	0.500		0	0	0	NR	NR	0
ODI	0.500		0	0	0	NR	NR	0
IHS OPEN DUMPS	0.500		0	0	0	NR	NR	0
Local Lists of Hazardous waste / Contaminated Sites								
US HIST CDL	TP		NR	NR	NR	NR	NR	0
HIST Cal-Sites	1.000		0	0	0	0	NR	0
SCH	0.250		0	0	NR	NR	NR	0
CDL	TP		NR	NR	NR	NR	NR	0
Toxic Pits	1.000		0	0	0	0	NR	0
CERS HAZ WASTE	0.250		0	0	NR	NR	NR	0
US CDL	TP		NR	NR	NR	NR	NR	0
PFAS	0.500		0	0	0	NR	NR	0
Local Lists of Registered Storage Tanks								
SWEEPS UST	0.250		0	0	NR	NR	NR	0
HIST UST	0.250		0	0	NR	NR	NR	0
CERS TANKS	0.250		0	0	NR	NR	NR	0
CA FID UST	0.250		0	0	NR	NR	NR	0
Local Land Records								
LIENS	TP		NR	NR	NR	NR	NR	0

MAP FINDINGS SUMMARY

Database	Search Distance (Miles)	Target Property	< 1/8	1/8 - 1/4	1/4 - 1/2	1/2 - 1	> 1	Total Plotted
LIENS 2	TP		NR	NR	NR	NR	NR	0
DEED	0.500		0	0	0	NR	NR	0
Records of Emergency Release Reports								
HMIRS	TP		NR	NR	NR	NR	NR	0
CHMIRS	TP		NR	NR	NR	NR	NR	0
LDS	TP		NR	NR	NR	NR	NR	0
MCS	TP		NR	NR	NR	NR	NR	0
SPILLS 90	TP		NR	NR	NR	NR	NR	0
Other Ascertainable Records								
RCRA NonGen / NLR	0.250		0	0	NR	NR	NR	0
FUDS	1.000		0	0	0	0	NR	0
DOD	1.000		0	0	0	0	NR	0
SCRD DRYCLEANERS	0.500		0	0	0	NR	NR	0
US FIN ASSUR	TP		NR	NR	NR	NR	NR	0
EPA WATCH LIST	TP		NR	NR	NR	NR	NR	0
2020 COR ACTION	0.250		0	0	NR	NR	NR	0
TSCA	TP		NR	NR	NR	NR	NR	0
TRIS	TP		NR	NR	NR	NR	NR	0
SSTS	TP		NR	NR	NR	NR	NR	0
ROD	1.000		0	0	0	0	NR	0
RMP	TP		NR	NR	NR	NR	NR	0
RAATS	TP		NR	NR	NR	NR	NR	0
PRP	TP		NR	NR	NR	NR	NR	0
PADS	TP		NR	NR	NR	NR	NR	0
ICIS	TP		NR	NR	NR	NR	NR	0
FTTS	TP		NR	NR	NR	NR	NR	0
MLTS	TP		NR	NR	NR	NR	NR	0
COAL ASH DOE	TP		NR	NR	NR	NR	NR	0
COAL ASH EPA	0.500		0	0	0	NR	NR	0
PCB TRANSFORMER	TP		NR	NR	NR	NR	NR	0
RADINFO	TP		NR	NR	NR	NR	NR	0
HIST FTTS	TP		NR	NR	NR	NR	NR	0
DOT OPS	TP		NR	NR	NR	NR	NR	0
CONSENT	1.000		0	0	0	0	NR	0
INDIAN RESERV	1.000		0	0	0	0	NR	0
FUSRAP	1.000		0	0	0	0	NR	0
UMTRA	0.500		0	0	0	NR	NR	0
LEAD SMELTERS	TP		NR	NR	NR	NR	NR	0
US AIRS	TP		NR	NR	NR	NR	NR	0
US MINES	0.250		0	0	NR	NR	NR	0
ABANDONED MINES	0.250		0	0	NR	NR	NR	0
FINDS	TP		NR	NR	NR	NR	NR	0
DOCKET HWC	TP		NR	NR	NR	NR	NR	0
ECHO	TP		NR	NR	NR	NR	NR	0
UXO	1.000		0	0	0	0	NR	0
FUELS PROGRAM	0.250		0	0	NR	NR	NR	0
CA BOND EXP. PLAN	1.000		0	0	0	0	NR	0
Cortese	0.500		0	0	0	NR	NR	0
CUPA Listings	0.250		0	0	NR	NR	NR	0

MAP FINDINGS SUMMARY

Database	Search Distance (Miles)	Target Property	< 1/8	1/8 - 1/4	1/4 - 1/2	1/2 - 1	> 1	Total Plotted
CUPA Listings	0.250		0	0	NR	NR	NR	0
DRYCLEANERS	0.250		0	0	NR	NR	NR	0
EMI	TP		NR	NR	NR	NR	NR	0
ENF	TP		NR	NR	NR	NR	NR	0
Financial Assurance	TP		NR	NR	NR	NR	NR	0
HAZNET	TP		NR	NR	NR	NR	NR	0
ICE	TP		NR	NR	NR	NR	NR	0
HIST CORTESE	0.500		0	0	0	NR	NR	0
HWP	1.000		0	0	0	0	NR	0
HWT	0.250		0	0	NR	NR	NR	0
MINES	0.250		0	0	NR	NR	NR	0
MWMP	0.250		0	0	NR	NR	NR	0
NPDES	TP		NR	NR	NR	NR	NR	0
PEST LIC	TP		NR	NR	NR	NR	NR	0
PROC	0.500		0	0	0	NR	NR	0
Notify 65	1.000		0	0	0	0	NR	0
UIC	TP		NR	NR	NR	NR	NR	0
UIC GEO	TP		NR	NR	NR	NR	NR	0
WASTEWATER PITS	0.500		0	0	0	NR	NR	0
WDS	TP		NR	NR	NR	NR	NR	0
WIP	0.250		0	0	NR	NR	NR	0
MILITARY PRIV SITES PROJECT	TP		NR	NR	NR	NR	NR	0
WDR	TP		NR	NR	NR	NR	NR	0
CIWQS	TP		NR	NR	NR	NR	NR	0
CERS	TP		NR	NR	NR	NR	NR	0
NON-CASE INFO	TP		NR	NR	NR	NR	NR	0
OTHER OIL GAS	TP		NR	NR	NR	NR	NR	0
PROD WATER PONDS	TP		NR	NR	NR	NR	NR	0
SAMPLING POINT	TP		NR	NR	NR	NR	NR	0
WELL STIM PROJ	TP		NR	NR	NR	NR	NR	0
HWTS	TP		NR	NR	NR	NR	NR	0
MINES MRDS	TP		NR	NR	NR	NR	NR	0

EDR HIGH RISK HISTORICAL RECORDS

EDR Exclusive Records

EDR MGP	1.000		0	0	0	0	NR	0
EDR Hist Auto	0.125		0	NR	NR	NR	NR	0
EDR Hist Cleaner	0.125		0	NR	NR	NR	NR	0

EDR RECOVERED GOVERNMENT ARCHIVES

Exclusive Recovered Govt. Archives

RGA LF	TP		NR	NR	NR	NR	NR	0
RGA LUST	TP		NR	NR	NR	NR	NR	0

- Totals -- 0 0 0 0 0 0 0 0

MAP FINDINGS SUMMARY

<u>Database</u>	<u>Search Distance (Miles)</u>	<u>Target Property</u>	<u>< 1/8</u>	<u>1/8 - 1/4</u>	<u>1/4 - 1/2</u>	<u>1/2 - 1</u>	<u>> 1</u>	<u>Total Plotted</u>
-----------------	----------------------------------------	----------------------------	-----------------	------------------	------------------	----------------	---------------	--------------------------

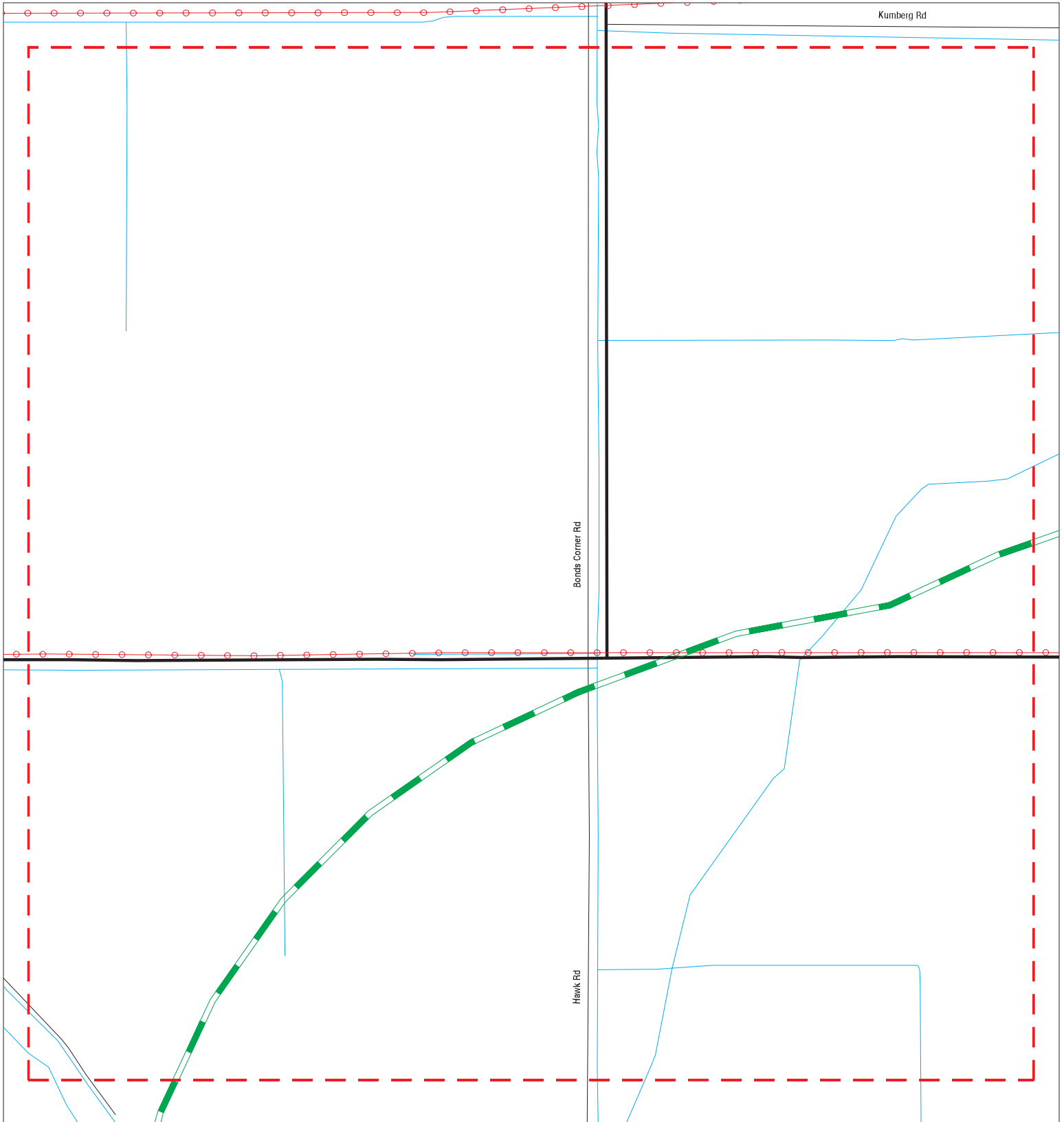
NOTES:











TP = Target Property

NR = Not Requested at this Search Distance

Sites may be listed in more than one database

Focus Map - 1 - 6171645.3s



- | | | |
|---------------------------------------------------------------------------------------------------------|------------------------------------------------------------------------------------------------------------------|-------------------------------------------------------------------------------------------------------------|
|  Sites |  Focus Map - Sites |  Dept. Defense Sites |
|  Target Property |  Power Line |  Indian Reservations BIA |
|  Search Buffer |  National Priority List Sites |  Areas of Concern |
|  Focus Map - No Sites | | |



SITE NAME: Cedar Solar 1
ADDRESS: SEC All American Canal & Bonds Corner
CITY/STATE: Calexico CA
ZIP: 92283

CLIENT: GS Lyon Consultants
CONTACT: Peter E. Labrucherie
INQUIRY #: 6171645.3s
DATE: 09/27/20

PC ORIGINAL PKG

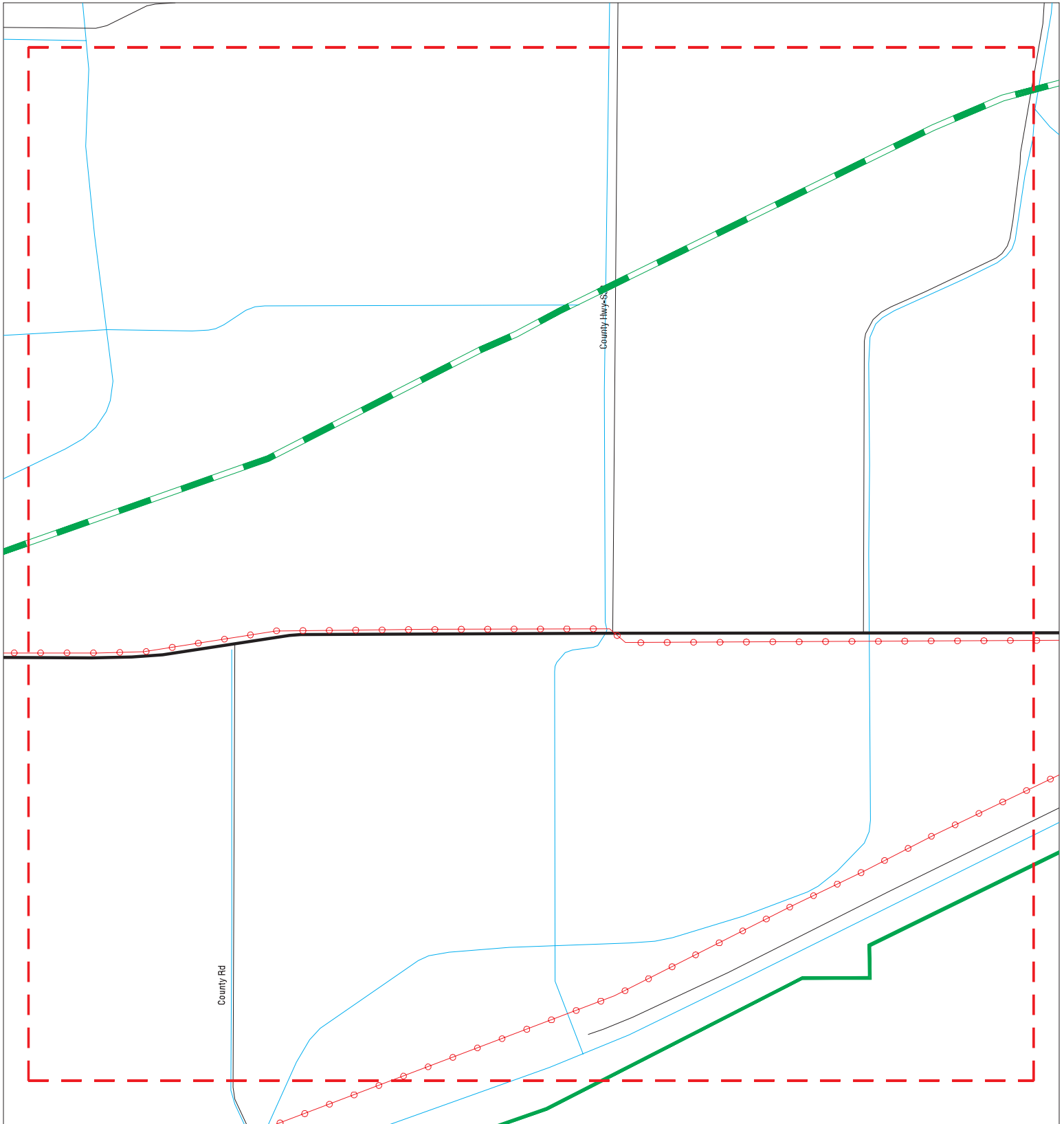
MAPPED SITES SUMMARY - FOCUS MAP 1











Target Property:
SEC ALL AMERICAN CANAL & BONDS CORNER
CALEXICO, CA 92283

MAP ID / FOCUS MAP	SITE NAME	ADDRESS	DATABASE ACRONYMS	DIST (ft. & mi.) DIRECTION
-----------------------	-----------	---------	-------------------	-------------------------------

NO MAPPED SITES FOUND

Focus Map - 2 - 6171645.3s



- | | | |
|---------------------------------------------------------------------------------------------------------|------------------------------------------------------------------------------------------------------------------|-------------------------------------------------------------------------------------------------------------|
|  Sites |  Focus Map - Sites |  Dept. Defense Sites |
|  Target Property |  Power Line |  Indian Reservations BIA |
|  Search Buffer |  National Priority List Sites |  Areas of Concern |
|  Focus Map - No Sites | | |



SITE NAME: Cedar Solar 1
ADDRESS: SEC All American Canal & Bonds Corner
CITY/STATE: Calexico CA
ZIP: 92283

CLIENT: GS Lyon Consultants
CONTACT: Peter E. Labrucherie
INQUIRY #: 6171645.3s
DATE: 09/27/20

PC ORIGINAL PKG

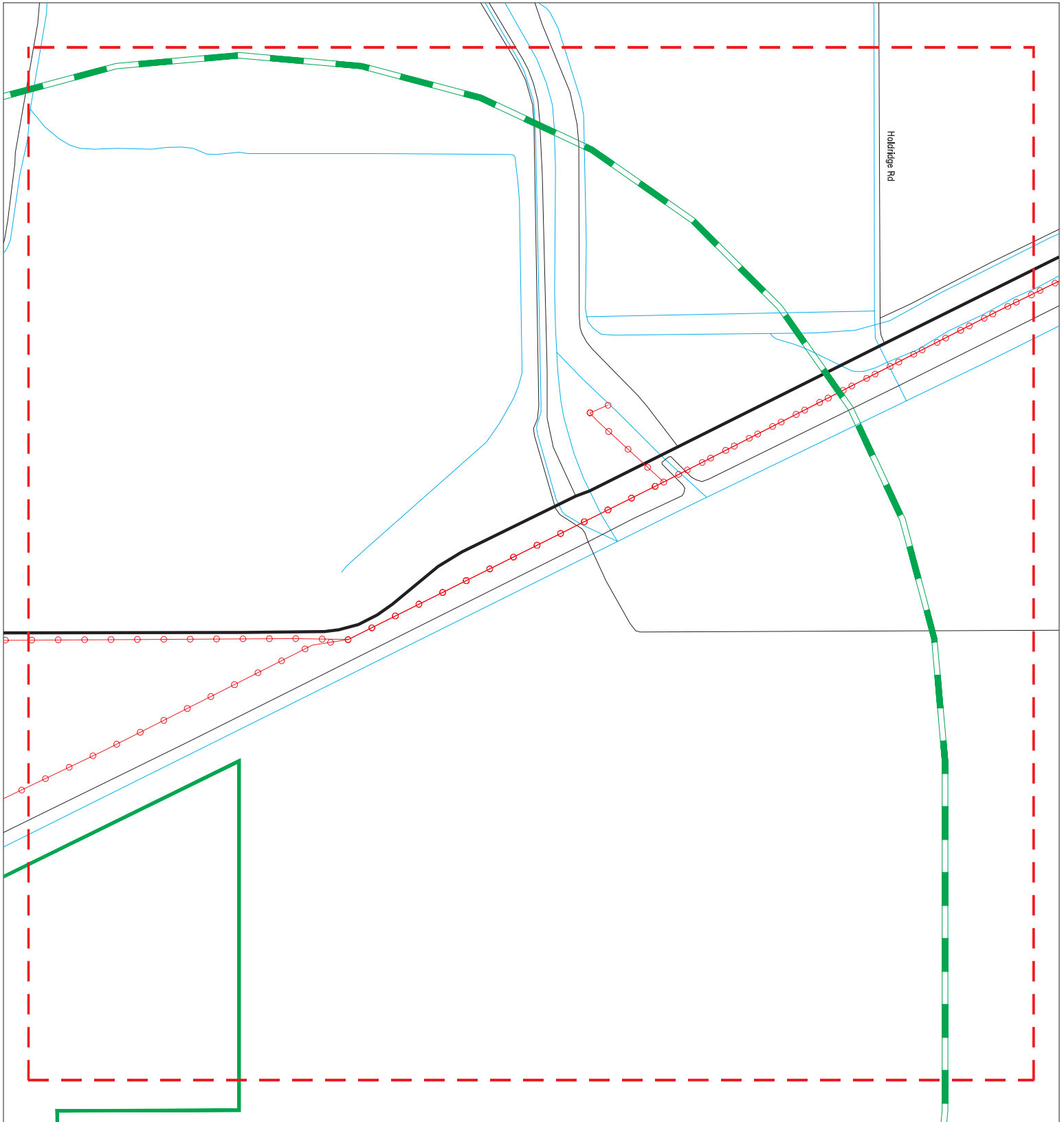
MAPPED SITES SUMMARY - FOCUS MAP 2











Target Property:
SEC ALL AMERICAN CANAL & BONDS CORNER
CALEXICO, CA 92283

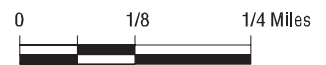
MAP ID / FOCUS MAP	SITE NAME	ADDRESS	DATABASE ACRONYMS	DIST (ft. & mi.) DIRECTION
-----------------------	-----------	---------	-------------------	-------------------------------

NO MAPPED SITES FOUND

Focus Map - 3 - 6171645.3s



- | | | |
|--------------------------------------------------------------------------------------------------------|------------------------------------------------------------------------------------------------------------------|-------------------------------------------------------------------------------------------------------------|
|  Sites |  Focus Map - Sites |  Dept. Defense Sites |
|  Target Property |  Power Line |  Indian Reservations BIA |
|  Search Buffer |  National Priority List Sites |  Areas of Concern |
|  Focus Map - No Sites | | |



SITE NAME: Cedar Solar 1
ADDRESS: SEC All American Canal & Bonds Corner
CITY/STATE: Calexico CA
ZIP: 92283

CLIENT: GS Lyon Consultants
CONTACT: Peter E. Labrucherie
INQUIRY #: 6171645.3s
DATE: 09/27/20

PC ORIGINAL PKG

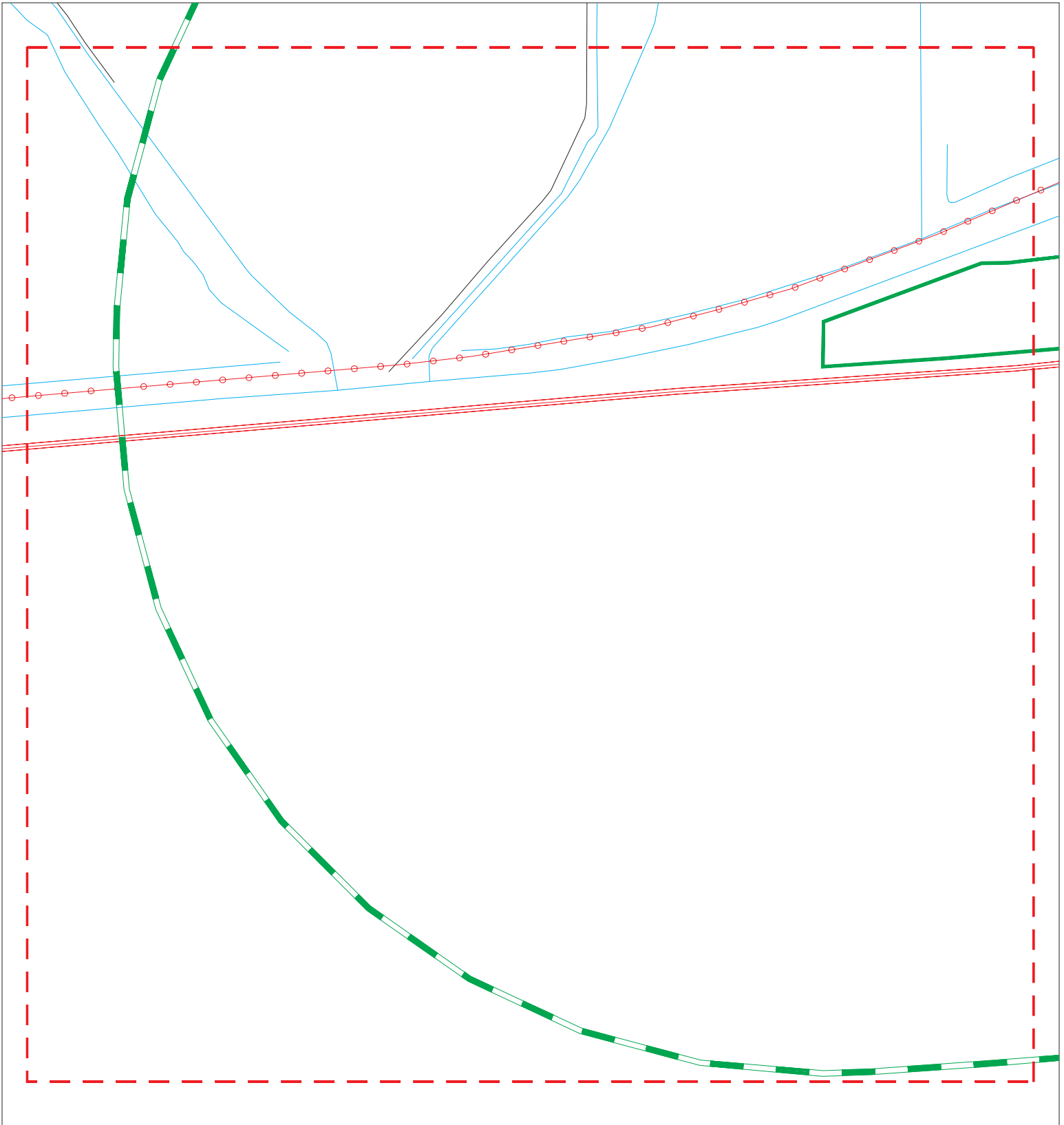
MAPPED SITES SUMMARY - FOCUS MAP 3











Target Property:
SEC ALL AMERICAN CANAL & BONDS CORNER
CALEXICO, CA 92283

MAP ID / FOCUS MAP	SITE NAME	ADDRESS	DATABASE ACRONYMS	DIST (ft. & mi.) DIRECTION
-----------------------	-----------	---------	-------------------	-------------------------------

NO MAPPED SITES FOUND

Focus Map - 4 - 6171645.3s



- | | | | | | |
|------------------------------------------------------------------------------------|----------------------|-------------------------------------------------------------------------------------|------------------------------|-------------------------------------------------------------------------------------|-------------------------|
|  | Sites |  | Focus Map - Sites |  | Dept. Defense Sites |
|  | Target Property |  | Power Line |  | Indian Reservations BIA |
|  | Search Buffer |  | National Priority List Sites |  | Areas of Concern |
|  | Focus Map - No Sites | | | | |



SITE NAME: Cedar Solar 1
ADDRESS: SEC All American Canal & Bonds Corner
CITY/STATE: Calexico CA
ZIP: 92283

CLIENT: GS Lyon Consultants
CONTACT: Peter E. Labrucherie
INQUIRY #: 6171645.3s
DATE: 09/27/20

PC ORIGINAL PKG

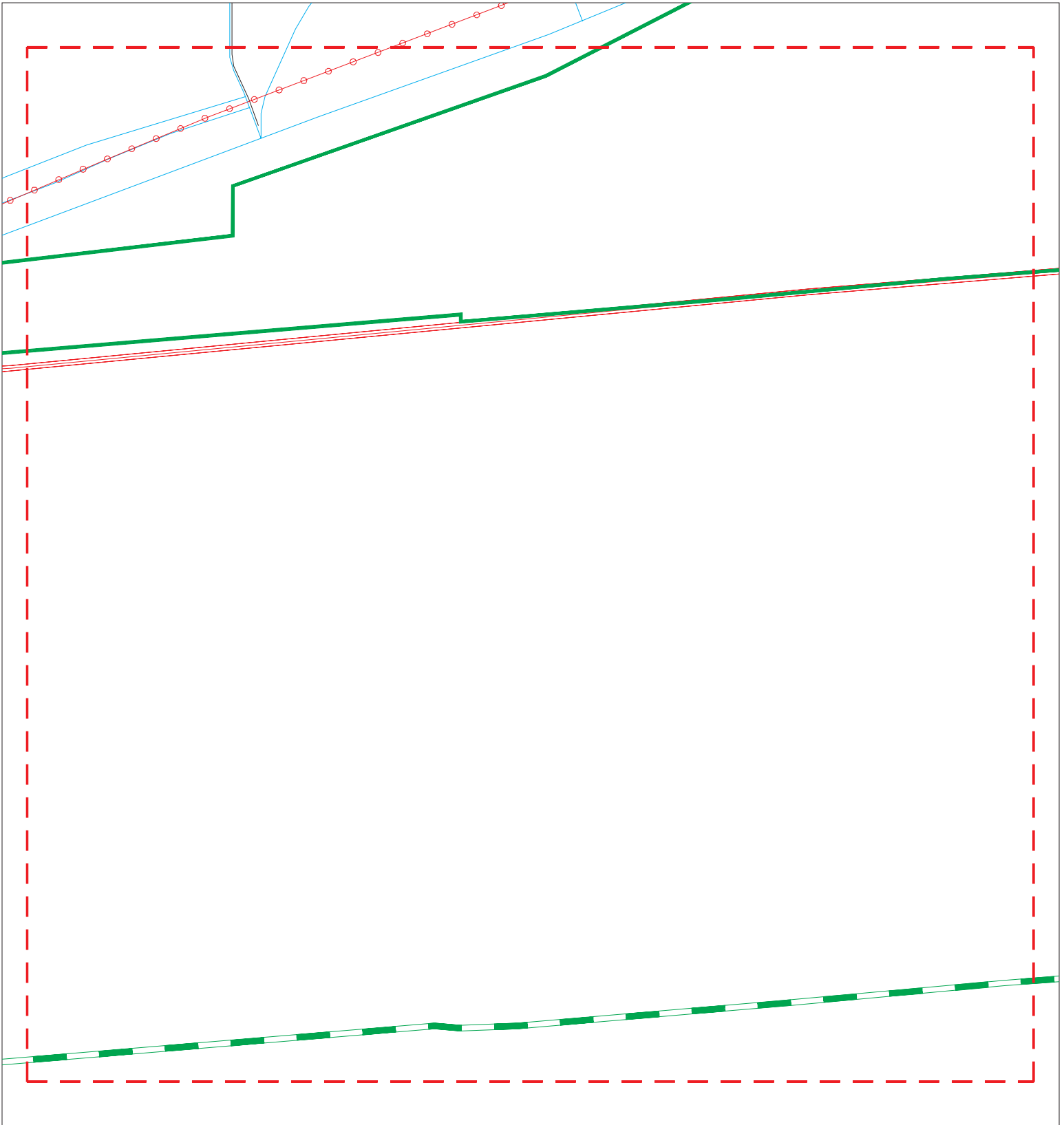
MAPPED SITES SUMMARY - FOCUS MAP 4











Target Property:
SEC ALL AMERICAN CANAL & BONDS CORNER
CALEXICO, CA 92283

MAP ID / FOCUS MAP	SITE NAME	ADDRESS	DATABASE ACRONYMS	DIST (ft. & mi.) DIRECTION
-----------------------	-----------	---------	-------------------	-------------------------------

NO MAPPED SITES FOUND

Focus Map - 5 - 6171645.3s



- | | | |
|---------------------------------------------------------------------------------------------------------|------------------------------------------------------------------------------------------------------------------|-------------------------------------------------------------------------------------------------------------|
|  Sites |  Focus Map - Sites |  Dept. Defense Sites |
|  Target Property |  Power Line |  Indian Reservations BIA |
|  Search Buffer |  National Priority List Sites |  Areas of Concern |
|  Focus Map - No Sites | | |



SITE NAME: Cedar Solar 1
 ADDRESS: SEC All American Canal & Bonds Corner
 CITY/STATE: Calexico CA
 ZIP: 92283

CLIENT: GS Lyon Consultants
 CONTACT: Peter E. Labrucherie
 INQUIRY #: 6171645.3s
 DATE: 09/27/20

PC ORIGINAL PKG

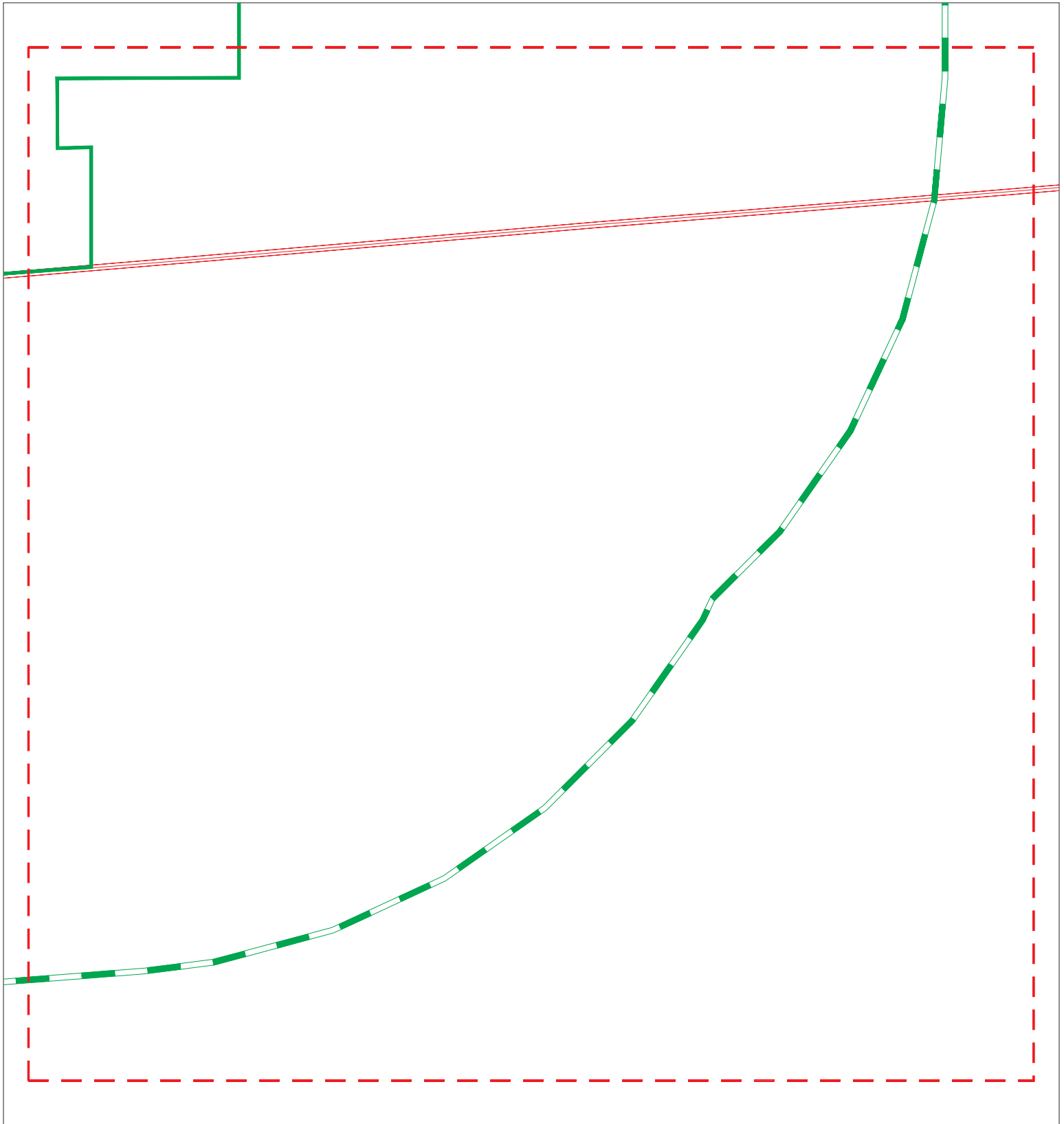
MAPPED SITES SUMMARY - FOCUS MAP 5











Target Property:
SEC ALL AMERICAN CANAL & BONDS CORNER
CALEXICO, CA 92283

MAP ID / FOCUS MAP	SITE NAME	ADDRESS	DATABASE ACRONYMS	DIST (ft. & mi.) DIRECTION
-----------------------	-----------	---------	-------------------	-------------------------------

NO MAPPED SITES FOUND

Focus Map - 6 - 6171645.3s



- | | | | | | |
|------------------------------------------------------------------------------------|----------------------|-------------------------------------------------------------------------------------|------------------------------|-------------------------------------------------------------------------------------|-------------------------|
|  | Sites |  | Focus Map - Sites |  | Dept. Defense Sites |
|  | Target Property |  | Power Line |  | Indian Reservations BIA |
|  | Search Buffer |  | National Priority List Sites |  | Areas of Concern |
|  | Focus Map - No Sites | | | | |



SITE NAME: Cedar Solar 1
 ADDRESS: SEC All American Canal & Bonds Corner
 CITY/STATE: Calexico CA
 ZIP: 92283

CLIENT: GS Lyon Consultants
 CONTACT: Peter E. Labrucherie
 INQUIRY #: 6171645.3s
 DATE: 09/27/20

PC ORIGINAL PKG

MAPPED SITES SUMMARY - FOCUS MAP 6

Target Property:
SEC ALL AMERICAN CANAL & BONDS CORNER
CALEXICO, CA 92283

MAP ID / FOCUS MAP	SITE NAME	ADDRESS	DATABASE ACRONYMS	DIST (ft. & mi.) DIRECTION
-----------------------	-----------	---------	-------------------	-------------------------------

NO MAPPED SITES FOUND

Map ID
Direction
Distance
Elevation

MAP FINDINGS

Site

Database(s)

EDR ID Number
EPA ID Number

NO SITES FOUND

Count: 1 records

ORPHAN SUMMARY

City	EDR ID	Site Name	Site Address	Zip	Database(s)
HOLTVILLE	S117696630	CALTRANS UTILITY RELOCATION PR	16 T16 S R15E SEC 11 12 13 14 23	92250	NPDES, CIWQS

GOVERNMENT RECORDS SEARCHED / DATA CURRENCY TRACKING

To maintain currency of the following federal and state databases, EDR contacts the appropriate governmental agency on a monthly or quarterly basis, as required.

Number of Days to Update: Provides confirmation that EDR is reporting records that have been updated within 90 days from the date the government agency made the information available to the public.

STANDARD ENVIRONMENTAL RECORDS

Federal NPL site list

NPL: National Priority List

National Priorities List (Superfund). The NPL is a subset of CERCLIS and identifies over 1,200 sites for priority cleanup under the Superfund Program. NPL sites may encompass relatively large areas. As such, EDR provides polygon coverage for over 1,000 NPL site boundaries produced by EPA's Environmental Photographic Interpretation Center (EPIC) and regional EPA offices.

Date of Government Version: 07/29/2020	Source: EPA
Date Data Arrived at EDR: 08/03/2020	Telephone: N/A
Date Made Active in Reports: 08/25/2020	Last EDR Contact: 08/03/2020
Number of Days to Update: 22	Next Scheduled EDR Contact: 10/12/2020
	Data Release Frequency: Quarterly

NPL Site Boundaries

Sources:

EPA's Environmental Photographic Interpretation Center (EPIC)
Telephone: 202-564-7333

EPA Region 1
Telephone 617-918-1143

EPA Region 6
Telephone: 214-655-6659

EPA Region 3
Telephone 215-814-5418

EPA Region 7
Telephone: 913-551-7247

EPA Region 4
Telephone 404-562-8033

EPA Region 8
Telephone: 303-312-6774

EPA Region 5
Telephone 312-886-6686

EPA Region 9
Telephone: 415-947-4246

EPA Region 10
Telephone 206-553-8665

Proposed NPL: Proposed National Priority List Sites

A site that has been proposed for listing on the National Priorities List through the issuance of a proposed rule in the Federal Register. EPA then accepts public comments on the site, responds to the comments, and places on the NPL those sites that continue to meet the requirements for listing.

Date of Government Version: 07/29/2020	Source: EPA
Date Data Arrived at EDR: 08/03/2020	Telephone: N/A
Date Made Active in Reports: 08/25/2020	Last EDR Contact: 08/03/2020
Number of Days to Update: 22	Next Scheduled EDR Contact: 10/12/2020
	Data Release Frequency: Quarterly

NPL LIENS: Federal Superfund Liens

Federal Superfund Liens. Under the authority granted the USEPA by CERCLA of 1980, the USEPA has the authority to file liens against real property in order to recover remedial action expenditures or when the property owner received notification of potential liability. USEPA compiles a listing of filed notices of Superfund Liens.

GOVERNMENT RECORDS SEARCHED / DATA CURRENCY TRACKING

Date of Government Version: 10/15/1991
Date Data Arrived at EDR: 02/02/1994
Date Made Active in Reports: 03/30/1994
Number of Days to Update: 56

Source: EPA
Telephone: 202-564-4267
Last EDR Contact: 08/15/2011
Next Scheduled EDR Contact: 11/28/2011
Data Release Frequency: No Update Planned

Federal Delisted NPL site list

Delisted NPL: National Priority List Deletions

The National Oil and Hazardous Substances Pollution Contingency Plan (NCP) establishes the criteria that the EPA uses to delete sites from the NPL. In accordance with 40 CFR 300.425.(e), sites may be deleted from the NPL where no further response is appropriate.

Date of Government Version: 07/29/2020
Date Data Arrived at EDR: 08/03/2020
Date Made Active in Reports: 08/25/2020
Number of Days to Update: 22

Source: EPA
Telephone: N/A
Last EDR Contact: 08/03/2020
Next Scheduled EDR Contact: 10/12/2020
Data Release Frequency: Quarterly

Federal CERCLIS list

FEDERAL FACILITY: Federal Facility Site Information listing

A listing of National Priority List (NPL) and Base Realignment and Closure (BRAC) sites found in the Comprehensive Environmental Response, Compensation and Liability Information System (CERCLIS) Database where EPA Federal Facilities Restoration and Reuse Office is involved in cleanup activities.

Date of Government Version: 04/03/2019
Date Data Arrived at EDR: 04/05/2019
Date Made Active in Reports: 05/14/2019
Number of Days to Update: 39

Source: Environmental Protection Agency
Telephone: 703-603-8704
Last EDR Contact: 07/02/2020
Next Scheduled EDR Contact: 10/12/2020
Data Release Frequency: Varies

SEMS: Superfund Enterprise Management System

SEMS (Superfund Enterprise Management System) tracks hazardous waste sites, potentially hazardous waste sites, and remedial activities performed in support of EPA's Superfund Program across the United States. The list was formerly known as CERCLIS, renamed to SEMS by the EPA in 2015. The list contains data on potentially hazardous waste sites that have been reported to the USEPA by states, municipalities, private companies and private persons, pursuant to Section 103 of the Comprehensive Environmental Response, Compensation, and Liability Act (CERCLA). This dataset also contains sites which are either proposed to or on the National Priorities List (NPL) and the sites which are in the screening and assessment phase for possible inclusion on the NPL.

Date of Government Version: 07/29/2020
Date Data Arrived at EDR: 08/03/2020
Date Made Active in Reports: 08/25/2020
Number of Days to Update: 22

Source: EPA
Telephone: 800-424-9346
Last EDR Contact: 08/03/2020
Next Scheduled EDR Contact: 10/26/2020
Data Release Frequency: Quarterly

Federal CERCLIS NFRAP site list

SEMS-ARCHIVE: Superfund Enterprise Management System Archive

GOVERNMENT RECORDS SEARCHED / DATA CURRENCY TRACKING

SEMS-ARCHIVE (Superfund Enterprise Management System Archive) tracks sites that have no further interest under the Federal Superfund Program based on available information. The list was formerly known as the CERCLIS-NFRAP, renamed to SEMS ARCHIVE by the EPA in 2015. EPA may perform a minimal level of assessment work at a site while it is archived if site conditions change and/or new information becomes available. Archived sites have been removed and archived from the inventory of SEMS sites. Archived status indicates that, to the best of EPA's knowledge, assessment at a site has been completed and that EPA has determined no further steps will be taken to list the site on the National Priorities List (NPL), unless information indicates this decision was not appropriate or other considerations require a recommendation for listing at a later time. The decision does not necessarily mean that there is no hazard associated with a given site; it only means that, based upon available information, the location is not judged to be potential NPL site.

Date of Government Version: 07/29/2020	Source: EPA
Date Data Arrived at EDR: 08/03/2020	Telephone: 800-424-9346
Date Made Active in Reports: 08/25/2020	Last EDR Contact: 08/03/2020
Number of Days to Update: 22	Next Scheduled EDR Contact: 10/26/2020
	Data Release Frequency: Quarterly

Federal RCRA CORRACTS facilities list

CORRACTS: Corrective Action Report

CORRACTS identifies hazardous waste handlers with RCRA corrective action activity.

Date of Government Version: 03/23/2020	Source: EPA
Date Data Arrived at EDR: 03/25/2020	Telephone: 800-424-9346
Date Made Active in Reports: 05/21/2020	Last EDR Contact: 06/22/2020
Number of Days to Update: 57	Next Scheduled EDR Contact: 10/05/2020
	Data Release Frequency: Quarterly

Federal RCRA non-CORRACTS TSD facilities list

RCRA-TSDF: RCRA - Treatment, Storage and Disposal

RCRAInfo is EPA's comprehensive information system, providing access to data supporting the Resource Conservation and Recovery Act (RCRA) of 1976 and the Hazardous and Solid Waste Amendments (HSWA) of 1984. The database includes selective information on sites which generate, transport, store, treat and/or dispose of hazardous waste as defined by the Resource Conservation and Recovery Act (RCRA). Transporters are individuals or entities that move hazardous waste from the generator offsite to a facility that can recycle, treat, store, or dispose of the waste. TSDFs treat, store, or dispose of the waste.

Date of Government Version: 03/23/2020	Source: Environmental Protection Agency
Date Data Arrived at EDR: 03/25/2020	Telephone: (415) 495-8895
Date Made Active in Reports: 05/21/2020	Last EDR Contact: 06/22/2020
Number of Days to Update: 57	Next Scheduled EDR Contact: 10/05/2020
	Data Release Frequency: Quarterly

Federal RCRA generators list

RCRA-LQG: RCRA - Large Quantity Generators

RCRAInfo is EPA's comprehensive information system, providing access to data supporting the Resource Conservation and Recovery Act (RCRA) of 1976 and the Hazardous and Solid Waste Amendments (HSWA) of 1984. The database includes selective information on sites which generate, transport, store, treat and/or dispose of hazardous waste as defined by the Resource Conservation and Recovery Act (RCRA). Large quantity generators (LQGs) generate over 1,000 kilograms (kg) of hazardous waste, or over 1 kg of acutely hazardous waste per month.

Date of Government Version: 03/23/2020	Source: Environmental Protection Agency
Date Data Arrived at EDR: 03/25/2020	Telephone: (415) 495-8895
Date Made Active in Reports: 05/21/2020	Last EDR Contact: 06/22/2020
Number of Days to Update: 57	Next Scheduled EDR Contact: 10/05/2020
	Data Release Frequency: Quarterly

GOVERNMENT RECORDS SEARCHED / DATA CURRENCY TRACKING

RCRA-SQG: RCRA - Small Quantity Generators

RCRAInfo is EPA's comprehensive information system, providing access to data supporting the Resource Conservation and Recovery Act (RCRA) of 1976 and the Hazardous and Solid Waste Amendments (HSWA) of 1984. The database includes selective information on sites which generate, transport, store, treat and/or dispose of hazardous waste as defined by the Resource Conservation and Recovery Act (RCRA). Small quantity generators (SQGs) generate between 100 kg and 1,000 kg of hazardous waste per month.

Date of Government Version: 03/23/2020	Source: Environmental Protection Agency
Date Data Arrived at EDR: 03/25/2020	Telephone: (415) 495-8895
Date Made Active in Reports: 05/21/2020	Last EDR Contact: 06/22/2020
Number of Days to Update: 57	Next Scheduled EDR Contact: 10/05/2020
	Data Release Frequency: Quarterly

RCRA-VSQG: RCRA - Very Small Quantity Generators (Formerly Conditionally Exempt Small Quantity Generators)

RCRAInfo is EPA's comprehensive information system, providing access to data supporting the Resource Conservation and Recovery Act (RCRA) of 1976 and the Hazardous and Solid Waste Amendments (HSWA) of 1984. The database includes selective information on sites which generate, transport, store, treat and/or dispose of hazardous waste as defined by the Resource Conservation and Recovery Act (RCRA). Very small quantity generators (VSQGs) generate less than 100 kg of hazardous waste, or less than 1 kg of acutely hazardous waste per month.

Date of Government Version: 03/23/2020	Source: Environmental Protection Agency
Date Data Arrived at EDR: 03/25/2020	Telephone: (415) 495-8895
Date Made Active in Reports: 05/21/2020	Last EDR Contact: 06/22/2020
Number of Days to Update: 57	Next Scheduled EDR Contact: 10/05/2020
	Data Release Frequency: Quarterly

Federal institutional controls / engineering controls registries

LUCIS: Land Use Control Information System

LUCIS contains records of land use control information pertaining to the former Navy Base Realignment and Closure properties.

Date of Government Version: 05/15/2020	Source: Department of the Navy
Date Data Arrived at EDR: 05/19/2020	Telephone: 843-820-7326
Date Made Active in Reports: 06/18/2020	Last EDR Contact: 08/04/2020
Number of Days to Update: 30	Next Scheduled EDR Contact: 11/23/2020
	Data Release Frequency: Varies

US ENG CONTROLS: Engineering Controls Sites List

A listing of sites with engineering controls in place. Engineering controls include various forms of caps, building foundations, liners, and treatment methods to create pathway elimination for regulated substances to enter environmental media or effect human health.

Date of Government Version: 02/13/2020	Source: Environmental Protection Agency
Date Data Arrived at EDR: 02/20/2020	Telephone: 703-603-0695
Date Made Active in Reports: 05/15/2020	Last EDR Contact: 08/24/2020
Number of Days to Update: 85	Next Scheduled EDR Contact: 09/07/2020
	Data Release Frequency: Varies

US INST CONTROLS: Institutional Controls Sites List

A listing of sites with institutional controls in place. Institutional controls include administrative measures, such as groundwater use restrictions, construction restrictions, property use restrictions, and post remediation care requirements intended to prevent exposure to contaminants remaining on site. Deed restrictions are generally required as part of the institutional controls.

Date of Government Version: 02/13/2020	Source: Environmental Protection Agency
Date Data Arrived at EDR: 02/20/2020	Telephone: 703-603-0695
Date Made Active in Reports: 05/15/2020	Last EDR Contact: 08/24/2020
Number of Days to Update: 85	Next Scheduled EDR Contact: 12/07/2020
	Data Release Frequency: Varies

GOVERNMENT RECORDS SEARCHED / DATA CURRENCY TRACKING

Federal ERNS list

ERNS: Emergency Response Notification System

Emergency Response Notification System. ERNS records and stores information on reported releases of oil and hazardous substances.

Date of Government Version: 03/22/2020
Date Data Arrived at EDR: 03/24/2020
Date Made Active in Reports: 06/18/2020
Number of Days to Update: 86

Source: National Response Center, United States Coast Guard
Telephone: 202-267-2180
Last EDR Contact: 06/22/2020
Next Scheduled EDR Contact: 10/05/2020
Data Release Frequency: Quarterly

State- and tribal - equivalent NPL

RESPONSE: State Response Sites

Identifies confirmed release sites where DTSC is involved in remediation, either in a lead or oversight capacity. These confirmed release sites are generally high-priority and high potential risk.

Date of Government Version: 04/27/2020
Date Data Arrived at EDR: 04/28/2020
Date Made Active in Reports: 07/13/2020
Number of Days to Update: 76

Source: Department of Toxic Substances Control
Telephone: 916-323-3400
Last EDR Contact: 07/27/2020
Next Scheduled EDR Contact: 11/09/2020
Data Release Frequency: Quarterly

State- and tribal - equivalent CERCLIS

ENVIROSTOR: EnviroStor Database

The Department of Toxic Substances Control's (DTSC's) Site Mitigation and Brownfields Reuse Program's (SMBRP's) EnviroStor database identifies sites that have known contamination or sites for which there may be reasons to investigate further. The database includes the following site types: Federal Superfund sites (National Priorities List (NPL)); State Response, including Military Facilities and State Superfund; Voluntary Cleanup; and School sites. EnviroStor provides similar information to the information that was available in CalSites, and provides additional site information, including, but not limited to, identification of formerly-contaminated properties that have been released for reuse, properties where environmental deed restrictions have been recorded to prevent inappropriate land uses, and risk characterization information that is used to assess potential impacts to public health and the environment at contaminated sites.

Date of Government Version: 04/27/2020
Date Data Arrived at EDR: 04/28/2020
Date Made Active in Reports: 07/13/2020
Number of Days to Update: 76

Source: Department of Toxic Substances Control
Telephone: 916-323-3400
Last EDR Contact: 07/27/2020
Next Scheduled EDR Contact: 11/09/2020
Data Release Frequency: Quarterly

State and tribal landfill and/or solid waste disposal site lists

SWF/LF (SWIS): Solid Waste Information System

Active, Closed and Inactive Landfills. SWF/LF records typically contain an inventory of solid waste disposal facilities or landfills. These may be active or inactive facilities or open dumps that failed to meet RCRA Section 4004 criteria for solid waste landfills or disposal sites.

Date of Government Version: 05/11/2020
Date Data Arrived at EDR: 05/12/2020
Date Made Active in Reports: 07/27/2020
Number of Days to Update: 76

Source: Department of Resources Recycling and Recovery
Telephone: 916-341-6320
Last EDR Contact: 08/10/2020
Next Scheduled EDR Contact: 11/23/2020
Data Release Frequency: Quarterly

State and tribal leaking storage tank lists

GOVERNMENT RECORDS SEARCHED / DATA CURRENCY TRACKING

LUST REG 2: Fuel Leak List

Leaking Underground Storage Tank locations. Alameda, Contra Costa, Marin, Napa, San Francisco, San Mateo, Santa Clara, Solano, Sonoma counties.

Date of Government Version: 09/30/2004
Date Data Arrived at EDR: 10/20/2004
Date Made Active in Reports: 11/19/2004
Number of Days to Update: 30

Source: California Regional Water Quality Control Board San Francisco Bay Region (2)
Telephone: 510-622-2433
Last EDR Contact: 09/19/2011
Next Scheduled EDR Contact: 01/02/2012
Data Release Frequency: No Update Planned

LUST REG 3: Leaking Underground Storage Tank Database

Leaking Underground Storage Tank locations. Monterey, San Benito, San Luis Obispo, Santa Barbara, Santa Cruz counties.

Date of Government Version: 05/19/2003
Date Data Arrived at EDR: 05/19/2003
Date Made Active in Reports: 06/02/2003
Number of Days to Update: 14

Source: California Regional Water Quality Control Board Central Coast Region (3)
Telephone: 805-542-4786
Last EDR Contact: 07/18/2011
Next Scheduled EDR Contact: 10/31/2011
Data Release Frequency: No Update Planned

LUST REG 4: Underground Storage Tank Leak List

Los Angeles, Ventura counties. For more current information, please refer to the State Water Resources Control Board's LUST database.

Date of Government Version: 09/07/2004
Date Data Arrived at EDR: 09/07/2004
Date Made Active in Reports: 10/12/2004
Number of Days to Update: 35

Source: California Regional Water Quality Control Board Los Angeles Region (4)
Telephone: 213-576-6710
Last EDR Contact: 09/06/2011
Next Scheduled EDR Contact: 12/19/2011
Data Release Frequency: No Update Planned

LUST REG 9: Leaking Underground Storage Tank Report

Orange, Riverside, San Diego counties. For more current information, please refer to the State Water Resources Control Board's LUST database.

Date of Government Version: 03/01/2001
Date Data Arrived at EDR: 04/23/2001
Date Made Active in Reports: 05/21/2001
Number of Days to Update: 28

Source: California Regional Water Quality Control Board San Diego Region (9)
Telephone: 858-637-5595
Last EDR Contact: 09/26/2011
Next Scheduled EDR Contact: 01/09/2012
Data Release Frequency: No Update Planned

LUST REG 8: Leaking Underground Storage Tanks

California Regional Water Quality Control Board Santa Ana Region (8). For more current information, please refer to the State Water Resources Control Board's LUST database.

Date of Government Version: 02/14/2005
Date Data Arrived at EDR: 02/15/2005
Date Made Active in Reports: 03/28/2005
Number of Days to Update: 41

Source: California Regional Water Quality Control Board Santa Ana Region (8)
Telephone: 909-782-4496
Last EDR Contact: 08/15/2011
Next Scheduled EDR Contact: 11/28/2011
Data Release Frequency: No Update Planned

LUST REG 5: Leaking Underground Storage Tank Database

Leaking Underground Storage Tank locations. Alameda, Alpine, Amador, Butte, Colusa, Contra Costa, Calveras, El Dorado, Fresno, Glenn, Kern, Kings, Lake, Lassen, Madera, Mariposa, Merced, Modoc, Napa, Nevada, Placer, Plumas, Sacramento, San Joaquin, Shasta, Solano, Stanislaus, Sutter, Tehama, Tulare, Tuolumne, Yolo, Yuba counties.

Date of Government Version: 07/01/2008
Date Data Arrived at EDR: 07/22/2008
Date Made Active in Reports: 07/31/2008
Number of Days to Update: 9

Source: California Regional Water Quality Control Board Central Valley Region (5)
Telephone: 916-464-4834
Last EDR Contact: 07/01/2011
Next Scheduled EDR Contact: 10/17/2011
Data Release Frequency: No Update Planned

GOVERNMENT RECORDS SEARCHED / DATA CURRENCY TRACKING

LUST REG 6L: Leaking Underground Storage Tank Case Listing

For more current information, please refer to the State Water Resources Control Board's LUST database.

Date of Government Version: 09/09/2003	Source: California Regional Water Quality Control Board Lahontan Region (6)
Date Data Arrived at EDR: 09/10/2003	Telephone: 530-542-5572
Date Made Active in Reports: 10/07/2003	Last EDR Contact: 09/12/2011
Number of Days to Update: 27	Next Scheduled EDR Contact: 12/26/2011
	Data Release Frequency: No Update Planned

LUST REG 6V: Leaking Underground Storage Tank Case Listing

Leaking Underground Storage Tank locations. Inyo, Kern, Los Angeles, Mono, San Bernardino counties.

Date of Government Version: 06/07/2005	Source: California Regional Water Quality Control Board Victorville Branch Office (6)
Date Data Arrived at EDR: 06/07/2005	Telephone: 760-241-7365
Date Made Active in Reports: 06/29/2005	Last EDR Contact: 09/12/2011
Number of Days to Update: 22	Next Scheduled EDR Contact: 12/26/2011
	Data Release Frequency: No Update Planned

LUST REG 1: Active Toxic Site Investigation

Del Norte, Humboldt, Lake, Mendocino, Modoc, Siskiyou, Sonoma, Trinity counties. For more current information, please refer to the State Water Resources Control Board's LUST database.

Date of Government Version: 02/01/2001	Source: California Regional Water Quality Control Board North Coast (1)
Date Data Arrived at EDR: 02/28/2001	Telephone: 707-570-3769
Date Made Active in Reports: 03/29/2001	Last EDR Contact: 08/01/2011
Number of Days to Update: 29	Next Scheduled EDR Contact: 11/14/2011
	Data Release Frequency: No Update Planned

LUST REG 7: Leaking Underground Storage Tank Case Listing

Leaking Underground Storage Tank locations. Imperial, Riverside, San Diego, Santa Barbara counties.

Date of Government Version: 02/26/2004	Source: California Regional Water Quality Control Board Colorado River Basin Region (7)
Date Data Arrived at EDR: 02/26/2004	Telephone: 760-776-8943
Date Made Active in Reports: 03/24/2004	Last EDR Contact: 08/01/2011
Number of Days to Update: 27	Next Scheduled EDR Contact: 11/14/2011
	Data Release Frequency: No Update Planned

LUST: Leaking Underground Fuel Tank Report (GEOTRACKER)

Leaking Underground Storage Tank (LUST) Sites included in GeoTracker. GeoTracker is the Water Boards data management system for sites that impact, or have the potential to impact, water quality in California, with emphasis on groundwater.

Date of Government Version: 06/08/2020	Source: State Water Resources Control Board
Date Data Arrived at EDR: 06/09/2020	Telephone: see region list
Date Made Active in Reports: 08/19/2020	Last EDR Contact: 06/09/2020
Number of Days to Update: 71	Next Scheduled EDR Contact: 09/21/2020
	Data Release Frequency: Quarterly

INDIAN LUST R10: Leaking Underground Storage Tanks on Indian Land

LUSTs on Indian land in Alaska, Idaho, Oregon and Washington.

Date of Government Version: 04/14/2020	Source: EPA Region 10
Date Data Arrived at EDR: 05/20/2020	Telephone: 206-553-2857
Date Made Active in Reports: 08/12/2020	Last EDR Contact: 07/24/2020
Number of Days to Update: 84	Next Scheduled EDR Contact: 11/02/2020
	Data Release Frequency: Varies

INDIAN LUST R4: Leaking Underground Storage Tanks on Indian Land

LUSTs on Indian land in Florida, Mississippi and North Carolina.

Date of Government Version: 04/14/2020	Source: EPA Region 4
Date Data Arrived at EDR: 05/26/2020	Telephone: 404-562-8677
Date Made Active in Reports: 08/12/2020	Last EDR Contact: 07/24/2020
Number of Days to Update: 78	Next Scheduled EDR Contact: 11/02/2020
	Data Release Frequency: Varies

GOVERNMENT RECORDS SEARCHED / DATA CURRENCY TRACKING

INDIAN LUST R5: Leaking Underground Storage Tanks on Indian Land

Leaking underground storage tanks located on Indian Land in Michigan, Minnesota and Wisconsin.

Date of Government Version: 04/14/2020	Source: EPA, Region 5
Date Data Arrived at EDR: 05/20/2020	Telephone: 312-886-7439
Date Made Active in Reports: 08/12/2020	Last EDR Contact: 07/24/2020
Number of Days to Update: 84	Next Scheduled EDR Contact: 11/02/2020
	Data Release Frequency: Varies

INDIAN LUST R1: Leaking Underground Storage Tanks on Indian Land

A listing of leaking underground storage tank locations on Indian Land.

Date of Government Version: 04/29/2020	Source: EPA Region 1
Date Data Arrived at EDR: 05/20/2020	Telephone: 617-918-1313
Date Made Active in Reports: 08/12/2020	Last EDR Contact: 07/24/2020
Number of Days to Update: 84	Next Scheduled EDR Contact: 11/02/2020
	Data Release Frequency: Varies

INDIAN LUST R6: Leaking Underground Storage Tanks on Indian Land

LUSTs on Indian land in New Mexico and Oklahoma.

Date of Government Version: 04/08/2020	Source: EPA Region 6
Date Data Arrived at EDR: 05/20/2020	Telephone: 214-665-6597
Date Made Active in Reports: 08/12/2020	Last EDR Contact: 07/24/2020
Number of Days to Update: 84	Next Scheduled EDR Contact: 11/02/2020
	Data Release Frequency: Varies

INDIAN LUST R7: Leaking Underground Storage Tanks on Indian Land

LUSTs on Indian land in Iowa, Kansas, and Nebraska

Date of Government Version: 04/15/2020	Source: EPA Region 7
Date Data Arrived at EDR: 05/20/2020	Telephone: 913-551-7003
Date Made Active in Reports: 08/12/2020	Last EDR Contact: 07/24/2020
Number of Days to Update: 84	Next Scheduled EDR Contact: 11/02/2020
	Data Release Frequency: Varies

INDIAN LUST R8: Leaking Underground Storage Tanks on Indian Land

LUSTs on Indian land in Colorado, Montana, North Dakota, South Dakota, Utah and Wyoming.

Date of Government Version: 04/14/2020	Source: EPA Region 8
Date Data Arrived at EDR: 05/20/2020	Telephone: 303-312-6271
Date Made Active in Reports: 08/12/2020	Last EDR Contact: 07/24/2020
Number of Days to Update: 84	Next Scheduled EDR Contact: 11/02/2020
	Data Release Frequency: Varies

INDIAN LUST R9: Leaking Underground Storage Tanks on Indian Land

LUSTs on Indian land in Arizona, California, New Mexico and Nevada

Date of Government Version: 04/08/2020	Source: Environmental Protection Agency
Date Data Arrived at EDR: 05/20/2020	Telephone: 415-972-3372
Date Made Active in Reports: 08/12/2020	Last EDR Contact: 07/24/2020
Number of Days to Update: 84	Next Scheduled EDR Contact: 11/02/2020
	Data Release Frequency: Varies

CPS-SLIC: Statewide SLIC Cases (GEOTRACKER)

Cleanup Program Sites (CPS; also known as Site Cleanups [SC] and formerly known as Spills, Leaks, Investigations, and Cleanups [SLIC] sites) included in GeoTracker. GeoTracker is the Water Boards data management system for sites that impact, or have the potential to impact, water quality in California, with emphasis on groundwater.

Date of Government Version: 06/08/2020	Source: State Water Resources Control Board
Date Data Arrived at EDR: 06/09/2020	Telephone: 866-480-1028
Date Made Active in Reports: 08/19/2020	Last EDR Contact: 06/09/2020
Number of Days to Update: 71	Next Scheduled EDR Contact: 09/21/2020
	Data Release Frequency: Varies

GOVERNMENT RECORDS SEARCHED / DATA CURRENCY TRACKING

SLIC REG 1: Active Toxic Site Investigations

The SLIC (Spills, Leaks, Investigations and Cleanup) program is designed to protect and restore water quality from spills, leaks, and similar discharges.

Date of Government Version: 04/03/2003
Date Data Arrived at EDR: 04/07/2003
Date Made Active in Reports: 04/25/2003
Number of Days to Update: 18

Source: California Regional Water Quality Control Board, North Coast Region (1)
Telephone: 707-576-2220
Last EDR Contact: 08/01/2011
Next Scheduled EDR Contact: 11/14/2011
Data Release Frequency: No Update Planned

SLIC REG 2: Spills, Leaks, Investigation & Cleanup Cost Recovery Listing

The SLIC (Spills, Leaks, Investigations and Cleanup) program is designed to protect and restore water quality from spills, leaks, and similar discharges.

Date of Government Version: 09/30/2004
Date Data Arrived at EDR: 10/20/2004
Date Made Active in Reports: 11/19/2004
Number of Days to Update: 30

Source: Regional Water Quality Control Board San Francisco Bay Region (2)
Telephone: 510-286-0457
Last EDR Contact: 09/19/2011
Next Scheduled EDR Contact: 01/02/2012
Data Release Frequency: No Update Planned

SLIC REG 3: Spills, Leaks, Investigation & Cleanup Cost Recovery Listing

The SLIC (Spills, Leaks, Investigations and Cleanup) program is designed to protect and restore water quality from spills, leaks, and similar discharges.

Date of Government Version: 05/18/2006
Date Data Arrived at EDR: 05/18/2006
Date Made Active in Reports: 06/15/2006
Number of Days to Update: 28

Source: California Regional Water Quality Control Board Central Coast Region (3)
Telephone: 805-549-3147
Last EDR Contact: 07/18/2011
Next Scheduled EDR Contact: 10/31/2011
Data Release Frequency: No Update Planned

SLIC REG 4: Spills, Leaks, Investigation & Cleanup Cost Recovery Listing

The SLIC (Spills, Leaks, Investigations and Cleanup) program is designed to protect and restore water quality from spills, leaks, and similar discharges.

Date of Government Version: 11/17/2004
Date Data Arrived at EDR: 11/18/2004
Date Made Active in Reports: 01/04/2005
Number of Days to Update: 47

Source: Region Water Quality Control Board Los Angeles Region (4)
Telephone: 213-576-6600
Last EDR Contact: 07/01/2011
Next Scheduled EDR Contact: 10/17/2011
Data Release Frequency: No Update Planned

SLIC REG 5: Spills, Leaks, Investigation & Cleanup Cost Recovery Listing

The SLIC (Spills, Leaks, Investigations and Cleanup) program is designed to protect and restore water quality from spills, leaks, and similar discharges.

Date of Government Version: 04/01/2005
Date Data Arrived at EDR: 04/05/2005
Date Made Active in Reports: 04/21/2005
Number of Days to Update: 16

Source: Regional Water Quality Control Board Central Valley Region (5)
Telephone: 916-464-3291
Last EDR Contact: 09/12/2011
Next Scheduled EDR Contact: 12/26/2011
Data Release Frequency: No Update Planned

SLIC REG 6V: Spills, Leaks, Investigation & Cleanup Cost Recovery Listing

The SLIC (Spills, Leaks, Investigations and Cleanup) program is designed to protect and restore water quality from spills, leaks, and similar discharges.

Date of Government Version: 05/24/2005
Date Data Arrived at EDR: 05/25/2005
Date Made Active in Reports: 06/16/2005
Number of Days to Update: 22

Source: Regional Water Quality Control Board, Victorville Branch
Telephone: 619-241-6583
Last EDR Contact: 08/15/2011
Next Scheduled EDR Contact: 11/28/2011
Data Release Frequency: No Update Planned

GOVERNMENT RECORDS SEARCHED / DATA CURRENCY TRACKING

SLIC REG 6L: SLIC Sites

The SLIC (Spills, Leaks, Investigations and Cleanup) program is designed to protect and restore water quality from spills, leaks, and similar discharges.

Date of Government Version: 09/07/2004
Date Data Arrived at EDR: 09/07/2004
Date Made Active in Reports: 10/12/2004
Number of Days to Update: 35

Source: California Regional Water Quality Control Board, Lahontan Region
Telephone: 530-542-5574
Last EDR Contact: 08/15/2011
Next Scheduled EDR Contact: 11/28/2011
Data Release Frequency: No Update Planned

SLIC REG 7: SLIC List

The SLIC (Spills, Leaks, Investigations and Cleanup) program is designed to protect and restore water quality from spills, leaks, and similar discharges.

Date of Government Version: 11/24/2004
Date Data Arrived at EDR: 11/29/2004
Date Made Active in Reports: 01/04/2005
Number of Days to Update: 36

Source: California Regional Quality Control Board, Colorado River Basin Region
Telephone: 760-346-7491
Last EDR Contact: 08/01/2011
Next Scheduled EDR Contact: 11/14/2011
Data Release Frequency: No Update Planned

SLIC REG 8: Spills, Leaks, Investigation & Cleanup Cost Recovery Listing

The SLIC (Spills, Leaks, Investigations and Cleanup) program is designed to protect and restore water quality from spills, leaks, and similar discharges.

Date of Government Version: 04/03/2008
Date Data Arrived at EDR: 04/03/2008
Date Made Active in Reports: 04/14/2008
Number of Days to Update: 11

Source: California Region Water Quality Control Board Santa Ana Region (8)
Telephone: 951-782-3298
Last EDR Contact: 09/12/2011
Next Scheduled EDR Contact: 12/26/2011
Data Release Frequency: No Update Planned

SLIC REG 9: Spills, Leaks, Investigation & Cleanup Cost Recovery Listing

The SLIC (Spills, Leaks, Investigations and Cleanup) program is designed to protect and restore water quality from spills, leaks, and similar discharges.

Date of Government Version: 09/10/2007
Date Data Arrived at EDR: 09/11/2007
Date Made Active in Reports: 09/28/2007
Number of Days to Update: 17

Source: California Regional Water Quality Control Board San Diego Region (9)
Telephone: 858-467-2980
Last EDR Contact: 08/08/2011
Next Scheduled EDR Contact: 11/21/2011
Data Release Frequency: No Update Planned

State and tribal registered storage tank lists

FEMA UST: Underground Storage Tank Listing

A listing of all FEMA owned underground storage tanks.

Date of Government Version: 02/01/2020
Date Data Arrived at EDR: 03/19/2020
Date Made Active in Reports: 06/09/2020
Number of Days to Update: 82

Source: FEMA
Telephone: 202-646-5797
Last EDR Contact: 07/06/2020
Next Scheduled EDR Contact: 10/19/2020
Data Release Frequency: Varies

MILITARY UST SITES: Military UST Sites (GEOTRACKER)

Military ust sites

Date of Government Version: 06/08/2020
Date Data Arrived at EDR: 06/09/2020
Date Made Active in Reports: 08/19/2020
Number of Days to Update: 71

Source: State Water Resources Control Board
Telephone: 866-480-1028
Last EDR Contact: 06/09/2020
Next Scheduled EDR Contact: 09/21/2020
Data Release Frequency: Varies

GOVERNMENT RECORDS SEARCHED / DATA CURRENCY TRACKING

UST: Active UST Facilities

Active UST facilities gathered from the local regulatory agencies

Date of Government Version: 06/08/2020	Source: SWRCB
Date Data Arrived at EDR: 06/09/2020	Telephone: 916-341-5851
Date Made Active in Reports: 08/20/2020	Last EDR Contact: 06/09/2020
Number of Days to Update: 72	Next Scheduled EDR Contact: 09/21/2020
	Data Release Frequency: Semi-Annually

UST CLOSURE: Proposed Closure of Underground Storage Tank (UST) Cases

UST cases that are being considered for closure by either the State Water Resources Control Board or the Executive Director have been posted for a 60-day public comment period. UST Case Closures being proposed for consideration by the State Water Resources Control Board. These are primarily UST cases that meet closure criteria under the decisional framework in State Water Board Resolution No. 92-49 and other Board orders. UST Case Closures proposed for consideration by the Executive Director pursuant to State Water Board Resolution No. 2012-0061. These are cases that meet the criteria of the Low-Threat UST Case Closure Policy. UST Case Closure Review Denials and Approved Orders.

Date of Government Version: 05/26/2020	Source: State Water Resources Control Board
Date Data Arrived at EDR: 06/09/2020	Telephone: 916-327-7844
Date Made Active in Reports: 08/20/2020	Last EDR Contact: 06/09/2020
Number of Days to Update: 72	Next Scheduled EDR Contact: 09/21/2020
	Data Release Frequency: Varies

AST: Aboveground Petroleum Storage Tank Facilities

A listing of aboveground storage tank petroleum storage tank locations.

Date of Government Version: 07/06/2016	Source: California Environmental Protection Agency
Date Data Arrived at EDR: 07/12/2016	Telephone: 916-327-5092
Date Made Active in Reports: 09/19/2016	Last EDR Contact: 06/10/2020
Number of Days to Update: 69	Next Scheduled EDR Contact: 09/28/2020
	Data Release Frequency: Varies

INDIAN UST R4: Underground Storage Tanks on Indian Land

The Indian Underground Storage Tank (UST) database provides information about underground storage tanks on Indian land in EPA Region 4 (Alabama, Florida, Georgia, Kentucky, Mississippi, North Carolina, South Carolina, Tennessee and Tribal Nations)

Date of Government Version: 04/14/2020	Source: EPA Region 4
Date Data Arrived at EDR: 05/26/2020	Telephone: 404-562-9424
Date Made Active in Reports: 08/12/2020	Last EDR Contact: 07/24/2020
Number of Days to Update: 78	Next Scheduled EDR Contact: 11/02/2020
	Data Release Frequency: Varies

INDIAN UST R5: Underground Storage Tanks on Indian Land

The Indian Underground Storage Tank (UST) database provides information about underground storage tanks on Indian land in EPA Region 5 (Michigan, Minnesota and Wisconsin and Tribal Nations).

Date of Government Version: 04/14/2020	Source: EPA Region 5
Date Data Arrived at EDR: 05/20/2020	Telephone: 312-886-6136
Date Made Active in Reports: 08/12/2020	Last EDR Contact: 07/24/2020
Number of Days to Update: 84	Next Scheduled EDR Contact: 11/02/2020
	Data Release Frequency: Varies

INDIAN UST R10: Underground Storage Tanks on Indian Land

The Indian Underground Storage Tank (UST) database provides information about underground storage tanks on Indian land in EPA Region 10 (Alaska, Idaho, Oregon, Washington, and Tribal Nations).

Date of Government Version: 04/14/2020	Source: EPA Region 10
Date Data Arrived at EDR: 05/20/2020	Telephone: 206-553-2857
Date Made Active in Reports: 08/12/2020	Last EDR Contact: 07/24/2020
Number of Days to Update: 84	Next Scheduled EDR Contact: 11/02/2020
	Data Release Frequency: Varies

GOVERNMENT RECORDS SEARCHED / DATA CURRENCY TRACKING

INDIAN UST R7: Underground Storage Tanks on Indian Land

The Indian Underground Storage Tank (UST) database provides information about underground storage tanks on Indian land in EPA Region 7 (Iowa, Kansas, Missouri, Nebraska, and 9 Tribal Nations).

Date of Government Version: 04/03/2020	Source: EPA Region 7
Date Data Arrived at EDR: 05/20/2020	Telephone: 913-551-7003
Date Made Active in Reports: 08/12/2020	Last EDR Contact: 07/24/2020
Number of Days to Update: 84	Next Scheduled EDR Contact: 11/02/2020
	Data Release Frequency: Varies

INDIAN UST R6: Underground Storage Tanks on Indian Land

The Indian Underground Storage Tank (UST) database provides information about underground storage tanks on Indian land in EPA Region 6 (Louisiana, Arkansas, Oklahoma, New Mexico, Texas and 65 Tribes).

Date of Government Version: 04/08/2020	Source: EPA Region 6
Date Data Arrived at EDR: 05/20/2020	Telephone: 214-665-7591
Date Made Active in Reports: 08/12/2020	Last EDR Contact: 07/24/2020
Number of Days to Update: 84	Next Scheduled EDR Contact: 11/02/2020
	Data Release Frequency: Varies

INDIAN UST R9: Underground Storage Tanks on Indian Land

The Indian Underground Storage Tank (UST) database provides information about underground storage tanks on Indian land in EPA Region 9 (Arizona, California, Hawaii, Nevada, the Pacific Islands, and Tribal Nations).

Date of Government Version: 04/08/2020	Source: EPA Region 9
Date Data Arrived at EDR: 05/20/2020	Telephone: 415-972-3368
Date Made Active in Reports: 08/12/2020	Last EDR Contact: 07/23/2020
Number of Days to Update: 84	Next Scheduled EDR Contact: 11/01/2020
	Data Release Frequency: Varies

INDIAN UST R1: Underground Storage Tanks on Indian Land

The Indian Underground Storage Tank (UST) database provides information about underground storage tanks on Indian land in EPA Region 1 (Connecticut, Maine, Massachusetts, New Hampshire, Rhode Island, Vermont and ten Tribal Nations).

Date of Government Version: 04/29/2020	Source: EPA, Region 1
Date Data Arrived at EDR: 05/20/2020	Telephone: 617-918-1313
Date Made Active in Reports: 08/12/2020	Last EDR Contact: 07/24/2020
Number of Days to Update: 84	Next Scheduled EDR Contact: 11/02/2020
	Data Release Frequency: Varies

INDIAN UST R8: Underground Storage Tanks on Indian Land

The Indian Underground Storage Tank (UST) database provides information about underground storage tanks on Indian land in EPA Region 8 (Colorado, Montana, North Dakota, South Dakota, Utah, Wyoming and 27 Tribal Nations).

Date of Government Version: 04/14/2020	Source: EPA Region 8
Date Data Arrived at EDR: 05/20/2020	Telephone: 303-312-6137
Date Made Active in Reports: 08/13/2020	Last EDR Contact: 07/24/2020
Number of Days to Update: 85	Next Scheduled EDR Contact: 11/02/2020
	Data Release Frequency: Varies

State and tribal voluntary cleanup sites

VCP: Voluntary Cleanup Program Properties

Contains low threat level properties with either confirmed or unconfirmed releases and the project proponents have request that DTSC oversee investigation and/or cleanup activities and have agreed to provide coverage for DTSC's costs.

Date of Government Version: 04/27/2020	Source: Department of Toxic Substances Control
Date Data Arrived at EDR: 04/28/2020	Telephone: 916-323-3400
Date Made Active in Reports: 07/13/2020	Last EDR Contact: 07/27/2020
Number of Days to Update: 76	Next Scheduled EDR Contact: 11/09/2020
	Data Release Frequency: Quarterly

GOVERNMENT RECORDS SEARCHED / DATA CURRENCY TRACKING

INDIAN VCP R7: Voluntary Cleanup Priority Listing

A listing of voluntary cleanup priority sites located on Indian Land located in Region 7.

Date of Government Version: 03/20/2008	Source: EPA, Region 7
Date Data Arrived at EDR: 04/22/2008	Telephone: 913-551-7365
Date Made Active in Reports: 05/19/2008	Last EDR Contact: 04/20/2009
Number of Days to Update: 27	Next Scheduled EDR Contact: 07/20/2009
	Data Release Frequency: Varies

INDIAN VCP R1: Voluntary Cleanup Priority Listing

A listing of voluntary cleanup priority sites located on Indian Land located in Region 1.

Date of Government Version: 07/27/2015	Source: EPA, Region 1
Date Data Arrived at EDR: 09/29/2015	Telephone: 617-918-1102
Date Made Active in Reports: 02/18/2016	Last EDR Contact: 06/17/2020
Number of Days to Update: 142	Next Scheduled EDR Contact: 10/05/2020
	Data Release Frequency: Varies

State and tribal Brownfields sites

BROWNFIELDS: Considered Brownfields Sites Listing

A listing of sites the SWRCB considers to be Brownfields since these are sites have come to them through the MOA Process.

Date of Government Version: 03/23/2020	Source: State Water Resources Control Board
Date Data Arrived at EDR: 03/24/2020	Telephone: 916-323-7905
Date Made Active in Reports: 06/05/2020	Last EDR Contact: 06/22/2020
Number of Days to Update: 73	Next Scheduled EDR Contact: 10/05/2020
	Data Release Frequency: Quarterly

ADDITIONAL ENVIRONMENTAL RECORDS

Local Brownfield lists

US BROWNFIELDS: A Listing of Brownfields Sites

Brownfields are real property, the expansion, redevelopment, or reuse of which may be complicated by the presence or potential presence of a hazardous substance, pollutant, or contaminant. Cleaning up and reinvesting in these properties takes development pressures off of undeveloped, open land, and both improves and protects the environment. Assessment, Cleanup and Redevelopment Exchange System (ACRES) stores information reported by EPA Brownfields grant recipients on brownfields properties assessed or cleaned up with grant funding as well as information on Targeted Brownfields Assessments performed by EPA Regions. A listing of ACRES Brownfield sites is obtained from Cleanups in My Community. Cleanups in My Community provides information on Brownfields properties for which information is reported back to EPA, as well as areas served by Brownfields grant programs.

Date of Government Version: 06/01/2020	Source: Environmental Protection Agency
Date Data Arrived at EDR: 06/02/2020	Telephone: 202-566-2777
Date Made Active in Reports: 06/09/2020	Last EDR Contact: 06/02/2020
Number of Days to Update: 7	Next Scheduled EDR Contact: 09/28/2020
	Data Release Frequency: Semi-Annually

Local Lists of Landfill / Solid Waste Disposal Sites

WMUDS/SWAT: Waste Management Unit Database

Waste Management Unit Database System. WMUDS is used by the State Water Resources Control Board staff and the Regional Water Quality Control Boards for program tracking and inventory of waste management units. WMUDS is composed of the following databases: Facility Information, Scheduled Inspections Information, Waste Management Unit Information, SWAT Program Information, SWAT Report Summary Information, SWAT Report Summary Data, Chapter 15 (formerly Subchapter 15) Information, Chapter 15 Monitoring Parameters, TPCA Program Information, RCRA Program Information, Closure Information, and Interested Parties Information.

GOVERNMENT RECORDS SEARCHED / DATA CURRENCY TRACKING

Date of Government Version: 04/01/2000
Date Data Arrived at EDR: 04/10/2000
Date Made Active in Reports: 05/10/2000
Number of Days to Update: 30

Source: State Water Resources Control Board
Telephone: 916-227-4448
Last EDR Contact: 07/21/2020
Next Scheduled EDR Contact: 11/09/2020
Data Release Frequency: No Update Planned

SWRCY: Recycler Database

A listing of recycling facilities in California.

Date of Government Version: 06/08/2020
Date Data Arrived at EDR: 06/09/2020
Date Made Active in Reports: 08/19/2020
Number of Days to Update: 71

Source: Department of Conservation
Telephone: 916-323-3836
Last EDR Contact: 06/09/2020
Next Scheduled EDR Contact: 09/21/2020
Data Release Frequency: Quarterly

HAULERS: Registered Waste Tire Haulers Listing

A listing of registered waste tire haulers.

Date of Government Version: 05/28/2020
Date Data Arrived at EDR: 05/29/2020
Date Made Active in Reports: 08/12/2020
Number of Days to Update: 75

Source: Integrated Waste Management Board
Telephone: 916-341-6422
Last EDR Contact: 08/04/2020
Next Scheduled EDR Contact: 11/23/2020
Data Release Frequency: Varies

INDIAN ODI: Report on the Status of Open Dumps on Indian Lands

Location of open dumps on Indian land.

Date of Government Version: 12/31/1998
Date Data Arrived at EDR: 12/03/2007
Date Made Active in Reports: 01/24/2008
Number of Days to Update: 52

Source: Environmental Protection Agency
Telephone: 703-308-8245
Last EDR Contact: 07/21/2020
Next Scheduled EDR Contact: 11/09/2020
Data Release Frequency: Varies

ODI: Open Dump Inventory

An open dump is defined as a disposal facility that does not comply with one or more of the Part 257 or Part 258 Subtitle D Criteria.

Date of Government Version: 06/30/1985
Date Data Arrived at EDR: 08/09/2004
Date Made Active in Reports: 09/17/2004
Number of Days to Update: 39

Source: Environmental Protection Agency
Telephone: 800-424-9346
Last EDR Contact: 06/09/2004
Next Scheduled EDR Contact: N/A
Data Release Frequency: No Update Planned

DEBRIS REGION 9: Torres Martinez Reservation Illegal Dump Site Locations

A listing of illegal dump sites location on the Torres Martinez Indian Reservation located in eastern Riverside County and northern Imperial County, California.

Date of Government Version: 01/12/2009
Date Data Arrived at EDR: 05/07/2009
Date Made Active in Reports: 09/21/2009
Number of Days to Update: 137

Source: EPA, Region 9
Telephone: 415-947-4219
Last EDR Contact: 07/14/2020
Next Scheduled EDR Contact: 11/02/2020
Data Release Frequency: No Update Planned

IHS OPEN DUMPS: Open Dumps on Indian Land

A listing of all open dumps located on Indian Land in the United States.

Date of Government Version: 04/01/2014
Date Data Arrived at EDR: 08/06/2014
Date Made Active in Reports: 01/29/2015
Number of Days to Update: 176

Source: Department of Health & Human Services, Indian Health Service
Telephone: 301-443-1452
Last EDR Contact: 07/31/2020
Next Scheduled EDR Contact: 11/09/2020
Data Release Frequency: Varies

GOVERNMENT RECORDS SEARCHED / DATA CURRENCY TRACKING

Local Lists of Hazardous waste / Contaminated Sites

US HIST CDL: National Clandestine Laboratory Register

A listing of clandestine drug lab locations that have been removed from the DEAs National Clandestine Laboratory Register.

Date of Government Version: 03/18/2020	Source: Drug Enforcement Administration
Date Data Arrived at EDR: 03/19/2020	Telephone: 202-307-1000
Date Made Active in Reports: 06/09/2020	Last EDR Contact: 08/19/2020
Number of Days to Update: 82	Next Scheduled EDR Contact: 12/07/2020
	Data Release Frequency: No Update Planned

HIST CAL-SITES: Calsites Database

The Calsites database contains potential or confirmed hazardous substance release properties. In 1996, California EPA reevaluated and significantly reduced the number of sites in the Calsites database. No longer updated by the state agency. It has been replaced by ENVIROSTOR.

Date of Government Version: 08/08/2005	Source: Department of Toxic Substance Control
Date Data Arrived at EDR: 08/03/2006	Telephone: 916-323-3400
Date Made Active in Reports: 08/24/2006	Last EDR Contact: 02/23/2009
Number of Days to Update: 21	Next Scheduled EDR Contact: 05/25/2009
	Data Release Frequency: No Update Planned

SCH: School Property Evaluation Program

This category contains proposed and existing school sites that are being evaluated by DTSC for possible hazardous materials contamination. In some cases, these properties may be listed in the CalSites category depending on the level of threat to public health and safety or the environment they pose.

Date of Government Version: 04/27/2020	Source: Department of Toxic Substances Control
Date Data Arrived at EDR: 04/28/2020	Telephone: 916-323-3400
Date Made Active in Reports: 07/13/2020	Last EDR Contact: 07/27/2020
Number of Days to Update: 76	Next Scheduled EDR Contact: 11/09/2020
	Data Release Frequency: Quarterly

CDL: Clandestine Drug Labs

A listing of drug lab locations. Listing of a location in this database does not indicate that any illegal drug lab materials were or were not present there, and does not constitute a determination that the location either requires or does not require additional cleanup work.

Date of Government Version: 06/30/2019	Source: Department of Toxic Substances Control
Date Data Arrived at EDR: 05/28/2020	Telephone: 916-255-6504
Date Made Active in Reports: 08/12/2020	Last EDR Contact: 07/09/2020
Number of Days to Update: 76	Next Scheduled EDR Contact: 10/19/2020
	Data Release Frequency: Varies

TOXIC PITS: Toxic Pits Cleanup Act Sites

Toxic PITS Cleanup Act Sites. TOXIC PITS identifies sites suspected of containing hazardous substances where cleanup has not yet been completed.

Date of Government Version: 07/01/1995	Source: State Water Resources Control Board
Date Data Arrived at EDR: 08/30/1995	Telephone: 916-227-4364
Date Made Active in Reports: 09/26/1995	Last EDR Contact: 01/26/2009
Number of Days to Update: 27	Next Scheduled EDR Contact: 04/27/2009
	Data Release Frequency: No Update Planned

CERS HAZ WASTE: CERS HAZ WASTE

List of sites in the California Environmental Protection Agency (CalEPA) Regulated Site Portal which fall under the Hazardous Chemical Management, Hazardous Waste Onsite Treatment, Household Hazardous Waste Collection, Hazardous Waste Generator, and RCRA LQ HW Generator programs.

GOVERNMENT RECORDS SEARCHED / DATA CURRENCY TRACKING

Date of Government Version: 04/20/2020
Date Data Arrived at EDR: 04/21/2020
Date Made Active in Reports: 07/13/2020
Number of Days to Update: 83

Source: CalEPA
Telephone: 916-323-2514
Last EDR Contact: 07/21/2020
Next Scheduled EDR Contact: 11/02/2020
Data Release Frequency: Quarterly

US CDL: Clandestine Drug Labs

A listing of clandestine drug lab locations. The U.S. Department of Justice ("the Department") provides this web site as a public service. It contains addresses of some locations where law enforcement agencies reported they found chemicals or other items that indicated the presence of either clandestine drug laboratories or dumpsites. In most cases, the source of the entries is not the Department, and the Department has not verified the entry and does not guarantee its accuracy. Members of the public must verify the accuracy of all entries by, for example, contacting local law enforcement and local health departments.

Date of Government Version: 03/18/2020
Date Data Arrived at EDR: 03/19/2020
Date Made Active in Reports: 06/09/2020
Number of Days to Update: 82

Source: Drug Enforcement Administration
Telephone: 202-307-1000
Last EDR Contact: 08/19/2020
Next Scheduled EDR Contact: 12/07/2020
Data Release Frequency: Quarterly

PFAS: PFAS Contamination Site Location Listing

A listing of PFAS contaminated sites included in the GeoTracker database.

Date of Government Version: 06/08/2020
Date Data Arrived at EDR: 06/09/2020
Date Made Active in Reports: 08/19/2020
Number of Days to Update: 71

Source: State Water Resources Control Board
Telephone: 866-480-1028
Last EDR Contact: 06/09/2020
Next Scheduled EDR Contact: 09/21/2020
Data Release Frequency: Varies

Local Lists of Registered Storage Tanks

SWEEPS UST: SWEEPS UST Listing

Statewide Environmental Evaluation and Planning System. This underground storage tank listing was updated and maintained by a company contacted by the SWRCB in the early 1990's. The listing is no longer updated or maintained. The local agency is the contact for more information on a site on the SWEEPS list.

Date of Government Version: 06/01/1994
Date Data Arrived at EDR: 07/07/2005
Date Made Active in Reports: 08/11/2005
Number of Days to Update: 35

Source: State Water Resources Control Board
Telephone: N/A
Last EDR Contact: 06/03/2005
Next Scheduled EDR Contact: N/A
Data Release Frequency: No Update Planned

UST MENDOCINO: Mendocino County UST Database

A listing of underground storage tank locations in Mendocino County.

Date of Government Version: 05/20/2020
Date Data Arrived at EDR: 05/20/2020
Date Made Active in Reports: 08/06/2020
Number of Days to Update: 78

Source: Department of Public Health
Telephone: 707-463-4466
Last EDR Contact: 08/17/2020
Next Scheduled EDR Contact: 12/07/2020
Data Release Frequency: Annually

HIST UST: Hazardous Substance Storage Container Database

The Hazardous Substance Storage Container Database is a historical listing of UST sites. Refer to local/county source for current data.

Date of Government Version: 10/15/1990
Date Data Arrived at EDR: 01/25/1991
Date Made Active in Reports: 02/12/1991
Number of Days to Update: 18

Source: State Water Resources Control Board
Telephone: 916-341-5851
Last EDR Contact: 07/26/2001
Next Scheduled EDR Contact: N/A
Data Release Frequency: No Update Planned

GOVERNMENT RECORDS SEARCHED / DATA CURRENCY TRACKING

SAN FRANCISCO AST: Aboveground Storage Tank Site Listing Aboveground storage tank sites

Date of Government Version: 05/04/2020	Source: San Francisco County Department of Public Health
Date Data Arrived at EDR: 05/06/2020	Telephone: 415-252-3896
Date Made Active in Reports: 07/17/2020	Last EDR Contact: 07/28/2020
Number of Days to Update: 72	Next Scheduled EDR Contact: 11/16/2020
	Data Release Frequency: Varies

CA FID UST: Facility Inventory Database

The Facility Inventory Database (FID) contains a historical listing of active and inactive underground storage tank locations from the State Water Resource Control Board. Refer to local/county source for current data.

Date of Government Version: 10/31/1994	Source: California Environmental Protection Agency
Date Data Arrived at EDR: 09/05/1995	Telephone: 916-341-5851
Date Made Active in Reports: 09/29/1995	Last EDR Contact: 12/28/1998
Number of Days to Update: 24	Next Scheduled EDR Contact: N/A
	Data Release Frequency: No Update Planned

CERS TANKS: California Environmental Reporting System (CERS) Tanks

List of sites in the California Environmental Protection Agency (CalEPA) Regulated Site Portal which fall under the Aboveground Petroleum Storage and Underground Storage Tank regulatory programs.

Date of Government Version: 04/20/2020	Source: California Environmental Protection Agency
Date Data Arrived at EDR: 04/21/2020	Telephone: 916-323-2514
Date Made Active in Reports: 07/09/2020	Last EDR Contact: 07/21/2020
Number of Days to Update: 79	Next Scheduled EDR Contact: 11/02/2020
	Data Release Frequency: Quarterly

Local Land Records

LIENS: Environmental Liens Listing

A listing of property locations with environmental liens for California where DTSC is a lien holder.

Date of Government Version: 05/28/2020	Source: Department of Toxic Substances Control
Date Data Arrived at EDR: 05/29/2020	Telephone: 916-323-3400
Date Made Active in Reports: 08/12/2020	Last EDR Contact: 08/25/2020
Number of Days to Update: 75	Next Scheduled EDR Contact: 12/14/2020
	Data Release Frequency: Varies

LIENS 2: CERCLA Lien Information

A Federal CERCLA ('Superfund') lien can exist by operation of law at any site or property at which EPA has spent Superfund monies. These monies are spent to investigate and address releases and threatened releases of contamination. CERCLIS provides information as to the identity of these sites and properties.

Date of Government Version: 07/29/2020	Source: Environmental Protection Agency
Date Data Arrived at EDR: 08/03/2020	Telephone: 202-564-6023
Date Made Active in Reports: 08/25/2020	Last EDR Contact: 08/03/2020
Number of Days to Update: 22	Next Scheduled EDR Contact: 10/12/2020
	Data Release Frequency: Semi-Annually

DEED: Deed Restriction Listing

GOVERNMENT RECORDS SEARCHED / DATA CURRENCY TRACKING

Site Mitigation and Brownfields Reuse Program Facility Sites with Deed Restrictions & Hazardous Waste Management Program Facility Sites with Deed / Land Use Restriction. The DTSC Site Mitigation and Brownfields Reuse Program (SMBRP) list includes sites cleaned up under the program's oversight and generally does not include current or former hazardous waste facilities that required a hazardous waste facility permit. The list represents deed restrictions that are active. Some sites have multiple deed restrictions. The DTSC Hazardous Waste Management Program (HWMP) has developed a list of current or former hazardous waste facilities that have a recorded land use restriction at the local county recorder's office. The land use restrictions on this list were required by the DTSC HWMP as a result of the presence of hazardous substances that remain on site after the facility (or part of the facility) has been closed or cleaned up. The types of land use restriction include deed notice, deed restriction, or a land use restriction that binds current and future owners.

Date of Government Version: 06/01/2020	Source: DTSC and SWRCB
Date Data Arrived at EDR: 06/02/2020	Telephone: 916-323-3400
Date Made Active in Reports: 08/14/2020	Last EDR Contact: 06/02/2020
Number of Days to Update: 73	Next Scheduled EDR Contact: 09/14/2020
	Data Release Frequency: Semi-Annually

Records of Emergency Release Reports

HMIRS: Hazardous Materials Information Reporting System

Hazardous Materials Incident Report System. HMIRS contains hazardous material spill incidents reported to DOT.

Date of Government Version: 02/27/2020	Source: U.S. Department of Transportation
Date Data Arrived at EDR: 03/24/2020	Telephone: 202-366-4555
Date Made Active in Reports: 06/18/2020	Last EDR Contact: 06/23/2020
Number of Days to Update: 86	Next Scheduled EDR Contact: 10/05/2020
	Data Release Frequency: Quarterly

CHMIRS: California Hazardous Material Incident Report System

California Hazardous Material Incident Reporting System. CHMIRS contains information on reported hazardous material incidents (accidental releases or spills).

Date of Government Version: 03/31/2020	Source: Office of Emergency Services
Date Data Arrived at EDR: 04/21/2020	Telephone: 916-845-8400
Date Made Active in Reports: 07/09/2020	Last EDR Contact: 07/21/2020
Number of Days to Update: 79	Next Scheduled EDR Contact: 11/02/2020
	Data Release Frequency: Semi-Annually

LDS: Land Disposal Sites Listing (GEOTRACKER)

Land Disposal sites (Landfills) included in GeoTracker. GeoTracker is the Water Boards data management system for sites that impact, or have the potential to impact, water quality in California, with emphasis on groundwater.

Date of Government Version: 06/08/2020	Source: State Water Quality Control Board
Date Data Arrived at EDR: 06/09/2020	Telephone: 866-480-1028
Date Made Active in Reports: 08/19/2020	Last EDR Contact: 06/09/2020
Number of Days to Update: 71	Next Scheduled EDR Contact: 09/21/2020
	Data Release Frequency: Quarterly

MCS: Military Cleanup Sites Listing (GEOTRACKER)

Military sites (consisting of: Military UST sites; Military Privatized sites; and Military Cleanup sites [formerly known as DoD non UST]) included in GeoTracker. GeoTracker is the Water Boards data management system for sites that impact, or have the potential to impact, water quality in California, with emphasis on groundwater.

Date of Government Version: 06/08/2020	Source: State Water Resources Control Board
Date Data Arrived at EDR: 06/09/2020	Telephone: 866-480-1028
Date Made Active in Reports: 08/19/2020	Last EDR Contact: 06/09/2020
Number of Days to Update: 71	Next Scheduled EDR Contact: 09/21/2020
	Data Release Frequency: Quarterly

GOVERNMENT RECORDS SEARCHED / DATA CURRENCY TRACKING

SPILLS 90: SPILLS90 data from FirstSearch

Spills 90 includes those spill and release records available exclusively from FirstSearch databases. Typically, they may include chemical, oil and/or hazardous substance spills recorded after 1990. Duplicate records that are already included in EDR incident and release records are not included in Spills 90.

Date of Government Version: 06/06/2012	Source: FirstSearch
Date Data Arrived at EDR: 01/03/2013	Telephone: N/A
Date Made Active in Reports: 02/22/2013	Last EDR Contact: 01/03/2013
Number of Days to Update: 50	Next Scheduled EDR Contact: N/A
	Data Release Frequency: No Update Planned

Other Ascertainable Records

RCRA NonGen / NLR: RCRA - Non Generators / No Longer Regulated

RCRAInfo is EPA's comprehensive information system, providing access to data supporting the Resource Conservation and Recovery Act (RCRA) of 1976 and the Hazardous and Solid Waste Amendments (HSWA) of 1984. The database includes selective information on sites which generate, transport, store, treat and/or dispose of hazardous waste as defined by the Resource Conservation and Recovery Act (RCRA). Non-Generators do not presently generate hazardous waste.

Date of Government Version: 03/23/2020	Source: Environmental Protection Agency
Date Data Arrived at EDR: 03/25/2020	Telephone: (415) 495-8895
Date Made Active in Reports: 05/21/2020	Last EDR Contact: 06/22/2020
Number of Days to Update: 57	Next Scheduled EDR Contact: 10/05/2020
	Data Release Frequency: Quarterly

FUDS: Formerly Used Defense Sites

The listing includes locations of Formerly Used Defense Sites properties where the US Army Corps of Engineers is actively working or will take necessary cleanup actions.

Date of Government Version: 05/13/2020	Source: U.S. Army Corps of Engineers
Date Data Arrived at EDR: 05/18/2020	Telephone: 202-528-4285
Date Made Active in Reports: 08/12/2020	Last EDR Contact: 08/13/2020
Number of Days to Update: 86	Next Scheduled EDR Contact: 11/30/2020
	Data Release Frequency: Varies

DOD: Department of Defense Sites

This data set consists of federally owned or administered lands, administered by the Department of Defense, that have any area equal to or greater than 640 acres of the United States, Puerto Rico, and the U.S. Virgin Islands.

Date of Government Version: 12/31/2005	Source: USGS
Date Data Arrived at EDR: 11/10/2006	Telephone: 888-275-8747
Date Made Active in Reports: 01/11/2007	Last EDR Contact: 07/09/2020
Number of Days to Update: 62	Next Scheduled EDR Contact: 10/19/2020
	Data Release Frequency: Semi-Annually

FEDLAND: Federal and Indian Lands

Federally and Indian administrated lands of the United States. Lands included are administrated by: Army Corps of Engineers, Bureau of Reclamation, National Wild and Scenic River, National Wildlife Refuge, Public Domain Land, Wilderness, Wilderness Study Area, Wildlife Management Area, Bureau of Indian Affairs, Bureau of Land Management, Department of Justice, Forest Service, Fish and Wildlife Service, National Park Service.

Date of Government Version: 04/02/2018	Source: U.S. Geological Survey
Date Data Arrived at EDR: 04/11/2018	Telephone: 888-275-8747
Date Made Active in Reports: 11/06/2019	Last EDR Contact: 07/06/2020
Number of Days to Update: 574	Next Scheduled EDR Contact: 10/19/2020
	Data Release Frequency: N/A

SCRD DRYCLEANERS: State Coalition for Remediation of Drycleaners Listing

The State Coalition for Remediation of Drycleaners was established in 1998, with support from the U.S. EPA Office of Superfund Remediation and Technology Innovation. It is comprised of representatives of states with established drycleaner remediation programs. Currently the member states are Alabama, Connecticut, Florida, Illinois, Kansas, Minnesota, Missouri, North Carolina, Oregon, South Carolina, Tennessee, Texas, and Wisconsin.

GOVERNMENT RECORDS SEARCHED / DATA CURRENCY TRACKING

Date of Government Version: 01/01/2017
Date Data Arrived at EDR: 02/03/2017
Date Made Active in Reports: 04/07/2017
Number of Days to Update: 63

Source: Environmental Protection Agency
Telephone: 615-532-8599
Last EDR Contact: 08/05/2020
Next Scheduled EDR Contact: 11/23/2020
Data Release Frequency: Varies

US FIN ASSUR: Financial Assurance Information

All owners and operators of facilities that treat, store, or dispose of hazardous waste are required to provide proof that they will have sufficient funds to pay for the clean up, closure, and post-closure care of their facilities.

Date of Government Version: 03/23/2020
Date Data Arrived at EDR: 03/24/2020
Date Made Active in Reports: 06/18/2020
Number of Days to Update: 86

Source: Environmental Protection Agency
Telephone: 202-566-1917
Last EDR Contact: 06/22/2020
Next Scheduled EDR Contact: 10/05/2020
Data Release Frequency: Quarterly

EPA WATCH LIST: EPA WATCH LIST

EPA maintains a "Watch List" to facilitate dialogue between EPA, state and local environmental agencies on enforcement matters relating to facilities with alleged violations identified as either significant or high priority. Being on the Watch List does not mean that the facility has actually violated the law only that an investigation by EPA or a state or local environmental agency has led those organizations to allege that an unproven violation has in fact occurred. Being on the Watch List does not represent a higher level of concern regarding the alleged violations that were detected, but instead indicates cases requiring additional dialogue between EPA, state and local agencies - primarily because of the length of time the alleged violation has gone unaddressed or unresolved.

Date of Government Version: 08/30/2013
Date Data Arrived at EDR: 03/21/2014
Date Made Active in Reports: 06/17/2014
Number of Days to Update: 88

Source: Environmental Protection Agency
Telephone: 617-520-3000
Last EDR Contact: 07/31/2020
Next Scheduled EDR Contact: 11/16/2020
Data Release Frequency: Quarterly

2020 COR ACTION: 2020 Corrective Action Program List

The EPA has set ambitious goals for the RCRA Corrective Action program by creating the 2020 Corrective Action Universe. This RCRA cleanup baseline includes facilities expected to need corrective action. The 2020 universe contains a wide variety of sites. Some properties are heavily contaminated while others were contaminated but have since been cleaned up. Still others have not been fully investigated yet, and may require little or no remediation. Inclusion in the 2020 Universe does not necessarily imply failure on the part of a facility to meet its RCRA obligations.

Date of Government Version: 09/30/2017
Date Data Arrived at EDR: 05/08/2018
Date Made Active in Reports: 07/20/2018
Number of Days to Update: 73

Source: Environmental Protection Agency
Telephone: 703-308-4044
Last EDR Contact: 08/06/2020
Next Scheduled EDR Contact: 11/16/2020
Data Release Frequency: Varies

TSCA: Toxic Substances Control Act

Toxic Substances Control Act. TSCA identifies manufacturers and importers of chemical substances included on the TSCA Chemical Substance Inventory list. It includes data on the production volume of these substances by plant site.

Date of Government Version: 12/31/2016
Date Data Arrived at EDR: 06/21/2017
Date Made Active in Reports: 01/05/2018
Number of Days to Update: 198

Source: EPA
Telephone: 202-260-5521
Last EDR Contact: 06/17/2020
Next Scheduled EDR Contact: 09/28/2020
Data Release Frequency: Every 4 Years

TRIS: Toxic Chemical Release Inventory System

Toxic Release Inventory System. TRIS identifies facilities which release toxic chemicals to the air, water and land in reportable quantities under SARA Title III Section 313.

GOVERNMENT RECORDS SEARCHED / DATA CURRENCY TRACKING

Date of Government Version: 12/31/2018
Date Data Arrived at EDR: 02/05/2020
Date Made Active in Reports: 04/24/2020
Number of Days to Update: 79

Source: EPA
Telephone: 202-566-0250
Last EDR Contact: 08/14/2020
Next Scheduled EDR Contact: 11/30/2020
Data Release Frequency: Annually

SSTS: Section 7 Tracking Systems

Section 7 of the Federal Insecticide, Fungicide and Rodenticide Act, as amended (92 Stat. 829) requires all registered pesticide-producing establishments to submit a report to the Environmental Protection Agency by March 1st each year. Each establishment must report the types and amounts of pesticides, active ingredients and devices being produced, and those having been produced and sold or distributed in the past year.

Date of Government Version: 03/01/2020
Date Data Arrived at EDR: 04/21/2020
Date Made Active in Reports: 07/15/2020
Number of Days to Update: 85

Source: EPA
Telephone: 202-564-4203
Last EDR Contact: 07/21/2020
Next Scheduled EDR Contact: 11/02/2020
Data Release Frequency: Annually

ROD: Records Of Decision

Record of Decision. ROD documents mandate a permanent remedy at an NPL (Superfund) site containing technical and health information to aid in the cleanup.

Date of Government Version: 07/29/2020
Date Data Arrived at EDR: 08/03/2020
Date Made Active in Reports: 08/25/2020
Number of Days to Update: 22

Source: EPA
Telephone: 703-416-0223
Last EDR Contact: 08/03/2020
Next Scheduled EDR Contact: 09/14/2020
Data Release Frequency: Annually

RMP: Risk Management Plans

When Congress passed the Clean Air Act Amendments of 1990, it required EPA to publish regulations and guidance for chemical accident prevention at facilities using extremely hazardous substances. The Risk Management Program Rule (RMP Rule) was written to implement Section 112(r) of these amendments. The rule, which built upon existing industry codes and standards, requires companies of all sizes that use certain flammable and toxic substances to develop a Risk Management Program, which includes a(n): Hazard assessment that details the potential effects of an accidental release, an accident history of the last five years, and an evaluation of worst-case and alternative accidental releases; Prevention program that includes safety precautions and maintenance, monitoring, and employee training measures; and Emergency response program that spells out emergency health care, employee training measures and procedures for informing the public and response agencies (e.g the fire department) should an accident occur.

Date of Government Version: 01/31/2020
Date Data Arrived at EDR: 05/13/2020
Date Made Active in Reports: 08/03/2020
Number of Days to Update: 82

Source: Environmental Protection Agency
Telephone: 202-564-8600
Last EDR Contact: 07/15/2020
Next Scheduled EDR Contact: 11/02/2020
Data Release Frequency: Varies

RAATS: RCRA Administrative Action Tracking System

RCRA Administration Action Tracking System. RAATS contains records based on enforcement actions issued under RCRA pertaining to major violators and includes administrative and civil actions brought by the EPA. For administration actions after September 30, 1995, data entry in the RAATS database was discontinued. EPA will retain a copy of the database for historical records. It was necessary to terminate RAATS because a decrease in agency resources made it impossible to continue to update the information contained in the database.

Date of Government Version: 04/17/1995
Date Data Arrived at EDR: 07/03/1995
Date Made Active in Reports: 08/07/1995
Number of Days to Update: 35

Source: EPA
Telephone: 202-564-4104
Last EDR Contact: 06/02/2008
Next Scheduled EDR Contact: 09/01/2008
Data Release Frequency: No Update Planned

GOVERNMENT RECORDS SEARCHED / DATA CURRENCY TRACKING

PRP: Potentially Responsible Parties

A listing of verified Potentially Responsible Parties

Date of Government Version: 04/27/2020	Source: EPA
Date Data Arrived at EDR: 05/06/2020	Telephone: 202-564-6023
Date Made Active in Reports: 06/09/2020	Last EDR Contact: 08/03/2020
Number of Days to Update: 34	Next Scheduled EDR Contact: 11/16/2020
	Data Release Frequency: Quarterly

PADS: PCB Activity Database System

PCB Activity Database. PADS Identifies generators, transporters, commercial storers and/or brokers and disposers of PCB's who are required to notify the EPA of such activities.

Date of Government Version: 10/09/2019	Source: EPA
Date Data Arrived at EDR: 10/11/2019	Telephone: 202-566-0500
Date Made Active in Reports: 12/20/2019	Last EDR Contact: 07/13/2020
Number of Days to Update: 70	Next Scheduled EDR Contact: 10/19/2020
	Data Release Frequency: Annually

ICIS: Integrated Compliance Information System

The Integrated Compliance Information System (ICIS) supports the information needs of the national enforcement and compliance program as well as the unique needs of the National Pollutant Discharge Elimination System (NPDES) program.

Date of Government Version: 11/18/2016	Source: Environmental Protection Agency
Date Data Arrived at EDR: 11/23/2016	Telephone: 202-564-2501
Date Made Active in Reports: 02/10/2017	Last EDR Contact: 06/30/2020
Number of Days to Update: 79	Next Scheduled EDR Contact: 10/19/2020
	Data Release Frequency: Quarterly

FTTS: FIFRA/ TSCA Tracking System - FIFRA (Federal Insecticide, Fungicide, & Rodenticide Act)/TSCA (Toxic Substances Control Act)

FTTS tracks administrative cases and pesticide enforcement actions and compliance activities related to FIFRA, TSCA and EPCRA (Emergency Planning and Community Right-to-Know Act). To maintain currency, EDR contacts the Agency on a quarterly basis.

Date of Government Version: 04/09/2009	Source: EPA/Office of Prevention, Pesticides and Toxic Substances
Date Data Arrived at EDR: 04/16/2009	Telephone: 202-566-1667
Date Made Active in Reports: 05/11/2009	Last EDR Contact: 08/18/2017
Number of Days to Update: 25	Next Scheduled EDR Contact: 12/04/2017
	Data Release Frequency: No Update Planned

FTTS INSP: FIFRA/ TSCA Tracking System - FIFRA (Federal Insecticide, Fungicide, & Rodenticide Act)/TSCA (Toxic Substances Control Act)

A listing of FIFRA/TSCA Tracking System (FTTS) inspections and enforcements.

Date of Government Version: 04/09/2009	Source: EPA
Date Data Arrived at EDR: 04/16/2009	Telephone: 202-566-1667
Date Made Active in Reports: 05/11/2009	Last EDR Contact: 08/18/2017
Number of Days to Update: 25	Next Scheduled EDR Contact: 12/04/2017
	Data Release Frequency: No Update Planned

MLTS: Material Licensing Tracking System

MLTS is maintained by the Nuclear Regulatory Commission and contains a list of approximately 8,100 sites which possess or use radioactive materials and which are subject to NRC licensing requirements. To maintain currency, EDR contacts the Agency on a quarterly basis.

Date of Government Version: 10/25/2019	Source: Nuclear Regulatory Commission
Date Data Arrived at EDR: 10/25/2019	Telephone: 301-415-7169
Date Made Active in Reports: 01/15/2020	Last EDR Contact: 07/20/2020
Number of Days to Update: 82	Next Scheduled EDR Contact: 11/02/2020
	Data Release Frequency: Quarterly

GOVERNMENT RECORDS SEARCHED / DATA CURRENCY TRACKING

COAL ASH DOE: Steam-Electric Plant Operation Data

A listing of power plants that store ash in surface ponds.

Date of Government Version: 12/31/2018	Source: Department of Energy
Date Data Arrived at EDR: 12/04/2019	Telephone: 202-586-8719
Date Made Active in Reports: 01/15/2020	Last EDR Contact: 06/05/2020
Number of Days to Update: 42	Next Scheduled EDR Contact: 09/14/2020
	Data Release Frequency: Varies

COAL ASH EPA: Coal Combustion Residues Surface Impoundments List

A listing of coal combustion residues surface impoundments with high hazard potential ratings.

Date of Government Version: 01/12/2017	Source: Environmental Protection Agency
Date Data Arrived at EDR: 03/05/2019	Telephone: N/A
Date Made Active in Reports: 11/11/2019	Last EDR Contact: 06/01/2020
Number of Days to Update: 251	Next Scheduled EDR Contact: 09/14/2020
	Data Release Frequency: Varies

PCB TRANSFORMER: PCB Transformer Registration Database

The database of PCB transformer registrations that includes all PCB registration submittals.

Date of Government Version: 09/13/2019	Source: Environmental Protection Agency
Date Data Arrived at EDR: 11/06/2019	Telephone: 202-566-0517
Date Made Active in Reports: 02/10/2020	Last EDR Contact: 08/06/2020
Number of Days to Update: 96	Next Scheduled EDR Contact: 11/16/2020
	Data Release Frequency: Varies

RADINFO: Radiation Information Database

The Radiation Information Database (RADINFO) contains information about facilities that are regulated by U.S. Environmental Protection Agency (EPA) regulations for radiation and radioactivity.

Date of Government Version: 07/01/2019	Source: Environmental Protection Agency
Date Data Arrived at EDR: 07/01/2019	Telephone: 202-343-9775
Date Made Active in Reports: 09/23/2019	Last EDR Contact: 06/24/2020
Number of Days to Update: 84	Next Scheduled EDR Contact: 10/12/2020
	Data Release Frequency: Quarterly

HIST FTTS: FIFRA/TSCA Tracking System Administrative Case Listing

A complete administrative case listing from the FIFRA/TSCA Tracking System (FTTS) for all ten EPA regions. The information was obtained from the National Compliance Database (NCDB). NCDB supports the implementation of FIFRA (Federal Insecticide, Fungicide, and Rodenticide Act) and TSCA (Toxic Substances Control Act). Some EPA regions are now closing out records. Because of that, and the fact that some EPA regions are not providing EPA Headquarters with updated records, it was decided to create a HIST FTTS database. It included records that may not be included in the newer FTTS database updates. This database is no longer updated.

Date of Government Version: 10/19/2006	Source: Environmental Protection Agency
Date Data Arrived at EDR: 03/01/2007	Telephone: 202-564-2501
Date Made Active in Reports: 04/10/2007	Last EDR Contact: 12/17/2007
Number of Days to Update: 40	Next Scheduled EDR Contact: 03/17/2008
	Data Release Frequency: No Update Planned

HIST FTTS INSP: FIFRA/TSCA Tracking System Inspection & Enforcement Case Listing

A complete inspection and enforcement case listing from the FIFRA/TSCA Tracking System (FTTS) for all ten EPA regions. The information was obtained from the National Compliance Database (NCDB). NCDB supports the implementation of FIFRA (Federal Insecticide, Fungicide, and Rodenticide Act) and TSCA (Toxic Substances Control Act). Some EPA regions are now closing out records. Because of that, and the fact that some EPA regions are not providing EPA Headquarters with updated records, it was decided to create a HIST FTTS database. It included records that may not be included in the newer FTTS database updates. This database is no longer updated.

GOVERNMENT RECORDS SEARCHED / DATA CURRENCY TRACKING

Date of Government Version: 10/19/2006
Date Data Arrived at EDR: 03/01/2007
Date Made Active in Reports: 04/10/2007
Number of Days to Update: 40

Source: Environmental Protection Agency
Telephone: 202-564-2501
Last EDR Contact: 12/17/2008
Next Scheduled EDR Contact: 03/17/2008
Data Release Frequency: No Update Planned

DOT OPS: Incident and Accident Data

Department of Transportation, Office of Pipeline Safety Incident and Accident data.

Date of Government Version: 01/02/2020
Date Data Arrived at EDR: 01/28/2020
Date Made Active in Reports: 04/17/2020
Number of Days to Update: 80

Source: Department of Transportation, Office of Pipeline Safety
Telephone: 202-366-4595
Last EDR Contact: 07/27/2020
Next Scheduled EDR Contact: 11/09/2020
Data Release Frequency: Quarterly

CONSENT: Superfund (CERCLA) Consent Decrees

Major legal settlements that establish responsibility and standards for cleanup at NPL (Superfund) sites. Released periodically by United States District Courts after settlement by parties to litigation matters.

Date of Government Version: 06/30/2020
Date Data Arrived at EDR: 07/15/2020
Date Made Active in Reports: 07/21/2020
Number of Days to Update: 6

Source: Department of Justice, Consent Decree Library
Telephone: Varies
Last EDR Contact: 07/06/2020
Next Scheduled EDR Contact: 10/19/2020
Data Release Frequency: Varies

BRS: Biennial Reporting System

The Biennial Reporting System is a national system administered by the EPA that collects data on the generation and management of hazardous waste. BRS captures detailed data from two groups: Large Quantity Generators (LQG) and Treatment, Storage, and Disposal Facilities.

Date of Government Version: 12/31/2015
Date Data Arrived at EDR: 02/22/2017
Date Made Active in Reports: 09/28/2017
Number of Days to Update: 218

Source: EPA/NTIS
Telephone: 800-424-9346
Last EDR Contact: 06/22/2020
Next Scheduled EDR Contact: 10/05/2020
Data Release Frequency: Biennially

INDIAN RESERV: Indian Reservations

This map layer portrays Indian administered lands of the United States that have any area equal to or greater than 640 acres.

Date of Government Version: 12/31/2014
Date Data Arrived at EDR: 07/14/2015
Date Made Active in Reports: 01/10/2017
Number of Days to Update: 546

Source: USGS
Telephone: 202-208-3710
Last EDR Contact: 07/07/2020
Next Scheduled EDR Contact: 10/19/2020
Data Release Frequency: Semi-Annually

FUSRAP: Formerly Utilized Sites Remedial Action Program

DOE established the Formerly Utilized Sites Remedial Action Program (FUSRAP) in 1974 to remediate sites where radioactive contamination remained from Manhattan Project and early U.S. Atomic Energy Commission (AEC) operations.

Date of Government Version: 08/08/2017
Date Data Arrived at EDR: 09/11/2018
Date Made Active in Reports: 09/14/2018
Number of Days to Update: 3

Source: Department of Energy
Telephone: 202-586-3559
Last EDR Contact: 07/28/2020
Next Scheduled EDR Contact: 11/16/2020
Data Release Frequency: Varies

UMTRA: Uranium Mill Tailings Sites

Uranium ore was mined by private companies for federal government use in national defense programs. When the mills shut down, large piles of the sand-like material (mill tailings) remain after uranium has been extracted from the ore. Levels of human exposure to radioactive materials from the piles are low; however, in some cases tailings were used as construction materials before the potential health hazards of the tailings were recognized.

GOVERNMENT RECORDS SEARCHED / DATA CURRENCY TRACKING

Date of Government Version: 08/30/2019
Date Data Arrived at EDR: 11/15/2019
Date Made Active in Reports: 01/28/2020
Number of Days to Update: 74

Source: Department of Energy
Telephone: 505-845-0011
Last EDR Contact: 08/21/2020
Next Scheduled EDR Contact: 11/30/2020
Data Release Frequency: Varies

LEAD SMELTER 1: Lead Smelter Sites

A listing of former lead smelter site locations.

Date of Government Version: 07/29/2020
Date Data Arrived at EDR: 08/03/2020
Date Made Active in Reports: 08/25/2020
Number of Days to Update: 22

Source: Environmental Protection Agency
Telephone: 703-603-8787
Last EDR Contact: 08/03/2020
Next Scheduled EDR Contact: 10/12/2020
Data Release Frequency: Varies

LEAD SMELTER 2: Lead Smelter Sites

A list of several hundred sites in the U.S. where secondary lead smelting was done from 1931 and 1964. These sites may pose a threat to public health through ingestion or inhalation of contaminated soil or dust

Date of Government Version: 04/05/2001
Date Data Arrived at EDR: 10/27/2010
Date Made Active in Reports: 12/02/2010
Number of Days to Update: 36

Source: American Journal of Public Health
Telephone: 703-305-6451
Last EDR Contact: 12/02/2009
Next Scheduled EDR Contact: N/A
Data Release Frequency: No Update Planned

US AIRS (AFS): Aerometric Information Retrieval System Facility Subsystem (AFS)

The database is a sub-system of Aerometric Information Retrieval System (AIRS). AFS contains compliance data on air pollution point sources regulated by the U.S. EPA and/or state and local air regulatory agencies. This information comes from source reports by various stationary sources of air pollution, such as electric power plants, steel mills, factories, and universities, and provides information about the air pollutants they produce. Action, air program, air program pollutant, and general level plant data. It is used to track emissions and compliance data from industrial plants.

Date of Government Version: 10/12/2016
Date Data Arrived at EDR: 10/26/2016
Date Made Active in Reports: 02/03/2017
Number of Days to Update: 100

Source: EPA
Telephone: 202-564-2496
Last EDR Contact: 09/26/2017
Next Scheduled EDR Contact: 01/08/2018
Data Release Frequency: Annually

US AIRS MINOR: Air Facility System Data

A listing of minor source facilities.

Date of Government Version: 10/12/2016
Date Data Arrived at EDR: 10/26/2016
Date Made Active in Reports: 02/03/2017
Number of Days to Update: 100

Source: EPA
Telephone: 202-564-2496
Last EDR Contact: 09/26/2017
Next Scheduled EDR Contact: 01/08/2018
Data Release Frequency: Annually

US MINES: Mines Master Index File

Contains all mine identification numbers issued for mines active or opened since 1971. The data also includes violation information.

Date of Government Version: 05/01/2020
Date Data Arrived at EDR: 05/21/2020
Date Made Active in Reports: 08/13/2020
Number of Days to Update: 84

Source: Department of Labor, Mine Safety and Health Administration
Telephone: 303-231-5959
Last EDR Contact: 08/25/2020
Next Scheduled EDR Contact: 12/07/2020
Data Release Frequency: Semi-Annually

MINES VIOLATIONS: MSHA Violation Assessment Data

Mines violation and assessment information. Department of Labor, Mine Safety & Health Administration.

GOVERNMENT RECORDS SEARCHED / DATA CURRENCY TRACKING

Date of Government Version: 05/28/2020
Date Data Arrived at EDR: 05/28/2020
Date Made Active in Reports: 08/13/2020
Number of Days to Update: 77

Source: DOL, Mine Safety & Health Admi
Telephone: 202-693-9424
Last EDR Contact: 08/26/2020
Next Scheduled EDR Contact: 12/14/2020
Data Release Frequency: Quarterly

US MINES 2: Ferrous and Nonferrous Metal Mines Database Listing

This map layer includes ferrous (ferrous metal mines are facilities that extract ferrous metals, such as iron ore or molybdenum) and nonferrous (Nonferrous metal mines are facilities that extract nonferrous metals, such as gold, silver, copper, zinc, and lead) metal mines in the United States.

Date of Government Version: 05/06/2020
Date Data Arrived at EDR: 05/27/2020
Date Made Active in Reports: 08/13/2020
Number of Days to Update: 78

Source: USGS
Telephone: 703-648-7709
Last EDR Contact: 05/27/2020
Next Scheduled EDR Contact: 09/07/2020
Data Release Frequency: Varies

US MINES 3: Active Mines & Mineral Plants Database Listing

Active Mines and Mineral Processing Plant operations for commodities monitored by the Minerals Information Team of the USGS.

Date of Government Version: 04/14/2011
Date Data Arrived at EDR: 06/08/2011
Date Made Active in Reports: 09/13/2011
Number of Days to Update: 97

Source: USGS
Telephone: 703-648-7709
Last EDR Contact: 05/21/2020
Next Scheduled EDR Contact: 09/07/2020
Data Release Frequency: Varies

ABANDONED MINES: Abandoned Mines

An inventory of land and water impacted by past mining (primarily coal mining) is maintained by OSMRE to provide information needed to implement the Surface Mining Control and Reclamation Act of 1977 (SMCRA). The inventory contains information on the location, type, and extent of AML impacts, as well as, information on the cost associated with the reclamation of those problems. The inventory is based upon field surveys by State, Tribal, and OSMRE program officials. It is dynamic to the extent that it is modified as new problems are identified and existing problems are reclaimed.

Date of Government Version: 03/05/2020
Date Data Arrived at EDR: 03/06/2020
Date Made Active in Reports: 05/29/2020
Number of Days to Update: 84

Source: Department of Interior
Telephone: 202-208-2609
Last EDR Contact: 06/19/2020
Next Scheduled EDR Contact: 09/21/2020
Data Release Frequency: Quarterly

FINDS: Facility Index System/Facility Registry System

Facility Index System. FINDS contains both facility information and 'pointers' to other sources that contain more detail. EDR includes the following FINDS databases in this report: PCS (Permit Compliance System), AIRS (Aerometric Information Retrieval System), DOCKET (Enforcement Docket used to manage and track information on civil judicial enforcement cases for all environmental statutes), FURS (Federal Underground Injection Control), C-DOCKET (Criminal Docket System used to track criminal enforcement actions for all environmental statutes), FFIS (Federal Facilities Information System), STATE (State Environmental Laws and Statutes), and PADS (PCB Activity Data System).

Date of Government Version: 02/03/2020
Date Data Arrived at EDR: 03/03/2020
Date Made Active in Reports: 05/28/2020
Number of Days to Update: 86

Source: EPA
Telephone: (415) 947-8000
Last EDR Contact: 08/26/2020
Next Scheduled EDR Contact: 12/14/2020
Data Release Frequency: Quarterly

UXO: Unexploded Ordnance Sites

A listing of unexploded ordnance site locations

Date of Government Version: 12/31/2017
Date Data Arrived at EDR: 01/17/2019
Date Made Active in Reports: 04/01/2019
Number of Days to Update: 74

Source: Department of Defense
Telephone: 703-704-1564
Last EDR Contact: 07/09/2020
Next Scheduled EDR Contact: 10/26/2020
Data Release Frequency: Varies

GOVERNMENT RECORDS SEARCHED / DATA CURRENCY TRACKING

ECHO: Enforcement & Compliance History Information

ECHO provides integrated compliance and enforcement information for about 800,000 regulated facilities nationwide.

Date of Government Version: 04/04/2020	Source: Environmental Protection Agency
Date Data Arrived at EDR: 04/07/2020	Telephone: 202-564-2280
Date Made Active in Reports: 06/26/2020	Last EDR Contact: 07/02/2020
Number of Days to Update: 80	Next Scheduled EDR Contact: 10/19/2020
	Data Release Frequency: Quarterly

DOCKET HWC: Hazardous Waste Compliance Docket Listing

A complete list of the Federal Agency Hazardous Waste Compliance Docket Facilities.

Date of Government Version: 05/31/2018	Source: Environmental Protection Agency
Date Data Arrived at EDR: 07/26/2018	Telephone: 202-564-0527
Date Made Active in Reports: 10/05/2018	Last EDR Contact: 08/19/2020
Number of Days to Update: 71	Next Scheduled EDR Contact: 12/07/2020
	Data Release Frequency: Varies

FUELS PROGRAM: EPA Fuels Program Registered Listing

This listing includes facilities that are registered under the Part 80 (Code of Federal Regulations) EPA Fuels Programs. All companies now are required to submit new and updated registrations.

Date of Government Version: 05/18/2020	Source: EPA
Date Data Arrived at EDR: 05/19/2020	Telephone: 800-385-6164
Date Made Active in Reports: 08/03/2020	Last EDR Contact: 08/17/2020
Number of Days to Update: 76	Next Scheduled EDR Contact: 11/30/2020
	Data Release Frequency: Quarterly

CA BOND EXP. PLAN: Bond Expenditure Plan

Department of Health Services developed a site-specific expenditure plan as the basis for an appropriation of Hazardous Substance Cleanup Bond Act funds. It is not updated.

Date of Government Version: 01/01/1989	Source: Department of Health Services
Date Data Arrived at EDR: 07/27/1994	Telephone: 916-255-2118
Date Made Active in Reports: 08/02/1994	Last EDR Contact: 05/31/1994
Number of Days to Update: 6	Next Scheduled EDR Contact: N/A
	Data Release Frequency: No Update Planned

CORTESE: "Cortese" Hazardous Waste & Substances Sites List

The sites for the list are designated by the State Water Resource Control Board (LUST), the Integrated Waste Board (SWF/LS), and the Department of Toxic Substances Control (Cal-Sites).

Date of Government Version: 03/23/2020	Source: CAL EPA/Office of Emergency Information
Date Data Arrived at EDR: 03/24/2020	Telephone: 916-323-3400
Date Made Active in Reports: 06/05/2020	Last EDR Contact: 06/22/2020
Number of Days to Update: 73	Next Scheduled EDR Contact: 10/05/2020
	Data Release Frequency: Quarterly

CUPA LIVERMORE-PLEASANTON: CUPA Facility Listing

list of facilities associated with the various CUPA programs in Livermore-Pleasanton

Date of Government Version: 05/01/2019	Source: Livermore-Pleasanton Fire Department
Date Data Arrived at EDR: 05/14/2019	Telephone: 925-454-2361
Date Made Active in Reports: 07/17/2019	Last EDR Contact: 08/14/2020
Number of Days to Update: 64	Next Scheduled EDR Contact: 11/23/2020
	Data Release Frequency: Varies

CUPA SAN FRANCISCO CO: CUPA Facility Listing

Cupa facilities

GOVERNMENT RECORDS SEARCHED / DATA CURRENCY TRACKING

Date of Government Version: 05/04/2020
Date Data Arrived at EDR: 05/06/2020
Date Made Active in Reports: 07/17/2020
Number of Days to Update: 72

Source: San Francisco County Department of Environmental Health
Telephone: 415-252-3896
Last EDR Contact: 07/28/2020
Next Scheduled EDR Contact: 11/16/2020
Data Release Frequency: Varies

KERN CO CUPA: Hazardous Material Business Plan

A listing of sites included in the Kern County Hazardous Material Business Plan.

Date of Government Version: 04/29/2020
Date Data Arrived at EDR: 05/05/2020
Date Made Active in Reports: 08/26/2020
Number of Days to Update: 113

Source: Kern County Public Health
Telephone: 661-321-3000
Last EDR Contact: 07/28/2020
Next Scheduled EDR Contact: 11/16/2020
Data Release Frequency: Varies

DRYCLEANERS: Cleaner Facilities

A list of drycleaner related facilities that have EPA ID numbers. These are facilities with certain SIC codes: power laundries, family and commercial; garment pressing and cleaner's agents; linen supply; coin-operated laundries and cleaning; drycleaning plants, except rugs; carpet and upholster cleaning; industrial launderers; laundry and garment services.

Date of Government Version: 06/04/2020
Date Data Arrived at EDR: 06/05/2020
Date Made Active in Reports: 08/17/2020
Number of Days to Update: 73

Source: Department of Toxic Substance Control
Telephone: 916-327-4498
Last EDR Contact: 08/24/2020
Next Scheduled EDR Contact: 12/13/2020
Data Release Frequency: Annually

DRYCLEAN AVAQMD: Antelope Valley Air Quality Management District Drycleaner Listing

A listing of dry cleaners in the Antelope Valley Air Quality Management District.

Date of Government Version: 05/28/2020
Date Data Arrived at EDR: 05/29/2020
Date Made Active in Reports: 08/12/2020
Number of Days to Update: 75

Source: Antelope Valley Air Quality Management District
Telephone: 661-723-8070
Last EDR Contact: 08/25/2020
Next Scheduled EDR Contact: 12/14/2020
Data Release Frequency: Varies

DRYCLEAN SOUTH COAST: South Coast Air Quality Management District Drycleaner Listing

A listing of dry cleaners in the South Coast Air Quality Management District

Date of Government Version: 03/25/2020
Date Data Arrived at EDR: 03/26/2020
Date Made Active in Reports: 06/15/2020
Number of Days to Update: 81

Source: South Coast Air Quality Management District
Telephone: 909-396-3211
Last EDR Contact: 08/17/2020
Next Scheduled EDR Contact: 12/07/2020
Data Release Frequency: Varies

EMI: Emissions Inventory Data

Toxics and criteria pollutant emissions data collected by the ARB and local air pollution agencies.

Date of Government Version: 12/31/2017
Date Data Arrived at EDR: 06/24/2019
Date Made Active in Reports: 08/22/2019
Number of Days to Update: 59

Source: California Air Resources Board
Telephone: 916-322-2990
Last EDR Contact: 06/16/2020
Next Scheduled EDR Contact: 09/28/2020
Data Release Frequency: Varies

ENF: Enforcement Action Listing

A listing of Water Board Enforcement Actions. Formal is everything except Oral/Verbal Communication, Notice of Violation, Expedited Payment Letter, and Staff Enforcement Letter.

Date of Government Version: 04/03/2020
Date Data Arrived at EDR: 04/07/2020
Date Made Active in Reports: 04/15/2020
Number of Days to Update: 8

Source: State Water Resources Control Board
Telephone: 916-445-9379
Last EDR Contact: 07/21/2020
Next Scheduled EDR Contact: 11/02/2020
Data Release Frequency: Varies

GOVERNMENT RECORDS SEARCHED / DATA CURRENCY TRACKING

Financial Assurance 1: Financial Assurance Information Listing Financial Assurance information

Date of Government Version: 04/09/2020	Source: Department of Toxic Substances Control
Date Data Arrived at EDR: 04/10/2020	Telephone: 916-255-3628
Date Made Active in Reports: 07/01/2020	Last EDR Contact: 07/14/2020
Number of Days to Update: 82	Next Scheduled EDR Contact: 11/02/2020
	Data Release Frequency: Varies

Financial Assurance 2: Financial Assurance Information Listing

A listing of financial assurance information for solid waste facilities. Financial assurance is intended to ensure that resources are available to pay for the cost of closure, post-closure care, and corrective measures if the owner or operator of a regulated facility is unable or unwilling to pay.

Date of Government Version: 05/14/2020	Source: California Integrated Waste Management Board
Date Data Arrived at EDR: 05/15/2020	Telephone: 916-341-6066
Date Made Active in Reports: 07/27/2020	Last EDR Contact: 08/04/2020
Number of Days to Update: 73	Next Scheduled EDR Contact: 11/23/2020
	Data Release Frequency: Varies

HAZNET: Facility and Manifest Data

Facility and Manifest Data. The data is extracted from the copies of hazardous waste manifests received each year by the DTSC. The annual volume of manifests is typically 700,000 - 1,000,000 annually, representing approximately 350,000 - 500,000 shipments. Data are from the manifests submitted without correction, and therefore many contain some invalid values for data elements such as generator ID, TSD ID, waste category, and disposal method. This database begins with calendar year 1993.

Date of Government Version: 12/31/2019	Source: California Environmental Protection Agency
Date Data Arrived at EDR: 04/15/2020	Telephone: 916-255-1136
Date Made Active in Reports: 07/02/2020	Last EDR Contact: 07/06/2020
Number of Days to Update: 78	Next Scheduled EDR Contact: 10/19/2020
	Data Release Frequency: Annually

ICE: ICE

Contains data pertaining to the Permitted Facilities with Inspections / Enforcements sites tracked in Envirostor.

Date of Government Version: 05/18/2020	Source: Department of Toxic Substances Control
Date Data Arrived at EDR: 05/19/2020	Telephone: 877-786-9427
Date Made Active in Reports: 07/31/2020	Last EDR Contact: 08/17/2020
Number of Days to Update: 73	Next Scheduled EDR Contact: 11/30/2020
	Data Release Frequency: Quarterly

HIST CORTESE: Hazardous Waste & Substance Site List

The sites for the list are designated by the State Water Resource Control Board [LUST], the Integrated Waste Board [SWF/LS], and the Department of Toxic Substances Control [CALSTES]. This listing is no longer updated by the state agency.

Date of Government Version: 04/01/2001	Source: Department of Toxic Substances Control
Date Data Arrived at EDR: 01/22/2009	Telephone: 916-323-3400
Date Made Active in Reports: 04/08/2009	Last EDR Contact: 01/22/2009
Number of Days to Update: 76	Next Scheduled EDR Contact: N/A
	Data Release Frequency: No Update Planned

HWP: EnviroStor Permitted Facilities Listing

Detailed information on permitted hazardous waste facilities and corrective action ("cleanups") tracked in EnviroStor.

Date of Government Version: 05/18/2020	Source: Department of Toxic Substances Control
Date Data Arrived at EDR: 05/18/2020	Telephone: 916-323-3400
Date Made Active in Reports: 07/31/2020	Last EDR Contact: 08/17/2020
Number of Days to Update: 74	Next Scheduled EDR Contact: 11/30/2020
	Data Release Frequency: Quarterly

GOVERNMENT RECORDS SEARCHED / DATA CURRENCY TRACKING

HWT: Registered Hazardous Waste Transporter Database

A listing of hazardous waste transporters. In California, unless specifically exempted, it is unlawful for any person to transport hazardous wastes unless the person holds a valid registration issued by DTSC. A hazardous waste transporter registration is valid for one year and is assigned a unique registration number.

Date of Government Version: 04/06/2020	Source: Department of Toxic Substances Control
Date Data Arrived at EDR: 04/08/2020	Telephone: 916-440-7145
Date Made Active in Reports: 06/26/2020	Last EDR Contact: 07/07/2020
Number of Days to Update: 79	Next Scheduled EDR Contact: 10/19/2020
	Data Release Frequency: Quarterly

MINES: Mines Site Location Listing

A listing of mine site locations from the Office of Mine Reclamation.

Date of Government Version: 06/08/2020	Source: Department of Conservation
Date Data Arrived at EDR: 06/09/2020	Telephone: 916-322-1080
Date Made Active in Reports: 08/19/2020	Last EDR Contact: 06/09/2020
Number of Days to Update: 71	Next Scheduled EDR Contact: 09/21/2020
	Data Release Frequency: Quarterly

MWMP: Medical Waste Management Program Listing

The Medical Waste Management Program (MWMP) ensures the proper handling and disposal of medical waste by permitting and inspecting medical waste Offsite Treatment Facilities (PDF) and Transfer Stations (PDF) throughout the state. MWMP also oversees all Medical Waste Transporters.

Date of Government Version: 05/28/2020	Source: Department of Public Health
Date Data Arrived at EDR: 06/02/2020	Telephone: 916-558-1784
Date Made Active in Reports: 08/14/2020	Last EDR Contact: 06/02/2020
Number of Days to Update: 73	Next Scheduled EDR Contact: 09/14/2020
	Data Release Frequency: Varies

NPDES: NPDES Permits Listing

A listing of NPDES permits, including stormwater.

Date of Government Version: 05/12/2020	Source: State Water Resources Control Board
Date Data Arrived at EDR: 05/12/2020	Telephone: 916-445-9379
Date Made Active in Reports: 07/28/2020	Last EDR Contact: 08/10/2020
Number of Days to Update: 77	Next Scheduled EDR Contact: 11/23/2020
	Data Release Frequency: Quarterly

PEST LIC: Pesticide Regulation Licenses Listing

A listing of licenses and certificates issued by the Department of Pesticide Regulation. The DPR issues licenses and/or certificates to: Persons and businesses that apply or sell pesticides; Pest control dealers and brokers; Persons who advise on agricultural pesticide applications.

Date of Government Version: 06/01/2020	Source: Department of Pesticide Regulation
Date Data Arrived at EDR: 06/02/2020	Telephone: 916-445-4038
Date Made Active in Reports: 08/14/2020	Last EDR Contact: 06/02/2020
Number of Days to Update: 73	Next Scheduled EDR Contact: 09/14/2020
	Data Release Frequency: Quarterly

PROC: Certified Processors Database

A listing of certified processors.

Date of Government Version: 06/08/2020	Source: Department of Conservation
Date Data Arrived at EDR: 06/09/2020	Telephone: 916-323-3836
Date Made Active in Reports: 08/19/2020	Last EDR Contact: 06/09/2020
Number of Days to Update: 71	Next Scheduled EDR Contact: 09/21/2020
	Data Release Frequency: Quarterly

GOVERNMENT RECORDS SEARCHED / DATA CURRENCY TRACKING

NOTIFY 65: Proposition 65 Records

Listings of all Proposition 65 incidents reported to counties by the State Water Resources Control Board and the Regional Water Quality Control Board. This database is no longer updated by the reporting agency.

Date of Government Version: 03/12/2020	Source: State Water Resources Control Board
Date Data Arrived at EDR: 03/13/2020	Telephone: 916-445-3846
Date Made Active in Reports: 05/21/2020	Last EDR Contact: 08/20/2020
Number of Days to Update: 69	Next Scheduled EDR Contact: 09/28/2020
	Data Release Frequency: No Update Planned

UIC: UIC Listing

A listing of wells identified as underground injection wells, in the California Oil and Gas Wells database.

Date of Government Version: 06/06/2020	Source: Department of Conservation
Date Data Arrived at EDR: 06/09/2020	Telephone: 916-445-2408
Date Made Active in Reports: 08/20/2020	Last EDR Contact: 06/09/2020
Number of Days to Update: 72	Next Scheduled EDR Contact: 09/21/2020
	Data Release Frequency: Varies

UIC GEO: Underground Injection Control Sites (GEOTRACKER)

Underground control injection sites

Date of Government Version: 06/08/2020	Source: State Water Resource Control Board
Date Data Arrived at EDR: 06/09/2020	Telephone: 866-480-1028
Date Made Active in Reports: 08/19/2020	Last EDR Contact: 06/09/2020
Number of Days to Update: 71	Next Scheduled EDR Contact: 09/21/2020
	Data Release Frequency: Varies

WASTEWATER PITS: Oil Wastewater Pits Listing

Water officials discovered that oil producers have been dumping chemical-laden wastewater into hundreds of unlined pits that are operating without proper permits. Inspections completed by the Central Valley Regional Water Quality Control Board revealed the existence of previously unidentified waste sites. The water boards review found that more than one-third of the region's active disposal pits are operating without permission.

Date of Government Version: 11/19/2019	Source: RWQCB, Central Valley Region
Date Data Arrived at EDR: 01/07/2020	Telephone: 559-445-5577
Date Made Active in Reports: 03/09/2020	Last EDR Contact: 07/09/2020
Number of Days to Update: 62	Next Scheduled EDR Contact: 10/19/2020
	Data Release Frequency: Varies

WDS: Waste Discharge System

Sites which have been issued waste discharge requirements.

Date of Government Version: 06/19/2007	Source: State Water Resources Control Board
Date Data Arrived at EDR: 06/20/2007	Telephone: 916-341-5227
Date Made Active in Reports: 06/29/2007	Last EDR Contact: 08/11/2020
Number of Days to Update: 9	Next Scheduled EDR Contact: 11/30/2020
	Data Release Frequency: No Update Planned

WIP: Well Investigation Program Case List

Well Investigation Program case in the San Gabriel and San Fernando Valley area.

Date of Government Version: 07/03/2009	Source: Los Angeles Water Quality Control Board
Date Data Arrived at EDR: 07/21/2009	Telephone: 213-576-6726
Date Made Active in Reports: 08/03/2009	Last EDR Contact: 06/17/2020
Number of Days to Update: 13	Next Scheduled EDR Contact: 10/05/2020
	Data Release Frequency: No Update Planned

MILITARY PRIV SITES: Military Privatized Sites (GEOTRACKER)

Military privatized sites

GOVERNMENT RECORDS SEARCHED / DATA CURRENCY TRACKING

Date of Government Version: 06/08/2020
Date Data Arrived at EDR: 06/09/2020
Date Made Active in Reports: 08/19/2020
Number of Days to Update: 71

Source: State Water Resources Control Board
Telephone: 866-480-1028
Last EDR Contact: 06/09/2020
Next Scheduled EDR Contact: 09/21/2020
Data Release Frequency: Varies

PROJECT: Project Sites (GEOTRACKER) Projects sites

Date of Government Version: 06/08/2020
Date Data Arrived at EDR: 06/09/2020
Date Made Active in Reports: 08/19/2020
Number of Days to Update: 71

Source: State Water Resources Control Board
Telephone: 866-480-1028
Last EDR Contact: 06/09/2020
Next Scheduled EDR Contact: 09/21/2020
Data Release Frequency: Varies

WDR: Waste Discharge Requirements Listing

In general, the Waste Discharge Requirements (WDRs) Program (sometimes also referred to as the "Non Chapter 15 (Non 15) Program") regulates point discharges that are exempt pursuant to Subsection 20090 of Title 27 and not subject to the Federal Water Pollution Control Act. Exemptions from Title 27 may be granted for nine categories of discharges (e.g., sewage, wastewater, etc.) that meet, and continue to meet, the preconditions listed for each specific exemption. The scope of the WDRs Program also includes the discharge of wastes classified as inert, pursuant to section 20230 of Title 27.

Date of Government Version: 06/08/2020
Date Data Arrived at EDR: 06/09/2020
Date Made Active in Reports: 08/20/2020
Number of Days to Update: 72

Source: State Water Resources Control Board
Telephone: 916-341-5810
Last EDR Contact: 06/09/2020
Next Scheduled EDR Contact: 09/21/2020
Data Release Frequency: Quarterly

CIWQS: California Integrated Water Quality System

The California Integrated Water Quality System (CIWQS) is a computer system used by the State and Regional Water Quality Control Boards to track information about places of environmental interest, manage permits and other orders, track inspections, and manage violations and enforcement activities.

Date of Government Version: 06/01/2020
Date Data Arrived at EDR: 06/02/2020
Date Made Active in Reports: 08/14/2020
Number of Days to Update: 73

Source: State Water Resources Control Board
Telephone: 866-794-4977
Last EDR Contact: 06/02/2020
Next Scheduled EDR Contact: 09/14/2020
Data Release Frequency: Varies

CERS: CalEPA Regulated Site Portal Data

The CalEPA Regulated Site Portal database combines data about environmentally regulated sites and facilities in California into a single database. It combines data from a variety of state and federal databases, and provides an overview of regulated activities across the spectrum of environmental programs for any given location in California. These activities include hazardous materials and waste, state and federal cleanups, impacted ground and surface waters, and toxic materials

Date of Government Version: 04/20/2020
Date Data Arrived at EDR: 04/21/2020
Date Made Active in Reports: 07/13/2020
Number of Days to Update: 83

Source: California Environmental Protection Agency
Telephone: 916-323-2514
Last EDR Contact: 07/21/2020
Next Scheduled EDR Contact: 11/02/2020
Data Release Frequency: Varies

NON-CASE INFO: Non-Case Information Sites (GEOTRACKER)

Non-Case Information sites

Date of Government Version: 06/08/2020
Date Data Arrived at EDR: 06/09/2020
Date Made Active in Reports: 08/19/2020
Number of Days to Update: 71

Source: State Water Resources Control Board
Telephone: 866-480-1028
Last EDR Contact: 06/09/2020
Next Scheduled EDR Contact: 09/21/2020
Data Release Frequency: Varies

GOVERNMENT RECORDS SEARCHED / DATA CURRENCY TRACKING

OTHER OIL GAS: Other Oil & Gas Projects Sites (GEOTRACKER)

Other Oil & Gas Projects sites

Date of Government Version: 06/08/2020
Date Data Arrived at EDR: 06/09/2020
Date Made Active in Reports: 08/19/2020
Number of Days to Update: 71

Source: State Water Resources Control Board
Telephone: 866-480-1028
Last EDR Contact: 06/09/2020
Next Scheduled EDR Contact: 09/21/2020
Data Release Frequency: Varies

PROD WATER PONDS: Produced Water Ponds Sites (GEOTRACKER)

Produced water ponds sites

Date of Government Version: 06/08/2020
Date Data Arrived at EDR: 06/09/2020
Date Made Active in Reports: 08/19/2020
Number of Days to Update: 71

Source: State Water Resources Control Board
Telephone: 866-480-1028
Last EDR Contact: 06/09/2020
Next Scheduled EDR Contact: 09/21/2020
Data Release Frequency: Varies

SAMPLING POINT: Sampling Point ? Public Sites (GEOTRACKER)

Sampling point - public sites

Date of Government Version: 06/08/2020
Date Data Arrived at EDR: 06/09/2020
Date Made Active in Reports: 08/19/2020
Number of Days to Update: 71

Source: State Water Resources Control Board
Telephone: 866-480-1028
Last EDR Contact: 06/09/2020
Next Scheduled EDR Contact: 09/21/2020
Data Release Frequency: Varies

WELL STIM PROJ: Well Stimulation Project (GEOTRACKER)

Includes areas of groundwater monitoring plans, a depiction of the monitoring network, and the facilities, boundaries, and subsurface characteristics of the oilfield and the features (oil and gas wells, produced water ponds, UIC wells, water supply wells, etc?) being monitored

Date of Government Version: 06/08/2020
Date Data Arrived at EDR: 06/09/2020
Date Made Active in Reports: 08/19/2020
Number of Days to Update: 71

Source: State Water Resources Control Board
Telephone: 866-480-1028
Last EDR Contact: 06/09/2020
Next Scheduled EDR Contact: 09/21/2020
Data Release Frequency: Varies

PCS: Permit Compliance System

PCS is a computerized management information system that contains data on National Pollutant Discharge Elimination System (NPDES) permit holding facilities. PCS tracks the permit, compliance, and enforcement status of NPDES facilities.

Date of Government Version: 07/14/2011
Date Data Arrived at EDR: 08/05/2011
Date Made Active in Reports: 09/29/2011
Number of Days to Update: 55

Source: EPA, Office of Water
Telephone: 202-564-2496
Last EDR Contact: 06/08/2020
Next Scheduled EDR Contact: 09/21/2020
Data Release Frequency: Semi-Annually

PCS INACTIVE: Listing of Inactive PCS Permits

An inactive permit is a facility that has shut down or is no longer discharging.

Date of Government Version: 11/05/2014
Date Data Arrived at EDR: 01/06/2015
Date Made Active in Reports: 05/06/2015
Number of Days to Update: 120

Source: EPA
Telephone: 202-564-2496
Last EDR Contact: 07/09/2020
Next Scheduled EDR Contact: 10/19/2020
Data Release Frequency: Semi-Annually

PCS ENF: Enforcement data

No description is available for this data

GOVERNMENT RECORDS SEARCHED / DATA CURRENCY TRACKING

Date of Government Version: 12/31/2014
Date Data Arrived at EDR: 02/05/2015
Date Made Active in Reports: 03/06/2015
Number of Days to Update: 29

Source: EPA
Telephone: 202-564-2497
Last EDR Contact: 07/01/2020
Next Scheduled EDR Contact: 10/19/2020
Data Release Frequency: Varies

MINES MRDS: Mineral Resources Data System Mineral Resources Data System

Date of Government Version: 04/06/2018
Date Data Arrived at EDR: 10/21/2019
Date Made Active in Reports: 10/24/2019
Number of Days to Update: 3

Source: USGS
Telephone: 703-648-6533
Last EDR Contact: 05/21/2020
Next Scheduled EDR Contact: 09/07/2020
Data Release Frequency: Varies

HWTS: Hazardous Waste Tracking System

DTSC maintains the Hazardous Waste Tracking System that stores ID number information since the early 1980s and manifest data since 1993. The system collects both manifest copies from the generator and destination facility.

Date of Government Version: 04/08/2020
Date Data Arrived at EDR: 04/09/2020
Date Made Active in Reports: 07/01/2020
Number of Days to Update: 83

Source: Department of Toxic Substances Control
Telephone: 916-324-2444
Last EDR Contact: 08/02/2020
Next Scheduled EDR Contact: 10/18/2020
Data Release Frequency: Varies

EDR HIGH RISK HISTORICAL RECORDS

EDR Exclusive Records

EDR MGP: EDR Proprietary Manufactured Gas Plants

The EDR Proprietary Manufactured Gas Plant Database includes records of coal gas plants (manufactured gas plants) compiled by EDR's researchers. Manufactured gas sites were used in the United States from the 1800's to 1950's to produce a gas that could be distributed and used as fuel. These plants used whale oil, rosin, coal, or a mixture of coal, oil, and water that also produced a significant amount of waste. Many of the byproducts of the gas production, such as coal tar (oily waste containing volatile and non-volatile chemicals), sludges, oils and other compounds are potentially hazardous to human health and the environment. The byproduct from this process was frequently disposed of directly at the plant site and can remain or spread slowly, serving as a continuous source of soil and groundwater contamination.

Date of Government Version: N/A
Date Data Arrived at EDR: N/A
Date Made Active in Reports: N/A
Number of Days to Update: N/A

Source: EDR, Inc.
Telephone: N/A
Last EDR Contact: N/A
Next Scheduled EDR Contact: N/A
Data Release Frequency: No Update Planned

EDR Hist Auto: EDR Exclusive Historical Auto Stations

EDR has searched selected national collections of business directories and has collected listings of potential gas station/filling station/service station sites that were available to EDR researchers. EDR's review was limited to those categories of sources that might, in EDR's opinion, include gas station/filling station/service station establishments. The categories reviewed included, but were not limited to gas, gas station, gasoline station, filling station, auto, automobile repair, auto service station, service station, etc. This database falls within a category of information EDR classifies as "High Risk Historical Records", or HRHR. EDR's HRHR effort presents unique and sometimes proprietary data about past sites and operations that typically create environmental concerns, but may not show up in current government records searches.

Date of Government Version: N/A
Date Data Arrived at EDR: N/A
Date Made Active in Reports: N/A
Number of Days to Update: N/A

Source: EDR, Inc.
Telephone: N/A
Last EDR Contact: N/A
Next Scheduled EDR Contact: N/A
Data Release Frequency: Varies

GOVERNMENT RECORDS SEARCHED / DATA CURRENCY TRACKING

EDR Hist Cleaner: EDR Exclusive Historical Cleaners

EDR has searched selected national collections of business directories and has collected listings of potential dry cleaner sites that were available to EDR researchers. EDR's review was limited to those categories of sources that might, in EDR's opinion, include dry cleaning establishments. The categories reviewed included, but were not limited to dry cleaners, cleaners, laundry, laundromat, cleaning/laundry, wash & dry etc. This database falls within a category of information EDR classifies as "High Risk Historical Records", or HRHR. EDR's HRHR effort presents unique and sometimes proprietary data about past sites and operations that typically create environmental concerns, but may not show up in current government records searches.

Date of Government Version: N/A	Source: EDR, Inc.
Date Data Arrived at EDR: N/A	Telephone: N/A
Date Made Active in Reports: N/A	Last EDR Contact: N/A
Number of Days to Update: N/A	Next Scheduled EDR Contact: N/A
	Data Release Frequency: Varies

EDR RECOVERED GOVERNMENT ARCHIVES

Exclusive Recovered Govt. Archives

RGA LF: Recovered Government Archive Solid Waste Facilities List

The EDR Recovered Government Archive Landfill database provides a list of landfills derived from historical databases and includes many records that no longer appear in current government lists. Compiled from Records formerly available from the Department of Resources Recycling and Recovery in California.

Date of Government Version: N/A	Source: Department of Resources Recycling and Recovery
Date Data Arrived at EDR: 07/01/2013	Telephone: N/A
Date Made Active in Reports: 01/13/2014	Last EDR Contact: 06/01/2012
Number of Days to Update: 196	Next Scheduled EDR Contact: N/A
	Data Release Frequency: Varies

RGA LUST: Recovered Government Archive Leaking Underground Storage Tank

The EDR Recovered Government Archive Leaking Underground Storage Tank database provides a list of LUST incidents derived from historical databases and includes many records that no longer appear in current government lists. Compiled from Records formerly available from the State Water Resources Control Board in California.

Date of Government Version: N/A	Source: State Water Resources Control Board
Date Data Arrived at EDR: 07/01/2013	Telephone: N/A
Date Made Active in Reports: 12/30/2013	Last EDR Contact: 06/01/2012
Number of Days to Update: 182	Next Scheduled EDR Contact: N/A
	Data Release Frequency: Varies

COUNTY RECORDS

ALAMEDA COUNTY:

CS ALAMEDA: Contaminated Sites

A listing of contaminated sites overseen by the Toxic Release Program (oil and groundwater contamination from chemical releases and spills) and the Leaking Underground Storage Tank Program (soil and ground water contamination from leaking petroleum USTs).

Date of Government Version: 01/09/2019	Source: Alameda County Environmental Health Services
Date Data Arrived at EDR: 01/11/2019	Telephone: 510-567-6700
Date Made Active in Reports: 03/05/2019	Last EDR Contact: 06/30/2020
Number of Days to Update: 53	Next Scheduled EDR Contact: 10/19/2020
	Data Release Frequency: Semi-Annually

UST ALAMEDA: Underground Tanks

Underground storage tank sites located in Alameda county.

Date of Government Version: 06/30/2020	Source: Alameda County Environmental Health Services
Date Data Arrived at EDR: 07/01/2020	Telephone: 510-567-6700
Date Made Active in Reports: 07/17/2020	Last EDR Contact: 06/30/2020
Number of Days to Update: 16	Next Scheduled EDR Contact: 10/19/2020
	Data Release Frequency: Semi-Annually

AMADOR COUNTY:

GOVERNMENT RECORDS SEARCHED / DATA CURRENCY TRACKING

CUPA AMADOR: CUPA Facility List Cupa Facility List

Date of Government Version: 05/18/2020
Date Data Arrived at EDR: 05/19/2020
Date Made Active in Reports: 06/01/2020
Number of Days to Update: 13

Source: Amador County Environmental Health
Telephone: 209-223-6439
Last EDR Contact: 07/28/2020
Next Scheduled EDR Contact: 11/16/2020
Data Release Frequency: Varies

BUTTE COUNTY:

CUPA BUTTE: CUPA Facility Listing Cupa facility list.

Date of Government Version: 04/21/2017
Date Data Arrived at EDR: 04/25/2017
Date Made Active in Reports: 08/09/2017
Number of Days to Update: 106

Source: Public Health Department
Telephone: 530-538-7149
Last EDR Contact: 06/30/2020
Next Scheduled EDR Contact: 10/19/2020
Data Release Frequency: No Update Planned

CALVERAS COUNTY:

CUPA CALVERAS: CUPA Facility Listing Cupa Facility Listing

Date of Government Version: 03/27/2020
Date Data Arrived at EDR: 03/31/2020
Date Made Active in Reports: 06/15/2020
Number of Days to Update: 76

Source: Calveras County Environmental Health
Telephone: 209-754-6399
Last EDR Contact: 06/17/2020
Next Scheduled EDR Contact: 10/05/2020
Data Release Frequency: Quarterly

COLUSA COUNTY:

CUPA COLUSA: CUPA Facility List Cupa facility list.

Date of Government Version: 04/06/2020
Date Data Arrived at EDR: 04/23/2020
Date Made Active in Reports: 07/10/2020
Number of Days to Update: 78

Source: Health & Human Services
Telephone: 530-458-0396
Last EDR Contact: 07/28/2020
Next Scheduled EDR Contact: 11/16/2020
Data Release Frequency: Semi-Annually

CONTRA COSTA COUNTY:

SL CONTRA COSTA: Site List

List includes sites from the underground tank, hazardous waste generator and business plan/2185 programs.

Date of Government Version: 04/01/2020
Date Data Arrived at EDR: 04/20/2020
Date Made Active in Reports: 07/06/2020
Number of Days to Update: 77

Source: Contra Costa Health Services Department
Telephone: 925-646-2286
Last EDR Contact: 07/21/2020
Next Scheduled EDR Contact: 11/09/2020
Data Release Frequency: Semi-Annually

DEL NORTE COUNTY:

GOVERNMENT RECORDS SEARCHED / DATA CURRENCY TRACKING

CUPA DEL NORTE: CUPA Facility List Cupa Facility list

Date of Government Version: 04/16/2020
Date Data Arrived at EDR: 04/20/2020
Date Made Active in Reports: 07/08/2020
Number of Days to Update: 79

Source: Del Norte County Environmental Health Division
Telephone: 707-465-0426
Last EDR Contact: 08/13/2020
Next Scheduled EDR Contact: 11/09/2020
Data Release Frequency: Varies

EL DORADO COUNTY:

CUPA EL DORADO: CUPA Facility List CUPA facility list.

Date of Government Version: 05/07/2020
Date Data Arrived at EDR: 05/07/2020
Date Made Active in Reports: 07/23/2020
Number of Days to Update: 77

Source: El Dorado County Environmental Management Department
Telephone: 530-621-6623
Last EDR Contact: 08/13/2020
Next Scheduled EDR Contact: 11/09/2020
Data Release Frequency: Varies

FRESNO COUNTY:

CUPA FRESNO: CUPA Resources List

Certified Unified Program Agency. CUPA's are responsible for implementing a unified hazardous materials and hazardous waste management regulatory program. The agency provides oversight of businesses that deal with hazardous materials, operate underground storage tanks or aboveground storage tanks.

Date of Government Version: 01/10/2020
Date Data Arrived at EDR: 03/31/2020
Date Made Active in Reports: 06/15/2020
Number of Days to Update: 76

Source: Dept. of Community Health
Telephone: 559-445-3271
Last EDR Contact: 06/30/2020
Next Scheduled EDR Contact: 10/12/2020
Data Release Frequency: Semi-Annually

GLENN COUNTY:

CUPA GLENN: CUPA Facility List Cupa facility list

Date of Government Version: 01/22/2018
Date Data Arrived at EDR: 01/24/2018
Date Made Active in Reports: 03/14/2018
Number of Days to Update: 49

Source: Glenn County Air Pollution Control District
Telephone: 830-934-6500
Last EDR Contact: 07/14/2020
Next Scheduled EDR Contact: 11/02/2020
Data Release Frequency: No Update Planned

HUMBOLDT COUNTY:

CUPA HUMBOLDT: CUPA Facility List CUPA facility list.

Date of Government Version: 05/19/2020
Date Data Arrived at EDR: 05/20/2020
Date Made Active in Reports: 06/15/2020
Number of Days to Update: 26

Source: Humboldt County Environmental Health
Telephone: N/A
Last EDR Contact: 08/11/2020
Next Scheduled EDR Contact: 11/30/2020
Data Release Frequency: Semi-Annually

IMPERIAL COUNTY:

GOVERNMENT RECORDS SEARCHED / DATA CURRENCY TRACKING

CUPA IMPERIAL: CUPA Facility List Cupa facility list.

Date of Government Version: 04/09/2020
Date Data Arrived at EDR: 04/10/2020
Date Made Active in Reports: 07/01/2020
Number of Days to Update: 82

Source: San Diego Border Field Office
Telephone: 760-339-2777
Last EDR Contact: 07/14/2020
Next Scheduled EDR Contact: 11/02/2020
Data Release Frequency: Varies

INYO COUNTY:

CUPA INYO: CUPA Facility List Cupa facility list.

Date of Government Version: 04/02/2018
Date Data Arrived at EDR: 04/03/2018
Date Made Active in Reports: 06/14/2018
Number of Days to Update: 73

Source: Inyo County Environmental Health Services
Telephone: 760-878-0238
Last EDR Contact: 08/11/2020
Next Scheduled EDR Contact: 11/30/2020
Data Release Frequency: Varies

KERN COUNTY:

UST KERN: Underground Storage Tank Sites & Tank Listing Kern County Sites and Tanks Listing.

Date of Government Version: 04/29/2020
Date Data Arrived at EDR: 05/05/2020
Date Made Active in Reports: 07/17/2020
Number of Days to Update: 73

Source: Kern County Environment Health Services Department
Telephone: 661-862-8700
Last EDR Contact: 07/28/2020
Next Scheduled EDR Contact: 11/16/2020
Data Release Frequency: Quarterly

KINGS COUNTY:

CUPA KINGS: CUPA Facility List

A listing of sites included in the county's Certified Unified Program Agency database. California's Secretary for Environmental Protection established the unified hazardous materials and hazardous waste regulatory program as required by chapter 6.11 of the California Health and Safety Code. The Unified Program consolidates the administration, permits, inspections, and enforcement activities.

Date of Government Version: 05/11/2020
Date Data Arrived at EDR: 05/12/2020
Date Made Active in Reports: 07/27/2020
Number of Days to Update: 76

Source: Kings County Department of Public Health
Telephone: 559-584-1411
Last EDR Contact: 08/21/2020
Next Scheduled EDR Contact: 11/30/2020
Data Release Frequency: Varies

LAKE COUNTY:

CUPA LAKE: CUPA Facility List Cupa facility list

Date of Government Version: 04/20/2020
Date Data Arrived at EDR: 04/28/2020
Date Made Active in Reports: 07/14/2020
Number of Days to Update: 77

Source: Lake County Environmental Health
Telephone: 707-263-1164
Last EDR Contact: 07/08/2020
Next Scheduled EDR Contact: 10/26/2020
Data Release Frequency: Varies

LASSEN COUNTY:

GOVERNMENT RECORDS SEARCHED / DATA CURRENCY TRACKING

CUPA LASSEN: CUPA Facility List Cupa facility list

Date of Government Version: 01/30/2020
Date Data Arrived at EDR: 01/31/2020
Date Made Active in Reports: 04/09/2020
Number of Days to Update: 69

Source: Lassen County Environmental Health
Telephone: 530-251-8528
Last EDR Contact: 08/11/2020
Next Scheduled EDR Contact: 11/02/2020
Data Release Frequency: Varies

LOS ANGELES COUNTY:

AOCONCERN: Key Areas of Concerns in Los Angeles County

San Gabriel Valley areas where VOC contamination is at or above the MCL as designated by region 9 EPA office. Date of Government Version: 3/30/2009 Exide Site area is a cleanup plan of lead-impacted soil surrounding the former Exide Facility as designated by the DTSC. Date of Government Version: 7/17/2017

Date of Government Version: 03/30/2009
Date Data Arrived at EDR: 03/31/2009
Date Made Active in Reports: 10/23/2009
Number of Days to Update: 206

Source: N/A
Telephone: N/A
Last EDR Contact: 06/10/2020
Next Scheduled EDR Contact: 09/28/2020
Data Release Frequency: No Update Planned

HMS LOS ANGELES: HMS: Street Number List

Industrial Waste and Underground Storage Tank Sites.

Date of Government Version: 03/26/2020
Date Data Arrived at EDR: 03/26/2020
Date Made Active in Reports: 06/15/2020
Number of Days to Update: 81

Source: Department of Public Works
Telephone: 626-458-3517
Last EDR Contact: 06/30/2020
Next Scheduled EDR Contact: 10/19/2020
Data Release Frequency: Semi-Annually

LF LOS ANGELES: List of Solid Waste Facilities

Solid Waste Facilities in Los Angeles County.

Date of Government Version: 04/13/2020
Date Data Arrived at EDR: 04/14/2020
Date Made Active in Reports: 07/01/2020
Number of Days to Update: 78

Source: La County Department of Public Works
Telephone: 818-458-5185
Last EDR Contact: 07/13/2020
Next Scheduled EDR Contact: 10/26/2020
Data Release Frequency: Varies

LF LOS ANGELES CITY: City of Los Angeles Landfills

Landfills owned and maintained by the City of Los Angeles.

Date of Government Version: 01/01/2019
Date Data Arrived at EDR: 01/15/2019
Date Made Active in Reports: 03/07/2019
Number of Days to Update: 51

Source: Engineering & Construction Division
Telephone: 213-473-7869
Last EDR Contact: 07/08/2020
Next Scheduled EDR Contact: 10/26/2020
Data Release Frequency: Varies

LOS ANGELES AST: Active & Inactive AST Inventory

A listing of active & inactive above ground petroleum storage tank site locations, located in the City of Los Angeles.

Date of Government Version: 06/01/2019
Date Data Arrived at EDR: 06/25/2019
Date Made Active in Reports: 08/22/2019
Number of Days to Update: 58

Source: Los Angeles Fire Department
Telephone: 213-978-3800
Last EDR Contact: 06/25/2020
Next Scheduled EDR Contact: 10/05/2020
Data Release Frequency: Varies

GOVERNMENT RECORDS SEARCHED / DATA CURRENCY TRACKING

LOS ANGELES CO LF METHANE: Methane Producing Landfills

This data was created on April 30, 2012 to represent known disposal sites in Los Angeles County that may produce and emanate methane gas. The shapefile contains disposal sites within Los Angeles County that once accepted degradable refuse material. Information used to create this data was extracted from a landfill survey performed by County Engineers (Major Waste System Map, 1973) as well as historical records from CalRecycle, Regional Water Quality Control Board, and Los Angeles County Department of Public Health

Date of Government Version: 04/30/2012	Source: Los Angeles County Department of Public Works
Date Data Arrived at EDR: 04/17/2019	Telephone: 626-458-6973
Date Made Active in Reports: 05/29/2019	Last EDR Contact: 08/11/2020
Number of Days to Update: 42	Next Scheduled EDR Contact: 10/26/2020
	Data Release Frequency: No Update Planned

LOS ANGELES HM: Active & Inactive Hazardous Materials Inventory

A listing of active & inactive hazardous materials facility locations, located in the City of Los Angeles.

Date of Government Version: 06/01/2019	Source: Los Angeles Fire Department
Date Data Arrived at EDR: 06/25/2019	Telephone: 213-978-3800
Date Made Active in Reports: 08/22/2019	Last EDR Contact: 06/25/2020
Number of Days to Update: 58	Next Scheduled EDR Contact: 10/05/2020
	Data Release Frequency: Varies

LOS ANGELES UST: Active & Inactive UST Inventory

A listing of active & inactive underground storage tank site locations and underground storage tank historical sites, located in the City of Los Angeles.

Date of Government Version: 06/01/2019	Source: Los Angeles Fire Department
Date Data Arrived at EDR: 06/25/2019	Telephone: 213-978-3800
Date Made Active in Reports: 08/22/2019	Last EDR Contact: 06/25/2020
Number of Days to Update: 58	Next Scheduled EDR Contact: 10/05/2020
	Data Release Frequency: Varies

SITE MIT LOS ANGELES: Site Mitigation List

Industrial sites that have had some sort of spill or complaint.

Date of Government Version: 03/25/2020	Source: Community Health Services
Date Data Arrived at EDR: 04/14/2020	Telephone: 323-890-7806
Date Made Active in Reports: 07/01/2020	Last EDR Contact: 07/17/2020
Number of Days to Update: 78	Next Scheduled EDR Contact: 10/26/2020
	Data Release Frequency: Annually

UST EL SEGUNDO: City of El Segundo Underground Storage Tank

Underground storage tank sites located in El Segundo city.

Date of Government Version: 01/21/2017	Source: City of El Segundo Fire Department
Date Data Arrived at EDR: 04/19/2017	Telephone: 310-524-2236
Date Made Active in Reports: 05/10/2017	Last EDR Contact: 07/08/2020
Number of Days to Update: 21	Next Scheduled EDR Contact: 10/26/2020
	Data Release Frequency: No Update Planned

UST LONG BEACH: City of Long Beach Underground Storage Tank

Underground storage tank sites located in the city of Long Beach.

Date of Government Version: 04/22/2019	Source: City of Long Beach Fire Department
Date Data Arrived at EDR: 04/23/2019	Telephone: 562-570-2563
Date Made Active in Reports: 06/27/2019	Last EDR Contact: 07/14/2020
Number of Days to Update: 65	Next Scheduled EDR Contact: 11/02/2020
	Data Release Frequency: Varies

GOVERNMENT RECORDS SEARCHED / DATA CURRENCY TRACKING

UST TORRANCE: City of Torrance Underground Storage Tank
Underground storage tank sites located in the city of Torrance.

Date of Government Version: 06/27/2019	Source: City of Torrance Fire Department
Date Data Arrived at EDR: 07/30/2019	Telephone: 310-618-2973
Date Made Active in Reports: 10/02/2019	Last EDR Contact: 07/14/2020
Number of Days to Update: 64	Next Scheduled EDR Contact: 11/02/2020
	Data Release Frequency: Semi-Annually

MADERA COUNTY:

CUPA MADERA: CUPA Facility List

A listing of sites included in the county's Certified Unified Program Agency database. California's Secretary for Environmental Protection established the unified hazardous materials and hazardous waste regulatory program as required by chapter 6.11 of the California Health and Safety Code. The Unified Program consolidates the administration, permits, inspections, and enforcement activities.

Date of Government Version: 02/24/2020	Source: Madera County Environmental Health
Date Data Arrived at EDR: 02/25/2020	Telephone: 559-675-7823
Date Made Active in Reports: 05/07/2020	Last EDR Contact: 08/04/2020
Number of Days to Update: 72	Next Scheduled EDR Contact: 11/30/2020
	Data Release Frequency: Varies

MARIN COUNTY:

UST MARIN: Underground Storage Tank Sites
Currently permitted USTs in Marin County.

Date of Government Version: 09/26/2018	Source: Public Works Department Waste Management
Date Data Arrived at EDR: 10/04/2018	Telephone: 415-473-6647
Date Made Active in Reports: 11/02/2018	Last EDR Contact: 06/24/2020
Number of Days to Update: 29	Next Scheduled EDR Contact: 10/12/2020
	Data Release Frequency: Semi-Annually

MERCED COUNTY:

CUPA MERCED: CUPA Facility List
CUPA facility list.

Date of Government Version: 07/28/2020	Source: Merced County Environmental Health
Date Data Arrived at EDR: 07/30/2020	Telephone: 209-381-1094
Date Made Active in Reports: 07/31/2020	Last EDR Contact: 07/24/2020
Number of Days to Update: 1	Next Scheduled EDR Contact: 11/30/2020
	Data Release Frequency: Varies

MONO COUNTY:

CUPA MONO: CUPA Facility List
CUPA Facility List

Date of Government Version: 05/15/2020	Source: Mono County Health Department
Date Data Arrived at EDR: 06/02/2020	Telephone: 760-932-5580
Date Made Active in Reports: 08/14/2020	Last EDR Contact: 08/19/2020
Number of Days to Update: 73	Next Scheduled EDR Contact: 12/07/2020
	Data Release Frequency: Varies

MONTEREY COUNTY:

GOVERNMENT RECORDS SEARCHED / DATA CURRENCY TRACKING

CUPA MONTEREY: CUPA Facility Listing

CUPA Program listing from the Environmental Health Division.

Date of Government Version: 07/13/2020
Date Data Arrived at EDR: 07/15/2020
Date Made Active in Reports: 07/31/2020
Number of Days to Update: 16

Source: Monterey County Health Department
Telephone: 831-796-1297
Last EDR Contact: 07/08/2020
Next Scheduled EDR Contact: 10/12/2020
Data Release Frequency: Varies

NAPA COUNTY:

LUST NAPA: Sites With Reported Contamination

A listing of leaking underground storage tank sites located in Napa county.

Date of Government Version: 01/09/2017
Date Data Arrived at EDR: 01/11/2017
Date Made Active in Reports: 03/02/2017
Number of Days to Update: 50

Source: Napa County Department of Environmental Management
Telephone: 707-253-4269
Last EDR Contact: 08/19/2020
Next Scheduled EDR Contact: 12/07/2020
Data Release Frequency: No Update Planned

UST NAPA: Closed and Operating Underground Storage Tank Sites

Underground storage tank sites located in Napa county.

Date of Government Version: 09/05/2019
Date Data Arrived at EDR: 09/09/2019
Date Made Active in Reports: 10/31/2019
Number of Days to Update: 52

Source: Napa County Department of Environmental Management
Telephone: 707-253-4269
Last EDR Contact: 08/19/2020
Next Scheduled EDR Contact: 12/07/2020
Data Release Frequency: No Update Planned

NEVADA COUNTY:

CUPA NEVADA: CUPA Facility List

CUPA facility list.

Date of Government Version: 05/06/2020
Date Data Arrived at EDR: 05/07/2020
Date Made Active in Reports: 07/24/2020
Number of Days to Update: 78

Source: Community Development Agency
Telephone: 530-265-1467
Last EDR Contact: 07/21/2020
Next Scheduled EDR Contact: 11/09/2020
Data Release Frequency: Varies

ORANGE COUNTY:

IND_SITE ORANGE: List of Industrial Site Cleanups

Petroleum and non-petroleum spills.

Date of Government Version: 05/01/2020
Date Data Arrived at EDR: 05/08/2020
Date Made Active in Reports: 07/24/2020
Number of Days to Update: 77

Source: Health Care Agency
Telephone: 714-834-3446
Last EDR Contact: 07/31/2020
Next Scheduled EDR Contact: 11/16/2020
Data Release Frequency: Annually

LUST ORANGE: List of Underground Storage Tank Cleanups

Orange County Underground Storage Tank Cleanups (LUST).

Date of Government Version: 05/01/2020
Date Data Arrived at EDR: 05/08/2020
Date Made Active in Reports: 07/24/2020
Number of Days to Update: 77

Source: Health Care Agency
Telephone: 714-834-3446
Last EDR Contact: 07/31/2020
Next Scheduled EDR Contact: 11/16/2020
Data Release Frequency: Quarterly

GOVERNMENT RECORDS SEARCHED / DATA CURRENCY TRACKING

UST ORANGE: List of Underground Storage Tank Facilities

Orange County Underground Storage Tank Facilities (UST).

Date of Government Version: 05/01/2020
Date Data Arrived at EDR: 05/05/2020
Date Made Active in Reports: 07/17/2020
Number of Days to Update: 73

Source: Health Care Agency
Telephone: 714-834-3446
Last EDR Contact: 08/03/2020
Next Scheduled EDR Contact: 11/16/2020
Data Release Frequency: Quarterly

PLACER COUNTY:

MS PLACER: Master List of Facilities

List includes aboveground tanks, underground tanks and cleanup sites.

Date of Government Version: 06/08/2020
Date Data Arrived at EDR: 06/10/2020
Date Made Active in Reports: 08/24/2020
Number of Days to Update: 75

Source: Placer County Health and Human Services
Telephone: 530-745-2363
Last EDR Contact: 08/25/2020
Next Scheduled EDR Contact: 12/14/2020
Data Release Frequency: Semi-Annually

PLUMAS COUNTY:

CUPA PLUMAS: CUPA Facility List

Plumas County CUPA Program facilities.

Date of Government Version: 03/31/2019
Date Data Arrived at EDR: 04/23/2019
Date Made Active in Reports: 06/26/2019
Number of Days to Update: 64

Source: Plumas County Environmental Health
Telephone: 530-283-6355
Last EDR Contact: 07/14/2020
Next Scheduled EDR Contact: 11/02/2020
Data Release Frequency: Varies

RIVERSIDE COUNTY:

LUST RIVERSIDE: Listing of Underground Tank Cleanup Sites

Riverside County Underground Storage Tank Cleanup Sites (LUST).

Date of Government Version: 03/10/2020
Date Data Arrived at EDR: 03/11/2020
Date Made Active in Reports: 05/20/2020
Number of Days to Update: 70

Source: Department of Environmental Health
Telephone: 951-358-5055
Last EDR Contact: 06/10/2020
Next Scheduled EDR Contact: 09/28/2020
Data Release Frequency: Quarterly

UST RIVERSIDE: Underground Storage Tank Tank List

Underground storage tank sites located in Riverside county.

Date of Government Version: 03/10/2020
Date Data Arrived at EDR: 03/11/2020
Date Made Active in Reports: 05/20/2020
Number of Days to Update: 70

Source: Department of Environmental Health
Telephone: 951-358-5055
Last EDR Contact: 06/10/2020
Next Scheduled EDR Contact: 09/28/2020
Data Release Frequency: Quarterly

SACRAMENTO COUNTY:

CS SACRAMENTO: Toxic Site Clean-Up List

List of sites where unauthorized releases of potentially hazardous materials have occurred.

GOVERNMENT RECORDS SEARCHED / DATA CURRENCY TRACKING

Date of Government Version: 02/18/2020
Date Data Arrived at EDR: 03/31/2020
Date Made Active in Reports: 06/15/2020
Number of Days to Update: 76

Source: Sacramento County Environmental Management
Telephone: 916-875-8406
Last EDR Contact: 07/02/2020
Next Scheduled EDR Contact: 10/12/2020
Data Release Frequency: Quarterly

ML SACRAMENTO: Master Hazardous Materials Facility List

Any business that has hazardous materials on site - hazardous material storage sites, underground storage tanks, waste generators.

Date of Government Version: 02/24/2020
Date Data Arrived at EDR: 03/31/2020
Date Made Active in Reports: 06/17/2020
Number of Days to Update: 78

Source: Sacramento County Environmental Management
Telephone: 916-875-8406
Last EDR Contact: 07/02/2020
Next Scheduled EDR Contact: 10/12/2020
Data Release Frequency: Quarterly

SAN BENITO COUNTY:

CUPA SAN BENITO: CUPA Facility List

Cupa facility list

Date of Government Version: 04/24/2020
Date Data Arrived at EDR: 04/28/2020
Date Made Active in Reports: 07/13/2020
Number of Days to Update: 76

Source: San Benito County Environmental Health
Telephone: N/A
Last EDR Contact: 07/28/2020
Next Scheduled EDR Contact: 11/16/2020
Data Release Frequency: Varies

SAN BERNARDINO COUNTY:

PERMITS SAN BERNARDINO: Hazardous Material Permits

This listing includes underground storage tanks, medical waste handlers/generators, hazardous materials handlers, hazardous waste generators, and waste oil generators/handlers.

Date of Government Version: 02/25/2020
Date Data Arrived at EDR: 02/26/2020
Date Made Active in Reports: 05/07/2020
Number of Days to Update: 71

Source: San Bernardino County Fire Department Hazardous Materials Division
Telephone: 909-387-3041
Last EDR Contact: 07/28/2020
Next Scheduled EDR Contact: 11/16/2020
Data Release Frequency: Quarterly

SAN DIEGO COUNTY:

HMMD SAN DIEGO: Hazardous Materials Management Division Database

The database includes: HE58 - This report contains the business name, site address, business phone number, establishment 'H' permit number, type of permit, and the business status. HE17 - In addition to providing the same information provided in the HE58 listing, HE17 provides inspection dates, violations received by the establishment, hazardous waste generated, the quantity, method of storage, treatment/disposal of waste and the hauler, and information on underground storage tanks. Unauthorized Release List - Includes a summary of environmental contamination cases in San Diego County (underground tank cases, non-tank cases, groundwater contamination, and soil contamination are included.)

Date of Government Version: 06/01/2020
Date Data Arrived at EDR: 06/02/2020
Date Made Active in Reports: 08/14/2020
Number of Days to Update: 73

Source: Hazardous Materials Management Division
Telephone: 619-338-2268
Last EDR Contact: 06/02/2020
Next Scheduled EDR Contact: 09/14/2020
Data Release Frequency: Quarterly

GOVERNMENT RECORDS SEARCHED / DATA CURRENCY TRACKING

LF SAN DIEGO: Solid Waste Facilities

San Diego County Solid Waste Facilities.

Date of Government Version: 04/18/2018
Date Data Arrived at EDR: 04/24/2018
Date Made Active in Reports: 06/19/2018
Number of Days to Update: 56

Source: Department of Health Services
Telephone: 619-338-2209
Last EDR Contact: 07/14/2020
Next Scheduled EDR Contact: 11/02/2020
Data Release Frequency: Varies

SAN DIEGO CO LOP: Local Oversight Program Listing

A listing of all LOP release sites that are or were under the County of San Diego's jurisdiction. Included are closed or transferred cases, open cases, and cases that did not have a case type indicated. The cases without a case type are mostly complaints; however, some of them could be LOP cases.

Date of Government Version: 04/09/2020
Date Data Arrived at EDR: 04/10/2020
Date Made Active in Reports: 06/26/2020
Number of Days to Update: 77

Source: Department of Environmental Health
Telephone: 858-505-6874
Last EDR Contact: 07/14/2020
Next Scheduled EDR Contact: 11/02/2020
Data Release Frequency: Varies

SAN DIEGO CO SAM: Environmental Case Listing

The listing contains all underground tank release cases and projects pertaining to properties contaminated with hazardous substances that are actively under review by the Site Assessment and Mitigation Program.

Date of Government Version: 03/23/2010
Date Data Arrived at EDR: 06/15/2010
Date Made Active in Reports: 07/09/2010
Number of Days to Update: 24

Source: San Diego County Department of Environmental Health
Telephone: 619-338-2371
Last EDR Contact: 08/25/2020
Next Scheduled EDR Contact: 12/14/2020
Data Release Frequency: No Update Planned

SAN FRANCISCO COUNTY:

LUST SAN FRANCISCO: Local Oversight Facilities

A listing of leaking underground storage tank sites located in San Francisco county.

Date of Government Version: 09/19/2008
Date Data Arrived at EDR: 09/19/2008
Date Made Active in Reports: 09/29/2008
Number of Days to Update: 10

Source: Department Of Public Health San Francisco County
Telephone: 415-252-3920
Last EDR Contact: 07/28/2020
Next Scheduled EDR Contact: 11/16/2020
Data Release Frequency: No Update Planned

UST SAN FRANCISCO: Underground Storage Tank Information

Underground storage tank sites located in San Francisco county.

Date of Government Version: 05/04/2020
Date Data Arrived at EDR: 05/06/2020
Date Made Active in Reports: 07/17/2020
Number of Days to Update: 72

Source: Department of Public Health
Telephone: 415-252-3920
Last EDR Contact: 07/28/2020
Next Scheduled EDR Contact: 11/16/2020
Data Release Frequency: Quarterly

SAN JOAQUIN COUNTY:

UST SAN JOAQUIN: San Joaquin Co. UST

A listing of underground storage tank locations in San Joaquin county.

Date of Government Version: 06/22/2018
Date Data Arrived at EDR: 06/26/2018
Date Made Active in Reports: 07/11/2018
Number of Days to Update: 15

Source: Environmental Health Department
Telephone: N/A
Last EDR Contact: 06/10/2020
Next Scheduled EDR Contact: 09/28/2020
Data Release Frequency: Semi-Annually

SAN LUIS OBISPO COUNTY:

GOVERNMENT RECORDS SEARCHED / DATA CURRENCY TRACKING

CUPA SAN LUIS OBISPO: CUPA Facility List Cupa Facility List.

Date of Government Version: 05/08/2020
Date Data Arrived at EDR: 05/08/2020
Date Made Active in Reports: 08/03/2020
Number of Days to Update: 87

Source: San Luis Obispo County Public Health Department
Telephone: 805-781-5596
Last EDR Contact: 08/11/2020
Next Scheduled EDR Contact: 11/30/2020
Data Release Frequency: Varies

SAN MATEO COUNTY:

BI SAN MATEO: Business Inventory

List includes Hazardous Materials Business Plan, hazardous waste generators, and underground storage tanks.

Date of Government Version: 02/20/2020
Date Data Arrived at EDR: 02/20/2020
Date Made Active in Reports: 04/24/2020
Number of Days to Update: 64

Source: San Mateo County Environmental Health Services Division
Telephone: 650-363-1921
Last EDR Contact: 06/12/2020
Next Scheduled EDR Contact: 09/21/2020
Data Release Frequency: Annually

LUST SAN MATEO: Fuel Leak List

A listing of leaking underground storage tank sites located in San Mateo county.

Date of Government Version: 03/29/2019
Date Data Arrived at EDR: 03/29/2019
Date Made Active in Reports: 05/29/2019
Number of Days to Update: 61

Source: San Mateo County Environmental Health Services Division
Telephone: 650-363-1921
Last EDR Contact: 06/03/2020
Next Scheduled EDR Contact: 09/21/2020
Data Release Frequency: Semi-Annually

SANTA BARBARA COUNTY:

CUPA SANTA BARBARA: CUPA Facility Listing

CUPA Program Listing from the Environmental Health Services division.

Date of Government Version: 09/08/2011
Date Data Arrived at EDR: 09/09/2011
Date Made Active in Reports: 10/07/2011
Number of Days to Update: 28

Source: Santa Barbara County Public Health Department
Telephone: 805-686-8167
Last EDR Contact: 08/11/2020
Next Scheduled EDR Contact: 11/30/2020
Data Release Frequency: No Update Planned

SANTA CLARA COUNTY:

CUPA SANTA CLARA: Cupa Facility List

Cupa facility list

Date of Government Version: 05/08/2020
Date Data Arrived at EDR: 05/12/2020
Date Made Active in Reports: 07/27/2020
Number of Days to Update: 76

Source: Department of Environmental Health
Telephone: 408-918-1973
Last EDR Contact: 08/11/2020
Next Scheduled EDR Contact: 11/30/2020
Data Release Frequency: Varies

HIST LUST SANTA CLARA: HIST LUST - Fuel Leak Site Activity Report

A listing of open and closed leaking underground storage tanks. This listing is no longer updated by the county. Leaking underground storage tanks are now handled by the Department of Environmental Health.

Date of Government Version: 03/29/2005
Date Data Arrived at EDR: 03/30/2005
Date Made Active in Reports: 04/21/2005
Number of Days to Update: 22

Source: Santa Clara Valley Water District
Telephone: 408-265-2600
Last EDR Contact: 03/23/2009
Next Scheduled EDR Contact: 06/22/2009
Data Release Frequency: No Update Planned

GOVERNMENT RECORDS SEARCHED / DATA CURRENCY TRACKING

LUST SANTA CLARA: LOP Listing

A listing of leaking underground storage tanks located in Santa Clara county.

Date of Government Version: 03/03/2014
Date Data Arrived at EDR: 03/05/2014
Date Made Active in Reports: 03/18/2014
Number of Days to Update: 13

Source: Department of Environmental Health
Telephone: 408-918-3417
Last EDR Contact: 08/19/2020
Next Scheduled EDR Contact: 12/07/2020
Data Release Frequency: No Update Planned

SAN JOSE HAZMAT: Hazardous Material Facilities

Hazardous material facilities, including underground storage tank sites.

Date of Government Version: 04/22/2020
Date Data Arrived at EDR: 04/24/2020
Date Made Active in Reports: 05/07/2020
Number of Days to Update: 13

Source: City of San Jose Fire Department
Telephone: 408-535-7694
Last EDR Contact: 07/28/2020
Next Scheduled EDR Contact: 11/16/2020
Data Release Frequency: Annually

SANTA CRUZ COUNTY:

CUPA SANTA CRUZ: CUPA Facility List

CUPA facility listing.

Date of Government Version: 01/21/2017
Date Data Arrived at EDR: 02/22/2017
Date Made Active in Reports: 05/23/2017
Number of Days to Update: 90

Source: Santa Cruz County Environmental Health
Telephone: 831-464-2761
Last EDR Contact: 08/11/2020
Next Scheduled EDR Contact: 11/30/2020
Data Release Frequency: Varies

SHASTA COUNTY:

CUPA SHASTA: CUPA Facility List

Cupa Facility List.

Date of Government Version: 06/15/2017
Date Data Arrived at EDR: 06/19/2017
Date Made Active in Reports: 08/09/2017
Number of Days to Update: 51

Source: Shasta County Department of Resource Management
Telephone: 530-225-5789
Last EDR Contact: 08/11/2020
Next Scheduled EDR Contact: 11/30/2020
Data Release Frequency: Varies

SOLANO COUNTY:

LUST SOLANO: Leaking Underground Storage Tanks

A listing of leaking underground storage tank sites located in Solano county.

Date of Government Version: 06/04/2019
Date Data Arrived at EDR: 06/06/2019
Date Made Active in Reports: 08/13/2019
Number of Days to Update: 68

Source: Solano County Department of Environmental Management
Telephone: 707-784-6770
Last EDR Contact: 08/25/2020
Next Scheduled EDR Contact: 12/14/2020
Data Release Frequency: Quarterly

UST SOLANO: Underground Storage Tanks

Underground storage tank sites located in Solano county.

Date of Government Version: 03/02/2020
Date Data Arrived at EDR: 03/04/2020
Date Made Active in Reports: 05/14/2020
Number of Days to Update: 71

Source: Solano County Department of Environmental Management
Telephone: 707-784-6770
Last EDR Contact: 08/25/2020
Next Scheduled EDR Contact: 12/14/2020
Data Release Frequency: Quarterly

SONOMA COUNTY:

GOVERNMENT RECORDS SEARCHED / DATA CURRENCY TRACKING

CUPA SONOMA: Cupa Facility List Cupa Facility list

Date of Government Version: 02/25/2020
Date Data Arrived at EDR: 02/26/2020
Date Made Active in Reports: 03/11/2020
Number of Days to Update: 14

Source: County of Sonoma Fire & Emergency Services Department
Telephone: 707-565-1174
Last EDR Contact: 06/30/2020
Next Scheduled EDR Contact: 10/05/2020
Data Release Frequency: Varies

LUST SONOMA: Leaking Underground Storage Tank Sites

A listing of leaking underground storage tank sites located in Sonoma county.

Date of Government Version: 04/03/2020
Date Data Arrived at EDR: 04/08/2020
Date Made Active in Reports: 06/26/2020
Number of Days to Update: 79

Source: Department of Health Services
Telephone: 707-565-6565
Last EDR Contact: 06/17/2020
Next Scheduled EDR Contact: 10/05/2020
Data Release Frequency: Quarterly

STANISLAUS COUNTY:

CUPA STANISLAUS: CUPA Facility List Cupa facility list

Date of Government Version: 02/04/2020
Date Data Arrived at EDR: 02/05/2020
Date Made Active in Reports: 04/15/2020
Number of Days to Update: 70

Source: Stanislaus County Department of Environmental Protection
Telephone: 209-525-6751
Last EDR Contact: 07/06/2020
Next Scheduled EDR Contact: 10/26/2020
Data Release Frequency: Varies

SUTTER COUNTY:

UST SUTTER: Underground Storage Tanks

Underground storage tank sites located in Sutter county.

Date of Government Version: 05/26/2020
Date Data Arrived at EDR: 05/28/2020
Date Made Active in Reports: 08/13/2020
Number of Days to Update: 77

Source: Sutter County Environmental Health Services
Telephone: 530-822-7500
Last EDR Contact: 08/25/2020
Next Scheduled EDR Contact: 12/14/2020
Data Release Frequency: Semi-Annually

TEHAMA COUNTY:

CUPA TEHAMA: CUPA Facility List Cupa facilities

Date of Government Version: 05/18/2020
Date Data Arrived at EDR: 05/19/2020
Date Made Active in Reports: 07/31/2020
Number of Days to Update: 73

Source: Tehama County Department of Environmental Health
Telephone: 530-527-8020
Last EDR Contact: 08/11/2020
Next Scheduled EDR Contact: 11/16/2020
Data Release Frequency: Varies

TRINITY COUNTY:

CUPA TRINITY: CUPA Facility List Cupa facility list

GOVERNMENT RECORDS SEARCHED / DATA CURRENCY TRACKING

Date of Government Version: 04/09/2020
Date Data Arrived at EDR: 04/10/2020
Date Made Active in Reports: 07/01/2020
Number of Days to Update: 82

Source: Department of Toxic Substances Control
Telephone: 760-352-0381
Last EDR Contact: 07/14/2020
Next Scheduled EDR Contact: 11/02/2020
Data Release Frequency: Varies

TULARE COUNTY:

CUPA TULARE: CUPA Facility List Cupa program facilities

Date of Government Version: 05/14/2020
Date Data Arrived at EDR: 05/15/2020
Date Made Active in Reports: 07/27/2020
Number of Days to Update: 73

Source: Tulare County Environmental Health Services Division
Telephone: 559-624-7400
Last EDR Contact: 08/06/2020
Next Scheduled EDR Contact: 11/16/2020
Data Release Frequency: Varies

TUOLUMNE COUNTY:

CUPA TUOLUMNE: CUPA Facility List Cupa facility list

Date of Government Version: 04/23/2018
Date Data Arrived at EDR: 04/25/2018
Date Made Active in Reports: 06/25/2018
Number of Days to Update: 61

Source: Divison of Environmental Health
Telephone: 209-533-5633
Last EDR Contact: 07/14/2020
Next Scheduled EDR Contact: 11/02/2020
Data Release Frequency: Varies

VENTURA COUNTY:

BWT VENTURA: Business Plan, Hazardous Waste Producers, and Operating Underground Tanks

The BWT list indicates by site address whether the Environmental Health Division has Business Plan (B), Waste Producer (W), and/or Underground Tank (T) information.

Date of Government Version: 03/26/2020
Date Data Arrived at EDR: 04/23/2020
Date Made Active in Reports: 07/09/2020
Number of Days to Update: 77

Source: Ventura County Environmental Health Division
Telephone: 805-654-2813
Last EDR Contact: 07/20/2020
Next Scheduled EDR Contact: 11/02/2020
Data Release Frequency: Quarterly

LF VENTURA: Inventory of Illegal Abandoned and Inactive Sites

Ventura County Inventory of Closed, Illegal Abandoned, and Inactive Sites.

Date of Government Version: 12/01/2011
Date Data Arrived at EDR: 12/01/2011
Date Made Active in Reports: 01/19/2012
Number of Days to Update: 49

Source: Environmental Health Division
Telephone: 805-654-2813
Last EDR Contact: 06/24/2020
Next Scheduled EDR Contact: 10/12/2020
Data Release Frequency: No Update Planned

LUST VENTURA: Listing of Underground Tank Cleanup Sites

Ventura County Underground Storage Tank Cleanup Sites (LUST).

Date of Government Version: 05/29/2008
Date Data Arrived at EDR: 06/24/2008
Date Made Active in Reports: 07/31/2008
Number of Days to Update: 37

Source: Environmental Health Division
Telephone: 805-654-2813
Last EDR Contact: 08/04/2020
Next Scheduled EDR Contact: 11/23/2020
Data Release Frequency: No Update Planned

GOVERNMENT RECORDS SEARCHED / DATA CURRENCY TRACKING

MED WASTE VENTURA: Medical Waste Program List

To protect public health and safety and the environment from potential exposure to disease causing agents, the Environmental Health Division Medical Waste Program regulates the generation, handling, storage, treatment and disposal of medical waste throughout the County.

Date of Government Version: 03/26/2020	Source: Ventura County Resource Management Agency
Date Data Arrived at EDR: 04/23/2020	Telephone: 805-654-2813
Date Made Active in Reports: 07/09/2020	Last EDR Contact: 07/20/2020
Number of Days to Update: 77	Next Scheduled EDR Contact: 11/02/2020
	Data Release Frequency: Quarterly

UST VENTURA: Underground Tank Closed Sites List

Ventura County Operating Underground Storage Tank Sites (UST)/Underground Tank Closed Sites List.

Date of Government Version: 05/26/2020	Source: Environmental Health Division
Date Data Arrived at EDR: 06/09/2020	Telephone: 805-654-2813
Date Made Active in Reports: 08/20/2020	Last EDR Contact: 06/09/2020
Number of Days to Update: 72	Next Scheduled EDR Contact: 09/21/2020
	Data Release Frequency: Quarterly

YOLO COUNTY:

UST YOLO: Underground Storage Tank Comprehensive Facility Report

Underground storage tank sites located in Yolo county.

Date of Government Version: 03/23/2020	Source: Yolo County Department of Health
Date Data Arrived at EDR: 04/01/2020	Telephone: 530-666-8646
Date Made Active in Reports: 06/17/2020	Last EDR Contact: 06/24/2020
Number of Days to Update: 77	Next Scheduled EDR Contact: 10/12/2020
	Data Release Frequency: Annually

YUBA COUNTY:

CUPA YUBA: CUPA Facility List

CUPA facility listing for Yuba County.

Date of Government Version: 04/27/2020	Source: Yuba County Environmental Health Department
Date Data Arrived at EDR: 04/29/2020	Telephone: 530-749-7523
Date Made Active in Reports: 07/17/2020	Last EDR Contact: 08/04/2020
Number of Days to Update: 79	Next Scheduled EDR Contact: 11/09/2020
	Data Release Frequency: Varies

OTHER DATABASE(S)

Depending on the geographic area covered by this report, the data provided in these specialty databases may or may not be complete. For example, the existence of wetlands information data in a specific report does not mean that all wetlands in the area covered by the report are included. Moreover, the absence of any reported wetlands information does not necessarily mean that wetlands do not exist in the area covered by the report.

CT MANIFEST: Hazardous Waste Manifest Data

Facility and manifest data. Manifest is a document that lists and tracks hazardous waste from the generator through transporters to a tsd facility.

Date of Government Version: 05/12/2020	Source: Department of Energy & Environmental Protection
Date Data Arrived at EDR: 05/12/2020	Telephone: 860-424-3375
Date Made Active in Reports: 07/27/2020	Last EDR Contact: 08/10/2020
Number of Days to Update: 76	Next Scheduled EDR Contact: 11/23/2020
	Data Release Frequency: No Update Planned

GOVERNMENT RECORDS SEARCHED / DATA CURRENCY TRACKING

NJ MANIFEST: Manifest Information

Hazardous waste manifest information.

Date of Government Version: 12/31/2018
Date Data Arrived at EDR: 04/10/2019
Date Made Active in Reports: 05/16/2019
Number of Days to Update: 36

Source: Department of Environmental Protection
Telephone: N/A
Last EDR Contact: 07/09/2020
Next Scheduled EDR Contact: 10/19/2020
Data Release Frequency: Annually

NY MANIFEST: Facility and Manifest Data

Manifest is a document that lists and tracks hazardous waste from the generator through transporters to a TSD facility.

Date of Government Version: 01/01/2019
Date Data Arrived at EDR: 04/29/2020
Date Made Active in Reports: 07/10/2020
Number of Days to Update: 72

Source: Department of Environmental Conservation
Telephone: 518-402-8651
Last EDR Contact: 07/31/2020
Next Scheduled EDR Contact: 11/09/2020
Data Release Frequency: Quarterly

PA MANIFEST: Manifest Information

Hazardous waste manifest information.

Date of Government Version: 06/30/2018
Date Data Arrived at EDR: 07/19/2019
Date Made Active in Reports: 09/10/2019
Number of Days to Update: 53

Source: Department of Environmental Protection
Telephone: 717-783-8990
Last EDR Contact: 07/09/2020
Next Scheduled EDR Contact: 10/26/2020
Data Release Frequency: Annually

RI MANIFEST: Manifest information

Hazardous waste manifest information

Date of Government Version: 12/31/2018
Date Data Arrived at EDR: 10/02/2019
Date Made Active in Reports: 12/10/2019
Number of Days to Update: 69

Source: Department of Environmental Management
Telephone: 401-222-2797
Last EDR Contact: 08/11/2020
Next Scheduled EDR Contact: 11/30/2020
Data Release Frequency: Annually

WI MANIFEST: Manifest Information

Hazardous waste manifest information.

Date of Government Version: 05/31/2018
Date Data Arrived at EDR: 06/19/2019
Date Made Active in Reports: 09/03/2019
Number of Days to Update: 76

Source: Department of Natural Resources
Telephone: N/A
Last EDR Contact: 06/04/2020
Next Scheduled EDR Contact: 09/21/2020
Data Release Frequency: Annually

Oil/Gas Pipelines

Source: Endeavor Business Media

Petroleum Bundle (Crude Oil, Refined Products, Petrochemicals, Gas Liquids (LPG/NGL), and Specialty Gases (Miscellaneous)) N = Natural Gas Bundle (Natural Gas, Gas Liquids (LPG/NGL), and Specialty Gases (Miscellaneous)). This map includes information copyrighted by Endeavor Business Media. This information is provided on a best effort basis and Endeavor Business Media does not guarantee its accuracy nor warrant its fitness for any particular purpose. Such information has been reprinted with the permission of Endeavor Business Media.

Electric Power Transmission Line Data

Source: Endeavor Business Media

This map includes information copyrighted by Endeavor Business Media. This information is provided on a best effort basis and Endeavor Business Media does not guarantee its accuracy nor warrant its fitness for any particular purpose. Such information has been reprinted with the permission of Endeavor Business Media.

Sensitive Receptors: There are individuals deemed sensitive receptors due to their fragile immune systems and special sensitivity to environmental discharges. These sensitive receptors typically include the elderly, the sick, and children. While the location of all sensitive receptors cannot be determined, EDR indicates those buildings and facilities - schools, daycares, hospitals, medical centers, and nursing homes - where individuals who are sensitive receptors are likely to be located.

GOVERNMENT RECORDS SEARCHED / DATA CURRENCY TRACKING

AHA Hospitals:

Source: American Hospital Association, Inc.

Telephone: 312-280-5991

The database includes a listing of hospitals based on the American Hospital Association's annual survey of hospitals.

Medical Centers: Provider of Services Listing

Source: Centers for Medicare & Medicaid Services

Telephone: 410-786-3000

A listing of hospitals with Medicare provider number, produced by Centers of Medicare & Medicaid Services, a federal agency within the U.S. Department of Health and Human Services.

Nursing Homes

Source: National Institutes of Health

Telephone: 301-594-6248

Information on Medicare and Medicaid certified nursing homes in the United States.

Public Schools

Source: National Center for Education Statistics

Telephone: 202-502-7300

The National Center for Education Statistics' primary database on elementary and secondary public education in the United States. It is a comprehensive, annual, national statistical database of all public elementary and secondary schools and school districts, which contains data that are comparable across all states.

Private Schools

Source: National Center for Education Statistics

Telephone: 202-502-7300

The National Center for Education Statistics' primary database on private school locations in the United States.

Daycare Centers: Licensed Facilities

Source: Department of Social Services

Telephone: 916-657-4041

Flood Zone Data: This data was obtained from the Federal Emergency Management Agency (FEMA). It depicts 100-year and 500-year flood zones as defined by FEMA. It includes the National Flood Hazard Layer (NFHL) which incorporates Flood Insurance Rate Map (FIRM) data and Q3 data from FEMA in areas not covered by NFHL.

Source: FEMA

Telephone: 877-336-2627

Date of Government Version: 2003, 2015

NWI: National Wetlands Inventory. This data, available in select counties across the country, was obtained by EDR in 2002, 2005 and 2010 from the U.S. Fish and Wildlife Service.

State Wetlands Data: Wetland Inventory

Source: Department of Fish and Wildlife

Telephone: 916-445-0411

STREET AND ADDRESS INFORMATION

© 2015 TomTom North America, Inc. All rights reserved. This material is proprietary and the subject of copyright protection and other intellectual property rights owned by or licensed to Tele Atlas North America, Inc. The use of this material is subject to the terms of a license agreement. You will be held liable for any unauthorized copying or disclosure of this material.

APPENDIX F

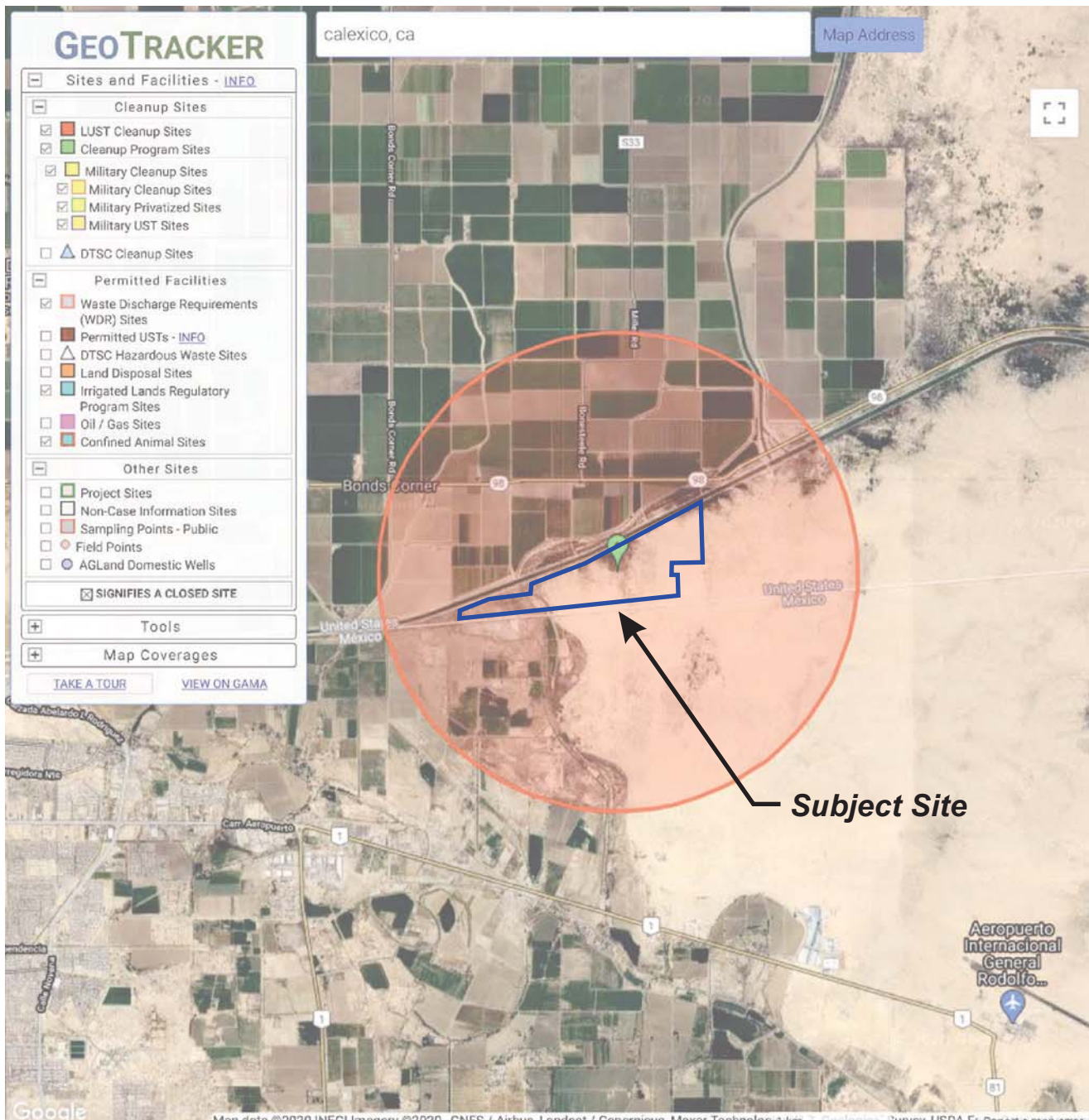
PC ORIGINAL PKG

GEOTRACKER

calexico, ca

Map Address

- Sites and Facilities - INFO
- Cleanup Sites
 - LUST Cleanup Sites
 - Cleanup Program Sites
 - Military Cleanup Sites
 - Military Cleanup Sites
 - Military Privatized Sites
 - Military UST Sites
 - DTSC Cleanup Sites
- Permitted Facilities
 - Waste Discharge Requirements (WDR) Sites
 - Permitted USTs - INFO
 - DTSC Hazardous Waste Sites
 - Land Disposal Sites
 - Irrigated Lands Regulatory Program Sites
 - Oil / Gas Sites
 - Confined Animal Sites
- Other Sites
 - Project Sites
 - Non-Case Information Sites
 - Sampling Points - Public
 - Field Points
 - AGLand Domestic Wells
- SIGNIFIES A CLOSED SITE
- Tools
- Map Coverages
 - TAKE A TOUR
 - VIEW ON GAMA



Subject Site

SITES FOUND IN SEARCH RADIUS 0 SITES LISTED EXPORT THIS LIST TO EXCEL

SITE NAME	GLOBAL ID	STATUS	ADDRESS	CITY
-----------	-----------	--------	---------	------



Project No.: GS2015

Geotracker Map

Plate 15

PC ORIGINAL PKG

ENVIROSTOR

calexico, ca

Map Address

Sites and Facilities

Cleanup Sites

- Federal Superfund
- State Response
- Voluntary Cleanup
- School Cleanup
- Evaluation
- School Investigation
- Military Evaluation
- Tiered Permit
- Corrective Action
- Field Points

STATUS

All Statuses

Permitted Sites

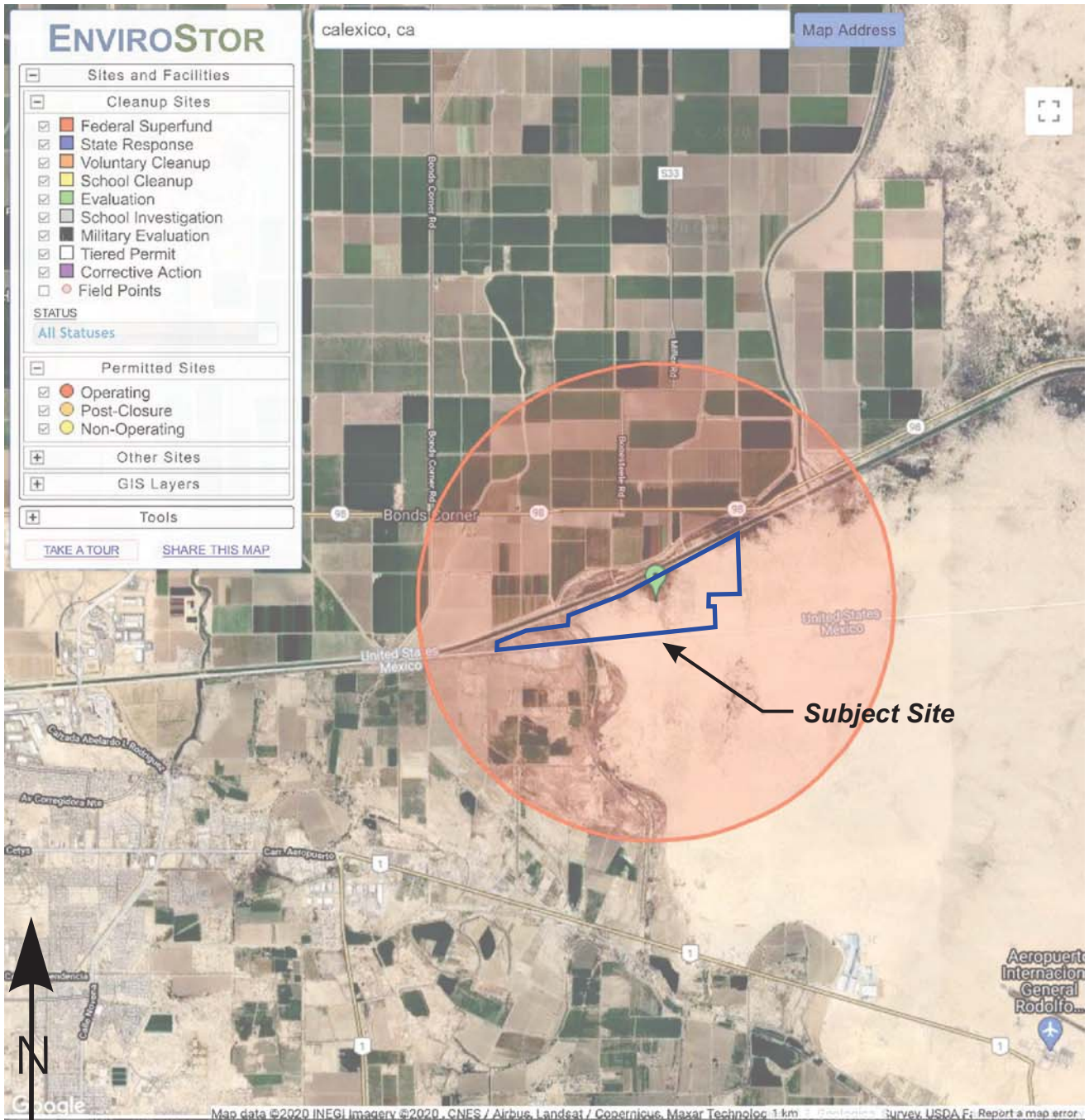
- Operating
- Post-Closure
- Non-Operating

Other Sites

GIS Layers

Tools

[TAKE A TOUR](#) [SHARE THIS MAP](#)



SITES FOUND IN SEARCH RADIUS: 0 SITES LISTED

[EXPORT THIS LIST TO EXCEL](#)

PROJECT NAME	STATUS	PROJECT TYPE	ADDRESS	CITY



Project No.: GS2015

Envirostor Map

Plate
16

PC ORIGINAL PKG

APPENDIX G

PC ORIGINAL PKG

Issuing Policies of Fidelity National Title Insurance Company

Title Officer: Mitch LaRiva
Escrow Officer: Major Accounts OAC

Order No.: 997-30053824-ML6

TO:
ZGlobal
604 Sutter Street, Suite 250
Folsom, CA 95630

ATTN: **Jamie Nichole Nagel**
YOUR REFERENCE: **059-300-015 SLATER**

PROPERTY ADDRESS: APN'S #059-300-015-000, 059-300-017-000 and 059-290-010-000, County of Imperial, CA

PRELIMINARY REPORT

*In response to the application for a policy of title insurance referenced herein, **Fidelity National Title Company** hereby reports that it is prepared to issue, or cause to be issued, as of the date hereof, a policy or policies of title insurance describing the land and the estate or interest therein hereinafter set forth, insuring against loss which may be sustained by reason of any defect, lien or encumbrance not shown or referred to as an exception herein or not excluded from coverage pursuant to the printed Schedules, Conditions and Stipulations or Conditions of said policy forms.*

The printed Exceptions and Exclusions from the coverage and Limitations on Covered Risks of said policy or policies are set forth in Attachment One. The policy to be issued may contain an arbitration clause. When the Amount of Insurance is less than that set forth in the arbitration clause, all arbitrable matters shall be arbitrated at the option of either the Company or the Insured as the exclusive remedy of the parties. Limitations on Covered Risks applicable to the CLTA and ALTA Homeowner's Policies of Title Insurance which establish a Deductible Amount and a Maximum Dollar Limit of Liability for certain coverages are also set forth in Attachment One. Copies of the policy forms should be read. They are available from the office which issued this report.

This report (and any supplements or amendments hereto) is issued solely for the purpose of facilitating the issuance of a policy of title insurance and no liability is assumed hereby. If it is desired that liability be assumed prior to the issuance of a policy of title insurance, a Binder or Commitment should be requested.

The policy(s) of title insurance to be issued hereunder will be policy(s) of Fidelity National Title Insurance Company, a Florida Corporation.

Please read the exceptions shown or referred to herein and the exceptions and exclusions set forth in Attachment One of this report carefully. The exceptions and exclusions are meant to provide you with notice of matters which are not covered under the terms of the title insurance policy and should be carefully considered.

It is important to note that this preliminary report is not a written representation as to the condition of title and may not list all liens, defects and encumbrances affecting title to the land.

Countersigned by:



Authorized Signature

PRELIMINARY REPORT

EFFECTIVE DATE: August 31, 2020 at 7:30 a.m.

ORDER NO.: 997-30053824-ML6

The form of policy or policies of title insurance contemplated by this report is:

ALTA Standard Owners Policy (6-17-06)

1. THE ESTATE OR INTEREST IN THE LAND HEREINAFTER DESCRIBED OR REFERRED TO COVERED BY THIS REPORT IS:

A FEE

2. TITLE TO SAID ESTATE OR INTEREST AT THE DATE HEREOF IS VESTED IN:

TAMMY CHERI SLATER and JIMMIE R. DOYLE, Successor Co-Trustees of the EXEMPTION TRUST under the DOYLE FAMILY 2010 TRUST, dated August 13, 2010, as to an undivided 92.9% interest and TAMMY CHERI SLATER and JIMMIE R. DOYLE, Successor Co-Trustees of the SURVIVOR'S TRUST under the DOYLE FAMILY 2010 TRUST, dated August 13, 2010, as to an undivided 7.1% interest, subject to Item No. 24 of Exceptions and Item No's. 1 and 2 of Requirements

3. THE LAND REFERRED TO IN THIS REPORT IS DESCRIBED AS FOLLOWS:

See Exhibit A attached hereto and made a part hereof.

EXHIBIT A LEGAL DESCRIPTION

THE LAND REFERRED TO HEREIN BELOW IS SITUATED IN THE UNINCORPORATED AREA OF COUNTY OF IMPERIAL, COUNTY OF IMPERIAL, STATE OF CALIFORNIA, AND IS DESCRIBED AS FOLLOWS:

PARCEL 1:

THOSE PORTIONS OF LOTS 13, 20 AND 21, AND THE SOUTHWEST QUARTER OF THE SOUTHEAST QUARTER OF SECTION 10, LYING SOUTH OF THE ALL-AMERICAN CANAL, TOWNSHIP 17 SOUTH, RANGE 16 EAST, SAN BERNARDINO MERIDIAN, IN AN UNINCORPORATED AREA OF THE COUNTY OF IMPERIAL, STATE OF CALIFORNIA, ACCORDING TO THE OFFICIAL PLAT THEREOF.

PORTION OF [APN: 059-300-015-000](#)

PARCEL 2:

LOTS 11, 13, 15 AND THE NORTH HALF OF THE SOUTHEAST QUARTER OF SECTION 11, TOWNSHIP 17 SOUTH, RANGE 16 EAST, SAN BERNARDINO MERIDIAN, IN AN UNINCORPORATED AREA OF THE COUNTY OF IMPERIAL, STATE OF CALIFORNIA, ACCORDING TO THE OFFICIAL PLAT THEREOF.

PORTION OF [APN: 059-300-015-000](#)

PARCEL 3:

THOSE PORTIONS OF LOTS 6, 7 AND 10, AND THE NORTHEAST QUARTER OF SECTION 11, LYING SOUTH OF THE ALL-AMERICAN CANAL, TOWNSHIP 17 SOUTH, RANGE 16 EAST, SAN BERNARDINO MERIDIAN, IN AN UNINCORPORATED AREA OF THE COUNTY OF IMPERIAL, STATE OF CALIFORNIA, ACCORDING TO THE OFFICIAL PLAT THEREOF.

PORTION OF [APN: 059-300-015-000](#)

PARCEL 4:

TRACT 41, TOWNSHIP 17 SOUTH, RANGE 16 EAST, SAN BERNARDINO MERIDIAN, IN AN UNINCORPORATED AREA OF THE COUNTY OF IMPERIAL, STATE OF CALIFORNIA, ACCORDING TO THE OFFICIAL PLAT THEREOF.

EXCEPTING THEREFROM ONE-HALF OF ALL STEAM, MINERALS, OILS, GAS, WATER, CARBONS AND HYDROCARBONS ON OR UNDER THE HEREIN DESCRIBED PROPERTY, AS RESERVED BY NATALIE KAPLAN BY DEED RECORDED APRIL 5, 1979 AS DOCUMENT NO. 3 IN [BOOK 1431, PAGE 1454](#), OF OFFICIAL RECORDS.

ALSO EXCEPTING THEREFROM THE SOUTH 60 FEET THEREOF AS TAKEN BY THE UNITED STATES OF AMERICA IN DECLARATION OF TAKING RECORDED AUGUST 8, 2008 AS [DOCUMENT NO. 2008-023038, OF OFFICIAL RECORDS](#).

[APN: 059-300-017-000](#)

EXHIBIT A
(Continued)

PARCEL 5:

LOTS 2, 3, 4 AND 7, SECTION 15 AND THAT PORTION OF LOT 3, SECTION 16, LYING SOUTHERLY OF THE ALL- AMERICAN CANAL, ALL IN TOWNSHIP 17 SOUTH, RANGE 16 EAST, SAN BERNARDINO MERIDIAN, IN AN UNINCORPORATED AREA OF THE COUNTY OF IMPERIAL, STATE OF CALIFORNIA, ACCORDING TO THE OFFICIAL PLAT THEREOF.

EXCEPTING THEREFROM ANY PORTIONS THEREOF LYING WITHIN THE PUBLIC RESERVE, BEING THE SOUTH 60 FEET, LYING ADJACENT TO THE INTERNATIONAL BORDER BETWEEN THE UNITED STATES AND MEXICO, AS SET OUT BY PRESIDENTIAL PROCLAMATION DATED MAY 27, 1907 (35 STATS, 2186).

[APN: 059-290-010-000](#)

EXCEPTIONS

AT THE DATE HEREOF, ITEMS TO BE CONSIDERED AND EXCEPTIONS TO COVERAGE IN ADDITION TO THE PRINTED EXCEPTIONS AND EXCLUSIONS IN SAID POLICY FORM WOULD BE AS FOLLOWS:

A. Property taxes, including any personal property taxes and any assessments collected with taxes, are as follows:

Tax Identification No.: 059-300-015-000
Fiscal Year: 2020-2021
1st Installment: \$1,369.48, OPEN (Delinquent after December 10)
Penalty: \$136.94
2nd Installment: \$1,369.48, OPEN (Delinquent after April 10)
Penalty and Cost: \$146.94
Homeowners Exemption: \$0.00
Code Area: 068-012

Affects: Parcels 1, 2 and 3.

Property taxes, including any personal property taxes and any assessments collected with taxes, are as follows:

Tax Identification No.: 059-300-017-000
Fiscal Year: 2020-2021
1st Installment: \$374.67, OPEN (Delinquent after December 10)
Penalty: \$37.46
2nd Installment: \$374.67, OPEN (Delinquent after April 10)
Penalty and Cost: \$47.46
Homeowners Exemption: \$0.00
Code Area: 068-012

Affects: Parcel 4.

Property taxes, including any personal property taxes and any assessments collected with taxes, are as follows:

Tax Identification No.: 059-290-010-000
Fiscal Year: 2020-2021
1st Installment: \$204.52, OPEN (Delinquent after December 10)
Penalty: \$20.45
2nd Installment: \$204.52, OPEN (Delinquent after April 10)
Penalty and Cost: \$30.45
Homeowners Exemption: \$0.00
Code Area: 068-012

Affects: Parcel 5.

- B. Taxes and assessments levied by the Imperial Irrigation District.
- C. The lien of supplemental or escaped assessments of property taxes, if any, made pursuant to the provisions of Chapter 3.5 (commencing with Section 75) or Part 2, Chapter 3, Articles 3 and 4, respectively, of the Revenue and Taxation Code of the State of California as a result of the transfer of title to the vestee named in Schedule A or as a result of changes in ownership or new construction occurring prior to Date of Policy.

**EXCEPTIONS
(Continued)**

1. Water rights, claims or title to water, whether or not disclosed by the public records.
2. Easement(s) in favor of the public over any existing roads lying within said Land.
3. Lack of right of access to and from a public street or highway.
4. Rights or claims of easements for canals, drains, laterals, irrigation pipelines and gates not recorded in the public record.
5. Title to, and easements in, any portion of the land lying within any highways, roads, streets, or other ways.
6. The herein described Land is located in an area frequently subject to Land Conservation Contracts executed pursuant to the Williamson Act (Cal. Govt. Code §§ 51200 et seq.). Land Conservation Contracts restrict the land use to agricultural, recreational, open-space and other compatible uses. If the herein described Land is subject to a Land Conservation Contract, please notify the Title Department.

The Company reserves the right to add additional items and/or make further requirements.

7. Canal right of way, dated October 4, 1915, Serial No. LA 026139 by Act of Congress March 3, 1891, as disclosed by the District Land Office of the Bureau of Land Management.

Affects: Lot 3 in Section 15 of Parcel 5.

8. Reservations contained in the Patent

From: The United States of America
Recording Date: February 16, 1916
Recording No: 20, [Book 7, Page 207](#), of Patents

Which among other things recites as follows:

Subject to any vested and accrued water rights for mining, agricultural, manufacturing, or other purposes and rights to ditches and reservoirs used in connection with such water rights, as may be recognized and acknowledged by the local customs, laws and decisions of the courts, and the reservation from the lands hereby granted, a right of way thereon for ditches or canals constructed by the authority of the United States.

Affects: Parcels 1 and 5.

**EXCEPTIONS
(Continued)**

9. Reservations contained in the Patent

From: The United States of America
Recording Date: August 20, 1919
Recording No: 24, [Book 9, Page 88](#), of Patents

Which among other things recites as follows:

Subject to any vested and accrued water rights for mining, agricultural, manufacturing, or other purposes and rights to ditches and reservoirs used in connection with such water rights, as may be recognized and acknowledged by the local customs, laws and decisions of the courts, and the reservation from the lands hereby granted, a right of way thereon for ditches or canals constructed by the authority of the United States.

Affects: A portion of Parcels 1, 2 and 3.

10. Easement(s) for the purpose(s) shown below and rights incidental thereto, as granted in a document:

Granted to: Imperial Water Company
Purpose: Irrigation purposes
Recording Date: March 26, 1913
Recording No: 33, [Book 69, Page 386](#), of Deeds
Affects: Parcel 3.

11. Matters contained in that certain document

Entitled: Agreement
Dated: July 26, 1923
Executed by: Imperial Irrigation District and Will Kimberly, et al.
Recording Date: December 1, 1924
Recording No: 90, [Book 68, Page 165](#), of Official Records

Reference is hereby made to said document for full particulars.

Among other things, said document provides for: Drainage ditches.

Affects: A right of way whose width shall not exceed one hundred and fifty (150) feet across, over Lots 3 and 4, in Section 15, as shown on the map attached to said document.

Affects: Parcel 5.

**EXCEPTIONS
(Continued)**

12. Reservations contained in the Patent

From: The United States of America
Recording Date: October 4, 1928
Recording No: 34, [Book 206, Page 223](#), of Official Records

Which among other things recites as follows:

Subject to any vested and accrued water rights for mining, agricultural, manufacturing, or other purposes and rights to ditches and reservoirs used in connection with such water rights, as may be recognized and acknowledged by the local customs, laws and decisions of the courts, and the reservation from the lands hereby granted, a right of way thereon for ditches or canals constructed by the authority of the United States.

Affects: Parcels 2 and 3.

13. Easement(s) for the purpose(s) shown below and rights incidental thereto, as granted in a document:

Granted to: Imperial Irrigation District
Purpose: Canal, telephone and power lines
Recording Date: November 4, 1952
Recording No: [Book 849, Page 666](#), of Official Records
Affects: A portion of said land as more particularly described in said document.

Affects: Parcels 2 and 3.

14. Easement(s) for the purpose(s) shown below and rights incidental thereto, as granted in a document:

Granted to: Imperial Irrigation District
Purpose: Canal, telephone and power lines
Recording Date: December 4, 1952
Recording No: [Book 849, Page 668](#), of Official Records
Affects: A portion of said land as more particularly described in said document.

Affects: Parcel 1.

15. Easement(s) for the purpose(s) shown below and rights incidental thereto as reserved in a document;

Reserved by: Imperial Irrigation District
Purpose: Irrigation, waste or drainage canals, or power or telephone lines and incidental purposes
Recording Date: December 5, 1952
Recording No: 23, [Book 851, Page 42](#), of Official Records
Affects: Parcels 2 and 3.

**EXCEPTIONS
(Continued)**

16. Matters contained in that certain document

Entitled: Agreement
Dated: April 12, 1977
Executed by: The Imperial Irrigation District and Earl A. Silzle, et ux.
Recording Date: April 19, 1977
Recording No: [Book 1400, Page 583](#), of Official Records

Reference is hereby made to said document for full particulars.

Among other things, said document provides for: Water delivery.

Affects: Parcels 1, 2 and 3.

17. Matters contained in that certain document

Entitled: Agreement
Dated: December 20, 1977
Executed by: Imperial Irrigation District and Earl A. Silzle, et ux.
Recording Date: January 4, 1978
Recording No: [Book 1410, Page 1432](#), of Official Records

Reference is hereby made to said document for full particulars.

Among other things, said document provides for: Operation and maintenance of the Verde Drain.

Affects: Parcels 1, 2 and 3.

18. Easement(s) for the purpose(s) shown below and rights incidental thereto as reserved in a document;

Reserved by: Imperial Irrigation District
Purpose: Irrigation, waste or drainage canals or power or telephone lines
Recording Date: April 5, 1979
Recording No: 1, [Book 1431, Page 1450](#), of Official Records
Affects: Parcel 4.

19. An unrecorded oil and gas lease for the term therein provided, with certain covenants, conditions and provisions, together with easements, if any, as set forth therein, disclosed by document

Entitled: Short Form of Lease and Agreement
Lessor: E. A. Silzle, et ux.
Lessee: Occidental Geothermal, Inc.
Recording Date: April 6, 1979
Recording No: [Book 1431, Page 1613](#), of Official Records

No assurance is made as to the present ownership of the leasehold created by said lease, nor as to other matters affecting the rights or interests of the lessor or lessee in said lease.

Affects: Parcels 1, 2 and 3.

**EXCEPTIONS
(Continued)**

20. An oil and gas lease for the term therein provided with certain covenants, conditions and provisions, together with easements, if any, as set forth therein.

Dated: July 14, 1981
Lessor: Bill Silzle, aka William Silzle, a married man dealing with his sole and separate property
Lessee: Emefco Petroleum, Inc.
Recording Date: August 28, 1981
Recording No: 52, [Book 1474, Page 49](#), of Official Records

No assurance is made as to the present ownership of the leasehold created by said lease, nor as to other matters affecting the rights or interests of the lessor or lessee in said lease.

Affects: Parcel 5.

21. An oil and gas lease for the term therein provided with certain covenants, conditions and provisions, together with easements, if any, as set forth therein.

Dated: July 14, 1981
Lessor: The Jet B Corporation, Inc., a California corporation
Lessee: Emefco Petroleum, Inc.
Recording Date: August 28, 1981
Recording No: 58, [Book 1474, Page 63](#), of Official Records

No assurance is made as to the present ownership of the leasehold created by said lease, nor as to other matters affecting the rights or interests of the lessor or lessee in said lease.

Affects: Parcels 1, 2 and 3.

22. An oil and gas lease for the term therein provided with certain covenants, conditions and provisions, together with easements, if any, as set forth therein.

Dated: June 14, 1981
Lessor: William Silzle, aka Bill Silzle and Barbara B. Bilzle, husband and wife as joint tenants
Lessee: Emefco Petroleum, Inc.
Recording Date: September 3, 1981
Recording No: 21, [Book 1474, Page 628](#), of Official Records

No assurance is made as to the present ownership of the leasehold created by said lease, nor as to other matters affecting the rights or interests of the lessor or lessee in said lease.

Affects: Parcel 4.

**EXCEPTIONS
(Continued)**

23. An option to purchase said Land with certain terms, covenants, conditions and provisions as set forth therein.

Optionor: Tammy Cheri Slater and Jimmie R. Doyle, Co-Trustees of the Exemption Trust under the Doyle Family 2010 Trust dated August 13, 2010 and Tammy Cheri Slater and Jimmie R. Doyle, Co-Trustees of the Survivor's Trust under the Doyle Family 2010 Trust, dated August 13, 2010

Optionee: Apex Energy Solutions, LLC, a California limited liability company

Disclosed by: Memorandum of Option for Purchase of Real Property

Recording Date: October 15, 2019

Recording No: [2019020829, of Official Records](#)

24. Any invalidity or defect in the title of the vestees in the event that the trust referred to herein is invalid or fails to grant sufficient powers to the trustee(s) or in the event there is a lack of compliance with the terms and provisions of the trust instrument.

If title is to be insured in the trustee(s) of a trust, (or if their act is to be insured), this Company will require a Trust Certification pursuant to California Probate Code Section 18100.5.

The Company reserves the right to add additional items or make further requirements after review of the requested documentation.

25. Please be advised that our search did not disclose any open Deeds of Trust of record. If you should have knowledge of any outstanding obligation, please contact the Title Department immediately for further review prior to closing.

26. Any rights of the parties in possession of a portion of, or all of, said Land, which rights are not disclosed by the public records.

The Company will require, for review, a full and complete copy of any unrecorded agreement, contract, license and/or lease, together with all supplements, assignments and amendments thereto, before issuing any policy of title insurance without excepting this item from coverage.

The Company reserves the right to except additional items and/or make additional requirements after reviewing said documents.

27. Any easements not disclosed by the public records as to matters affecting title to real property, whether or not said easements are visible and apparent.

28. Matters which may be disclosed by an inspection and/or by a correct ALTA/NSPS Land Title Survey of said Land that is satisfactory to the Company, and/or by inquiry of the parties in possession thereof.

PLEASE REFER TO THE "INFORMATIONAL NOTES" AND "REQUIREMENTS" SECTIONS WHICH FOLLOW FOR INFORMATION NECESSARY TO COMPLETE THIS TRANSACTION.

END OF EXCEPTIONS

REQUIREMENTS SECTION

1. The Company will require either (a) a complete copy of the trust agreement and any amendments thereto certified by the trustee(s) to be a true and complete copy with respect to the hereinafter named trust, or (b) a Certification, pursuant to California Probate Code Section 18100.5, executed by all of the current trustee(s) of the hereinafter named trust, a form of which is attached.

Name of Trust: The Exemption Trust under the Doyle Family 2010 Trust, dated August 13, 2010

2. The Company will require either (a) a complete copy of the trust agreement and any amendments thereto certified by the trustee(s) to be a true and complete copy with respect to the hereinafter named trust, or (b) a Certification, pursuant to California Probate Code Section 18100.5, executed by all of the current trustee(s) of the hereinafter named trust, a form of which is attached.

Name of Trust: The Survivor's Trust under the Doyle Family 2010 Trust, dated August 13, 2010

3. Prior to the close of escrow, the Company requires a Statement of Information to be completed by the following party(s),

Party(s): All Parties

The Company reserves the right to add additional items or make further requirements after review of the requested Statement of Information.

4. Unrecorded matters which may be disclosed by an Owner's Affidavit or Declaration. A form of the Owner's Affidavit/Declaration is attached to this Preliminary Report/Commitment. This Affidavit/Declaration is to be completed by the record owner of the land and submitted for review prior to the closing of this transaction. Your prompt attention to this requirement will help avoid delays in the closing of this transaction. Thank you.

The Company reserves the right to add additional items or make further requirements after review of the requested Affidavit/Declaration.

END OF REQUIREMENTS

INFORMATIONAL NOTES SECTION

1. Note: The policy of title insurance will include an arbitration provision. The Company or the insured may demand arbitration. Arbitrable matters may include, but are not limited to, any controversy or claim between the Company and the insured arising out of or relating to this policy, any service of the Company in connection with its issuance or the breach of a policy provision or other obligation. Please ask your escrow or title officer for a sample copy of the policy to be issued if you wish to review the arbitration provisions and any other provisions pertaining to your Title Insurance coverage.
2. Notice: Please be aware that due to the conflict between federal and state laws concerning the cultivation, distribution, manufacture or sale of marijuana, the Company is not able to close or insure any transaction involving Land that is associated with these activities.
3. Pursuant to Government Code Section 27388.1, as amended and effective as of 1-1-2018, a Documentary Transfer Tax (DTT) Affidavit may be required to be completed and submitted with each document when DTT is being paid or when an exemption is being claimed from paying the tax. If a governmental agency is a party to the document, the form will not be required. DTT Affidavits may be available at a Tax Assessor-County Clerk-Recorder.
4. Due to the special requirements of SB 50 (California Public Resources Code Section 8560 et seq.), any transaction that includes the conveyance of title by an agency of the United States must be approved in advance by the Company's State Counsel, Regional Counsel, or one of their designees.
5. Note: The only conveyance(s) affecting said Land, which recorded within 24 months of the date of this report, are as follows:

Grantor:	Jimmy C. Doyle, decedent
Grantee:	Jimmie R. Doyle and Tammy Cheri Slater, Successor Trustees of the Doyle Family 2010 Trust
Recording Date:	August 30, 2019
<u>Recording No:</u>	<u>2019016567, of Official Records</u>

END OF INFORMATIONAL NOTES

Mitch LaRiva/717

Wire Fraud Alert

This Notice is not intended to provide legal or professional advice. If you have any questions, please consult with a lawyer.

All parties to a real estate transaction are targets for wire fraud and many have lost hundreds of thousands of dollars because they simply relied on the wire instructions received via email, without further verification. **If funds are to be wired in conjunction with this real estate transaction, we strongly recommend verbal verification of wire instructions through a known, trusted phone number prior to sending funds.**

In addition, the following non-exclusive self-protection strategies are recommended to minimize exposure to possible wire fraud.

- **NEVER RELY** on emails purporting to change wire instructions. Parties to a transaction rarely change wire instructions in the course of a transaction.
- **ALWAYS VERIFY** wire instructions, specifically the ABA routing number and account number, by calling the party who sent the instructions to you. DO NOT use the phone number provided in the email containing the instructions, use phone numbers you have called before or can otherwise verify. **Obtain the phone number of relevant parties to the transaction as soon as an escrow account is opened.** DO NOT send an email to verify as the email address may be incorrect or the email may be intercepted by the fraudster.
- **USE COMPLEX EMAIL PASSWORDS** that employ a combination of mixed case, numbers, and symbols. Make your passwords greater than eight (8) characters. Also, change your password often and do NOT reuse the same password for other online accounts.
- **USE MULTI-FACTOR AUTHENTICATION** for email accounts. Your email provider or IT staff may have specific instructions on how to implement this feature.

For more information on wire-fraud scams or to report an incident, please refer to the following links:

Federal Bureau of Investigation:
<http://www.fbi.gov>

Internet Crime Complaint Center:
<http://www.ic3.gov>

Fidelity National Title Company

4210 Riverwalk Parkway, Suite 200
 Riverside, CA 92505
 Phone: (951) 710-5912 • Fax:

Notice of Available Discounts

Pursuant to Section 2355.3 in Title 10 of the California Code of Regulations Fidelity National Financial, Inc. and its subsidiaries ("FNF") must deliver a notice of each discount available under our current rate filing along with the delivery of escrow instructions, a preliminary report or commitment. Please be aware that the provision of this notice does not constitute a waiver of the consumer's right to be charged the filed rate. As such, your transaction may not qualify for the below discounts.

You are encouraged to discuss the applicability of one or more of the below discounts with a Company representative. These discounts are generally described below; consult the rate manual for a full description of the terms, conditions and requirements for such discount. These discounts only apply to transactions involving services rendered by the FNF Family of Companies. This notice only applies to transactions involving property improved with a one-to-four family residential dwelling.

Not all discounts are offered by every FNF Company. The discount will only be applicable to the FNF Company as indicated by the named discount.

FNF Underwritten Title Company

CTC – Chicago Title company
 CLTC – Commonwealth Land Title Company
 FNTC – Fidelity National Title Company of California
 FNTCCA - Fidelity National Title Company of California
 TICOR – Ticor Title Company of California
 LTC – Lawyer's Title Company
 SLTC – ServiceLink Title Company

Underwritten by FNF Underwriters

CTIC – Chicago Title Insurance Company
 CLTIC - Commonwealth Land Title Insurance Company
 FNTIC – Fidelity National Title Insurance Company
 FNTIC - Fidelity National Title Insurance Company
 CTIC – Chicago Title Insurance Company
 CLTIC – Commonwealth Land Title Insurance Company
 CTIC – Chicago Title Insurance Company

Available Discounts

DISASTER LOANS (CTIC, CLTIC, FNTIC)

The charge for a Lender's Policy (Standard or Extended coverage) covering the financing or refinancing by an owner of record, within twenty-four (24) months of the date of a declaration of a disaster area by the government of the United States or the State of California on any land located in said area, which was partially or totally destroyed in the disaster, will be fifty percent (50%) of the appropriate title insurance rate.

CHURCHES OR CHARITABLE NON-PROFIT ORGANIZATIONS (CTIC, FNTIC)

On properties used as a church or for charitable purposes within the scope of the normal activities of such entities, provided said charge is normally the church's obligation the charge for an owner's policy shall be fifty percent (50%) to seventy percent (70%) of the appropriate title insurance rate, depending on the type of coverage selected. The charge for a lender's policy shall be forty (40%) to fifty percent (50%) of the appropriate title insurance rate, depending on the type of coverage selected.

FIDELITY NATIONAL FINANCIAL, INC. PRIVACY NOTICE

Effective April 9, 2020

Fidelity National Financial, Inc. and its majority-owned subsidiary companies (collectively, “FNF,” “our,” or “we”) respect and are committed to protecting your privacy. This Privacy Notice explains how we collect, use, and protect personal information, when and to whom we disclose such information, and the choices you have about the use and disclosure of that information.

A limited number of FNF subsidiaries have their own privacy notices. If a subsidiary has its own privacy notice, the privacy notice will be available on the subsidiary’s website and this Privacy Notice does not apply.

Collection of Personal Information

FNF may collect the following categories of Personal Information:

- contact information (e.g., name, address, phone number, email address);
- demographic information (e.g., date of birth, gender, marital status);
- identity information (e.g. Social Security Number, driver’s license, passport, or other government ID number);
- financial account information (e.g. loan or bank account information); and
- other personal information necessary to provide products or services to you.

We may collect Personal Information about you from:

- information we receive from you or your agent;
- information about your transactions with FNF, our affiliates, or others; and
- information we receive from consumer reporting agencies and/or governmental entities, either directly from these entities or through others.

Collection of Browsing Information

FNF automatically collects the following types of Browsing Information when you access an FNF website, online service, or application (each an “FNF Website”) from your Internet browser, computer, and/or device:

- Internet Protocol (IP) address and operating system;
- browser version, language, and type;
- domain name system requests; and
- browsing history on the FNF Website, such as date and time of your visit to the FNF Website and visits to the pages within the FNF Website.

Like most websites, our servers automatically log each visitor to the FNF Website and may collect the Browsing Information described above. We use Browsing Information for system administration, troubleshooting, fraud investigation, and to improve our websites. Browsing Information generally does not reveal anything personal about you, though if you have created a user account for an FNF Website and are logged into that account, the FNF Website may be able to link certain browsing activity to your user account.

Other Online Specifics

Cookies. When you visit an FNF Website, a “cookie” may be sent to your computer. A cookie is a small piece of data that is sent to your Internet browser from a web server and stored on your computer’s hard drive. Information gathered using cookies helps us improve your user experience. For example, a cookie can help the website load properly or can customize the display page based on your browser type and user preferences. You can choose whether or not to accept cookies by changing your Internet browser settings. Be aware that doing so may impair or limit some functionality of the FNF Website.

Web Beacons. We use web beacons to determine when and how many times a page has been viewed. This information is used to improve our websites.

Do Not Track. Currently our FNF Websites do not respond to “Do Not Track” features enabled through your browser.

Links to Other Sites. FNF Websites may contain links to unaffiliated third-party websites. FNF is not responsible for the privacy practices or content of those websites. We recommend that you read the privacy policy of every website you visit.

Use of Personal Information

FNF uses Personal Information for three main purposes:

- To provide products and services to you or in connection with a transaction involving you.
- To improve our products and services.
- To communicate with you about our, our affiliates’, and others’ products and services, jointly or independently.

When Information Is Disclosed

We may disclose your Personal Information and Browsing Information in the following circumstances:

- to enable us to detect or prevent criminal activity, fraud, material misrepresentation, or nondisclosure;
- to nonaffiliated service providers who provide or perform services or functions on our behalf and who agree to use the information only to provide such services or functions;

- to nonaffiliated third party service providers with whom we perform joint marketing, pursuant to an agreement with them to jointly market financial products or services to you;
- to law enforcement or authorities in connection with an investigation, or in response to a subpoena or court order; or
- in the good-faith belief that such disclosure is necessary to comply with legal process or applicable laws, or to protect the rights, property, or safety of FNF, its customers, or the public.

The law does not require your prior authorization and does not allow you to restrict the disclosures described above. Additionally, we may disclose your information to third parties for whom you have given us authorization or consent to make such disclosure. We do not otherwise share your Personal Information or Browsing Information with nonaffiliated third parties, except as required or permitted by law. We may share your Personal Information with affiliates (other companies owned by FNF) to directly market to you. Please see "Choices with Your Information" to learn how to restrict that sharing.

We reserve the right to transfer your Personal Information, Browsing Information, and any other information, in connection with the sale or other disposition of all or part of the FNF business and/or assets, or in the event of bankruptcy, reorganization, insolvency, receivership, or an assignment for the benefit of creditors. By submitting Personal Information and/or Browsing Information to FNF, you expressly agree and consent to the use and/or transfer of the foregoing information in connection with any of the above described proceedings.

Security of Your Information

We maintain physical, electronic, and procedural safeguards to protect your Personal Information.

Choices With Your Information

If you do not want FNF to share your information among our affiliates to directly market to you, you may send an "opt out" request by email, phone, or physical mail as directed at the end of this Privacy Notice. We do not share your Personal Information with nonaffiliates for their use to direct market to you without your consent.

Whether you submit Personal Information or Browsing Information to FNF is entirely up to you. If you decide not to submit Personal Information or Browsing Information, FNF may not be able to provide certain services or products to you.

For California Residents: We will not share your Personal Information or Browsing Information with nonaffiliated third parties, except as permitted by California law. For additional information about your California privacy rights, please visit the "California Privacy" link on our website (<https://fnf.com/pages/californiaprivacy.aspx>) or call (888) 413-1748.

For Nevada Residents: You may be placed on our internal Do Not Call List by calling (888) 934-3354 or by contacting us via the information set forth at the end of this Privacy Notice. Nevada law requires that we also provide you with the following contact information: Bureau of Consumer Protection, Office of the Nevada Attorney General, 555 E. Washington St., Suite 3900, Las Vegas, NV 89101; Phone number: (702) 486-3132; email: BCPINFO@ag.state.nv.us.

For Oregon Residents: We will not share your Personal Information or Browsing Information with nonaffiliated third parties for marketing purposes, except after you have been informed by us of such sharing and had an opportunity to indicate that you do not want a disclosure made for marketing purposes.

For Vermont Residents: We will not disclose information about your creditworthiness to our affiliates and will not disclose your personal information, financial information, credit report, or health information to nonaffiliated third parties to market to you, other than as permitted by Vermont law, unless you authorize us to make those disclosures.

Information From Children

The FNF Websites are not intended or designed to attract persons under the age of eighteen (18). We do not collect Personal Information from any person that we know to be under the age of thirteen (13) without permission from a parent or guardian.

International Users

FNF's headquarters is located within the United States. If you reside outside the United States and choose to provide Personal Information or Browsing Information to us, please note that we may transfer that information outside of your country of residence. By providing FNF with your Personal Information and/or Browsing Information, you consent to our collection, transfer, and use of such information in accordance with this Privacy Notice.

FNF Website Services for Mortgage Loans

Certain FNF companies provide services to mortgage loan servicers, including hosting websites that collect customer information on behalf of mortgage loan servicers (the "Service Websites"). The Service Websites may contain links to both this Privacy Notice and the mortgage loan servicer or lender's privacy notice. The sections of this Privacy Notice titled When Information is Disclosed, Choices with Your Information, and Accessing and Correcting Information do not apply to the Service Websites. The mortgage loan servicer or lender's privacy notice governs use, disclosure, and access to your Personal Information. FNF does not share Personal Information collected through the Service Websites, except as required or authorized by contract with the mortgage loan servicer or lender, or as required by law or in the good-faith belief that such disclosure is necessary: to comply with a legal process or applicable law, to enforce this Privacy Notice, or to protect the rights, property, or safety of FNF or the public.

Your Consent To This Privacy Notice; Notice Changes; Use of Comments or Feedback

By submitting Personal Information and/or Browsing Information to FNF, you consent to the collection and use of the information in accordance with this Privacy Notice. We may change this Privacy Notice at any time. The Privacy Notice's effective date will show the last date changes were made. If you provide information to us following any change of the Privacy Notice, that signifies your assent to and acceptance of the changes to the Privacy Notice. We may use comments or feedback that you submit to us in any manner without notice or compensation to you.

Accessing and Correcting Information; Contact Us

If you have questions, would like to correct your Personal Information, or want to opt-out of information sharing for affiliate marketing, send your requests to privacy@fnf.com, by phone to (888) 934-3354, or by mail to:

Fidelity National Financial, Inc.
601 Riverside Avenue
Jacksonville, Florida 32204
Attn: Chief Privacy Officer

ATTACHMENT ONE (Revised 05-06-16)

CALIFORNIA LAND TITLE ASSOCIATION STANDARD COVERAGE POLICY – 1990

EXCLUSIONS FROM COVERAGE

The following matters are expressly excluded from the coverage of this policy and the Company will not pay loss or damage, costs, attorneys' fees or expenses which arise by reason of:

1. (a) Any law, ordinance or governmental regulation (including but not limited to building or zoning laws, ordinances, or regulations) restricting, regulating, prohibiting or relating (i) the occupancy, use, or enjoyment of the land; (ii) the character, dimensions or location of any improvement now or hereafter erected on the land; (iii) a separation in ownership or a change in the dimensions or area of the land or any parcel of which the land is or was a part; or (iv) environmental protection, or the effect of any violation of these laws, ordinances or governmental regulations, except to the extent that a notice of the enforcement thereof or a notice of a defect, lien, or encumbrance resulting from a violation or alleged violation affecting the land has been recorded in the public records at Date of Policy.
- (b) Any governmental police power not excluded by (a) above, except to the extent that a notice of the exercise thereof or notice of a defect, lien or encumbrance resulting from a violation or alleged violation affecting the land has been recorded in the public records at Date of Policy.
2. Rights of eminent domain unless notice of the exercise thereof has been recorded in the public records at Date of Policy, but not excluding from coverage any taking which has occurred prior to Date of Policy which would be binding on the rights of a purchaser for value without knowledge.
3. Defects, liens, encumbrances, adverse claims or other matters:
 - (a) whether or not recorded in the public records at Date of Policy, but created, suffered, assumed or agreed to by the insured claimant;
 - (b) not known to the Company, not recorded in the public records at Date of Policy, but known to the insured claimant and not disclosed in writing to the Company by the insured claimant prior to the date the insured claimant became an insured under this policy;
 - (c) resulting in no loss or damage to the insured claimant;
 - (d) attaching or created subsequent to Date of Policy; or
 - (e) resulting in loss or damage which would not have been sustained if the insured claimant had paid value for the insured mortgage or for the estate or interest insured by this policy.
4. Unenforceability of the lien of the insured mortgage because of the inability or failure of the insured at Date of Policy, or the inability or failure of any subsequent owner of the indebtedness, to comply with the applicable doing business laws of the state in which the land is situated.
5. Invalidity or unenforceability of the lien of the insured mortgage, or claim thereof, which arises out of the transaction evidenced by the insured mortgage and is based upon usury or any consumer credit protection or truth in lending law.
6. Any claim, which arises out of the transaction vesting in the insured the estate of interest insured by this policy or the transaction creating the interest of the insured lender, by reason of the operation of federal bankruptcy, state insolvency or similar creditors' rights laws.

EXCEPTIONS FROM COVERAGE - SCHEDULE B, PART I

This policy does not insure against loss or damage (and the Company will not pay costs, attorneys' fees or expenses) which arise by reason of:

1. Taxes or assessments which are not shown as existing liens by the records of any taxing authority that levies taxes or assessments on real property or by the public records.
Proceedings by a public agency which may result in taxes or assessments, or notices of such proceedings, whether or not shown by the records of such agency or by the public records.
2. Any facts, rights, interests, or claims which are not shown by the public records but which could be ascertained by an inspection of the land or which may be asserted by persons in possession thereof.
3. Easements, liens or encumbrances, or claims thereof, not shown by the public records.
4. Discrepancies, conflicts in boundary lines, shortage in area, encroachments, or any other facts which a correct survey would disclose, and which are not shown by the public records.
5. (a) Unpatented mining claims; (b) reservations or exceptions in patents or in Acts authorizing the issuance thereof; (c) water rights, claims or title to water, whether or not the matters excepted under (a), (b) or (c) are shown by the public records.
6. Any lien or right to a lien for services, labor or material not shown by the public records.

CLTA HOMEOWNER'S POLICY OF TITLE INSURANCE (12-02-13) ALTA HOMEOWNER'S POLICY OF TITLE INSURANCE

EXCLUSIONS

In addition to the Exceptions in Schedule B, You are not insured against loss, costs, attorneys' fees, and expenses resulting from:

1. Governmental police power, and the existence or violation of those portions of any law or government regulation concerning:
 - a. building;
 - b. zoning;
 - c. land use;
 - d. improvements on the Land;
 - e. land division; and
 - f. environmental protection.This Exclusion does not limit the coverage described in Covered Risk 8.a., 14, 15, 16, 18, 19, 20, 23 or 27.
2. The failure of Your existing structures, or any part of them, to be constructed in accordance with applicable building codes. This Exclusion does not limit the coverage described in Covered Risk 14 or 15.
3. The right to take the Land by condemning it. This Exclusion does not limit the coverage described in Covered Risk 17.
4. Risks:
 - a. that are created, allowed, or agreed to by You, whether or not they are recorded in the Public Records;
 - b. that are Known to You at the Policy Date, but not to Us, unless they are recorded in the Public Records at the Policy Date;

- c. that result in no loss to You; or
 - d. that first occur after the Policy Date - this does not limit the coverage described in Covered Risk 7, 8.e., 25, 26, 27 or 28.
5. Failure to pay value for Your Title.
 6. Lack of a right:
 - a. to any land outside the area specifically described and referred to in paragraph 3 of Schedule A; and
 - b. in streets, alleys, or waterways that touch the Land.
 This Exclusion does not limit the coverage described in Covered Risk 11 or 21.
 7. The transfer of the Title to You is invalid as a preferential transfer or as a fraudulent transfer or conveyance under federal bankruptcy, state insolvency, or similar creditors' rights laws.
 8. Contamination, explosion, fire, flooding, vibration, fracturing, earthquake, or subsidence.
 9. Negligence by a person or an Entity exercising a right to extract or develop minerals, water, or any other substances.

LIMITATIONS ON COVERED RISKS

Your insurance for the following Covered Risks is limited on the Owner's Coverage Statement as follows:

- For Covered Risk 16, 18, 19, and 21 Your Deductible Amount and Our Maximum Dollar Limit of Liability shown in Schedule A.

The deductible amounts and maximum dollar limits shown on Schedule A are as follows:

	Your Deductible Amount	Our Maximum Dollar Limit of Liability
Covered Risk 16:	1.00% of Policy Amount Shown in Schedule A or \$2,500.00 (whichever is less)	\$ 10,000.00
Covered Risk 18:	1.00% of Policy Amount Shown in Schedule A or \$5,000.00 (whichever is less)	\$ 25,000.00
Covered Risk 19:	1.00% of Policy Amount Shown in Schedule A or \$5,000.00 (whichever is less)	\$ 25,000.00
Covered Risk 21:	1.00% of Policy Amount Shown in Schedule A or \$2,500.00 (whichever is less)	\$ 5,000.00

2006 ALTA LOAN POLICY (06-17-06)

EXCLUSIONS FROM COVERAGE

The following matters are expressly excluded from the coverage of this policy, and the Company will not pay loss or damage, costs, attorneys' fees, or expenses that arise by reason of:

1. (a) Any law, ordinance, permit, or governmental regulation (including those relating to building and zoning) restricting, regulating, prohibiting, or relating to
 - (i) the occupancy, use, or enjoyment of the Land;
 - (ii) the character, dimensions, or location of any improvement erected on the Land;
 - (iii) the subdivision of land; or
 - (iv) environmental protection;
 or the effect of any violation of these laws, ordinances, or governmental regulations. This Exclusion 1(a) does not modify or limit the coverage provided under Covered Risk 5.
- (b) Any governmental police power. This Exclusion 1(b) does not modify or limit the coverage provided under Covered Risk 6.
2. Rights of eminent domain. This Exclusion does not modify or limit the coverage provided under Covered Risk 7 or 8.
3. Defects, liens, encumbrances, adverse claims, or other matters
 - (a) created, suffered, assumed, or agreed to by the Insured Claimant;
 - (b) not Known to the Company, not recorded in the Public Records at Date of Policy, but Known to the Insured Claimant and not disclosed in writing to the Company by the Insured Claimant prior to the date the Insured Claimant became an Insured under this policy;
 - (c) resulting in no loss or damage to the Insured Claimant;
 - (d) attaching or created subsequent to Date of Policy (however, this does not modify or limit the coverage provided under Covered Risk 11, 13 or 14); or
 - (e) resulting in loss or damage that would not have been sustained if the Insured Claimant had paid value for the Insured Mortgage.
4. Unenforceability of the lien of the Insured Mortgage because of the inability or failure of an Insured to comply with applicable doing-business laws of the state where the Land is situated.
5. Invalidity or unenforceability in whole or in part of the lien of the Insured Mortgage that arises out of the transaction evidenced by the Insured Mortgage and is based upon usury or any consumer credit protection or truth-in-lending law.
6. Any claim, by reason of the operation of federal bankruptcy, state insolvency, or similar creditors' rights laws, that the transaction creating the lien of the Insured Mortgage, is
 - (a) a fraudulent conveyance or fraudulent transfer, or
 - (b) a preferential transfer for any reason not stated in Covered Risk 13(b) of this policy.
7. Any lien on the Title for real estate taxes or assessments imposed by governmental authority and created or attaching between Date of Policy and the date of recording of the Insured Mortgage in the Public Records. This Exclusion does not modify or limit the coverage provided under Covered Risk 11(b).

The above policy form may be issued to afford either Standard Coverage or Extended Coverage. In addition to the above Exclusions from Coverage, the Exceptions from Coverage in a Standard Coverage policy will also include the following Exceptions from Coverage:

EXCEPTIONS FROM COVERAGE

{Except as provided in Schedule B - Part II, {t{or T}his policy does not insure against loss or damage, and the Company will not pay costs, attorneys' fees or expenses, that arise by reason of:

{PART I

{The above policy form may be issued to afford either Standard Coverage or Extended Coverage. In addition to the above Exclusions from Coverage, the Exceptions from Coverage in a Standard Coverage policy will also include the following Exceptions from Coverage:

1. (a) Taxes or assessments that are not shown as existing liens by the records of any taxing authority that levies taxes or assessments on real property or by the Public Records; (b) proceedings by a public agency that may result in taxes or assessments, or notices of such proceedings, whether or not shown by the records of such agency or by the Public Records.
2. Any facts, rights, interests, or claims that are not shown by the Public Records but that could be ascertained by an inspection of the Land or that may be asserted by persons in possession of the Land.
3. Easements, liens or encumbrances, or claims thereof, not shown by the Public Records.
4. Any encroachment, encumbrance, violation, variation, or adverse circumstance affecting the Title that would be disclosed by an accurate and complete land survey of the Land and not shown by the Public Records.
5. (a) Unpatented mining claims; (b) reservations or exceptions in patents or in Acts authorizing the issuance thereof; (c) water rights, claims or title to water, whether or not the matters excepted under (a), (b), or (c) are shown by the Public Records.
6. Any lien or right to a lien for services, labor or material not shown by the Public Records.}

PART II

In addition to the matters set forth in Part I of this Schedule, the Title is subject to the following matters, and the Company insures against loss or damage sustained in the event that they are not subordinate to the lien of the Insured Mortgage:}

2006 ALTA OWNER'S POLICY (06-17-06)

EXCLUSIONS FROM COVERAGE

The following matters are expressly excluded from the coverage of this policy, and the Company will not pay loss or damage, costs, attorneys' fees, or expenses that arise by reason of:

1. (a) Any law, ordinance, permit, or governmental regulation (including those relating to building and zoning) restricting, regulating, prohibiting, or relating to
 - (i) the occupancy, use, or enjoyment of the Land;
 - (ii) the character, dimensions, or location of any improvement erected on the Land;
 - (iii) the subdivision of land; or
 - (iv) environmental protection;or the effect of any violation of these laws, ordinances, or governmental regulations. This Exclusion 1(a) does not modify or limit the coverage provided under Covered Risk 5.
- (b) Any governmental police power. This Exclusion 1(b) does not modify or limit the coverage provided under Covered Risk 6.
2. Rights of eminent domain. This Exclusion does not modify or limit the coverage provided under Covered Risk 7 or 8.
3. Defects, liens, encumbrances, adverse claims, or other matters
 - (a) created, suffered, assumed, or agreed to by the Insured Claimant;
 - (b) not known to the Company, not recorded in the Public Records at Date of Policy, but known to the Insured Claimant and not disclosed in writing to the Company by the Insured Claimant prior to the date the Insured Claimant became an Insured under this policy;
 - (c) resulting in no loss or damage to the Insured Claimant;
 - (d) attaching or created subsequent to Date of Policy (however, this does not modify or limit the coverage provided under Covered Risk 9 and 10); or
 - (e) resulting in loss or damage that would not have been sustained if the Insured Claimant had paid value for the Title.
4. Any claim, by reason of the operation of federal bankruptcy, state insolvency, or similar creditors' rights laws, that the transaction vesting the Title as shown in Schedule A, is
 - (a) a fraudulent conveyance or fraudulent transfer; or
 - (b) a preferential transfer for any reason not stated in Covered Risk 9 of this policy.
5. Any lien on the Title for real estate taxes or assessments imposed by governmental authority and created or attaching between Date of Policy and the date of recording of the deed or other instrument of transfer in the Public Records that vests Title as shown in Schedule A.

The above policy form may be issued to afford either Standard Coverage or Extended Coverage. In addition to the above Exclusions from Coverage, the Exceptions from Coverage in a Standard Coverage policy will also include the following Exceptions from Coverage:

EXCEPTIONS FROM COVERAGE

This policy does not insure against loss or damage, and the Company will not pay costs, attorneys' fees or expenses, that arise by reason of:

{The above policy form may be issued to afford either Standard Coverage or Extended Coverage. In addition to the above Exclusions from Coverage, the Exceptions from Coverage in a Standard Coverage policy will also include the following Exceptions from Coverage:

1. (a) Taxes or assessments that are not shown as existing liens by the records of any taxing authority that levies taxes or assessments on real property or by the Public Records; (b) proceedings by a public agency that may result in taxes or assessments, or notices of such proceedings, whether or not shown by the records of such agency or by the Public Records.
2. Any facts, rights, interests, or claims that are not shown in the Public Records but that could be ascertained by an inspection of the Land or that may be asserted by persons in possession of the Land.
3. Easements, liens or encumbrances, or claims thereof, not shown by the Public Records.
4. Any encroachment, encumbrance, violation, variation, or adverse circumstance affecting the Title that would be disclosed by an accurate and complete land survey of the Land and that are not shown by the Public Records.
5. (a) Unpatented mining claims; (b) reservations or exceptions in patents or in Acts authorizing the issuance thereof; (c) water rights, claims or title to water, whether or not the matters excepted under (a), (b), or (c) are shown by the Public Records.
6. Any lien or right to a lien for services, labor or material not shown by the Public Records. }
7. {Variable exceptions such as taxes, easements, CC&R's, etc. shown here.}

ALTA EXPANDED COVERAGE RESIDENTIAL LOAN POLICY – ASSESSMENTS PRIORITY (04-02-15)

EXCLUSIONS FROM COVERAGE

The following matters are expressly excluded from the coverage of this policy and the Company will not pay loss or damage, costs, attorneys' fees or expenses which arise by reason of:

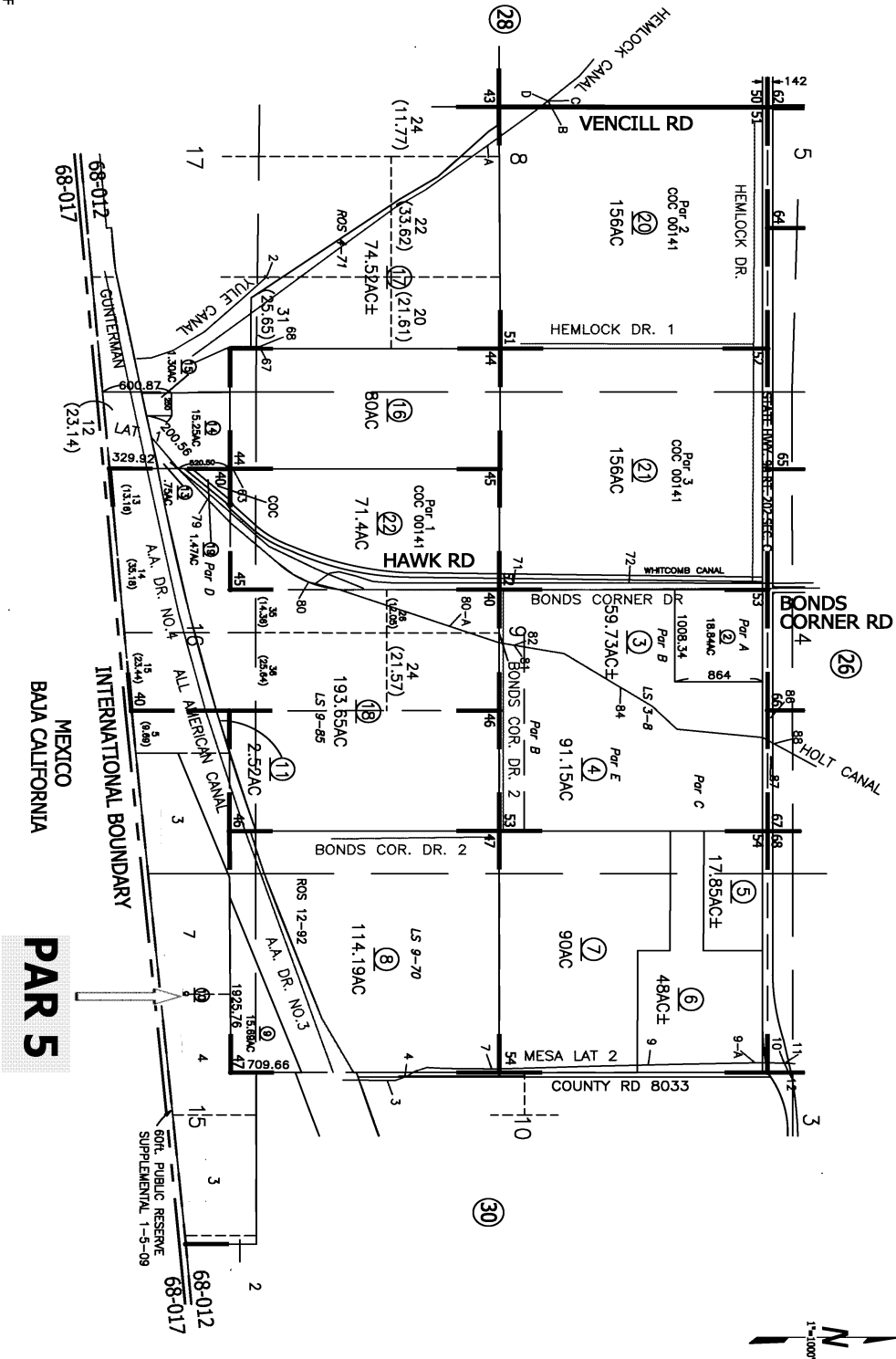
1. (a) Any law, ordinance, permit, or governmental regulation (including those relating to building and zoning) restricting, regulating, prohibiting, or relating to
 - (i) the occupancy, use, or enjoyment of the Land;
 - (ii) the character, dimensions, or location of any improvement erected on the Land;
 - (iii) the subdivision of land; or
 - (iv) environmental protection;or the effect of any violation of these laws, ordinances, or governmental regulations. This Exclusion 1(a) does not modify or limit the coverage provided under Covered Risk 5, 6, 13(c), 13(d), 14 or 16.
- (b) Any governmental police power. This Exclusion 1(b) does not modify or limit the coverage provided under Covered Risk 5, 6, 13(c), 13(d), 14 or 16.
2. Rights of eminent domain. This Exclusion does not modify or limit the coverage provided under Covered Risk 7 or 8.
3. Defects, liens, encumbrances, adverse claims, or other matters
 - (a) created, suffered, assumed, or agreed to by the Insured Claimant;
 - (b) not Known to the Company, not recorded in the Public Records at Date of Policy, but Known to the Insured Claimant and not disclosed in writing to the Company by the Insured Claimant prior to the date the Insured Claimant became an Insured under this policy;
 - (c) resulting in no loss or damage to the Insured Claimant;
 - (d) attaching or created subsequent to Date of Policy (however, this does not modify or limit the coverage provided under Covered Risk 11, 16, 17, 18, 19, 20, 21, 22, 23, 24, 27 or 28); or
 - (e) resulting in loss or damage that would not have been sustained if the Insured Claimant had paid value for the Insured Mortgage.
4. Unenforceability of the lien of the Insured Mortgage because of the inability or failure of an Insured to comply with applicable doing-business laws of the state where the Land is situated.
5. Invalidity or unenforceability in whole or in part of the lien of the Insured Mortgage that arises out of the transaction evidenced by the Insured Mortgage and is based upon usury, or any consumer credit protection or truth-in-lending law. This Exclusion does not modify or limit the coverage provided in Covered Risk 26.
6. Any claim of invalidity, unenforceability or lack of priority of the lien of the Insured Mortgage as to Advances or modifications made after the Insured has Knowledge that the vestee shown in Schedule A is no longer the owner of the estate or interest covered by this policy. This Exclusion does not modify or limit the coverage provided in Covered Risk 11.
7. Any lien on the Title for real estate taxes or assessments imposed by governmental authority and created or attaching subsequent to Date of Policy. This Exclusion does not modify or limit the coverage provided in Covered Risk 11(b) or 25.
8. The failure of the residential structure, or any portion of it, to have been constructed before, on or after Date of Policy in accordance with applicable building codes. This Exclusion does not modify or limit the coverage provided in Covered Risk 5 or 6.
9. Any claim, by reason of the operation of federal bankruptcy, state insolvency, or similar creditors' rights laws, that the transaction creating the lien of the Insured Mortgage, is
 - (a) a fraudulent conveyance or fraudulent transfer, or
 - (b) a preferential transfer for any reason not stated in Covered Risk 27(b) of this policy.
10. Contamination, explosion, fire, flooding, vibration, fracturing, earthquake, or subsidence.
11. Negligence by a person or an Entity exercising a right to extract or develop minerals, water, or any other substances.

This map/plat is being furnished as an aid in locating the herein described Land in relation to adjoining streets, natural boundaries and other land, and is not a survey of the land depicted. Except to the extent a policy of title insurance is expressly modified by endorsement, if any, the Company does not insure dimensions, distances, location of easements, acreage or other matters shown thereon.

TRACT 40,44,45,46,47,51,52,53 & 54
 POR. SEC. 8,9,10,15,16 & 17 T17S R16E

Tax Area Code
 68-012
 68-017

59-29



- 9-9-09 MF
- 8-17-09 MF
- 7-1-04 AR
- 04-26-93 DP
- 01-02-92 RM
- 03-25-80 LJ
- 01-18-78 LS
- From 57-51
- 3-27-12 MF
- 1-14-10 MF

DISCLAIMER:
 THIS IS NOT AN OFFICIAL MAP
 THIS MAP WAS CREATED FOR THE IMPERIAL COUNTY
 ASSESSOR, FOR THE SOLE PURPOSE OF AIDING IN
 THE PERFORMANCE OF THE DUTIES OF THE ASSESSOR.
 ANY ERRORS OR OMISSIONS IN THIS MAP ARE NOT
 THE RESPONSIBILITY OF THE COUNTY OF IMPERIAL
 OR THE ASSESSOR. (REV. & TAX CODE SEC.327)



PAR 5

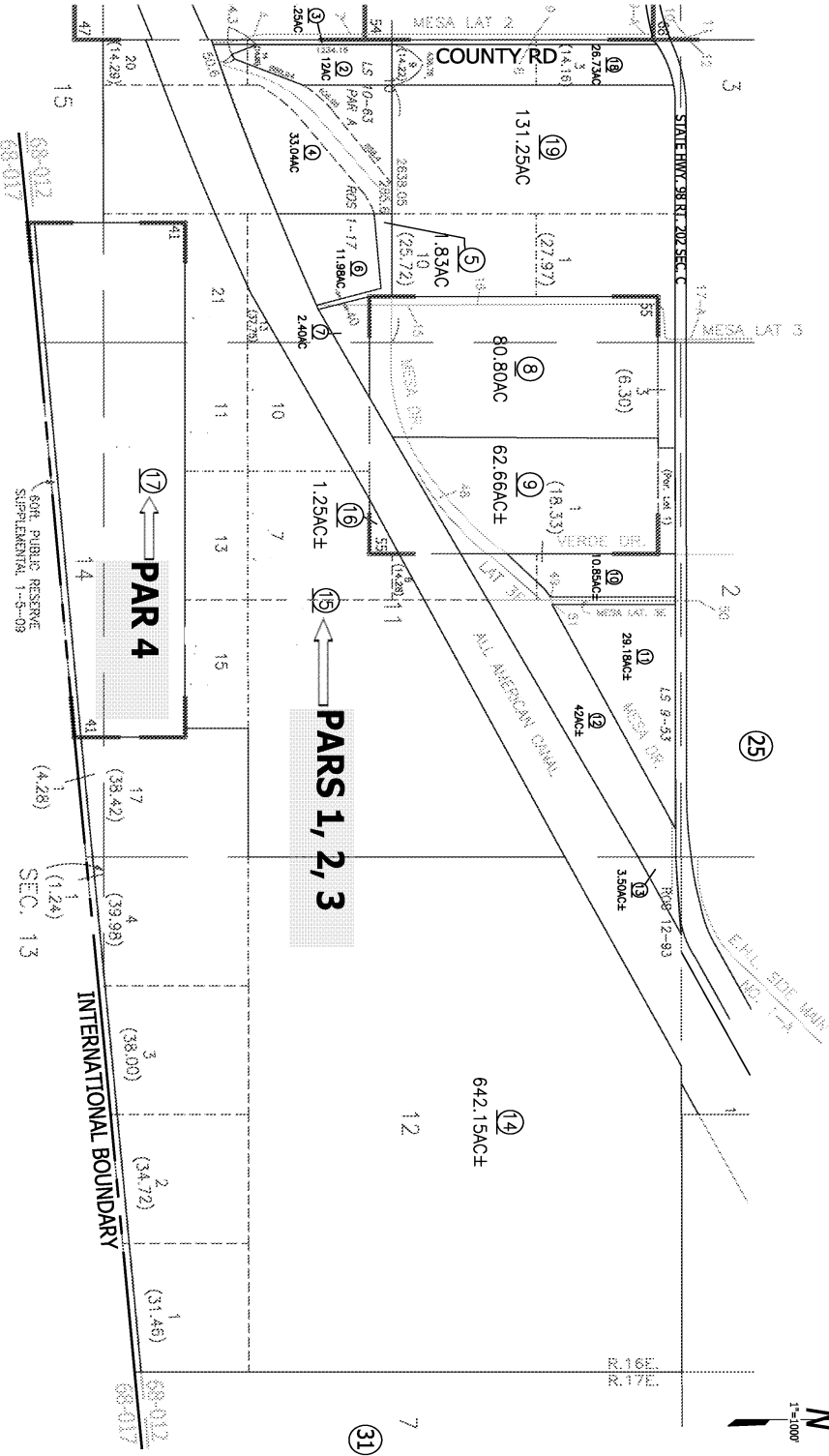
Assessor's Map Bk.59-Pg.29
 County of Imperial, Calif.

This map/plat is being furnished as an aid in locating the herein described Land in relation to adjoining streets, natural boundaries and other land, and is not a survey of the land depicted. Except to the extent a policy of title insurance is expressly modified by endorsement, if any, the Company does not insure dimensions, distances, location of easements, acreage or other matters shown thereon.

TRACT 41 & 55
 SEC. 11 & 12 POR, SEC. 1, 10, 13, 14 & 15
 T.17S, R.16E, S.B.B. & M.

Tax Area Code
 68-012
 68-017

59-30



10-25-10 MF
 1-14-10 MF
 9-05-07 MF
 3-25-80 JJ
 1-18-78 JJ
 From 57-52

DISCLAIMER:
 THIS IS NOT AN OFFICIAL MAP.
 THIS MAP WAS CREATED FOR THE IMPERIAL COUNTY
 ASSESSOR, FOR THE SOLE PURPOSE OF AIDING IN
 THE PERFORMANCE OF THE DUTIES OF THE ASSESSOR.
 ANY ERRORS OR OMISSIONS IN THIS MAP ARE NOT
 THE RESPONSIBILITY OF THE COUNTY OF IMPERIAL
 OR THE ASSESSOR. (REV. & TAX CODE SEC.327)

Date	By	Revision
10-18-52	R.M.	Blow-up & Revision of Bk.57 Pg.44-Portion Sheet 6 of 6 Sheets

MEXICO
 BAJA CALIFORNIA

Assessor's Map Bk.59-Pg.30
 County of Imperial, Calif.

RECORDING REQUESTED BY
Fidelity National Title Company
WHEN RECORDED MAIL TO:
=addressee=

ORDER NO.: 30053824-997-ML6

SPACE ABOVE THIS LINE FOR RECORDER'S USE

CERTIFICATION OF TRUST
California Probate Code Section 18100.5

The undersigned declare(s) under penalty of perjury under the laws of the State of California that the following is true and correct:

1. The Trust known as _____,
executed on _____, is a valid and existing trust.
2. The name(s) of the settlor(s) of the Trust is (are): _____

3. The name(s) of the currently acting trustee(s) is (are): _____

4. The trustee(s) of the Trust have the following powers (initial applicable line(s)):
_____ Power to acquire additional property.
_____ Power to sell and execute deeds.
_____ Power to encumber, and execute deeds of trust.
_____ Other: _____
5. The Trust is (check one): _____ Revocable _____ Irrevocable
The name of the person who may revoke the Trust is: _____
6. The number of trustees who must sign documents in order to exercise the powers of the Trust is (are): _____,
whose name(s) is (are): _____
7. Title to Trust assets is to be taken as follows: _____
8. The Trust has not been revoked, modified or amended in any manner which would cause the representations
contained herein to be incorrect.
9. I (we) am (are) all of the currently acting trustees.
10. I (we) understand that I (we) may be required to provide copies of excerpts from the original Trust documents
which designate the trustees and confer the power to act in the pending transaction.

Dated: _____

(Acknowledgement must be attached)

CERTIFICATE OF ACKNOWLEDGEMENT OF NOTARY PUBLIC

A notary public or other officer completing this certificate verifies only the identity of the individual who signed the document to which this certificate is attached, and not the truthfulness, accuracy, or validity of that document.

STATE OF CALIFORNIA
COUNTY OF

} SS:

On _____ before me,

a Notary Public, personally appeared _____

who proved to me on the basis of satisfactory evidence to be the person(s) whose name(s) is/are subscribed to the within instrument and acknowledged to me that he/she/they executed the same in his/her/their authorized capacity(ies) and that by his/her/their signature(s) on the instrument the person(s), or the entity upon behalf of which the person(s) acted, executed the instrument.

I certify under PENALTY OF PERJURY under the laws of the State of California that the foregoing paragraph is true and correct.

WITNESS my hand and official seal.

Signature _____

CERTIFICATE OF ACKNOWLEDGEMENT OF NOTARY PUBLIC

A notary public or other officer completing this certificate verifies only the identity of the individual who signed the document to which this certificate is attached, and not the truthfulness, accuracy, or validity of that document.

STATE OF CALIFORNIA
COUNTY OF

} SS:

On _____ before me,

a Notary Public, personally appeared _____

who proved to me on the basis of satisfactory evidence to be the person(s) whose name(s) is/are subscribed to the within instrument and acknowledged to me that he/she/they executed the same in his/her/their authorized capacity(ies) and that by his/her/their signature(s) on the instrument the person(s), or the entity upon behalf of which the person(s) acted, executed the instrument.

I certify under PENALTY OF PERJURY under the laws of the State of California that the foregoing paragraph is true and correct.

WITNESS my hand and official seal.

Signature _____

RECORDING REQUESTED BY
Fidelity National Title Company
WHEN RECORDED MAIL TO:
=addressee=

ORDER NO.: **30053824-997-ML6**

SPACE ABOVE THIS LINE FOR RECORDER'S USE

CERTIFICATION OF TRUST
California Probate Code Section 18100.5

The undersigned declare(s) under penalty of perjury under the laws of the State of California that the following is true and correct:

1. The Trust known as _____,
executed on _____, is a valid and existing trust.
2. The name(s) of the settlor(s) of the Trust is (are): _____

3. The name(s) of the currently acting trustee(s) is (are): _____

4. The trustee(s) of the Trust have the following powers (initial applicable line(s)):
_____ Power to acquire additional property.
_____ Power to sell and execute deeds.
_____ Power to encumber, and execute deeds of trust.
_____ Other: _____
5. The Trust is (check one): _____ Revocable _____ Irrevocable
The name of the person who may revoke the Trust is: _____
6. The number of trustees who must sign documents in order to exercise the powers of the Trust is (are): _____,
whose name(s) is (are): _____
7. Title to Trust assets is to be taken as follows: _____
8. The Trust has not been revoked, modified or amended in any manner which would cause the representations
contained herein to be incorrect.
9. I (we) am (are) all of the currently acting trustees.
10. I (we) understand that I (we) may be required to provide copies of excerpts from the original Trust documents
which designate the trustees and confer the power to act in the pending transaction.

Dated: _____

(Acknowledgement must be attached)

CERTIFICATE OF ACKNOWLEDGEMENT OF NOTARY PUBLIC

A notary public or other officer completing this certificate verifies only the identity of the individual who signed the document to which this certificate is attached, and not the truthfulness, accuracy, or validity of that document.

STATE OF CALIFORNIA
COUNTY OF

} SS:

On _____ before me,

a Notary Public, personally appeared _____

who proved to me on the basis of satisfactory evidence to be the person(s) whose name(s) is/are subscribed to the within instrument and acknowledged to me that he/she/they executed the same in his/her/their authorized capacity(ies) and that by his/her/their signature(s) on the instrument the person(s), or the entity upon behalf of which the person(s) acted, executed the instrument.

I certify under PENALTY OF PERJURY under the laws of the State of California that the foregoing paragraph is true and correct.

WITNESS my hand and official seal.

Signature _____

CERTIFICATE OF ACKNOWLEDGEMENT OF NOTARY PUBLIC

A notary public or other officer completing this certificate verifies only the identity of the individual who signed the document to which this certificate is attached, and not the truthfulness, accuracy, or validity of that document.

STATE OF CALIFORNIA
COUNTY OF

} SS:

On _____ before me,

a Notary Public, personally appeared _____

who proved to me on the basis of satisfactory evidence to be the person(s) whose name(s) is/are subscribed to the within instrument and acknowledged to me that he/she/they executed the same in his/her/their authorized capacity(ies) and that by his/her/their signature(s) on the instrument the person(s), or the entity upon behalf of which the person(s) acted, executed the instrument.

I certify under PENALTY OF PERJURY under the laws of the State of California that the foregoing paragraph is true and correct.

WITNESS my hand and official seal.

Signature _____

OWNER'S DECLARATION

Escrow No.: 30053824-997-MAT-ML6
Property Address: APN'S #059-300-015-000, 059-300-017-000 and 059-290-010-000
County of Imperial, CA

The undersigned hereby declares as follows:

- 1. (Fill in the applicable paragraph and strike the other)
 - a. Declarant ("Owner") is the owner or lessee, as the case may be, of certain premises located at APN'S #059-300-015-000, 059-300-017-000 and 059-290-010-000, County of Imperial, CA, further described as follows: See Preliminary Report/Commitment No. for full legal description (the "Land").
 - b. Declarant is the _____ of _____ ("Owner"), which is the owner or lessee, as the case may be, of certain premises located at APN'S #059-300-015-000, 059-300-017-000 and 059-290-010-000, County of Imperial, CA, further described as follows: See Preliminary Report/Commitment No. for full legal description (the "Land").
- 2. (Fill in the applicable paragraph and strike the other)
 - a. During the period of six months immediately preceding the date of this declaration no work has been done, no surveys or architectural or engineering plans have been prepared, and no materials have been furnished in connection with the erection, equipment, repair, protection or removal of any building or other structure on the Land or in connection with the improvement of the Land in any manner whatsoever.
 - b. During the period of six months immediately preceding the date of this declaration certain work has been done and materials furnished in connection with _____ upon the Land in the approximate total sum of \$_____, but no work whatever remains to be done and no materials remain to be furnished to complete the construction in full compliance with the plans and specifications, nor are there any unpaid bills incurred for labor and materials used in making such improvements or repairs upon the Land, or for the services of architects, surveyors or engineers, except as follows: _____, Owner, by the undersigned Declarant, agrees to and does hereby indemnify and hold harmless Fidelity National Title Company against any and all claims arising therefrom.
- 3. Owner has not previously conveyed the Land; is not a debtor in bankruptcy (and if a partnership, the general partner thereof is not a debtor in bankruptcy); and has not received notice of any pending court action affecting the title to the Land.
- 4. Except as shown in the above-referenced Preliminary Report/Commitment, there are no unpaid or unsatisfied mortgages, deeds of trust, Uniform Commercial Code financing statements, regular assessments, special assessments, periodic assessments or any assessment from any source, claims of lien, special assessments, or taxes that constitute a lien against the Land or that affect the Land but have not been recorded in the public records. There are no violations of the covenants, conditions and restrictions as shown in the above-referenced Preliminary Report/Commitment.
- 5. The Land is currently in use as _____; _____ occupy/occupies the Land; and the following are all of the leases or other occupancy rights affecting the Land:

- 6. There are no other persons or entities that assert an ownership interest in the Land, nor are there unrecorded easements, claims of easement, or boundary disputes that affect the Land.
- 7. There are no outstanding options to purchase or rights of first refusal affecting the Land.
- 8. Between the most recent Effective Date of the above-referenced Preliminary Report/Commitment and the date of recording of the Insured Instrument(s), Owner has not taken or allowed, and will not take or allow, any action or inaction to encumber or otherwise affect title to the Land.

This declaration is made with the intention that Fidelity National Title Company (the "Company") and its policy issuing agents will rely upon it in issuing their title insurance policies and endorsements. Owner, by the undersigned Declarant, agrees to indemnify the Company against loss or damage (including attorneys fees, expenses, and costs) incurred by the Company as a result of any untrue statement made herein.

I declare under penalty of perjury that the foregoing is true and correct and that this declaration was executed on _____ at _____.

Signature: _____

APPENDIX H

PC ORIGINAL PKG



780 N. 4th Street
El Centro, CA 92243
(760) 337-1100

**Phase I Environmental Site Assessment (ESA)
User Questionnaire**

- 1) **Environmental liens that are filed or recorded against the *property*.**
Did a search of *recorded land title records* (or judicial records where appropriate) identify any environmental liens filed or recorded against the *property* under federal, tribal, state, or local law?

Not to our knowledge.

- 2) **Activity and use limitations that are in place on the *property* or that have been filed or recorded against the *property*.**
Did a search of *recorded land title records* (or judicial records where appropriate) identify any AULs, such as *engineering controls*, land use restrictions or *institutional controls* that are in place at the property and/or have been filed or recorded against the *property* under federal, tribal, state or local law?

Not to our knowledge.

- 3) **Specialized knowledge or experience of the person seeking to qualify for the LLP.**
Do you have any specialized knowledge or experience related to the *property* or nearby properties? For example, are you involved in the same line of business as the current or former occupants of the *property* or an *adjoining property* so that you would have specialized knowledge of the chemicals and processes used by this type of business?

No.

4) **Relationship of the purchase price to the fair market value of the *property* if it were not contaminated.**

Does the purchase price being paid for this *property* reasonable reflect the fair market value of the *property*? If you conclude that there is a difference, have you considered whether the lower purchase price is because contamination is known or believed to be present at the *property*?

Yes.

5) **Commonly known or *reasonably ascertainable* information about the *property*.**

Are you aware of commonly known or *reasonably ascertainable* information about the *property* that would help the *environmental professional* to identify conditions indicative of releases or threatened releases? For example,

- a. Do you know the past uses of the *property*?

Vacant Land

- b. Do you know of specific chemicals or oils that are present or once were present at the *property*?

None that we know of or suspect.

- c. Do you know of spills or other chemical releases that have taken place at the *property*?

None that we know of or suspect.

- d. Do you know of any environmental cleanups that have taken place at the *property*?

None that we know of or suspect.

6) **The degree of obviousness of the presence or likely presence of contamination at the *property*, and the ability to detect the contamination by appropriate investigation.**

Based on your knowledge and experience related to the *property* are there any *obvious* indicators that point to the presence or likely presence of releases at the *property*?

None that we know of or suspect.

Additional Information

1) Reason why Phase I ESA is required:

Conditional Use Permit for proposed development project.

2) Type of Property:

Commercial
Industrial
Residential
Vacant/Undeveloped
Other Fallowed farmland

Type of Transaction:

Purchase
Financing
Sale
Lease
Other _____

3) Complete and correct address for the property:

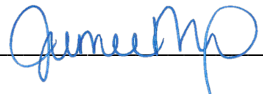
No situs. APN's 059-300-015-000, 059-300-017-000 and 059-290-010-000

4) Are there any existing environmental report, documents, correspondence, etc. available for review?

None.

User Name/Company: Jamie Nagel/Apex Energy Solutions, LLC

Address: 604 Sutter Street, Suite 250
Folsom, CA 95630

User Signature: 

Date: 12/10/2020

5 DD9 B8 ± ' =

PC ORIGINAL PKG



**Steven K. Williams, CEG
Senior Engineering Geologist**

Education

M.S. Geology
University of Utah, 1993
B.S. Geology
University of Utah, 1989

Registration

Registered Geologist
Arizona 3759
California 6975
Certified Engineering Geologist
California 2261

Professional Experience

2000 – Present Project Geologist
GS Lyon Consultants, Inc.
1994 - 2000 Staff Geologist
GS Lyon Consultants, Inc.
1994 Field Geologist
Bureau of Land Management
1991 - 1992 Exploration Geologist
Kennecott Corporation

Summary of Experience

Mr. Williams has performed geotechnical investigations in southern California and southwestern Arizona. His field experience includes logging of soil borings and exploratory trenches, collection and documentation of soil samples, collection of field geotechnical data, and monitoring pile driving operations. Mr. Williams is also responsible for preparing computer generated data and figures, drafting and subsequent writing of geotechnical reports for a variety of projects including road improvements, fault studies, liquefaction potential evaluation, foundation preparation, seepage studies, structural distress, and soil investigations. He has performed geotechnical, geologic, and environmental studies for a wide variety of projects including correctional facilities, water and wastewater facilities, schools, residential subdivisions, commercial developments, and landfills throughout southern California and southwestern Arizona.

Mr. Williams also performs Phase I Environmental Site Assessments throughout the Imperial and Coachella Valleys. The scope of work for these projects typically include a site reconnaissance, review of government records pertaining to previous site uses, and preparation of a report identifying potential environmental risks.

He also conducts investigations for the potential of asbestos-containing materials and lead-based paint in old building projects and potential for soil contamination by hydrocarbons, pesticides, and other hazardous materials.

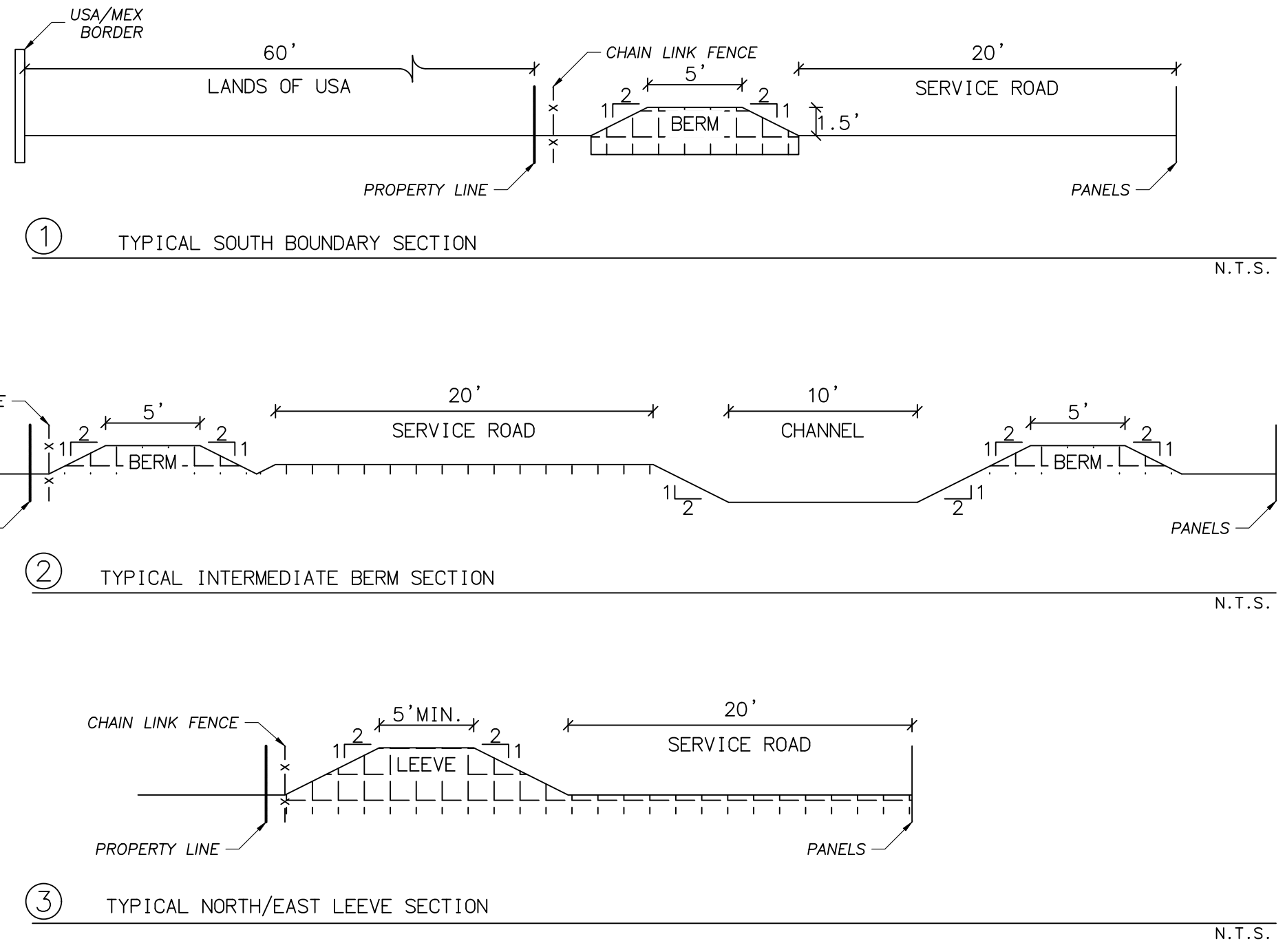
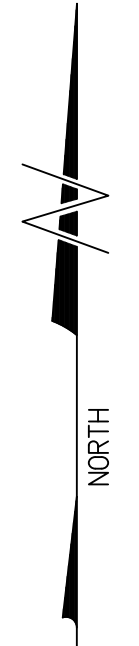
Professional Affiliations

Geological Society of America, Member

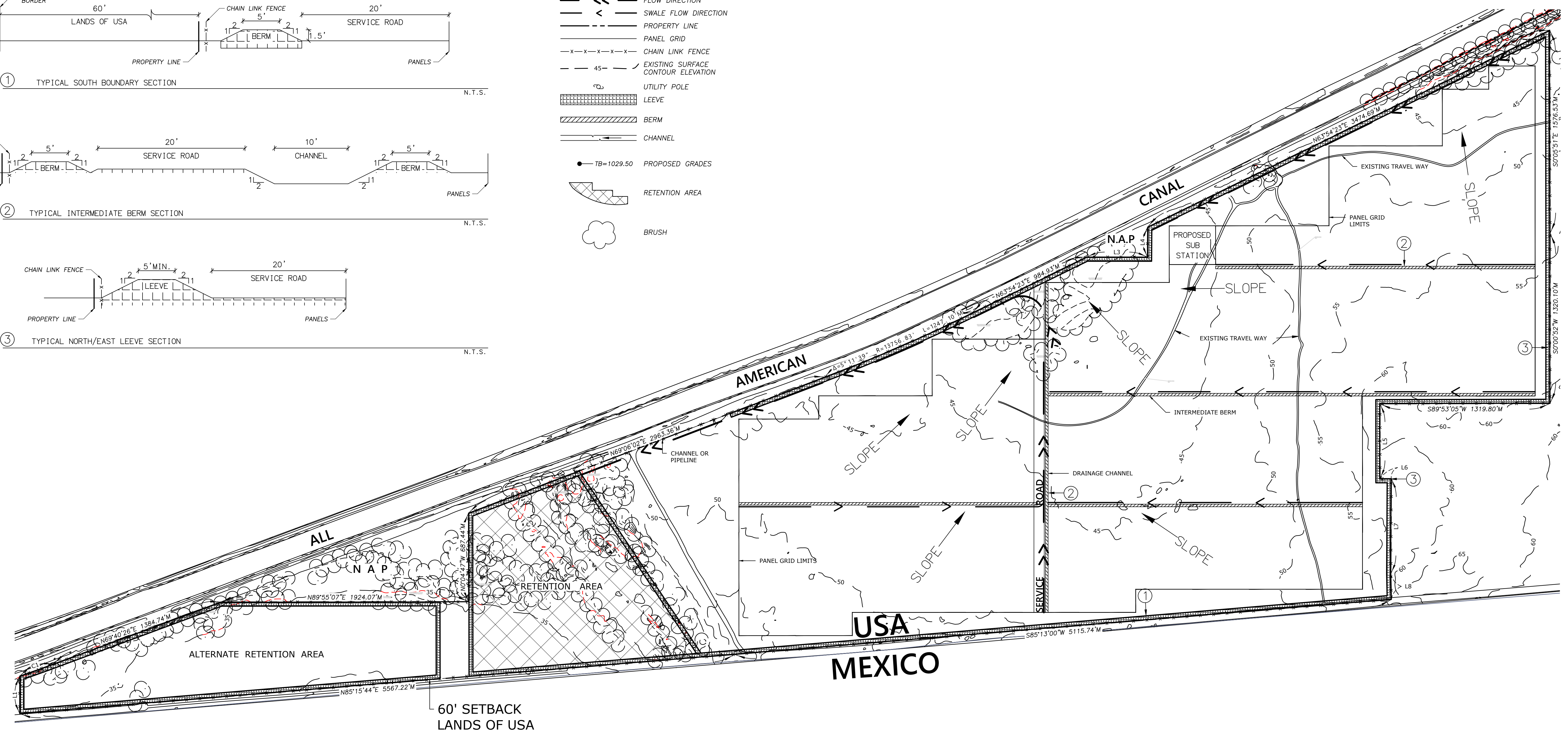
Selected Project Experience

- **El Centro Seniors Apartments, El Centro, CA**
Performed Phase I and Phase II environmental site assessments for apartment complex at old school district office site with underground storage tanks.
- **Central Main Canal Seepage Study, Imperial, CA**
Conducted 6-month groundwater seepage study for Imperial Irrigation District to evaluate high groundwater levels in Sandalwood Glen Subdivision
- **Gateway to the Americas, Calexico, CA**
Conducted Phase I ESA, geologic hazards study and geotechnical investigation including liquefaction evaluation for 1,700 acre development associated with new Port of Entry east of Calexico
- **El Centro Magistrate Court, El Centro, CA**
Conducted geotechnical investigation and Phase I ESA for new Federal Magistrate Court building at site with soft soil conditions requiring foundation settlement analysis
- **El Centro Regional Medical Center, El Centro, CA**
Conducted Phase I ESA and geotechnical investigation for 50,000 sf, 2-story addition to the medical center's emergency room, operating rooms, and recovery rooms.
- **Brawley Union High School, Brawley, CA**
Conducted Phase II investigation for PCB and lead contamination of surficial soil and hydrocarbon contamination of subsurface soil of a property proposed for purchase.
- **EW Corporation Site, Westmorland, CA**
Conducted Phase II investigation for hydrocarbon contamination of subsurface soil of a service station site with leaking underground storage tanks prior to property purchase
- **Various Apartment Complexes, Imperial County, CA**
Conducted Phase I environmental investigation at numerous proposed apartment complex site within the Imperial Valley
- **Oasis Elementary School, Mecca, CA**
Conducted PEA environmental investigation for the new Oasis Elementary School prior to construction of school

PRELIMINARY GRADING PLAN



- LEGEND**
- << — FLOW DIRECTION
 - < — SWALE FLOW DIRECTION
 - - - - - PROPERTY LINE
 - - - - - PANEL GRID
 - x - x - x - CHAIN LINK FENCE
 - - - 45 - - EXISTING SURFACE CONTOUR ELEVATION
 - UTILITY POLE
 - ▨ LEEVE
 - ▨ BERM
 - CHANNELED — CHANNEL
 - TB=1029.50 PROPOSED GRADES
 - ☁ RETENTION AREA
 - ☁ BRUSH



VERTICAL BENCHMARK
 NGS STATION: BR 3 16 A NGS PID: DB0416
 BENCHMARK ELEVATION= 50.78'
 NGS BENCHMARK LOCATION:
 FROM THE INTERSECTION OF STATE HWY 115 AND U.S. 80 IN HOLTVILLE PROCEED SOUTH ABOUT 7 MILES TO THE INTERSECTION OF STATE HIGHWAYS 115 AND 98, KNOWN AS BONDS CORNER, THEN PROCEED EAST ON HIGHWAY 98 3.2 MILES. THE MARK IS LOCATED APPROXIMATELY 400 FEET SOUTH OF THE HIGHWAY AND IS SET ON THE CENTERLINE OF THE EAST WHEEL GUARD OF THE BRIDGE AT THE EAST HIGHLINE CHECK AT THE POINT WHERE THE EAST HIGHLINE CANAL IS DIVERTED FROM THE ALL AMERICAN CANAL. SECTION 1 T17S, R16E.

INCREMENTAL INCREASE IN STORM WATER VOLUMES
 NUMBER OF ESTIMATED PANEL FRAME FOUNDATIONS: 85 BLOCKS X 3200 PANELS = 272,800 FOUNDATIONS.
 ASSUME 0.25 S.F. PER FOUNDATION: TOTAL FOUNDATION AREA = 0.25(272,800) = 68,000 S.F.
 AREA OF FOUNDATIONS IN ELECTRICAL SUBSTATION = 10,000 S.F.
 TOTAL INCREMENTAL RUNOFF = 0.25 FT. (68,000 S.F. + 10,000 S.F.) = 19,500 CU. FT.
 i = 3" STORM (100 YEAR)
 A = 520 ACRES (SOLAR FARM AREA)
 C = 1.0 PER COUNTY STANDARD
 Q = CIA
 Q = 1.0(0.25) 520AC
 Q = 130 AC FT. = 5,662,800 C.F. + 19,500 C.F. = 5,682,300 C.F.
RETENTION AREA
 WEST SIDE = 800' AVERAGE WIDTH X 7.9' AVERAGE DEPTH X 900' LENGTH = 5,688,000 C.F. > 5,682,300 C.F. ∴ OK

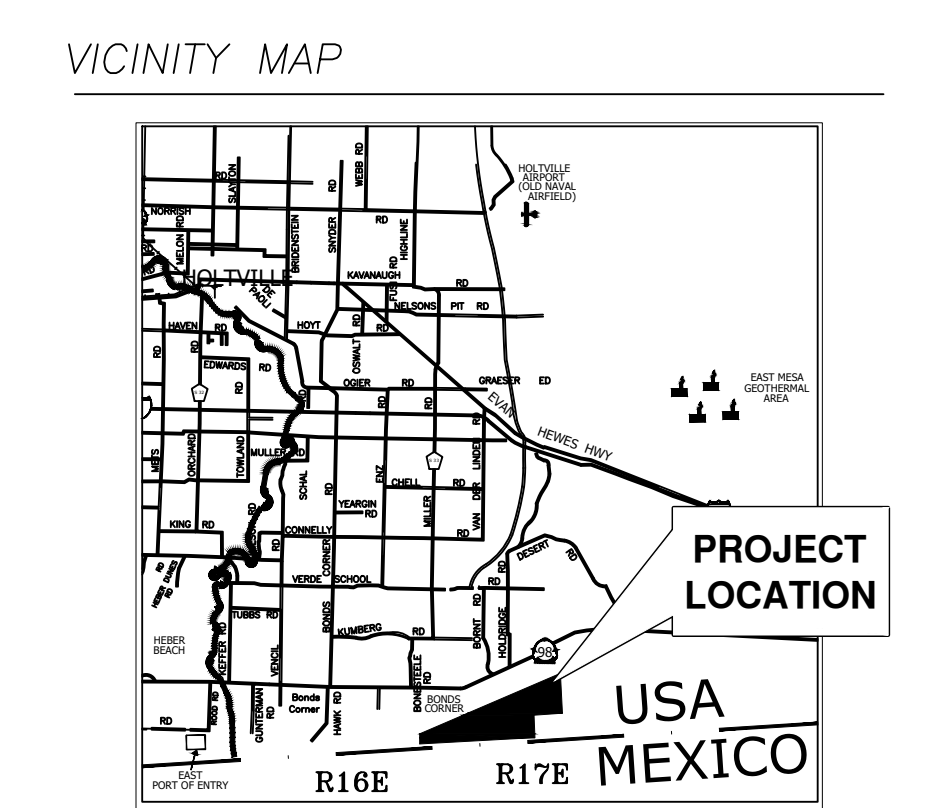
- NOTES**
- THE HORIZONTAL AND VERTICAL CONTROL WAS PERFORMED BY PRECISION ENGINEERING AND SURVEYING IN OCTOBER, 2020.
 - THE AERIAL PHOTOGRAPHY WAS PERFORMED BY COOPER AERIAL ON OCTOBER 16, 2020
 - SOLAR FARM PANEL AREA IS 324 ACRES.
 - NO ADJUSTMENTS HAVE BEEN MADE TO THE PANEL LAYOUT OR LEEVE LOCATION FOR ENVIRONMENTAL ISSUES. THIS WOULD INCLUDE WETLANDS, RIPARIAN HABITAT OR CULTURAL LOCATIONS. MINOR MODIFICATIONS MAY BE REQUIRED.

FEMA NOTE
 AS SHOWN ON THIS SURVEY, PART OF THE SUBJECT LAND IS LOCATED IN A 100-YEAR FLOOD PLAIN OR IN AN IDENTIFIED "FLOOD PRONE AREA", AS DEFINED PURSUANT TO THE FLOOD DISASTER PROTECTION ACT OF 1973, AS AMENDED, AS REFLECTED BY FLOOD INSURANCE RATE MAP PANEL #06025C2125C DATED SEPTEMBER 26, 2008. THE SUBJECT PARCEL IS LOCATED IN ZONE "X."

GRADING / DRAINAGE METHODOLOGY
 THE DOYLE RANCH SOLAR FARM PROJECT IS APPROXIMATELY 521 GROSS ACRES SOUTH OF THE ALL AMERICAN CANAL AND NORTH OF THE MEXICO BOUNDARY, OF WHICH 510 ACRES WILL BE DEVELOPED. THE DEVELOPED AREA WILL BE SURROUNDED BY A LEEVE THAT WILL PROTECT THE PANELS. A LEEVE DESIGNED FOR A 100 YEAR EVENT WILL DIVERT THE STORMWATER AROUND THE SITE TO FLOW TO THE RETENTION AREA.
 THE DEVELOPED PANEL AREA WILL HAVE RETENTION AREAS OUTSIDE THE ALL AMERICAN CANAL RIGHT OF WAY ON THE NORTH SIDE OF THE PROJECT. THE RETENTION AREA SHOULD BE DESIGNED MINIMAL FOR THE INCREMENTAL INCREASE IN STORMWATER CAUSED BY THE PANEL SUPPORTS.
 ALL THE STORMWATER IS PROPOSED TO REMAIN ON SITE.

LINE TABLE			
#	BEARINGS	LENGTH	REF.
L1	N0°01'40"E	291.80'	M
L2	N0°12'49"W	631.85'	M
L3	S89°58'41"E	473.41'	M
L4	N0°21'06"E	232.74'	M
L5	S0°01'05"E	581.39'	M
L6	N89°56'50"E	88.08'	M
L7	N0°19'18"E	737.95'	M
L8	N0°11'59"W	199.78'	M

CURVE TABLE				
#	DELTA	RADIUS	LENGTH	REF.
C1	01°21'59"	11659.20'	278.06'	M



DOYLE
 PORTION OF SECTIONS 10, 11 & 12, T17S-R16E S.B.M.



GRADING PLAN FOR APEX ENERGY: SES 4		SHEET No.
LOCATION: PORTIONS OF SECTIONS 10, 11 AND 12 IN T.17S.-R.16E. S.B.M.		1
Precision Engineering & Surveying, Inc. P.O. Box 2216 El Centro, CA 92244 Telephone: (760) 353-2684		OF 1 SHEETS
799 E. Hill Avenue El Centro, CA 92243 Fax: (760) 353-2686		DRAWN BY: C.D.
		DATE: 01/18/2021
		REVISED: 03/16/2021
		JOB No. 20-142

Noise Impact Assessment

Vega SES 4 Solar Energy Storage Project

County of Imperial, California

Prepared For:

Vega SES 4, LLC
604 Sutter Street
Suite 250
Folsom, California 95630

February 2021



PC ORIGINAL PKG

CONTENTS

1.0 INTRODUCTION 1

 1.1 Project Overview..... 1

 1.2 Project Location..... 1

 1.3 Applicable Land Use Regulations 1

 1.4 Project Site Access..... 2

 1.5 Project Construction 2

2.0 ENVIRONMENTAL NOISE AND GROUNDBORNE VIBRATION ANALYSIS..... 4

 2.1 Fundamentals of Noise and Environmental Sound..... 4

 2.1.1 Addition of Decibels..... 4

 2.1.2 Sound Propagation and Attenuation 6

 2.1.3 Noise Descriptors 7

 2.1.4 Human Response to Noise..... 9

 2.1.5 Effects of Noise on People..... 9

 2.2 Fundamentals of Environmental Groundborne Vibration 10

 2.2.1 Vibration Sources and Characteristics..... 10

3.0 EXISTING ENVIRONMENTAL NOISE SETTING..... 11

 3.1 Noise-Sensitive Land Uses 11

 3.2 Existing Ambient Noise Environment..... 12

4.0 REGULATORY FRAMEWORK..... 12

 4.1 Federal..... 12

 4.1.1 Occupational Safety and Health Act of 1970 12

 4.2 State 13

 4.2.1 State of California General Plan Guidelines 13

 4.2.2 State Office of Planning and Research Noise Element Guidelines 13

 4.3 Local 13

 4.3.1 Imperial County General Plan Noise Element..... 13

5.0 IMPACT ASSESSMENT 17

 5.1 Thresholds of Significance..... 17

 5.2 Methodology 17

 5.3 Impact Analysis 18

 5.3.1 Project Construction Noise..... 18

 5.3.2 Project Operational Noise..... 20

 5.3.3 Project Construction Groundborne Vibration..... 24

 5.3.4 Project Operational Groundborne Vibration..... 25

5.3.5 Excess Airport Noise..... 25
5.3.6 Cumulative Noise 26
6.0 REFERENCES..... 27

LIST OF TABLES

Table 2-1. Common Acoustical Descriptors.....8
Table 2-2. Human Reaction and Damage to Buildings for Continuous or Frequent Intermittent Vibration Levels 11
Table 3-1. Existing (Baseline) Noise Measurements 12
Table 4-1. County of Imperial Property Line Noise Standards..... 19
Table 4-2. County of Imperial Noise Land Use Compatibility Guidelines..... 16
Table 5-1. Construction Average (dBA) Noise/Levels at Nearest Receptor 19
Table 5-2. Modeled Operational Noise Levels at Nearest Sensitive Receptor 22
Table 5-3. Representative Vibration Source Levels for Construction Equipment..... 24
Table 5-4. Construction Vibration Levels at 100 Feet 25

LIST OF FIGURES

Figure 1. Project Location and Vicinity.....3
Figure 2. Common Noise Levels.....5
Figure 3. Project Onsite Source Noise Generation..... 23

ATTACHMENTS

- Attachment A - Baseline (Existing) Noise Measurements – Project Site and Vicinity
- Attachment B - Federal Highway Administration Highway Roadway Construction Noise Outputs – Project Construction Noise
- Attachment C - SoundPLAN Outputs – Onsite Project Noise

LIST OF ACRONYMS AND ABBREVIATIONS

CEQA	California Environmental Quality Act
CNEL	Community Noise Equivalent Level
dB	Decibel
dBA	Decibel is A-weighted
FHWA	Federal Highway Administration

FTA	Federal Transit Administration
L_{eq}	Measure of ambient noise
OPR	Office of Planning and Research
OSHA	Federal Occupational Safety and Health Administration
OSHPD	Office of State Health Planning and Development
PPV	Peak particle velocity
Project	Vega SES 4 Solar Energy Storage Project
A-3-RE	Heavy Agriculture with a Renewable Energy Overlay
RMS	Root mean square
SR	State Route
WEAL	Western Electro-Acoustic Laboratory, Inc.
Aqueduct	All-American Canal

1.0 INTRODUCTION

This report documents the results of a Noise Impact Assessment completed for the Vega SES 4 Solar Energy Storage Project (Project), which includes the construction of a nominal 100-megawatt alternating current (MWAC) solar photovoltaic (PV) energy generation system with an integrated 100 MW battery storage project on approximately 531.53 acres of land in the County of Imperial, California. This report was prepared as a comparison of predicted Project noise levels to noise standards promulgated by the County of Imperial General Plan Noise Element. The purpose of this report is to estimate Project-generated noise and to determine the level of impact the Project would have on the environment.

1.1 Project Overview

The Project proposes to construct a nominal 100 MWAC PV energy generation system, accompanied by a 100 MW battery storage, utilizing either thin film or crystalline solar PV technology modules mounted either on fixed frames or horizontal single-axis tracker (HSAT) systems. The fixed frame PV module arrays would be mounted on racks that would be supported by driven piles. The individual PV systems would be arranged in large arrays by placing them in columns spaced approximately ten feet apart to maximize operational performance and to allow access for panel cleaning and maintenance.

1.2 Project Location

The Project site is an approximately 531.53-acre site located between the California/Mexico border and the All-American Canal (Aqueduct), on the California side in southcentral Imperial County (see Figure 1). The Project site is located approximately 1.92 miles southeast of the Bonds Corner Rd/East Cedar Street/California State Route 98 intersection near the unincorporated community of Bonds Corner. The Project would be located on Imperial County Assessor's Parcel Numbers (APNs) 059-300-015-000 (approximately 301.73 acres), 059-300-017-000 (approximately 148.88 acres) and 059-290-010-000 (approximately 80.92 acres). The irregular shaped site is bound by undeveloped agricultural land to the south, west and east, and the Aqueduct running southwest on the northern border of the proposed Project site. The Project site is currently characterized by flat and undeveloped agricultural land.

1.3 Applicable Land Use Regulations

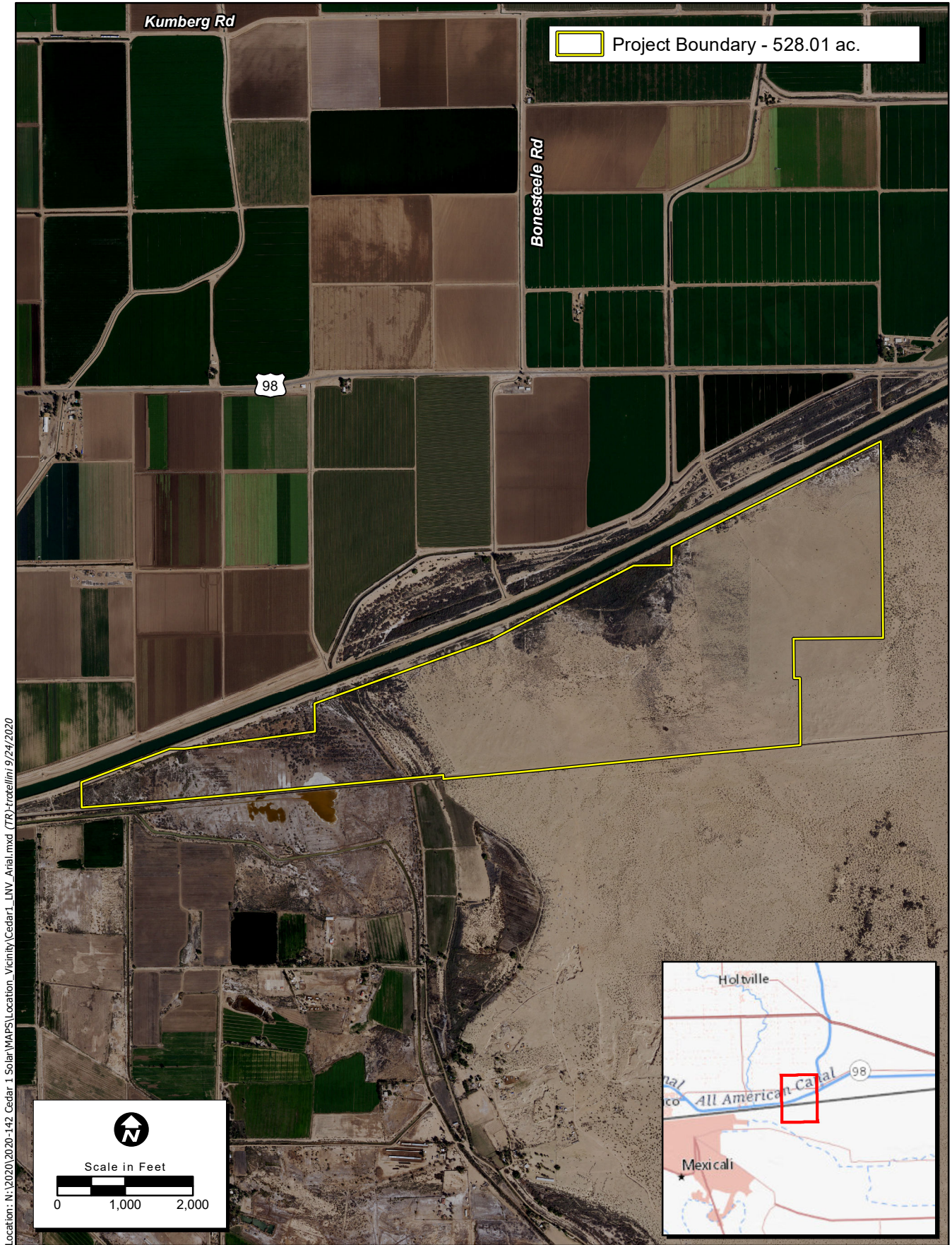
All three of the Project area parcels are designated as "Agriculture" in the Imperial County General Plan and are zoned A-3-RE (Heavy Agriculture with a Renewable Energy Overlay-areas that are suitable for agricultural land uses; to prevent the encroachment of incompatible uses onto and within agricultural lands; and to prohibit the premature conversion of such lands to non-agricultural uses). Pursuant to Section 91703.02 (CONDITIONAL USE PERMITS), Renewable Energy Projects must be located within the Renewable Energy Overlay Zone and may be permitted only through the issuance of a Conditional Use Permit (CUP) as approved by the Approving Authority unless otherwise allowed by applicable law. At present, the Project is located within the Renewable Energy Zone

1.4 Project Site Access

The Project site would include one primary access driveway, currently contemplated across the East Highline Check of the Aqueduct, in the far northeastern corner of the Project area and a secondary access driveway (if required) with a to-be-determined location . This driveway would be provided with a minimum of 30-foot double swing gates with “Knox Box” for keyed entry. Internal to the Project site up to 30-foot wide roads would be provided between the PV arrays, as well as around the perimeter of each Project site inside the perimeter security fence to provide access to all areas of each site for maintenance and emergency vehicles.

1.5 Project Construction

Construction activities would primarily involve demolition and grubbing; grading of the Project area to establish access roads and pads for electrical equipment (inverters and step-up transformers); trenching for underground electrical collection lines; and the installation of solar equipment and security fencing. The construction of the site is estimated to take 12-18 months and would begin in 2022. A temporary, portable construction supply container would be located at the Project site at the beginning of construction and removed at the end of construction. The number of on-site construction workers for the solar project facilities is not expected to exceed 150 workers at any one time. The number of on-site construction workers for the battery storage facility and the substation is not expected to exceed 100 workers at any one time. Onsite parking would be provided for all construction workers.



Location: N:\2020\2020-142_Cedar_1_Solar\WAPS\Location_Vicinity\Cedar1_LINV_Arial.mxd (TR)-truelin\9/24/2020

Map Date: 9/24/2020
 Service Layer Credits:
 Photo Source: NAIP (2018)

Figure 1. Project Location and Vicinity

2020-142 Vega SES 4

2.0 ENVIRONMENTAL NOISE AND GROUNDBORNE VIBRATION ANALYSIS

2.1 Fundamentals of Noise and Environmental Sound

2.1.1 Addition of Decibels

The decibel (dB) scale is logarithmic, not linear, and therefore sound levels cannot be added or subtracted through ordinary arithmetic. Two sound levels 10 dB apart differ in acoustic energy by a factor of 10. When the standard logarithmic decibel is A-weighted (dBA), an increase of 10 dBA is generally perceived as a doubling in loudness. For example, a 70-dBA sound is half as loud as an 80-dBA sound and twice as loud as a 60-dBA sound. When two identical sources are each producing sound of the same loudness, the resulting sound level at a given distance would be three dB higher than one source under the same conditions (Federal Transit Administration [FTA] 2018). For example, a 65-dB source of sound, such as a truck, when joined by another 65 dB source results in a sound amplitude of 68 dB, not 130 dB (i.e., doubling the source strength increases the sound pressure by three dB). Under the decibel scale, three sources of equal loudness together would produce an increase of five dB.

Typical noise levels associated with common noise sources are depicted in Figure 2. *Common Noise Levels*

Common Outdoor Activities	Noise Level (dBA)	Common Indoor Activities
<u>Jet Fly-over at 300m (1000 ft)</u>	110	<u>Rock Band</u>
<u>Gas Lawn Mower at 1 m (3 ft)</u>	100	
<u>Diesel Truck at 15 m (50 ft), at 80 km (50 mph)</u>	90	<u>Food Blender at 1 m (3 ft)</u>
<u>Noisy Urban Area, Daytime</u>	80	<u>Garbage Disposal at 1 m (3 ft)</u>
<u>Gas Lawn Mower, 30 m (100 ft)</u>	70	<u>Vacuum Cleaner at 3 m (10 ft)</u>
<u>Commercial Area</u>		<u>Normal Speech at 1 m (3 ft)</u>
<u>Heavy Traffic at 90 m (300 ft)</u>	60	<u>Large Business Office</u>
<u>Quiet Urban Daytime</u>	50	<u>Dishwasher Next Room</u>
<u>Quiet Urban Nighttime</u>	40	<u>Theater, Large Conference Room (Background)</u>
<u>Quiet Suburban Nighttime</u>		<u>Library</u>
<u>Quiet Rural Nighttime</u>	30	<u>Bedroom at Night,</u>
	20	<u>Concert Hall (Background)</u>
	10	<u>Broadcast/Recording Studio</u>
<u>Lowest Threshold of Human Hearing</u>	0	<u>Lowest Threshold of Human Hearing</u>

Source: California Department of Transportation (Caltrans) 2020a



2.1.2 Sound Propagation and Attenuation

Noise can be generated by a number of sources, including mobile sources such as automobiles, trucks and airplanes, and stationary sources such as construction sites, machinery, and industrial operations. Sound spreads (propagates) uniformly outward in a spherical pattern, and the sound level decreases (attenuates) at a rate of approximately six dB for each doubling of distance from a stationary or point source. Sound from a line source, such as a highway, propagates outward in a cylindrical pattern, often referred to as cylindrical spreading. Sound levels attenuate at a rate of approximately three dB for each doubling of distance from a line source, such as a roadway, depending on ground surface characteristics (Federal Highway Administration [FHWA] 2011). No excess attenuation is assumed for hard surfaces like a parking lot or a body of water. Soft surfaces, such as soft dirt or grass, can absorb sound, so an excess ground-attenuation value of 1.5 dB per doubling of distance is normally assumed. For line sources, an overall attenuation rate of three dB per doubling of distance is assumed (FHWA 2011).

Noise levels may also be reduced by intervening structures; generally, a single row of detached buildings between the receptor and the noise source reduces the noise level by about five dBA (FHWA 2006), while a solid wall or berm generally reduces noise levels by 10 to 20 dBA (FHWA 2011). However, noise barriers or enclosures specifically designed to reduce site-specific construction noise can provide a sound reduction 35 dBA or greater (Western Electro-Acoustic Laboratory, Inc. [WEAL] 2000). To achieve the most potent noise-reducing effect, a noise enclosure/barrier must physically fit in the available space, must completely break the "line of sight" between the noise source and the receptors, must be free of degrading holes or gaps, and must not be flanked by nearby reflective surfaces. Noise barriers must be sizable enough to cover the entire noise source and extend lengthwise and vertically as far as feasibly possible to be most effective. The limiting factor for a noise barrier is not the component of noise transmitted through the material, but rather the amount of noise flanking around and over the barrier. In general, barriers contribute to decreasing noise levels only when the structure breaks the "line of sight" between the source and the receiver.

The manner in which older homes in California were constructed generally provides a reduction of exterior-to-interior noise levels of about 20 to 25 dBA with closed windows (Caltrans 2002). The exterior-to-interior reduction of newer residential units is generally 30 dBA or more (Harris Miller, Miller & Hanson Inc. [HMMH] 2006). Generally, in exterior noise environments ranging from 60 dBA Community Noise Equivalent Level (CNEL) to 65 dBA CNEL, interior noise levels can typically be maintained below 45 dBA, a typically residential interior noise standard, with the incorporation of an adequate forced air mechanical ventilation system in each residential building, and standard thermal-pane residential windows/doors with a minimum rating of Sound Transmission Class (STC) 28. (STC is an integer rating of how well a building partition attenuates airborne sound. In the U.S., it is widely used to rate interior partitions, ceilings, floors, doors, windows, and exterior wall configurations.) In exterior noise environments of 65 dBA CNEL or greater, a combination of forced-air mechanical ventilation and sound-rated construction methods is often required to meet the interior noise level limit. Attaining the necessary noise reduction from exterior to interior spaces is readily achievable in noise environments less than 75 dBA CNEL with proper wall construction techniques following California Building Code methods, the selections of proper windows and doors, and the incorporation of forced-air mechanical ventilation systems.

2.1.3 Noise Descriptors

The decibel scale alone does not adequately characterize how humans perceive noise. The dominant frequencies of a sound have a substantial effect on the human response to that sound. Several rating scales have been developed to analyze the adverse effect of community noise on people. Because environmental noise fluctuates over time, these scales consider that the effect of noise on people is largely dependent on the total acoustical energy content of the noise, as well as the time of day when the noise occurs. The L_{eq} is a measure of ambient noise, while the L_{dn} and CNEL (Community Noise Equivalent Level) are measures of community noise. Each is applicable to this analysis and defined in Table 2-1.

Table 2-1. Common Acoustical Descriptors	
Descriptor	Definition
Decibel, dB	A unit describing the amplitude of sound, equal to 20 times the logarithm to the base 10 of the ratio of the pressure of the sound measured to the reference pressure. The reference pressure for air is 20.
Sound Pressure Level	Sound pressure is the sound force per unit area, usually expressed in micropascals (or 20 micronewtons per square meter), where 1 pascal is the pressure resulting from a force of 1 newton exerted over an area of 1 square meter. The sound pressure level is expressed in decibels as 20 times the logarithm to the base 10 of the ratio between the pressures exerted by the sound to a reference sound pressure (e.g., 20 micropascals). Sound pressure level is the quantity that is directly measured by a sound level meter.
Frequency, Hertz (Hz)	The number of complete pressure fluctuations per second above and below atmospheric pressure. Normal human hearing is between 20 Hz and 20,000 Hz. Infrasonic sound are below 20 Hz and ultrasonic sounds are above 20,000 Hz.
A-Weighted Sound Level, dBA	The sound pressure level in decibels as measured on a sound level meter using the A weighting filter network. The A-weighting filter de-emphasizes the very low and very high frequency components of the sound in a manner similar to the frequency response of the human ear and correlates well with subjective reactions to noise.
Equivalent Noise Level, L_{eq}	The average acoustic energy content of noise for a stated period of time. Thus, the L_{eq} of a time-varying noise and that of a steady noise are the same if they deliver the same acoustic energy to the ear during exposure. For evaluating community impacts, this rating scale does not vary, regardless of whether the noise occurs during the day or the night.
L_{max} , L_{min}	The maximum and minimum A-weighted noise level during the measurement period.
L_{01} , L_{10} , L_{50} , L_{90}	The A-weighted noise levels that are exceeded 1%, 10%, 50%, and 90% of the time during the measurement period.
Day/Night Noise Level, L_{dn} or DNL	A 24-hour average L_{eq} with a 10 dBA “weighting” added to noise during the hours of 10:00 p.m. to 7:00 a.m. to account for noise sensitivity in the nighttime. The logarithmic effect of these additions is that a 60 dBA 24-hour L_{eq} would result in a measurement of 66.4 dBA L_{dn} .
Community Noise Equivalent Level, CNEL	A 24-hour average L_{eq} with a 5 dBA “weighting” during the hours of 7:00 p.m. to 10:00 p.m. and a 10 dBA “weighting” added to noise during the hours of 10:00 p.m. to 7:00 a.m. to account for noise sensitivity in the evening and nighttime, respectively. The logarithmic effect of these additions is that a 60 dBA 24-hour L_{eq} would result in a measurement of 66.7 dBA CNEL.
Ambient Noise Level	The composite of noise from all sources near and far. The normal or existing level of environmental noise at a given location.
Intrusive	That noise which intrudes over and above the existing ambient noise at a given location. The relative intrusiveness of a sound depends on its amplitude, duration, frequency, and time of occurrence and tonal or informational content as well as the prevailing ambient noise level.
Decibel, dB	A unit describing the amplitude of sound, equal to 20 times the logarithm to the base 10 of the ratio of the pressure of the sound measured to the reference pressure. The reference pressure for air is 20.

The A weighted decibel sound level scale gives greater weight to the frequencies of sound to which the human ear is most sensitive. Because sound levels can vary markedly over a short period of time, a method for describing either the average character of the sound or the statistical behavior of the variations must be utilized. Most commonly, environmental sounds are described in terms of an average level that has the same acoustical energy as the summation of all the time-varying events.

The scientific instrument used to measure noise is the sound level meter. Sound level meters can accurately measure environmental noise levels to within about ± 1 dBA. Various computer models are used to predict environmental noise levels from sources, such as roadways and airports. The accuracy of the predicted models depends on the distance between the receptor and the noise source. Close to the noise source, the models are accurate to within about ± 1 to 2 dBA.

2.1.4 Human Response to Noise

The human response to environmental noise is subjective and varies considerably from individual to individual. Noise in the community has often been cited as a health problem, not in terms of actual physiological damage, such as hearing impairment, but in terms of inhibiting general well-being and contributing to undue stress and annoyance. The health effects of noise in the community arise from interference with human activities, including sleep, speech, recreation, and tasks that demand concentration or coordination. Hearing loss can occur at the highest noise intensity levels.

Noise environments and consequences of human activities are usually well represented by median noise levels during the day or night or over a 24-hour period. Environmental noise levels are generally considered low when the CNEL is below 60 dBA, moderate in the 60 to 70 dBA range, and high above 70 dBA. Examples of low daytime levels are isolated, natural settings with noise levels as low as 20 dBA and quiet, suburban, residential streets with noise levels around 40 dBA. Noise levels above 45 dBA at night can disrupt sleep. Examples of moderate-level noise environments are urban residential or semi-commercial areas (typically 55 to 60 dBA) and commercial locations (typically 60 dBA). People may consider louder environments adverse, but most will accept the higher levels associated with noisier urban residential or residential-commercial areas (60 to 75 dBA) or dense urban or industrial areas (65 to 80 dBA). Regarding increases in A-weighted noise levels (dBA), the following relationships should be noted in understanding this analysis:

- Except in carefully controlled laboratory experiments, a change of 1 dBA cannot be perceived by humans.
- Outside of the laboratory, a 3-dBA change is considered a just-perceivable difference.
- A change in level of at least 5 dBA is required before any noticeable change in community response would be expected. An increase of 5 dBA is typically considered substantial.
- A 10-dBA change is subjectively heard as an approximate doubling in loudness and would almost certainly cause an adverse change in community response.

2.1.5 Effects of Noise on People

Hearing Loss

While physical damage to the ear from an intense noise impulse is rare, a degradation of auditory acuity can occur even within a community noise environment. Hearing loss occurs mainly due to chronic exposure to excessive noise but may be due to a single event such as an explosion. Natural hearing loss associated with aging may also be accelerated from chronic exposure to loud noise.

The Occupational Safety and Health Administration (OSHA) has a noise exposure standard that is set at the noise threshold where hearing loss may occur from long-term exposures. The maximum allowable level is 90 dBA averaged over eight hours. If the noise is above 90 dBA, the allowable exposure time is correspondingly shorter.

Annoyance

Attitude surveys are used for measuring the annoyance felt in a community for noises intruding into homes or affecting outdoor activity areas. In these surveys, it was determined that causes for annoyance include interference with speech, radio and television, house vibrations, and interference with sleep and rest. The L_{dn} as a measure of noise has been found to provide a valid correlation of noise level and the percentage of people annoyed. People have been asked to judge the annoyance caused by aircraft noise and ground transportation noise. There continues to be disagreement about the relative annoyance of these different sources. For ground vehicles, a noise level of about 55 dBA L_{dn} is the threshold at which a substantial percentage of people begin to report annoyance.

2.2 Fundamentals of Environmental Groundborne Vibration

2.2.1 Vibration Sources and Characteristics

Sources of earthborne vibrations include natural phenomena (e.g., earthquakes, volcanic eruptions, sea waves, landslides) or manmade causes (explosions, machinery, traffic, trains, construction equipment, etc.). Vibration sources may be continuous (e.g., factory machinery) or transient (e.g., explosions).

Ground vibration consists of rapidly fluctuating motions or waves with an average motion of zero. Several different methods are typically used to quantify vibration amplitude. One is the peak particle velocity (PPV); another is the root mean square (RMS) velocity. The PPV is defined as the maximum instantaneous positive or negative peak of the vibration wave. The RMS velocity is defined as the average of the squared amplitude of the signal. The PPV and RMS vibration velocity amplitudes are used to evaluate human response to vibration.

PPV is generally accepted as the most appropriate descriptor for evaluating the potential for building damage. For human response, however, an average vibration amplitude is more appropriate because it takes time for the human body to respond to the excitation (the human body responds to an average vibration amplitude, not a peak amplitude). Because the average particle velocity over time is zero, the RMS amplitude is typically used to assess human response. The RMS value is the average of the amplitude squared over time, typically a 1- sec. period (FTA 2018).

Table 2-2 displays the reactions of people and the effects on buildings produced by continuous vibration levels. The annoyance levels shown in the table should be interpreted with care since vibration may be found to be annoying at much lower levels than those listed, depending on the level of activity or the sensitivity of the individual. To sensitive individuals, vibrations approaching the threshold of perception can be annoying. Low-level vibrations frequently cause irritating secondary vibration, such as a slight rattling of windows, doors, or stacked dishes. The rattling sound can give rise to exaggerated vibration complaints, even though there is very little risk of actual structural damage. In high-noise environments,

which are more prevalent where groundborne vibration approaches perceptible levels, this rattling phenomenon may also be produced by loud airborne environmental noise causing induced vibration in exterior doors and windows.

Ground vibration can be a concern in instances where buildings shake, and substantial rumblings occur. However, it is unusual for vibration from typical urban sources such as buses and heavy trucks to be perceptible. For instance, heavy-duty trucks generally generate groundborne vibration velocity levels of 0.006 PPV at 50 feet under typical circumstances, which as identified in Table 2-2 is considered very unlikely to cause damage to buildings of any type. Common sources for groundborne vibration are planes, trains, and construction activities such as earth-moving which requires the use of heavy-duty earth moving equipment.

Peak Particle Velocity (inches/second)	Approximate Vibration Velocity Level (VdB)	Human Reaction	Effect on Buildings
0.006–0.019	64–74	Range of threshold of perception	Vibrations unlikely to cause damage of any type
0.08	87	Vibrations readily perceptible	Recommended upper level to which ruins and ancient monuments should be subjected
0.1	92	Level at which continuous vibrations may begin to annoy people, particularly those involved in vibration sensitive activities	Virtually no risk of architectural damage to normal buildings
0.2	94	Vibrations may begin to annoy people in buildings	Threshold at which there is a risk of architectural damage to normal dwellings
0.4–0.6	98–104	Vibrations considered unpleasant by people subjected to continuous vibrations and unacceptable to some people walking on bridges	Architectural damage and possibly minor structural damage

Source: Caltrans 2020b

3.0 EXISTING ENVIRONMENTAL NOISE SETTING

3.1 Noise-Sensitive Land Uses

Noise-sensitive land uses are generally considered to include those uses where noise exposure could result in health-related risks to individuals, as well as places where quiet is an essential element of their intended purpose. Residential dwellings are of primary concern because of the potential for increased and prolonged exposure of individuals to both interior and exterior noise levels. Additional land uses such as hospitals, historic sites, cemeteries, and certain recreation areas are considered sensitive to increases in exterior noise levels. Schools, churches, hotels, libraries, and other places where low interior noise levels are essential are also considered noise-sensitive land uses.

The nearest existing noise-sensitive land use to the Project site is a single-family residence located 1,342 feet from the northeastern corner of Project site.

3.2 Existing Ambient Noise Environment

The Project site consists of flat undeveloped land and is bound by agricultural land to the north with State Route (SR) 98 beyond, agricultural land to the west, vacant undisturbed land to the east, and a mix of vacant undisturbed and agricultural land to the south. In order to quantify existing ambient noise levels in the Project area, ECORP Consulting, Inc. conducted three short-term noise measurements on January 12th, 2021. The noise measurement sites were representative of typical existing noise exposure within and adjacent to the Project site during the daytime (see Attachment A for a visual depiction of the Noise Measurement Locations). The 15-minute measurements were taken between 1:51 p.m. and 2:45 p.m. Short-term (L_{eq}) measurements are considered representative of the noise levels throughout the day. As shown in Table 3-1, the existing noise levels (Baseline) in the Project-vicinity ranges from 65.4 to 68.7 dBA.

Location Number	Location	L_{eq} dBA	L_{min} dBA	L_{max} dBA	Time
1	CA-98 East of Bonds Corner Rd	65.4	36.3	79.8	2:30 p.m.- 2:45 p.m.
2	CA-98 East of Bonesteel Rd	68.7	25.2	86.2	2:10 p.m. – 2:25 p.m.
3	CA-98 Southeastern Extent	66.1	40.8	81.5	1:51 p.m. – 2:06 p.m.

Source: Measurements were taken by ECORP with a Larson Davis LxT SE precision sound level meter, which satisfies the American National Standards Institute for general environmental noise measurement instrumentation. See Attachment A for noise measurement outputs.

The most common noise in the Project vicinity is produced by automotive vehicles (e.g., cars, trucks, buses, motorcycles) traversing SR 98. Traffic moving along streets produces a sound level that remains relatively constant and is part of the minimum ambient noise level in the project vicinity. Vehicular noise varies with the volume, speed and type of traffic. Slower traffic produces less noise than fast-moving traffic. Trucks typically generate more noise than cars. Infrequent or intermittent noise also is associated with vehicles, including sirens, vehicle alarms, slamming of doors, trains, garbage and construction vehicle activity and honking of horns. These noises add to urban noise and are regulated by a variety of agencies.

4.0 REGULATORY FRAMEWORK

4.1 Federal

4.1.1 Occupational Safety and Health Act of 1970

OSHA regulates onsite noise levels and protects workers from occupational noise exposure. To protect hearing, worker noise exposure is limited to 90 decibels with A-weighting (dBA) over an eight-hour work shift (29 Code of Regulations 1910.95). Employers are required to develop a hearing conservation

program when employees are exposed to noise levels exceeding 85 dBA. These programs include provision of hearing protection devices and testing employees for hearing loss on a periodic basis.

4.2 State

4.2.1 State of California General Plan Guidelines

The State of California regulates vehicular and freeway noise affecting classrooms, sets standards for sound transmission and occupational noise control, and identifies noise insulation standards and airport noise/land-use compatibility criteria. The State of California General Plan Guidelines (State of California 2003), published by the Governor's Office of Planning and Research (OPR), also provides guidance for the acceptability of projects within specific CNEL/L_{dn} contours. The guidelines also present adjustment factors that may be used in order to arrive at noise acceptability standards that reflect the noise control goals of the community, the particular community's sensitivity to noise, and the community's assessment of the relative importance of noise pollution.

4.2.2 State Office of Planning and Research Noise Element Guidelines

The State OPR *Noise Element Guidelines* include recommended exterior and interior noise level standards for local jurisdictions to identify and prevent the creation of incompatible land uses due to noise. The Noise Element Guidelines contain a Land Use Compatibility table that describes the compatibility of various land uses with a range of environmental noise levels in terms of the CNEL.

4.3 Local

4.3.1 Imperial County General Plan Noise Element

The County of Imperial General Plan Noise Element establishes maximum allowable average-hourly noise limits for various land use designations (refer to Table 4-1). These noise standards are to be applied at the property line of the noise-generating land use. In instances where the adjoining land use designations differ from that of the noise-generating land use, the more restrictive noise standard shall apply. Where the ambient noise level is equal to or exceeds the property line noise standard, the increase of the existing or proposed noise shall not exceed 3 dBA L_{eq}, which is a just-perceivable increase in noise. L_{eq} is defined as the average acoustic energy content of noise for a stated period of time. Thus, the L_{eq} of a time-varying noise and that of a steady noise are the same if they deliver the same acoustic energy to the ear during exposure.

Land Use Zone	Time Period	Average-Hourly Noise Level (dBA L_{eq})
Residential	7 a.m. - 10 p.m.	50
	10 p.m. - 7 a.m.	45
Multi-residential	7 a.m. - 10 p.m.	55
	10 p.m. - 7 a.m.	50
Commercial	7 a.m. - 10 p.m.	60
	10 p.m. - 7 a.m.	55
Light Industrial/Industrial Park	Any time	70
General Industrial	Any time	75

Source: Imperial County 2015.

Notes: When the noise-generating property and the receiving property have different uses, the more restrictive standard shall apply. When the ambient noise level is equal to or exceeds the Property Line noise standard, the increase of the existing or proposed noise shall not exceed 3 dBA L_{eq}.

Construction Noise Standards

Construction noise, from a single piece of equipment or a combination of equipment, shall not exceed 75 dB L_{eq}, when averaged over an eight (8) hour period, and measured at the nearest sensitive receptor. This standard assumes a construction period, relative to an individual sensitive receptor of days or weeks. In cases of extended length construction times, the standard may be tightened so as not to exceed 75 dB L_{eq} when averaged over a one (1) hour period.

Construction equipment operation are required to be limited to the hours of 7:00 a.m. to 7:00 p.m., Monday through Friday, and 9:00 a.m. to 5:00 p.m. Saturday. No commercial construction operations are permitted on Sunday or holidays. In cases of a person constructing or modifying a residence for himself/herself, and if the work is not being performed as a business, construction equipment operations may be performed on Sundays and holidays between the hours of 9:00 a.m. and 5:00 p.m. Such non-commercial construction activities may be further restricted where disturbing, excessive, or offensive noise causes discomfort or annoyance to reasonable persons of normal sensitivity residing in an area.

Significant Increase of Ambient Noise Levels

The increase of noise levels generally results in an adverse impact to the noise environment. The Noise/Land Use Compatibility Guidelines are not intended to allow the increase of ambient noise levels up to the maximum without consideration of feasible noise reduction measures. The following guidelines are established by the County of Imperial for the evaluation of significant noise impact.

- If the future noise level after a project is completed will be within the "normally acceptable" noise levels shown in the Noise/Land Use Compatibility Guidelines, but will result in an increase of 5 dB CNEL or greater, the project will have a potentially significant noise impact and mitigation measures must be considered.
- If the future noise level after a project is completed will be greater than the "normally acceptable" noise levels shown in the Noise/Land Use Compatibility Guidelines, a noise increase of 3 dB CNEL

or greater shall be considered a potentially significant noise impact and mitigation measures must be considered.

Noise/Land Use Compatibility

The Imperial County General Plan Noise Element Noise/Land Use Compatibility Standards defines the acceptability of a land use in a specified noise environment. Table 4-2 provides the County of Imperial Noise/Land Use Compatibility Guidelines. When an acoustical analysis is performed, conformance of the proposed project with the Noise/Land Use Compatibility Guidelines will be used to evaluate potential noise impact and will provide criteria for environmental impact findings and conditions for project approval.

Land Use Category	Community Noise Exposure L_{dn} or CNEL, dB	Acceptability
Residential	< 60	Normally Acceptable
	60 - 70	Conditionally Acceptable
	70 - 75	Normally Unacceptable
	> 75	Clearly Unacceptable
Transient Lodging-Motels, Hotels	< 60	Normally Acceptable
	60 - 75	Conditionally Acceptable
	75 - 80	Normally Unacceptable
	> 80	Clearly Unacceptable
Schools, Libraries, Churches, Hospitals, Nursing Homes	< 60	Normally Acceptable
	60 - 70	Conditionally Acceptable
	70 - 80	Normally Unacceptable
	> 80	Clearly Unacceptable
Auditoriums, Concert Halls, Amphitheaters	< 70	Conditionally Acceptable
	> 70	Clearly Unacceptable
Sports Arenas, Outdoor Spectator Sports	< 70	Conditionally Acceptable
	70 - 75	Normally Unacceptable
	> 75	Clearly Unacceptable
Playgrounds, Neighborhood Parks	< 70	Normally Acceptable
	70 - 75	Normally Unacceptable
	> 75	Clearly Unacceptable
Golf Courses, Riding Stables, Water Recreation, Cemeteries	< 70	Normally Acceptable
	70 - 80	Normally Unacceptable
	> 80	Clearly Unacceptable
Office Buildings, Business Commercial and Professional	< 65	Normally Acceptable
	65 - 75	Conditionally Acceptable
	75 - 80	Normally Unacceptable
	> 80	Clearly Unacceptable
Industrial, Manufacturing Utilities, Agriculture	< 70	Normally Acceptable
	70 - 75	Conditionally Acceptable
	75 - 80	Normally Unacceptable
	> 80	Clearly Unacceptable

Source: Imperial County 2015.

Notes: Interpretation (For Land Use Planning Purposes):

Normally Acceptable: Specified land use is satisfactory, based upon the assumption that any buildings involved are of normal conventional construction, without any special noise insulation requirements.

Conditionally Acceptable: New construction or development should be undertaken only after a detailed analysis of the noise reduction requirements is made and needed noise insulation features included in the design

Normally Unacceptable: New construction or development should be discouraged. If new construction or development does proceed, a detailed analysis of the noise reduction requirements must be made and needed noise insulation features included in the design.

Clearly Unacceptable: New construction or development clearly should not be undertaken.

5.0 IMPACT ASSESSMENT

5.1 Thresholds of Significance

The impact analysis provided below is based on the following California Environmental Quality Act Guidelines Appendix G thresholds of significance. The project would result in a significant noise-related impact if it would produce:

- 1) Generation of a substantial temporary or permanent increase in ambient noise levels in the vicinity of the project in excess of standards established in the local general plan or noise ordinance, or applicable standards of other agencies.
- 2) Generation of excessive groundborne vibration or groundborne noise levels.
- 3) For a project located within the vicinity of a private airstrip or an airport land use plan or, where such a plan has not been adopted, within two miles of a public airport or public use airport, would the project expose people residing or working in the project area to excessive noise levels.

For purposes of this analysis, Project construction noise is compared to the County's construction noise standard of 75 dBA, when averaged over an eight (8) hour period and measured at the nearest sensitive receptor. Noise generated onsite is compared against the County's property line standards identified in Table 4-1.

5.2 Methodology

This analysis of the existing and future noise environments is based on empirical observations. Predicted construction noise levels were calculated utilizing the FHWA's Roadway Construction Model (2006). Groundborne vibration levels associated with construction-related activities for the Project have been evaluated utilizing typical groundborne vibration levels associated with construction equipment. Potential groundborne vibration impacts related to structural damage and human annoyance were evaluated, taking into account the distance from construction activities to nearby structures and typically applied criteria for structural damage and human annoyance.

In order to estimate the worst-case operational noise levels that may occur at the nearest noise-sensitive receptor, onsite operational noise levels have been calculated with the SoundPLAN 3D noise model (which predicts noise propagation from a noise source based on the location, noise level, and frequency spectra of the noise sources as well as the geometry and reflective properties of the local terrain, buildings, and barriers), coupled with noise measurements that were taken by ECORP Consulting, Inc. (ECORP) at an existing solar energy generation facility. Specifically, ECORP conducted a 30-minute reference noise measurement within the IVC solar generation facility in Imperial County with a Larson Davis SoundExpert LxT precision sound-level meter, which satisfies the American National Standards Institute for general environmental noise measurement instrumentation. This reference measurement identified an ambient noise environment of 47.1 dBA at the existing solar energy generation facility (see Attachment C).

Therefore, a noise level of 47.1 dBA was employed as the reference noise level in the SoundPLAN 3D noise model to determine noise-level propagation associated with Project operations.

5.3 Impact Analysis

5.3.1 Project Construction Noise

Would the Project Result in Short-Term Construction-Generated Noise in Excess of Standards?

Onsite Construction Noise

Construction noise associated with the proposed Project would be temporary and would vary depending on the nature of the activities being performed. Noise generated would primarily be associated with the operation of off-road equipment for onsite construction activities as well as construction vehicle traffic on area roadways. Construction noise typically occurs intermittently and varies depending on the nature or phase of construction (e.g., land clearing, grading, excavation, paving). Noise generated by construction equipment, including earth movers, material handlers, and portable generators, can reach high levels. Typical operating cycles for these types of construction equipment may involve one or two minutes of full power operation followed by three to four minutes at lower power settings. Other primary sources of acoustical disturbance would be random incidents, which would last less than one minute (such as dropping large pieces of equipment or the hydraulic movement of machinery lifts). During construction, exterior noise levels could negatively affect sensitive land uses in the vicinity of the construction site.

Nearby noise-sensitive land uses consist of a scattering of single-family residential units located within 1 mile of the proposed Project site boundary to the north across the Aqueduct. The closest sensitive receptor is located 1,342 feet from the northeastern corner of the Project site. As previously described, the County's General Plan Noise Element states construction equipment operation shall be limited to the hours of 7:00 a.m. to 7:00 p.m., Monday through Friday, and 9:00 a.m. to 5:00 p.m. on Saturdays. No commercial construction operations are permitted on Sundays or holidays. Construction noise, from a single piece of equipment or a combination of equipment, shall not exceed 75 dB L_{eq} , when averaged over an eight (8) hour period, and measured at the nearest sensitive receptor. This standard assumes a construction period, relative to an individual sensitive receptor of days or weeks. In cases of extended length construction times, the standard may be tightened so as not to exceed 75 dB L_{eq} when averaged over a one (1) hour period.

The anticipated short-term construction noise levels generated for the necessary construction equipment are presented in Table 5-1.

Table 5-1. Construction Average (dBA) Noise Levels at Nearest Receptor			
Equipment	Estimated Exterior Construction Noise Level at Existing Residences	Construction Noise Standards (dBA L_{eq})	Exceeds Standards?
Site Preparation			
Rubber Tired Dozers (2)	46.6 (each)	75	No
Tractors/Loaders/Backhoes (2)	51.4 (each)	75	No
Combined Site Preparation Equipment	55.7	75	No
Grading			
Excavators (4)	48.2 (each)	75	No
Graders (3)	52.4 (each)	75	No
Rubber Tired Dozers (2)	49.1 (each)	75	No
Scrapers (2)	51 (each)	75	No
Tractors/Loaders/Backhoes (4)	51.4 (each)	75	No
Combined Grading Equipment	62.5	75	No
Facility Construction			
Crane	44	75	No
Paver	45.6	75	No
Paving Equipment (2)	53.9 (each)	75	No
Pile Drivers (4)	65.7 (each)	75	No
Rollers (2)	44.4 (each)	75	No
Rough Terrain Forklifts (4)	50.8 (each)	75	No
Tractors/Loaders/Backhoes (4)	51.4 (each)	75	No
Trenchers (2)	48.8 (each)	75	No
Combined Construction, Trenching, & Paving	72.2	75	No

Source: Construction noise levels were calculated by ECRP Consulting using the FHWA Roadway Noise Construction Model (FHWA 2006). Refer to Attachment B for Model Data Outputs.

Notes: The nearest residence is located approximately 1,342 feet from the Project boundary.

L_{eq} = The equivalent energy noise level, is the average acoustic energy content of noise for a stated period of time. Thus, the L_{eq} of a time-varying noise and that of a steady noise are the same if they deliver the same acoustic energy to the ear during exposure. For evaluating community impacts, this rating scale does not vary, regardless of whether the noise occurs during the day or the night.

As shown in Table 5-1, no individual or cumulative pieces of construction equipment would exceed the 75 dBA County construction noise standard during any phase of construction at the nearby noise-sensitive receptors.

Offsite Construction Worker Traffic Noise

Project construction would result in additional traffic on adjacent roadways over the time period that construction occurs. As previously stated, the number of on-site construction workers for the solar project facilities is not expected to exceed 150 workers at any one time. The number of on-site construction workers for the battery storage facility and the substation is not expected to exceed 100 workers at any one time. Onsite parking would be provided for all construction workers. According to KOA Corporation (2020), a maximum of 510 daily automobile trips would be generated during Project construction, accounting for construction worker commutes and equipment deliveries. The majority of these trips are expected to be accommodated on SR 98, SR 7, and Interstate 8. According to the California Department of Transportation (Caltrans) *Technical Noise Supplement to the Traffic Noise Analysis Protocol* (2013), doubling of traffic on a roadway is required to result in an increase of 3 dB (outside of the laboratory, a 3-dBA change is considered a just-perceivable difference). According to the Caltrans Traffic Census Program (2018), SR 98 currently accommodates 2,400 average daily traffic trips, while SR 7 and Interstate 8 accommodate 6,700 average daily trips and 14,000 average daily trips, respectively. Thus, the estimated 510 daily trips during Project construction would not result in a doubling of traffic on these facilities, and its contribution to existing traffic noise would not be perceptible. Bonds Corner Road and W. Heber Road are also projected to accommodate construction-related traffic with an estimated 69 daily trips on Bonds Corner Road and 5 daily trips on W. Heber Road over the course of construction. These two facilities are classified as "minor arterial" roads by the County General Plan Circulation and Scenic Highways Element (2008) which are expected to accommodate approximately 14,800 daily trips. While the Circulation and Scenic Highways Element does not identify specific traffic counts for Bonds Corner Road, it estimates between 2,020 and 16,700 average daily trips on W. Heber Road.

The Project construction would not result in a doubling of traffic, and therefore its contribution to existing traffic noise would not be perceptible.

5.3.2 Project Operational Noise**Would the Project Result in a Substantial Permanent Increase in Ambient Noise Levels in Excess of County or City Standards During Operations?**

As previously described, noise-sensitive land uses are locations where people reside or where the presence of unwanted sound could adversely affect the use of the land. Residences, schools, hospitals, guest lodging, libraries, and some passive recreation areas would each be considered noise-sensitive and may warrant unique measures for protection from intruding noise. The nearest existing noise-sensitive land use to the Project site is a single-family residential unit located approximately 1,342 feet north of the proposed Project site boundary, across the Aqueduct.

Operational Offsite Traffic Noise

Project operations would result in minimal additional traffic on adjacent roadways. The only visitors to the site would be that of repair or maintenance workers, whose presence at the site would be necessary infrequently and inconsistently. According to the California Department of Transportation (Caltrans) *Technical Noise Supplement to the Traffic Noise Analysis Protocol* (2013), doubling of traffic on a roadway

is required to result in an increase of 3 dB (outside of the laboratory, a 3-dBA change is considered a just-perceivable difference). The proposed Project would not result in a doubling of traffic, and therefore its contribution to existing traffic noise would not be perceptible.

Project Land Use Compatibility

The County uses the land use compatibility standards presented in the General Plan Noise Element that provides the County with a tool to gauge the compatibility of new land uses relative to existing noise levels. This table, presented as Table 4-2, identifies acceptable noise levels for various land uses. In the case that the noise levels identified at the proposed Project site fall within the “acceptable” levels presented in the General Plan, the Project is considered compatible with the existing noise environment.

As previously stated, the Project site is proposing to develop a 100 MWAC PV solar energy generation and storage facility. The proposed Project site is zoned A-3-RE (Heavy Agriculture with a Renewable Energy Overlay). As shown in Table 4-2, a normally acceptable noise standard for agricultural land uses is 69 dBA CNEL or under. In order to quantify existing ambient noise levels in the Project area, ECORP conducted three short-term noise measurements on January 12th, 2021. The noise measurement sites were representative of typical existing noise exposure in the Project vicinity and are considered representative of the noise levels throughout the day. As shown in Table 3-1, the ambient noise level recorded in the vicinity of the Project site ranges from 65.4 dBA to 68.7 dBA. However, it is noted that these short-term measurements were each conducted over 1,000 feet from the Project site and adjacent to SR 98, a substantial noise source. Thus, the ambient noise levels experienced on the actual Project site would most likely be less.

Additionally, according to Table 4 of the County General Plan Noise Element (2015), the segment of SR 98 traversing the Project site currently experiences noise levels of 60 dBA CNEL at 33 feet. Since the site is over 1,000 feet south of SR 98 and there are no consistent sources of noise in between the Project site and SR 98, it can be assumed that noise levels on the Project site are less than 60 dBA CNEL. SR 98 is the dominate source of noise in the Project vicinity. This General Plan Noise Element data is reported in the noise metric, CNEL, which is the same noise metric promulgated by County noise compatibility guidelines contained in Table 4-2. As these noise levels fall below the noise standard, the Project site is considered an appropriate noise environment to locate the proposed land use.

Project Operations-Onsite Noise Sources

As previously stated, noise sensitive land uses are locations where people reside or where the presence of unwanted sound could adversely affect the use of the land. Residences, schools, hospitals, guest lodging, libraries, and some passive recreation areas would each be considered noise-sensitive and may warrant unique measures for protection from intruding noise. The nearest existing noise-sensitive land use to the Project site consists of a single-family residence located 1,342 feet from the proposed Project site boundary, to the north and across the Aqueduct.

The main stationary operational noise associated with the Project would be from the proposed transformers, inverters, substation, and transmission lines. Onsite Project operations have been calculated using the SoundPLAN 3D noise model. As previously stated, a noise level of 47.1 dBA was employed as

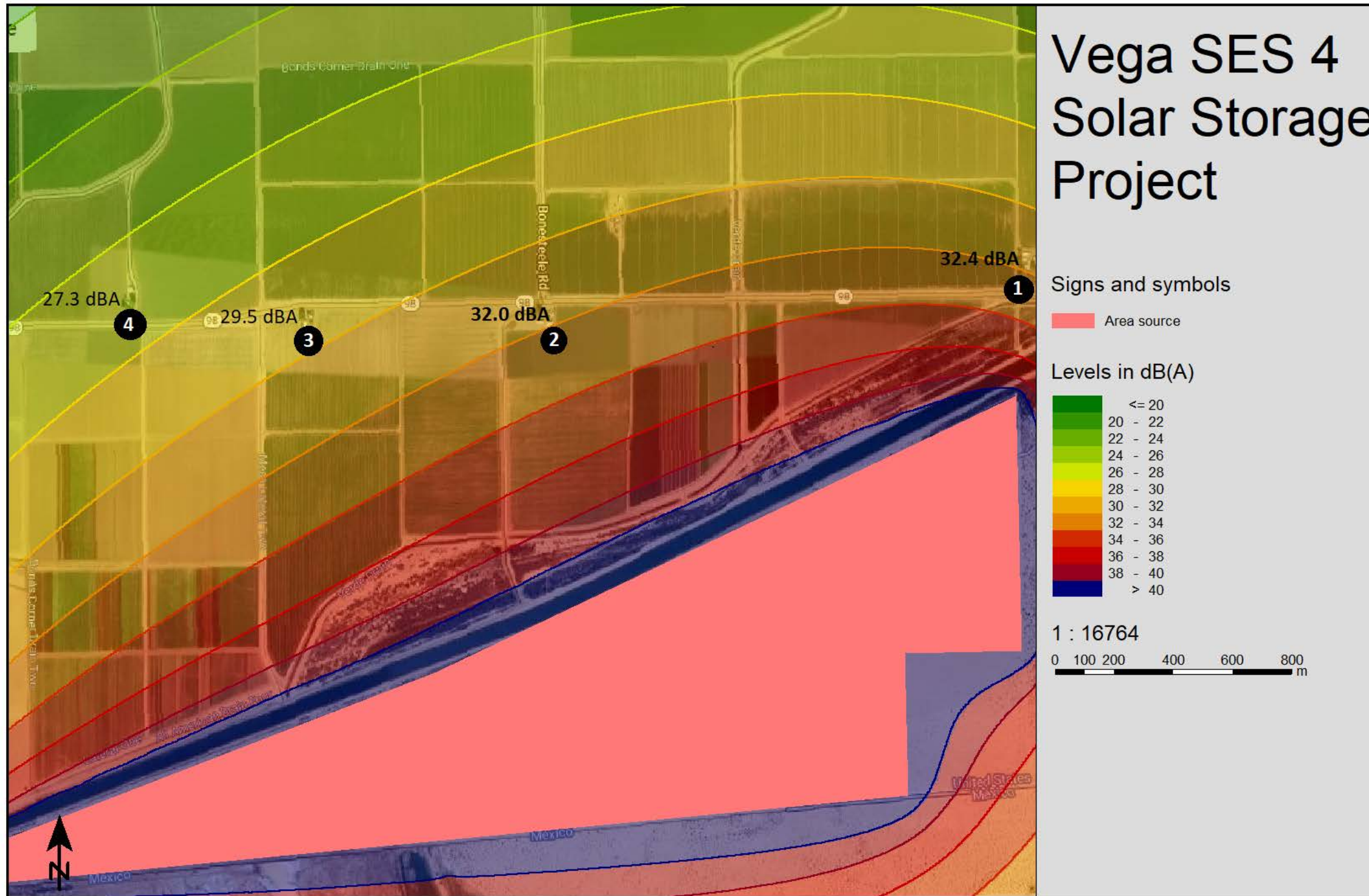
the reference noise level in the SoundPLAN 3D noise model to determine noise-level propagation associated with the Project operations. The results of this model can be found in Appendix C. Table 5-2 shows the predicted Project noise levels at the nearest noise-sensitive land use in the Project vicinity, as predicted by SoundPLAN. Also see Figure 3.

Location	Modeled Operational Noise Attributed to Project (L_{eq} dBA)	County Daytime Standard (L_{eq} dB)	County Nighttime Standard (L_{eq} dB)	Exceed Standard?
Property line of the nearest residence	32.4	50.0	45.0	No

Source: Stationary source noise levels were modeled by ECORP using SoundPLAN 3D noise model. Refer to Appendix C for noise modeling assumptions and results.

Note: Reference noise measurement used to calculate Project onsite noise propagation identified at 47.1 dBA, per 30-minute measurements taken at a VEGA SES 4 solar generation facility in Imperial County.

As shown in Table 5-2, Project operational noise would not exceed County daytime or nighttime standards.



Map Date: 1/27/2021
 Photo (or Base) Source: SoundPLAN 3D Noise Model, v. 5.1



Figure 3. Project Onsite Source Noise Generation

2020-142 Vega 4

5.3.3 Project Construction Groundborne Vibration

Would the Project Expose Structures to Substantial Groundborne Vibration During Construction?

Excessive groundborne vibration impacts result from continuously occurring vibration levels. Increases in groundborne vibration levels attributable to the Project would be primarily associated with short-term construction-related activities. Construction on the Project site would have the potential to result in varying degrees of temporary groundborne vibration, depending on the specific construction equipment used and the operations involved. Ground vibration generated by construction equipment spreads through the ground and diminishes in magnitude with increases in distance.

Construction-related ground vibration is normally associated with impact equipment such as pile drivers, jackhammers, and the operation of some heavy-duty construction equipment, such as dozers and trucks. It is noted that pile drivers would not be necessary during Project construction. Vibration decreases rapidly with distance and it is acknowledged that construction activities would occur throughout the Project site and would not be concentrated at the point closest to sensitive receptors. Groundborne vibration levels associated with typical construction equipment at 25 feet distant are summarized in Table 5-3.

Table 5-3. Representative Vibration Source Levels for Construction Equipment	
Equipment Type	Peak Particle Velocity at 25 Feet (inches per second)
Large Bulldozer	0.089
Caisson Drilling	0.089
Loaded Trucks	0.076
Hoe Ram	0.089
Jackhammer	0.035
Small Bulldozer/Tractor	0.003
Vibratory Roller	0.210

Source: FTA 2018; Caltrans 2020b

The County of Imperial does not regulate vibrations associated with construction. However, a discussion of construction vibration is included for full disclosure purposes. For comparison purposes, the Caltrans (2020b) recommended standard of 0.2 inch per second PPV with respect to the prevention of structural damage for older residential buildings is used as a threshold. This is also the level at which vibrations may begin to annoy people in buildings. Consistent with FTA recommendations for calculating construction vibration, construction vibration was measured from the center of the Project site (FTA 2018). The nearest structure of concern to the construction site, with regard to groundborne vibrations, is the Aqueduct located 100 feet from the proposed Project site boundary.

Based on the representative vibration levels presented for various construction equipment types in Table 5-3 and the construction vibration assessment methodology published by the FTA (2018), it is possible to estimate the potential project construction vibration levels. The FTA provides the following equation:

$$[PPV_{equip} = PPV_{ref} \times (25/D)^{1.5}]$$

Table 5-4 presents the expected Project related vibration levels at a distance of 100 feet.

Table 5-4. Construction Vibration Levels at 100 Feet							
Receiver PPV Levels (in/sec) ¹					Peak Vibration	Threshold	Exceed Threshold
Large Bulldozer, Caisson Drilling, & Hoe Ram	Loaded Trucks	Jackhammer	Small Bulldozer	Vibratory Roller			
0.011	0.009	0.004	0.000	0.026	0.026	0.2	No

Notes: ¹Based on the Vibration Source Levels of Construction Equipment included on Table 5-5 (FTA 2018). Distance to the nearest structure of concern is approximately 100 feet measured from project site boundary.

As shown in Table 5-4, vibration as a result of construction activities would not exceed 0.2 PPV at the nearest structure. Thus, project construction would not exceed the recommended threshold.

5.3.4 Project Operational Groundborne Vibration

Would the Project Expose Structures to Substantial Groundborne Vibration During Operations?

Project operations would not include the use of any large-scale stationary equipment that would result in excessive vibration levels. Therefore, the project would not result groundborne vibration impacts during operations.

5.3.5 Excess Airport Noise

Would the Project Expose People Residing or Working in the Project area to Excessive Airport Noise?

The Project site is located approximately 12 miles east from the Calexico International Airport in Unincorporated lands of Imperial County and 8.69 miles from Calexico city limits. The Imperial County Airport Land Use Commission has established a set of land use compatibility criteria for lands surrounding the airports in Imperial County in the Imperial County Airport Land Use Compatibility Plan (1996). As identified in Figure 3-B of the Imperial County Airport Land Use Compatibility Maps, the proposed Project site lays outside of the noise contours of the Calexico International Airport. Thus, the Project would not expose residents to excessive airport noise.

5.3.6 Cumulative Noise

Would the Project Contribute to Cumulatively Considerable Noise During Construction?

Construction activities associated with the proposed Project and other construction projects in the area may overlap, resulting in construction noise in the area. However, construction noise impacts primarily affect the areas adjacent to the construction site. Construction noise for the proposed Project was determined to be less than significant following compliance with County noise standards. Cumulative development in the vicinity of the Project site could result in elevated construction noise levels at sensitive receptors in the Project area. However, each project would be required to comply with the applicable noise limitations on construction. Therefore, the Project would not contribute to cumulative impacts during construction.

Would the Project Contribute to Cumulatively Considerable Noise from Offsite Traffic?

As described previously, Project operations would result in extremely minimal additional traffic on adjacent roadways. The only visitors to the site would be that of repair or maintenance work that would be done very infrequently. Thus, any cumulative noise impacts from project-related traffic would be minimal. Therefore, the Project's contribution to cumulative noise impacts from traffic would be less than significant.

Would the Project Contribute to Cumulatively Considerable Noise from Stationary Sources?

Cumulative noise impacts would primarily be associated with the transformers, inverters, substation, and transmission lines from the solar facility. Long-term noise sources associated with development at the Project, combined with other cumulative projects, could cause local noise-level increases. Noise levels associated with the proposed Project and related cumulative projects together could result in higher noise levels than considered separately. However, noise increase as a result of the Project would not be perceivable and would not exceed County standards.

6.0 REFERENCES

- Caltrans. 2020a. IS/EA Annotated Outline. <http://www.dot.ca.gov/ser/vol1/sec4/ch31ea/chap31ea.htm>.
- _____. 2020b. Transportation and Construction Vibration Guidance Manual.
- _____. 2018. Traffic Census Program: 2017 Traffic Volumes. <https://dot.ca.gov/programs/traffic-operations/census>
- _____. 2013. Technical Noise Supplement to the Traffic Noise Analysis Protocol.
- FHWA. 2011. Effective Noise Control During Nighttime Construction. Available online at: http://ops.fhwa.dot.gov/wz/workshops/accessible/schexnayder_paper.htm.
- _____. 2006. Roadway Construction Noise Model.
- FTA. 2018. Transit Noise and Vibration Impact Assessment.
- HMMH. 2006. Transit Noise and Vibration Impact Assessment, Final Report.
- Imperial, County of. 2015. General Plan Noise Element.
- _____. 2008. General Plan Circulation and Scenic Highways Element.
- _____. 1996. Imperial County Airport Land Use Compatibility Plan.
- KOA Corporation. 2020. Scoping Memorandum for the Traffic Impact Study.
- OPR. 2003. State of California General Plan Guidelines.
- WEAL. 2000. Sound Transmission Sound Test Laboratory Report No. TL 96-186.

LIST OF ATTACHMENTS

Attachment A - Baseline (Existing) Noise Measurements – Project Site and Vicinity

Attachment B - Federal Highway Administration Highway Roadway Construction Noise Outputs
– Project Construction Noise

Attachment C - SoundPLAN 3-D Noise Model Outputs – Project Onsite Noise

Baseline (Existing) Noise Measurements – Project Site and Vicinity



Map Date: 12/14/2020
 Photo (or Base) Source: Google Earth Pro

Site Number: V4-1			
Recorded By: Jessie Beckman			
Job Number: 2020 - 142			
Date: 1/12/21			
Time: 14:30 – 14:45			
Location: CA-98, East of Bonds Corner Rd			
Source of Peak Noise: Vehicular traffic on CA-98			
Noise Data			
Leq (dB)	Lmin (dB)	Lmax (dB)	Peak (dB)
65.4	36.3	79.8	104.3

Equipment						
Category	Type	Vendor	Model	Serial No.	Cert. Date	Note
Sound	Sound Level Meter	Larson Davis	LxT SE	0005120	9/14/2020	
	Microphone	Larson Davis	377B02	174464	9/14/2020	
	Preamp	Larson Davis	PRMLxT1L	042852	9/14/2020	
	Calibrator	Larson Davis	CAL200	14105	9/10/2020	
Weather Data						
Est.	Duration: 15 minutes			Sky: 50%cc		
	Note: Cal Offset = 0.26			Sensor Height (ft): 3.5		
	Wind Ave Speed (mph)		Temperature (degrees Fahrenheit)		Barometer Pressure (hPa)	
	0-2		70		30.25Hg	

Photo of Measurement Location



PC ORIGINAL PKG

Measurement Report

Report Summary

Meter's File Name	LxT_Data.356	Computer's File Name	SLM_0005120_LxT_Data_356.00.ldbin
Meter	LxT SE		
Firmware	2.404		
User	Lindsay Liegler	Location	
Description			
Note			
Start Time	2021-01-12 13:51:20	Duration	0:15:00.0
End Time	2021-01-12 14:06:20	Run Time	0:15:00.0
		Pause Time	0:00:00.0

Results

Overall Metrics

LA _{eq}	65.4 dB		
LAE	95.0 dB	SEA	--- dB
EA	349.6 μPa²h		
LZ _{peak}	104.3 dB	2021-01-12 13:55:26	
LAS _{max}	79.8 dB	2021-01-12 13:55:26	
LAS _{min}	36.3 dB	2021-01-12 13:58:17	
LA _{eq}	65.4 dB		
LC _{eq}	72.8 dB	LC _{eq} - LA _{eq}	7.4 dB
LAI _{eq}	68.4 dB	LAI _{eq} - LA _{eq}	3.0 dB

Exceedances

	Count	Duration
LAS > 85.0 dB	0	0:00:00.0
LAS > 115.0 dB	0	0:00:00.0
LZ _{peak} > 135.0 dB	0	0:00:00.0
LZ _{peak} > 137.0 dB	0	0:00:00.0
LZ _{peak} > 140.0 dB	0	0:00:00.0

Community Noise

LDN	LDay	LNight	
65.4 dB	65.4 dB	0.0 dB	
LDEN	LDay	LEve	LNight
65.4 dB	65.4 dB	--- dB	--- dB

Any Data

	A		C		Z	
	Level	Time Stamp	Level	Time Stamp	Level	Time Stamp
L _{eq}	65.4 dB		72.8 dB		--- dB	
LS _(max)	79.8 dB	2021-01-12 13:55:26	--- dB		--- dB	
LS _(min)	36.3 dB	2021-01-12 13:58:17	--- dB		--- dB	
L _{Peak(max)}	--- dB		--- dB		104.3 dB	2021-01-12 13:55:26

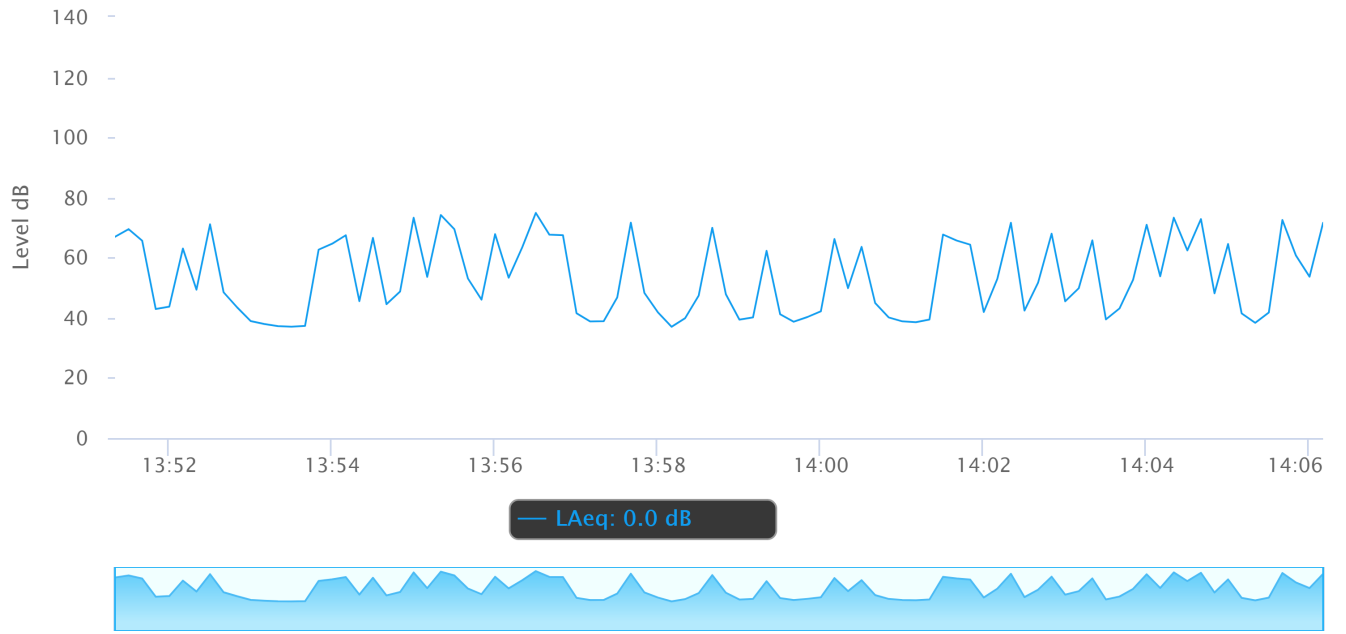
Overloads

Count	Duration	OBA Count	OBA Duration
0	0:00:00.0	20	0:01:04.10

Statistics

LAS 5.0	73.3 dB
LAS 10.0	70.1 dB
LAS 33.3	55.2 dB
LAS 50.0	48.2 dB
LAS 66.6	43.3 dB
LAS 90.0	38.6 dB

Time History



Site Number: V4-2			
Recorded By: Jessie Beckman			
Job Number: 2020 - 142			
Date: 1/12/21			
Time: 14:10 – 14:25			
Location: CA-98, East of Bonesteel Rd			
Source of Peak Noise: Vehicular traffic on CA-98			
Noise Data			
Leq (dB)	Lmin (dB)	Lmax (dB)	Peak (dB)
68.7	25.2	86.2	106.8

Equipment						
Category	Type	Vendor	Model	Serial No.	Cert. Date	Note
Sound	Sound Level Meter	Larson Davis	LxT SE	0005120	9/14/2020	
	Microphone	Larson Davis	377B02	174464	9/14/2020	
	Preamp	Larson Davis	PRMLxT1L	042852	9/14/2020	
	Calibrator	Larson Davis	CAL200	14105	9/10/2020	
Weather Data						
Est.	Duration: 15 minutes			Sky: 50%cc		
	Note: Cal Offset = 0.26			Sensor Height (ft): 3.5		
	Wind Ave Speed (mph)		Temperature (degrees Fahrenheit)		Barometer Pressure (hPa)	
	0-2		70		30.25Hg	

Photo of Measurement Location



Measurement Report

Report Summary

Meter's File Name	LxT_Data.357	Computer's File Name	SLM_0005120_LxT_Data_357.00.ldbin
Meter	LxT SE		
Firmware	2.404		
User	Lindsay Liegler	Location	
Description			
Note			
Start Time	2021-01-12 14:10:16	Duration	0:15:00.0
End Time	2021-01-12 14:25:16	Run Time	0:15:00.0
		Pause Time	0:00:00.0

Results

Overall Metrics

LA _{eq}	68.7 dB		
LAE	98.2 dB	SEA	--- dB
EA	742.4 μPa²h		
LZ _{peak}	106.8 dB	2021-01-12 14:23:46	
LAS _{max}	86.2 dB	2021-01-12 14:23:46	
LAS _{min}	25.2 dB	2021-01-12 14:21:16	
LA _{eq}	68.7 dB		
LC _{eq}	75.5 dB	LC _{eq} - LA _{eq}	6.8 dB
LAI _{eq}	72.4 dB	LAI _{eq} - LA _{eq}	3.7 dB

Exceedances

	Count	Duration
LAS > 85.0 dB	1	0:00:01.5
LAS > 115.0 dB	0	0:00:00.0
LZ _{peak} > 135.0 dB	0	0:00:00.0
LZ _{peak} > 137.0 dB	0	0:00:00.0
LZ _{peak} > 140.0 dB	0	0:00:00.0

Community Noise

LDN	LDay	LNight	
68.7 dB	68.7 dB	0.0 dB	
LDEN	LDay	LEve	LNight
68.7 dB	68.7 dB	--- dB	--- dB

Any Data

	A		C		Z	
	Level	Time Stamp	Level	Time Stamp	Level	Time Stamp
L _{eq}	68.7 dB		75.5 dB		--- dB	
LS _(max)	86.2 dB	2021-01-12 14:23:46	--- dB		--- dB	
LS _(min)	25.2 dB	2021-01-12 14:21:16	--- dB		--- dB	
L _{Peak(max)}	--- dB		--- dB		106.8 dB	2021-01-12 14:23:46

Overloads

Count	Duration	OBA Count	OBA Duration
0	0:00:00.0	32	0:01:38.2

Statistics

LAS 5.0	76.8 dB
LAS 10.0	72.9 dB
LAS 33.3	53.2 dB
LAS 50.0	46.9 dB
LAS 66.6	42.5 dB
LAS 90.0	35.9 dB

Site Number: V4 - 3			
Recorded By: Jessie Beckman			
Job Number: 2020 - 142			
Date: 1/12/2021			
Time: 13:51 – 14:06			
Location: CA-98, Southeastern Extent			
Source of Peak Noise: Vehicular Traffic on CA-98			
Noise Data			
Leq (dB)	Lmin (dB)	Lmax (dB)	Peak (dB)
66.1	40.8	81.5	103.8

Equipment						
Category	Type	Vendor	Model	Serial No.	Cert. Date	Note
Sound	Sound Level Meter	Larson Davis	LxT SE	0005120	9/14/2020	
	Microphone	Larson Davis	377B02	174464	9/14/2020	
	Preamp	Larson Davis	PRMLxT1L	042852	9/14/2020	
	Calibrator	Larson Davis	CAL200	14105	9/10/2020	
Weather Data						
Est.	Duration: 15 minutes			Sky: 40% cc		
	Note: dBA Offset = 0.01 Cal Offset = 0.26			Sensor Height (ft): 3.5		
	Wind Ave Speed (mph)		Temperature (degrees Fahrenheit)		Barometer Pressure (hPa)	
	0-2		70		30.25 Hg	

Photo of Measurement Location



Measurement Report

Report Summary

Meter's File Name	LxT_Data.358	Computer's File Name	SLM_0005120_LxT_Data_358.00.ldbin
Meter	LxT SE		
Firmware	2.404		
User	Lindsay Liegler	Location	
Description			
Note			
Start Time	2021-01-12 14:29:25	Duration	0:15:00.0
End Time	2021-01-12 14:44:25	Run Time	0:15:00.0
		Pause Time	0:00:00.0

Results

Overall Metrics

LA _{eq}	66.1 dB		
LAE	95.7 dB	SEA	--- dB
EA	411.7 µPa²h		
LZ _{peak}	103.8 dB	2021-01-12 14:31:03	
LAS _{max}	81.5 dB	2021-01-12 14:29:25	
LAS _{min}	40.8 dB	2021-01-12 14:43:50	
LA _{eq}	66.1 dB		
LC _{eq}	73.5 dB	LC _{eq} - LA _{eq}	7.4 dB
LAI _{eq}	69.5 dB	LAI _{eq} - LA _{eq}	3.3 dB

Exceedances

	Count	Duration
LAS > 85.0 dB	0	0:00:00.0
LAS > 115.0 dB	0	0:00:00.0
LZ _{peak} > 135.0 dB	0	0:00:00.0
LZ _{peak} > 137.0 dB	0	0:00:00.0
LZ _{peak} > 140.0 dB	0	0:00:00.0

Community Noise

LDN	LDay	LNight	
66.1 dB	66.1 dB	0.0 dB	
LDEN	LDay	LEve	LNight
66.1 dB	66.1 dB	--- dB	--- dB

Any Data

	A		C		Z	
	Level	Time Stamp	Level	Time Stamp	Level	Time Stamp
L _{eq}	66.1 dB		73.5 dB		--- dB	
LS _(max)	81.5 dB	2021-01-12 14:29:25	--- dB		--- dB	
LS _(min)	40.8 dB	2021-01-12 14:43:50	--- dB		--- dB	
L _{Peak(max)}	--- dB		--- dB		103.8 dB	2021-01-12 14:31:03

Overloads

Count	Duration	OBA Count	OBA Duration
0	0:00:00.0	23	0:01:11.1

Statistics

LAS 5.0	74.0 dB
LAS 10.0	70.9 dB
LAS 33.3	56.4 dB
LAS 50.0	50.4 dB
LAS 66.6	46.6 dB
LAS 90.0	42.5 dB

Federal Highway Administration Highway Roadway Construction Noise Outputs – Project
Construction Noise

Roadway Construction Noise Model (RCNM),Version 1.1

Report date: 1/25/2021
 Case Description: Site Prep

Description Affected Land Use
 Site Prep Residential

Description	Impact Device	Usage(%)	Equipment		Receptor Distance (feet)
			Spec Lmax (dBA)	Actual Lmax (dBA)	
Rubber Tired Loader	No	40		79.1	1342
Rubber Tired Loader	No	40		79.1	1342
Tractor	No	40	84		1342
Tractor	No	40	84		1342

Calculated (dBA)

Equipment	*Lmax	Leq
Rubber Tired Loader	50.5	46.6
Rubber Tired Loader	50.5	46.6
Tractor	55.4	51.4
Tractor	55.4	51.4
Total	55.4	55.7

*Calculated Lmax is the Loudest value.

Roadway Construction Noise Model (RCNM),Version 1.1

Report date: 1/25/2021
 Case Description: Grading

Description Affected Land Use
 Grading Residential

Description	Impact Device	Usage(%)	Equipment		Receptor Distance (feet)
			Spec Lmax (dBA)	Actual Lmax (dBA)	
Excavator	No	40		80.7	1342
Excavator	No	40		80.7	1342
Excavator	No	40		80.7	1342
Excavator	No	40		80.7	1342
Grader	No	40	85		1342
Grader	No	40	85		1342
Grader	No	40	85		1342
Rubber Tired Dozer	No	40		81.7	1342
Rubber Tired Dozer	No	40		81.7	1342
Scraper	No	40		83.6	1342
Scraper	No	40		83.6	1342
Tractor/Loader/Backhoe	No	40	84		1342
Tractor/Loader/Backhoe	No	40	84		1342
Tractor/Loader/Backhoe	No	40	84		1342
Tractor/Loader/Backhoe	No	40	84		1342

Calculated (dBA)

Equipment	*Lmax	Leq
Excavator	52.1	48.2
Excavator	52.1	48.2
Excavator	52.1	48.2
Excavator	52.1	48.2
Grader	56.4	52.4
Grader	56.4	52.4
Grader	56.4	52.4
Rubber Tired Dozer	53.1	49.1
Rubber Tired Dozer	53.1	49.1
Scraper	55	51
Scraper	55	51
Tractor/Loader/Backhoe	55.4	51.4
Tractor/Loader/Backhoe	55.4	51.4
Tractor/Loader/Backhoe	55.4	51.4
Tractor/Loader/Backhoe	55.4	51.4
Total	56.4	62.5

*Calculated Lmax is the Loudest value.

Roadway Construction Noise Model (RCNM),Version 1.1

Report date: 1/25/2021
 Case Description: Construction

Description Affected Land Use
 Construction Residential

Description	Impact Device	Usage(%)	Equipment		Receptor Distance (feet)
			Spec Lmax (dBA)	Actual Lmax (dBA)	
Crane	No	16		80.6	1342
Paver	No	50		77.2	1342
Paveing Equipment	No	20		89.5	1342
Paveing Equipment	No	20		89.5	1342
Pile Driver	Yes	20		101.3	1342
Pile Driver	Yes	20		101.3	1342
Pile Driver	Yes	20		101.3	1342
Pile Driver	Yes	20		101.3	1342
Roller	No	20		80	1342
Roller	No	20		80	1342
Rough Terrain Forklift	No	40		83.4	1342
Rough Terrain Forklift	No	40		83.4	1342
Rough Terrain Forklift	No	40		83.4	1342
Rough Terrain Forklift	No	40		83.4	1342
Tractor/Loader/Backhoe	No	40	84		1342
Tractor/Loader/Backhoe	No	40	84		1342
Tractor/Loader/Backhoe	No	40	84		1342
Tractor/Loader/Backhoe	No	40	84		1342
Trencher	No	50		80.4	1342

Calculated (dBA)

Equipment	*Lmax	Leq
Crane	52	44
Paver	48.6	45.6
Paveing Equipment	60.9	53.9
Paveing Equipment	60.9	53.9
Pile Driver	72.7	65.7
Pile Driver	72.7	65.7
Pile Driver	72.7	65.7
Pile Driver	72.7	65.7
Roller	51.4	44.4
Roller	51.4	44.4
Rough Terrain Forklift	54.8	50.8
Rough Terrain Forklift	54.8	50.8
Rough Terrain Forklift	54.8	50.8
Rough Terrain Forklift	54.8	50.8
Tractor/Loader/Backhoe	55.4	51.4
Tractor/Loader/Backhoe	55.4	51.4
Tractor/Loader/Backhoe	55.4	51.4
Tractor/Loader/Backhoe	55.4	51.4
Trencher	51.8	48.8
Total	72.7	72.2

*Calculated Lmax is the Loudest value.

SoundPLAN 3-D Noise Model Outputs – Project Onsite Noise

SoundPLAN
Output Source Information

Number	Receiver Name	Floor	Level at Receiver
1	Residence to the north	Ground Floor	32.4 dBA
2	Residence to the north	Ground Floor	32.0 dBA
3	Residence to the north	Ground Floor	29.5 dBA
4	Residence to the north	Ground Floor	27.3 dBA

Number	Noise Source Information	Citation	Level at Source
1	Noise Activity at Solar Facility	ECORP Consulting	47.1 dBA

Vega SES 4 Solar Energy Storage Project

TRAFFIC IMPACT STUDY
IMPERIAL COUNTY, CALIFORNIA

Prepared By:



December, 2021

Table of Contents

1.0 INTRODUCTION	5
PROJECT LOCATION	5
PROJECT DESCRIPTION	6
CONSTRUCTION ACTIVITIES.....	7
2.0 CAPACITY ANALYSIS METHODOLOGIES.....	7
STUDY AREA CRITERIA.....	7
SCENARIO CRITERIA	8
PEAK HOUR INTERSECTION LEVEL OF SERVICE STANDARDS.....	8
ROADWAY SEGMENT LEVEL OF SERVICE STANDARDS.....	9
FREEWAY SEGMENTS	9
ANALYSIS OF SIGNIFICANCE.....	10
3.0 EXISTING CONDITIONS	11
EXISTING ROADWAYS.....	11
TRAFFIC VOLUMES	13
EXISTING YEAR CONDITIONS	14
FREEWAY SEGMENT ANALYSIS	15
4.0 TRIP GENERATION/DISTRIBUTION/ASSIGNMENT.....	15
PROJECT TRIP GENERATION.....	15
TRIP DISTRIBUTION ASSIGNMENT.....	16
5.0 CONSTRUCTION YEAR CONDITIONS	17
SEGMENTS.....	20
INTERSECTIONS.....	20
FREEWAY SEGMENT ANALYSIS	21
6.0 CIRCULATION	22
PROJECT ACCESS AND CIRCULATION	22
PARKING.....	23
7.0 VEHICLE MILES TRAVELLED.....	23
8.0 IMPACTS AND MITIGATIONS	24

List of Figures

FIGURE 1.1: STUDY AREA	5
FIGURE 1.2: SITE PLAN	6
FIGURE 3.1: INTERSECTION GEOMETRICS	12
FIGURE 3.2: EXISTING VOLUMES	13
FIGURE 4.1: TRIP DISTRIBUTION	16
FIGURE 5.1: CONSTRUCTION YEAR VOLUMES.....	18
FIGURE 5.2: CONSTRUCTION YEAR PLUS PROJECT YEAR VOLUMES	19

List of Tables

TABLE 2.1: HCM LEVEL OF SERVICE DEFINITIONS FOR INTERSECTIONS	8
TABLE 2.2: COUNTY OF IMPERIAL ADT LEVEL OF SERVICE VOLUMES BY ROADWAY TYPE.....	9
TABLE 2.3: CALTRANS FREEWAY SEGMENT LEVEL OF SERVICE DEFINITIONS.....	10
TABLE 3.1: EXISTING YEAR CONDITIONS ROADWAY SEGMENT ANALYSIS	14
TABLE 3.2: EXISTING YEAR CONDITIONS PEAK HOUR INTERSECTION ANALYSIS	14
TABLE 3.3: EXISTING FREEWAY LEVEL OF SERVICE	15
TABLE 4.1: CONSTRUCTION TRIP GENERATION - CONSTRUCTION PHASE.....	15
TABLE 5.1: CONSTRUCTION YEAR ROADWAY SEGMENT ANALYSIS.....	20
TABLE 5.2: CONSTRUCTION YEAR PEAK HOUR INTERSECTION ANALYSIS.....	21
TABLE 5.3: CONSTRUCTION YEAR FREEWAY LEVEL OF SERVICE.....	21

APPENDICES

APPENDIX A: TRAFFIC COUNT DATA..... 25
APPENDIX B: EXISTING YEAR CONDITIONS ANALYSIS WORKSHEETS 46
APPENDIX C: NEAR TERM ANALYSIS WORKSHEETS..... 63
APPENDIX D: NEAR TERM WITH PROJECT ANALYSIS WORKSHEETS 80

1.0 Introduction

This traffic impact analysis (TIA) has been prepared to identify the potential traffic impacts associated with developing the Vega SES 4 Solar Energy Storage (Projects) in Imperial County. The study was completed following the guidelines described in the County of Imperial Department of Public Works *Traffic Study and Report Policy* dated March 12, 2007, revised June 29, 2007 and approved by the Board of Supervisors of the County of Imperial on August 7, 2007 ("Traffic Study and Report Policy").

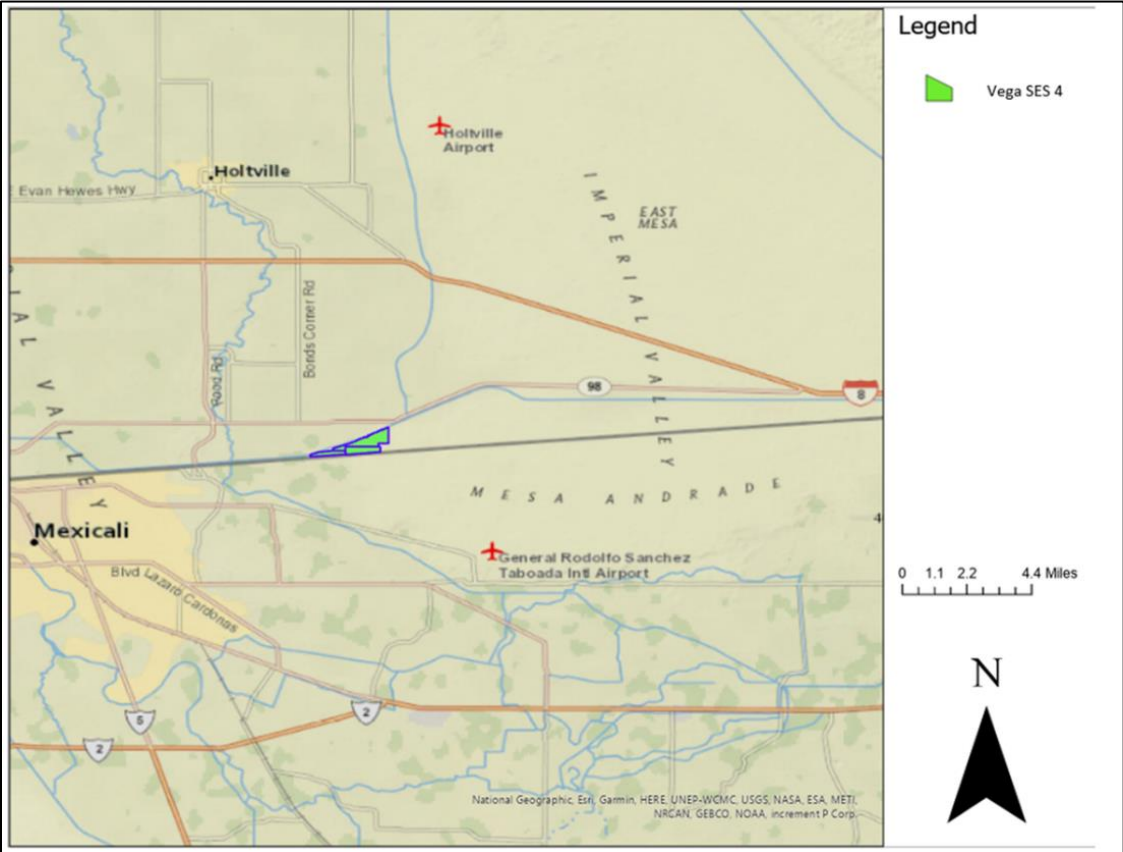
KOA has coordinated with the County's Engineering Department on the scope of the traffic analysis, including the study area and future year analysis assumptions. As necessary, if required, projects will be identified to offset or reduce significant impacts. Based on discussions with City staff, current and future traffic conditions at select intersections in close proximity to the proposed project have been evaluated for the purposes of this TIA.

This report describes the existing roadway network in the vicinity of the project site. It includes a review of the existing and proposed traffic activities for weekday peak AM and PM periods and daily traffic conditions.

Project Location

The project location is shown in Figure 1.1.

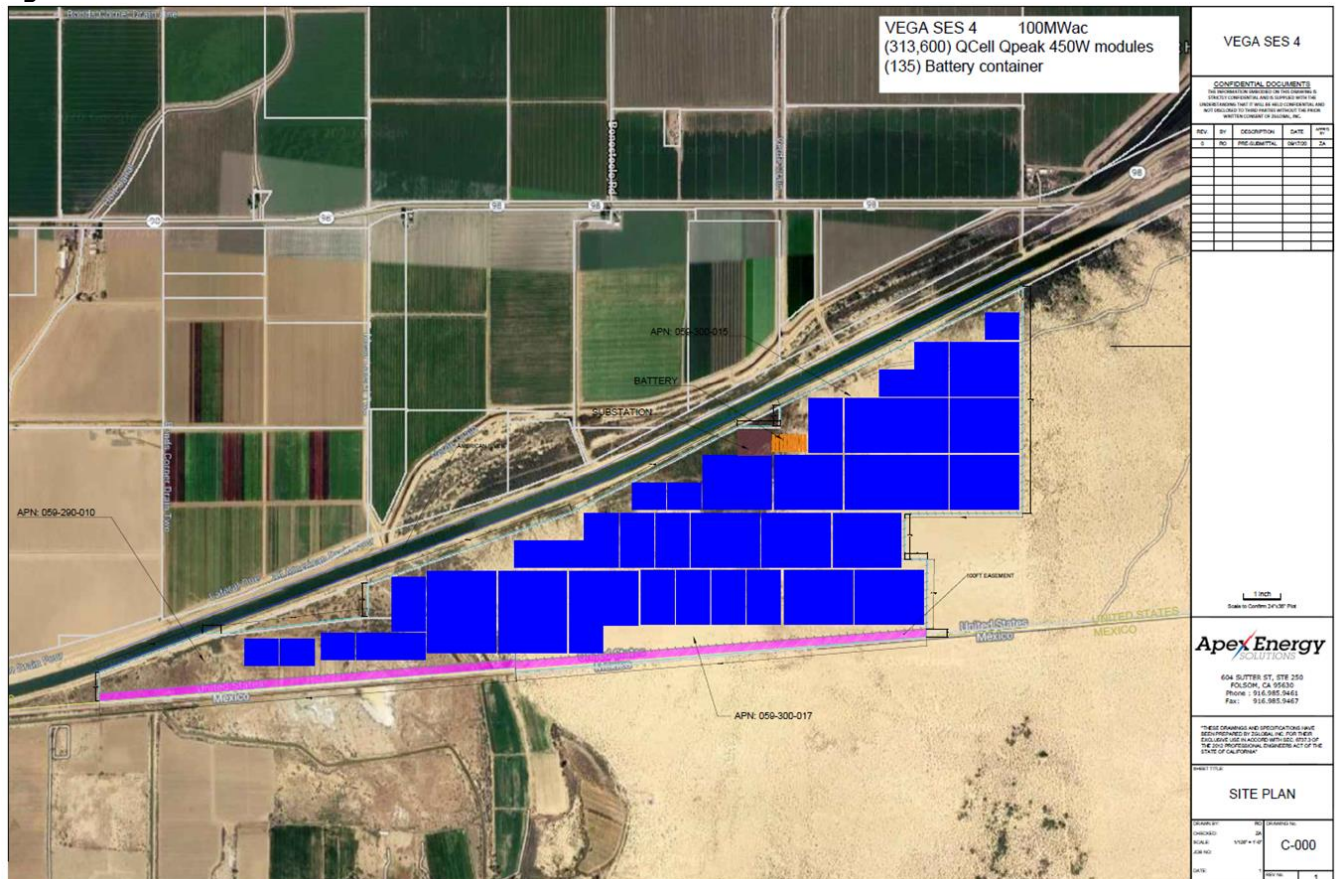
Figure 1.1 Study Area



Project Description

Vega SES 4 LLC. is proposing to develop the Vega SES 4 Solar Energy Storage Project (Projects). The project is a 100-megawatt alternating current (MWAC) solar photovoltaic (PV) energy generation project with an integrated 100 MW battery storage project on approximately 531.53 acres of land in the County of Imperial, California. The Project would be located between the California/Mexico border and the All-American Canal, on the California side. It is approximately 10 miles east of Calexico. The construction of the site is estimated to take 12-18 months and would begin in 2022. The project opening is anticipated to be 2023. The project site plan is shown in Figure 1.2.

Figure 1.2 Site Plan



Construction Activities

The construction of the site to include site preparation and construction is estimated to take 12-18 months and would begin in 2022. The number of on-site construction workers for the solar project facilities is not expected to exceed 150 workers at any one time. The number of on-site construction workers for the battery storage facility and the substation is not expected to exceed 100 workers at any one time.

Construction of the Projects will include the following activities:

- Site preparation
- Grading and earthwork
- Concrete foundations
- Structural steel work
- Electrical/instrumentation work
- Collector line installation
- Architecture and landscaping

2.0 Capacity Analysis Methodologies

This section presents a brief overview of traffic analysis methodologies and concepts used in this study. Street system operating conditions are typically described in terms of "level of service (LOS)" to compare without project and with project alternatives. LOS is a report-card scale used to indicate the quality of traffic flow on roadway segments and at intersections. The levels of service range from Level A (free flow, little congestion) to Level F (forced flow, higher congestion).

Study Area Criteria

The study area is determined based on the County of Imperial Department of Public Works *Traffic Study and Report Policy* dated March 12, 2007, revised June 29, 2007 and approved by the Board of Supervisors of the County of Imperial on August 7, 2007 ("Traffic Study and Report Policy"). "Any project that has the potential to degrade an existing road section, an existing signalized intersection, or an existing unsignalized intersection to below the existing level of service or to cause it to be lower than a level of service (LOS) "C" during any peak hour, using the HCM Methods of analysis on any individual, existing traffic movement." Traffic Study and Report Policy, 4-5.

The study area for this project includes those locations that likely will be affected by this project. The project study area was determined based on similar solar projects. The specific study area consists of the following intersections:

1. Site driveway and SR-98
2. Bonds Corner Road and SR-98
3. SR-98 and SR-7
4. SR-7 and Heber Road
5. SR-7 and south ramp
6. SR-7 and north ramp

The study area also includes the following study segments:

1. SR-98 from the project to the east
2. SR-98 from the project to Bonds Corner Road
3. SR-98 from Bonds Corner Road to SR-7
4. SR-7 from SR-98 to I-8
5. I-8 from SR-7 to SR-111

Scenario Criteria

The proposed project's traffic impacts were analyzed in three scenarios as listed below. The traffic analysis included intersections and roadway segments within Imperial County and Caltrans District 11 in the following scenarios to determine the potential impacts.

- Existing Year (2020) Conditions
- Construction Year (2023) Baseline Conditions
- Construction Year (2023) + Project Construction Conditions

Peak Hour Intersection Level of Service Standards

Traffic conditions on most roadway facilities are analyzed using the principles of the specific analysis methods contained in the latest version (2010) of the *Highway Capacity Manual (HCM)*, a publication of the Transportation Research Board, a research agency affiliated with the Federal Government. Chapter 18 of the *HCM 2010* is devoted to analysis of signalized intersections. The methodology in the *HCM 2010* for signalized intersections is based upon measurements or forecasts of control delay for traffic utilizing all approaches to the intersection.

Unsignalized intersections, including two-way and all-way stop controlled intersections were analyzed using the 2010 Highway Capacity Manual unsignalized intersection analysis methodology. The LOS for a two-way stop controlled (TWSC) intersection is determined by the computed or measured control delay and is defined for each minor movement. The analysis of peak hour intersection conditions was conducted using the Synchro 10 software program developed by Trafficware. Results are displayed in terms of control delay (seconds per vehicle) and an equivalent LOS as shown in Table 2.1.

Table 2.1: HCM Level of Service Definitions for Intersections

LOS	Signalized Intersection Delay (Seconds per Vehicle)	Unsignalized Intersection Average Stop Delay (Seconds)
A	<10	<10
B	>10 and <20	>10 and <15
C	>20 and <35	>15 and <25
D	>35 and <55	>25 and <35
E	>55 and <80	>35 and <50
F	>80	>50

Source: Highway Capacity Manual, 2010.

Roadway Segment Level of Service Standards

Roadway segment LOS standards and thresholds provide the basis for analysis of roadway segment performance. The analysis of roadway segment LOS is based on the functional classification of the roadway, the maximum capacity, roadway geometrics, and existing or forecast Average Daily Traffic (ADT) volumes.

The County of Imperial level of service analysis was performed by utilizing the *Circulation and Scenic Highways Element, January 2008*. The thresholds for each facility type are presented in Table 2.2.

Table 2.2 County of Imperial ADT Level of Service Volumes by Roadway Type

Road		Level of Service (LOS)				
Class	X-Section	A	B	C	D	E
Expressway	154/210	30,000	42,000	60,000	70,000	80,000
Prime Arterial	106/136	22,200	37,000	44,600	50,000	57,000
Minor Arterial	82/102	14,800	24,700	29,600	33,400	37,000
Major Collector	64/84	13,700	22,800	27,400	30,800	34,200
Minor (Local) Collector	40/70	1,900	4,100	7,100	10,900	16,200
<p>* Levels of service are not applied to residential streets since their primary purpose is to serve abutting lots, not carry through traffic. Levels of service normally apply to roads carrying through traffic between major trip generators and attractors.</p> <p>Source: <i>Imperial County Circulation and Scenic Highways Element 2008 and Imperial County Long Range Transportation Plan 2013 Update</i></p>						

Freeway Segments

Freeway level of service analysis is based upon procedures developed by Caltrans. The procedure for calculating freeway level of service involves calculating a peak hour volume to capacity (V/C) ratio. Peak hour volumes are calculated from Average Daily Traffic (ADT) volumes by applying design hour ("K"), directional ("D") and truck ("T") factors. The base capacities for Interstate 8 freeway lanes determined from the Highway Capacity Manual as assumed to be 2,350 passenger-car per hour per main lane (pc/h/ln).

The resulting V/C ratio is then compared to acceptable ranges of V/C values corresponding to the various levels of service for each facility classification, as shown in Table 2.3. The corresponding level of service represents an approximation of freeway operating conditions in the peak direction of travel during the peak hour. Constant with Caltrans requirements, LOS D or better is used in this study as the threshold for acceptable freeway operations.

Table 2.3 CALTRANS Level of Service Facility Classification

CALTRANS FREEWAY SEGMENT LEVEL OF SERVICE DEFINITIONS			
LOS	Maximum V/C	Congestion/Delay	Traffic Description
A	≤ 0.30	None	Free flow.
B	> 0.30 - 0.50	None	Free to stable flow, light to moderate volumes.
C	> 0.50 - 0.71	None to minimal	Stable flow, moderate volumes, freedom to maneuver noticeably restricted.
D	> 0.71 - 0.89	Minimal to substantial	Approaches unstable flow, heavy volumes, very limited freedom to maneuver.
E	> 0.89 - 1.00	Significant	Extremely unstable flow, maneuverability and psychological comfort extremely poor.
F	> 1.00	Considerable	Forced or breakdown flow. Delay measured in average travel speed (MPH). Signalized segments experience delays >60.0 seconds/vehicle.

Source: Caltrans Guide for the Preparation of Traffic Impact Studies, 2002.

Analysis of Significance

Imperial County

The significance criteria for traffic impacts are based on the Imperial County Planning & Development Services Department LOS standard as outlined in the "Circulation Element". The County's goal for an acceptable traffic service standard on an Average Daily Traffic (ADT) basis and during AM and PM peak periods for all County-Maintained Roads shall be LOS C for all street segment links and intersections.

- Strive to maintain LOS "C" or better on arterial and collector streets, at all intersections, and on principal arterials during the hour of highest volume during the AM hours and also during the PM hours. Imperial County has established LOS "C" as the general threshold for acceptable overall traffic operations for both signalized and un-signalized intersections.
- Accept LOS "D" after finding that there is no practical and feasible way to mitigate to LOS "C;" and the development causing the lower level of service provides a clear, overall public benefit.
- For segments that operate at LOS D or lower, an incremental increase in v/c of greater than 0.02 is considered to be a significant impact. For intersections that operate at LOS D or lower, an incremental increase in vehicle delay of 2.0 seconds or greater is considered to be a significant impact.

Caltrans

- For segments that operate at LOS D or lower, an incremental increase in v/c of greater than 0.02 is considered to be a significant impact. For intersections that operate at LOS D or lower, an incremental increase in vehicle delay of 2.0 seconds or greater is considered to be a significant impact.
- For freeway segments that operate at LOS D or lower, an incremental increase in v/c of greater than 0.01 is considered to be a significant impact.

3.0 Existing Conditions

This section documents the Existing Year Conditions in the study area. The Existing Year is taken to be 2020 for analysis purposes based on existing traffic counts taken in December, 2020. The discussion presented here is limited to segments and intersections in the project's vicinity.

Existing Roadways

Each of the key roadways, as well as associated study intersections within the study area, are discussed below.

Roadway Facilities

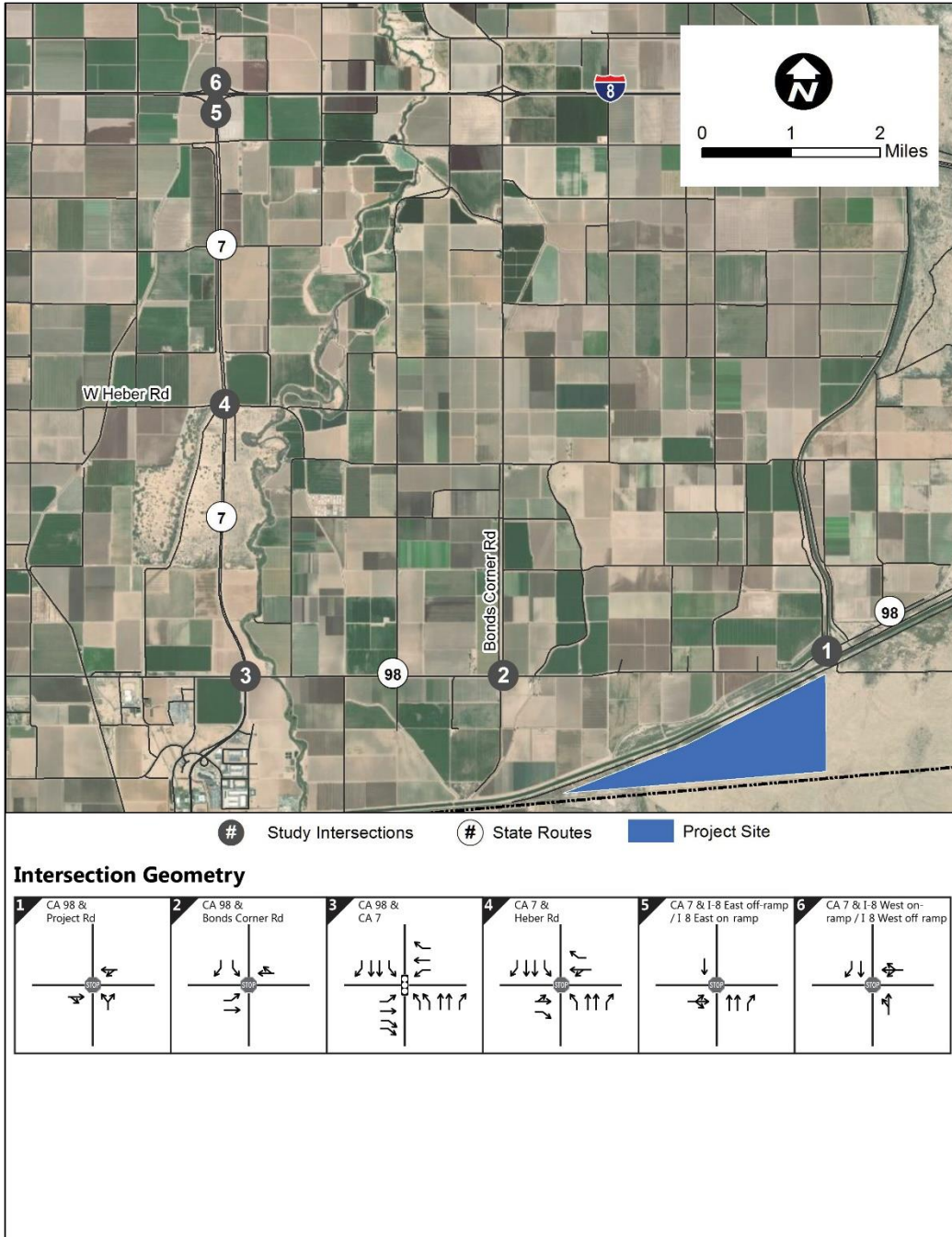
State Route 98 (SR-98) is a two-lane highway with no median and a posted speed limit of 65 mph.

State Route 7 (SR-7) is a four-lane highway with median and a posted speed limit of 65 mph between SR-98 and I-8.

Interstate 8 (I-8) is a four-lane divided freeway with two (2) lanes in each direction with a posted speed limit of 70 mph.

Figure 3.1 displays the existing intersection geometrics for study area intersections.

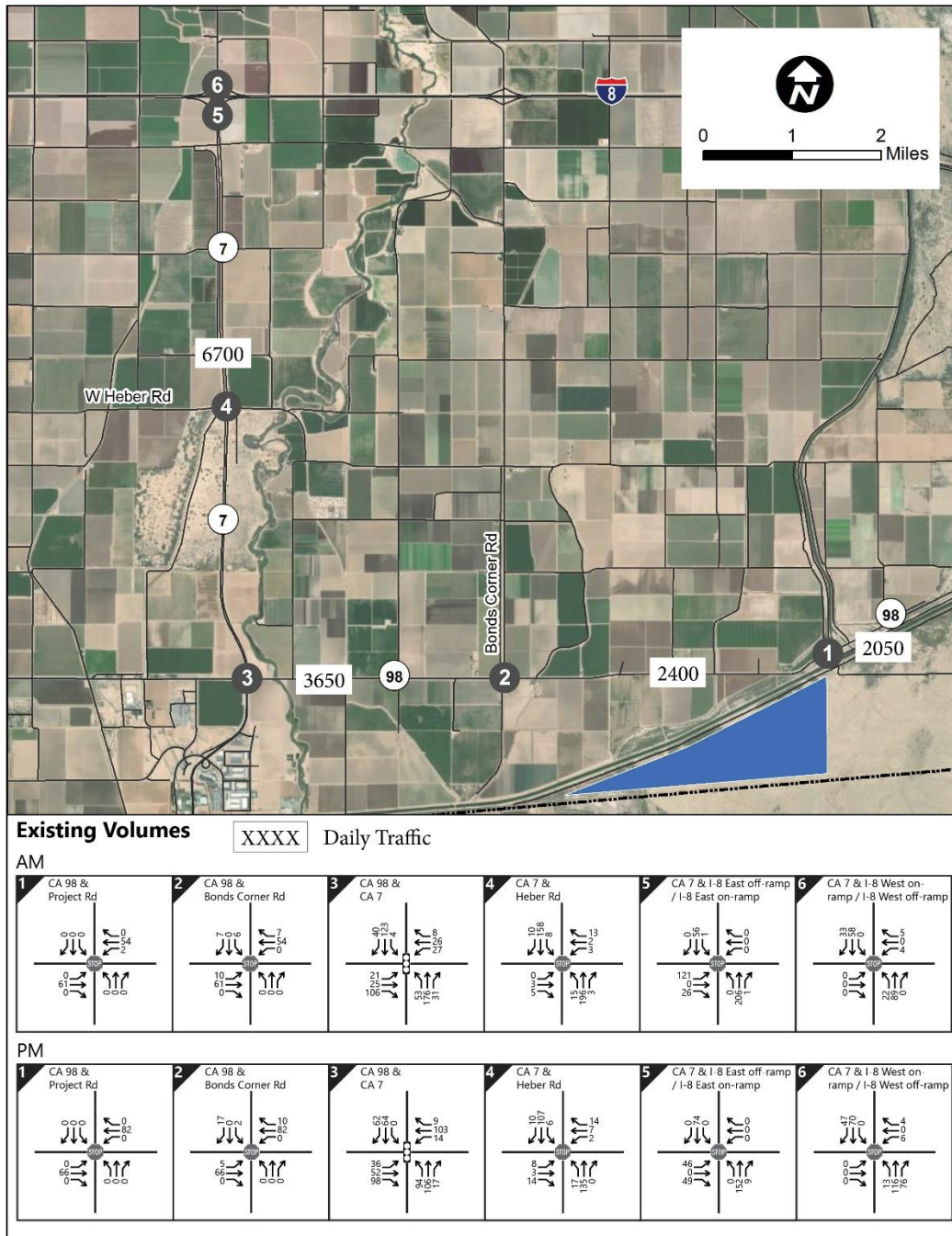
Figure 3.1. Intersection Geometrics



Traffic Volumes

Existing turning movement counts at the study intersections were conducted on Tuesday, December 8, 2020. The existing condition reflects those land uses that were built and occupied at the time of the traffic counts and represent a typical weekday commute period. Intersection turning movement counts are provided in Appendix A. Existing average daily traffic (ADT) segment counts were obtained from the Caltrans for the year 2019. The ADT and weekday a.m. and p.m. peak hour traffic volumes are shown on Figure 3.2.

Figure 3.2. Existing Volumes



Existing Year Conditions

This section documents the existing traffic conditions of study area segments and intersections.

Segments

Roadway segment analysis was conducted for the study area's specified segments. Using average daily traffic (ADT) counts, KOA was able to determine the existing level of service for the designated roadway segments. Table 3.1 below displays these levels of service.

Table 3.1 Existing Year Conditions Roadway Segment Analysis

Roadway Segment	From/ To	Lanes/ Class	LOS E Capacity	Existing		
				ADT	V/C	LOS
SR-98	Project to east	Minor Arterial 2 Lane	18,500	2,050	0.11	A
SR-98	Project to Bonds Corner	Minor Arterial 2 Lane	18,500	2,400	0.13	A
SR 98	Bonds Corner to SR-7	Minor Arterial 2 Lane	18,500	3,650	0.20	A
SR-7	SR-98 to I-8	Principal Arterial 4 Lane	57,000	6,700	0.12	A

Intersections

An intersection LOS analysis was prepared for the existing condition and is summarized in Table 3.2 which indicates that there are two study area intersections. Detailed LOS worksheets are included in Appendix B.

Table 3.2: Existing Year Conditions Peak Hour Intersection Analysis

#	Intersection	Control	AM Peak Hour		PM Peak Hour	
			Delay	LOS	Delay	LOS
1	Site Driveway/ SR-98	NB Stop	0	A	0	A
2	SR-98 / Bonds Corner	SB Stop	8.9	A	8.9	A
3	SR-98 / SR-7	Signal	8.6	A	8.7	A
4	SR-7 / Heber Road	EB/WB Stop	10.1	B	9.6	A
5	SR -7 / I-8 So. Ramps	EB Stop	10.3	B	9.5	A
6	SR-7 / I-8 North Ramps	WB Stop	9.3	A	9.9	A

Delay is in seconds/vehicle. LOS = Level of Service

Freeway Segment Analysis

Table 3.3 displays the freeway segment level of service analysis results under existing conditions.

Table 3.3 Existing Freeway Level of Service

Freeway	Segment	ADT (a)	Peak Direction	# of Lanes	Capacity (b)	D	K	HVF	PK Vol	V/C	LOS
I-8	SR-7 to SR-111	19,700	EB (AM)	2	4,700	11	57	23	1,519	0.32	B
			WB (PM)	2	4700	11	59	23	1,563	0.33	B

- a. Traffic volumes provided by Caltrans (2019)
- b. The capacity is calculated as 2,350 per hour/ per main lane
- c. D = Directional split,| K = Peak hour %
- d. HVF = Heavy vehicle %. These values were obtained from Caltrans peak hour volume data (2019)
- e. PK Vol – highest hourly directional volume

4.0 Trip Generation/Trip Distribution

Project Trip Generation

The project trip generation consists of a construction phase and operations phase. Once constructed, the site will not require personnel to be present on-site and will not result in daily trip generation. For this reason, only the trip generation for the construction phase was analyzed.

The construction of the site is estimated to take 12-18 months and would begin in 2022. The number of on-site construction workers for the solar project facilities is not expected to exceed 150 workers at any one time. The number of on-site construction workers for the battery storage facility and the substation is not expected to exceed 100 workers at any one time. The trip generation was estimated if the construction phases were to overlap, so both are included. Delivery trucks are expected to follow the same routes as the construction workers. An estimated two trucks would arrive at the project site each day during the first few weeks of construction of the solar generating facility. Truck trips have been converted into passenger equivalent volumes (PCE) using a PCE factor of 2.5.

Work hours will be between the hours of 8:00 a.m. and 5:00 p.m. Monday through Saturday. The trips generated during the construction phase of construction are shown in Table 4.1.

Table 4.1 Construction Trip Generation – Construction Phase

	Intensity	Unit	Daily Rate (1)	Daily Trips		AM Peak Hour			PM Peak Hour		
						Total	In	Out	Total	In	Out
Solar Construction Workers	150.0	Employee	2	300	Rate	1.00	100%	0%	1.00	0%	100%
					Trips	150	150	0	150	0	150
Battery Storage Workers	100.0	Employee	2	200	Rate	1.00	100%	0%	1.00	0%	100%
					Trips	100	100	0	100	0	100
Construction Truck Trips (PCE)	8.0	Trucks	2.5	20	Rate	0.13	75%	25%	0.13	25%	75%
					Trips	3	2	1	3	1	2
Total				520	Trips	253	252	1	253	1	252

Trip Distribution and Assignment

Trip distribution and assignment is the process of identifying the probable destinations, directions, and traffic routes that project related traffic will likely affect. Trip distribution and assignment information can be estimated from observed traffic patterns, experience or through use of a computerized travel forecast model. Once the proposed developments trips have been estimated, they are assigned to the study area street network. The trip distribution was estimated based on using logical travel paths between the project and local origins. The trip distribution for the project-related trips is shown in Figure 4.1.

Figure 4.1 Trip Distribution



The trip distribution for heavy trucks would require crossing the All America Canal at Gordon Wells Drive. It is estimated that 90% of heavy trucks will travel to the site on eastbound I-8 to the Gordon Wells Drive interchange. The remaining 10% will travel on I-8 westbound. As shown in Table 4.1, only 8 truck trips per day are estimated to use this route.

5.0 Construction Year Conditions

This section documents the analysis for the Project Completion Year conditions. This scenario considers the traffic conditions at the time that the proposed development is constructed by increasing the existing traffic counts by an ambient growth rate to reflect cumulative projects. Projected project only volumes are then added to create the 2023 Baseline with Project Scenario. It is anticipated that the project will be completed in Year 2023. An annual ambient growth of 1.8% was utilized to account for traffic growth between 2020 and 2023.

The growth rate is based on the California Economic Forecast *California County-Level Economic Forecast 2017-2050*, dated September 2017 documents an average annual growth factor of 1.8 percent from 2020 to 2025 for Imperial County. Year 2021 traffic data was obtained by factoring the 2019 traffic counts by the application of the 1.8 percent annual growth (5.4 percent for 2020-23). Figure 5.1 illustrates the Project Construction Year background volumes. Figure 5.2 shows the *Construction Year with Project* traffic volumes in the study area.

This section documents the construction year traffic conditions of study area segments and intersections with and without the project.

Figure 5.1 Construction Year Volumes

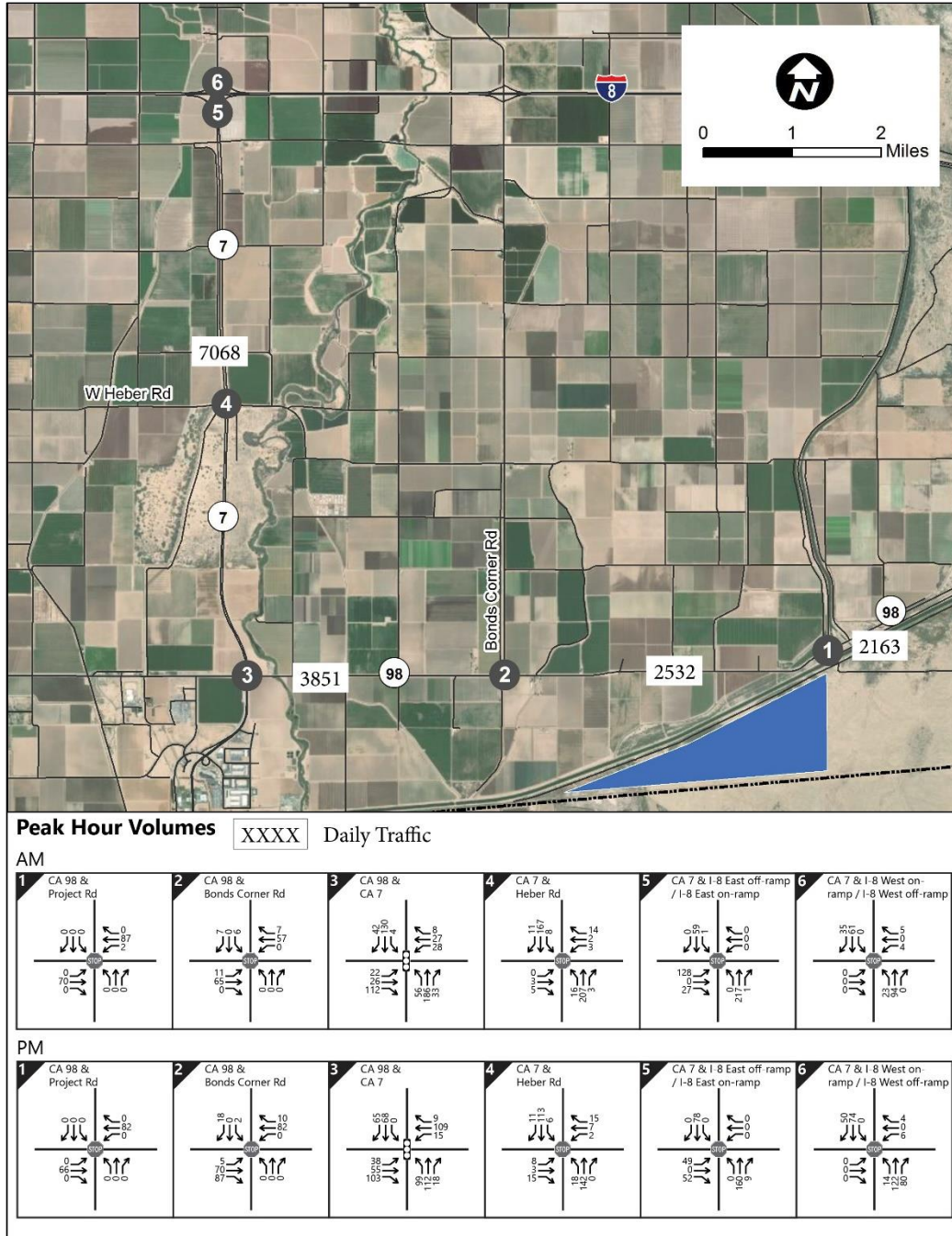
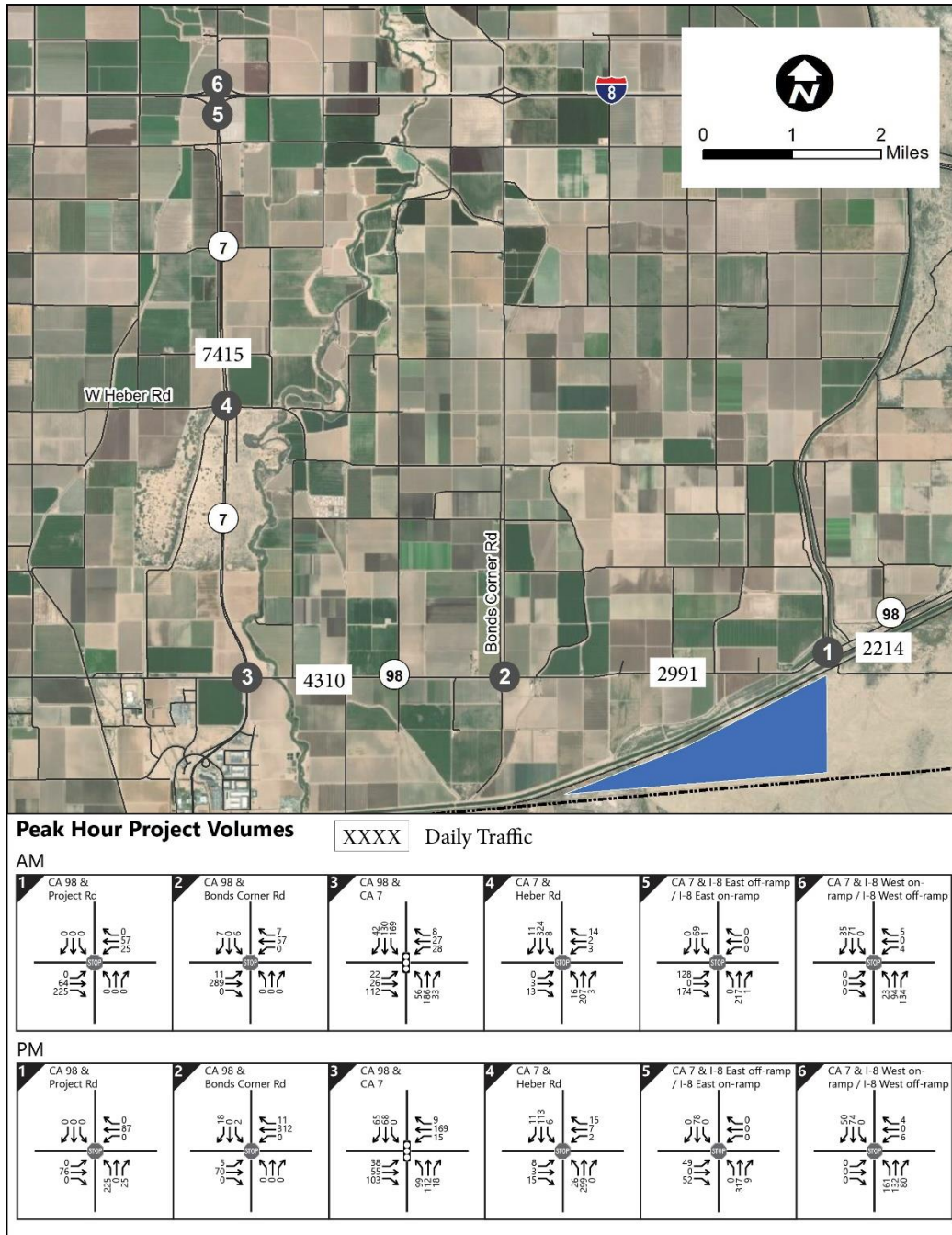


Figure 5.2 Construction Year Plus Project Year Volumes



Segments

Roadway segment analysis was conducted for the study area's specified segments. Using average daily traffic (ADT) counts, KOA determined the opening year level of service for the designated roadway segments.

Summarized in Table 5.1 are Construction Year and Construction Year plus Project roadway segment average daily traffic volumes and their associated LOS on route segments without and with the project under the near term condition. All roadway segments would operate at LOS B or better with and without the project. Therefore, the project would not result in any significant impacts to any segments within the project study area under the construction year condition.

Table 5.1 Construction Year Roadway Segment Analysis

No.	Route	From/To	Lanes/ Class	LOS E Capacity	Project Volumes	Construction Year			Construction Year + Project			Comparison	
						Volume	V/C	LOS	Volume	V/C	LOS	Δ V/C	Sig?
1	SR-98	Project to east	Minor Arterial 2 Lane	18,500	51	2,163	0.12	A	2,214	0.12	A	0.00	No
2	SR-98	Project to Bonds Corner	Minor Arterial 2 Lane	18,500	459	2,532	0.14	A	2,991	0.16	A	0.02	No
3	SR 98	Bonds Corner to SR-7	Minor Arterial 2 Lane	18,500	459	3,851	0.21	A	4,310	0.23	A	0.02	No
4	SR-7	SR-98 to I-8	Principal Arterial 4 Lane	57,000	347	7,068	0.12	A	7,415	0.13	A	0.01	No

Intersections

Table 5.2 summarizes the LOS at each intersection during the AM and PM peak hours under the construction year condition in 2022, without and with the project volumes. The estimated change in project delay associated with the project is also reported. All intersections would operate at a LOS C or better during both AM and PM peak hours with and without the project. Therefore, the project would not result in any significant impacts to any intersections within the project study area under the construction year condition. Detailed LOS worksheets for the Construction Year are included in Appendix C and for the Construction Year plus Project in Appendix D.

Table 5.2 Construction Year Peak Hour Intersection Analysis

No.	Intersection	Control	Construction Year		Construction Year + Project		Change Delay	Significant
			Delay	LOS	Delay	LOS		
AM Peak Hour between 7:00 to 9:00 a.m.								
1	Site Driveway/ SR-98	NB Stop	n/a	A	0.0	A	n/a	N
2	SR-98 / Bonds Corner	SB Stop	9.0	A	9.8	A	0.8	N
3	SR-98 / SR-7	Signal	8.7	A	9.4	A	0.7	N
4	SR-7 / Heber Road	EB/WB Stop	10.2	B	10.3	B	0.1	N
5	SR -7 / I-8 So. Ramps	EB Stop	10.5	B	11.4	B	0.9	N
6	SR-7 / I-8 North Ramps	WB Stop	9.8	A	9.8	A	0.0	N
PM Peak Hour between 4:00 to 6:00 p.m.								
1	Site Driveway/ SR-98	NB Stop	n/a	A	11.4	A	n/a	N
2	SR-98 / Bonds Corner	SB Stop	9.0	A	10.4	A	1.4	N
3	SR-98 / SR-7	Signal	8.8	A	9.0	A	0.5	N
4	SR-7 / Heber Road	EB/WB Stop	9.6	A	10.8	B	1.2	N
5	SR -7 / I-8 So. Ramps	EB Stop	10.0	B	10.0	B	0.0	N
6	SR-7 / I-8 North Ramps	WB Stop	12.6	B	12.6	B	0.0	N

Delay is in seconds/vehicle. LOS = Level of Service

Freeway Segment Analysis

Table 5.3 displays the freeway segment level of service analysis results for the Construction Year and for Construction Year plus Project. This freeway segment would operate at LOS B or better with and without the project. Therefore, the project would not result in any significant impacts to any segments within the project study area under the construction year condition.

Table 5.3 Construction Year Freeway Level of Service

Freeway	Segment	Peak Direction	V/C		Construction Year + Proj		Change V/C	Sig?
			V/C	LOS	V/C	LOS		
I-8	SR-7 to SR-111	EB (AM)	0.34	B	0.39	B	0.05	N
		WB (PM)	0.35	B	0.40	B	0.05	N

6.0 Circulation

The following section discusses the proposed project's access and circulation characteristics.

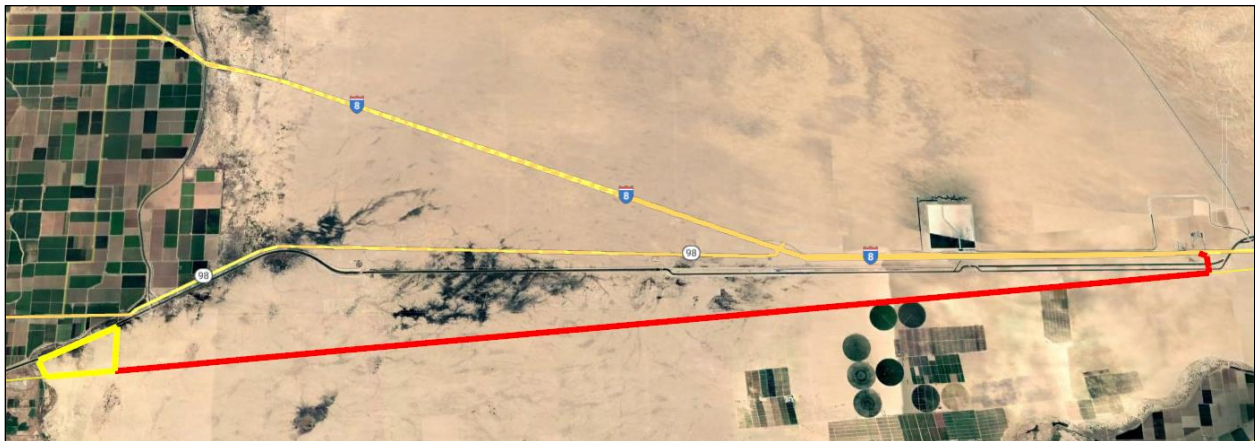
Project Access and Circulation

Access to and from the site will be provided from an existing driveway along SR 98. This will be the primary driveways serving the site. The volumes associated with the development are such that peak hour volumes do not warrant the need for additional storage lanes or storage length for entrances along SR 98. Vehicle storage for vehicles exiting the property will be on-site.

Access for heavy vehicles to and from the site requires crossing the All America Canal which is located parallel and just south of SR-98. Following discussions with the Imperial Irrigation District, it was determined heavy vehicles would cross the canal at Gordon Wells Road located 19 miles east of the project. Gordon Wells Road has an interchange with I-8. The bridge over the Canal was inspected in 2018. The report states that the bridges over the canal were constructed in 2009. The bridge is rated as open with no restrictions. The bridge condition is rated as "Good". The bridge sufficiency rating is 91.9.



Primary Access (located just east of site)



Access at Gordon Wells Road for heavy vehicles



Bridge over north American Canal



Bridge over south American Canal

Parking

The existing parking demand for up to 250 vehicles and for construction equipment will be provided on site.

7.0 Vehicle Miles Travelled

Senate Bill 743 (SB 743) was approved by California legislature in September 2013. SB 743 requires changes to California Environmental Quality Act (CEQA), specifically directing the Governor's Office of Planning and Research (OPR) to develop alternative metrics to the use of vehicular "Level of Service" (LOS) for evaluating transportation projects. OPR has prepared a technical advisory ("OPR Technical Advisory") for evaluating transportation impacts in CEQA and has recommended that Vehicle Miles Traveled (VMT) replace LOS as the primary measure of transportation impacts. The Natural Resources Agency has adopted updates to

CEQA Guidelines to incorporate SB 743 that requires VMT for the purposes of determining a significant transportation impact under CEQA.

Below, are three options for screening projects from project-level assessment as per the OPR guidelines, Technical Advisory on Evaluating Transportation Impacts in CEQA.

Step 1: Transit Priority Area (TPA) Screening

Step 2: Low VMT Area Screening

Step 3: Project Type Screening – yes exempt

Projects generating less than 110 daily vehicle trips. The proposed solar farm project, when constructed, will generate 10 or less daily trips. Based on this criteria, the project can be presumed to have a less than significant impact.

8.0 Impacts and Mitigation

This traffic impact analysis (TIA) has been prepared to identify the potential traffic impacts associated with constructing a solar photovoltaic (PV) energy generation project and utility-scale battery energy storage system (BESS).

The construction of the project is estimated to take 12-18 months and would begin in 2022. During the construction phase, at peak construction, for the time when both the PV and BESS project phases are being constructed as the same time, the project is anticipated to generate a maximum of 520 trip ends per day with 253 AM peak hour trips and 253 PM peak hour trips. Following construction, the project will not generate additional daily or peak hour trips beyond occasional maintenance. The project opening is anticipated to be 2023.

The project is not expected to create significant impacts at study intersections or study segments, therefore no mitigation measures are required. All study intersections and segments were found to operate at LOS C or better for all of the traffic scenarios analyzed.

APPENDIX A: TRAFFIC COUNT DATA

County of Imperial
 N/S: Bonds Corner Road
 E/W: SR-98
 Weather: Clear

File Name : 01_CIM_Bonds Corner_SR98 AM
 Site Code : 04120461
 Start Date : 12/8/2020
 Page No : 1

Groups Printed- Total Volume

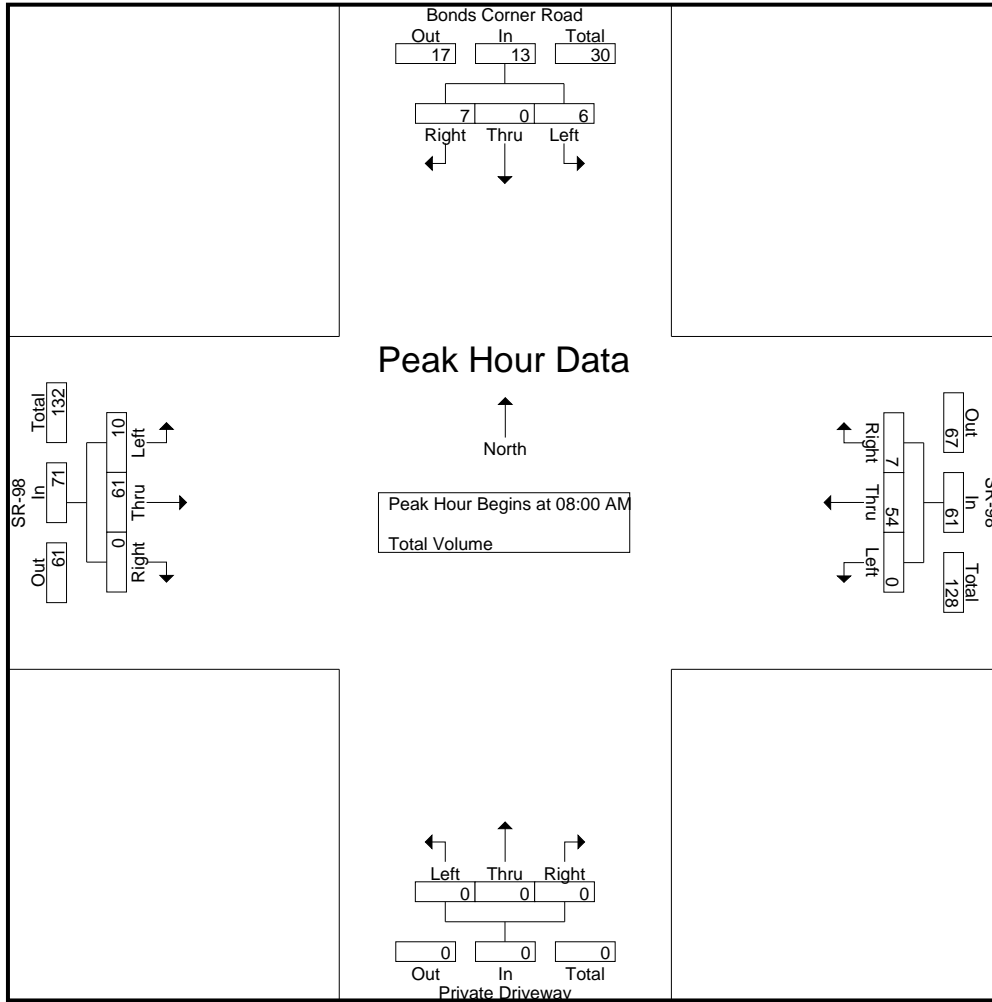
Start Time	Bonds Corner Road Southbound				SR-98 Westbound				Private Driveway Northbound				SR-98 Eastbound				Int. Total
	Left	Thru	Right	App. Total	Left	Thru	Right	App. Total	Left	Thru	Right	App. Total	Left	Thru	Right	App. Total	
07:00 AM	4	0	2	6	0	16	1	17	0	0	0	0	0	12	0	12	35
07:15 AM	0	0	1	1	0	14	2	16	0	0	0	0	0	10	0	10	27
07:30 AM	2	0	2	4	0	11	2	13	0	0	1	1	0	9	0	9	27
07:45 AM	1	0	0	1	0	16	1	17	0	0	0	0	1	11	0	12	30
Total	7	0	5	12	0	57	6	63	0	0	1	1	1	42	0	43	119
08:00 AM	1	0	4	5	0	11	2	13	0	0	0	0	2	15	0	17	35
08:15 AM	1	0	1	2	0	13	1	14	0	0	0	0	1	15	0	16	32
08:30 AM	1	0	2	3	0	17	3	20	0	0	0	0	2	11	0	13	36
08:45 AM	3	0	0	3	0	13	1	14	0	0	0	0	5	20	0	25	42
Total	6	0	7	13	0	54	7	61	0	0	0	0	10	61	0	71	145
Grand Total	13	0	12	25	0	111	13	124	0	0	1	1	11	103	0	114	264
Apprch %	52	0	48		0	89.5	10.5		0	0	100		9.6	90.4	0		
Total %	4.9	0	4.5	9.5	0	42	4.9	47	0	0	0.4	0.4	4.2	39	0	43.2	

Start Time	Bonds Corner Road Southbound				SR-98 Westbound				Private Driveway Northbound				SR-98 Eastbound				Int. Total
	Left	Thru	Right	App. Total	Left	Thru	Right	App. Total	Left	Thru	Right	App. Total	Left	Thru	Right	App. Total	
08:00 AM	1	0	4	5	0	11	2	13	0	0	0	0	2	15	0	17	35
08:15 AM	1	0	1	2	0	13	1	14	0	0	0	0	1	15	0	16	32
08:30 AM	1	0	2	3	0	17	3	20	0	0	0	0	2	11	0	13	36
08:45 AM	3	0	0	3	0	13	1	14	0	0	0	0	5	20	0	25	42
Total Volume	6	0	7	13	0	54	7	61	0	0	0	0	10	61	0	71	145
% App. Total	46.2	0	53.8		0	88.5	11.5		0	0	0		14.1	85.9	0		
PHF	.500	.000	.438	.650	.000	.794	.583	.763	.000	.000	.000	.000	.500	.763	.000	.710	.863

Peak Hour Analysis From 07:00 AM to 08:45 AM - Peak 1 of 1
 Peak Hour for Entire Intersection Begins at 08:00 AM

County of Imperial
 N/S: Bonds Corner Road
 E/W: SR-98
 Weather: Clear

File Name : 01_CIM_Bonds Corner_SR98 AM
 Site Code : 04120461
 Start Date : 12/8/2020
 Page No : 2



Peak Hour Analysis From 07:00 AM to 08:45 AM - Peak 1 of 1
 Peak Hour for Each Approach Begins at:

	08:00 AM				07:45 AM				07:00 AM				08:00 AM			
+0 mins.	1	0	4	5	0	16	1	17	0	0	0	0	2	15	0	17
+15 mins.	1	0	1	2	0	11	2	13	0	0	0	0	1	15	0	16
+30 mins.	1	0	2	3	0	13	1	14	0	0	1	1	2	11	0	13
+45 mins.	3	0	0	3	0	17	3	20	0	0	0	0	5	20	0	25
Total Volume	6	0	7	13	0	57	7	64	0	0	1	1	10	61	0	71
% App. Total	46.2	0	53.8		0	89.1	10.9		0	0	100		14.1	85.9	0	
PHF	.500	.000	.438	.650	.000	.838	.583	.800	.000	.000	.250	.250	.500	.763	.000	.710

County of Imperial
 N/S: Bonds Corner Road
 E/W: SR-98
 Weather: Clear

File Name : 01_CIM_Bonds Corner_SR98 PM
 Site Code : 04120461
 Start Date : 12/8/2020
 Page No : 1

Groups Printed- Total Volume

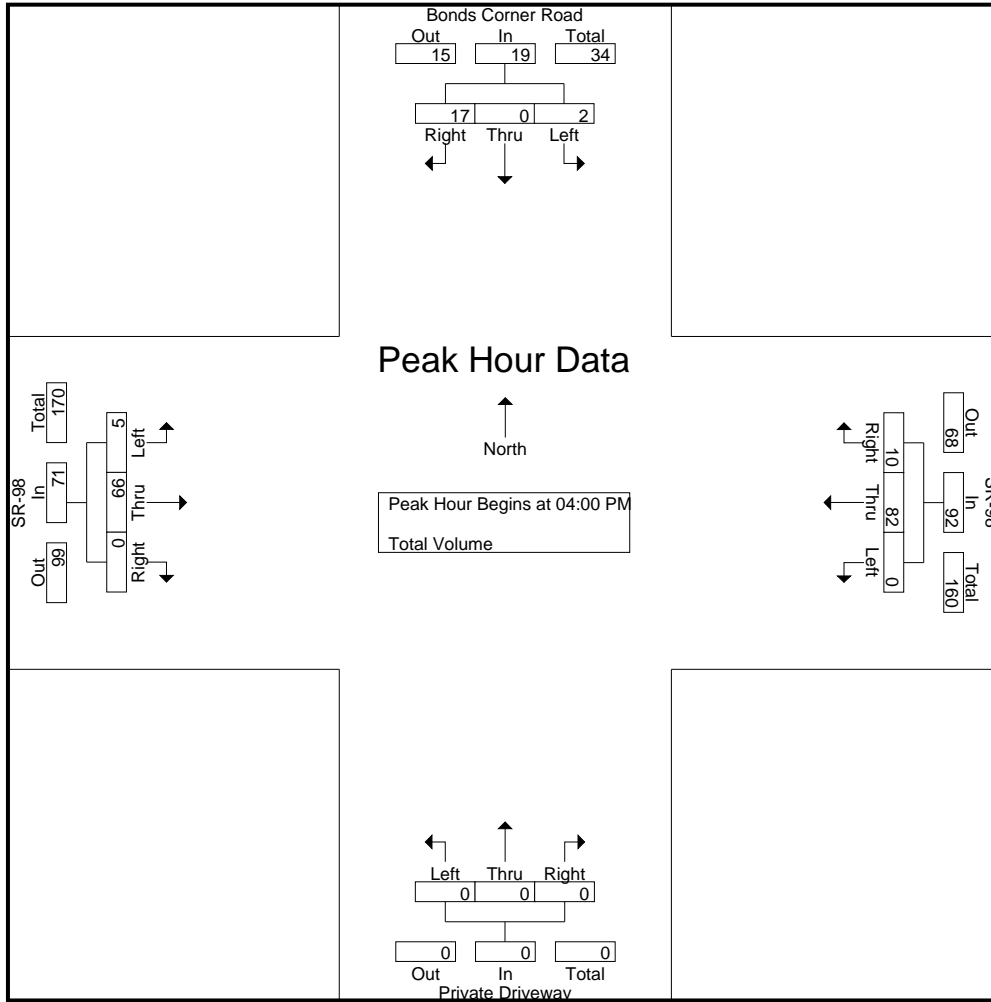
Start Time	Bonds Corner Road Southbound				SR-98 Westbound				Private Driveway Northbound				SR-98 Eastbound				Int. Total
	Left	Thru	Right	App. Total	Left	Thru	Right	App. Total	Left	Thru	Right	App. Total	Left	Thru	Right	App. Total	
04:00 PM	1	0	7	8	0	30	2	32	0	0	0	0	1	25	0	26	66
04:15 PM	0	0	6	6	0	13	2	15	0	0	0	0	1	12	0	13	34
04:30 PM	0	0	3	3	0	23	4	27	0	0	0	0	1	13	0	14	44
04:45 PM	1	0	1	2	0	16	2	18	0	0	0	0	2	16	0	18	38
Total	2	0	17	19	0	82	10	92	0	0	0	0	5	66	0	71	182
05:00 PM	0	0	2	2	0	27	0	27	0	0	0	0	0	13	0	13	42
05:15 PM	1	0	1	2	0	16	0	16	0	0	0	0	0	14	0	14	32
05:30 PM	0	0	2	2	0	25	1	26	0	0	0	0	0	27	0	27	55
05:45 PM	0	0	3	3	0	28	0	28	0	0	0	0	0	9	0	9	40
Total	1	0	8	9	0	96	1	97	0	0	0	0	0	63	0	63	169
Grand Total	3	0	25	28	0	178	11	189	0	0	0	0	5	129	0	134	351
Apprch %	10.7	0	89.3		0	94.2	5.8		0	0	0		3.7	96.3	0		
Total %	0.9	0	7.1	8	0	50.7	3.1	53.8	0	0	0	0	1.4	36.8	0	38.2	

Start Time	Bonds Corner Road Southbound				SR-98 Westbound				Private Driveway Northbound				SR-98 Eastbound				Int. Total
	Left	Thru	Right	App. Total	Left	Thru	Right	App. Total	Left	Thru	Right	App. Total	Left	Thru	Right	App. Total	
04:00 PM	1	0	7	8	0	30	2	32	0	0	0	0	1	25	0	26	66
04:15 PM	0	0	6	6	0	13	2	15	0	0	0	0	1	12	0	13	34
04:30 PM	0	0	3	3	0	23	4	27	0	0	0	0	1	13	0	14	44
04:45 PM	1	0	1	2	0	16	2	18	0	0	0	0	2	16	0	18	38
Total Volume	2	0	17	19	0	82	10	92	0	0	0	0	5	66	0	71	182
% App. Total	10.5	0	89.5		0	89.1	10.9		0	0	0		7	93	0		
PHF	.500	.000	.607	.594	.000	.683	.625	.719	.000	.000	.000	.000	.625	.660	.000	.683	.689

Peak Hour Analysis From 04:00 PM to 05:45 PM - Peak 1 of 1
 Peak Hour for Entire Intersection Begins at 04:00 PM

County of Imperial
 N/S: Bonds Corner Road
 E/W: SR-98
 Weather: Clear

File Name : 01_CIM_Bonds Corner_SR98 PM
 Site Code : 04120461
 Start Date : 12/8/2020
 Page No : 2



Peak Hour Analysis From 04:00 PM to 05:45 PM - Peak 1 of 1
 Peak Hour for Each Approach Begins at:

	04:00 PM				05:00 PM				04:00 PM				04:45 PM			
+0 mins.	1	0	7	8	0	27	0	27	0	0	0	0	2	16	0	18
+15 mins.	0	0	6	6	0	16	0	16	0	0	0	0	0	13	0	13
+30 mins.	0	0	3	3	0	25	1	26	0	0	0	0	0	14	0	14
+45 mins.	1	0	1	2	0	28	0	28	0	0	0	0	0	27	0	27
Total Volume	2	0	17	19	0	96	1	97	0	0	0	0	2	70	0	72
% App. Total	10.5	0	89.5		0	99	1		0	0	0		2.8	97.2	0	
PHF	.500	.000	.607	.594	.000	.857	.250	.866	.000	.000	.000	.000	.250	.648	.000	.667

County of Imperial
 N/S: SR-7
 E/W: SR-98
 Weather: Clear

File Name : 02_CIM_SR-7_SR98 AM
 Site Code : 04120461
 Start Date : 12/8/2020
 Page No : 1

Groups Printed- Total Volume

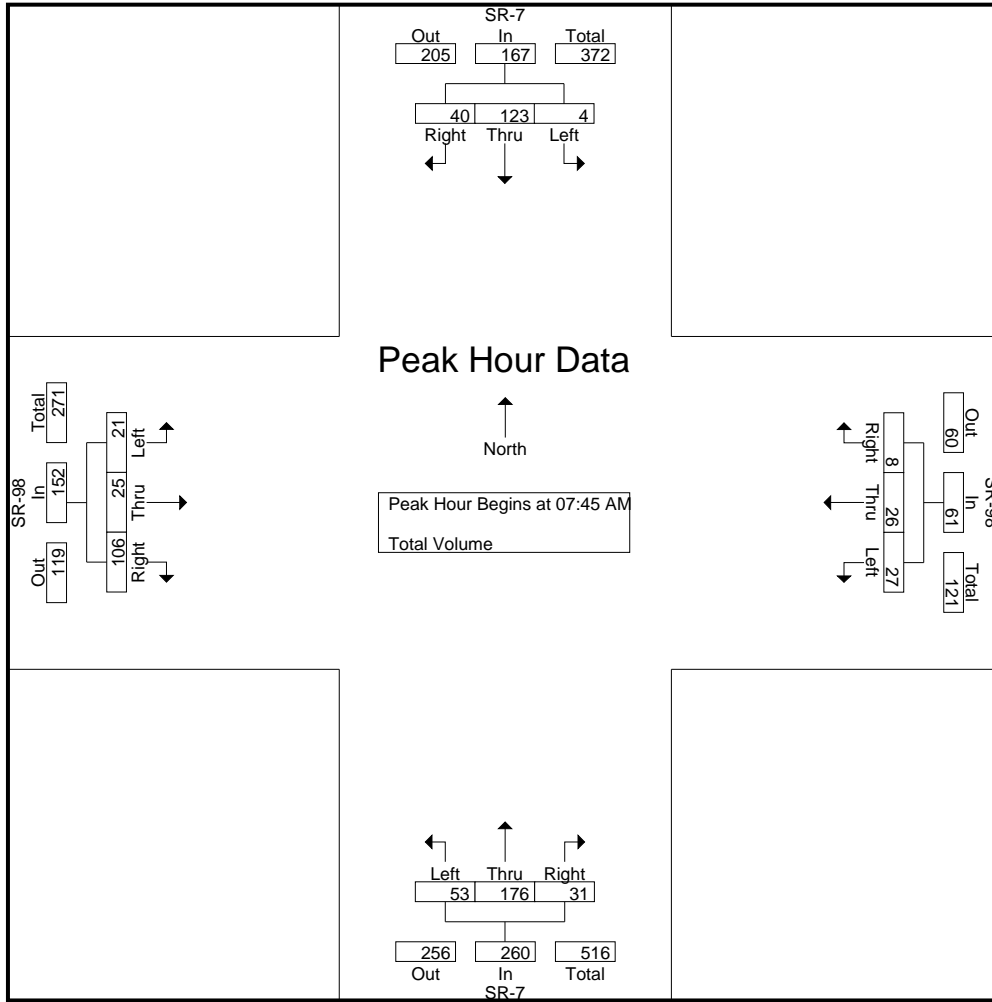
Start Time	SR-7 Southbound				SR-98 Westbound				SR-7 Northbound				SR-98 Eastbound				Int. Total
	Left	Thru	Right	App. Total	Left	Thru	Right	App. Total	Left	Thru	Right	App. Total	Left	Thru	Right	App. Total	
07:00 AM	0	15	9	24	3	12	1	16	10	56	2	68	9	7	12	28	136
07:15 AM	2	27	4	33	4	13	0	17	12	48	7	67	6	4	11	21	138
07:30 AM	5	32	5	42	6	5	1	12	21	43	4	68	7	4	12	23	145
07:45 AM	0	38	15	53	6	7	1	14	13	53	7	73	5	7	34	46	186
Total	7	112	33	152	19	37	3	59	56	200	20	276	27	22	69	118	605
08:00 AM	1	33	8	42	5	6	3	14	9	49	8	66	4	7	34	45	167
08:15 AM	2	20	9	31	7	5	1	13	17	37	8	62	6	5	20	31	137
08:30 AM	1	32	8	41	9	8	3	20	14	37	8	59	6	6	18	30	150
08:45 AM	0	26	8	34	7	5	1	13	8	36	15	59	5	7	20	32	138
Total	4	111	33	148	28	24	8	60	48	159	39	246	21	25	92	138	592
Grand Total	11	223	66	300	47	61	11	119	104	359	59	522	48	47	161	256	1197
Apprch %	3.7	74.3	22		39.5	51.3	9.2		19.9	68.8	11.3		18.8	18.4	62.9		
Total %	0.9	18.6	5.5	25.1	3.9	5.1	0.9	9.9	8.7	30	4.9	43.6	4	3.9	13.5	21.4	

Start Time	SR-7 Southbound				SR-98 Westbound				SR-7 Northbound				SR-98 Eastbound				Int. Total
	Left	Thru	Right	App. Total	Left	Thru	Right	App. Total	Left	Thru	Right	App. Total	Left	Thru	Right	App. Total	
07:45 AM	0	38	15	53	6	7	1	14	13	53	7	73	5	7	34	46	186
08:00 AM	1	33	8	42	5	6	3	14	9	49	8	66	4	7	34	45	167
08:15 AM	2	20	9	31	7	5	1	13	17	37	8	62	6	5	20	31	137
08:30 AM	1	32	8	41	9	8	3	20	14	37	8	59	6	6	18	30	150
Total Volume	4	123	40	167	27	26	8	61	53	176	31	260	21	25	106	152	640
% App. Total	2.4	73.7	24		44.3	42.6	13.1		20.4	67.7	11.9		13.8	16.4	69.7		
PHF	.500	.809	.667	.788	.750	.813	.667	.763	.779	.830	.969	.890	.875	.893	.779	.826	.860

Peak Hour Analysis From 07:00 AM to 08:45 AM - Peak 1 of 1
 Peak Hour for Entire Intersection Begins at 07:45 AM

County of Imperial
 N/S: SR-7
 E/W: SR-98
 Weather: Clear

File Name : 02_CIM_SR-7_SR98 AM
 Site Code : 04120461
 Start Date : 12/8/2020
 Page No : 2



Peak Hour Analysis From 07:00 AM to 08:45 AM - Peak 1 of 1
 Peak Hour for Each Approach Begins at:

	07:15 AM				07:45 AM				07:00 AM				07:45 AM			
+0 mins.	2	27	4	33	6	7	1	14	10	56	2	68	5	7	34	46
+15 mins.	5	32	5	42	5	6	3	14	12	48	7	67	4	7	34	45
+30 mins.	0	38	15	53	7	5	1	13	21	43	4	68	6	5	20	31
+45 mins.	1	33	8	42	9	8	3	20	13	53	7	73	6	6	18	30
Total Volume	8	130	32	170	27	26	8	61	56	200	20	276	21	25	106	152
% App. Total	4.7	76.5	18.8		44.3	42.6	13.1		20.3	72.5	7.2		13.8	16.4	69.7	
PHF	.400	.855	.533	.802	.750	.813	.667	.763	.667	.893	.714	.945	.875	.893	.779	.826

County of Imperial
 N/S: SR-7
 E/W: SR-98
 Weather: Clear

File Name : 02_CIM_SR-7_SR98 PM
 Site Code : 04120461
 Start Date : 12/8/2020
 Page No : 1

Groups Printed- Total Volume

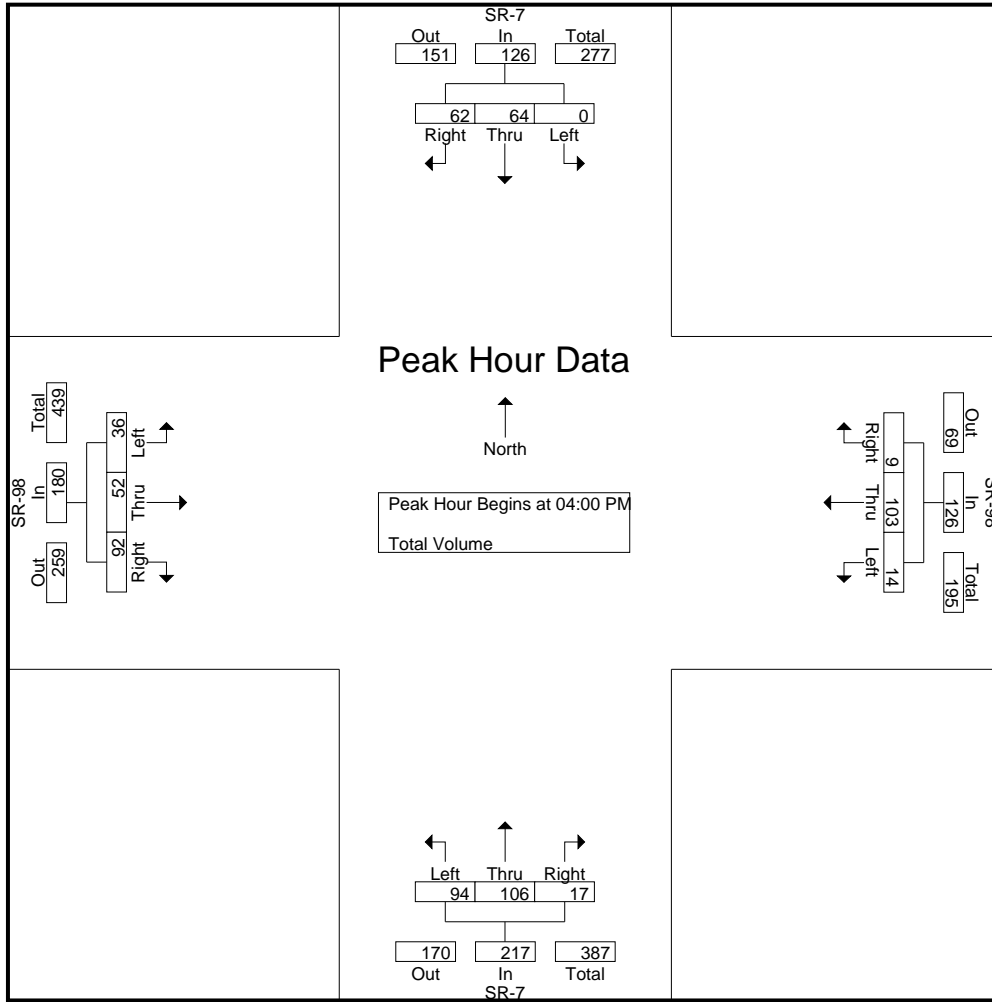
Start Time	SR-7 Southbound				SR-98 Westbound				SR-7 Northbound				SR-98 Eastbound				Int. Total
	Left	Thru	Right	App. Total	Left	Thru	Right	App. Total	Left	Thru	Right	App. Total	Left	Thru	Right	App. Total	
04:00 PM	0	19	21	40	4	43	2	49	23	34	8	65	13	16	23	52	206
04:15 PM	0	19	8	27	3	23	2	28	36	34	3	73	11	10	25	46	174
04:30 PM	0	11	21	32	4	13	3	20	25	18	4	47	5	11	30	46	145
04:45 PM	0	15	12	27	3	24	2	29	10	20	2	32	7	15	14	36	124
Total	0	64	62	126	14	103	9	126	94	106	17	217	36	52	92	180	649
05:00 PM	1	13	7	21	4	25	0	29	71	26	2	99	7	9	22	38	187
05:15 PM	1	10	18	29	7	16	0	23	30	17	2	49	7	17	23	47	148
05:30 PM	0	16	8	24	2	22	0	24	24	19	4	47	3	13	15	31	126
05:45 PM	0	17	9	26	7	23	1	31	13	7	1	21	11	13	13	37	115
Total	2	56	42	100	20	86	1	107	138	69	9	216	28	52	73	153	576
Grand Total	2	120	104	226	34	189	10	233	232	175	26	433	64	104	165	333	1225
Apprch %	0.9	53.1	46		14.6	81.1	4.3		53.6	40.4	6		19.2	31.2	49.5		
Total %	0.2	9.8	8.5	18.4	2.8	15.4	0.8	19	18.9	14.3	2.1	35.3	5.2	8.5	13.5	27.2	

Start Time	SR-7 Southbound				SR-98 Westbound				SR-7 Northbound				SR-98 Eastbound				Int. Total
	Left	Thru	Right	App. Total	Left	Thru	Right	App. Total	Left	Thru	Right	App. Total	Left	Thru	Right	App. Total	
04:00 PM	0	19	21	40	4	43	2	49	23	34	8	65	13	16	23	52	206
04:15 PM	0	19	8	27	3	23	2	28	36	34	3	73	11	10	25	46	174
04:30 PM	0	11	21	32	4	13	3	20	25	18	4	47	5	11	30	46	145
04:45 PM	0	15	12	27	3	24	2	29	10	20	2	32	7	15	14	36	124
Total Volume	0	64	62	126	14	103	9	126	94	106	17	217	36	52	92	180	649
% App. Total	0	50.8	49.2		11.1	81.7	7.1		43.3	48.8	7.8		20	28.9	51.1		
PHF	.000	.842	.738	.788	.875	.599	.750	.643	.653	.779	.531	.743	.692	.813	.767	.865	.788

Peak Hour Analysis From 04:00 PM to 05:45 PM - Peak 1 of 1
 Peak Hour for Entire Intersection Begins at 04:00 PM

County of Imperial
 N/S: SR-7
 E/W: SR-98
 Weather: Clear

File Name : 02_CIM_SR-7_SR98 PM
 Site Code : 04120461
 Start Date : 12/8/2020
 Page No : 2



Peak Hour Analysis From 04:00 PM to 05:45 PM - Peak 1 of 1
 Peak Hour for Each Approach Begins at:

	04:00 PM				04:00 PM				04:15 PM				04:00 PM			
+0 mins.	0	19	21	40	4	43	2	49	36	34	3	73	13	16	23	52
+15 mins.	0	19	8	27	3	23	2	28	25	18	4	47	11	10	25	46
+30 mins.	0	11	21	32	4	13	3	20	10	20	2	32	5	11	30	46
+45 mins.	0	15	12	27	3	24	2	29	71	26	2	99	7	15	14	36
Total Volume	0	64	62	126	14	103	9	126	142	98	11	251	36	52	92	180
% App. Total	0	50.8	49.2		11.1	81.7	7.1		56.6	39	4.4		20	28.9	51.1	
PHF	.000	.842	.738	.788	.875	.599	.750	.643	.500	.721	.688	.634	.692	.813	.767	.865

County of Imperial
 N/S: SR-7
 E/W: Herber Road
 Weather: Clear

File Name : 03_CIM_SR-7_Herber AM
 Site Code : 04120461
 Start Date : 12/8/2020
 Page No : 1

Groups Printed- Total Volume

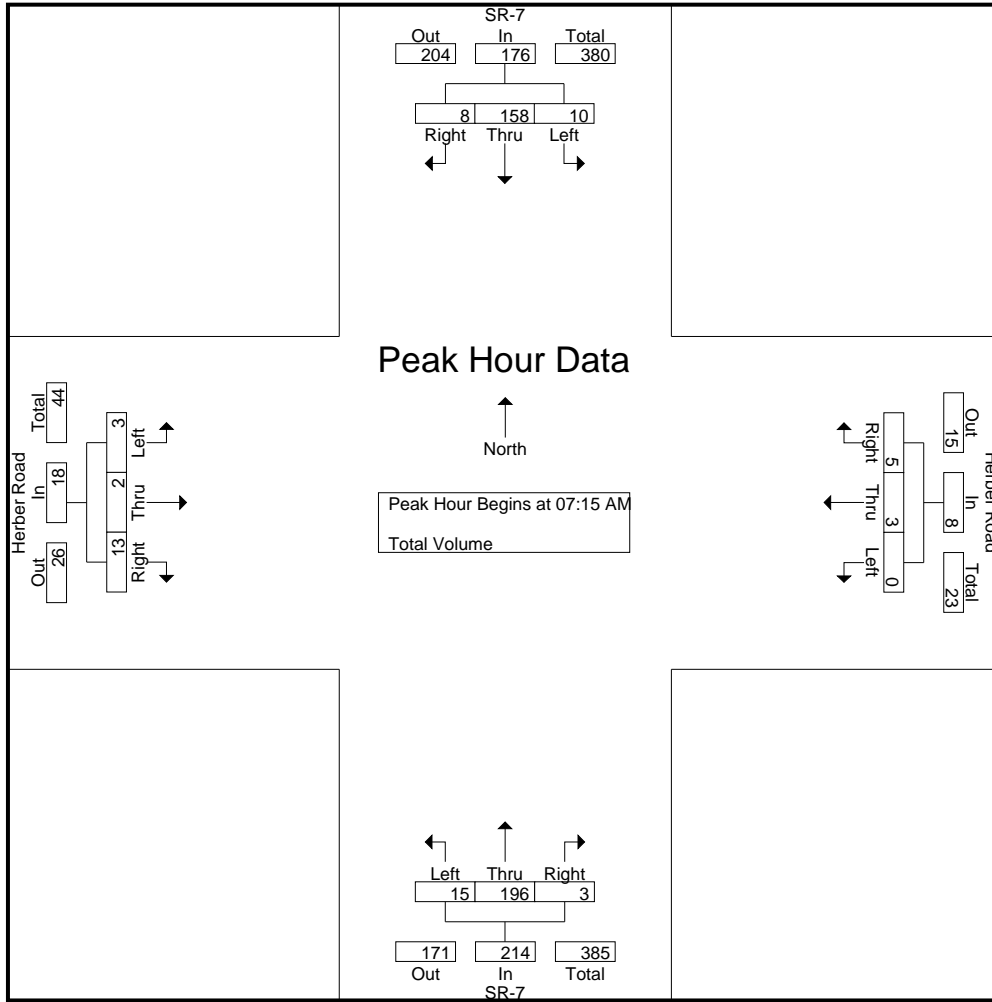
Start Time	SR-7 Southbound				Herber Road Westbound				SR-7 Northbound				Herber Road Eastbound				Int. Total
	Left	Thru	Right	App. Total	Left	Thru	Right	App. Total	Left	Thru	Right	App. Total	Left	Thru	Right	App. Total	
07:00 AM	0	31	2	33	0	1	2	3	0	57	0	57	0	0	0	0	93
07:15 AM	0	32	2	34	0	1	2	3	2	49	1	52	1	0	4	5	94
07:30 AM	4	43	0	47	0	2	1	3	5	44	1	50	1	1	4	6	106
07:45 AM	2	48	5	55	0	0	0	0	4	52	1	57	0	0	3	3	115
Total	6	154	9	169	0	4	5	9	11	202	3	216	2	1	11	14	408
08:00 AM	4	35	1	40	0	0	2	2	4	51	0	55	1	1	2	4	101
08:15 AM	4	32	0	36	0	3	1	4	4	41	0	45	5	3	1	9	94
08:30 AM	2	35	5	42	0	1	5	6	1	43	0	44	1	2	3	6	98
08:45 AM	2	38	1	41	0	1	2	3	4	39	0	43	1	0	0	1	88
Total	12	140	7	159	0	5	10	15	13	174	0	187	8	6	6	20	381
Grand Total	18	294	16	328	0	9	15	24	24	376	3	403	10	7	17	34	789
Apprch %	5.5	89.6	4.9		0	37.5	62.5		6	93.3	0.7		29.4	20.6	50		
Total %	2.3	37.3	2	41.6	0	1.1	1.9	3	3	47.7	0.4	51.1	1.3	0.9	2.2	4.3	

Start Time	SR-7 Southbound				Herber Road Westbound				SR-7 Northbound				Herber Road Eastbound				Int. Total
	Left	Thru	Right	App. Total	Left	Thru	Right	App. Total	Left	Thru	Right	App. Total	Left	Thru	Right	App. Total	
07:15 AM	0	32	2	34	0	1	2	3	2	49	1	52	1	0	4	5	94
07:30 AM	4	43	0	47	0	2	1	3	5	44	1	50	1	1	4	6	106
07:45 AM	2	48	5	55	0	0	0	0	4	52	1	57	0	0	3	3	115
08:00 AM	4	35	1	40	0	0	2	2	4	51	0	55	1	1	2	4	101
Total Volume	10	158	8	176	0	3	5	8	15	196	3	214	3	2	13	18	416
% App. Total	5.7	89.8	4.5		0	37.5	62.5		7	91.6	1.4		16.7	11.1	72.2		
PHF	.625	.823	.400	.800	.000	.375	.625	.667	.750	.942	.750	.939	.750	.500	.813	.750	.904

Peak Hour Analysis From 07:00 AM to 08:45 AM - Peak 1 of 1
 Peak Hour for Entire Intersection Begins at 07:15 AM

County of Imperial
 N/S: SR-7
 E/W: Herber Road
 Weather: Clear

File Name : 03_CIM_SR-7_Herber AM
 Site Code : 04120461
 Start Date : 12/8/2020
 Page No : 2



Peak Hour Analysis From 07:00 AM to 08:45 AM - Peak 1 of 1
 Peak Hour for Each Approach Begins at:

	07:30 AM				08:00 AM				07:00 AM				07:30 AM			
+0 mins.	4	43	0	47	0	0	2	2	0	57	0	57	1	1	4	6
+15 mins.	2	48	5	55	0	3	1	4	2	49	1	52	0	0	3	3
+30 mins.	4	35	1	40	0	1	5	6	5	44	1	50	1	1	2	4
+45 mins.	4	32	0	36	0	1	2	3	4	52	1	57	5	3	1	9
Total Volume	14	158	6	178	0	5	10	15	11	202	3	216	7	5	10	22
% App. Total	7.9	88.8	3.4		0	33.3	66.7		5.1	93.5	1.4		31.8	22.7	45.5	
PHF	.875	.823	.300	.809	.000	.417	.500	.625	.550	.886	.750	.947	.350	.417	.625	.611

County of Imperial
 N/S: SR-7
 E/W: Herber Road
 Weather: Clear

File Name : 03_CIM_SR-7_Herber PM
 Site Code : 04120461
 Start Date : 12/8/2020
 Page No : 1

Groups Printed- Total Volume

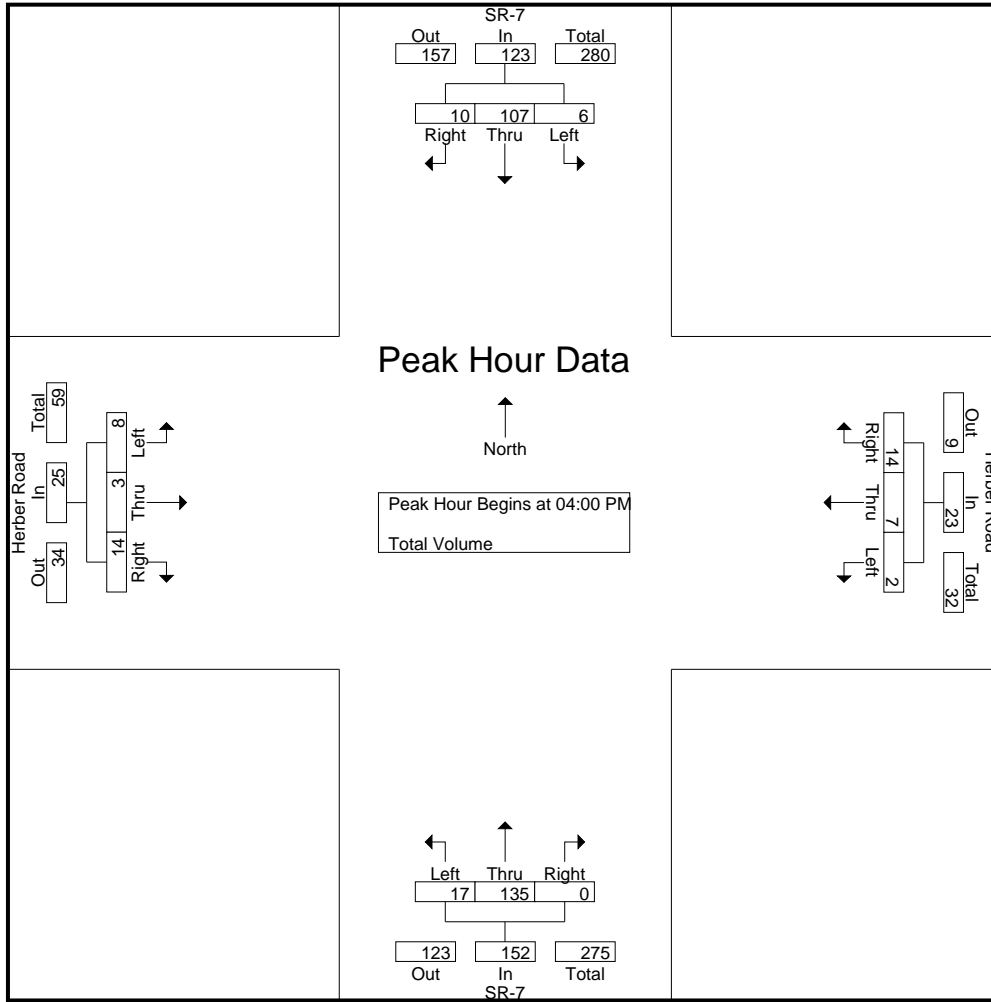
Start Time	SR-7 Southbound				Herber Road Westbound				SR-7 Northbound				Herber Road Eastbound				Int. Total
	Left	Thru	Right	App. Total	Left	Thru	Right	App. Total	Left	Thru	Right	App. Total	Left	Thru	Right	App. Total	
04:00 PM	3	31	3	37	1	3	9	13	5	39	0	44	4	0	2	6	100
04:15 PM	3	25	2	30	1	0	2	3	3	48	0	51	2	1	4	7	91
04:30 PM	0	30	3	33	0	3	0	3	5	22	0	27	2	2	4	8	71
04:45 PM	0	21	2	23	0	1	3	4	4	26	0	30	0	0	4	4	61
Total	6	107	10	123	2	7	14	23	17	135	0	152	8	3	14	25	323
05:00 PM	0	18	3	21	0	0	1	1	5	24	0	29	3	2	4	9	60
05:15 PM	1	29	3	33	0	1	2	3	4	22	0	26	0	0	1	1	63
05:30 PM	1	24	0	25	0	0	0	0	3	21	0	24	4	0	3	7	56
05:45 PM	1	19	1	21	0	1	1	2	0	18	0	18	1	0	4	5	46
Total	3	90	7	100	0	2	4	6	12	85	0	97	8	2	12	22	225
Grand Total	9	197	17	223	2	9	18	29	29	220	0	249	16	5	26	47	548
Apprch %	4	88.3	7.6		6.9	31	62.1		11.6	88.4	0		34	10.6	55.3		
Total %	1.6	35.9	3.1	40.7	0.4	1.6	3.3	5.3	5.3	40.1	0	45.4	2.9	0.9	4.7	8.6	

Start Time	SR-7 Southbound				Herber Road Westbound				SR-7 Northbound				Herber Road Eastbound				Int. Total
	Left	Thru	Right	App. Total	Left	Thru	Right	App. Total	Left	Thru	Right	App. Total	Left	Thru	Right	App. Total	
04:00 PM	3	31	3	37	1	3	9	13	5	39	0	44	4	0	2	6	100
04:15 PM	3	25	2	30	1	0	2	3	3	48	0	51	2	1	4	7	91
04:30 PM	0	30	3	33	0	3	0	3	5	22	0	27	2	2	4	8	71
04:45 PM	0	21	2	23	0	1	3	4	4	26	0	30	0	0	4	4	61
Total Volume	6	107	10	123	2	7	14	23	17	135	0	152	8	3	14	25	323
% App. Total	4.9	87	8.1		8.7	30.4	60.9		11.2	88.8	0		32	12	56		
PHF	.500	.863	.833	.831	.500	.583	.389	.442	.850	.703	.000	.745	.500	.375	.875	.781	.808

Peak Hour Analysis From 04:00 PM to 05:45 PM - Peak 1 of 1
 Peak Hour for Entire Intersection Begins at 04:00 PM

County of Imperial
 N/S: SR-7
 E/W: Herber Road
 Weather: Clear

File Name : 03_CIM_SR-7_Herber PM
 Site Code : 04120461
 Start Date : 12/8/2020
 Page No : 2



Peak Hour Analysis From 04:00 PM to 05:45 PM - Peak 1 of 1
 Peak Hour for Each Approach Begins at:

	04:00 PM				04:00 PM				04:00 PM				04:15 PM			
+0 mins.	3	31	3	37	1	3	9	13	5	39	0	44	2	1	4	7
+15 mins.	3	25	2	30	1	0	2	3	3	48	0	51	2	2	4	8
+30 mins.	0	30	3	33	0	3	0	3	5	22	0	27	0	0	4	4
+45 mins.	0	21	2	23	0	1	3	4	4	26	0	30	3	2	4	9
Total Volume	6	107	10	123	2	7	14	23	17	135	0	152	7	5	16	28
% App. Total	4.9	87	8.1		8.7	30.4	60.9		11.2	88.8	0		25	17.9	57.1	
PHF	.500	.863	.833	.831	.500	.583	.389	.442	.850	.703	.000	.745	.583	.625	1.000	.778

County of Imperial
 N/S: SR-7
 E/W: I-8 Eastbound Ramps
 Weather: Clear

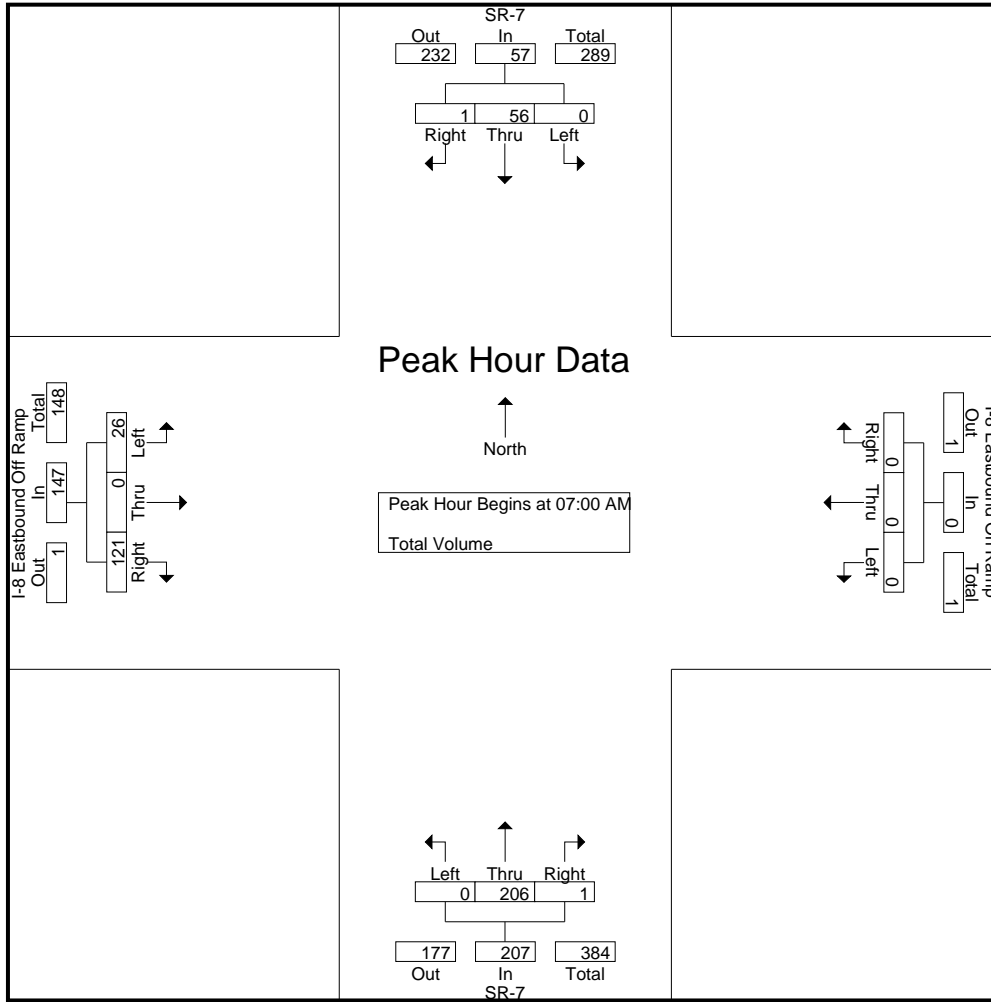
File Name : 04_CIM_SR-7_I-8E AM
 Site Code : 04120461
 Start Date : 12/8/2020
 Page No : 1

Groups Printed- Total Volume

Start Time	SR-7 Southbound				I-8 Eastbound On Ramp Westbound				SR-7 Northbound				I-8 Eastbound Off Ramp Eastbound				Int. Total
	Left	Thru	Right	App. Total	Left	Thru	Right	App. Total	Left	Thru	Right	App. Total	Left	Thru	Right	App. Total	
07:00 AM	0	13	1	14	0	0	0	0	0	61	1	62	6	0	34	40	116
07:15 AM	0	7	0	7	0	0	0	0	0	55	0	55	7	0	17	24	86
07:30 AM	0	20	0	20	0	0	0	0	0	45	0	45	6	0	36	42	107
07:45 AM	0	16	0	16	0	0	0	0	0	45	0	45	7	0	34	41	102
Total	0	56	1	57	0	0	0	0	0	206	1	207	26	0	121	147	411
08:00 AM	0	10	0	10	0	0	0	0	0	52	2	54	6	0	17	23	87
08:15 AM	0	13	0	13	0	0	0	0	0	36	3	39	6	0	24	30	82
08:30 AM	0	21	1	22	0	0	0	0	0	40	2	42	4	0	24	28	92
08:45 AM	0	15	1	16	0	0	0	0	0	47	1	48	8	0	28	36	100
Total	0	59	2	61	0	0	0	0	0	175	8	183	24	0	93	117	361
Grand Total	0	115	3	118	0	0	0	0	0	381	9	390	50	0	214	264	772
Apprch %	0	97.5	2.5		0	0	0		0	97.7	2.3		18.9	0	81.1		
Total %	0	14.9	0.4	15.3	0	0	0		0	49.4	1.2	50.5	6.5	0	27.7	34.2	

Start Time	SR-7 Southbound				I-8 Eastbound On Ramp Westbound				SR-7 Northbound				I-8 Eastbound Off Ramp Eastbound				Int. Total
	Left	Thru	Right	App. Total	Left	Thru	Right	App. Total	Left	Thru	Right	App. Total	Left	Thru	Right	App. Total	
07:00 AM	0	13	1	14	0	0	0	0	0	61	1	62	6	0	34	40	116
07:15 AM	0	7	0	7	0	0	0	0	0	55	0	55	7	0	17	24	86
07:30 AM	0	20	0	20	0	0	0	0	0	45	0	45	6	0	36	42	107
07:45 AM	0	16	0	16	0	0	0	0	0	45	0	45	7	0	34	41	102
Total Volume	0	56	1	57	0	0	0	0	0	206	1	207	26	0	121	147	411
% App. Total	0	98.2	1.8		0	0	0		0	99.5	0.5		17.7	0	82.3		
PHF	.000	.700	.250	.713	.000	.000	.000	.000	.000	.844	.250	.835	.929	.000	.840	.875	.886

Peak Hour Analysis From 07:00 AM to 08:45 AM - Peak 1 of 1
 Peak Hour for Entire Intersection Begins at 07:00 AM



Peak Hour Analysis From 07:00 AM to 08:45 AM - Peak 1 of 1
 Peak Hour for Each Approach Begins at:

	07:45 AM				07:00 AM				07:00 AM				07:00 AM			
+0 mins.	0	16	0	16	0	0	0	0	0	61	1	62	6	0	34	40
+15 mins.	0	10	0	10	0	0	0	0	0	55	0	55	7	0	17	24
+30 mins.	0	13	0	13	0	0	0	0	0	45	0	45	6	0	36	42
+45 mins.	0	21	1	22	0	0	0	0	0	45	0	45	7	0	34	41
Total Volume	0	60	1	61	0	0	0	0	0	206	1	207	26	0	121	147
% App. Total	0	98.4	1.6		0	0	0		0	99.5	0.5		17.7	0	82.3	
PHF	.000	.714	.250	.693	.000	.000	.000	.000	.000	.844	.250	.835	.929	.000	.840	.875

County of Imperial
 N/S: SR-7
 E/W: I-8 Eastbound Ramps
 Weather: Clear

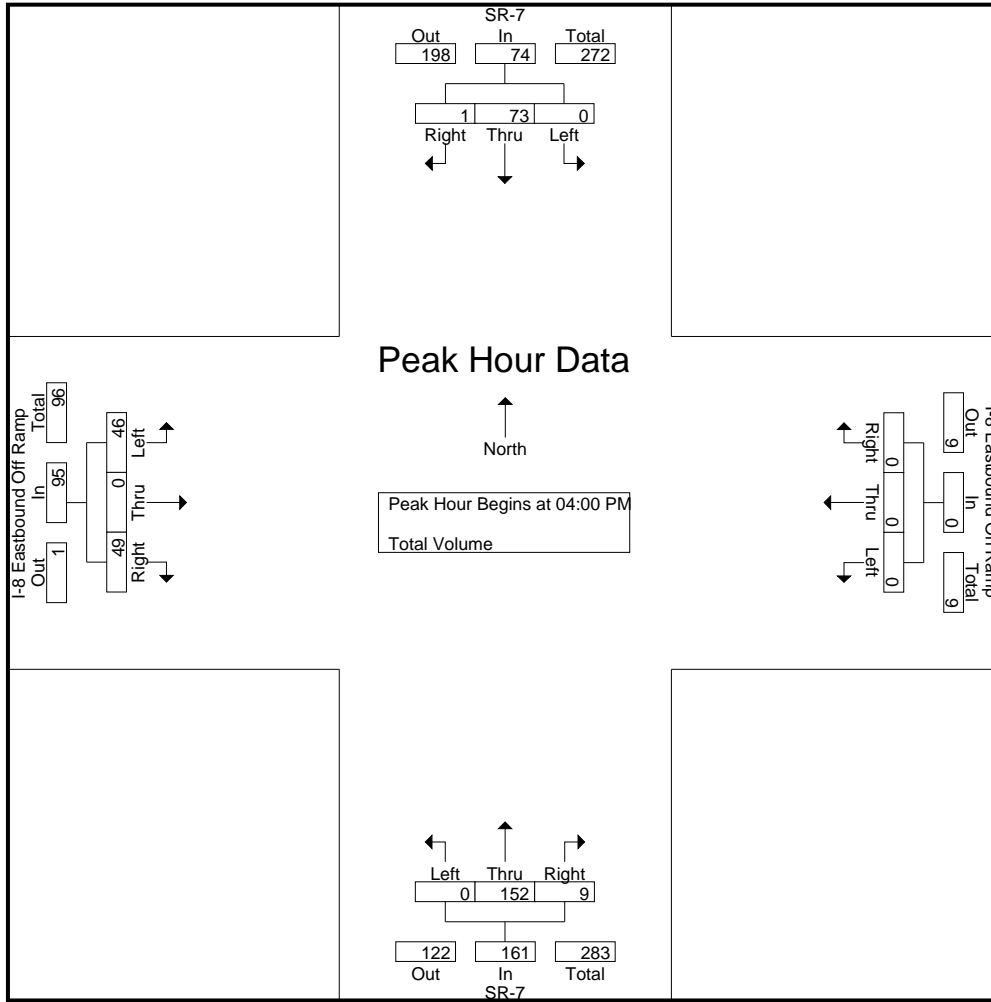
File Name : 04_CIM_SR-7_I-8E PM
 Site Code : 04120461
 Start Date : 12/8/2020
 Page No : 1

Groups Printed- Total Volume

Start Time	SR-7 Southbound				I-8 Eastbound On Ramp Westbound				SR-7 Northbound				I-8 Eastbound Off Ramp Eastbound				Int. Total
	Left	Thru	Right	App. Total	Left	Thru	Right	App. Total	Left	Thru	Right	App. Total	Left	Thru	Right	App. Total	
04:00 PM	0	23	0	23	0	0	0	0	0	49	2	51	6	0	14	20	94
04:15 PM	0	17	0	17	0	0	0	0	0	49	4	53	14	0	12	26	96
04:30 PM	0	22	1	23	0	0	0	0	0	25	1	26	18	0	12	30	79
04:45 PM	0	11	0	11	0	0	0	0	0	29	2	31	8	0	11	19	61
Total	0	73	1	74	0	0	0	0	0	152	9	161	46	0	49	95	330
05:00 PM	0	18	2	20	0	0	0	0	0	27	2	29	18	0	9	27	76
05:15 PM	0	14	3	17	0	0	0	0	0	20	1	21	18	0	15	33	71
05:30 PM	0	15	1	16	0	0	0	0	0	24	0	24	23	0	10	33	73
05:45 PM	0	13	0	13	0	0	0	0	0	21	2	23	14	0	9	23	59
Total	0	60	6	66	0	0	0	0	0	92	5	97	73	0	43	116	279
Grand Total	0	133	7	140	0	0	0	0	0	244	14	258	119	0	92	211	609
Apprch %	0	95	5		0	0	0		0	94.6	5.4		56.4	0	43.6		
Total %	0	21.8	1.1	23	0	0	0	0	0	40.1	2.3	42.4	19.5	0	15.1	34.6	

Start Time	SR-7 Southbound				I-8 Eastbound On Ramp Westbound				SR-7 Northbound				I-8 Eastbound Off Ramp Eastbound				Int. Total
	Left	Thru	Right	App. Total	Left	Thru	Right	App. Total	Left	Thru	Right	App. Total	Left	Thru	Right	App. Total	
04:00 PM	0	23	0	23	0	0	0	0	0	49	2	51	6	0	14	20	94
04:15 PM	0	17	0	17	0	0	0	0	0	49	4	53	14	0	12	26	96
04:30 PM	0	22	1	23	0	0	0	0	0	25	1	26	18	0	12	30	79
04:45 PM	0	11	0	11	0	0	0	0	0	29	2	31	8	0	11	19	61
Total Volume	0	73	1	74	0	0	0	0	0	152	9	161	46	0	49	95	330
% App. Total	0	98.6	1.4		0	0	0		0	94.4	5.6		48.4	0	51.6		
PHF	.000	.793	.250	.804	.000	.000	.000	.000	.000	.776	.563	.759	.639	.000	.875	.792	.859

Peak Hour Analysis From 04:00 PM to 05:45 PM - Peak 1 of 1
 Peak Hour for Entire Intersection Begins at 04:00 PM



Peak Hour Analysis From 04:00 PM to 05:45 PM - Peak 1 of 1
 Peak Hour for Each Approach Begins at:

	04:00 PM				04:00 PM				04:00 PM				05:00 PM			
+0 mins.	0	23	0	23	0	0	0	0	0	49	2	51	18	0	9	27
+15 mins.	0	17	0	17	0	0	0	0	0	49	4	53	18	0	15	33
+30 mins.	0	22	1	23	0	0	0	0	0	25	1	26	23	0	10	33
+45 mins.	0	11	0	11	0	0	0	0	0	29	2	31	14	0	9	23
Total Volume	0	73	1	74	0	0	0	0	0	152	9	161	73	0	43	116
% App. Total	0	98.6	1.4		0	0	0		0	94.4	5.6		62.9	0	37.1	
PHF	.000	.793	.250	.804	.000	.000	.000	.000	.000	.776	.563	.759	.793	.000	.717	.879

County of Imperial
 N/S: Orchard Road/SR-7
 E/W: I-8 Westbound Ramps
 Weather: Clear

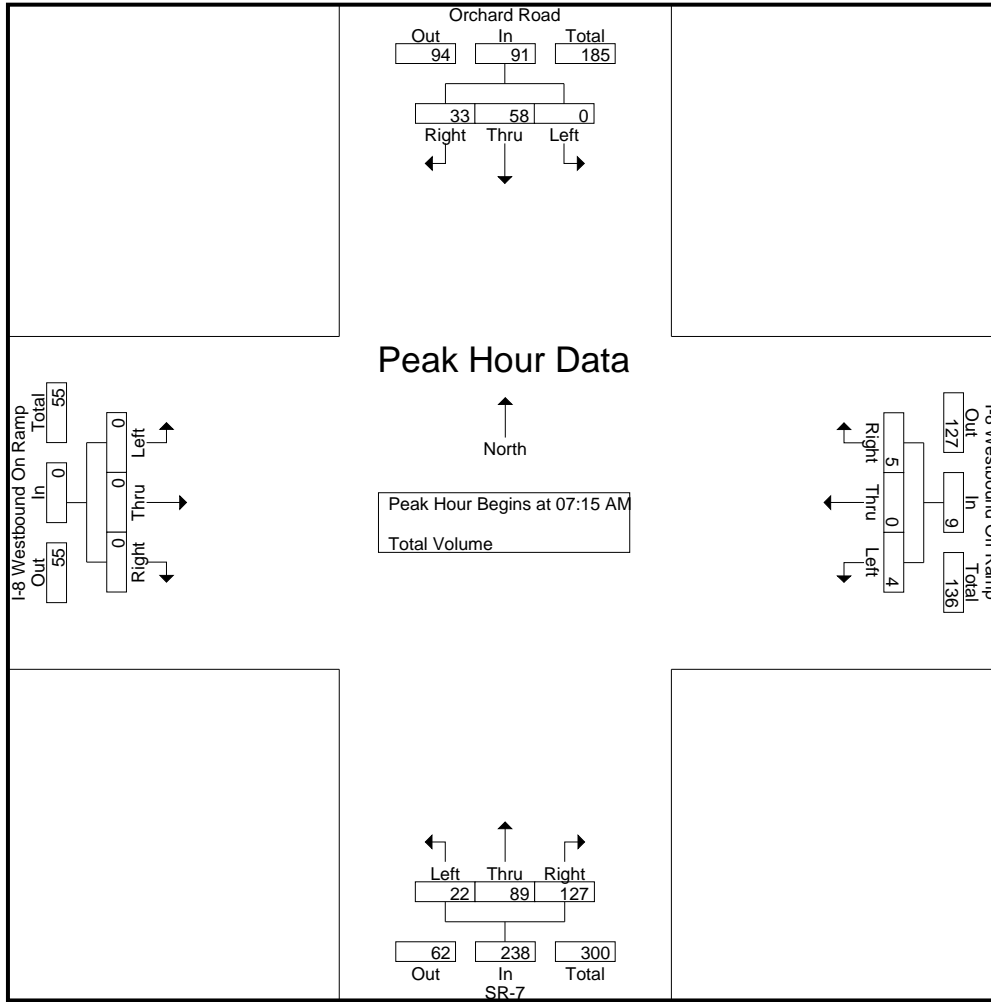
File Name : 05_CIM_Orchard_I-8E AM
 Site Code : 04120461
 Start Date : 12/8/2020
 Page No : 1

Groups Printed- Total Volume

Start Time	Orchard Road Southbound				I-8 Westbound Off Ramp Westbound				SR-7 Northbound				I-8 Westbound On Ramp Eastbound				Int. Total
	Left	Thru	Right	App. Total	Left	Thru	Right	App. Total	Left	Thru	Right	App. Total	Left	Thru	Right	App. Total	
07:00 AM	0	10	7	17	0	0	1	1	4	26	28	58	0	0	0	0	76
07:15 AM	0	9	6	15	1	0	0	1	9	27	32	68	0	0	0	0	84
07:30 AM	0	19	10	29	1	0	1	2	3	20	25	48	0	0	0	0	79
07:45 AM	0	19	13	32	1	0	2	3	7	24	30	61	0	0	0	0	96
Total	0	57	36	93	3	0	4	7	23	97	115	235	0	0	0	0	335
08:00 AM	0	11	4	15	1	0	2	3	3	18	40	61	0	0	0	0	79
08:15 AM	0	16	9	25	0	0	0	0	0	21	22	43	0	0	0	0	68
08:30 AM	0	18	6	24	3	0	0	3	5	17	27	49	0	0	0	0	76
08:45 AM	0	15	11	26	0	0	2	2	6	21	28	55	0	0	0	0	83
Total	0	60	30	90	4	0	4	8	14	77	117	208	0	0	0	0	306
Grand Total	0	117	66	183	7	0	8	15	37	174	232	443	0	0	0	0	641
Apprch %	0	63.9	36.1		46.7	0	53.3		8.4	39.3	52.4		0	0	0		
Total %	0	18.3	10.3	28.5	1.1	0	1.2	2.3	5.8	27.1	36.2	69.1	0	0	0	0	

Start Time	Orchard Road Southbound				I-8 Westbound Off Ramp Westbound				SR-7 Northbound				I-8 Westbound On Ramp Eastbound				Int. Total
	Left	Thru	Right	App. Total	Left	Thru	Right	App. Total	Left	Thru	Right	App. Total	Left	Thru	Right	App. Total	
07:15 AM	0	9	6	15	1	0	0	1	9	27	32	68	0	0	0	0	84
07:30 AM	0	19	10	29	1	0	1	2	3	20	25	48	0	0	0	0	79
07:45 AM	0	19	13	32	1	0	2	3	7	24	30	61	0	0	0	0	96
08:00 AM	0	11	4	15	1	0	2	3	3	18	40	61	0	0	0	0	79
Total Volume	0	58	33	91	4	0	5	9	22	89	127	238	0	0	0	0	338
% App. Total	0	63.7	36.3		44.4	0	55.6		9.2	37.4	53.4		0	0	0		
PHF	.000	.763	.635	.711	1.00	.000	.625	.750	.611	.824	.794	.875	.000	.000	.000	.000	.880

Peak Hour Analysis From 07:00 AM to 08:45 AM - Peak 1 of 1
 Peak Hour for Entire Intersection Begins at 07:15 AM



Peak Hour Analysis From 07:00 AM to 08:45 AM - Peak 1 of 1
 Peak Hour for Each Approach Begins at:

	07:30 AM				07:15 AM				07:15 AM				07:00 AM			
+0 mins.	0	19	10	29	1	0	0	1	9	27	32	68	0	0	0	0
+15 mins.	0	19	13	32	1	0	1	2	3	20	25	48	0	0	0	0
+30 mins.	0	11	4	15	1	0	2	3	7	24	30	61	0	0	0	0
+45 mins.	0	16	9	25	1	0	2	3	3	18	40	61	0	0	0	0
Total Volume	0	65	36	101	4	0	5	9	22	89	127	238	0	0	0	0
% App. Total	0	64.4	35.6		44.4	0	55.6		9.2	37.4	53.4		0	0	0	
PHF	.000	.855	.692	.789	1.000	.000	.625	.750	.611	.824	.794	.875	.000	.000	.000	.000

County of Imperial
 N/S: Orchard Road/SR-7
 E/W: I-8 Westbound Ramps
 Weather: Clear

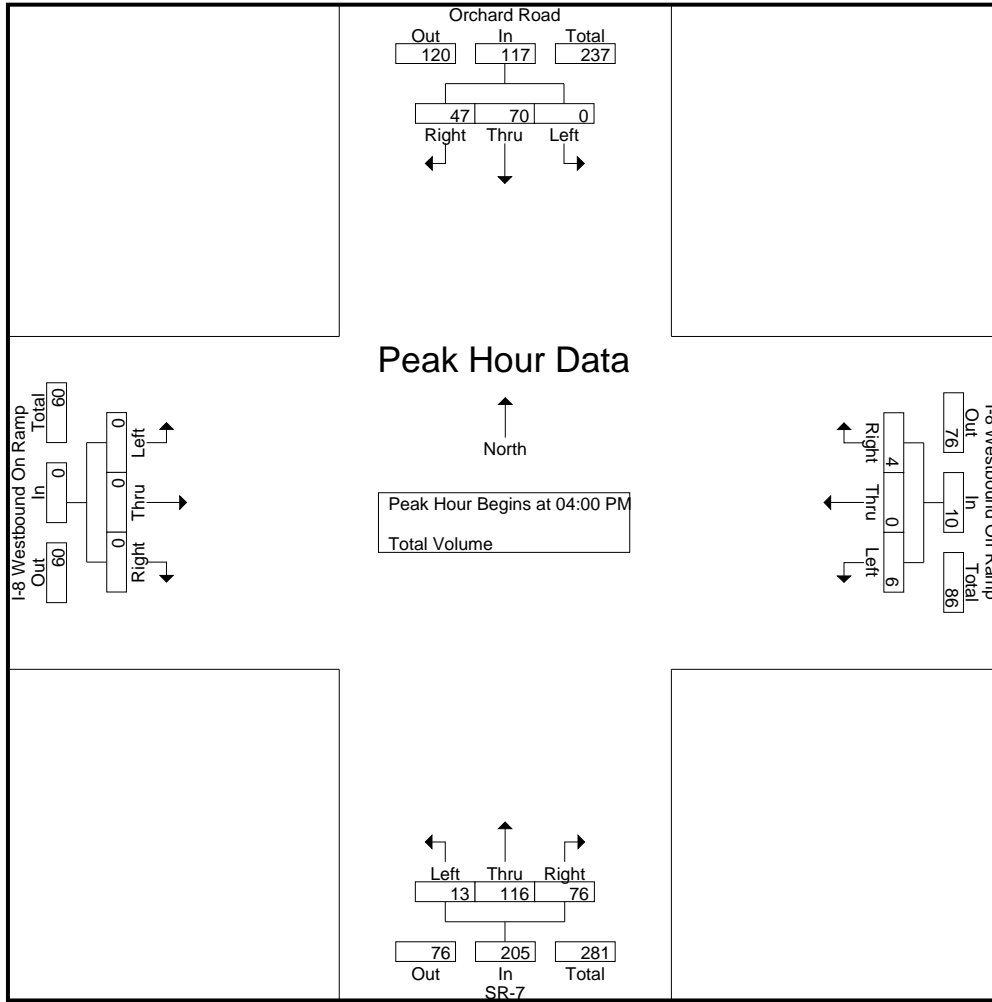
File Name : 05_CIM_Orchard_I-8E PM
 Site Code : 04120461
 Start Date : 12/8/2020
 Page No : 1

Groups Printed- Total Volume

Start Time	Orchard Road Southbound				I-8 Westbound Off Ramp Westbound				SR-7 Northbound				I-8 Westbound On Ramp Eastbound				Int. Total
	Left	Thru	Right	App. Total	Left	Thru	Right	App. Total	Left	Thru	Right	App. Total	Left	Thru	Right	App. Total	
04:00 PM	0	21	11	32	3	0	1	4	4	24	26	54	0	0	0	0	90
04:15 PM	0	16	10	26	3	0	2	5	3	41	25	69	0	0	0	0	100
04:30 PM	0	21	11	32	0	0	0	0	1	28	8	37	0	0	0	0	69
04:45 PM	0	12	15	27	0	0	1	1	5	23	17	45	0	0	0	0	73
Total	0	70	47	117	6	0	4	10	13	116	76	205	0	0	0	0	332
05:00 PM	0	13	8	21	7	0	1	8	2	23	16	41	0	0	0	0	70
05:15 PM	0	16	4	20	2	0	0	2	1	24	12	37	0	0	0	0	59
05:30 PM	0	14	10	24	1	0	2	3	1	31	17	49	0	0	0	0	76
05:45 PM	0	7	7	14	5	0	1	6	0	21	14	35	0	0	0	0	55
Total	0	50	29	79	15	0	4	19	4	99	59	162	0	0	0	0	260
Grand Total	0	120	76	196	21	0	8	29	17	215	135	367	0	0	0	0	592
Apprch %	0	61.2	38.8		72.4	0	27.6		4.6	58.6	36.8		0	0	0		
Total %	0	20.3	12.8	33.1	3.5	0	1.4	4.9	2.9	36.3	22.8	62	0	0	0	0	

Start Time	Orchard Road Southbound				I-8 Westbound Off Ramp Westbound				SR-7 Northbound				I-8 Westbound On Ramp Eastbound				Int. Total
	Left	Thru	Right	App. Total	Left	Thru	Right	App. Total	Left	Thru	Right	App. Total	Left	Thru	Right	App. Total	
04:00 PM	0	21	11	32	3	0	1	4	4	24	26	54	0	0	0	0	90
04:15 PM	0	16	10	26	3	0	2	5	3	41	25	69	0	0	0	0	100
04:30 PM	0	21	11	32	0	0	0	0	1	28	8	37	0	0	0	0	69
04:45 PM	0	12	15	27	0	0	1	1	5	23	17	45	0	0	0	0	73
Total Volume	0	70	47	117	6	0	4	10	13	116	76	205	0	0	0	0	332
% App. Total	0	59.8	40.2		60	0	40		6.3	56.6	37.1		0	0	0		
PHF	.000	.833	.783	.914	.500	.000	.500	.500	.650	.707	.731	.743	.000	.000	.000	.000	.830

Peak Hour Analysis From 04:00 PM to 05:45 PM - Peak 1 of 1
 Peak Hour for Entire Intersection Begins at 04:00 PM



Peak Hour Analysis From 04:00 PM to 05:45 PM - Peak 1 of 1
 Peak Hour for Each Approach Begins at:

	04:00 PM				05:00 PM				04:00 PM				04:00 PM			
+0 mins.	0	21	11	32	7	0	1	8	4	24	26	54	0	0	0	0
+15 mins.	0	16	10	26	2	0	0	2	3	41	25	69	0	0	0	0
+30 mins.	0	21	11	32	1	0	2	3	1	28	8	37	0	0	0	0
+45 mins.	0	12	15	27	5	0	1	6	5	23	17	45	0	0	0	0
Total Volume	0	70	47	117	15	0	4	19	13	116	76	205	0	0	0	0
% App. Total	0	59.8	40.2		78.9	0	21.1		6.3	56.6	37.1		0	0	0	
PHF	.000	.833	.783	.914	.536	.000	.500	.594	.650	.707	.731	.743	.000	.000	.000	.000

APPENDIX B : EXISTING YEAR CONDITIONS ANALYSIS WORKSHEETS

Intersection						
Int Delay, s/veh	0					
Movement	EBT	EBR	WBL	WBT	NBL	NBR
Lane Configurations						
Traffic Vol, veh/h	61	0	0	54	0	0
Future Vol, veh/h	61	0	0	54	0	0
Conflicting Peds, #/hr	0	0	0	0	0	0
Sign Control	Free	Free	Free	Free	Stop	Stop
RT Channelized	-	None	-	None	-	None
Storage Length	-	-	-	-	0	-
Veh in Median Storage, #	0	-	-	0	0	-
Grade, %	0	-	-	0	0	-
Peak Hour Factor	92	92	92	92	92	92
Heavy Vehicles, %	2	2	2	2	2	2
Mvmt Flow	66	0	0	59	0	0

Major/Minor	Major1	Major2	Minor1		
Conflicting Flow All	0	0	66	0	125 66
Stage 1	-	-	-	-	66 -
Stage 2	-	-	-	-	59 -
Critical Hdwy	-	-	4.12	-	6.42 6.22
Critical Hdwy Stg 1	-	-	-	-	5.42 -
Critical Hdwy Stg 2	-	-	-	-	5.42 -
Follow-up Hdwy	-	-	2.218	-	3.518 3.318
Pot Cap-1 Maneuver	-	-	1536	-	870 998
Stage 1	-	-	-	-	957 -
Stage 2	-	-	-	-	964 -
Platoon blocked, %	-	-	-	-	-
Mov Cap-1 Maneuver	-	-	1536	-	870 998
Mov Cap-2 Maneuver	-	-	-	-	870 -
Stage 1	-	-	-	-	957 -
Stage 2	-	-	-	-	964 -

Approach	EB	WB	NB
HCM Control Delay, s	0	0	0
HCM LOS			A

Minor Lane/Major Mvmt	NBLn1	EBT	EBR	WBL	WBT
Capacity (veh/h)	-	-	-	1536	-
HCM Lane V/C Ratio	-	-	-	-	-
HCM Control Delay (s)	0	-	-	0	-
HCM Lane LOS	A	-	-	A	-
HCM 95th %tile Q(veh)	-	-	-	0	-

Intersection						
Int Delay, s/veh	0					
Movement	EBT	EBR	WBL	WBT	NBL	NBR
Lane Configurations						
Traffic Vol, veh/h	66	0	0	82	0	0
Future Vol, veh/h	66	0	0	82	0	0
Conflicting Peds, #/hr	0	0	0	0	0	0
Sign Control	Free	Free	Free	Free	Stop	Stop
RT Channelized	-	None	-	None	-	None
Storage Length	-	-	-	-	0	-
Veh in Median Storage, #	0	-	-	0	0	-
Grade, %	0	-	-	0	0	-
Peak Hour Factor	92	92	92	92	92	92
Heavy Vehicles, %	2	2	2	2	2	2
Mvmt Flow	72	0	0	89	0	0

Major/Minor	Major1	Major2	Minor1	Minor2	Minor3
Conflicting Flow All	0	0	72	0	161
Stage 1	-	-	-	-	72
Stage 2	-	-	-	-	89
Critical Hdwy	-	-	4.12	-	6.42
Critical Hdwy Stg 1	-	-	-	-	5.42
Critical Hdwy Stg 2	-	-	-	-	5.42
Follow-up Hdwy	-	-	2.218	-	3.518
Pot Cap-1 Maneuver	-	-	1528	-	830
Stage 1	-	-	-	-	951
Stage 2	-	-	-	-	934
Platoon blocked, %	-	-	-	-	-
Mov Cap-1 Maneuver	-	-	1528	-	830
Mov Cap-2 Maneuver	-	-	-	-	830
Stage 1	-	-	-	-	951
Stage 2	-	-	-	-	934

Approach	EB	WB	NB
HCM Control Delay, s	0	0	0
HCM LOS			A

Minor Lane/Major Mvmt	NBLn1	EBT	EBR	WBL	WBT
Capacity (veh/h)	-	-	-	1528	-
HCM Lane V/C Ratio	-	-	-	-	-
HCM Control Delay (s)	0	-	-	0	-
HCM Lane LOS	A	-	-	A	-
HCM 95th %tile Q(veh)	-	-	-	0	-

Intersection						
Int Delay, s/veh	1.3					
Movement	EBL	EBT	WBT	WBR	SBL	SBR
Lane Configurations	↙	↑	↗		↙	↗
Traffic Vol, veh/h	10	61	54	7	6	7
Future Vol, veh/h	10	61	54	7	6	7
Conflicting Peds, #/hr	0	0	0	0	0	0
Sign Control	Free	Free	Free	Free	Stop	Stop
RT Channelized	-	None	-	None	-	None
Storage Length	0	-	-	-	0	0
Veh in Median Storage, #	-	0	0	-	0	-
Grade, %	-	0	0	-	0	-
Peak Hour Factor	92	92	92	92	92	92
Heavy Vehicles, %	2	2	2	2	2	2
Mvmt Flow	11	66	59	8	7	8

Major/Minor	Major1	Major2	Minor2		
Conflicting Flow All	67	0	-	0	151
Stage 1	-	-	-	-	63
Stage 2	-	-	-	-	88
Critical Hdwy	4.12	-	-	-	6.42
Critical Hdwy Stg 1	-	-	-	-	5.42
Critical Hdwy Stg 2	-	-	-	-	5.42
Follow-up Hdwy	2.218	-	-	-	3.518
Pot Cap-1 Maneuver	1535	-	-	-	841
Stage 1	-	-	-	-	960
Stage 2	-	-	-	-	935
Platoon blocked, %		-	-	-	
Mov Cap-1 Maneuver	1535	-	-	-	835
Mov Cap-2 Maneuver	-	-	-	-	835
Stage 1	-	-	-	-	953
Stage 2	-	-	-	-	935

Approach	EB	WB	SB
HCM Control Delay, s	1	0	8.9
HCM LOS			A

Minor Lane/Major Mvmt	EBL	EBT	WBT	WBR	SBLn1	SBLn2
Capacity (veh/h)	1535	-	-	-	835	1002
HCM Lane V/C Ratio	0.007	-	-	-	0.008	0.008
HCM Control Delay (s)	7.4	-	-	-	9.3	8.6
HCM Lane LOS	A	-	-	-	A	A
HCM 95th %tile Q(veh)	0	-	-	-	0	0

Intersection

Int Delay, s/veh 1.1

Movement	EBL	EBT	WBT	WBR	SBL	SBR
Lane Configurations	↙	↑	↘		↙	↘
Traffic Vol, veh/h	5	66	82	10	2	17
Future Vol, veh/h	5	66	82	10	2	17
Conflicting Peds, #/hr	0	0	0	0	0	0
Sign Control	Free	Free	Free	Free	Stop	Stop
RT Channelized	-	None	-	None	-	None
Storage Length	0	-	-	-	0	0
Veh in Median Storage, #	-	0	0	-	0	-
Grade, %	-	0	0	-	0	-
Peak Hour Factor	92	92	92	92	92	92
Heavy Vehicles, %	2	2	2	2	2	2
Mvmt Flow	5	72	89	11	2	18

























Major/Minor	Major1	Major2	Minor2
Conflicting Flow All	100	0	0
Stage 1	-	-	95
Stage 2	-	-	82
Critical Hdwy	4.12	-	6.42
Critical Hdwy Stg 1	-	-	5.42
Critical Hdwy Stg 2	-	-	5.42
Follow-up Hdwy	2.218	-	3.518
Pot Cap-1 Maneuver	1493	-	813
Stage 1	-	-	929
Stage 2	-	-	941
Platoon blocked, %	-	-	-
Mov Cap-1 Maneuver	1493	-	811
Mov Cap-2 Maneuver	-	-	811
Stage 1	-	-	926
Stage 2	-	-	941

Approach	EB	WB	SB
HCM Control Delay, s	0.5	0	8.9
HCM LOS			A

Minor Lane/Major Mvmt	EBL	EBT	WBT	WBR	SBLn1	SBLn2
Capacity (veh/h)	1493	-	-	-	811	962
HCM Lane V/C Ratio	0.004	-	-	-	0.003	0.019
HCM Control Delay (s)	7.4	-	-	-	9.5	8.8
HCM Lane LOS	A	-	-	-	A	A
HCM 95th %tile Q(veh)	0	-	-	-	0	0.1

HCM 2010 Signalized Intersection Capacity Analysis
 12: CA 7 & CA 98

01/07/2021

												
Movement	EBL	EBT	EBR	WBL	WBT	WBR	NBL	NBT	NBR	SBL	SBT	SBR
Lane Configurations												
Traffic Volume (veh/h)	21	25	106	27	26	8	53	176	31	4	123	40
Future Volume (veh/h)	21	25	106	27	26	8	53	176	31	4	123	40
Number	7	4	14	3	8	18	5	2	12	1	6	16
Initial Q, veh	0	0	0	0	0	0	0	0	0	0	0	0
Ped-Bike Adj (A_pbT)	1.00		1.00	1.00		1.00	1.00		1.00	1.00		1.00
Parking Bus Adj	1.00	1.00	1.00	1.00	1.00	1.00	1.00	1.00	1.00	1.00	1.00	1.00
Adj Sat Flow, veh/h/ln	1863	1863	1863	1863	1863	1863	1863	1863	1863	1863	1863	1863
Adj Flow Rate, veh/h	23	27	115	29	28	9	58	191	34	4	134	43
Adj No. of Lanes	1	1	2	1	1	1	2	2	1	1	2	1
Peak Hour Factor	0.92	0.92	0.92	0.92	0.92	0.92	0.92	0.92	0.92	0.92	0.92	0.92
Percent Heavy Veh, %	2	2	2	2	2	2	2	2	2	2	2	2
Opposing Right Turn Influence	Yes			Yes			Yes			Yes		
Cap, veh/h	694	745	1115	646	745	633	1198	1416	633	581	1416	633
HCM Platoon Ratio	1.00	1.00	1.00	1.00	1.00	1.00	1.00	1.00	1.00	1.00	1.00	1.00
Prop Arrive On Green	0.40	0.40	0.40	0.40	0.40	0.40	0.40	0.40	0.40	0.40	0.40	0.40
Ln Grp Delay, s/veh	8.6	8.3	8.6	8.7	8.3	8.2	9.0	8.8	8.4	9.1	8.6	8.5
Ln Grp LOS	A	A	A	A	A	A	A	A	A	A	A	A
Approach Vol, veh/h		165			66			283			181	
Approach Delay, s/veh		8.6			8.5			8.8			8.6	
Approach LOS		A			A			A			A	
Timer:		1	2	3	4	5	6	7	8			
Assigned Phs			2		4		6		8			
Case No			5.0		5.0		5.0		5.0			
Phs Duration (G+Y+Rc), s			22.5		22.5		22.5		22.5			
Change Period (Y+Rc), s			4.5		4.5		4.5		4.5			
Max Green (Gmax), s			18.0		18.0		18.0		18.0			
Max Allow Headway (MAH), s			4.9		4.2		4.9		4.6			
Max Q Clear (g_c+I1), s			3.8		3.2		3.6		3.1			
Green Ext Time (g_e), s			1.3		0.5		0.7		0.2			
Prob of Phs Call (p_c)			1.00		1.00		1.00		1.00			
Prob of Max Out (p_x)			0.00		0.00		0.00		0.00			
Left-Turn Movement Data												
Assigned Mvmt			5		7		1		3			
Mvmt Sat Flow, veh/h			2333		1365		1151		1241			
Through Movement Data												
Assigned Mvmt			2		4		6		8			
Mvmt Sat Flow, veh/h			3539		1863		3539		1863			
Right-Turn Movement Data												
Assigned Mvmt			12		14		16		18			
Mvmt Sat Flow, veh/h			1583		2787		1583		1583			
Left Lane Group Data												
Assigned Mvmt		0	5	0	7	0	1	0	3			
Lane Assignment												

HCM 2010 Signalized Intersection Capacity Analysis
 12: CA 7 & CA 98

01/07/2021

Lanes in Grp	0	2	0	1	0	1	0	1
Grp Vol (v), veh/h	0	58	0	23	0	4	0	29
Grp Sat Flow (s), veh/h/ln	0	1166	0	1365	0	1151	0	1241
Q Serve Time (g_s), s	0.0	0.7	0.0	0.5	0.0	0.1	0.0	0.7
Cycle Q Clear Time (g_c), s	0.0	1.8	0.0	0.9	0.0	1.6	0.0	1.1
Perm LT Sat Flow (s_l), veh/h/ln	0	1166	0	1365	0	1151	0	1241
Shared LT Sat Flow (s_sh), veh/h/ln	0	0	0	0	0	0	0	0
Perm LT Eff Green (g_p), s	0.0	18.0	0.0	18.0	0.0	18.0	0.0	18.0
Perm LT Serve Time (g_u), s	0.0	16.9	0.0	17.6	0.0	16.5	0.0	17.6
Perm LT Q Serve Time (g_ps), s	0.0	0.7	0.0	0.5	0.0	0.1	0.0	0.7
Time to First Blk (g_f), s	0.0	0.0	0.0	0.0	0.0	0.0	0.0	0.0
Serve Time pre Blk (g_fs), s	0.0	0.0	0.0	0.0	0.0	0.0	0.0	0.0
Prop LT Inside Lane (P_L)	0.00	1.00	0.00	1.00	0.00	1.00	0.00	1.00
Lane Grp Cap (c), veh/h	0	1198	0	694	0	581	0	646
V/C Ratio (X)	0.00	0.05	0.00	0.03	0.00	0.01	0.00	0.04
Avail Cap (c_a), veh/h	0	1198	0	694	0	581	0	646
Upstream Filter (I)	0.00	1.00	0.00	1.00	0.00	1.00	0.00	1.00
Uniform Delay (d1), s/veh	0.0	9.0	0.0	8.5	0.0	9.1	0.0	8.5
Incr Delay (d2), s/veh	0.0	0.1	0.0	0.1	0.0	0.0	0.0	0.1
Initial Q Delay (d3), s/veh	0.0	0.0	0.0	0.0	0.0	0.0	0.0	0.0
Control Delay (d), s/veh	0.0	9.0	0.0	8.6	0.0	9.1	0.0	8.7
1st-Term Q (Q1), veh/ln	0.0	0.2	0.0	0.2	0.0	0.0	0.0	0.2
2nd-Term Q (Q2), veh/ln	0.0	0.0	0.0	0.0	0.0	0.0	0.0	0.0
3rd-Term Q (Q3), veh/ln	0.0	0.0	0.0	0.0	0.0	0.0	0.0	0.0
%ile Back of Q Factor (f_B%)	0.00	1.00	0.00	1.00	0.00	1.00	0.00	1.00
%ile Back of Q (50%), veh/ln	0.0	0.2	0.0	0.2	0.0	0.0	0.0	0.2
%ile Storage Ratio (RQ%)	0.00	0.00	0.00	0.00	0.00	0.00	0.00	0.00
Initial Q (Qb), veh	0.0	0.0	0.0	0.0	0.0	0.0	0.0	0.0
Final (Residual) Q (Qe), veh	0.0	0.0	0.0	0.0	0.0	0.0	0.0	0.0
Sat Delay (ds), s/veh	0.0	0.0	0.0	0.0	0.0	0.0	0.0	0.0
Sat Q (Qs), veh	0.0	0.0	0.0	0.0	0.0	0.0	0.0	0.0
Sat Cap (cs), veh/h	0	0	0	0	0	0	0	0
Initial Q Clear Time (tc), h	0.0	0.0	0.0	0.0	0.0	0.0	0.0	0.0
Middle Lane Group Data								
Assigned Mvmt	0	2	0	4	0	6	0	8
Lane Assignment		T		T		T		T
Lanes in Grp	0	2	0	1	0	2	0	1
Grp Vol (v), veh/h	0	191	0	27	0	134	0	28
Grp Sat Flow (s), veh/h/ln	0	1770	0	1863	0	1770	0	1863
Q Serve Time (g_s), s	0.0	1.5	0.0	0.4	0.0	1.1	0.0	0.4
Cycle Q Clear Time (g_c), s	0.0	1.5	0.0	0.4	0.0	1.1	0.0	0.4
Lane Grp Cap (c), veh/h	0	1416	0	745	0	1416	0	745
V/C Ratio (X)	0.00	0.13	0.00	0.04	0.00	0.09	0.00	0.04
Avail Cap (c_a), veh/h	0	1416	0	745	0	1416	0	745
Upstream Filter (I)	0.00	1.00	0.00	1.00	0.00	1.00	0.00	1.00
Uniform Delay (d1), s/veh	0.0	8.6	0.0	8.2	0.0	8.4	0.0	8.2
Incr Delay (d2), s/veh	0.0	0.2	0.0	0.1	0.0	0.1	0.0	0.1
Initial Q Delay (d3), s/veh	0.0	0.0	0.0	0.0	0.0	0.0	0.0	0.0
Control Delay (d), s/veh	0.0	8.8	0.0	8.3	0.0	8.6	0.0	8.3
1st-Term Q (Q1), veh/ln	0.0	0.7	0.0	0.2	0.0	0.5	0.0	0.2

Baseline

Synchro 10 Report
 Page 2

PC ORIGINAL PKG

HCM 2010 Signalized Intersection Capacity Analysis
 12: CA 7 & CA 98

01/07/2021

2nd-Term Q (Q2), veh/ln	0.0	0.0	0.0	0.0	0.0	0.0	0.0	0.0
3rd-Term Q (Q3), veh/ln	0.0	0.0	0.0	0.0	0.0	0.0	0.0	0.0
%ile Back of Q Factor (f_B%)	0.00	1.00	0.00	1.00	0.00	1.00	0.00	1.00
%ile Back of Q (50%), veh/ln	0.0	0.8	0.0	0.2	0.0	0.5	0.0	0.2
%ile Storage Ratio (RQ%)	0.00	0.01	0.00	0.00	0.00	0.02	0.00	0.00
Initial Q (Qb), veh	0.0	0.0	0.0	0.0	0.0	0.0	0.0	0.0
Final (Residual) Q (Qe), veh	0.0	0.0	0.0	0.0	0.0	0.0	0.0	0.0
Sat Delay (ds), s/veh	0.0	0.0	0.0	0.0	0.0	0.0	0.0	0.0
Sat Q (Qs), veh	0.0	0.0	0.0	0.0	0.0	0.0	0.0	0.0
Sat Cap (cs), veh/h	0	0	0	0	0	0	0	0
Initial Q Clear Time (tc), h	0.0	0.0	0.0	0.0	0.0	0.0	0.0	0.0

Right Lane Group Data

























Assigned Mvmt	0	12	0	14	0	16	0	18
Lane Assignment		R		R		R		R
Lanes in Grp	0	1	0	2	0	1	0	1
Grp Vol (v), veh/h	0	34	0	115	0	43	0	9
Grp Sat Flow (s), veh/h/ln	0	1583	0	1393	0	1583	0	1583
Q Serve Time (g_s), s	0.0	0.6	0.0	1.2	0.0	0.8	0.0	0.2
Cycle Q Clear Time (g_c), s	0.0	0.6	0.0	1.2	0.0	0.8	0.0	0.2
Prot RT Sat Flow (s_R), veh/h/ln	0.0	0.0	0.0	0.0	0.0	0.0	0.0	0.0
Prot RT Eff Green (g_R), s	0.0	0.0	0.0	0.0	0.0	0.0	0.0	0.0
Prop RT Outside Lane (P_R)	0.00	1.00	0.00	1.00	0.00	1.00	0.00	1.00
Lane Grp Cap (c), veh/h	0	633	0	1115	0	633	0	633
V/C Ratio (X)	0.00	0.05	0.00	0.10	0.00	0.07	0.00	0.01
Avail Cap (c_a), veh/h	0	633	0	1115	0	633	0	633
Upstream Filter (I)	0.00	1.00	0.00	1.00	0.00	1.00	0.00	1.00
Uniform Delay (d1), s/veh	0.0	8.3	0.0	8.4	0.0	8.3	0.0	8.1
Incr Delay (d2), s/veh	0.0	0.2	0.0	0.2	0.0	0.2	0.0	0.0
Initial Q Delay (d3), s/veh	0.0	0.0	0.0	0.0	0.0	0.0	0.0	0.0
Control Delay (d), s/veh	0.0	8.4	0.0	8.6	0.0	8.5	0.0	8.2
1st-Term Q (Q1), veh/ln	0.0	0.3	0.0	0.4	0.0	0.3	0.0	0.1
2nd-Term Q (Q2), veh/ln	0.0	0.0	0.0	0.0	0.0	0.0	0.0	0.0
3rd-Term Q (Q3), veh/ln	0.0	0.0	0.0	0.0	0.0	0.0	0.0	0.0
%ile Back of Q Factor (f_B%)	0.00	1.00	0.00	1.00	0.00	1.00	0.00	1.00
%ile Back of Q (50%), veh/ln	0.0	0.3	0.0	0.5	0.0	0.4	0.0	0.1
%ile Storage Ratio (RQ%)	0.00	0.00	0.00	0.00	0.00	0.01	0.00	0.00
Initial Q (Qb), veh	0.0	0.0	0.0	0.0	0.0	0.0	0.0	0.0
Final (Residual) Q (Qe), veh	0.0	0.0	0.0	0.0	0.0	0.0	0.0	0.0
Sat Delay (ds), s/veh	0.0	0.0	0.0	0.0	0.0	0.0	0.0	0.0
Sat Q (Qs), veh	0.0	0.0	0.0	0.0	0.0	0.0	0.0	0.0
Sat Cap (cs), veh/h	0	0	0	0	0	0	0	0
Initial Q Clear Time (tc), h	0.0	0.0	0.0	0.0	0.0	0.0	0.0	0.0

Intersection Summary

HCM 2010 Ctrl Delay	8.6
HCM 2010 LOS	A

HCM 2010 Signalized Intersection Capacity Analysis
 12: CA 7 & CA 98

12/15/2021

												
Movement	EBL	EBT	EBR	WBL	WBT	WBR	NBL	NBT	NBR	SBL	SBT	SBR
Lane Configurations												
Traffic Volume (veh/h)	36	52	98	14	103	9	94	106	17	0	64	62
Future Volume (veh/h)	36	52	98	14	103	9	94	106	17	0	64	62
Number	7	4	14	3	8	18	5	2	12	1	6	16
Initial Q, veh	0	0	0	0	0	0	0	0	0	0	0	0
Ped-Bike Adj (A_pbT)	1.00		1.00	1.00		1.00	1.00		1.00	1.00		1.00
Parking Bus Adj	1.00	1.00	1.00	1.00	1.00	1.00	1.00	1.00	1.00	1.00	1.00	1.00
Adj Sat Flow, veh/h/ln	1863	1863	1863	1863	1863	1863	1863	1863	1863	1863	1863	1863
Adj Flow Rate, veh/h	39	57	107	15	112	10	102	115	18	0	70	67
Adj No. of Lanes	1	1	2	1	1	1	2	2	1	1	2	1
Peak Hour Factor	0.92	0.92	0.92	0.92	0.92	0.92	0.92	0.92	0.92	0.92	0.92	0.92
Percent Heavy Veh, %	2	2	2	2	2	2	2	2	2	2	2	2
Opposing Right Turn Influence	Yes			Yes			Yes			Yes		
Cap, veh/h	617	745	1115	624	745	633	1258	1416	633	160	1416	633
HCM Platoon Ratio	1.00	1.00	1.00	1.00	1.00	1.00	1.00	1.00	1.00	1.00	1.00	1.00
Prop Arrive On Green	0.40	0.40	0.40	0.40	0.40	0.40	0.40	0.40	0.40	0.00	0.40	0.40
Ln Grp Delay, s/veh	9.7	8.6	8.6	8.8	9.0	8.2	8.9	8.5	8.3	0.0	8.3	8.8
Ln Grp LOS	A	A	A	A	A	A	A	A	A		A	A
Approach Vol, veh/h		203			137			235			137	
Approach Delay, s/veh		8.8			9.0			8.7			8.6	
Approach LOS		A			A			A			A	
Timer:		1	2	3	4	5	6	7	8			
Assigned Phs			2		4		6		8			
Case No			5.0		5.0		5.0		5.0			
Phs Duration (G+Y+Rc), s			22.5		22.5		22.5		22.5			
Change Period (Y+Rc), s			4.5		4.5		4.5		4.5			
Max Green (Gmax), s			18.0		18.0		18.0		18.0			
Max Allow Headway (MAH), s			4.7		4.4		4.7		5.0			
Max Q Clear (g_c+I1), s			3.8		4.6		3.2		3.7			
Green Ext Time (g_e), s			0.9		0.6		0.5		0.5			
Prob of Phs Call (p_c)			1.00		1.00		1.00		1.00			
Prob of Max Out (p_x)			0.00		0.00		0.00		0.00			
Left-Turn Movement Data												
Assigned Mvmt			5		7		1		3			
Mvmt Sat Flow, veh/h			2419		1264		1252		1217			
Through Movement Data												
Assigned Mvmt			2		4		6		8			
Mvmt Sat Flow, veh/h			3539		1863		3539		1863			
Right-Turn Movement Data												
Assigned Mvmt			12		14		16		18			
Mvmt Sat Flow, veh/h			1583		2787		1583		1583			
Left Lane Group Data												
Assigned Mvmt		0	5	0	7	0	1	0	3			
Lane Assignment												

HCM 2010 Signalized Intersection Capacity Analysis
 12: CA 7 & CA 98

12/15/2021

Lanes in Grp	0	2	0	1	0	1	0	1
Grp Vol (v), veh/h	0	102	0	39	0	0	0	15
Grp Sat Flow (s), veh/h/ln	0	1210	0	1264	0	1252	0	1217
Q Serve Time (g_s), s	0.0	1.2	0.0	0.9	0.0	0.0	0.0	0.3
Cycle Q Clear Time (g_c), s	0.0	1.8	0.0	2.6	0.0	0.0	0.0	1.2
Perm LT Sat Flow (s_l), veh/h/ln	0	1210	0	1264	0	1252	0	1217
Shared LT Sat Flow (s_sh), veh/h/ln	0	0	0	0	0	0	0	0
Perm LT Eff Green (g_p), s	0.0	18.0	0.0	18.0	0.0	0.0	0.0	18.0
Perm LT Serve Time (g_u), s	0.0	17.5	0.0	16.3	0.0	0.0	0.0	17.1
Perm LT Q Serve Time (g_ps), s	0.0	1.2	0.0	0.9	0.0	0.0	0.0	0.3
Time to First Blk (g_f), s	0.0	0.0	0.0	0.0	0.0	0.0	0.0	0.0
Serve Time pre Blk (g_fs), s	0.0	0.0	0.0	0.0	0.0	0.0	0.0	0.0
Prop LT Inside Lane (P_L)	0.00	1.00	0.00	1.00	0.00	1.00	0.00	1.00
Lane Grp Cap (c), veh/h	0	1258	0	617	0	160	0	624
V/C Ratio (X)	0.00	0.08	0.00	0.06	0.00	0.00	0.00	0.02
Avail Cap (c_a), veh/h	0	1258	0	617	0	160	0	624
Upstream Filter (I)	0.00	1.00	0.00	1.00	0.00	0.00	0.00	1.00
Uniform Delay (d1), s/veh	0.0	8.8	0.0	9.5	0.0	0.0	0.0	8.7
Incr Delay (d2), s/veh	0.0	0.1	0.0	0.2	0.0	0.0	0.0	0.1
Initial Q Delay (d3), s/veh	0.0	0.0	0.0	0.0	0.0	0.0	0.0	0.0
Control Delay (d), s/veh	0.0	8.9	0.0	9.7	0.0	0.0	0.0	8.8
1st-Term Q (Q1), veh/ln	0.0	0.4	0.0	0.3	0.0	0.0	0.0	0.1
2nd-Term Q (Q2), veh/ln	0.0	0.0	0.0	0.0	0.0	0.0	0.0	0.0
3rd-Term Q (Q3), veh/ln	0.0	0.0	0.0	0.0	0.0	0.0	0.0	0.0
%ile Back of Q Factor (f_B%)	0.00	1.00	0.00	1.00	0.00	1.00	0.00	1.00
%ile Back of Q (50%), veh/ln	0.0	0.4	0.0	0.3	0.0	0.0	0.0	0.1
%ile Storage Ratio (RQ%)	0.00	0.01	0.00	0.00	0.00	0.00	0.00	0.00
Initial Q (Qb), veh	0.0	0.0	0.0	0.0	0.0	0.0	0.0	0.0
Final (Residual) Q (Qe), veh	0.0	0.0	0.0	0.0	0.0	0.0	0.0	0.0
Sat Delay (ds), s/veh	0.0	0.0	0.0	0.0	0.0	0.0	0.0	0.0
Sat Q (Qs), veh	0.0	0.0	0.0	0.0	0.0	0.0	0.0	0.0
Sat Cap (cs), veh/h	0	0	0	0	0	0	0	0
Initial Q Clear Time (tc), h	0.0	0.0	0.0	0.0	0.0	0.0	0.0	0.0
Middle Lane Group Data								
Assigned Mvmt	0	2	0	4	0	6	0	8
Lane Assignment		T		T		T		T
Lanes in Grp	0	2	0	1	0	2	0	1
Grp Vol (v), veh/h	0	115	0	57	0	70	0	112
Grp Sat Flow (s), veh/h/ln	0	1770	0	1863	0	1770	0	1863
Q Serve Time (g_s), s	0.0	0.9	0.0	0.9	0.0	0.5	0.0	1.7
Cycle Q Clear Time (g_c), s	0.0	0.9	0.0	0.9	0.0	0.5	0.0	1.7
Lane Grp Cap (c), veh/h	0	1416	0	745	0	1416	0	745
V/C Ratio (X)	0.00	0.08	0.00	0.08	0.00	0.05	0.00	0.15
Avail Cap (c_a), veh/h	0	1416	0	745	0	1416	0	745
Upstream Filter (I)	0.00	1.00	0.00	1.00	0.00	1.00	0.00	1.00
Uniform Delay (d1), s/veh	0.0	8.4	0.0	8.4	0.0	8.3	0.0	8.6
Incr Delay (d2), s/veh	0.0	0.1	0.0	0.2	0.0	0.1	0.0	0.4
Initial Q Delay (d3), s/veh	0.0	0.0	0.0	0.0	0.0	0.0	0.0	0.0
Control Delay (d), s/veh	0.0	8.5	0.0	8.6	0.0	8.3	0.0	9.0
1st-Term Q (Q1), veh/ln	0.0	0.4	0.0	0.4	0.0	0.3	0.0	0.9

Baseline

Synchro 10 Report
 Page 2

PC ORIGINAL PKG

HCM 2010 Signalized Intersection Capacity Analysis
 12: CA 7 & CA 98

12/15/2021

2nd-Term Q (Q2), veh/ln	0.0	0.0	0.0	0.0	0.0	0.0	0.0	0.1
3rd-Term Q (Q3), veh/ln	0.0	0.0	0.0	0.0	0.0	0.0	0.0	0.0
%ile Back of Q Factor (f_B%)	0.00	1.00	0.00	1.00	0.00	1.00	0.00	1.00
%ile Back of Q (50%), veh/ln	0.0	0.5	0.0	0.5	0.0	0.3	0.0	1.0
%ile Storage Ratio (RQ%)	0.00	0.01	0.00	0.00	0.00	0.01	0.00	0.00
Initial Q (Qb), veh	0.0	0.0	0.0	0.0	0.0	0.0	0.0	0.0
Final (Residual) Q (Qe), veh	0.0	0.0	0.0	0.0	0.0	0.0	0.0	0.0
Sat Delay (ds), s/veh	0.0	0.0	0.0	0.0	0.0	0.0	0.0	0.0
Sat Q (Qs), veh	0.0	0.0	0.0	0.0	0.0	0.0	0.0	0.0
Sat Cap (cs), veh/h	0	0	0	0	0	0	0	0
Initial Q Clear Time (tc), h	0.0	0.0	0.0	0.0	0.0	0.0	0.0	0.0

Right Lane Group Data

Assigned Mvmt	0	12	0	14	0	16	0	18
Lane Assignment		R		R		R		R
Lanes in Grp	0	1	0	2	0	1	0	1
Grp Vol (v), veh/h	0	18	0	107	0	67	0	10
Grp Sat Flow (s), veh/h/ln	0	1583	0	1393	0	1583	0	1583
Q Serve Time (g_s), s	0.0	0.3	0.0	1.1	0.0	1.2	0.0	0.2
Cycle Q Clear Time (g_c), s	0.0	0.3	0.0	1.1	0.0	1.2	0.0	0.2
Prot RT Sat Flow (s_R), veh/h/ln	0.0	0.0	0.0	0.0	0.0	0.0	0.0	0.0
Prot RT Eff Green (g_R), s	0.0	0.0	0.0	0.0	0.0	0.0	0.0	0.0
Prop RT Outside Lane (P_R)	0.00	1.00	0.00	1.00	0.00	1.00	0.00	1.00
Lane Grp Cap (c), veh/h	0	633	0	1115	0	633	0	633
V/C Ratio (X)	0.00	0.03	0.00	0.10	0.00	0.11	0.00	0.02
Avail Cap (c_a), veh/h	0	633	0	1115	0	633	0	633
Upstream Filter (I)	0.00	1.00	0.00	1.00	0.00	1.00	0.00	1.00
Uniform Delay (d1), s/veh	0.0	8.2	0.0	8.4	0.0	8.5	0.0	8.2
Incr Delay (d2), s/veh	0.0	0.1	0.0	0.2	0.0	0.3	0.0	0.0
Initial Q Delay (d3), s/veh	0.0	0.0	0.0	0.0	0.0	0.0	0.0	0.0
Control Delay (d), s/veh	0.0	8.3	0.0	8.6	0.0	8.8	0.0	8.2
1st-Term Q (Q1), veh/ln	0.0	0.1	0.0	0.4	0.0	0.5	0.0	0.1
2nd-Term Q (Q2), veh/ln	0.0	0.0	0.0	0.0	0.0	0.1	0.0	0.0
3rd-Term Q (Q3), veh/ln	0.0	0.0	0.0	0.0	0.0	0.0	0.0	0.0
%ile Back of Q Factor (f_B%)	0.00	1.00	0.00	1.00	0.00	1.00	0.00	1.00
%ile Back of Q (50%), veh/ln	0.0	0.1	0.0	0.4	0.0	0.6	0.0	0.1
%ile Storage Ratio (RQ%)	0.00	0.00	0.00	0.00	0.00	0.02	0.00	0.00
Initial Q (Qb), veh	0.0	0.0	0.0	0.0	0.0	0.0	0.0	0.0
Final (Residual) Q (Qe), veh	0.0	0.0	0.0	0.0	0.0	0.0	0.0	0.0
Sat Delay (ds), s/veh	0.0	0.0	0.0	0.0	0.0	0.0	0.0	0.0
Sat Q (Qs), veh	0.0	0.0	0.0	0.0	0.0	0.0	0.0	0.0
Sat Cap (cs), veh/h	0	0	0	0	0	0	0	0
Initial Q Clear Time (tc), h	0.0	0.0	0.0	0.0	0.0	0.0	0.0	0.0

Intersection Summary

HCM 2010 Ctrl Delay	8.7
HCM 2010 LOS	A

Intersection

Int Delay, s/veh 1

Movement	EBL	EBT	EBR	WBL	WBT	WBR	NBL	NBT	NBR	SBL	SBT	SBR
Lane Configurations		↕	↕		↕	↕	↕	↕↕	↕	↕	↕↕	↕
Traffic Vol, veh/h	0	3	5	3	2	13	15	196	3	8	158	10
Future Vol, veh/h	0	3	5	3	2	13	15	196	3	8	158	10
Conflicting Peds, #/hr	0	0	0	0	0	0	0	0	0	0	0	0
Sign Control	Stop	Stop	Stop	Stop	Stop	Stop	Free	Free	Free	Free	Free	Free
RT Channelized	-	-	None	-	-	None	-	-	None	-	-	None
Storage Length	-	-	0	-	-	0	0	-	0	0	-	0
Veh in Median Storage, #	-	0	-	-	0	-	-	0	-	-	0	-
Grade, %	-	0	-	-	0	-	-	0	-	-	0	-
Peak Hour Factor	92	92	92	92	92	92	92	92	92	92	92	92
Heavy Vehicles, %	2	2	2	2	2	2	2	2	2	2	2	2
Mvmt Flow	0	3	5	3	2	14	16	213	3	9	172	11

Major/Minor	Minor2		Minor1		Major1			Major2				
Conflicting Flow All	330	438	86	351	446	107	183	0	0	216	0	0
Stage 1	190	190	-	245	245	-	-	-	-	-	-	-
Stage 2	140	248	-	106	201	-	-	-	-	-	-	-
Critical Hdwy	7.54	6.54	6.94	7.54	6.54	6.94	4.14	-	-	4.14	-	-
Critical Hdwy Stg 1	6.54	5.54	-	6.54	5.54	-	-	-	-	-	-	-
Critical Hdwy Stg 2	6.54	5.54	-	6.54	5.54	-	-	-	-	-	-	-
Follow-up Hdwy	3.52	4.02	3.32	3.52	4.02	3.32	2.22	-	-	2.22	-	-
Pot Cap-1 Maneuver	599	511	956	579	506	926	1389	-	-	1351	-	-
Stage 1	794	742	-	737	702	-	-	-	-	-	-	-
Stage 2	849	700	-	888	734	-	-	-	-	-	-	-
Platoon blocked, %								-	-	-	-	-
Mov Cap-1 Maneuver	580	501	956	565	496	926	1389	-	-	1351	-	-
Mov Cap-2 Maneuver	580	501	-	565	496	-	-	-	-	-	-	-
Stage 1	784	737	-	728	694	-	-	-	-	-	-	-
Stage 2	824	692	-	873	729	-	-	-	-	-	-	-

Approach	EB		WB		NB		SB	
HCM Control Delay, s	10.1		9.7		0.5		0.3	
HCM LOS	B		A					

Minor Lane/Major Mvmt	NBL	NBT	NBR	EBLn1	EBLn2	WBLn1	WBLn2	SBL	SBT	SBR
Capacity (veh/h)	1389	-	-	501	956	535	926	1351	-	-
HCM Lane V/C Ratio	0.012	-	-	0.007	0.006	0.01	0.015	0.006	-	-
HCM Control Delay (s)	7.6	-	-	12.2	8.8	11.8	8.9	7.7	-	-
HCM Lane LOS	A	-	-	B	A	B	A	A	-	-
HCM 95th %tile Q(veh)	0	-	-	0	0	0	0	0	-	-

Intersection												
Int Delay, s/veh	2											
Movement	EBL	EBT	EBR	WBL	WBT	WBR	NBL	NBT	NBR	SBL	SBT	SBR
Lane Configurations		↕	↗		↕	↗	↖	↕	↖	↖	↕	↗
Traffic Vol, veh/h	8	3	14	2	7	14	17	135	0	6	107	10
Future Vol, veh/h	8	3	14	2	7	14	17	135	0	6	107	10
Conflicting Peds, #/hr	0	0	0	0	0	0	0	0	0	0	0	0
Sign Control	Stop	Stop	Stop	Stop	Stop	Stop	Free	Free	Free	Free	Free	Free
RT Channelized	-	-	None	-	-	None	-	-	None	-	-	None
Storage Length	-	-	0	-	-	0	0	-	0	0	-	0
Veh in Median Storage, #	-	0	-	-	0	-	-	0	-	-	0	-
Grade, %	-	0	-	-	0	-	-	0	-	-	0	-
Peak Hour Factor	92	92	92	92	92	92	92	92	92	92	92	92
Heavy Vehicles, %	2	2	2	2	2	2	2	2	2	2	2	2
Mvmt Flow	9	3	15	2	8	15	18	147	0	7	116	11

Major/Minor	Minor2		Minor1		Major1			Major2				
Conflicting Flow All	244	313	58	257	324	74	127	0	0	147	0	0
Stage 1	130	130	-	183	183	-	-	-	-	-	-	-
Stage 2	114	183	-	74	141	-	-	-	-	-	-	-
Critical Hdwy	7.54	6.54	6.94	7.54	6.54	6.94	4.14	-	-	4.14	-	-
Critical Hdwy Stg 1	6.54	5.54	-	6.54	5.54	-	-	-	-	-	-	-
Critical Hdwy Stg 2	6.54	5.54	-	6.54	5.54	-	-	-	-	-	-	-
Follow-up Hdwy	3.52	4.02	3.32	3.52	4.02	3.32	2.22	-	-	2.22	-	-
Pot Cap-1 Maneuver	690	601	996	675	592	973	1457	-	-	1432	-	-
Stage 1	860	788	-	801	747	-	-	-	-	-	-	-
Stage 2	879	747	-	927	779	-	-	-	-	-	-	-
Platoon blocked, %								-	-	-	-	-
Mov Cap-1 Maneuver	664	591	996	653	582	973	1457	-	-	1432	-	-
Mov Cap-2 Maneuver	664	591	-	653	582	-	-	-	-	-	-	-
Stage 1	850	784	-	791	738	-	-	-	-	-	-	-
Stage 2	846	738	-	905	775	-	-	-	-	-	-	-

Approach	EB		WB		NB		SB	
HCM Control Delay, s	9.6		9.7		0.8		0.4	
HCM LOS	A		A					

Minor Lane/Major Mvmt	NBL	NBT	NBR	EBLn1	EBLn2	WBLn1	WBLn2	SBL	SBT	SBR
Capacity (veh/h)	1457	-	-	642	996	596	973	1432	-	-
HCM Lane V/C Ratio	0.013	-	-	0.019	0.015	0.016	0.016	0.005	-	-
HCM Control Delay (s)	7.5	-	-	10.7	8.7	11.1	8.8	7.5	-	-
HCM Lane LOS	A	-	-	B	A	B	A	A	-	-
HCM 95th %tile Q(veh)	0	-	-	0.1	0	0.1	0	0	-	-

Intersection												
Int Delay, s/veh	3.7											
Movement	EBL	EBT	EBR	WBL	WBT	WBR	NBL	NBT	NBR	SBL	SBT	SBR
Lane Configurations		↔						↑↑	↑		↑	
Traffic Vol, veh/h	121	0	26	0	0	0	0	206	1	1	56	0
Future Vol, veh/h	121	0	26	0	0	0	0	206	1	1	56	0
Conflicting Peds, #/hr	0	0	0	0	0	0	0	0	0	0	0	0
Sign Control	Stop	Stop	Stop	Free	Free	Free	Free	Free	Free	Free	Free	Free
RT Channelized	-	-	None	-	-	None	-	-	None	-	-	None
Storage Length	-	-	-	-	-	-	-	-	0	-	-	-
Veh in Median Storage, #	-	0	-	-	-	-	-	0	-	-	0	-
Grade, %	-	0	-	-	0	-	-	0	-	-	0	-
Peak Hour Factor	92	92	92	92	92	92	92	92	92	92	92	92
Heavy Vehicles, %	2	2	2	2	2	2	2	2	2	2	2	2
Mvmt Flow	132	0	28	0	0	0	0	224	1	1	61	0

Major/Minor	Minor2			Major1			Major2		
Conflicting Flow All	175	288	61	-	0	0	225	0	0
Stage 1	63	63	-	-	-	-	-	-	-
Stage 2	112	225	-	-	-	-	-	-	-
Critical Hdwy	6.63	6.53	6.23	-	-	-	4.13	-	-
Critical Hdwy Stg 1	5.43	5.53	-	-	-	-	-	-	-
Critical Hdwy Stg 2	5.83	5.53	-	-	-	-	-	-	-
Follow-up Hdwy	3.519	4.019	3.319	-	-	-	2.219	-	-
Pot Cap-1 Maneuver	806	621	1004	0	-	-	1342	-	0
Stage 1	959	842	-	0	-	-	-	-	0
Stage 2	901	717	-	0	-	-	-	-	0
Platoon blocked, %									
Mov Cap-1 Maneuver	805	0	1004	-	-	-	1342	-	-
Mov Cap-2 Maneuver	805	0	-	-	-	-	-	-	-
Stage 1	959	0	-	-	-	-	-	-	-
Stage 2	900	0	-	-	-	-	-	-	-

Approach	EB	NB	SB
HCM Control Delay, s	10.3	0	0.1
HCM LOS	B		

Minor Lane/Major Mvmt	NBT	NBR	EBLn1	SBL	SBT
Capacity (veh/h)	-	-	834	1342	-
HCM Lane V/C Ratio	-	-	0.192	0.001	-
HCM Control Delay (s)	-	-	10.3	7.7	-
HCM Lane LOS	-	-	B	A	-
HCM 95th %tile Q(veh)	-	-	0.7	0	-

Intersection												
Int Delay, s/veh	2.7											
Movement	EBL	EBT	EBR	WBL	WBT	WBR	NBL	NBT	NBR	SBL	SBT	SBR
Lane Configurations		↔						↑↑	↑		↑	
Traffic Vol, veh/h	46	0	49	0	0	0	0	152	9	0	74	0
Future Vol, veh/h	46	0	49	0	0	0	0	152	9	0	74	0
Conflicting Peds, #/hr	0	0	0	0	0	0	0	0	0	0	0	0
Sign Control	Stop	Stop	Stop	Free	Free	Free	Free	Free	Free	Free	Free	Free
RT Channelized	-	-	None	-	-	None	-	-	None	-	-	None
Storage Length	-	-	-	-	-	-	-	-	0	-	-	-
Veh in Median Storage, #	-	0	-	-	-	-	-	0	-	-	0	-
Grade, %	-	0	-	-	0	-	-	0	-	-	0	-
Peak Hour Factor	92	92	92	92	92	92	92	92	92	92	92	92
Heavy Vehicles, %	2	2	2	2	2	2	2	2	2	2	2	2
Mvmt Flow	50	0	53	0	0	0	0	165	10	0	80	0

Major/Minor	Minor2			Major1			Major2		
Conflicting Flow All	163	255	80	-	0	0	-	-	0
Stage 1	80	80	-	-	-	-	-	-	-
Stage 2	83	175	-	-	-	-	-	-	-
Critical Hdwy	6.63	6.53	6.23	-	-	-	-	-	-
Critical Hdwy Stg 1	5.43	5.53	-	-	-	-	-	-	-
Critical Hdwy Stg 2	5.83	5.53	-	-	-	-	-	-	-
Follow-up Hdwy	3.519	4.019	3.319	-	-	-	-	-	-
Pot Cap-1 Maneuver	820	648	980	0	-	-	0	-	0
Stage 1	943	828	-	0	-	-	0	-	0
Stage 2	931	754	-	0	-	-	0	-	0
Platoon blocked, %									
Mov Cap-1 Maneuver	820	0	980	-	-	-	-	-	-
Mov Cap-2 Maneuver	820	0	-	-	-	-	-	-	-
Stage 1	943	0	-	-	-	-	-	-	-
Stage 2	931	0	-	-	-	-	-	-	-

Approach	EB	NB	SB
HCM Control Delay, s	9.5	0	0
HCM LOS	A		

Minor Lane/Major Mvmt	NBT	NBR	EBLn1	SBT
Capacity (veh/h)	-	-	895	-
HCM Lane V/C Ratio	-	-	0.115	-
HCM Control Delay (s)	-	-	9.5	-
HCM Lane LOS	-	-	A	-
HCM 95th %tile Q(veh)	-	-	0.4	-

Intersection												
Int Delay, s/veh	1.2											
Movement	EBL	EBT	EBR	WBL	WBT	WBR	NBL	NBT	NBR	SBL	SBT	SBR
Lane Configurations					↕			↕			↑	↗
Traffic Vol, veh/h	0	0	0	4	0	5	22	89	0	0	58	33
Future Vol, veh/h	0	0	0	4	0	5	22	89	0	0	58	33
Conflicting Peds, #/hr	0	0	0	0	0	0	0	0	0	0	0	0
Sign Control	Free	Free	Free	Stop	Stop	Stop	Free	Free	Free	Free	Free	Free
RT Channelized	-	-	None	-	-	None	-	-	None	-	-	None
Storage Length	-	-	-	-	-	-	-	-	-	-	-	0
Veh in Median Storage, #	-	-	-	-	0	-	-	0	-	-	0	-
Grade, %	-	0	-	-	0	-	-	0	-	-	0	-
Peak Hour Factor	92	92	92	92	92	92	92	92	92	92	92	92
Heavy Vehicles, %	2	2	2	2	2	2	2	2	2	2	2	2
Mvmt Flow	0	0	0	4	0	5	24	97	0	0	63	36

Major/Minor	Minor1		Major1		Major2		
Conflicting Flow All	226	244	97	99	0	-	0
Stage 1	145	145	-	-	-	-	-
Stage 2	81	99	-	-	-	-	-
Critical Hdwy	6.42	6.52	6.22	4.12	-	-	-
Critical Hdwy Stg 1	5.42	5.52	-	-	-	-	-
Critical Hdwy Stg 2	5.42	5.52	-	-	-	-	-
Follow-up Hdwy	3.518	4.018	3.318	2.218	-	-	-
Pot Cap-1 Maneuver	762	658	959	1494	-	0	0
Stage 1	882	777	-	-	-	0	0
Stage 2	942	813	-	-	-	0	0
Platoon blocked, %					-	-	-
Mov Cap-1 Maneuver	749	0	959	1494	-	-	-
Mov Cap-2 Maneuver	749	0	-	-	-	-	-
Stage 1	867	0	-	-	-	-	-
Stage 2	942	0	-	-	-	-	-

Approach	WB	NB	SB
HCM Control Delay, s	9.3	1.5	0
HCM LOS	A		

Minor Lane/Major Mvmt	NBL	NBTWBLn1	SBT	SBR
Capacity (veh/h)	1494	-	853	-
HCM Lane V/C Ratio	0.016	-	0.011	-
HCM Control Delay (s)	7.4	0	9.3	-
HCM Lane LOS	A	A	A	-
HCM 95th %tile Q(veh)	0	-	0	-

Intersection												
Int Delay, s/veh	0.6											
Movement	EBL	EBT	EBR	WBL	WBT	WBR	NBL	NBT	NBR	SBL	SBT	SBR
Lane Configurations					↕			↕			↑	↗
Traffic Vol, veh/h	0	0	0	6	0	4	13	116	76	0	70	47
Future Vol, veh/h	0	0	0	6	0	4	13	116	76	0	70	47
Conflicting Peds, #/hr	0	0	0	0	0	0	0	0	0	0	0	0
Sign Control	Free	Free	Free	Stop	Stop	Stop	Free	Free	Free	Free	Free	Free
RT Channelized	-	-	None	-	-	None	-	-	None	-	-	None
Storage Length	-	-	-	-	-	-	-	-	-	-	-	0
Veh in Median Storage, #	-	-	-	-	0	-	-	0	-	-	0	-
Grade, %	-	0	-	-	0	-	-	0	-	-	0	-
Peak Hour Factor	92	92	92	92	92	92	92	92	92	92	92	92
Heavy Vehicles, %	2	2	2	2	2	2	2	2	2	2	2	2
Mvmt Flow	0	0	0	7	0	4	14	126	83	0	76	51

Major/Minor	Minor1		Major1		Major2		
Conflicting Flow All	298	323	168	127	0	0	-
Stage 1	196	196	-	-	-	-	-
Stage 2	102	127	-	-	-	-	-
Critical Hdwy	6.42	6.52	6.22	4.12	-	-	-
Critical Hdwy Stg 1	5.42	5.52	-	-	-	-	-
Critical Hdwy Stg 2	5.42	5.52	-	-	-	-	-
Follow-up Hdwy	3.518	4.018	3.318	2.218	-	-	-
Pot Cap-1 Maneuver	693	595	876	1459	-	-	0
Stage 1	837	739	-	-	-	-	0
Stage 2	922	791	-	-	-	-	0
Platoon blocked, %					-	-	-
Mov Cap-1 Maneuver	685	0	876	1459	-	-	-
Mov Cap-2 Maneuver	685	0	-	-	-	-	-
Stage 1	828	0	-	-	-	-	-
Stage 2	922	0	-	-	-	-	-

Approach	WB	NB	SB
HCM Control Delay, s	9.9	0.5	0
HCM LOS	A		

Minor Lane/Major Mvmt	NBL	NBT	NBRWBLn1	SBT	SBR
Capacity (veh/h)	1459	-	-	750	-
HCM Lane V/C Ratio	0.01	-	-	0.014	-
HCM Control Delay (s)	7.5	0	-	9.9	-
HCM Lane LOS	A	A	-	A	-
HCM 95th %tile Q(veh)	0	-	-	0	-

APPENDIX C : CONSTRUCTION YEAR PROJECT ANALYSIS WORKSHEETS

Intersection						
Int Delay, s/veh	0					
Movement	EBT	EBR	WBL	WBT	NBL	NBR
Lane Configurations						
Traffic Vol, veh/h	64	0	0	57	0	0
Future Vol, veh/h	64	0	0	57	0	0
Conflicting Peds, #/hr	0	0	0	0	0	0
Sign Control	Free	Free	Free	Free	Stop	Stop
RT Channelized	-	None	-	None	-	None
Storage Length	-	-	-	-	0	-
Veh in Median Storage, #	0	-	-	0	0	-
Grade, %	0	-	-	0	0	-
Peak Hour Factor	92	92	92	92	92	92
Heavy Vehicles, %	2	2	2	2	2	2
Mvmt Flow	70	0	0	62	0	0

Major/Minor	Major1	Major2	Minor1	Minor2	Minor3
Conflicting Flow All	0	0	70	0	132
Stage 1	-	-	-	-	70
Stage 2	-	-	-	-	62
Critical Hdwy	-	-	4.12	-	6.42
Critical Hdwy Stg 1	-	-	-	-	5.42
Critical Hdwy Stg 2	-	-	-	-	5.42
Follow-up Hdwy	-	-	2.218	-	3.518
Pot Cap-1 Maneuver	-	-	1531	-	862
Stage 1	-	-	-	-	953
Stage 2	-	-	-	-	961
Platoon blocked, %	-	-	-	-	-
Mov Cap-1 Maneuver	-	-	1531	-	862
Mov Cap-2 Maneuver	-	-	-	-	862
Stage 1	-	-	-	-	953
Stage 2	-	-	-	-	961

Approach	EB	WB	NB
HCM Control Delay, s	0	0	0
HCM LOS			A

Minor Lane/Major Mvmt	NBLn1	EBT	EBR	WBL	WBT
Capacity (veh/h)	-	-	-	1531	-
HCM Lane V/C Ratio	-	-	-	-	-
HCM Control Delay (s)	0	-	-	0	-
HCM Lane LOS	A	-	-	A	-
HCM 95th %tile Q(veh)	-	-	-	0	-

Intersection						
Int Delay, s/veh	0					
Movement	EBT	EBR	WBL	WBT	NBL	NBR
Lane Configurations						
Traffic Vol, veh/h	70	0	0	87	0	0
Future Vol, veh/h	70	0	0	87	0	0
Conflicting Peds, #/hr	0	0	0	0	0	0
Sign Control	Free	Free	Free	Free	Stop	Stop
RT Channelized	-	None	-	None	-	None
Storage Length	-	-	-	-	0	-
Veh in Median Storage, #	0	-	-	0	0	-
Grade, %	0	-	-	0	0	-
Peak Hour Factor	92	92	92	92	92	92
Heavy Vehicles, %	2	2	2	2	2	2
Mvmt Flow	76	0	0	95	0	0

Major/Minor	Major1	Major2	Minor1	Minor2	Minor3
Conflicting Flow All	0	0	76	0	171
Stage 1	-	-	-	-	76
Stage 2	-	-	-	-	95
Critical Hdwy	-	-	4.12	-	6.42
Critical Hdwy Stg 1	-	-	-	-	5.42
Critical Hdwy Stg 2	-	-	-	-	5.42
Follow-up Hdwy	-	-	2.218	-	3.518
Pot Cap-1 Maneuver	-	-	1523	-	819
Stage 1	-	-	-	-	947
Stage 2	-	-	-	-	929
Platoon blocked, %	-	-	-	-	-
Mov Cap-1 Maneuver	-	-	1523	-	819
Mov Cap-2 Maneuver	-	-	-	-	819
Stage 1	-	-	-	-	947
Stage 2	-	-	-	-	929

Approach	EB	WB	NB
HCM Control Delay, s	0	0	0
HCM LOS			A

Minor Lane/Major Mvmt	NBLn1	EBT	EBR	WBL	WBT
Capacity (veh/h)	-	-	-	1523	-
HCM Lane V/C Ratio	-	-	-	-	-
HCM Control Delay (s)	0	-	-	0	-
HCM Lane LOS	A	-	-	A	-
HCM 95th %tile Q(veh)	-	-	-	0	-

Intersection						
Int Delay, s/veh	1.3					
Movement	EBL	EBT	WBT	WBR	SBL	SBR
Lane Configurations	↖	↑	↗		↖	↗
Traffic Vol, veh/h	11	65	57	7	6	7
Future Vol, veh/h	11	65	57	7	6	7
Conflicting Peds, #/hr	0	0	0	0	0	0
Sign Control	Free	Free	Free	Free	Stop	Stop
RT Channelized	-	None	-	None	-	None
Storage Length	0	-	-	-	0	0
Veh in Median Storage, #	-	0	0	-	0	-
Grade, %	-	0	0	-	0	-
Peak Hour Factor	92	92	92	92	92	92
Heavy Vehicles, %	2	2	2	2	2	2
Mvmt Flow	12	71	62	8	7	8

Major/Minor	Major1	Major2	Minor2		
Conflicting Flow All	70	0	-	0	161
Stage 1	-	-	-	-	66
Stage 2	-	-	-	-	95
Critical Hdwy	4.12	-	-	-	6.42
Critical Hdwy Stg 1	-	-	-	-	5.42
Critical Hdwy Stg 2	-	-	-	-	5.42
Follow-up Hdwy	2.218	-	-	-	3.518
Pot Cap-1 Maneuver	1531	-	-	-	830
Stage 1	-	-	-	-	957
Stage 2	-	-	-	-	929
Platoon blocked, %		-	-	-	
Mov Cap-1 Maneuver	1531	-	-	-	823
Mov Cap-2 Maneuver	-	-	-	-	823
Stage 1	-	-	-	-	949
Stage 2	-	-	-	-	929

Approach	EB	WB	SB
HCM Control Delay, s	1.1	0	9
HCM LOS			A

Minor Lane/Major Mvmt	EBL	EBT	WBT	WBR	SBLn1	SBLn2
Capacity (veh/h)	1531	-	-	-	823	998
HCM Lane V/C Ratio	0.008	-	-	-	0.008	0.008
HCM Control Delay (s)	7.4	-	-	-	9.4	8.6
HCM Lane LOS	A	-	-	-	A	A
HCM 95th %tile Q(veh)	0	-	-	-	0	0

Intersection						
Int Delay, s/veh	1.1					
Movement	EBL	EBT	WBT	WBR	SBL	SBR
Lane Configurations	↙	↑	↘		↙	↘
Traffic Vol, veh/h	5	70	87	11	2	18
Future Vol, veh/h	5	70	87	11	2	18
Conflicting Peds, #/hr	0	0	0	0	0	0
Sign Control	Free	Free	Free	Free	Stop	Stop
RT Channelized	-	None	-	None	-	None
Storage Length	0	-	-	-	0	0
Veh in Median Storage, #	-	0	0	-	0	-
Grade, %	-	0	0	-	0	-
Peak Hour Factor	92	92	92	92	92	92
Heavy Vehicles, %	2	2	2	2	2	2
Mvmt Flow	5	76	95	12	2	20

























Major/Minor	Major1	Major2	Minor2
Conflicting Flow All	107	0	0 187 101
Stage 1	-	-	- 101 -
Stage 2	-	-	- 86 -
Critical Hdwy	4.12	-	- 6.42 6.22
Critical Hdwy Stg 1	-	-	- 5.42 -
Critical Hdwy Stg 2	-	-	- 5.42 -
Follow-up Hdwy	2.218	-	- 3.518 3.318
Pot Cap-1 Maneuver	1484	-	- 802 954
Stage 1	-	-	- 923 -
Stage 2	-	-	- 937 -
Platoon blocked, %		-	-
Mov Cap-1 Maneuver	1484	-	- 800 954
Mov Cap-2 Maneuver	-	-	- 800 -
Stage 1	-	-	- 920 -
Stage 2	-	-	- 937 -

Approach	EB	WB	SB
HCM Control Delay, s	0.5	0	9
HCM LOS			A

Minor Lane/Major Mvmt	EBL	EBT	WBT	WBR	SBLn1	SBLn2
Capacity (veh/h)	1484	-	-	-	800	954
HCM Lane V/C Ratio	0.004	-	-	-	0.003	0.021
HCM Control Delay (s)	7.4	-	-	-	9.5	8.9
HCM Lane LOS	A	-	-	-	A	A
HCM 95th %tile Q(veh)	0	-	-	-	0	0.1

HCM 2010 Signalized Intersection Capacity Analysis
12: CA 7 & CA 98

01/07/2021

												
Movement	EBL	EBT	EBR	WBL	WBT	WBR	NBL	NBT	NBR	SBL	SBT	SBR
Lane Configurations												
Traffic Volume (veh/h)	22	26	112	28	27	8	56	186	33	4	130	42
Future Volume (veh/h)	22	26	112	28	27	8	56	186	33	4	130	42
Number	7	4	14	3	8	18	5	2	12	1	6	16
Initial Q, veh	0	0	0	0	0	0	0	0	0	0	0	0
Ped-Bike Adj (A_pbT)	1.00		1.00	1.00		1.00	1.00		1.00	1.00		1.00
Parking Bus Adj	1.00	1.00	1.00	1.00	1.00	1.00	1.00	1.00	1.00	1.00	1.00	1.00
Adj Sat Flow, veh/h/ln	1863	1863	1863	1863	1863	1863	1863	1863	1863	1863	1863	1863
Adj Flow Rate, veh/h	24	28	122	30	29	9	61	202	36	4	141	46
Adj No. of Lanes	1	1	2	1	1	1	2	2	1	1	2	1
Peak Hour Factor	0.92	0.92	0.92	0.92	0.92	0.92	0.92	0.92	0.92	0.92	0.92	0.92
Percent Heavy Veh, %	2	2	2	2	2	2	2	2	2	2	2	2
Opposing Right Turn Influence	Yes			Yes			Yes			Yes		
Cap, veh/h	693	745	1115	642	745	633	1187	1416	633	574	1416	633
HCM Platoon Ratio	1.00	1.00	1.00	1.00	1.00	1.00	1.00	1.00	1.00	1.00	1.00	1.00
Prop Arrive On Green	0.40	0.40	0.40	0.40	0.40	0.40	0.40	0.40	0.40	0.40	0.40	0.40
Ln Grp Delay, s/veh	8.6	8.3	8.7	8.7	8.3	8.2	9.1	8.8	8.5	9.2	8.6	8.6
Ln Grp LOS	A	A	A	A	A	A	A	A	A	A	A	A
Approach Vol, veh/h		174			68			299			191	
Approach Delay, s/veh		8.6			8.5			8.8			8.6	
Approach LOS		A			A			A			A	
Timer:		1	2	3	4	5	6	7	8			
Assigned Phs			2		4		6		8			
Case No			5.0		5.0		5.0		5.0			
Phs Duration (G+Y+Rc), s			22.5		22.5		22.5		22.5			
Change Period (Y+Rc), s			4.5		4.5		4.5		4.5			
Max Green (Gmax), s			18.0		18.0		18.0		18.0			
Max Allow Headway (MAH), s			4.9		4.2		4.9		4.6			
Max Q Clear (g_c+I1), s			3.9		3.2		3.7		3.1			
Green Ext Time (g_e), s			1.3		0.5		0.8		0.2			
Prob of Phs Call (p_c)			1.00		1.00		1.00		1.00			
Prob of Max Out (p_x)			0.00		0.00		0.00		0.00			
Left-Turn Movement Data												
Assigned Mvmt			5		7		1		3			
Mvmt Sat Flow, veh/h			2312		1364		1138		1232			
Through Movement Data												
Assigned Mvmt			2		4		6		8			
Mvmt Sat Flow, veh/h			3539		1863		3539		1863			
Right-Turn Movement Data												
Assigned Mvmt			12		14		16		18			
Mvmt Sat Flow, veh/h			1583		2787		1583		1583			
Left Lane Group Data												
Assigned Mvmt		0	5	0	7	0	1	0	3			
Lane Assignment												

HCM 2010 Signalized Intersection Capacity Analysis
 12: CA 7 & CA 98

01/07/2021

Lanes in Grp	0	2	0	1	0	1	0	1
Grp Vol (v), veh/h	0	61	0	24	0	4	0	30
Grp Sat Flow (s), veh/h/ln	0	1156	0	1364	0	1138	0	1232
Q Serve Time (g_s), s	0.0	0.8	0.0	0.5	0.0	0.1	0.0	0.7
Cycle Q Clear Time (g_c), s	0.0	1.9	0.0	0.9	0.0	1.7	0.0	1.1
Perm LT Sat Flow (s_l), veh/h/ln	0	1156	0	1364	0	1138	0	1232
Shared LT Sat Flow (s_sh), veh/h/ln	0	0	0	0	0	0	0	0
Perm LT Eff Green (g_p), s	0.0	18.0	0.0	18.0	0.0	18.0	0.0	18.0
Perm LT Serve Time (g_u), s	0.0	16.9	0.0	17.6	0.0	16.4	0.0	17.6
Perm LT Q Serve Time (g_ps), s	0.0	0.8	0.0	0.5	0.0	0.1	0.0	0.7
Time to First Blk (g_f), s	0.0	0.0	0.0	0.0	0.0	0.0	0.0	0.0
Serve Time pre Blk (g_fs), s	0.0	0.0	0.0	0.0	0.0	0.0	0.0	0.0
Prop LT Inside Lane (P_L)	0.00	1.00	0.00	1.00	0.00	1.00	0.00	1.00
Lane Grp Cap (c), veh/h	0	1187	0	693	0	574	0	642
V/C Ratio (X)	0.00	0.05	0.00	0.03	0.00	0.01	0.00	0.05
Avail Cap (c_a), veh/h	0	1187	0	693	0	574	0	642
Upstream Filter (I)	0.00	1.00	0.00	1.00	0.00	1.00	0.00	1.00
Uniform Delay (d1), s/veh	0.0	9.0	0.0	8.5	0.0	9.1	0.0	8.6
Incr Delay (d2), s/veh	0.0	0.1	0.0	0.1	0.0	0.0	0.0	0.1
Initial Q Delay (d3), s/veh	0.0	0.0	0.0	0.0	0.0	0.0	0.0	0.0
Control Delay (d), s/veh	0.0	9.1	0.0	8.6	0.0	9.2	0.0	8.7
1st-Term Q (Q1), veh/ln	0.0	0.2	0.0	0.2	0.0	0.0	0.0	0.2
2nd-Term Q (Q2), veh/ln	0.0	0.0	0.0	0.0	0.0	0.0	0.0	0.0
3rd-Term Q (Q3), veh/ln	0.0	0.0	0.0	0.0	0.0	0.0	0.0	0.0
%ile Back of Q Factor (f_B%)	0.00	1.00	0.00	1.00	0.00	1.00	0.00	1.00
%ile Back of Q (50%), veh/ln	0.0	0.3	0.0	0.2	0.0	0.0	0.0	0.3
%ile Storage Ratio (RQ%)	0.00	0.00	0.00	0.00	0.00	0.00	0.00	0.00
Initial Q (Qb), veh	0.0	0.0	0.0	0.0	0.0	0.0	0.0	0.0
Final (Residual) Q (Qe), veh	0.0	0.0	0.0	0.0	0.0	0.0	0.0	0.0
Sat Delay (ds), s/veh	0.0	0.0	0.0	0.0	0.0	0.0	0.0	0.0
Sat Q (Qs), veh	0.0	0.0	0.0	0.0	0.0	0.0	0.0	0.0
Sat Cap (cs), veh/h	0	0	0	0	0	0	0	0
Initial Q Clear Time (tc), h	0.0	0.0	0.0	0.0	0.0	0.0	0.0	0.0
Middle Lane Group Data								
Assigned Mvmt	0	2	0	4	0	6	0	8
Lane Assignment		T		T		T		T
Lanes in Grp	0	2	0	1	0	2	0	1
Grp Vol (v), veh/h	0	202	0	28	0	141	0	29
Grp Sat Flow (s), veh/h/ln	0	1770	0	1863	0	1770	0	1863
Q Serve Time (g_s), s	0.0	1.6	0.0	0.4	0.0	1.1	0.0	0.4
Cycle Q Clear Time (g_c), s	0.0	1.6	0.0	0.4	0.0	1.1	0.0	0.4
Lane Grp Cap (c), veh/h	0	1416	0	745	0	1416	0	745
V/C Ratio (X)	0.00	0.14	0.00	0.04	0.00	0.10	0.00	0.04
Avail Cap (c_a), veh/h	0	1416	0	745	0	1416	0	745
Upstream Filter (I)	0.00	1.00	0.00	1.00	0.00	1.00	0.00	1.00
Uniform Delay (d1), s/veh	0.0	8.6	0.0	8.2	0.0	8.4	0.0	8.2
Incr Delay (d2), s/veh	0.0	0.2	0.0	0.1	0.0	0.1	0.0	0.1
Initial Q Delay (d3), s/veh	0.0	0.0	0.0	0.0	0.0	0.0	0.0	0.0
Control Delay (d), s/veh	0.0	8.8	0.0	8.3	0.0	8.6	0.0	8.3
1st-Term Q (Q1), veh/ln	0.0	0.8	0.0	0.2	0.0	0.5	0.0	0.2

Baseline

Synchro 10 Report
 Page 2

PC ORIGINAL PKG

HCM 2010 Signalized Intersection Capacity Analysis
 12: CA 7 & CA 98

01/07/2021

2nd-Term Q (Q2), veh/ln	0.0	0.0	0.0	0.0	0.0	0.0	0.0	0.0
3rd-Term Q (Q3), veh/ln	0.0	0.0	0.0	0.0	0.0	0.0	0.0	0.0
%ile Back of Q Factor (f_B%)	0.00	1.00	0.00	1.00	0.00	1.00	0.00	1.00
%ile Back of Q (50%), veh/ln	0.0	0.8	0.0	0.2	0.0	0.6	0.0	0.2
%ile Storage Ratio (RQ%)	0.00	0.01	0.00	0.00	0.00	0.02	0.00	0.00
Initial Q (Qb), veh	0.0	0.0	0.0	0.0	0.0	0.0	0.0	0.0
Final (Residual) Q (Qe), veh	0.0	0.0	0.0	0.0	0.0	0.0	0.0	0.0
Sat Delay (ds), s/veh	0.0	0.0	0.0	0.0	0.0	0.0	0.0	0.0
Sat Q (Qs), veh	0.0	0.0	0.0	0.0	0.0	0.0	0.0	0.0
Sat Cap (cs), veh/h	0	0	0	0	0	0	0	0
Initial Q Clear Time (tc), h	0.0	0.0	0.0	0.0	0.0	0.0	0.0	0.0

Right Lane Group Data

























Assigned Mvmt	0	12	0	14	0	16	0	18
Lane Assignment		R		R		R		R
Lanes in Grp	0	1	0	2	0	1	0	1
Grp Vol (v), veh/h	0	36	0	122	0	46	0	9
Grp Sat Flow (s), veh/h/ln	0	1583	0	1393	0	1583	0	1583
Q Serve Time (g_s), s	0.0	0.6	0.0	1.2	0.0	0.8	0.0	0.2
Cycle Q Clear Time (g_c), s	0.0	0.6	0.0	1.2	0.0	0.8	0.0	0.2
Prot RT Sat Flow (s_R), veh/h/ln	0.0	0.0	0.0	0.0	0.0	0.0	0.0	0.0
Prot RT Eff Green (g_R), s	0.0	0.0	0.0	0.0	0.0	0.0	0.0	0.0
Prop RT Outside Lane (P_R)	0.00	1.00	0.00	1.00	0.00	1.00	0.00	1.00
Lane Grp Cap (c), veh/h	0	633	0	1115	0	633	0	633
V/C Ratio (X)	0.00	0.06	0.00	0.11	0.00	0.07	0.00	0.01
Avail Cap (c_a), veh/h	0	633	0	1115	0	633	0	633
Upstream Filter (I)	0.00	1.00	0.00	1.00	0.00	1.00	0.00	1.00
Uniform Delay (d1), s/veh	0.0	8.3	0.0	8.5	0.0	8.3	0.0	8.1
Incr Delay (d2), s/veh	0.0	0.2	0.0	0.2	0.0	0.2	0.0	0.0
Initial Q Delay (d3), s/veh	0.0	0.0	0.0	0.0	0.0	0.0	0.0	0.0
Control Delay (d), s/veh	0.0	8.5	0.0	8.7	0.0	8.6	0.0	8.2
1st-Term Q (Q1), veh/ln	0.0	0.3	0.0	0.5	0.0	0.3	0.0	0.1
2nd-Term Q (Q2), veh/ln	0.0	0.0	0.0	0.0	0.0	0.0	0.0	0.0
3rd-Term Q (Q3), veh/ln	0.0	0.0	0.0	0.0	0.0	0.0	0.0	0.0
%ile Back of Q Factor (f_B%)	0.00	1.00	0.00	1.00	0.00	1.00	0.00	1.00
%ile Back of Q (50%), veh/ln	0.0	0.3	0.0	0.5	0.0	0.4	0.0	0.1
%ile Storage Ratio (RQ%)	0.00	0.00	0.00	0.00	0.00	0.02	0.00	0.00
Initial Q (Qb), veh	0.0	0.0	0.0	0.0	0.0	0.0	0.0	0.0
Final (Residual) Q (Qe), veh	0.0	0.0	0.0	0.0	0.0	0.0	0.0	0.0
Sat Delay (ds), s/veh	0.0	0.0	0.0	0.0	0.0	0.0	0.0	0.0
Sat Q (Qs), veh	0.0	0.0	0.0	0.0	0.0	0.0	0.0	0.0
Sat Cap (cs), veh/h	0	0	0	0	0	0	0	0
Initial Q Clear Time (tc), h	0.0	0.0	0.0	0.0	0.0	0.0	0.0	0.0

Intersection Summary

HCM 2010 Ctrl Delay	8.7
HCM 2010 LOS	A

HCM 2010 Signalized Intersection Capacity Analysis
 12: CA 7 & CA 98

12/15/2021

												
Movement	EBL	EBT	EBR	WBL	WBT	WBR	NBL	NBT	NBR	SBL	SBT	SBR
Lane Configurations												
Traffic Volume (veh/h)	38	55	103	15	109	9	99	112	18	0	68	65
Future Volume (veh/h)	38	55	103	15	109	9	99	112	18	0	68	65
Number	7	4	14	3	8	18	5	2	12	1	6	16
Initial Q, veh	0	0	0	0	0	0	0	0	0	0	0	0
Ped-Bike Adj (A_pbT)	1.00		1.00	1.00		1.00	1.00		1.00	1.00		1.00
Parking Bus Adj	1.00	1.00	1.00	1.00	1.00	1.00	1.00	1.00	1.00	1.00	1.00	1.00
Adj Sat Flow, veh/h/ln	1863	1863	1863	1863	1863	1863	1863	1863	1863	1863	1863	1863
Adj Flow Rate, veh/h	41	60	112	16	118	10	108	122	20	0	74	71
Adj No. of Lanes	1	1	2	1	1	1	2	2	1	1	2	1
Peak Hour Factor	0.92	0.92	0.92	0.92	0.92	0.92	0.92	0.92	0.92	0.92	0.92	0.92
Percent Heavy Veh, %	2	2	2	2	2	2	2	2	2	2	2	2
Opposing Right Turn Influence	Yes			Yes			Yes			Yes		
Cap, veh/h	612	745	1115	619	745	633	1250	1416	633	160	1416	633
HCM Platoon Ratio	1.00	1.00	1.00	1.00	1.00	1.00	1.00	1.00	1.00	1.00	1.00	1.00
Prop Arrive On Green	0.40	0.40	0.40	0.40	0.40	0.40	0.40	0.40	0.40	0.00	0.40	0.40
Ln Grp Delay, s/veh	9.8	8.6	8.6	8.8	9.1	8.2	9.0	8.5	8.3	0.0	8.3	8.8
Ln Grp LOS	A	A	A	A	A	A	A	A	A		A	A
Approach Vol, veh/h		213			144			250			145	
Approach Delay, s/veh		8.8			9.0			8.7			8.6	
Approach LOS		A			A			A			A	
Timer:		1	2	3	4	5	6	7	8			
Assigned Phs			2		4		6		8			
Case No			5.0		5.0		5.0		5.0			
Phs Duration (G+Y+Rc), s			22.5		22.5		22.5		22.5			
Change Period (Y+Rc), s			4.5		4.5		4.5		4.5			
Max Green (Gmax), s			18.0		18.0		18.0		18.0			
Max Allow Headway (MAH), s			4.7		4.4		4.7		5.0			
Max Q Clear (g_c+I1), s			3.9		4.8		3.3		3.8			
Green Ext Time (g_e), s			1.0		0.7		0.5		0.5			
Prob of Phs Call (p_c)			1.00		1.00		1.00		1.00			
Prob of Max Out (p_x)			0.00		0.00		0.00		0.00			
Left-Turn Movement Data												
Assigned Mvmt			5		7		1		3			
Mvmt Sat Flow, veh/h			2402		1257		1241		1208			
Through Movement Data												
Assigned Mvmt			2		4		6		8			
Mvmt Sat Flow, veh/h			3539		1863		3539		1863			
Right-Turn Movement Data												
Assigned Mvmt			12		14		16		18			
Mvmt Sat Flow, veh/h			1583		2787		1583		1583			
Left Lane Group Data												
Assigned Mvmt		0	5	0	7	0	1	0	3			
Lane Assignment												

HCM 2010 Signalized Intersection Capacity Analysis
 12: CA 7 & CA 98

12/15/2021

Lanes in Grp	0	2	0	1	0	1	0	1
Grp Vol (v), veh/h	0	108	0	41	0	0	0	16
Grp Sat Flow (s), veh/h/ln	0	1201	0	1257	0	1241	0	1208
Q Serve Time (g_s), s	0.0	1.3	0.0	1.0	0.0	0.0	0.0	0.4
Cycle Q Clear Time (g_c), s	0.0	1.9	0.0	2.8	0.0	0.0	0.0	1.3
Perm LT Sat Flow (s_l), veh/h/ln	0	1201	0	1257	0	1241	0	1208
Shared LT Sat Flow (s_sh), veh/h/ln	0	0	0	0	0	0	0	0
Perm LT Eff Green (g_p), s	0.0	18.0	0.0	18.0	0.0	0.0	0.0	18.0
Perm LT Serve Time (g_u), s	0.0	17.4	0.0	16.2	0.0	0.0	0.0	17.1
Perm LT Q Serve Time (g_ps), s	0.0	1.3	0.0	1.0	0.0	0.0	0.0	0.4
Time to First Blk (g_f), s	0.0	0.0	0.0	0.0	0.0	0.0	0.0	0.0
Serve Time pre Blk (g_fs), s	0.0	0.0	0.0	0.0	0.0	0.0	0.0	0.0
Prop LT Inside Lane (P_L)	0.00	1.00	0.00	1.00	0.00	1.00	0.00	1.00
Lane Grp Cap (c), veh/h	0	1250	0	612	0	160	0	619
V/C Ratio (X)	0.00	0.09	0.00	0.07	0.00	0.00	0.00	0.03
Avail Cap (c_a), veh/h	0	1250	0	612	0	160	0	619
Upstream Filter (I)	0.00	1.00	0.00	1.00	0.00	0.00	0.00	1.00
Uniform Delay (d1), s/veh	0.0	8.8	0.0	9.5	0.0	0.0	0.0	8.8
Incr Delay (d2), s/veh	0.0	0.1	0.0	0.2	0.0	0.0	0.0	0.1
Initial Q Delay (d3), s/veh	0.0	0.0	0.0	0.0	0.0	0.0	0.0	0.0
Control Delay (d), s/veh	0.0	9.0	0.0	9.8	0.0	0.0	0.0	8.8
1st-Term Q (Q1), veh/ln	0.0	0.4	0.0	0.3	0.0	0.0	0.0	0.1
2nd-Term Q (Q2), veh/ln	0.0	0.0	0.0	0.0	0.0	0.0	0.0	0.0
3rd-Term Q (Q3), veh/ln	0.0	0.0	0.0	0.0	0.0	0.0	0.0	0.0
%ile Back of Q Factor (f_B%)	0.00	1.00	0.00	1.00	0.00	1.00	0.00	1.00
%ile Back of Q (50%), veh/ln	0.0	0.4	0.0	0.4	0.0	0.0	0.0	0.1
%ile Storage Ratio (RQ%)	0.00	0.01	0.00	0.00	0.00	0.00	0.00	0.00
Initial Q (Qb), veh	0.0	0.0	0.0	0.0	0.0	0.0	0.0	0.0
Final (Residual) Q (Qe), veh	0.0	0.0	0.0	0.0	0.0	0.0	0.0	0.0
Sat Delay (ds), s/veh	0.0	0.0	0.0	0.0	0.0	0.0	0.0	0.0
Sat Q (Qs), veh	0.0	0.0	0.0	0.0	0.0	0.0	0.0	0.0
Sat Cap (cs), veh/h	0	0	0	0	0	0	0	0
Initial Q Clear Time (tc), h	0.0	0.0	0.0	0.0	0.0	0.0	0.0	0.0
Middle Lane Group Data								
Assigned Mvmt	0	2	0	4	0	6	0	8
Lane Assignment		T		T		T		T
Lanes in Grp	0	2	0	1	0	2	0	1
Grp Vol (v), veh/h	0	122	0	60	0	74	0	118
Grp Sat Flow (s), veh/h/ln	0	1770	0	1863	0	1770	0	1863
Q Serve Time (g_s), s	0.0	1.0	0.0	0.9	0.0	0.6	0.0	1.8
Cycle Q Clear Time (g_c), s	0.0	1.0	0.0	0.9	0.0	0.6	0.0	1.8
Lane Grp Cap (c), veh/h	0	1416	0	745	0	1416	0	745
V/C Ratio (X)	0.00	0.09	0.00	0.08	0.00	0.05	0.00	0.16
Avail Cap (c_a), veh/h	0	1416	0	745	0	1416	0	745
Upstream Filter (I)	0.00	1.00	0.00	1.00	0.00	1.00	0.00	1.00
Uniform Delay (d1), s/veh	0.0	8.4	0.0	8.4	0.0	8.3	0.0	8.6
Incr Delay (d2), s/veh	0.0	0.1	0.0	0.2	0.0	0.1	0.0	0.5
Initial Q Delay (d3), s/veh	0.0	0.0	0.0	0.0	0.0	0.0	0.0	0.0
Control Delay (d), s/veh	0.0	8.5	0.0	8.6	0.0	8.3	0.0	9.1
1st-Term Q (Q1), veh/ln	0.0	0.5	0.0	0.4	0.0	0.3	0.0	0.9

Baseline

Synchro 10 Report
 Page 2

PC ORIGINAL PKG

HCM 2010 Signalized Intersection Capacity Analysis
 12: CA 7 & CA 98

12/15/2021

2nd-Term Q (Q2), veh/ln	0.0	0.0	0.0	0.0	0.0	0.0	0.0	0.1
3rd-Term Q (Q3), veh/ln	0.0	0.0	0.0	0.0	0.0	0.0	0.0	0.0
%ile Back of Q Factor (f_B%)	0.00	1.00	0.00	1.00	0.00	1.00	0.00	1.00
%ile Back of Q (50%), veh/ln	0.0	0.5	0.0	0.5	0.0	0.3	0.0	1.0
%ile Storage Ratio (RQ%)	0.00	0.01	0.00	0.00	0.00	0.01	0.00	0.00
Initial Q (Qb), veh	0.0	0.0	0.0	0.0	0.0	0.0	0.0	0.0
Final (Residual) Q (Qe), veh	0.0	0.0	0.0	0.0	0.0	0.0	0.0	0.0
Sat Delay (ds), s/veh	0.0	0.0	0.0	0.0	0.0	0.0	0.0	0.0
Sat Q (Qs), veh	0.0	0.0	0.0	0.0	0.0	0.0	0.0	0.0
Sat Cap (cs), veh/h	0	0	0	0	0	0	0	0
Initial Q Clear Time (tc), h	0.0	0.0	0.0	0.0	0.0	0.0	0.0	0.0

Right Lane Group Data

Assigned Mvmt	0	12	0	14	0	16	0	18
Lane Assignment		R		R		R		R
Lanes in Grp	0	1	0	2	0	1	0	1
Grp Vol (v), veh/h	0	20	0	112	0	71	0	10
Grp Sat Flow (s), veh/h/ln	0	1583	0	1393	0	1583	0	1583
Q Serve Time (g_s), s	0.0	0.3	0.0	1.1	0.0	1.3	0.0	0.2
Cycle Q Clear Time (g_c), s	0.0	0.3	0.0	1.1	0.0	1.3	0.0	0.2
Prot RT Sat Flow (s_R), veh/h/ln	0.0	0.0	0.0	0.0	0.0	0.0	0.0	0.0
Prot RT Eff Green (g_R), s	0.0	0.0	0.0	0.0	0.0	0.0	0.0	0.0
Prop RT Outside Lane (P_R)	0.00	1.00	0.00	1.00	0.00	1.00	0.00	1.00
Lane Grp Cap (c), veh/h	0	633	0	1115	0	633	0	633
V/C Ratio (X)	0.00	0.03	0.00	0.10	0.00	0.11	0.00	0.02
Avail Cap (c_a), veh/h	0	633	0	1115	0	633	0	633
Upstream Filter (I)	0.00	1.00	0.00	1.00	0.00	1.00	0.00	1.00
Uniform Delay (d1), s/veh	0.0	8.2	0.0	8.4	0.0	8.5	0.0	8.2
Incr Delay (d2), s/veh	0.0	0.1	0.0	0.2	0.0	0.4	0.0	0.0
Initial Q Delay (d3), s/veh	0.0	0.0	0.0	0.0	0.0	0.0	0.0	0.0
Control Delay (d), s/veh	0.0	8.3	0.0	8.6	0.0	8.8	0.0	8.2
1st-Term Q (Q1), veh/ln	0.0	0.1	0.0	0.4	0.0	0.6	0.0	0.1
2nd-Term Q (Q2), veh/ln	0.0	0.0	0.0	0.0	0.0	0.1	0.0	0.0
3rd-Term Q (Q3), veh/ln	0.0	0.0	0.0	0.0	0.0	0.0	0.0	0.0
%ile Back of Q Factor (f_B%)	0.00	1.00	0.00	1.00	0.00	1.00	0.00	1.00
%ile Back of Q (50%), veh/ln	0.0	0.2	0.0	0.5	0.0	0.6	0.0	0.1
%ile Storage Ratio (RQ%)	0.00	0.00	0.00	0.00	0.00	0.03	0.00	0.00
Initial Q (Qb), veh	0.0	0.0	0.0	0.0	0.0	0.0	0.0	0.0
Final (Residual) Q (Qe), veh	0.0	0.0	0.0	0.0	0.0	0.0	0.0	0.0
Sat Delay (ds), s/veh	0.0	0.0	0.0	0.0	0.0	0.0	0.0	0.0
Sat Q (Qs), veh	0.0	0.0	0.0	0.0	0.0	0.0	0.0	0.0
Sat Cap (cs), veh/h	0	0	0	0	0	0	0	0
Initial Q Clear Time (tc), h	0.0	0.0	0.0	0.0	0.0	0.0	0.0	0.0

Intersection Summary

HCM 2010 Ctrl Delay	8.8
HCM 2010 LOS	A

Intersection

Int Delay, s/veh 1

Movement	EBL	EBT	EBR	WBL	WBT	WBR	NBL	NBT	NBR	SBL	SBT	SBR
Lane Configurations		↕	↕		↕	↕	↕	↕↕	↕	↕	↕↕	↕
Traffic Vol, veh/h	0	3	5	3	2	14	16	207	3	8	167	11
Future Vol, veh/h	0	3	5	3	2	14	16	207	3	8	167	11
Conflicting Peds, #/hr	0	0	0	0	0	0	0	0	0	0	0	0
Sign Control	Stop	Stop	Stop	Stop	Stop	Stop	Free	Free	Free	Free	Free	Free
RT Channelized	-	-	None	-	-	None	-	-	None	-	-	None
Storage Length	-	-	0	-	-	0	0	-	0	0	-	0
Veh in Median Storage, #	-	0	-	-	0	-	-	0	-	-	0	-
Grade, %	-	0	-	-	0	-	-	0	-	-	0	-
Peak Hour Factor	92	92	92	92	92	92	92	92	92	92	92	92
Heavy Vehicles, %	2	2	2	2	2	2	2	2	2	2	2	2
Mvmt Flow	0	3	5	3	2	15	17	225	3	9	182	12

Major/Minor	Minor2		Minor1		Major1			Major2				
Conflicting Flow All	348	462	91	370	471	113	194	0	0	228	0	0
Stage 1	200	200	-	259	259	-	-	-	-	-	-	-
Stage 2	148	262	-	111	212	-	-	-	-	-	-	-
Critical Hdwy	7.54	6.54	6.94	7.54	6.54	6.94	4.14	-	-	4.14	-	-
Critical Hdwy Stg 1	6.54	5.54	-	6.54	5.54	-	-	-	-	-	-	-
Critical Hdwy Stg 2	6.54	5.54	-	6.54	5.54	-	-	-	-	-	-	-
Follow-up Hdwy	3.52	4.02	3.32	3.52	4.02	3.32	2.22	-	-	2.22	-	-
Pot Cap-1 Maneuver	582	495	949	562	489	918	1377	-	-	1337	-	-
Stage 1	783	735	-	723	692	-	-	-	-	-	-	-
Stage 2	840	690	-	882	726	-	-	-	-	-	-	-
Platoon blocked, %								-	-	-	-	-
Mov Cap-1 Maneuver	562	486	949	548	480	918	1377	-	-	1337	-	-
Mov Cap-2 Maneuver	562	486	-	548	480	-	-	-	-	-	-	-
Stage 1	774	730	-	714	684	-	-	-	-	-	-	-
Stage 2	813	682	-	867	721	-	-	-	-	-	-	-

Approach	EB		WB		NB		SB	
HCM Control Delay, s	10.2		9.8		0.5		0.3	
HCM LOS	B		A					

Minor Lane/Major Mvmt	NBL	NBT	NBR	EBLn1	EBLn2	WBLn1	WBLn2	SBL	SBT	SBR
Capacity (veh/h)	1377	-	-	486	949	519	918	1337	-	-
HCM Lane V/C Ratio	0.013	-	-	0.007	0.006	0.01	0.017	0.007	-	-
HCM Control Delay (s)	7.6	-	-	12.5	8.8	12	9	7.7	-	-
HCM Lane LOS	A	-	-	B	A	B	A	A	-	-
HCM 95th %tile Q(veh)	0	-	-	0	0	0	0.1	0	-	-

Intersection												
Int Delay, s/veh	1.9											
Movement	EBL	EBT	EBR	WBL	WBT	WBR	NBL	NBT	NBR	SBL	SBT	SBR
Lane Configurations		↕	↗		↕	↗	↖	↕	↖	↖	↕	↗
Traffic Vol, veh/h	8	3	15	2	7	15	18	142	0	6	113	11
Future Vol, veh/h	8	3	15	2	7	15	18	142	0	6	113	11
Conflicting Peds, #/hr	0	0	0	0	0	0	0	0	0	0	0	0
Sign Control	Stop	Stop	Stop	Stop	Stop	Stop	Free	Free	Free	Free	Free	Free
RT Channelized	-	-	None	-	-	None	-	-	None	-	-	None
Storage Length	-	-	0	-	-	0	0	-	0	0	-	0
Veh in Median Storage, #	-	0	-	-	0	-	-	0	-	-	0	-
Grade, %	-	0	-	-	0	-	-	0	-	-	0	-
Peak Hour Factor	92	92	92	92	92	92	92	92	92	92	92	92
Heavy Vehicles, %	2	2	2	2	2	2	2	2	2	2	2	2
Mvmt Flow	9	3	16	2	8	16	20	154	0	7	123	12

Major/Minor	Minor2		Minor1			Major1			Major2			
Conflicting Flow All	258	331	62	271	343	77	135	0	0	154	0	0
Stage 1	137	137	-	194	194	-	-	-	-	-	-	-
Stage 2	121	194	-	77	149	-	-	-	-	-	-	-
Critical Hdwy	7.54	6.54	6.94	7.54	6.54	6.94	4.14	-	-	4.14	-	-
Critical Hdwy Stg 1	6.54	5.54	-	6.54	5.54	-	-	-	-	-	-	-
Critical Hdwy Stg 2	6.54	5.54	-	6.54	5.54	-	-	-	-	-	-	-
Follow-up Hdwy	3.52	4.02	3.32	3.52	4.02	3.32	2.22	-	-	2.22	-	-
Pot Cap-1 Maneuver	674	587	990	660	578	968	1447	-	-	1424	-	-
Stage 1	852	782	-	789	739	-	-	-	-	-	-	-
Stage 2	870	739	-	923	773	-	-	-	-	-	-	-
Platoon blocked, %								-	-	-	-	-
Mov Cap-1 Maneuver	646	576	990	637	567	968	1447	-	-	1424	-	-
Mov Cap-2 Maneuver	646	576	-	637	567	-	-	-	-	-	-	-
Stage 1	840	778	-	778	729	-	-	-	-	-	-	-
Stage 2	835	729	-	900	769	-	-	-	-	-	-	-

Approach	EB		WB			NB			SB		
HCM Control Delay, s	9.6		9.7			0.8			0.3		
HCM LOS	A		A								

Minor Lane/Major Mvmt	NBL	NBT	NBR	EBLn1	EBLn2	WBLn1	WBLn2	SBL	SBT	SBR
Capacity (veh/h)	1447	-	-	625	990	581	968	1424	-	-
HCM Lane V/C Ratio	0.014	-	-	0.019	0.016	0.017	0.017	0.005	-	-
HCM Control Delay (s)	7.5	-	-	10.9	8.7	11.3	8.8	7.5	-	-
HCM Lane LOS	A	-	-	B	A	B	A	A	-	-
HCM 95th %tile Q(veh)	0	-	-	0.1	0.1	0.1	0.1	0	-	-

HCM 2010 TWSC
 26: CA 7 & I-8 East Off-ramp/I-8 East On-ramp

01/07/2021

Intersection												
Int Delay, s/veh	3.8											
Movement	EBL	EBT	EBR	WBL	WBT	WBR	NBL	NBT	NBR	SBL	SBT	SBR
Lane Configurations		↔						↑↑	↑		↑	
Traffic Vol, veh/h	128	0	27	0	0	0	0	217	1	1	59	0
Future Vol, veh/h	128	0	27	0	0	0	0	217	1	1	59	0
Conflicting Peds, #/hr	0	0	0	0	0	0	0	0	0	0	0	0
Sign Control	Stop	Stop	Stop	Free	Free	Free	Free	Free	Free	Free	Free	Free
RT Channelized	-	-	None	-	-	None	-	-	None	-	-	None
Storage Length	-	-	-	-	-	-	-	-	0	-	-	-
Veh in Median Storage, #	-	0	-	-	-	-	-	0	-	-	0	-
Grade, %	-	0	-	-	0	-	-	0	-	-	0	-
Peak Hour Factor	92	92	92	92	92	92	92	92	92	92	92	92
Heavy Vehicles, %	2	2	2	2	2	2	2	2	2	2	2	2
Mvmt Flow	139	0	29	0	0	0	0	236	1	1	64	0

Major/Minor	Minor2			Major1			Major2		
Conflicting Flow All	184	303	64	-	0	0	237	0	0
Stage 1	66	66	-	-	-	-	-	-	-
Stage 2	118	237	-	-	-	-	-	-	-
Critical Hdwy	6.63	6.53	6.23	-	-	-	4.13	-	-
Critical Hdwy Stg 1	5.43	5.53	-	-	-	-	-	-	-
Critical Hdwy Stg 2	5.83	5.53	-	-	-	-	-	-	-
Follow-up Hdwy	3.519	4.019	3.319	-	-	-	2.219	-	-
Pot Cap-1 Maneuver	797	609	1000	0	-	-	1329	-	0
Stage 1	956	840	-	0	-	-	-	-	0
Stage 2	895	708	-	0	-	-	-	-	0
Platoon blocked, %									
Mov Cap-1 Maneuver	796	0	1000	-	-	-	1329	-	-
Mov Cap-2 Maneuver	796	0	-	-	-	-	-	-	-
Stage 1	956	0	-	-	-	-	-	-	-
Stage 2	894	0	-	-	-	-	-	-	-

Approach	EB	NB	SB
HCM Control Delay, s	10.5	0	0.1
HCM LOS	B		

Minor Lane/Major Mvmt	NBT	NBR	EBLn1	SBL	SBT
Capacity (veh/h)	-	-	825	1329	-
HCM Lane V/C Ratio	-	-	0.204	0.001	-
HCM Control Delay (s)	-	-	10.5	7.7	-
HCM Lane LOS	-	-	B	A	-
HCM 95th %tile Q(veh)	-	-	0.8	0	-

HCM 2010 TWSC
 26: CA 7 & I-8 East Off-ramp/I-8 East On-ramp

01/11/2021

Intersection												
Int Delay, s/veh	2.8											
Movement	EBL	EBT	EBR	WBL	WBT	WBR	NBL	NBT	NBR	SBL	SBT	SBR
Lane Configurations		↔						↑↑	↑		↑	
Traffic Vol, veh/h	49	0	52	0	0	0	0	160	9	0	78	0
Future Vol, veh/h	49	0	52	0	0	0	0	160	9	0	78	0
Conflicting Peds, #/hr	0	0	0	0	0	0	0	0	0	0	0	0
Sign Control	Stop	Stop	Stop	Free	Free	Free	Free	Free	Free	Free	Free	Free
RT Channelized	-	-	None	-	-	None	-	-	None	-	-	None
Storage Length	-	-	-	-	-	-	-	-	0	-	-	-
Veh in Median Storage, #	-	0	-	-	-	-	-	0	-	-	0	-
Grade, %	-	0	-	-	0	-	-	0	-	-	0	-
Peak Hour Factor	92	92	92	92	92	92	92	92	92	92	92	92
Heavy Vehicles, %	2	2	2	2	2	2	2	2	2	2	2	2
Mvmt Flow	53	0	57	0	0	0	0	174	10	0	85	0

Major/Minor	Minor2			Major1			Major2		
Conflicting Flow All	172	269	85	-	0	0	-	-	0
Stage 1	85	85	-	-	-	-	-	-	-
Stage 2	87	184	-	-	-	-	-	-	-
Critical Hdwy	6.63	6.53	6.23	-	-	-	-	-	-
Critical Hdwy Stg 1	5.43	5.53	-	-	-	-	-	-	-
Critical Hdwy Stg 2	5.83	5.53	-	-	-	-	-	-	-
Follow-up Hdwy	3.519	4.019	3.319	-	-	-	-	-	-
Pot Cap-1 Maneuver	810	637	973	0	-	-	0	-	0
Stage 1	938	824	-	0	-	-	0	-	0
Stage 2	927	747	-	0	-	-	0	-	0
Platoon blocked, %									
Mov Cap-1 Maneuver	810	0	973	-	-	-	-	-	-
Mov Cap-2 Maneuver	810	0	-	-	-	-	-	-	-
Stage 1	938	0	-	-	-	-	-	-	-
Stage 2	927	0	-	-	-	-	-	-	-

Approach	EB	NB	SB
HCM Control Delay, s	9.6	0	0
HCM LOS	A		

Minor Lane/Major Mvmt	NBT	NBR	EBLn1	SBT
Capacity (veh/h)	-	-	886	-
HCM Lane V/C Ratio	-	-	0.124	-
HCM Control Delay (s)	-	-	9.6	-
HCM Lane LOS	-	-	A	-
HCM 95th %tile Q(veh)	-	-	0.4	-

Intersection												
Int Delay, s/veh	1.2											
Movement	EBL	EBT	EBR	WBL	WBT	WBR	NBL	NBT	NBR	SBL	SBT	SBR
Lane Configurations					↕			↕			↑	↗
Traffic Vol, veh/h	0	0	0	4	0	5	23	94	0	0	61	35
Future Vol, veh/h	0	0	0	4	0	5	23	94	0	0	61	35
Conflicting Peds, #/hr	0	0	0	0	0	0	0	0	0	0	0	0
Sign Control	Free	Free	Free	Stop	Stop	Stop	Free	Free	Free	Free	Free	Free
RT Channelized	-	-	None	-	-	None	-	-	None	-	-	None
Storage Length	-	-	-	-	-	-	-	-	-	-	-	0
Veh in Median Storage, #	-	-	-	-	0	-	-	0	-	-	0	-
Grade, %	-	0	-	-	0	-	-	0	-	-	0	-
Peak Hour Factor	92	92	92	92	92	92	92	92	92	92	92	92
Heavy Vehicles, %	2	2	2	2	2	2	2	2	2	2	2	2
Mvmt Flow	0	0	0	4	0	5	25	102	0	0	66	38

Major/Minor	Minor1		Major1		Major2		
Conflicting Flow All	237	256	102	104	0	-	0
Stage 1	152	152	-	-	-	-	-
Stage 2	85	104	-	-	-	-	-
Critical Hdwy	6.42	6.52	6.22	4.12	-	-	-
Critical Hdwy Stg 1	5.42	5.52	-	-	-	-	-
Critical Hdwy Stg 2	5.42	5.52	-	-	-	-	-
Follow-up Hdwy	3.518	4.018	3.318	2.218	-	-	-
Pot Cap-1 Maneuver	751	648	953	1488	-	0	0
Stage 1	876	772	-	-	-	0	0
Stage 2	938	809	-	-	-	0	0
Platoon blocked, %					-	-	-
Mov Cap-1 Maneuver	737	0	953	1488	-	-	-
Mov Cap-2 Maneuver	737	0	-	-	-	-	-
Stage 1	860	0	-	-	-	-	-
Stage 2	938	0	-	-	-	-	-

Approach	WB	NB	SB
HCM Control Delay, s	9.3	1.5	0
HCM LOS	A		

Minor Lane/Major Mvmt	NBL	NBTWBLn1	SBT	SBR
Capacity (veh/h)	1488	-	843	-
HCM Lane V/C Ratio	0.017	-	0.012	-
HCM Control Delay (s)	7.5	0	9.3	-
HCM Lane LOS	A	A	A	-
HCM 95th %tile Q(veh)	0.1	-	0	-

Intersection												
Int Delay, s/veh	0.6											
Movement	EBL	EBT	EBR	WBL	WBT	WBR	NBL	NBT	NBR	SBL	SBT	SBR
Lane Configurations					↕			↕			↑	↗
Traffic Vol, veh/h	0	0	0	6	0	4	14	122	80	0	74	50
Future Vol, veh/h	0	0	0	6	0	4	14	122	80	0	74	50
Conflicting Peds, #/hr	0	0	0	0	0	0	0	0	0	0	0	0
Sign Control	Free	Free	Free	Stop	Stop	Stop	Free	Free	Free	Free	Free	Free
RT Channelized	-	-	None	-	-	None	-	-	None	-	-	None
Storage Length	-	-	-	-	-	-	-	-	-	-	-	0
Veh in Median Storage, #	-	-	-	-	0	-	-	0	-	-	0	-
Grade, %	-	0	-	-	0	-	-	0	-	-	0	-
Peak Hour Factor	92	92	92	92	92	92	92	92	92	92	92	92
Heavy Vehicles, %	2	2	2	2	2	2	2	2	2	2	2	2
Mvmt Flow	0	0	0	7	0	4	15	133	87	0	80	54

Major/Minor	Minor1		Major1		Major2		
Conflicting Flow All	314	341	177	134	0	0	-
Stage 1	207	207	-	-	-	-	-
Stage 2	107	134	-	-	-	-	-
Critical Hdwy	6.42	6.52	6.22	4.12	-	-	-
Critical Hdwy Stg 1	5.42	5.52	-	-	-	-	-
Critical Hdwy Stg 2	5.42	5.52	-	-	-	-	-
Follow-up Hdwy	3.518	4.018	3.318	2.218	-	-	-
Pot Cap-1 Maneuver	679	581	866	1451	-	-	0
Stage 1	828	731	-	-	-	-	0
Stage 2	917	785	-	-	-	-	0
Platoon blocked, %					-	-	-
Mov Cap-1 Maneuver	671	0	866	1451	-	-	-
Mov Cap-2 Maneuver	671	0	-	-	-	-	-
Stage 1	818	0	-	-	-	-	-
Stage 2	917	0	-	-	-	-	-

Approach	WB	NB	SB
HCM Control Delay, s	10	0.5	0
HCM LOS	B		

Minor Lane/Major Mvmt	NBL	NBT	NBRWBLn1	SBT	SBR
Capacity (veh/h)	1451	-	-	737	-
HCM Lane V/C Ratio	0.01	-	-	0.015	-
HCM Control Delay (s)	7.5	0	-	10	-
HCM Lane LOS	A	A	-	B	-
HCM 95th %tile Q(veh)	0	-	-	0	-

APPENDIX D : CONSTRUCTION YEAR PLUS PROJECT ANALYSIS WORKSHEETS

Intersection						
Int Delay, s/veh	0.5					
Movement	EBT	EBR	WBL	WBT	NBL	NBR
Lane Configurations						
Traffic Vol, veh/h	64	225	25	57	0	0
Future Vol, veh/h	64	225	25	57	0	0
Conflicting Peds, #/hr	0	0	0	0	0	0
Sign Control	Free	Free	Free	Free	Stop	Stop
RT Channelized	-	None	-	None	-	None
Storage Length	-	-	-	-	0	-
Veh in Median Storage, #	0	-	-	0	0	-
Grade, %	0	-	-	0	0	-
Peak Hour Factor	92	92	92	92	92	92
Heavy Vehicles, %	2	2	2	2	2	2
Mvmt Flow	70	245	27	62	0	0

Major/Minor	Major1	Major2	Minor1	Minor2	Minor3
Conflicting Flow All	0	0	315	0	309
Stage 1	-	-	-	-	193
Stage 2	-	-	-	-	116
Critical Hdwy	-	-	4.12	-	6.42
Critical Hdwy Stg 1	-	-	-	-	5.42
Critical Hdwy Stg 2	-	-	-	-	5.42
Follow-up Hdwy	-	-	2.218	-	3.518
Pot Cap-1 Maneuver	-	-	1245	-	683
Stage 1	-	-	-	-	840
Stage 2	-	-	-	-	909
Platoon blocked, %	-	-	-	-	-
Mov Cap-1 Maneuver	-	-	1245	-	668
Mov Cap-2 Maneuver	-	-	-	-	668
Stage 1	-	-	-	-	840
Stage 2	-	-	-	-	889

Approach	EB	WB	NB
HCM Control Delay, s	0	2.4	0
HCM LOS			A

Minor Lane/Major Mvmt	NBLn1	EBT	EBR	WBL	WBT
Capacity (veh/h)	-	-	-	1245	-
HCM Lane V/C Ratio	-	-	-	0.022	-
HCM Control Delay (s)	0	-	-	8	0
HCM Lane LOS	A	-	-	A	A
HCM 95th %tile Q(veh)	-	-	-	0.1	-

Intersection						
Int Delay, s/veh	7					
Movement	EBT	EBR	WBL	WBT	NBL	NBR
Lane Configurations						
Traffic Vol, veh/h	70	0	0	87	225	25
Future Vol, veh/h	70	0	0	87	225	25
Conflicting Peds, #/hr	0	0	0	0	0	0
Sign Control	Free	Free	Free	Free	Stop	Stop
RT Channelized	-	None	-	None	-	None
Storage Length	-	-	-	-	0	-
Veh in Median Storage, #	0	-	-	0	0	-
Grade, %	0	-	-	0	0	-
Peak Hour Factor	92	92	92	92	92	92
Heavy Vehicles, %	2	2	2	2	2	2
Mvmt Flow	76	0	0	95	245	27

Major/Minor	Major1	Major2	Minor1	Minor2	Minor3
Conflicting Flow All	0	0	76	0	171
Stage 1	-	-	-	-	76
Stage 2	-	-	-	-	95
Critical Hdwy	-	-	4.12	-	6.42
Critical Hdwy Stg 1	-	-	-	-	5.42
Critical Hdwy Stg 2	-	-	-	-	5.42
Follow-up Hdwy	-	-	2.218	-	3.518
Pot Cap-1 Maneuver	-	-	1523	-	819
Stage 1	-	-	-	-	947
Stage 2	-	-	-	-	929
Platoon blocked, %	-	-	-	-	-
Mov Cap-1 Maneuver	-	-	1523	-	819
Mov Cap-2 Maneuver	-	-	-	-	819
Stage 1	-	-	-	-	947
Stage 2	-	-	-	-	929

Approach	EB	WB	NB
HCM Control Delay, s	0	0	11.4
HCM LOS			B

Minor Lane/Major Mvmt	NBLn1	EBT	EBR	WBL	WBT
Capacity (veh/h)	833	-	-	1523	-
HCM Lane V/C Ratio	0.326	-	-	-	-
HCM Control Delay (s)	11.4	-	-	0	-
HCM Lane LOS	B	-	-	A	-
HCM 95th %tile Q(veh)	1.4	-	-	0	-

Intersection						
Int Delay, s/veh	0.6					
Movement	EBL	EBT	WBT	WBR	SBL	SBR
Lane Configurations	↶	↷	↶		↶	↷
Traffic Vol, veh/h	11	289	57	7	6	7
Future Vol, veh/h	11	289	57	7	6	7
Conflicting Peds, #/hr	0	0	0	0	0	0
Sign Control	Free	Free	Free	Free	Stop	Stop
RT Channelized	-	None	-	None	-	None
Storage Length	0	-	-	-	0	0
Veh in Median Storage, #	-	0	0	-	0	-
Grade, %	-	0	0	-	0	-
Peak Hour Factor	92	92	92	92	92	92
Heavy Vehicles, %	2	2	2	2	2	2
Mvmt Flow	12	314	62	8	7	8

Major/Minor	Major1	Major2	Minor2		
Conflicting Flow All	70	0	-	0	404 66
Stage 1	-	-	-	-	66 -
Stage 2	-	-	-	-	338 -
Critical Hdwy	4.12	-	-	-	6.42 6.22
Critical Hdwy Stg 1	-	-	-	-	5.42 -
Critical Hdwy Stg 2	-	-	-	-	5.42 -
Follow-up Hdwy	2.218	-	-	-	3.518 3.318
Pot Cap-1 Maneuver	1531	-	-	-	603 998
Stage 1	-	-	-	-	957 -
Stage 2	-	-	-	-	722 -
Platoon blocked, %		-	-	-	
Mov Cap-1 Maneuver	1531	-	-	-	598 998
Mov Cap-2 Maneuver	-	-	-	-	598 -
Stage 1	-	-	-	-	949 -
Stage 2	-	-	-	-	722 -

Approach	EB	WB	SB
HCM Control Delay, s	0.3	0	9.8
HCM LOS			A

Minor Lane/Major Mvmt	EBL	EBT	WBT	WBR	SBLn1	SBLn2
Capacity (veh/h)	1531	-	-	-	598	998
HCM Lane V/C Ratio	0.008	-	-	-	0.011	0.008
HCM Control Delay (s)	7.4	-	-	-	11.1	8.6
HCM Lane LOS	A	-	-	-	B	A
HCM 95th %tile Q(veh)	0	-	-	-	0	0

Intersection						
Int Delay, s/veh	0.6					
Movement	EBL	EBT	WBT	WBR	SBL	SBR
Lane Configurations	↙	↑	↘		↙	↘
Traffic Vol, veh/h	5	70	312	11	2	18
Future Vol, veh/h	5	70	312	11	2	18
Conflicting Peds, #/hr	0	0	0	0	0	0
Sign Control	Free	Free	Free	Free	Stop	Stop
RT Channelized	-	None	-	None	-	None
Storage Length	0	-	-	-	0	0
Veh in Median Storage, #	-	0	0	-	0	-
Grade, %	-	0	0	-	0	-
Peak Hour Factor	92	92	92	92	92	92
Heavy Vehicles, %	2	2	2	2	2	2
Mvmt Flow	5	76	339	12	2	20

























Major/Minor	Major1	Major2	Minor2		
Conflicting Flow All	351	0	-	0	431 345
Stage 1	-	-	-	-	345 -
Stage 2	-	-	-	-	86 -
Critical Hdwy	4.12	-	-	-	6.42 6.22
Critical Hdwy Stg 1	-	-	-	-	5.42 -
Critical Hdwy Stg 2	-	-	-	-	5.42 -
Follow-up Hdwy	2.218	-	-	-	3.518 3.318
Pot Cap-1 Maneuver	1208	-	-	-	581 698
Stage 1	-	-	-	-	717 -
Stage 2	-	-	-	-	937 -
Platoon blocked, %		-	-	-	
Mov Cap-1 Maneuver	1208	-	-	-	579 698
Mov Cap-2 Maneuver	-	-	-	-	579 -
Stage 1	-	-	-	-	714 -
Stage 2	-	-	-	-	937 -

Approach	EB	WB	SB
HCM Control Delay, s	0.5	0	10.4
HCM LOS			B

Minor Lane/Major Mvmt	EBL	EBT	WBT	WBR	SBLn1	SBLn2
Capacity (veh/h)	1208	-	-	-	579	698
HCM Lane V/C Ratio	0.004	-	-	-	0.004	0.028
HCM Control Delay (s)	8	-	-	-	11.2	10.3
HCM Lane LOS	A	-	-	-	B	B
HCM 95th %tile Q(veh)	0	-	-	-	0	0.1

HCM 2010 Signalized Intersection Capacity Analysis
12: CA 7 & CA 98

01/11/2021

												
Movement	EBL	EBT	EBR	WBL	WBT	WBR	NBL	NBT	NBR	SBL	SBT	SBR
Lane Configurations												
Traffic Volume (veh/h)	22	26	112	28	27	8	56	186	33	169	130	42
Future Volume (veh/h)	22	26	112	28	27	8	56	186	33	169	130	42
Number	7	4	14	3	8	18	5	2	12	1	6	16
Initial Q, veh	0	0	0	0	0	0	0	0	0	0	0	0
Ped-Bike Adj (A_pbT)	1.00		1.00	1.00		1.00	1.00		1.00	1.00		1.00
Parking Bus Adj	1.00	1.00	1.00	1.00	1.00	1.00	1.00	1.00	1.00	1.00	1.00	1.00
Adj Sat Flow, veh/h/ln	1863	1863	1863	1863	1863	1863	1863	1863	1863	1863	1863	1863
Adj Flow Rate, veh/h	24	28	122	30	29	9	61	202	36	184	141	46
Adj No. of Lanes	1	1	2	1	1	1	2	2	1	1	2	1
Peak Hour Factor	0.92	0.92	0.92	0.92	0.92	0.92	0.92	0.92	0.92	0.92	0.92	0.92
Percent Heavy Veh, %	2	2	2	2	2	2	2	2	2	2	2	2
Opposing Right Turn Influence	Yes			Yes			Yes			Yes		
Cap, veh/h	693	745	1115	642	745	633	1187	1416	633	574	1416	633
HCM Platoon Ratio	1.00	1.00	1.00	1.00	1.00	1.00	1.00	1.00	1.00	1.00	1.00	1.00
Prop Arrive On Green	0.40	0.40	0.40	0.40	0.40	0.40	0.40	0.40	0.40	0.40	0.40	0.40
Ln Grp Delay, s/veh	8.6	8.3	8.7	8.7	8.3	8.2	9.1	8.8	8.5	12.3	8.6	8.6
Ln Grp LOS	A	A	A	A	A	A	A	A	A	B	A	A
Approach Vol, veh/h		174			68			299			371	
Approach Delay, s/veh		8.6			8.5			8.8			10.4	
Approach LOS		A			A			A			B	
Timer:		1	2	3	4	5	6	7	8			
Assigned Phs			2		4		6		8			
Case No			5.0		5.0		5.0		5.0			
Phs Duration (G+Y+Rc), s			22.5		22.5		22.5		22.5			
Change Period (Y+Rc), s			4.5		4.5		4.5		4.5			
Max Green (Gmax), s			18.0		18.0		18.0		18.0			
Max Allow Headway (MAH), s			4.9		4.2		4.7		4.6			
Max Q Clear (g_c+I1), s			3.9		3.2		9.2		3.1			
Green Ext Time (g_e), s			1.3		0.5		1.2		0.2			
Prob of Phs Call (p_c)			1.00		1.00		1.00		1.00			
Prob of Max Out (p_x)			0.00		0.00		0.00		0.00			
Left-Turn Movement Data												
Assigned Mvmt			5		7		1		3			
Mvmt Sat Flow, veh/h			2312		1364		1138		1232			
Through Movement Data												
Assigned Mvmt			2		4		6		8			
Mvmt Sat Flow, veh/h			3539		1863		3539		1863			
Right-Turn Movement Data												
Assigned Mvmt			12		14		16		18			
Mvmt Sat Flow, veh/h			1583		2787		1583		1583			
Left Lane Group Data												
Assigned Mvmt		0	5	0	7	0	1	0	3			
Lane Assignment												

HCM 2010 Signalized Intersection Capacity Analysis
 12: CA 7 & CA 98

01/11/2021

Lanes in Grp	0	2	0	1	0	1	0	1
Grp Vol (v), veh/h	0	61	0	24	0	184	0	30
Grp Sat Flow (s), veh/h/ln	0	1156	0	1364	0	1138	0	1232
Q Serve Time (g_s), s	0.0	0.8	0.0	0.5	0.0	5.5	0.0	0.7
Cycle Q Clear Time (g_c), s	0.0	1.9	0.0	0.9	0.0	7.2	0.0	1.1
Perm LT Sat Flow (s_l), veh/h/ln	0	1156	0	1364	0	1138	0	1232
Shared LT Sat Flow (s_sh), veh/h/ln	0	0	0	0	0	0	0	0
Perm LT Eff Green (g_p), s	0.0	18.0	0.0	18.0	0.0	18.0	0.0	18.0
Perm LT Serve Time (g_u), s	0.0	16.9	0.0	17.6	0.0	16.4	0.0	17.6
Perm LT Q Serve Time (g_ps), s	0.0	0.8	0.0	0.5	0.0	5.5	0.0	0.7
Time to First Blk (g_f), s	0.0	0.0	0.0	0.0	0.0	0.0	0.0	0.0
Serve Time pre Blk (g_fs), s	0.0	0.0	0.0	0.0	0.0	0.0	0.0	0.0
Prop LT Inside Lane (P_L)	0.00	1.00	0.00	1.00	0.00	1.00	0.00	1.00
Lane Grp Cap (c), veh/h	0	1187	0	693	0	574	0	642
V/C Ratio (X)	0.00	0.05	0.00	0.03	0.00	0.32	0.00	0.05
Avail Cap (c_a), veh/h	0	1187	0	693	0	574	0	642
Upstream Filter (I)	0.00	1.00	0.00	1.00	0.00	1.00	0.00	1.00
Uniform Delay (d1), s/veh	0.0	9.0	0.0	8.5	0.0	10.9	0.0	8.6
Incr Delay (d2), s/veh	0.0	0.1	0.0	0.1	0.0	1.5	0.0	0.1
Initial Q Delay (d3), s/veh	0.0	0.0	0.0	0.0	0.0	0.0	0.0	0.0
Control Delay (d), s/veh	0.0	9.1	0.0	8.6	0.0	12.3	0.0	8.7
1st-Term Q (Q1), veh/ln	0.0	0.2	0.0	0.2	0.0	1.7	0.0	0.2
2nd-Term Q (Q2), veh/ln	0.0	0.0	0.0	0.0	0.0	0.2	0.0	0.0
3rd-Term Q (Q3), veh/ln	0.0	0.0	0.0	0.0	0.0	0.0	0.0	0.0
%ile Back of Q Factor (f_B%)	0.00	1.00	0.00	1.00	0.00	1.00	0.00	1.00
%ile Back of Q (50%), veh/ln	0.0	0.3	0.0	0.2	0.0	2.0	0.0	0.3
%ile Storage Ratio (RQ%)	0.00	0.00	0.00	0.00	0.00	0.08	0.00	0.00
Initial Q (Qb), veh	0.0	0.0	0.0	0.0	0.0	0.0	0.0	0.0
Final (Residual) Q (Qe), veh	0.0	0.0	0.0	0.0	0.0	0.0	0.0	0.0
Sat Delay (ds), s/veh	0.0	0.0	0.0	0.0	0.0	0.0	0.0	0.0
Sat Q (Qs), veh	0.0	0.0	0.0	0.0	0.0	0.0	0.0	0.0
Sat Cap (cs), veh/h	0	0	0	0	0	0	0	0
Initial Q Clear Time (tc), h	0.0	0.0	0.0	0.0	0.0	0.0	0.0	0.0
Middle Lane Group Data								
Assigned Mvmt	0	2	0	4	0	6	0	8
Lane Assignment		T		T		T		T
Lanes in Grp	0	2	0	1	0	2	0	1
Grp Vol (v), veh/h	0	202	0	28	0	141	0	29
Grp Sat Flow (s), veh/h/ln	0	1770	0	1863	0	1770	0	1863
Q Serve Time (g_s), s	0.0	1.6	0.0	0.4	0.0	1.1	0.0	0.4
Cycle Q Clear Time (g_c), s	0.0	1.6	0.0	0.4	0.0	1.1	0.0	0.4
Lane Grp Cap (c), veh/h	0	1416	0	745	0	1416	0	745
V/C Ratio (X)	0.00	0.14	0.00	0.04	0.00	0.10	0.00	0.04
Avail Cap (c_a), veh/h	0	1416	0	745	0	1416	0	745
Upstream Filter (I)	0.00	1.00	0.00	1.00	0.00	1.00	0.00	1.00
Uniform Delay (d1), s/veh	0.0	8.6	0.0	8.2	0.0	8.4	0.0	8.2
Incr Delay (d2), s/veh	0.0	0.2	0.0	0.1	0.0	0.1	0.0	0.1
Initial Q Delay (d3), s/veh	0.0	0.0	0.0	0.0	0.0	0.0	0.0	0.0
Control Delay (d), s/veh	0.0	8.8	0.0	8.3	0.0	8.6	0.0	8.3
1st-Term Q (Q1), veh/ln	0.0	0.8	0.0	0.2	0.0	0.5	0.0	0.2

Baseline

Synchro 10 Report
 Page 2

PC ORIGINAL PKG

HCM 2010 Signalized Intersection Capacity Analysis
 12: CA 7 & CA 98

01/11/2021

2nd-Term Q (Q2), veh/ln	0.0	0.0	0.0	0.0	0.0	0.0	0.0	0.0
3rd-Term Q (Q3), veh/ln	0.0	0.0	0.0	0.0	0.0	0.0	0.0	0.0
%ile Back of Q Factor (f_B%)	0.00	1.00	0.00	1.00	0.00	1.00	0.00	1.00
%ile Back of Q (50%), veh/ln	0.0	0.8	0.0	0.2	0.0	0.6	0.0	0.2
%ile Storage Ratio (RQ%)	0.00	0.01	0.00	0.00	0.00	0.02	0.00	0.00
Initial Q (Qb), veh	0.0	0.0	0.0	0.0	0.0	0.0	0.0	0.0
Final (Residual) Q (Qe), veh	0.0	0.0	0.0	0.0	0.0	0.0	0.0	0.0
Sat Delay (ds), s/veh	0.0	0.0	0.0	0.0	0.0	0.0	0.0	0.0
Sat Q (Qs), veh	0.0	0.0	0.0	0.0	0.0	0.0	0.0	0.0
Sat Cap (cs), veh/h	0	0	0	0	0	0	0	0
Initial Q Clear Time (tc), h	0.0	0.0	0.0	0.0	0.0	0.0	0.0	0.0

Right Lane Group Data

























Assigned Mvmt	0	12	0	14	0	16	0	18
Lane Assignment		R		R		R		R
Lanes in Grp	0	1	0	2	0	1	0	1
Grp Vol (v), veh/h	0	36	0	122	0	46	0	9
Grp Sat Flow (s), veh/h/ln	0	1583	0	1393	0	1583	0	1583
Q Serve Time (g_s), s	0.0	0.6	0.0	1.2	0.0	0.8	0.0	0.2
Cycle Q Clear Time (g_c), s	0.0	0.6	0.0	1.2	0.0	0.8	0.0	0.2
Prot RT Sat Flow (s_R), veh/h/ln	0.0	0.0	0.0	0.0	0.0	0.0	0.0	0.0
Prot RT Eff Green (g_R), s	0.0	0.0	0.0	0.0	0.0	0.0	0.0	0.0
Prop RT Outside Lane (P_R)	0.00	1.00	0.00	1.00	0.00	1.00	0.00	1.00
Lane Grp Cap (c), veh/h	0	633	0	1115	0	633	0	633
V/C Ratio (X)	0.00	0.06	0.00	0.11	0.00	0.07	0.00	0.01
Avail Cap (c_a), veh/h	0	633	0	1115	0	633	0	633
Upstream Filter (I)	0.00	1.00	0.00	1.00	0.00	1.00	0.00	1.00
Uniform Delay (d1), s/veh	0.0	8.3	0.0	8.5	0.0	8.3	0.0	8.1
Incr Delay (d2), s/veh	0.0	0.2	0.0	0.2	0.0	0.2	0.0	0.0
Initial Q Delay (d3), s/veh	0.0	0.0	0.0	0.0	0.0	0.0	0.0	0.0
Control Delay (d), s/veh	0.0	8.5	0.0	8.7	0.0	8.6	0.0	8.2
1st-Term Q (Q1), veh/ln	0.0	0.3	0.0	0.5	0.0	0.3	0.0	0.1
2nd-Term Q (Q2), veh/ln	0.0	0.0	0.0	0.0	0.0	0.0	0.0	0.0
3rd-Term Q (Q3), veh/ln	0.0	0.0	0.0	0.0	0.0	0.0	0.0	0.0
%ile Back of Q Factor (f_B%)	0.00	1.00	0.00	1.00	0.00	1.00	0.00	1.00
%ile Back of Q (50%), veh/ln	0.0	0.3	0.0	0.5	0.0	0.4	0.0	0.1
%ile Storage Ratio (RQ%)	0.00	0.00	0.00	0.00	0.00	0.02	0.00	0.00
Initial Q (Qb), veh	0.0	0.0	0.0	0.0	0.0	0.0	0.0	0.0
Final (Residual) Q (Qe), veh	0.0	0.0	0.0	0.0	0.0	0.0	0.0	0.0
Sat Delay (ds), s/veh	0.0	0.0	0.0	0.0	0.0	0.0	0.0	0.0
Sat Q (Qs), veh	0.0	0.0	0.0	0.0	0.0	0.0	0.0	0.0
Sat Cap (cs), veh/h	0	0	0	0	0	0	0	0
Initial Q Clear Time (tc), h	0.0	0.0	0.0	0.0	0.0	0.0	0.0	0.0

Intersection Summary

HCM 2010 Ctrl Delay	9.4
HCM 2010 LOS	A

HCM 2010 Signalized Intersection Capacity Analysis
 12: CA 7 & CA 98

12/15/2021

												
Movement	EBL	EBT	EBR	WBL	WBT	WBR	NBL	NBT	NBR	SBL	SBT	SBR
Lane Configurations												
Traffic Volume (veh/h)	38	55	103	15	169	9	99	112	18	0	68	65
Future Volume (veh/h)	38	55	103	15	169	9	99	112	18	0	68	65
Number	7	4	14	3	8	18	5	2	12	1	6	16
Initial Q, veh	0	0	0	0	0	0	0	0	0	0	0	0
Ped-Bike Adj (A_pbT)	1.00		1.00	1.00		1.00	1.00		1.00	1.00		1.00
Parking Bus Adj	1.00	1.00	1.00	1.00	1.00	1.00	1.00	1.00	1.00	1.00	1.00	1.00
Adj Sat Flow, veh/h/ln	1863	1863	1863	1863	1863	1863	1863	1863	1863	1863	1863	1863
Adj Flow Rate, veh/h	41	60	112	16	184	10	108	122	20	0	74	71
Adj No. of Lanes	1	1	2	1	1	1	2	2	1	1	2	1
Peak Hour Factor	0.92	0.92	0.92	0.92	0.92	0.92	0.92	0.92	0.92	0.92	0.92	0.92
Percent Heavy Veh, %	2	2	2	2	2	2	2	2	2	2	2	2
Opposing Right Turn Influence	Yes			Yes			Yes			Yes		
Cap, veh/h	556	745	1115	619	745	633	1250	1416	633	160	1416	633
HCM Platoon Ratio	1.00	1.00	1.00	1.00	1.00	1.00	1.00	1.00	1.00	1.00	1.00	1.00
Prop Arrive On Green	0.40	0.40	0.40	0.40	0.40	0.40	0.40	0.40	0.40	0.00	0.40	0.40
Ln Grp Delay, s/veh	10.6	8.6	8.6	8.8	9.8	8.2	9.0	8.5	8.3	0.0	8.3	8.8
Ln Grp LOS	B	A	A	A	A	A	A	A	A		A	A
Approach Vol, veh/h		213			210			250			145	
Approach Delay, s/veh		9.0			9.6			8.7			8.6	
Approach LOS		A			A			A			A	
Timer:		1	2	3	4	5	6	7	8			
Assigned Phs			2		4		6		8			
Case No			5.0		5.0		5.0		5.0			
Phs Duration (G+Y+Rc), s			22.5		22.5		22.5		22.5			
Change Period (Y+Rc), s			4.5		4.5		4.5		4.5			
Max Green (Gmax), s			18.0		18.0		18.0		18.0			
Max Allow Headway (MAH), s			4.7		4.4		4.7		5.1			
Max Q Clear (g_c+I1), s			3.9		6.0		3.3		5.0			
Green Ext Time (g_e), s			1.0		0.6		0.5		0.8			
Prob of Phs Call (p_c)			1.00		1.00		1.00		1.00			
Prob of Max Out (p_x)			0.00		0.00		0.00		0.00			
Left-Turn Movement Data												
Assigned Mvmt			5		7		1		3			
Mvmt Sat Flow, veh/h			2402		1184		1241		1208			
Through Movement Data												
Assigned Mvmt			2		4		6		8			
Mvmt Sat Flow, veh/h			3539		1863		3539		1863			
Right-Turn Movement Data												
Assigned Mvmt			12		14		16		18			
Mvmt Sat Flow, veh/h			1583		2787		1583		1583			
Left Lane Group Data												
Assigned Mvmt		0	5	0	7	0	1	0	3			
Lane Assignment												

HCM 2010 Signalized Intersection Capacity Analysis
 12: CA 7 & CA 98

12/15/2021

Lanes in Grp	0	2	0	1	0	1	0	1
Grp Vol (v), veh/h	0	108	0	41	0	0	0	16
Grp Sat Flow (s), veh/h/ln	0	1201	0	1184	0	1241	0	1208
Q Serve Time (g_s), s	0.0	1.3	0.0	1.1	0.0	0.0	0.0	0.4
Cycle Q Clear Time (g_c), s	0.0	1.9	0.0	4.0	0.0	0.0	0.0	1.3
Perm LT Sat Flow (s_l), veh/h/ln	0	1201	0	1184	0	1241	0	1208
Shared LT Sat Flow (s_sh), veh/h/ln	0	0	0	0	0	0	0	0
Perm LT Eff Green (g_p), s	0.0	18.0	0.0	18.0	0.0	0.0	0.0	18.0
Perm LT Serve Time (g_u), s	0.0	17.4	0.0	15.0	0.0	0.0	0.0	17.1
Perm LT Q Serve Time (g_ps), s	0.0	1.3	0.0	1.1	0.0	0.0	0.0	0.4
Time to First Blk (g_f), s	0.0	0.0	0.0	0.0	0.0	0.0	0.0	0.0
Serve Time pre Blk (g_fs), s	0.0	0.0	0.0	0.0	0.0	0.0	0.0	0.0
Prop LT Inside Lane (P_L)	0.00	1.00	0.00	1.00	0.00	1.00	0.00	1.00
Lane Grp Cap (c), veh/h	0	1250	0	556	0	160	0	619
V/C Ratio (X)	0.00	0.09	0.00	0.07	0.00	0.00	0.00	0.03
Avail Cap (c_a), veh/h	0	1250	0	556	0	160	0	619
Upstream Filter (I)	0.00	1.00	0.00	1.00	0.00	0.00	0.00	1.00
Uniform Delay (d1), s/veh	0.0	8.8	0.0	10.3	0.0	0.0	0.0	8.8
Incr Delay (d2), s/veh	0.0	0.1	0.0	0.3	0.0	0.0	0.0	0.1
Initial Q Delay (d3), s/veh	0.0	0.0	0.0	0.0	0.0	0.0	0.0	0.0
Control Delay (d), s/veh	0.0	9.0	0.0	10.6	0.0	0.0	0.0	8.8
1st-Term Q (Q1), veh/ln	0.0	0.4	0.0	0.4	0.0	0.0	0.0	0.1
2nd-Term Q (Q2), veh/ln	0.0	0.0	0.0	0.0	0.0	0.0	0.0	0.0
3rd-Term Q (Q3), veh/ln	0.0	0.0	0.0	0.0	0.0	0.0	0.0	0.0
%ile Back of Q Factor (f_B%)	0.00	1.00	0.00	1.00	0.00	1.00	0.00	1.00
%ile Back of Q (50%), veh/ln	0.0	0.4	0.0	0.4	0.0	0.0	0.0	0.1
%ile Storage Ratio (RQ%)	0.00	0.01	0.00	0.00	0.00	0.00	0.00	0.00
Initial Q (Qb), veh	0.0	0.0	0.0	0.0	0.0	0.0	0.0	0.0
Final (Residual) Q (Qe), veh	0.0	0.0	0.0	0.0	0.0	0.0	0.0	0.0
Sat Delay (ds), s/veh	0.0	0.0	0.0	0.0	0.0	0.0	0.0	0.0
Sat Q (Qs), veh	0.0	0.0	0.0	0.0	0.0	0.0	0.0	0.0
Sat Cap (cs), veh/h	0	0	0	0	0	0	0	0
Initial Q Clear Time (tc), h	0.0	0.0	0.0	0.0	0.0	0.0	0.0	0.0
Middle Lane Group Data								
Assigned Mvmt	0	2	0	4	0	6	0	8
Lane Assignment		T		T		T		T
Lanes in Grp	0	2	0	1	0	2	0	1
Grp Vol (v), veh/h	0	122	0	60	0	74	0	184
Grp Sat Flow (s), veh/h/ln	0	1770	0	1863	0	1770	0	1863
Q Serve Time (g_s), s	0.0	1.0	0.0	0.9	0.0	0.6	0.0	3.0
Cycle Q Clear Time (g_c), s	0.0	1.0	0.0	0.9	0.0	0.6	0.0	3.0
Lane Grp Cap (c), veh/h	0	1416	0	745	0	1416	0	745
V/C Ratio (X)	0.00	0.09	0.00	0.08	0.00	0.05	0.00	0.25
Avail Cap (c_a), veh/h	0	1416	0	745	0	1416	0	745
Upstream Filter (I)	0.00	1.00	0.00	1.00	0.00	1.00	0.00	1.00
Uniform Delay (d1), s/veh	0.0	8.4	0.0	8.4	0.0	8.3	0.0	9.0
Incr Delay (d2), s/veh	0.0	0.1	0.0	0.2	0.0	0.1	0.0	0.8
Initial Q Delay (d3), s/veh	0.0	0.0	0.0	0.0	0.0	0.0	0.0	0.0
Control Delay (d), s/veh	0.0	8.5	0.0	8.6	0.0	8.3	0.0	9.8
1st-Term Q (Q1), veh/ln	0.0	0.5	0.0	0.4	0.0	0.3	0.0	1.5

Baseline

Synchro 10 Report
 Page 2

PC ORIGINAL PKG

HCM 2010 Signalized Intersection Capacity Analysis
 12: CA 7 & CA 98

12/15/2021

2nd-Term Q (Q2), veh/ln	0.0	0.0	0.0	0.0	0.0	0.0	0.0	0.2
3rd-Term Q (Q3), veh/ln	0.0	0.0	0.0	0.0	0.0	0.0	0.0	0.0
%ile Back of Q Factor (f_B%)	0.00	1.00	0.00	1.00	0.00	1.00	0.00	1.00
%ile Back of Q (50%), veh/ln	0.0	0.5	0.0	0.5	0.0	0.3	0.0	1.6
%ile Storage Ratio (RQ%)	0.00	0.01	0.00	0.00	0.00	0.01	0.00	0.00
Initial Q (Qb), veh	0.0	0.0	0.0	0.0	0.0	0.0	0.0	0.0
Final (Residual) Q (Qe), veh	0.0	0.0	0.0	0.0	0.0	0.0	0.0	0.0
Sat Delay (ds), s/veh	0.0	0.0	0.0	0.0	0.0	0.0	0.0	0.0
Sat Q (Qs), veh	0.0	0.0	0.0	0.0	0.0	0.0	0.0	0.0
Sat Cap (cs), veh/h	0	0	0	0	0	0	0	0
Initial Q Clear Time (tc), h	0.0	0.0	0.0	0.0	0.0	0.0	0.0	0.0

Right Lane Group Data

Assigned Mvmt	0	12	0	14	0	16	0	18
Lane Assignment		R		R		R		R
Lanes in Grp	0	1	0	2	0	1	0	1
Grp Vol (v), veh/h	0	20	0	112	0	71	0	10
Grp Sat Flow (s), veh/h/ln	0	1583	0	1393	0	1583	0	1583
Q Serve Time (g_s), s	0.0	0.3	0.0	1.1	0.0	1.3	0.0	0.2
Cycle Q Clear Time (g_c), s	0.0	0.3	0.0	1.1	0.0	1.3	0.0	0.2
Prot RT Sat Flow (s_R), veh/h/ln	0.0	0.0	0.0	0.0	0.0	0.0	0.0	0.0
Prot RT Eff Green (g_R), s	0.0	0.0	0.0	0.0	0.0	0.0	0.0	0.0
Prop RT Outside Lane (P_R)	0.00	1.00	0.00	1.00	0.00	1.00	0.00	1.00
Lane Grp Cap (c), veh/h	0	633	0	1115	0	633	0	633
V/C Ratio (X)	0.00	0.03	0.00	0.10	0.00	0.11	0.00	0.02
Avail Cap (c_a), veh/h	0	633	0	1115	0	633	0	633
Upstream Filter (I)	0.00	1.00	0.00	1.00	0.00	1.00	0.00	1.00
Uniform Delay (d1), s/veh	0.0	8.2	0.0	8.4	0.0	8.5	0.0	8.2
Incr Delay (d2), s/veh	0.0	0.1	0.0	0.2	0.0	0.4	0.0	0.0
Initial Q Delay (d3), s/veh	0.0	0.0	0.0	0.0	0.0	0.0	0.0	0.0
Control Delay (d), s/veh	0.0	8.3	0.0	8.6	0.0	8.8	0.0	8.2
1st-Term Q (Q1), veh/ln	0.0	0.1	0.0	0.4	0.0	0.6	0.0	0.1
2nd-Term Q (Q2), veh/ln	0.0	0.0	0.0	0.0	0.0	0.1	0.0	0.0
3rd-Term Q (Q3), veh/ln	0.0	0.0	0.0	0.0	0.0	0.0	0.0	0.0
%ile Back of Q Factor (f_B%)	0.00	1.00	0.00	1.00	0.00	1.00	0.00	1.00
%ile Back of Q (50%), veh/ln	0.0	0.2	0.0	0.5	0.0	0.6	0.0	0.1
%ile Storage Ratio (RQ%)	0.00	0.00	0.00	0.00	0.00	0.03	0.00	0.00
Initial Q (Qb), veh	0.0	0.0	0.0	0.0	0.0	0.0	0.0	0.0
Final (Residual) Q (Qe), veh	0.0	0.0	0.0	0.0	0.0	0.0	0.0	0.0
Sat Delay (ds), s/veh	0.0	0.0	0.0	0.0	0.0	0.0	0.0	0.0
Sat Q (Qs), veh	0.0	0.0	0.0	0.0	0.0	0.0	0.0	0.0
Sat Cap (cs), veh/h	0	0	0	0	0	0	0	0
Initial Q Clear Time (tc), h	0.0	0.0	0.0	0.0	0.0	0.0	0.0	0.0

Intersection Summary

HCM 2010 Ctrl Delay	9.0
HCM 2010 LOS	A

Intersection												
Int Delay, s/veh	0.9											
Movement	EBL	EBT	EBR	WBL	WBT	WBR	NBL	NBT	NBR	SBL	SBT	SBR
Lane Configurations		↕	↗		↕	↗	↖	↖	↖	↖	↖	↖
Traffic Vol, veh/h	0	3	13	3	2	14	16	207	3	8	324	11
Future Vol, veh/h	0	3	13	3	2	14	16	207	3	8	324	11
Conflicting Peds, #/hr	0	0	0	0	0	0	0	0	0	0	0	0
Sign Control	Stop	Stop	Stop	Stop	Stop	Stop	Free	Free	Free	Free	Free	Free
RT Channelized	-	-	None	-	-	None	-	-	None	-	-	None
Storage Length	-	-	0	-	-	0	0	-	0	0	-	0
Veh in Median Storage, #	-	0	-	-	0	-	-	0	-	-	0	-
Grade, %	-	0	-	-	0	-	-	0	-	-	0	-
Peak Hour Factor	92	92	92	92	92	92	92	92	92	92	92	92
Heavy Vehicles, %	2	2	2	2	2	2	2	2	2	2	2	2
Mvmt Flow	0	3	14	3	2	15	17	225	3	9	352	12

Major/Minor	Minor2		Minor1		Major1			Major2				
Conflicting Flow All	518	632	176	455	641	113	364	0	0	228	0	0
Stage 1	370	370	-	259	259	-	-	-	-	-	-	-
Stage 2	148	262	-	196	382	-	-	-	-	-	-	-
Critical Hdwy	7.54	6.54	6.94	7.54	6.54	6.94	4.14	-	-	4.14	-	-
Critical Hdwy Stg 1	6.54	5.54	-	6.54	5.54	-	-	-	-	-	-	-
Critical Hdwy Stg 2	6.54	5.54	-	6.54	5.54	-	-	-	-	-	-	-
Follow-up Hdwy	3.52	4.02	3.32	3.52	4.02	3.32	2.22	-	-	2.22	-	-
Pot Cap-1 Maneuver	440	396	837	489	391	918	1191	-	-	1337	-	-
Stage 1	622	619	-	723	692	-	-	-	-	-	-	-
Stage 2	840	690	-	787	611	-	-	-	-	-	-	-
Platoon blocked, %								-	-	-	-	-
Mov Cap-1 Maneuver	424	388	837	470	383	918	1191	-	-	1337	-	-
Mov Cap-2 Maneuver	424	388	-	470	383	-	-	-	-	-	-	-
Stage 1	613	615	-	713	682	-	-	-	-	-	-	-
Stage 2	812	680	-	764	607	-	-	-	-	-	-	-

Approach	EB		WB		NB			SB		
HCM Control Delay, s	10.3		10.2		0.6			0.2		
HCM LOS	B		B							

Minor Lane/Major Mvmt	NBL	NBT	NBR	EBLn1	EBLn2	WBLn1	WBLn2	SBL	SBT	SBR
Capacity (veh/h)	1191	-	-	388	837	431	918	1337	-	-
HCM Lane V/C Ratio	0.015	-	-	0.008	0.017	0.013	0.017	0.007	-	-
HCM Control Delay (s)	8.1	-	-	14.4	9.4	13.5	9	7.7	-	-
HCM Lane LOS	A	-	-	B	A	B	A	A	-	-
HCM 95th %tile Q(veh)	0	-	-	0	0.1	0	0.1	0	-	-

Intersection												
Int Delay, s/veh	1.5											
Movement	EBL	EBT	EBR	WBL	WBT	WBR	NBL	NBT	NBR	SBL	SBT	SBR
Lane Configurations		↕	↕		↕	↕	↕	↕↕	↕	↕	↕↕	↕
Traffic Vol, veh/h	8	3	15	2	7	15	26	299	0	6	113	11
Future Vol, veh/h	8	3	15	2	7	15	26	299	0	6	113	11
Conflicting Peds, #/hr	0	0	0	0	0	0	0	0	0	0	0	0
Sign Control	Stop	Stop	Stop	Stop	Stop	Stop	Free	Free	Free	Free	Free	Free
RT Channelized	-	-	None	-	-	None	-	-	None	-	-	None
Storage Length	-	-	0	-	-	0	0	-	0	0	-	0
Veh in Median Storage, #	-	0	-	-	0	-	-	0	-	-	0	-
Grade, %	-	0	-	-	0	-	-	0	-	-	0	-
Peak Hour Factor	92	92	92	92	92	92	92	92	92	92	92	92
Heavy Vehicles, %	2	2	2	2	2	2	2	2	2	2	2	2
Mvmt Flow	9	3	16	2	8	16	28	325	0	7	123	12

Major/Minor	Minor2		Minor1		Major1			Major2				
Conflicting Flow All	360	518	62	458	530	163	135	0	0	325	0	0
Stage 1	137	137	-	381	381	-	-	-	-	-	-	-
Stage 2	223	381	-	77	149	-	-	-	-	-	-	-
Critical Hdwy	7.54	6.54	6.94	7.54	6.54	6.94	4.14	-	-	4.14	-	-
Critical Hdwy Stg 1	6.54	5.54	-	6.54	5.54	-	-	-	-	-	-	-
Critical Hdwy Stg 2	6.54	5.54	-	6.54	5.54	-	-	-	-	-	-	-
Follow-up Hdwy	3.52	4.02	3.32	3.52	4.02	3.32	2.22	-	-	2.22	-	-
Pot Cap-1 Maneuver	571	460	990	486	453	853	1447	-	-	1231	-	-
Stage 1	852	782	-	613	612	-	-	-	-	-	-	-
Stage 2	759	612	-	923	773	-	-	-	-	-	-	-
Platoon blocked, %								-	-	-	-	-
Mov Cap-1 Maneuver	542	449	990	466	442	853	1447	-	-	1231	-	-
Mov Cap-2 Maneuver	542	449	-	466	442	-	-	-	-	-	-	-
Stage 1	836	777	-	601	600	-	-	-	-	-	-	-
Stage 2	721	600	-	899	768	-	-	-	-	-	-	-

Approach	EB		WB		NB			SB		
HCM Control Delay, s	10.2		10.8		0.6			0.4		
HCM LOS	B		B							

Minor Lane/Major Mvmt	NBL	NBT	NBR	EBLn1	EBLn2	WBLn1	WBLn2	SBL	SBT	SBR
Capacity (veh/h)	1447	-	-	513	990	447	853	1231	-	-
HCM Lane V/C Ratio	0.02	-	-	0.023	0.016	0.022	0.019	0.005	-	-
HCM Control Delay (s)	7.5	-	-	12.2	8.7	13.2	9.3	7.9	-	-
HCM Lane LOS	A	-	-	B	A	B	A	A	-	-
HCM 95th %tile Q(veh)	0.1	-	-	0.1	0.1	0.1	0.1	0	-	-

Intersection												
Int Delay, s/veh	5.8											
Movement	EBL	EBT	EBR	WBL	WBT	WBR	NBL	NBT	NBR	SBL	SBT	SBR
Lane Configurations		↔						↑↑	↑		↑	
Traffic Vol, veh/h	128	0	174	0	0	0	0	217	1	1	69	0
Future Vol, veh/h	128	0	174	0	0	0	0	217	1	1	69	0
Conflicting Peds, #/hr	0	0	0	0	0	0	0	0	0	0	0	0
Sign Control	Stop	Stop	Stop	Free	Free	Free	Free	Free	Free	Free	Free	Free
RT Channelized	-	-	None	-	-	None	-	-	None	-	-	None
Storage Length	-	-	-	-	-	-	-	-	0	-	-	-
Veh in Median Storage, #	-	0	-	-	-	-	-	0	-	-	0	-
Grade, %	-	0	-	-	0	-	-	0	-	-	0	-
Peak Hour Factor	92	92	92	92	92	92	92	92	92	92	92	92
Heavy Vehicles, %	2	2	2	2	2	2	2	2	2	2	2	2
Mvmt Flow	139	0	189	0	0	0	0	236	1	1	75	0

Major/Minor	Minor2			Major1			Major2		
Conflicting Flow All	195	314	75	-	0	0	237	0	0
Stage 1	77	77	-	-	-	-	-	-	-
Stage 2	118	237	-	-	-	-	-	-	-
Critical Hdwy	6.63	6.53	6.23	-	-	-	4.13	-	-
Critical Hdwy Stg 1	5.43	5.53	-	-	-	-	-	-	-
Critical Hdwy Stg 2	5.83	5.53	-	-	-	-	-	-	-
Follow-up Hdwy	3.519	4.019	3.319	-	-	-	2.219	-	-
Pot Cap-1 Maneuver	785	601	986	0	-	-	1329	-	0
Stage 1	946	831	-	0	-	-	-	-	0
Stage 2	895	708	-	0	-	-	-	-	0
Platoon blocked, %									
Mov Cap-1 Maneuver	784	0	986	-	-	-	1329	-	-
Mov Cap-2 Maneuver	784	0	-	-	-	-	-	-	-
Stage 1	946	0	-	-	-	-	-	-	-
Stage 2	894	0	-	-	-	-	-	-	-

Approach	EB	NB	SB
HCM Control Delay, s	11.4	0	0.1
HCM LOS	B		

Minor Lane/Major Mvmt	NBT	NBR	EBLn1	SBL	SBT
Capacity (veh/h)	-	-	889	1329	-
HCM Lane V/C Ratio	-	-	0.369	0.001	-
HCM Control Delay (s)	-	-	11.4	7.7	-
HCM Lane LOS	-	-	B	A	-
HCM 95th %tile Q(veh)	-	-	1.7	0	-

Intersection												
Int Delay, s/veh	2											
Movement	EBL	EBT	EBR	WBL	WBT	WBR	NBL	NBT	NBR	SBL	SBT	SBR
Lane Configurations		↔						↑↑	↑		↑	
Traffic Vol, veh/h	49	0	52	0	0	0	0	317	9	0	78	0
Future Vol, veh/h	49	0	52	0	0	0	0	317	9	0	78	0
Conflicting Peds, #/hr	0	0	0	0	0	0	0	0	0	0	0	0
Sign Control	Stop	Stop	Stop	Free	Free	Free	Free	Free	Free	Free	Free	Free
RT Channelized	-	-	None	-	-	None	-	-	None	-	-	None
Storage Length	-	-	-	-	-	-	-	-	0	-	-	-
Veh in Median Storage, #	-	0	-	-	-	-	-	0	-	-	0	-
Grade, %	-	0	-	-	0	-	-	0	-	-	0	-
Peak Hour Factor	92	92	92	92	92	92	92	92	92	92	92	92
Heavy Vehicles, %	2	2	2	2	2	2	2	2	2	2	2	2
Mvmt Flow	53	0	57	0	0	0	0	345	10	0	85	0

Major/Minor	Minor2			Major1			Major2		
Conflicting Flow All	258	440	85	-	0	0	-	-	0
Stage 1	85	85	-	-	-	-	-	-	-
Stage 2	173	355	-	-	-	-	-	-	-
Critical Hdwy	6.63	6.53	6.23	-	-	-	-	-	-
Critical Hdwy Stg 1	5.43	5.53	-	-	-	-	-	-	-
Critical Hdwy Stg 2	5.83	5.53	-	-	-	-	-	-	-
Follow-up Hdwy	3.519	4.019	3.319	-	-	-	-	-	-
Pot Cap-1 Maneuver	720	510	973	0	-	-	0	-	0
Stage 1	938	824	-	0	-	-	0	-	0
Stage 2	840	629	-	0	-	-	0	-	0
Platoon blocked, %									
Mov Cap-1 Maneuver	720	0	973	-	-	-	-	-	-
Mov Cap-2 Maneuver	720	0	-	-	-	-	-	-	-
Stage 1	938	0	-	-	-	-	-	-	-
Stage 2	840	0	-	-	-	-	-	-	-

Approach	EB	NB	SB
HCM Control Delay, s	10	0	0
HCM LOS	B		

Minor Lane/Major Mvmt	NBT	NBR	EBLn1	SBT
Capacity (veh/h)	-	-	831	-
HCM Lane V/C Ratio	-	-	0.132	-
HCM Control Delay (s)	-	-	10	-
HCM Lane LOS	-	-	B	-
HCM 95th %tile Q(veh)	-	-	0.5	-

Intersection												
Int Delay, s/veh	0.7											
Movement	EBL	EBT	EBR	WBL	WBT	WBR	NBL	NBT	NBR	SBL	SBT	SBR
Lane Configurations					↕			↕			↑	↗
Traffic Vol, veh/h	0	0	0	4	0	5	23	94	134	0	71	35
Future Vol, veh/h	0	0	0	4	0	5	23	94	134	0	71	35
Conflicting Peds, #/hr	0	0	0	0	0	0	0	0	0	0	0	0
Sign Control	Free	Free	Free	Stop	Stop	Stop	Free	Free	Free	Free	Free	Free
RT Channelized	-	-	None	-	-	None	-	-	None	-	-	None
Storage Length	-	-	-	-	-	-	-	-	-	-	-	0
Veh in Median Storage, #	-	-	-	-	0	-	-	0	-	-	0	-
Grade, %	-	0	-	-	0	-	-	0	-	-	0	-
Peak Hour Factor	92	92	92	92	92	92	92	92	92	92	92	92
Heavy Vehicles, %	2	2	2	2	2	2	2	2	2	2	2	2
Mvmt Flow	0	0	0	4	0	5	25	102	146	0	77	38

Major/Minor	Minor1	Major1	Major2		
Conflicting Flow All	321	340	175	115	0
Stage 1	225	225	-	-	-
Stage 2	96	115	-	-	-
Critical Hdwy	6.42	6.52	6.22	4.12	-
Critical Hdwy Stg 1	5.42	5.52	-	-	-
Critical Hdwy Stg 2	5.42	5.52	-	-	-
Follow-up Hdwy	3.518	4.018	3.318	2.218	-
Pot Cap-1 Maneuver	673	582	868	1474	-
Stage 1	812	718	-	-	0
Stage 2	928	800	-	-	0
Platoon blocked, %					-
Mov Cap-1 Maneuver	660	0	868	1474	-
Mov Cap-2 Maneuver	660	0	-	-	-
Stage 1	796	0	-	-	-
Stage 2	928	0	-	-	-

Approach	WB	NB	SB
HCM Control Delay, s	9.8	0.7	0
HCM LOS	A		

Minor Lane/Major Mvmt	NBL	NBT	NBRWBLn1	SBT	SBR
Capacity (veh/h)	1474	-	-	761	-
HCM Lane V/C Ratio	0.017	-	-	0.013	-
HCM Control Delay (s)	7.5	0	-	9.8	-
HCM Lane LOS	A	A	-	A	-
HCM 95th %tile Q(veh)	0.1	-	-	0	-

Intersection												
Int Delay, s/veh	2.7											
Movement	EBL	EBT	EBR	WBL	WBT	WBR	NBL	NBT	NBR	SBL	SBT	SBR
Lane Configurations					↕			↕			↑	↗
Traffic Vol, veh/h	0	0	0	6	0	4	161	132	80	0	74	50
Future Vol, veh/h	0	0	0	6	0	4	161	132	80	0	74	50
Conflicting Peds, #/hr	0	0	0	0	0	0	0	0	0	0	0	0
Sign Control	Free	Free	Free	Stop	Stop	Stop	Free	Free	Free	Free	Free	Free
RT Channelized	-	-	None	-	-	None	-	-	None	-	-	None
Storage Length	-	-	-	-	-	-	-	-	-	-	-	0
Veh in Median Storage, #	-	-	-	-	0	-	-	0	-	-	0	-
Grade, %	-	0	-	-	0	-	-	0	-	-	0	-
Peak Hour Factor	92	92	92	92	92	92	92	92	92	92	92	92
Heavy Vehicles, %	2	2	2	2	2	2	2	2	2	2	2	2
Mvmt Flow	0	0	0	7	0	4	175	143	87	0	80	54

Major/Minor	Minor1	Major1	Major2			
Conflicting Flow All	644	671	187	134	0	0
Stage 1	537	537	-	-	-	-
Stage 2	107	134	-	-	-	-
Critical Hdwy	6.42	6.52	6.22	4.12	-	-
Critical Hdwy Stg 1	5.42	5.52	-	-	-	-
Critical Hdwy Stg 2	5.42	5.52	-	-	-	-
Follow-up Hdwy	3.518	4.018	3.318	2.218	-	-
Pot Cap-1 Maneuver	437	378	855	1451	-	0
Stage 1	586	523	-	-	-	0
Stage 2	917	785	-	-	-	0
Platoon blocked, %					-	-
Mov Cap-1 Maneuver	376	0	855	1451	-	-
Mov Cap-2 Maneuver	376	0	-	-	-	-
Stage 1	504	0	-	-	-	-
Stage 2	917	0	-	-	-	-

Approach	WB	NB	SB
HCM Control Delay, s	12.6	3.4	0
HCM LOS	B		

Minor Lane/Major Mvmt	NBL	NBT	NBRWBLn1	SBT	SBR
Capacity (veh/h)	1451	-	-	485	-
HCM Lane V/C Ratio	0.121	-	-	0.022	-
HCM Control Delay (s)	7.8	0	-	12.6	-
HCM Lane LOS	A	A	-	B	-
HCM 95th %tile Q(veh)	0.4	-	-	0.1	-

SB 610 - Water Supply Assessment
For
VEGA SES 4 Solar Energy Storage Project

June 11, 2021

Prepared For:

Imperial Irrigation District
333 East Barioni Boulevard
Imperial, California 92251

VEGA SES 4 Solar Energy Storage Project

Contents

- **To properly update automated fields and TOC – Highlight (Select) entire WSA document and Select F9 and then select update entire table for the TOC, list of Figures and list of Tables, when prompted.**

PURPOSE OF WATER SUPPLY ASSESSMENT	6
Project Determination According to SB 610 - Water Supply Assessment	6
EXECUTIVE SUMMARY	8
PROJECT DESCRIPTION.....	9
Description of IID Service Area	13
Climate Factors	13
Imperial Valley Historic and Future Land and Water Uses.....	17
Imperial Integrated Regional Water Management Plan (October 2012).....	18
IID Interim Water Supply Policy for Non-Agricultural Projects (September 2009)	20
IID Temporary Land Conversion Following Policy (May 2012).....	21
IMPERIAL IRRIGATION DISTRICT’S WATER RIGHTS	22
California Law	22
Law of the River	23
IMPERIAL IRRIGATION DISTRICT WATER SUPPLY AND DEMAND	32
WATER AVAILABILITY – NORMAL YEAR	33
EXPECTED WATER AVAILABILITY – SINGLE DRY AND MULTIPLE DRY YEARS.....	35
Equitable Distribution Plan (EDP)	36
Water Management under Inadvertent Overrun Payback Policy (IOPP).....	37
PROJECT WATER AVAILABILITY FOR A 20-YEAR PERIOD TO MEET PROJECTED DEMANDS	38
EXPECTED WATER DEMANDS FOR THE PROPOSED PROJECT.....	40
IID’S ABILITY TO MEET DEMANDS WITH WATER SUPPLY	41
Expanding Water Supply Portfolio.....	44
IID Near Term Water Supply Projections.....	46
IMPERIAL IRRIGATION DISTRICT FINDINGS	47
ASSESSMENT CONCLUSION	49
RESOURCES AND REFERENCES	50
ATTACHMENTS	51

Figures

Figure 1. Project Site Regional Location.....	10
Figure 2. Aerial Map of Project Vicinity	11
Figure 3. Project Layout/Site Plan	12
Figure 4. IID Imperial Unit Boundary and Canal Network.....	14
Figure 5. Major Colorado River Reservoir Storage Facilities and Basin Location Map.....	29
Figure 6. Lake Mead Water Elevation Levels 2020 visit< http://www.arachnoid.com/NaturalResources/index.html >	32
Figure 7. Lake Mead IOPP Schematic.....	37

Tables

Table 1. Climate Characteristics, Imperial, CA 100-Year Record, 1921-2020.....	15
Table 2. IID Areawide Annual Precipitation (In), (1991-2019)	15
Table 3. Monthly Mean Temperature (°F) – Imperial, CA 10-Year, 30-Year & 100-Year (2011-2020, 1991-2020, 1921-2020)	16
Table 4. Monthly Mean Rainfall (In) – Imperial, CA 10-Year, 30-Year & 100-Year (2011-2020, 1991-2020, 1921-2020)	16
Table 5. Non-Agricultural Water Demand within IID Water Service Area, 2015-2055 (KAFY)	19
Table 6. Historic and forecasted Agricultural Water Consumptive Use and Delivery Demand within IID Water Service Area, 2015-2055 (KAFY)	20
Table 7. IID System Operations Consumptive Use within IID Water Service Area and from AAC at Mesa Lateral 5 to Imperial Dam, (KAF), 2020	20
Table 8. Interim Water Supply Policy 2021 Annual Non-Agricultural Water Supply Development Fee Schedule	21
Table 9. CRWDA Annual 4.4 MAF Apportionment (Priorities 1 to 4) for California Agencies (AFY).....	27
Table 10. Unregulated Inflow to Lake Powell, Percent of Historic Average, 2000-2020.....	28
Table 11. IID Historic and Forecast Net Consumptive Use for Normal Year, Single-Dry Year and Multiple-Dry Year Water Supply, 2003-2037, et seq. (CRWDA Exhibit B)	33
Table 12. IID Annual Rainfall (In), Net Consumptive Use and Underrun/Overrun Amounts (AF), 1988-2020.....	35
Table 13. IID Inadvertent Overrun Payback to the Colorado River under the IOPP, 2012-2020.....	38
Table 14. Project Water Uses (AFY)	40
Table 15. IID System Operations Consumptive Use within IID Water Service Area and from AAC at Mesa Lateral 5 to Imperial Dam, (KAF), 2020	41
Table 16. IID Historic and Forecasted Consumptive Use vs CRWDA Exhibit B IID Net Available Consumptive Use, volumes at Imperial Dam (KAFY), 2015-2055 Next Update in 2021 thru 2020	42
Table 17. 2020 Approved Water Order, Actual CU (Decree Accounting Report) and IID Underrun, KAF at Imperial Dam	42
Table 18. IID Capital Project Alternatives and Cost (May 2009 price levels \$).....	45

Attachments

Attachment A: IID Interim Water Supply Policy for Non-Agricultural Projects

Acronyms

AF	Acre-Foot or Acre-Feet
AFY	Acre-Feet per Year
AOP	Annual Operations Plan
CAP	Central Arizona Project
CDCR	California Department of Corrections and Rehabilitation
CDPH	California Department of Public Health
CDWR	California Department of Water Resources
CEQA	California Environmental Quality Act
CRWDA	Colorado River Water Delivery Agreement
CUP	Conditional Use Permit
CVWD	Coachella Valley Water District
EDP	IID Equitable Distribution Plan
EIS	Environmental Impact Statement
ICPDS	Imperial County Planning and Development Services
ICS	Intentionally Created Surplus
IID	Imperial Irrigation District
IOPP	Inadvertent Overrun Payback Policy
ISG	Interim Surplus Guidelines
IRWMP	Integrated Regional Water Management Plan
IWSP	Interim Water Supply Policy
KAF	Thousand Acre Feet
LAFCO	Local Agency Formation Commission
LCR	Lower Colorado Region
MCI	Municipal, commercial, industrial
MGD	Million Gallons per Day
MW	Megawatt
MWD	Metropolitan Water District of Southern California
NAF	Naval Air Facility
PVID	Palo Verde Irrigation District
QSA/	Quantification Settlement Agreement and Related Agreements
TA	Transfer Agreements
SB	Senate Bill
SDCWA	San Diego County Water Authority
SNWA	Southern Nevada Water Authority
TLCFP	Temporary Land Conversion Following Policy
USBR	United States Bureau of Reclamation
USEPA	United States Environmental Protection Agency
WSA	Water Supply Assessment
CWC	California Water Code

PURPOSE OF WATER SUPPLY ASSESSMENT

This Water Supply Assessment (WSA) was prepared for the Imperial Irrigation District (Lead Agency) by ECORP Consulting, Inc., regarding the Vega SES 4, LLC VEGA SES 4 Solar Energy Storage Project (the “Applicant”). This study is a requirement of California law, specifically Senate Bill 610 (referred to as SB 610). SB 610 is an act that amended Section 21151.9 of the Public Resources Code, and Sections 10631, 10656, 10910, 10911, 10912, and 10915 of the Water Code. SB 221 is an act that amended Section 11010 of the Business and Professions Code, while amending Section 65867.5 and adding Sections 66455.3 and 66473.7 to the Government Code. SB 610 was approved by the Governor and filed with the Secretary of State on October 9, 2001, and became effective January 1, 2002.¹ SB 610 requires a lead agency, to determine that a project (as defined in CWC Section 10912) subject to California Environmental Quality Act (CEQA), to identify any public water system that may supply water for the project and to request the applicants to prepare a specified water supply assessment.

This study has been prepared pursuant to the requirements of CWC Section 10910, as amended by SB 610 (Costa, Chapter 643, Stats. 2001). The purpose of SB 610 is to advance water supply planning efforts in the State of California; therefore, SB 610 requires the Lead Agency, to identify any public water system or water purveyor that may supply water for the project and to prepare the WSA after a consultation. Once the water supply system is identified and water usage is established for construction and operations for the life of the project, the lead agency is then able to coordinate with the local water supplier and make informed land use decisions to help provide California’s cities, farms and rural communities with adequate water supplies.

Under SB 610, water supply assessments must be furnished to local governments for inclusion in any environmental documentation for certain projects (as defined in California Water Code (CWC) Section 10912 [a]) that are subject to the California Environmental Quality Act (CEQA). Due to increased water demands statewide, this water bill seeks to improve the link between information on water availability and certain land use decisions made by cities and counties. This bill takes a significant step toward managing the demand placed on California’s water supply. It provides further regulations and incentives to preserve and protect future water needs. Ultimately, this bill will coordinate local water supply and land use decisions to help provide California’s cities, farms, rural communities and industrial developments with adequate long-term water supplies. The WSA will allow the lead agency to determine whether water supplies will be sufficient to satisfy the demands of the project, in addition to existing and planned future uses.

Project Determination According to SB 610 - Water Supply Assessment

With the introduction of SB 610, any project under the California Environmental Quality Act (CEQA) shall provide a Water Supply Assessment if the project meets the definition of CWC § 10912. Water Code

¹SB 610 amended Section 21151.9 of the California Public Resources Code, and amended Sections 10631, 10656, 10910, 10911, 10912, and 10915, repealed Section 10913, and added and amended Section 10657 of the Water Code. SB 610 was approved by California Governor Gray Davis and filed with the Secretary of State on October 9, 2001.

section 10911(c) requires for that the lead agency “determine, based on the entire record, whether projected water supplies will be sufficient to satisfy the demands of the project, in addition to existing and planned future uses.” Specifically, Water Code section 10910(c)(3) states that “If the projected water demand associated with the proposed project was not accounted for in the most recently adopted urban water management plan, or the public water system has no urban water management plan, the water supply assessment for the project shall include a discussion with regard to whether the total projected water supplies, determined to be available by the city or county for the project during normal, single dry, and multiple dry water years during a 20 year projection, will meet the projected water demand associated with the proposed project, in addition to the public water system’s existing and planned future uses, including agricultural and manufacturing uses.”

After review of CWC § 10912a, and Section 10912 (a)(5)(B), it was determined that the Vega SES 4, LLC VEGA SES 4 Solar Energy Storage Project is deemed a project as it is considered an industrial use that will occupy more than 40 acres of land.

EXECUTIVE SUMMARY

Imperial Irrigation District has requested a WSA as part of the environmental review for the proposed Vega SES 4, LLC VEGA SES 4 Solar Energy Storage Project (“Project”). This study is intended for use by Imperial County Planning and Development Services in its evaluation of water supplies for existing and future land uses. The evaluation examines the following water elements:

- Water availability during a normal year
- Water availability during a single dry year, and multiple dry water years
- Water availability during a 20-year projection to meet existing demands
- Expected 20-year water demands of the Project
- Reasonably foreseeable planned future water demands to be served by the Imperial Irrigation District

The proposed Project site is located within Imperial Irrigation District’s (IID) Imperial Unit and district boundary and as such is eligible to receive water service. IID has adopted an Interim Water Supply Policy (IWSP) for Non-Agricultural Projects, from which water supplies can be contracted to serve new developments within IID’s water service area. For applications processed under the IWSP, applicants shall be required to pay a processing fee and, after IID board approval of the corresponding agreement, will be required to pay a reservation fee(s) and annual water supply development fees.

The IWSP sets aside 25,000 acre-feet annually (AFY) of IID’s Colorado River water supply to serve new non- agricultural projects. As of April 2021, a balance of 23,800 AFY remain available under the IWSP for new non-agricultural projects ensuring reasonably sufficient supplies for such projects. The proposed Project water demand of approximately 275 AF during an 18-month construction period and up to 10 AF/year for ongoing operations during the 30-year projected Project life represents 1.2% and 0.4 % of the annual unallocated supply set aside for new non-agricultural projects. Thus, the proposed Project’s estimated water demand would not affect IID’s ability to provide water to other users in IID’s water service area.

PROJECT DESCRIPTION

Vega SES 4, LLC is proposing to construct and operate a solar energy generation and storage facility on approximately 531.53 acres of private lands in the Imperial Valley in Imperial County. The Project would be located between the California/Mexico border and the All-American Canal, on the California side. It is approximately 10 miles east of Calexico in Sections 10, 11, 14, 15, and 16 of Township 17 South, Range 16 East of the San Bernardino Base and Meridian (SBB&M) of the “Bonds Corner” 7.5-minute topographic quadrangle. The Project would be located on Imperial County Assessor’s Parcel Numbers (APNs) 059-300-015-000 (approximately 301.73 acres), 059-300-017-000 (approximately 148.88 acres) and 059-290-010-000 (approximately 80.92 acres), all of which are currently owned by Tammy Cheri Slater and Jimmie R. Doyle (co-trustees of the Survivors Trust under the Doyle Family 2010 Trust dated August 13, 2010). (**Figure 1.** Site Regional Location, and **Figure 2.** Aerial View of Project Site and Vicinity). The Project would include approximately 313,600 photovoltaic solar cells, approximately 135 energy storage battery containers, and related electrical power interconnection and transmission facilities. The electrical energy produced by the Project would be conducted through the proposed 92 kilovolt (kV) generator intertie (“gen-tie”) line and delivered to the Imperial Irrigation District (IID) 92 kV “P” line. (**Figure 3.** Project Layout/Site Plan).

The solar energy storage facility involves a Conditional Use Permit from Imperial County that will allow for construction and operation of the Project over its projected 30-year duration.

Domestic water and sanitation facilities would be required during construction. These would be provided through bottled water and portable facilities. A domestic/potable water connection would not be required.

The Project will need to contract with IID to deliver up to 275 AF of untreated water during the 18-month construction phase for dust control and soil conditioning, and up to 10 AFY of untreated water during the operation phase to wash the PV modules. Untreated water would be provided via the All American Canal. It is anticipated that water would be pumped directly into water trucks from the canal.

This WSA does not include an analysis of water supply for any other ancillary uses, including temporary potable and sanitary supply during the 18-month construction period.

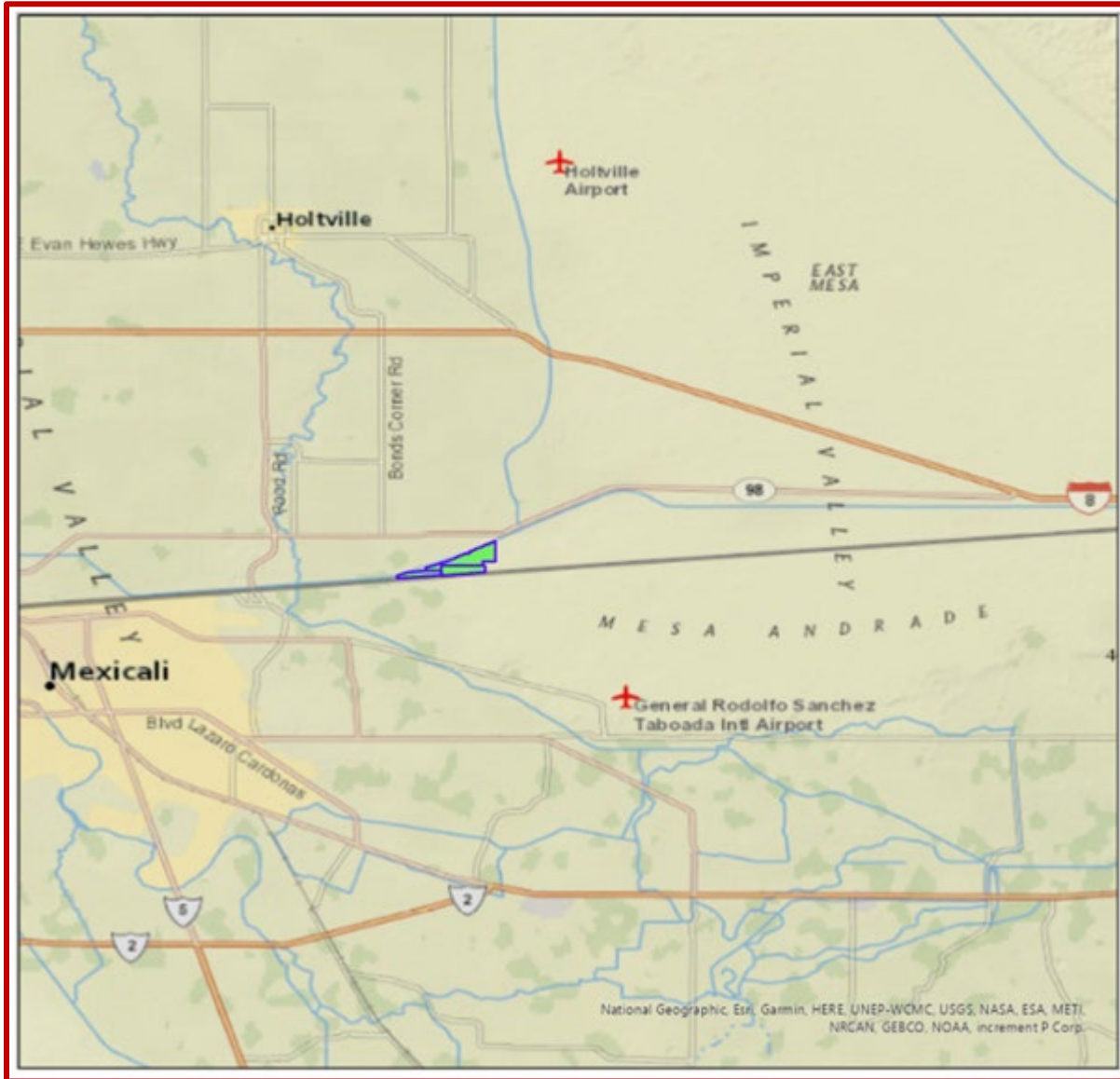


Figure 1. Project Site Regional Location

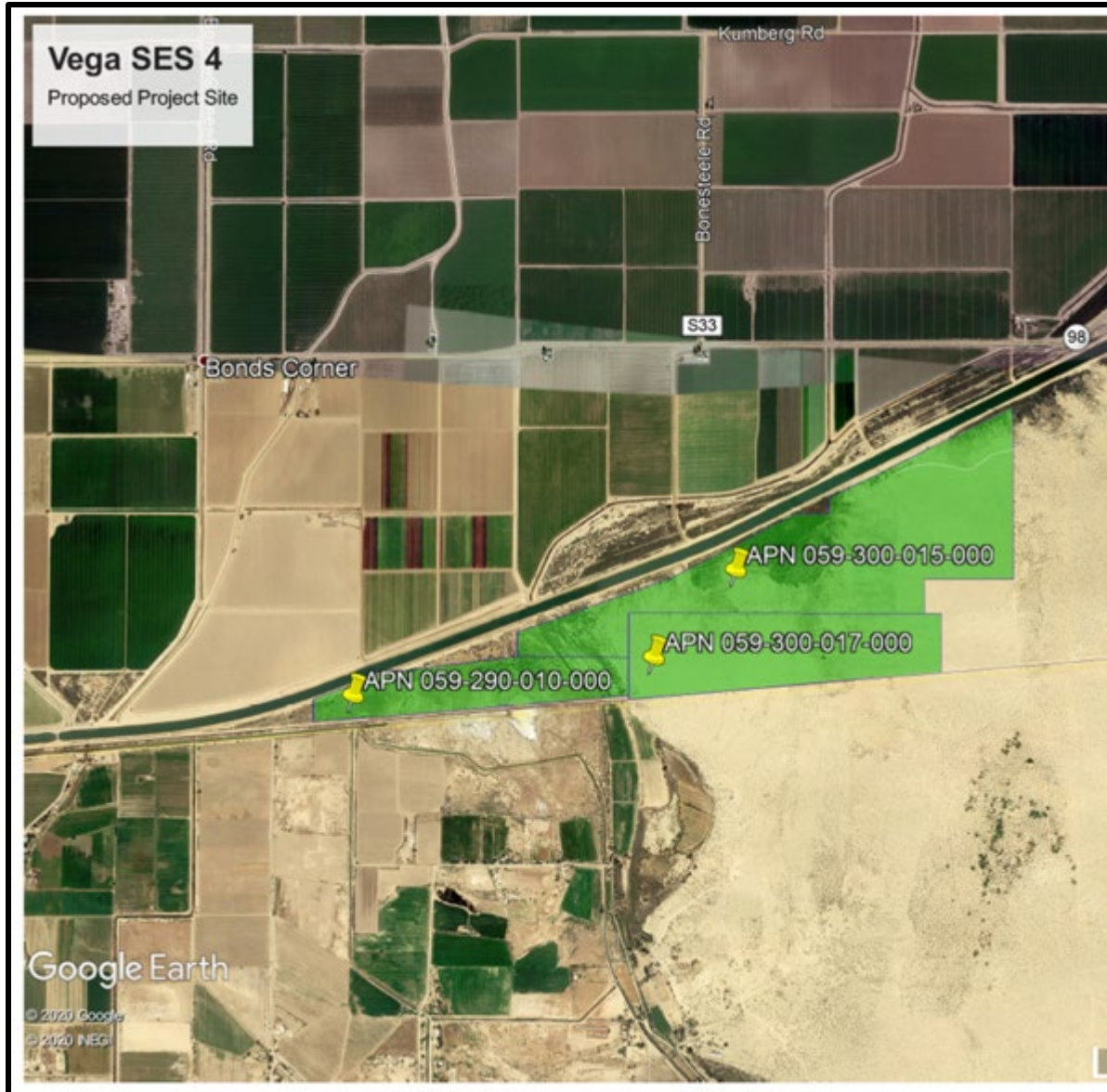


Figure 2. Aerial Map of Project Vicinity

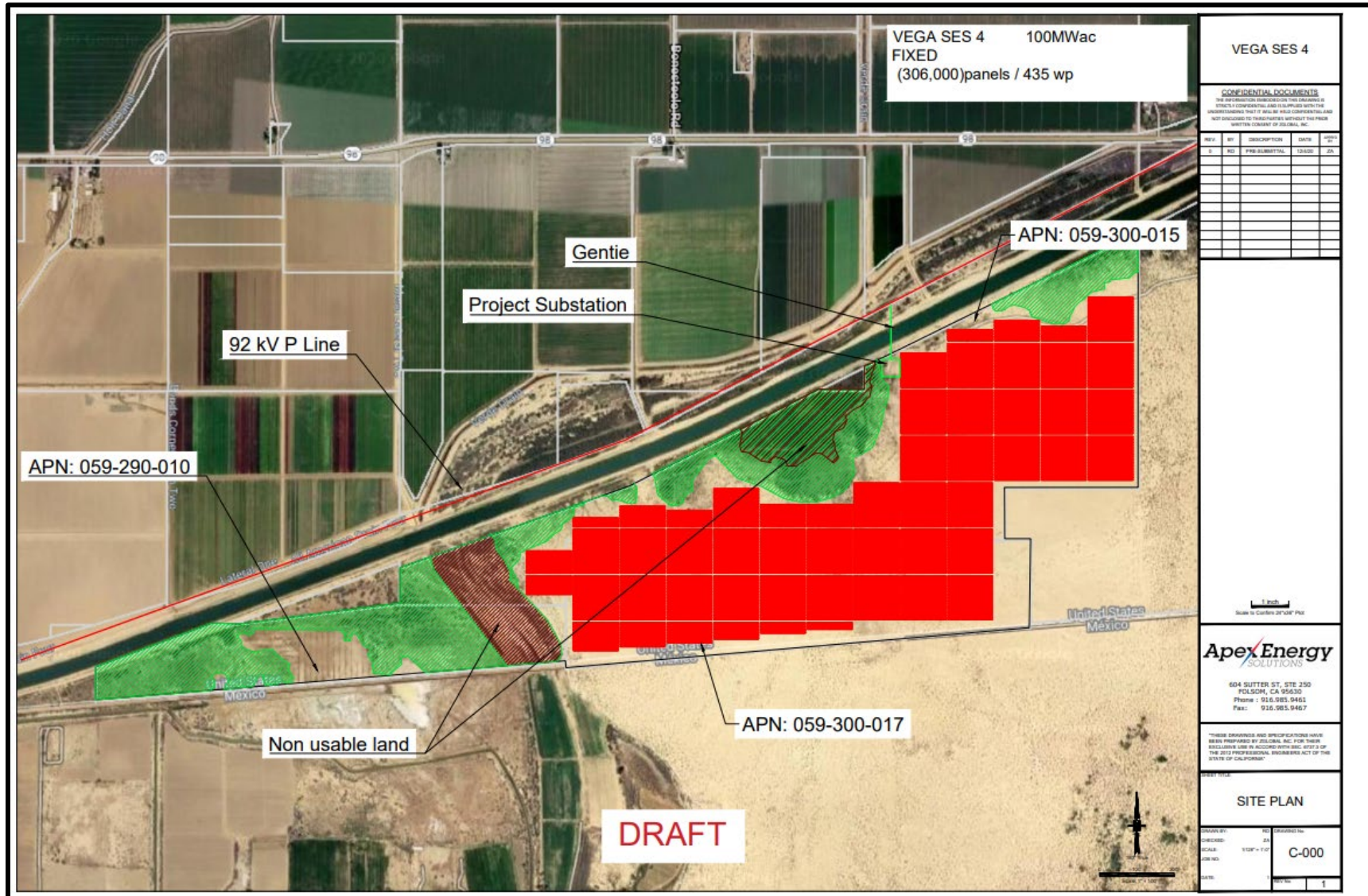


Figure 3. Project Layout/Site Plan

Description of IID Service Area

The proposed Project site is located in Imperial County in the southeastern corner of California. The County is comprised of approximately 4,597 square miles or 2,942,080 acres.² Imperial County is bordered by San Diego County to the west, Riverside County to the north, the Colorado River/Arizona boundary to the east, and 84 miles of International Boundary with the Republic of Mexico to the south. Approximately fifty percent of Imperial County is undeveloped land under federal ownership and jurisdiction. The Salton Sea accounts for approximately 11 percent of Imperial County's surface area. In 2020, sixteen percent (16%) of the area was in irrigated agriculture (466,325 acres), including 14,676 acres of the Yuma Project, some 35 sections or 5,600 acres served by Palo Verde Irrigation District (PVID), and 446,049 acres served by IID.³

The area served by IID is located in the Imperial Valley, which is generally contiguous with IID's Imperial Unit, lies south of the Salton Sea, north of the U.S./Mexico International Border, and generally in the 658,942 acre area between IID's Westside Main and East Highline Canals.⁴ In 2020, IID delivered untreated water to 494,921 net irrigated acres, predominantly in the Imperial Valley, along with small areas of East and West Mesa land.

The developed area consists of seven incorporated cities (Brawley, Calexico, Calipatria, El Centro, Holtville, Imperial and Westmorland), three unincorporated communities (Heber, Niland and Seeley), and three institutions (Naval Air Facility [NAF] El Centro, Calipatria CDCR, and Centinela CDCR) and supporting facilities. **Figure 4** provides a map of the IID Imperial Unit boundary, as well as cities, communities and main canals.

Climate Factors

Imperial Valley, located in the Northern Sonoran Desert, which has a subtropical desert climate is characterized by hot, dry summers and mild winters. Clear and sunny conditions typically prevail, and frost is rare. The region receives 85 to 90 percent of possible sunshine each year, the highest in the United States. Winter temperatures are mild rarely dropping below 32°F, but summer temperatures are very hot, with more than 100 days over 100°F each year. The remainder of the year has a relatively mild climate with temperatures averaging in the mid-70s.

The 100-year average climate characteristics are provided in **Table 1**. Rainfall contributes around 50,000 AF of effective agricultural water per inch of rain. Most rainfall occurs from November through March; however, summer storms can be significant in some years. Annual areawide rainfall is shown in **Table 2**.

² *Imperial County General Plan, Land Use Element 2008 Update*

³ *USBR website: [Yuma Project](#). 7 June 2017, PVID contact for acreage. 26 April 2021.*

⁴ *[IID Annual Inventory of Areas Receiving Water Years 2020, 2019, 2018](#)*

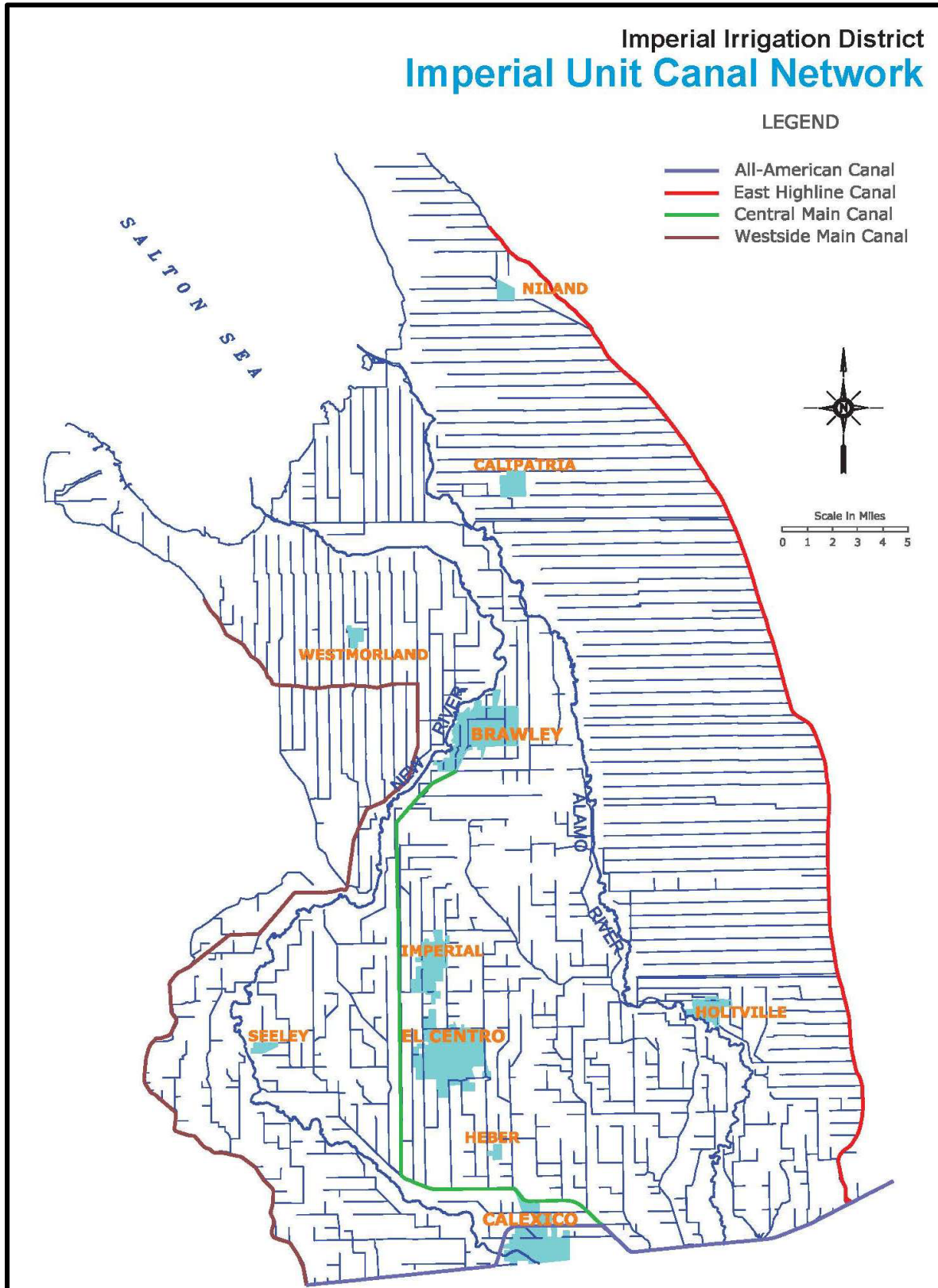


Figure 4. IID Imperial Unit Boundary and Canal Network

The thirty-year, 1991-2020, average annual air temperature was 73.7°F, and average annual rainfall was 2.70 inches, see Table 3 and Table 4. This record shows that while average annual rainfall has fluctuated, the 10-year average temperatures have slightly increased over the 30-year averages.

Table 1. Climate Characteristics, Imperial, CA 100-Year Record, 1920-2020

Climate Characteristic	Annual Value
Average Precipitation (100-year record, 1921-2020)	2.79 inches (In)
Minimum Temperature, Jan 1937	16 °F
Maximum Temperature, July 1995	121 °F
Average Minimum Temperature, 1921-2020	48.2 °F
Average Maximum Temperature, 1921-2020	98.3 °F
Average Temperature, 1921-2020	73.0 °F

Source: IID Imperial Weather Station Record

Table 2. IID Areawide Annual Precipitation (In), (1990-2020)

1990	1991	1992	1993	1994	1995	1996
1.646	3.347	4.939	2.784	1.775	1.251	0.685
1997	1998	1999	2000	2001	2002	2003
1.328	2.604	1.399	0.612	0.516	0.266	2.402
2004	2005	2006	2007	2008	2009	2010
4.116	4.140	0.410	1.331	1.301	0.619	3.907
2011	2012	2013	2014	2015	2016	2017
2.261	2.752	2.772	1.103	2.000	1.867	2.183
2018	2019	2020				
1.305	3.017	2.673				

Source: Computation based on polygon average of CIMIS as station came online in the WIS.⁵

Notable from Table 2 (above) and Table 3 (below) is that while average annual rainfall measured at IID Headquarters in Imperial, California, has been decreasing, monthly average temperatures are remarkably consistent.

⁵ From 1/1/1990-3/23/2004, 3 CIMIS stations: Seeley, Calipatria/Mulberry, Meloland; 3/24/2004-7/5/2009, 4 CIMIS stations (added Westmorland N.); 7/6/2009-12/1/2009, 3 CIMIS stations: Westmorland N. offline; 12/2/2009-2/31/2009, 4 CIMIS stations, Westmorland N. back online; 1/1/2010-9/20/2010.

Table 3. Monthly Mean Temperature (°F) – Imperial, CA 10-Year, 30-Year & 100-Year (2011-2020, 1991-2020, 1921-2020)

	Jan			Feb			Mar			Apr		
	Max	Min	Avg	Max	Min	Avg	Max	Min	Avg	Max	Min	Avg
10-year	82	32	57	84	35	60	93	42	67	100	47	73
30-year	81	34	57	84	37	60	92	41	66	99	47	71
100-year	80	31	55	86	34	60	91	40	64	99	46	71
	May			Jun			Jul			Aug		
	Max	Min	Avg	Max	Min	Avg	Max	Min	Avg	Max	Min	Avg
10-year	105	53	76	115	61	87	115	70	92	114	70	92
30-year	105	54	78	112	60	86	115	68	92	114	69	92
100-year	105	53	78	113	59	86	114	68	92	113	68	92
	Sep			Oct			Nov			Dec		
	Max	Min	Avg	Max	Min	Avg	Max	Min	Avg	Max	Min	Avg
10-year	111	62	87	101	52	76	91	39	64	80	32	55
30-year	110	62	87	102	50	76	90	39	64	79	32	55
100-year	110	60	86	101	49	75	89	38	63	80	32	56

Source: IID Imperial Headquarters Station Record (Data provided by IID staff)

Table 4. Monthly Mean Rainfall (In) – Imperial, CA 10-Year, 30-Year & 100-Year (2011-2020, 1991-2020, 1921-2020)

	Jan	Feb	Mar	Apr	May	Jun	Jul	Aug	Sep	Oct	Nov	Dec	Annual
10-year	0.33	0.26	0.22	0.12	0.08	0.01	0.22	0.30	0.28	0.02	0.26	0.42	2.44
30-year	0.50	0.43	0.31	0.09	0.06	0.00	0.14	0.19	0.26	0.15	0.22	0.40	2.70
100-year	0.39	0.38	0.25	0.11	0.03	0.00	0.12	0.33	0.36	0.25	0.21	0.51	2.79

Source: IID WIS: CIMIS stations polygon calculation (Data provided by IID staff).

Imperial Valley depends on the Colorado River for its water, which IID transports, untreated, to delivery gates for agricultural, municipal, industrial (including geothermal and solar energy), environmental (managed marsh), recreational (lakes), and other non-agricultural uses. IID supplies the cities, communities, institutions and Golden State Water (which includes all or portions Calipatria, Niland, and some adjacent Imperial County territory) with untreated water that they treat to meet state and federal drinking water guidelines before distribution to their customers. Industries outside the municipal areas treat the water to required standards of their industry. To comply with U.S. Environmental Protection Agency (USEPA) requirements and avoid termination of canal water service, residents in the IID water service area who do not receive treated water service must obtain alternative water service for drinking and cooking from a state-approved provider. To avoid penalties that could exceed \$25,000 a day, IID strictly enforces this rule. The IID Water Department tracks nearly 3,000 raw water service accounts required by the California Department of Public Health (CDPH) to have alternate state approved drinking water service. IID maintains a small-acreage pipe and drinking water database and provides an annual compliance update to CDPH.

Imperial Valley Historic and Future Land and Water Uses

Agricultural development in the Imperial Valley began at the turn of the twentieth century. In 2019, gross agricultural production for Imperial County was valued at \$2,015,843,000, of which approximately \$1,693,308,120 was produced in the IID water service area.⁶ While the agriculture-based economy is expected to continue, land use is projected to change somewhat over the years as industrial and/or alternative energy development and urbanization occur in rural areas and in areas adjacent to existing urban centers, respectively.

Imperial Valley's economy is gradually diversifying. Agriculture will likely continue to be the primary industry within the valley; however, two principal factors anticipated to reduce crop acreage are renewable energy (geothermal and solar) and urban development. Over the next twenty years, urbanization is expected to slightly decrease agriculture land use to provide space for an increase in residential, commercial and industrial uses. The transition from agricultural land use typically results in a net decrease in water demand for municipal, commercial, and solar energy development; and a net increase in water demand for geothermal energy development. Local energy resources include geothermal, wind, biomass and solar. The County General Plan provides for development of energy production centers or energy parks within Imperial County. Alternative energy facilities will help California meet its statutory and regulatory goals for increasing renewable power generation and use and decrease water demands in Imperial County.

The VEGA SES 4 Solar Storage Project is not located on land that is currently used for agriculture. Thus, the Project would not reduce agricultural production in the County. Apex Energy Solutions, LLC has identified the following additional objectives to complement the primary purpose of the Project:

- Assist California in meeting its current and future Renewable Portfolio Standard Goals.
- Site the Project in an area with excellent solar energy resources in order to maximize productivity.
- Use proven technology to reliably and economically produce electrical energy for a long period of time.
- Support greenhouse gas reduction goals of AB 32.
- Minimize environmental impacts and impacts to residential or commercial uses by locating in an area where there are few or no surrounding uses and limited potential to affect existing environment.

The IID Board has adopted the following policies and programs to address how to accommodate water demands under the terms of the QSA/ Transfers Agreements and minimize potential negative impacts on agricultural water uses:

⁶ [2019 Imperial County Crop and Livestock Report](#)

Imperial Integrated Regional Water Management Plan: adopted by the board on December 18, 2012, and by the County, the City of Imperial, to meet the basic requirement of California Department of Water Resources (CDWR) for an IRWM plan. In all, 14 local agencies adopted the 2012 Imperial IRWMP.

Interim Water Supply Policy for Non-Agricultural Projects: adopted by the board on September 29, 2009, to ensure sufficient water will be available for new development, in particular, anticipated renewable energy projects until the board selects and implements capital development projects such as those considered in the Imperial IRWMP.

Temporary Land Conversion Fallowing Policy: adopted by the board on May 8, 2012, and revised on March 29, 2016, to provide a framework for a temporary, long-term fallowing program to work in concert with the IWSP and IID's coordinated land use/water supply strategy.

Equitable Distribution Plan: adopted by the board on October 28, 2013, to provide a mechanism for IID to administer apportionment of the district's quantified annual supply of Colorado River water; the IID board approved a resolution repealing the Equitable Distribution Plan (EDP) on February 6, 2018.

In addition, water users within the IID service area are subject to the statewide requirement of reasonable and beneficial use of water under the California Constitution, Article X, section 2.

Imperial Integrated Regional Water Management Plan (October 2012)

The Imperial IRWMP serves as the governing document for regional water planning to meet present and future water resource needs and demands by addressing such issues as additional water supply options, demand management and determination and prioritization of uses and classes of service provided. In November 2012, the Imperial County Board of Supervisors approved the Imperial IRWMP, and the City of Imperial City Council and the IID Board of Directors approved it in December 2012. Approval by these three (3) stakeholders meets the basic requirement of California Department of Water Resources (CDWR) for an IRWMP. Through the IRWMP process, IID presented to the region stakeholders options in the event long-term water supply augmentation is needed, such as water storage and banking, recycling of municipal wastewater, and desalination of brackish water.⁷ As discussed herein, long term water supply augmentation is not anticipated to be necessary to meet proposed Project demands.

Chapter 5 of the 2012 Imperial IRWMP addresses water supplies (Colorado River and groundwater), demand, baseline and forecasted through 2050; and IID water budget. Chapter 12 addresses projects, programs and policies, and funding alternatives. Chapter 12 of the IRWMP lists, and Appendix N details, a set of capital projects that IID might pursue, including the amount of water that might result (AFY) and cost (\$/AF) if necessary. These also highlight potential capital improvement projects that could be implemented in the future.

⁷ October 2012 [Imperial Integrated Regional Water Management Plan](#), Chapter 12.

Imperial Valley historic 2015 and forecasted future for 2020 to 2055 non-agricultural water demand, are provided in **Table 5** in five-year increments. Total water demand for non-agricultural uses is projected to be 201.4 KAF in the year 2055. This is a forecasted increase in the use of non-agricultural water from 107.4 KAF for the period of 2015 to 2055.⁸ These values were modified from Chapter 5 of the Imperial IRWMP to reflect updated conditions from the IID Provisional Water Balance for calendar year 2015. Due to the recession in 2009 and other factors, non-agricultural growth projections have lessened since the 2012 Imperial IRWMP. Projections in **Table 5** have been adjusted (reduced by 3%) to reflect IID 2015 delivery data.

Table 5. Non-Agricultural Water Demand within IID Water Service Area, 2015-2055 (KAFY)

	2015	2020	2025	2030	2035	2040	2045	2050	2055
Municipal	30.0	30.9	36.8	39.8	41.5	46.3	51.7	57.8	61.9
Industrial	26.4	26.0	39.8	46.5	53.2	59.9	66.6	73.3	80.0
Other	5.5	6.5	5.5	5.5	5.5	5.5	5.5	5.5	5.5
Feedlots/Dairies	17.8	19.0	20.0	20.0	20.0	20.0	20.0	20.0	20.0
Envr Resources	8.3	9.2	12.0	12.0	12.0	12.0	12.0	12.0	12.0
Recreation	7.4	9.5	10.0	10.0	10.0	10.0	10.0	10.0	10.0
Service Pipes	12.0	12.0	12.0	12.0	12.0	12.0	12.0	12.0	12.0
Total Non Ag	107.4	113.1	136.1	145.8	154.2	165.7	177.8	190.6	201.4

Notes: 2015 non-agricultural water demands are from IID 2015 Provisional Water Balance rerun 03/28/2019 2020-2055 demands are modified from 2012 Imperial IRWMP Chapter 5, Table 5-22 p 5-50 based on IID 2015 Provisional Water Balance. Industrial Demand includes geothermal, but not solar, energy production. Next Update 2021

Agricultural evapotranspiration (ET) demand of approximately 1,476.4 KAF in 2015, decreased in 2020 to around 1,442.2 KAF. The termination of fallowing programs provided 103.5 KAF of water for Salton Sea mitigation in 2017. Forecasted agricultural ET remains constant, as reductions in water use are to come from efficiency conservation not reduction in agricultural production. Market forces and other factors may impact forecasted future water demand.

Table 6 provides the 2015 and 2020 historic and 2025-2055 forecasted agricultural consumptive use and delivery demand within the IID water service area. When accounting for agriculture ET, tailwater and tilewater, total agricultural consumptive use (CU) demand ranges from 2,157.9 KAF in 2015 to 2,208.5 KAF in 2055. Forecasted total agricultural delivery demand is around 1 KAFY higher than the CU demand, ranging from 2,158.9 KAF in 2015 to 2,209.5 KAF in 2055.

⁸ [Wistaria Solar Ranch, Final Environmental Impact Report](#), December 2014

Table 6. Historic and forecasted Agricultural Water Consumptive Use and Delivery Demand within IID Water Service Area, 2015-2055 (KAFY)

	2015	2020	2025	2030	2035	2040	2045	2050	2055
Ag ET from Delivered & Stored Soil Water	1,475.4	1,442.2	1,567.5	1,567.5	1,567.5	1,567.5	1,567.5	1,567.5	1,567.5
Ag Tailwater to Salton Sea	282.9	312.9	268.0	218.0	218.0	218.0	218.0	218.0	218.0
Ag Tilewater to Salton Sea	398.6	410.2	423.0	423.0	423.0	423.0	423.0	423.0	423.0
Total Ag CU Demand	2,157.9	2,165.4	2,258.5	2,208.5	2,208.5	2,208.5	2,208.5	2,208.5	2,208.5
<i>Subsurface Flow to Salton Sea</i>	<i>1.0</i>	<i>1.0</i>	<i>1.0</i>	<i>1.0</i>	<i>1.0</i>	<i>1.0</i>	<i>1.0</i>	<i>1.0</i>	<i>1.0</i>
Total Ag Delivery Demand	2,158.9	2,166.4	2,259.5	2,209.5	2,209.5	2,209.5	2,209.5	2,209.5	2,209.5

Notes: 2015 record from IID 2015 Provisional Water Balance rerun 06/28/2019; 2020-2055 forecasts from spreadsheet used to develop Figure 19, et seq. in Imperial IRWMP Chapter 5 (Data provided by IID staff). Next Update 2026

In addition to agricultural and non-agricultural water demands, system operation demand must be included to account for operational discharge, main and lateral canal seepage; and for AAC seepage, river evaporation and phreatophyte ET from Imperial Dam to IID’s measurement site at AAC Mesa Lateral 5. These system operation demands are shown in Table 7. IID measures system operational uses and at All-American Canal Station 2900 just upstream of Mesa Lateral 5 Heading. Total system operational use for 2020 was 167 KAF, including 10 KAF of LCWSP input, 39.8 KAF of seepage interception input, and 40 KAF of unaccounted canal water input.

Table 7. IID System Operations Consumptive Use within IID Water Service Area and from AAC at Mesa Lateral 5 to Imperial Dam, (KAF), 2020

Delivery System Evaporation	24.4
Canal Seepage	90.8
Canal Spill	10.1
Lateral Spill	121.5
Seepage Interception	-39.0
Unaccounted Canal Water	-40.0
Total System Operational Use, In valley	167.8
Imperial Dam to AAC @ Mesa Lat 5 (<i>Dam-Mesa Lat 5</i>)	9.2
LCWSP	-10
Total System Operational Use in 2020	167.0

Source: 2020 Water Balance rerun 01/25/2021

IID Interim Water Supply Policy for Non-Agricultural Projects (September 2009)

The IID IWSP provides a mechanism to address water supply requests for projects being developed within the IID service area. The IWSP designates up to 25,000 AFY of IID’s annual Colorado River water supply for new non-agricultural projects, provides a mechanism and process to develop a water supply agreement for any appropriately permitted project, and establishes a framework and set of fees to

ensure the supplies used to meet new demands do not adversely affect existing users by funding water conservation or augmentation projects as needed.⁹

Depending on the nature, complexity and water demands of the proposed project, new projects may be charged a one-time Reservation Fee and an annual Water Supply Development Fee for the contracted water volume used solely to assist in funding new water supply projects. The applicability of the fee to certain projects will be determined by IID on a case-by-case basis, depending on the proportion of types of land uses and water demand proposed for a project. The 2021 fee schedule is shown in Table 8.

Table 8. Interim Water Supply Policy 2021 Annual Non-Agricultural Water Supply Development Fee Schedule

Annual Demand (AF)	Reservation Fee (\$/AF)*	Development Fee (\$/AF)*
0-500	\$75.40	\$301.59
501-1000	\$106.16	\$424.64
1001-2500	\$133.30	\$533.22
2501-5000	\$164.67	\$658.68

Adjusted annually in accordance with the Consumer Price Index (CPI).

IID customers with new projects receiving water under the IWSP will be charged the appropriate water rate based on measured deliveries, see [IID Water Rate Schedules](#). As of January 2021, IID has issued one Water Supply Agreement for 1,200 AFY, leaving a balance of 23,800 AFY of supply available for contracting under the IWSP.

IID Temporary Land Conversion Following Policy (May 2012)

Imperial County planning officials determined that renewable energy facilities were consistent with the county’s agricultural zoning designation and began issuing CUPs for these projects with ten- to twenty-year terms. These longer-term, but temporary, land use designations were not conducive to a coordinated land use/water supply policy as envisioned in the Imperial IRWMP, because temporary water supply assignments during a conditional use permit (CUP) term were not sufficient to meet the water supply verification requirements for new project approvals. Agricultural land owners also sought long-term assurances from IID that, at project termination, irrigation service would be available for them to resume their farming operations.

Based on these conditions, IID determined it had to develop a water supply policy that conformed to the local land use decision-making in order to facilitate new development and economic diversity in Imperial County which has resulted in the IID Temporary Land Conversion Following Policy (TLCFP).¹⁰ IID concluded that certain lower water use projects could still provide benefits to local water users. The resulting benefits; however, may not be to the same categories of use (e.g., MCI) but to the district as a whole.

⁹ IID website: [Municipal, Industrial and Commercial Customers](#).

¹⁰ IID website: [Temporary Land Conversion Following Policy \(TLCFP\)](#), and The [TLCFP](#) are the sources of the text for this section.

At the general manager's direction, staff developed a framework for a fallowing program that could be used to supplement the IWSP and meet the multiple policy objectives envisioned for the coordinated land use/water supply strategy. Certain private projects that, if implemented, will temporarily remove land from agricultural production within the district's water service area include renewable solar energy and other non-agricultural projects. Such projects may need a short-term water supply for construction and decommissioning activities and longer-term water service for facility operation and maintenance or for treating to potable water standards. Conserved water will be credited to the extent that water use for the project is less than historic water use for the project site's footprint as determined by the ten year water use history.¹¹

Water demands for certain non-agricultural projects are typically less than that required for agricultural production; this reduced demand allows water to be made available for other users under IID's annual consumptive use cap. This allows the district to avail itself of the ability during the term of the QSA/Transfer Agreements under [CWC Section 1013](#) to create conserved water through projects such as temporary land fallowing conservation measures. This conserved water can then be used to satisfy the district's conserved water transfer obligation and for environmental mitigation purposes.

Under the terms of the legislation adopted to facilitate the QSA/Transfer Agreements and enacted in [CWC Section 1013](#), the [TLCFP](#) was adopted by the IID board on May 8, 2012 and revised on March 29, 2016 to update the fee schedule for 2016. This policy provides a framework for a temporary, long-term fallowing program to work in concert with the IWSP. While conserved water generated from the TLCFP is limited by law for use for water transfer or environmental purposes, by satisfying multiple district objectives the TLCFP serves to reduce efficiency conservation and water use reduction demands on IID water users, thus providing district wide benefits.

IMPERIAL IRRIGATION DISTRICT'S WATER RIGHTS

The laws and regulations that influence IID's water supply are noted in this section. The Law of the River (as described below), along with the 2003 Quantification Settlement Agreement and Related Agreements serve as the laws, regulations and agreements that primarily influence the findings of this WSA. These agreements grant California the most senior water rights along the Colorado River and IID specify that IID has access to 3.1 MAF per year. These two components will influence future decisions in terms of water supply during periods of shortages.

California Law

IID's has a longstanding right to divert Colorado River water, and IID holds legal titles to all of its water and water rights in trust for landowners within the district (CWC §20529 and §22437; *Bryant v. Yellen*,

¹¹ For details of how water conservation yield attributable to land removed from agricultural production and temporarily fallowed is computed, see [TLCFP for Water Conservation Yield](#).

447 U.S. 352, 371 (1980), fn.23.). Beginning in 1885, a number of individuals, as well as the California Development Company, made a series of appropriations of Colorado River water under California law for use in the Imperial Valley. The rights to these appropriations were among the properties acquired by IID from the California Development Company.

Law of the River

Colorado River water rights are governed by numerous compacts, state and federal laws, court decisions and decrees, contracts, and regulatory guidelines collectively known as the “Law of the River.” Together, these documents form the basis for allocation of the water, regulation of land use, and management of the Colorado River water supply among the seven basin states and Mexico.

Of all regulatory literature that governs Colorado River water rights, the following are the specifics that impact IID:

- Colorado River Compact (1922)
- Boulder Canyon Project Act (1928)
- California Seven-Party Agreement (1931)
- Arizona v. California US Supreme Court Decision (1964, 1979)
- Colorado River Basin Project Act (1968)
- Quantification Settlement Agreement and Related Agreements (2003)
- 2003 Colorado River Water Delivery Agreement: Federal QSA for purposes of Section 5(b) Interim Surplus Guidelines (CRWDA)
- 1970 Criteria for Coordinated Long-Range Operation of Colorado River Reservoirs
- Annual Operating Plan (AOP) for Colorado River Reservoirs
- 2007 Colorado River Interim Guidelines for Lower Basin Shortages and Coordinated Operations for Lakes Powell and Mead (2007 Interim Guidelines)

Colorado River Compact (1922)

With authorization of their legislatures and urging of the federal government, representatives from the seven Colorado River basin states began negotiations regarding distribution of water from the Colorado River in 1921. In November 1922, an interstate agreement called the “Colorado River Compact” was signed by the representatives giving the Lower Basin perpetual rights to annual apportionments of 7.5 million acre-feet (MAF) of Colorado River water (75 MAF over ten years). The Upper Basin was to receive the remainder, which based on the available hydrological record was also expected to be 7.5 MAF annually, with enough left over to provide 1.5 MAF annually to Mexico.

Boulder Canyon Project Act (1928)

Provisions in the 1928 Boulder Canyon Project Act made the compact effective and authorized construction of Hoover Dam and the All-American Canal, and served as the United States’ consent to accept the Compact. Through a Presidential Proclamation on June 25, 1929, this act resulted in

ratification of the Compact by six of the basin states and required California to limit its annual consumptive use to 4.4 MAF of the lower basin's apportionment plus not less than half of any excess or surplus water unapportioned by the Compact. A lawsuit was filed by the State of Arizona after its refusal to sign. Through the implementation of its 1929 Limitation Act, California abided by this federal mandate. The Boulder Canyon Act authorized the Secretary of the Interior (Secretary) to "contract for the storage of water... and for the delivery thereof... for irrigation and domestic uses," and additionally defined the lower basin's 7.5 MAF apportionment split, with an annual allocation 0.3 MAF to Nevada, 2.8 MAF to Arizona, and 4.4 MAF to California. Even though the three states never formally settled or agreed to these terms, a 1964 Supreme Court decision (*Arizona v. California*, 373 U.S. 546) declared the three states' consent to be insignificant since the Boulder Canyon Project Act was authorized by the Secretary.

California Seven-Party-Agreement (1931)

Following implementation of the Boulder Canyon Project Act, the Secretary requested that California make recommendations regarding distribution of its apportionment of Colorado River water. In August 1931, under chairmanship of the State Engineer, the California Seven-Party Agreement was developed and authorized by the affected parties to prioritize California water rights. The Secretary accepted this agreement and established these priorities through General Regulations issued in September of 1931. The first four (4) priority allocations account for California's annual apportionment of 4.4 MAF, with agricultural entities using 3.85 MAF of that total. Additional priorities are defined for years in which the Secretary declares that excess waters are available.

Arizona v. California U.S. Supreme Court Decision (1964, 1979)

The 1964 Supreme Court decision settled a 25-year disagreement between Arizona and California that stemmed from Arizona's desire to build the Central Arizona Project to enable use of its full apportionment. California's argument was that as Arizona used water from the Gila River, which is a Colorado River tributary, it was using a portion of its annual Colorado River apportionment. An additional argument from California was that it had developed a historical use of some of Arizona's apportionment, which, under the doctrine of prior appropriation, precluded Arizona from developing the project. California's arguments were rejected by the U.S. Supreme Court. Under direction of the Supreme Court, the Secretary was restricted from delivering water outside of the framework of apportionments defined by law. Preparation of annual reports documenting consumptive use of water in the three lower basin states was also mandated by the Supreme Court. In 1979, present perfected water rights (PPRs) referred to in the Colorado River Compact and in the Boulder Canyon Project Act were addressed by the Supreme Court in the form of a Supplemental Decree.

In March of 2006, a Consolidated Decree was issued by the Supreme Court to provide a single reference to the conditions of the original 1964 decrees and several additional decrees in 1966, 1979, 1984 and 2000 that stemmed from the original ruling. The Consolidated Decree also reflects the settlements of the federal reserved water rights claim for the Fort Yuma Indian Reservation.

Colorado River Basin Project Act (1968)

In 1968, various water development projects in both the upper and lower basins, including the Central Arizona Project (CAP) were authorized by Congress. Under the Colorado River Basin Project Act, priority was given to California's apportionment over (before) the CAP water supply in times of shortage. Also under the act, the Secretary was directed to prepare long-range criteria for the Colorado River reservoir system in consultation with the Colorado River Basin States.

Quantification Settlement Agreement and Related Agreements (2003)

With completion of a large portion of the CAP infrastructure in 1994, creation of the Arizona Water Banking Authority in 1995, and the growth of Las Vegas in the 1990s, California encountered increasing pressure to live within its rights under the Law of the River. After years of negotiating among Colorado River Compact States and affected California water delivery agencies, a Quantification Settlement Agreement and Related Agreements and documents were signed on October 10, 2003, by the Secretary of Interior, IID, Coachella Valley Water District (CVWD), Metropolitan Water District of Southern California (MWD), San Diego County Water Authority (SDCWA), and other affected parties.

The Quantification Settlement Agreement and Related Agreements (QSA/Transfer Agreements) are a set of interrelated contracts that resolve certain disputes among the United States, the State of California, IID, MWD, CVWD and SDCWA, for a period of 35 to 75 years, regarding the reasonable and beneficial use of Colorado River water; the ability to conserve, transfer and acquire conserved Colorado River water; the quantification and priority of Priorities 3(a) and 6(a)¹² within California for use of Colorado River water; and the obligation to implement and fund environmental impact mitigation.

Conserved water transfer agreements between IID and SDCWA, IID and CVWD, and IID and MWD are all part of the QSA/Transfer Agreements. For IID, these contracts identify conserved water volumes and establish transfer schedules along with price and payment terms. As specified in the agreements, IID will transfer nearly 415,000 AF annually over a 35-year period (or longer), as follows:

- to MWD 110,000 AF [modified to 105,000 AF in 2007],
- to SDCWA 200,000 AF,
- to CVWD and MWD combined 103,000 AF, and
- to certain San Luis Rey Indian Tribes 11,500 AFY of water.

All of the conserved water will ultimately come from IID system and on-farm efficiency conservation improvements. In the interim, IID has implemented a Following Program to generate water associated with Salton Sea mitigation related to the impacts of the IID/SDCWA water transfer, as required by the State Water Resources Control Board, which is to run from 2003 through 2017. In return for its QSA/Transfer Agreements programs and deliveries, IID will receive payments totaling billions of dollars

¹² Priorities 1, 2, 3(b), 6(b), and 7 of current Section 5 Contracts for the delivery of Colorado River water in the State of California and Indian and miscellaneous Present Perfected Rights within the State of California and other existing surplus water contracts are not affected by the QSA Agreement.

to fund needed efficiency conservation measures and to pay growers for conserved on-farm water, so IID can transfer nearly 14.5 MAF of water without impacting local productivity. In addition, IID will transfer to SDCWA 67,700 AFY annually of water conserved from the lining of the AAC in exchange for payment of lining project costs and a grant to IID of certain rights to use the conserved water. In addition to the 105,000 acre-feet of water currently being conserved under the 1988 IID/MWD Conservation Program, these more recent agreements define an additional 303,000 AFY to be conserved by IID from on-farm and distribution system conservation projects for transferred to SDCWA, CVWD, and MWD.

Colorado River Water Delivery Agreement (2003)¹³

As part of QSA/Transfer Agreements among California and federal agencies, the Colorado River Water Delivery Agreement: Federal QSA for purposes of Section 5(b) Interim Surplus Guidelines (CRWDA) was entered into by the Secretary of the Interior, IID, CVWD, MWD and SDCWA. This agreement involves the federal government because of the change in place of diversion from Imperial Dam into the All-American Canal to Parker Dam into MWD's Colorado River Aqueduct.

The CRWDA assists California to meet its "4.4 Plan" goals by quantifying deliveries for a specific number of years for certain Colorado River entitlements so transfers may occur. In particular, for the term of the CRWDA, quantification of Priority 3(a) was effected through caps on water deliveries to IID (consumptive use of 3.1 MAF per year) and CVWD (consumptive use of 330 KAF per year). In addition, California's Priority 3(a) apportionment between IID and CVWD, with provisions for transfer of supplies involving IID, CVWD, MWD and SDCWA are quantified in the CRWDA for a period of 35 years or 45 years (assumes SDCWA does not terminate in year 35) or 75 years (assumes SDCWA and IID mutually consent to renewal term of 30 years).

Allocations for consumptive use of Colorado River water by IID, CVWD and MWD that will enable California to stay within its basic annual apportionment (4.4 MAF plus not less than half of any declared surplus) are defined by the terms of the QSA/Transfer Agreements (**Table 9**). As specified in the QSA/Transfer Agreements, by 2026, IID annual use within (Imperial Valley) is to be reduced to just over 2.6 MAF of its 3.1 MAF quantified annual apportionment. The remaining nearly 500,000 AF (which includes the 67,000 AF from AAC lining) are to be transferred annually to urban water users outside of the Imperial Valley.

¹³ [CRWDA: Federal QSA](#) accessed 7 June 2017.

Table 9. CRWDA Annual 4.4 MAF Apportionment (Priorities 1 to 4) for California Agencies (AFY)

User	Apportionment (AFY)
Palo Verde Irrigation District and Yuma Project*	420,000
Imperial Irrigation District	3,100,000
Coachella Valley Water District	330,000
Metropolitan Water District of Southern California*	550,000
Total:	4,400,000

* PVID and Yuma Project did not agree to a cap; value represents a contractual obligation by MWD to assume responsibility for any overages or be credited with any volume below this value.

Notes: All values are consumptive use at point of Colorado River diversion: Palo Verde Diversion Dam (PVID), Imperial Dam (IID and CVWD), and Parker Dam (MWD). Source: IID Annual Water Report

Quantification of Priority 6(a) was effected through quantifying annual consumptive use amounts to be made available in order of priority to MWD (38 KAF), IID (63 KAF), and CVWD (119 KAF) with the provision that any additional water available to Priority 6(a) be delivered under IID’s and CVWD’s existing water delivery contract with the Secretary¹⁴ The CRWDA provides that the underlying water delivery contract with the Secretary remain in full force and effect. (*Colorado River Documents 2008*, Chapter 6, pages 6-12 and 6-13). The CRWDA also provides a source of water to effect a San Luis Rey Indian Water rights settlement. Additionally, the CRWDA satisfies the requirement of the 2001 Interim Surplus Guidelines (ISG) that a QSA be adopted as a prerequisite to the interim surplus determination by the Secretary in the ISG.

Inadvertent Overrun Payback Policy (2003)

The CRWDA Inadvertent Overrun Payback Policy (IOPP), adopted by the Secretary contemporaneously with the execution of the CRWDA, provides additional flexibility to Colorado River management and applies to entitlement holders in the Lower Division States (Arizona, California and Nevada)¹⁵ The IOPP defines inadvertent overruns as “Colorado River water diverted, pumped, or received by an entitlement holder of the Lower Division States that is in excess of the water users’ entitlement for the year.” An entitlement holder is allowed a maximum overrun of 10 percent (10%) of its Colorado River water entitlement.

In the event of an overrun, the IOPP provides a mechanism to payback the overrun. When the Secretary has declared a normal year for Colorado River diversions, a contractor has from one to three years to pay back its obligation, with a minimum annual payback equal to 20 percent of the entitlement holder’s maximum allowable cumulative overrun account or 33.3 percent of the total account balance, whichever is greater. However, when Lake Mead is below 1125 feet on January 1, the terms of the IOPP require that the payment of the inadvertent overrun obligation be made in the calendar year after the overrun is reported in the USBR Lower Colorado Region Colorado River Accounting and Water Use Report [for] Arizona, California, and Nevada (Decree Accounting Report).¹⁶

¹⁴ When water levels in the Colorado River reservoirs are low, Priority 5, 6 and 7 apportionments are not available for diversion.

¹⁵ USBR, 2003 CRWDA ROD Implementation Agreement, IOPP and Related Federal Actions Final EIS. Section IX. Implementing the Decision A. Inadvertent Overrun and Payback Policy. Pages 16-19 of 34.

¹⁶ 2003 [CRWDA ROD](#). Section IX. A.6.c., page 18 of 34.

1970 Criteria for Coordinated Long-Range Operation of Colorado River Reservoirs

The 1970 Operating Criteria control operation of the Colorado River reservoirs in compliance with requirements set forth in the Colorado River Compact of 1922, the United States-Mexico Water Treaty of 1944, the Colorado River Storage Project Act of 1956, the Boulder Canyon Projects Act (Lake Mead) and the Colorado River Basin Project Act (Upper Basin Reservoirs) of 1968, and other applicable federal laws. Under these Operating Criteria, the Secretary makes annual determinations published in the USBR Annual Operating Plan for Colorado River Reservoirs (discussed below) regarding the release of Colorado River water for deliveries to the lower basin states. A requirement to equalize active storage between Lake Powell and Lake Mead when there is sufficient storage in the Upper Basin is included in these operating criteria. **Figure 5** identifies the major storage facilities at the upper and lower basin boundaries.

Annual Operating Plan for Colorado River Reservoirs (Applicable Only if Lake Mead Surplus/Shortage)

The AOP is developed in accordance with Section 602 of the Colorado River Basin Project Act (Public Law 90-537); the Criteria for Coordinated Long-Range Operations of Colorado River Reservoirs Pursuant to the Colorado River Basin Project Act of 1968, as amended, promulgated by the Secretary of the Interior; and Section 1804(c)(3) of the Grand Canyon Protection Act (Public Law 102-575). As part of the AOP process, the Secretary makes determinations regarding the availability of Colorado River water for deliveries to the lower basin states, including whether normal, surplus, and shortage conditions are in effect on the lower portion of the Colorado River.

2007 Colorado River Interim Guidelines for Lower Basin Shortages (2007 Interim Guidelines)

A multi-year drought in the Colorado River Upper Basin triggered the need for the 2007 Interim Shortage Guidelines. In the summer of 1999, Lake Powell was essentially full of reservoir storage at 97 percent of capacity. However, precipitation fell off starting in October 1999 and 2002 inflow was the lowest recorded since Lake Powell began filling in 1963.¹⁷ By August 2011, inflow was 279 percent (279%) of average; however, drought resumed in 2012 and continued through calendar year 2020. Using the record in **Table 10**, average unregulated inflow to Lake Powell for water years 2000-2020 is 75.47 percent (75.5%); or if 2011 is excluded, 72.45 percent (72.5%) of the historic average.

Table 10. Unregulated Inflow to Lake Powell, Percent of Historic Average, 2000-2019

2000	2001	2002	2003	2004	2005	2006	2007	2008	2009	2010
62%	59%	25%	51%	49%	105%	73%	68%	102%	88%	73%
2011	2012	2013	2014	2015	2016	2017	2018	2019	2020	
136%	35%	49%	90%	83%	80%	100%	36%	110%	110%	

Source: [UCR Water Operations: Historic Data \(2000-2020\)](#)

¹⁷ Water Year: October 1 through September 30 of following year, so water year ending September 30, 1999

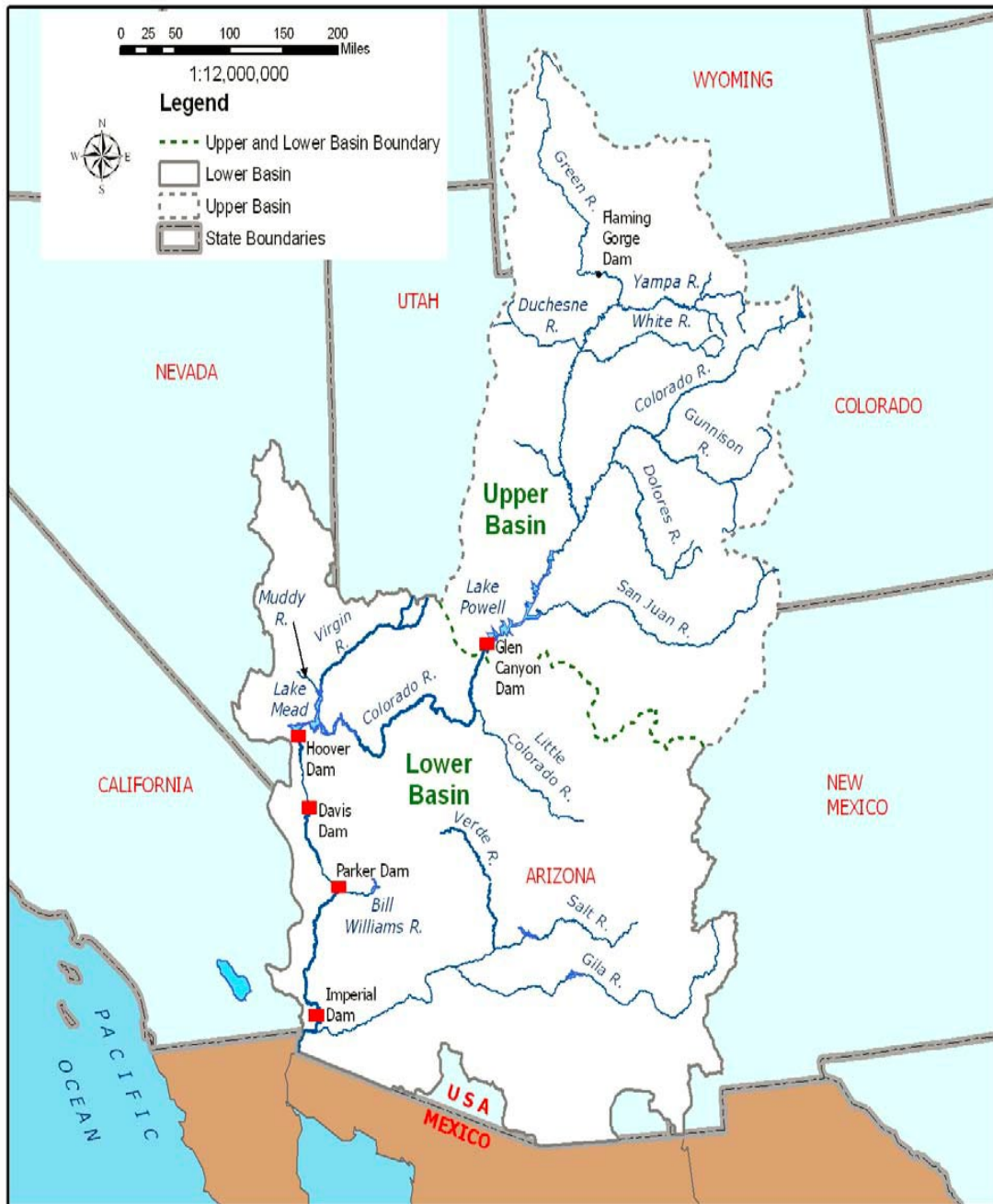


Figure 5. Major Colorado River Reservoir Storage Facilities and Basin Location Map

Source: [Final EIS – Colorado River Interim Guidelines for Lower Basin Shortages and Coordinated Operations for Lake Powell and Lake Mead, Volume 1 Chapter 1 Purpose and Need](#) , p I-10.

In the midst of the drought period, USBR developed 2007 Interim Guidelines with consensus from the seven basin states, which selected the Draft EIS Preferred Alternative as the basis for USBR’s final

determination. The basin states found the Preferred Alternative best met all aspects of the purpose and need for the federal action.¹⁸

The 2007 Interim Guidelines Preferred Alternative highlights the following:

1. The need for the Interim Guidelines to remain in place for an extended period of time.
2. The desirability of the Preferred Alternative based on the facilitated consensus recommendation from the basin states.
3. The likely durability of the mechanisms adopted in the Preferred Alternative in light of the extraordinary efforts that the basin states and water users have undertaken to develop implementing agreements that will facilitate the water management tools (shortage sharing, forbearance, and conservation efforts) identified in the Preferred Alternative
4. That the range of elements in the Preferred Alternative will enhance the Secretary's ability to manage the Colorado River reservoirs in a manner that recognizes the inherent tradeoffs between water delivery and water storage.

In June 2007, USBR announced that a preferred alternative for Colorado River Interim Guidelines for Lower Basin Shortages and Coordinated Operations of Lake Powell and Lake Mead (Final Preferred Alternative) had been determined. The Final Preferred Alternative, based on the basin states' consensus alternative and an alternative submitted by the environmental interests called "Conservation Before Shortage," is comprised of four key operational elements which are to guide operations of Lake Powell and Lake Mead through 2026 are:

1. Shortage strategy for Lake Mead and Lower Division states: The Preferred Alternative proposed discrete levels of shortage volumes associated with Lake Mead elevations to conserve reservoir storage and provide water users and managers in the Lower Basin with greater certainty to know when, and by how much, water deliveries will be reduced during low reservoir conditions.
2. Coordinated operations of Lake Powell and Lake Mead: The Preferred Alternative proposed a fully coordinated operation of the reservoirs to minimize shortages in the Lower Basin and to avoid risk of curtailments of water use in the Upper Basin.
3. Mechanism for storage and delivery of conserved water in Lake Mead: The Preferred Alternative proposed the Intentionally Created Surplus (ICS) mechanism to provide for the creation, accounting, and delivery of conserved system and non-system water thereby promoting water conservation in the Lower Basin. Credits for Colorado River or non-Colorado River water that has been conserved by users in the Lower Basin creating an ICS would be made available for release from Lake Mead at a later time. The total amount of credits would be 2.1 MAF, but this amount could be increased up to 4.2 MAF in future years.

¹⁸ USBR *Colorado River Interim Guidelines for Lower Basin Shortages and Coordinated Operations for Lake Powell and Lake Mead* <<http://www.usbr.gov/lc/region/programs/strategies.html>>

4. Modifying and extending elements of the Interim Surplus Guidelines (ISG). The ISG determines conditions under which surplus water is made available for use within the Lower Division states. These modifications eliminate the most liberal surplus conditions thereby leaving more water in storage to reduce the severity of future shortages.

With respect to the various interests, positions and views of the seven basin states, this provision adds an important element to the evolution of the legal framework for prudent management of the Colorado River. Furthermore, the coordinated operation element allows for adjustment of Lake Powell releases to respond to low reservoir storage conditions in either Lake Powell or Lake Mead.¹⁹ States found the Preferred Alternative best met all aspects of the purpose and need for the federal action.²⁰ The 2007 Interim Guidelines are in place from 2008 through December 31, 2025 (through preparation of the 2026 Annual Operating Plan).

Lower Colorado Region Water Shortage Operations

The drought in the Colorado River watershed has continued through 2020 despite an increase in observed runoff in August 2011 when unregulated inflow to Lake Powell was 279 percent of the average. Since 2000, Lake Mead has been below the “average” level of lake elevations (see [Figure 6](#)). Such conditions have caused the preparation of shortage plans for waters users in Arizona and Nevada, and in Mexico.

¹⁹ For a discussion of the 2007 Interim Guidelines, see: [Intermountain West Climate Summary](#) by The Western Water Assessment, issued Jan. 21, 2008, Vol. 5, Issue 1, January 2009 Climate Summary, Feature Article, pages 5-7, 22 Mar 2013.

²⁰ [USBR Colorado River Interim Guidelines for Lower Basin Shortages and Coordinated Operations for Lake Powell and Lake Mead](#).

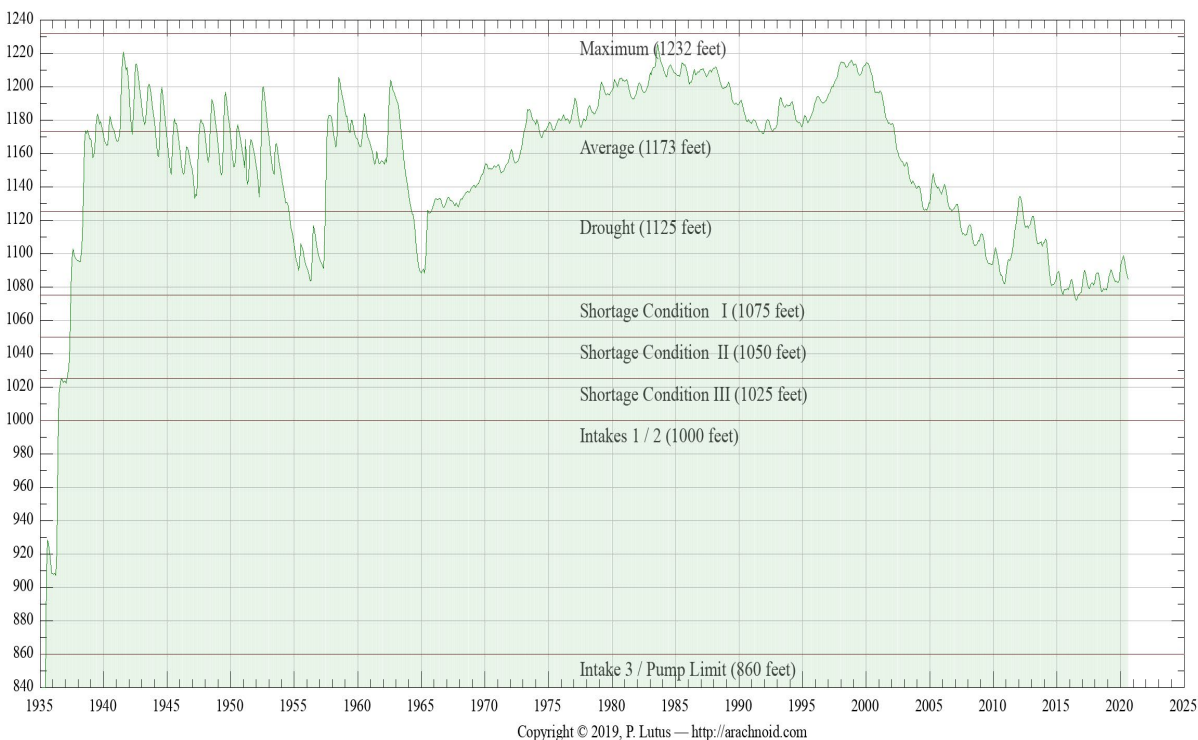


Figure 6. Lake Mead Water Elevation Levels 2020 visit <http://www.arachnoid.com/NaturalResources/index.html>

According to guidelines put in place in 2007, Arizona and Nevada begin to take shortages when the water elevation in Lake Mead falls below 1,075 feet. The volumes of shortages increase as water levels fall to 1,050 feet and again at 1,025 feet. In 2012, Mexico agreed to participate in a 5-year pilot agreement to share specific volumes of shortages at the same elevations. The 2007 interim shortage guidelines contain no reductions for California, which has senior water rights to the Central Arizona Project water supply, through 2025 when the guidelines expire. If Lake Mead's elevation drops to 1,025 feet, a re-consultation process would be triggered among the basin states to address next steps. Consultation would start out within each state, then move to the three lower basin states, followed by all seven states and the USBR. Mexico will then be brought into the process unless they choose to participate earlier.

IMPERIAL IRRIGATION DISTRICT WATER SUPPLY AND DEMAND

SB 610 requires an analysis of a normal, single dry, and multiple dry water years to show that adequate water is available for the proposed Project in various climate scenarios. Water availability for this Project in a normal year is no different from water availability during a single-dry and multiple-dry year scenarios. This is due to the small effect rainfall has on water availability in IID's arid environment along with IID's strong entitlements to the Colorado River water supply. Local rainfall does have some impact on how much water is consumed (i.e. if rain falls on agricultural lands, those lands will not demand as

much irrigation), but does not impact the definition of a normal year, a single-dry year or a multiple-dry year scenario.

Water Availability – Normal Year

IID is entitled to annual net consumptive use of 3.1 MAF of Colorado River, less its QSA/Transfer Agreement obligations. Imperial Dam, located north of Yuma, Arizona, serves as a diversion structure for water deliveries throughout southeastern California, Arizona and Mexico. Water is transported to the IID water service area through the AAC for use throughout the Imperial Valley. IID historic and forecast net consumptive use volumes at Imperial Dam from CRWDA Exhibit B are shown in Table 11. Volumes 2003-2020 are adjusted for USBR Decree Accounting historic records. Volumes for 2021-2077 are from CRWDA Exhibit B modified to reflect 2014 Letter Agreement changes to the 1988 IID/MWD Water Conservation Agreement.²¹

Table 11. IID Historic and Forecast Net Consumptive Use for Normal Year, Single-Dry Year and Multiple-Dry Year Water Supply, 2003-2037, et seq. (CRWDA Exhibit B)

IID Quantification and Transfers, Volumes in KAF at Imperial Dam ¹										
Col 1	2	3	4	5	6	7	8	9	10	11
Year	IID Priority 3(a)									IID Net [Available for] Consumptive Use (Col 2 - 10)
	IID 3(a) Quantified Amount	IID Reductions							IID Total Reduction (Σ Cols 3-9) ⁵	
		1988 MWD Transfer ²	SDCWA Transfer	AAC Lining	Salton Sea Mitigation SDCWA Transfer ³	Intra- Priority 3 CVWD Transfer	MWD Transfer w\ Salton Sea Restoration ⁴	Misc. PPRs		
2003	3,100	105.1	10.0	0.0	0.0	0.0	0.0	11.5	126.6	2978.2
2004	3,100	101.9	20.0	0.0	15.0	0.0	0.0	11.5	148.4	2743.9
2005	3,100	101.9	30.0	0.0	15.0	0.0	0.0	11.5	158.4	2756.8
2006	3,100	101.2	40.0	0.0	20.0	0.0	0.0	11.5	172.7	2909.7
2007	3,100	105.0	50.0	0.0	25.0	0.0	0.0	11.5	191.5	2872.8
2008	3,100	105.0	50.0	8.9	26.0	4.0	0.0	11.5	205.4	2825.1
2009	3,100	105.0	60.0	65.5	30.1	8.0	0.0	11.5	280.1	2566.7
2010	3,100	105.0	70.0	67.7	33.8	12.0	0.0	11.5	294.8	2540.5
2011	3,100	103.9	63.3	67.7	0.0	16.0	0.0	11.5	262.4	2915.8
2012	3,100	104.1	106.7	67.7	15.2	21.0	0.0	11.5	326.2	2,903.2
2013	3,100	105.0	100.0	67.7	71.4	26.0	0.0	11.5	381.6	2,554.9
2014	3,100	104.1	100.0	67.7	89.2	31.0	0.0	11.5	403.5	2,533.4
2015	3,100	107.82	100.0	67.7	153.3	36.0	0.0	11.5	476.3	2,480.9
2016	3,100	105.0	100.0	67.7	130.8	41.0	0.0	11.5	456.0	2,504.3
2017	3,100	105.0	100.0	67.7	105.3	45.0	0.0	9.9	434.5	2,548.2
2018	3,100	105	130	67.7	0.1	63	0.0	11.5	377.3	2,722.8
2019 ⁶	3,100	105	160	67.7	46.55	68	0.0	11.5	458.75	2,687.8

²¹ [2014 Imperial Irrigation District Letter Agreement](#) for Substitution and Conservation Modifications to the IID/MWD Water Conservation Agreement - December 17, 2014.

IID Quantification and Transfers, Volumes in KAF at Imperial Dam ¹										
Col 1	2	3	4	5	6	7	8	9	10	11
Year	IID Priority 3(a)								IID Total Reduction (Σ Cols 3-9) ⁵	IID Net [Available for] Consumptive Use (Col 2 - 10)
	IID 3(a) Quantified Amount	IID Reductions								
		1988 MWD Transfer ²	SDCWA Transfer	AAC Lining	Salton Sea Mitigation SDCWA Transfer ³	Intra-Priority 3 CVWD Transfer	MWD Transfer w\ Salton Sea Restoration ⁴	Misc. PPRs		
2020	3,100	105	192.5	67.7	0.0	73	0.0	9.8	448.0	2,652.0
2021	3,100	105	205	67.7	0	78	0.0	11.5	467.2	2,632.8
2022	3,100	105	203	67.7	0	83	0.0	11.5	470.2	2,629.8
2023	3,100	105	200	67.7	0	88	0.0	11.5	472.2	2,627.8
2024	3,100	105	200	67.7	0	93	0.0	11.5	477.2	2,622.8
2025	3,100	105	200	67.7	0	98	0.0	11.5	482.2	2,617.8
2026	3,100	105	200	67.7	0	103	0.0	11.5	487.2	2,612.8
2027	3,100	105	200	67.7	0	103	0.0	11.5	487.2	2,612.8
2028	3,100	105	200	67.7	0	103	0.0	11.5	487.2	2,612.8
2029-37	3,100	105	200	67.7	0	103	0.0	11.5	487.2	2,612.8
2038-47 ⁷	3,100	105	200	67.7	0	103	0.0	11.5	487.2	2,612.8
2048-77 ⁸	3,100	105	200	67.7	0	50	0.0	11.5	434.2	2,665.8

1. 2003 through 2020, volumes are adjusted for actual USBR Decree Accounting values; IID Total Reduction and Net Available for Consumptive Use may not equal Col 2 minus Col 10, if IID conservation/use was not included in Exhibit B.
2. 2014 Letter of Agreement provides that, effective January 2016 total amount of conserved water available is 105 KAFY
3. Salton Sea Mitigation volumes may vary based on conservation volumes and method of conservation.
4. This transfer is not likely given lack of progress on Salton Sea restoration as of 2018; shaded entries represents volumes that may vary..
5. Reductions include conservation for 1988 IID/MWD Transfer, IID/SDCWA Transfer, AAC Lining; SDCWA Transfer Mitigation, MWD Transfer w/Salton Sea Restoration (if any); Misc. PPRs. Amounts are independent of increases and reductions as allowed by the IOPP.
6. In order to resolve the outstanding 2010 Salton Sea mitigation water pre-delivery issue, IID left 46,546 AF of extraordinary conservation in Lake Mead. See IID's December 19, 2019 revised 2019 water order and Reclamation's March 10, 2020 approval letter.
7. Assumes SDCWA does not elect termination in year 35.
8. Assumes SDCWA and IID mutually consent to renewal term of 30 years.
9. Modified from 100 KAFY in CRWDA Exhibit B; stating in 2018 MWD will provide CVWD 50 KAFY of the 100 KAFY.

Source: [CRWDA: Federal QSA](#) Exhibit B, p 13; updated values from [2019 QSA Implementation Report](#)

Due to limits on annual consumptive use of Colorado River water under the QSA/Transfer Agreements, IID's water supply during a normal year is best represented by the CRWDA Exhibit B Net Available for Consumptive Use (Table 11 , Column 11). The annual volume is IID Priority 3(a) Quantified Amount of 3.1 million acre-feet (MAF) (Table 11 , Column 2) less the IID transfer program reductions for each year (Table 11, Columns 3-9). IID suggests Table 11, which assumes full use of IID's quantified water supply, be used in determining base normal year water availability.

CRWDA Exhibit B Net Available for Consumptive Use volumes less system operation demand represents the amount of water available for delivery by IID Water Department to its customers each year. In a normal year, perhaps 50,000 to 100,000 AF of effective rainfall would fall in the IID water service area. However, rainfall is not evenly distributed throughout the IID water service area and is not taken into account by IID in the submittal of its Estimate of Diversion (annual water order) to the USBR.

Expected Water Availability – Single Dry and Multiple Dry Years

When drought conditions exist within the IID water service area, as has been the case for the past decade or so, the water supply available to meet agricultural and non-agricultural water demands remains the same as normal year water supply because IID continues to rely solely on its entitlement for Colorado River water. Due to the priority of IID water rights and other agreements, drought conditions affecting Colorado River water supplies cause shortages for Arizona, Nevada and Mexico, before impacting California and IID. Accordingly, the Net Available for Consumptive Use volumes in Table 11, Column 11 represents the water supply at Imperial Dam available for diversion by IID in single-dry year and multiple-dry year scenarios.

Under CRWDA Inadvertent Overrun Payback Policy (IOPP), IID has some flexibility to manage its water use. When the water level in Lake Mead is above 1,125 feet, an overrun of its USBR approved annual water order is permissible, and IID has up to three years to pay water use above the annual water order. When Lake Mead’s water level is at or below 1,125 feet on January 1 in the calendar year after the overrun is reported in the USBR Lower Colorado Region Decree Accounting Report, the IOPP prohibits additional overruns and requires that outstanding overruns be paid back in the subsequent calendar year rather than in three years as allowed under normal conditions; that is, the payback is to be made in the calendar year following publication of the overrun in the USBR Decree Accounting Report. For historic IID annual rainfall, net consumptive use, transfers and IID underrun/overrun amounts, see Table 12. For purposes of this WSA, years with a shortage condition that impacts non-agricultural projects such as an IOPP payback obligation constitute “dry” years for IID.

In years of inadvertent overrun payback, conditions such as those in Sections 3.7 and 3.8 of the 2012 IWSP Water Agreement may go into effect, with the result that less water would be available for non-agricultural development contractors. Under such conditions, IID has requested that Vega SES 4, LLC management work with IID to ensure it can manage the reduction. IID has further indicated that, provided a water supply agreement is approved and executed by IID under the provisions of the IWSP, IID will have sufficient water to support the water of this Project.

Table 12. IID Annual Rainfall (In), Net Consumptive Use and Underrun/Overrun Amounts (AF), 1988-2020

Year	IID Total Annual Rainfall	IID Water Users	IID/MWD Transfer	IID/ SDCWA Transfer	SDCWA Transfer Salton Sea Mitigation	IID Underrun /<Overrun>	IID/CVWD Transfer	AAC Lining
1988		2,947,581						
1989		3,009,451						
1990	91,104	3,054,188	6,110					
1991	192,671	2,898,963	26,700					
1992	375,955	2,575,659	33,929					
1993	288,081	2,772,148	54,830					
1994	137,226	3,048,076	72,870					
1995	159,189	3,070,582	74,570					

Year	IID Total Annual Rainfall	IID Water Users	IID/MWD Transfer	IID/ SDCWA Transfer	SDCWA Transfer Salton Sea Mitigation	IID Underrun /<Ovrrun>	IID/CVWD Transfer	AAC Lining
1996	78,507	3,159,609	90,880					
1997	64,407	3,158,486	97,740					
1998	100,092	3,101,548	107,160					
1999	67,854	3,088,980	108,500					
2000	29,642	3,112,770	109,460					
2001	12,850	3,089,911	106,880					
2002	12,850	3,152,984	104,940					
2003	116,232	2,978,223	105,130	10,000	0	<6,555>		
2004	199,358	2,743,909	101,900	20,000	15,000	-166,408		
2005	202,983	2,756,846	101,940	30,000	15,000	-159,881		
2006	19,893	2,909,680	101,160	40,000	20,000	<12,414>		
2007	64,580	2,872,754	105,000	50,000	25,021	<6,358>		
2008	63,124	2,825,116	105,000	50,000	26,085	-47,999	4,000	8,898
2009	30,0354	2,566,713	105,000	60,000	30,158	-237,767	8,000	65,577
2010	189,566	2,545,593	105,000	70,000	33,736	-207,925	12,000	67,700
2011	109,703	2,915,784	103,940	63,278	0	<82,662>	16,000	67,700
2012	133,526	2,903,216	104,140	106,722	15,182	<134,076>	21,000	67,700
2013	134,497	2,554,845	105,000	100,000	71,398	-64,981	26,000	67,700
2014	53,517	2,533,414	104,100	100,000	89,168	-797	31,000	67,700
2015	97,039	2,480,933	107,820	100,000	153,327	-90,025	36,000	67,700
2016	90,586	2,504,258	105,000	100,000	130,796	-62,497	41,000	67,700
2017	105,919	2,548,171	105,000	100,000	105,311	-30,591	45,000	67,700
2018	63,318	2,625,422	105,000	130,000	0	0	63,000	67,700
2019	146,384	2,558,136	105,000	160,000	46,555	-34,215	68,000	67,700
2020	129,693	2,493,661	105,000	192,500	0	-95,715	73,000	67,700

Notes: Volumes in acre-feet and except Total Annual Rainfall are USBR Decree Accounting Report record at Imperial Dam.

IID Total Annual Rainfall from IID Provisional Water Balance, first available calculations are for 1990

Not all IID QSA programs are shown on this table.

Source: USBR Decree Accounting reports, except IID Total Rainfall and IID Overrun/Underrun is a separate calculation

Source: 2019 IID QSA Implementation Report and 2020 IID SWRCB Report, page 31 of 335; IID Total Rainfall and IID Overrun/Underrun is a separate calculation

Equitable Distribution Plan (EDP)

A 2006 study by Hanemann and Brookes suggested that overrun conditions were likely to occur 40-50% of the years during the decade following the report. On November 28, 2006, the IID Board of Directors adopted Resolution No 22-2006 approving development and implementation of an Equitable Distribution Plan to deal with times when customers’ demand would exceed IID’s Colorado River supply. The EDP, adopted in 2007 allowed the IID Board to institute an apportionment program. As part

of this resolution, the IID Board directed the General Manager to prepare the rules and regulations necessary or appropriate to implement the plan within the district. The 2009 Regulations for EDP were created to enable IID to implement a water management tool (apportionment) to address years in which water demand is expected to exceed supply. So far, for the 17 years from 2003 through 2020, demand has exceeded supply by some amount for a total of five years (see Table 12). IID has not experienced any overruns since 2012.

The IID 2013 Revised EDP, adopted by the Board on October 28, 2013, further allowed IID to pay back its outstanding overruns using an EDP Apportionment, and it was expected that an annual EDP Apportionment would be established for each of the next several years, if not for the duration of the QSA/Transfer Agreements. For purposes of this WSA, years with a shortage condition that impacts non-agricultural projects such as an IOPP payback obligation constitute “dry” years for IID. For single-dry year and multiple-dry water year assessments, IID’s EDP shall govern. IOPP payback, EDP Apportionment, and the IWSP are further discussed under single-dry and multiple-dry year projections. However, the implementation of the EDP apportionment was legally challenged, and on February 6, 2018, the IID board approved a resolution repealing the EDP until the issue is resolved. As of the date of this WSA, a resolution had been reached, but a modified EDP has yet to be re-instated.

Water Management under Inadvertent Overrun Payback Policy (IOPP)

On January 1, 2013, the water level in Lake Mead was 1120.5 feet and for the first time since the IOPP came into effect, Lower Colorado River Basin water users faced a shortage condition (Figure 7). For IID, this meant that outstanding overruns must be paid back to the river in calendar years 2013 and 2014 as described below and shown in Table 13.

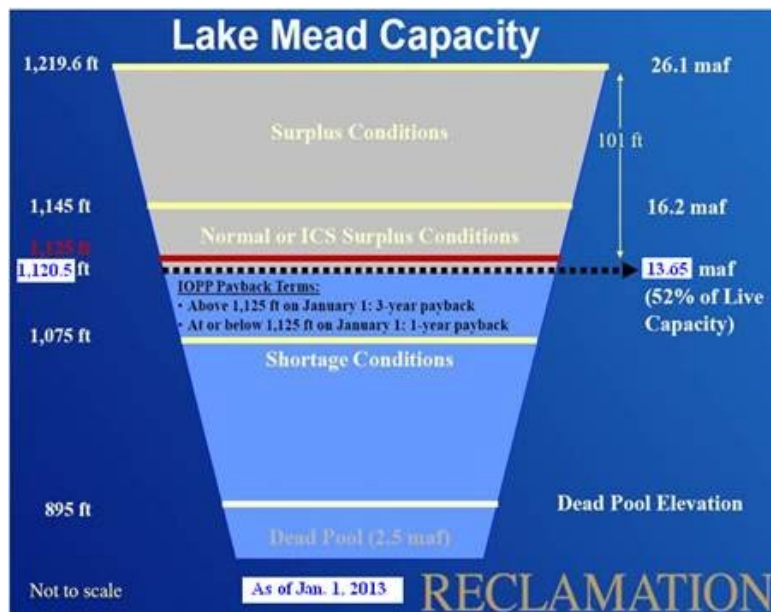


Figure 7. Lake Mead IOPP Schematic

IID’s maximum allowable cumulative overrun account is 62,000 AF.²² Thus, for IID’s 2011 overrun of 82,662 AF (which was published in 2012), 62,000 AF were to be paid back at the river in calendar year 2013, with the remaining 20,662 AF to be paid back in 2014; however, due to an early payback of 6,290 AF in 2012, IID had 55,710 AF to pay back in 2013 and 20,662 AF of the 2011 overrun to pay back in 2014. In addition, because of the low level of Lake Mead on Jan 1, 2013, IID’s entire 2012 overrun of 134,076 AF must be paid back in 2014, for a total of 154,738 AF in 2014. Furthermore, under the terms of the IOPP, no overruns are allowed in a year when payback is required. IID has not experienced any overrun pay back since 2014.

Table 13. IID Inadvertent Overrun Payback to the Colorado River under the IOPP, 2012-2020

Calendar Year of Payback	2011 Overrun Payback (AF)	2012 Overrun Payback (AF)	Payback Total for Calendar Year (AF)
2013	55,710	-	55,710
2014	20,662	134,076	154,738
Total Payback	76,372	134,076	210,448

Notes: All values are consumptive use volumes at Imperial Dam (AF).
 2013 Payback Total was 62 KAF, but in 2012 IID had 6,290 AF of early payback, reducing volume to 55,710 AF

The 2013 IOPP payback obligation and prohibition on overruns in payback years, led the IID Board to implement an apportionment program pursuant to the 2009 Regulations for EDP, which were subsequently revised and modified. The Revised 2013 EDP was a version approved and adopted by the IID Board on October 28, 2013 (see Attachment B). The Revised 2013 EDP also establishes an agriculture water clearinghouse to facilitate the movement of apportioned water between agricultural water users and between farm units. This is to allow growers and IID to balance water demands for different types of crops and soils with the apportionment s that are made. IID’s Water Conservation Committee agreed on a July 1, 2013 start date for the agricultural water clearinghouse

Generally, the EDP Apportionment is not expected to impact industrial use. However, given the possibility of continuing drought on the Colorado River and other stressors, provisions such as the 2012 IWSP Water Agreement sections 3.7 and 3.8 as well for dry and multiple dry year water assessment may come into effect. However, IID has agreed to work with Project proponents to ensure to the extent possible that the IWSP Water Agreement terms will not negatively impact Project operation.

Project Water Availability for a 20-Year Period to Meet Projected Demands

The proposed Project will obtain drinking water from a certified State of California provider. Approximately 275 AF of untreated canal water will be used during the 18-month construction period for dust control and soil conditioning. During operations, up to 10 AFY of untreated canal water will be used for washing of the solar PV modules, as needed. Bottled water will be provided for potable needs during construction. Water for employee sanitation will be provided by temporary, portable facilities (toilets and hand wash stations). There will be no potable water connection to the facility.

²² For IID Quantified Amount: 3.1 MAFY *10 percent = 310,000 AF allowable cumulative overrun account amount; minimum repayment in a calendar year is the less of 310,000 * 20 percent = 62,000 or the amount in the account, if less than 62,000 AF.

Untreated Colorado River water will be supplied to the project via the adjacent All American Canal under an IWSP Water Supply Agreement with IID. The Project site is currently open land and does not receive water from IID. Thus, the proposed Project water demand would be a new use within the District service area.

As noted previously, under the terms of California legislation adopted to facilitate the QSA/Transfer Agreements and enacted in [CWC Section 1013](#), the IID board adopted the [TLCFP](#) to address how to deal with any such temporary reduction of water use by projects like such as solar projects that are developed under a CUP.

While conserved water generated from the TLCFP is limited by law for use for water transfer or environmental purposes, by satisfying multiple district objectives the TLCFP serves to reduce the need for efficiency conservation and other water use reduction practices on the part of IID and its water users providing the district with wide benefits. One of the considerations in developing the TLCFP was to provide agricultural land owners with long-term assurances from IID that, at Project termination, irrigation service would be available for them to resume farming operations.

IWSP Water

At the present time, IID is providing water for use by solar energy generation projects under Water Rate [Schedule 7 General Industrial Use](#). If IID determines that the proposed Project should obtain water under IID's Interim Water Supply Policy (IWSP) for non-agricultural projects rather than [Schedule 7 General Industrial Use](#), the Applicant will do so. IID will determine whether the Project should obtain water under IID's Interim Water Supply Policy (IWSP) for non-agricultural projects in addition to Schedule 7 General Industrial Water.

The IWSP, provided herein as Attachment A, designates up to 25,000 AFY of water for potential Non-Agricultural Projects within IID's water service area. As of January 2021, IID has 23,800 AF available under the IWSP for new projects such as the proposed project. The IWSP establishes a schedule for Processing Fees, Reservation Fees, and Connection Fees that change each year for all non-agricultural projects, and annual Water Supply Development fees for some non-agricultural projects. The proposed Project's water use will be subject to the annual Water Supply Development fee if IID determines that water for the Project is to be supplied under the IWSP.

The likelihood that IID will not receive its annual 3.1 MAF apportionment less QSA/Transfer Agreement obligations of Colorado River water is low due to the high priority of the IID entitlement relative to other Colorado River contractors, see IID's Water Rights section on [page 22](#). If such reductions were to come into effect within the 20-year Project life, the Applicants are to work with IID to ensure any reduction can be managed.

As such, lower Colorado River water shortage does not present a material risk to the available water supply that would prevent the County from making the findings necessary to approve this WSA. IID, like any water provider, has jurisdiction to manage the water supply within its service area and impose

conservation measures during a period of temporary water shortage. Furthermore, without the proposed Project, IID’s task of managing water supply under the QSA/Transfer Agreements would be more difficult, because agricultural use on the proposed Project site would be significantly higher than the proposed demand for the proposed Project as explained in the Expected Water Demands for the Proposed Project on the section that follows.

Water for construction (primarily for dust control) would be obtained from IID canals or laterals in conformance with IID rules and regulations for MCI temporary water use.²³ Water would be picked up from a nearby canal or lateral and delivered to the construction location by a water truck capable of carrying approximately 4,000 gallons per load. To obtain water delivery service, the Project proponent will complete an [IID-410 Certificate of Ownership and Authorization](#) (Water Card), which allows the Water Department to provide the district with information needed to manage the district apportioned supply. Water cards are used for Agriculture, Municipal, Industrial and Service Pipe accounts. If water is to be provided under IWSP in addition to Schedule 7. General Industrial Use, the Applicant will seek to enter into a IWSP Water Supply Agreement.

Expected Water Demands for the Proposed Project

Water for the Project will be needed on-site for dust control and soil condition during the 18-month construction period and for PV module washing during the 30-year operational phase (see Table 14). Untreated Colorado River water will be supplied to the project via the adjacent All American Canal under an IWSP Water Supply Agreement with IID. The Project site is currently open land and does not receive water from IID. Thus, the proposed Project water demand would be a new use within the District service area.

Project raw water uses are summarized in in Table 14.

Table 14. Project Water Uses (AFY)

Use	Acre-Feet per Year
Raw Water for construction (275 AF total over 18 months = 183.3 AFY)	183.3
Raw Water for PV module washing	10
TOTAL RAW WATER USAGE (long term)	10

IID currently does not deliver untreated Colorado River water to the proposed Project site for agricultural uses.

The proposed Project has an estimated total water demand of 460 AF or 23 AFY amortized over a 20-year term (to be pumped to water trucks directly from the All American Canal – there would be no diversion through any delivery gates for Project). Thus, the proposed Project demand is an increase of

²³ Complete the Application for Temporary Water Use and submit to Division office. Complete encroachment permit through Real Estate – non-refundable application fee of \$250, se. IID website: [Real Estate / Encroachments, Permissions, and Other Permitting](#). Fee for temporary service water: Schedule No. 7 General Industrial Use / Temporary Service Minimum charge for up to 5 AF, pay full flat fee for 5 AF at General Industrial Use rate (\$425); use more than 5 AF, pay fee for actual use at General Industrial Rate (\$85/AF).

23 AFY from the historical 10-year average. There has been no prior delivery for agricultural uses at the proposed Project site. The proposed Project’s estimated water demand of 23 AFY amortized over 20 years represents only 0.1 percent (0.1%) of the 23,800 AYF balance of supply available for contracting under the IWSP.

IID’s Ability to Meet Demands With Water Supply

Non-agricultural water demands for the IID water service area are projected for 2025-2055 in Table 5, and IID agricultural demands including system operation are projected for 2025-2055 in Table 6, all volumes within the IID water service area. IID water supplies available for consumptive use after accounting for mandatory transfers are projected to 2077 in Table 11 (Column 11), volumes at Imperial Dam.

To assess IID’s ability to meet future water demands, IID historic and forecasted demands are compared with CRWDA Exhibit B net availability, volumes at Imperial Dam Table 11 (Column 11). The analysis requires accounting for system operation consumptive use within the IID water service area, from AAC at Mesa Lateral 5 to Imperial Dam, and for water pumped for use by the USBR Lower Colorado Water Supply Project (LCRWSP), an IID consumptive use component in the USBR Decree Accounting Report. IID system operation consumptive use for 2015 is provided in Table 15 to show the components included in the calculation and their 2015 volumes.

Table 15. IID System Operations Consumptive Use within IID Water Service Area and from AAC at Mesa Lateral 5 to Imperial Dam, (KAF), 2020

	Consumptive Use (KAF)
IID Delivery System Evaporation	24.4
IID Canal Seepage	90.8
IID Main Canal Spill	10.1
IID Lateral Canal Spill	121.5
IID Seepage Interception	-39.0
IID Unaccounted Canal Water	-40.0
Total IID System Operational Use, within water service area	167.8
“Losses” from AAC @ Mesa Lat 5 to Imperial Dam	9.2
LCWSP pumpage	-10
Total System Operational Use in 2020	167.0

Source: 2020 IID Water Balance Rerun 01/25/2021

IID’s ability to meet customer water demands through 2055 as shown in Table 16 is based on the following:

- Non-agricultural use from Table 5.
- Agricultural and Salton Sea mitigation uses from Table 6.
- CRWDA Exhibit B net available for IID consumptive use from Table 11.
- System operation consumptive use from Table 15.

Table 16. IID Historic and Forecasted Consumptive Use vs CRWDA Exhibit B IID Net Available Consumptive Use, volumes at Imperial Dam (KAFY), 2015-2055 Next Update in 2026 thru 2065

	2015	2020	2025	2030	2035	2040	2045	2050	2055
Non-Ag Delivery	110.1	115.2	133.1	142.9	151.4	163.2	175.4	188.4	199.3
Ag Delivery	2,156.8	2,165.4	2,259.5	2,209.5	2,209.5	2,209.5	2,209.5	2,209.5	2,209.5
QSA SS Mitigation Delivery	153.3	0.0	0.0	0.0	0.0	0.0	0.0	0.0	0.0
System Op CU in IID & to Imperial Dam	220.2	167.0	230.5	225.4	225.4	225.4	225.4	225.4	225.4
IID CU at Imperial Dam	2,480.9	2,493.7	2,623.1	2,577.8	2,586.3	2,598.1	2,610.3	2,623.3	2,634.2
Exhibit B IID Net Available for CU at Imperial Dam	2,480.9	2,652.0	2,617.8	2,612.8	2,612.8	2,612.8	2,612.8	2,665.8	2,665.8
IID Underrun/Overrun at Imperial Dam	90.0	-98.1	-5.30	35.00	26.50	14.70	2.50	42.50	31.60

Notes: 2015 Provisional Water Balance rerun 06/28/2019
 Non-Ag Delivery CI 15.0%, Ag Delivery CI 3.0%, QSA SS mitigation CI 15%
 QSA Salton Sea Mitigation Delivery terminates on 12/31/2017
 Underrun /Overrun = IID CU at Imperial Dam minus CRWDA Exhibit B Net Available

Notes: Ag Delivery for 2020-2055 does not take into account land conversion for solar use nor reduction in agricultural land area due to urban expansion.

As shown above, IID forecasted demand has the potential to exceed CRWDA Exhibit B Net Consumptive Use volumes during several time intervals through the lifespan projection for the Project. However, due to temporary land conversion for solar use and urban land expansion that will reduce agricultural acres in the future, a water savings of approximately 217,000 AFY will be generated into the future and for the lifetime of the Project.

In addition, USBR 2020 Decree Accounting Report states that IID Consumptive Use is 2,493.7 KAF (excludes 1,579 AF of ICS storage in Lake Mead and 49,444 AF of conserved water left on the Colorado River system) with an underrun of -98.1 KAF, as reported by IID in 2020 Annual SWRCB Report per WRO 2002-2013; that is, IID uses less than the amount in its approved Water Order (2,615,300 AF).

Table 17. 2020 Approved Water Order, Actual CU (Decree Accounting Report) and IID Underrun, KAF at Imperial Dam

IID Approved Water Order	2,625.3 less 10 supplied by LCWSP and less 26 of additional conserved water
IID Consumptive Use	2,493.7
IID Underrun /Overrun	-98.1

Sources:
 2020 IID Revised Water Order, approved on March 10, 2020, 2019 Decree Accounting Report, and 2020 Annual Report of IID Pursuant to SWRCB Revised Order WRO 2002-2013

As reported in the 2019 QSA Implementation Report and 2020 SWRCB IID Report and presented in Table 17, from 2013 to 2020 IID consumptive use (CU) resulted in underruns; i.e., annual CU was less than the district’s QSA Entitlement of 3.1 MAFY minus QSA/Transfer Agreements obligations. This would indicate that even though Table 16 shows IID Overrun/Underrun at Imperial Dam exceeding CRWDA Exhibit B Net Available for CU, for the 30-year life of the proposed Project, IID consumptive use may be less than forecasted.

Meanwhile, forecasted Ag Delivery reductions presented in **Table 6** are premised on implementation of on-farm practices that will result in efficiency conservation. These reductions do not take into account land conversion for solar projects nor reduction in agricultural land area due to urban expansion; that is to say, the forecasted Ag Delivery is for acreage in 2003 with reduction for projected on-farm conservation efficiency. Thus, Ag Delivery demand may well be less than forecasted in **Table 6**. In any case, the proposed Project will use less water than the historical agricultural demand of proposed Project site, so the proposed Project will ease rather than exacerbate overall IID water demands.

In the event that IID has issued water supply agreements that exhaust the 25 KAFY IWSP set aside, and it becomes apparent that IID delivery demands due to non-agriculture use are going to cause the district to exceed its quantified 3.1 MAFY entitlement less QSA/Transfer Agreements obligations, IID has identified options to meet these new non-agricultural demands. These options include (1) tracking water yield from temporary land conversion from agricultural to non-agricultural land uses (renewable solar energy); and (2) only if necessary, developing projects to expand the size of the district's water supply portfolio.

These factors will be discussed in the next two sections, Tracking Water Savings from Growth of Non-Agricultural Land Uses and Expanding Water Supply Portfolio.

Tracking Water savings from Growth of Non-Agricultural Land Uses

The Imperial County Board of Supervisors has targeted up to 25,000 acres of agricultural lands, about 5 percent (5%) of the farmable acreage served by IID, for temporary conversion to solar farms; because the board found that this level of reduction would not adversely affect agricultural production. As reported for IID's 2020 Temporary Land Conversion Following Program, existing solar developments at the end of 2020 have converted 12,404 acres of farmland. These projects had a yield at-river of 65,964 AF of water in 2020. The balance of the 25,000-acre agriculture-to-solar policy is 12,596 acres. On average, each agricultural acre converted reduces agricultural demand by 5.1 AFY, which results in a total at-river yield (reduction in consumptive use) of 127,500 AFY.

However, due to the nature of the conditional use permits under which solar farms are developed, IID cannot rely on this supply being permanently available. In fact, should a solar project decommission early, that land may go immediately back to agricultural use (it remains zoned an agricultural land). Nevertheless, during their operation, the solar farms do ameliorate pressure on IID to implement projects to meet demand from new non-agricultural projects.

Unlike the impact of solar projects, other non-agricultural uses are projected to grow, as reflected in the nearly 55 percent (55%) increase in non-agricultural water demand from 107.4 KAF in 2015 to 201.4 KAF in 2055 reflected herein in Table 5 This increase in demand of 94 KAFY will more than likely be met by solar development; however, as the land remains zoned as agricultural land, that source is not reliable to be permanently available to IID.

The amount of land developed for residential, commercial, and industrial purposes is projected to grow by 55,733 acres from 2015 to 2050²⁴ within the sphere of influence of the incorporated cities and specific plan areas in Imperial County. A conservative estimate is that such development will displace at least another 24,500 acres of farmland based on the Imperial Local Agency Formation Commission (LAFCO) sphere of influence maps and existing zoning and land use in Imperial County. At 5.13 AFY yield at-river, there would be a 125,000 AFY reduction IID net consumptive use.

The total foreseeable solar project temporary yield at-river (91,800 AFY) and municipal development permanent yield at-river (125,000 AFY) is to reduce forecasted IID net consumptive use at-river 216,800 AFY, which is more than enough to meet the forecast Demand minus Exhibit B Net Available volumes shown in Table 11. This Yield at-river is sufficient to meet the forecasted excess of non-agricultural use over Net Available supply within the IID service area for the next 20 years, as is required for SB 610 analysis.

Farmland retirement associated with municipal development would reduce IID agricultural delivery requirements beyond the efficiency conservation projections shown in **Table 6** and Table 16. Therefore, in the event that [Schedule 7 General Industrial Use](#) water is unavailable, the Applicants will rely on IID IWSP water to supply the Project, as discussed above in the Projected Water Availability section.

Expanding Water Supply Portfolio

While forecasted long-term annual yield-at-river from the reduction in agricultural acreage due to municipal development in the IID service area is sufficient to meet the forecasted excess of non-agricultural use over CRWDA Net Available supply (Table 11) without expanding IID's Water Supply Portfolio, IID has also evaluated the feasibility of a number of capital projects to increase its water supply portfolio.

As reported in [2012 Imperial IRWMP Chapter 12](#), IID contracted with GEI Consultants, Inc. to identify a range of capital project alternatives that the district could implement. Qualitative and quantitative screening criteria and assumptions were developed in consultation with IID staff. Locations within the IID water service area with physical, geographical, and environmental characteristics most suited to implementing short- and long-term alternatives were identified. Technical project evaluation criteria included volumes of water that could be delivered and/or stored by each project, regulatory and permitting complexity, preliminary engineering components, land use requirements, and costs.

After preliminary evaluation, a total of 27 projects were configured:

- 17 groundwater or drain water desalination
- 2 groundwater blending
- 6 recycled water
- 1 groundwater banking

²⁴ IRWMP, Chapter 5, Table 5-14.

- 1 IID system conservation (concrete lining)

Projects were assessed at a reconnaissance level to allow for comparison of project costs. IID staff and the board identified key factors to categorize project alternatives and establish priorities. Lower priority projects were less feasible due to technical, political, or financial constraints. Preferential criteria were features that increased the relative benefits of a project and grant it a higher priority. Four criteria were used to prioritize the IID capital projects:

1. **Financial Feasibility.** Projects whose unit cost was more than \$600/AF were eliminated from further consideration.
2. **Annual Yield.** Project alternatives generating 5,000 AF or less of total annual yield were determined not to be cost-effective and lacking necessary economies of scale.
3. **Groundwater Banking.** Groundwater banking to capture and store underruns is recognized as a beneficial use of Colorado River water. Project alternatives without groundwater banking were given a lower priority.
4. **Partnering.** Project alternatives in which IID was dependent on others (private and/or public agencies) for implementation were considered to have a lower priority in the IID review; this criterion was reserved for the IRWMP process, where partnering is a desirable attribute.

Based on these criteria, the top ten included six desalination, two groundwater blending, one system conservation, and one groundwater storage capital projects. These capital projects are listed in Table 18 which follows.

Table 18. IID Capital Project Alternatives and Cost (May 2009 price levels \$)

Name	Description	Capital Cost	O&M Cost	Equivalent Annual Cost	Unit Cost (\$/AF)	In-Valley Yield (AF)
GW 18	Groundwater Blending E. Mesa Well Field Pumping to AAC	\$39,501,517	\$198,000	\$2,482,000	\$99	25,000
GW 19	Groundwater Blending: E. Mesa Well Field Pumping to AAC w/Percolation Ponds	\$48,605,551	\$243,000	\$3,054,000	\$122	25,000
WB 1	Coachella Valley Groundwater Storage	\$92,200,000	\$7,544,000	\$5,736,746	\$266	50,000
DES 8	E. Brawley Desalination with Well Field and Groundwater Recharge	\$100,991,177	\$6,166,000	\$12,006,000	\$480	25,000
AWC 1	IID System Conservation Projects	\$56,225,000	N/A	\$4,068,000	\$504	8,000
DES 12	East Mesa Desalination with Well Field and Groundwater Recharge	\$112,318,224	\$6,336,000	\$12,831,000	\$513	25,000
DES 4	Keystone Desalination with IID Drain water/ Alamo River	\$147,437,743	\$15,323,901	\$23,849,901	\$477	50,000
DES 14	So. Salton Sea Desalination with Alamo River Water and Industrial Distribution	\$158,619,378	\$15,491,901	\$24,664,901	\$493	50,000
DES 15	So. Salton Sea Desalination with Alamo River Water and MCI Distribution	\$182,975,327	\$15,857,901	\$26,438,901	\$529	50,000

Name	Description	Capital Cost	O&M Cost	Equivalent Annual Cost	Unit Cost (\$/AF)	In-Valley Yield (AF)
DES 2	Keystone Desalination with Well Field and Groundwater Recharge	\$282,399,468	\$13,158,000	\$29,489,000	\$590	50,000

Source: Imperial IRWMP, Chapter 12; see also Imperial IRWMP Appendix N, IID Capital Projects

IID Near Term Water Supply Projections

As mentioned above, IID’s quantified Priority 3(a) water right under the QSA/Transfer Agreements secures 3.1 MAF per year, less transfer obligations of water for IID’s use from the Colorado River, without relying on rainfall in the IID service area. Even with this strong entitlement to water, IID actively promotes on-farm efficiency conservation and is implementing system efficiency conservation measures including seepage recovery from IID canals and the All-American Canal (ACC) and measures to reduce operational discharge. As the IID website [Water Department](#) states:

Through the implementation of extraordinary conservation projects, the development of innovative efficiency measures and the utilization of progressive management tools, the IID Water Department is working to ensure both the long-term viability of agriculture and the continued protection of water resources within its service area.

Overall, agricultural water demand in the Imperial Valley will decrease due to IID system and grower on-farm efficiency conservation measures that are designed to maintain agricultural productivity at pre-QSA levels while producing sufficient yield-at-river to meet IID’s QSA/Transfer Agreements obligations. These efficiencies combined with the conversion of some agricultural land uses to non-agricultural land uses (both solar and municipal), ensure that IID can continue to meet the water delivery demand of its existing and future agricultural and non-agricultural water users, including this Project for the next 20 years and for the life of the proposed Project.

IMPERIAL IRRIGATION DISTRICT FINDINGS

IID serves as the regional wholesale water supplier, importing raw Colorado River water and delivering it, untreated, to agricultural, municipal, industrial, environmental and recreational water users within its Imperial Unit water service area. Imperial County Planning and Development Services serves as the responsible agency with land use authority over the proposed project. Water Assessment findings are summarized as follows:

1. IID's annual entitlement to consumptive use of Colorado River water is capped at 3.1 MAF less water transfer obligations, pursuant to the QSA and Related Agreements. Under the terms of the CRWDA, IID is implementing efficiency conservation measure to reduce net consumptive use of Colorado River water needed to meet its QSA/Transfer Agreements obligations while retaining historical levels of agricultural productivity.
2. In 2020 IID consumptively used 2,493,661 AF of Colorado River water (volume at Imperial Dam); 2,278,598 AF were delivered to customers (including recreational and environmental water deliveries) of which 2,165,386 AF or 95 percent went to agricultural users as per IID's Water Balance run on 1/25/2021.
3. Reduction of IID's net consumptive use of Colorado River water under the terms of the Colorado River Water Delivery Agreement is to be the result of efficiency conservation measures. Agricultural consumptive use in the Imperial Valley will not decline. However, IID operational spill and tailwater will decline, impacting the Salton Sea.
4. Due to the dependability of IID's water rights, Colorado River flows, and Colorado River storage facilities for Colorado River water, it is unlikely that the water supply of IID would be disrupted, even in dry years or under shortage conditions because Mexico, Arizona and Nevada have lower priority and are responsible for reducing their water use during a declared Colorado River water shortage before impacting California.
5. Historically, IID has never been denied the right to use the annual volume of water it has available for its consumptive uses under its entitlement. Nevertheless, IID is participating in discussions for possible actions in response to extreme drought on the Colorado River.
6. The proposed Project has an estimated total water demand of 460 AF or 23 AFY amortized over a 20-year term. Water would typically be pumped from the All-American Canal by water trucks and not delivered through an existing gate. While the initial 18-month construction demand would be 275 AF, the on-going demand over the life of the Project would be 10 AFY. Thus, the proposed Project demand is an increase of 23 AFY from the historical 10-year average.
7. The Project's water use will be covered under the [Schedule 7 General Industrial Use](#). In the event that IID determines that the proposed Project is to utilize IWSP for Non-Agricultural Projects water, the Applicant will enter into an IWSP Water Supply Agreement with IID. In which case, the proposed Project would use 0.1 percent (0.1%) of the 23,800 AYF of IWSP water.

8. Based on the Environmental Impact Report (EIR) prepared for this proposed Project pursuant to the CEQA, California Public Resources Code sections 21000, *et seq.* (SCH No. 2021050018), the Lead Agency hereby finds that the IID projected water supply will be sufficient to satisfy the demands of this proposed Project in addition to existing and planned future uses, including agricultural and non-agricultural uses for a 20-year Water Supply Assessment period and for the 30 -year proposed Project life.
-

ASSESSMENT CONCLUSION

This Water Supply Assessment has determined that IID water supply is adequate for the Vega SES 4, LLC VEGA SES 4 Solar Energy Storage project (proposed Project). The Imperial Irrigation District's IWSP for Non-Agricultural Projects dedicates 25,000 AF of IID's annual water supply to serve new projects. As of January 2021, 23,800 AF per year remain available for new projects ensuring reasonably sufficient supplies for new non-agricultural water users. The project water demand of approximately 23 AFY amortized over 20 years represents 0.1 % of the unallocated supply set aside in the IWSP for non-agricultural project, and approximately 0.01 percent (0.01 %) of forecasted future non-agricultural water demands planned in the Imperial IRWMP through 2055. There has been no prior agricultural water use at the Project site.

For all the reasons described herein, the amount of water available and the stability of the IID water supply along with on-farm and system efficiency conservation and other measures being undertaken by IID and its customers ensure that Vega SES 4, LLC's water needs will be met for the next 20 years as assessed for compliance under SB-610.

RESOURCES AND REFERENCES

1. California Department of Water Resources. (2003). [Guidebook for Implementation of Senate Bill 610 and Senate Bill 221 of 2001](#) to assist water suppliers, cities, and counties in integrating water and land use planning.
2. Imperial County Planning and Development Services. (2008). Imperial County General Plan 2008 Update. El Centro, CA.
3. Imperial Irrigation District. Website: [Equitable Distribution](#).
4. Imperial Irrigation District Website: [Water Conservation Plan](#). (2008). Imperial Irrigation District 2007 Water Conservation Plan. Imperial, CA.
5. Imperial Irrigation District. (2004). IID [Interactive GIS Water Service Area Map](#). Imperial, CA.
6. Imperial Irrigation District. (2009). [Interim Water Supply Policy for Non-Agricultural Projects](#). Imperial, CA
7. Imperial Irrigation District. (2012). [Temporary Land Conversion Following Policy \(TLFCP\) for Water Conservation Yield](#) Water conservation yield attributable to land removed from agricultural production and temporarily fallowed. Updated March 27, 2018.
8. Imperial Irrigation District Water Department. (2013). [Colorado River Water Accounting and Conservation Commitments Update](#). Tina Anderholt Shields, PE. Colorado River Resources Manager Imperial, CA.
9. Imperial Irrigation District. (2017). [2016 QSA Water Conservation & Transfer Agreement Annual Implementation Report](#), Imperial, CA
- 10.
11. Imperial Irrigation District. (2017). Consultation with Anisa J Divine, Ph.D., Senior Planner. Imperial, CA.
12. Imperial Irrigation District. (2017). [Temporary Land Following Conversion Policy. \(TLFCP\)](#).
- 13.
14. Imperial Irrigation District. (2018). [2017 IID SWRCB Report](#).
15. United States Bureau of Reclamation Lower Colorado Region Website: [Boulder Canyon Operations Office – Programs and Activities](#), Lower Colorado River Water Accounting, Water Accounting Reports (1964 - 2015). Compilation of Records in Accordance with Article V of the Decree of the Supreme Court of the United States in Arizona v. California Dated March 9, 1964: Calendar Years 1964 - 2015 Boulder City, NV.

ATTACHMENTS

Attachments

Attachment A: IID Interim Water Supply Policy for Non-Agricultural Projects

(This page intentionally left blank)

PC ORIGINAL PKG

ATTACHMENT A: IID INTERIM WATER SUPPLY POLICY FOR NON-AGRICULTURAL PROJECTS²⁵

1.0 Purpose.

Imperial Irrigation District (the District) is developing an Integrated Water Resources Management Plan (IWRMP) ²⁶ that will identify and recommend potential programs and projects to develop new water supplies and new storage, enhance the reliability of existing supplies, and provide more flexibility for District water department operations, all in order to maintain service levels within the District's existing water service area. The first phase of the IWRMP is scheduled to be completed by the end of 2009 and will identify potential projects, implementation strategies and funding sources. Pending development of the IWRMP, the District is adopting this Interim Water Supply Policy (IWSP) for Non-Agricultural Projects, as defined below, in order to address proposed projects that will rely upon a water supply from the District during the time that the IWRMP is still under development. It is anticipated that this IWSP will be modified and/or superseded to take into consideration policies and data developed by the IWRMP.

2.0 Background.

The IWRMP will enable the District to more effectively manage existing water supplies and to maximize the District's ability to store or create water when the available water supplies exceed the demand for such water. The stored water can be made available for later use when there is a higher water demand. Based upon known pending requests to the District for water supply assessments/verifications and pending applications to the County of Imperial for various Non-Agricultural Projects, the District currently estimates that up to 50,000 acre feet per year (AFY) of water could potentially be requested for Non-Agricultural Projects over the next ten to twenty years. Under the IWRMP the District shall evaluate the projected water demand of such projects and the potential means of supplying that amount of water. This IWSP currently designates up to 25,000 AFY of water for potential Non-Agricultural Projects within IID's water service area. Proposed Non-Agricultural projects may be required to pay a Reservation Fee, further described below. The reserved water shall be available for other users until such Non-Agricultural projects are implemented and require the reserved water supply. This IWSP shall remain in effect pending the approval of further policies that will be adopted in association with the IWRMP.

3.0 Terms and Definitions.

3.1 Agricultural Use. Uses of water for irrigation, crop production and leaching.

²⁵ IID Board Resolution 31-2009. Interim Water Supply Policy for New Non-Agricultural Projects. September 29, 2009. <[IID Interim Water Supply Policy for Non-Agricultural Projects](#)>

²⁶ The 2009 Draft IID IWRMP has been superseded by the October 2012 Imperial IRWMP, which incorporates the conditions of the IWSP by reference.

3.2 Connection Fee. A fee established by the District to physically connect a new Water User to the District water system.

3.3 Industrial Use. Uses of water that are not Agricultural or Municipal, as defined herein, such as manufacturing, mining, cooling water supply, energy generation, hydraulic conveyance, gravel washing, fire protection, oil well re-pressurization and industrial process water.

3.4 Municipal Use. Uses of water for commercial, institutional, community, military, or public water systems, whether in municipalities or in unincorporated areas of Imperial County.

3.5 Mixed Use. Uses of water that involve a combination of Municipal Use and Industrial Use.

3.6 Non-Agricultural Project. Any project which has a water use other than Agricultural Use, as defined herein.

3.7 Processing Fee. A fee charged by the District Water Department to reimburse the District for staff time required to process a request for water supply for a Non-Agricultural Project.

3.8 Reservation Fee. A non-refundable fee charged by the District when an application for water supply for a Non-Agricultural Project is deemed complete and approved. This fee is intended to offset the completion of the application to start-up of construction of the proposed project and/or execution of a water supply agreement. The initial payment of the Reservation Fee will reserve the projected water supply for up to two years. The Reservations Fee is renewable for up to two additional two-year periods upon payment of an additional fee for each renewal.

3.9 Water Supply Development Fee. An annual fee charged to some Non-Agricultural Projects by the District, as further described in Section 5.2 herein. Such fees shall assist in funding IWRMP or related water supply projects,

3.10 Water User. A person or entity that orders or receives water service from the District.

4.0. CEQA Compliance.

4.1 The responsibility for CEQA compliance for new development projects within the unincorporated area of the County of Imperial attaches to the County of Imperial or, if the project is within the boundaries of a municipality, the particular municipality, or if the project is subject to the jurisdiction of another agency, such as the California Energy Commission, the particular agency. The District will coordinate with the County of Imperial, relevant municipality, or other agency to help ensure that the water supply component of their respective general plans is comprehensive and based upon current information. Among other things, the general plans should assess the direct, indirect and cumulative potential impacts on the environment of using currently available water supplies for new industrial, municipal, commercial and/or institutional uses instead of the historical use of that water for agriculture. Such a change in land use, and the associated water use, could potentially impact land uses, various aquatic and terrestrial species, water quality, air quality and the conditions of drains, rivers and the Salton Sea.

4.2 When determining whether to approve a water supply agreement for any Non-Agricultural Project pursuant to this IWSP, the District will consider whether potential environmental and water supply impacts of such proposed projects have been adequately assessed, appropriate mitigation has been developed and appropriate conditions have been adopted by the relevant land use permitting/approving agencies, before the District approves any water supply agreement for such project.

5.0. Applicability of Fees for Non-Agricultural Projects.²⁷

5.1 Pursuant to this Interim Water Supply Policy, applicants for water supply for a Non-Agricultural Project shall be required to pay a Processing Fee and may be required to pay a Reservation Fee as shown in Table A. All Water Users shall also pay the applicable Connection Fee, if necessary, and regular water service fees according to the District water rate schedules, as modified from time to time.

5.2 A Non-Agricultural Project may also be subject to an annual Water Supply Development Fee, depending upon the nature, complexity, and water demands of the proposed project. The District will determine whether a proposed Non-Agricultural Project is subject to the Water Supply Development Fee for water supplied pursuant to this IWSP as follows:

5.2.1. A proposed project that will require water for a Municipal Use shall be subject to an annual Water Supply Development Fee as set forth in Table B if the projected water demand for the project is in excess of the project's estimated population multiplied by the District-wide per capita usage. Municipal Use projects without an appreciable residential component will be analyzed under sub-section 5.2.3.

5.2.2. A proposed project that will require water for an Industrial Use located in an unincorporated area of the County of Imperial shall be subject to an annual Water Supply Development Fee as set forth in Table B.

5.2.3. The applicability of the Water Supply Development Fee set forth in Table B to Mixed Use projects, Industrial Use projects located within a municipality, or Municipal Use projects without an appreciable residential component, will be determined by the District on a case-by-case basis, depending upon the proportion of types of land uses and the water demand proposed for the project.

5.3. A proposed Water User for a Non-Agricultural Projects may elect to provide some or all of the required water supply by paying for and implementing some other means of providing water in a manner approved by the District, such as conservation projects, water storage projects and/or use of an alternative source of supply, such as recycled water or some source of water other than from the District water supply. Such election shall require consultation with the District regarding the details of such alternatives and a determination by the District, in its reasonable discretion, concerning how much credit, if any, should be given for such alternative water supply as against the project's water demand for purposes of determining the annual Water Supply Development Fee for such project.

²⁷ The most recent fee schedules can be found in a link at IID/Water/ Municipal, Industrial and Commercial Customers; or visit by URL at [Imperial Irrigation District : Water Rate Schedules](#)

5.4 The District Board shall have the right to modify the fees shown on Tables A and B from time to time.

6. Water Supply Development Fees collected by the District under this IWSP shall be accounted for independently, including reasonable accrued interest, and such fees shall only be used to help fund IWRMP or related District water supply projects.

7. Any request for water service for a proposed Non-Agricultural Project that meets the criteria for a water supply assessment pursuant to Water Code Sections 10910-10915 or a water supply verification pursuant to Government Code Section 66473.7 shall include all information required by Water Code Sections 10910 –10915 or Government Code Section 66473.7 to enable the District to prepare the water supply assessment or verification. All submittals should include sufficient detail and analysis regarding the project's water demands, including types of land use and per capita water usage, necessary to make the determinations outlined in Section 5.2.

8. Any request for water service for a proposed Non-Agricultural Project that does not meet the criteria for a water supply assessment pursuant to Water Code Section 10910-10915 or water supply verification pursuant to Government Code Section 66473.7 shall include a complete project description with a detailed map or diagram depicting the footprint of the proposed project, the size of the footprint, projected water demand at full implementation of the project and a schedule for implementing water service. All submittals should include sufficient detail and analysis regarding the project's water demands, including types of land use and per capita water usage, necessary to make the determinations outlined in Section 5.2.

9. All other District rules and policies regarding a project applicant or Water User's responsibility for paying connection fees, costs of capital improvements and reimbursing the District for costs of staff and consultant's time, engineering studies and administrative overhead required to process and implement projects remain in effect.

10. Municipal Use customers shall be required to follow appropriate water use efficiency best management practices (BMPs), including, but not limited to those established by the California Urban Water Conservation Council BMP's (see <http://www.cuwcc.org/mou/exhibit-1-bmp-definitions-schedules-requirements.aspx>), or other water use efficiency standards, adopted by the District or local government agencies.

11. Industrial Use customers shall be required to follow appropriate water use efficiency BMP's, including but not limited to those established by the California Urban Water Conservation Council and California Energy Commission, as well as other water use efficiency standards, adopted by the District or local government agencies.

12. The District may prescribe additional or different BMPs for certain categories of Municipal and Industrial Water Users.

(This page intentionally left blank)

Energy Impact Assessment

Vega SES 4 Solar Energy Storage Project

County of Imperial, California

Prepared For:

Vega SES 4, LLC
604 Sutter Street
Suite 250
Folsom, California 95630

February 2021



ECORP Consulting, Inc.
ENVIRONMENTAL CONSULTANTS

PC ORIGINAL PKG

CONTENTS

1.0 INTRODUCTION 1

 1.1 Project Overview..... 1

 1.2 Project Location 1

 1.3 Applicable Land Use Regulations 1

 1.4 Project Site Access..... 2

 1.5 Project Construction 2

2.0 Energy Consumption..... 4

 2.1 Energy Types and Sources..... 4

 2.1.1 Energy Consumption 4

 2.2 Regulatory Framework..... 5

 2.2.1 State..... 5

 Renewable Energy Sources (Renewable Portfolio Standards) 6

 2.3 Energy Consumption Impact Assessment..... 6

 2.3.1 Thresholds of Significance 6

 2.3.2 Methodologie 7

 2.3.3 Impact Analysis..... 7

 2.4 Energy Consumption 7

3.0 REFERENCES..... 10

LIST OF TABLES

Table 2-1. Electricity Consumption in Imperial County 2015-2019..... 4

Table 2-2. Natural Gas Consumption in Imperial County 2015-2019 5

Table 2-3. Automotive Fuel Consumption in Imperial County 2016-2020..... 5

Table 2-4. Proposed Project Energy and Fuel Consumption 8

LIST OF FIGURES

Figure 1. Project Location and Vicinity..... 3

ATTACHMENTS

Attachment A - Energy Consumption Modeling Output

LIST OF ACRONYMS AND ABBREVIATIONS

APNs	Assessor's Parcel Numbers
CalEEMod	California Emissions Estimator Model
CAISO	California Independent System Operator
CARB	California Air Resources Board
CEC	California Energy Commission
CPUC	California Public Utility Commission
EPS	Emissions Performance Standard
HSAT	Horizontal Single-Axis Tracker
IID	Imperial Irrigation District
kWh	Kilowatt-Hours
MW	Megawatt
mWh	Megawatt Hour
PV	Photovoltaic
Project	Vega SES 4 Solar Energy Storage Project
RPS	Renewables Portfolio Standard

1.0 INTRODUCTION

This report documents the results of an Energy Impact Assessment completed for the Vega SES 4 Solar Energy Storage Project (Project), which includes the construction of a nominal 100-megawatt (MW) alternating current solar photovoltaic (PV) energy generation system with an integrated 100 MW battery storage project on approximately 531.53 acres of land in Imperial County, California. This report was prepared to analyze the potential direct and indirect environmental impacts associated with Project energy consumption, including the depletion of nonrenewable resources (oil, natural gas, coal, etc.) during the construction and operational phases. The impact analysis focuses on the four sources of energy that are relevant to the proposed Project: electricity, natural gas, the equipment-fuel necessary for Project construction, and the automotive fuel necessary for Project operations.

1.1 Project Overview

The Project proposes to construct a nominal 100 MW alternative current PV energy generation system, accompanied by a 100 MW battery storage, utilizing either thin film or crystalline solar PV technology modules mounted either on fixed frames or horizontal single-axis tracker (HSAT) systems. The fixed frame PV module arrays would be mounted on racks that would be supported by driven piles. The individual PV systems would be arranged in large arrays by placing them in columns spaced approximately ten feet apart to maximize operational performance and to allow access for panel cleaning and maintenance.

1.2 Project Location

The Project site is an approximately 531.53-acre site located between the California/Mexico border and the All-American Canal (Aqueduct), on the California side in southcentral Imperial County (County) (see Figure 1). The Project site is located approximately 1.92 miles southeast of the Bonds Corner Road/East Cedar Street/California State Route 98 intersection near the unincorporated community of Bonds Corner. The Project would be located on Imperial County Assessor's Parcel Numbers (APNs) 059-300-015-000 (approximately 301.73 acres), 059-300-017-000 (approximately 148.88 acres) and 059-290-010-000 (approximately 80.92 acres). The irregular shaped site is bound by undeveloped agricultural land to the south, west and east, and the Aqueduct running southwest on the northern border of the proposed Project site. The Project site is currently characterized by flat and undeveloped agricultural land.

1.3 Applicable Land Use Regulations

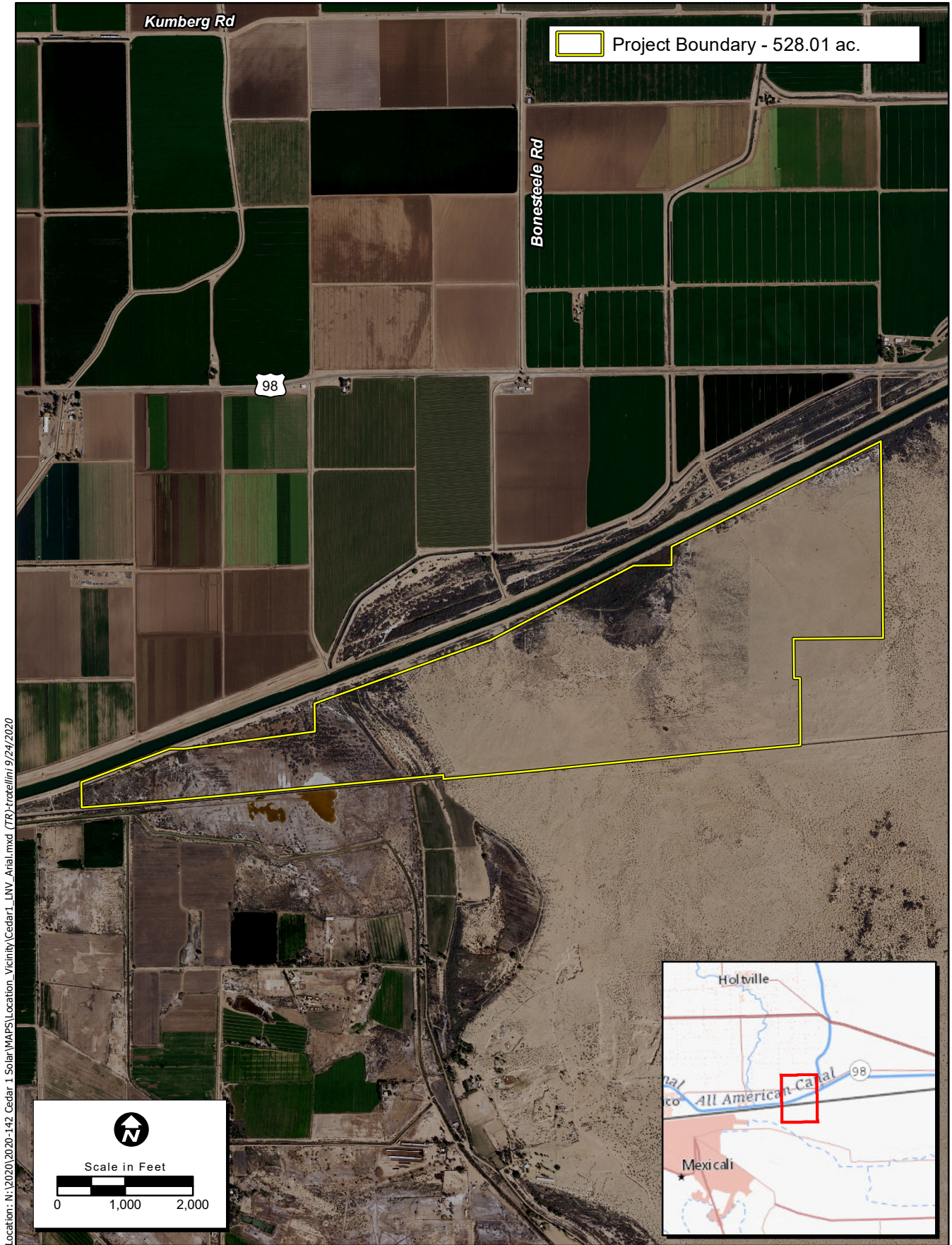
All three of the Project area parcels are designated as "Agriculture" in the Imperial County General Plan and are zoned A-3-RE (Heavy Agriculture with a Renewable Energy Overlay-areas that are suitable for agricultural land uses; to prevent the encroachment of incompatible uses onto and within agricultural lands; and to prohibit the premature conversion of such lands to non-agricultural uses). Pursuant to Section 91703.02 (*Conditional Use Permits*), Renewable Energy Projects must be located within the Renewable Energy Overlay Zone and may be permitted only through the issuance of a Conditional Use Permit (CUP) as approved by the Approving Authority unless otherwise allowed by applicable law. At present, the Project is located within the Renewable Energy Zone.

1.4 Project Site Access

The Project site would include one primary access driveway, currently contemplated across the East Highline Check of the Aqueduct, in the far northeastern corner of the Project area and a secondary access driveway (if required) with a to-be-determined location. This driveway would be provided with a minimum of 30-foot double swing gates with "Knox Box" for keyed entry. Internal to the Project site up to 30-foot wide roads would be provided between the PV arrays, as well as around the perimeter of each Project site inside the perimeter security fence to provide access to all areas of each site for maintenance and emergency vehicles.

1.5 Project Construction

Construction activities would primarily involve demolition and grubbing; grading of the Project area to establish access roads and pads for electrical equipment (inverters and step-up transformers); trenching for underground electrical collection lines; and the installation of solar equipment and security fencing. The construction of the site is estimated to take 12-18 months and would begin in 2022. A temporary, portable construction supply container would be located at the Project site at the beginning of construction and removed at the end of construction. The number of on-site construction workers for the solar project facilities is not expected to exceed 150 workers at any one time. The number of on-site construction workers for the battery storage facility and the substation is not expected to exceed 100 workers at any one time. Onsite parking would be provided for all construction workers.



Location: N:\2020\2020-142_Cedar_1_Solar\WAPS\Location_Vicinity\Cedar1_LINV_Arial.mxd (TR)-truelin\9/24/2020

Map Date: 9/24/2020
 Service Layer Credits:
 Photo Source: NAIP (2018)

Figure 1. Project Location and Vicinity

2020-142 Vega SES 4

2.0 ENERGY CONSUMPTION

2.1 Energy Types and Sources

California relies on a regional power system comprised of a diverse mix of natural gas, renewable, hydroelectric, and nuclear generation resources. Natural gas provides California with a majority of its electricity followed by renewables, large hydroelectric and nuclear (California Energy Commissions [CEC] 2020). Imperial Irrigation District (IID), the sixth largest electrical utility in California serving more than 150,000 customers in the Imperial Valley and parts of Riverside and San Diego counties, provides electrical services to the Project area. IID controls more than 1,100 megawatts of energy derived from a diverse resource portfolio that includes its own generation, and long- and short-term power purchases. Located in a region with abundant sunshine, enviable geothermal capacity, wind and other renewable potential, IID has met or exceeded all Renewable Portfolio Standard requirements to date, procuring renewable energy from diverse sources, including biomass, biowaste, geothermal, hydroelectric, solar and wind.

The Southern California Gas Company provides natural gas services to Imperial County. As the nation's largest natural gas distribution utility, the Southern California Gas Company delivers natural gas energy to 21.6 million consumers through 5.9 million meters in more than 500 communities. The Southern California Gas Company's service territory encompasses approximately 20,000 square miles throughout Central and Southern California, from Visalia to the Mexican border.

2.1.1 Energy Consumption

Electricity use is measured in kilowatt-hours (kWh), and natural gas use is measured in therms. Vehicle fuel use is typically measured in gallons (e.g. of gasoline or diesel fuel), although energy use for electric vehicles is measured in kWh.

The electricity consumption associated with all uses in Imperial County from 2015 to 2019 is shown in Table 2-1. As indicated, the demand has remained constant since 2015.

Table 2-1. Electricity Consumption in Imperial County 2015-2019	
Year	Electricity Consumption (kilowatt hours)
2019	1,415,790,908
2018	1,467,590,638
2017	1,445,167,336
2016	1,440,493,016
2015	1,419,088,130

Source: CEC 2019

The natural gas consumption associated with all uses in Imperial County from 2015 to 2019 is shown in Table 2-2. As indicated, the demand has increased since 2015.

Table 2-2. Natural Gas Consumption in Imperial County 2015-2019	
Year	Natural Gas Consumption (therms)
2019	42,914,053
2018	38,729,625
2017	40,442,318
2016	36,089,854
2015	31,494,256

Source: CEC 2019

Automotive fuel consumption in Imperial County from 2016 to 2020 is shown in Table 2-3. Fuel consumption has decreased between 2016 and 2020.

Table 2-3. Automotive Fuel Consumption in Imperial County 2016-2020	
Year	Total Fuel Consumption (gallons)
2020	196,177,597
2019	198,822,094
2018	201,793,138
2017	204,312,157
2016	208,822,214

Source: California Air Resources Board (CARB) 2017

2.2 Regulatory Framework

2.2.1 State

Executive Order B-55-18

In September 2018 Governor Jerry Brown Signed Executive Order (EO) B-55-18, which establishing a new statewide goal “to achieve carbon neutrality as soon as possible, and no later than 2045, and achieve and maintain net negative emissions thereafter.” Carbon neutrality refers to achieving a net zero carbon dioxide emissions. This can be achieved by reducing or eliminating carbon emissions, balancing carbon emissions with carbon removal, or a combination of the two. This goal is in addition to existing statewide targets for GHG emission reduction. EO B-55-18 requires the California Air Resource Board (CARB) to “work with relevant state agencies to ensure future Scoping Plans identify and recommend measures to achieve the carbon neutrality goal.

Senate Bill 1368

On September 29, 2006, Governor Arnold Schwarzenegger signed into law Senate Bill (SB) 1368 (Perata, Chapter 598, Statutes of 2006). The law limits long-term investments in baseload generation by the state's utilities to those power plants that meet an emissions performance standard jointly established by the CEC and the California Public Utilities Commission (CPUC).

The CEC has designed regulations that:

- Establish a standard for baseload generation owned by, or under long-term contract to, publicly owned utilities, of 1,100 pounds carbon dioxide per megawatt hour (mWh). This would encourage the development of power plants that meet California's growing energy needs while minimizing their emissions of greenhouse gas.
- Require posting of notices of public deliberations by publicly owned utilities on long-term investments on the CEC website. This would facilitate public awareness of utility efforts to meet customer needs for energy over the long term while meeting the State's standards for environmental impact.
- Establish a public process for determining the compliance of proposed investments with the emissions performance standard (EPS) (Perata, Chapter 598, Statutes of 2006).

Renewable Energy Sources (Renewable Portfolio Standards)

Established in 2002 under SB 1078, and accelerated by SB 107 (2006) and SB 2 (2011), California's Renewables Portfolio Standard (RPS) obligates investor-owned utilities, energy service providers, and community choice aggregators to procure 33 percent of their electricity from renewable energy sources by 2020. Eligible renewable resources are defined in the 2013 RPS to include biodiesel; biomass; hydroelectric and small hydro (30 megawatts or less); Los Angeles Aqueduct hydro power plants; digester gas; fuel cells; geothermal; landfill gas; municipal solid waste; ocean thermal, ocean wave, and tidal current technologies; renewable derived biogas; multi-fuel facilities using renewable fuels; solar photovoltaic; solar thermal electric; wind; and other renewables that may be defined later. Governor Jerry Brown signed SB 350 on October 7, 2015, which expands the RPS by establishing a goal of 60 percent of the total electricity sold to retail customers in California per year by December 31, 2030. In addition, SB 350 includes the goal to double the energy efficiency savings in electricity and natural gas final end uses (such as heating, cooling, lighting, or class of energy uses upon which an energy efficiency program is focused) of retail customers through energy conservation and efficiency. The bill also requires the CPUC, in consultation with the CEC, establish efficiency targets for electrical and gas corporations consistent with this goal. SB 350 also provides for the transformation of the California Independent System Operator (CAISO) into a regional organization to promote the development of regional electricity transmission markets in the western states and to improve the access of consumers served by the CAISO to those markets, pursuant to a specified process. In 2018, SB 100 was signed by Governor Brown, codifying a goal of 60 percent renewable procurement by 2030 and 100 percent by 2045 Renewables Portfolio Standard.

2.3 Energy Consumption Impact Assessment

2.3.1 Thresholds of Significance

The impact analysis provided below is based on the following CEQA Guidelines Appendix G thresholds of significance. The Project would result in a significant impact to energy if it would do any of the following:

- 1) Result in potentially significant environmental impact due to wasteful, inefficient, or unnecessary consumption of energy resources, during project construction or operation.

- 2) Conflict with or obstruct a state or local plan for renewable energy or energy efficiency.

The impact analysis focuses on the four sources of energy that are relevant to the proposed Project: electricity, natural gas, the equipment fuel necessary for Project construction, and the automotive fuel necessary for Project operations. Addressing energy impacts requires an agency to make a determination as to what constitutes a significant impact. There are no established thresholds of significance, statewide or locally, for what constitutes a wasteful, inefficient, and unnecessary consumption of energy for a proposed land use. For the purposes of this analysis, the amount of electricity and natural gas estimated to be consumed by the Project are quantified and compared to that consumed by all land uses in Imperial County. Similarly, the amount of fuel necessary for Project construction and operations is calculated and compared to that consumed in Imperial County.

2.3.2 Methodology

Levels of construction and operational related energy consumption estimated to be consumed by the Project include the number of kWh of electricity, therms of natural gas and gallons of gasoline. Modeling was based on Project specific information such as construction timing and equipment as well as site operations. Energy consumption estimates were calculated using the California Emissions Estimator Model (CalEEMod), version 2016.3.2. CalEEMod is a statewide land use computer model designed to quantify resources associated with both construction and operations from a variety of land use projects.

2.3.3 Impact Analysis

2.4 Energy Consumption

The Project is proposing the development of a 100 MW alternating current PV energy generation system with an integrated 100 MW battery on approximately 531.53 acres of land. Operations of the proposed Project would not result in the consumption of electricity or natural gas and thus, would not contribute to the County wide usage and would directly support the RPS goal of increasing the percentage of electricity procured from renewable sources.

Therefore, this impact analysis focuses on the two sources of energy that are most relevant to the Project: the equipment fuel necessary for construction and the automotive fuel necessary for ongoing maintenance activities. The amount of total construction-related fuel use was estimated using ratios provided in the Climate Registry's General Reporting Protocol for the Voluntary Reporting Program, Version 2.1. The amount of operational fuel use was estimated using CARB's EMFAC2017 computer program, which provides projections for typical daily fuel usage in Imperial County. This analysis conservatively assumes that all of the automobile trips projected to arrive at the Project during operations would be new to Imperial County.

Energy consumption associated with the proposed Project is summarized in Table 2-4. Project increases in automotive fuel consumption are compared with the countywide fuel consumption in 2020, the most recent full year of data.

Table 2-4. Proposed Project Energy and Fuel Consumption		
Energy Type	Annual Energy Consumption	Percentage Increase Countywide
Electricity Consumption ¹	0 kilowatt-hours	0.00000 percent
Natural Gas ¹	0 therms	0.00000 percent
<i>Automotive Fuel Consumption</i>		
Project Construction 2022 ²	77,931 gallons	0.03971 percent
Project Construction 2023 ²	45,123 gallons	0.02299 percent
Project Operations ³	128 gallons	0.00006 percent

Source: ¹CalEEMod; ²Climate Registry 2016; ³EMFAC2017 (CARB 2017)

Notes: The Project increases in electricity and natural gas consumption are compared with all uses in Imperial County in 2019, the latest data available. The Project increases in automotive fuel consumption are compared with the countywide fuel consumption in 2020, the most recent full year of data.

Fuel necessary for Project construction would be required for the operation and maintenance of construction equipment and the transportation of materials to the Project site. The fuel expenditure necessary to construct the solar facility and infrastructure would be temporary, lasting only as long as Project construction. As indicated in Table 2-4, the Project’s gasoline fuel consumption during the one-time construction period is estimated to be 77,931 gallons during 2022 construction and 45,123 gallons during 2023 construction. This would increase the annual countywide gasoline fuel use in the county by 0.03971 percent and 0.02299 percent respectively. As such, Project construction would have a nominal effect on local and regional energy supplies. No unusual Project characteristics would necessitate the use of construction equipment that would be less energy efficient than at comparable construction sites in the region or the state. Construction contractors would purchase their own gasoline and diesel fuel from local suppliers and would judiciously use fuel supplies to minimize costs due to waste and subsequently maximize profits. Additionally, construction equipment fleet turnover and increasingly stringent state and federal regulations on engine efficiency combined with state regulations limiting engine idling times and requiring recycling of construction debris, would further reduce the amount of transportation fuel demand during Project construction. For these reasons, it is expected that construction fuel consumption associated with the Project would not be any more inefficient, wasteful, or unnecessary than other similar development projects of this nature.

Once construction is completed the Project would be remotely controlled. No employees would be based at the Project site. The only operational emissions associated with the Project would be associated with motor vehicle use for routine maintenance work and site security as well as panel upkeep and cleaning. A conservative estimate of one vehicle trip per day generated by the Project was assumed. This is a conservative estimate as most days would require no operational related vehicle trips. As indicated in Table 2-4, this would estimate to a consumption of approximately 128 gallons of automotive fuel per year, which would increase the annual countywide automotive fuel consumption by 0.00006 percent. Fuel consumption associated with both the construction equipment needed to construction the Project and the vehicle trips generated by the Project during ongoing maintenance activities would not be considered inefficient, wasteful, or unnecessary in comparison to other similar developments in the region.

State and Local Plans for Renewable Energy/Energy Efficiency

The purpose of the proposed Project is the construction of a renewable energy and storage facility in Imperial County. Once in operation, it will decrease the need for energy from fossil fuel-based power plants in the state. The result would be a net increase in electricity resources available to the regional grid, generated from a renewable source. Therefore, the Project would directly support the RPS goal of increasing the percentage of electricity procured from renewable sources. Additionally, the Project would also be consistent with the County's General Plan Conservation and Open Space Element, Objective 9.2 which encourages renewable energy developments. Therefore, the Project would directly support state and local plans for renewable energy development.

3.0 REFERENCES

CARB. 2017. EMFAC2017 Web Database Emissions Inventory. <https://www.arb.ca.gov/emfac/2017/>.

CEC. 2020. 2019 Total System Electric Generations in Gigawatt Hours.

<https://www.energy.ca.gov/data-reports/energy-almanac/california-electricity-data/2019-total-system-electric-generation>

_____. 2019. California Energy Consumption Database. <http://www.ecdms.energy.ca.gov/Default.aspx>.

Climate Registry. 2016. *General Reporting Protocol for the Voluntary Reporting Program version 2.1*.

January 2016. <http://www.theclimateregistry.org/wp-content/uploads/2014/11/General-Reporting-Protocol-Version-2.1.pdf>

LIST OF ATTACHMENTS

Attachment A - Energy Consumption Modeling Output

Action	Carbon Dioxide Equivalents (CO ₂ e) in Metric Tons ¹	Conversion of Metric Tons to Kilograms ²	Construction Equipment Emission Factor ²	Total Gallons of Fuel Consumed
Project Construction	791	791000	10.15	77,931
		Per Climate Registry Equation 13e	Per Climate Registry Equation 13e	
	Per CalEEMod Output Files.			

Total Gallons Consumed During 2022 Project Construction:

77,931

Notes:

Fuel used by all construction equipment, including vehicle hauling trucks, assumed to be diesel.

Sources:

¹ECORP Consulting, 2021.

²Climate Registry. 2016. *General Reporting Protocol for the Voluntary Reporting Program version 2.1*. January 2016.
<http://www.theclimateregistry.org/wp-content/uploads/2014/11/General-Reporting-Protocol-Version-2.1.pdf>

**Proposed Project
Total Construction-Related
and Operational
Gasoline Usage**

Action	Carbon Dioxide Equivalents (CO₂e) in Metric Tons¹	Conversion of Metric Tons to Kilograms²	Construction Equipment Emission Factor²	Total Gallons of Fuel Consumed
Project Construction	458	458000	10.15	45,123
		<small>Per Climate Registry Equation 13e</small>	<small>Per Climate Registry Equation 13e</small>	
	<small>Per CalEEMod Output Files.</small>			

Total Gallons Consumed During 2023 Project Construction: 45,123

Notes:
Fuel used by all construction equipment, including vehicle hauling trucks, assumed to be diesel.

Sources:
¹ECORP Consulting, 2021.

²Climate Registry. 2016. *General Reporting Protocol for the Voluntary Reporting Program version 2.1*. January 2016.
<http://www.theclimateregistry.org/wp-content/uploads/2014/11/General-Reporting-Protocol-Version-2.1.pdf>

Total Gallons During Project Operations³

Area	Sub-Area	Cal. Year	Season	Veh_tech	EMFAC 2011 Category	Fuel_GAS Output	Daily Total	ANNUAL TOTAL
Sub-Areas	Imperial	2023	Annual	All Vehicles	All Vehicles ⁴	0.000350094	0.350093775	127.8

Sources:
³Californai Air Resource Board. 2017. EMFAC2017 Mobile Emissions Model.

Notes:
⁴Excluding Heavy-Duty Highway Trucks, T6 Agricultural Truck, T6 Instate Construction (heavy and small), T7 Agricultural Truck, T7 CAIRP Construction, T7 Single Construction, T7 Tractor Truck, and T7 Tractor Construction